

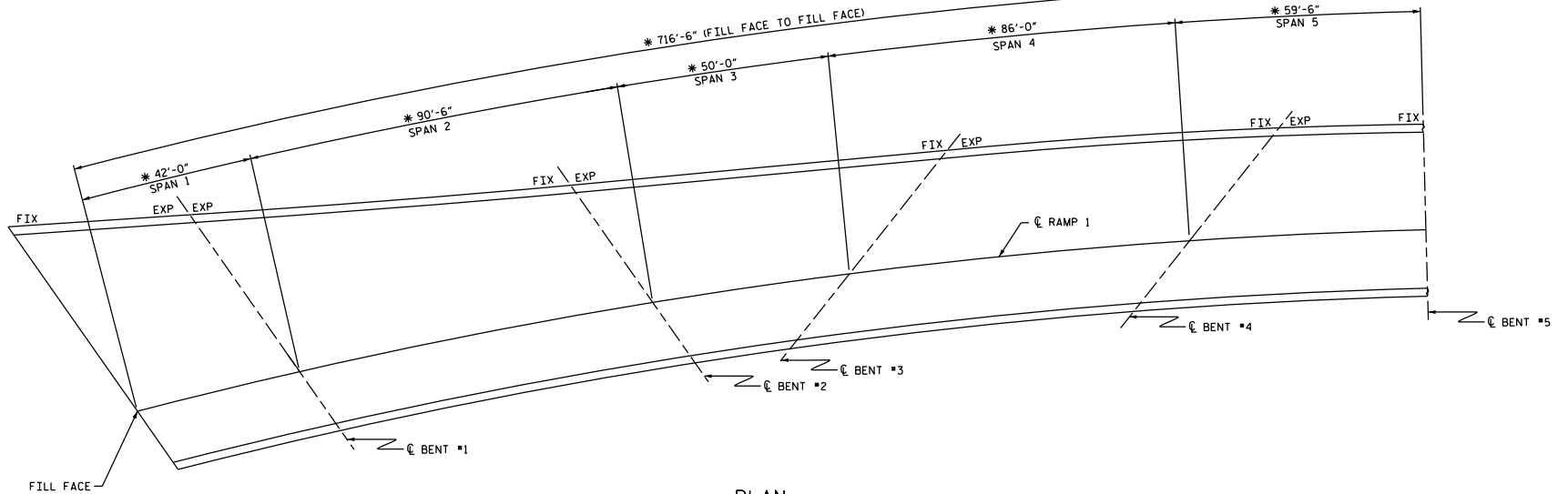

← TO 5TH ST.



PLAN  
\* RADIAL

- APPROX. AREA: CLASS II REPAIR
- APPROX. AREA: CLASS III REPAIR

**NOTES**

FOR OVERLAY OF BRIDGE WITH LATEX MODIFIED CONCRETE- VERY EARLY STRENGTH, SEE SPECIAL PROVISIONS.  
 FOR HYDRO-DEMOLITION AND DECK SCARIFICATION, SEE SPECIAL PROVISIONS.  
 THE CONTRACTOR MUST COLLECT, TREAT AND DISPOSE OF RUN-OFF WATER FROM THE HYDRO-DEMOLITION PROCESS, SEE SPECIAL PROVISIONS.  
 THE BOUNDARIES OF AREAS IDENTIFIED FOR CLASS III SURFACE PREPARATION ARE APPROXIMATE.  
 FOR FOAM JOINT SEALS, SEE SPECIAL PROVISIONS.  
 FOR ELASTOMERIC CONCRETE, SEE SPECIAL PROVISIONS.  
 EXISTING JOINTS AND DECK DRAINS SHALL BE SEALED PRIOR TO BEGINNING REPAIR OF BRIDGE DECK WITH LATEX MODIFIED CONCRETE, SEE SPECIAL PROVISIONS.  
 EXISTING DIMENSIONS AND BRIDGE CONDITIONS ARE FROM THE BEST INFORMATION AVAILABLE. THE CONTRACTOR SHALL FIELD VERIFY THE INFORMATION IN THE PLANS AND NOTIFY THE ENGINEER IF PLAN DIMENSIONS DIFFER FROM ACTUAL CONDITIONS IN THE FIELD.

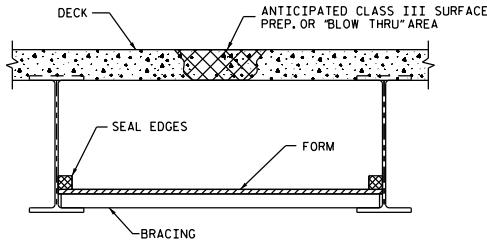

**TYP. "BLOW THRU" CONTAINMENT AND FORMWORK**

A METHOD TO CAPTURE WATER AND DEBRIS FROM BLOW THRU DURING HYDRO-DEMOLITION SHALL BE INSTALLED IN AREAS INDICATED AS CLASS III SURFACE PREPARATION.  
 SUBMIT DETAILS OF PROPOSED FORM WORK FOR APPROVAL PRIOR TO BEGINNING WORK.  
 COST FOR INSTALLING AND REMOVING FORM WORK SHALL BE INCIDENTAL TO THE PRICE PER SQ. YARD OF HYDRO-DEMOLITION.

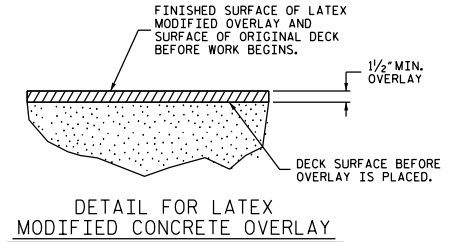

TOTAL BILL OF MATERIAL								
SCARIFYING BRIDGE DECK	** CLASS I SURFACE PREPARATION	** CLASS II SURFACE PREPARATION	** CLASS III SURFACE PREPARATION	HYDRO-DEMOLITION OF BRIDGE DECK	LATEX MODIFIED CONCRETE VERY EARLY STRENGTH	PLACING & FINISHING LATEX MODIFIED CONCRETE VERY EARLY STRENGTH	FOAM JOINT SEALS	GROOVING BRIDGE FLOOR
SO.YDS.	SO.YDS.	SO.YDS.	SO.YDS.	SO.YDS.	C.Y.	SO.YDS.	LUMP SUM	SO. FT.
3322	0	0	0	3322	162	3322	LUMP SUM	27168

\*\* QUANTITY SHOWN IS FOR INFORMATION ONLY.

PROJECT NO. BP-5300M  
 COUNTY: MECKLENBURG  
 DECK REPAIR BRIDGE NO. 309

STATE OF NORTH CAROLINA  
 DEPARTMENT OF TRANSPORTATION  
 RALEIGH

PLAN VIEW OF  
 BRIDGE #309 RAMP ON  
 US 74 WBL OVER NC 27

REVISIONS						SHEET NO.
NO.	BY	DATE	NO.	BY	DATE	SHEET NO.
1			3			S-1
2			4			TOTAL SHEETS 3

DRAWN BY: CLB DATE: 11/11  
 CHECKED BY: DCM DATE: 12/11

\*\*\*\*\*SYTIME\*\*\*\*\*

TO CENTRAL AVE. →

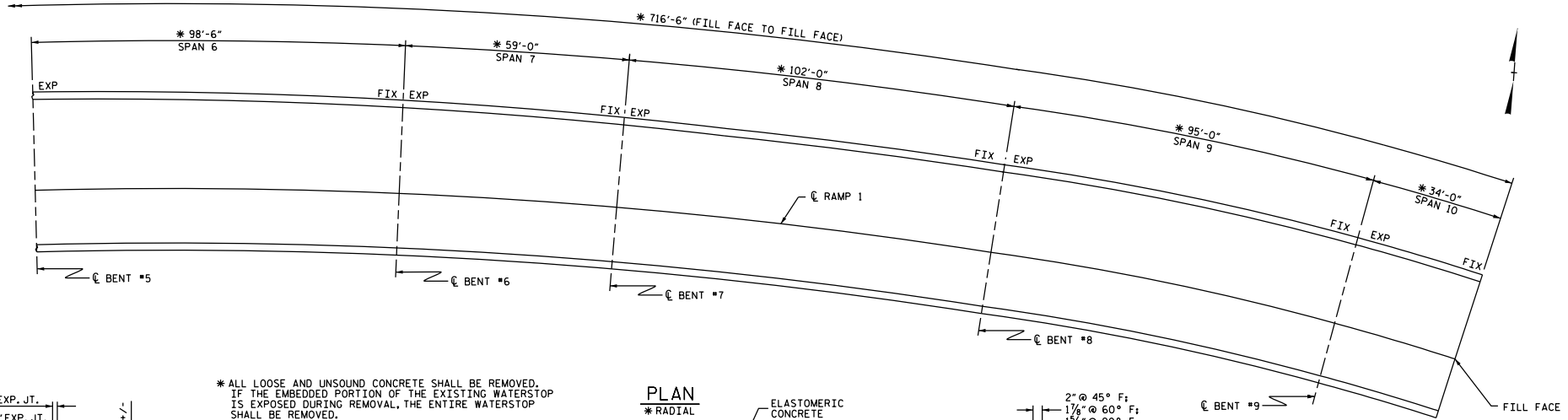

\* ALL LOOSE AND UNSOUND CONCRETE SHALL BE REMOVED. IF THE EMBEDDED PORTION OF THE EXISTING WATERSTOP IS EXPOSED DURING REMOVAL, THE ENTIRE WATERSTOP SHALL BE REMOVED.

**PLAN**  
\* RADIAL

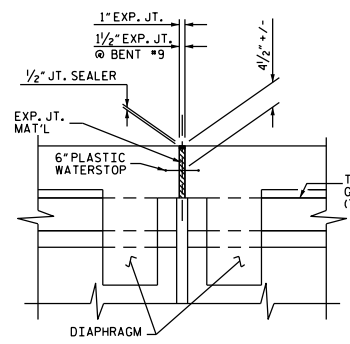

**SECTION A-A**  
(EXISTING JOINT)

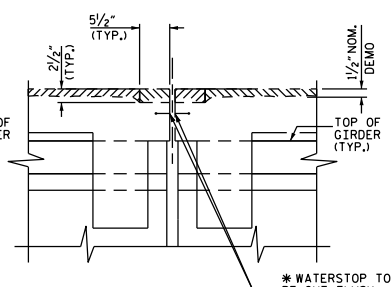

**SECTION A-A**  
(MINIMUM EXISTING JOINT DEMOLITION)

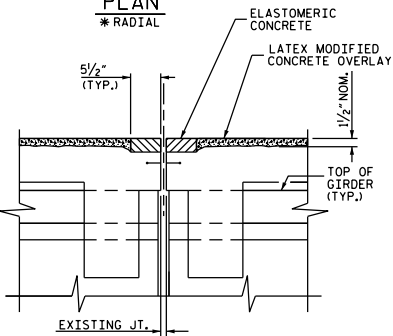

**SECTION A-A**  
(FOAM JOINT SEAL (PRE-SAWED ELASTOMERIC CONCRETE DIMENSIONS))

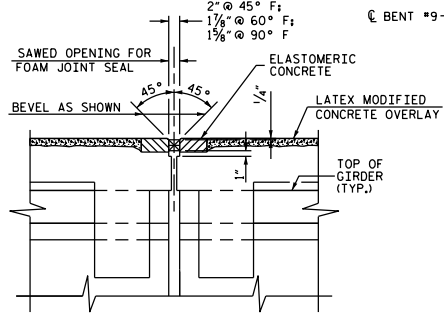

**SECTION A-A**  
(FOAM JOINT SEAL EXPANSION)

**NOTES**  
FOR FOAM JOINT SEAL, SEE SPECIAL PROVISIONS.  
THE INSTALLED FOAM JOINT SEALS SHALL BE WATERTIGHT.  
NOMINAL UNCOMPRESSED SEAL WIDTH OF FOAM JOINT SEAL SHALL BE 2 1/2".  
THE CONTRACTOR WILL NOT BE PERMITTED TO FORM THE JOINT FOR THE FOAM JOINT SEAL IN LIEU OF SAWING THE JOINT.

ELASTOMERIC CONCRETE	
BENTS	165.4 (CU. FT.)
<b>* TOTAL</b>	<b>165.4 (CU. FT.)</b>

\* BASED ON THE MINIMUM BLOCKOUT SHOWN.

NOTE: RETAIN ALL EXISTING REINFORCING STEEL. CLEAN AND REPAIR AS REQ'D.

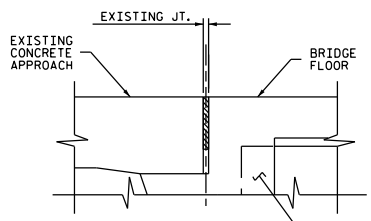

**SECTION B-B**  
(EXISTING JOINT)

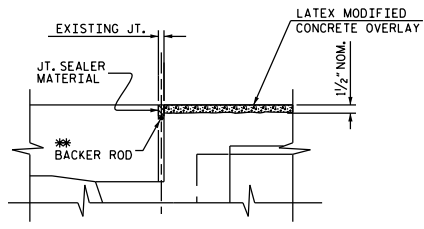

**SECTION B-B**  
(PROPOSED JOINT)

\* BACKER ROD DIA. TO BE DETERMINED BY THE ENGINEER.

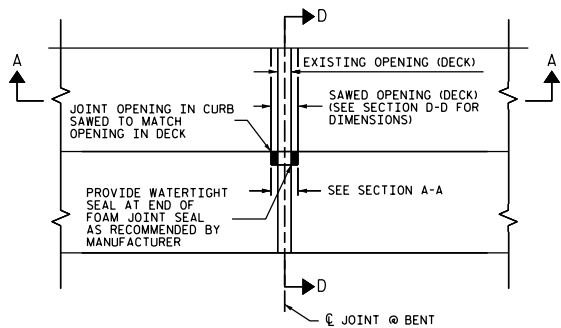

**PLAN**

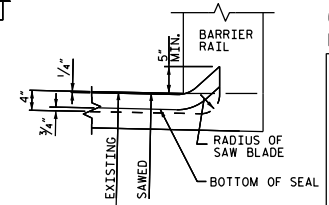

**SECTION D-D**

PROJECT NO. BP-5300M  
COUNTY: MECKLENBURG  
DECK REPAIR BRIDGE NO. 309

STATE OF NORTH CAROLINA  
DEPARTMENT OF TRANSPORTATION  
RALEIGH

TYPICAL SECTIONS  
&  
JOINT DETAILS

REVISIONS						SHEET NO. S-2
NO.	BY	DATE	NO.	BY	DATE	
1			3			TOTAL SHEETS 3
2			4			

DRAWN BY: CLB DATE: 11/11  
CHECKED BY: DCM DATE: 12/11

\*\*\*\*\*SERIAL\*\*\*\*\* \*\*\*\*\*SYSTEM\*\*\*\*\*

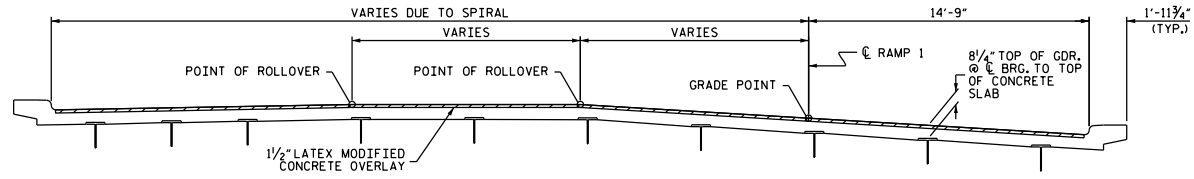

TYPICAL SECTION  
SPAN 1

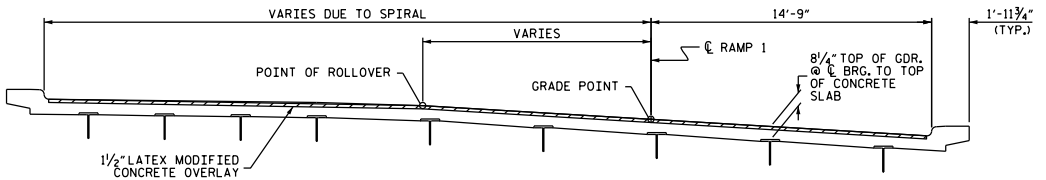

TYPICAL SECTION  
SPAN 2

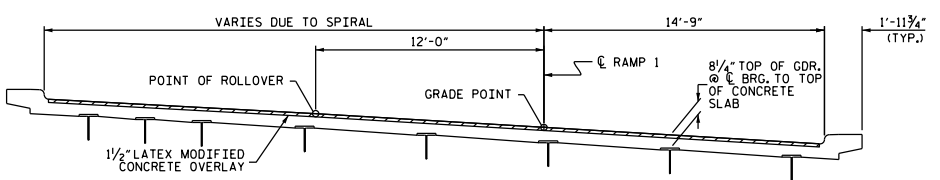

TYPICAL SECTION  
SPAN 3

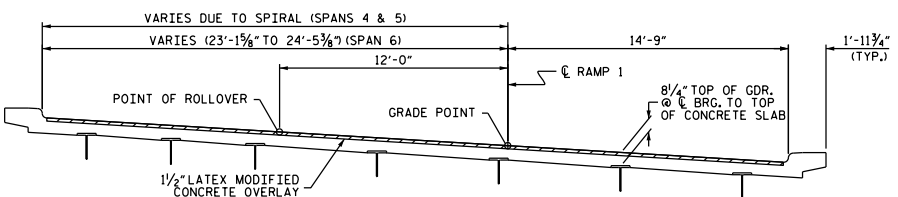

TYPICAL SECTION  
SPANS 4,5&6

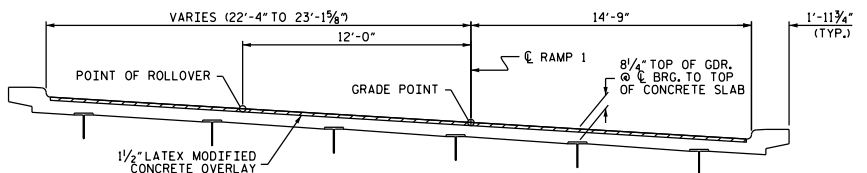

TYPICAL SECTION  
SPAN 7

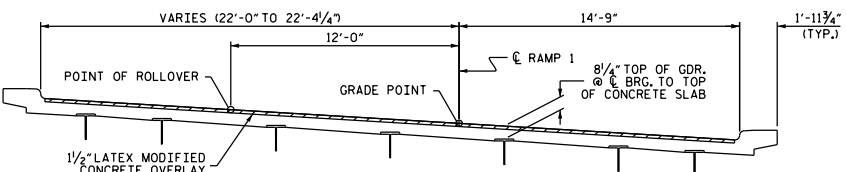

TYPICAL SECTION  
SPAN 8

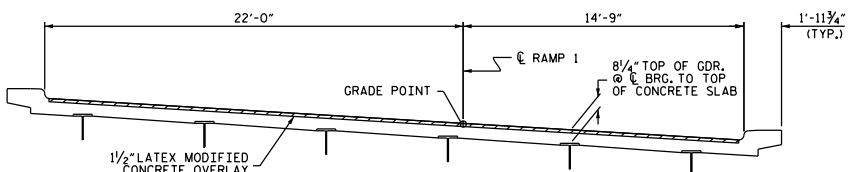

TYPICAL SECTION  
SPANS 9 & 10

NOTE: PROPOSED SUPER ELEVATIONS  
TO MATCH EXISTING.

PROJECT NO. BP-5300M  
 COUNTY: MECKLENBURG  
 DECK REPAIR BRIDGE No. 309

STATE OF NORTH CAROLINA  
 DEPARTMENT OF TRANSPORTATION  
 RALEIGH

TYPICAL SECTIONS

DRAWN BY: CLB DATE: 11/11  
 CHECKED BY: DCM DATE: 11/11

REVISIONS						HEET NO.
NO.	BY	DATE	NO.	BY	DATE	S-3
1			3			TOTAL SHEETS
2			4			3

\*\*\*\*\*SERIALNAME\*\*\*\*\* \*\*\*\*\*SYTIME\*\*\*\*\*

STATE OF NORTH CAROLINA  
DIVISION OF HIGHWAYS

**TRANSPORTATION MANAGEMENT PLAN**

**MECKLENBURG COUNTY**

DIVISION 10

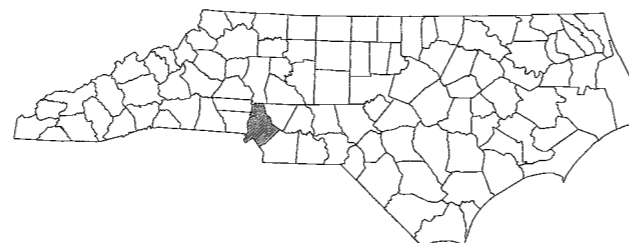

**LOCATION: BRIDGE #309 – EXIT RAMP FROM US 74 WEST TO I-277 SOUTH.**

**TYPE OF WORK: BRIDGE REHABILITATION**

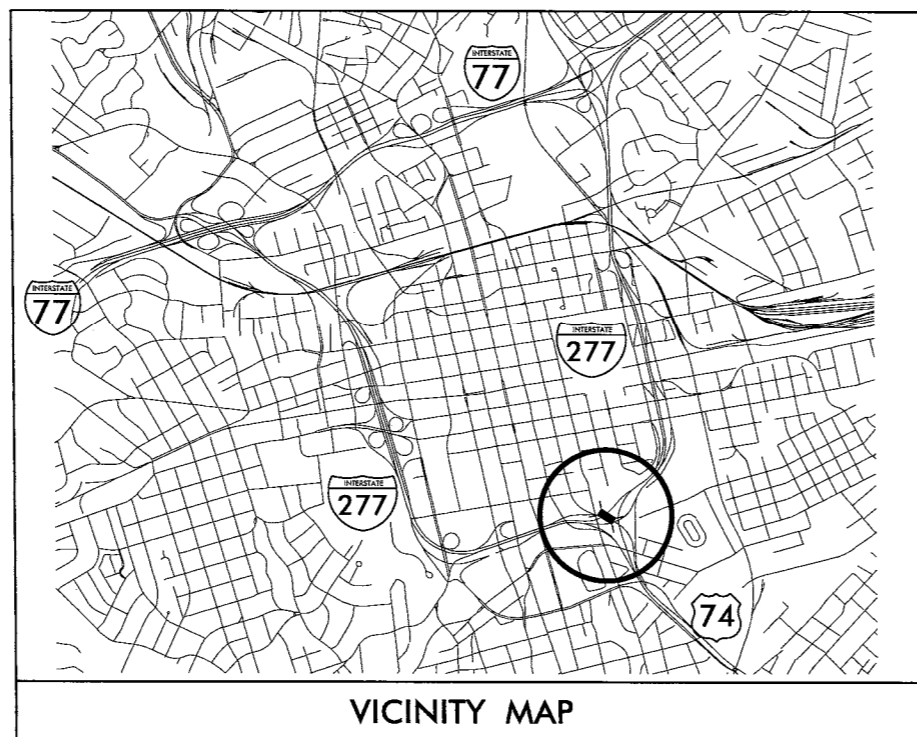

**INDEX OF SHEETS**

SHEET NO.	TITLE
TMP-1	TITLE SHEET
TMP-1A	LIST OF ROADWAY STANDARD DRAWINGS & LEGEND
TMP-2	GENERAL NOTES
TMP-3	PHASING
TMP-4, 4A, 4B	I-277 SOUTH EXIT RAMP ROAD CLOSURE
TMP-4C	I-277 SOUTH EXIT RAMP ROAD CLOSURE DETOUR SIGNING AT DAVIDSON ST.
TMP-5, 5A, 5B	LANE CLOSURE FOR LEFT LANE WORK AREA ON BRIDGE #309
TMP-6, 6A, 6B	LANE CLOSURE FOR RIGHT LANE WORK AREA ON BRIDGE #309
TMP-7	US74 EAST-TRAFFIC CONTROL UNDER BRIDGE #309 DURING HYDRO-DEMOLITION OPERATION
TMP-8	NC27 EAST-( E. 7TH ST.)-TRAFFIC CONTROL UNDER BRIDGE #309 DURING HYDRO-DEMOLITION OPERATION
TMP-9	NC27 WEST-( E. 7TH ST.)-TRAFFIC CONTROL UNDER BRIDGE #309 DURING HYDRO-DEMOLITION OPERATION
TMP-10	I-277 NORTH-TRAFFIC CONTROL UNDER BRIDGE #309 DURING HYDRO-DEMOLITION OPERATION
TMP-11, 11A, 11B	I-277 SOUTH-TRAFFIC CONTROL UNDER BRIDGE #309 DURING HYDRO-DEMOLITION OPERATION
TMP-12	PAVEMENT MARKING PLAN

**TRAFFIC MANAGEMENT STRATEGY**

PROPOSED BRIDGE REHABILITATION WILL BE PERFORMED USING TIME RESTRICTED WEEKDAY NIGHTLY ROAD CLOSURES AND LIMITED WEEKEND ROAD CLOSURES. TIME RESTRICTED LANE CLOSURES ARE ALSO SPECIFIED FOR CERTAIN OPERATIONS.

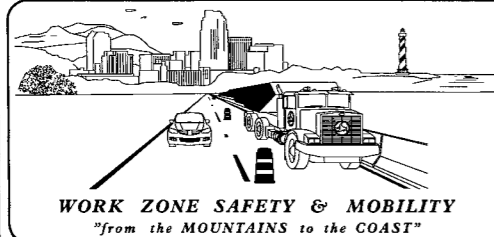

PLAN PREPARED FOR NCDOT BRIDGE MANAGEMENT UNIT  
RALEIGH, NC



PLAN PREPARED BY:

Stantec Consulting Services Inc.  
Suite 300, 801 James Franklin Road  
Raleigh, NC  
27605  
Tel. 919.851.8888  
Fax. 919.851.7024  
www.stantec.com

BETSY L. WATSON, P.E.  
TRAFFIC ENGINEER  
GEORGE KARAGEORGE  
TRANSPORTATION DESIGNER

APPROVED: *Betsy L. Watson*  
DATE: 2/14/12

SEAL

























2/10/2012 Us:\Traffic\TrafficControl\BP-5300M MECKLENBURG.TCP\Plan\_Sheets\BP-5300M.tc-TMP01.dgn

SHEET NO.  
TMP-1



WBS 45438.1.1

BP-5300M



# LEGEND

-  DIRECTION OF TRAFFIC FLOW
-  DIRECTION OF PEDESTRIAN TRAFFIC FLOW
-  WORK AREA
-  PAVEMENT REMOVAL
-  NORTH ARROW
-  TYPE III BARRICADE
-  CONE
-  DRUM
-  SKINNY DRUM
-  TUBULAR MARKER
-  CHANGEABLE MESSAGE SIGN (CMS)
-  FLAGGER
-  AUTOMATED FLAGGER ASSISTANCE DEVICE (AFAD)
-  FLASHING ARROW BOARD (TYPE C)
-  LAW ENFORCEMENT
-  TRUCK MOUNTED ATTENUATOR (TMA)
-  PORTABLE CONCRETE BARRIER (PCB)
-  TEMPORARY CRASH CUSHION
-  TEMPORARY SHORING
-  WORK ZONE SIGN-PORTABLE
-  WORK ZONE SIGN-STATIONARY
-  WORK ZONE SIGN-STATIONARY OR PORTABLE



## SIGNALS

-  EXISTING
-  PROPOSED
-  TEMPORARY

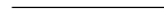

## PAVEMENT MARKINGS

-  EXISTING PAVEMENT MARKING (GRAY)
-  SKIP LINES
-  MINI-SKIP LINES
-  SOLID LINES

## PAVEMENT MARKING SYMBOLS

-  PAVEMENT MARKING SYMBOLS
-  EXISTING PAVEMENT MARKING SYMBOLS (HOLLOW)
-  PAVEMENT MARKING ALPHANUMERIC CHARACTERS

## PAVEMENT MARKERS

-  CRYSTAL / CRYSTAL
-  CRYSTAL / RED
-  YELLOW / YELLOW

# ROADWAY STANDARD DRAWINGS

THE FOLLOWING ROADWAY STANDARDS AS APPEAR IN "ROADWAY STANDARD DRAWINGS" - PROJECT SERVICES UNIT - N.C. DEPARTMENT OF TRANSPORTATION - RALEIGH, N.C., DATED JANUARY 2012 ARE APPLICABLE TO THIS PROJECT AND BY REFERENCE HEREBY ARE CONSIDERED A PART OF THESE PLANS:

STD. NO.	TITLE
1101.01	WORK ZONE ADVANCE WARNING SIGNS
1101.02	TEMPORARY LANE CLOSURES
1101.04	TEMPORARY SHOULDER CLOSURES
1101.11	TRAFFIC CONTROL DESIGN TABLES
1110.01	STATIONARY WORK ZONE SIGNS
1110.02	PORTABLE WORK ZONE SIGNS
1115.01	FLASHING ARROW BOARDS
1130.01	DRUMS
1145.01	BARRICADES
1165.01	WORK VEHICLE LIGHTING SYSTEMS AND TMA DELINEATION
1205.01	PAVEMENT MARKINGS - LINE TYPES AND OFFSETS
1250.01	RAISED PAVEMENT MARKERS - INSTALLATION SPACING
1253.01	RAISED PAVEMENT MARKERS - SNOWPLOWABLE

2/10/2012 U:\TrafficControl\BP-5300M MECKLENBURG\TCP\Plan\_Sheets\BP-5300M\_tc\_TMFOIA.dgn



Stantec Consulting Services Inc.  
801 Jones Franklin Road  
Suite 300  
Raleigh, NC 27606  
Tel. (919) 851-6866  
Fax. (919) 851-7024  
www.stantec.com  
License No. F-0672

APPROVED: \_\_\_\_\_ DATE: \_\_\_\_\_

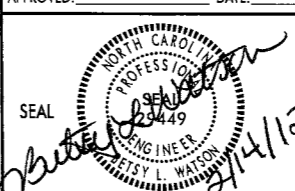

SEAL  
PATSY L. WATSON  
ENGINEER  
2/14/12



DIVISION OF HIGHWAYS  
STATE OF NORTH CAROLINA  
DEPARTMENT OF TRANSPORTATION  
WORK ZONE TRAFFIC CONTROL

LEGEND  
&  
ROADWAY STANDARD DRAWINGS

# GENERAL NOTES

THE FOLLOWING GENERAL NOTES APPLY AT ALL TIMES FOR THE DURATION OF THE PROJECT EXCEPT WHEN OTHERWISE NOTED IN THE PLAN OR DIRECTED BY THE ENGINEER.

CHANGES MAY BE REQUIRED WHEN PHYSICAL DIMENSIONS IN THE DETAIL DRAWINGS, STANDARD DETAILS, AND ROADWAY DETAILS ARE NOT ATTAINABLE TO MEET FIELD CONDITIONS OR RESULT IN DUPLICATE OR UNDESIRABLE OVERLAPPING OF DEVICES. MODIFICATION MAY INCLUDE: MOVING, SUPPLEMENTING, COVERING, OR REMOVAL OF DEVICES AS DIRECTED BY THE ENGINEER.

LANE CLOSURE TIME RESTRICTIONS

A) DO NOT CLOSE OR NARROW TRAVEL LANES ON ANY ROADWAY AS FOLLOWS:

MONDAY THRU FRIDAY 6:00AM to 9:00PM  
SATURDAY & SUNDAY 9:00AM to 9:00PM

B) DO NOT CLOSE OR NARROW TRAVEL LANES OR CLOSE ON ANY ROADWAY DURING HOLIDAYS AND SPECIAL EVENTS AS FOLLOWS:

ROAD NAME  
ALL ROADS

- 1) FOR ANY UNEXPECTED OCCURRENCE THAT CREATES UNUSUALLY HIGH TRAFFIC VOLUMES, AS DIRECTED BY THE ENGINEER.
- 2) FOR NEW YEAR'S, BETWEEN THE HOURS OF 6:00 A.M. DECEMBER 31st TO 9:00 P.M. JANUARY 2nd. IF NEW YEAR'S DAY IS ON A FRIDAY, SATURDAY, SUNDAY, OR MONDAY THEN UNTIL 9:00 P.M. THE FOLLOWING TUESDAY.
- 3) FOR EASTER, BETWEEN THE HOURS OF 6:00 A.M. THURSDAY AND 9:00 P.M. MONDAY.
- 4) FOR MEMORIAL DAY, BETWEEN THE HOURS OF 6:00 A.M. FRIDAY TO 9:00 P.M. TUESDAY.
- 5) FOR INDEPENDENCE DAY, BETWEEN THE HOURS OF 6:00 A.M. THE DAY BEFORE INDEPENDENCE DAY AND 9:00 P.M. THE DAY AFTER INDEPENDENCE DAY. IF INDEPENDENCE DAY IS ON A FRIDAY, SATURDAY, SUNDAY OR MONDAY; THEN BETWEEN THE HOURS OF 6:00 A.M. THE THURSDAY BEFORE INDEPENDENCE DAY AND 9:00 P.M. THE TUESDAY AFTER INDEPENDENCE DAY.
- 6) FOR LABOR DAY, BETWEEN THE HOURS OF 6:00 A.M. FRIDAY AND 9:00 P.M. TUESDAY.
- 7) FOR THANKSGIVING DAY, BETWEEN THE HOURS OF 6:00 A.M. TUESDAY TO 9:00 P.M. MONDAY.
- 8) FOR CHRISTMAS, BETWEEN THE HOURS OF 6:00 A.M. THE FRIDAY BEFORE THE WEEK OF CHRISTMAS DAY AND 9:00 P.M. THE FOLLOWING TUESDAY AFTER THE WEEK OF CHRISTMAS.
- 9) FOR ANY NASCAR EVENT AT THE LOWES MOTOR SPEEDWAY, BETWEEN THE HOURS OF 6:00 A.M. THE THURSDAY BEFORE THE WEEK OF THE EVENT UNTIL 9:00 P.M. THE FOLLOWING TUESDAY AFTER THE EVENT.
- 10) FOR ANY CAROLINA PANTHERS FOOTBALL GAME IN CHARLOTTE AND ANY GAMES AT THE BOBCATS ARENA, FOR THREE HOURS BEFORE THE GAME UNTIL THREE HOURS AFTER THE GAME.
- 11) FOR ANY EVENT AT THE BANK OF AMERICA STADIUM, CHARLOTTE CONVENTION CENTER AND/OR ANY OTHER ARENAS, BETWEEN 6:00AM THE FRIDAY BEFORE THE EVENT AND 9:00PM THE MONDAY AFTER THE EVENT.
- 12) FOR THE DEMOCRATIC NATIONAL CONVENTION FROM 6:00 A.M. MONDAY AUGUST 27, 2012 THROUGH 9:00 P.M. FRIDAY SEPTEMBER 7, 2012.

C) DO NOT CLOSE ANY ROADWAY OR RAMP EXCEPT WHEN ALLOWED IN THE TRAFFIC MANAGEMENT PLAN OR BY THE ENGINEER AND DURING THE FOLLOWING DAY AND TIME RESTRICTIONS:

ENTRANCE RAMP FROM 11TH ST. TO I-277 S

MONDAY THRU FRIDAY 5:00 A.M. TO 9:00 P.M.

EXIT RAMP FROM US 74 WEST TO I-277 SOUTH

MONDAY THRU THURSDAY 5:00 A.M. TO 9:00 P.M.

FRIDAY 5:00 A.M. TO 11:00 P.M.

FRIDAY 11:00 PM THRU MONDAY 5:00 A.M. WITH THE EXCEPTION THAT 3 (THREE) WEEKEND ROAD CLOSURE PERIODS BETWEEN THE HOURS OF FRIDAY 11:00 P.M. AND MONDAY 5:00 A.M. WILL BE ALLOWED.

LANE AND SHOULDER CLOSURE REQUIREMENTS

- D) LANE CLOSURES ARE REQUIRED WHEN PERSONNEL AND/OR EQUIPMENT ARE WORKING WITHIN ANY PORTION OF A TRAVEL LANE. CONDUCT THE WORK SO THAT ALL PERSONNEL AND/OR EQUIPMENT REMAIN WITHIN THE CLOSED TRAVEL LANE.
- E) INSTALL ALL LANE CLOSURES ACCORDING TO THE TRAFFIC MANAGEMENT PLAN, ROADWAY STANDARD DRAWINGS (1101.02), OR AS DIRECTED BY THE ENGINEER.
- F) REMOVE LANE CLOSURE DEVICES FROM THE LANE WHEN WORK IS NOT BEING PERFORMED BEHIND THE LANE CLOSURE OR WHEN A LANE CLOSURE IS NO LONGER NEEDED OR AS DIRECTED BY THE ENGINEER.
- G) WHEN PERSONNEL AND/OR EQUIPMENT ARE WORKING WITHIN 15 FT OF AN OPEN TRAVEL LANE, CLOSE THE NEAREST OPEN SHOULDER USING ROADWAY STANDARD DRAWING NO. 1101.04 UNLESS THE WORK AREA IS PROTECTED BY BARRIER OR GUARDRAIL OR A LANE CLOSURE IS INSTALLED.
- H) WHEN PERSONNEL AND/OR EQUIPMENT ARE WORKING ON THE SHOULDER ADJACENT TO AN UNDIVIDED FACILITY AND WITHIN 5 FT OF AN OPEN TRAVEL LANE, CLOSE THE NEAREST OPEN TRAVEL LANE UNLESS THE WORK AREA IS PROTECTED BY BARRIER OR GUARDRAIL.
- I) WHEN PERSONNEL AND/OR EQUIPMENT ARE WORKING ON THE SHOULDER ADJACENT TO A DIVIDED FACILITY AND WITHIN 10 FT OF AN OPEN TRAVEL LANE, CLOSE THE NEAREST OPEN TRAVEL LANE UNLESS THE WORK AREA IS PROTECTED BY BARRIER OR GUARDRAIL.

ROAD CLOSURES

- J) PROVIDE SIGNING AND DEVICES FOR ROAD CLOSURES ACCORDING TO THE TRAFFIC MANAGEMENT PLAN. COVER OR REMOVE ALL SIGNS AND DEVICES FOR ROAD CLOSURES WHEN NOT IN EFFECT.
- K) PROVIDE OFF-SITE DETOUR ROUTE SIGNING AS SHOWN IN THE TRAFFIC MANAGEMENT PLAN.
- L) ENSURE ALL NECESSARY SIGNING IS IN PLACE PRIOR TO ALTERING ANY TRAFFIC PATTERN.
- M) WHEN CLOSING A ROADWAY OR DRIVEWAY PLACE TYPE III BARRICADES COMPLETELY ACROSS THE ROADWAY OR FROM CURB TO CURB. ATTACH BARRICADE MOUNTED "ROAD CLOSED" SIGN R11-2 AT ALL CLOSURE LOCATIONS. IF LOCAL TRAFFIC IS TO BE MAINTAINED STAGGER THE BARRICADES TO ALLOW ACCESS.
- N) INSTALL SIGNS BEFORE BARRICADES WHEN CLOSING A ROADWAY TO TRAFFIC. REMOVE BARRICADES BEFORE SIGNS WHEN OPENING A ROADWAY TO TRAFFIC. INSTALL/REMOVE ROAD CLOSURE SIGNS AND BARRICADES IN A CONTINUOUS OPERATION AND WITHIN THE SAME CALENDAR DAY.

PAVEMENT MARKINGS AND MARKERS

- O) DURING INTERIM STAGES OF CONSTRUCTION REPLACE OBLITERATED EXISTING PAVEMENT MARKINGS WITH PAINT PRIOR TO RE-OPENING LANES TO TRAFFIC.
- P) UPON COMPLETION OF ALL OTHER CONSTRUCTION OPERATIONS AND AS A LAST ORDER OF WORK, INSTALL FINAL PAVEMENT MARKINGS (CONTRAST COLD APPLIED PLASTIC TYPE II OR III AND POLYUREA) AND SNOWPLOWABLE MARKERS. LOCATION OF ALL MARKINGS AND MARKERS SHOULD BE NOTED PRIOR TO BEGINNING CONSTRUCTION, SUCH THAT THEY CAN BE REPLACED IN THE SAME LOCATION (SEE SHEET TMP-12).

MISCELLANEOUS

- Q) USE LAW ENFORCEMENT THROUGH THE WORK AREA AND/OR INTERSECTIONS AS SHOWN IN THE PLANS OR AS DIRECTED BY THE ENGINEER. LOCATIONS SHOWN IN PLAN ARE REPRESENTATIVE AND CAN BE ADJUSTED BY THE OFFICER AS NEEDED.
- R) ALL DIMENSIONS AND STATIONS IN THE TRAFFIC MANAGEMENT PLAN AND PHASING ARE APPROXIMATE (+/-); FIELD ADJUST AS NECESSARY OR AS DIRECTED BY THE ENGINEER.
- S) ENSURE THE OVERSIZE/OVERWEIGHT PERMIT UNIT (919) 733-4740 HAS BEEN ADVISED OF THE ONGOING TRAFFIC OPERATIONS THROUGH THE DIVISION OFFICE.

2/14/2012 U:\TrafficControl\BP-5300M MECKLENBURG\TCP\Plan\_Sheets\BP-5300M.tc-TMP02.dgn

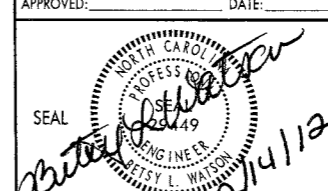
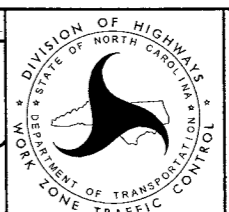
 Stantec Consulting Services Inc. 801 Jones Franklin Road Suite 300 Raleigh, NC 27605 Tel. (919) 851-8866 Fax. (919) 851-7024 www.stantec.com License No. F-0672	APPROVED: _____ DATE: _____ 		<h2 style="margin: 0;">GENERAL NOTES</h2>
---	--	---	---

## PHASING

**STEP 1:**

APPROXIMATELY ONE WEEK PRIOR TO BEGINNING ANY BRIDGE WORK, INSTALL CHANGEABLE MESSAGE SIGNS ON US 74 WEST AND PROGRAM MESSAGES FOR PUBLIC INFORMATION AS WOULD PERTAIN TO ANY UPCOMING ROAD OR LANE CLOSURES. INSTALL SIGNS IN LOCATIONS AND WITH MESSAGES SHOWN IN THE PLAN AND AS APPROVED BY THE ENGINEER.

REFER TO SHEETS TMP-4, 4A, 4B, 4C FOR CMS LOCATIONS ON US 74 WEST DURING ROAD CLOSURES.

**STEP 2:**

APPROXIMATELY THREE DAYS PRIOR TO THE FIRST EXIT RAMP ROAD CLOSURE DESCRIBED IN STEP 3 INSTALL DETOUR ROUTE SIGNS AT DAVIDSON DR. EXIT AND THE 11TH ST. ENTRANCE RAMP AS SHOWN ON SHEET TMP-4C. THESE SIGNS DO NOT HAVE TO BE COVERED ON A NIGHTLY BASIS.

**NOTE:**

IN THE EVENT LANE CLOSURES ARE REQUIRED ON BRIDGE #309 REFER TO SHEETS TMP-5,5A,5B,6,6A,6B. USE LANE CLOSURES ON BRIDGE #309 ONLY IF ALLOWED BY THE ENGINEER. THE MAJORITY OF THE WORK ON THE BRIDGE WILL BE ACCOMPLISHED BY USING ROAD CLOSURES AS DESCRIBED IN STEPS 3 AND 4.

**STEP 3:**

COMPLETE THE WORK REQUIRED OF STEPS 3A-3C USING WEEKDAY NIGHTLY ROAD CLOSURE PERIODS BETWEEN THE HOURS OF 10:00 P.M. AND 5:00 A.M. ON A MONDAY, TUESDAY, WEDNESDAY, THURSDAY OR FRIDAY AND A MAXIMUM OF THREE (3) WEEKEND ROAD CLOSURE PERIODS BETWEEN THE HOURS OF 10:00 P.M. FRIDAY AND 5:00 A.M. THE FOLLOWING MONDAY. REFER TO GENERAL NOTE C ON SHEET TMP-2 AND INTERMEDIATE CONTRACT TIMES.

FOR EACH ROAD CLOSURE PERIOD FOLLOW STEPS 3A-3C

**STEP 3A:**

INSTALL LEFT LANE CLOSURE ON US 74 WEST AND REVISE CMS MESSAGES FOR THE EXIT RAMP CLOSURE. COMPLETE INSTALLATION OF REMAINING TRAFFIC CONTROL DEVICES ALONG US 74 WEST AND CLOSE THE EXIT RAMP FROM US 74 WEST TO I-277 SOUTH. REFER TO SHEETS TMP-4, 4A, 4B, 4C

**STEP 3B:**

WITH BRIDGE #309 CLOSED TO TRAFFIC PERFORM BRIDGE REHABILITATION AND RELATED OPERATIONS. HYDRO-DEMOLITION ONLY THE AMOUNT THAT CAN BE OVERLAYED TO FINAL ELEVATION WITHIN THE CLOSURE PERIOD. GROOVING TO BE PERFORMED ACCORDING TO THE SPECIAL PROVISIONS. REPLACE ANY OBLITERATED PAVEMENT MARKINGS WITH PAINT BEFORE RE-OPENING TO TRAFFIC. BRIDGE MUST BE TRAFFIC READY PRIOR TO RE-OPENING TO TRAFFIC IN STEP 3C.

LANE CLOSURE REQUIREMENTS FOR ROADWAYS BELOW BRIDGE #309

IF CONTAINMENT FORMWORK IS NOT IN PLACE, OR WHEN FALLING WATER OR DEBRIS MAY AFFECT TRAFFIC BELOW, OR AT ANY OTHER TIMES THAT LANE CLOSURES ARE NEEDED UNDER BRIDGE #309 INSTALL LANE CLOSURES ON THE ROADWAYS BELOW AS FOLLOWS:

US 74 EAST

USE LEFT LANE CLOSURES WITH OR WITHOUT SHIFT (SHEET TMP-7).

NC 27 EAST

USE RIGHT LANE CLOSURES WITH OR WITHOUT SHIFT (SHEET TMP-8).

NC 27 WEST

USE RIGHT LANE CLOSURES WITH OR WITHOUT SHIFTS (SHEET TMP-9).

I-277 NORTH

USE LEFT LANE CLOSURES WITH OR WITHOUT SHIFTS (SHEET TMP-10).

I-277 SOUTH

USE RIGHT LANE CLOSURES (SHEETS TMP-11,11A,11B). CLOSE RAMP FROM 11TH ST. TO I-277 SOUTH AS SHOWN ON SHEET TMP-11B.



**STEP 3C:**

UPON COMPLETION OF THE WORK OF EACH ROAD CLOSURE PERIOD, REMOVE ROAD CLOSURE BARRICADES, THEN REMOVE REMAINING DEVICES ALONG US 74 AND RE-OPEN THE EXIT RAMP TO TRAFFIC. TURN OFF CHANGEABLE SIGN MESSAGES FOR ROAD CLOSURE.

**STEP 4:**

UPON COMPLETION OF ALL BRIDGE REHABILITATION OPERATIONS PLACE FINAL PAVEMENT MARKINGS AND MARKERS USING ROAD CLOSURES (REFER TO SHEETS TMP-4, 4A, 4B, 4C).

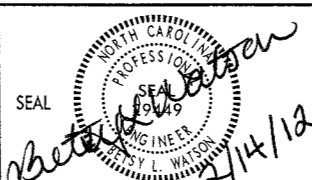
2/13/2012  
U:\TrafficControl\BP-5300M MECKLENBURG\TCP\Plan\_Sheets\BP-5300M.tc\_TMP03.dgn  
gkarageorge

 <b>Stantec</b>	Stantec Consulting Services Inc. 801 Jones Franklin Road Suite 300 Raleigh, NC 27606 Tel. (919) 851-6866 Fax. (919) 851-7024 www.stantec.com License No. F-0672	APPROVED: _____ DATE: _____ 		PHASING
---	--	--	---	---------





MESSAGE NO. 1	MESSAGE NO. 2
I-277 S NEXT EXIT	I-277 S NEXT EXIT
CHANGEABLE MESSAGE SIGN	



LAW ENF

MATCH LINE NEXT SHEET

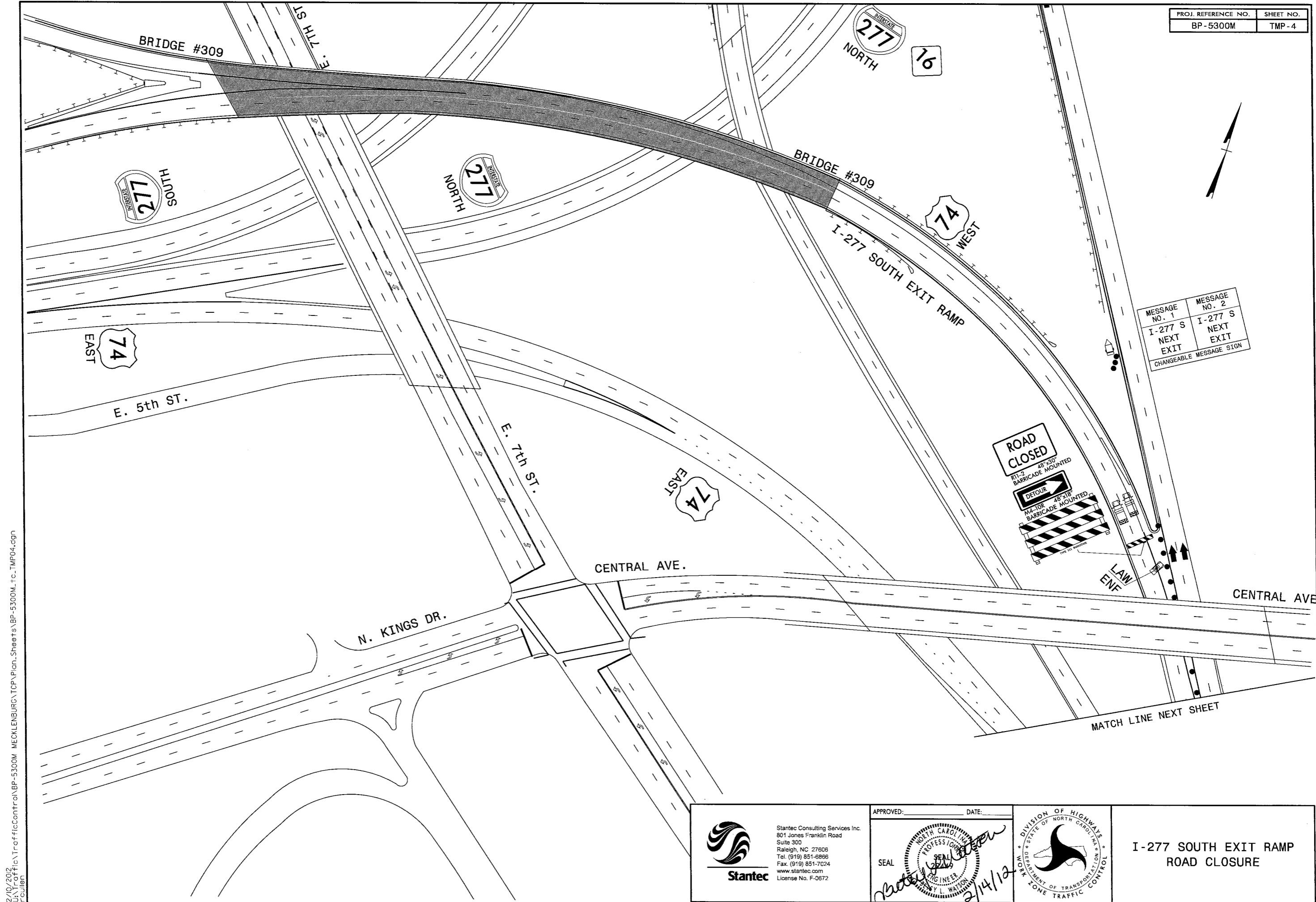

2/10/2012  
 U:\TrafficControl\BP-5300M MECKLENBURG\TCP\Plan\_Sheets\BP-5300M.tc\_TMP04.dgn  
 R. Cullen

<p>Stantec Consulting Services Inc.        801 Jones Franklin Road        Suite 300        Raleigh, NC 27606        Tel. (919) 851-6866        Fax. (919) 851-7024        www.stantec.com        License No. F-0672</p>	APPROVED: _____ DATE: _____ 	<p>DIVISION OF HIGHWAYS        NORTH CAROLINA        DEPARTMENT OF TRANSPORTATION        WORK ZONE TRAFFIC CONTROL</p>	<p>I-277 SOUTH EXIT RAMP          ROAD CLOSURE</p>
	<p>SEAL</p> <p><i>Robert J. [Signature]</i>        2/14/12</p>		

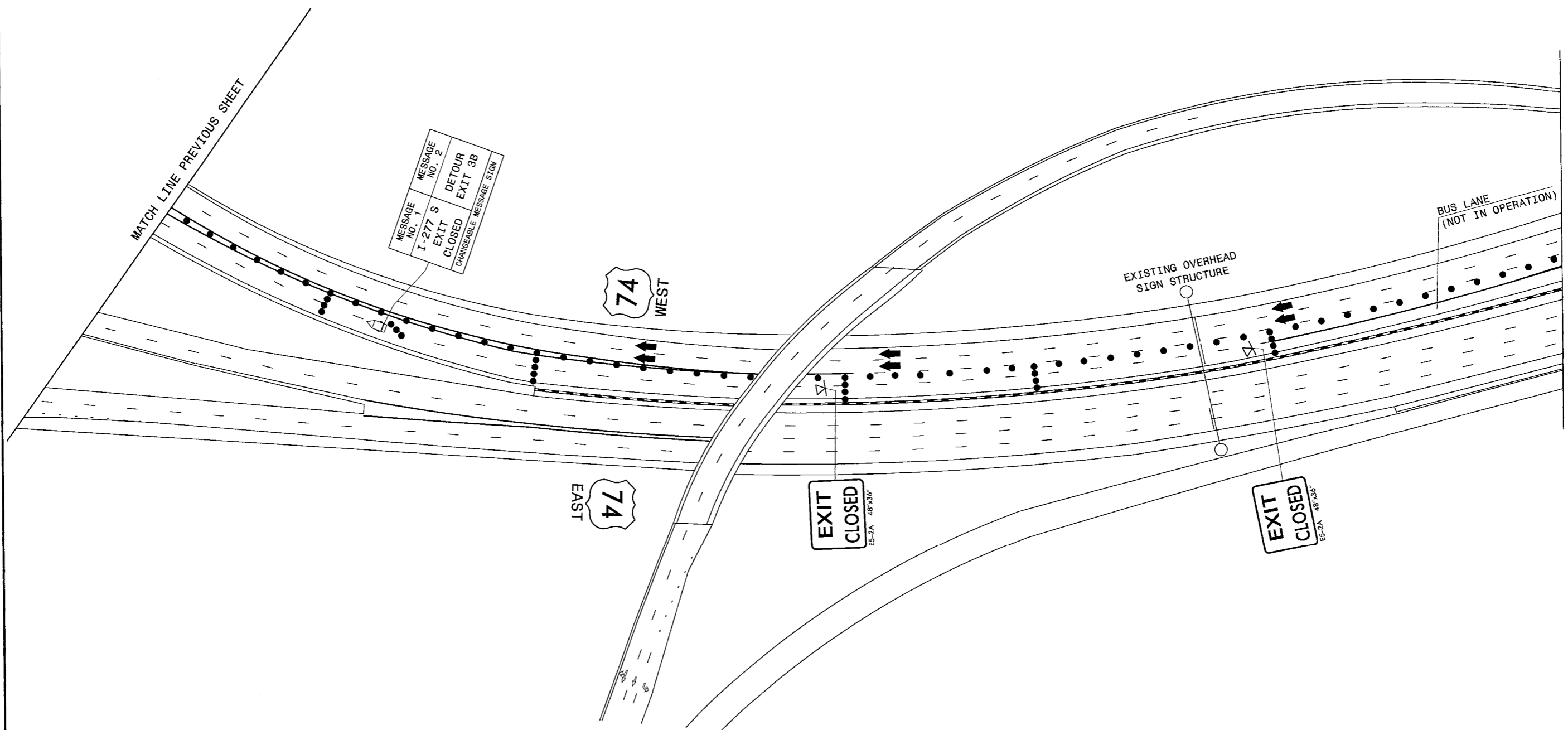

MATCH LINE PREVIOUS SHEET

MATCH LINE NEXT SHEET

MESSAGE NO. 1	MESSAGE NO. 2
I-277 S EXIT CLOSED	DETOUR EXIT 3B
CHANGEBABLE MESSAGE SIGN	

74 WEST

74 EAST



EXIT CLOSED  
ES-2A 48"X36"

EXIT CLOSED  
ES-2A 48"X36"

EXISTING OVERHEAD SIGN STRUCTURE

BUS LANE (NOT IN OPERATION)

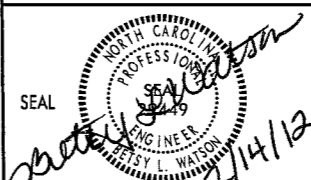
2/10/2012  
 U:\TrafficControl\BP-5300M MECKLENBURG\TCP\Plan\_Sheets\BP-5300M.tc-TMP04A.dgn  
 P.oullien

 Stantec Consulting Services Inc. 801 Jones Franklin Road Suite 300 Raleigh, NC 27606 Tel. (919) 851-6868 Fax. (919) 851-7024 www.stantec.com License No. F-0872	APPROVED: _____ DATE: _____  <i>Kelly L. Watson</i> 2/14/12		<b>I-277 SOUTH EXIT RAMP ROAD CLOSURE</b>
---	---	---	---

LOCATE 1ST SIGN APPROX.  
1/2 MILE PRIOR TO I-277S EXIT

1/2 MILE ±

MATCH LINE PREVIOUS SHEET



HAWTHORNE LN.

MESSAGE NO. 1	MESSAGE NO. 2
I-277 S EXIT CLOSING	FRI 9PM TO MON 6AM
CHANGEABLE MESSAGE SIGN	

EXAMPLE MESSAGES FOR PUBLIC INFO PRIOR TO CLOSURE

MESSAGE NO. 1	MESSAGE NO. 2
I-277 S EXIT CLOSING	FRI 10PM TO MON 5AM
CHANGEABLE MESSAGE SIGN	

MESSAGE NO. 1	MESSAGE NO. 2
I-277 S EXIT CLOSED	I-277 S DETOUR EXIT 3B
CHANGEABLE MESSAGE SIGN	

MESSAGES DURING RAMP CLOSURE

MESSAGE NO. 1	MESSAGE NO. 2
I-277 S EXIT CLOSED	I-277 S DETOUR EXIT 3B
CHANGEABLE MESSAGE SIGN	

EXISTING OVERHEAD SIGN STRUCTURE



600' MERGE TAPER

REFER TO ROADWAY STANDARD DRAWING 1101.02 SHEET 3 FOR LEFT LANE CLOSURE WARNING SIGNS AND NOTES

APPROXIMATE ARROW PANEL LOCATION. FINAL LOCATION TO BE APPROVED BY THE ENGINEER.

2/10/2012 U:\TrafficControl\BP-5300M MECKLENBURG\TCP\Plan\_Sheets\BP-5300M.tc.TMP04B.dgn rcullen

Stantec Consulting Services Inc.  
801 Jones Franklin Road  
Suite 300  
Raleigh, NC 27606  
Tel. (919) 851-6866  
Fax. (919) 851-7024  
www.stantec.com  
License No. F-0672

APPROVED: \_\_\_\_\_ DATE: \_\_\_\_\_

SEAL

DIVISION OF HIGHWAYS  
STATE OF NORTH CAROLINA  
DEPARTMENT OF TRANSPORTATION  
ZONE TRAFFIC CONTROL

I-277 SOUTH EXIT RAMP ROAD CLOSURE

OPTIONAL LAW ENFORCEMENT.  
DO NOT ALLOW TRAFFIC TO BACK UP  
ONTO I-277N.

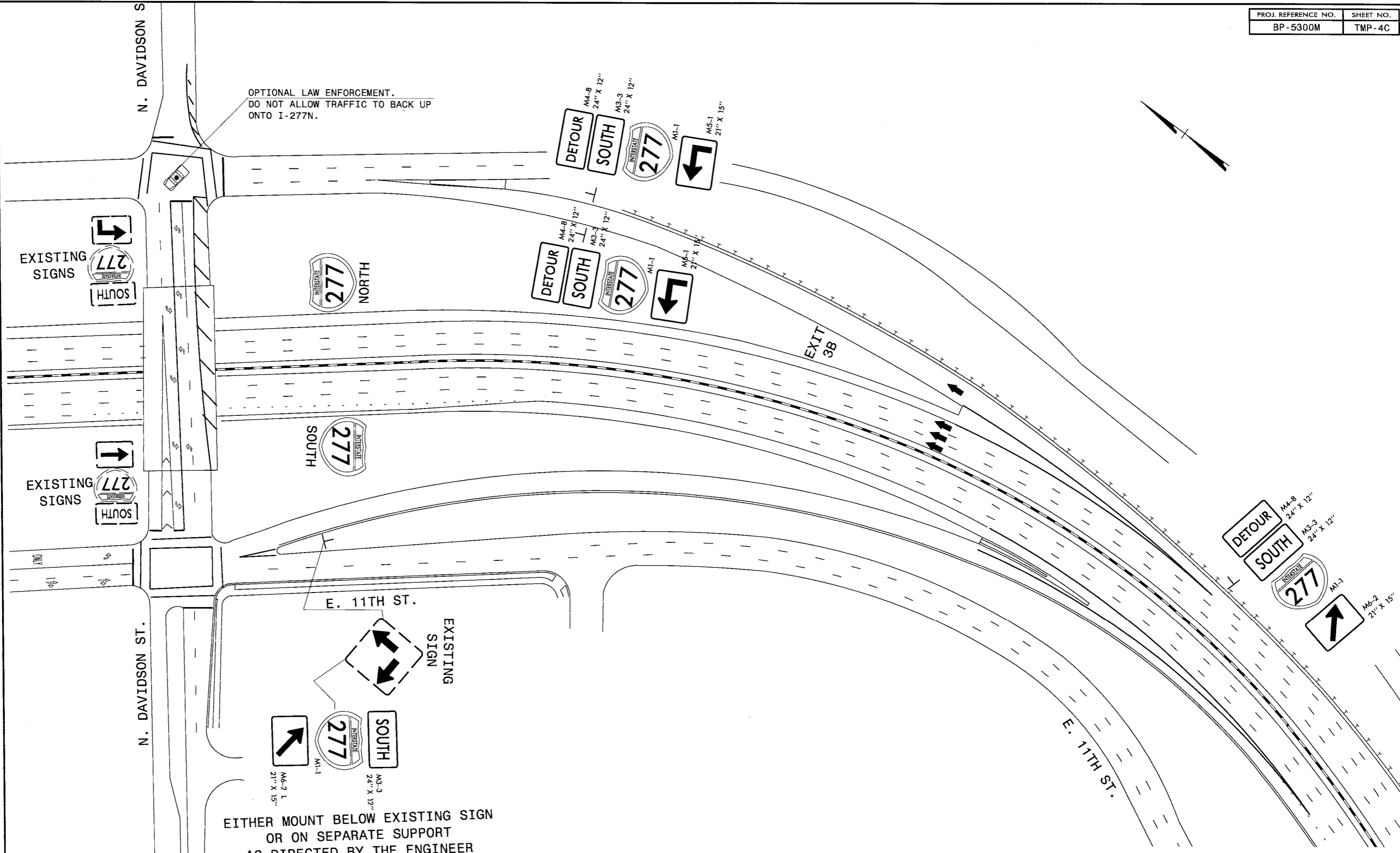
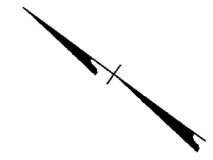

EXISTING SIGNS  
LL7  
H1NOS

EXISTING SIGNS  
LL7  
SOUTH

INTERSTATE 277 NORTH

INTERSTATE 277 SOUTH

E. 11TH ST.

EXISTING SIGN



EITHER MOUNT BELOW EXISTING SIGN  
OR ON SEPARATE SUPPORT  
AS DIRECTED BY THE ENGINEER

2/10/2012  
U:\TrafficControl\BP-5300M MECKLENBURG\TOP\Plan\_Sheets\BP-5300M.tc\_TMP04c.dgn  
rcullen

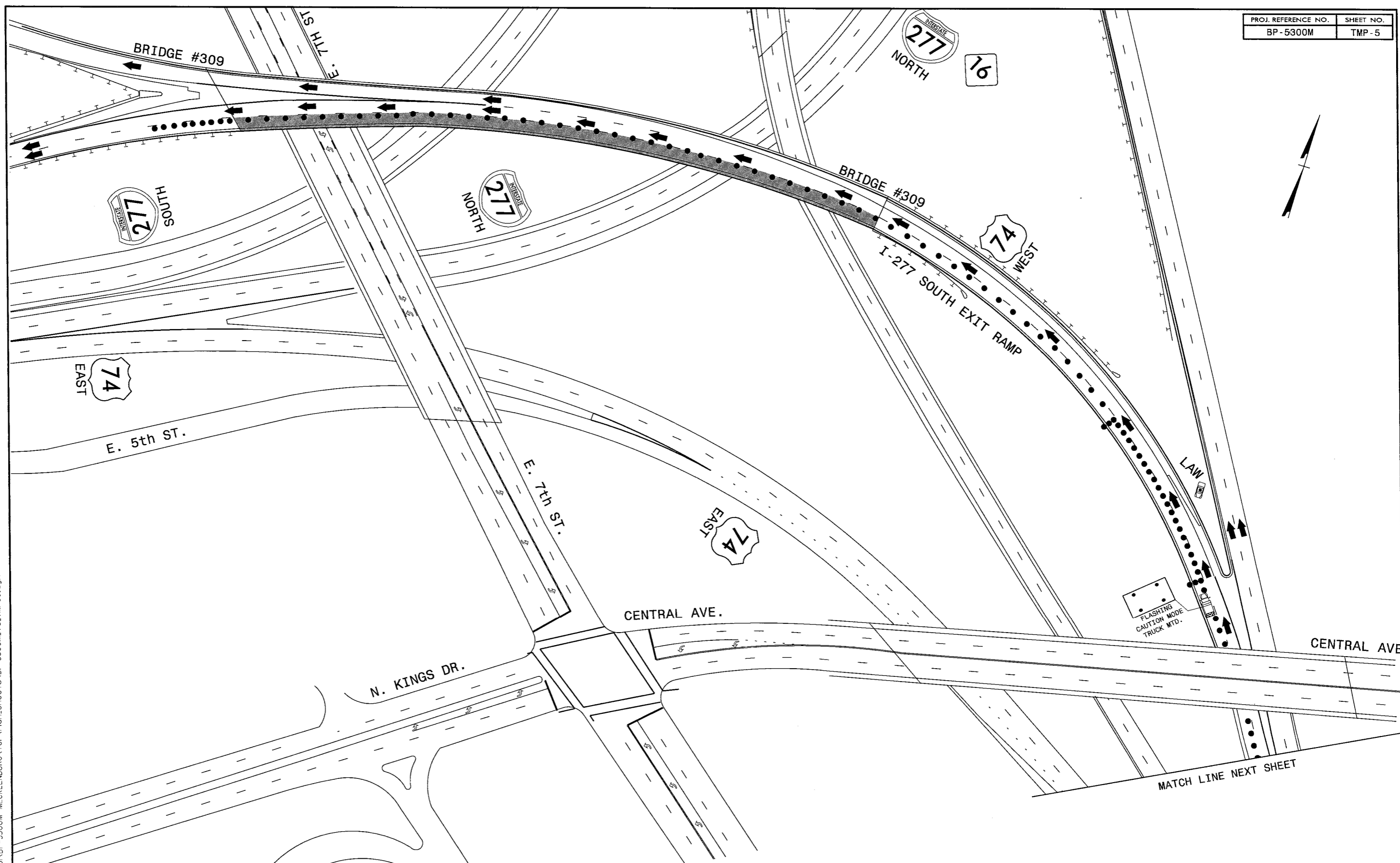
<p>Stantec Consulting Services Inc. 801 Jones Franklin Road Suite 300 Raleigh, NC 27606 Tel. (919) 851-6866 Fax. (919) 851-7024 www.stantec.com License No. F-0672</p>	APPROVED: _____ DATE: _____ 	<p>DIVISION OF HIGHWAYS STATE OF NORTH CAROLINA DEPARTMENT OF TRANSPORTATION &amp; WORK ZONE TRAFFIC CONTROL</p>	<p>I-277 SOUTH EXIT RAMP ROAD CLOSURE DETOUR ROUTE SIGNING AT DAVIDSON ST.</p>



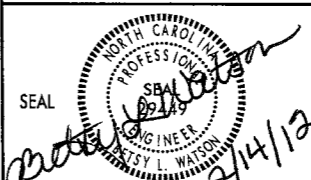

2/10/2012  
 U:\TrafficControl\BP-5300M MECKLENBURG\TCP\Plan\_Sheets\BP-5300M.tc\_TMP05.dgn  
 R. Collier

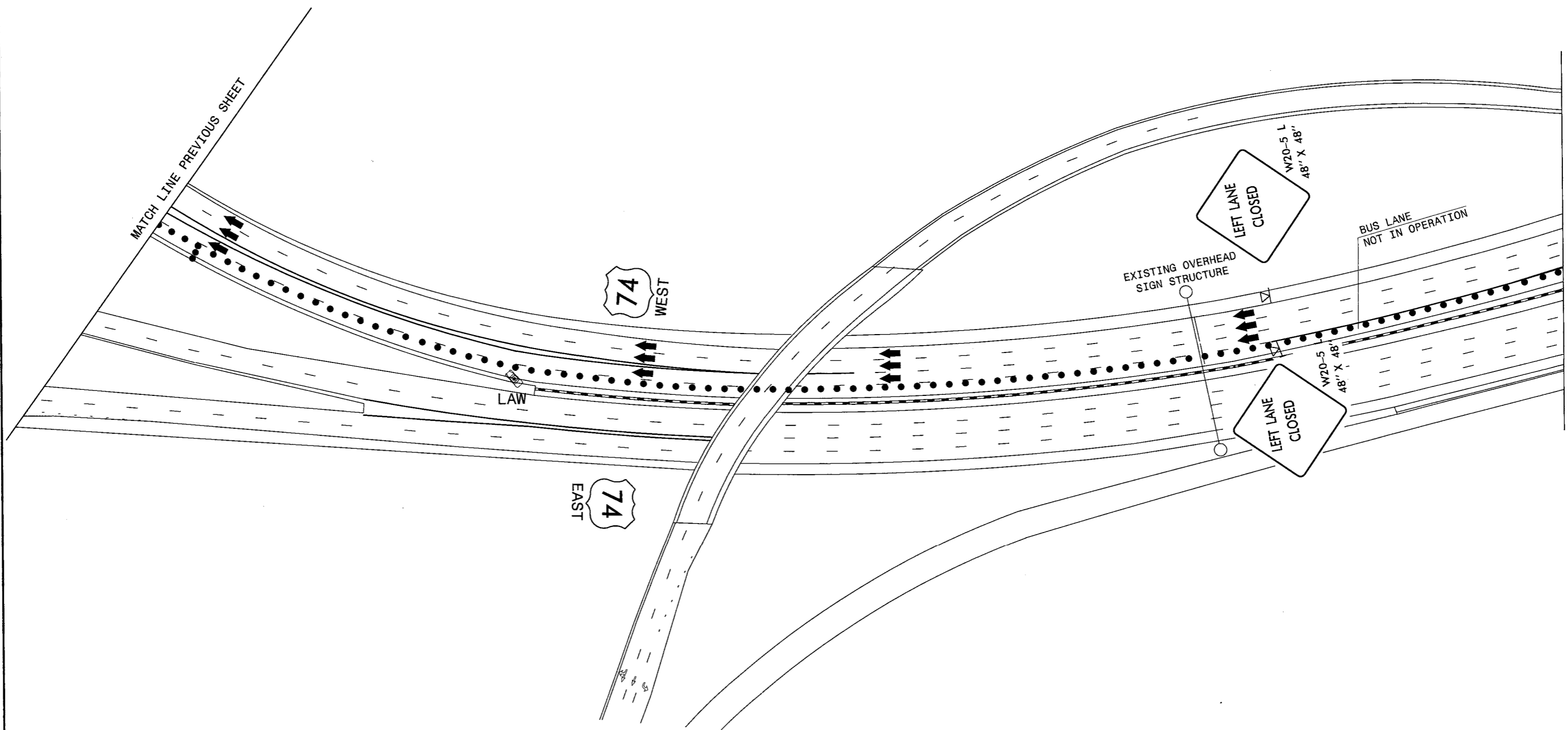
 Stantec Consulting Services Inc. 801 Jones Franklin Road Suite 300 Raleigh, NC 27606 Tel. (919) 851-6866 Fax. (919) 851-7024 www.stantec.com License No. F-0672	APPROVED: _____ DATE: _____  <i>Shelby L. Watson</i> 2/14/12		<b>LANE CLOSURE FOR          LEFT LANE WORK AREA          ON BRIDGE #309</b>
	MATCH LINE NEXT SHEET		

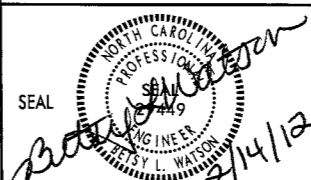

2/10/2012  
 U:\TrafficControl\BP-5300M\_MECKLENBURG\TCP\Plan\_Sheets\BP-5300M.tc\_TMP05A.dgn  
 rcullen

 <p>Stantec Consulting Services Inc.        801 Jones Franklin Road        Suite 300        Raleigh, NC 27606        Tel. (919) 851-6868        Fax. (919) 851-7024        www.stantec.com        License No. F-0672</p>	APPROVED: _____ DATE: _____ 	 <p>DIVISION OF HIGHWAYS        NORTH CAROLINA        DEPARTMENT OF TRANSPORTATION        WORK ZONE TRAFFIC CONTROL</p>	<p>LANE CLOSURE FOR          LEFT LANE WORK AREA          ON BRIDGE #309</p>
	<p><i>Patsy L. Watson</i>          2/14/12</p>		

LOCATE 1ST SIGN APPROX.  
1/2 MILE PRIOR TO I-277S EXIT

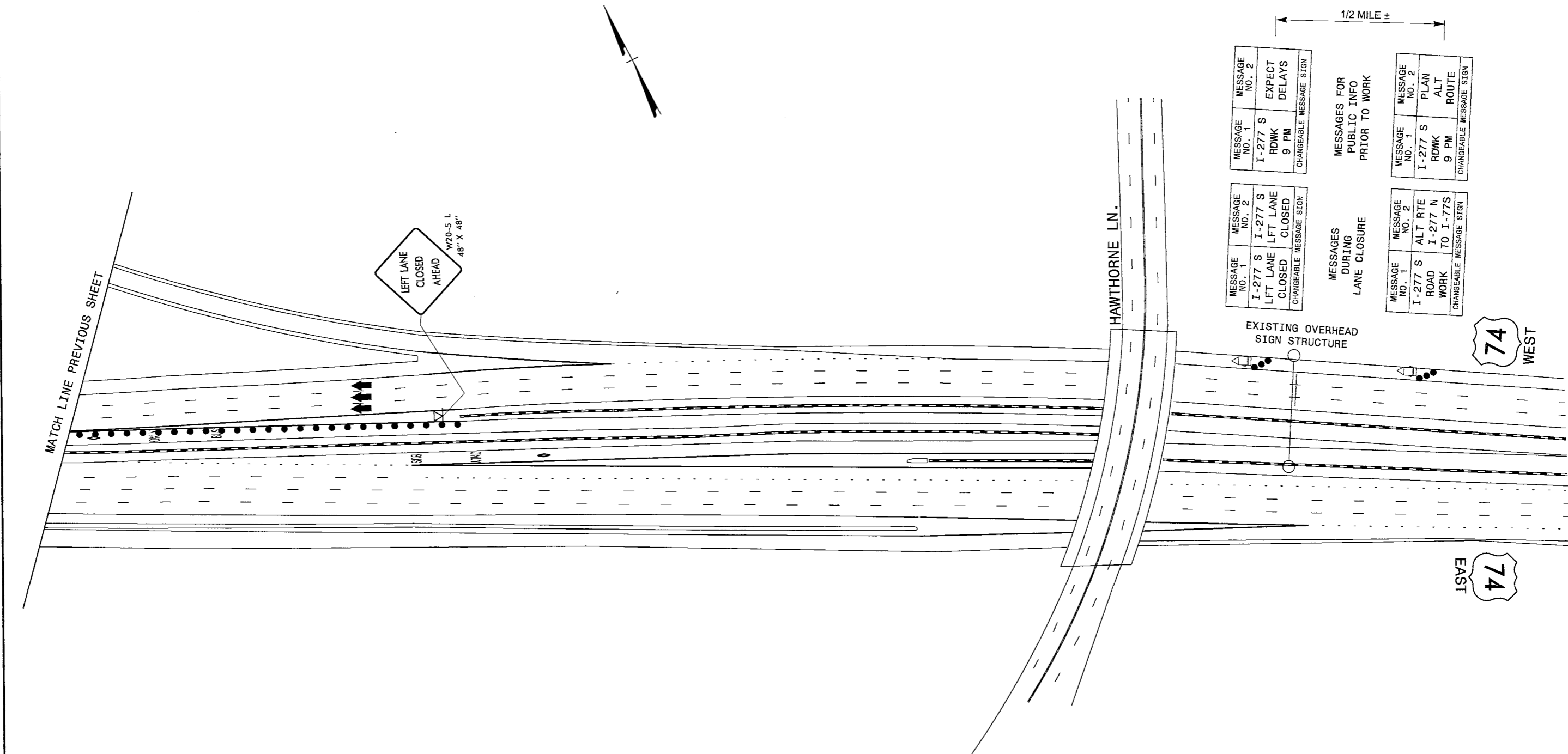

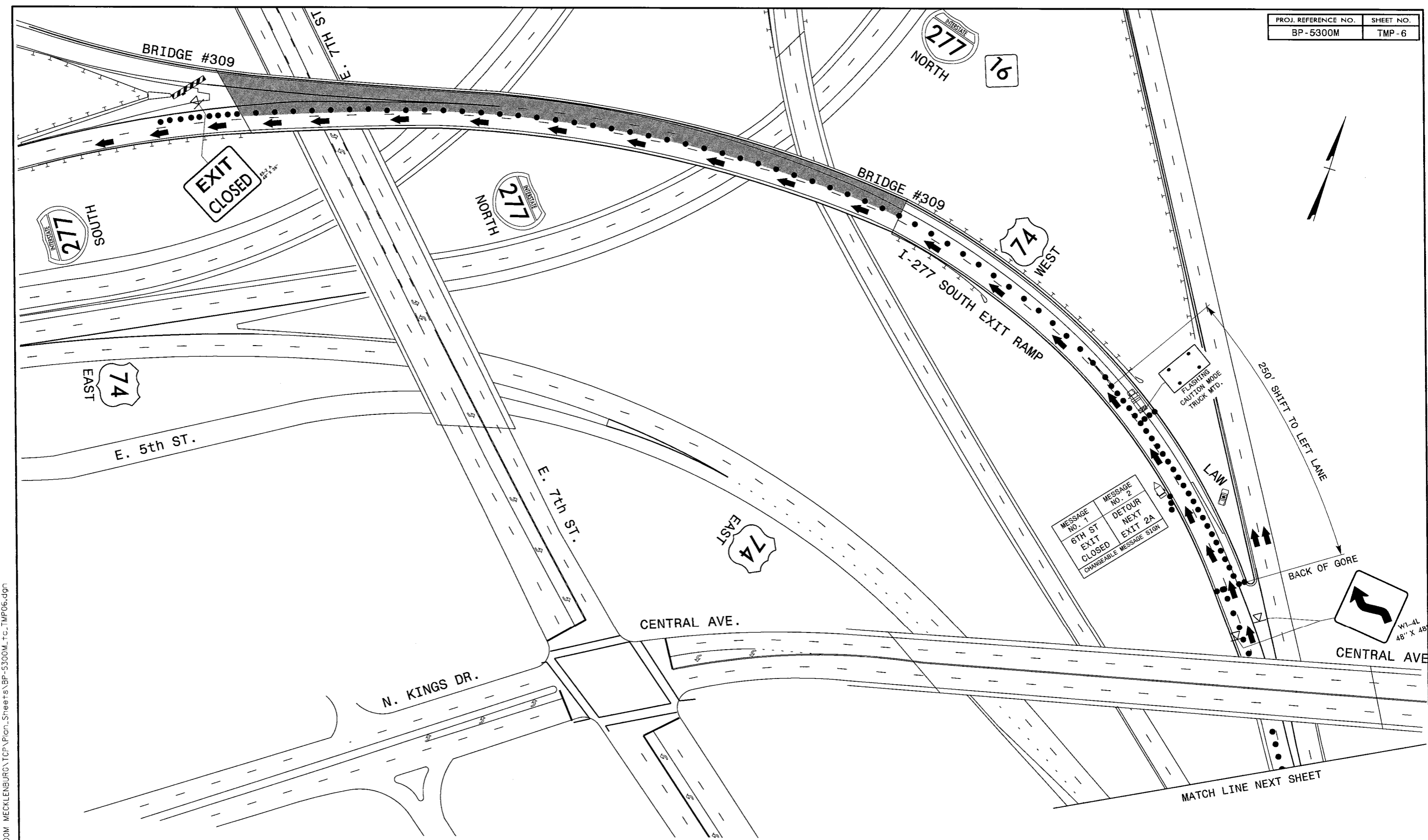

2/10/2012  
U:\TrafficControl\BP-5300M MECKLENBURG\TCP\Plan\_Sheets\BP-5300M.tc\_TMP05B.dgn  
rcullen

<p>Stantec Consulting Services Inc. 801 Jones Franklin Road Suite 300 Raleigh, NC 27606 Tel. (919) 851-6866 Fax. (919) 851-7024 www.stantec.com License No. F-0672</p>	APPROVED: _____ DATE: _____ 	<p>DIVISION OF HIGHWAYS STATE OF NORTH CAROLINA DEPARTMENT OF TRANSPORTATION WORK ZONE TRAFFIC CONTROL</p>	<p>LANE CLOSURE FOR LEFT LANE WORK AREA ON BRIDGE #309</p>



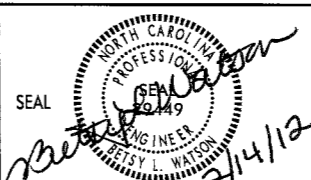

2/10/2012  
 U:\TrafficControl\BP-5300M\_MECKLENBURG\TCF\Plan\_Sheets\BP-5300M\_Tc\_TMP06.dgn  
 rcullen

 <b>Stantec</b>	Stantec Consulting Services Inc. 801 Jones Franklin Road Suite 300 Raleigh, NC 27606 Tel. (919) 851-6866 Fax. (919) 851-7024 www.stantec.com License No. F-0672	APPROVED: _____ DATE: _____  <i>Betsy L. Watson</i> 2/14/12	 DIVISION OF HIGHWAYS STATE OF NORTH CAROLINA DEPARTMENT OF TRANSPORTATION WORK ZONE TRAFFIC CONTROL	<p style="text-align: center;"><b>LANE CLOSURE FOR RIGHT LANE WORK AREA ON BRIDGE #309</b></p>
	<p style="text-align: right;">MATCH LINE NEXT SHEET</p>			

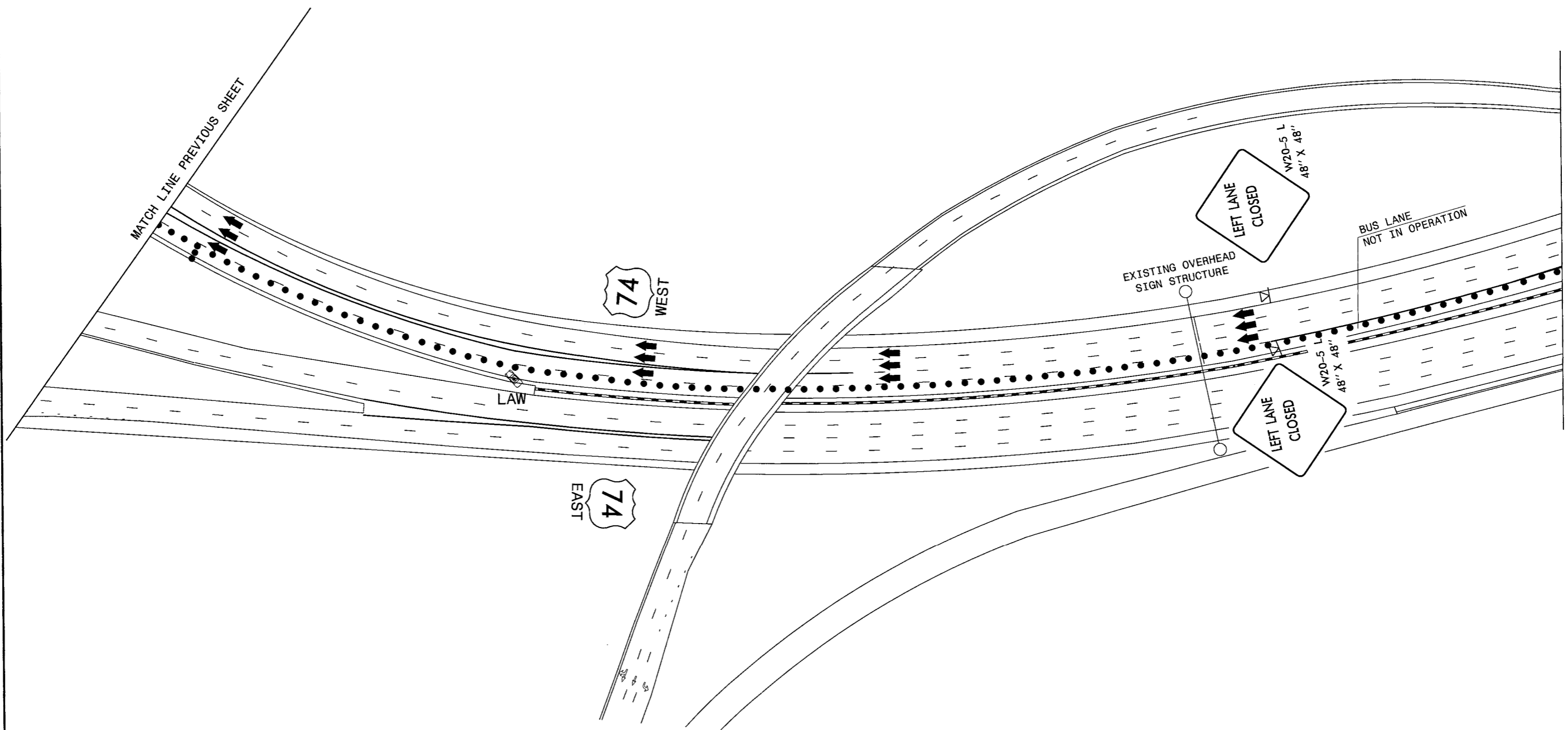

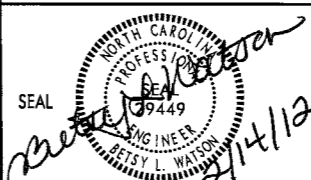

2/10/2012  
 U:\TrafficControl\BP-5300M\_MECKLENBURG\TCP\Plan\_Sheets\BP-5300M\_tc\_TMP06A.dgn  
 reullen

 <p>Stantec Consulting Services Inc.        801 Jones Franklin Road        Suite 300        Raleigh, NC 27606        Tel. (919) 851-8888        Fax. (919) 851-7024        www.stantec.com        License No. F-0872</p>	APPROVED: _____ DATE: _____			<b>LANE CLOSURE FOR          RIGHT LANE WORK AREA          ON BRIDGE #309</b>
	[Handwritten signature and date: Betsy L. Watson 2/11/12]			

LOCATE 1ST SIGN APPROX.  
1/2 MILE PRIOR TO I-277S EXIT

1/2 MILE ±

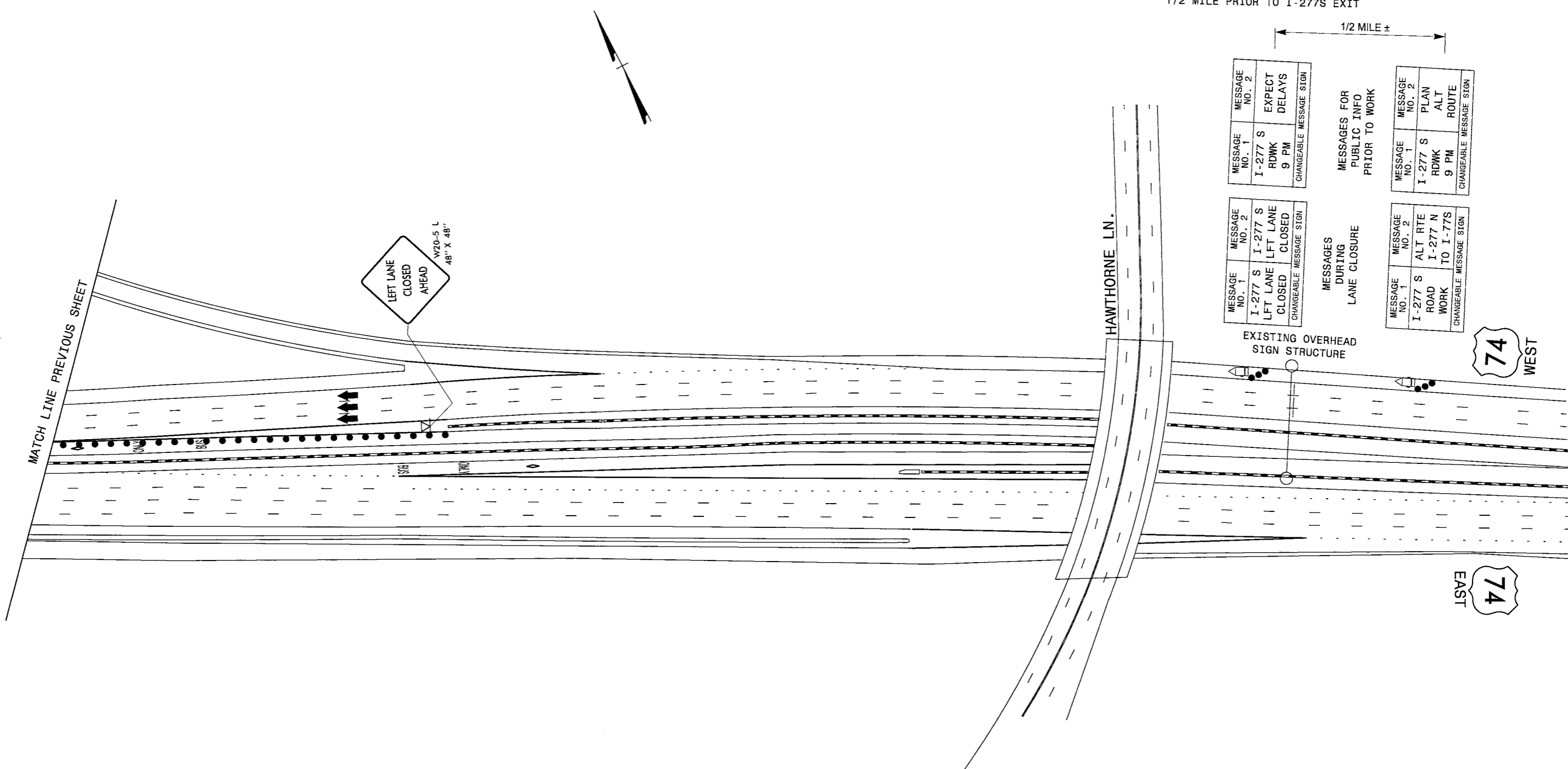

LEFT LANE  
CLOSED  
AHEAD

W20-5 L  
48" X 48"

MESSAGE NO. 1  
I-277 S  
RDWK  
9 PM  
CHANGEABLE MESSAGE SIGN

MESSAGE NO. 2  
EXPECT  
DELAYS  
CHANGEABLE MESSAGE SIGN

MESSAGES FOR  
PUBLIC INFO  
PRIOR TO WORK

MESSAGE NO. 1  
I-277 S  
RDWK  
9 PM  
CHANGEABLE MESSAGE SIGN

MESSAGE NO. 2  
PLAN  
ALT  
ROUTE  
CHANGEABLE MESSAGE SIGN

MESSAGE NO. 1  
I-277 S  
LFT LANE  
CLOSED  
CHANGEABLE MESSAGE SIGN

MESSAGE NO. 2  
I-277 S  
LFT LANE  
CLOSED  
CHANGEABLE MESSAGE SIGN

MESSAGES  
DURING  
LANE CLOSURE

MESSAGE NO. 1  
I-277 S  
ROAD  
WORK  
TO I-77S  
CHANGEABLE MESSAGE SIGN

MESSAGE NO. 2  
ALT RTE  
I-277 N  
TO I-77S  
CHANGEABLE MESSAGE SIGN

EXISTING OVERHEAD  
SIGN STRUCTURE

74 WEST

74 EAST

2/10/2012  
 U:\TrafficControl\BP-5300M MECKLENBURG\TCP\Plan\_Sheets\BP-5300M\_tc\_TMP06B.dgn  
 reulien

  
 Stantec Consulting Services Inc.  
 801 Jones Franklin Road  
 Suite 300  
 Raleigh, NC 27606  
 Tel. (919) 851-6888  
 Fax. (919) 851-7024  
 www.stantec.com  
 License No. F-0672

APPROVED: \_\_\_\_\_ DATE: \_\_\_\_\_

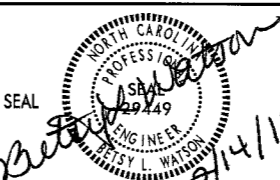
  
 SEAL  
 Ashley L. Watson  
 2/14/12



  
 DIVISION OF HIGHWAYS  
 STATE OF NORTH CAROLINA  
 DEPARTMENT OF TRANSPORTATION  
 WORK ZONE TRAFFIC CONTROL

LANE CLOSURE FOR  
RIGHT LANE WORK AREA  
ON BRIDGE #309

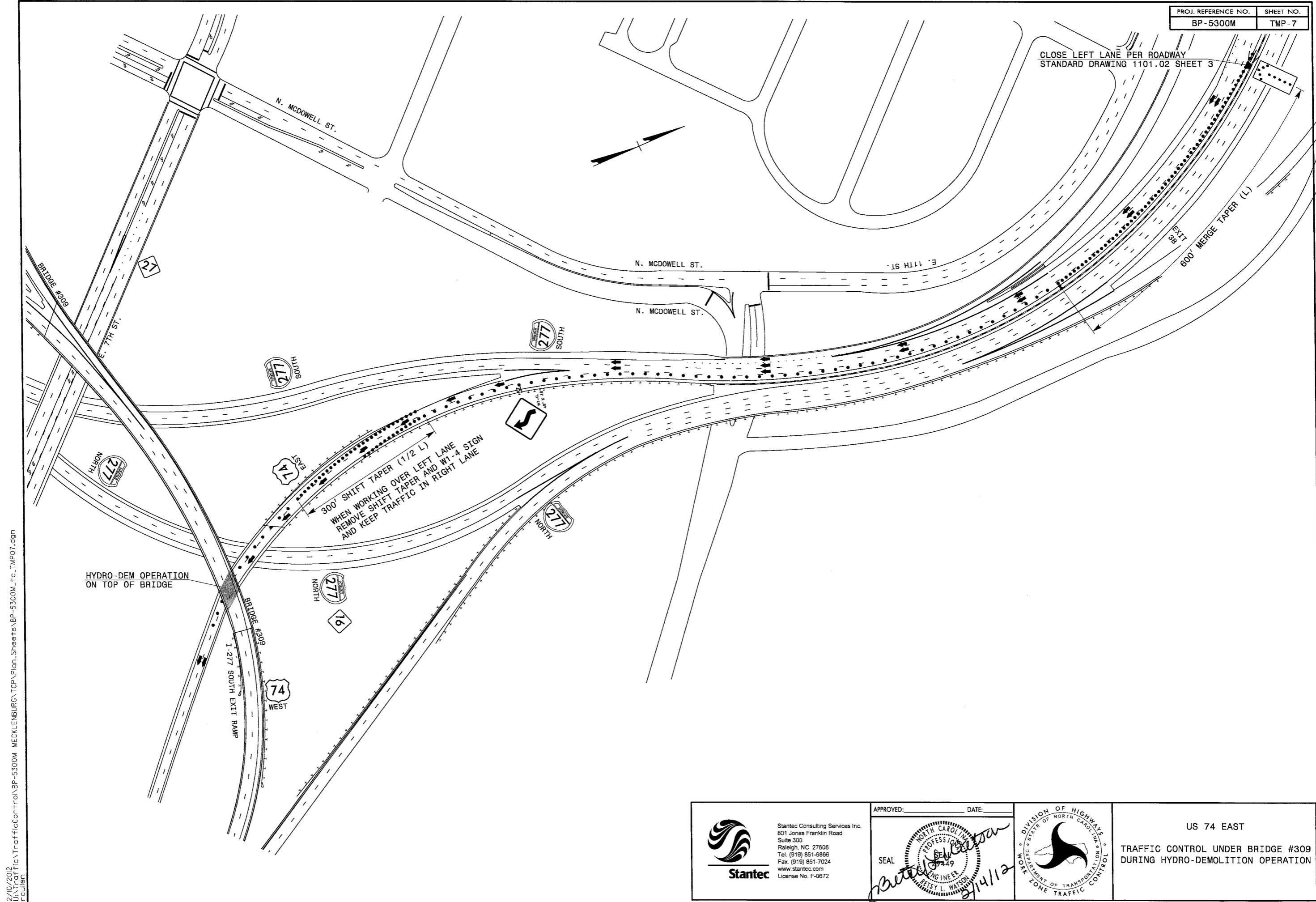
CLOSE LEFT LANE PER ROADWAY  
STANDARD DRAWING 1101.02 SHEET 3

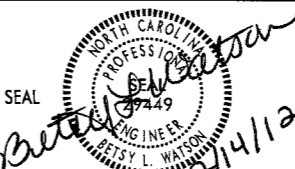

2/9/2012  
 U:\TrafficControl\BP-5300M MECKLENBURG\TCP\Plan\_Sheets\BP-5300M\_tc\_TMP07.dgn  
 r.cullen

 <p>Stantec Consulting Services Inc. 801 Jones Franklin Road Suite 300 Raleigh, NC 27806 Tel. (919) 851-6866 Fax. (919) 851-7024 www.stantec.com License No. F-0872</p>	APPROVED: _____ DATE: _____			<p style="text-align: center;">US 74 EAST</p> <p style="text-align: center;">TRAFFIC CONTROL UNDER BRIDGE #309 DURING HYDRO-DEMOLITION OPERATION</p>
	<p><i>Patsy L. Watson</i> 2/14/12</p>			

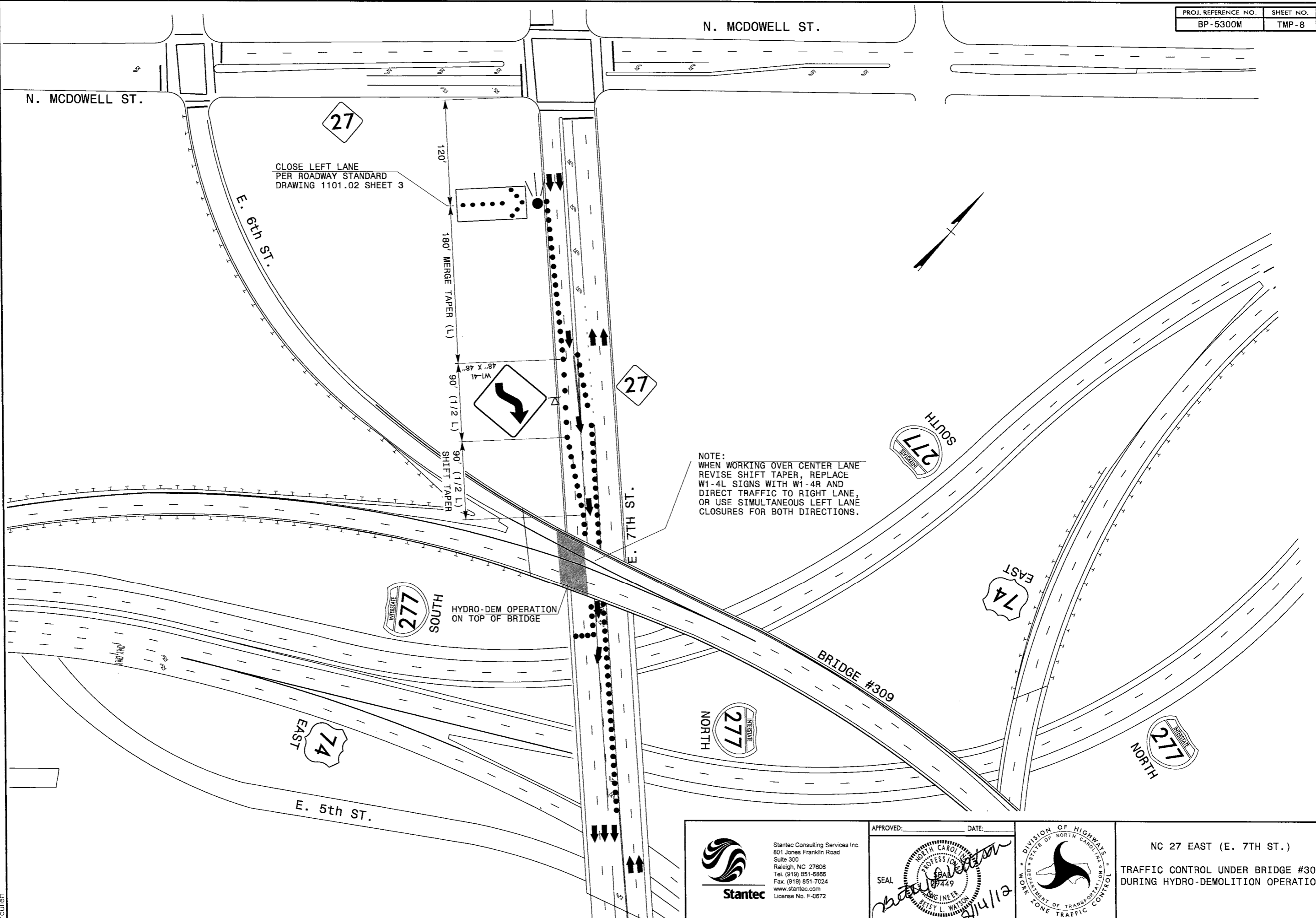

2/10/2012  
 U:\TrafficControl\BP-5300M MECKLENBURG\TCP\Plan\_Sheets\BP-5300M.tc.TMP08.dgn  
 rculien



<p>Stantec Consulting Services Inc. 801 Jones Franklin Road Suite 300 Raleigh, NC 27806 Tel. (919) 851-6866 Fax. (919) 851-7024 www.stantec.com License No. F-0872</p>	APPROVED: _____ DATE: _____			<p><b>NC 27 EAST (E. 7TH ST.)</b> <b>TRAFFIC CONTROL UNDER BRIDGE #309</b> <b>DURING HYDRO-DEMOLITION OPERATION</b></p>

NOTE:  
WHEN WORKING OVER CENTER LANE  
REVISE SHIFT TAPER, REPLACE  
W1-4L SIGNS WITH W1-4R AND  
DIRECT TRAFFIC TO RIGHT LANE,  
OR USE SIMULTANEOUS LEFT LANE  
CLOSURES FOR BOTH DIRECTIONS.

HYDRO-DEM OPERATION  
ON TOP OF BRIDGE

CLOSE RIGHT LANE PER ROADWAY  
STANDARD DRAWING 1101.02 SHEET 3

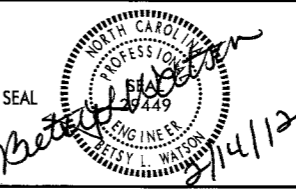
2/10/2012  
U:\TrafficControl\BP-5300M MECKLENBURG\TCP\Plan\_Sheets\BP-5300M.tc.TMP09.dgn  
rcullen

 <b>Stantec</b> Stantec Consulting Services Inc. 801 Jones Franklin Road Suite 300 Raleigh, NC 27608 Tel. (919) 851-6866 Fax. (919) 851-7024 www.stantec.com License No. F-0672	APPROVED: _____ DATE: _____  <i>H. Watson</i> 2/14/12	 DIVISION OF HIGHWAYS NORTH CAROLINA DEPARTMENT OF TRANSPORTATION WORK ZONE TRAFFIC CONTROL	<b>NC 27 WEST (E. 7TH ST.)</b> <b>TRAFFIC CONTROL UNDER BRIDGE #309</b> <b>DURING HYDRO-DEMOLITION OPERATION</b>
---	--	--	--

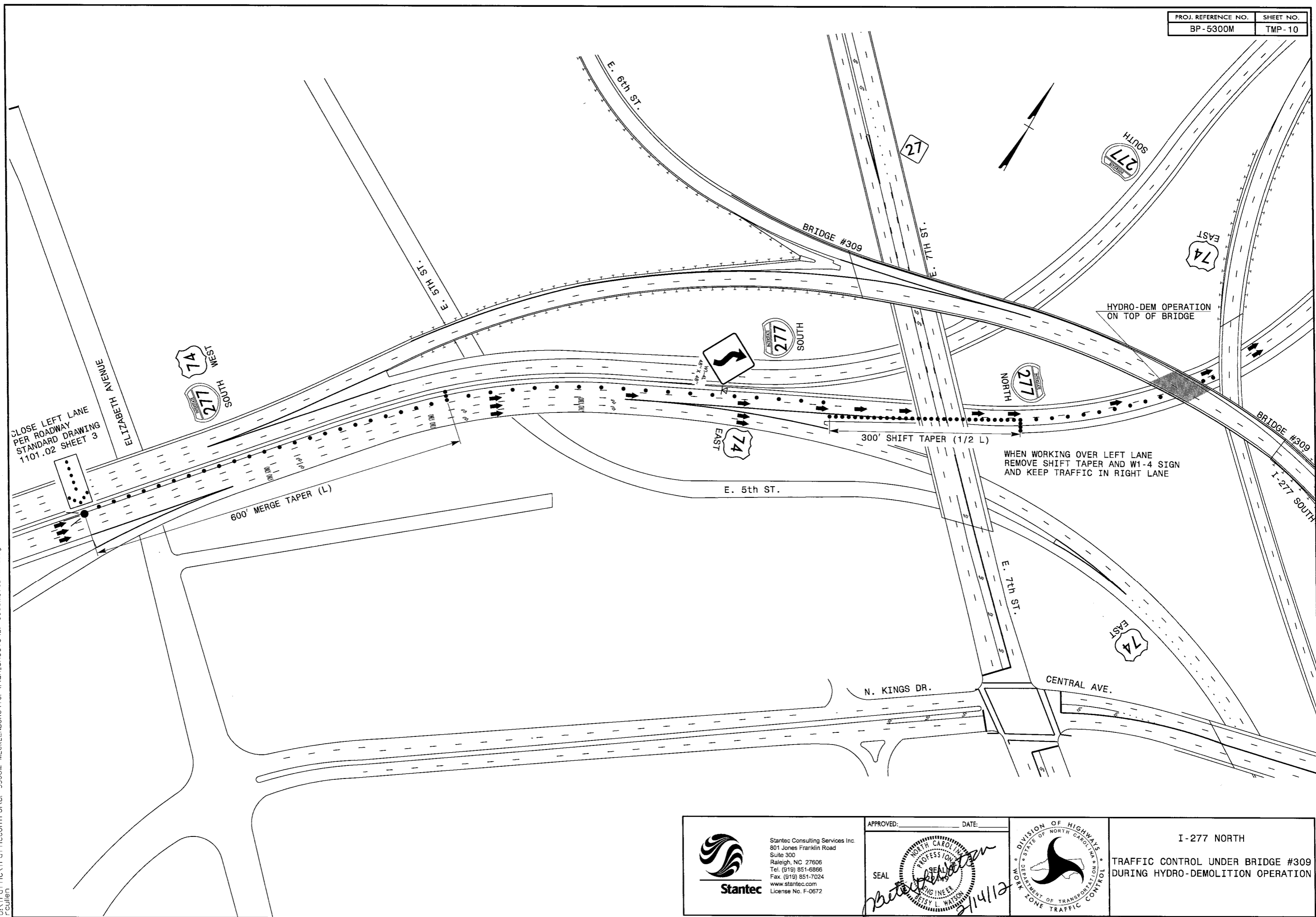



2/10/2012  
 U:\TrafficControl\BP-5300M MECKLENBURG\TCP\Plan\_Sheets\BP-5300M.tc.TMP10.dgn  
 reulen

CLOSE LEFT LANE  
 PER ROADWAY  
 STANDARD DRAWING  
 1101.02 SHEET 3

APPROVED: \_\_\_\_\_ DATE: \_\_\_\_\_

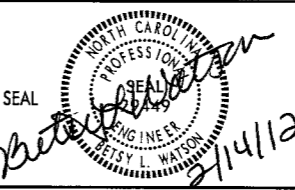
  
**Stantec**  
 Stantec Consulting Services Inc.  
 801 Jones Franklin Road  
 Suite 300  
 Raleigh, NC 27606  
 Tel. (919) 851-6866  
 Fax. (919) 851-7024  
 www.stantec.com  
 License No. F-0672

SEAL  
  
 Patsy L. Watson  
 2/14/12

  
 DIVISION OF HIGHWAYS  
 STATE OF NORTH CAROLINA  
 DEPARTMENT OF TRANSPORTATION  
 WORK ZONE TRAFFIC CONTROL

**I-277 NORTH**  
**TRAFFIC CONTROL UNDER BRIDGE #309**  
**DURING HYDRO-DEMOLITION OPERATION**

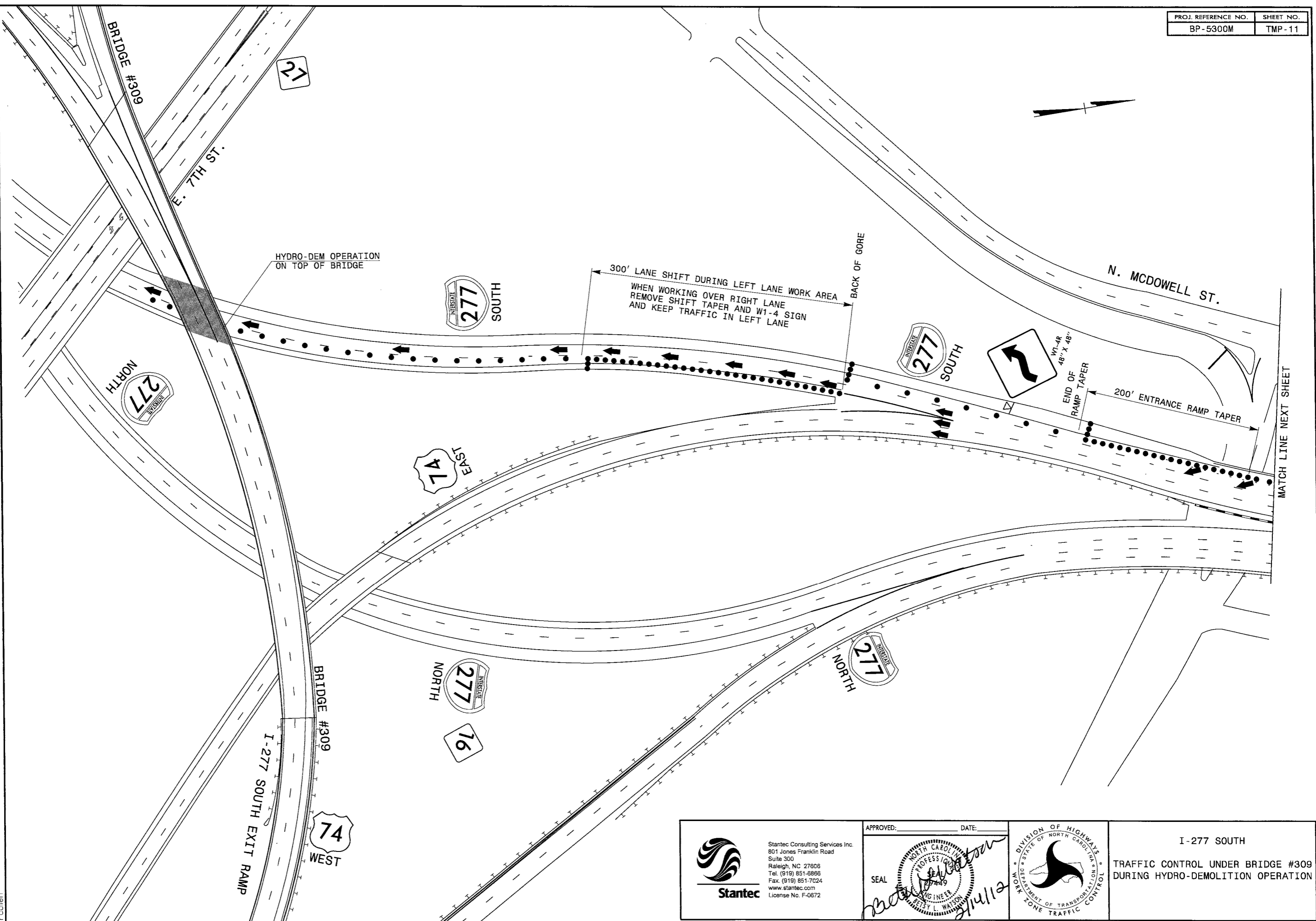

2/10/2012  
 U:\TrafficControl\BP-5300M MECKLENBURG\TCP\Plan\_Sheets\BP-5300M.tc\_TMP1.dgn  
 rculien

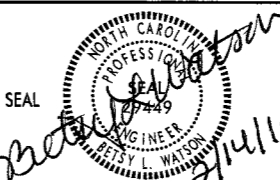

 Stantec Consulting Services Inc.  
 801 Jones Franklin Road  
 Suite 300  
 Raleigh, NC 27606  
 Tel. (919) 851-8866  
 Fax. (919) 851-7024  
 www.stantec.com  
 License No. F-0672

APPROVED: \_\_\_\_\_ DATE: \_\_\_\_\_  



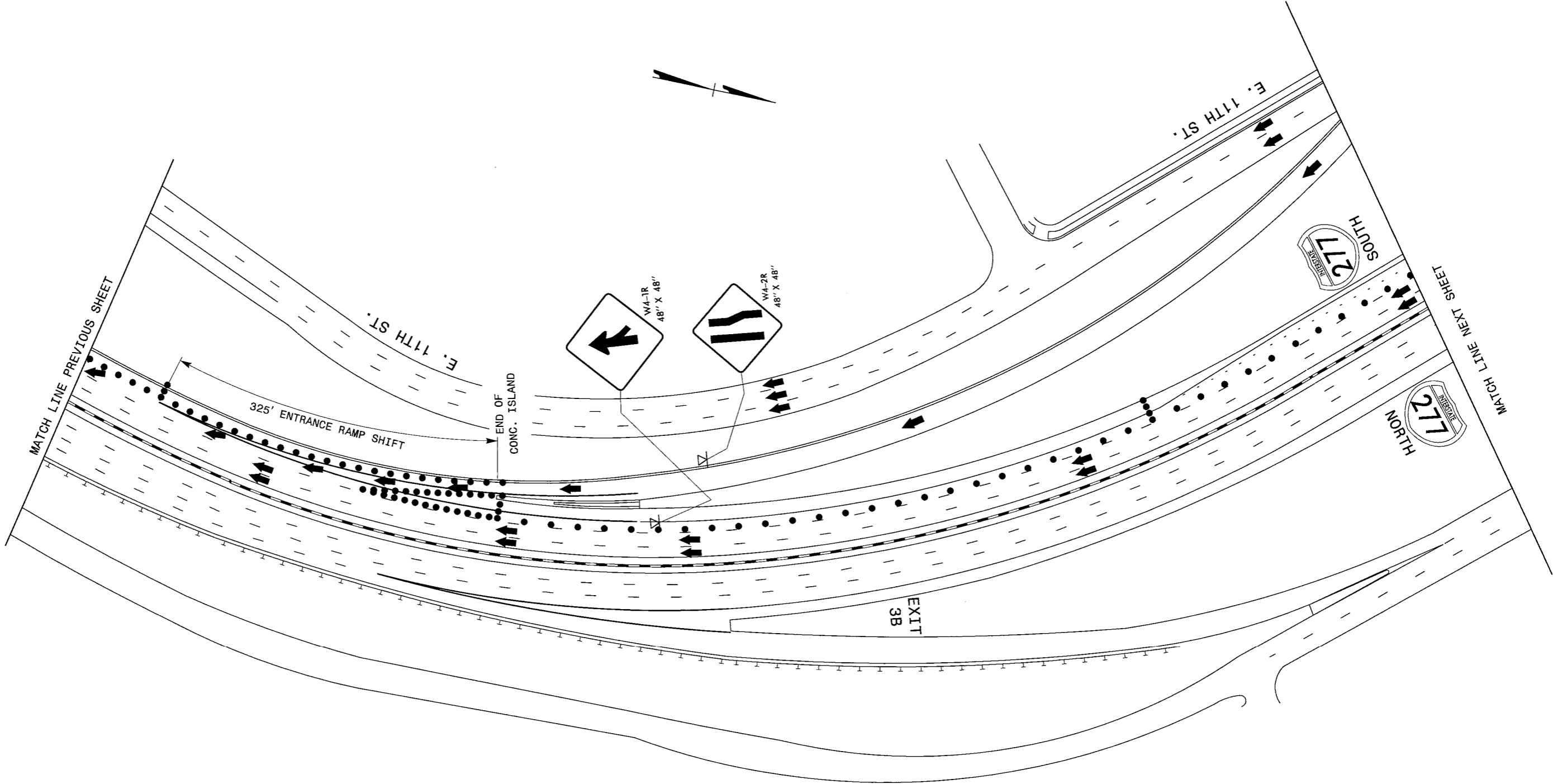

 DIVISION OF HIGHWAYS  
 STATE OF NORTH CAROLINA  
 DEPARTMENT OF TRANSPORTATION  
 WORK ZONE TRAFFIC CONTROL

I-277 SOUTH  
 TRAFFIC CONTROL UNDER BRIDGE #309  
 DURING HYDRO-DEMOLITION OPERATION

MATCH LINE NEXT SHEET

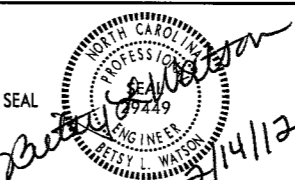

2/10/2012  
 U:\TrafficControl\BP-5300M\WECKLENBURG\TCP\Plan\_Sheets\BP-5300M.rc.TMP1A.dgn  
 reullen

 <p>Stantec Consulting Services Inc.        801 Jones Franklin Road        Suite 300        Raleigh, NC 27606        Tel. (919) 851-6866        Fax. (919) 851-7024        www.stantec.com        License No. F-0672</p>	APPROVED: _____ DATE: _____			I-277 SOUTH TRAFFIC CONTROL UNDER BRIDGE #309 DURING HYDRO-DEMOLITION OPERATION
	SEAL <i>Patsy L. Watson</i> 2/14/12			



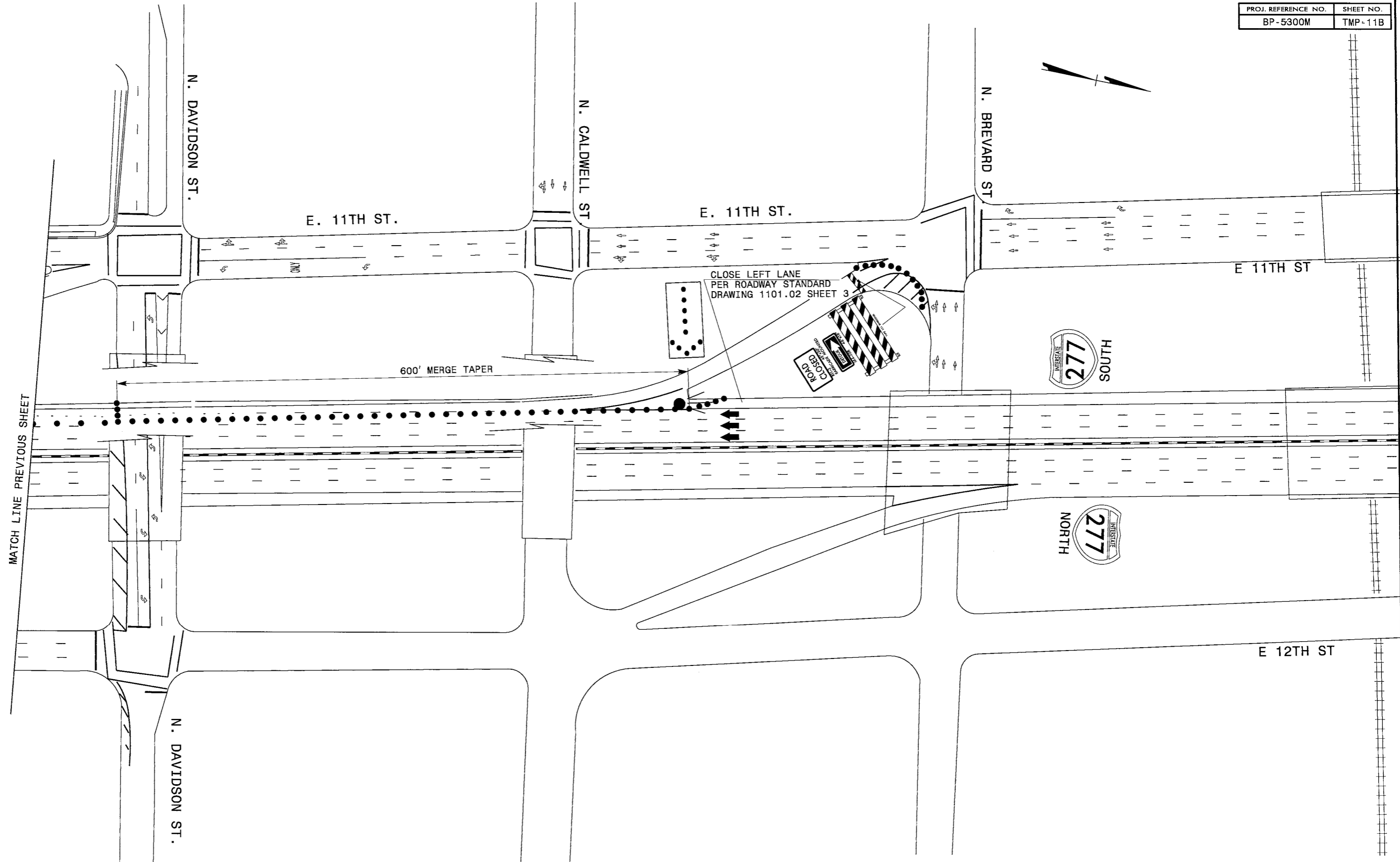

2/10/2012  
 U:\TrafficControl\BP-5300M MECKLENBURG\TCP\Plan\_Sheets\BP-5300M.tc\_TMP11B.dgn  
 rcullen



Stantec Consulting Services Inc.  
 801 Jones Franklin Road  
 Suite 300  
 Raleigh, NC 27606  
 Tel. (919) 851-8866  
 Fax. (919) 851-7024  
 www.stantec.com  
 License No. F-0872

APPROVED: \_\_\_\_\_ DATE: \_\_\_\_\_

SEAL

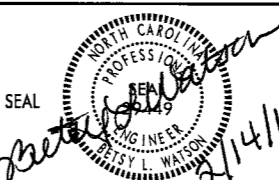

2/14/12



DIVISION OF HIGHWAYS  
 NORTH CAROLINA  
 DEPARTMENT OF TRANSPORTATION  
 WORK ZONE TRAFFIC CONTROL

I-277 SOUTH

TRAFFIC CONTROL UNDER BRIDGE #309  
DURING HYDRO-DEMOLITION OPERATION

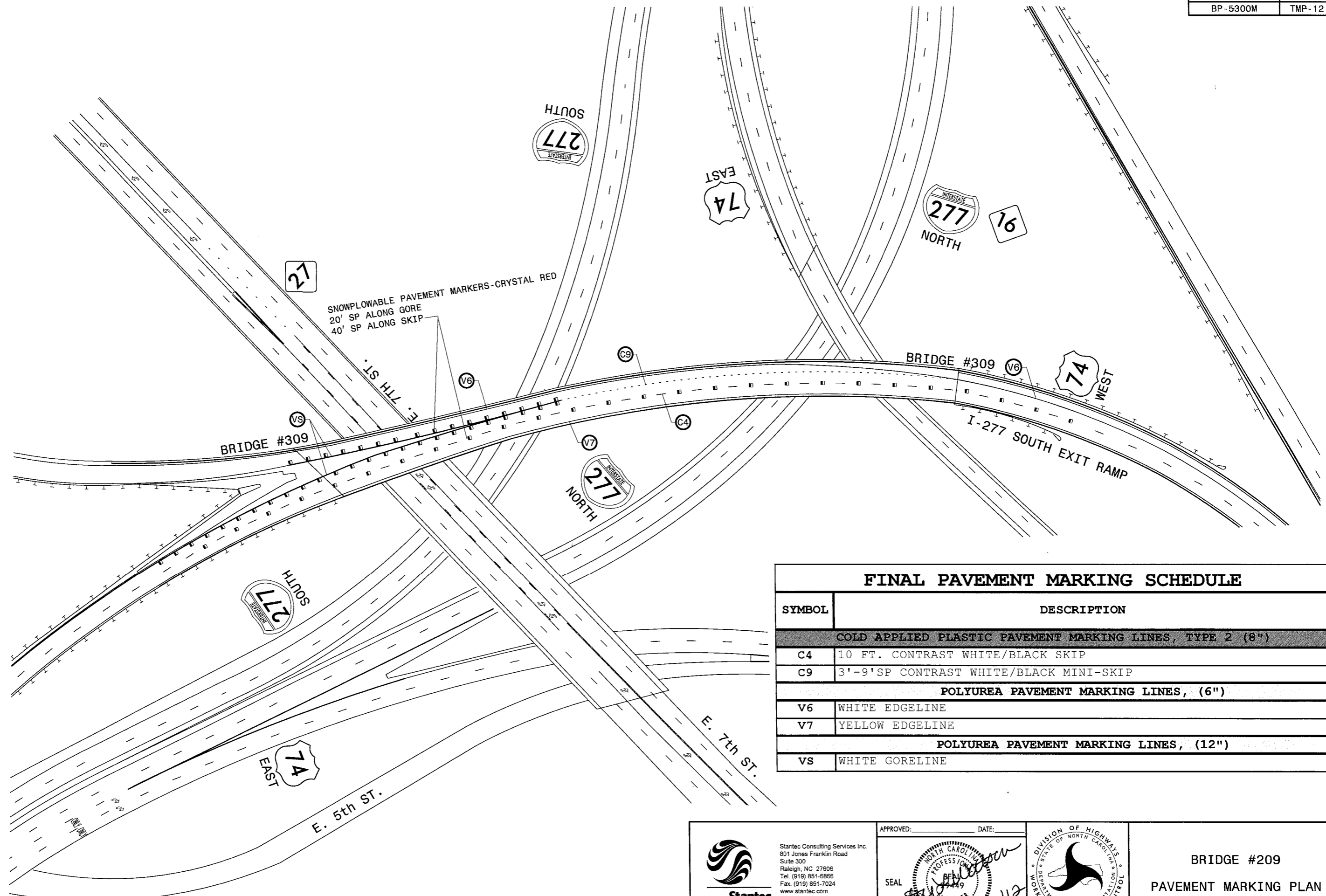

FINAL PAVEMENT MARKING SCHEDULE	
SYMBOL	DESCRIPTION
COLD APPLIED PLASTIC PAVEMENT MARKING LINES, TYPE 2 (8")	
C4	10 FT. CONTRAST WHITE/BLACK SKIP
C9	3'-9' SP CONTRAST WHITE/BLACK MINI-SKIP
POLYUREA PAVEMENT MARKING LINES, (6")	
V6	WHITE EDGELINE
V7	YELLOW EDGELINE
POLYUREA PAVEMENT MARKING LINES, (12")	
VS	WHITE GORELINE

2/13/2012  
 U:\TrafficControl\BP-5300M MECKLENBURG\TCP\Plan\_Sheets\BP-5300M.tc.TMP12.dgn  
 gkorange

 Stantec Consulting Services Inc.  
 801 Jones Franklin Road  
 Suite 300  
 Raleigh, NC 27606  
 Tel. (919) 851-8888  
 Fax. (919) 851-7024  
 www.stantec.com  
 License No. F-0672

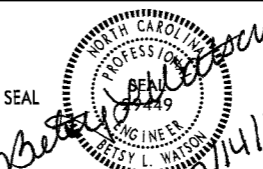
APPROVED: \_\_\_\_\_ DATE: \_\_\_\_\_  



 DIVISION OF HIGHWAYS  
 STATE OF NORTH CAROLINA  
 DEPARTMENT OF TRANSPORTATION  
 WORK ZONE TRAFFIC CONTROL

BRIDGE #209  
 PAVEMENT MARKING PLAN