

NCDOT STIP
I-4400/4700

PURPOSE AND NEED
TRAFFIC ANALYSIS
FINAL

I-26 Widening - Buncombe
and Henderson Counties

PREPARED FOR:

**North Carolina Department of
Transportation**

Project Development &
Environmental Analysis Branch

PREPARED BY:

HNTB North Carolina, PC

343 East Six Forks Road
Suite 200
Raleigh, NC 27609
NCBELS License #: C-1554

September 2013

NCDOT STIP I-4400/I-4700
I-26 WIDENING
BUNCOMBE AND HENDERSON COUNTIES
PURPOSE AND NEED
TRAFFIC ANALYSIS TECHNICAL MEMORANDUM

Prepared for:

The North Carolina Department of Transportation
Project Development & Environmental Analysis

Prepared by:

HNTB North Carolina, P.C.
343 East Six Forks Road
Suite 200
Raleigh, NC 27609
NCBELS License #: C-1554

September 2013

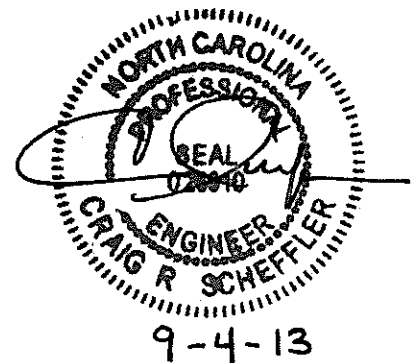

NCDOT STIP
I-4400/4700

PURPOSE AND NEED
TRAFFIC ANALYSIS
FINAL

I-26 Widening - Buncombe
and Henderson Counties

PREPARED FOR:

**North Carolina Department of
Transportation**

Project Development &
Environmental Analysis Branch

PREPARED BY:

HNTB North Carolina, PC

343 East Six Forks Road
Suite 200
Raleigh, NC 27609
NCBELS License #: C-1554

September 2013

NCDOT STIP I-4400/I-4700
I-26 WIDENING
BUNCOMBE AND HENDERSON COUNTIES
PURPOSE AND NEED
TRAFFIC ANALYSIS TECHNICAL MEMORANDUM

Prepared for:

The North Carolina Department of Transportation
Project Development & Environmental Analysis

Prepared by:

HNTB North Carolina, P.C.

343 East Six Forks Road

Suite 200

Raleigh, NC 27609

NCBELS License #: C-1554

September 2013

EXECUTIVE SUMMARY

1. Introduction

HNTB North Carolina, PC has been contracted by the North Carolina Department of Transportation (NCDOT), to develop base and future year traffic capacity analyses for NCDOT State Transportation Improvement Program (STIP) Project I-4400/I-4700, I-26 Widening in Buncombe and Henderson Counties. The analyses for the base and future design year scenarios will be used to develop the environmental documentation required by the National Environmental Policy Act (NEPA).

For the purposes of the environmental document, it was decided in a project scoping meeting on August 15, 2012 and through coordination with NCDOT that the base year scenario would use a base year of 2011 and the future design year scenario would be for the year 2040. In this meeting, a project study area was also defined that would satisfy the requirements of NEPA and potential Interchange Modification Report (IMR) requirements for the Federal Highway Administration (FHWA). Separate No-Build and Build Alternative traffic capacity analyses were conducted for both the 2011 base year and 2040 design year. **Figure 1** shows the project study area for the traffic analyses. **Appendix A** contains all figures described in this report.

2. Existing Conditions

The existing I-26 corridor south of Asheville faces increasing traffic congestion due to increasing amounts of existing and future development along the corridor, along with additional regional and interstate traffic growth. I-26 is a four-lane divided freeway in the study area, with a 60 mph speed limit north of US 25 (Asheville Highway) and a 65 mph speed limit south of that interchange. In addition, several arterial roadways and U.S. and N.C. tier highways along the facility face continuing increases in traffic demand that have resulted in congested conditions at interchange ramp terminals along the corridor.

The corridor is approximately 29 miles in length in the project study area, beginning just south of the I-26/I-40/I-240 system interchange and terminating in the south at the Holbert Creek Road interchange. The physical limits of roadway construction improvements for the I-4400/I-4700 project would be from the existing I-26/I-40/I-240 system interchange acceleration/deceleration ramps to the US 25 interchange near Hendersonville. In the project study area vicinity, there are six service interchanges and two system interchanges, two rest areas (one in each travel direction) and two NCDOT weigh stations (one in each travel direction). There are also 11 grade separations with minor roadway facilities along the study area corridor. Study area interchanges are located at:

- NC 191 (Brevard Road) – Exit 33
- NC 146 (Long Shoals Road) – Exit 37
- NC 280 (Airport Road) – Exit 40
- US 25 (Asheville Highway) – Exit 44
- US 64 (Four Seasons Boulevard) – Exit 49 (System Interchange)
- SR 1783 (Upward Road) – Exit 53
- US 25 – Exit 54 (System Interchange)
- SR 1142 (Holbert Cove Road) – Exit 54

Ten at-grade intersections are also part of the project study area, and are primarily located at the existing interchange ramp terminals with the y-line crossing arterial roadways. The general project study area for traffic analysis limits were set to satisfy FHWA requirements for an Interchange Modification Report (IMR).

Per direction from NCDOT Congestion Management, due to existing studies underway at the NC 191 (Brevard Road) and NC 280 (Airport Road) interchanges that affect the y-line facilities at these locations, HNTB will not include these interchange ramp terminals in the capacity analysis for I-4400/I-4700.

The existing geometrics, intersection traffic control, and speed limits for existing freeway network and roadways in the study area are shown schematically in **Figures 2.1 to 2.3**.

Peak hour traffic volumes were collected for study area roadways and intersections as part of the data collection effort for the *Project Level Traffic Forecast Report: TIP Projects I-4400 / I-4700 / B-5178 / I-5501* completed by the NCDOT Transportation Planning Branch (TPB) in February 2012. Traffic control information (signal plans and coordinated signal time-of-day plans) was provided by NCDOT for all signalized intersections. Other relevant study information and analysis inputs for the corridor was collected from existing aerial photography and field verified in April 2013 by HNTB staff.

3. Capacity Analysis Methodology

Per standards for the preparation of capacity analyses for TIP projects used by the NCDOT Congestion Management Section, and to ultimately satisfy requirements of an IMR for the FHWA, the I-4400/I-4700 project study area was analyzed using methodologies set forth in the *Highway Capacity Manual 2010* (Transportation Research Board, December 2010) and the accompanying Highway Capacity Software 2010 (HCS Version 6.41) for freeway facilities and unsignalized intersections. Signalized intersections were analyzed in Synchro Professional Version 7. Results for AM and PM peak hour timeframes are given as a Level-of-Service (LOS) for segments of freeway and intersections that correspond to a letter grade of LOS A through LOS F. In general, LOS D is the minimum threshold for acceptable peak hour traffic operations on the freeway segments and study area intersections, and was used as a benchmark in determining the appropriate functional design geometrics for the 2040 analysis year. Details for each analysis type are included in **Table ES-1**.

Table ES-1. Capacity Analysis Details

Analysis Type	Details
Freeway System Analysis	Segmented the I-26 network into 96 separate basic freeway, merge, and diverge areas, calculated both individual segment vehicular density and LOS and overall directional system operational statistics per HCM 2010 methods.
Signalized Intersection Analysis	Created Synchro networks that included NC 280, US 25, US 64 and Upward Road corridors in the vicinity of the interchange ramp terminals, incorporated signal timing information from NCDOT Divisions 13 and 14. Build networks only include traffic volume changes, provided in the I-4400/I-4700 Traffic Forecast, except for the Upward Road interchange, which is currently under construction. The 2040 Build networks also include the future Balfour Parkway interchange.
Unsignalized Intersection Analysis	Created unsignalized intersection files in HCS for the existing I-26 / Holbert Cove Road interchange ramp terminals. Assume that these intersections remain unsignalized in the 2040 analyses.

4. Development of Alternatives

Three alternatives were studied in this report: the No-Build Alternative, the Build 6-Lane alternative, and the Build 8-Lane Alternative. The No-Build Alternative assumes no changes to the project study corridor, other than the proposed Balfour Parkway interchange (FS 1214B), current capacity improvements at the Upward Road interchange (STIP R-4430), and basic traffic signal retiming by the 2040 design year. The Build Alternatives studied assume mainline widening of the existing I-26 facility, with no specific interchange or ramp improvements studied at this level of analysis. Some basic assumptions of how each build alternative would tie into the existing I-26 four-lane facility at the project termini were made.

5. 2011 Base Year/2040 Design Year Traffic Volume Development

Peak hour traffic volume estimates for the 2011 base year and 2040 design year were developed using daily traffic forecast information from the *Project Level Traffic Forecast Report: TIP PROJECTS I-4400 / I-4700 / B-5178 / I-5501* prepared by NCDOT TPB in February 2012. Daily traffic data, such as Average Annual Daily Traffic (AADT) estimates for study area roadway segments, truck percentages, design hour volumes (DHV-factor), and peak directional flows (D-factor) were entered into NCDOT Congestion Management Section peak hour traffic volume breakout spreadsheets for each intersection and/or interchange. This traffic volume data were then entered into capacity analysis software, as appropriate.

6. Capacity Analysis Results

Freeway Operations

The results from the HCS FreeVal analysis, shown in **Table ES-2** for freeway segments indicate that traffic operations along northbound and southbound I-26 in the project study area are mostly acceptable (LOS D or better) for 2011 base analysis year No-Build conditions, with the exception of 16 segments north of the NC 280 interchange that operate at a LOS E, given the existing traffic forecast peak hour volumes and existing geometrics. The proposed capacity expansion to 6 and 8 travel lanes eliminates these deficiencies in the 2011 base year. There will be several changes to the I-26 freeway segments due to the future Balfour Parkway interchange in the 2040 design year.

Table ES-2. I-4400/4700 Freeway Capacity Analysis Summary

Analysis Year	Scenario	Number of Freeway Segments Operating at Given LOS in at Least One AM or PM Peak Hour					
		LOS A	LOS B	LOS C	LOS D	LOS E	LOS F
2011	No-Build	0	16	36	16	16	0
	Build – 6 Lane	0	49	23	12	0	0
	Build – 8 Lane	9	57	18	0	0	0
2040	No-Build	0	0	15	19	53	7
	Build – 6 Lane	0	0	23	51	19	1
	Build – 8 Lane	0	11	56	24	2	1

In general, the additional capacity provided by 6-lane and 8-lane alternatives will provide improved freeway operations along the I-26 corridor in the 2040 design year, even though traffic forecasts for the build alternatives project daily traffic volumes increases along the facility because of the capacity expansion. In the 2040 design year, 60 of the 94 analyzed freeway segments are projected to be at or over capacity in the No-Build Alternative. The Build – 6 Lane

Alternative reduces that number to 20 segments operating at LOS E or F, with most of those located north of the NC 280 interchange. The Build – 8 Lane Alternative reduces the number of at/over capacity segments to three – all located at the southern project terminus just north of the US 25 system interchange.

Intersection Operations

The results from the HCS (unsignalized) and Synchro (signalized) intersections analyses indicate that there are some traffic congestion issues at interchange ramp terminals in the project study area in the 2011 base year, with these issues projected to increase in the 2040 design year peak hours. The Build Alternatives provide additional interstate mainline capacity, but were not studied, for the purposes of this report, to add improvements to mitigate any interchange ramp terminal operational issues.

Table ES-3 provides intersection capacity analysis results for all signalized and unsignalized intersections in the project study area for the 2011 and 2040 analysis years.

7. Crash Analysis

Crash data along a 30.36-mile section of I-26 was collected for a three (3) year period from July 1, 2009 to June 31, 2012 by HNTB from the NCDOT Traffic Survey Unit. NCDOT data for the I-26 freeway system in the project study area indicates that overall number of crashes and severity for the study area is lower than statewide averages in the last three years. The highest numbers of crashes are found along the I-26 corridor at and between the interchanges of NC 191 (Brevard Road) – Exit 33 and NC 146 (Long Shoals Road) – Exit 37. The most frequent accident types are rear end (slow or stop), fixed object and sideswipe (same direction) at 38 percent, 20 percent and 16 percent, respectively, of 1,006 total number of crashes.

8. Summary and Recommendations

The I-4400/I-4700 study area traffic capacity analysis was completed to evaluate existing and future peak hour traffic operations along I-26 and its study area interchanges to determine if initial study alternatives meet the purpose and need for the project. Three alternatives were analyzed in this study – the No-Build Alternative and the Six and Eight-Lane Widening Build Alternatives.

- The No-Build alternative assumes that no changes will be made to study area roadways in terms of geometric or traffic control improvements – other than changes to improve signal timings during AM and PM peak hours, along with the addition of the proposed Balfour Parkway interchange north of Hendersonville and improvements currently under construction for Upward Road in the vicinity of I-26. Even with improvements to signal timing that optimize projected 2040 peak hour traffic flows, several operational issues are present and will worsen at the US 25 (Asheville Highway) interchange, along with potential future operations issues at two intersections along US 64 in the vicinity of its interchange with I-26. Additionally, the No-Build Alternative fails to provide adequate freeway traffic operations for a majority of the project study area corridor in the 2040 design year with 60 of 94 freeway segments projected to operate at a LOS E or F in at least one AM or PM Peak hour.
- The Build – 6 Lane alternative assumes that I-26 will be widened for an additional travel lane in each direction from the I-40/I-240/I-26 system interchange to the US 25 system interchange. No specific design details related to which side of the existing facility were assumed, nor were any improvements assumptions made for existing auxiliary

acceleration/deceleration lanes or for necessary changes to existing overpass / underpass y-line facilities or interchange ramp terminals. Freeway operations results for this alternative indicate that it would mitigate all 2011 base year operational deficiencies, but would leave 20 segments over capacity (LOS E or F) in the 2040 design year in at least one peak hour. Most of these locations are to the north of the NC 280 (Airport Road) interchange.

- The Build – 8 Lane alternative assumes that I-26 will be widened for two additional travel lanes in each direction from the same project termini as described above for the six-lane alternative. Again, no specific design assumptions were made for this analysis with regards to the physical location of these lanes in relation to existing laneage and all the other items listed for the six-lane alternative above. Freeway operations results for this alternative indicate that it will mitigate all existing 2011 base year capacity issues, along with providing adequate capacity for 92 of 94 freeway segments along the corridor in the 2040 design year in both peak hours. The only operational issues for the Build 8 – lane alternative are located at the southern ramp termini where lanes would be added/dropped to the existing system at the US 25 interchange. This same issue exists for the 2040 design year for the 6-lane alternative. Additional study may be necessary to examine the causes of these projected operational deficiencies and what additional design possibilities exist.

Additional recommendations, based on freeway and intersection capacity analysis results from the I-4400/I-4700 study area include:

- A consideration should be made in the design of I-4400/I-4700 to examine an eight-lane facility for a portion of the I-26 corridor and transition to a six-lane facility for the remainder of the corridor. Based on the 2040 design year freeway system analysis results, the transition between a six-lane widening and eight-lane widening should be made at US 25 (Asheville Highway). South of this location, I-26 will function acceptably (LOS D or better) as a six-lane facility. North of this location, estimated peak hour traffic volumes require an eight-lane cross-section for acceptable operations for all freeway segments.
- Intersection capacity analysis results for study area ramp terminal intersections indicate that there will be a need to further examine capacity improvements at the US 25 (Asheville Highway) intersection and study alternative interchange forms to provide adequate traffic operations at this interchange.
- Additional improvements may also be needed for the US 64 corridor signalized intersections adjacent to the I-26 interchange to prevent congestion from impacting the interchange area. These improvements may not necessarily be part of alternative designs for the I-4400/I-4700 project.
- For all freeway merge, diverge, and weaving segments along the existing I-26 corridor, additional consideration should be given in the design concepts for the Build alternatives to lengthen any sub-standard acceleration and deceleration lanes to improve operations and safety for traffic flow in these areas.

NCDOT STIP I-4400/I-4700: I-26 Widening (Buncombe & Henderson Counties)

Purpose and Need Traffic Analysis Technical Memorandum

Table ES-3. 2011 Base Year / 2040 Design Year Intersection Capacity Analysis Results

Intersections	Peak Hour	2011 Base Year						2040 Design Year					
		No-Build		Build 6 Lanes		Build 8 Lanes		No-Build		Build 6 Lanes		Build 8 Lanes	
		LOS	Delay	LOS	Delay	LOS	Delay	LOS	Delay	LOS	Delay	LOS	Delay
1) NC 146 SPUI Ramps	AM	C	21.8	C	30.2	C	32.0	C	30.5	C	32.6	D	35.3
	PM	C	21.5	C	30.0	C	32.0	C	30.0	C	32.7	C	33.9
2) US 25 (Asheville Hwy) NB Ramps	AM	D	47.1	C	22.4	C	22.5	F	161.1	F	142.1	F	131.7
	PM	E	77.6	D	40.6	D	43.2	F	174.5	F	169.2	F	165.7
3) US 25 (Asheville Hwy) SB Ramps	AM	F	162.9	F	97.6	F	102.7	F	265.6	F	251.8	F	250.1
	PM	D	50.2	D	53.2	E	57.5	F	259.8	F	229.4	F	220.6
4) Future Balfour Parkway NB Ramps	AM	N/A	N/A	N/A	N/A	N/A	N/A	B	18.6	C	26.6	C	30.7
	PM	N/A	N/A	N/A	N/A	N/A	N/A	B	16.0	C	25.3	C	33.5
5) Future Balfour Parkway SB Ramps	AM	N/A	N/A	N/A	N/A	N/A	N/A	B	15.8	B	18.4	B	16.6
	PM	N/A	N/A	N/A	N/A	N/A	N/A	B	18.3	C	23.3	C	25.4
6) US 64 & Francis Road/Sugarloaf Road	AM	E	65.2	D	41.6	D	42.3	E	62.7	E	74.0	F	82.3
	PM	D	41.1	D	36.4	D	36.7	D	52.2	E	60.7	E	66.7
7) US 64 & I-26 SB Off Ramp	AM	B	13.9	B	10.8	B	11.2	B	15.2	B	16.3	B	17.1
	PM	A	9.1	B	10.1	B	10.5	B	11.9	B	13.1	B	14.0
8) US 64 & Carolina Village Road / Orr's Camp Road	AM	D	49.8	C	33.1	C	33.5	F	107.6	F	106.6	F	110.5
	PM	D	47.5	D	40.6	D	40.8	F	106.1	F	105.9	F	108.5
9) Upward Road NB Ramps	AM	C	22.3	C	22.7	C	22.8	C	32.2	C	30.2	C	31.0
	PM	D	35.9	D	38.8	D	39.7	C	28.7	C	28.4	C	29.1
10) Upward Road SB Ramps	AM	C	31.4	D	35.5	C	34.9	C	23.6	C	28.9	C	34.0
	PM	C	22.7	C	24.2	C	24.9	B	19.8	C	24.2	C	26.5
11) Holbert Cove Rd NB Ramps*	AM	B	12.6	B	12.6	B	12.6	B	14.2	B	14.6	B	14.6
	PM	B	12.2	B	12.2	B	12.2	B	15.0	B	14.5	B	14.5
12) Holbert Cove Rd SB Ramps*	AM	B	11.2	B	11.2	B	11.2	B	13.3	B	13.3	B	13.3
	PM	B	11.0	B	11.0	B	11.0	B	13.0	B	13.0	B	13.0

Delay Measured in Seconds Per Vehicle. N/A - Not Applicable, i.e. intersection is non-existent

* - LOS/Delay Data is for worst-case critical stop-controlled movement

BOLD/ITALIC = Intersection/Approach/Movement that has Operational Deficiencies (LOS E or F)

Table of Contents

APPENDIX LIST/LIST OF FIGURES.....ii
LIST OF TABLES.....ii

1. Introduction1

2. Existing Conditions2

 2.1 Project Corridor Description.....2

 2.2 Study Area Transportation Facilities2

 2.3 Study Area Interchanges/Intersections5

 2.4 Peak Hour Traffic Counts9

3. Capacity Analysis Methodology10

 3.1 Freeway Analysis Methodology12

 3.2 Signalized Intersection Analysis Methodology13

 3.3 Unsignalized Intersection Analysis Methodology14

4. Development of Alternatives14

 4.1 No-Build Alternative14

 4.2 Build Alternative – Widen I-26 to Six Lanes15

 4.3 Build Alternative – Widen I-26 to Eight Lanes15

5. 2011 Base Year / 2040 Design Year Traffic Volume Development.....16

6. 2011 Base Year Capacity Analysis Results.....16

 6.1 2011 Freeway Segment Results.....16

 6.1.1 2011 No-Build Alternative Scenario Results.....16

 6.1.2 2011 Build – 6 Lane Alternative Scenario Results.....17

 6.1.3 2011 Build – 8 Lane Alternative Scenario Results.....17

 6.2 2011 Base Year Intersection Capacity Analysis Results21

 6.2.1 2011 No-Build Alternative Scenario Results21

 6.2.2 2011 Build – 6 Lane Alternative Scenario Results21

 6.2.3 2011 Build – 8 Lane Alternative Scenario Results24

7. 2040 Design Year Capacity Analysis Results24

 7.1 2040 Freeway Segment Analysis Results.....24

 7.1.1 2040 No-Build Alternative Scenario Results.....25

 7.1.2 2040 Build – 6 Lane Alternative Scenario Results.....25

 7.1.3 2040 Build – 8 Lane Alternative Scenario Results.....25

 7.2 2040 Design Year Intersection Capacity Analysis Results30

 7.2.1 2040 No-Build Alternative Scenario Results33

 7.2.2 2040 Build – 6 Lane Alternative Scenario Results33

 7.2.3 2040 Build – 8 Lane Alternative Scenario Results33

8. Safety Evaluation34

9. I-26 Failure Year Analysis.....36

10. Conclusions and Recommendations.....37

APPENDICES

- A. Figures
- B. STIP I-4400/I-4700 Traffic Forecast Data
- C. FreeVal Freeway System Analysis Output
- D. Synchro Signalized Analysis Output
- E. Highway Capacity Software Unsignalized Analysis Output
- F. NCDOT STIP I-5501 Traffic Analysis Summary
- G. 2040 Peak Hour Breakout Spreadsheets
- H. NCDOT Traffic Safety Unit Crash Data
- I. I-26 Mainline Failure Year Analysis

Figures

- 1) Traffic Analysis Study Area
- 2.1-2.3) Existing No-Build Laneage & HCM Segment/Intersection ID Numbers
- 3.1-3.3) 2011 Base Year No-Build Laneage, Volumes, & LOS
- 4.1-4.3) 2011 Base Year Build 6 Lane Laneage, Volumes, & LOS
- 5.1-5.3) 2011 Base Year Build 8 Lane Laneage, Volumes, & LOS
- 6.1-6.2) 2040 Design Year Laneage & HCM Segment/Intersection ID Number Changes
- 7.1-7.4) 2040 Design Year No-Build Laneage, Volumes, & LOS
- 8.1-8.4) 2040 Design Year Build 6 Lane Laneage, Volumes, & LOS
- 9.1-9.4) 2040 Design Year Build 8 Lane Laneage, Volumes, & LOS

Tables

Page

1) Existing Study Area Roadways	3
2) Intersection & Freeway Segment Level of Service (LOS) Characteristics	11
3) 2011 Base Year No-Build Freeway Operations Summary	18
4) 2011 Base Year Build - 6 Lanes Freeway Operations Summary	19
5) 2011 Base Year Build - 8 Lanes Freeway Operations Summary	20
6) 2011 AM & (PM) Peak Hour Intersection Capacity Analysis Results Summary	22
7) 2040 Design Year No-Build Alternative - Freeway Operations Summary	27
8) 2040 Design Year Build - 6 Lanes Alternative - Freeway Operations Summary	28
9) 2040 Design Year Build - 8 Lanes Alternative - Freeway Operations Summary	29
10) 2040 AM & (PM) Peak Hour Intersection Capacity Analysis Results Summary	31
11) I-26 Study Area Crash Rate Comparison	34
12) I-26 Study Area Interchange and Mainline Crash Rates.....	35
13) Failure Year Analysis – I-26 Freeway Operations Summary	36

1. INTRODUCTION

HNTB North Carolina, PC has been contracted by the North Carolina Department of Transportation (NCDOT), to develop base and future year traffic capacity analyses for NCDOT State Transportation Improvement Program (STIP) Project I-4400/I-4700, I-26 Widening in Buncombe and Henderson Counties. The analyses for the base and future design year scenarios will be used to develop the environmental documentation required by the National Environmental Policy Act (NEPA).

For the purposes of the environmental document, it was decided in a project scoping meeting on August 15, 2012 and through coordination with NCDOT that the base year scenario would use a base year of 2011 and the future design year scenario would be for the year 2040. In this meeting, a project study area was also defined that would satisfy the requirements of NEPA and potential Interchange Modification Report (IMR) requirements for the Federal Highway Administration (FHWA). Separate No-Build and Build Alternative traffic capacity analyses were conducted for both the 2011 base year and 2040 design year. **Figure 1** shows the project study area for the traffic analyses. **Appendix A** contains all figures described in this report.

The I-26 corridor between Asheville and Hendersonville currently experiences congestion and queuing along the freeway facility and at several interchange ramp terminal intersection approaches, during the AM and PM peak travel periods. Without mainline and interchange ramp terminal/configuration capacity improvements, existing congestion will likely grow in the future in both location and duration. This study analyzes the following existing interchanges along the I-26 corridor (north to south):

- NC 191 (Brevard Road) – Exit 33
- NC 146 (Long Shoals Road) – Exit 37
- NC 280 (Airport Road) – Exit 40
- US 25 (Asheville Highway) – Exit 44
- US 64 (Four Seasons Boulevard) – Exit 49 (System Interchange)
- SR 1783 (Upward Road) – Exit 53
- US 25 – Exit 54 (System Interchange)
- SR 1142 (Holbert Cove Road) – Exit 54

The study also analyzes 12 interchange ramp terminal and surface street intersections in the vicinity of the locations listed above as well as freeway segments throughout the I-26 corridor.

This traffic capacity analysis technical memorandum addresses issues related to the No-Build and Build Alternative scenarios and provides detailed explanations of the tables and figures developed as a part of HNTB's capacity analysis for the I-26 project study area corridor. This memorandum incorporates intersection turning movement volumes and freeway volumes for the study area as forecasted in the *Project Level Traffic Forecast Report: TIP Projects I-4400 / I-4700 / B-5178 / I-5501* by the NCDOT Transportation Planning Branch (TPB) dated February 2012.

Two Build Alternatives are analyzed – six and eight-lane widenings of the existing facility. No specific alignments have been selected, nor have any specific improvements that may be required to existing ramp merge/diverge areas or bridges/interchange crossing facilities due to the construction of the six and eight lane widenings. These specific details will be included in

subsequent traffic analyses. Both Build alternatives will be compared to 2011 and 2040 No-Build alternative scenarios to determine the traffic operations impacts of all three potential alternative strategies for the corridor.

The following sections describe existing transportation conditions in the project study area, the capacity analysis methodology selected for this study, capacity analysis results for the 2011 base year and 2040 design year, and a traffic safety evaluation.

2. EXISTING CONDITIONS

The following pages describe the context of the proposed project, the existing transportation system in the I-4400/I-4700 project study area, and peak hour traffic data collection.

2.1 Project Corridor Description

The I-26 corridor in the project study area runs primarily north-south between Asheville and Hendersonville and is designated as a Strategic Highway Corridor in the 2008 NCDOT Strategic Highway Corridor Vision Plan. Though running north-south through this area, I-26 carries “east” and “west” designations. The current four-lane median divided freeway traverses rolling terrain with varying levels of development at existing service interchanges. Much of the corridor features lower density rural/suburban development. Interchange spacing in most cases is well over one mile between interchanges. The corridor has numerous grade separations with natural features and minor y-line local roadways and the Blue Ridge Parkway. The mainline freeway has remained essentially the same, since construction in the 1960’s. Several improvements to service interchanges and existing bridges along the facility have been recently completed, are on-going, or are planned for the near future. The corridor also includes a NCDOT truck weigh station and a rest stop.

The corridor features a 60 mph speed limit north of the US 25 (Asheville Highway) interchange, transitioning to a 65 mph speed limit south of that interchange. No specific lane restrictions, truck climbing lanes, transit/non-motorized transportation/High-Occupancy Vehicle (HOV) features currently exist.

Figure 1 in **Appendix A** shows the general project study area and the spatial relationship of the corridor to connecting transportation facilities, corporate boundaries and notable physical and natural features in the region.

2.2 Study Area Transportation Facilities

Figures 2.1 to **2.3** show schematics of the project study area which include the study area interchanges and adjacent intersections along I-26. General descriptions and information about existing study area roadways to be included in the I-4400/I-4700 intersection and freeway capacity analyses are found in **Table 1**.

NCDOT STIP I-4400/I-4700: I-26 Widening (Buncombe & Henderson Counties)
Purpose and Need Traffic Analysis Technical Memorandum

Table 1. Existing Study Area Roadways

Facility Name	Federal Functional Classification	Study Area Cross-Section	2011 AADT*	Speed Limit	Sidewalk
I-26	Interstate Highway	4-lane median divided freeway	32,000-80,000	60-65	N
NC 191 (Brevard Road)	Minor Arterial	4-lane median divided	12,700-28,900	45	S
NC 146 (Long Shoals Road)	Minor Arterial	4-lane median divided	17,600-32,600	45	S
NC 280 (Airport Road)	Other Principal Arterial	5-Lane Undivided with TWLTL	25,900-32,900	45	S
US 25 (Asheville Highway)	Other Principal Arterial	4-lane median divided	23,800-28,000	45	N
US 64 (Four Seasons Boulevard)	Other Principal Arterial	4-6-lane median divided	37,800-38,800	45	N
SR 1783 (Upward Road)	Minor Arterial	Existing 2-lane undivided Future 4-lane divided	9,800-18,200	45	N
US 25 (near Flat Rock)	Other Principal Arterial	4-lane median divided freeway	12,600	55	N
SR 1142 (Holbert Cove Road)	Minor Collector	2-lane undivided	1,400-4,000	45	N
SR 1516 (Francis Road)	Local	2-lane undivided	2,300	35	N
SR 1897 (Sugarloaf Road)	Collector	2-lane undivided	8,700	35	N
SR 1634 (Carolina Village Rd)	Collector	2-lane undivided	3,600	35	N
SR 1749 (Orr's Camp Road)	Collector	2-lane undivided	3,800	35	N

S – Some Sidewalk Present

TWLTL – Two-Way Left-turn Lane

* - AADT From 2011 Base Year NCDOT Forecast

Additional Study Area Transportation Facilities

NCDOT Rest Areas

Near milepost 41, NCDOT maintains rest area facilities in both directions along I-26. Single-lane off-ramps and on-ramps serve vehicular and truck traffic accessing the rest areas. The off-ramps immediately split into separate lanes, with separate parking facilities for truck and vehicle traffic. As part of the I-4400/I-4700 traffic analysis, freeway operations at the diverge and merge areas upstream/downstream of the rest stops will be analyzed, based on the NCDOT TPB traffic forecast data.



NCDOT Weigh Stations

Near milepost 46, NCDOT operates truck weigh station facilities in both directions along I-26. Single-lane off-ramps and on-ramps serve truck traffic accessing the scales and parking/inspection areas. No weigh-in-motion technology is currently employed along I-26 for these weigh stations. However, sensors and electronic signage is present along the freeway mainline in both directions to prevent truck queues from spilling back onto the I-26 facility. If slow-moving/idling trucks are detected near the diverge ramp gore areas, the signs will indicate that the weigh station is “closed” until the queue dissipates. As part of the I-4400/I-4700 traffic analysis, freeway operations at the diverge and merge areas upstream/downstream of the rest stops will be analyzed, based on the NCDOT TPB traffic forecast data.



Y-Line Grade Separated Facilities

There are 12 existing grade separations of the I-26 freeway with intersecting minor study area roadways that have no interchange access to I-26. The following roadway facilities within the I-4400/I-4700 project termini currently cross I-26 via overpass or underpass, but will not be studied specifically for any traffic operations impacts in this document.

- ◆ Pond Road (SR 3431) – Milepost 19.7
- ◆ Ferry Road (SR 3482) – Milepost 21.7
- ◆ Blue Ridge Parkway – Milepost 24.1
- ◆ Glen Bridge Road – Milepost 27.1
- ◆ Fanning Bridge Road (SR 3539) – Milepost 28.9
- ◆ Butler Bridge Road (SR 1345) – Milepost 31.8
- ◆ Naples Road (SR 1534) – Milepost 33.1
- ◆ Brookside Camp Road (SR 1528) – Milepost 35.0
- ◆ Clear Creek Road (SR 1503) – Milepost 36.9
- ◆ Dana Road (SR 1525) – Milepost 39.3
- ◆ Tracy Grove Road (SR 1793) – Milepost 40.3
- ◆ Crest Road (SR 1803) – Milepost 42.3

Transit/Non-Motorized Transportation

Transit

Asheville Redefines Transit (ART) and Henderson County (Apple Country Public Transit) currently provide fixed-route transit service and bus stops in the project study area along y-line arterial corridors that cross I-26.

- ◆ ART Route W2 operates along NC 191 (Brevard Road) with two stops near the I-26/NC 191 interchange and provides weekday service on 60 minute headways.
- ◆ ART Route S3 operates along NC 280 (Airport Road) with two stops near the I-26/NC 280 interchange and provides weekday service on 90 minute headways.

- ◆ Apple Country Transit – Blue Route operates along US 25 (Asheville Highway) with one stop near the I-26/US 25 interchange and provides weekday service on 60 minute headways.
- ◆ Apple Country Transit – White Route operates along US 64 with two stops just to the east of the I-26/US 64 interchange and provides weekday service on 60 minute headways.

Pedestrian

There are several short sections of sidewalk in the project study area located along y-line arterial roadways, but no pedestrian crosswalks or signal heads at intersections in the project study area.

Bicycle

Given that I-26 is an interstate facility, there are no pedestrian or bicycle facilities along the corridor. According to data from NCDOT, designated Bike Routes are present on the following facilities that cross the I-26 corridor: Brevard Road (NC 191), Blue Ridge Parkway, Long Shoals Road (NC 146), Glen Bridge Road, Fanning Bridge Road, Butler Bridge Road, Brookside Camp Road, Tracy Grove Road, and Crest Road.

2.3 Study Area Interchanges/Intersections

The following paragraphs describe existing geometrics and traffic control at all study area intersections. Refer to **Figures 2.1 to 2.4** for additional schematic details, including turning bay lengths and laneage between intersections.

NC 191 (Brevard Road) Interchange

The NC 191 service interchange with I-26 is a partial cloverleaf design with loop ramps in the northeast and southwest interchange quadrants. Signalized ramp terminals exist on both sides of the NC 191 overpass. Per direction from NCDOT staff, no at-grade study area intersections in the vicinity of this existing interchange were included in this study. The NC 191 corridor is currently being evaluated for improvements by NCDOT as part of STIP I-5504.



NC 146 (Long Shoals Road) Interchange

The NC 146 service interchange with I-26 is a single-point (SPUI) design, with the NC 146 facility forming the underpass of I-26. All interchange movements are controlled by a single traffic signal (described in detail below). The SPUI was recently constructed as STIP R-2813. Single lane on-ramps and off-ramps service the I-26 mainline facility, which has an ultimate width across the bridge for eight travel lanes on I-26.



- ◆ **NC 146 (Long Shoals Road) and I-26 Northbound/Southbound Ramps** – The intersection of NC 146 and the I-26 Northbound/Southbound on/off ramps is a six-legged, signalized intersection with five signal phases. The eastbound and westbound legs feature dual left-turn lanes, two through travel lanes and a yield-controlled right-turn lane connecting to the interstate on-ramps. The northbound and southbound interstate off-ramps feature dual left-turn lanes and exclusive right-turn lanes (that are yield-controlled). No pedestrian facilities, crosswalks or signal heads are present.

NC 280 (Airport Road) Interchange

This interchange has been previously studied in NCDOT STIP I-5501. Improvements to convert the existing traditional diamond interchange configuration to a Diverging Diamond Interchange (DDI) are currently in the final design stage and are expected to be constructed prior to the 2040 I-4400/I-4700 design analysis year. Per direction from NCDOT, the interchange ramp terminal intersection in their existing configuration and future DDI design were not included in the I-4400/4700 capacity analysis.



US 25 (Asheville Highway) Interchange

The US 25 (Asheville Highway) service interchange with I-26 is a traditional diamond interchange featuring signalized ramp terminals at either end of the US 25 overpass. The US 25 overpass contains six travel lanes. Single lane on-ramps and off-ramps are present servicing I-26. Additional ramp terminal intersection details are found below.



- ◆ **US 25 (Asheville Highway) and I-26 Southbound Ramps** – The intersection of US 25 and the I-26 Southbound Ramps is currently signalized and operates with three signal phases. The southbound approach on US 25 features protected-only left-turn phasing and has a single left-turn lane and two through lanes. The northbound approach features two through travel lanes and an exclusive right-turn lane that is yield-controlled. The eastbound off-ramp features two lanes, one becomes a shared left-turn/through lane and a signalized right-turn lane at the intersection ramp terminal. The west leg of the intersection is a one-way single lane on-ramp to I-26. No pedestrian crosswalks or signal heads are present.
- ◆ **US 25 (Asheville Highway) and I-26 Northbound Ramps** – The intersection of US 25 and the I-26 Northbound Ramps is currently signalized and operates with three signal phases. The northbound approach on US 25 features protected-only signal phasing for an exclusive left-turn lanes and has two through travel lanes. The southbound approach features two through travel lanes and an exclusive right-turn lane that is yield-controlled for on-ramp movements. The westbound off-ramp approach features a shared left-turn/through lane and dual eastbound right-turn lanes that are signal controlled. The east leg is a one-way single-lane on-ramp to I-26. No pedestrian crosswalks or signal heads are present.

US 64 (Four Seasons Boulevard / Chimney Rock Road) Corridor

The existing US 64 facility forms a system interchange with I-26 and features a full cloverleaf design with free-flowing entry/exit movements for each facility. No collector / distributor roadways are present for either facility, forcing traffic to merge directly with mainline traffic. Single lane on-ramps and off-ramps are present for all movements. Additional details for individual ramp terminal intersections at the interchange and upstream/downstream of the interchange along US 64 are described in detail below.



- ◆ **US 64 (Four Seasons Boulevard) and SR 1634 (Carolina Village Road)/SR 1749 (Orr's Camp Road)** – This intersection is currently signalized and operates with five signal phases. The eastbound and westbound US 64 approaches feature protected-only left-turn phasing and the minor side street approaches feature single-phase signal operation. The southbound Carolina Village Road approach has a shared left-turn/through lane and an exclusive right-turn lane with an overlap signal phase. The northbound Orr's Camp Road approach features a single shared left-turn/through/right-turn lane. No pedestrian signals or crosswalks are present at this location.
- ◆ **US 64 (Four Seasons Boulevard) and I-26 Southbound Off-Ramp** – The intersection of the US 64 westbound roadway and the I-26 southbound off-ramp is currently signalized and operates with two signal phases. There are three westbound through travel lanes and two southbound off-ramp right-turn lanes. All eastbound US 64 traffic operates with free-flow conditions. No pedestrian signals or crosswalks are present at this location.
- ◆ **US 64 (Chimney Rock Road) and SR 1516 (Francis Road)/SR 1897 (Sugarloaf Road)** – The intersection of US 64 and Francis Road/Sugarloaf Road is currently signalized and operates with six signal phases. The eastbound and westbound approaches on US 64 feature protected-only left-turn phasing and have single left-turn lanes and two through lanes. The eastbound approach features an exclusive right-turn lane with overlap signal phasing, and the westbound approach has a shared through/right-turn lane. The northbound Francis Road approach features an exclusive left-turn lane, shared left-turn/through lane, and an exclusive right-turn lane. The southbound Sugarloaf Road approach has a shared left-turn/through lane and a right-turn lane. Both minor street approaches operate as split signal phases with right-turn signal overlaps. No pedestrian signals or crosswalks are present.

SR 1783 (Upward Road) Interchange

The service interchange of SR 1783 (Upward Road) and I-26 is a traditional diamond configuration. Single lane on-ramps and off-ramps connect to the I-26 mainline. This interchange is currently (as of 2013) undergoing a major reconstruction of the existing overpass and ramp terminals to add capacity to the Upward Road facility through the project study area. Additional details for the ramp terminal intersections are



found in the descriptions below.

- ◆ **SR 1783 (Upward Road) and I-26 Southbound Ramps** – The intersection of Upward Road and the I-26 Southbound Ramps was and will be signalized. Previously, it operated with two signal phases and will be upgraded to three phase operation. For the 2011 base year analysis, the old geometrics included single travel lanes with shared through/turn movements along Upward Road. The southbound off-ramp approach contained single left-turn and right-turn signal-controlled lanes.

The future eastbound Upward Road approach will contain three through travel lanes and an exclusive right-turn lane operating under signal control. The future westbound approach on Upward Road will feature protected+permitted left-turn phasing and will have a single left-turn lane and two through travel lanes. The southbound off-ramp will feature three lanes, one for left-turn/through movements and the other two will be dual right-turn lanes (signalized) that access westbound Upward Road. The south leg of the intersection was and will be a one-way single lane on-ramp to I-26. No pedestrian crosswalks or signal heads were or will be constructed.

- ◆ **SR 1783 (Upward Road) and I-26 Northbound Ramps** – The intersection of Upward Road and the I-26 Northbound Ramps was and will be signalized. Previously, it operated with two signal phases and will be upgraded to three phase operation. For the 2011 base year analysis, the old geometrics included single travel lanes with shared through/turn movements along Upward Road. The northbound off-ramp approach contained single left-turn and right-turn signal-controlled lanes.

The future eastbound Upward Road approach will contain two through travel lanes and dual left-turn lanes operating under protected-only signal control. The future westbound approach on Upward Road will feature a through travel lane and a shared through/right-turn lane. The northbound off-ramp will feature three lanes, one for left-turn only movements, one for left-turn/through movements and the third will be an exclusive right-turn lane (signalized) to access eastbound Upward Road. The north leg of the intersection was a single lane on-ramp to I-26 and will be modified to a two-lane on-ramp (merging downstream to a single lane) for traffic accessing I-26. No pedestrian crosswalks or signal heads were present, but a crosswalk is to be constructed across the northbound off-ramp approach.

US 25 System Interchange

The system interchange of US 25 and I-26 south of Hendersonville is currently a modified three-legged trumpet design, with full free-flow movements for all traffic utilizing the two facilities. Single lane on-ramps and off-ramps connect the two facilities. The US 25 overpass features single travel lanes in each direction for I-26 northbound on and off-ramp traffic.



SR 1142 (Holbert Cove Road) Interchange

The service interchange of SR 1142 (Holbert Cove Road) and I-26 in Polk County is a traditional diamond configuration. Single lane on-ramps and off-ramps connect to the I-26 mainline. Interchange ramp terminals on either end of the Holbert Cove Road underpass (containing a two-lane roadway cross-section) are currently stop-controlled and geometrics are described in detail below.



- ◆ **SR 1142 (Holbert Cove Road) and I-26 Southbound Ramps** – The intersection of Upward Road and the I-26 Southbound Ramps is currently an unsignalized stop-controlled intersection for traffic approaching on the I-26 Southbound off-ramp. Holbert Cove Road approaches feature single travel lanes with shared turn movements. No pedestrian facilities are present.
- ◆ **SR 1142 (Holbert Cove Road) and I-26 Northbound Ramps** – The intersection of Upward Road and the I-26 Northbound Ramps is currently an unsignalized stop-controlled intersection for traffic approaching on the I-26 Northbound off-ramp. Holbert Cove Road approaches feature single travel lanes with shared turn movements. No pedestrian facilities are present.

2.4 Peak Hour Traffic Counts

The *Project Level Traffic Forecast Report: TIP Projects I-4400 / I-4700 / B-5178 / I-5501* document was prepared by the NCDOT Transportation Planning Branch in February 2012. Data collected by NCDOT Traffic Survey Unit personnel for the forecast document and these traffic forecasts developed from the document were used in traffic analysis for this study.

Existing peak hour traffic data for the 2011 base year were taken from several different types of counts, these included:

- ◆ 16 Hour Intersection Turning Movement Counts
- ◆ 48 Hour Vehicle Classification Counts on study area arterials and the I-26 corridor – collected by tubes, radar, and manual methods
- ◆ 48 Hour Interchange Ramp Traffic Volume Counts

Counts were conducted over a four month period between August and November 2011 and included over 80 locations within and adjacent to the I-26 traffic analysis project study area. Refer to the original traffic forecast documentation for additional details. Raw count data was not directly used in the 2011 base year traffic analyses for I-4400/I-4700, 2011 base year volumes that were analyzed in this report are a product of the final traffic forecast data that included daily traffic estimates/directional splits/design hourly volume estimates that were reduced to AM and PM peak hour information. **Figures 3.1 to 3.3 in Appendix A** contain the traffic forecast breakout peak hour traffic volumes, along with additional base year laneage information and LOS results (described in previous and following sections of this report). **Appendix B** contains the traffic forecast output used in this report.

3. CAPACITY ANALYSIS METHODOLOGY

Evaluating traffic operations on suburban arterials and uninterrupted flow freeway facilities is generally done by the determination of level of service (LOS) criteria. The level of service on a freeway segment, arterial corridor, or individual intersection correlates qualitative aspects of traffic flow to quantitative terms. This enables transportation professionals to take the qualitative issues, such as congestion and substandard geometrics, and translate them into measurable quantities, such as operating speeds, flow densities, and vehicular delays. The *2010 Highway Capacity Manual (HCM 2010)* characterizes level of service by letter designations A through F. Level of service A represents ideal low-volume traffic operations, and level of service F represents over-saturated, high-volume traffic operations.

LOS for intersections is determined by average delay per vehicle, while LOS for freeway facilities is primarily determined by vehicular density of a defined freeway segment, merge/diverge area or weaving section. Level of service letter designations and criteria for arterial intersections (seconds of delay per vehicle) and for freeway facilities (average density in passenger cars per mile per lane (pc/mi/ln)) are described in **Table 2**.

The results of this analysis are based on the LOS and delay procedures presented in the *HCM 2010*. To obtain optimized signal timings for the future traffic conditions, the timing optimization software Synchro Professional Version 7.0 was used to evaluate an optimal cycle length and phasing for the projected peak hour traffic volumes. Existing AM and PM peak hour signal timings provided by NCDOT Division 13 and 14 staff were used for the 2011 no-build scenario, and represent coordinated signalized system operation along the project study area's arterial facilities (where applicable). NCDOT Congestion Management Section Capacity Analysis Guidelines were used in developing all other scenario timings for Build scenarios and/or future year analyses.

All freeway analyses, such as basic freeway segments and ramp merges and diverges, were analyzed using the Highway Capacity Software (HCS) 2010 system module FreeVal. FreeVal allows the integration of individual segment analyses to study potential multi-segment operational issues.

To simplify the process of organizing analysis results for all No-Build Alternative and Build Alternative scenarios, an identification scheme was developed for freeway segments and study area intersections. In general, the 84 existing and 94 design year freeway segments analyzed in the HCS FreeVal software package for this study are numbered sequentially 1-47 in the southbound I-26 direction and 48-94 northbound (with several existing segment numbers skipped to account for new segments in the 2040 analyses). Each identification also includes a preceding letter designation for basic freeways (B), diverge ramp areas (D), merge ramp areas (M) and weaving sections (W) in the project study area. There are no other unconventional freeway segments that are not able to be classified by HCM methods. Study area intersections are numbered 1-12 moving from north to south and east to west through the study area, regardless of existing or future traffic control. Any changes to these identification methods for changes in the future 2040 alternative networks are discussed in that section. **Figures 2.1 to 2.3** shows the identification method schematically.

Table 2. Intersection & Freeway Segment Level of Service (LOS) Characteristics

Level of Service Description	Intersection		Freeway	
	Per Vehicle Delay Signal Control	Per Vehicle Delay Stop Control	Basic Freeway Segment Density (pc/mi/ln)	Merge / Diverge / Weaving Area Density (pc/mi/ln)
LOS A ➤ Free flow ➤ Freedom to select desired speed / maneuver is extremely high ➤ General level of comfort and convenience for motorists is excellent	< 10.0 seconds	< 10.0 seconds	0 – 11.0	<= 10.0
LOS B ➤ Stable flow ➤ Other vehicles in the traffic stream become noticeable ➤ Reduction in freedom to maneuver from LOS A	10.0 – 20.0 seconds	10.0 – 15.0 seconds	>11.0 – 18.0	>10.0 – 20.0
LOS C ➤ Stable flow ➤ Maneuverability/operating speed are significantly affected by other vehicles ➤ General level of comfort and convenience declines noticeably	20.0 – 35.0 seconds	15.0 – 25.0 seconds	>18.0 – 26.0	>20.0 – 28.0
LOS D ➤ High density but stable flow ➤ Speed and freedom to maneuver are severely restricted ➤ General level of comfort / convenience is poor ➤ Small increases in traffic will generally cause operational problems	35.0 – 55.0 seconds	25.0 – 35.0 seconds	>26.0 – 35.0	>28.0 – 35.0
LOS E ➤ Unstable flow ➤ Speed reduced to lower but relatively uniform value ➤ Volumes at or near capacity level ➤ Comfort and convenience are extremely poor ➤ Small flow increases/minor traffic disturbances will cause breakdowns	55.0 – 80.0 seconds	35.0 – 50.0 seconds	>35.0 – 45.0	>35.0
LOS F ➤ Forced or breakdown flow ➤ Volumes exceed roadway capacity ➤ Formation of unstable queues ➤ Stoppages for long periods of time because of traffic congestion	> 80.0 seconds	> 50.0 seconds	> 45.0	Demand exceeds capacity

Transportation Research Board, *Highway Capacity Manual*. Washington, D.C.: National Research Council, 2010.

3.1 Freeway Analysis Methodology

The initial procedure for freeway analysis input into the HCS 2010 freeway facility module (FreeVal) involved the segmentation of the existing I-26 freeway into 84 existing and 94 design year segments in the project study area (42 and 47 in each direction, respectively). Segments fall into the following categories – basic freeway segments, merge areas, diverge areas, and weaving segments. Based on existing interchange spacing, no unconventional roadway segments (as defined by HCM methodologies) exist or are projected to occur in the project study area. Several additional segments were added for 2040 future year analyses, as the future Balfour Parkway facility is planned to have a full-movement interchange with I-26 in the project study area corridor.

After segmentation, geometric and traffic flow inputs were entered into the HCS FreeVal software module for each segment. For a basic freeway segment, these inputs (and typical values used in this analysis) include:

- Traffic Volume (From NCDOT Forecast peak hour breakouts – study area entry segment only)
- Peak Hour Factor (Assume 0.90)
- Number of lanes (Two – No-Build, Three – Six Lane, Four – Eight Lane)
- Terrain Type (Assumed to be “Rolling” for this area)
- Base Free Flow Speed (Assumed to be 65 mph for posted 60 mph speed limit and 70 mph for posted 65 mph speed limits along I-26)
- Truck Percentage (Taken from Traffic Forecast – Duals+TTST/2 for peak hour – study area entry segment only)
- Lane Width (12 feet – default)
- Right Shoulder Lateral Clearance (6 feet – default)
- Segment Lengths (as determined by aerial photography between upstream/downstream merge/diverge points)

The FreeVal inputs for merging and diverging areas contain additional input parameters beyond the basic freeway segment information. These parameters, and typical values used in this analysis, include:

- On-Ramp/Off-Ramp Volumes (NCDOT Forecast peak hour breakouts)
- Location of Ramp Relative to Freeway – Left or Right (Right)
- Acceleration/Deceleration Lane Lengths (From aerial photography and field measurement)
- Free Flow Speeds on Ramps (50 mph for cloverleaf/flyover on/off ramps, 45 mph for diamond on/off ramps and 25 mph for loop ramps)
- Truck Percentage (Taken from Traffic Forecast – Duals+TTST/2 for peak hour)
- Presence of Adjacent Upstream/Downstream On/Off-Ramps – Type/Distance from Analyzed Ramp/Adjacent Ramp Volume

The FreeVal inputs for weaving areas contain additional input parameters beyond the basic freeway segment and ramp segment information. These parameters, and typical values used in this analysis, include:

- On-Ramp/Off-Ramp Volumes (From Factored Counts or Forecast)

- Location of Ramp Relative to Freeway – Left or Right (Right)
- Acceleration/Deceleration Lane Lengths (From aerial photography and field measurement)
- Free Flow Speeds on Ramps (25 mph for loop ramps)

After inputs were entered into FreeVal and checked, output data for each segment was collected for the segment density and corresponding LOS. In addition, system-wide information (by freeway direction) from FreeVal was compiled and compared for the study alternatives. Detailed output from FreeVal can be found in **Appendix C**.

3.2 Signalized Intersection Analysis Methodology

Signalized intersection capacity analyses were performed using Synchro Professional Software Version 7.0 for all scenarios. GIS-based roadway centerline information and geo-referenced aerial photography was obtained from NCDOT and NC OneMap to establish a base map for developing the proper spatial orientation of the Synchro roadway network for the four separate roadway corridors that have interchanges with I-26 (NC 146, US 25 (Asheville Highway), US 64, and Upward Road) that are being analyzed for this study. Per direction from NCDOT Congestion Management staff, no analysis of the NC 191 and NC 280 corridors intersecting I-26 were made for this study, as those corridors are currently being analyzed by NCDOT for separate TIP projects.

NCDOT traffic forecast 2011 base year traffic volume data for the AM and PM peak hours was entered into the Synchro networks. Additional signal timing details that comply with NCDOT Congestion Management practices and recommendations were also updated (lost time, no right-turn-on-red, PHF, etc...) Existing coordinated signal timing data (cycle, split, offset) for the AM and PM peak hours was also obtained from NCDOT Division 13 and 14 staff and used for 2011 No-Build Alternative analyses.

2011 Build Alternative analyses and 2040 design year No-Build and Build analyses included updates to Synchro inputs for several inputs including the following:

- Traffic volume updates for each alternative from traffic forecast breakouts
- Reoptimization of cycle lengths/splits/offsets for the 2011 Base Year Build alternatives – holding this data constant between the alternatives for relevant comparison of Build alternative impacts
- Reoptimization of cycle lengths/splits/offsets for 2040 No-Build conditions. Further reoptimization checks for 2040 Build alternatives – keeping values the same between the 6-Lane and 8-Lane alternative scenarios
- Addition of potential future signalized ramp terminal intersections at the Balfour Parkway future interchange with I-26
- Permissible changes in signal phasing in situations where phase orders could improve performance and complied with NCDOT policies/guidelines.

Synchro output, including both LOS and delay results for all analyses, is included in **Appendix D**.

3.3. Unsignalized Intersection Analysis Methodology

Unsignalized intersection capacity analyses were performed using the HCS software module for two-way stop-controlled intersections. There are two existing unsignalized, two-way stop-controlled intersections in the project study area that were included in this analysis – located at the interchange ramp terminals of I-26 and Holbert Cove Road at the southern end of the project study corridor. Inputs into this module include:

- Direction of major street
- Laneage for all approaches
- Traffic Volumes for all approaches
- Median Type (no median)
- Peak Hour Factor (Assume 0.90)
- Truck Percentages (Taken from Traffic Forecast – Duals+TTST/2 for peak hour)
- Approach Grades

Detailed output from HCS can be found in **Appendix E**.

4. DEVELOPMENT OF ALTERNATIVES

The following sections describe the alternatives analyzed in this report. During the project scoping process, it was agreed by all project stakeholders that two Build Alternatives (6 lane and 8 lane widening) would be compared to No-Build scenarios. These alternatives are discussed in detail below.

4.1 No-Build Alternative

The No-Build Alternative assumes that no improvements will be made to the I-26 facility's current capacity or geometrics within the project study area limits, but any other background improvements that are committed to and funded by NCDOT, local municipalities, or private development projects would occur by the 2040 design year. Based on information collected to date for the I-4400/I-4700 project, the following additional improvements are currently anticipated (or approved) in the project study area by the 2040 design year.

- ◆ STIP B-5178 – SR 3431 (Pond Road) and Hominy Creek Bridge Replacement – Project is currently under construction and existing bridges will be widened to accommodate an ultimate eight-lane cross-section of I-26 across Hominy Creek.
- ◆ STIP I-5504 – NC 191 Interchange Improvements – Project is currently under conceptual study by NCDOT and will involve changes to the existing ramp configuration and terminal locations along NC 191. Effects of this project are not specifically studied in the 2040 capacity analyses for STIP I-4400/I-4700.
- ◆ STIP I-5501 – NC 280 Interchange Improvements – Project is in final design to retrofit existing NC 280 overpass bridge to a Diverging Diamond Interchange (DDI). NCDOT has completed traffic capacity analyses for the proposed improvements (summary document found in **Appendix F**). No additional analysis of STIP I-5501 improvements will be done for this study.

- ◆ FS 1214-B Proposed Balfour Parkway – New interchange with I-26 (type as yet to be determined) located approximately one mile north of I-26/US 64 interchange. For the purposes of the capacity analysis for this report, an assumed partial cloverleaf interchange was analyzed for Balfour Parkway, with the Balfour Parkway cross-section being a four-lane divided facility.
- ◆ STIP R-4430 – Upward Road Corridor Improvements – Project is currently under construction/nearing completion (as of July 2013). Upward Road bridge overpass is being widened and interchange ramp terminal improvements (turn lanes, signal phasing) were analyzed in the 2040 design year for all alternatives.

It was assumed that all existing roadway geometrics, laneage, and traffic control would remain consistent with 2011 base year information along all other areas. The only additional improvement assumed in the No-Build Alternative between the 2011 and 2040 analysis years was signal timing optimization for all arterial corridors in the project study area.

4.2 Build Alternative – Widen I-26 to Six Lanes

The proposed Build – 6 Lane Widening alternative would add an additional northbound and southbound travel lane to I-26 from the I-40/I-240/I-26 system interchange to the I-25 system interchange south of Hendersonville. For the purposes of the analysis, it is assumed that these lanes would add/drop at existing ramp connections at both the northern and southern project termini. No specific determination of whether the lanes would be added to the inside or outside (or combinations thereof) of the existing I-26 mainline was made for this analysis. No specific assumptions regarding the need to reconstruct/reconfigure any existing interchange ramp terminal intersections were made for this analysis. In addition, no specific design modifications for existing off-ramp or on-ramp auxiliary lane lengths was made – all existing auxiliary lane lengths were maintained for both Build Alternatives.

Build 6-Lane Alternative laneage is shown on capacity analysis results schematics for the 2011 and 2040 analysis years (detailed in Sections 6 and 7 of this report).

4.3 Build Alternative – Widen I-26 to Eight Lanes

The proposed Build – 8 Lane Widening alternative would add two additional northbound and southbound travel lanes to I-26 along the same project limits as described in Section 4.2, above. It was assumed for the purposes of this analysis that one additional travel lane would tie into the existing project termini interchange ramp auxiliary lanes (as described in Section 4.2, above). The additional proposed travel lane was assumed to originate/terminate in the vicinity of these existing interchange ramp connections. All other assumptions regarding existing study area freeway and interchange ramp terminal geometrics described in Section 4.2 will also be incorporated into the Build – 8 Lane alternative analysis.

The potential for a “hybrid” alternative – where I-26 would be widened to eight travel lanes for a portion of the study area corridor and then widened to six travel lanes for the remaining length of the facility will be discussed in Section 9 of this report and will be based on the future 2040 capacity needs of the facility, based on future anticipated peak hour traffic volumes.

5. 2011 BASE YEAR / 2040 DESIGN YEAR TRAFFIC VOLUME DEVELOPMENT

NCDOT-approved traffic forecast information from the *Project Level Traffic Forecast Report: TIP PROJECTS I-4400 / I-4700 / B-5178 / I-5501*, prepared by NCDOT TPB in February 2012 was used as a basis for developing AM and PM peak hour traffic volume data for the 2011 base year and 2040 design year. The daily traffic forecasts for the I-4400/I-4700 study area from that document are shown in **Appendix B**. Daily traffic flows and design data (DHV and D) were entered into the NCDOT Congestion Management Section peak hour breakout spreadsheets for conversion into peak hour volumes at each study area intersection. Truck percentages from the forecast were utilized in the traffic analysis using the assumption of $(\text{Duals} + \text{TTST} / 2)$ equals peak hour truck percentages.

The peak hour breakout spreadsheet results were converted into individual AM and PM peak hour movements for the existing interchange forms (diamond/cloverleaf/SPUI) in a separate conversion spreadsheet developed by HNTB. Both the peak hour breakout spreadsheets and the interchange conversion spreadsheets are found in **Appendix G**.

All peak hour traffic volumes in the project study area are shown in the freeway segment/intersection LOS results figures in **Appendix A**. These figures, described in detail in the following sections, also schematically show the I-26 freeway system, study area analysis segments, intersections, laneage for each alternative and analysis year.

Traffic flows were balanced between signalized ramp terminals at each interchange, and were balanced (through the FreeVal software data entry) for mainline segments along I-26 based on an entry input volume and subsequent peak hour breakout on-ramp/off-ramp volumes. In this manner, the I-26 system was balanced with a different methodology (and results) than if individual interchange mainline volume breakouts were analyzed in individual HCS freeway segment analyses.

6. 2011 BASE YEAR CAPACITY ANALYSIS RESULTS

This section presents capacity analysis results for the 2011 base year AM and PM peak hours for freeway facilities and intersections within the I-4400/I-4700 project study area.

6.1 2011 Freeway Segment Results

This analysis uses the 2011 base year peak hour traffic volumes and existing freeway geometrics to evaluate existing traffic operations on the I-26 uninterrupted flow facility in the project study area and to determine the density and LOS measures of effectiveness for individual freeway segments, as well as system-wide information. **Figures 2.1 to 2.3** schematically show existing geometrics, intersection traffic control, and speed limits for roadways in the study area, along with the scheme for freeway segment identification numbers. **Appendix C** contains the HCS 2010 FreeVal output files.

6.1.1 2011 No-Build Alternative Scenario Results

Existing peak hour traffic volumes and geometrics were entered into the HCS 2010 FreeVal software module, and **Table 3** provides the results for basic freeway sections, merges, and diverges for northbound and southbound I-26. Most segments along I-26

perform at an acceptable LOS D or better in the AM and PM peak hours, although 16 segments are at or exceeding peak hour capacity (LOS E) in areas north of the NC 280 (Airport Road) interchange. **Figures 3.1 to 3.3** provide a schematic representation of the results for the freeway system in the project study area.

6.1.2 2011 Build – 6 Lane Alternative Scenario Results

The Build – 6 Lane alternative scenario freeway operations results are shown in **Table 4**, and include data that compares the percentage improvement in segment density between the Build – 6 Lane alternative and the No-Build alternative. Results indicate that the Build - 6 Lane alternative would mitigate all No-Build deficiencies in the 2011 base year, even with increased traffic forecast volumes between the two scenarios. Density improvement percentages on segments directly affected by the capacity improvement range from 20-35 percent. **Figures 4.1 to 4.3** provide a schematic representation of the laneage and results for the freeway system in the project study area.

6.1.3 2011 Build – 8 Lane Alternative Scenario Results

The Build – 8 Lane alternative scenario freeway operations results are shown in **Table 5**, and include data that compares the percentage improvement in segment density between the Build – 8 Lane alternative and the No-Build alternative. Similar to the Build – 6 Lane alternative, results indicate that the Build - 8 Lane alternative would mitigate all No-Build deficiencies in the 2011 base year, even with increased traffic forecast volumes between the two scenarios. Density improvement percentages on segments directly affected by the capacity improvement range from 40-55 percent. **Figures 5.1 to 5.3** provide a schematic representation of the laneage and results for the freeway system in the project study area.

NCDOT STIP I-4400/I-4700: I-26 Widening (Buncombe & Henderson Counties)
Purpose and Need Traffic Analysis Technical Memorandum

Table 3. 2011 Base Year No-Build Freeway Operations Summary

I-26 Southbound						Y-Line	I-26 Northbound					
AM Peak Hour		PM Peak Hour		ID#	Type		ID#	Type	AM Peak Hour		PM Peak Hour	
LOS	Density	LOS	Density						LOS	Density	LOS	Density
E	44.8	D	32.4	B1	Basic	NC 191	B94	Basic	D	33.5	E	44.7
E	42.7	E	38.6	D2	Diverge		M93	Merge	E	37.3	E	47.7
D	31.8	C	25.7	B3	Basic		B92	Basic	D	26.4	D	31.6
E	40.8	D	33.1	M4	Merge		D91	Diverge	E	36.8	E	42.0
E	37.9	D	29.5	B5	Basic	NC 146 (Long Shoals Road)	B90	Basic	D	30.6	E	37.8
E	39.3	D	32.6	D6	Diverge		M89	Merge	D	34.2	E	41.0
D	27.7	C	21.9	B7	Basic		B88	Basic	C	22.7	D	27.2
E	38.5	D	30.2	M8	Merge		D87	Diverge	D	30.8	E	36.5
E	36.0	D	26.9	B9	Basic	NC 280 (Airport Road)	B86	Basic	D	27.8	E	35.4
E	38.9	D	30.7	D10	Diverge		M85	Merge	D	30.2	E	37.3
C	22.8	B	17.3	B11	Basic		B84	Basic	B	18.0	C	21.9
D	30.1	C	23.5	M12	Merge		D83	Diverge	C	24.5	D	29.4
D	27.2	C	21.4	B13	Basic	Rest Stop	B82	Basic	C	22.0	D	26.4
D	30.5	C	23.5	D14	Diverge		M81	Merge	C	23.8	D	29.1
C	25.6	C	19.8	B15	Basic		B80	Basic	C	20.4	C	24.8
D	30.1	C	23.0	M16	Merge		D79	Diverge	C	24.2	D	29.0
D	27.1	C	20.9	B17	Basic	US 25 (Asheville Hwy)	B78	Basic	C	21.6	D	26.3
D	31.3	C	23.9	D18	Diverge		M77	Merge	C	24.0	D	29.3
C	20.8	B	15.6	B19	Basic		B76	Basic	B	16.3	C	19.7
C	28.0	C	21.2	M20	Merge		D75	Diverge	C	22.5	C	27.2
C	24.0	B	17.8	B21	Basic	Weigh Station	B74	Basic	C	18.4	C	22.6
C	27.8	C	20.5	D22	Diverge		M73	Merge	B	18.5	C	22.4
C	19.5	B	15.1	B23	Basic		B72	Basic	B	15.6	C	18.7
C	26.2	B	18.0	M24	Merge		D71	Diverge	C	21.2	C	25.7
C	24.0	B	17.8	B25	Basic	US 64	B65	Basic	C	18.4	C	22.6
C	27.6	B	19.8	D31	Diverge		M64	Merge	C	21.1	C	25.9
C	21.2	B	15.9	B32	Basic		B63	Basic	B	15.4	C	19.3
C	21.7	B	14.4	W33	Weave		W62	Weave	B	12.9	B	16.1
C	21.3	B	15.2	B34	Basic	Upward Road (SR 1783)	B61	Basic	B	15.0	C	18.2
C	25.3	B	18.7	M35	Merge		D60	Diverge	B	19.0	C	23.4
C	22.3	B	16.4	B36	Basic		B59	Basic	B	17.0	C	21.1
C	26.2	B	19.0	D37	Diverge		M58	Merge	B	19.1	C	23.7
C	18.1	B	13.2	B38	Basic	US 25 (System)	B57	Basic	B	13.8	B	17.1
C	22.6	B	17.1	M39	Merge		D56	Diverge	B	18.3	C	22.1
C	24.4	B	17.3	D40	Diverge		M55	Merge	B	17.2	C	21.0
B	14.4	A	10.4	B41	Basic		B54	Basic	B	11.2	B	13.5
B	15.7	B	11.5	M42	Merge	Holbert Cove Rd (SR 1142)	D53	Diverge	B	14.2	B	17.1
B	14.3	A	10.5	B43	Basic		B52	Basic	A	11.0	B	13.3
B	16.8	B	12.0	D44	Diverge		M51	Merge	B	12.3	B	14.8
B	13.5	A	9.3	B45	Basic		B50	Basic	A	9.9	B	12.3
B	15.9	B	11.1	M46	Merge	US 25 (System)	D49	Diverge	B	12.0	B	15.0
B	14.3	A	9.9	B47	Basic		B48	Basic	A	10.5	B	13.2

Density = Passenger Cars Equivalent/Mile/Lane

Table 4. 2011 Base Year Build - 6 Lanes Freeway Operations Summary

I-26 Southbound						Y-Line	I-26 Northbound									
AM Peak Hour			PM Peak Hour				ID#	Type	AM Peak Hour			PM Peak Hour				
LOS	Density	% Imprv	LOS	Density	% Imprv				LOS	Density	% Imprv	LOS	Density	% Imprv		
D	29.4	34%	C	22.8	30%	B1	Basic	NC 191 (Brevard Road)	B94	Basic	C	23.5	30%	D	27.7	38%
D	33.0	23%	C	26.5	31%	D2	Diverge		M93	Merge	C	26.0	30%	D	30.5	36%
C	24.8	22%	C	20.0	22%	B3	Basic		B92	Basic	C	20.6	22%	C	23.5	26%
D	30.4	25%	C	24.5	26%	M4	Merge		D91	Diverge	C	26.6	28%	D	30.0	29%
D	27.8	27%	C	22.2	25%	B5	Basic	NC 146 (Long Shoals Road)	B90	Basic	C	23.0	25%	D	26.3	30%
D	29.2	26%	C	23.8	27%	D6	Diverge		M89	Merge	C	25.4	26%	D	29.0	29%
C	22.0	21%	B	17.3	21%	B7	Basic		B88	Basic	B	18.0	21%	C	20.9	23%
D	28.4	26%	C	22.0	27%	M8	Merge		D87	Diverge	C	22.3	28%	C	26.2	28%
C	25.9	28%	C	20.1	25%	B9	Basic	NC 280 (Airport Road)	B86	Basic	C	20.8	25%	C	24.4	31%
D	28.3	27%	C	22.3	27%	D10	Diverge		M85	Merge	C	22.4	26%	C	26.6	29%
B	17.8	22%	B	13.2	24%	B11	Basic		B84	Basic	B	13.8	23%	B	16.6	24%
C	22.1	27%	B	16.5	30%	M12	Merge		D83	Diverge	B	17.1	30%	C	20.2	31%
C	20.5	25%	B	15.5	28%	B13	Basic	Rest Stop	B82	Basic	B	16.2	26%	C	19.2	27%
C	21.3	30%	B	16.2	31%	D14	Diverge		M81	Merge	B	17.0	29%	C	20.3	30%
C	19.3	25%	B	14.4	27%	B15	Basic		B80	Basic	B	15.1	26%	B	18.0	27%
C	21.7	28%	B	16.2	30%	M16	Merge		D79	Diverge	B	16.9	30%	B	20.0	31%
C	20.1	26%	B	15.3	27%	B17	Basic	US 25 (Asheville Highway)	B78	Basic	B	15.9	26%	C	18.9	28%
C	21.8	30%	B	16.6	31%	D18	Diverge		M77	Merge	B	17.1	29%	C	20.4	30%
B	15.6	25%	B	11.4	27%	B19	Basic		B76	Basic	B	12.0	26%	B	14.4	27%
B	20.0	29%	B	14.7	31%	M20	Merge		D75	Diverge	B	15.5	31%	B	18.5	32%
C	18.4	23%	B	12.7	29%	B21	Basic	Weigh Station	B74	Basic	B	13.4	27%	B	16.0	29%
B	19.8	29%	B	13.9	32%	D22	Diverge		M73	Merge	B	13.1	29%	B	15.7	30%
B	15.6	20%	A	10.9	28%	B23	Basic		B72	Basic	B	11.4	27%	B	13.6	27%
B	18.0	31%	B	12.5	31%	M24	Merge		D71	Diverge	B	14.5	32%	B	17.3	33%
B	17.1	29%	B	12.7	29%	B25	Basic	US 64	B65	Basic	B	13.4	27%	B	16.0	29%
B	18.1	34%	B	13.5	32%	D31	Diverge		M64	Merge	B	14.6	31%	B	17.6	32%
B	15.2	28%	B	11.2	30%	B32	Basic		B63	Basic	A	10.9	29%	B	13.7	29%
B	15.4	29%	B	11.1	23%	W33	Weave		W62	Weave	A	9.9	23%	B	12.5	22%
B	14.9	30%	A	10.3	32%	B34	Basic		B61	Basic	A	10.2	32%	B	12.4	32%
B	16.8	34%	B	11.9	36%	M35	Merge		D60	Diverge	B	12.2	36%	B	15.0	36%
B	15.3	31%	A	10.9	34%	B36	Basic	Upward Road (SR 1783)	B59	Basic	B	11.5	32%	B	14.1	33%
B	16.7	36%	B	12.0	37%	D37	Diverge		M58	Merge	B	12.4	35%	B	15.3	35%
B	12.6	30%	A	8.6	35%	B38	Basic		B57	Basic	A	9.3	33%	B	11.4	33%
B	15.3	32%	B	10.8	37%	M39	Merge		D56	Diverge	B	12.1	34%	B	14.7	33%
C	23.9	2%	B	17.0	2%	D40	Diverge	US 25 (System)	M55	Merge	B	16.7	3%	C	20.4	3%
B	14.9	-3%	A	10.1	3%	B41	Basic		B54	Basic	B	11.2	0%	B	13.5	0%
B	16.5	-5%	B	11.1	3%	M42	Merge		D53	Diverge	B	14.2	0%	B	17.1	0%
B	15.0	-5%	A	10.2	3%	B43	Basic		B52	Basic	A	11.0	0%	B	13.3	0%
B	17.1	-2%	B	11.6	3%	D44	Diverge	Holbert Cove Road (SR 1142)	M51	Merge	B	12.3	0%	B	14.8	0%
B	14.0	-4%	A	9.0	3%	B45	Basic		B50	Basic	A	9.9	0%	B	12.3	0%
B	16.7	-5%	B	10.7	4%	M46	Merge		D49	Diverge	B	12.0	0%	B	15.0	0%
B	14.9	-4%	A	9.6	3%	B47	Basic		B48	Basic	A	10.5	0%	B	13.2	0%

Density = Passenger Cars Equivalent/Mile/Lane

% Improvement = Percentage Change in Density Between Build Alternative and No-Build Alternative By Segment

Table 5. 2011 Base Year Build - 8 Lanes Freeway Operations Summary

I-26 Southbound						Y-Line	I-26 Northbound									
AM Peak Hour			PM Peak Hour				ID#	Type	AM Peak Hour			PM Peak Hour				
LOS	Density	% Imprv	LOS	Density	% Imprv				LOS	Density	% Imprv	LOS	Density	% Imprv		
C	21.7	52%	B	17.5	46%	B1	Basic	NC 191 (Brevard Road)	B94	Basic	C	18.1	46%	C	20.8	53%
C	24.1	44%	B	19.3	50%	D2	Diverge		M93	Merge	B	19.5	48%	C	22.6	53%
C	19.1	40%	B	15.4	40%	B3	Basic		B92	Basic	B	16.0	39%	C	18.1	43%
C	22.8	44%	B	18.6	44%	M4	Merge		D91	Diverge	B	19.6	47%	C	22.1	47%
C	21.0	45%	B	17.3	41%	B5	Basic		B90	Basic	B	17.8	42%	C	20.1	47%
C	21.7	45%	B	17.8	45%	D6	Diverge	NC 146 (Long Shoals Road)	M89	Merge	B	19.2	44%	C	21.7	47%
B	17.1	38%	B	13.4	39%	B7	Basic		B88	Basic	B	14.0	38%	B	16.2	40%
C	21.2	45%	B	16.6	45%	M8	Merge		D87	Diverge	B	16.6	46%	B	19.4	47%
C	19.7	45%	B	15.6	42%	B9	Basic		B86	Basic	B	16.1	42%	C	18.8	47%
C	21.2	46%	B	16.8	45%	D10	Diverge	NC 280 (Airport Road)	M85	Merge	B	17.0	44%	B	19.9	47%
B	13.8	39%	A	10.2	41%	B11	Basic		B84	Basic	A	10.7	41%	B	12.8	42%
B	16.6	45%	B	12.5	47%	M12	Merge		D83	Diverge	B	12.6	49%	B	14.9	49%
B	15.7	42%	B	11.9	44%	B13	Basic	Rest Stop	B82	Basic	B	12.4	44%	B	14.7	44%
B	15.7	49%	B	12.0	49%	D14	Diverge		M81	Merge	B	12.8	46%	B	15.2	48%
B	14.7	43%	A	11.0	44%	B15	Basic		B80	Basic	B	11.5	44%	B	13.7	45%
B	16.3	46%	B	12.3	47%	M16	Merge		D79	Diverge	B	12.5	48%	B	14.7	49%
B	15.5	43%	B	11.8	44%	B17	Basic	US 25 (Asheville Highway)	B78	Basic	B	12.3	43%	B	14.5	45%
B	16.3	48%	B	12.4	48%	D18	Diverge		M77	Merge	B	12.9	46%	B	15.4	47%
B	12.0	42%	A	8.8	44%	B19	Basic		B76	Basic	A	9.3	43%	A	11.0	44%
B	15.0	46%	B	11.1	48%	M20	Merge		D75	Diverge	B	11.4	49%	B	13.6	50%
B	13.2	45%	A	9.8	45%	B21	Basic		B74	Basic	A	10.3	44%	B	12.2	46%
B	13.7	51%	B	10.2	50%	D22	Diverge	Weigh Station	M73	Merge	A	9.9	46%	B	11.8	47%
B	11.2	43%	A	8.3	45%	B23	Basic		B72	Basic	A	8.8	44%	A	10.4	44%
B	12.7	52%	A	9.4	48%	M24	Merge		D71	Diverge	B	10.7	50%	B	12.7	51%
B	13.1	45%	A	9.8	45%	B25	Basic	US 64	B65	Basic	A	10.3	44%	B	12.2	46%
B	13.4	51%	A	10.0	49%	D31	Diverge		M64	Merge	B	11.0	48%	B	13.1	49%
B	11.5	46%	A	8.5	47%	B32	Basic		B63	Basic	A	8.3	46%	A	10.4	46%
B	12.4	43%	A	9.0	38%	W33	Weave		W62	Weave	A	8.0	38%	B	10.0	38%
B	11.3	47%	A	7.8	49%	B34	Basic		B61	Basic	A	7.7	49%	A	9.4	48%
B	12.4	51%	A	8.8	53%	M35	Merge		D60	Diverge	A	8.9	53%	B	10.9	53%
B	11.6	48%	A	8.3	49%	B36	Basic	Upward Road (SR 1783)	B59	Basic	A	8.7	49%	A	10.7	49%
B	12.2	53%	A	8.7	54%	D37	Diverge		M58	Merge	A	9.2	52%	B	11.3	52%
A	9.5	48%	A	6.5	51%	B38	Basic		B57	Basic	A	7.0	49%	A	8.6	50%
B	11.2	50%	A	7.9	54%	M39	Merge	US 25 (System)	D56	Diverge	A	8.2	55%	A	9.9	55%
C	24.0	2%	B	17.0	2%	D40	Diverge		M55	Merge	B	16.7	3%	C	20.4	3%
A	10.0	31%	A	10.1	3%	B41	Basic		B54	Basic	B	11.2	0%	B	13.5	0%
B	16.7	-6%	B	11.2	3%	M42	Merge		D53	Diverge	B	14.2	0%	B	17.1	0%
B	15.1	-6%	A	10.2	3%	B43	Basic		B52	Basic	A	11.0	0%	B	13.3	0%
B	17.3	-3%	B	11.7	3%	D44	Diverge	Holbert Cove Road (SR 1142)	M51	Merge	B	12.3	0%	B	14.8	0%
B	14.1	-4%	A	9.0	3%	B45	Basic		B50	Basic	A	9.9	0%	B	12.3	0%
B	16.9	-6%	B	10.7	4%	M46	Merge		D49	Diverge	B	12.0	0%	B	15.0	0%
B	15.0	-5%	A	9.7	2%	B47	Basic	B48	Basic	A	10.5	0%	B	13.2	0%	

Density = Passenger Cars Equivalent/Mile/Lane
% Improvement = Percentage Change in Density Between Build Alternative and No-Build Alternative By Segment

6.2 2011 Base Year Intersection Capacity Analysis Results

The following sections provide descriptions and tabular results for intersection capacity analyses for all project study area intersections. LOS results and additional details for these scenarios are found in the raw Synchro output sheets in **Appendix D**. The project study area contains two unsignalized intersections – these capacity analysis output sheets are found in **Appendix E**. A tabular results summary for all alternative scenarios is found in **Table 6** on the following pages.

6.2.1 2011 No-Build Alternative Scenario Results

For the 2011 No-Build alternative AM and PM peak hour scenarios, the existing signalized ramp terminal intersections along the I-26 study area corridor generally operate at or have movements that operate at adequate levels of service in the AM and PM peak hours. Existing signal timing data provided by NCDOT was used in all analyses. Several notable results include:

- ◆ The US 25 (Asheville Highway) ramp terminal intersections currently experience deficient overall LOS in at least one peak hour at each intersection, primarily due to high vehicular delays for left-turn movements.
- ◆ The US 64 and Francis Road/Sugarloaf Road intersection experiences a LOS E for the AM peak hour, primarily due to limited capacity for US 64 left-turn movements and side street traffic flows.
- ◆ The Upward Road ramp terminal intersections provide adequate operations for the overall intersections, even with the older two-lane bridge geometrics. Assumptions for coordinated signal timings were necessary at these locations, as no data was available for older signal control parameters.

Traffic volumes, geometrics, and overall intersection LOS results are also found in **Figures 3.1 to 3.3** for the study area intersections in the 2011 No-Build alternative scenario.

6.2.2 2011 Build – 6 Lane Alternative Scenario Results

For the 2011 Build – 6 Lane alternative AM and PM peak hour scenarios, it was assumed that all existing signalized intersections in the project study area would be reoptimized, to reflect anticipated traffic volume changes that were included in the I-4400/I-4700 traffic forecast data. These changes had a positive effect on operations at the US 25 (Asheville Highway) ramp terminal intersections, though the I-26 Southbound Ramp intersection still is projected to operate at a LOS F. Signal timing adjustments also allowed the US 64 and Francis Road/Sugarloaf Road intersection to improve from a LOS E to a LOS D in the 2011 AM peak hour. No other intersections would be expected to operate at an overall LOS E or LOS F in the 2011 base year in this alternative.

Traffic volumes, geometrics, and overall intersection LOS results are also found in **Figures 4.1 to 4.3** for the study area intersections in the 2011 Build – 6 Lane alternative scenario.

Table 6. 2011 AM & (PM) Peak Hour No-Build/Build Intersection Capacity Analysis Results Summary

Intersection (ID#)	2011 No-Build Alternative						2011 – Build 6 Lanes Alternative						2011 – Build 8 Lanes Alternative											
	LOS	Delay	Approach	LOS	Delay	Movmnt	LOS	Delay	Approach	LOS	Delay	Movmnt	LOS	Delay	Approach	LOS	Delay	Approach	LOS	Delay	Movmnt	LOS	Delay	
I-26 Ramps & NC 146 (Long Shoals Rd) SPU1 (1)	C (C)	21.8 (21.5)	EB	B (C)	19.8 (25.2)	EB LT	D (D)	37.4 (42.5)	C (C)	30.2 (30.0)	EB	C (C)	22.4 (23.8)	EB LT	D (D)	48.6 (53.4)	C (C)	32.0 (32.0)	EB	C (C)	22.7 (24.7)	EB LT	D (E)	49.7 (56.3)
						EB TH	C (C)	21.9 (27.6)						EB TH	C (C)	21.2 (20.1)						EB TH	C (C)	21.1 (20.1)
						EB RT	A (A)	0.2 (0.2)						EB RT	A (A)	0.2 (0.2)						EB RT	A (A)	0.2 (0.2)
			WB	C (B)	20.6 (18.2)	WB LT	D (D)	48.2 (43.2)			WB LT	D (D)	43.3 (46.0)	WB LT	D (D)	43.1 (45.6)								
						WB TH	B (C)	19.4 (21.4)			WB TH	B (B)	14.7 (14.4)	WB TH	B (B)	14.8 (15.3)								
						WB RT	A (A)	1.0 (1.0)			WB RT	A (A)	1.4 (1.2)	WB RT	A (A)	1.4 (1.3)								
			NB	A (A)	8.8 (7.4)	NB LT	C (C)	26.3 (26.4)			NB LT	C (C)	33.4 (32.5)	NB LT	C (C)	33.6 (32.7)								
						NB RT	A (A)	0.4 (0.6)			NB RT	A (A)	0.4 (0.6)	NB RT	A (A)	0.4 (0.5)								
						SB	D (D)	35.6 (33.0)			SB LT	D (D)	36.7 (36.3)	SB LT	F (F)	82.6 (83.0)			SB LT	F (F)	90.5 (91.6)			
			SB	D (D)	35.6 (33.0)	SB RT	C (C)	31.8 (29.3)			SB RT	D (D)	47.0 (39.4)	SB RT	D (D)	50.1 (40.7)								
						WB	C (F)	23.5 (180.5)			WB LT	E (E)	62.8 (68.8)	WB	C (F)	29.2 (81.6)			WB LT	F (D)	87.9 (41.3)			
						NB	A (F)	8.7 (85.0)			WB RT	A (F)	8.3 (214.7)	WB RT	B (F)	11.2 (87.6)			WB RT	B (F)	11.3 (91.3)			
I-26 NB Ramps & US 25 (Asheville Hwy) (2)	D (E)	47.1 (77.6)	NB	A (F)	8.7 (85.0)	NB LT	C (F)	24.5 (232.9)	C (D)	22.4 (40.6)	NB	A (B)	7.2 (18.6)	NB LT	B (D)	17.7 (49.8)	C (D)	22.5 (43.2)	NB	A (C)	7.7 (21.0)	NB LT	B (E)	19.2 (56.3)
						NB TH	A (A)	0.1 (2.7)						NB TH	A (A)	1.4 (0.7)						NB TH	A (A)	1.4 (0.7)
						SB	F (C)	89.9 (21.9)						SB TH	F (C)	103.7 (26.1)						SB TH	D (E)	39.7 (67.2)
I-26 SB Ramps & US 25 (Asheville Hwy) (3)	F (D)	162.9 (50.2)	EB	F (F)	608.9 (111.5)	EB LT	E (F)	67.7 (84.0)	F (D)	97.6 (53.2)	EB	F (E)	135.9 (77.6)	EB LT	C (D)	31.7 (54.9)	F (E)	102.7 (57.5)	EB	F (F)	141.3 (84.5)	EB LT	C (E)	32.2 (58.4)
						EB RT	F (F)	787.4 (123.0)						EB RT	F (F)	176.5 (88.8)						EB RT	F (F)	185.1 (97.7)
						NB	D (D)	42.0 (47.8)						NB TH	D (D)	46.6 (51.9)						NB TH	F (E)	127.4 (63.0)
US 64 & Francis Road / Sugarloaf Rd (6)	E (D)	65.2 (41.1)	WB	F (D)	109.9 (36.0)	WB LT	E (F)	72.6 (93.4)	D (D)	41.6 (36.4)	WB	D (C)	48.2 (30.5)	WB LT	F (F)	98.3 (105.2)	D (D)	42.3 (36.7)	WB	D (C)	51.0 (30.4)	WB LT	F (F)	93.0 (101.5)
						WB THRT	F (C)	111.6 (33.6)						WB THRT	D (C)	46.1 (27.7)						WB THRT	D (C)	49.3 (28.0)
						NB	E (E)	55.2 (76.0)						NB LT	E (F)	60.1 (83.6)						NB LT	F (F)	83.3 (105.7)
I-26 SB Ramps & US 64 WB (7)	B (A)	13.9 (9.1)	SB	E (F)	64.6 (85.2)	NB RT	C (D)	30.4 (46.2)	B (B)	10.8 (10.1)	SB	E (E)	66.7 (65.3)	NB RT	D (D)	41.9 (49.9)	B (B)	11.2 (10.5)	SB	E (E)	65.5 (77.7)	NB RT	D (D)	41.8 (49.5)
						SB LTTH	E (F)	56.6 (81.7)						SB LTTH	E (E)	64.6 (77.3)						SB LTTH	E (E)	64.6 (77.3)
						SB RT	D (D)	44.0 (52.9)						SB RT	E (E)	67.3 (62.2)						SB RT	E (E)	65.4 (60.4)
US 64 & Carolina Village Rd / Orr's Camp Rd (8)	D (D)	49.8 (47.5)	EB	C (D)	26.7 (50.0)	EB TH	A (A)	0.2 (1.1)	C (D)	33.1 (40.6)	EB	C (D)	29.7 (42.5)	EB TH	A (A)	0.2 (0.2)	C (D)	33.5 (40.8)	EB	C (D)	29.4 (43.0)	EB TH	A (A)	0.2 (0.2)
						EB RT	A (A)	0.1 (0.1)						EB RT	A (A)	0.1 (0.1)						EB RT	A (A)	0.1 (0.1)
						WB	B (A)	16.3 (5.2)						WB TH	B (A)	16.3 (5.2)						WB	A (A)	7.6 (8.7)
			WB	E (C)	57.2 (34.2)	WB THRT	E (F)	72.0 (97.7)			WB THRT	F (C)	111.6 (33.6)	WB THRT	D (C)	46.1 (27.7)			WB THRT	D (C)	49.3 (28.0)			
						WB TH	E (C)	58.9 (31.1)			NB LTTH	E (F)	59.5 (82.1)	WB TH	C (B)	21.8 (18.1)			WB TH	C (B)	22.2 (18.2)			
						WB RT	A (B)	8.3 (15.2)			NB RT	C (D)	30.4 (46.2)	WB RT	A (A)	5.9 (9.3)			WB RT	A (A)	6.0 (9.3)			
			NB	F (F)	133.7 (109.4)	NB LTR	F (F)	133.7 (109.4)			NB RT	C (D)	30.4 (46.2)	NB LTR	F (F)	104.8 (120.3)			NB LTR	F (F)	104.8 (120.3)			
						SB	E (E)	77.8 (66.7)			SB LTTH	F (F)	107.1 (81.9)	SB	E (E)	68.9 (71.8)			SB LTTH	F (F)	88.4 (89.4)			
						SB RT	C (C)	26.4 (34.6)			SB RT	C (C)	26.4 (34.6)	SB RT	C (C)	34.9 (34.9)			SB RT	C (C)	34.6 (34.7)			

Delay Measured In Seconds Per Vehicle

BOLD/ITALIC = Intersection/Approach/Movement that has Operational Deficiencies (LOS E or F)

Table 6 Cont'd. 2011 AM & (PM) Peak Hour No-Build/Build Intersection Capacity Analysis Results Summary

Intersection (ID#)	2011 No-Build Alternative						2011 – Build 6 Lanes Alternative						2011 – Build 8 Lanes Alternative											
	LOS	Delay	Approach	LOS	Delay	Movmnt	LOS	Delay	Approach	LOS	Delay	Movmnt	LOS	Delay	Approach	LOS	Delay	Movmnt	LOS	Delay				
I-26 NB Ramps & Upward Road (9)	C (D)	22.3 (35.9)	EB	B (C)	19.3 (28.7)	EB LTTH	B (C)	19.3 (28.7)	C (D)	22.7 (38.8)	EB	C (C)	20.3 (34.4)	EB LTTH	C (C)	20.3 (34.4)	C (D)	22.8 (39.7)	EB	C (D)	21.9 (38.6)	EB LTTH	C (D)	21.9 (38.6)
			WB	A (A)	4.5 (3.2)	WB TH	A (A)	4.8 (3.4)			WB	A (A)	4.4 (3.2)	WB TH	A (A)	4.6 (3.3)			WB	A (A)	4.4 (3.2)	WB TH	A (A)	4.6 (3.3)
				WB RT	A (A)	3.8 (2.9)	WB RT	A (A)				3.8 (2.9)	WB RT	A (A)	3.8 (2.9)									
			NB	E (F)	59.0 (97.1)	NB LT	E (F)	66.5 (119.7)			NB	E (F)	58.3 (96.0)	NB LT	E (F)	65.0 (117.2)			NB	E (F)	56.4 (91.1)	NB LT	E (F)	62.4 (110.0)
						NB RT	D (D)	38.6 (50.1)						NB RT	D (D)	37.7 (47.2)						NB RT	D (D)	37.3 (46.0)
I-26 SB Ramps & Upward Road (10)	C (C)	31.4 (22.7)	EB	B (B)	13.5 (14.1)	EB TH	B (B)	14.6 (15.6)	D (C)	35.5 (24.2)	EB	B (B)	13.4 (15.1)	EB TH	B (B)	14.5 (16.8)	C (C)	34.9 (24.9)	EB	B (B)	13.6 (15.5)	EB TH	B (B)	14.7 (17.3)
						EB RT	B (A)	10.5 (9.2)						EB RT	B (A)	10.5 (9.3)						EB RT	B (A)	10.4 (9.3)
			WB	C (B)	34.9 (19.2)	WB LTTH	C (B)	34.9 (19.2)			WB	C (B)	31.6 (17.8)	WB LTTH	C (B)	31.6 (17.8)			WB	C (B)	22.4 (17.0)	WB LTTH	C (B)	22.4 (17.0)
			SB	D (D)	53.0 (43.7)	SB LT	C (C)	24.4 (26.8)			SB	E (D)	68.9 (48.4)	SB LT	C (C)	24.3 (26.4)			SB	E (D)	74.5 (50.2)	SB LT	C (C)	24.5 (26.5)
						SB RT	E (D)	60.8 (49.8)						SB RT	E (E)	79.6 (55.4)						SB RT	F (E)	86.9 (57.8)
I-26 NB Ramps & Holbert Cove Road (11)	N/A	N/A	EB	N/A	N/A	EB LT	A (A)	7.6 (7.6)	N/A	N/A	EB	N/A	N/A	EB LT	A (A)	7.6 (7.6)	N/A	N/A	EB	N/A	N/A	EB LT	A (A)	7.6 (7.6)
			NB	B (B)	11.4 (11.4)	NB LT	B (B)	12.6 (12.2)			NB	B (B)	11.4 (11.4)	NB LT	B (B)	12.6 (12.2)			NB	B (B)	11.4 (11.4)	NB LT	B (B)	12.6 (12.2)
						NB RT	A (A)	8.7 (8.7)						NB RT	A (A)	8.7 (8.7)						NB RT	A (A)	8.7 (8.7)
I-26 SB Ramps & Holbert Cove Road (12)	N/A	N/A	WB	N/A	N/A	WB LT	A (A)	7.9 (7.7)	N/A	N/A	WB	N/A	N/A	WB LT	A (A)	7.9 (7.7)	N/A	N/A	WB	N/A	N/A	WB LT	A (A)	7.9 (7.7)
			SB	A (A)	9.8 (9.9)	SB LT	B (B)	11.2 (11.0)			SB	A (A)	9.8 (9.9)	SB LT	B (B)	11.2 (11.0)			SB	A (A)	9.8 (9.9)	SB LT	B (B)	11.2 (11.0)
						SB RT	A (A)	9.1 (9.6)						SB RT	A (A)	9.1 (9.6)						SB RT	A (A)	9.1 (9.6)

N/A – LOS/Delay Not Calculated for Overall Unsignalized Intersection or Non-Stop-Controlled Approaches
Delay Measured In Seconds Per Vehicle
BOLD/ITALIC = Intersection/Approach/Movement that has Operational Deficiencies (LOS E or F)

6.2.3 2011 Build – 8 Lane Alternative Scenario Results

In the 2011 Build – 8 Lane alternative AM and PM peak hour scenarios, it was assumed that all signal timings that were optimized in the 2011 Build – 6 Lane scenario would be held constant, to provide a meaningful comparison between the two Build alternatives. As shown in Table 6, the additional or redistributed traffic volumes projected in the project-level traffic forecast have small negative impacts on study area intersection operations. In most cases, overall intersection delays increase by less than five seconds between the 6-Lane and 8-Lane alternative scenarios. In one case, at the intersection of the I-26 Southbound ramps and US 25 (Asheville Highway), the overall intersection LOS drops from a LOS D in the 6-Lane alternative scenario to a LOS E in the 8-Lane alternative scenario in the PM peak.

Traffic volumes, geometrics, and overall intersection LOS results are also found in **Figures 5.1 to 5.3** for the study area intersections in the 2011 Build – 6 Lane alternative scenario.

7. 2040 DESIGN YEAR CAPACITY ANALYSIS RESULTS

This section presents capacity analysis results for the 2040 design year AM and PM peak hours for freeway facilities and intersections within the I-4400/I-4700 project study area.

7.1 2040 Freeway Segment Analysis Results

This analysis incorporates the 2040 design year approved traffic forecast daily traffic volumes converted to peak hour traffic volumes and existing freeway geometrics (with several modifications) to evaluate future traffic operations on the I-26 facility in the project study area. These inputs determine the density and LOS measures of effectiveness for individual freeway segments. **Figures 6.1** and **6.2** schematically show proposed geometric changes and intersection traffic control that are expected to occur by the 2040 analysis year in the I-4400/I-4700 study area. **Figures 6.1** and **6.2** also illustrate the scheme for any changes to freeway segment identification numbers. The following are the anticipated changes to the study area freeway network between the 2011 and 2040 analysis years, regardless of alternative scenario analyzed.

Balfour Parkway Interchange

FS 1214B – Balfour Parkway is currently under study by NCDOT. At the time of this analysis, no information regarding a potential interchange concept is available from FS 1214B, though a full movement interchange with I-26 was part of the I-4400/I-4700 traffic forecast. To analyze potential impacts to freeway operations from the proposed Balfour Parkway project, some initial assumptions of an interchange form that could reasonably accommodate future 2040 peak hour traffic volumes was made – no additional analyses or quantification of impacts of this proposed form (a partial cloverleaf interchange) were made as part of the I-4400/I-4700 NEPA process.

A partial cloverleaf, with loop ramps in the northeast and southwest quadrants, was analyzed in the FreeVal methodology by inserting diverge and merge segments into the existing I-26 freeway network configuration. There would be two successive diverge segments (for each direction of Balfour Parkway traffic) along I-26, followed by a single merge segment in this concept. Additional assumptions were made for diverge lane deceleration lengths (450 feet for each diverge) and acceleration lane lengths for each merge (1,000 feet). All ramp merges and

diverges were assumed to be a single lane, widening for auxiliary turn lanes at the signalized ramp terminals.

As previously mentioned, additional study area network changes to interchange ramps and signalized ramp terminal intersections are planned to occur at the NC 191 and NC 280 interchanges. These changes were not specifically analyzed in this report, per direction from NCDOT. **Appendix C** contains the HCS 2010 FreeVal output files. Individual alternative scenario results are highlighted below.

7.1.1 2040 No-Build Alternative Scenario Results

2040 peak hour traffic volumes and geometrics were entered into the HCS 2010 FreeVal software module, and **Table 7** provides the results for basic freeway sections, merges, and diverges for northbound and southbound I-26. The increase in projected traffic volumes between 2011 and 2040 along the corridor causes multiple segments to experience deficient (LOS E or F) results in one or both peak hours. AM peak hour southbound and PM peak hour northbound, in particular, experience capacity issues for a majority of the I-26 project study area. **Figures 7.1 to 7.4** provide a schematic representation of the results for the freeway system in the project study area.

7.1.2 2040 Build – 6 Lane Alternative Scenario Results

The Build – 6 Lane alternative scenario freeway operations results for the 2040 design year are shown in **Table 8**, and include data that compares the percentage improvement in segment density between the Build – 6 Lane alternative and the No-Build alternative. Results indicate that the Build - 6 Lane alternative would mitigate some No-Build deficiencies in the 2040 design year, even with increased traffic forecast volumes between the two scenarios. Operational issues would still exist for 12 of 47 segments for southbound I-26 in the AM peak hour and 7 of 47 segments along northbound I-26 in the PM peak hour. Most of these segments are located north of the NC 280 interchange. There is also a potential capacity issue in the area at the US 25 system interchange southbound diverge and northbound merge ramps – caused by the lane drop/add in these areas.

Density improvement percentages on segments directly affected by the capacity improvement range from 7-35 percent, with negative improvements reported at the US 25 system interchange area described in the paragraph above. **Figures 8.1 to 8.4** provide a schematic representation of the laneage and results for the freeway system in the project study area.

7.1.3 2040 Build – 8 Lane Alternative Scenario Results

The Build – 8 Lane alternative scenario freeway operations results for the 2040 design year are shown in **Table 9**, and include data that compares the percentage improvement in segment density between the Build – 8 Lane alternative and the No-Build alternative. Results indicate that the Build - 8 Lane alternative would mitigate almost all No-Build deficiencies in the 2040 design year, even with increased traffic forecast volumes between the two scenarios. The only projected deficient freeway segments for the Build – 8 Lane alternative are located at the southern US 25 system interchange project terminus. Similar to the issues found in the 2040 Build – 6 Lane alternative analysis, FreeVal results indicate there are potential issues in the area where the 8 lane facility would transition from the existing four-lane cross-section.

Density improvement percentages on segments directly affected by the Build 8-Lane capacity improvement range from 20-50 percent. **Figures 9.1 to 9.4** provide a schematic representation of the laneage and results for the freeway system in the project study area.

NCDOT STIP I-4400/I-4700: I-26 Widening (Buncombe & Henderson Counties)
Purpose and Need Traffic Analysis Technical Memorandum

Table 7. 2040 Design Year No-Build Alternative - Freeway Operations Summary

I-26 Southbound						Y-Line	I-26 Northbound					
AM Peak Hour		PM Peak Hour		ID#	Type		ID#	Type	AM Peak Hour		PM Peak Hour	
LOS	Density	LOS	Density						LOS	Density	LOS	Density
E	42.7	E	41.4	B1	Basic	NC 191 (Brevard Road)	B94	Basic	E	39.5	E	44.5
F	47.4	E	44.3	D2	Diverge		M93	Merge	E	43.0	E	46.3
F	53.1	D	32.4	B3	Basic		B92	Basic	D	31.2	F	49.2
E	45.8	E	45.8	M4	Merge		D91	Diverge	E	44.5	E	42.5
E	44.5	E	43.2	B5	Basic	NC 146 (Long Shoals Road)	B90	Basic	E	41.4	E	44.7
E	43.3	E	41.4	D6	Diverge		M89	Merge	E	43.9	E	45.0
D	28.8	D	26.8	B7	Basic		B88	Basic	C	25.9	F	65.5
E	42.4	E	38.2	M8	Merge		D87	Diverge	E	35.5	E	42.8
E	41.1	E	35.2	B9	Basic	NC 280 (Airport Road)	B86	Basic	D	33.7	F	45.1
E	42.0	E	37.2	D10	Diverge		M85	Merge	E	35.8	E	43.5
C	25.3	C	22.1	B11	Basic		B84	Basic	C	21.3	D	27.3
E	41.8	E	36.9	M12	Merge		D83	Diverge	E	35.2	E	43.7
E	41.3	D	33.8	B13	Basic	Rest Stop	B82	Basic	D	32.4	F	45.4
E	40.1	D	34.9	D14	Diverge		M81	Merge	E	35.1	E	47.0
E	38.7	D	31.2	B15	Basic		B80	Basic	D	29.9	E	37.2
E	44.6	E	36.4	M16	Merge		D79	Diverge	D	34.0	E	42.0
E	42.6	D	33.8	B17	Basic	US 25 (Asheville Hwy)	B78	Basic	D	32.4	F	45.4
E	42.4	E	36.1	D18	Diverge		M77	Merge	E	35.3	E	45.1
D	26.4	C	22.9	B19	Basic		B76	Basic	C	22.0	D	28.5
E	38.1	D	32.8	M20	Merge		D75	Diverge	D	31.6	E	40.2
D	34.7	D	28.3	B21	Basic	Weigh Station	B74	Basic	D	27.1	E	37.8
E	36.4	D	30.8	D22	Diverge		M73	Merge	C	25.8	E	38.3
C	25.6	C	21.7	B23	Basic		B72	Basic	C	21.0	D	27.5
E	36.6	C	26.9	M24	Merge		D71	Diverge	D	29.8	E	38.2
E	35.7	D	28.3	B25	Basic	Balfour Parkway	B70	Basic	D	28.4	E	37.8
E	36.2	D	30.2	D26	Diverge		M69	Merge	D	31.3	E	38.0
D	34.2	D	32.9	D27	Diverge		B68	Basic	C	20.3	C	25.0
C	24.3	C	19.7	B28	Basic		D67	Diverge	D	31.9	D	34.8
E	36.3	D	30.1	M29	Merge	US 64	D66	Diverge	D	30.5	E	37.5
E	35.8	D	27.5	B30	Basic		B65	Basic	D	26.4	E	37.9
E	36.4	D	28.9	D31	Diverge		M64	Merge	D	29.9	E	40.5
D	30.1	C	24.0	B32	Basic		B63	Basic	C	22.1	D	30.2
D	30.4	C	22.3	W33	Weave	Upward Road (SR 1783)	W62	Weave	B	19.5	D	29.0
D	30.8	C	24.1	B34	Basic		B61	Basic	C	22.0	D	29.5
E	39.5	D	30.5	M35	Merge		D60	Diverge	C	27.8	E	37.2
E	36.8	D	27.1	B36	Basic		B59	Basic	C	26.0	E	36.9
E	37.5	D	29.8	D37	Diverge	US 25 (System)	M58	Merge	D	28.9	E	38.1
D	27.4	C	21.6	B38	Basic		B57	Basic	C	20.7	D	28.2
E	39.8	D	32.4	M39	Merge		D56	Diverge	D	31.0	E	38.8
E	39.3	D	31.2	D40	Diverge		M55	Merge	D	30.3	E	39.4
C	25.2	C	20.6	B41	Basic	Holbert Cove Rd (SR 1142)	B54	Basic	C	20.2	C	24.5
C	27.7	C	23.1	M42	Merge		D53	Diverge	C	25.5	D	28.3
C	25.2	C	20.8	B43	Basic		B52	Basic	C	19.9	C	25.2
D	28.5	C	23.6	D44	Diverge		M51	Merge	C	22.5	C	28.0
C	23.4	C	19.2	B45	Basic	SR 1142	B50	Basic	C	18.5	C	23.5
C	27.9	C	23.1	M46	Merge		D49	Diverge	C	22.2	D	28.5
C	25.2	C	20.5	B47	Basic		B48	Basic	C	21.0	C	25.2

Density = Passenger Cars Equivalent/Mile/Lane

Table 8. 2040 Design Year Build - 6 Lanes Alternative - Freeway Operations Summary

I-26 Southbound						Y-Line	I-26 Northbound									
AM Peak Hour			PM Peak Hour				ID#	Type	AM Peak Hour			PM Peak Hour				
LOS	Density	% Imprv	LOS	Density	% Imprv				LOS	Density	% Imprv	LOS	Density	% Imprv		
E	39.9	7%	D	28.7	31%	B1	Basic	NC 191 (Brevard Road)	B94	Basic	D	28.5	28%	E	37.8	15%
E	37.8	20%	D	32.2	27%	D2	Diverge		M93	Merge	D	31.3	27%	E	39.2	15%
D	32.5	39%	C	25.0	23%	B3	Basic		B92	Basic	C	24.9	20%	D	31.1	37%
E	40.6	11%	D	32.1	30%	M4	Merge		D91	Diverge	D	33.0	26%	E	39.4	7%
E	40.6	9%	D	29.6	31%	B5	Basic	NC 146 (Long Shoals Road)	B90	Basic	D	29.5	29%	E	38.7	13%
E	38.7	11%	D	30.9	25%	D6	Diverge		M89	Merge	D	32.2	27%	E	40.1	11%
D	28.6	1%	C	22.0	18%	B7	Basic		B88	Basic	C	22.0	15%	D	27.6	58%
E	38.4	9%	D	29.6	23%	M8	Merge		D87	Diverge	D	28.6	19%	D	35.0	18%
E	37.8	8%	D	27.1	23%	B9	Basic	NC 280 (Airport Road)	B86	Basic	D	26.9	20%	E	35.6	21%
E	37.7	10%	D	29.3	21%	D10	Diverge		M85	Merge	D	29.2	18%	E	37.5	14%
C	24.6	3%	C	19.0	14%	B11	Basic		B84	Basic	C	18.9	11%	C	23.7	13%
E	35.1	16%	C	27.3	26%	M12	Merge		D83	Diverge	C	26.8	24%	D	32.8	25%
D	33.6	19%	C	25.1	26%	B13	Basic	Rest Stop	B82	Basic	C	24.9	23%	D	31.8	30%
D	33.7	16%	C	26.4	24%	D14	Diverge		M81	Merge	C	26.7	24%	D	33.7	28%
D	31.1	20%	C	23.4	25%	B15	Basic		B80	Basic	C	23.2	22%	D	29.8	20%
E	35.1	21%	C	26.8	26%	M16	Merge		D79	Diverge	C	26.0	24%	D	31.9	24%
D	33.6	21%	C	24.8	27%	B17	Basic	US 25 (Asheville Highway)	B78	Basic	C	24.6	24%	D	31.8	30%
D	34.6	18%	C	26.8	26%	D18	Diverge		M77	Merge	C	27.0	24%	D	34.1	24%
C	24.5	7%	C	19.1	17%	B19	Basic		B76	Basic	C	19.0	14%	C	23.4	18%
D	32.3	15%	C	25.4	23%	M20	Merge		D75	Diverge	C	24.9	21%	D	30.5	24%
D	29.1	16%	C	21.8	23%	B21	Basic	Weigh Station	B74	Basic	C	21.7	20%	D	27.9	26%
D	30.3	17%	C	23.5	24%	D22	Diverge		M73	Merge	C	21.1	18%	C	26.3	31%
C	22.9	11%	B	18.0	17%	B23	Basic		B72	Basic	B	17.9	15%	C	22.1	20%
D	30.2	17%	C	21.3	21%	M24	Merge		D71	Diverge	C	23.4	21%	D	28.7	25%
D	29.1	18%	C	21.8	23%	B25	Basic	Balfour Parkway	B70	Basic	C	21.7	24%	D	29.2	23%
D	29.8	18%	C	23.2	23%	D26	Diverge		M69	Merge	C	23.7	24%	D	31.6	17%
C	28.0	18%	C	24.3	26%	D27	Diverge		B68	Basic	B	16.1	21%	C	22.0	12%
C	21.3	12%	B	16.2	18%	B28	Basic		D67	Diverge	C	23.6	26%	D	30.0	14%
D	28.9	20%	C	22.5	25%	M29	Merge	US 64	D66	Diverge	C	21.7	29%	D	28.5	24%
D	27.8	22%	C	20.6	25%	B30	Basic		B65	Basic	C	20.5	22%	D	26.1	31%
D	29.0	20%	C	21.7	25%	D31	Diverge		M64	Merge	C	22.6	24%	D	28.3	30%
C	24.1	20%	C	18.7	22%	B32	Basic		B63	Basic	B	17.8	19%	C	22.7	25%
D	28.9	5%	B	19.8	11%	W33	Weave	W62	Weave	B	17.0	13%	C	21.9	24%	
C	25.0	19%	C	18.8	22%	B34	Basic	B61	Basic	B	17.2	22%	C	21.4	27%	
D	28.3	28%	C	21.7	29%	M35	Merge	D60	Diverge	C	20.5	26%	C	25.7	31%	
D	26.5	28%	C	19.6	28%	B36	Basic	Upward Road (SR 1783)	B59	Basic	C	19.4	25%	C	25.0	32%
D	28.3	25%	C	21.4	28%	D37	Diverge		M58	Merge	C	21.3	26%	C	27.1	29%
C	20.6	25%	B	15.8	27%	B38	Basic		B57	Basic	B	15.7	24%	C	19.6	30%
F	57.1	-43%	C	21.3	34%	M39	Merge		D56	Diverge	C	22.2	28%	C	27.4	29%
E	42.6	-8%	D	32.8	-5%	D40	Diverge	US 25 (System)	M55	Merge	D	31.8	-5%	E	43.0	-9%
D	26.6	-6%	C	21.0	-2%	B41	Basic		B54	Basic	C	21.0	-4%	C	25.9	-6%
D	29.0	-5%	C	23.5	-2%	M42	Merge		D53	Diverge	C	26.5	-4%	D	32.1	-13%
D	26.6	-6%	C	21.2	-2%	B43	Basic		B52	Basic	C	20.8	-5%	D	26.2	-4%
D	29.7	-4%	C	24.0	-2%	D44	Diverge	Holbert Cove Road (SR 1142)	M51	Merge	C	23.5	-4%	D	29.2	-4%
C	25.3	-8%	C	19.6	-2%	B45	Basic		B50	Basic	C	19.3	-4%	C	24.4	-4%
D	30.1	-8%	C	23.5	-2%	M46	Merge		D49	Diverge	C	23.2	-5%	D	28.7	-1%
D	27.2	-8%	C	20.8	-1%	B47	Basic	B48	Basic	C	20.4	3%	D	26.4	-5%	

Density = Passenger Cars Equivalent/Mile/Lane
% Improvement = Percentage Change in Density Between Build Alternative and No-Build Alternative By Segment

Table 9. 2040 Design Year Build - 8 Lanes Alternative - Freeway Operations Summary

I-26 Southbound						Y-Line	I-26 Northbound									
AM			PM				ID#	Type	AM			PM				
LOS	Density	% Imprv	LOS	Density	% Imprv				LOS	Density	% Imprv	LOS	Density	% Imprv		
D	28.2	34%	C	22.0	47%	B1	Basic	NC 191 (Brevard Road)	B94	Basic	C	22.1	44%	D	26.8	40%
D	29.1	39%	C	24.3	45%	D2	Diverge		M93	Merge	C	24.1	44%	D	28.9	38%
C	24.6	54%	C	20.0	38%	B3	Basic		B92	Basic	C	20.0	36%	C	23.8	52%
D	31.5	31%	C	24.8	46%	M4	Merge		D91	Diverge	C	25.4	43%	D	28.6	33%
D	28.8	35%	C	22.8	47%	B5	Basic	NC 146 (Long Shoals Road)	B90	Basic	C	22.8	45%	D	27.4	39%
D	29.6	32%	C	23.7	43%	D6	Diverge		M89	Merge	C	24.9	43%	D	29.4	35%
C	22.8	21%	B	17.9	33%	B7	Basic		B88	Basic	B	17.9	31%	C	21.7	67%
D	29.0	32%	C	23.1	40%	M8	Merge		D87	Diverge	C	22.3	37%	C	27.3	36%
D	27.2	34%	C	21.3	39%	B9	Basic	NC 280 (Airport Road)	B86	Basic	C	21.3	37%	C	25.8	43%
D	29.3	30%	C	22.9	38%	D10	Diverge		M85	Merge	C	22.8	36%	C	27.3	37%
C	20.2	20%	B	15.5	30%	B11	Basic		B84	Basic	B	15.5	27%	C	19.0	30%
C	26.7	36%	C	21.2	43%	M12	Merge		D83	Diverge	C	20.8	41%	C	25.7	41%
C	25.1	39%	C	20.0	41%	B13	Basic	Rest Stop	B82	Basic	C	20.0	38%	C	24.2	47%
C	25.8	36%	C	20.1	42%	D14	Diverge		M81	Merge	C	20.9	40%	C	25.8	45%
C	23.9	38%	C	18.7	40%	B15	Basic		B80	Basic	C	18.6	38%	C	22.7	39%
C	26.8	40%	C	21.0	42%	M16	Merge		D79	Diverge	C	20.1	41%	C	24.9	41%
C	24.9	42%	C	19.7	42%	B17	Basic	US 25 (Asheville Highway)	B78	Basic	C	19.7	39%	C	23.9	47%
C	26.7	37%	C	20.8	42%	D18	Diverge		M77	Merge	C	21.1	40%	C	25.6	43%
C	19.8	25%	B	15.5	32%	B19	Basic		B76	Basic	B	15.4	30%	C	18.7	34%
C	25.2	34%	B	19.7	40%	M20	Merge		D75	Diverge	B	19.2	39%	C	23.8	41%
C	22.1	36%	B	17.1	40%	B21	Basic	Weigh Station	B74	Basic	B	17.1	37%	C	21.0	44%
C	23.6	35%	B	18.0	42%	D22	Diverge		M73	Merge	B	16.6	36%	C	22.1	42%
C	18.2	29%	B	14.5	33%	B23	Basic		B72	Basic	B	14.5	31%	B	17.6	36%
C	23.4	36%	B	16.6	38%	M24	Merge		D71	Diverge	B	18.0	40%	C	22.4	41%
C	22.1	38%	B	17.1	40%	B25	Basic	Balfour Parkway	B70	Basic	B	17.1	40%	C	21.0	44%
C	23.1	36%	B	17.7	41%	D26	Diverge		M69	Merge	B	18.4	41%	C	22.1	42%
C	21.1	38%	B	18.1	45%	D27	Diverge		B68	Basic	B	12.8	37%	B	16.0	36%
B	17.5	28%	B	12.8	35%	B28	Basic		D67	Diverge	B	17.5	45%	B	19.8	43%
C	22.3	39%	B	17.3	43%	M29	Merge	US 64	D66	Diverge	B	16.5	46%	C	20.6	45%
C	21.1	41%	B	16.2	41%	B30	Basic		B65	Basic	B	16.3	38%	C	19.9	47%
C	22.2	39%	B	16.4	43%	D31	Diverge		M64	Merge	B	17.5	41%	C	21.2	48%
C	19.1	37%	B	14.6	39%	B32	Basic		B63	Basic	B	13.9	37%	B	17.7	41%
C	24.5	19%	B	16.6	26%	W33	Weave	Upward Road (SR 1783)	W62	Weave	B	13.9	29%	C	20.1	31%
C	20.0	35%	B	14.5	40%	B34	Basic		B61	Basic	B	13.2	40%	B	16.5	44%
C	21.5	46%	B	16.1	47%	M35	Merge		D60	Diverge	B	15.2	45%	B	19.7	47%
C	19.9	46%	B	14.9	45%	B36	Basic		B59	Basic	B	14.9	43%	C	18.6	50%
C	21.5	43%	B	15.8	47%	D37	Diverge	US 25 (System)	M58	Merge	B	16.0	45%	B	19.6	49%
B	14.9	46%	B	11.9	45%	B38	Basic		B57	Basic	B	11.9	43%	B	14.8	48%
F	58.5	-47%	B	15.2	53%	M39	Merge		D56	Diverge	B	14.9	52%	B	18.3	53%
E	42.7	-9%	D	32.8	-5%	D40	Diverge		M55	Merge	D	32.1	-6%	E	43.1	-9%
D	26.5	-5%	C	20.8	-1%	B41	Basic	Holbert Cove Road (SR 1142)	B54	Basic	C	21.0	-4%	C	25.9	-6%
D	29.7	-7%	C	23.3	-1%	M42	Merge		D53	Diverge	C	26.6	-4%	D	29.5	-4%
D	27.2	-8%	C	21.0	-1%	B43	Basic		B52	Basic	C	20.9	-5%	D	26.5	-5%
D	30.2	-6%	C	23.8	-1%	D44	Diverge		M51	Merge	C	23.6	-5%	D	29.4	-5%
C	25.3	-8%	C	19.4	-1%	B45	Basic	US 25 (System)	B50	Basic	C	19.3	-4%	C	24.7	-5%
D	30.0	-8%	C	23.3	-1%	M46	Merge		D49	Diverge	C	23.2	-5%	D	29.7	-4%
D	27.2	-8%	C	20.6	0%	B47	Basic	B48	Basic	C	20.5	2%	D	26.5	-5%	

Density = Passenger Cars Equivalent/Mile/Lane
% Improvement = Percentage Change in Density Between Build Alternative and No-Build Alternative By Segment

7.2 2040 Design Year Intersection Capacity Analysis Results

The following sections provide descriptions and tabular results for intersection capacity analyses for all project study area intersections. LOS results and additional details for these scenarios are found in the raw Synchro output sheets in **Appendix D**. The project study area contains two unsignalized intersections – these capacity analysis output sheets are found in **Appendix E**. The following are the anticipated changes to the study area freeway network between the 2011 and 2040 analysis years, regardless of alternative scenario analyzed.

Balfour Parkway Interchange

As described in Section 7.1, the planned Balfour Parkway project (FS 1214B) is currently under study by NCDOT, but no results are available for potential interchange forms at the Balfour Parkway crossing of I-26. The assumed partial cloverleaf interchange studied in this report provides two ramp terminal intersections with the future Balfour Parkway which was assumed to be a four-lane divided cross-section in the interchange vicinity. Intersection capacity analyses with 2040 design year peak hour traffic volumes were conducted to determine preliminary laneage configurations, signal phasing and timing, and auxiliary turn bay lengths that would meet projected 2040 peak hour traffic demands as derived from the 2040 NCDOT traffic forecast data.

Figure 6.1 shows potential laneage concepts and turn bay lengths that provide adequate capacity and operations in all 2040 alternative scenarios.

Upward Road Interchange

As described in previous sections, the NCDOT STIP R-4430 is currently under construction, widening Upward Road to a four-lane divided facility in the vicinity of the existing I-26 interchange and providing additional auxiliary lanes and ramp improvements to the interchange signalized ramp terminals. **Figure 6.1** shows these laneage changes.

NC 280 Interchange

Though not specifically analyzed in this analysis, the operational improvements currently proposed by NCDOT for STIP I-5501 are included in **Figure 6.2** for reference. Subsequent 2040 design year traffic volume, laneage, and results tables for the project study area include this interchange to present the proposed laneage and projected traffic volumes for each alternative scenario.

A tabular results summary for all 2040 design year alternative scenarios is found in **Table 10**.

Table 10. 2040 AM & (PM) Peak Hour No-Build/Build Intersection Capacity Analysis Results Summary

Intersection (ID#)	2040 No-Build Alternative						2040 – Build 6 Lanes Alternative						2040 – Build 8 Lanes Alternative												
	LOS	Delay	Approach	LOS	Delay	Movmnt	LOS	Delay	LOS	Delay	Approach	LOS	Delay	Movmnt	LOS	Delay	LOS	Delay	Approach	LOS	Delay	Movmnt	LOS	Delay	
I-26 Ramps & NC 146 (Long Shoals Rd) SPU1 (1)	C (C)	30.5 (30.0)	EB	C (C)	33.2 (32.4)	EB LT	E (D)	57.6 (46.6)	C (C)	32.6 (32.7)	EB	C (C)	33.0 (30.9)	EB LT	E (D)	60.3 (48.3)	D (C)	35.3 (33.9)	EB	D (C)	36.4 (32.2)	EB LT	E (D)	74.2 (51.5)	
						EB TH	D (D)	36.2 (36.1)						EB TH	D (C)	37.1 (34.9)						EB TH	D (D)	37.7 (36.0)	
						EB RT	A (A)	0.4 (0.4)						EB RT	A (A)	0.5 (0.5)						EB RT	A (A)	0.5 (0.5)	
			WB	C (C)	27.4 (25.1)	WB LT	D (E)	53.8 (63.6)			WB	C (C)	32.3 (34.1)	WB LT	E (F)	72.0 (101.4)			WB	D (C)	35.0 (34.1)	WB LT	F (F)	81.7 (101.4)	
						WB TH	C (C)	34.7 (30.2)						WB TH	C (C)	34.7 (30.0)						WB TH	D (C)	36.2 (30.5)	
						WB RT	A (A)	1.7 (1.6)						WB RT	A (A)	1.8 (1.6)						WB RT	A (A)	1.9 (1.7)	
	NB	B (B)	12.5 (11.6)	NB LT	C (C)	27.2 (29.2)	NB	B (B)	13.2 (12.4)	NB LT	C (C)	28.1 (30.3)	NB	B (B)	13.6 (13.0)	NB LT	C (C)	28.1 (30.8)							
				NB RT	A (A)	0.4 (0.6)				NB RT	A (A)	0.5 (0.8)				NB RT	A (A)	0.5 (0.8)							
				SB	D (D)	44.5 (47.8)				SB LT	D (D)	39.7 (49.6)				SB	D (D)	46.0 (49.9)	SB LT	D (D)	39.9 (51.6)	SB	D (D)	49.1 (53.4)	SB LT
	SB RT	D (D)	52.8 (43.0)	SB RT			E (D)	58.3 (45.5)	SB RT	E (D)	67.7 (51.0)														
	I-26 NB Ramps & US 25 (Asheville Hwy) (2)	F (F)	161.1 (174.5)	WB	F (F)	117.1 (223.6)	WB LT	F (F)	218.9 (183.8)	F (F)	142.1 (169.2)	WB	F (F)	104.5 (305.0)	WB LT	F (F)	177.8 (147.6)	F (F)	131.7 (165.7)	WB	F (F)	93.3 (335.2)	WB LT	F (F)	124.6 (105.6)
							WB RT	D (F)	45.1 (246.0)						WB RT	E (F)	65.1 (371.9)						WB RT	E (F)	79.5 (415.5)
NB				F (F)	112.3 (127.7)	NB LT	F (F)	282.5 (304.8)	NB			F (F)	93.4 (107.5)	NB LT	F (F)	236.0 (256.8)	NB			F (F)	84.5 (97.7)	NB LT	F (F)	217.2 (236.6)	
						NB TH	A (B)	2.8 (11.1)						NB TH	A (A)	1.7 (8.6)						NB TH	A (A)	1.7 (8.0)	
SB				F (F)	225.4 (222.0)	SB TH	F (F)	253.1 (255.8)	SB			F (F)	202.3 (184.2)	SB TH	F (F)	233.8 (220.0)	SB			F (F)	189.1 (170.1)	SB TH	F (F)	224.8 (209.9)	
						SB RT	A (A)	0.2 (0.2)						SB RT	A (A)	0.3 (0.3)						SB RT	A (A)	0.4 (0.4)	
I-26 SB Ramps & US 25 (Asheville Hwy) (3)	F (F)	265.6 (259.8)	EB	F (F)	427.9 (363.5)	EB LT	C (D)	30.1 (39.5)	F (F)	251.8 (229.4)	EB	F (F)	359.7 (281.7)	EB LT	C (D)	32.2 (44.1)	F (F)	250.1 (220.6)	EB	F (F)	326.2 (242.3)	EB LT	C (D)	34.8 (51.4)	
						EB RT	F (F)	515.2 (453.0)						EB RT	F (F)	454.4 (368.3)						EB RT	F (F)	429.0 (327.9)	
			NB	F (F)	321.3 (312.5)	NB TH	F (F)	371.4 (351.7)			NB	F (F)	253.1 (240.8)	NB TH	F (F)	293.4 (271.5)			NB	F (F)	230.1 (217.5)	NB TH	F (F)	263.4 (242.6)	
						NB RT	A (A)	0.3 (0.3)						NB RT	A (A)	0.3 (0.3)						NB RT	A (A)	0.3 (0.3)	
			SB	F (F)	114.7 (119.0)	SB LT	F (F)	428.5 (377.5)			SB	F (F)	186.3 (180.8)	SB LT	F (F)	598.1 (533.6)			SB	F (F)	221.0 (210.6)	SB LT	F (F)	656.2 (584.7)	
						SB TH	B (D)	13.6 (39.0)						SB TH	A (C)	4.7 (31.4)						SB TH	A (C)	2.8 (30.4)	
I-26 NB Ramps & Future Balfour Parkway (4)	B (B)	18.6 (16.0)	EB	E (D)	55.6 (50.7)	EB RT	E (D)	55.6 (50.7)	C (C)	26.6 (25.3)	EB	E (E)	77.3 (68.5)	EB RT	E (E)	77.3 (68.5)	C (C)	30.7 (33.5)	EB	F (E)	86.8 (76.2)	EB RT	F (E)	86.8 (76.2)	
						WB	A (A)	0.2 (0.3)						WB RT	A (A)	0.2 (0.3)						WB	A (A)	0.2 (0.3)	WB RT
			NB	A (A)	3.8 (5.1)	NB LT	C (C)	25.3 (31.7)			NB	A (B)	6.6 (14.7)	NB LT	C (E)	33.9 (71.2)			NB	B (C)	10.0 (28.5)	NB LT	D (F)	46.6 (125.2)	
						NB TH	A (A)	0.3 (0.3)						NB TH	A (A)	6.6 (0.3)						NB TH	A (A)	0.3 (0.3)	
			SB	C (B)	20.8 (19.0)	SB TH	B (B)	13.2 (10.6)			SB	C (C)	28.4 (24.7)	SB TH	C (B)	28.4 (10.1)			SB	C (C)	31.4 (26.6)	SB TH	B (A)	11.9 (9.9)	
						SB RT	C (C)	33.5 (29.7)						SB RT	D (D)	51.2 (40.3)						SB RT	E (D)	57.3 (43.6)	
I-26 SB Ramps & Future Balfour Parkway (5)	B (B)	15.8 (18.3)	EB	A (A)	0.3 (0.2)	EB RT	A (A)	0.3 (0.2)	B (C)	18.4 (23.3)	EB	A (A)	0.5 (0.3)	EB RT	A (A)	0.5 (0.3)	B (C)	16.6 (25.4)	EB	A (A)	0.6 (0.4)	EB RT	A (A)	0.6 (0.4)	
						WB	D (D)	42.4 (44.8)						WB RT	D (E)	49.5 (58.8)						WB	D (E)	39.7 (64.1)	WB RT
			NB	B (C)	19.8 (22.1)	NB TH	B (B)	13.4 (16.8)			NB	C (C)	25.1 (28.1)	NB TH	B (B)	14.1 (18.1)			NB	C (C)	26.0 (31.0)	NB TH	B (B)	13.9 (18.8)	
						NB RT	C (C)	28.8 (32.1)						NB RT	D (D)	40.1 (46.2)						NB RT	D (D)	42.5 (53.2)	
			SB	A (A)	4.9 (3.6)	SB LT	C (C)	25.9 (20.4)			SB	A (A)	3.8 (2.8)	SB LT	C (B)	23.2 (18.6)			SB	A (A)	3.6 (2.6)	SB LT	C (B)	23.1 (18.1)	
						SB TH	A (A)	4.9 (0.3)						SB TH	A (A)	0.3 (0.3)						SB TH	A (A)	0.3 (0.3)	

Delay Measured In Seconds Per Vehicle

BOLD/ITALIC = Intersection/Approach/Movement that has Operational Deficiencies (LOS E or F)

Table 10 Cont'd. 2040 AM & (PM) Peak Hour No-Build/Build Intersection Capacity Analysis Results Summary

Intersection (ID#)	2040 No-Build Alternative						2040 – Build 6 Lanes Alternative						2040 – Build 8 Lanes Alternative											
	LOS	Delay	Approach	LOS	Delay	Movmnt	LOS	Delay	Approach	LOS	Delay	Movmnt	LOS	Delay	Approach	LOS	Delay	Approach	LOS	Delay	Movmnt	LOS	Delay	
US 64 & Francis Road / Sugarloaf Rd (6)	E (D)	62.7 (52.2)	EB	C (D)	30.6 (44.5)	EB LT	F (F)	206.3 (135.7)	E (E)	74.0 (60.7)	EB	C (E)	31.0 (60.3)	EB LT	F (F)	202.0 (150.6)	F (E)	82.3 (66.7)	EB	C (E)	31.6 (65.9)	EB LT	F (F)	220.0 (157.3)
						EB TH	B (D)	18.1 (44.6)						EB TH	B (E)	18.6 (63.3)						EB TH	B (E)	17.9 (70.2)
						EB RT	B (B)	13.5 (13.0)						EB RT	B (B)	13.7 (14.2)						EB RT	B (B)	13.0 (14.1)
			WB	F (D)	89.0 (43.1)	WB LT	F (F)	106.5 (151.8)			WB LT	F (F)	111.1 (113.7)	WB LT	F (F)	82.2 (90.8)								
						WB THRT	F (D)	88.2 (38.5)			WB THRT	F (D)	115.8 (43.1)	WB THRT	F (D)	136.3 (49.2)								
						NB LT	F (F)	93.5 (113.6)			NB LT	F (F)	92.6 (96.3)	NB LT	F (F)	82.5 (103.5)								
			NB	F (F)	85.5 (101.9)	NB LTTH	F (F)	90.7 (109.2)			NB LTTH	F (F)	90.2 (93.6)	NB LTTH	F (F)	80.4 (106.5)								
						NB RT	D (E)	45.2 (55.9)			NB RT	D (D)	46.7 (52.3)	NB RT	D (D)	44.3 (51.4)								
						SB LTTH	E (F)	76.2 (95.2)			SB LTTH	E (F)	72.1 (86.5)	SB LTTH	E (F)	70.9 (82.8)								
			SB	F (F)	81.7 (90.1)	SB RT	F (F)	82.8 (88.9)			SB RT	F (F)	83.2 (124.0)	SB RT	F (F)	109.0 (135.3)								
						EB TH	A (A)	0.0 (1.5)			EB TH	A (A)	0.1 (1.8)	EB TH	A (A)	0.1 (2.3)								
						EB RT	A (A)	0.0 (0.0)			EB RT	A (A)	0.0 (0.0)	EB RT	A (A)	0.0 (0.0)								
WB	B (B)	15.2 (11.9)	WB TH	B (B)	16.1 (11.4)	WB TH	B (B)	17.3 (12.8)	WB TH	B (B)	17.3 (12.8)	WB TH	B (B)	18.0 (13.6)										
			SB	E (F)	78.8 (88.4)	SB RT	E (F)	77.6 (87.4)	SB RT	E (F)	79.0 (87.0)													
			WB	B (B)	16.1 (11.4)	WB TH	B (B)	17.3 (12.8)	WB TH	B (B)	18.0 (13.6)													
US 64 & Carolina Village Rd / Orr's Camp Rd (8)	F (F)	107.6 (106.1)	EB	F (F)	91.7 (141.3)	EB LT	F (F)	123.7 (153.6)	F (F)	106.6 (105.9)	EB	F (F)	91.7 (141.3)	EB LT	F (F)	123.7 (153.6)	F (F)	110.5 (108.5)	EB	F (F)	92.5 (143.9)	EB LT	F (F)	115.1 (139.6)
						EB THRT	F (F)	90.4 (140.8)						EB THRT	F (F)	90.4 (140.8)						EB THRT	F (F)	91.7 (144.1)
						WB LT	F (F)	160.9 (219.7)						WB LT	F (F)	160.3 (220.2)						WB LT	F (F)	168.7 (233.5)
			WB	F (D)	112.7 (49.9)	WB TH	F (D)	116.8 (35.5)			WB TH	F (D)	117.0 (35.0)	WB TH	F (D)	122.1 (36.0)								
						WB RT	B (B)	17.1 (15.4)			WB RT	B (B)	17.2 (15.4)	WB RT	B (B)	17.4 (15.3)								
						NB LTR	F (F)	146.1 (194.4)			NB LTR	F (F)	137.5 (194.4)	NB LTR	F (F)	139.8 (191.0)								
			NB	F (F)	146.1 (194.4)	SB LTTH	F (F)	157.3 (162.8)			SB LTTH	F (F)	147.1 (162.8)	SB LTTH	F (F)	163.7 (180.6)								
						SB RT	C (C)	32.8 (34.9)			SB RT	C (C)	32.8 (34.9)	SB RT	C (C)	32.6 (34.7)								
						EB	C (B)	24.3 (15.7)			EB LT	D (C)	51.5 (31.7)	EB LT	C (C)	32.4 (24.7)								
			WB	C (C)	32.2 (28.7)	EB TH	A (A)	3.3 (2.8)			EB TH	A (A)	1.8 (2.3)	EB TH	A (A)	1.8 (2.2)								
						WB THRT	C (C)	27.9 (30.7)			WB THRT	C (C)	29.4 (32.2)	WB THRT	C (C)	28.7 (31.4)								
						NB	D (D)	47.5 (47.2)			NB LT	D (D)	51.3 (49.5)	NB LT	E (E)	57.6 (59.3)								
NB	D (D)	47.5 (47.2)	NB RT	D (D)	35.0 (41.4)	NB RT	D (D)	36.7 (43.2)	NB RT	D (D)	35.6 (41.3)													
			EB	C (C)	26.0 (21.2)	EB TH	B (A)	16.2 (2.8)	EB TH	C (C)	22.6 (20.0)													
			EB RT	D (C)	40.8 (34.0)	EB RT	D (D)	51.5 (36.5)	EB RT	D (D)	46.8 (34.9)													
WB	A (A)	23.6 (19.8)	WB LT	B (B)	14.8 (16.4)	WB LT	B (B)	19.2 (19.9)	WB LT	B (B)	18.6 (19.2)													
			WB TH	A (A)	4.4 (1.5)	WB TH	A (A)	3.7 (4.6)	WB TH	A (A)	3.5 (4.8)													
			SB LTTH	C (D)	30.1 (35.0)	SB LTTH	C (C)	24.3 (29.3)	SB LTTH	C (C)	24.5 (29.3)													
SB	D (D)	54.0 (49.6)	SB RT	E (D)	59.5 (54.0)	SB RT	E (D)	59.6 (51.6)	SB RT	E (D)	82.1 (61.4)													
			EB	N/A	N/A	EB LT	A (A)	7.8 (7.8)	EB LT	A (A)	7.8 (7.8)													
			NB	B (B)	12.0 (13.3)	NB LT	B (B)	14.2 (15.0)	NB LT	B (B)	14.6 (14.5)													
I-26 NB Ramps & Holbert Cove Road (11)	N/A	N/A	NB RT	A (A)	8.9 (9.0)	NB RT	A (A)	9.1 (8.9)	NB RT	A (A)	9.1 (8.9)													
			WB	N/A	N/A	WB LT	A (A)	8.1 (7.8)	WB LT	A (A)	8.1 (7.8)													
			SB	B (B)	11.0 (10.9)	SB LT	B (B)	13.3 (13.0)	SB LT	B (B)	13.3 (13.0)													
I-26 SB Ramps & Holbert Cove Road (12)	N/A	N/A	SB RT	A (B)	9.3 (10.1)	SB RT	A (B)	9.3 (10.1)	SB RT	A (B)	9.3 (10.1)													

N/A – LOS/Delay Not Calculated for Overall Unsignalized Intersection or Non-Stop-Controlled Approaches

Delay Measured In Seconds Per Vehicle

BOLD/ITALIC = Intersection/Approach/Movement that has Operational Deficiencies (LOS E or F)

7.2.1 2040 No-Build Alternative Scenario Results

For the 2040 No-Build alternative AM and PM peak hour scenarios, the signalized ramp terminal intersections along the I-26 study area corridor generally operate at or have movements that operate at adequate levels of service in the AM and PM peak hours. Reoptimization of all signal timings was employed in the 2040 No-Build alternative analyses. Several notable results include:

- ◆ The existing SPUI configuration at NC 146 (Long Shoals Road) is expected to provide adequate overall peak hour LOS, regardless of alternative scenario in the 2040 design year.
- ◆ The US 25 (Asheville Highway) ramp terminal intersections are expected to experience overall LOS F, with several critical approaches and movements experiencing LOS F and excessive queues and spillback in the 2040 design year – if no geometric improvements are made to the facility, and regardless of I-4400/I-4700 alternative scenario.
- ◆ The US 64 intersections with Francis Road/Sugarloaf Road and Carolina Village Road/Orr's Camp Road are expected to operate at overall intersection LOS E or F in at least one peak hour in every alternative scenario for 2040 conditions.

Traffic volumes, geometrics, and overall intersection LOS results are also found in **Figures 7.1 to 7.4** for the study area intersections in the 2040 No-Build alternative scenario.

7.2.2 2040 Build – 6 Lane Alternative Scenario Results

For the 2040 Build – 6 Lane alternative AM and PM peak hour scenarios, it was assumed that all signalized intersections in the project study area would be reoptimized, to reflect anticipated traffic volume changes that were included in the I-4400/I-4700 traffic forecast data. These changes had only minor effects (some positive, some negative, depending on the projected volume changes) on operations at most study area ramp terminal intersections.

Traffic volumes, geometrics, and overall intersection LOS results are also found in **Figures 8.1 to 8.4** for the study area intersections in the 2040 Build – 6 Lane alternative scenario.

7.2.3 2040 Build – 8 Lane Alternative Scenario Results

In the 2040 Build – 8 Lane alternative AM and PM peak hour scenarios, it was assumed that all signal timings that were optimized in the 2040 Build – 6 Lane scenario would be held constant, to provide a meaningful comparison between the two Build alternatives. As shown in **Table 10**, the additional or redistributed traffic volumes projected in the project-level traffic forecast have small negative impacts on study area intersection operations. In most cases, overall intersection delays increase by less than five seconds between the 6-Lane and 8-Lane alternative scenarios. Traffic volumes, geometrics, and overall intersection LOS results are also found in **Figures 9.1 to 9.4** for the study area intersections in the 2040 Build – 8 Lane alternative scenario.

8. SAFETY EVALUATION

Crash data was provided from the NCDOT Traffic Safety Unit for a 30.36-mile section of I-26 from the I-40/I-240/I-26 system interchange in Buncombe County through Henderson County to SR 1142 (Holbert Cove Road) in Polk County from July 1, 2009 to June 31, 2012. The raw crash data files and summary report provided by NCDOT can be found in **Appendix H. Table 11** presents a comparison between the I-26 study area crash rates and the latest North Carolina statewide rates for the period 2008-2010 (the latest available information compiled by NCDOT Traffic Safety Unit) for the entire study area corridor. There were 1,006 crashes reported along the I-26 study area corridor over the three year period. Nine fatal crashes and 265 injury crashes were also reported. The most frequent accident types are rear end (slow or stop), fixed object and sideswipe (same direction) at 38 percent, 20 percent and 16 percent, respectively, of the 1,006 total crashes. Current crash rates exceed the statewide crash rates in the fatal category only and do not exceed the critical crash rates in any categories.

Table 11. I-26 Study Area Crash Rate Comparison

Rate	Crashes	Crashes per 100 MVMT	Statewide Rate¹	Critical Rate²
Total	1,006	52.13	78.21	81.55
Fatal	9	0.47	0.43	0.70
Non-Fatal Injury	265	13.73	21.69	23.46
Night	248	12.85	22.26	24.05
Wet	201	10.41	20.08	21.78

¹ 2008-2010 statewide crash rate for all Interstates (four-lane divided interstate freeway).

² Based on the statewide crash rate (95% level of confidence).

The I-26 corridor was further analyzed by dividing the corridor into individual freeway segments and by direction of travel to potentially identify areas of safety concerns, as shown in **Table 12** on the following page. The two types of bi-directional segments in the project study area are 1) interchange “influence” areas designated to be ½ mile on either side of the interchange y-line crossing and 2) freeway mainline segments between these “influence” areas. Based on this I-26 segment crash analysis for total crashes, two of nine interchange areas and zero of eight mainline segments exceed the statewide and/or critical crash rates. For total crashes by direction, three of nine eastbound and one of nine westbound interchange areas exceed the statewide and/or critical crash rates. For non-fatal crashes by direction, four of nine eastbound and five of nine westbound interchange areas exceed the statewide and/or critical crash rates.

The total crash rates along I-26 in the project study area are generally lower than statewide and critical rates for similar facilities for all segments along the study area corridor except for the following locations:

- I-40 / I-240 interchange area (Exit 31) – I-26 Eastbound
- NC 191 interchange area (Exit 33) – I-26 Eastbound
- NC 146 interchange area (Exit 37) – I-26 Eastbound and Westbound

NCDOT STIP I-4400/I-4700: I-26 Widening (Buncombe & Henderson Counties)

Purpose and Need Traffic Analysis Technical Memorandum

Table 12. I-26 Study Area Interchange and Mainline Crash Rates

Features	Segment Type	Mile-post	Distance (miles)*	Total Segment Crashes		Dir.	Total Segment Crashes (Directional)***		Fatal Crashes (Directional)		Non-Fatal (Directional)		Night (Directional)		Wet (Directional)	
				Crashes	Crash Rate**		Crashes	Crash Rate	Crashes	Crash Rate	Crashes	Crash Rate	Crashes	Crash Rate	Crashes	Crash Rate
2008-10 Statewide Rates ¹	Interstates	N/A	N/A	N/A	78.21	N/A	N/A	78.21	N/A	0.43	N/A	21.69	N/A	22.26	N/A	20.08
Critical Rates ²					81.55			81.55		0.70		23.46		24.05		21.78
I 40, I 240, US 74, Structure, Exit 31	Interchange	18.95	0.74	45	69.42	EB	30	92.56	0	0.00	9	27.77	8	24.68	11	33.94
		19.69				WB	15	46.28	0	0.00	8	24.68	1	3.09	5	15.43
	I-26 Mainline		0.32	11	39.24		11	39.24	0	0.00	5	17.84	3	10.70	7	24.97
NC 191, Brevard, Exit 33	Interchange	20.01	1	92	109.11	EB	63	149.44	1	2.37	17	40.32	14	33.21	13	30.84
		21.01				WB	29	68.79	0	0.00	8	18.98	6	14.23	8	18.98
	I-26 Mainline		3.63	227	77.17		227	77.17	0	0.00	65	22.10	54	18.36	45	15.30
NC 146, Long Shoals, Structure	Interchange	24.64	1	93	117.96	EB	40	101.47	0	0.00	13	32.98	5	12.68	9	22.83
		25.64				WB	53	134.45	0	0.00	12	30.44	12	30.44	12	30.44
	I-26 Mainline		2.12	72	44.31		72	44.31	1	0.62	21	12.92	15	9.23	11	6.77
NC 280, Airport	Interchange	27.76	1	32	46.53	EB	7	20.36	0	0.00	3	8.73	3	8.73	1	2.91
		28.76				WB	25	72.71	0	0.00	2	5.82	3	8.73	1	2.91
	I-26 Mainline		3.21	70	35.82		70	35.82	2	1.02	20	10.23	23	11.77	14	7.16
US 25, US 25BUS, Exit 44	Interchange	31.97	1	37	63.40	EB	22	75.39	0	0.00	3	10.28	9	30.84	5	17.13
		32.97				WB	15	51.40	0	0.00	4	13.71	4	13.71	1	3.43
	I-26 Mainline		4.72	90	34.14		90	34.14	1	0.38	15	5.69	26	9.86	12	4.55
US 64, Four Seasons, Exit 49	Interchange	37.69	1	36	66.82	EB	20	74.25	0	0.00	6	22.27	9	33.41	4	14.85
		38.69				WB	16	59.40	1	3.71	6	22.27	2	7.42	1	3.71
	I-26 Mainline		2.55	39	29.47		39	29.47	0	0.00	9	6.80	7	5.29	7	5.29
SR 1783, Upward, Exit 53	Interchange	41.24	1	29	58.21	EB	12	48.17	0	0.00	2	8.03	2	8.03	1	4.01
		42.24				WB	17	68.24	0	0.00	3	12.04	3	12.04	2	8.03
	I-26 Mainline		0.1	1	20.95		1	20.95	0	0.00	0	0.00	0	0.00	1	20.95
US 25, NC 225, Exit 54	Interchange	42.34	1	23	54.84	EB	9	42.92	0	0.00	3	14.31	2	9.54	3	14.31
		43.34				WB	14	66.76	1	4.77	6	28.61	5	23.84	1	4.77
	I-26 Mainline		5.47	101	51.10		101	51.10	1	0.51	23	11.64	28	14.17	25	12.65
SR 1142, Holbert Cove, Ozone, Structure	Interchange	48.81	0.5	8	44.28	EB	2	22.14	0	0.00	0	0.00	2	22.14	0	0.00
		49.31				WB	6	66.42	1	11.07	2	22.14	2	22.14	1	11.07
TOTAL			30.36	1006	52.13	All	1006	52.13	9	0.47	265	13.73	248	12.85	201	10.41

1 - 2008-2010 statewide crash rate for all Interstates

2 - Based on the statewide crash rate (95% level of confidence)

* Interchange influence area estimated at 0.5 miles upstream/downstream of interchange bridge structure. Total interchange influence area is 1.0 mile.

** Crash rates measured in crashes per 100 million vehicle miles

*** For directional crash rates, directional AADT is assumed to be half of daily AADT.

9. I-26 FAILURE YEAR ANALYSIS

A failure year mainline HCS capacity check was performed at five locations along I-26 in five year increments (year 2015, 2020, 2025, 2030, 2035) in addition to year 2011 and the 2040 design year to estimate what year freeway mainline segments are projected to reach LOS E and LOS F in the No-Build and Build conditions. The analysis results are based on individual basic freeway segments using straight-line volume interpolations between 2011 and 2040 from traffic forecast breakout sheets. Overall, the No-Build Alternative experiences LOS E and F from I-40 to NC 280 in 2011 and all segments are expected to operate at LOS E or F in the 2040 No-Build scenario. For the Build - 6 Lane Alternative, I-40 to NC 191 is projected to reach LOS E from 2015 thru 2025. By 2040, I-40 to US 25 is expected to operate at LOS E or F as a 6 lane facility. For the Build - 8 Lane Alternative, all basic freeway segments are projected to operate at LOS D or better thru 2040. To provide basic freeway LOS D or better in 2040 based on this analysis, I-26 would require an 8 lane section from I-40 to US 25 and a 6 lane section south of US 25. **Table 13** presents the analysis results and analysis output files are located **Appendix I**.

Table 13. Failure Year Analysis – I-26 Freeway Operations Summary

I-26 Basic Freeway Segment	ID #	No-Build LOS/Density						
		2011	2015	2020	2025	2030	2035	2040
I-40 to NC 191	B1	F	F	F	F	F	F	F
		64.0	67.6	72.5	78.1	84.6	92.3	101.4
NC 146 to NC 280	B2	E	F	F	F	F	F	F
		43.9	46.1	49.2	52.6	56.6	61.1	66.3
NC 280 to US 25	B3	D	D	E	E	F	F	F
		30.0	32.6	36.3	40.7	46.1	52.8	61.4
US 25 to US 64 (Balfour Pkwy in 2040)	B4	C	D	D	D	E	E	E
		25.4	27.3	29.9	32.8	36.2	40.0	44.6
US 64 to Upward Road	B5	C	C	D	D	D	E	E
		23.2	25.2	27.9	30.9	34.4	38.5	43.3
I-26 Basic Freeway Segment	ID #	Build 6 Lane LOS/Density						
		2011	2015	2020	2025	2030	2035	2040
I-40 to NC 191	B1	D	E	E	E	E	E	F
		34.1	35.5	37.5	39.6	41.9	44.5	47.3
NC 146 to NC 280	B2	D	D	D	D	E	E	E
		28.5	29.9	31.9	34.1	36.5	39.1	42.2
NC 280 to US 25	B3	C	C	C	D	D	D	E
		21.2	22.8	25.0	27.5	30.2	33.4	37.1
US 25 to US 64 (Balfour Pkwy in 2040)	B4	B	C	C	C	D	D	D
		17.7	19.3	21.3	23.6	26.0	28.8	31.9
US 64 to Upward Road	B5	B	B	C	C	C	C	D
		15.4	16.9	18.8	20.8	23.0	25.4	28
I-26 Basic Freeway Segment	ID #	Build 8 Lane LOS/Density						
		2011	2015	2020	2025	2030	2035	2040
I-40 to NC 191	B1	C	C	D	D	D	D	D
		24.2	25.1	26.2	27.4	28.7	30.0	31.4
NC 146 to NC 280	B2	C	C	C	C	D	D	D
		21.3	22.3	23.6	25.0	26.4	28.0	29.6
NC 280 to US 25	B3	B	B	C	C	C	C	D
		16.4	17.8	19.5	21.2	23.0	24.9	27
US 25 to US 64 (Balfour Pkwy in 2040)	B4	B	B	B	C	C	C	C
		13.6	14.9	16.5	18.2	19.9	21.7	23.6
US 64 to Upward Road	B5	B	B	B	B	B	C	C
		11.7	12.9	14.3	15.8	17.3	18.8	20.4

10. CONCLUSIONS AND RECOMMENDATIONS

The I-4400/I-4700 study area traffic capacity analysis was completed to evaluate existing and future peak hour traffic operations along I-26 and its study area interchanges to determine if initial study alternatives meet the purpose and need for the project. The capacity analysis results indicate that existing traffic operations issues in the project study area are related to peak hour congestion along the I-26 corridor between I-40 system interchange and NC 280 (Airport Road). The extent and duration of this congestion is expected to increase by the 2040 project design year. 68 of the 84 existing I-26 freeway segments analyzed in the project study area provide adequate (LOS D or better) operations in both peak hours in the 2011 base year. This number is expected to decrease to only 34 of 94 future freeway segments in the 2040 design year – No Build alternative, due to the projected peak hour traffic volume increases along the I-26 corridor. The two existing interchange ramp terminal intersections at the I-26 interchange with US 25 (Asheville Highway) and the US 64 intersection with Francis Road/Sugarloaf Road operate worse than a LOS D in at least one base year peak hour, with one additional intersection (US 64 and Carolina Village Road/Orr's Camp Road) in the project study area expected to degrade to a LOS E or LOS F in at least one peak hour in the 2040 design year – No Build alternative.

Three alternatives were analyzed in this study – the No-Build Alternative and the Six and Eight-Lane Widening Build Alternatives.

- The No-Build alternative assumes that no changes will be made to study area roadways in terms of geometric or traffic control improvements – other than changes to improve signal timings during AM and PM peak hours, along with the addition of the proposed Balfour Parkway interchange north of Hendersonville and improvements currently under construction for Upward Road in the vicinity of I-26. Even with improvements to signal timing that optimize projected 2040 peak hour traffic flows, all y-line signalized ramp terminal capacity and congestion issues are expected to occur, as described in the previous paragraphs. Additionally, the No-Build Alternative fails to provide adequate freeway traffic operations for a majority of the project study area corridor in the 2040 design year with 60 of 94 freeway segments projected to operate at a LOS E or F in at least one AM or PM Peak hour.
- The Build – 6 Lane alternative assumes that I-26 will be widened for an additional travel lane in each direction from the I-40/I-240/I-26 system interchange to the US 25 system interchange. No specific design details related to which side of the existing facility were assumed, nor were any improvements assumptions made for existing auxiliary acceleration/deceleration lanes or for necessary changes to existing overpass / underpass y-line facilities or interchange ramp terminals. Freeway operations results for this alternative indicate that it would mitigate all 2011 base year operational deficiencies, but would leave 20 segments over capacity (LOS E or F) in the 2040 design year in at least one peak hour. Most of these locations are to the north of the NC 280 (Airport Road) interchange.
- The Build – 8 Lane alternative assumes that I-26 will be widened for two additional travel lanes in each direction from the same project termini as described above for the six-lane alternative. Again, no specific design assumptions were made for this analysis with regards to the physical location of these lanes in relation to existing laneage and all the other items listed for the six-lane alternative above. Freeway operations results for this

alternative indicate that it will mitigate all existing 2011 base year capacity issues, along with providing adequate capacity for 92 of 94 freeway segments along the corridor in the 2040 design year in both peak hours. The only operational issues for the Build 8 – lane alternative are located at the southern ramp termini where lanes would be added/dropped to the existing system at the US 25 interchange. This same issue exists for the 2040 design year for the 6-lane alternative. Additional study may be necessary to examine the causes of these projected operational deficiencies and what additional design possibilities exist.

The safety evaluation identified that total crash rates along the 30.36-mile section of I-26 are lower than statewide and critical rates for similar facilities for all segments along the study area corridor except for the following locations:

- I-40 / I-240 interchange area (Exit 31) – I-26 Eastbound
- NC 191 interchange area (Exit 33) – I-26 Eastbound
- NC 146 interchange area (Exit 37) – I-26 Eastbound and Westbound

The most frequent accident types are rear end (slow or stop), fixed object and sideswipe (same direction) at 38 percent, 20 percent and 16 percent, respectively, of 1,006 total number of crashes.

Additional recommendations, based on freeway and intersection capacity analysis results from the I-4400/I-4700 study area include:

- A consideration should be made in the design of I-4400/I-4700 to examine an eight-lane facility for a portion of the I-26 corridor and transition to a six-lane facility for the remainder of the corridor. Based on the 2040 design year freeway system analysis results, the transition between a six-lane widening and eight-lane widening should be made at US 25 (Asheville Highway). South of this location, I-26 will function acceptably (LOS D or better) as a six-lane facility. North of this location, estimated peak hour traffic volumes require an eight-lane cross-section for acceptable operations for all freeway segments.
- Intersection capacity analysis results for study area ramp terminal intersections indicate that there will be a need to further examine capacity improvements at the US 25 (Asheville Highway) intersection and possibly study alternative interchange forms to provide adequate traffic operations at this interchange.
- Additional improvements may also be needed for the US 64 corridor signalized intersections adjacent to the I-26 interchange to prevent congestion from impacting the interchange area. These improvements may not necessarily be part of alternative designs for the I-4400/I-4700 project.
- For all freeway merge, diverge, and weaving segments along the existing I-26 corridor, additional consideration should be given in the design concepts for the Build alternatives to lengthen any sub-standard acceleration and deceleration lanes to improve operations and safety for traffic flow in these areas.

Appendix A – Figures

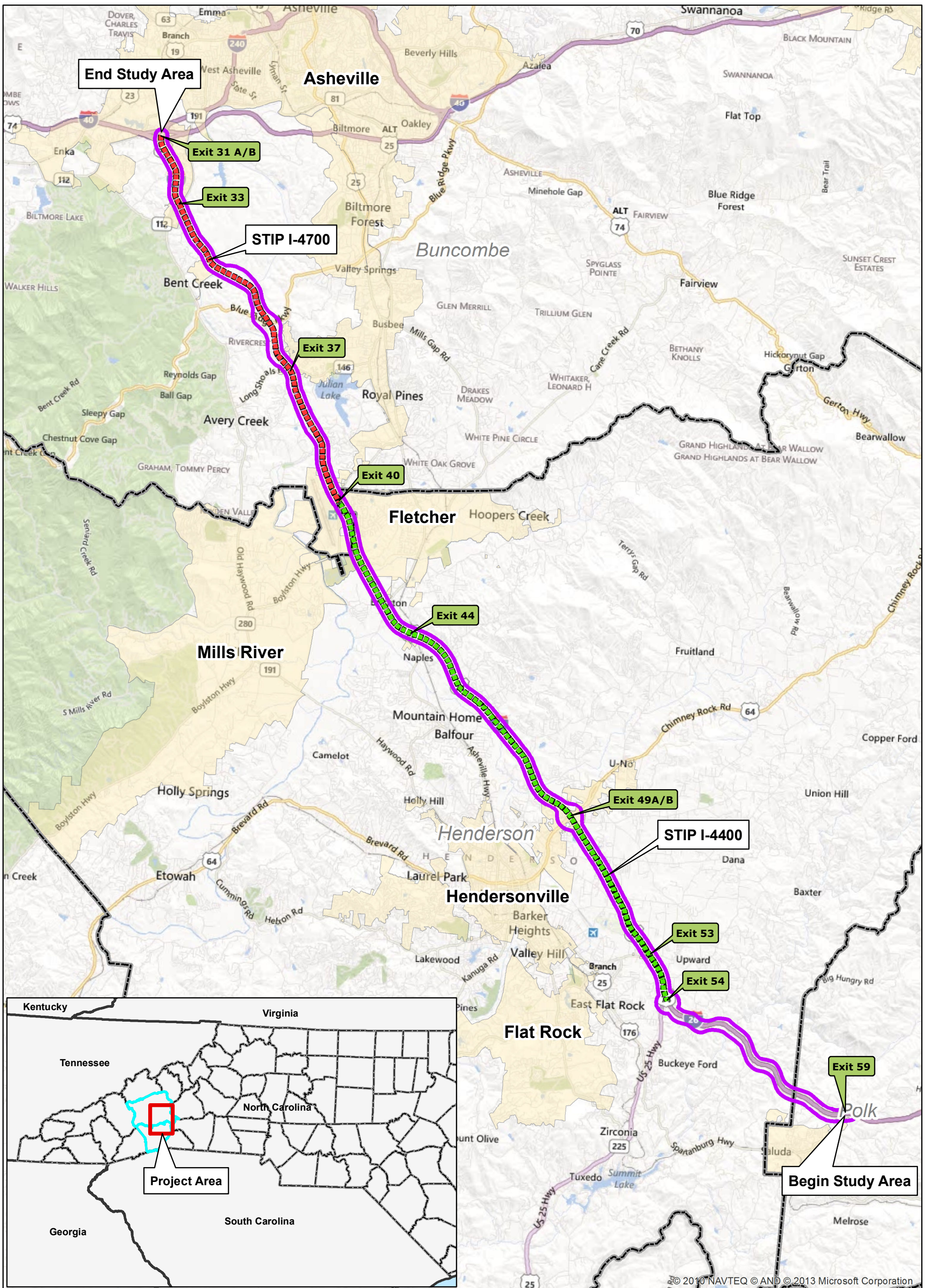

© 2010 NAVTEQ © AND © 2013 Microsoft Corporation

Traffic Analysis Study Area Figure 1
STIP Project I-4400/I-4700
September 2013

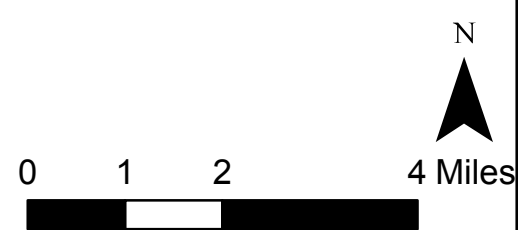

Legend

- ■ ■ ■ ■ ■ ■ ■ ■ ■ STIP Project I-4400
- ■ ■ ■ ■ ■ ■ ■ ■ ■ STIP Project I-4700
- I-4400/I-4700 Traffic Analysis Study Area



Data Sources: NCDOT, NC OneMap, Bing Maps, HNTB

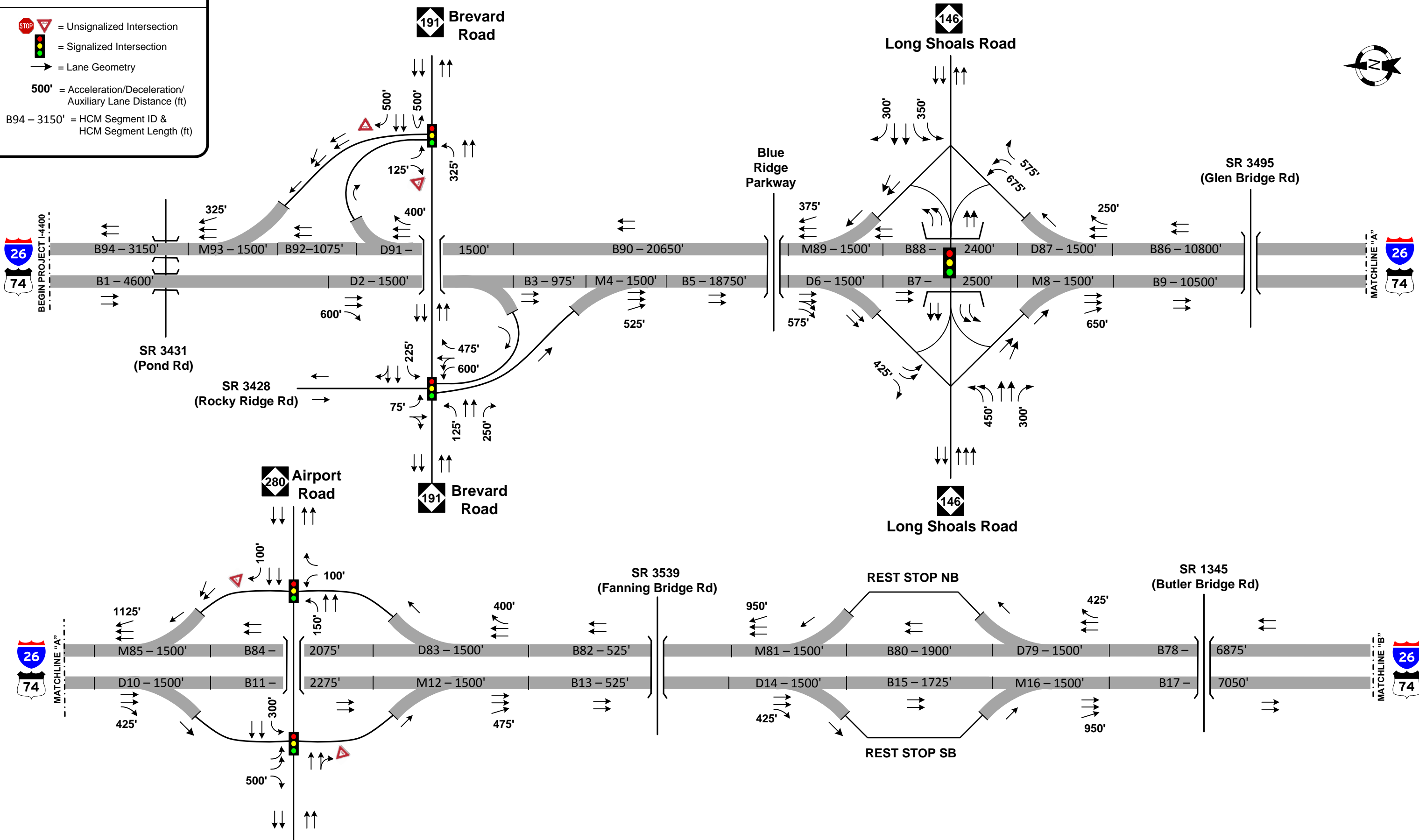

LEGEND

-  = Unsignalized Intersection
-  = Signalized Intersection
-  = Lane Geometry
- 500' = Acceleration/Deceleration/Auxiliary Lane Distance (ft)
- B94 - 3150' = HCM Segment ID & HCM Segment Length (ft)



<p>S.T.I.P. I-4400/I-4700 I-26 WIDENING BUNCOMBE AND HENDERSON COUNTIES</p>	<p>NOT TO SCALE</p>	<p>EXISTING NO BUILD LANEAGE & HCM SEGMENT ID#</p>	
		<p>DATE: September 2013</p>	<p>FIGURE 2.1</p>

LEGEND

-  = Unsignalized Intersection
-  = Signalized Intersection
-  = Lane Geometry
- 500'** = Acceleration/Deceleration/Auxiliary Lane Distance (ft)
- B94 – 3150'** = HCM Segment ID & HCM Segment Length (ft)

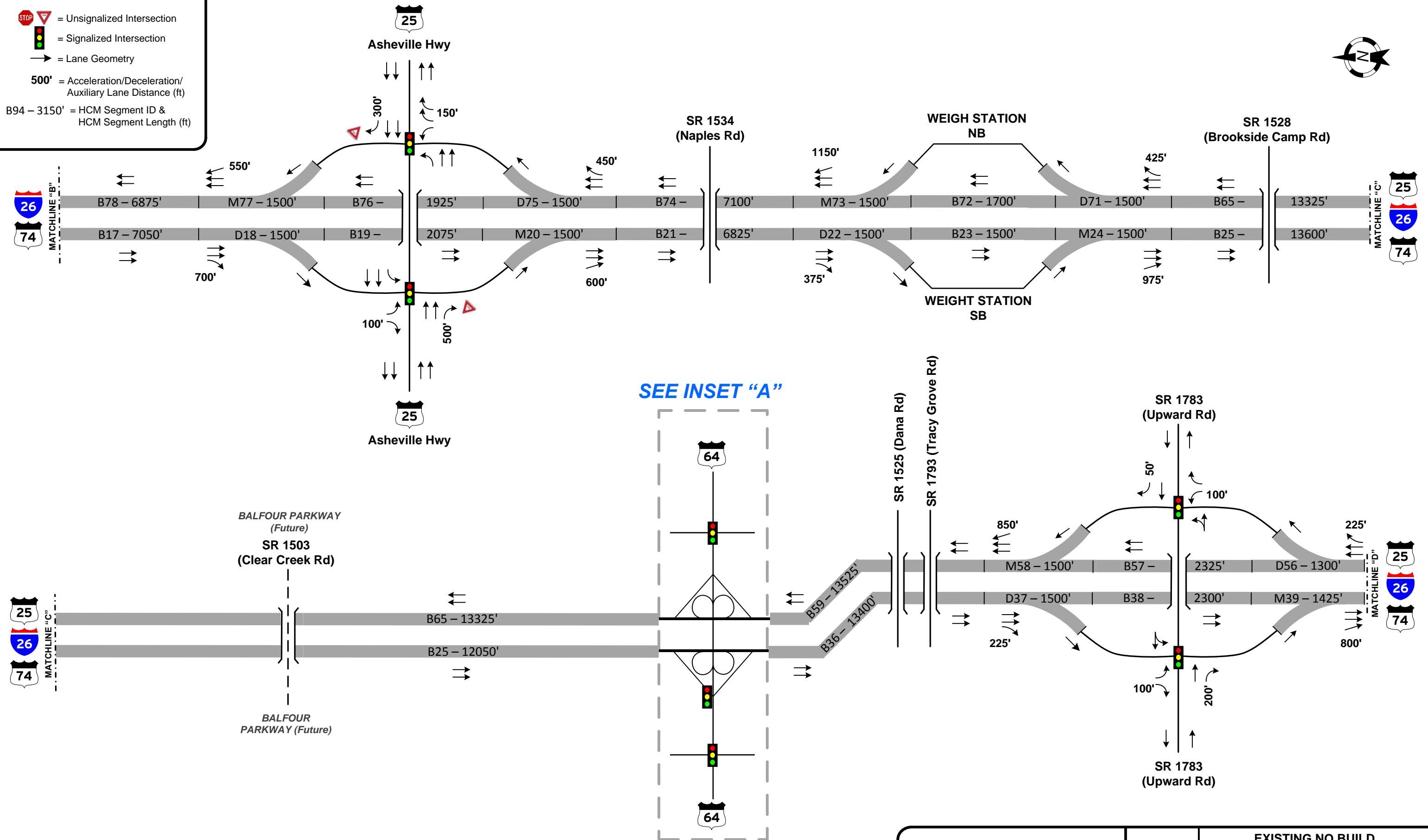

SEE INSET "A"

S.T.I.P. I-4400/I-4700 I-26 WIDENING BUNCOMBE AND HENDERSON COUNTIES	NOT TO SCALE	EXISTING NO BUILD LANEAGE & HCM SEGMENT ID#	
		DATE: September 2013	FIGURE 2.2

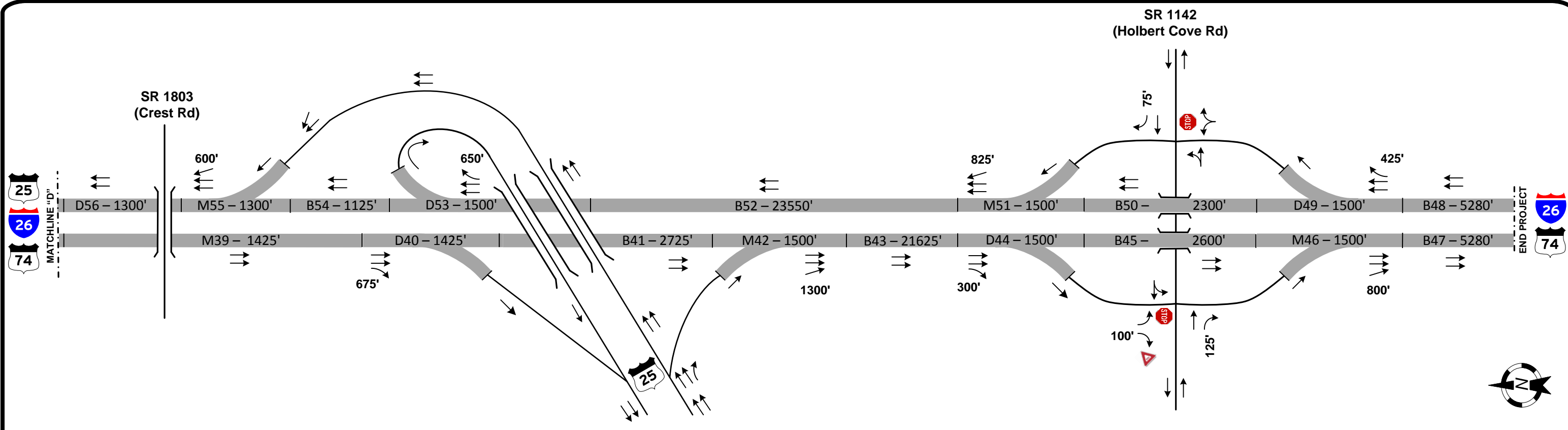

INSET "A"
I-26/US 64
INTERCHANGE

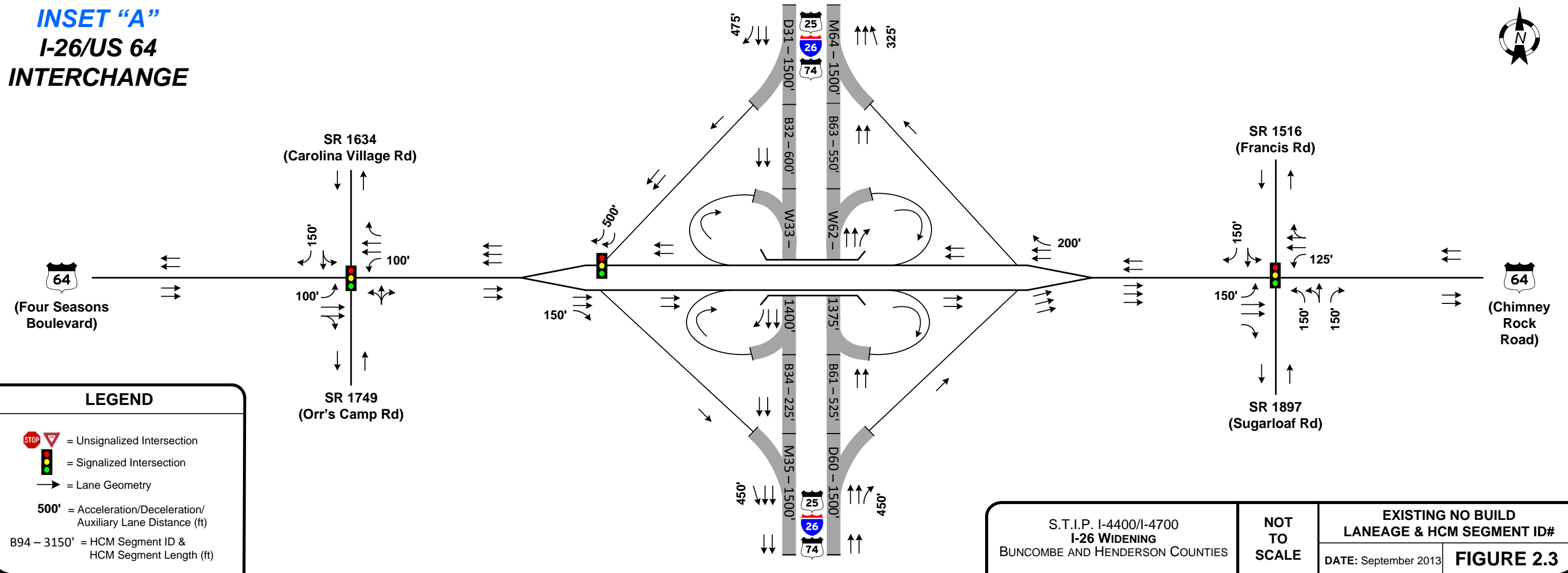

LEGEND

- = Unsignalized Intersection
- = Signalized Intersection
- = Lane Geometry
- 500' = Acceleration/Deceleration/Auxiliary Lane Distance (ft)
- B94 - 3150' = HCM Segment ID & HCM Segment Length (ft)

S.T.I.P. I-4400/I-4700 I-26 WIDENING BUNCOMBE AND HENDERSON COUNTIES	NOT TO SCALE	EXISTING NO BUILD LANEAGE & HCM SEGMENT ID#	
		DATE: September 2013	FIGURE 2.3

LEGEND

XX (XX) = AM (PM) Peak Hour Volumes

= Unsignalized Intersection

= Signalized Intersection

= Lane Geometry

AM (PM) Peak Hour Level of Service

- LOS A - D

- LOS E

- LOS F

- Not Analyzed

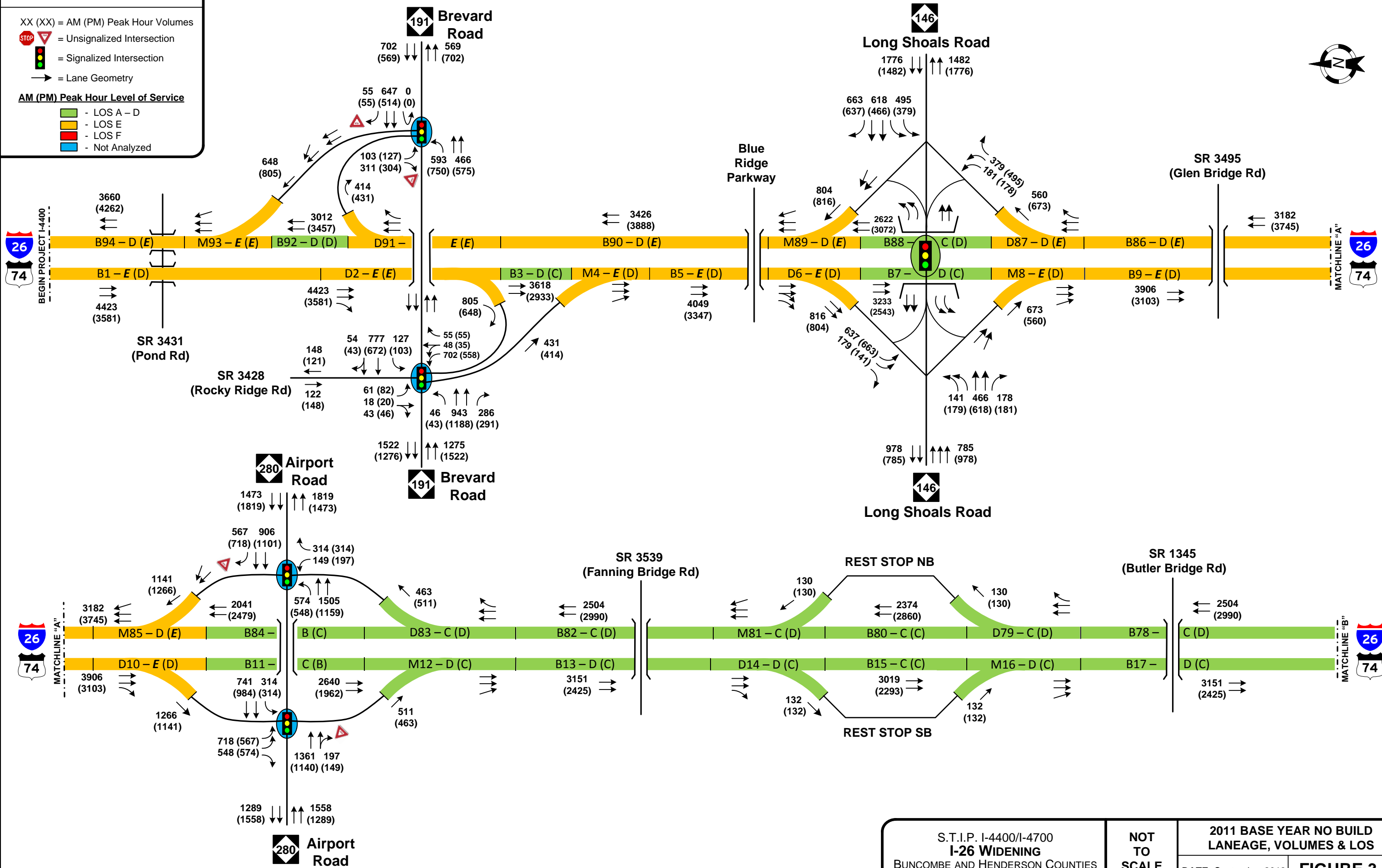

LEGEND

- XX (XX) = AM (PM) Peak Hour Volumes
- = Unsignalized Intersection
- = Signalized Intersection
- = Lane Geometry
- AM (PM) Peak Hour Level of Service**
- LOS A - D
- LOS E
- LOS F
- Not Analyzed

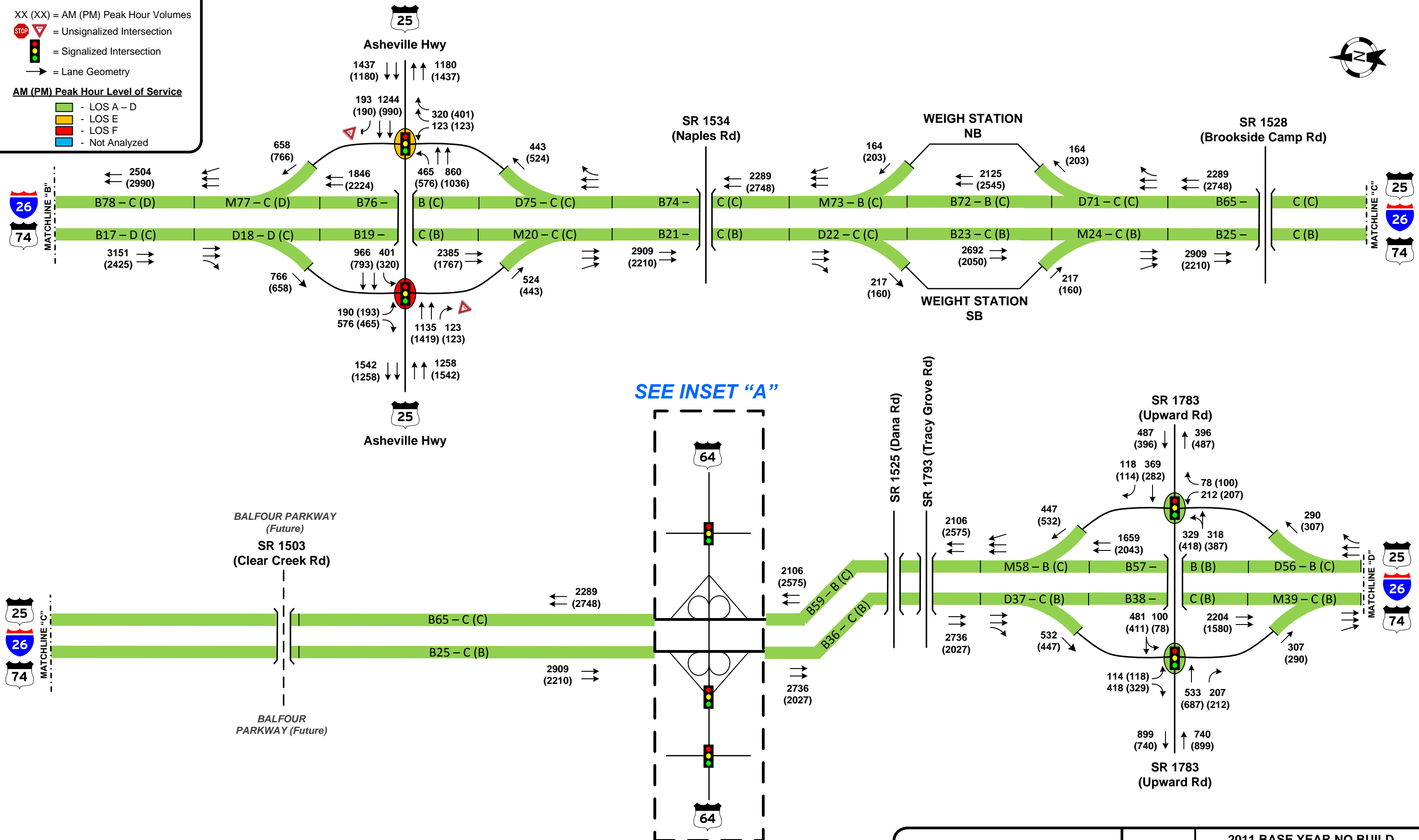

SEE INSET "A"

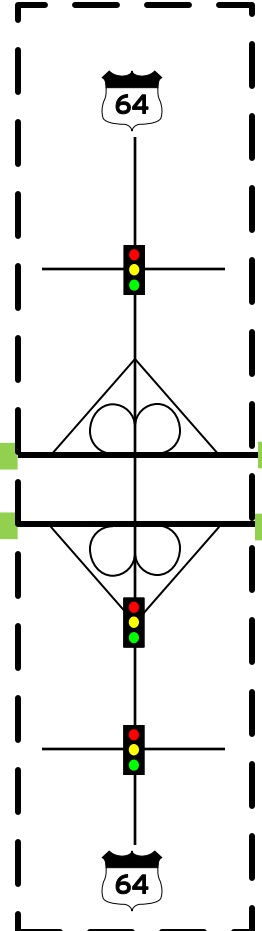

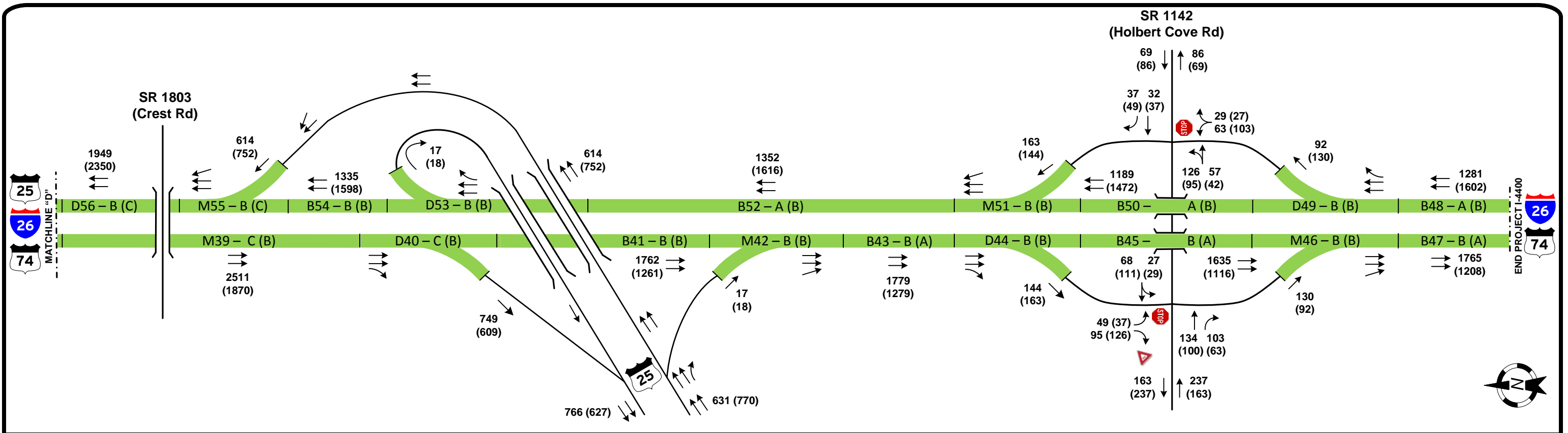

INSET "A"
I-26/US 64
INTERCHANGE

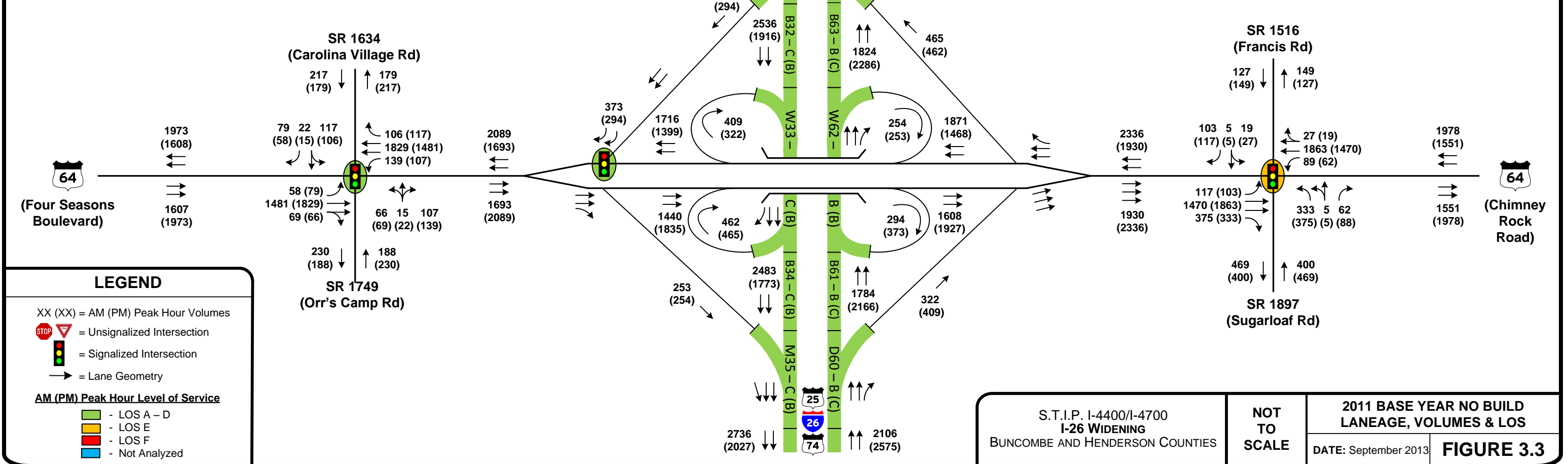

LEGEND

XX (XX) = AM (PM) Peak Hour Volumes

= Unsignalized Intersection

= Signalized Intersection

= Lane Geometry

AM (PM) Peak Hour Level of Service

- LOS A - D

- LOS E

- LOS F

- Not Analyzed

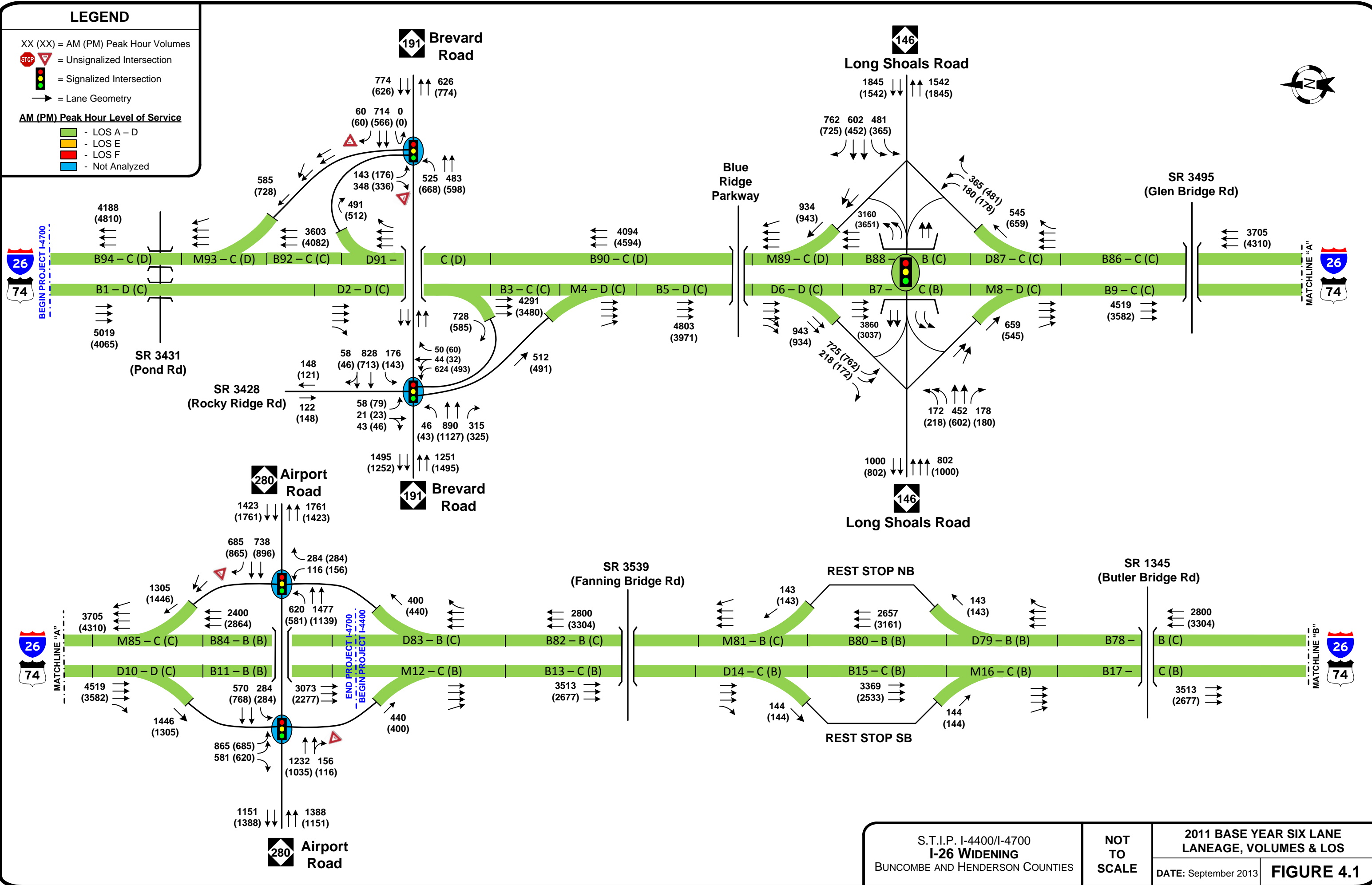

S.T.I.P. I-4400/I-4700
I-26 WIDENING
 BUNCOMBE AND HENDERSON COUNTIES

NOT TO SCALE

2011 BASE YEAR SIX LANE LANEAGE, VOLUMES & LOS
 DATE: September 2013 **FIGURE 4.1**

LEGEND

XX (XX) = AM (PM) Peak Hour Volumes

 = Unsignalized Intersection

 = Signalized Intersection

 = Lane Geometry

AM (PM) Peak Hour Level of Service

 - LOS A - D

 - LOS E

 - LOS F

 - Not Analyzed

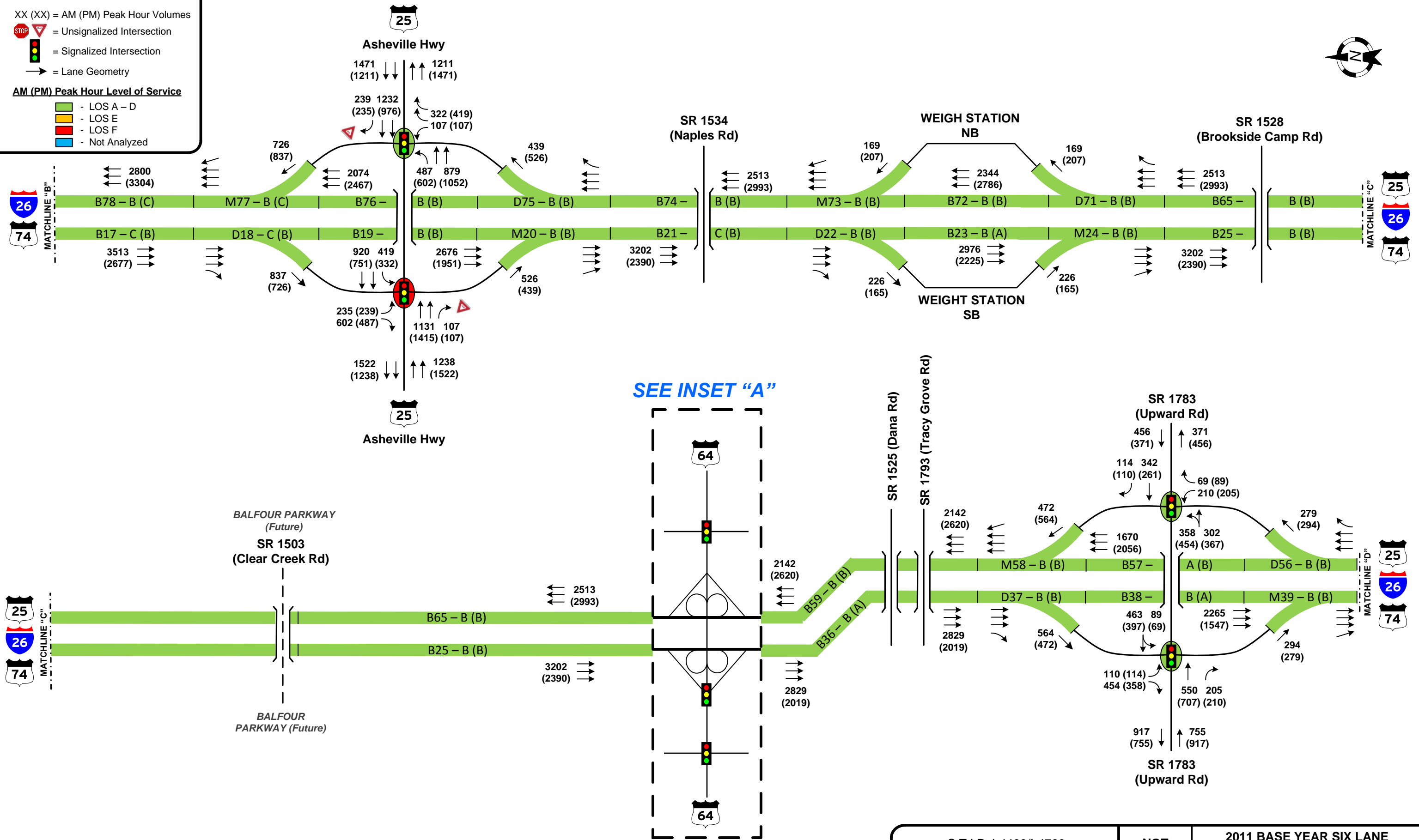

SEE INSET "A"

S.T.I.P. I-4400/I-4700 I-26 WIDENING BUNCOMBE AND HENDERSON COUNTIES	NOT TO SCALE	2011 BASE YEAR SIX LANE LANEAGE, VOLUMES & LOS	
		DATE: September 2013	FIGURE 4.2

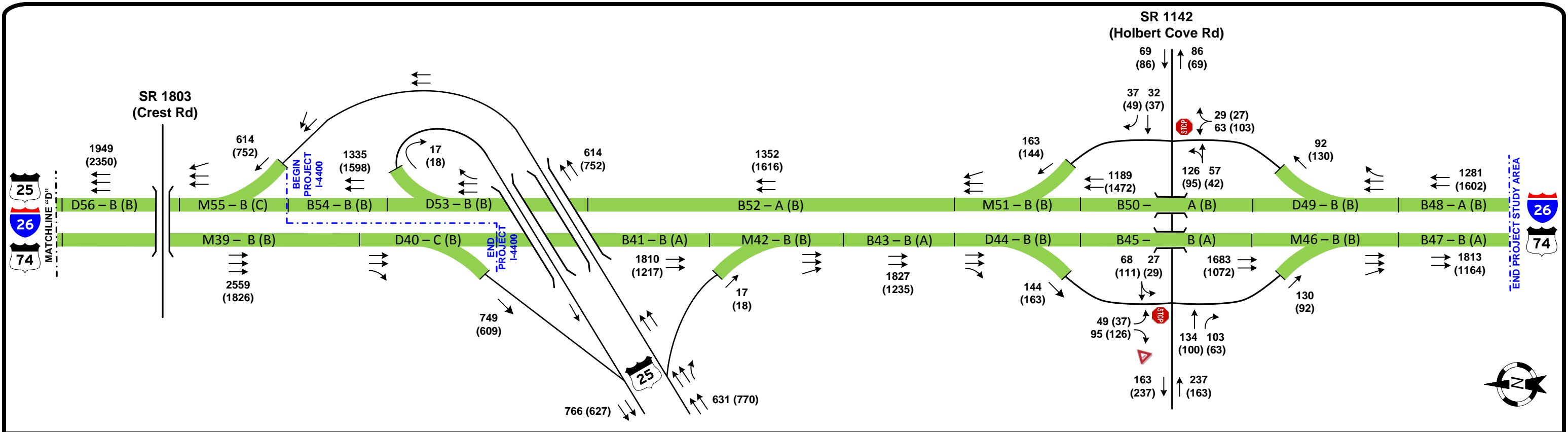

INSET "A"
I-26/US 64
INTERCHANGE

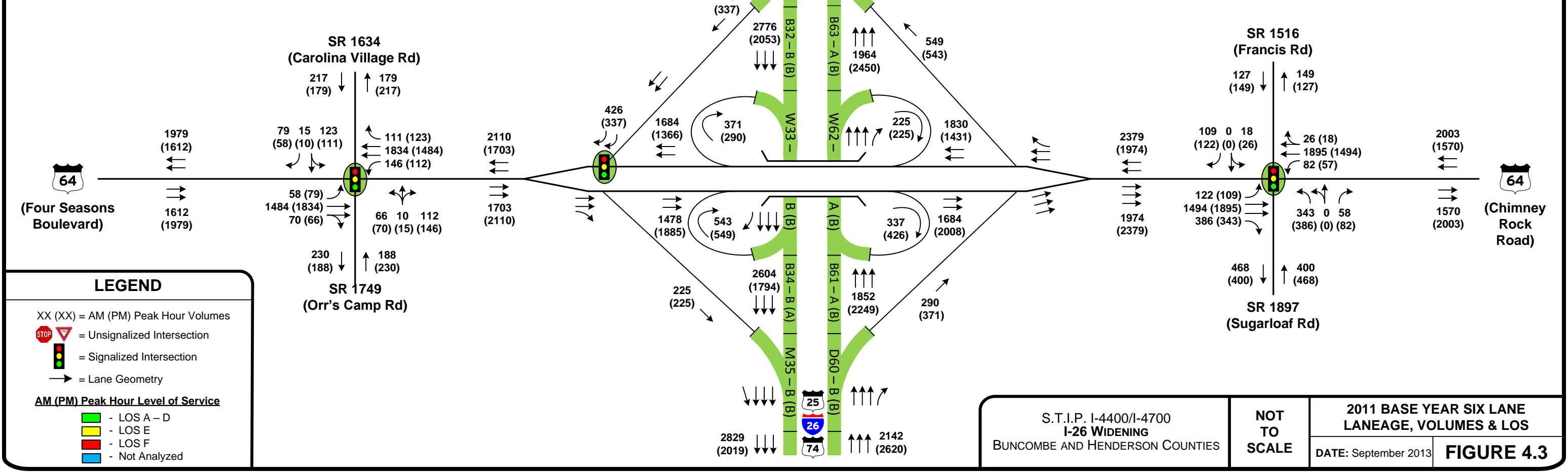

LEGEND

XX (XX) = AM (PM) Peak Hour Volumes

= Unsignalized Intersection

= Signalized Intersection

= Lane Geometry

AM (PM) Peak Hour Level of Service

- LOS A - D

- LOS E

- LOS F

- Not Analyzed

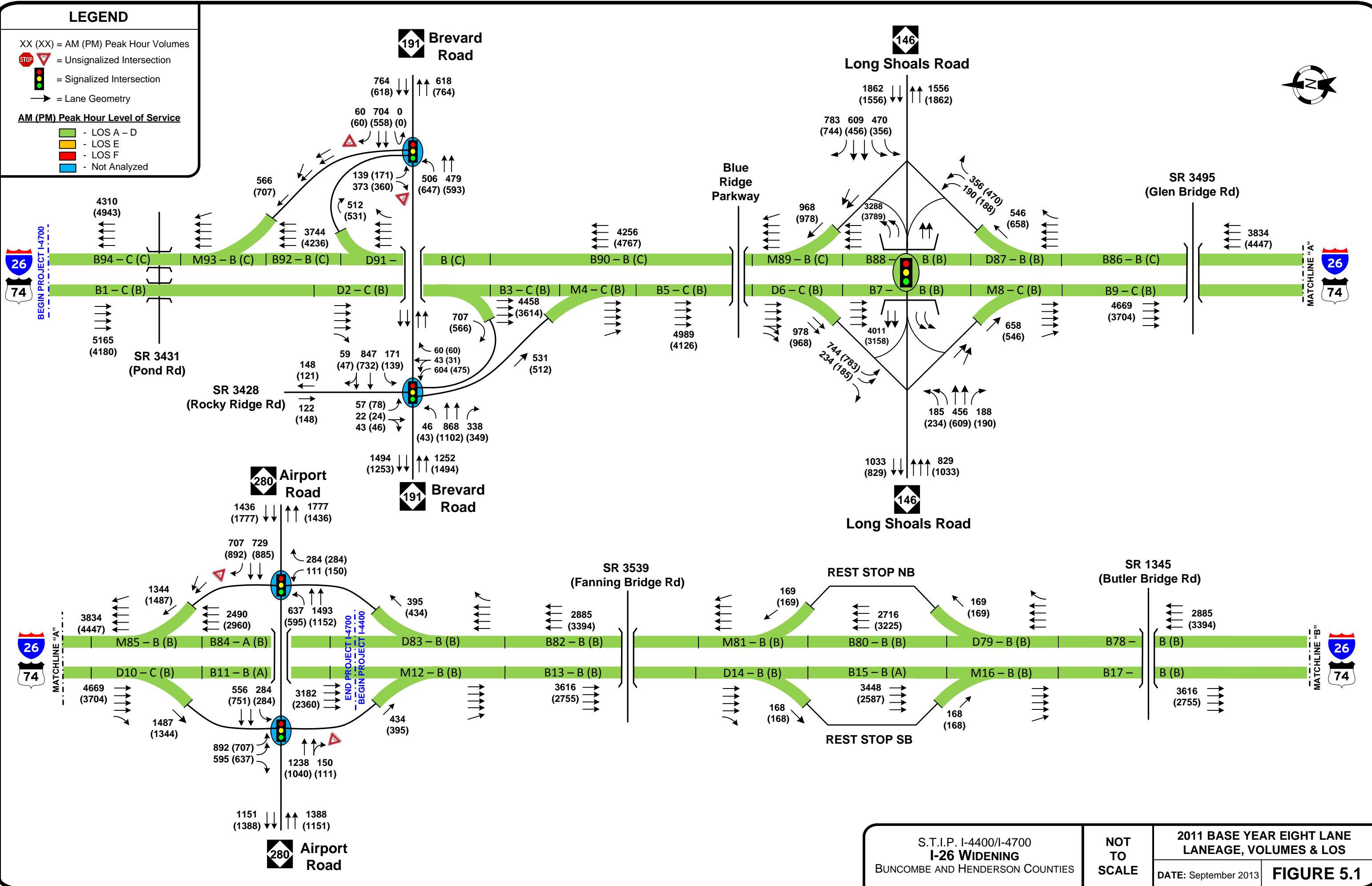

S.T.I.P. I-4400/I-4700
I-26 WIDENING
 BUNCOMBE AND HENDERSON COUNTIES

NOT TO SCALE

2011 BASE YEAR EIGHT LANE LANEAGE, VOLUMES & LOS
 DATE: September 2013 **FIGURE 5.1**

LEGEND

- XX (XX) = AM (PM) Peak Hour Volumes
- = Unsignalized Intersection
- = Signalized Intersection
- = Lane Geometry
- AM (PM) Peak Hour Level of Service**
- LOS A - D
- LOS E
- LOS F
- Not Analyzed

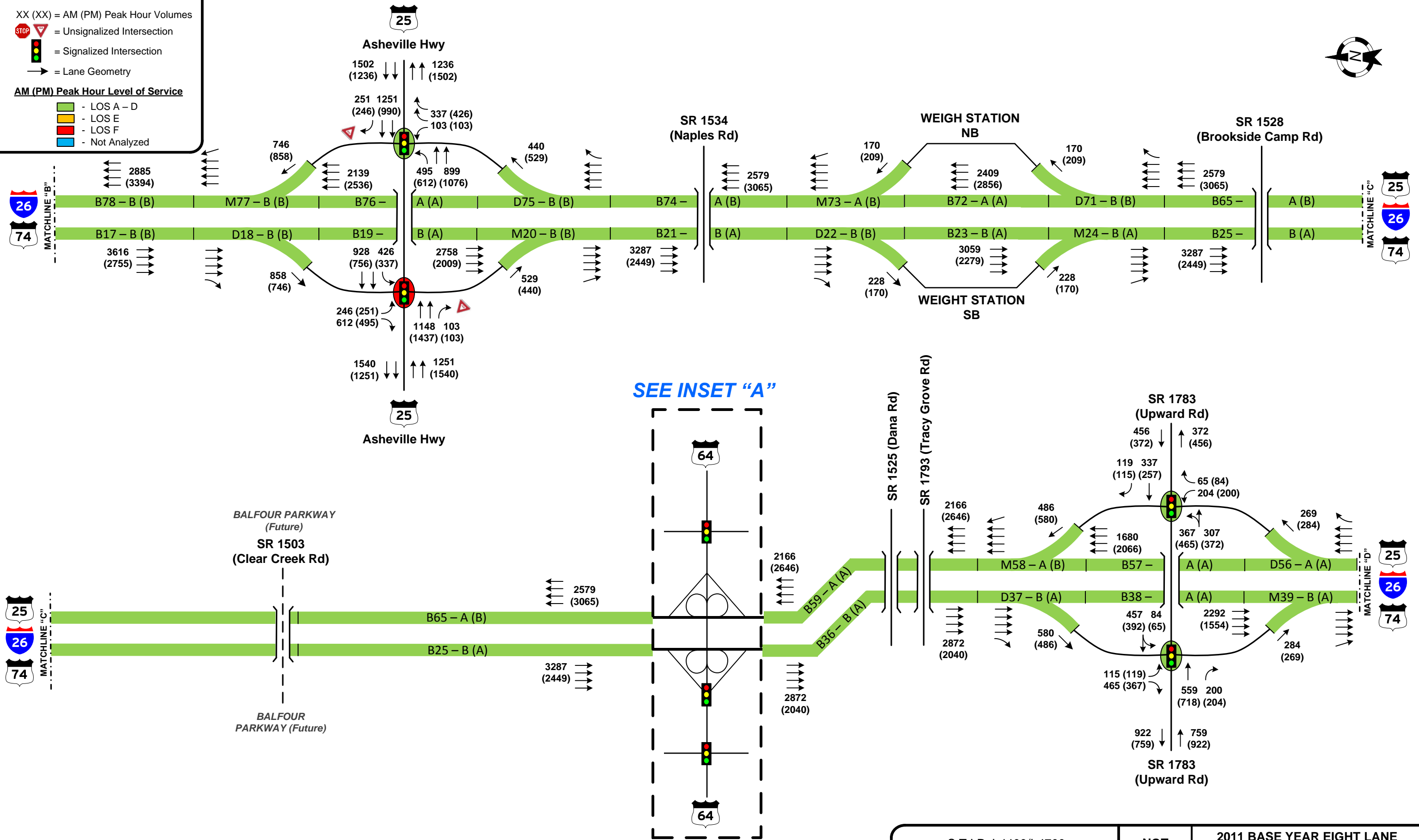

SEE INSET "A"

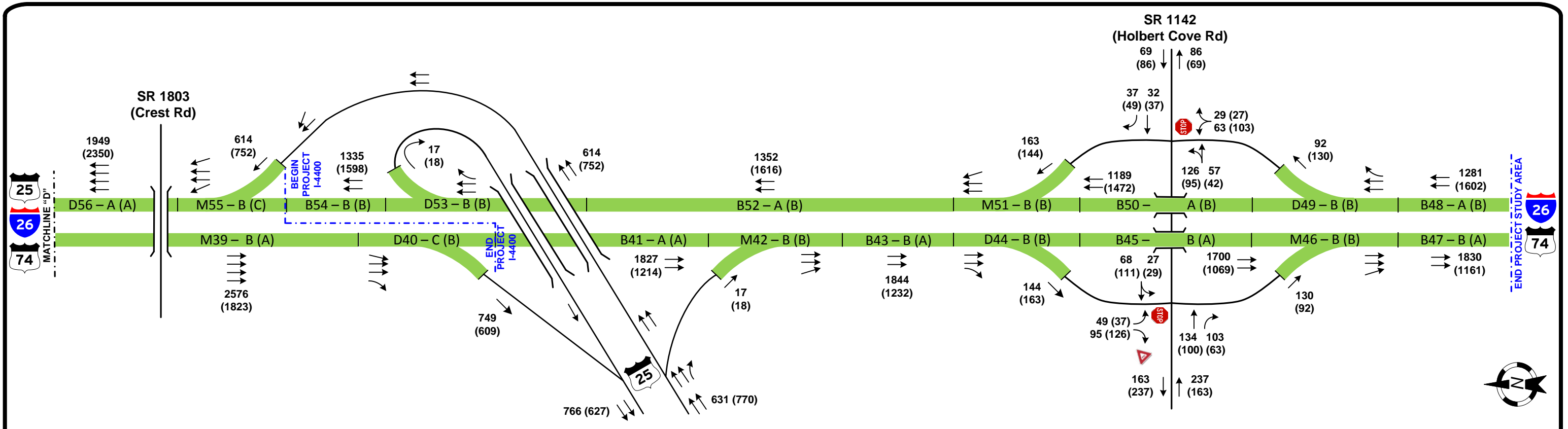

INSET "A"
I-26/US 64
INTERCHANGE

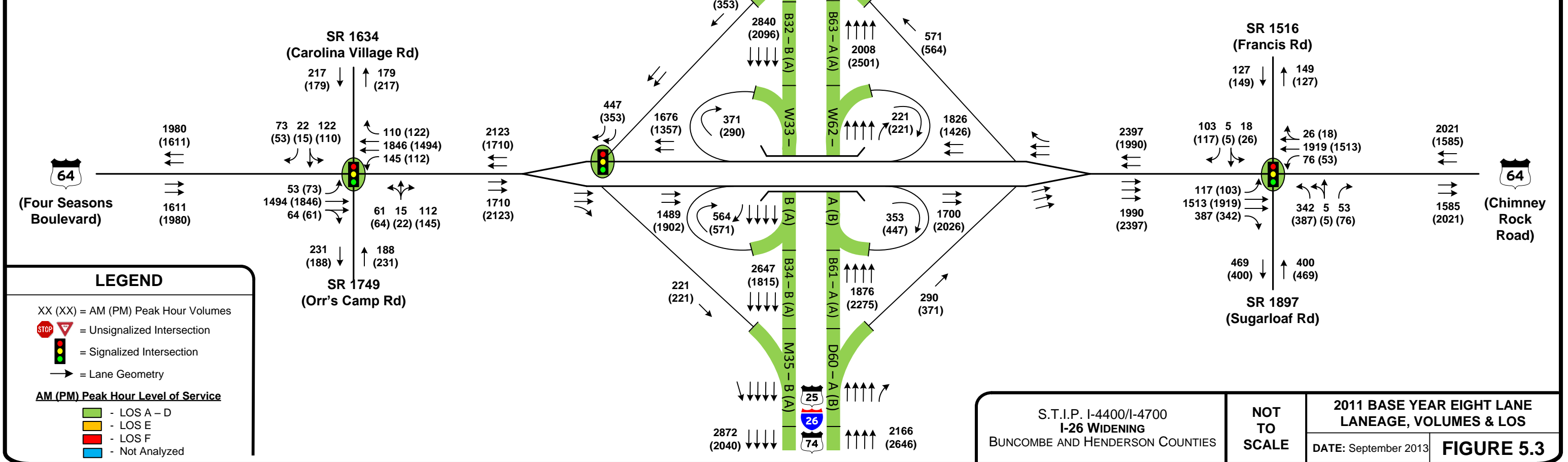

LEGEND





- XX (XX) = AM (PM) Peak Hour Volumes
- = Unsignalized Intersection
- = Signalized Intersection
- = Lane Geometry
- AM (PM) Peak Hour Level of Service**
- LOS A - D
- LOS E
- LOS F
- Not Analyzed

S.T.I.P. I-4400/I-4700
I-26 WIDENING
BUNCOMBE AND HENDERSON COUNTIES

NOT TO SCALE

2011 BASE YEAR EIGHT LANE LANEAGE, VOLUMES & LOS
DATE: September 2013 **FIGURE 5.3**

LEGEND

-  = Unsignalized Intersection
-  = Signalized Intersection
-  = Lane Geometry
- 500' = Acceleration/Deceleration/Auxiliary Lane Distance (ft)
- B94 - 3150' = HCM Segment ID & HCM Segment Length (ft)
-   = New/Improved Facility

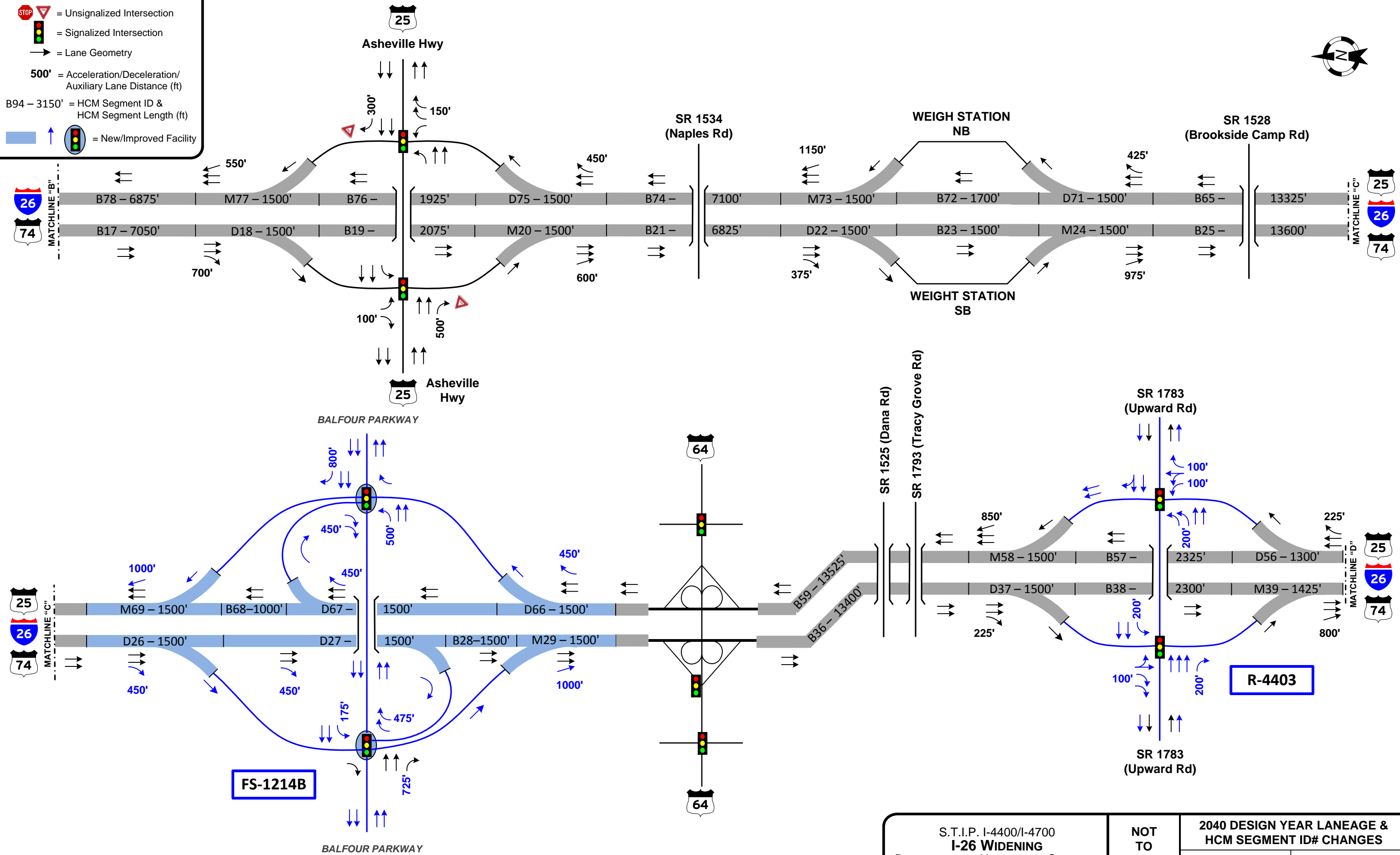

FS-1214B

R-4403

S.T.I.P. I-4400/I-4700 I-26 WIDENING BUNCOMBE AND HENDERSON COUNTIES	NOT TO SCALE	2040 DESIGN YEAR LANEAGE & HCM SEGMENT ID# CHANGES DATE: September 2013
		FIGURE 6.1

I-26/NC 280 INTERCHANGE DETAIL



NOT
TO
SCALE

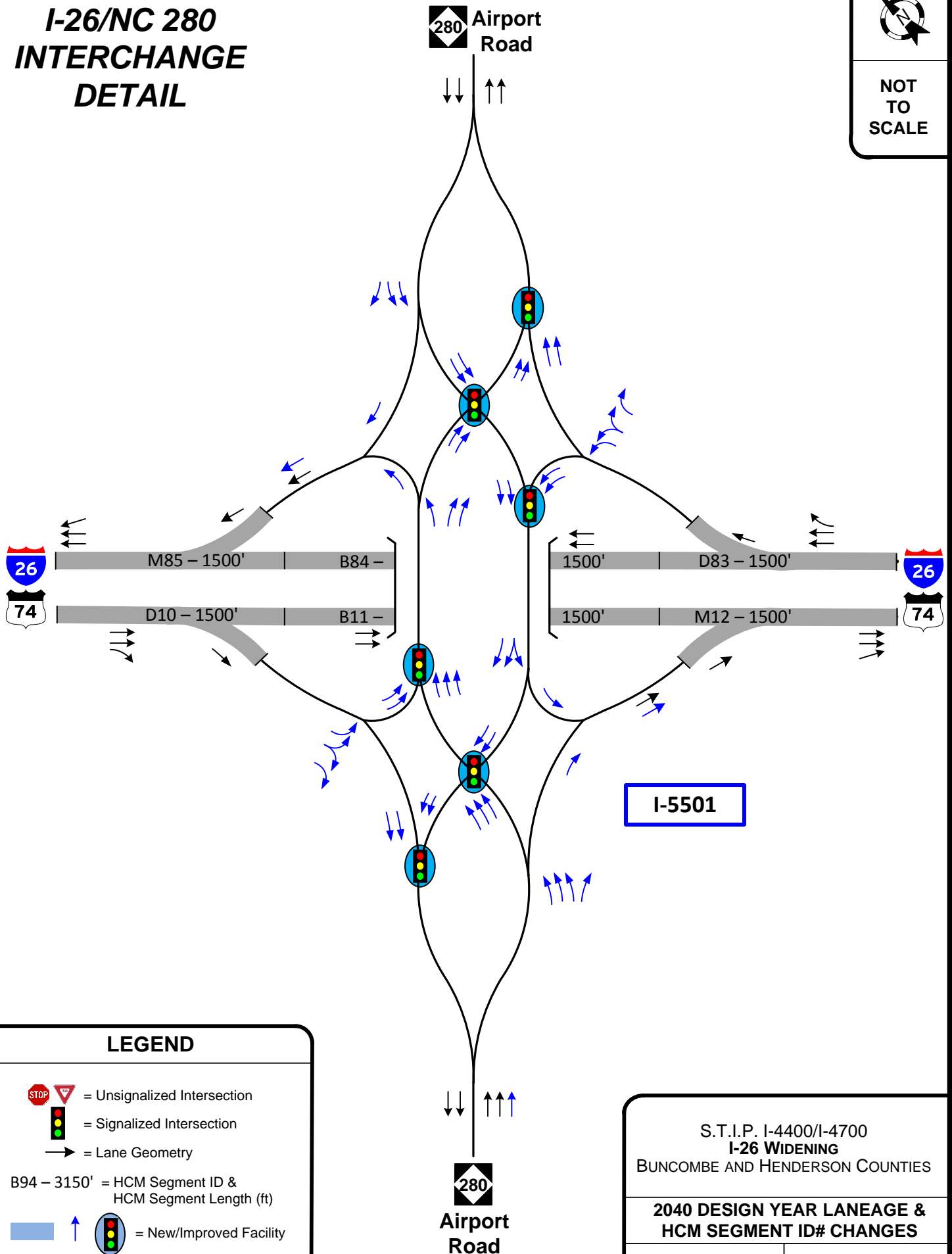

LEGEND

- = Unsignalized Intersection
- = Signalized Intersection
- = Lane Geometry
- B94 - 3150' = HCM Segment ID & HCM Segment Length (ft)
- = New/Improved Facility

S.T.I.P. I-4400/I-4700
I-26 WIDENING
BUNCOMBE AND HENDERSON COUNTIES

2040 DESIGN YEAR LANEAGE &
HCM SEGMENT ID# CHANGES

DATE: September 2013 **FIGURE 6.2**

LEGEND

XX (XX) = AM (PM) Peak Hour Volumes

= Unsignalized Intersection

= Signalized Intersection

= Lane Geometry

AM (PM) Peak Hour Level of Service

- LOS A - D

- LOS E

- LOS F

- Not Analyzed

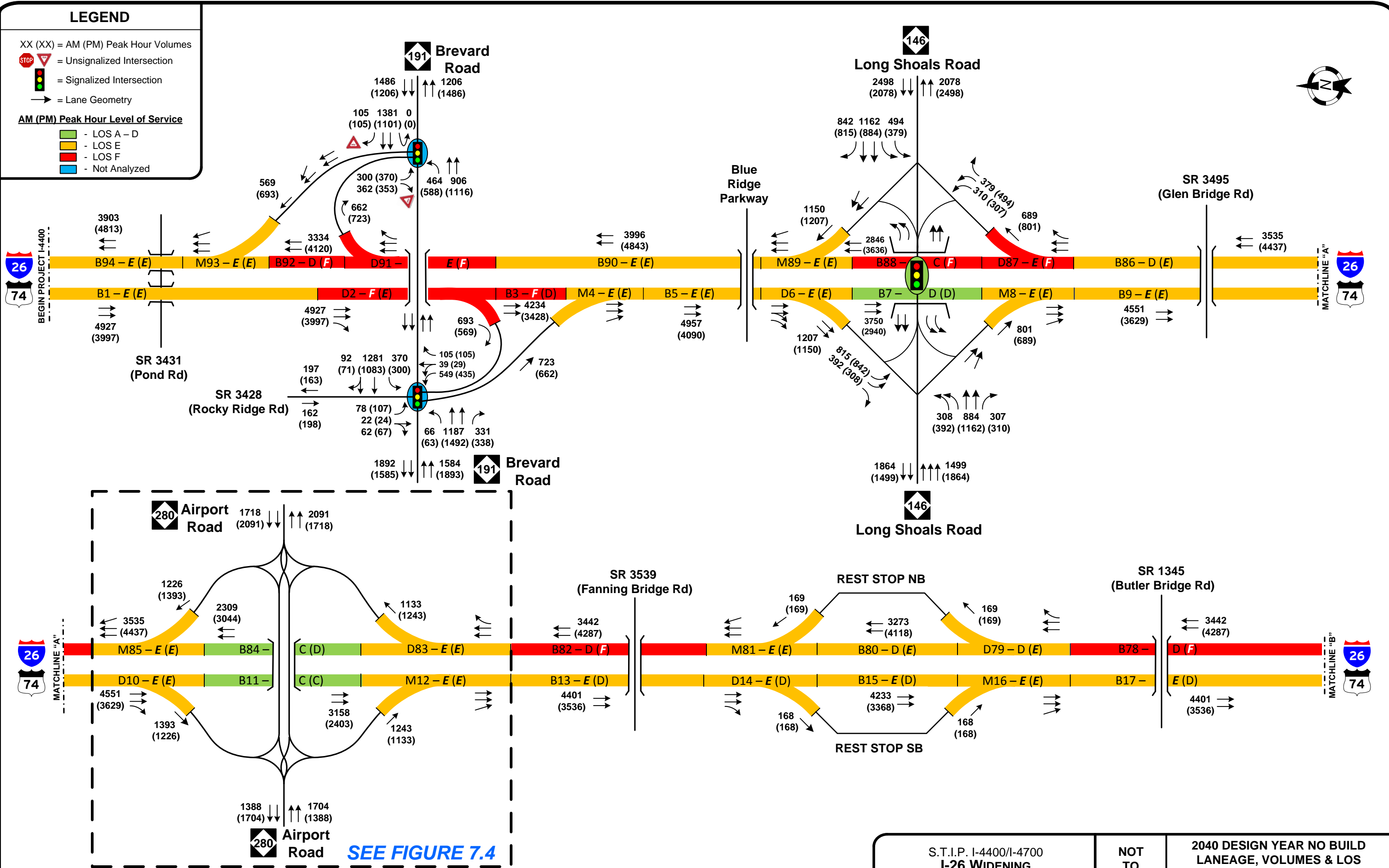

SEE FIGURE 7.4

S.T.I.P. I-4400/I-4700 I-26 WIDENING BUNCOMBE AND HENDERSON COUNTIES	NOT TO SCALE	2040 DESIGN YEAR NO BUILD LANEAGE, VOLUMES & LOS	
		DATE: September 2013	FIGURE 7.1

LEGEND

- XX (XX) = AM (PM) Peak Hour Volumes
- = Unsignalized Intersection
- = Signalized Intersection
- = Lane Geometry
- AM (PM) Peak Hour Level of Service**
- LOS A - D
- LOS E
- LOS F
- Not Analyzed

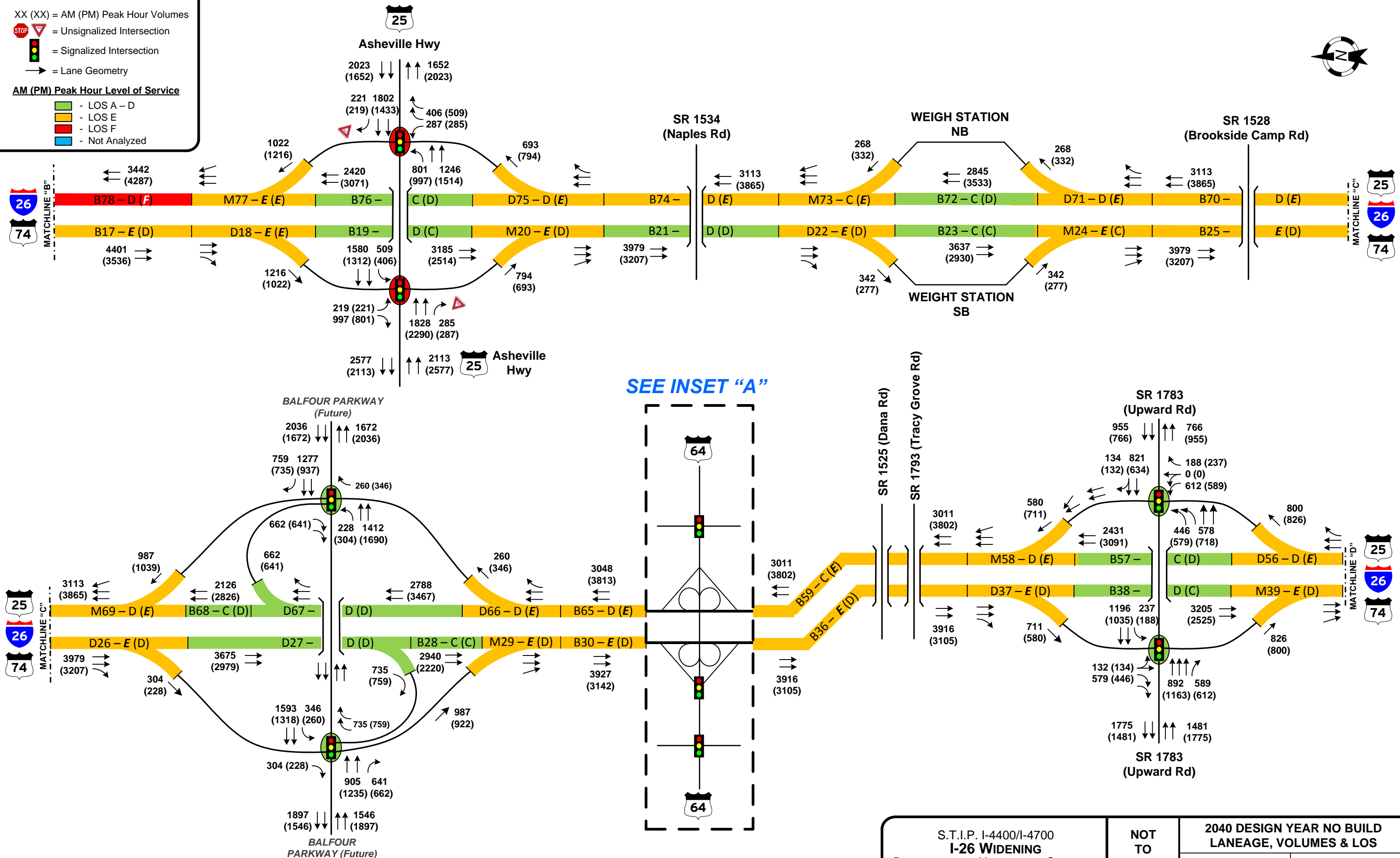

SEE INSET "A"

S.T.I.P. I-4400/I-4700 I-26 WIDENING BUNCOMBE AND HENDERSON COUNTIES	NOT TO SCALE	2040 DESIGN YEAR NO BUILD LANEAGE, VOLUMES & LOS DATE: September 2013	FIGURE 7.2
---	--------------------	---	-------------------

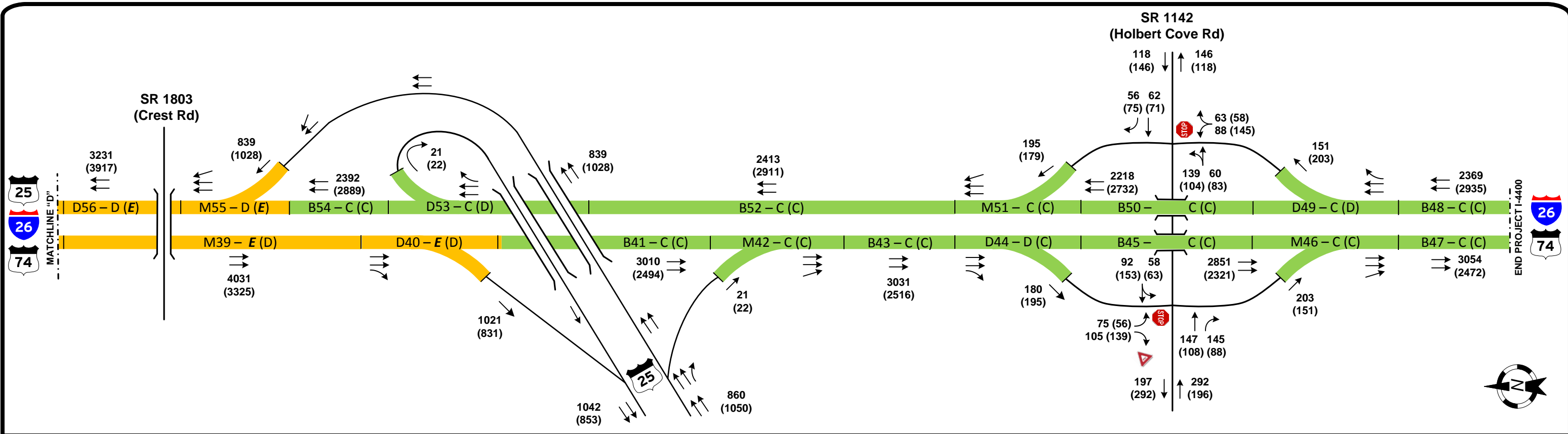

INSET "A"
I-26/US 64
INTERCHANGE

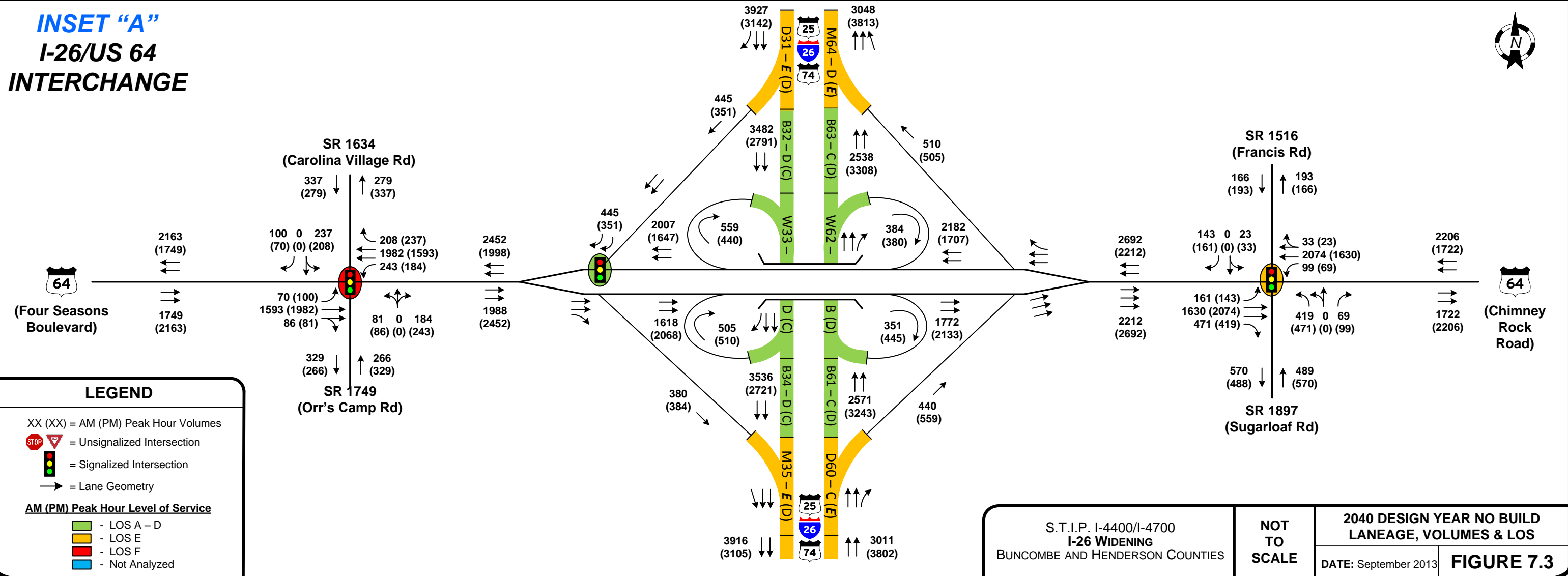

LEGEND

- XX (XX) = AM (PM) Peak Hour Volumes
- = Unsignalized Intersection
- = Signalized Intersection
- = Lane Geometry
- AM (PM) Peak Hour Level of Service**
- LOS A - D
- LOS E
- LOS F
- Not Analyzed

S.T.I.P. I-4400/I-4700 I-26 WIDENING BUNCOMBE AND HENDERSON COUNTIES	NOT TO SCALE	2040 DESIGN YEAR NO BUILD LANEAGE, VOLUMES & LOS	
		DATE: September 2013	FIGURE 7.3

I-26/NC 280 INTERCHANGE DETAIL

NOT TO SCALE

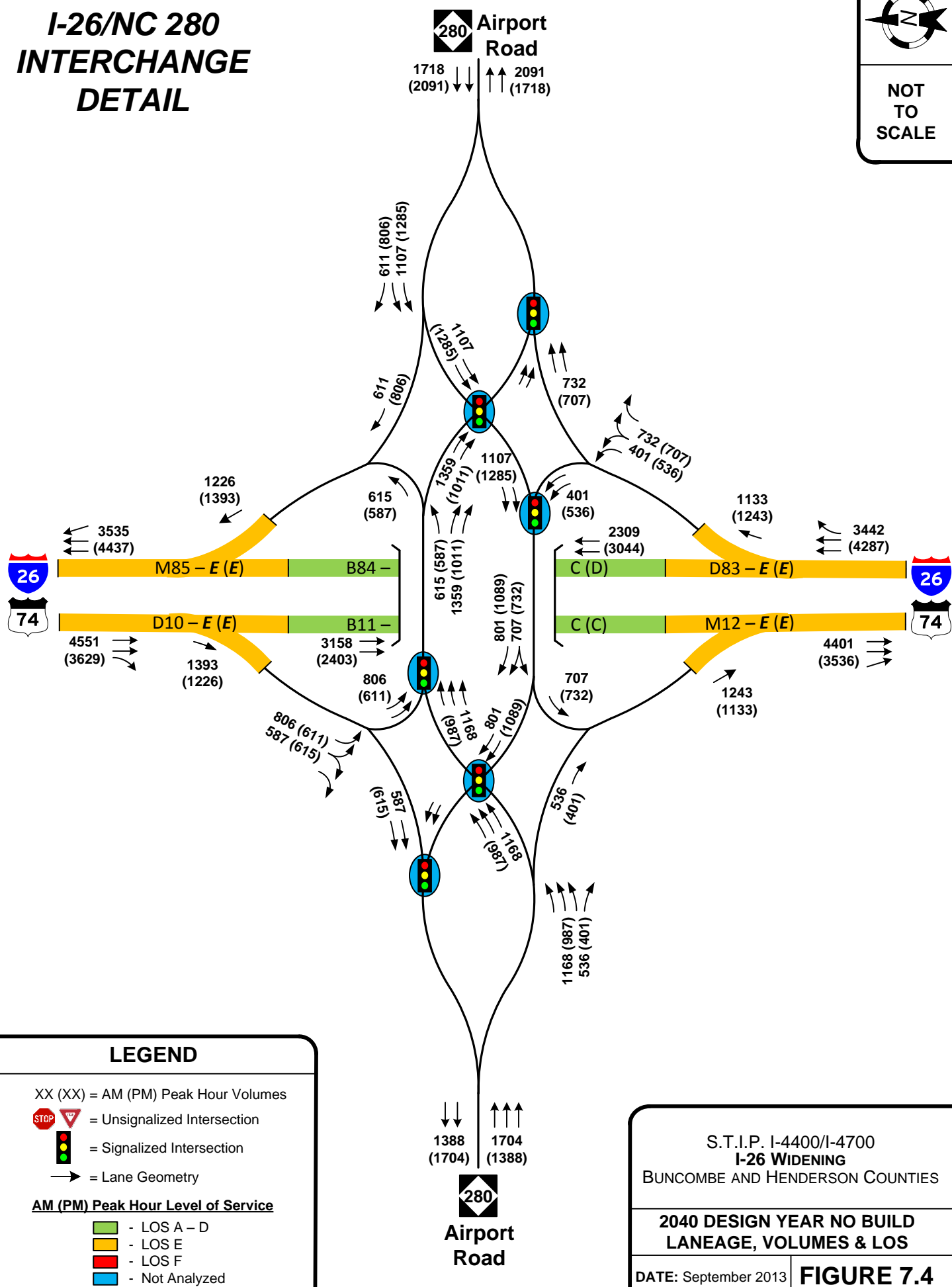

LEGEND

- XX (XX) = AM (PM) Peak Hour Volumes
 - = Unsignalized Intersection
 - = Signalized Intersection
 - = Lane Geometry
- AM (PM) Peak Hour Level of Service**
- LOS A - D
 - LOS E
 - LOS F
 - Not Analyzed

S.T.I.P. I-4400/I-4700
I-26 WIDENING
 BUNCOMBE AND HENDERSON COUNTIES

2040 DESIGN YEAR NO BUILD LANEAGE, VOLUMES & LOS

DATE: September 2013 **FIGURE 7.4**

LEGEND

XX (XX) = AM (PM) Peak Hour Volumes

= Unsignalized Intersection

= Signalized Intersection

= Lane Geometry

AM (PM) Peak Hour Level of Service

- LOS A - D

- LOS E

- LOS F

- Not Analyzed

191 Brevard Road

146 Long Shoals Road

1501 (1220) ↓↑ 1220 (1501)

2591 (2147) ↓↑ 2147 (2591)

125 1376 0 (125) (1095) (0)

859 1142 590 (829) (864) (454)

349 (430) 464 (588) 871 (1071)
357 (347)

454 (590) 386 (380) 840 (970)

706 (777)

1184 (1244) 3751 (4599)

589 (713)

4935 (5843)

4229 (5066)

1244 (1184) 829 (859) 415 (325)

5949 (4835)

1943 (1569) 1569 (1943)

713 (589)

325 864 380 (415) (1142) (386)

5236 (4246)

1244 (1184) 829 (859) 415 (325)

777 (706)

970 (840)

125 (125) 39 (28) 549 (436)

4769 (3768)

197 (162) 87 (67) 1216 (1026) 430 (349)

71 1135 326 (67) (1433) (333)

163 (197) 75 (101) 21 (24) 67 (72)

1943 (1569) 1569 (1943)

1832 (1534) 1532 (1833)

1943 (1569) 1569 (1943)

191 Brevard Road

146 Long Shoals Road

280 Airport Road

1627 (1993) ↓↑ 1993 (1627)

1408 (1574)

3183 (3995)

1056 (1167)

4591 (5569)

5739 (4608)

1574 (1408)

4165 (3200)

1167 (1056)

1417 (1728) ↓↑ 1728 (1417)

280 Airport Road

SR 3539 (Fanning Bridge Rd)

REST STOP NB

SR 1345 (Butler Bridge Rd)

REST STOP SB

4239 (5162)

208 (208)

4031 (4954)

208 (208)

5332 (4256)

204 (204)

5128 (4052)

204 (204)

4239 (5162)

4239 (5162)

5332 (4256)

5332 (4256)

SEE FIGURE 8.4

S.T.I.P. I-4400/I-4700
I-26 WIDENING
BUNCOMBE AND HENDERSON COUNTIES

NOT TO SCALE

2040 DESIGN YEAR SIX LANE LANEAGE, VOLUMES & LOS

DATE: September 2013

FIGURE 8.1

LEGEND

XX (XX) = AM (PM) Peak Hour Volumes

= Unsignalized Intersection

= Signalized Intersection

= Lane Geometry

AM (PM) Peak Hour Level of Service

- LOS A - D
- LOS E
- LOS F
- Not Analyzed

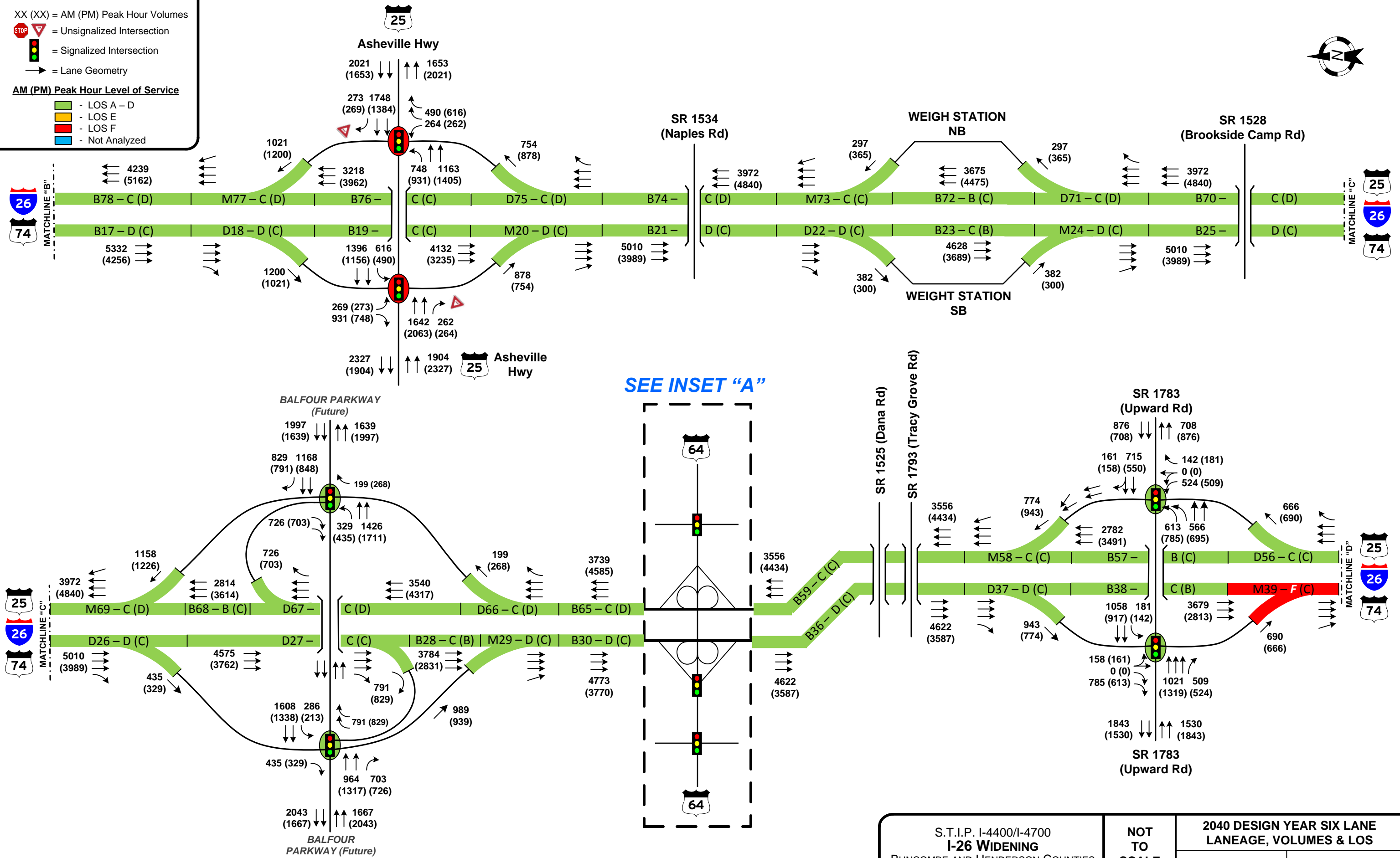

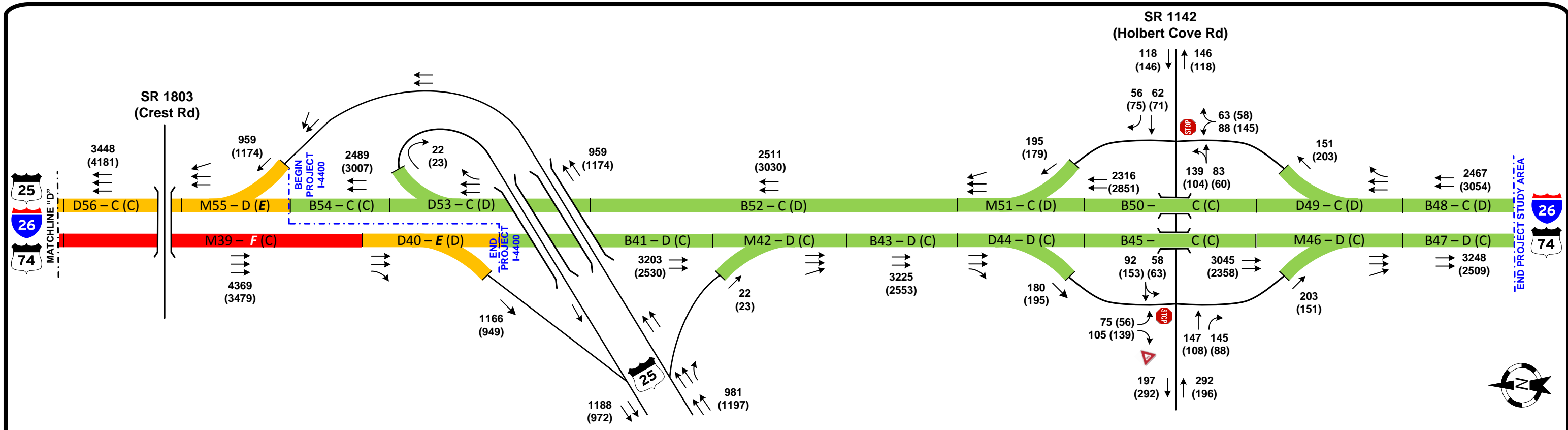

INSET "A"
I-26/US 64
INTERCHANGE

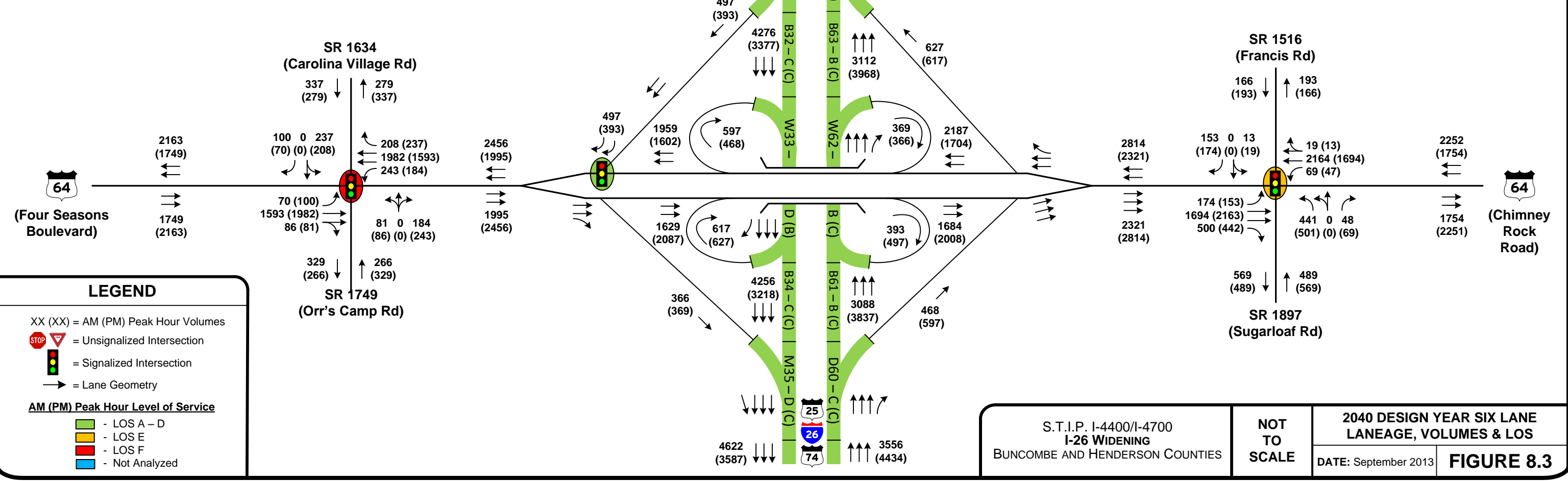

LEGEND

- XX (XX) = AM (PM) Peak Hour Volumes
- = Unsignalized Intersection
- = Signalized Intersection
- = Lane Geometry
- AM (PM) Peak Hour Level of Service**
- LOS A - D
- LOS E
- LOS F
- Not Analyzed

S.T.I.P. I-4400/I-4700
I-26 WIDENING
 BUNCOMBE AND HENDERSON COUNTIES

NOT TO SCALE

2040 DESIGN YEAR SIX LANE LANEAGE, VOLUMES & LOS
 DATE: September 2013 **FIGURE 8.3**

I-26/NC 280 INTERCHANGE DETAIL



NOT
TO
SCALE

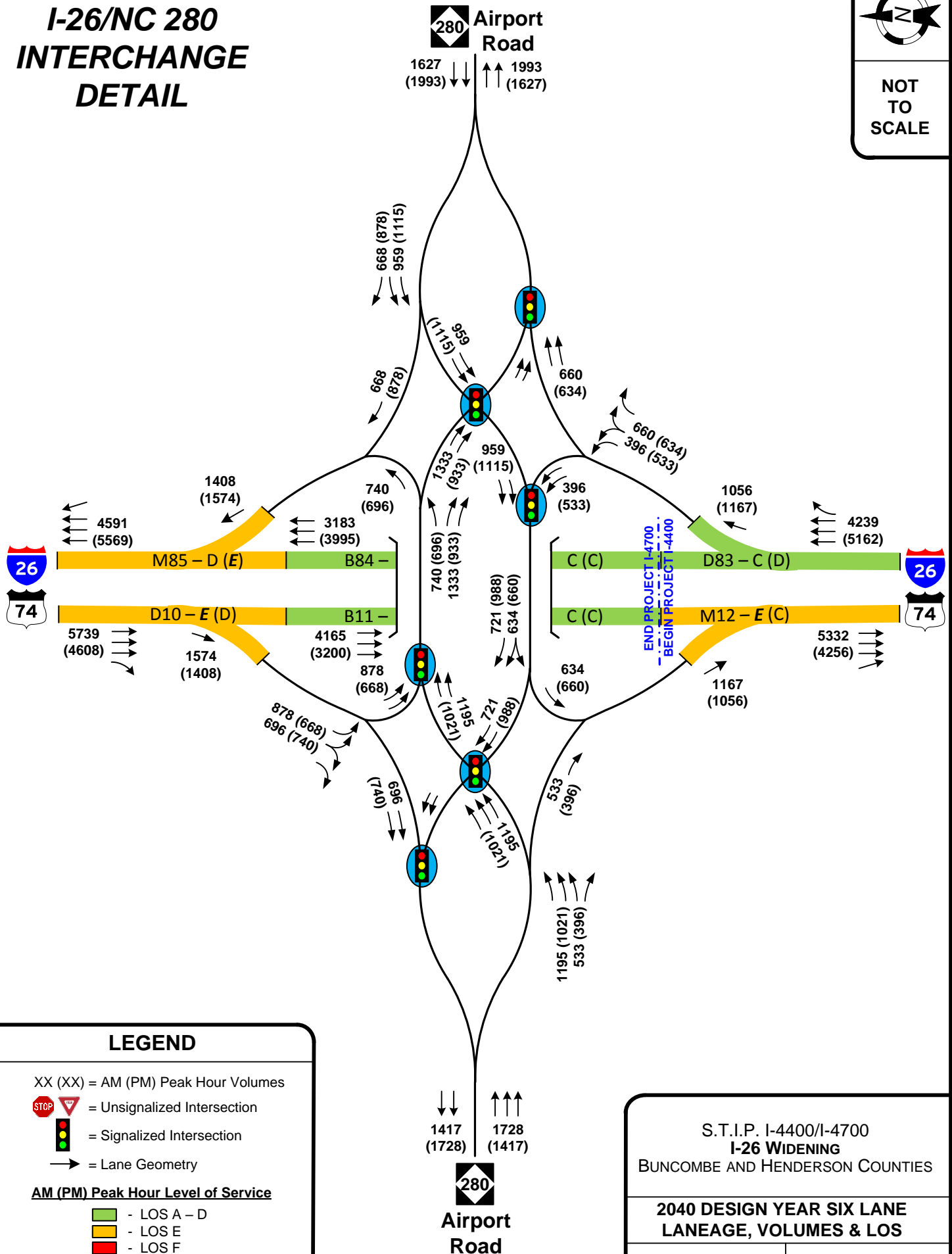

LEGEND

XX (XX) = AM (PM) Peak Hour Volumes

= Unsignalized Intersection

= Signalized Intersection

= Lane Geometry

AM (PM) Peak Hour Level of Service

- LOS A - D

- LOS E

- LOS F

- Not Analyzed

191 Brevard Road

146 Long Shoals Road

191 Brevard Road

146 Long Shoals Road

280 Airport Road

SR 3539 (Fanning Bridge Rd)

SR 1345 (Butler Bridge Rd)

SEE FIGURE 9.4

S.T.I.P. I-4400/I-4700 I-26 WIDENING BUNCOMBE AND HENDERSON COUNTIES		NOT TO SCALE	2040 DESIGN YEAR EIGHT LANE LANEAGE, VOLUMES & LOS
			DATE: September 2013 FIGURE 9.1

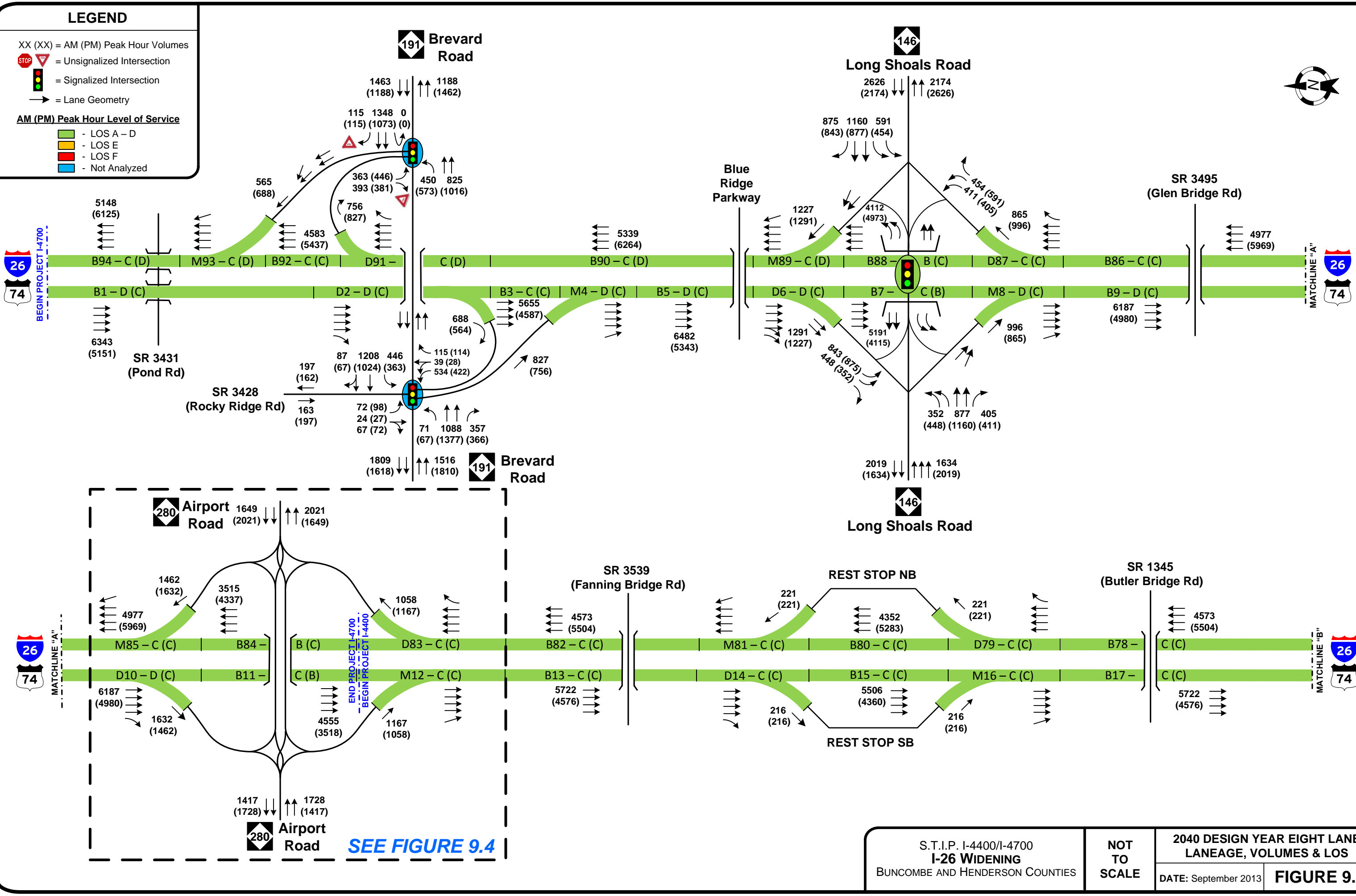

LEGEND

- XX (XX) = AM (PM) Peak Hour Volumes
 - = Unsignalized Intersection
 - = Signalized Intersection
 - = Lane Geometry
- AM (PM) Peak Hour Level of Service**
- LOS A - D
 - LOS E
 - LOS F
 - Not Analyzed

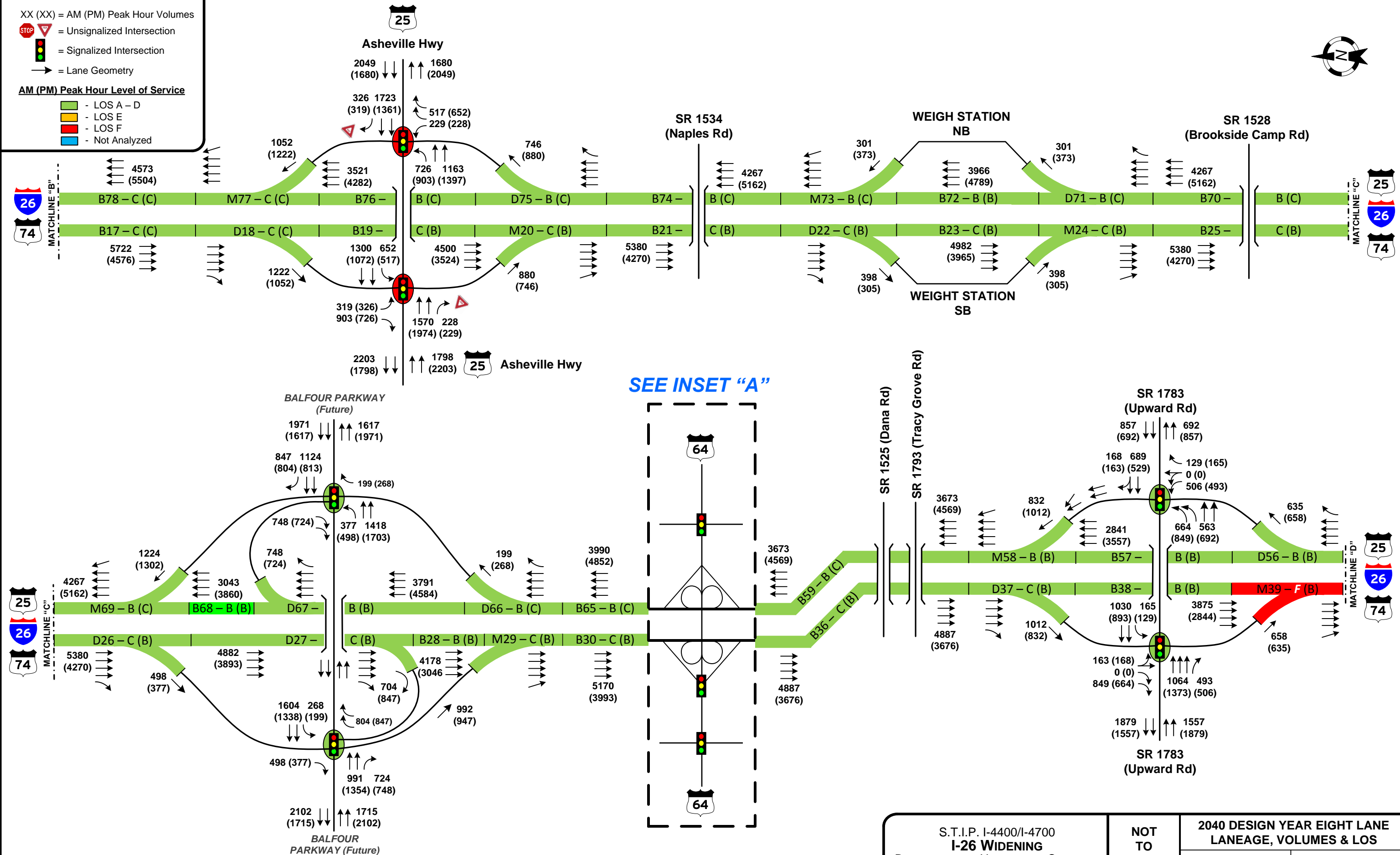

SEE INSET "A"

S.T.I.P. I-4400/I-4700 I-26 WIDENING BUNCOMBE AND HENDERSON COUNTIES	NOT TO SCALE	2040 DESIGN YEAR EIGHT LANE LANEAGE, VOLUMES & LOS	
		DATE: September 2013	FIGURE 9.2

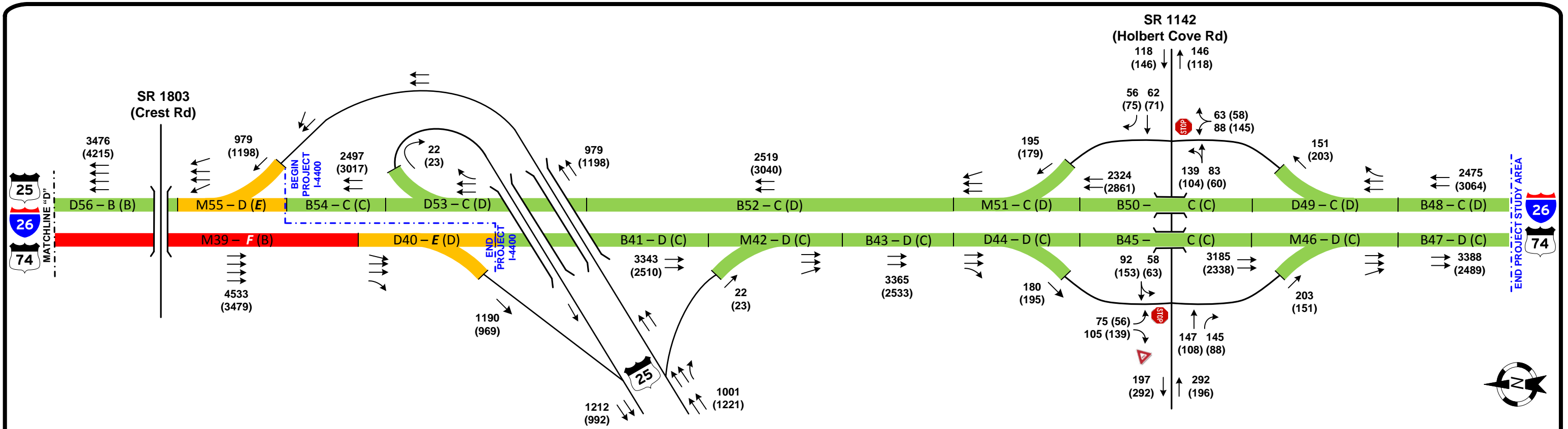

INSET "A"
I-26/US 64
INTERCHANGE

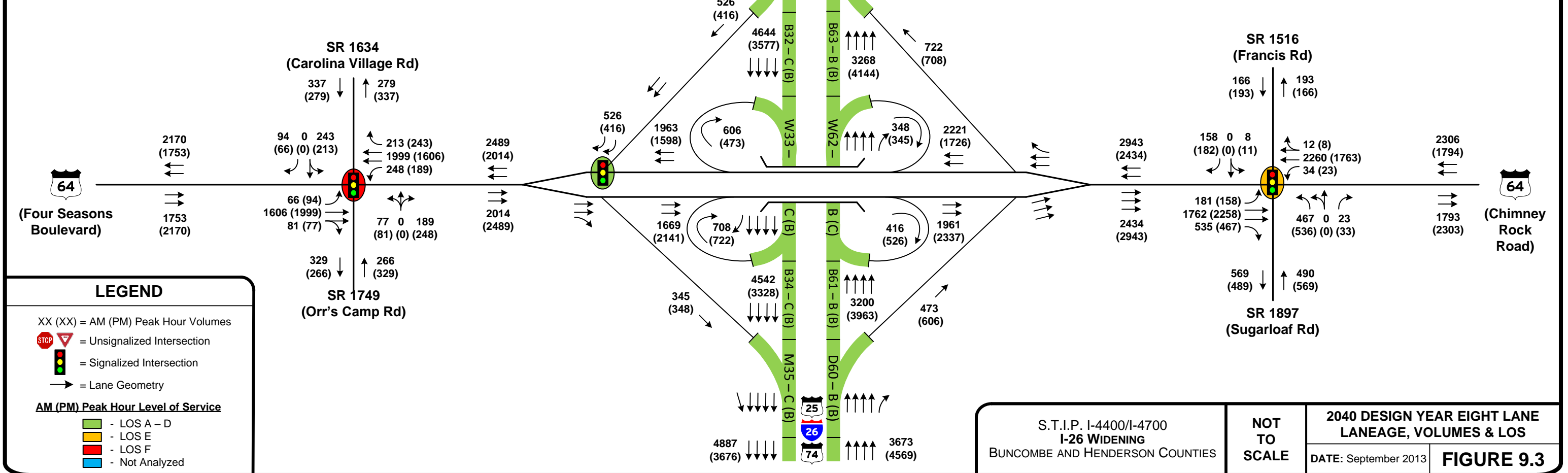

I-26/NC 280 INTERCHANGE DETAIL

NOT TO SCALE

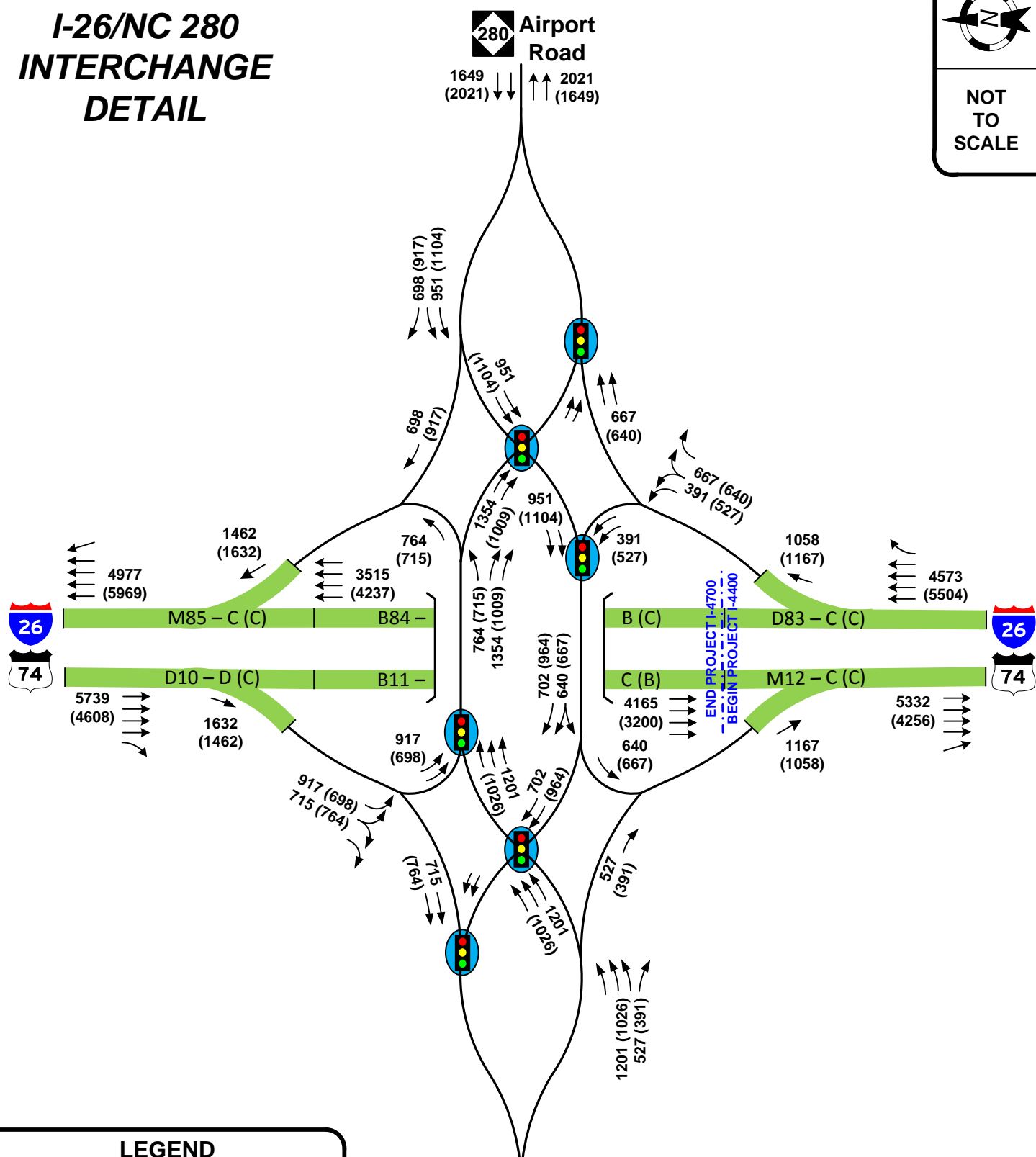

Appendix B – Traffic Forecast Data

Project Level Traffic Forecast Report

TIP PROJECTS

I-4400 / I-4700 / B-5178 / I-5501 Buncombe, Henderson

- I-4400 / I-4700: Widening of I-26 from I-40 in Buncombe Co to US 25 in Henderson Co - WBS# 34232.1.1
- B-5178: Replacement of Buncombe County Bridges 235 and 238 on I-26 over SR 3431-Pond Rd and Hominy Creek - WBS# 42549.1.1
- I-5501: Retrofit exiting I-26 Interchange at NC 280-Airport Rd to a Diverging Diamond Configuration - WBS# 46292.1.1

Delivered: February 14, 2012

Prepared By: Keith Dixon

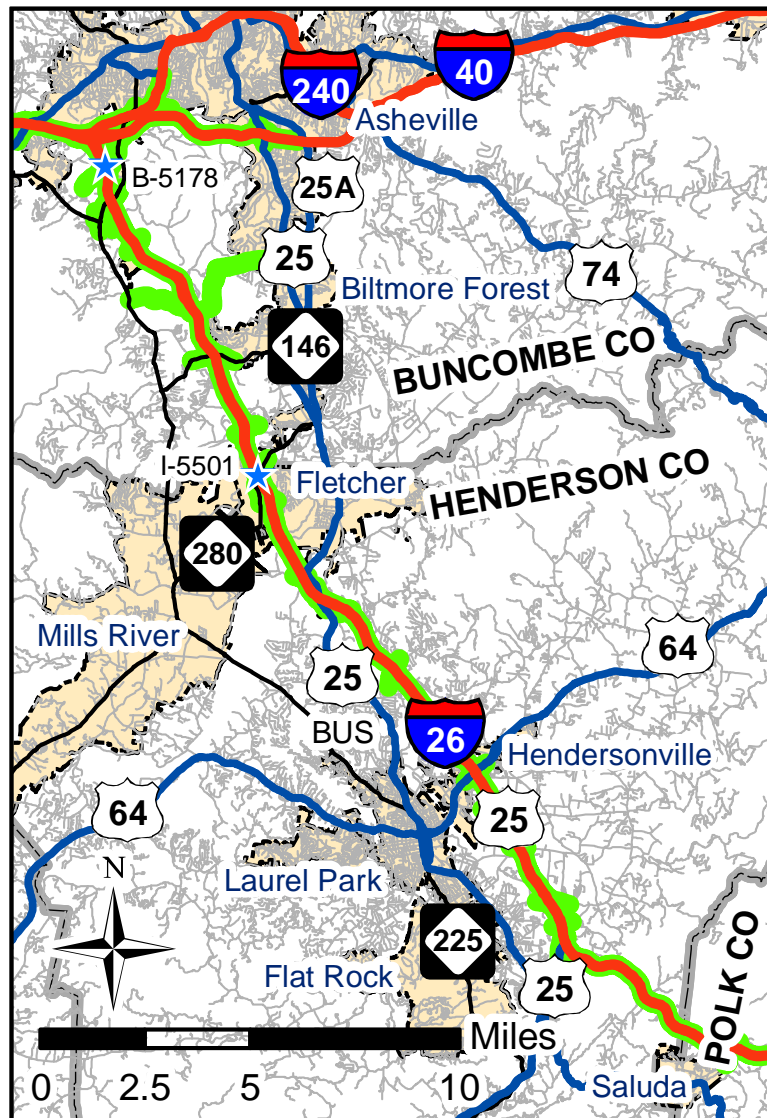

Table of Contents

Traffic Forecast Cover Letter

Traffic Forecast Diagram(s)

Vicinity Map

Traffic Forecast Report

1. *Project Background*

- a. Project Request Information
- b. Route Information
- c. Project Status
- d. Forecast History
- e. Area Information
 - i. Conditions in the Vicinity
 - 1. Asheville
 - 2. Fletcher
 - 3. Hendersonville
 - 4. Polk County
 - ii. Population Growth
 - iii. Traffic Growth
 - iv. Current and Pending Developments
 - 1. Asheville
 - 2. Fletcher
 - 3. Hendersonville
 - 4. Polk County

2. *Sources of Information and Data*

- a. Related Forecasts and Studies
- b. Historic AADT
- c. Field Data Collection (TSG)
- d. Field Investigation
- e. Population Estimates and Growth Projections

3. *2011 No-Build Forecast*

- a. Assumptions
- b. Methodology
- c. Design Factors

4. *General Model Data*

5. *2011 Build Forecasts*

- a. Assumptions Regarding All 2011 Build Scenarios
- b. Assumptions Regarding 2011 Build - 6 Lanes Scenario
- c. Assumptions Regarding 2011 Build - 8 Lanes Scenario
- d. Methodology
- e. Design Factors

6. *2040 No Build Forecast*
 - a. Assumptions
 - b. Fiscal Constraint
 - c. Planned Development Activity
 - d. Methodology
 - e. Design Factors

7. *2040 Build Forecasts*
 - a. Assumptions Regarding All 2040 Build Scenarios
 - b. Assumptions Regarding 2040 Build - 6 Lanes Scenario
 - c. Assumptions Regarding 2040 Build - 8 Lanes Scenario
 - d. Fiscal Constraint
 - e. Methodology
 - f. Design Factors

8. Appendices
 - a. 2011 No Build AADT and Design Factors Estimate
 - b. 2011 Build - 6 Lanes AADT and Design Factors Estimate
 - c. 2011 Build - 8 Lanes AADT and Design Factors Estimate
 - d. 2040 No Build AADT and Design Factors Estimate
 - e. 2040 Build - 6 Lanes AADT and Design Factors Estimate
 - f. 2040 Build - 8 Lanes AADT and Design Factors Estimate
 - g. Information from Local Planners and Others
 - h. Key AADT Trends
 - i. Requested Traffic Counts Information
 - j. Population Estimates and Growth Projections
 - k. French Broad River Calibration Tables
 - l. Field Trip Notes

Traffic Forecast Cover Letter

MEMORANDUM TO: Undrea Major
Project Development and Environmental Analysis Branch (PDEA)

FROM: Keith G. Dixon
Western Traffic Forecasting Group
Transportation Planning Branch

SUBJECT: Traffic Forecast for I-4400 / I-4700 / I-5501/ B-5178
Buncombe and Henderson County
I-26 from I-40 in Buncombe County to US 25 in Henderson County

Please find attached the 2011 / 2040 traffic forecast for I-4400 / I-4700 / I-5501 and B-5178. TIP I-4400 / I-4700 concerns the addition of lanes to I-26 from I-40 in Buncombe County to US 25 in Henderson County. I-5501 concerns the retrofitting of the exiting I-26 Interchange at NC 280-Airport Rd to a Diverging Diamond Configuration. TIP B-5178 concerns the replacement of Bridges 235 and 238 on I-26 over SR 3431 – Pond Rd and Hominy Creek.

A Preliminary Delivery of a portion of the traffic forecast for I-4400 / I-4700/ B-5178 was delivered by Keith Dixon to Joseph Qubain of PDEA, and Tim Goins, PE, of Roadway Design, on October 14, 2011. The remaining intersections, along with a redelivery of the preliminary portions, are included in this delivery, hereafter referred to as the Complete Traffic Forecast. The Complete Traffic Forecast includes all of the intersections for I-4400, I-4700, B-5178 and I-5501.

This is the first known forecast for this portion of I-4400 / I-4700 and for I-5501 and B-5178. This project falls within the French Broad River MPO area (FBRMPO).

The following people were contacted during the development of this traffic forecast:

- Shannon Tuch, Asheville Assistant Planning Director
- Barb Mee, City of Asheville Transportation Planner
- Jon Creighton, Buncombe County Planning Director
- Anthony Star, Henderson County Planning Director
- Cathy Ruth, Polk County Planner
- Susan Anderson, Hendersonville Planning Director
- Eric Rufa, Town of Fletcher Planning Director
- Jamie Laughter, Manager, Town of Mills River
- Bob Moore, The Windsor Aughtry Company, Developer of River Stone
- Anna G. Henderson, PE, Division 13 Traffic Engineer
- Charles Cordray, Division 13 Assistant Resident Engineer
- Paul Black, French Broad River MPO Director
- Linh Nguyen, PE, NCDOT French Broad River MPO Coordinator

The following 6 scenarios are provided:

- 2011 No Build Existing Conditions
- 2011 Build - 6 Lanes
- 2011 Build - 8 Lanes
- 2040 No Build
- 2040 Build - 6 Lanes
- 2040 Build - 8 Lanes

Note: The “Build” and “No Build” designation in the scenarios listed above refers to projects I-4400 / I-4700. TIP projects I-5501 and B-5178 are not estimated to significantly affect travel demand within the forecast area, thus, the Build and No Build AADT for these projects are estimated to be identical, and any differences in forecast scenarios for I-5501 and B-5178 are solely dependent on the build alternative in question for I-4400 / I-4700.

During the preparation of this forecast three TIP projects were under construction:

- **R-0505** – US 25 from NC 225 near Zirconia to I-26. Upgrade to freeway.
 - Completion Date: Open to traffic early October, 2011.
 - Currently 4-lane, divided, freeway.
 - Counts taken on US 25 south of I-26 on November 1st through the 3rd, 2011.
 - R-0505 is assumed to be complete and open to traffic in the 2011 forecast scenarios.
- **U-3601** – Widening of NC 191-Brevard Rd from I-26 to I-40.
 - Completion Date: Open to traffic by October 1, 2011.
 - Currently 4-lane, divided, boulevard.
 - Counts taken on NC 191-Brevard Rd: August 22 - September 8, 2011
 - Counts were taken on NC 191 prior to the completion of U-3601. Therefore, none of the 2011 scenarios assume the completion of U-3601.
- **R-4430** – SR 1783-Upward Rd from US 176 TO SR 1006-Howard Gap Rd. Widen and improve roadway.
 - Estimated Completion Date: August 1st, 2013.
 - R-4430 is NOT assumed to be complete and open to traffic in the 2011 forecast scenarios.

ALL of the projects listed above are assumed to be complete and open to traffic by 2040.

Certain Assumptions were made during the development of this forecast.

Fiscal Constraint:

For projects falling inside an MPO, forecasts are fiscally constrained to the MPO's Long Range Transportation Plan (LRTP). This means that only projects scheduled in the LRTP are considered constructed and open to traffic in the future year.

All projects documented in the 2035 FBRMPO LRTP, adopted 9/23/2010, are included in the 2035 French Broad River Regional Transportation Demand Model, adopted 3/25/2010, (FBRTDM) runs used to produce this forecast and are considered complete and open to traffic by 2040. These projects include:

- U-2801: US 25A from US 25 to I-40. Widen to multi-lanes.
- U-3403A & B: Widen NC 191 from the Blue Ridge Parkway to NC 280. Widen to multi-lanes.
- I-2513: I-26 Connector. I-26 to US 19-23-70. Multi-lane freeway, part on new location.
- R-2813A: Widening of NC 146 from SR 3501 to NC 191. Widen to multi-lanes.
- R-4430: SR 1783-Upward Rd. Widen and improve roadway from US 176 to SR 1006-Howard Gap Rd. Under construction.
- Balfour Parkway: Construct New 4-lane Expressway from NC 191 to US 64 north of Hendersonville

None of the projects listed above are assumed to be open to traffic in any of the 2011 traffic forecast scenarios.

I-4400 and I-4700 are both scheduled for construction in 2020 in the 2012-2020 STIP.

I-5501 is scheduled for construction in 2013 and B-5178 is scheduled for construction in 2012, in the 2012-2020 STIP.

Development Activity:

Biltmore Estate's West Gate: Biltmore Estates is planning to open an additional entrance to be located southeast of NC 191-Brevard Rd just east of I-26 that will be known as the Biltmore Estate's West Gate. At the request of the original forecast requestor, PDEA Engineer, Joseph Qubain, the opening of the Biltmore Estate's West Gate is assumed in all of the 2011 and 2040 Build Scenarios included with this traffic forecast. The inclusion of the Biltmore Estate's West Gate in the 2011 Build Scenarios will allow for the interpolation of forecast volumes between matching 2011 and 2040 build alternatives.

A *Traffic Impact Analysis for the Proposed Biltmore Estate's West Gate* was prepared by Ramey Kemp & Associates, Inc. in November of 2010 (Biltmore TIA). At the request of Joseph Qubain and NCDOT Congestion Management Western Regional Engineer, James Dunlop, PE, the assumptions used in this traffic forecast regarding the redistribution of traffic due to the inclusion of the Biltmore Estate's West Gate are based upon the Biltmore TIA.

Based upon input from local planners there are several other developments that have been approved along the project corridor between Asheville and Flat Rock that are estimated to affect traffic within the forecast area in the horizon year scenarios:

- *Dollar General Market & other retail:* Located on US 19 about 2 miles south of I-40.
- *Electrolux Expansion:* Located on NC 280 south of I-26 near the airport.
- *Enka Center:* Located at the site of the old Enka Rayon Plant on NC 112 near US 19.
- *Ingles Market Rebuild & Expansion:* Ingles shopping center located on US 19 north of I-40 and Ingles store located on NC 191 across from the Biltmore Square Mall.
- *The Aventine Apartments:* Located on NC 146-Long Shoals Rd west of I-26.
- *River Stone:* Located on SR 1345-Butler Bridge Rd about 0.5 miles from US 25 in Henderson Co.
- *Ballentyne Apartments:* Located near Howard Gap Rd and US 64 East in Henderson Co.

Based upon a review of the 2035 FBRTDM Socioeconomic (SE) data, these developments fall within the scope of the SE data growth currently estimated within the forecast area and are assumed to be complete in the 2040 forecast scenarios.

Forecast Methodology:

2011 traffic volumes and traffic factor estimates are based upon current counts and historic AADT trends projected to 2011. 2040 traffic volumes were estimated using growth rates derived from the FBRTDM, adopted March 25, 2010, along with historic growth rates. The redistribution of traffic due to the inclusion of the Biltmore Estate's West Gate was estimated in accordance with the Biltmore TIA produced in November of 2010.

The corresponding areas between this Complete Forecast and the Preliminary Forecast are identical with the following two exceptions:

- 1) The AADT estimates on the Ingles Market Driveway west of NC 191 were increased based upon the approved developments listed above.
- 2) The traffic factors in the Build scenarios on NC 191 near the Proposed Biltmore Estate's West Gate were changed in order to improve the balancing of the traffic factors at this intersection.

If it is determined that any of these assumptions have become inconsistent with the project and surrounding area activity, please request updated projections at this location.

To estimate AADT for intermediate years, straight-line interpolation may be used between matching build alternatives. AADT volumes may be extrapolated for up to 2 years following 2040.

For future reference, this forecast will be saved in Project Store under I4400, I5501 and B5178 in the LongRangePlanning\Traffic Forecasts folders.

If we can be of any further assistance on this project please do not hesitate to contact me at 919-707-0984, email: kdixon1@ncdot.gov or Michael Orr, AICP, at 919-707-0982, email: mlorr@ncdot.gov.

CC (with Attachments):

Jay Bennett, PE, Roadway Design
Pam Cook, PE, Transportation Planning Branch
Deborah Hutchings, PE, Transportation Planning Branch
James Dunlop, PE, Congestion Management
Don Chen, PE, Pavement Management
Vincent J. Rhea, PE, PDEA
Clayton Walston, Roadway Design
Deborah Barbour, PE, Preconstruction
File Copy: I-4400 / I-4700 Buncombe Henderson County
File Copy: I-5501 Buncombe Henderson County
File Copy: B-5178 Buncombe County

Traffic Forecast Diagrams

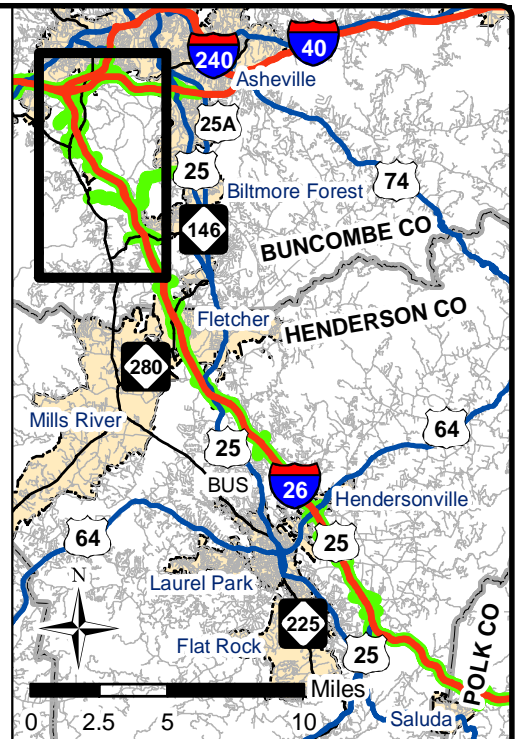
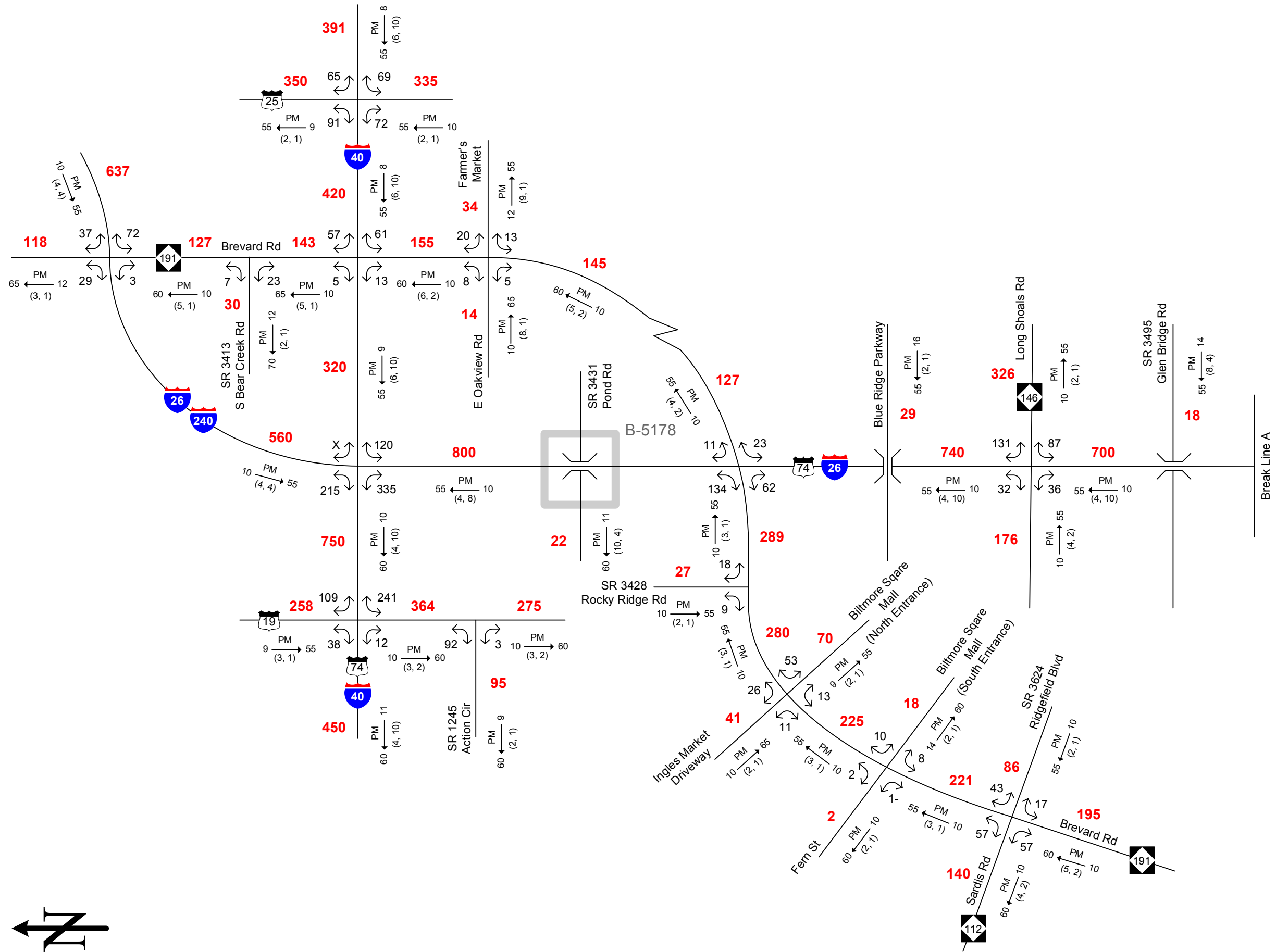

2011
ANNUAL AVERAGE
DAILY TRAFFIC
No Build
Existing Conditions
SHEET 1 - 1

LEGEND

- ### No. of Vehicles Per Day (VPD) in 100s
- 1- Less than 50 VPD
- X Movement Prohibited
- Roadway
- K Design Hour Factor (%)
- PM PM Peak Period
- D Peak Hour Directional Split
- Indicates Direction of D
- (d,t) Duals, TT-STs (%)

TIP: I-4400 / I-4700 WBS: 34232.1.1

COUNTY: Buncombe DIVISION: 13

DATE: 02-14-2012

PREPARED BY: Keith Dixon

LOCATION: I-26 from I-40 in Buncombe Co. to US 25 in Henderson Co.

PROJECT: Widen I-26



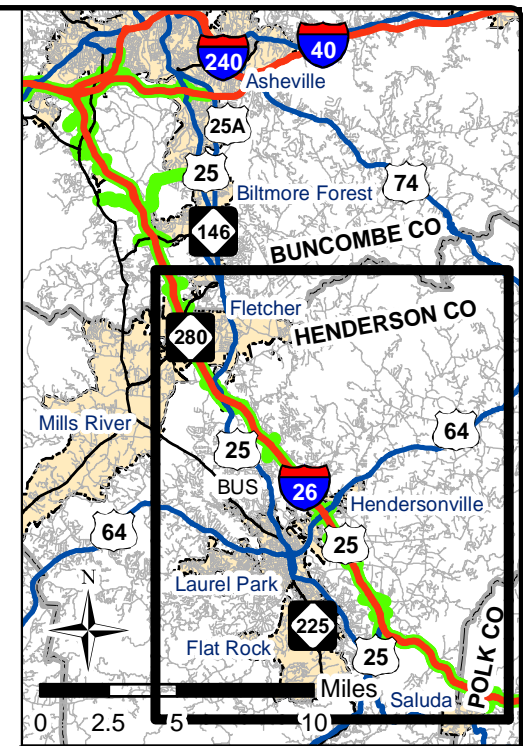
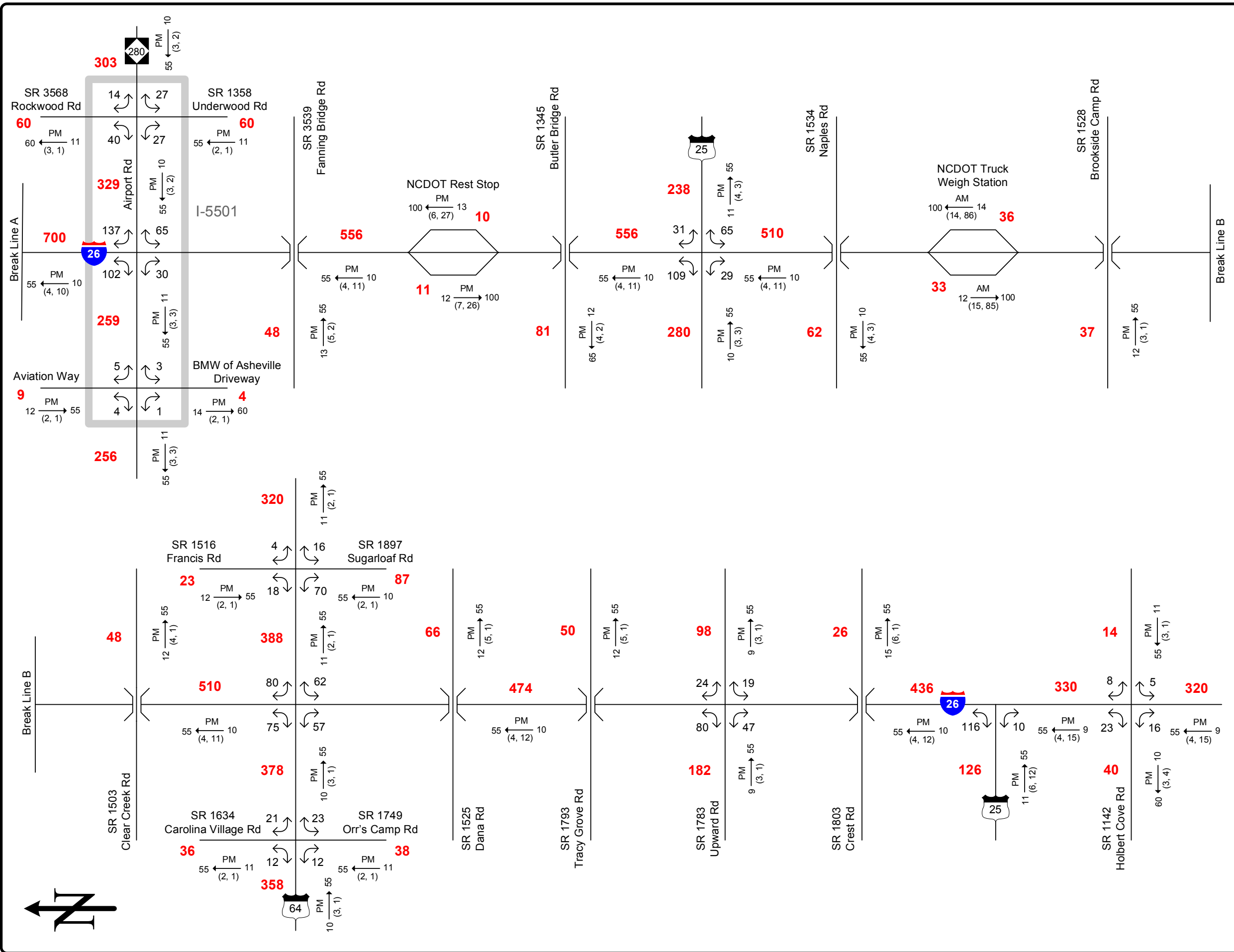

2011

ANNUAL AVERAGE
DAILY TRAFFIC

No Build Existing Conditions

SHEET 1 - 2

- ### LEGEND
- $\overleftarrow{K} \xrightarrow{D}$
K (d,t) → D
 - ### No. of Vehicles Per Day (VPD) in 100s
 - 1- Less than 50 VPD
 - X Movement Prohibited
 - Roadway
 - K Design Hour Factor (%)
 - PM PM Peak Period
 - D Peak Hour Directional Split
 - Indicates Direction of D
 - (d,t) Duals, TT-STs (%)

TIP: I-4400 / I-4700	WBS: 34232.1.1
COUNTY: Buncombe	DIVISION: 13
DATE: 02-14-2012	
PREPARED BY: Keith Dixon	
LOCATION: I-26 from I-40 in Buncombe Co. to US 25 in Henderson Co.	
PROJECT: Widen I-26	

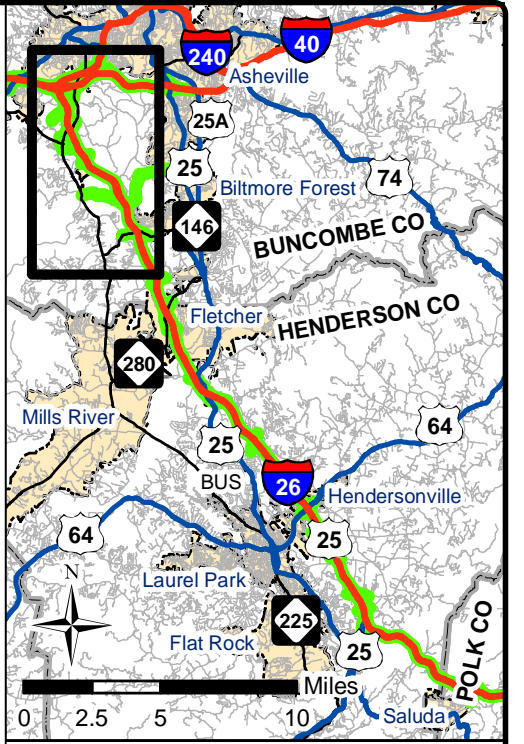
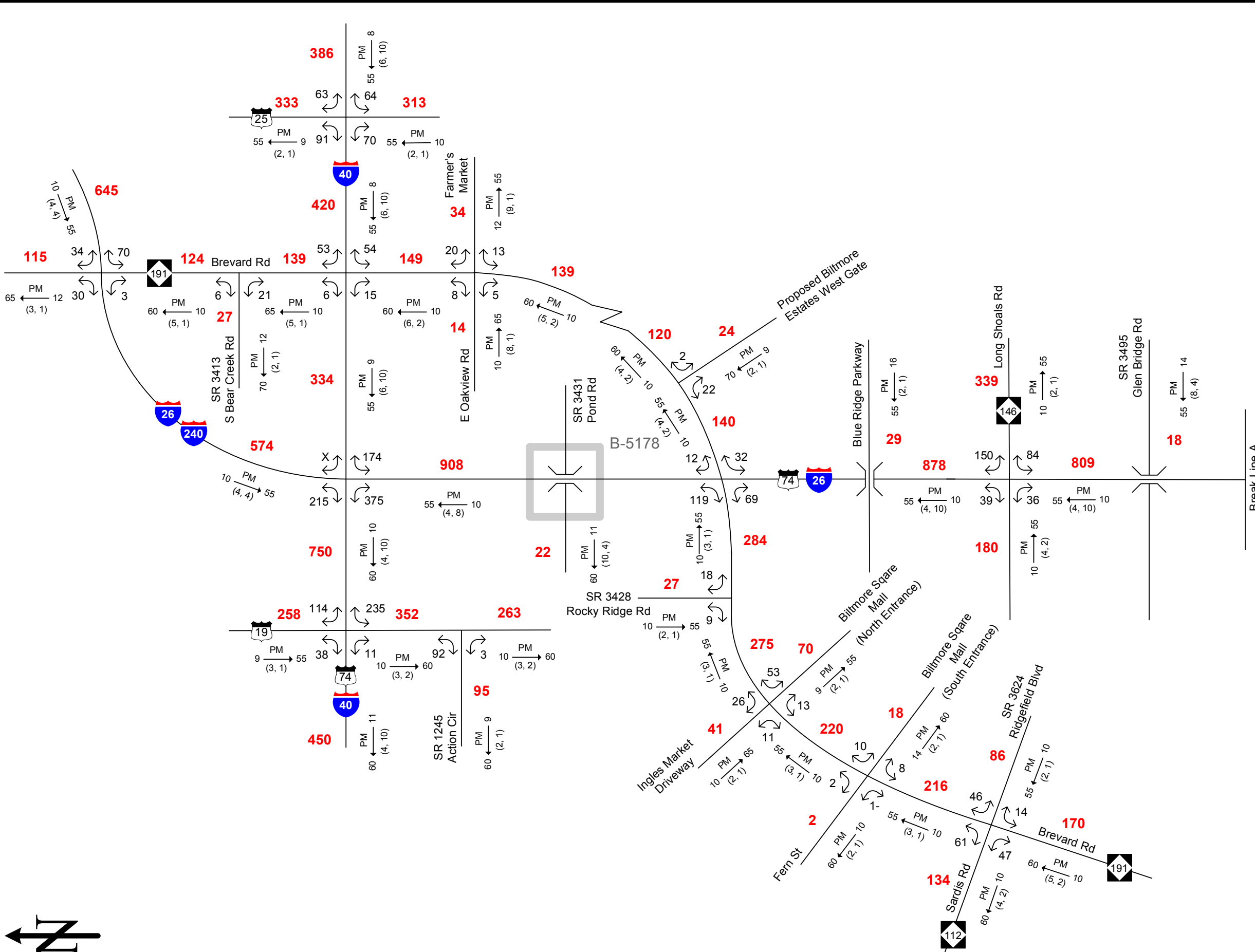

2011

ANNUAL AVERAGE DAILY TRAFFIC

Build - 6 Lanes

SHEET 2 - 1

LEGEND

- K ^{PM} / (d, t) → D
 #### No. of Vehicles Per Day (VPD) in 100s
 1- Less than 50 VPD
 X Movement Prohibited
 ----- Roadway
 K Design Hour Factor (%)
 PM PM Peak Period
 D Peak Hour Directional Split
 → Indicates Direction of D
 (d,t) Duals, TT-STs (%)

TIP: I-4400 / I-4700 **WBS:** 34232.1.1

COUNTY: Buncombe **DIVISION:** 13

DATE: 02-14-2012

PREPARED BY: Keith Dixon

LOCATION: I-26 from I-40 in Buncombe Co. to US 25 in Henderson Co.

PROJECT: Widen I-26



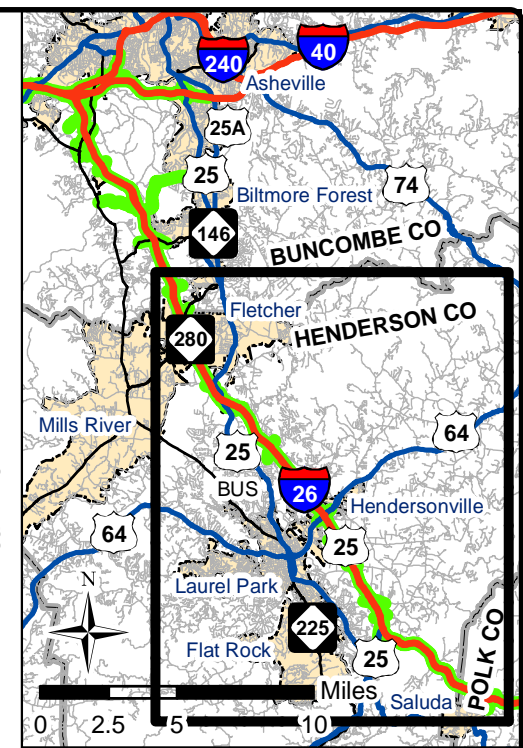
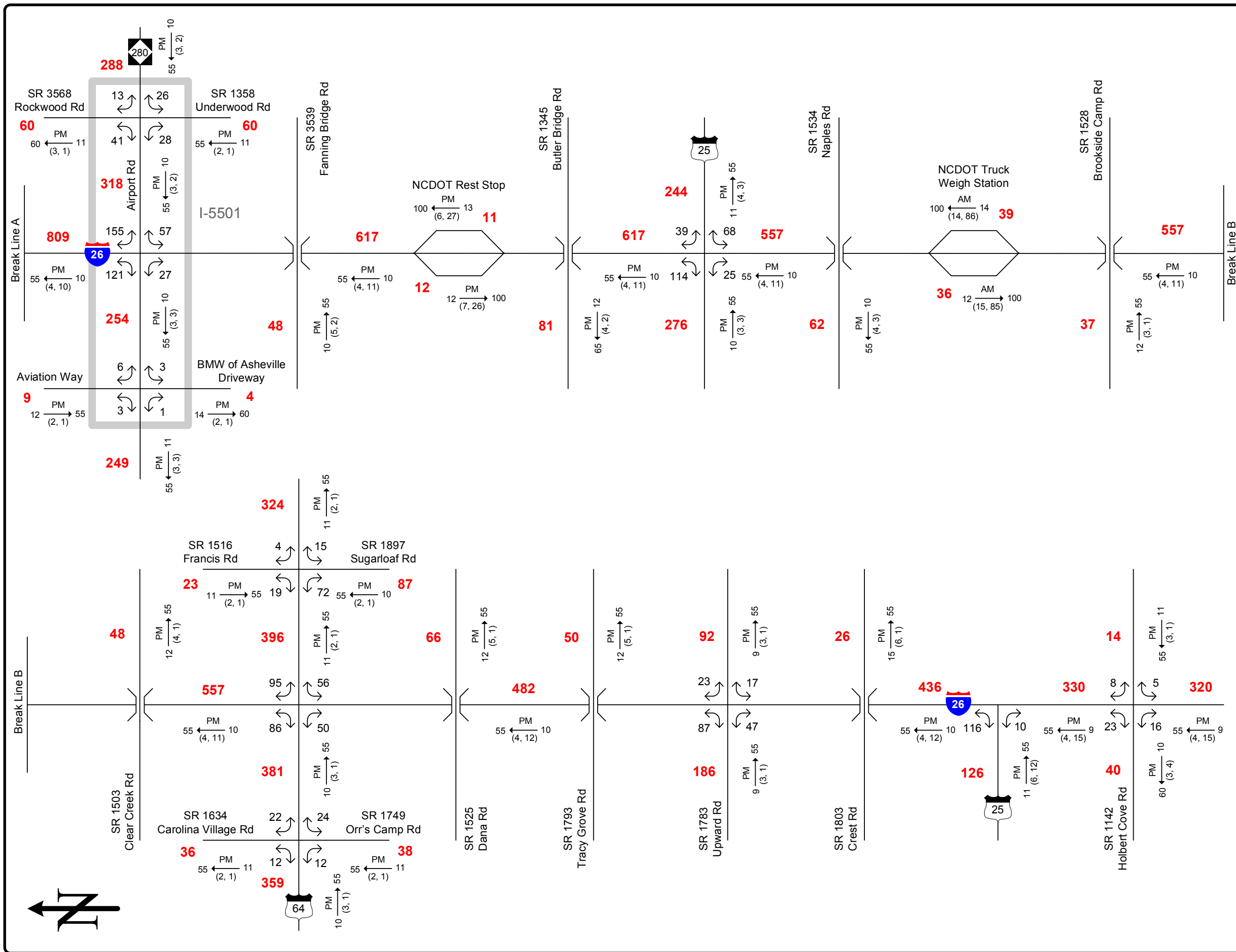

2011

ANNUAL AVERAGE
DAILY TRAFFIC

Build – 6 Lanes

SHEET 2 - 2

LEGEND

- $\frac{K}{(d,t)} \xrightarrow{PM} D$
- ### No. of Vehicles Per Day (VPD) in 100s
- 1- Less than 50 VPD
- X Movement Prohibited
- Roadway
- K Design Hour Factor (%)
- PM PM Peak Period
- D Peak Hour Directional Split
- Indicates Direction of D
- (d,t) Duals, TT-STs (%)

TIP: I-4400 / I-4700 WBS: 34232.1.1

COUNTY: Buncombe DIVISION: 13

DATE: 02-14-2012

PREPARED BY: Keith Dixon

LOCATION: I-26 from I-40 in Buncombe Co. to US 25 in Henderson Co.

PROJECT: Widen I-26

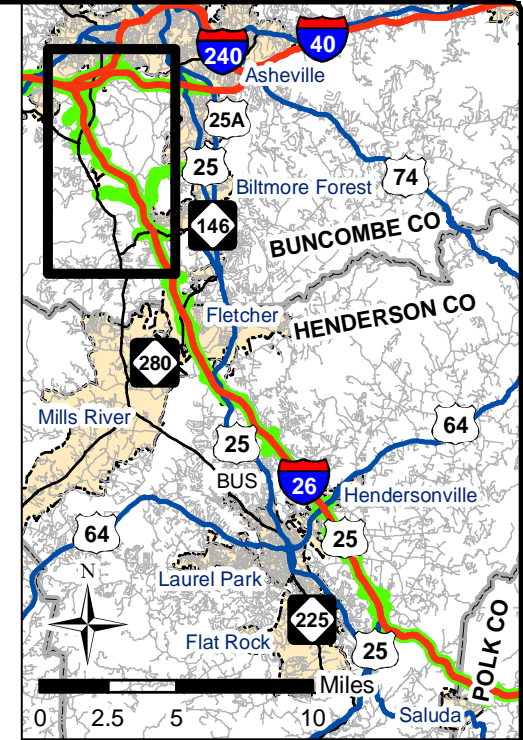
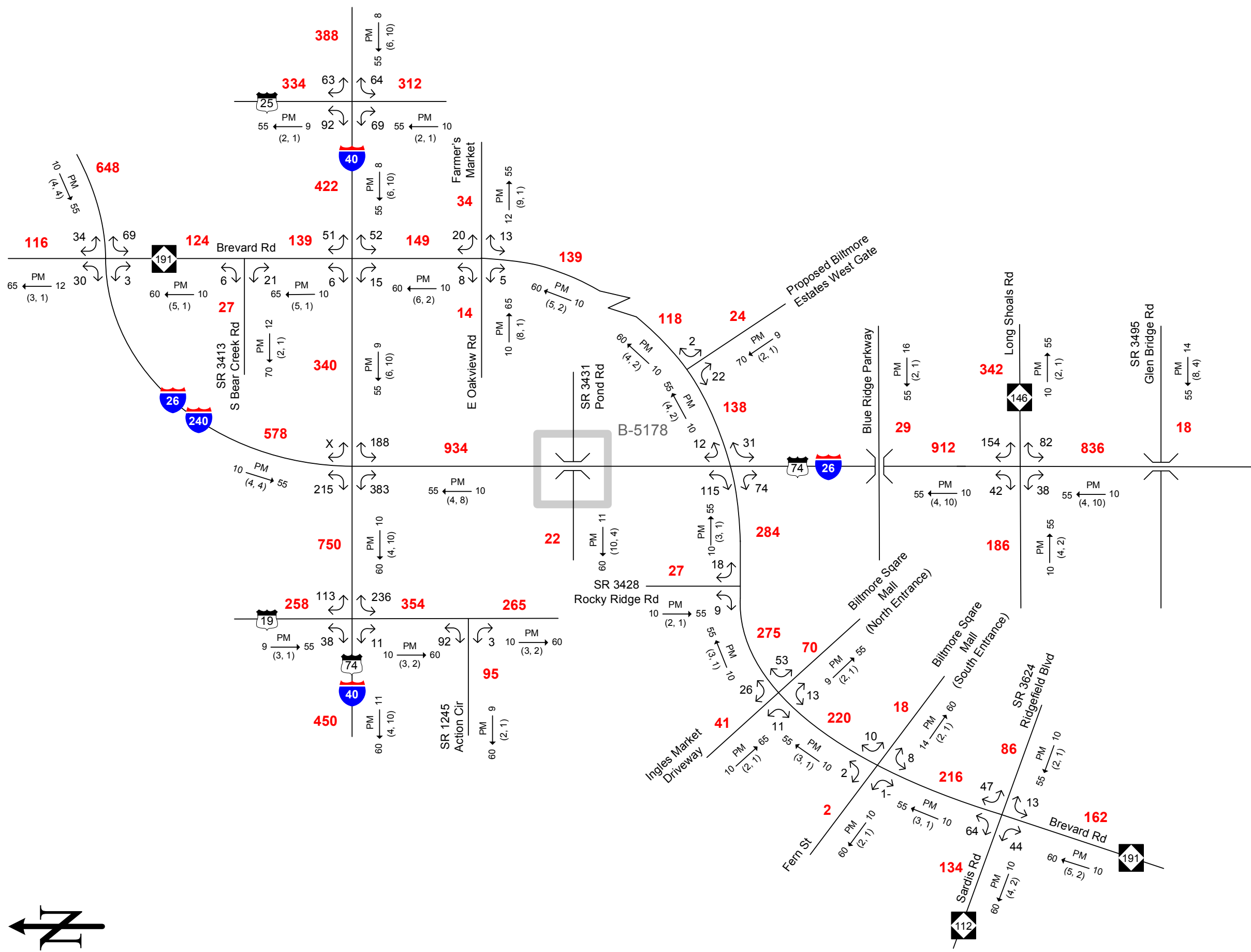

2011

ANNUAL AVERAGE
DAILY TRAFFIC

Build - 8 Lanes

SHEET 3 - 1

LEGEND

K $\frac{PM}{(d, t)}$ \rightarrow D

- ### No. of Vehicles Per Day (VPD) in 100s
- 1- Less than 50 VPD
- X Movement Prohibited
- Roadway
- K Design Hour Factor (%)
- PM PM Peak Period
- D Peak Hour Directional Split
- \rightarrow Indicates Direction of D
- (d,t) Duals, TT-STs (%)

TIP: I-4400 / I-4700 WBS: 34232.1.1

COUNTY: Buncombe DIVISION: 13

DATE: 02-14-2012

PREPARED BY: Keith Dixon

LOCATION: I-26 from I-40 in Buncombe Co. to US 25 in Henderson Co.

PROJECT: Widen I-26



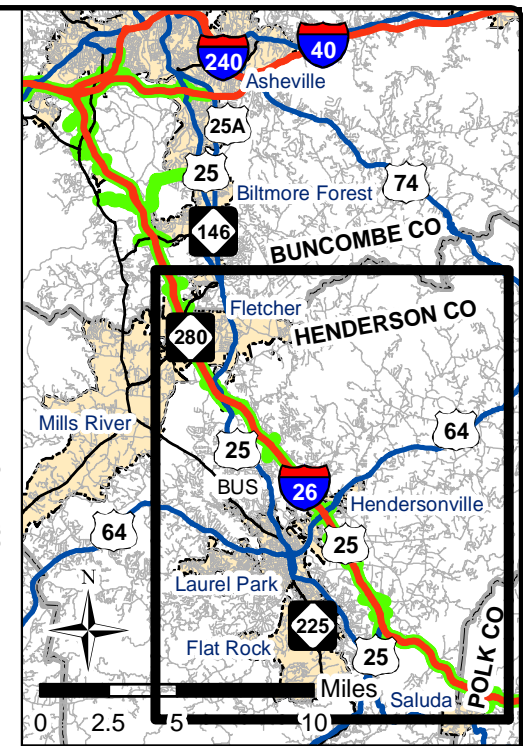
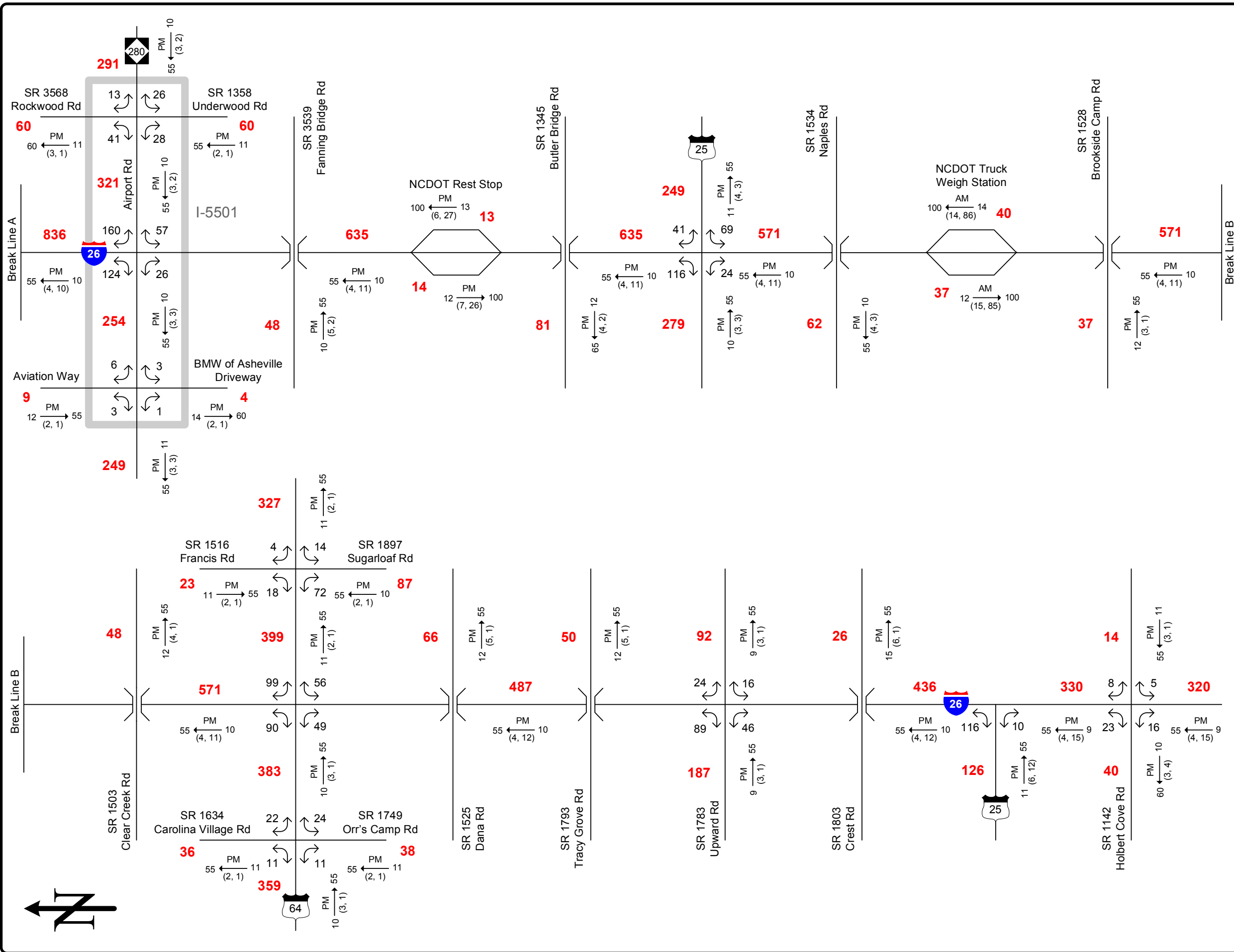

2011

ANNUAL AVERAGE
DAILY TRAFFIC

Build – 8 Lanes

SHEET 3 - 2

LEGEND

- $\overleftarrow{K} \xrightarrow{D}$
K (d,t) → D
- ### No. of Vehicles Per Day (VPD) in 100s
- 1- Less than 50 VPD
- X Movement Prohibited
- Roadway
- K Design Hour Factor (%)
- PM PM Peak Period
- D Peak Hour Directional Split
- Indicates Direction of D
- (d,t) Duals, TT-STs (%)

TIP: I-4400 / I-4700	WBS: 34232.1.1
COUNTY: Buncombe	DIVISION: 13
DATE: 02-14-2012	
PREPARED BY: Keith Dixon	
LOCATION: I-26 from I-40 in Buncombe Co. to US 25 in Henderson Co.	
PROJECT: Widen I-26	

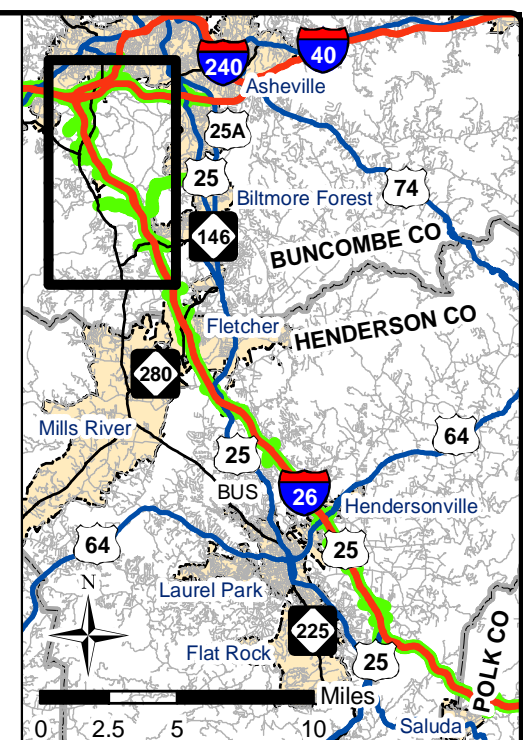
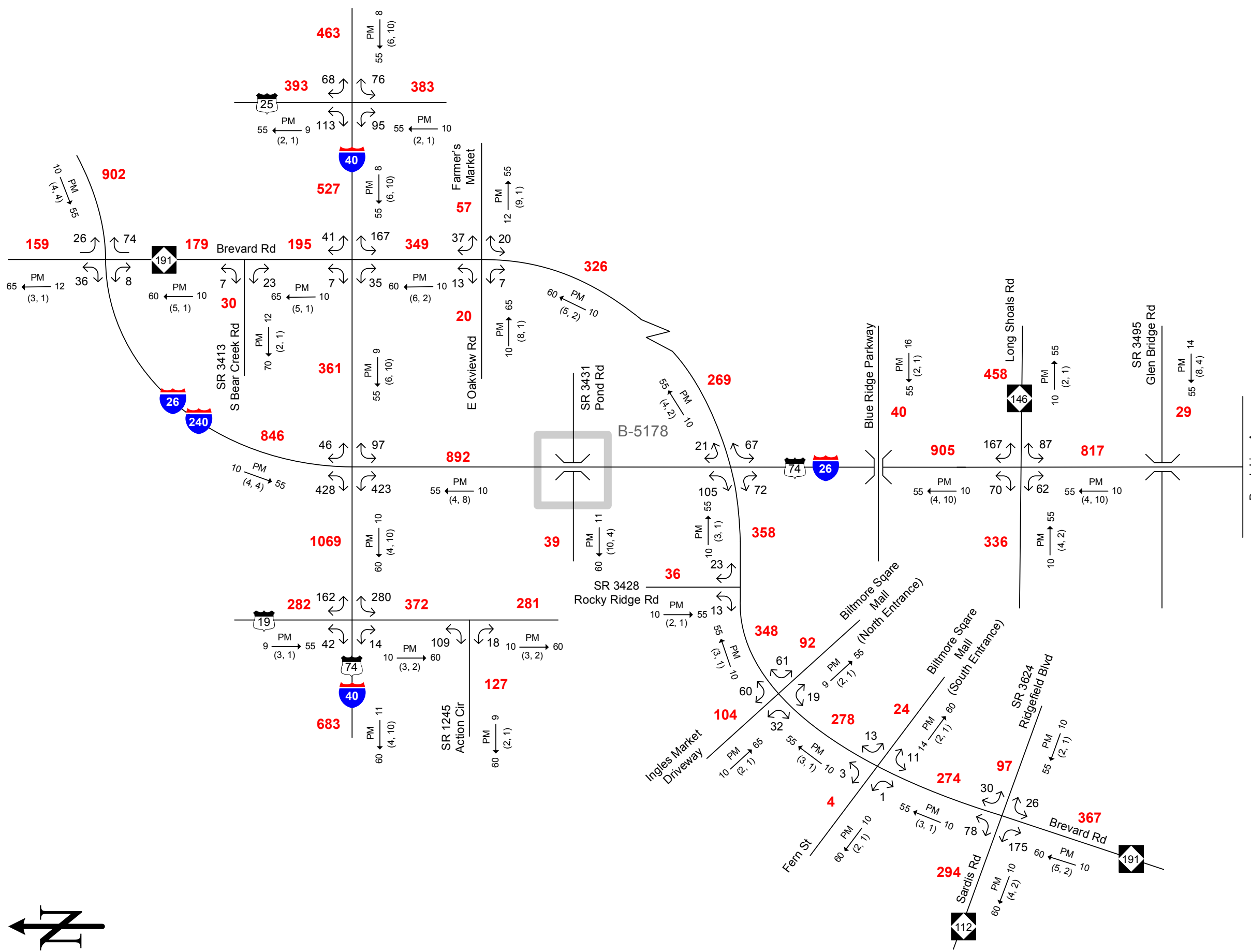

2040
ANNUAL AVERAGE
DAILY TRAFFIC

No Build
SHEET 4 - 1

LEGEND

- ### No. of Vehicles Per Day (VPD) in 100s
- 1- Less than 50 VPD
- X Movement Prohibited
- Roadway
- K Design Hour Factor (%)
- PM PM Peak Period
- D Peak Hour Directional Split
- Indicates Direction of D
- (d,t) Duals, TT-STs (%)

TIP: I-4400 / I-4700 WBS: 34232.1.1

COUNTY: Buncombe DIVISION: 13

DATE: 02-14-2012

PREPARED BY: Keith Dixon

LOCATION: I-26 from I-40 in Buncombe Co. to US 25 in Henderson Co.

PROJECT: Widen I-26



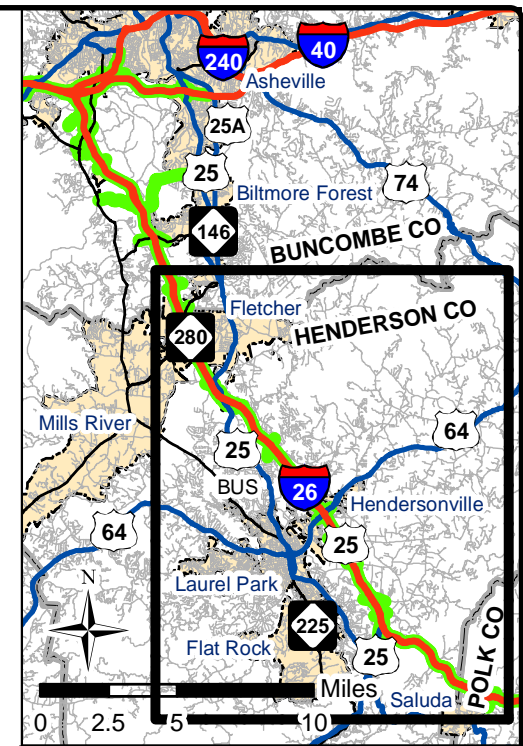
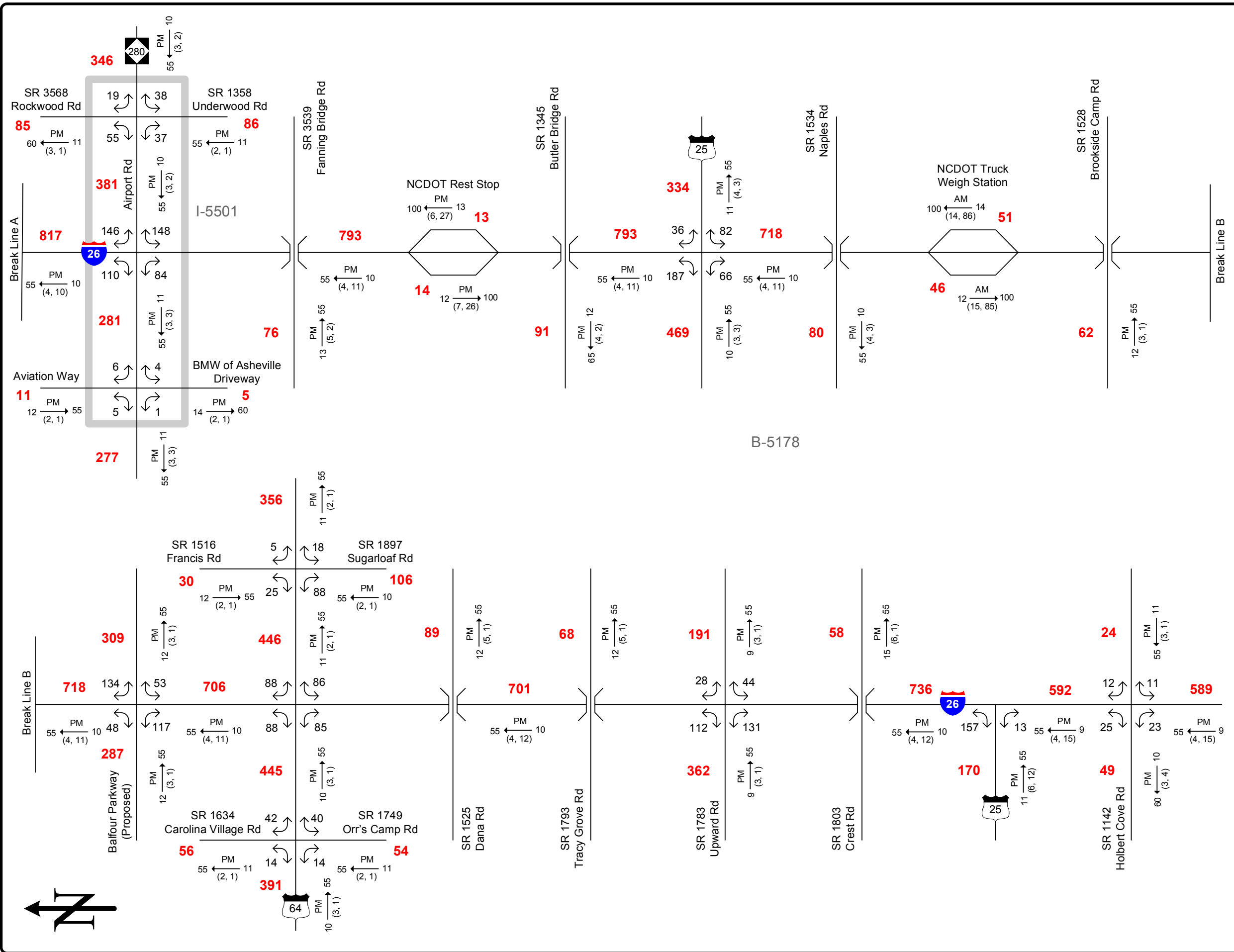

2040
ANNUAL AVERAGE
DAILY TRAFFIC

No Build

SHEET 4 - 2

LEGEND

- $\frac{K}{(d,t)} \xrightarrow{PM} D$
- ### No. of Vehicles Per Day (VPD) in 100s
- 1- Less than 50 VPD
- X Movement Prohibited
- Roadway
- K Design Hour Factor (%)
- PM PM Peak Period
- D Peak Hour Directional Split
- Indicates Direction of D
- (d,t) Duals, TT-STs (%)

TIP: I-4400 / I-4700 WBS: 34232.1.1

COUNTY: Buncombe DIVISION: 13

DATE: 02-14-2012

PREPARED BY: Keith Dixon

LOCATION: I-26 from I-40 in Buncombe Co. to US 25 in Henderson Co.

PROJECT: Widen I-26

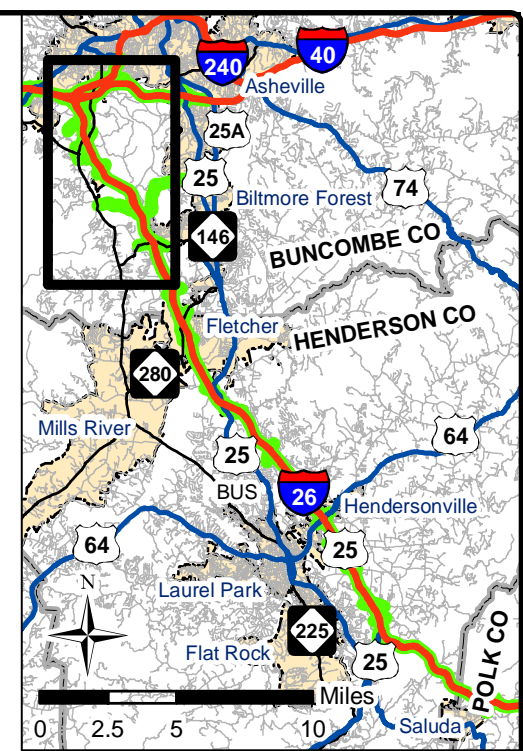
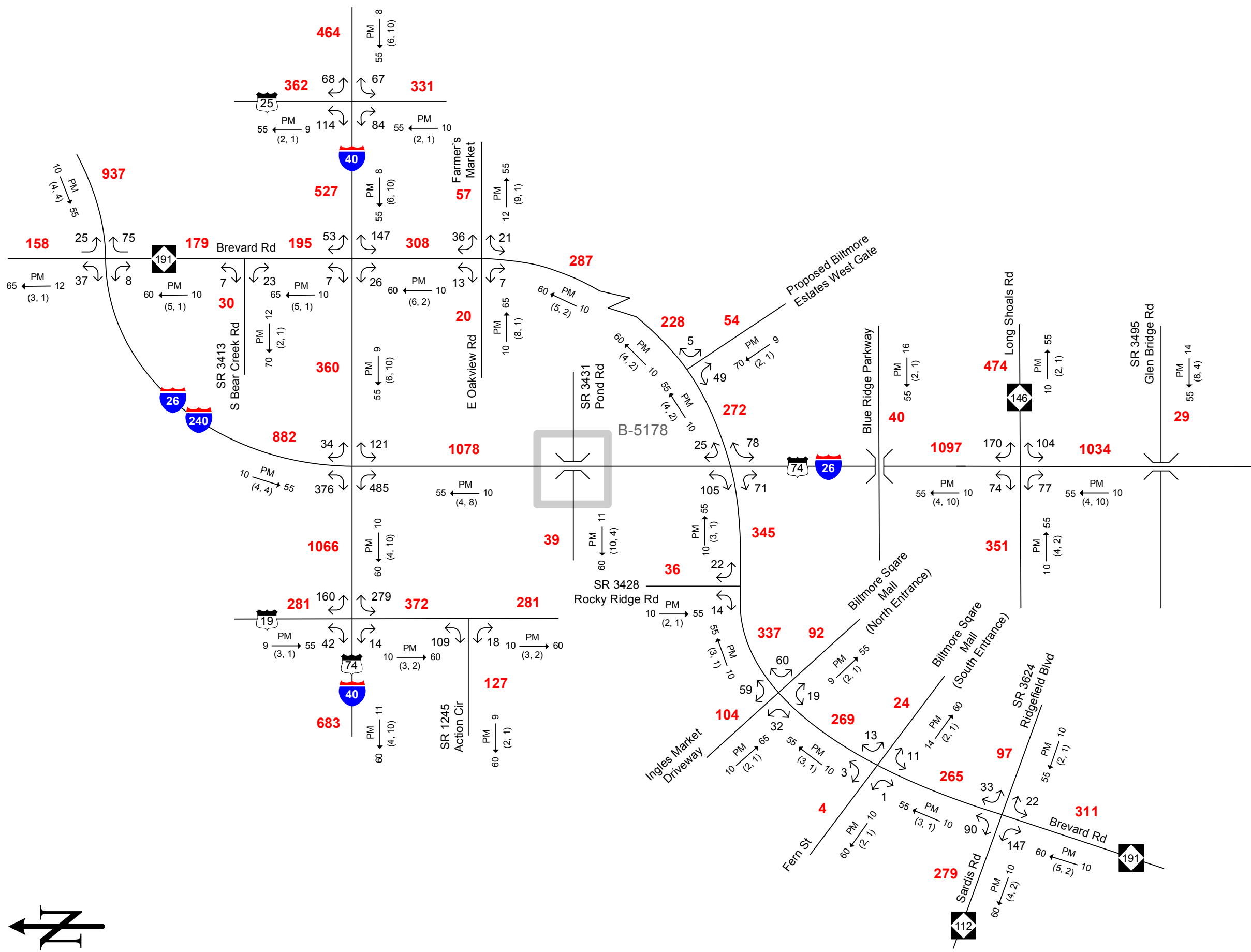

2040

ANNUAL AVERAGE
DAILY TRAFFIC

Build - 6 Lanes

SHEET 5 - 1

LEGEND

- $K \xrightarrow{PM} D$
(d, t)
- ### No. of Vehicles Per Day (VPD) in 100s
- 1- Less than 50 VPD
- X Movement Prohibited
- Roadway
- K Design Hour Factor (%)
- PM PM Peak Period
- D Peak Hour Directional Split
- Indicates Direction of D
- (d,t) Duals, TT-STs (%)

TIP: I-4400 / I-4700 WBS: 34232.1.1

COUNTY: Buncombe DIVISION: 13

DATE: 02-14-2012

PREPARED BY: Keith Dixon

LOCATION: I-26 from I-40 in Buncombe Co. to US 25 in Henderson Co.

PROJECT: Widen I-26



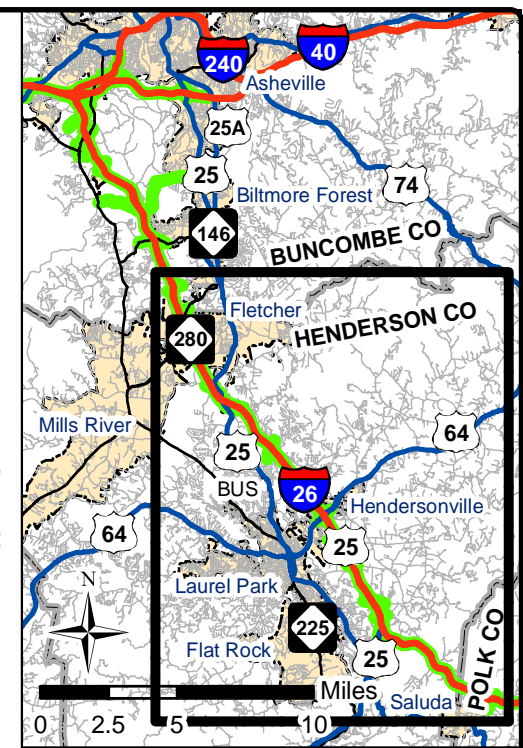
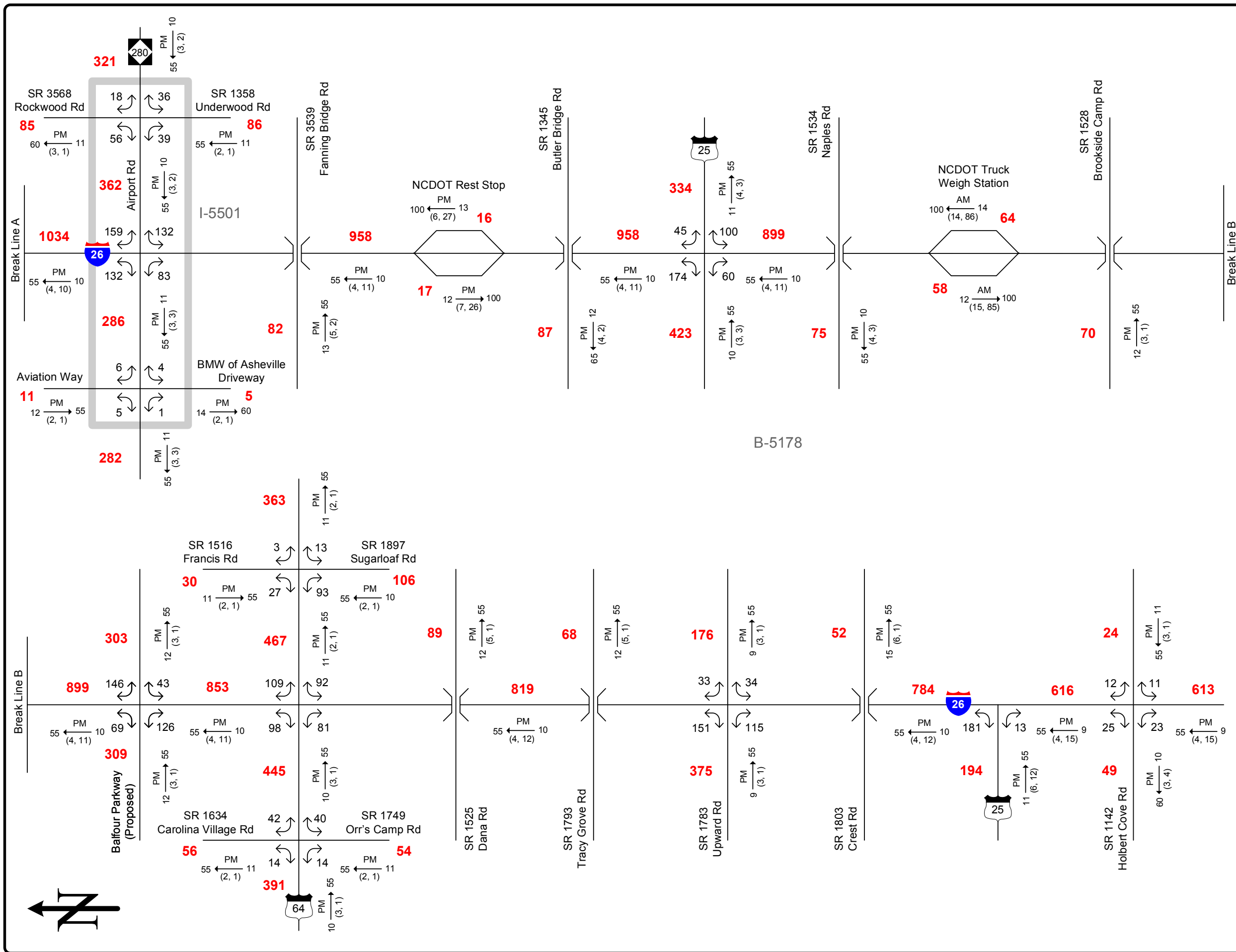

2040
ANNUAL AVERAGE
DAILY TRAFFIC

Build – 6 Lanes

SHEET 5 - 2

LEGEND

- $\frac{K}{(d,t)} \xrightarrow{PM} D$
- ### No. of Vehicles Per Day (VPD) in 100s
- 1- Less than 50 VPD
- X Movement Prohibited
- Roadway
- K Design Hour Factor (%)
- PM PM Peak Period
- D Peak Hour Directional Split
- Indicates Direction of D
- (d,t) Duals, TT-STs (%)

TIP: I-4400 / I-4700 WBS: 34232.1.1

COUNTY: Buncombe DIVISION: 13

DATE: 02-14-2012

PREPARED BY: Keith Dixon

LOCATION: I-26 from I-40 in Buncombe Co. to US 25 in Henderson Co.

PROJECT: Widen I-26

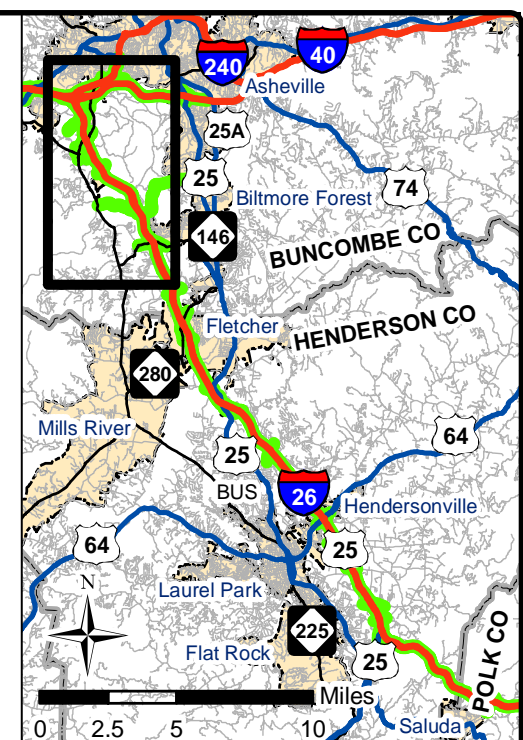
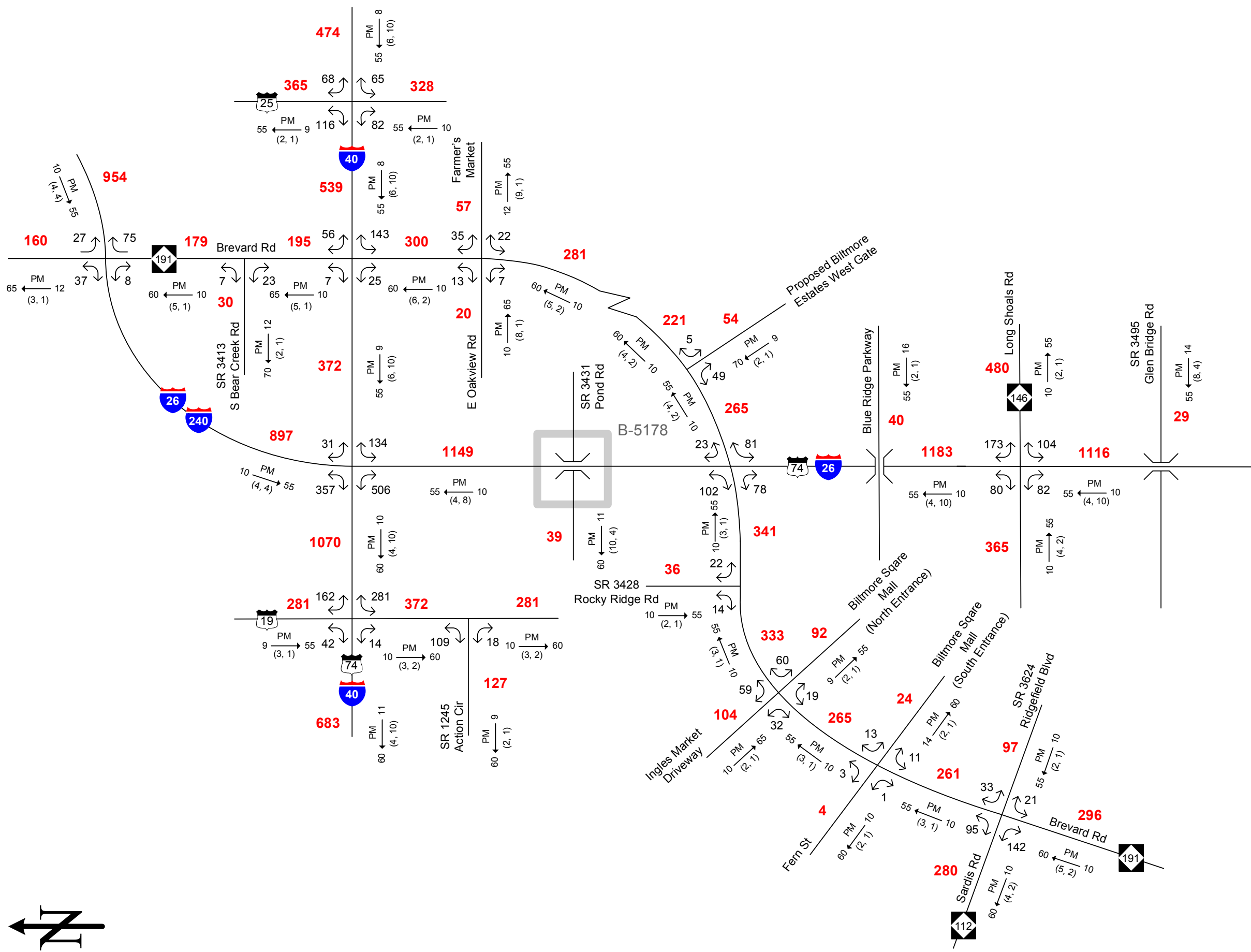

2040
 ANNUAL AVERAGE
 DAILY TRAFFIC

Build - 8 Lanes

SHEET 6 - 1

LEGEND

- ### No. of Vehicles Per Day (VPD) in 100s
- 1- Less than 50 VPD
- X Movement Prohibited
- Roadway
- K Design Hour Factor (%)
- PM PM Peak Period
- D Peak Hour Directional Split
- Indicates Direction of D
- (d,t) Duals, TT-STs (%)

TIP: I-4400 / I-4700	WBS: 34232.1.1
COUNTY: Buncombe	DIVISION: 13
DATE: 02-14-2012	
PREPARED BY: Keith Dixon	
LOCATION: I-26 from I-40 in Buncombe Co. to US 25 in Henderson Co.	
PROJECT: Widen I-26	



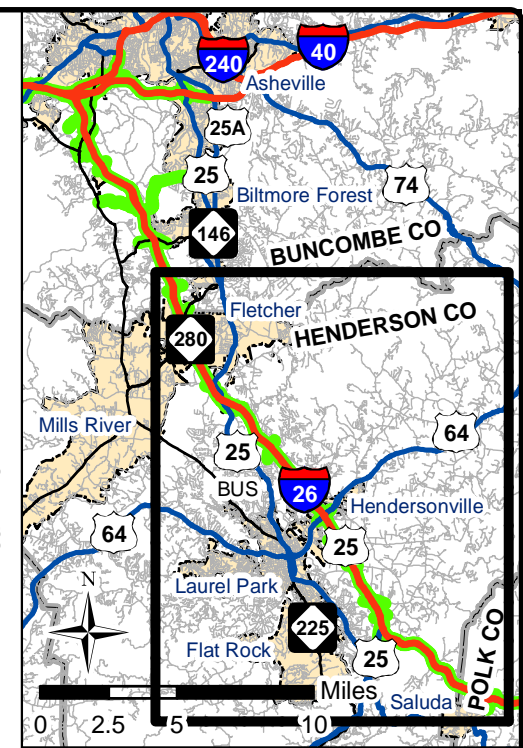
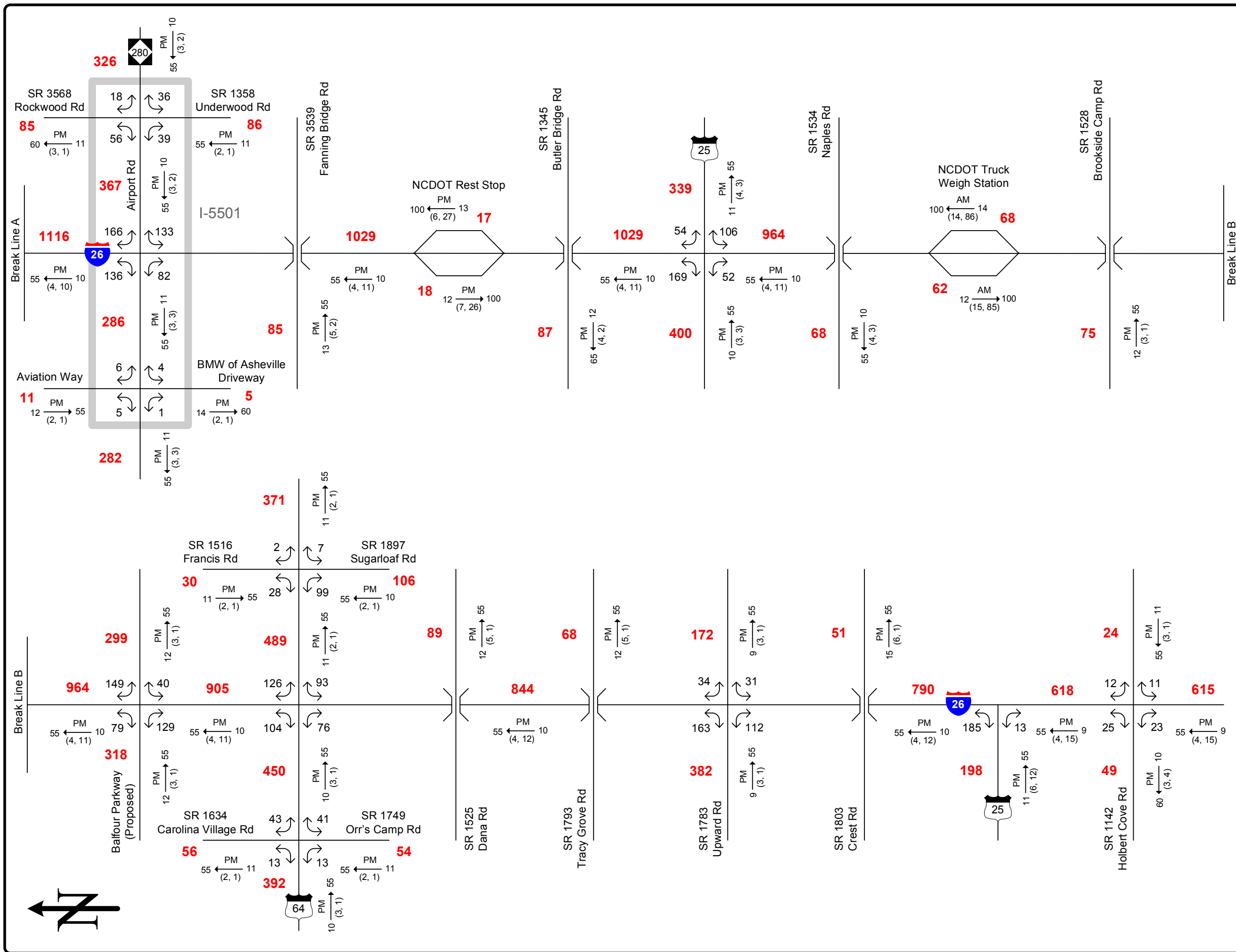

2040
ANNUAL AVERAGE
DAILY TRAFFIC

Build – 8 Lanes

SHEET 6 – 2

LEGEND

- $\frac{K}{(d,t)} \xrightarrow{PM} D$
- ### No. of Vehicles Per Day (VPD) in 100s
- 1- Less than 50 VPD
- X Movement Prohibited
- Roadway
- K Design Hour Factor (%)
- PM PM Peak Period
- D Peak Hour Directional Split
- Indicates Direction of D
- (d,t) Duals, TT-STs (%)

TIP: I-4400 / I-4700 WBS: 34232.1.1

COUNTY: Buncombe DIVISION: 13

DATE: 02-14-2012

PREPARED BY: Keith Dixon

LOCATION: I-26 from I-40 in Buncombe Co. to US 25 in Henderson Co.

PROJECT: Widen I-26



Vicinity Maps

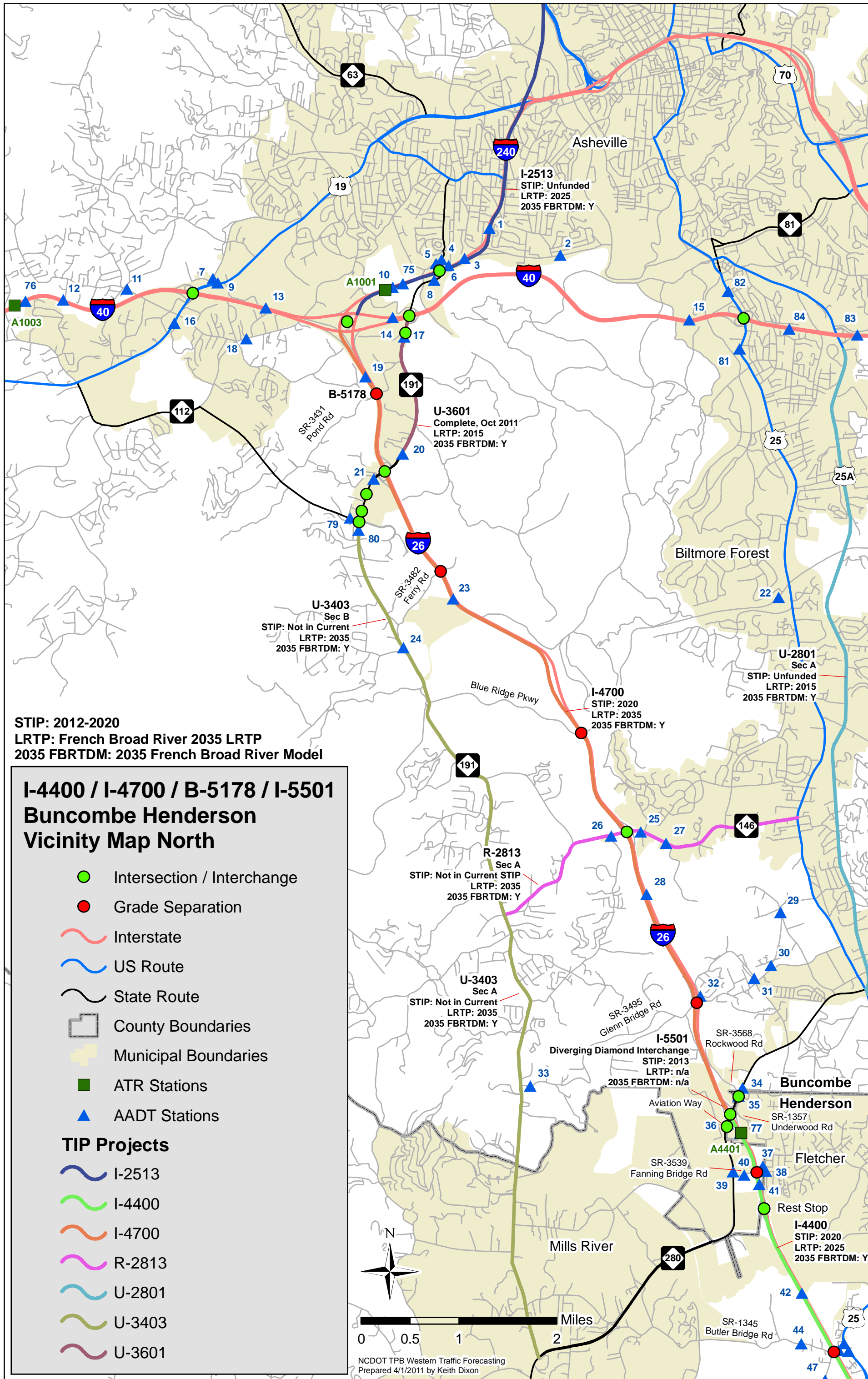

I-4400 / I-4700 / B-5178 / I-5501 Buncombe Henderson Vicinity Map South

- Intersection / Interchange
- Grade Separation
- ~ Interstate
- ~ US Route
- ~ State Route
- County Boundaries
- State Line
- Municipal Boundaries
- ▲ AADT Stations

TIP Projects

- ~ I-4400
- ~ R-0505
- ~ R-2588
- ~ R-4430
- ~ R-5207
- ~ Balfour Parkway

STIP: 2012-2020
 LRTP: French Broad River 2035 LRTP
 2035 FBRTDM: 2035 French Broad River Model

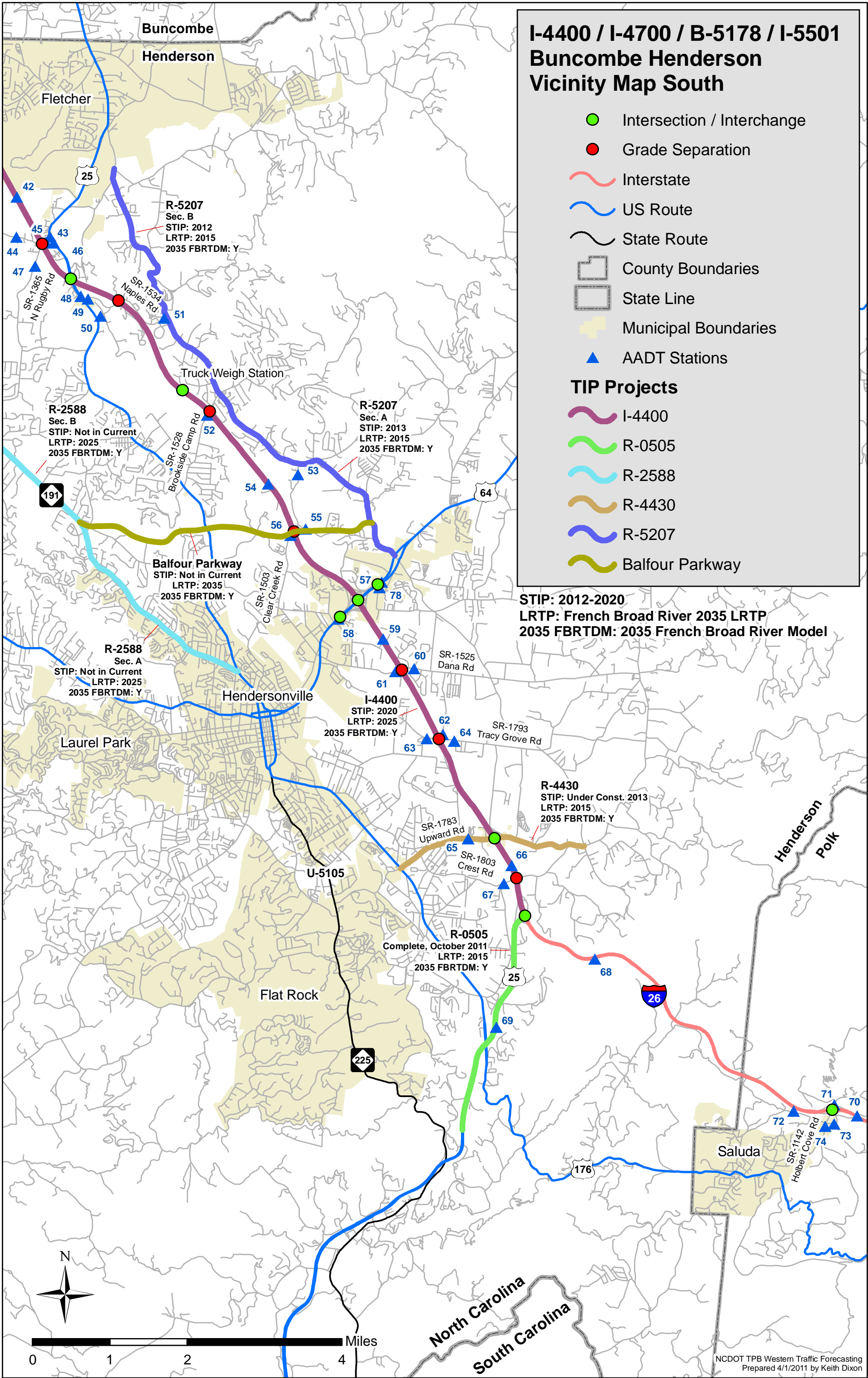

NCDOT TPB Western Traffic Forecasting
 Prepared 4/1/2011 by Keith Dixon

Appendix C – FreeVal Output

2011 No-Build

B61	Basic	0.42	68.6	15.0	13.0	0.09	0.09	0.044.3	0.044.3	0.65	0.01
US 64 - 4 SEASONS BLW/SC	Weaving	0.38	61.0	12.9	11.4	0.26	0.22	0.135.3	0.135.3	2.22	0.28
M63	Basic	0.44	68.1	15.4	13.4	0.09	0.09	0.047.5	0.047.5	0.70	0.02
M64	OnRamp	0.54	60.5	21.1	18.8	0.28	0.24	0.162.6	0.162.6	2.69	0.36
M65	Basic	0.54	69.9	18.4	16.4	2.17	2.18	1.444.2	1.444.2	20.16	0.03
D71	OnRamp	0.54	60.6	21.2	18.9	0.28	0.24	0.162.6	0.162.6	2.68	0.36
WELCH STATION NB-872	Basic	0.45	69.3	15.6	15.3	0.28	0.28	0.171.0	0.171.0	2.47	0.02
M73	OnRamp	0.54	62.8	18.5	16.5	0.27	0.24	0.162.6	0.162.6	2.59	0.27
S74	Basic	0.54	69.9	18.4	16.4	1.15	1.15	0.769.5	0.769.5	11.01	0.01
O75	OnRamp	0.55	57.2	22.5	20.0	0.30	0.26	0.162.6	0.162.6	2.84	0.34
US 25 - ADRIENNE HWY 676	Basic	0.45	64.5	16.3	14.3	0.34	0.34	0.188.3	0.188.3	2.61	0.02
M77	OnRamp	0.60	57.3	24.0	21.5	0.30	0.26	0.177.8	0.177.8	3.10	0.37
S78	Basic	0.60	65.0	21.6	19.3	1.20	1.20	0.815.1	0.815.1	12.54	0.00
O79	OnRamp	0.60	57.8	24.2	21.7	0.29	0.26	0.177.8	0.177.8	3.08	0.34
REST AREA NB-895	Basic	0.56	64.5	20.4	18.4	0.33	0.33	0.213.6	0.213.6	3.11	0.02
M81	OnRamp	0.60	58.2	23.8	21.2	0.29	0.26	0.177.8	0.177.8	3.06	0.32
M82	Basic	0.60	63.7	22.0	19.7	0.09	0.09	0.062.2	0.062.2	0.98	0.02
O83	OnRamp	0.60	57.1	24.5	21.9	0.30	0.26	0.177.8	0.177.8	3.11	0.38
NC 280 - ABBFORD RD-884	Basic	0.49	64.6	18.0	15.8	0.37	0.36	0.200.5	0.200.5	3.11	0.02
M85	OnRamp	0.75	57.1	30.2	27.4	0.30	0.26	0.226.0	0.226.0	3.96	0.48
M86	Basic	0.75	63.2	27.8	25.2	1.94	1.89	1.627.2	1.627.2	25.74	0.71
O87	OnRamp	0.75	57.0	30.8	27.9	0.30	0.26	0.226.0	0.226.0	3.97	0.49
NC 146 - LONG SHOALS-888	Basic	0.62	64.7	22.7	20.3	0.42	0.42	0.298.0	0.298.0	4.61	0.02
M89	OnRamp	0.80	54.6	24.2	21.0	0.31	0.26	0.243.2	0.243.2	4.45	0.71
M90	Basic	0.80	61.6	30.6	27.8	3.81	3.61	3.349.8	3.349.8	54.35	2.81
O91	OnRamp	0.80	51.3	36.8	33.4	0.33	0.26	0.243.3	0.243.3	4.75	1.00
NC 191 - BRISLAND RD-892	Basic	0.71	61.3	26.4	23.8	0.19	0.19	0.153.3	0.153.3	2.42	0.06
M93	OnRamp	0.85	53.5	37.3	34.1	0.32	0.26	0.259.9	0.259.9	4.86	0.86
END PROJECT NB-894	Basic	0.85	59.8	33.5	30.6	0.60	0.55	0.545.9	0.545.9	9.13	0.73
Freeway			63.9	20.3	18.2	26.92	25.77	16,987.6	16,987.6	0.266.0	0.012.9

Density-Based LOS by Segment															
Segment	1	2	3	4	5	6	7	8	9	10	11	12	13	14	15
Time Step	Basic	Off Ramp	Basic	On Ramp	Basic	Off Ramp	Basic	On Ramp	Off Ramp	Basic	On Ramp	Basic	Off Ramp	Basic	Weaving
1	A	B	A	B	A	B	B	B	B	B	B	B	B	B	B
Density-Based LOS by Segment															
Segment	16	17	18	19	20	21	22	23	24	25	26	27	28	29	30
Time Step	Basic	On Ramp	Basic	Off Ramp	Basic	On Ramp	Basic	Off Ramp	Basic	On Ramp	Basic	Off Ramp	Basic	On Ramp	Basic
1	B	C	C	C	B	B	C	C	B	C	C	C	C	C	C
Density-Based LOS by Segment															
Segment	31	32	33	34	35	36	37	38	39	40	41	42			
Time Step	Off Ramp	Basic	On Ramp	Basic	Off Ramp	Basic	On Ramp	Basic	Off Ramp	Basic	On Ramp	Basic			
1	C	B	D	D	D	C	D	D	D	E	D	D			
Demand-Based LOS by Segment															
Time Step	1	2	3	4	5	6	7	8	9	10	11	12	13	14	15
1	-	-	-	-	-	-	-	-	-	-	-	-	-	-	-
Demand-Based LOS by Segment															
Time Step	16	17	18	19	20	21	22	23	24	25	26	27	28	29	30
1	-	-	-	-	-	-	-	-	-	-	-	-	-	-	-
Demand-Based LOS by Segment															
Time Step	31	32	33	34	35	36	37	38	39	40	41	42			
1	-	-	-	-	-	-	-	-	-	-	-	-			

HCS 2010 Freeway Facilities

Project Properties

Table with 2 columns: Property Name, Value. Rows include Analyst, Analysis Date, Agency, Location, User Notes, File Name.

Facility-wide Values

Table with 2 columns: Value, Units. Row: Jam Density (pc/h/ln), 190, Time Period Duration (min), 15, Facility Length (mi), 29.10100.

Segment Input Data

Time Period 1

Mainline Data table with columns: Seg #, From, To, Type, Length, Terrain, Adj. Demand, % Trucks, % RVs, # Lanes, FFS. Rows 1-42.

Ramp Data table with columns: Seg #, Type, Adj. Demand, % Trucks, % RVs, Lanes, Accel/Decel Length, FFS. Rows 2-41.

Weaving Segment Data table with columns: Seg #, Ramp to Ramp Prop., On-Ramp, Off-Ramp, Adj. Demand, % Trucks, % RVs, Lanes, FFS. Rows 15, 35.

Time Period Independent Weaving Segment Data

Table with 7 columns: Seg #, Configuration, Short Length, # Weaving Lanes, Min. Lane Changes Freeway-Ramp, Min. Lane Changes Ramp-Freeway, Min. Lane Changes Ramp-Ramp. Row 15.

Time Period Results

Time Period 1

Main Results table with columns: Seg #, From, To, Type, Adj. Demand, Vol. Served, Capacity (pc/h), Capacity (veh/h), d/c Ratio, v/c ratio, Queue Length(ft), Avg. Speed (mi/h), Density (pc/mi/ln), Density (veh/mi/ln), Avg. Travel Time (min/veh), Free-Flow Travel Time (min/veh), Mainline Delay (min/veh), System Delay (min/veh), VHT Demand (veh-hr), VHT Volume (veh-hr), VHT (veh-hr), VHD (veh-hr), LOS. Rows 1-42.

Overall Results

Summary Results table with columns: Segment, Segment Type, Maximum d/c Ratio, Avg. Speed (mi/h), Density (pc/mi/ln), Density (veh/mi/ln), Avg. Travel Time (min/veh), Free-Flow Travel Time (min/veh), VHT Demand (veh-hr), VHT Volume (veh-hr), VHT (veh-hr), VHD (veh-hr). Rows 1-15.

B61	Basic	0.52	68.5	18.2	15.8	0.09	0.09	0.053.8	0.053.8	0.79	0.02
US 64 - 4 SEASONS BLW/SC	Weaving	0.46	59.6	16.1	14.2	0.26	0.22	0.165.3	0.165.3	2.78	0.41
M63	Basic	0.55	67.8	19.3	16.9	0.09	0.09	0.059.5	0.059.5	0.88	0.03
M64	OnRamp	0.65	59.5	25.9	23.0	0.29	0.24	0.195.2	0.195.2	3.28	0.49
M65	Basic	0.65	68.6	22.6	20.0	0.21	0.18	1.713.8	1.713.8	25.28	0.51
D71	OnRamp	0.65	60.4	25.7	22.8	0.28	0.24	0.195.2	0.195.2	3.23	0.44
WELSH STATION NB-872	Basic	0.54	69.3	18.7	18.4	0.28	0.28	0.204.9	0.204.9	2.96	0.03
M73	OnRamp	0.65	62.1	22.4	19.9	0.27	0.24	0.195.2	0.195.2	3.14	0.35
M74	Basic	0.65	68.6	22.6	20.0	0.18	0.15	0.925.8	0.925.8	13.47	0.27
D75	OnRamp	0.65	57.0	27.2	24.1	0.30	0.26	0.195.2	0.195.2	3.42	0.45
US 25 - ADRIEVILLE HWY 676	Basic	0.54	64.5	19.7	17.2	0.34	0.34	0.202.7	0.202.7	5.14	0.02
M77	OnRamp	0.71	56.3	29.3	26.1	0.30	0.26	0.212.4	0.212.4	3.77	0.50
D76	Basic	0.71	61.9	26.3	23.4	0.22	0.20	0.973.3	0.973.3	15.23	0.26
D78	OnRamp	0.71	57.8	29.0	25.9	0.29	0.26	0.212.4	0.212.4	3.67	0.41
REST AREA NB-895	Basic	0.68	64.5	24.8	22.2	0.33	0.33	0.257.3	0.257.3	3.99	0.03
M81	OnRamp	0.71	57.1	29.1	25.9	0.30	0.26	0.212.4	0.212.4	3.72	0.45
M82	Basic	0.71	61.5	26.4	23.6	0.09	0.09	0.074.3	0.074.3	1.17	0.03
D83	OnRamp	0.71	57.0	29.4	26.2	0.30	0.26	0.212.4	0.212.4	3.72	0.46
NC 280 - ABBFORD RD-884	Basic	0.60	64.6	21.9	19.2	0.37	0.36	0.243.6	0.243.6	3.77	0.03
M85	OnRamp	0.88	54.6	37.3	33.7	0.31	0.26	0.266.0	0.266.0	4.87	0.78
M86	Basic	0.88	58.6	35.4	32.0	0.09	0.09	1.915.1	1.915.1	32.69	3.23
D87	OnRamp	0.88	56.7	36.5	33.0	0.30	0.26	0.266.0	0.266.0	4.69	0.60
NC 146 - LONG SHOALS-888	Basic	0.73	63.5	27.2	24.2	0.43	0.42	0.349.1	0.349.1	5.90	0.13
M89	OnRamp	0.92	53.0	41.0	37.0	0.33	0.26	0.276.1	0.276.1	5.31	1.06
M90	Basic	0.92	57.0	37.8	34.1	0.12	0.11	3.801.5	3.801.5	66.72	6.24
D91	OnRamp	0.92	51.2	42.0	37.9	0.33	0.26	0.276.1	0.276.1	5.39	1.14
NC 191 - BRISLAND RD-892	Basic	0.82	61.1	31.6	28.3	0.20	0.19	0.176.0	0.176.0	2.88	0.17
M93	OnRamp	1.00	48.8	47.7	43.4	0.35	0.26	0.302.7	0.302.7	6.20	1.54
END PROJECT NB-894	Basic	1.00	52.4	44.7	40.6	0.68	0.55	0.635.7	0.635.7	12.13	2.35
	Freeway		61.6	25.0	22.3	27.69	25.77	20,106.7	20,106.7	0,326.3	0,026.9

Density-Based LOS by Segment															
Segment	1	2	3	4	5	6	7	8	9	10	11	12	13	14	15
Time Step	Basic	Off Ramp	Basic	On Ramp	Basic	Off Ramp	Basic	On Ramp	Off Ramp	Basic	On Ramp	Basic	Off Ramp	Basic	Weaving
1	B	B	B	B	B	B	B	B	C	B	C	C	C	C	B
Density-Based LOS by Segment															
Segment	16	17	18	19	20	21	22	23	24	25	26	27	28	29	30
Time Step	Basic	On Ramp	Basic	Off Ramp	Basic	On Ramp	Basic	Off Ramp	Basic	On Ramp	Basic	Off Ramp	Basic	On Ramp	Basic
1	C	C	C	C	C	C	C	C	C	D	D	D	C	D	D
Density-Based LOS by Segment															
Segment	31	32	33	34	35	36	37	38	39	40	41	42			
Time Step	Off Ramp	Basic	On Ramp	Basic	Off Ramp	Basic	On Ramp	Basic	Off Ramp	Basic	On Ramp	Basic			
1	D	C	E	E	E	D	E	E	E	D	E	E			
Demand-Based LOS by Segment															
Time Step	1	2	3	4	5	6	7	8	9	10	11	12	13	14	15
1	-	-	-	-	-	-	-	-	-	-	-	-	-	-	-
Demand-Based LOS by Segment															
Time Step	16	17	18	19	20	21	22	23	24	25	26	27	28	29	30
1	-	-	-	-	-	-	-	-	-	-	-	-	-	-	-
Demand-Based LOS by Segment															
Time Step	31	32	33	34	35	36	37	38	39	40	41	42			
1	-	-	-	-	-	-	-	-	-	-	-	-			

-B13	Basic	0.75	63.3	27.2	24.2	0.09	0.09	0,078.3	0,076.1	1.20	0.03
-D14	OffRamp	0.75	56.3	30.5	27.2	0.30	0.26	0,223.8	0,217.3	3.86	0.52
REST AREA SB-B15	Basic	0.72	64.2	25.6	22.9	0.31	0.30	0,246.6	0,240.1	3.74	0.05
-H16	OnRamp	0.75	56.8	30.1	26.8	0.30	0.26	0,223.8	0,217.3	3.82	0.48
-B17	Basic	0.75	63.6	27.1	24.1	0.26	0.23	1,051.8	1,021.4	16.07	0.36
-D18	OffRamp	0.75	55.0	31.3	27.8	0.31	0.26	0,223.8	0,217.3	3.95	0.61
US 25 - ADM'TL14 HWY 619	Basic	0.58	64.4	20.8	18.2	0.37	0.36	0,234.3	0,229.9	3.57	0.03
-H20	OnRamp	0.70	56.7	28.0	24.8	0.30	0.26	0,206.6	0,204.5	3.61	0.46
-B21	Basic	0.68	67.9	24.0	21.2	0.14	0.11	0,940.1	0,930.7	13.71	0.41
-D22	OffRamp	0.68	58.5	27.8	24.6	0.29	0.24	0,206.6	0,204.5	3.50	0.58
WEIGH STATION SB-B23	Basic	0.57	69.0	19.5	19.1	0.25	0.24	0,191.2	0,187.5	2.72	0.04
-H24	OnRamp	0.68	60.8	26.2	23.2	0.28	0.24	0,206.6	0,204.5	3.36	0.44
-B25	Basic	0.68	67.9	24.0	21.2	0.28	0.21	1,872.2	1,834.5	27.32	0.62
-D26	OffRamp	0.68	58.9	27.6	24.5	0.29	0.24	0,206.6	0,204.5	3.47	0.55
-B27	Basic	0.60	68.0	21.2	18.5	0.10	0.10	0,072.0	0,071.6	1.05	0.03
US 64 - 4 SEASONS BL-W33	Weaving	0.54	56.3	21.7	19.3	0.28	0.23	0,195.2	0,190.9	3.39	0.66
-B34	Basic	0.59	66.3	21.3	18.5	0.04	0.04	0,026.5	0,026.2	0.40	0.02
-H35	OnRamp	0.65	60.0	25.3	22.2	0.28	0.24	0,194.3	0,191.8	3.20	0.46
-B36	Basic	0.65	68.7	22.3	19.6	0.22	0.18	1,735.9	1,713.1	24.93	0.46
-D37	OffRamp	0.65	58.5	26.2	23.1	0.29	0.24	0,194.3	0,191.8	3.28	0.54
UPWARD RD-B38	Basic	0.53	69.5	18.1	15.5	0.38	0.37	0,240.0	0,235.2	3.39	0.03
-H39	OnRamp	0.60	61.3	22.6	19.7	0.26	0.23	0,169.4	0,166.0	2.71	0.34
-D40	OffRamp	0.60	57.7	24.4	21.3	0.28	0.23	0,169.4	0,166.0	2.88	0.51
US 25 SYSTEM (DOWNS)	Basic	0.42	69.6	14.4	12.5	0.45	0.44	0,227.3	0,224.5	3.23	0.02
-H42	OnRamp	0.43	63.5	15.7	13.7	0.27	0.24	0,126.3	0,123.6	1.95	0.18
-B43	Basic	0.43	70.0	14.3	12.4	0.51	0.51	1,821.5	1,781.6	25.45	0.00
-D44	OffRamp	0.43	59.5	16.8	14.6	0.29	0.24	0,126.3	0,123.6	2.08	0.31
HOLBERT COVE RD-B45	Basic	0.39	69.6	13.5	11.6	0.42	0.42	0,201.3	0,199.4	2.86	0.02
-H46	OnRamp	0.42	62.2	15.9	13.8	0.27	0.24	0,125.4	0,123.6	1.99	0.22
END PROJECT SB-B47	Basic	0.42	70.0	14.3	12.4	0.86	0.86	0,441.3	0,435.0	6.22	0.00
Freeway			61.4	25.9	23.1	27.68	25.65	21,181.8	20,662.3	0,336.4	0.029.0

Density-Based LOS by Segment															
Segment	1	2	3	4	5	6	7	8	9	10	11	12	13	14	15
Time Step	Basic	Off Ramp	Basic	On Ramp	Basic	Off Ramp	Basic	On Ramp	Basic	Off Ramp	Basic	On Ramp	Basic	Off Ramp	Basic
1	E	E	D	E	E	E	D	E	E	E	C	D	D	D	C
Density-Based LOS by Segment															
Segment	16	17	18	19	20	21	22	23	24	25	26	27	28	29	30
Time Step	On Ramp	Basic	Off Ramp	Basic	On Ramp	Basic	Off Ramp	Basic	On Ramp	Basic	Off Ramp	Basic	Weaving	Basic	On Ramp
1	D	D	D	C	C	C	C	C	C	C	C	C	C	C	C
Density-Based LOS by Segment															
Segment	31	32	33	34	35	36	37	38	39	40	41	42			
Time Step	Basic	Off Ramp	Basic	On Ramp	Off Ramp	Basic	On Ramp	Basic	Off Ramp	Basic	On Ramp	Basic			
1	C	C	C	C	C	B	B	B	B	B	B	B			
Demand-Based LOS by Segment															
Time Step	1	2	3	4	5	6	7	8	9	10	11	12	13	14	15
1	F	F	-	-	-	-	-	-	-	-	-	-	-	-	-
Demand-Based LOS by Segment															
Time Step	16	17	18	19	20	21	22	23	24	25	26	27	28	29	30
1	-	-	-	-	-	-	-	-	-	-	-	-	-	-	-
Demand-Based LOS by Segment															
Time Step	31	32	33	34	35	36	37	38	39	40	41	42			
1	-	-	-	-	-	-	-	-	-	-	-	-			

-B13	Basic	0.58	63.5	21.4	19.1	0.09	0.09	0.060.3	0.060.3	0.05	0.02
-D14	OffRamp	0.58	57.8	23.5	21.0	0.29	0.26	0.172.2	0.172.2	2.98	0.33
REST AREA SB-B15	Basic	0.54	64.5	19.8	17.8	0.30	0.30	0.187.3	0.187.3	2.90	0.02
-H16	OnRamp	0.58	58.3	23.0	20.5	0.29	0.26	0.172.2	0.172.2	2.96	0.31
-B17	Basic	0.58	63.0	20.9	18.7	1.23	1.23	0.809.5	0.809.5	12.45	0.00
-D18	OffRamp	0.58	56.7	23.9	21.4	0.30	0.26	0.172.2	0.172.2	3.04	0.39
US 25 - ADRIENTIA HWY 619	Basic	0.43	64.5	15.6	13.7	0.37	0.36	0.173.6	0.173.6	2.69	0.02
-H20	OnRamp	0.53	57.8	21.2	18.9	0.29	0.26	0.157.0	0.157.0	2.71	0.30
-B21	Basic	0.52	70.0	17.8	15.8	1.11	1.11	0.714.2	0.714.2	10.21	0.00
-D22	OffRamp	0.52	60.6	20.5	18.2	0.28	0.24	0.157.0	0.157.0	2.59	0.35
WEIGH STATION SB-B23	Basic	0.43	69.2	15.1	14.8	0.25	0.24	0.145.6	0.145.6	2.10	0.02
-H24	OnRamp	0.52	62.4	18.0	16.0	0.27	0.24	0.157.0	0.157.0	2.51	0.27
-B25	Basic	0.52	70.0	17.8	15.8	2.21	2.21	1.423.1	1.423.1	20.34	0.01
-D31	OffRamp	0.52	62.7	19.8	17.6	0.27	0.24	0.157.0	0.157.0	2.50	0.26
-B32	Basic	0.45	68.7	15.9	14.0	0.10	0.10	0.054.4	0.054.4	0.79	0.02
US 64 - 4 SEASONS BL-W33	Weaving	0.42	58.4	14.4	12.8	0.27	0.23	0.148.4	0.148.4	2.54	0.42
-B34	Basic	0.42	66.9	15.2	13.3	0.04	0.04	0.018.9	0.018.9	0.28	0.01
-H35	OnRamp	0.48	61.2	18.7	16.5	0.28	0.24	0.144.0	0.144.0	2.35	0.30
-B36	Basic	0.48	70.0	16.4	14.5	2.18	2.18	1.286.1	1.286.1	18.37	0.00
-D37	OffRamp	0.48	60.5	19.0	16.8	0.28	0.24	0.144.0	0.144.0	2.38	0.32
UPWARD RD-R38	Basic	0.38	69.6	13.2	11.4	0.38	0.37	0.172.1	0.172.1	2.47	0.02
-H39	OnRamp	0.44	62.1	17.1	15.0	0.26	0.23	0.126.2	0.126.2	2.03	0.23
-D40	OffRamp	0.44	61.7	17.3	15.1	0.26	0.23	0.126.2	0.126.2	2.04	0.24
US 25 SYSTEM (DOW-841)	Basic	0.30	69.7	10.4	9.0	0.44	0.44	0.162.7	0.162.7	2.33	0.01
-H42	OnRamp	0.31	63.8	11.5	10.0	0.27	0.24	0.090.8	0.090.8	1.42	0.13
-B43	Basic	0.31	70.0	10.5	9.1	3.51	3.51	1.309.6	1.309.6	18.71	0.00
-D44	OffRamp	0.31	61.2	12.0	10.4	0.28	0.24	0.090.8	0.090.8	1.48	0.19
HOLBERT COVE RD-845	Basic	0.27	69.7	9.3	8.0	0.42	0.42	0.137.4	0.137.4	1.97	0.01
-H46	OnRamp	0.29	62.6	11.1	9.6	0.27	0.24	0.085.8	0.085.8	1.37	0.15
END PROJECT SB-B47	Basic	0.29	70.0	9.9	8.6	0.86	0.86	0.302.0	0.302.0	4.32	0.00
Freeway			64.0	19.6	17.5	26.70	25.65	16,341.8	16,341.8	0,255.1	0,011.6

Density-Based LOS by Segment															
Segment	1	2	3	4	5	6	7	8	9	10	11	12	13	14	15
Time Step	Basic	Off Ramp	Basic	On Ramp	Basic	Off Ramp	Basic	On Ramp	Basic	Off Ramp	Basic	On Ramp	Basic	Off Ramp	Basic
1	D	E	C	D	D	D	C	D	D	D	B	C	C	C	C
Density-Based LOS by Segment															
Segment	16	17	18	19	20	21	22	23	24	25	26	27	28	29	30
Time Step	On Ramp	Basic	Off Ramp	Basic	On Ramp	Basic	Off Ramp	Basic	On Ramp	Basic	Off Ramp	Basic	Weaving	Basic	On Ramp
1	C	C	C	B	C	B	C	B	B	B	B	B	B	B	B
Density-Based LOS by Segment															
Segment	31	32	33	34	35	36	37	38	39	40	41	42			
Time Step	Basic	Off Ramp	Basic	On Ramp	Off Ramp	Basic	On Ramp	Basic	Off Ramp	Basic	On Ramp	Basic			
1	B	B	B	B	B	A	B	A	B	A	B	A			
Demand-Based LOS by Segment															
Segment	1	2	3	4	5	6	7	8	9	10	11	12	13	14	15
1	-	-	-	-	-	-	-	-	-	-	-	-	-	-	-
Demand-Based LOS by Segment															
Segment	16	17	18	19	20	21	22	23	24	25	26	27	28	29	30
1	-	-	-	-	-	-	-	-	-	-	-	-	-	-	-
Demand-Based LOS by Segment															
Segment	31	32	33	34	35	36	37	38	39	40	41	42			
1	-	-	-	-	-	-	-	-	-	-	-	-			

2011 Build 6 Lane

B61	Basic	0.29	69.2	10.2	8.9	0.09	0.09	0.046.0	0.046.0	0.66	0.01
US 64 - 4 SEASONS BLWISC	Weaving	0.30	62.1	9.9	8.8	0.25	0.22	0.142.5	0.142.5	2.30	0.26
M63	Basic	0.31	68.3	10.9	9.6	0.09	0.09	0.051.1	0.051.1	0.75	0.02
M64	OnRamp	0.39	61.4	14.6	13.1	0.27	0.24	0.178.5	0.178.5	2.81	0.26
M65	Basic	0.39	70.0	13.4	12.0	2.16	2.18	1.585.5	1.585.5	22.68	0.00
D71	OnRamp	0.39	64.4	14.5	13.0	0.26	0.24	0.178.5	0.178.5	2.77	0.22
WELSH STATION NB-872	Basic	0.33	69.6	11.4	11.2	0.28	0.28	0.188.7	0.188.7	2.71	0.02
M73	OnRamp	0.39	65.0	13.1	11.7	0.26	0.24	0.178.5	0.178.5	2.75	0.20
M74	Basic	0.39	70.0	13.4	12.0	1.15	1.15	0.844.8	0.844.8	12.07	0.00
D75	OnRamp	0.40	60.5	15.5	13.8	0.28	0.26	0.178.5	0.178.5	2.95	0.20
US 25 - ADRIEVILLE HWY 676	Basic	0.33	64.7	12.0	10.7	0.34	0.34	0.189.0	0.189.0	2.92	0.01
M77	OnRamp	0.44	59.6	17.1	15.4	0.29	0.26	0.198.9	0.198.9	3.34	0.28
D76	Basic	0.44	65.0	15.9	14.4	1.20	1.20	0.911.5	0.911.5	14.02	0.00
D78	OnRamp	0.44	61.4	16.9	15.2	0.28	0.26	0.198.9	0.198.9	3.24	0.18
REST AREA NB-885	Basic	0.42	64.8	15.1	13.7	0.33	0.33	0.239.0	0.239.0	3.69	0.01
M81	OnRamp	0.44	60.3	17.0	15.3	0.28	0.26	0.198.9	0.198.9	3.30	0.24
M82	Basic	0.44	64.1	16.2	14.6	0.09	0.09	0.069.6	0.069.6	1.09	0.02
D83	OnRamp	0.44	60.8	17.1	15.4	0.28	0.26	0.198.9	0.198.9	3.27	0.21
NC 280 - ABBOTTS RD-884	Basic	0.38	64.8	13.8	12.4	0.36	0.36	0.235.8	0.235.8	3.64	0.01
M85	OnRamp	0.58	59.4	22.4	20.5	0.29	0.26	0.263.1	0.263.1	4.43	0.38
M86	Basic	0.58	65.0	20.8	19.0	1.89	1.89	1.894.6	1.894.6	29.15	0.00
D87	OnRamp	0.58	60.6	22.3	20.4	0.28	0.26	0.263.1	0.263.1	4.24	0.29
NC 146 - LONG SHOALS-888	Basic	0.50	64.8	18.0	16.3	0.42	0.42	0.359.1	0.359.1	5.94	0.02
M89	OnRamp	0.63	58.1	25.4	23.2	0.29	0.26	0.290.8	0.290.8	5.00	0.53
M90	Basic	0.63	64.9	23.0	21.0	3.62	3.61	4.002.9	4.002.9	61.69	0.11
D91	OnRamp	0.63	56.0	26.6	24.4	0.30	0.26	0.290.8	0.290.8	5.19	0.72
NC 191 - BRISLAND RD-892	Basic	0.56	63.9	20.6	18.8	0.19	0.19	0.183.4	0.183.4	2.87	0.05
M93	OnRamp	0.65	58.1	26.0	23.9	0.29	0.26	0.297.4	0.297.4	5.12	0.54
END PROJECT NB-894	Basic	0.65	64.8	23.5	21.5	0.55	0.55	0.624.6	0.624.6	9.64	0.01
Freeway			65.5	15.9	14.3	26.36	25.77	18,894.0	18,894.0	0,288.4	0,006.3

Density-Based LOS by Segment															
Segment	1	2	3	4	5	6	7	8	9	10	11	12	13	14	15
Time Step	Basic	Off Ramp	Basic	On Ramp	Basic	Off Ramp	Basic	On Ramp	Off Ramp	Basic	On Ramp	Basic	Off Ramp	Basic	Weaving
1	A	B	A	B	A	B	B	B	B	A	B	B	B	B	A
Density-Based LOS by Segment															
Segment	16	17	18	19	20	21	22	23	24	25	26	27	28	29	30
Time Step	Basic	On Ramp	Basic	Off Ramp	Basic	On Ramp	Basic	Off Ramp	Basic	On Ramp	Basic	Off Ramp	Basic	On Ramp	Basic
1	A	B	B	B	B	B	B	B	B	B	B	B	B	B	B
Density-Based LOS by Segment															
Segment	31	32	33	34	35	36	37	38	39	40	41	42			
Time Step	Off Ramp	Basic	On Ramp	Basic	Off Ramp	Basic	On Ramp	Basic	Off Ramp	Basic	On Ramp	Basic			
1	B	B	C	C	C	B	C	C	C	C	C	C			
Demand-Based LOS by Segment															
Time Step	1	2	3	4	5	6	7	8	9	10	11	12	13	14	15
1	-	-	-	-	-	-	-	-	-	-	-	-	-	-	-
Demand-Based LOS by Segment															
Time Step	16	17	18	19	20	21	22	23	24	25	26	27	28	29	30
1	-	-	-	-	-	-	-	-	-	-	-	-	-	-	-
Demand-Based LOS by Segment															
Time Step	31	32	33	34	35	36	37	38	39	40	41	42			
1	-	-	-	-	-	-	-	-	-	-	-	-			

B61	Basic	0.36	69.2	12.4	10.8	0.09	0.09	0.055.9	0.055.9	0.81	0.01
US 64 - 4 SEASONS BLW/SC	Weaving	0.36	60.6	12.5	11.0	0.26	0.22	0.174.2	0.174.2	2.88	0.39
M63	Basic	0.39	68.0	13.7	12.0	0.09	0.09	0.063.8	0.063.8	0.94	0.03
M64	OnRamp	0.47	63.1	17.6	15.7	0.27	0.24	0.212.6	0.212.6	3.37	0.33
M65	Basic	0.47	70.0	16.0	14.3	2.16	2.16	1.888.3	1.888.3	26.98	0.00
D71	OnRamp	0.47	64.4	17.3	15.5	0.26	0.24	0.212.6	0.212.6	3.30	0.26
WELCH STATION NB-872	Basic	0.39	69.6	13.6	13.3	0.28	0.28	0.224.3	0.224.3	3.22	0.02
M73	OnRamp	0.47	64.7	15.7	14.0	0.26	0.24	0.212.6	0.212.6	3.29	0.25
M74	Basic	0.47	70.0	16.0	14.3	1.15	1.15	1.006.2	1.006.2	14.37	0.00
D75	OnRamp	0.48	60.5	18.5	16.5	0.28	0.26	0.212.6	0.212.6	3.51	0.28
US 25 - ADRIEVILLE HWY 676	Basic	0.40	64.7	14.4	12.7	0.34	0.34	0.224.9	0.224.9	3.47	0.01
M77	OnRamp	0.52	59.1	20.4	18.3	0.29	0.26	0.234.7	0.234.7	3.97	0.36
D76	Basic	0.52	65.0	18.9	16.9	1.20	1.20	1.075.5	1.075.5	16.55	0.00
D78	OnRamp	0.52	61.4	20.0	17.9	0.28	0.26	0.234.7	0.234.7	3.62	0.21
REST AREA NB-895	Basic	0.50	64.8	18.0	16.3	0.33	0.33	0.284.4	0.284.4	4.39	0.02
M81	OnRamp	0.52	59.9	20.3	18.2	0.28	0.26	0.234.7	0.234.7	3.92	0.31
M82	Basic	0.52	64.0	19.2	17.2	0.09	0.09	0.082.1	0.082.1	1.28	0.02
D83	OnRamp	0.52	60.8	20.2	18.1	0.28	0.26	0.234.7	0.234.7	3.86	0.25
NC 280 - ABBOTTS RD-884	Basic	0.46	64.8	16.6	14.7	0.36	0.36	0.281.4	0.281.4	4.34	0.02
M85	OnRamp	0.67	58.5	26.6	24.2	0.29	0.26	0.306.1	0.306.1	5.24	0.53
M86	Basic	0.67	64.6	24.4	22.3	1.90	1.89	2.204.0	2.204.0	34.14	0.24
D87	OnRamp	0.67	60.3	26.2	23.8	0.28	0.26	0.306.1	0.306.1	5.07	0.36
NC 146 - LONG SHOALS-888	Basic	0.58	64.8	20.9	18.8	0.42	0.42	0.414.9	0.414.9	6.40	0.02
M89	OnRamp	0.71	57.4	29.0	26.4	0.30	0.26	0.326.2	0.326.2	5.68	0.66
M90	Basic	0.71	63.9	26.3	24.0	3.67	3.61	4.491.8	4.491.8	70.31	1.20
D91	OnRamp	0.71	56.0	30.0	27.3	0.30	0.26	0.326.2	0.326.2	5.83	0.81
NC 191 - BRISLAND RD-892	Basic	0.64	63.9	23.5	21.3	0.19	0.19	0.207.8	0.207.8	3.25	0.06
M93	OnRamp	0.75	57.2	30.5	27.9	0.30	0.26	0.341.6	0.341.6	5.98	0.72
END PROJECT NB-894	Basic	0.75	63.2	27.7	25.3	0.57	0.55	0.717.4	0.717.4	11.34	0.31
Freeway			65.2	18.8	16.9	26.48	25.77	22,148.8	22,148.8	0,339.9	0,009.5

Density-Based LOS by Segment															
Segment	1	2	3	4	5	6	7	8	9	10	11	12	13	14	15
Time Step	Basic	Off Ramp	Basic	On Ramp	Basic	Off Ramp	Basic	On Ramp	Off Ramp	Basic	On Ramp	Basic	Off Ramp	Basic	Weaving
1	B	B	B	B	B	B	B	B	C	B	B	B	B	B	B

Density-Based LOS by Segment															
Segment	16	17	18	19	20	21	22	23	24	25	26	27	28	29	30
Time Step	Basic	On Ramp	Basic	Off Ramp	Basic	On Ramp	Basic	Off Ramp	Basic	On Ramp	Basic	Off Ramp	Basic	On Ramp	Basic
1	B	B	B	B	B	B	B	B	B	C	C	C	B	B	C

Density-Based LOS by Segment														
Segment	31	32	33	34	35	36	37	38	39	40	41	42		
Time Step	Off Ramp	Basic	On Ramp	Basic	Off Ramp	Basic	On Ramp	Basic	Off Ramp	Basic	On Ramp	Basic		
1	C	B	C	C	C	C	D	D	D	C	D	D		

Demand-Based LOS by Segment															
Time Step	1	2	3	4	5	6	7	8	9	10	11	12	13	14	15
1	-	-	-	-	-	-	-	-	-	-	-	-	-	-	-

Demand-Based LOS by Segment															
Time Step	16	17	18	19	20	21	22	23	24	25	26	27	28	29	30
1	-	-	-	-	-	-	-	-	-	-	-	-	-	-	-

Demand-Based LOS by Segment														
Time Step	31	32	33	34	35	36	37	38	39	40	41	42		
1	-	-	-	-	-	-	-	-	-	-	-	-		

-B13	Basic	0.56	63.8	20.5	18.3	0.09	0.09	0,087.3	0,087.3	1.37	0.02
-D14	OffRamp	0.56	61.3	21.3	19.1	0.28	0.26	0,249.5	0,249.5	4.07	0.23
REST AREA SB-B15	Basic	0.53	64.7	19.3	17.3	0.30	0.30	0,275.2	0,275.2	4.25	0.02
-H16	OnRamp	0.56	59.7	21.7	19.4	0.29	0.26	0,249.5	0,249.5	4.18	0.34
-B17	Basic	0.56	65.0	20.1	18.0	1.23	1.23	1,172.7	1,172.7	18.04	0.05
-D18	OffRamp	0.56	59.9	21.8	19.6	0.28	0.26	0,249.5	0,249.5	4.17	0.33
US 25 - ADRIENTHILL HWY E19	Basic	0.43	64.7	15.6	13.8	0.36	0.36	0,262.9	0,262.9	4.06	0.02
-H20	OnRamp	0.51	59.4	20.0	17.8	0.29	0.26	0,227.4	0,227.4	3.83	0.33
-B21	Basic	0.51	65.0	18.4	16.4	1.19	1.19	1,034.7	1,034.7	15.92	0.00
-D22	OffRamp	0.51	60.6	19.8	17.6	0.28	0.26	0,227.4	0,227.4	3.95	0.28
WEIGH STATION SB-B23	Basic	0.43	64.6	15.6	15.4	0.26	0.26	0,211.4	0,211.4	3.27	0.02
-H24	OnRamp	0.51	60.1	18.0	16.0	0.28	0.26	0,227.4	0,227.4	3.78	0.28
-B25	Basic	0.50	70.0	17.1	15.2	2.21	2.21	2,061.9	2,061.9	29.46	0.00
-D26	OffRamp	0.50	66.1	18.1	16.1	0.26	0.24	0,227.4	0,227.4	3.44	0.19
-B27	Basic	0.44	69.3	15.2	13.4	0.10	0.10	0,078.9	0,078.9	1.14	0.01
US 64 - 4 SEASONS BL-W33	Weaving	0.43	57.5	15.4	13.7	0.28	0.23	0,208.6	0,208.6	3.63	0.65
-B34	Basic	0.41	66.6	14.9	13.0	0.04	0.04	0,027.7	0,027.7	0.42	0.02
-H35	OnRamp	0.45	63.6	16.8	14.8	0.27	0.24	0,200.9	0,200.9	3.16	0.29
-B36	Basic	0.45	70.0	15.3	13.5	2.18	2.18	1,794.9	1,794.9	25.64	0.00
-D37	OffRamp	0.45	64.1	16.7	14.7	0.27	0.24	0,200.9	0,200.9	3.13	0.26
UPWARD RD-R38	Basic	0.37	69.7	12.6	10.8	0.37	0.37	0,246.7	0,246.7	3.54	0.01
-H39	OnRamp	0.41	63.8	15.3	13.3	0.25	0.23	0,172.7	0,172.7	2.71	0.24
-D40	OffRamp	0.61	61.3	23.9	20.9	0.26	0.23	0,172.7	0,172.7	2.82	0.35
US 25 SYSTEM (DOWNSHIFT)	Basic	0.43	69.7	14.9	13.0	0.44	0.44	0,233.5	0,233.5	3.35	0.01
-H42	OnRamp	0.44	63.4	16.5	14.4	0.27	0.24	0,129.8	0,129.8	2.05	0.19
-B43	Basic	0.44	70.0	15.0	13.1	3.51	3.51	1,870.7	1,870.7	26.72	0.00
-D44	OffRamp	0.44	61.3	17.1	14.9	0.28	0.24	0,129.8	0,129.8	2.12	0.26
HOLBERT COVE RD-B45	Basic	0.41	69.7	14.0	12.1	0.42	0.42	0,207.2	0,207.2	2.97	0.01
-H46	OnRamp	0.43	62.2	16.7	14.5	0.27	0.24	0,128.8	0,128.8	2.07	0.23
END PROJECT SB-B47	Basic	0.43	70.0	14.9	13.0	0.86	0.86	0,453.3	0,453.3	6.48	0.00
Freeway			64.6	20.3	18.2	0.53	0.53	23,541.1	23,541.1	0,364.2	0.011.4

Density-Based LOS by Segment															
Segment	1	2	3	4	5	6	7	8	9	10	11	12	13	14	15
Time Step	Basic	Off Ramp	Basic	On Ramp	Basic	Off Ramp	Basic	On Ramp	Basic	Off Ramp	Basic	On Ramp	Basic	Off Ramp	Basic
1	D	D	C	D	D	D	C	D	C	D	B	C	C	C	C
Density-Based LOS by Segment															
Segment	16	17	18	19	20	21	22	23	24	25	26	27	28	29	30
Time Step	On Ramp	Basic	Off Ramp	Basic	On Ramp	Basic	Off Ramp	Basic	On Ramp	Basic	Off Ramp	Basic	Weaving	Basic	On Ramp
1	C	C	C	B	B	C	B	C	B	B	B	B	B	B	B
Density-Based LOS by Segment															
Segment	31	32	33	34	35	36	37	38	39	40	41	42			
Time Step	Basic	Off Ramp	Basic	On Ramp	Off Ramp	Basic	On Ramp	Basic	Off Ramp	Basic	On Ramp	Basic			
1	B	B	B	B	C	B	B	C	B	B	B	B			
Demand-Based LOS by Segment															
Time Step	1	2	3	4	5	6	7	8	9	10	11	12	13	14	15
1	-	-	-	-	-	-	-	-	-	-	-	-	-	-	-
Demand-Based LOS by Segment															
Time Step	16	17	18	19	20	21	22	23	24	25	26	27	28	29	30
1	-	-	-	-	-	-	-	-	-	-	-	-	-	-	-
Demand-Based LOS by Segment															
Time Step	31	32	33	34	35	36	37	38	39	40	41	42			
1	-	-	-	-	-	-	-	-	-	-	-	-			

-B13	Basic	0.42	64.0	15.5	13.9	0.09	0.09	0,065.5	0,066.5	1.04	0.02
-D14	OffRamp	0.42	61.3	16.2	14.6	0.28	0.26	0,190.1	0,190.1	3.10	0.18
REST AREA SB-B15	Basic	0.40	64.7	14.4	13.0	0.30	0.30	0,206.9	0,206.9	3.20	0.01
-H16	OnRamp	0.42	60.4	16.2	14.6	0.28	0.26	0,190.1	0,190.1	3.15	0.22
-B17	Basic	0.42	65.0	15.3	13.7	1.23	1.23	0,093.6	0,093.6	13.75	0.05
-D18	OffRamp	0.42	59.8	16.6	14.0	0.29	0.26	0,190.1	0,190.1	3.18	0.26
US 25 - ADRIENTIA HWY E19	Basic	0.31	64.7	11.4	10.0	0.36	0.36	0,191.7	0,191.7	2.96	0.01
-H20	OnRamp	0.38	60.0	14.7	13.1	0.28	0.26	0,169.7	0,169.7	2.83	0.22
-B21	Basic	0.37	70.0	12.7	11.4	1.11	1.11	0,772.3	0,772.3	11.04	0.00
-D22	OffRamp	0.37	64.4	13.9	12.4	0.26	0.24	0,169.7	0,169.7	2.64	0.21
WEIGH STATION SB-B23	Basic	0.31	69.5	10.9	10.7	0.25	0.24	0,158.0	0,158.0	2.27	0.02
-H24	OnRamp	0.37	64.8	12.5	11.1	0.26	0.24	0,169.7	0,169.7	2.62	0.20
-B25	Basic	0.37	70.0	12.7	11.4	2.21	2.21	1,539.0	1,539.0	21.99	0.00
-D31	OffRamp	0.37	66.0	13.5	12.1	0.26	0.24	0,169.7	0,169.7	2.57	0.15
-B32	Basic	0.32	69.3	11.2	9.9	0.10	0.10	0,058.3	0,058.3	0.84	0.01
US 64 - 4 SEASONS BL-W33	Weaving	0.35	59.0	11.1	9.9	0.27	0.23	0,155.3	0,155.3	2.63	0.41
-B34	Basic	0.29	67.0	10.3	8.9	0.04	0.04	0,019.1	0,019.1	0.29	0.01
-H35	OnRamp	0.32	69.2	11.9	10.4	0.27	0.24	0,143.4	0,143.4	2.23	0.18
-B36	Basic	0.32	70.0	10.9	9.6	2.18	2.18	1,281.0	1,281.0	18.30	0.00
-D37	OffRamp	0.32	63.9	12.0	10.5	0.27	0.24	0,143.4	0,143.4	2.25	0.20
UPWARD RD-B38	Basic	0.25	69.7	8.6	7.4	0.37	0.37	0,168.5	0,168.5	2.42	0.01
-H39	OnRamp	0.29	64.4	10.8	9.4	0.25	0.23	0,123.2	0,123.2	1.91	0.15
-D40	OffRamp	0.44	61.7	17.0	14.8	0.26	0.23	0,123.2	0,123.2	2.00	0.24
US 25 SYSTEM (DOW-841)	Basic	0.29	69.7	10.1	8.7	0.44	0.44	0,157.0	0,157.0	2.25	0.01
-H42	OnRamp	0.30	63.8	11.1	9.7	0.27	0.24	0,087.7	0,087.7	1.37	0.12
-B43	Basic	0.30	70.0	10.2	8.8	3.51	3.51	1,264.5	1,264.5	18.06	0.00
-D44	OffRamp	0.30	61.2	11.6	10.1	0.28	0.24	0,087.7	0,087.7	1.43	0.18
HOLBERT COVE RD-B45	Basic	0.26	69.7	9.0	7.7	0.42	0.42	0,132.0	0,132.0	1.89	0.01
-H46	OnRamp	0.28	62.6	10.7	9.3	0.27	0.24	0,082.7	0,082.7	1.32	0.14
END PROJECT SB-B47	Basic	0.28	70.0	9.6	8.3	0.86	0.86	0,291.0	0,291.0	4.16	0.00
Freeway			65.5	15.2	13.7	26.20	25.65	17,904.2	17,904.2	0,273.3	0.005.9

Density-Based LOS by Segment															
Segment	1	2	3	4	5	6	7	8	9	10	11	12	13	14	15
Time Step	Basic	Off Ramp	Basic	On Ramp	Basic	Off Ramp	Basic	On Ramp	Basic	Off Ramp	Basic	On Ramp	Basic	Off Ramp	Basic
1	C	C	C	C	C	C	C	C	C	C	C	B	B	B	B
Density-Based LOS by Segment															
Segment	16	17	18	19	20	21	22	23	24	25	26	27	28	29	30
Time Step	On Ramp	Basic	Off Ramp	Basic	On Ramp	Basic	Off Ramp	Basic	On Ramp	Basic	Off Ramp	Basic	Weaving	Basic	On Ramp
1	B	B	B	B	B	B	B	A	B	B	B	B	B	A	B
Density-Based LOS by Segment															
Segment	31	32	33	34	35	36	37	38	39	40	41	42			
Time Step	Basic	Off Ramp	Basic	On Ramp	Off Ramp	Basic	On Ramp	Basic	Off Ramp	Basic	On Ramp	Basic			
1	A	B	A	B	B	A	B	A	B	A	B	A			
Demand-Based LOS by Segment															
Time Step	1	2	3	4	5	6	7	8	9	10	11	12	13	14	15
1	-	-	-	-	-	-	-	-	-	-	-	-	-	-	-
Demand-Based LOS by Segment															
Time Step	16	17	18	19	20	21	22	23	24	25	26	27	28	29	30
1	-	-	-	-	-	-	-	-	-	-	-	-	-	-	-
Demand-Based LOS by Segment															
Time Step	31	32	33	34	35	36	37	38	39	40	41	42			
1	-	-	-	-	-	-	-	-	-	-	-	-			

2011 Build 8 Lane

B61	Basic	0.22	69.8	7.7	6.7	0.09	0.09	0.046.6	0.046.6	0.67	0.00
US 64 - 4 SEASONS BLW/SC	Weaving	0.24	63.0	8.0	7.1	0.25	0.22	0.145.1	0.145.1	2.30	0.23
M63	Basic	0.24	68.5	8.3	7.3	0.09	0.09	0.052.3	0.052.3	0.76	0.02
M64	OnRamp	0.30	65.0	11.0	9.9	0.26	0.24	0.183.2	0.183.2	2.82	0.20
M65	Basic	0.30	70.0	10.3	9.2	2.16	2.18	1.627.1	1.627.1	23.24	0.00
D71	OnRamp	0.30	67.4	10.7	9.6	0.25	0.24	0.183.2	0.183.2	2.72	0.10
WELCH STATION NB-872	Basic	0.25	69.8	8.8	8.6	0.28	0.28	0.193.9	0.193.9	2.78	0.01
M73	OnRamp	0.30	66.2	9.9	8.9	0.26	0.24	0.183.2	0.183.2	2.77	0.15
S74	Basic	0.30	70.0	10.3	9.2	1.15	1.15	0.867.0	0.867.0	12.39	0.00
O75	OnRamp	0.31	63.1	13.4	10.2	0.27	0.26	0.183.2	0.183.2	2.50	0.09
US 25 - ADRIAN HWY 676	Basic	0.26	64.9	9.3	8.2	0.34	0.34	0.195.0	0.195.0	5.00	0.01
M77	OnRamp	0.34	60.8	12.9	11.7	0.28	0.26	0.204.9	0.204.9	3.37	0.22
S78	Basic	0.34	65.0	12.3	11.1	1.20	1.20	0.939.1	0.939.1	14.45	0.00
O79	OnRamp	0.34	64.1	12.5	11.2	0.27	0.26	0.204.9	0.204.9	3.19	0.04
REST AREA NB-895	Basic	0.32	64.9	11.5	10.5	0.33	0.33	0.244.3	0.244.3	3.76	0.00
M81	OnRamp	0.34	61.6	12.8	11.5	0.28	0.26	0.204.9	0.204.9	3.33	0.18
M82	Basic	0.34	64.3	12.4	11.2	0.09	0.09	0.071.7	0.071.7	1.11	0.01
O83	OnRamp	0.34	63.4	12.6	11.4	0.27	0.26	0.204.9	0.204.9	3.23	0.08
NC 280 - ABBOTSD RD-884	Basic	0.30	64.9	10.7	9.6	0.36	0.36	0.244.6	0.244.6	3.77	0.01
M85	OnRamp	0.45	60.7	17.0	15.5	0.28	0.26	0.272.3	0.272.3	4.48	0.29
M86	Basic	0.45	65.0	16.1	14.7	1.89	1.89	1.960.6	1.960.6	30.16	0.00
O87	OnRamp	0.45	63.1	16.6	15.2	0.27	0.26	0.272.3	0.272.3	4.31	0.12
NC 146 - LONG SHOALS-888	Basic	0.39	64.9	14.0	12.7	0.42	0.42	0.373.6	0.373.6	5.76	0.01
M89	OnRamp	0.49	59.8	19.2	17.6	0.28	0.26	0.302.3	0.302.3	5.05	0.40
M90	Basic	0.49	65.0	17.8	16.4	3.61	3.61	4.161.3	4.161.3	64.02	0.00
O91	OnRamp	0.49	59.3	19.6	18.0	0.29	0.26	0.302.3	0.302.3	5.10	0.45
NC 191 - BRISLAND RD-892	Basic	0.44	64.3	16.0	14.6	0.19	0.19	0.190.6	0.190.6	2.96	0.03
M93	OnRamp	0.50	60.0	19.5	17.9	0.28	0.26	0.306.1	0.306.1	5.11	0.40
END PROJECT NB-894	Basic	0.50	64.9	18.1	16.6	0.55	0.55	0.642.8	0.642.8	9.91	0.02
Freeway			66.0	12.7	11.5		25.77	19,394.3	19,394.3	0,293.9	0,004.2

Density-Based LOS by Segment															
Segment	1	2	3	4	5	6	7	8	9	10	11	12	13	14	15
Time Step	Basic	Off Ramp	Basic	On Ramp	Basic	Off Ramp	Basic	On Ramp	Off Ramp	Basic	On Ramp	Basic	Off Ramp	Basic	Weaving
1	A	B	A	B	A	B	B	B	A	A	A	A	A	A	A
Density-Based LOS by Segment															
Segment	16	17	18	19	20	21	22	23	24	25	26	27	28	29	30
Time Step	Basic	On Ramp	Basic	Off Ramp	Basic	On Ramp	Basic	Off Ramp	Basic	On Ramp	Basic	Off Ramp	Basic	On Ramp	Basic
1	A	B	A	B	A	A	A	B	A	B	B	B	B	B	B
Density-Based LOS by Segment															
Segment	31	32	33	34	35	36	37	38	39	40	41	42			
Time Step	Off Ramp	Basic	On Ramp	Basic	Off Ramp	Basic	On Ramp	Basic	Off Ramp	Basic	On Ramp	Basic			
1	B	A	B	B	B	B	B	B	B	B	B	C			
Demand-Based LOS by Segment															
Time Step	1	2	3	4	5	6	7	8	9	10	11	12	13	14	15
1	-	-	-	-	-	-	-	-	-	-	-	-	-	-	-
Demand-Based LOS by Segment															
Time Step	16	17	18	19	20	21	22	23	24	25	26	27	28	29	30
1	-	-	-	-	-	-	-	-	-	-	-	-	-	-	-
Demand-Based LOS by Segment															
Time Step	31	32	33	34	35	36	37	38	39	40	41	42			
1	-	-	-	-	-	-	-	-	-	-	-	-			

HCS 2010 Freeway Facilities

Project Properties

Project Properties table with columns: Analyst, Analysis Date, Agency, Location, File Name, Freeway Name, Analysis Period, PM Peak.

Facility-wide Values

Facility-wide Values table with columns: Jam Density (pc/h/ln), Time Period Duration (min), Facility Length (mi), 29.10100

Segment Input Data

Time Period 1

Mainline Data table with columns: Seg #, From, To, Type, Length, Terrain, Adj. Demand, % Trucks, % RVs, # Lanes, FFS.

Ramp Data table with columns: Seg #, Type, Adj. Demand, % Trucks, % RVs, Lanes, Accel/Decel Length, FFS.

Weaving Segment Data table with columns: Seg #, Ramp to Ramp Prop., Adj. Demand, % Trucks, % RVs, Lanes, FFS.

Time Period Independent Weaving Segment Data

Time Period Independent Weaving Segment Data table with columns: Seg #, Configuration, Short Length, # Weaving Lanes, Min. Lane Changes Freeway-Ramp, Min. Lane Changes Ramp-Freeway, Min. Lane Changes Ramp-Ramp.

Time Period Results

Time Period 1

Time Period Results table with columns: Seg #, From, To, Type, Adj. Demand, Vol. Served, Capacity (pc/h), Capacity (veh/h), d/c Ratio, v/c ratio, Queue Length(ft), Avg. Speed (mi/h), Density (pc/mi/ln), Density (veh/mi/ln), Avg. Travel Time (min/veh), Free-Flow Travel Time (min/veh), Mainline Delay (min/veh), System Delay (min/veh), VHT Demand (veh-hr), VHT Volume (veh-hr), VHT (veh-hr), VHD (veh-hr), LOS.

Overall Results

Overall Results table with columns: Segment, Segment Type, Maximum d/c Ratio, Avg. Speed (mi/h), Density (pc/mi/ln), Density (veh/mi/ln), Avg. Travel Time (min/veh), Free-Flow Travel Time (min/veh), VHT Demand (veh-hr), VHT Volume (veh-hr), VHT (veh-hr), VHD (veh-hr).

B61	Basic	0.27	69.8	9.4	8.2	0.09	0.09	0.056.6	0.056.6	0.81	0.00
US 64 - 4 SEASONS BLW/SC	Weaving	0.30	61.4	10.0	8.9	0.25	0.22	0.177.2	0.177.2	2.88	0.35
M63	Basic	0.30	68.2	10.4	9.2	0.09	0.09	0.065.1	0.065.1	0.95	0.02
M64	OnRamp	0.36	64.8	13.1	11.8	0.26	0.24	0.217.7	0.217.7	3.36	0.25
M65	Basic	0.36	70.0	12.2	10.9	2.16	2.16	1.933.8	1.933.8	27.63	0.00
D71	OnRamp	0.36	67.2	12.7	11.4	0.25	0.24	0.217.7	0.217.7	3.24	0.13
WELCH STATION NB-872	Basic	0.30	69.8	10.4	10.2	0.28	0.28	0.229.9	0.229.9	3.29	0.01
M73	OnRamp	0.36	65.9	11.8	10.5	0.26	0.24	0.217.7	0.217.7	3.30	0.19
S74	Basic	0.36	70.0	12.2	10.9	1.15	1.15	1.050.4	1.050.4	14.72	0.00
O75	OnRamp	0.36	65.9	13.6	12.2	0.27	0.26	0.217.7	0.217.7	3.46	0.11
US 25 - ADRIAN HWY 676	Basic	0.30	64.9	11.0	9.8	0.34	0.34	0.231.1	0.231.1	5.56	0.01
M77	OnRamp	0.40	60.5	15.4	13.8	0.28	0.26	0.241.1	0.241.1	3.98	0.27
S76	Basic	0.40	65.0	14.5	13.1	1.20	1.20	1.104.8	1.104.8	17.00	0.00
O79	OnRamp	0.40	64.2	14.7	13.2	0.27	0.26	0.241.1	0.241.1	3.75	0.05
REST AREA NB-895	Basic	0.38	65.0	13.7	12.4	0.33	0.33	0.290.1	0.290.1	4.47	0.00
M81	OnRamp	0.40	61.3	15.2	13.7	0.28	0.26	0.241.1	0.241.1	3.93	0.23
M82	Basic	0.40	64.3	14.7	13.2	0.09	0.09	0.084.4	0.084.4	1.31	0.01
O83	OnRamp	0.40	63.4	14.9	13.4	0.27	0.26	0.241.1	0.241.1	3.80	0.09
NC 280 - ABBOTSD RD-884	Basic	0.35	64.9	12.8	11.4	0.36	0.36	0.290.8	0.290.8	4.48	0.01
M85	OnRamp	0.52	60.3	19.9	18.2	0.28	0.26	0.315.8	0.315.8	5.24	0.38
M86	Basic	0.52	65.0	18.8	17.1	1.89	1.89	2.274.0	2.274.0	34.99	0.00
O87	OnRamp	0.52	62.7	19.4	17.7	0.27	0.26	0.315.8	0.315.8	5.04	0.18
NC 146 - LONG SHOALS-888	Basic	0.45	64.9	16.2	14.6	0.42	0.42	0.430.6	0.430.6	6.63	0.01
M89	OnRamp	0.56	59.5	21.7	19.8	0.29	0.26	0.338.6	0.338.6	5.69	0.48
M90	Basic	0.56	65.0	20.1	18.3	3.61	3.61	4.660.9	4.660.9	71.71	0.00
O91	OnRamp	0.56	59.1	22.1	20.2	0.29	0.26	0.338.6	0.338.6	5.73	0.52
NC 191 - BRISLAND RD-892	Basic	0.50	64.3	18.1	16.5	0.19	0.19	0.215.6	0.215.6	3.35	0.04
M93	OnRamp	0.57	59.4	22.6	20.7	0.29	0.26	0.351.1	0.351.1	5.91	0.51
END PROJECT NB-894	Basic	0.57	64.9	20.8	19.0	0.55	0.55	0.737.2	0.737.2	11.36	0.02
Freeway			66.0	14.9	13.4	26.21	25.77	22,685.6	22,685.6	0,343.9	0,005.3

Density-Based LOS by Segment															
Segment	1	2	3	4	5	6	7	8	9	10	11	12	13	14	15
Time Step	Basic	Off Ramp	Basic	On Ramp	Basic	Off Ramp	Basic	On Ramp	Off Ramp	Basic	On Ramp	Basic	Off Ramp	Basic	Weaving
1	B	B	B	B	B	B	B	C	A	A	B	A	B	A	B

Density-Based LOS by Segment															
Segment	16	17	18	19	20	21	22	23	24	25	26	27	28	29	30
Time Step	Basic	On Ramp	Basic	Off Ramp	Basic	On Ramp	Basic	Off Ramp	Basic	On Ramp	Basic	Off Ramp	Basic	On Ramp	Basic
1	A	B	B	B	A	B	B	B	A	B	B	B	B	B	B

Density-Based LOS by Segment														
Segment	31	32	33	34	35	36	37	38	39	40	41	42		
Time Step	Off Ramp	Basic	On Ramp	Basic	Off Ramp	Basic	On Ramp	Basic	Off Ramp	Basic	On Ramp	Basic		
1	B	B	B	C	B	B	C	C	C	C	C	C		

Demand-Based LOS by Segment															
Time Step	1	2	3	4	5	6	7	8	9	10	11	12	13	14	15
1	-	-	-	-	-	-	-	-	-	-	-	-	-	-	-

Demand-Based LOS by Segment															
Time Step	16	17	18	19	20	21	22	23	24	25	26	27	28	29	30
1	-	-	-	-	-	-	-	-	-	-	-	-	-	-	-

Demand-Based LOS by Segment														
Time Step	31	32	33	34	35	36	37	38	39	40	41	42		
1	-	-	-	-	-	-	-	-	-	-	-	-		

-B13	Basic	0.43	64.1	15.7	14.1	0.09	0.09	0.089.9	0.089.9	1.40	0.02
-D14	OffRamp	0.43	64.1	15.7	14.1	0.27	0.26	0.256.8	0.256.8	4.00	0.05
REST AREA SB-B15	Basic	0.41	64.9	14.7	13.3	0.30	0.30	0.281.6	0.281.6	4.34	0.00
-H16	OnRamp	0.43	61.1	16.3	14.6	0.28	0.26	0.256.8	0.256.8	4.20	0.25
-B17	Basic	0.43	65.0	15.5	13.9	1.23	1.23	1.207.9	1.207.9	18.57	0.00
-D18	OffRamp	0.43	62.0	16.3	14.6	0.28	0.26	0.256.8	0.256.8	4.14	0.19
US 25 - ADMITTANCE HWY 619	Basic	0.33	64.8	12.0	10.6	0.36	0.36	0.271.0	0.271.0	4.18	0.01
-H20	OnRamp	0.39	60.8	15.0	13.4	0.28	0.26	0.233.5	0.233.5	3.84	0.25
-B21	Basic	0.38	70.0	13.2	11.7	1.11	1.11	1.062.2	1.062.2	15.18	0.00
-D22	OffRamp	0.38	67.1	13.7	12.2	0.25	0.24	0.233.5	0.233.5	3.48	0.14
WEIGH STATION SB-B23	Basic	0.32	69.7	11.2	11.0	0.24	0.24	0.217.3	0.217.3	5.11	0.01
-H24	OnRamp	0.38	65.7	12.7	11.3	0.26	0.24	0.233.5	0.233.5	3.55	0.22
-B25	Basic	0.38	70.0	13.1	11.7	2.21	2.21	2.116.6	2.116.6	30.24	0.00
-D31	OffRamp	0.38	68.7	13.4	12.0	0.25	0.24	0.233.5	0.233.5	3.40	0.06
-B32	Basic	0.34	69.8	11.5	10.2	0.10	0.10	0.080.7	0.080.7	1.16	0.00
US 64 - 4 SEASONS BL-W33	Weaving	0.38	58.2	12.4	11.0	0.27	0.23	0.212.9	0.212.9	3.65	0.61
-B34	Basic	0.31	66.8	11.3	9.9	0.04	0.04	0.028.2	0.028.2	0.42	0.02
-H35	OnRamp	0.34	65.4	12.4	11.0	0.26	0.24	0.204.0	0.204.0	3.12	0.23
-B36	Basic	0.34	70.0	11.6	10.3	2.18	2.18	1.822.2	1.822.2	26.03	0.00
-D37	OffRamp	0.34	66.8	12.2	10.7	0.26	0.24	0.204.0	0.204.0	3.05	0.14
UPWARD RD-R38	Basic	0.28	69.9	9.5	8.2	0.37	0.37	0.249.6	0.249.6	3.57	0.01
-H39	OnRamp	0.31	65.9	11.2	9.7	0.25	0.23	0.173.8	0.173.8	2.64	0.16
-D40	OffRamp	0.61	61.3	24.0	21.0	0.26	0.23	0.173.8	0.173.8	2.83	0.35
US 25 SYSTEM (DOWNSHIFT)	Basic	0.29	69.7	10.0	8.7	0.44	0.44	0.235.7	0.235.7	3.38	0.01
-H42	OnRamp	0.44	63.4	16.7	14.5	0.27	0.24	0.131.0	0.131.0	2.07	0.20
-B43	Basic	0.44	70.0	15.1	13.2	3.51	3.51	1.888.1	1.888.1	26.97	0.00
-D44	OffRamp	0.44	61.3	17.3	15.0	0.28	0.24	0.131.0	0.131.0	2.14	0.27
HOLBERT COVE RD-B45	Basic	0.41	69.7	14.1	12.2	0.42	0.42	0.209.3	0.209.3	3.00	0.01
-H46	OnRamp	0.44	62.1	16.9	14.7	0.27	0.24	0.130.0	0.130.0	2.09	0.23
END PROJECT SB-B47	Basic	0.44	70.0	15.0	13.1	0.86	0.86	0.457.5	0.457.5	6.54	0.00
Freeway			66.0	16.0	14.3	26.08	25.65	24,175.7	24,175.7	0,366.4	0.005.9

Density-Based LOS by Segment															
Segment	1	2	3	4	5	6	7	8	9	10	11	12	13	14	15
Time Step	Basic	Off Ramp	Basic	On Ramp	Basic	Off Ramp	Basic	On Ramp	Basic	Off Ramp	Basic	On Ramp	Basic	Off Ramp	Basic
1	C	C	C	C	C	C	C	C	C	C	C	B	B	B	B
Density-Based LOS by Segment															
Segment	16	17	18	19	20	21	22	23	24	25	26	27	28	29	30
Time Step	On Ramp	Basic	Off Ramp	Basic	On Ramp	Basic	Off Ramp	Basic	On Ramp	Basic	Off Ramp	Basic	Weaving	Basic	On Ramp
1	B	B	B	B	B	B	B	B	B	B	B	B	B	B	B
Density-Based LOS by Segment															
Segment	31	32	33	34	35	36	37	38	39	40	41	42			
Time Step	Basic	Off Ramp	Basic	On Ramp	Off Ramp	Basic	On Ramp	Basic	Off Ramp	Basic	On Ramp	Basic			
1	B	B	A	B	C	A	B	C	A	B	B	B			
Demand-Based LOS by Segment															
Time Step	1	2	3	4	5	6	7	8	9	10	11	12	13	14	15
1	-	-	-	-	-	-	-	-	-	-	-	-	-	-	-
Demand-Based LOS by Segment															
Time Step	16	17	18	19	20	21	22	23	24	25	26	27	28	29	30
1	-	-	-	-	-	-	-	-	-	-	-	-	-	-	-
Demand-Based LOS by Segment															
Time Step	31	32	33	34	35	36	37	38	39	40	41	42			
1	-	-	-	-	-	-	-	-	-	-	-	-			

HCS 2010 Freeway Facilities

Project Properties

Table with 4 columns: Property, Value, Unit, and Date. Includes Analyst, Analysis Date, Agency, Location, User Notes, and File Name.

Facility-wide Values

Table with 2 columns: Parameter and Value. Includes Jam Density (pc/h/in) and Time Period Duration (min).

Segment Input Data

Time Period 1

Mainline Data table with columns: Seg #, From, To, Type, Length, Terrain, Adj. Demand, % Trucks, % RVs, # Lanes, FFS.

Ramp Data table with columns: Seg #, Type, Adj. Demand, % Trucks, % RVs, Lanes, Accel/Decel Length, FFS.

Weaving Segment Data table with columns: Seg #, Ramp to Ramp Prop., Adj. Demand, % Trucks, % RVs, Lanes, FFS.

Time Period Independent Weaving Segment Data

Table with 3 columns: Parameter and Value. Includes Min. Lane Changes Freeway, Min. Lane Changes Ramp, and Min. Lane Changes Ramp.

Summary table with columns: Seg #, Configuration, Short Length, # Weaving Lanes, Ramp, Freeway, Ramp.

Time Period Results

Time Period 1

Large table with 17 columns: Seg #, From, To, Type, Adj. Demand, Vol. Served, Capacity (pc/h), Capacity (veh/h), d/c Ratio, v/c ratio, Queue Length (ft), Avg. Speed (mi/h), Density (pc/mi/in), Density (veh/ml/mi), Avg. Travel Time (min/veh), Free-Flow Travel Time (min/veh), Mainline Delay (min/veh), System Delay (min/veh), VMT Demand (veh-min), VMT Volume (veh-min), VHT (veh-hrs), LOS.

Overall Results

Summary table with 12 columns: Segment, Segment Type, Maximum d/c Ratio, Avg. Speed (mi/h), Density (pc/mi/in), Density (veh/ml/mi), Avg. Travel Time (min/veh), Free-Flow Travel Time (min/veh), VMT Demand (veh-min), VMT Volume (veh-min), VHT (veh-hrs), VHD (veh-hrs).

-B9	Basic	0.43	65.0	15.6	14.2	1.84	1.84	1,841.5	1,841.5	28.33	0.00
-D10	OffRamp	0.43	60.2	16.8	15.4	0.28	0.26	0,263.1	0,263.1	4.37	0.32
NC 280 - ALBANY RD-B11	Basic	0.28	64.8	10.2	9.1	0.40	0.40	0,254.2	0,254.2	3.92	0.01
-M12	OnRamp	0.33	61.1	12.5	11.2	0.28	0.26	0,195.7	0,195.7	3.20	0.19
-B13	Basic	0.33	64.2	11.9	10.7	0.09	0.09	0,068.5	0,068.5	1.07	0.01
-D14	OffRamp	0.33	64.1	12.0	10.7	0.27	0.26	0,195.7	0,195.7	3.05	0.04
REST AREA SB- B15	Basic	0.30	64.9	11.0	10.0	0.30	0.30	0,211.3	0,211.3	3.25	0.00
-M16	OnRamp	0.33	61.6	12.3	11.0	0.28	0.26	0,195.7	0,195.7	3.18	0.16
-B17	Basic	0.33	65.0	11.8	10.6	1.23	1.23	0,919.6	0,919.6	14.15	0.00
-D18	OffRamp	0.33	61.9	12.4	11.1	0.26	0.26	0,195.7	0,195.7	3.16	0.15
US 25 - ASHEVILLE HWY-B19	Basic	0.24	64.8	8.8	7.7	0.36	0.36	0,197.4	0,197.4	3.04	0.01
-M20	OnRamp	0.29	61.3	11.1	9.9	0.28	0.26	0,173.9	0,173.9	2.84	0.16
-B21	Basic	0.29	70.0	9.8	8.7	1.11	1.11	0,791.4	0,791.4	11.31	0.00
-D22	OffRamp	0.29	67.4	10.2	9.1	0.25	0.24	0,173.9	0,173.9	2.58	0.10
WISCON STATION SB-B23	Basic	0.24	69.8	8.3	8.2	0.24	0.24	0,161.9	0,161.9	2.32	0.01
-M24	OnRamp	0.29	66.1	9.4	8.4	0.26	0.24	0,173.9	0,173.9	2.63	0.15
-B25	Basic	0.29	70.0	9.8	8.7	2.21	2.21	1,577.0	1,577.0	22.53	0.00
-D31	OffRamp	0.29	68.8	10.0	8.9	0.25	0.24	0,173.9	0,173.9	2.53	0.04
-B32	Basic	0.25	69.8	8.5	7.5	0.10	0.10	0,059.5	0,059.5	0.85	0.00
US 64 - 4 SEASONS BLVD-B33	Weaving	0.36	59.8	9.0	8.0	0.27	0.23	0,158.2	0,158.2	2.65	0.39
-B34	Basic	0.22	67.3	7.8	6.7	0.04	0.04	0,019.3	0,019.3	0.29	0.01
-M35	OnRamp	0.24	65.8	8.8	7.7	0.26	0.24	0,144.9	0,144.9	2.20	0.13
-B36	Basic	0.24	70.0	8.3	7.3	2.18	2.18	1,294.3	1,294.3	18.49	0.00
-D37	OffRamp	0.24	66.7	8.7	7.6	0.26	0.24	0,144.9	0,144.9	2.17	0.10
UPWARD RD-B38	Basic	0.19	69.8	6.5	5.6	0.37	0.37	0,169.2	0,169.2	2.42	0.01
-M39	OnRamp	0.22	66.2	7.9	6.8	0.24	0.23	0,123.0	0,123.0	1.86	0.10
-D40	OffRamp	0.44	61.7	17.0	14.8	0.26	0.23	0,123.0	0,123.0	1.99	0.24
US 25 SYSTEM IC-841	Basic	0.29	69.7	10.1	8.7	0.44	0.44	0,156.6	0,156.6	2.25	0.01
-M42	OnRamp	0.30	63.8	11.2	9.6	0.27	0.24	0,087.5	0,087.5	1.37	0.12
-B43	Basic	0.30	70.0	10.2	8.8	3.51	3.51	1,261.5	1,261.5	18.02	0.00
-D44	OffRamp	0.30	61.2	11.7	10.1	0.28	0.24	0,087.5	0,087.5	1.43	0.18
HOLBERT COVE RD- B45	Basic	0.26	69.7	9.0	7.7	0.42	0.42	0,131.6	0,131.6	1.89	0.01
-M46	OnRamp	0.28	62.6	10.7	9.2	0.27	0.24	0,082.5	0,082.5	1.32	0.14
END PROJECT SB-B47	Basic	0.28	70.0	9.7	8.3	0.86	0.86	0,290.3	0,290.3	4.15	0.00
Freeway			65.9	12.2	10.9	26.04	25.65	18,358.1	18,358.1	0,278.4	0,004.1

Density-Based LOS by Segment															
Segment	1	2	3	4	5	6	7	8	9	10	11	12	13	14	15
Time Step	Basic	Off Ramp	Basic	On Ramp	Basic	Off Ramp	Basic	On Ramp	Basic	Off Ramp	Basic	On Ramp	Basic	Off Ramp	Basic
1	B	B	B	B	B	B	B	B	B	B	A	B	B	B	A

Density-Based LOS by Segment															
Segment	16	17	18	19	20	21	22	23	24	25	26	27	28	29	30
Time Step	On Ramp	Basic	Off Ramp	Basic	On Ramp	Basic	Off Ramp	Basic	On Ramp	Basic	Off Ramp	Basic	On Ramp	Basic	On Ramp
1	B	B	B	A	B	A	A	A	A	A	A	A	A	A	A

Density-Based LOS by Segment														
Segment	31	32	33	34	35	36	37	38	39	40	41	42		
Time Step	Basic	Off Ramp	Basic	On Ramp	Off Ramp	Basic	On Ramp	Basic	Off Ramp	Basic	On Ramp	Basic		
1	A	A	A	A	B	A	A	B	A	A	B	A		

Demand-Based LOS by Segment															
Segment	1	2	3	4	5	6	7	8	9	10	11	12	13	14	15
Time Step	-	-	-	-	-	-	-	-	-	-	-	-	-	-	-
1	-	-	-	-	-	-	-	-	-	-	-	-	-	-	-

Demand-Based LOS by Segment															
Segment	16	17	18	19	20	21	22	23	24	25	26	27	28	29	30
Time Step	-	-	-	-	-	-	-	-	-	-	-	-	-	-	-
1	-	-	-	-	-	-	-	-	-	-	-	-	-	-	-

Demand-Based LOS by Segment														
Segment	31	32	33	34	35	36	37	38	39	40	41	42		
Time Step	-	-	-	-	-	-	-	-	-	-	-	-		
1	-	-	-	-	-	-	-	-	-	-	-	-		

2040 No-Build

HCS 2010 Freeway Facilities

Project Properties

Table with project details: Analyst, Analysis Date (2/8/2013 10:12:36 AM), Agency (NHTB North Carolina, PC), Location (I-26), User Notes (2040 DYNB), File Name (C:\Temp\preview.xml)

Facility-wide Values

Table with facility-wide values: Jam Density (pc/h/ln) 190, Time Period Duration (min) 15, Facility Length (mi) 29.10100

Segment Input Data

Time Period 1

Mainline Data table listing segments from 1 to 47 with columns for Seg #, From, To, Type, Length, Terrain, Adj. Demand, % Trucks, % RVs, # Lanes, FFS.

Ramp Data table listing segments with columns for Seg #, Type, Adj. Demand, % Trucks, % RVs, Lanes, Accel/Decel Length, FFS.

Weaving Segment Data table listing segments with columns for Seg #, Ramp to Ramp Prop., Adj. Demand, % Trucks, % RVs, Lanes, FFS.

Time Period Independent Weaving Segment Data

Table with weaving segment data: Seg #, Configuration, Short Length, # Weaving Lanes, Min. Lane Changes Freeway Ramp, Min. Lane Changes Ramp-Freeway, Min. Lane Changes Ramp-Ramp

Time Period Results

Time Period 1

Large table with time period results for 47 segments, including columns for Seg #, From, To, Type, Adj. Demand, Vol. Served, Capacity, d/c Ratio, v/c ratio, Queue Length, Avg. Speed, Density, Avg. Travel Time, Free-Flow Travel Time, Mainline Delay, System Delay, VMT Demand, VMT Volume, VMT (veh-hrs), VHD (veh-hrs).

Overall Results

Summary table with overall results for selected segments: Segment, Segment Type, Maximum d/c Ratio, Avg. Speed (mi/h), Density (pc/mi/ln), Density (veh/mi/ln), Avg. Travel Time (min/veh), Free-Flow Travel Time (min/veh), VMT Demand (veh-min), VMT Volume (veh-min), VMT (veh-hrs), VHD (veh-hrs)

M51	OnRamp	0.58	61.4	22.5	19.6	0.28	0.24	0.171.4	0.171.4	2.79	0.34
B52	Basic	0.58	69.6	19.9	17.3	3.84	3.82	2,690.6	2,690.6	38.66	0.22
O53	OffRamp	0.58	54.3	25.5	22.2	0.31	0.24	0.171.4	0.171.4	3.16	0.71
US 25 SPYGLASS I-95 NB	Basic	0.57	68.1	20.2	17.6	0.19	0.18	0.127.4	0.127.4	1.87	0.05
US 25 SPYGLASS I-95 SB	OnRamp	0.77	58.8	30.3	26.5	0.25	0.21	0.198.9	0.198.9	3.38	0.54
O56	OffRamp	0.77	59.6	31.0	27.1	0.25	0.21	0.198.9	0.198.9	3.34	0.50
UPWARD RD 457	Basic	0.60	69.3	20.7	17.5	0.38	0.38	0,267.6	0,267.6	3.86	0.04
M58	OnRamp	0.72	59.7	28.9	25.1	0.29	0.24	0.213.8	0.213.8	3.58	0.53
B59	Basic	0.72	66.7	26.0	22.6	2.31	2.20	1,928.2	1,928.2	28.92	1.38
O60	OffRamp	0.72	62.3	27.8	24.2	0.27	0.24	0.213.8	0.213.8	3.43	0.38
B61	Basic	0.63	68.5	22.0	18.8	0.09	0.09	0,063.9	0,063.9	0.93	0.02
US 54 + 4 SEASONS BLVD	Weaving	0.54	57.8	19.5	16.9	0.27	0.22	0.190.2	0.190.2	3.29	0.57
B63	Basic	0.62	67.4	22.1	18.8	0.09	0.09	0,066.1	0,066.1	0.98	0.04
M64	OnRamp	0.73	58.3	29.9	26.0	0.29	0.24	0.216.5	0.216.5	3.71	0.62
B65	Basic	0.73	66.4	26.4	22.9	0.16	0.15	0.133.5	0.133.5	2.01	0.10
O66	OffRamp	0.73	61.0	28.8	25.0	0.28	0.24	0.216.5	0.216.5	3.55	0.46
O67	OffRamp	0.68	52.7	30.8	26.5	0.32	0.24	0.198.0	0.198.0	3.76	0.93
BAL FOUR POXY #68	Basic	0.53	67.7	18.9	15.7	0.17	0.16	0,100.7	0,100.7	1.49	0.05
M69	OnRamp	0.75	59.8	29.6	25.8	0.29	0.24	0.221.1	0.221.1	3.70	0.54
B70	Basic	0.75	66.0	27.1	23.6	1.19	1.12	1,017.0	1,017.0	15.41	0.88
O71	OffRamp	0.75	60.0	29.8	26.0	0.28	0.24	0.221.1	0.221.1	3.69	0.53
WILSON STATION NB 872	Basic	0.61	69.2	21.0	20.5	0.28	0.28	0,229.0	0,229.0	3.31	0.04
M73	OnRamp	0.75	61.3	25.8	22.5	0.28	0.24	0.221.1	0.221.1	3.61	0.45
B74	Basic	0.75	66.0	27.1	23.6	1.22	1.15	1,046.5	1,046.5	15.86	0.91
O75	OffRamp	0.76	56.6	31.6	27.5	0.30	0.26	0.221.1	0.221.1	3.90	0.50
US 25 ASHEVILLE HWY 476	Basic	0.60	64.5	22.0	18.8	0.34	0.34	0,220.6	0,220.6	3.42	0.03
M77	OnRamp	0.84	54.5	35.3	31.0	0.31	0.26	0,244.5	0,244.5	4.48	0.72
B78	Basic	0.84	60.5	32.4	28.4	1.29	1.20	1,120.4	1,120.4	18.52	1.28
O79	OffRamp	0.84	57.7	34.0	29.8	0.30	0.26	0,244.5	0,244.5	4.24	0.48
BEST AREA NB 880	Basic	0.79	62.0	29.9	26.4	0.35	0.33	0,294.4	0,294.4	4.75	0.22
M81	OnRamp	0.84	55.3	35.1	30.8	0.31	0.26	0,244.5	0,244.5	4.42	0.66
B82	Basic	0.84	60.5	32.4	28.4	0.10	0.09	0,085.6	0,085.6	1.41	0.10
O83	OffRamp	0.84	55.7	35.2	30.9	0.31	0.26	0,244.5	0,244.5	4.39	0.63
NC 260 ADNPORT RD 884	Basic	0.58	64.5	21.3	17.9	0.37	0.36	0,226.9	0,226.9	3.52	0.03
M85	OnRamp	0.86	55.3	35.8	31.5	0.31	0.26	0,251.1	0,251.1	4.54	0.68
B86	Basic	0.86	59.7	33.7	29.6	2.06	1.89	1,807.7	1,807.7	30.28	2.47
O87	OffRamp	0.86	56.7	35.5	31.2	0.30	0.26	0,251.1	0,251.1	4.43	0.57
NC 146 - LONG SHALS- 888	Basic	0.70	64.1	25.9	22.2	0.43	0.42	0,323.4	0,323.4	5.05	0.07
M89	OnRamp	0.96	50.7	43.9	38.9	0.34	0.26	0,283.8	0,283.8	5.60	1.23
B90	Basic	0.96	54.6	41.4	36.6	4.30	3.61	3,907.1	3,907.1	71.59	11.48
O91	OffRamp	0.96	50.7	44.5	39.4	0.34	0.26	0,283.8	0,283.8	5.59	1.23
NC 191 - BREVARD RD 892	Basic	0.81	61.3	31.2	27.2	0.20	0.19	0,169.7	0,169.7	2.77	0.16
M93	OnRamp	0.94	51.1	43.0	38.0	0.33	0.26	0,277.2	0,277.2	5.43	1.16
END PROJECT NB 894	Basic	0.94	55.8	39.5	35.0	0.64	0.55	0,582.1	0,582.1	10.43	1.47
Freeway			60.8	29.0	25.4	28.29	25.77	22,609.0	22,609.0	0,371.8	0,036.4

Density-Based LOS by Segment															
Segment	1	2	3	4	5	6	7	8	9	10	11	12	13	14	15
Time Step	Basic	Off Ramp	Basic	On Ramp	Basic	Off Ramp	Basic	On Ramp	Basic	Off Ramp	Basic	On Ramp	Basic	Off Ramp	Basic
1	C	C	C	C	C	C	C	D	D	C	D	C	C	C	B
Segment	16	17	18	19	20	21	22	23	24	25	26	27	28	29	30
Time Step	Basic	On Ramp	Basic	Off Ramp	Off Ramp	Basic	On Ramp	Basic	Off Ramp	Basic	On Ramp	Basic	Off Ramp	Basic	On Ramp
1	C	D	D	D	D	C	D	D	D	C	C	D	D	C	E
Segment	31	32	33	34	35	36	37	38	39	40	41	42	43	44	45
Time Step	Basic	Off Ramp	Basic	On Ramp	Basic	Off Ramp	Basic	On Ramp	Basic	Off Ramp	Basic	On Ramp	Basic	Off Ramp	Basic
1	D	D	D	E	D	E	C	E	D	E	C	E	E	E	D
Segment	46	47													
Time Step	On Ramp	Basic													
1	E	E													
Segment	16	17	18	19	20	21	22	23	24	25	26	27	28	29	30
Time Step	-	-	-	-	-	-	-	-	-	-	-	-	-	-	-
Segment	31	32	33	34	35	36	37	38	39	40	41	42	43	44	45
Time Step	-	-	-	-	-	-	-	-	-	-	-	-	-	-	-
Segment	46	47													
Time Step	-	-													

HCS 2010 Freeway Facilities

Project Properties

Table with project details: Analyst (MCHD PROJECT NB), Analysis Date (2/8/2013 10:12:36 AM), Agency (NHTB North Carolina, PC), Location (I-26), User Notes (2040 DYNB), File Name (C:\Temp\preview.xml).

Facility-wide Values

Summary table: Jam Density (pc/h/ln) 190, Time Period Duration (min) 15, Facility Length (mi) 15, Total Volume 29.10100.

Segment Input Data

Time Period 1

Mainline Data table listing segments from 1 to 47 with columns: Seg #, From, To, Type, Length, Terrain, Adj. Demand, % Trucks, % RVs, # Lanes, FFS.

Ramp Data table listing segments from 2 to 46 with columns: Seg #, Type, Adj. Demand, % Trucks, % RVs, Lanes, Accel/Decel Length, FFS.

Weaving Segment Data table listing segments from 15 to 25 with columns: Seg #, Ramp to Ramp Prop., Adj. Demand, % Trucks, % RVs, Lanes, FFS, etc.

Time Period Independent Weaving Segment Data

Table with weaving segment data: Seg #, Configuration, Short Length, # Weaving Lanes, Min. Lane Changes Freeway-Ramp, Min. Lane Changes Ramp-Freeway, Min. Lane Changes Ramp-Ramp.

Time Period Results

Time Period 1

Main Time Period Results table with columns: Seg #, From, To, Type, Adj. Demand, Vol. Served, Capacity, d/c Ratio, v/c ratio, Queue Length, Avg. Speed, Density, Avg. Travel Time, Free-Flow Travel Time, Mainline Delay, System Delay, VMT Demand, VMT Volume, VHT, VHD.

Overall Results

Summary table for overall results: Segment, Segment Type, Maximum d/c Ratio, Avg. Speed, Density, Avg. Travel Time, Free-Flow Travel Time, VMT Demand, VMT Volume, VHT, VHD.

M51	OnRamp	0.70	60.0	28.0	24.3	0.29	0.24	0.206.7	0.209.8	3.48	0.59
B52	Basic	0.70	67.2	25.2	21.0	3.98	3.82	3,245.9	3,278.3	48.79	1.96
C53	OffRamp	0.70	59.8	28.3	24.6	0.29	0.24	0,206.7	0,208.8	3.49	0.51
US 25 SPYRITH I-95 NB	Basic	0.69	67.6	24.5	21.3	0.19	0.18	0,153.9	0,153.4	2.27	0.08
M55	OnRamp	0.94	54.6	39.4	34.3	0.27	0.21	0,341.1	0,340.1	4.39	0.96
C56	OffRamp	0.94	57.7	38.8	33.8	0.26	0.21	0,241.1	0,240.1	4.16	0.73
UPWARD RD NB	Basic	0.76	65.3	28.2	23.9	0.40	0.38	0,340.3	0,343.5	5.26	0.35
M58	OnRamp	0.91	55.6	38.1	33.1	0.31	0.24	0,270.0	0,268.5	4.83	0.99
B59	Basic	0.91	59.0	36.9	32.0	2.61	2.20	2,434.8	2,420.7	41.04	6.46
D60	OffRamp	0.91	58.4	37.2	32.4	0.29	0.24	0,270.0	0,268.5	4.60	0.76
B61	Basic	0.79	64.4	29.5	25.2	0.09	0.09	0,080.6	0,080.5	1.25	0.10
US 54 - 4 SEASONS BLVD	Weaving	0.68	55.2	29.0	25.2	0.28	0.22	0,240.1	0,238.3	4.32	0.91
B63	Basic	0.81	63.9	30.2	25.8	0.10	0.09	0,086.1	0,085.9	1.35	0.12
M64	OnRamp	0.91	53.6	40.5	35.2	0.32	0.24	0,270.8	0,272.7	5.09	1.20
B65	Basic	0.91	58.2	37.9	33.0	0.18	0.15	0,167.0	0,168.2	2.89	0.49
C66	OffRamp	0.91	58.9	37.5	32.6	0.29	0.24	0,270.8	0,272.7	4.63	0.73
D67	OffRamp	0.84	58.2	34.8	29.9	0.29	0.24	0,246.2	0,247.2	4.25	0.72
BAL FOUR PKWY NB	Basic	0.70	67.3	25.0	20.9	0.17	0.16	0,133.8	0,133.5	1.98	0.08
M69	OnRamp	0.92	55.9	38.0	33.1	0.31	0.24	0,274.5	0,272.7	4.88	0.99
B70	Basic	0.92	58.3	37.8	32.9	1.35	1.12	1,262.7	1,254.5	21.53	3.60
D71	OffRamp	0.92	57.7	38.2	33.2	0.30	0.24	0,274.5	0,272.7	4.72	0.83
WILSON STATION NB NB	Basic	0.75	65.7	27.5	26.9	0.29	0.28	0,284.4	0,284.9	4.34	0.27
M73	OnRamp	0.92	56.0	38.3	33.3	0.30	0.24	0,274.5	0,272.7	4.87	0.98
B74	Basic	0.92	58.3	37.8	32.9	1.38	1.15	1,299.3	1,290.9	22.15	3.71
D75	OffRamp	0.94	54.9	40.2	35.0	0.31	0.26	0,274.5	0,272.7	4.97	0.77
US 25 ASHEVILLE HWY NB	Basic	0.77	62.8	28.5	24.4	0.35	0.34	0,279.9	0,278.9	4.44	0.15
M77	OnRamp	1.04	50.4	45.1	39.5	0.34	0.26	0,304.5	0,294.0	5.94	1.31
B78	Basic	1.04	52.0	45.4	39.8	1.50	1.20	1,395.5	1,347.7	25.94	5.21
D79	OffRamp	1.04	56.2	42.0	36.8	0.30	0.26	0,304.5	0,294.0	5.23	0.71
BEST AREA NB SB	Basic	0.99	53.3	37.2	32.7	0.41	0.33	0,370.5	0,356.3	6.69	1.21
M81	OnRamp	1.04	49.8	47.0	41.3	0.34	0.26	0,304.5	0,294.0	5.90	1.38
B82	Basic	1.04	52.0	45.4	39.8	0.11	0.09	0,106.6	0,102.9	1.98	0.40
D83	OffRamp	1.04	54.0	43.7	38.4	0.32	0.26	0,304.5	0,294.0	5.45	0.93
NC 260 AIRPORT RD NB	Basic	0.76	63.4	27.3	23.2	0.37	0.36	0,299.1	0,288.8	4.55	0.11
M85	OnRamp	1.07	51.8	43.5	38.3	0.33	0.26	0,315.1	0,294.0	5.67	1.15
B86	Basic	1.07	50.9	40.0	35.2	2.41	1.89	2,268.9	2,083.3	40.95	8.89
D87	OffRamp	1.07	44.3	45.6	40.1	0.38	0.26	0,315.1	0,288.8	6.47	2.06
NC 146 - LONG SAL- SB	Basic	0.90	25.4	61.5	53.0	1.08	0.42	0,413.2	0,354.5	13.98	8.52
M89	OnRamp	1.17	50.2	45.0	39.8	0.34	0.26	0,344.0	0,294.0	5.86	1.34
B90	Basic	1.17	52.0	39.8	35.2	4.51	3.61	4,735.2	4,046.9	77.81	15.55
D91	OffRamp	1.17	44.5	46.5	41.1	0.38	0.26	0,344.0	0,293.8	6.60	2.08
NC 191 - BREWARD RD NB	Basic	1.01	35.4	49.2	42.9	0.35	0.19	0,209.7	0,177.1	5.01	2.28
M93	OnRamp	1.16	49.5	46.3	41.0	0.34	0.26	0,341.8	0,294.0	5.94	1.42
END PROJECT NB NB	Basic	1.16	52.5	44.5	39.4	0.68	0.55	0,717.8	0,617.5	11.76	2.26
Freeway			55.3	36.0	31.5	31.25	25.77	27,864.6	26,588.0	0,480.5	0,086.8

Density-Based LOS by Segment															
Segment	1	2	3	4	5	6	7	8	9	10	11	12	13	14	15
Time Step	Basic	Off Ramp	Basic	On Ramp	Basic	Off Ramp	Basic	On Ramp	Basic	Off Ramp	Basic	On Ramp	Basic	Off Ramp	Basic
1	C	D	C	C	C	D	C	E	E	D	E	E	E	D	D
Density-Based LOS by Segment															
Segment	16	17	18	19	20	21	22	23	24	25	26	27	28	29	30
Time Step	Basic	On Ramp	Basic	Off Ramp	Basic	On Ramp	Basic	Off Ramp	Basic	On Ramp	Basic	Off Ramp	Basic	On Ramp	Basic
1	D	E	E	E	D	C	E	E	E	D	E	E	E	D	E
Density-Based LOS by Segment															
Segment	31	32	33	34	35	36	37	38	39	40	41	42	43	44	45
Time Step	Basic	Off Ramp	Basic	On Ramp	Basic	Off Ramp	Basic	On Ramp	Basic	Off Ramp	Basic	On Ramp	Basic	Off Ramp	Basic
1	F	E	E	E	F	E	D	E	E	F	F	E	E	F	F
Density-Based LOS by Segment															
Segment	46	47													
Time Step	On Ramp	Basic													
1	E	E													
Demand-Based LOS by Segment															
Segment	1	2	3	4	5	6	7	8	9	10	11	12	13	14	15
Time Step	-	-	-	-	-	-	-	-	-	-	-	-	-	-	-
Demand-Based LOS by Segment															
Segment	16	17	18	19	20	21	22	23	24	25	26	27	28	29	30
Time Step	-	-	-	-	-	-	-	-	-	-	-	-	-	-	F
Demand-Based LOS by Segment															
Segment	31	32	33	34	35	36	37	38	39	40	41	42	43	44	45
Time Step	F	F	F	F	F	F	F	F	F	F	F	F	F	F	F
Demand-Based LOS by Segment															
Segment	46	47													
Time Step	F	F													

HCS 2010 Freeway Facilities

Project Properties table containing Analyst, Analysis Date, Agency, Location, User Notes, and File Name.

Facility-wide Values table with Jam Density (pc/h/ln), Time Period Duration (min), Facility Length (mi), and 28.95900.

Segment Input Data

Time Period 1

Mainline Data table with columns for Seg #, From, To, Type, Length, Terrain, Adj. Demand, % Trucks, % RVs, # Lanes, FFS.

Ramp Data table with columns for Seg #, Type, Adj. Demand, % Trucks, % RVs, Lanes, Accel/Decel Length, FFS.

Weaving Segment Data table with columns for Seg #, Ramp to Ramp Prop., On-Ramp (Adj. Demand, % Trucks, % RVs, Lanes, FFS), Off-Ramp (Adj. Demand, % Trucks, % RVs, Lanes, FFS).

Time Period Independent Weaving Segment Data

Table with columns: Seg #, Configuration, Short Length, # Weaving Lanes, Min. Lane Changes Freeway Ramp, Min. Lane Changes Ramp-Freeway, Min. Lane Changes Ramp-Ramp.

Time Period Results

Time Period 1

Main Time Period Results table with columns: Seg #, From, To, Type, Adj. Demand, Vol. Served, Capacity, d/c Ratio, v/c ratio, Queue Length, Avg. Speed, Density, Avg. Travel Time, Free-Flow Travel Time, Mainline Delay, System Delay, VMT Demand, VMT Volume, VHT Volume, VHD.

Overall Results

Summary table with columns: Segment, Segment Type, Maximum d/c Ratio, Avg. Speed (mi/h), Density (pc/mi/ln), Density (veh/mi/ln), Avg. Travel Time (min/veh), Free-Flow Travel Time (min/veh), VMT Demand (veh-min), VMT Volume (veh-min), VHT (veh-hrs), VHD (veh-hrs).

M4	OnRamp	1.19	50.0	45.8	40.6	0.34	0.26	0.352.1	0.294.0	5.88	1.36
B5	Basic	1.19	52.5	44.5	39.4	4.06	3.28	4,400.7	3,675.4	69.96	13.41
D6	OffRamp	1.19	54.0	43.3	38.3	0.32	0.26	0.352.1	0.294.0	5.44	0.92
NC 146 - LONG SHOALS- B7	Basic	0.92	62.7	28.8	24.9	0.45	0.44	0,443.9	0,369.3	5.89	0.21
M8	OnRamp	1.10	51.8	42.4	37.3	0.33	0.26	0.323.2	0.281.3	5.43	1.11
B9	Basic	1.10	54.7	41.1	36.2	2.18	1.84	2,262.6	1,968.8	35.97	5.68
D10	OffRamp	1.10	53.6	42.0	36.9	0.30	0.26	0.323.2	0.281.3	5.24	0.92
NC 280 - AIRPORT RD-B11	Basic	0.79	64.3	25.3	21.5	0.40	0.40	0,340.2	0,297.3	4.62	0.05
M12	OnRamp	1.07	51.8	41.8	36.7	0.33	0.26	0.312.6	0.281.3	5.43	1.11
B13	Basic	1.07	54.6	41.3	36.3	0.11	0.09	0,109.4	0,098.4	1.80	0.29
D14	OffRamp	1.07	56.2	40.1	35.2	0.30	0.26	0.312.6	0,281.3	5.00	0.88
AREA SB B15	Basic	1.02	56.4	38.7	34.1	0.35	0.30	0,345.7	0,313.6	5.56	0.74
M16	OnRamp	1.07	51.1	44.6	39.1	0.33	0.26	0.312.6	0,285.5	5.99	1.20
B17	Basic	1.07	53.7	42.6	37.4	1.49	1.23	1,469.1	1,341.9	24.97	4.33
D18	OffRamp	1.07	54.0	42.4	37.2	0.32	0.26	0.312.6	0,285.5	5.29	0.90
US 25 - ASHEVILLE HWY-B19	Basic	0.79	63.8	26.4	22.6	0.37	0.36	0,312.9	0,283.0	4.43	0.08
M20	OnRamp	0.97	53.6	38.1	33.1	0.32	0.26	0,282.6	0,259.9	4.85	0.85
B21	Basic	0.95	60.6	34.7	30.2	1.28	1.11	1,285.8	1,182.7	19.53	2.63
D22	OffRamp	0.95	57.7	36.4	31.7	0.30	0.24	0,282.6	0,259.9	4.51	0.79
WILSON STATION SB-B23	Basic	0.77	66.9	25.6	25.1	0.25	0.24	0,258.3	0,238.6	3.57	0.16
M24	OnRamp	0.95	56.6	36.6	31.9	0.30	0.24	0,282.6	0,264.2	4.67	0.90
B25	Basic	0.95	59.8	35.7	31.1	1.27	1.08	1,257.6	1,175.7	19.65	2.85
D26	OffRamp	0.95	59.0	36.2	31.5	0.29	0.24	0,282.6	0,264.2	4.47	0.70
D27	OffRamp	0.89	57.9	34.2	29.5	0.29	0.24	0,261.8	0,242.8	4.39	0.72
BALFOUR PROXY-B28	Basic	0.73	67.7	24.3	20.4	0.17	0.16	0,139.2	0,130.7	1.93	0.06
M29	OnRamp	0.94	56.8	36.3	31.6	0.30	0.24	0,278.9	0,264.2	4.65	0.88
B30	Basic	0.94	59.8	35.8	31.1	0.27	0.23	0,265.0	0,251.0	4.20	0.61
D31	OffRamp	0.94	58.7	36.4	31.7	0.29	0.24	0,278.9	0,264.2	4.50	0.73
B32	Basic	0.85	63.9	30.1	25.8	0.11	0.10	0,098.9	0,093.8	1.47	0.13
US 84 - 4 SEASONS BL-W33	Weaving	0.75	53.3	30.4	26.5	0.30	0.23	0,267.9	0,254.5	4.78	1.14
B34	Basic	0.86	63.4	30.8	26.5	0.04	0.04	0,037.7	0,035.8	0.56	0.05
M35	OnRamp	0.94	54.3	39.5	34.3	0.31	0.24	0,278.1	0,268.5	4.94	1.11
B36	Basic	0.94	59.0	36.8	32.0	2.58	2.18	2,484.6	2,398.3	40.65	6.39
D37	OffRamp	0.94	58.0	37.5	32.6	0.29	0.24	0,278.1	0,268.5	4.63	0.79
UPWARD RD-B38	Basic	0.79	65.8	27.4	23.2	0.40	0.37	0,349.0	0,333.2	5.06	0.30
M39	OnRamp	0.96	54.6	39.8	34.7	0.30	0.23	0,272.8	0,263.1	4.87	1.06
D40	OffRamp	0.96	56.9	39.3	34.3	0.28	0.23	0,272.0	0,263.1	4.62	0.86
US 25 - STYER RD-B41	Basic	0.72	67.2	25.2	21.9	0.46	0.44	0,388.4	0,379.3	5.65	0.23
M42	OnRamp	0.73	61.1	27.7	24.0	0.28	0.24	0,215.3	0,208.8	3.42	0.44
B43	Basic	0.73	67.2	25.2	21.9	3.66	3.51	3,103.5	3,010.3	44.80	1.79
D44	OffRamp	0.73	59.4	28.5	24.8	0.29	0.24	0,215.3	0,208.8	3.52	0.53
HOLBERT COVE RD- B45	Basic	0.69	68.2	23.4	20.2	0.43	0.42	0,351.0	0,339.8	4.98	0.13
M46	OnRamp	0.73	59.9	27.9	24.3	0.28	0.24	0,216.9	0,208.8	3.48	0.50
END PROJECT SB-B47	Basic	0.73	67.2	25.2	21.9	0.89	0.86	0,763.5	0,735.0	10.94	0.44
Freeway			57.3	35.5	31.1	30.01	25.65	28,651.0	26,035.6	0,454.7	0,069.3

Density-Based LOS by Segment															
Segment	1	2	3	4	5	6	7	8	9	10	11	12	13	14	15
Time Step	Basic	Off Ramp	Basic	On Ramp	Basic	Off Ramp	Basic	On Ramp	Basic	Off Ramp	Basic	On Ramp	Basic	Off Ramp	Basic
1	E	F	F	F	E	E	D	E	E	E	C	E	E	E	E
Density-Based LOS by Segment															
Segment	16	17	18	19	20	21	22	23	24	25	26	27	28	29	30
Time Step	On Ramp	Basic	Off Ramp	Basic	On Ramp	Basic	Off Ramp	Basic	On Ramp	Basic	Off Ramp	Off Ramp	Basic	On Ramp	Basic
1	E	E	E	E	D	E	D	E	C	E	E	E	D	C	E
Density-Based LOS by Segment															
Segment	31	32	33	34	35	36	37	38	39	40	41	42	43	44	45
Time Step	Off Ramp	Basic	Weaving	Basic	On Ramp	Basic	Off Ramp	Basic	On Ramp	Basic	Off Ramp	Basic	On Ramp	Basic	Off Ramp
1	E	D	D	D	E	E	E	D	E	E	C	C	C	D	C
Density-Based LOS by Segment															
Segment	46	47													
Time Step	On Ramp	Basic													
1	C	C													
Demand-Based LOS by Segment															
Time Step	1	2	3	4	5	6	7	8	9	10	11	12	13	14	15
1	F	F	F	F	F	F	F	F	F	F	F	F	F	F	F
Demand-Based LOS by Segment															
Time Step	16	17	18	19	20	21	22	23	24	25	26	27	28	29	30
1	F	F	F	F	F	F	F	F	F	F	F	F	F	F	F
Demand-Based LOS by Segment															
Time Step	31	32	33	34	35	36	37	38	39	40	41	42	43	44	45
1	-	-	-	-	-	-	-	-	-	-	-	-	-	-	-
Demand-Based LOS by Segment															
Time Step	46	47													
1	-	-													

HCS 2010 Freeway Facilities

Project Properties

Table with Project Properties including Analyst, Analysis Date, Agency, Location, User Notes, and File Name.

Facility-wide Values

Table with Facility-wide Values including Jam Density, Time Period Duration, Facility Length, and Average Speed.

Segment Input Data

Time Period 1

Mainline Data table with columns: Seg #, From, To, Type, Length, Terrain, Adj. Demand, % Trucks, % RVs, # Lanes, FFS.

Ramp Data table with columns: Seg #, Type, Adj. Demand, % Trucks, % RVs, Lanes, Accel/Decel Length, FFS.

Weaving Segment Data table with columns: Seg #, Ramp to Ramp Prop., On-Ramp, Off-Ramp, Adj. Demand, % Trucks, % RVs, Lanes, FFS.

Time Period Independent Weaving Segment Data

Table with Weaving Segment Data including Seg #, Configuration, Short Length, # Weaving Lanes, Min. Lane Changes Freeway, Min. Lane Changes Ramp-Freeway, Min. Lane Changes Ramp-Ramp.

Time Period Results

Time Period 1

Large table with Time Period Results including Seg #, From, To, Type, Adj. Demand, Vol. Served, Capacity, d/c Ratio, v/c ratio, Queue Length, Avg. Speed, Density, Avg. Travel Time, Free-Flow Travel Time, Mainline Delay, System Delay, VMT Demand, VMT Volume, VHT, and LOS.

Overall Results

Table with Overall Results including Segment, Segment Type, Maximum d/c Ratio, Avg. Speed, Density, Avg. Travel Time, Free-Flow Travel Time, VMT Demand, VMT Volume, VHT, and VHD.

M4	OnRamp	0.98	50.0	45.8	40.6	0.34	0.26	0.290.5	0.290.5	5.81	1.34
B5	Basic	0.98	53.4	43.2	38.3	3.99	3.28	3,631.0	3,631.0	68.06	12.20
D6	OffRamp	0.98	55.7	41.4	36.7	0.31	0.26	0.290.5	0.290.5	5.22	0.75
NC 146 - LONG SHOALS- B7	Basic	0.73	63.7	26.8	23.1	0.45	0.44	0,348.0	0,348.0	5.47	0.11
M8	OnRamp	0.88	53.6	38.2	33.6	0.32	0.26	0,257.7	0,257.7	4.81	0.85
B9	Basic	0.88	58.7	35.2	30.9	2.03	1.84	1,804.2	1,804.2	30.73	2.97
D10	OffRamp	0.88	55.5	37.2	32.7	0.31	0.26	0,257.7	0,257.7	4.64	0.68
NC 280 - AIRPORT RD-B11	Basic	0.61	64.6	22.1	18.6	0.40	0.40	0,258.8	0,258.8	4.01	0.03
M12	OnRamp	0.86	53.8	36.9	32.4	0.32	0.26	0,251.1	0,251.1	4.67	0.80
B13	Basic	0.86	59.6	33.8	29.7	0.10	0.09	0,087.9	0,087.9	1.47	0.12
D14	OffRamp	0.86	57.7	34.9	30.6	0.30	0.26	0,251.1	0,251.1	4.35	0.49
AREA SB B15	Basic	0.81	61.3	31.2	27.5	0.32	0.30	0,275.1	0,275.1	4.49	0.26
M16	OnRamp	0.86	54.8	36.4	31.9	0.31	0.26	0,251.1	0,251.1	4.59	0.72
B17	Basic	0.86	59.6	33.8	29.7	1.34	1.23	1,180.3	1,180.3	19.80	1.64
D18	OffRamp	0.86	55.9	36.1	31.6	0.30	0.26	0,251.1	0,251.1	4.49	0.63
US 25 - ASHEVILLE HWY-B19	Basic	0.63	64.5	22.9	19.5	0.37	0.36	0,247.0	0,247.0	3.83	0.03
M20	OnRamp	0.78	55.5	32.8	28.5	0.31	0.26	0,227.8	0,227.8	4.11	0.60
B21	Basic	0.77	65.2	28.3	24.6	1.19	1.11	1,036.4	1,036.4	15.89	1.09
D22	OffRamp	0.77	59.9	30.8	26.8	0.28	0.24	0,227.8	0,227.8	3.80	0.55
WILSON STATION SB-B23	Basic	0.62	69.0	21.7	21.2	0.25	0.24	0,208.1	0,208.1	3.02	0.04
M24	OnRamp	0.77	60.6	26.9	23.4	0.28	0.24	0,227.8	0,227.8	3.76	0.50
B25	Basic	0.77	65.2	28.3	24.6	1.16	1.08	1,013.6	1,013.6	15.54	1.06
D26	OffRamp	0.77	61.1	30.2	26.3	0.28	0.24	0,227.8	0,227.8	3.73	0.48
D27	OffRamp	0.72	53.4	32.9	28.4	0.32	0.24	0,213.6	0,213.6	4.04	0.91
BALFOUR PROXY-B28	Basic	0.56	67.7	19.7	16.4	0.17	0.16	0,105.1	0,105.1	1.55	0.05
M29	OnRamp	0.75	59.6	30.1	26.1	0.29	0.24	0,232.2	0,232.2	3.74	0.56
B30	Basic	0.75	65.7	27.5	23.9	0.25	0.23	0,212.0	0,212.0	3.23	0.20
D31	OffRamp	0.75	62.6	28.9	25.1	0.27	0.24	0,222.2	0,222.2	3.57	0.38
B32	Basic	0.68	67.9	24.0	20.6	0.10	0.10	0,079.3	0,079.3	1.17	0.04
US 14 - 4 SEASONS BL-W33	Weaving	0.61	55.6	22.3	19.4	0.29	0.23	0,214.2	0,214.2	3.85	0.80
B34	Basic	0.66	66.1	24.1	20.6	0.04	0.04	0,029.0	0,029.0	0.44	0.02
M35	OnRamp	0.75	58.4	30.5	26.5	0.29	0.24	0,220.5	0,220.5	3.78	0.63
B36	Basic	0.75	66.0	27.1	23.5	2.31	2.18	1,970.0	1,970.0	29.87	1.72
D37	OffRamp	0.75	60.2	29.8	25.8	0.28	0.24	0,220.5	0,220.5	3.67	0.52
UPWARD RD-B38	Basic	0.62	69.0	21.6	18.3	0.38	0.37	0,275.0	0,275.0	3.98	0.06
M39	OnRamp	0.79	58.3	32.4	28.3	0.28	0.23	0,224.3	0,224.3	3.85	0.65
D40	OffRamp	0.79	61.1	31.2	27.2	0.27	0.23	0,224.3	0,224.3	3.67	0.47
US 25 - STYER RD-B41	Basic	0.60	69.4	20.6	18.0	0.45	0.44	0,321.8	0,321.8	4.64	0.04
M42	OnRamp	0.60	62.3	23.1	20.2	0.27	0.24	0,178.7	0,178.7	2.87	0.31
B43	Basic	0.60	69.3	20.8	18.2	3.55	3.51	2,576.2	2,576.2	37.17	0.37
D44	OffRamp	0.60	61.1	23.6	20.6	0.28	0.24	0,178.7	0,178.7	2.82	0.37
HOLBERT COVE RD- B45	Basic	0.56	69.7	19.2	16.7	0.42	0.42	0,285.7	0,285.7	4.10	0.02
M46	OnRamp	0.59	61.2	23.1	20.1	0.28	0.24	0,175.6	0,175.6	2.87	0.36
END PROJECT SB-B47	Basic	0.59	69.4	20.5	17.8	0.86	0.86	0,618.0	0,618.0	8.90	0.07
Freeway			60.3	30.1	26.4	28.37	25.65	23,182.0	23,182.0	0,384.3	0,040.5

Density-Based LOS by Segment															
Segment	1	2	3	4	5	6	7	8	9	10	11	12	13	14	15
Time Step	Basic	Off Ramp	Basic	On Ramp	Basic	Off Ramp	Basic	On Ramp	Basic	Off Ramp	Basic	On Ramp	Basic	Off Ramp	Basic
1	E	E	D	E	E	E	D	E	E	E	C	E	D	D	D
Density-Based LOS by Segment															
Segment	16	17	18	19	20	21	22	23	24	25	26	27	28	29	30
Time Step	On Ramp	Basic	Off Ramp	Basic	On Ramp	Basic	Off Ramp	Basic	On Ramp	Basic	Off Ramp	Off Ramp	Basic	On Ramp	Basic
1	E	D	E	E	C	D	D	D	C	C	D	D	D	D	D
Density-Based LOS by Segment															
Segment	31	32	33	34	35	36	37	38	39	40	41	42	43	44	45
Time Step	Off Ramp	Basic	Weaving	Basic	On Ramp	Basic	Off Ramp	Basic	On Ramp	Basic	Off Ramp	Basic	On Ramp	Basic	Off Ramp
1	D	C	C	C	C	D	D	D	C	D	D	C	C	C	C
Density-Based LOS by Segment															
Segment	46	47													
Time Step	On Ramp	Basic													
1	C	C													
Demand-Based LOS by Segment															
Time Step	1	2	3	4	5	6	7	8	9	10	11	12	13	14	15
1	-	-	-	-	-	-	-	-	-	-	-	-	-	-	-
Demand-Based LOS by Segment															
Time Step	16	17	18	19	20	21	22	23	24	25	26	27	28	29	30
1	-	-	-	-	-	-	-	-	-	-	-	-	-	-	-
Demand-Based LOS by Segment															
Time Step	31	32	33	34	35	36	37	38	39	40	41	42	43	44	45
1	-	-	-	-	-	-	-	-	-	-	-	-	-	-	-
Demand-Based LOS by Segment															
Time Step	46	47													
1	-	-													

2040 Build 6 Lane

M51	OnRamp	0.60	61.2	23.5	20.5	0.20	0.24	0.178.3	0.178.3	2.92	0.37
B52	Basic	0.60	69.3	20.8	18.1	3.86	3.82	2,799.9	2,799.9	40.39	0.39
O53	OffRamp	0.60	54.3	26.5	23.1	0.31	0.24	0.178.3	0.178.3	3.28	0.74
US 25 SOUTH I-85	Basic	0.60	68.1	21.0	18.3	0.19	0.18	0.132.6	0.132.6	1.95	0.05
US 25 NORTH I-85	OnRamp	0.82	59.8	31.8	27.8	0.25	0.21	0.212.2	0.212.2	3.55	0.52
O56	OffRamp	0.55	59.2	22.2	19.4	0.25	0.21	0.212.2	0.212.2	3.59	0.55
UPWARD RD 857	Basic	0.45	69.4	15.7	13.4	0.38	0.38	0,306.3	0,306.3	4.41	0.04
M58	OnRamp	0.56	63.2	21.3	18.6	0.27	0.24	0.252.6	0.252.6	4.00	0.39
B59	Basic	0.56	69.7	19.4	17.0	2.20	2.20	2,277.2	2,277.2	32.66	0.13
O60	OffRamp	0.56	66.0	20.5	18.0	0.26	0.24	0.252.6	0.252.6	3.83	0.22
B61	Basic	0.50	69.2	17.2	14.9	0.09	0.09	0,076.8	0,076.8	1.11	0.01
US 54 + 4 SEASONS BLVD	Weaving	0.48	58.4	17.0	14.9	0.27	0.22	0.226.6	0.226.6	3.88	0.64
B63	Basic	0.50	67.5	17.8	15.4	0.09	0.09	0,081.0	0,081.0	1.20	0.04
M64	OnRamp	0.59	62.3	22.6	19.9	0.27	0.24	0.265.6	0.265.6	4.26	0.47
B65	Basic	0.59	68.9	20.5	18.1	0.15	0.15	0.163.8	0.163.8	2.38	0.04
O66	OffRamp	0.59	65.2	21.7	19.1	0.26	0.24	0.265.6	0.265.6	4.07	0.28
O67	OffRamp	0.56	57.2	23.6	20.6	0.30	0.24	0.251.4	0.251.4	4.40	0.81
BALFOUR POKY RD	Basic	0.46	68.3	16.1	13.7	0.17	0.16	0.133.2	0.133.2	1.95	0.05
M69	OnRamp	0.62	62.6	23.7	20.9	0.27	0.24	0.282.1	0.282.1	4.50	0.47
B70	Basic	0.62	69.0	21.7	19.2	1.14	1.12	1,297.7	1,297.7	18.81	0.27
O71	OffRamp	0.62	64.0	23.4	20.7	0.27	0.24	0.282.1	0.282.1	4.41	0.38
WILSON STATION NB 872	Basic	0.52	69.5	17.9	17.6	0.28	0.28	0,295.8	0,295.8	4.25	0.03
M73	OnRamp	0.62	63.7	21.1	18.7	0.27	0.24	0.282.1	0.282.1	4.43	0.40
B74	Basic	0.62	69.0	21.7	19.2	1.17	1.15	1,335.3	1,335.3	19.35	0.28
O75	OffRamp	0.64	60.1	24.9	22.0	0.28	0.26	0.282.1	0.282.1	4.69	0.35
US 25 ASHEVILLE HWY 476	Basic	0.52	64.7	19.0	16.6	0.34	0.34	0,293.3	0,293.3	4.53	0.02
M77	OnRamp	0.68	58.0	27.0	24.0	0.29	0.26	0.301.1	0.301.1	5.19	0.56
B78	Basic	0.68	64.5	24.6	21.9	1.21	1.20	1,379.9	1,379.9	21.40	0.17
O79	OffRamp	0.68	61.1	26.0	23.1	0.28	0.26	0.301.1	0.301.1	4.93	0.30
BEST AREA NB 880	Basic	0.64	64.7	23.2	20.8	0.33	0.33	0,362.6	0,362.6	5.60	0.02
M81	OnRamp	0.68	58.7	26.7	23.8	0.29	0.26	0.301.1	0.301.1	5.13	0.49
B82	Basic	0.68	63.8	24.9	22.2	0.09	0.09	0,105.4	0,105.4	1.65	0.03
O83	OffRamp	0.68	59.4	26.8	23.8	0.29	0.26	0.301.1	0.301.1	5.07	0.44
NC 260 AIRPORT RD 884	Basic	0.52	64.7	18.9	16.4	0.36	0.36	0,312.7	0,312.7	4.83	0.02
M85	OnRamp	0.73	57.8	29.2	26.1	0.29	0.26	0.326.1	0.326.1	5.64	0.62
B86	Basic	0.73	63.6	26.9	24.1	1.93	1.89	2,347.7	2,347.7	36.90	0.78
O87	OffRamp	0.73	59.9	28.6	25.5	0.28	0.26	0.326.1	0.326.1	5.44	0.42
NC 146 - LONG SIGNAL 888	Basic	0.61	64.8	22.0	19.3	0.42	0.42	0,426.3	0,426.3	6.58	0.02
M89	OnRamp	0.78	56.5	32.2	28.8	0.30	0.26	0.350.5	0.350.5	6.21	0.82
B90	Basic	0.78	62.3	29.5	26.4	3.77	3.61	4,825.2	4,825.2	77.45	3.21
O91	OffRamp	0.78	55.6	33.0	29.6	0.31	0.26	0.350.5	0.350.5	6.38	0.91
NC 191 - BREWARD RD 892	Basic	0.68	63.8	24.9	22.1	0.19	0.19	0.215.3	0.215.3	3.37	0.06
M93	OnRamp	0.76	57.1	31.3	28.0	0.30	0.26	0.342.2	0.342.2	6.00	0.73
END PROJECT NB 894	Basic	0.76	62.8	28.5	25.6	0.57	0.55	0,718.6	0,718.6	11.44	0.38
Freeway			64.4	23.7	21.0	26.89	25.77	27,254.0	27,254.0	0,423.3	0,018.4

Density-Based LOS by Segment															
Segment	1	2	3	4	5	6	7	8	9	10	11	12	13	14	15
Time Step	Basic	Off Ramp	Basic	On Ramp	Basic	Off Ramp	Basic	On Ramp	Basic	Off Ramp	Basic	On Ramp	Basic	Off Ramp	Basic
1	C	C	C	C	C	C	C	D	C	B	C	C	C	C	B
Density-Based LOS by Segment															
Segment	16	17	18	19	20	21	22	23	24	25	26	27	28	29	30
Time Step	Basic	On Ramp	Basic	Off Ramp	Basic	On Ramp	Basic	Off Ramp	Basic	On Ramp	Basic	Off Ramp	Basic	On Ramp	Basic
1	B	C	C	C	C	C	B	C	C	C	C	C	C	C	C
Density-Based LOS by Segment															
Segment	31	32	33	34	35	36	37	38	39	40	41	42	43	44	45
Time Step	Basic	Off Ramp	Basic	On Ramp	Basic	Off Ramp	Basic	On Ramp	Basic	Off Ramp	Basic	On Ramp	Basic	Off Ramp	Basic
1	C	C	C	C	C	C	C	D	D	D	C	D	D	D	C
Density-Based LOS by Segment															
Segment	46	47													
Time Step	On Ramp	Basic													
1	D	D													
Demand-Based LOS by Segment															
Time Step	1	2	3	4	5	6	7	8	9	10	11	12	13	14	15
1	-	-	-	-	-	-	-	-	-	-	-	-	-	-	-
Demand-Based LOS by Segment															
Time Step	16	17	18	19	20	21	22	23	24	25	26	27	28	29	30
1	-	-	-	-	-	-	-	-	-	-	-	-	-	-	-
Demand-Based LOS by Segment															
Time Step	31	32	33	34	35	36	37	38	39	40	41	42	43	44	45
1	-	-	-	-	-	-	-	-	-	-	-	-	-	-	-
Demand-Based LOS by Segment															
Time Step	46	47													
1	-	-													

HCS 2010 Freeway Facilities

Project Properties table with columns for Analyst, Analysis Date, Agency, Location, User Notes, File Name, Freeway Name, Analysis Period, and PM Peak.

Facility-wide Values table with columns for Jam Density (pc/h/ln), Time Period Duration (min), Facility Length (mi), and 29.10100.

Segment Input Data

Time Period 1

Mainline Data table with columns: Seg #, From, To, Type, Length, Terrain, Adj. Demand, % Trucks, % RVs, # Lanes, FFS.

Ramp Data table with columns: Seg #, Type, Adj. Demand, % Trucks, % RVs, Lanes, Accel/Decel Length, FFS.

Weaving Segment Data table with columns: Seg #, Ramp to Ramp Prop., Adj. Demand, % Trucks, % RVs, Lanes, FFS, Off-Ramp Adj. Demand, % Trucks, % RVs, Lanes, FFS.

Time Period Independent Weaving Segment Data

Table with columns: Seg #, Configuration, Short Length, # Weaving Lanes, Min. Lane Changes Freeway: Ramp, Min. Lane Changes Ramp: Freeway, Min. Lane Changes Ramp: Ramp.

Time Period Results

Time Period 1

Large table with columns: Seg #, From, To, Type, Adj. Demand, Vol. Served, Capacity (pc/h), Capacity (veh/h), d/c Ratio, v/c ratio, Queue Length(ft), Avg. Speed (mi/h), Density (pc/mi/ln), Density (veh/mi/ln), Avg. Travel Time (min/veh), Free-Flow Travel Time (min/veh), Mainline Delay (min/veh), System Delay (min/veh), VMT Demand (veh-mi), VMT Volume (veh-mi), VHT (veh-hrs), VHD (veh-hrs).

Overall Results

Table with columns: Segment, Segment Type, Maximum d/c Ratio, Avg. Speed (mi/h), Density (pc/mi/ln), Density (veh/mi/ln), Avg. Travel Time (min/veh), Free-Flow Travel Time (min/veh), VMT Demand (veh-mi), VMT Volume (veh-mi), VHT (veh-hrs), VHD (veh-hrs).

M51	OnRamp	0.73	59.5	29.2	25.4	0.29	0.24	0.215.2	0.215.2	3.61	0.54
B52	Basic	0.73	66.6	26.2	22.0	4.02	3.82	3.378.6	3.378.6	50.75	2.49
O53	OffRamp	0.73	54.3	32.1	27.9	0.31	0.24	0.215.2	0.215.2	3.96	0.89
US 25 SPYBURN IOWA #54	Basic	0.72	66.7	25.9	22.5	0.19	0.18	0.160.2	0.160.2	2.40	0.11
M55	OnRamp	1.00	53.7	43.0	37.5	0.28	0.21	0.257.4	0.257.4	4.80	1.12
O56	OffRamp	0.67	58.2	27.4	23.0	0.25	0.21	0.257.4	0.257.4	4.42	0.74
UPWARD RD #57	Basic	0.57	69.4	19.6	16.8	0.38	0.38	0.384.3	0.384.3	5.54	0.05
M58	OnRamp	0.70	61.7	27.1	23.8	0.28	0.24	0.314.9	0.314.9	5.10	0.60
B59	Basic	0.70	67.3	25.0	22.0	2.28	2.20	2.839.5	2.839.5	42.21	1.64
O60	OffRamp	0.70	65.5	25.7	22.6	0.26	0.24	0.314.9	0.314.9	4.81	0.31
B61	Basic	0.62	69.1	21.4	18.5	0.09	0.09	0.095.4	0.095.4	1.38	0.02
US 54 - 4 SEASONS BLVD	Weaving	0.59	56.5	21.9	19.2	0.28	0.22	0.282.2	0.282.2	4.99	0.96
B63	Basic	0.64	67.2	22.7	19.7	0.09	0.09	0.103.3	0.103.3	1.54	0.06
M64	OnRamp	0.72	61.0	28.3	24.9	0.28	0.24	0.325.6	0.325.6	5.34	0.69
B65	Basic	0.72	66.7	26.1	22.9	0.16	0.15	0.200.8	0.200.8	3.01	0.14
O66	OffRamp	0.74	60.9	28.5	25.1	0.28	0.26	0.325.6	0.325.6	5.35	0.36
O67	OffRamp	0.70	54.9	30.0	26.2	0.31	0.26	0.306.6	0.306.6	5.58	0.87
BALFOUR POXY #68	Basic	0.60	63.7	22.0	18.9	0.18	0.17	0.171.1	0.171.1	2.69	0.06
M69	OnRamp	0.78	57.2	31.6	28.0	0.30	0.26	0.343.8	0.343.8	6.01	0.72
B70	Basic	0.78	62.4	29.2	25.8	1.26	1.21	1.581.3	1.581.3	25.32	0.99
O71	OffRamp	0.76	63.6	28.7	25.4	0.27	0.24	0.343.8	0.343.8	5.41	0.50
WILSON STATION NB #72	Basic	0.63	68.8	22.1	21.7	0.28	0.28	0.360.2	0.360.2	5.23	0.09
M73	OnRamp	0.76	62.4	26.3	23.2	0.27	0.24	0.343.8	0.343.8	5.51	0.60
B74	Basic	0.76	65.5	27.9	24.6	1.23	1.15	1.627.1	1.627.1	24.85	1.60
O75	OffRamp	0.78	59.8	30.5	27.0	0.29	0.26	0.343.8	0.343.8	5.75	0.46
US 25 ASHEVILLE HWY #76	Basic	0.64	64.7	23.4	20.4	0.34	0.34	0.361.1	0.361.1	5.98	0.03
M77	OnRamp	0.82	56.0	34.1	30.3	0.30	0.26	0.366.6	0.366.6	6.54	0.90
B78	Basic	0.82	60.9	31.8	28.3	1.28	1.20	1.680.3	1.680.3	27.99	1.74
O79	OffRamp	0.82	60.7	31.9	28.3	0.28	0.26	0.366.6	0.366.6	6.04	0.40
BEST AREA NB #80	Basic	0.79	62.1	29.8	26.6	0.35	0.33	0.445.7	0.445.7	7.17	0.32
M81	OnRamp	0.82	57.0	33.7	29.9	0.30	0.26	0.366.6	0.366.6	6.43	0.79
B82	Basic	0.82	60.9	31.8	28.3	1.10	1.09	0.128.3	0.128.3	2.11	0.13
O83	OffRamp	0.82	59.1	32.8	29.1	0.29	0.26	0.366.6	0.366.6	6.21	0.57
NC 260 ADNPORT RD #84	Basic	0.65	64.7	23.7	20.6	0.36	0.36	0.392.5	0.392.5	6.07	0.03
M85	OnRamp	0.88	54.7	37.5	33.5	0.31	0.26	0.395.5	0.395.5	7.23	1.15
B86	Basic	0.88	58.4	35.6	31.8	2.10	1.89	2.847.8	2.847.8	48.72	4.91
O87	OffRamp	0.88	59.4	35.0	31.2	0.29	0.26	0.395.5	0.395.5	6.65	0.57
NC 146 - LONG SHALS- #88	Basic	0.74	63.3	27.6	24.2	0.43	0.42	0.522.6	0.522.6	8.26	0.22
M89	OnRamp	0.93	53.8	40.1	35.9	0.32	0.26	0.415.0	0.415.0	7.72	1.33
B90	Basic	0.93	56.4	38.7	34.5	4.16	3.61	5.713.0	5.713.0	101.34	13.45
O91	OffRamp	0.93	55.3	39.4	35.2	0.31	0.26	0.415.0	0.415.0	7.90	1.12
NC 191 - BREVARD RD #92	Basic	0.81	61.3	31.1	27.5	0.20	0.19	0.257.9	0.257.9	4.21	0.24
M93	OnRamp	0.92	54.8	39.2	35.0	0.31	0.26	0.410.4	0.410.4	7.50	1.18
END PROJECT NB #94	Basic	0.92	56.9	37.8	33.8	0.63	0.55	0.861.9	0.861.9	15.14	1.88
Freeway			60.9	30.5	27.0	28.33	25.93	33,091.7	33,091.7	0,543.2	0,048.7

Density-Based LOS by Segment															
Segment	1	2	3	4	5	6	7	8	9	10	11	12	13	14	15
Time Step	Basic	Off Ramp	Basic	On Ramp	Basic	Off Ramp	Basic	On Ramp	Basic	Off Ramp	Basic	On Ramp	Basic	Off Ramp	Basic
1	D	D	C	D	D	D	C	E	C	C	C	C	C	C	C
Density-Based LOS by Segment															
Segment	16	17	18	19	20	21	22	23	24	25	26	27	28	29	30
Time Step	Basic	On Ramp	Basic	Off Ramp	Basic	On Ramp	Basic	Off Ramp	Basic	On Ramp	Basic	Off Ramp	Basic	On Ramp	Basic
1	C	D	D	D	D	C	D	D	C	C	C	D	D	C	D
Density-Based LOS by Segment															
Segment	31	32	33	34	35	36	37	38	39	40	41	42	43	44	45
Time Step	Basic	Off Ramp	Basic	On Ramp	Basic	Off Ramp	Basic	On Ramp	Basic	Off Ramp	Basic	On Ramp	Basic	Off Ramp	Basic
1	D	D	D	D	D	D	C	E	E	D	D	E	E	E	D
Density-Based LOS by Segment															
Segment	46	47													
Time Step	On Ramp	Basic													
1	E	E													
Demand-Based LOS by Segment															
Segment	1	2	3	4	5	6	7	8	9	10	11	12	13	14	15
1	-	-	-	-	-	-	-	-	-	-	-	-	-	-	-
Demand-Based LOS by Segment															
Segment	16	17	18	19	20	21	22	23	24	25	26	27	28	29	30
1	-	-	-	-	-	-	-	-	-	-	-	-	-	-	-
Demand-Based LOS by Segment															
Segment	31	32	33	34	35	36	37	38	39	40	41	42	43	44	45
1	-	-	-	-	-	-	-	-	-	-	-	-	-	-	-
Demand-Based LOS by Segment															
Segment	46	47													
1	-	-													

M4	OnRamp	0.95	54.3	46.6	36.3	0.31	0.26	0.427.1	0.426.1	7.85	1.29
B5	Basic	0.95	55.1	46.6	36.3	3.87	3.28	5.338.2	5.326.7	96.73	14.78
D6	OffRamp	0.95	57.8	38.7	34.6	0.29	0.26	0.427.1	0.426.1	7.37	0.81
NC 146 - LONG SHOALS- B7	Basic	0.77	62.8	28.6	25.2	0.45	0.44	0.564.5	0.561.1	8.94	0.31
M8	OnRamp	0.91	55.0	38.4	34.3	0.31	0.26	0.407.6	0.409.1	7.44	1.15
B9	Basic	0.91	56.9	37.8	33.7	2.10	1.84	2.853.2	2.863.6	50.30	6.24
D10	OffRamp	0.91	57.1	37.7	33.6	0.30	0.26	0.407.6	0.409.1	7.18	0.87
NC 280 - AIRPORT RD-B11	Basic	0.68	64.5	24.6	21.4	0.40	0.40	0.448.6	0.446.0	6.91	0.05
M12	OnRamp	0.85	55.7	35.1	31.1	0.31	0.26	0.378.7	0.379.3	6.81	0.97
B13	Basic	0.85	59.8	33.6	29.8	0.10	0.09	0.132.5	0.132.7	2.22	0.18
D14	OffRamp	0.85	59.6	33.7	29.9	0.29	0.26	0.378.7	0.379.3	6.36	0.52
AREA SB B15	Basic	0.82	61.3	31.1	27.7	0.32	0.30	0.418.8	0.416.5	6.79	0.38
M16	OnRamp	0.85	56.9	35.1	31.1	0.30	0.26	0.378.7	0.379.3	6.67	0.83
B17	Basic	0.85	59.8	33.6	29.8	1.34	1.23	1.779.9	1.782.5	29.83	2.40
D18	OffRamp	0.85	58.0	34.6	30.7	0.29	0.26	0.378.7	0.379.3	6.54	0.71
US 25 - ASHEVILLE HWY-B19	Basic	0.67	64.5	24.5	21.4	0.37	0.36	0.406.0	0.406.7	6.30	0.05
M20	OnRamp	0.80	56.9	32.3	28.6	0.30	0.26	0.355.8	0.353.9	6.22	0.78
B21	Basic	0.79	64.6	29.1	25.7	1.20	1.11	1.619.0	1.611.2	24.94	1.92
D22	OffRamp	0.79	62.1	30.3	26.8	0.27	0.24	0.355.8	0.354.0	5.70	0.65
WILSON STATION SB-B23	Basic	0.66	68.4	22.9	22.5	0.25	0.24	0.328.7	0.328.1	4.80	0.11
M24	OnRamp	0.79	60.9	30.2	26.7	0.28	0.24	0.355.8	0.354.2	5.82	0.76
B25	Basic	0.79	64.6	29.1	25.7	1.17	1.08	1.583.4	1.576.1	24.40	1.88
D26	OffRamp	0.79	63.2	29.8	26.3	0.27	0.24	0.355.8	0.354.4	5.61	0.55
D27	OffRamp	0.79	63.1	28.9	24.5	0.27	0.24	0.324.9	0.323.8	5.23	0.59
BALFOUR PROXY-B28	Basic	0.61	69.0	21.3	18.3	0.16	0.16	0.179.2	0.179.0	2.80	0.04
M29	OnRamp	0.75	61.3	28.9	25.4	0.28	0.24	0.339.0	0.340.0	5.56	0.69
B30	Basic	0.75	65.5	27.8	24.4	0.25	0.23	0.322.0	0.323.9	4.94	0.31
D31	OffRamp	0.75	62.9	29.0	25.5	0.27	0.24	0.339.0	0.340.9	5.42	0.55
B32	Basic	0.68	67.8	24.1	20.9	0.10	0.10	0.121.5	0.121.0	1.78	0.06
US 84 - 4 SEASONS BL-W33	Weaving	0.67	52.6	28.9	25.4	0.30	0.23	0.323.0	0.322.2	6.13	1.52
B34	Basic	0.68	65.3	25.0	21.7	0.04	0.04	0.045.3	0.045.4	0.69	0.05
M35	OnRamp	0.73	61.4	28.3	24.8	0.28	0.24	0.328.3	0.328.1	5.35	0.66
B36	Basic	0.73	66.4	26.5	23.2	2.29	2.18	2.932.5	2.931.3	44.14	2.27
D37	OffRamp	0.73	62.1	28.3	24.8	0.27	0.24	0.328.3	0.328.1	5.29	0.60
UPWARD RD-B38	Basic	0.60	69.4	20.6	17.6	0.38	0.37	0.400.6	0.398.6	5.74	0.05
M39	OnRamp	0.78	24.5	37.1	49.8	0.66	0.23	0.294.8	0.283.4	11.56	7.53
D40	OffRamp	1.04	56.3	42.6	37.2	0.29	0.23	0.264.8	0.263.4	5.92	0.97
US 25 - STYER RD-B41	Basic	0.77	66.3	26.6	23.1	0.47	0.44	0.413.3	0.394.8	5.95	0.31
M42	OnRamp	0.77	60.6	29.0	25.2	0.28	0.24	0.229.0	0.217.3	3.99	0.48
B43	Basic	0.77	66.3	26.6	23.1	3.70	3.51	3.302.1	3.133.2	47.23	2.47
D44	OffRamp	0.77	59.4	28.7	25.8	0.29	0.24	0.229.0	0.217.3	3.66	0.56
HOLBERT COVE RD- B45	Basic	0.73	67.1	25.3	21.9	0.44	0.42	0.374.9	0.361.9	5.39	0.22
M46	OnRamp	0.78	59.2	30.1	26.1	0.29	0.24	0.230.7	0.221.6	3.74	0.58
END PROJECT SB-B47	Basic	0.78	65.9	27.2	23.7	0.91	0.86	0.812.0	0.780.0	11.84	0.70
Freeway			59.8	32.0	28.3	28.73	25.65	34,204.5	33,888.2	0,567.0	0,063.8

Density-Based LOS by Segment															
Segment	1	2	3	4	5	6	7	8	9	10	11	12	13	14	15
Time Step	Basic	Off Ramp	Basic	On Ramp	Basic	Off Ramp	Basic	On Ramp	Basic	Off Ramp	Basic	On Ramp	Basic	Off Ramp	Basic
1	E	E	D	E	E	E	D	E	E	E	C	E	D	D	D
Density-Based LOS by Segment															
Segment	16	17	18	19	20	21	22	23	24	25	26	27	28	29	30
Time Step	On Ramp	Basic	Off Ramp	Basic	On Ramp	Basic	Off Ramp	Basic	On Ramp	Basic	Off Ramp	Off Ramp	Basic	On Ramp	Basic
1	E	D	D	C	D	D	D	C	D	D	D	C	C	D	D
Density-Based LOS by Segment															
Segment	31	32	33	34	35	36	37	38	39	40	41	42	43	44	45
Time Step	Off Ramp	Basic	Weaving	Basic	On Ramp	Basic	Off Ramp	Basic	On Ramp	Basic	On Ramp	Basic	Off Ramp	Basic	Off Ramp
1	D	C	D	C	D	D	D	C	F	E	D	D	D	D	C
Density-Based LOS by Segment															
Segment	46	47													
Time Step	On Ramp	Basic													
1	D	D													
Demand-Based LOS by Segment															
Time Step	1	2	3	4	5	6	7	8	9	10	11	12	13	14	15
1	-	-	-	-	-	-	-	-	-	-	-	-	-	-	-
Demand-Based LOS by Segment															
Time Step	16	17	18	19	20	21	22	23	24	25	26	27	28	29	30
1	-	-	-	-	-	-	-	-	-	-	-	-	-	-	-
Demand-Based LOS by Segment															
Time Step	31	32	33	34	35	36	37	38	39	40	41	42	43	44	45
1	-	-	-	-	-	-	-	-	-	-	F	-	-	-	-
Demand-Based LOS by Segment															
Time Step	46	47													
1	-	-													

M4	OnRamp	0.78	57.0	22.1	28.8	0.30	0.26	0.351.7	0.351.7	6.17	0.76
B5	Basic	0.78	62.3	29.6	26.5	3.42	3.28	4.396.3	4.396.3	70.61	2.98
D6	OffRamp	0.78	59.6	30.9	27.7	0.29	0.26	0.351.7	0.351.7	5.90	0.49
NC 146 - SHEALS- B7	Basic	0.61	64.8	22.0	19.4	0.44	0.44	0.446.0	0.446.0	6.88	0.02
M8	OnRamp	0.73	57.7	29.6	26.4	0.30	0.26	0.327.3	0.327.3	5.68	0.64
B9	Basic	0.73	63.5	27.1	24.2	1.88	1.84	2.290.9	2.290.9	36.05	0.81
D10	OffRamp	0.73	58.8	29.3	26.1	0.29	0.26	0.327.3	0.327.3	5.57	0.54
NC 280 - AIRPORT RD-B11	Basic	0.52	64.7	19.0	16.5	0.40	0.40	0.344.7	0.344.7	5.33	0.02
M12	OnRamp	0.68	57.8	27.3	24.3	0.29	0.26	0.302.3	0.302.3	5.23	0.58
B13	Basic	0.68	63.6	25.1	22.3	0.09	0.09	0.105.8	0.105.8	1.66	0.04
D14	OffRamp	0.68	60.5	26.4	23.4	0.28	0.26	0.302.3	0.302.3	5.00	0.35
AREA SB B15	Basic	0.64	64.7	23.4	20.9	0.30	0.30	0.331.0	0.331.0	5.12	0.03
M16	OnRamp	0.68	58.8	26.8	23.8	0.29	0.26	0.302.3	0.302.3	5.14	0.49
B17	Basic	0.68	64.4	24.8	22.0	1.24	1.23	1.420.7	1.420.7	22.04	0.19
D18	OffRamp	0.68	59.6	26.8	23.8	0.29	0.26	0.302.3	0.302.3	5.08	0.43
US 25 - ASHEVILLE HWY-B19	Basic	0.53	64.7	19.1	16.7	0.36	0.36	0.317.8	0.317.8	4.91	0.02
M20	OnRamp	0.64	58.5	25.4	22.5	0.29	0.26	0.283.3	0.283.3	4.84	0.49
B21	Basic	0.63	68.9	21.8	19.3	1.13	1.11	1.289.1	1.289.1	18.70	0.28
D22	OffRamp	0.63	64.0	23.5	20.8	0.27	0.24	0.283.3	0.283.3	4.43	0.38
WILSON STATION SB-B23	Basic	0.52	69.5	18.0	17.7	0.25	0.24	0.262.0	0.262.0	3.77	0.03
M24	OnRamp	0.63	63.4	21.3	18.8	0.27	0.24	0.283.3	0.283.3	4.47	0.42
B25	Basic	0.63	68.9	21.8	19.3	1.10	1.08	1.260.7	1.260.7	18.29	0.28
D26	OffRamp	0.63	64.9	23.2	20.5	0.26	0.24	0.283.3	0.283.3	4.36	0.32
D27	OffRamp	0.58	57.2	24.3	21.3	0.30	0.24	0.259.9	0.259.9	4.54	0.61
BALFOUR PROXY-B28	Basic	0.46	68.3	16.2	13.8	0.17	0.16	0.134.0	0.134.0	1.96	0.05
M29	OnRamp	0.59	63.1	22.5	19.8	0.27	0.24	0.267.8	0.267.8	4.25	0.42
B30	Basic	0.59	69.4	20.6	18.1	0.23	0.23	0.254.4	0.254.4	3.67	0.03
D31	OffRamp	0.59	65.8	21.7	19.1	0.26	0.24	0.267.8	0.267.8	4.07	0.24
B32	Basic	0.54	69.2	18.7	16.3	0.10	0.10	0.095.9	0.095.9	1.39	0.02
US 84 - 4 SEASONS BL-W33	Weaving	0.53	55.1	19.8	17.4	0.29	0.23	0.254.9	0.254.9	4.62	0.98
B34	Basic	0.52	66.0	18.8	16.3	0.04	0.04	0.034.3	0.034.3	0.52	0.03
M35	OnRamp	0.57	62.8	21.7	19.0	0.27	0.24	0.254.8	0.254.8	4.06	0.42
B36	Basic	0.57	69.7	19.6	17.2	2.19	2.18	2.275.8	2.275.8	32.66	0.15
D37	OffRamp	0.57	63.8	21.4	18.7	0.27	0.24	0.254.8	0.254.8	3.99	0.35
UPWARD RD-B38	Basic	0.46	69.7	15.8	13.5	0.37	0.37	0.306.3	0.306.3	4.39	0.02
M39	OnRamp	0.55	62.1	21.3	18.6	0.26	0.23	0.224.7	0.224.7	3.78	0.41
D40	OffRamp	0.53	60.8	20.8	18.6	0.27	0.23	0.234.7	0.234.7	3.86	0.51
US 25 - STYER RD-B41	Basic	0.61	69.3	21.0	18.3	0.45	0.44	0.326.4	0.326.4	4.71	0.05
M42	OnRamp	0.61	62.2	23.5	20.5	0.27	0.24	0.181.3	0.181.3	2.91	0.32
B43	Basic	0.61	69.2	21.2	18.5	3.55	3.51	2.614.0	2.614.0	37.79	0.44
D44	OffRamp	0.61	61.1	24.0	20.9	0.28	0.24	0.181.3	0.181.3	2.87	0.38
HOLBERT COVE RD- B45	Basic	0.57	69.7	19.6	16.9	0.42	0.42	0.290.3	0.290.3	4.17	0.02
M46	OnRamp	0.60	61.1	23.5	20.5	0.28	0.24	0.178.2	0.178.2	2.92	0.37
END PROJECT SB-B47	Basic	0.60	69.3	20.8	18.1	0.87	0.86	0.627.3	0.627.3	9.05	0.09
Freeway		64.4	23.9	21.2	26.74	25.65	27.286.7	27.286.7	0.423.5	0.018.2	

Density-Based LOS by Segment															
Segment	1	2	3	4	5	6	7	8	9	10	11	12	13	14	15
Time Step	Basic	Off Ramp	Basic	On Ramp	Basic	Off Ramp	Basic	On Ramp	Basic	Off Ramp	Basic	On Ramp	Basic	Off Ramp	Basic
1	D	D	C	D	D	D	C	D	D	D	C	C	C	C	C
Density-Based LOS by Segment															
Segment	16	17	18	19	20	21	22	23	24	25	26	27	28	29	30
Time Step	On Ramp	Basic	Off Ramp	Basic	On Ramp	Basic	Off Ramp	Basic	On Ramp	Basic	Off Ramp	Off Ramp	Basic	On Ramp	Basic
1	C	C	C	C	C	C	C	C	B	C	C	C	C	B	C
Density-Based LOS by Segment															
Segment	31	32	33	34	35	36	37	38	39	40	41	42	43	44	45
Time Step	Off Ramp	Basic	Weaving	Basic	On Ramp	Basic	Off Ramp	Basic	On Ramp	Basic	Off Ramp	Basic	On Ramp	Basic	Off Ramp
1	C	C	B	C	C	C	C	B	C	C	D	C	C	C	C
Density-Based LOS by Segment															
Segment	46	47													
Time Step	On Ramp	Basic													
1	C	C													
Demand-Based LOS by Segment															
Time Step	1	2	3	4	5	6	7	8	9	10	11	12	13	14	15
1	-	-	-	-	-	-	-	-	-	-	-	-	-	-	-
Demand-Based LOS by Segment															
Time Step	16	17	18	19	20	21	22	23	24	25	26	27	28	29	30
1	-	-	-	-	-	-	-	-	-	-	-	-	-	-	-
Demand-Based LOS by Segment															
Time Step	31	32	33	34	35	36	37	38	39	40	41	42	43	44	45
1	-	-	-	-	-	-	-	-	-	-	-	-	-	-	-
Demand-Based LOS by Segment															
Time Step	46	47													
1	-	-													

2040 Build 8 Lane

HCS 2010 Freeway Facilities

Project Properties

Table with Project Properties including Analyst, Analysis Date, Agency, Location, User Notes, and File Name.

Facility-wide Values

Table with Facility-wide Values including Jam Density, Time Period Duration, Facility Length, and Average Density.

Segment Input Data

Time Period 1

Mainline Data table listing segments with columns for Seg #, From, To, Type, Length, Terrain, Adj. Demand, % Trucks, % RVs, # Lanes, and FFS.

Ramp Data table listing segments with columns for Seg #, Type, Adj. Demand, % Trucks, % RVs, Lanes, Accel/Decel Length, and FFS.

Weaving Segment Data table listing segments with columns for Seg #, Ramp to Ramp Prop., Adj. Demand, % Trucks, % RVs, Lanes, FFS, and other weaving metrics.

Time Period Independent Weaving Segment Data

Table with Weaving Segment Data including Seg #, Configuration, Short Length, # Weaving Lanes, and various ramp change metrics.

Time Period Results

Time Period 1

Large table with Time Period Results including columns for Seg #, From, To, Type, Adj. Demand, Vol. Served, Capacity, d/c Ratio, v/c ratio, Queue Length, Avg. Speed, Density, Avg. Travel Time, Free-Flow Travel Time, Mainline Delay, System Delay, VMT Demand, VMT Volume, VHT, and VHD.

Overall Results

Summary table with Overall Results including Segment, Segment Type, Maximum d/c Ratio, Avg. Speed, Density, Avg. Travel Time, Free-Flow Travel Time, VMT Demand, VMT Volume, VHT, and VHD.

M51	OnRamp	0.60	61.1	23.6	20.6	0.20	0.24	0.178.9	0.178.9	2.93	0.37
B52	Basic	0.60	69.3	20.9	18.2	3.86	3.82	2,808.8	2,808.8	40.53	0.41
O53	OffRamp	0.60	54.3	26.6	23.2	0.31	0.24	0.178.9	0.178.9	3.29	0.74
US 25 SPYGLASS I-85 NB	Basic	0.60	68.1	21.0	18.3	0.19	0.18	0.133.0	0.133.0	1.95	0.05
M55	OnRamp	0.83	59.6	32.1	28.0	0.25	0.21	0.214.0	0.214.0	3.99	0.53
O56	OffRamp	0.43	66.9	14.9	13.0	0.22	0.21	0.214.0	0.214.0	3.20	0.14
UPWARD RD NB	Basic	0.35	69.8	11.9	10.2	0.38	0.38	0.312.8	0.312.8	4.48	0.01
M58	OnRamp	0.44	64.9	16.0	14.0	0.26	0.24	0.260.9	0.260.9	4.02	0.29
B59	Basic	0.44	70.0	14.9	13.1	2.20	2.20	2,352.1	2,352.1	33.60	0.00
O60	OffRamp	0.44	68.7	15.2	13.4	0.25	0.24	0.260.9	0.260.9	3.80	0.07
B61	Basic	0.38	69.7	13.2	11.5	0.09	0.09	0.079.5	0.079.5	1.14	0.00
US 54 + 4 SEASONS BLVD	Weaving	0.39	59.4	13.9	12.2	0.26	0.22	0.235.4	0.235.4	3.96	0.60
B63	Basic	0.39	67.8	13.9	12.1	0.09	0.09	0.085.1	0.085.1	1.26	0.04
M64	OnRamp	0.47	64.1	17.5	15.5	0.27	0.24	0.283.4	0.283.4	4.42	0.37
B65	Basic	0.47	69.2	16.3	14.4	0.15	0.15	0.174.8	0.174.8	2.53	0.03
O66	OffRamp	0.47	68.3	16.5	14.6	0.25	0.24	0.283.4	0.283.4	4.15	0.10
O67	OffRamp	0.45	61.5	17.5	15.4	0.28	0.24	0.269.2	0.269.2	4.38	0.53
BALFOUR POKY NB	Basic	0.37	68.9	12.8	11.0	0.16	0.16	0.144.1	0.144.1	2.09	0.03
M69	OnRamp	0.50	64.5	18.4	16.4	0.26	0.24	0.303.1	0.303.1	4.70	0.37
B70	Basic	0.50	70.0	17.1	15.2	1.12	1.12	1,394.0	1,394.0	19.92	0.00
O71	OffRamp	0.50	66.6	18.0	16.0	0.26	0.24	0.303.1	0.303.1	4.55	0.22
WILSON STATION NB 872	Basic	0.42	69.7	14.5	14.2	0.28	0.28	0.319.2	0.319.2	4.58	0.02
M73	OnRamp	0.50	65.3	16.6	14.8	0.26	0.24	0.303.1	0.303.1	4.64	0.31
B74	Basic	0.50	70.0	17.1	15.2	1.15	1.15	1,434.5	1,434.5	20.49	0.00
O75	OffRamp	0.51	62.4	19.2	17.1	0.27	0.26	0.303.1	0.303.1	4.85	0.19
US 25 ASHEVILLE HWY 425	Basic	0.43	64.8	15.4	13.6	0.34	0.34	0.320.9	0.320.9	4.95	0.01
M77	OnRamp	0.54	59.7	21.1	18.9	0.29	0.26	0.324.8	0.324.8	5.44	0.44
B78	Basic	0.54	65.0	19.7	17.6	1.20	1.20	1,488.6	1,488.6	22.90	0.00
O79	OffRamp	0.54	63.5	20.1	18.0	0.27	0.26	0.324.8	0.324.8	5.11	0.11
BEST AREA NB 880	Basic	0.51	64.9	18.6	16.8	0.33	0.33	0.391.5	0.391.5	6.03	0.01
M81	OnRamp	0.54	60.4	20.9	18.7	0.28	0.26	0.324.8	0.324.8	5.38	0.38
B82	Basic	0.54	64.1	20.0	17.8	0.09	0.09	0.113.7	0.113.7	1.77	0.02
O83	OffRamp	0.54	61.6	20.8	18.6	0.28	0.26	0.324.8	0.324.8	5.27	0.28
NC 280 AIRPORT RD NB	Basic	0.43	64.8	15.5	13.6	0.36	0.36	0.345.3	0.345.3	5.33	0.02
M85	OnRamp	0.59	59.9	22.8	20.5	0.28	0.26	0.353.5	0.353.5	5.91	0.47
B86	Basic	0.59	65.0	21.3	19.1	1.89	1.89	2,545.1	2,545.1	39.15	0.00
O87	OffRamp	0.59	62.1	22.3	20.0	0.27	0.26	0.353.5	0.353.5	5.69	0.26
NC 146 + LONG SHALLS RD	Basic	0.40	64.9	17.9	15.8	0.42	0.42	0.467.3	0.467.3	7.20	0.01
M89	OnRamp	0.63	58.8	24.9	22.5	0.29	0.26	0.379.2	0.379.2	6.45	0.61
B90	Basic	0.63	64.9	22.8	20.6	3.62	3.61	5,220.2	5,220.2	80.43	0.12
O91	OffRamp	0.63	58.3	25.4	22.9	0.29	0.26	0.379.2	0.379.2	6.50	0.67
NC 191 + BREWARD RD NB	Basic	0.55	64.2	20.0	17.9	0.19	0.19	0.233.3	0.233.3	3.64	0.05
M93	OnRamp	0.61	59.2	24.1	21.7	0.29	0.26	0.365.6	0.365.6	6.17	0.55
END PROJECT NB 894	Basic	0.61	64.9	22.1	19.8	0.55	0.55	0.767.8	0.767.8	11.84	0.02
Freeway			65.7	19.3	17.2	26.40	25.77	28,900.5	28,900.5	0,439.6	0,009.9

Density-Based LOS by Segment															
Segment	1	2	3	4	5	6	7	8	9	10	11	12	13	14	15
Time Step	Basic	Off Ramp	Basic	On Ramp	Basic	Off Ramp	Basic	On Ramp	Basic	Off Ramp	Basic	On Ramp	Basic	Off Ramp	Basic
1	C	C	C	C	C	C	C	D	B	B	B	B	B	B	B
Density-Based LOS by Segment															
Segment	16	17	18	19	20	21	22	23	24	25	26	27	28	29	30
Time Step	Basic	On Ramp	Basic	Off Ramp	Off Ramp	Basic	On Ramp	Basic	Off Ramp	Basic	On Ramp	Basic	Off Ramp	Basic	On Ramp
1	B	B	B	B	B	B	B	B	B	B	B	B	B	B	B
Density-Based LOS by Segment															
Segment	31	32	33	34	35	36	37	38	39	40	41	42	43	44	45
Time Step	Basic	Off Ramp	Basic	On Ramp	Basic	Off Ramp	Basic	On Ramp	Basic	Off Ramp	Basic	On Ramp	Basic	Off Ramp	Basic
1	C	C	C	C	C	C	C	B	C	C	C	B	C	C	C
Density-Based LOS by Segment															
Segment	46	47													
Time Step	On Ramp	Basic													
1	C	C													
Demand-Based LOS by Segment															
Segment	1	2	3	4	5	6	7	8	9	10	11	12	13	14	15
1	-	-	-	-	-	-	-	-	-	-	-	-	-	-	-
Demand-Based LOS by Segment															
Segment	16	17	18	19	20	21	22	23	24	25	26	27	28	29	30
1	-	-	-	-	-	-	-	-	-	-	-	-	-	-	-
Demand-Based LOS by Segment															
Segment	31	32	33	34	35	36	37	38	39	40	41	42	43	44	45
1	-	-	-	-	-	-	-	-	-	-	-	-	-	-	-
Demand-Based LOS by Segment															
Segment	46	47													
1	-	-													

#51	OnRamp	0.73	59.5	29.4	25.5	0.29	0.24	0.215.9	0.217.3	3.65	0.55
#52	Basic	0.73	66.3	26.5	23.1	4.03	3.82	3.898.8	3.412.1	51.43	2.68
#53	OffRamp	0.73	59.8	29.5	25.6	0.29	0.24	0.215.9	0.217.3	3.64	0.53
US 25 SPYRITH IOWA #54	Basic	0.72	66.8	25.9	22.5	0.19	0.18	0.160.7	0.159.8	2.39	0.11
#55	OnRamp	1.01	53.6	43.1	37.5	0.28	0.21	0.259.4	0.258.5	4.82	1.13
#56	OffRamp	0.50	65.7	18.3	16.0	0.23	0.21	0.259.4	0.258.5	3.94	0.24
UPWARD RD #57	Basic	0.43	69.8	14.8	12.7	0.38	0.38	0.391.6	0.389.7	5.59	0.02
#58	OnRamp	0.54	64.3	19.6	17.2	0.27	0.24	0.324.5	0.323.9	5.04	0.41
#59	Basic	0.54	69.9	18.6	16.3	2.20	2.20	2.925.9	2.920.2	41.78	0.06
#60	OffRamp	0.54	65.8	19.7	17.3	0.26	0.24	0.324.5	0.323.9	4.92	0.30
#61	Basic	0.48	69.2	16.5	14.3	0.09	0.09	0.098.5	0.098.4	1.42	0.02
US 54 + 4 SEASONS BLVD #62	Weaving	0.48	57.0	20.1	17.6	0.27	0.22	0.292.3	0.289.1	5.07	0.94
#63	Basic	0.50	67.3	17.7	15.4	0.09	0.09	0.107.9	0.107.8	1.60	0.06
#64	OnRamp	0.57	63.6	21.2	18.8	0.27	0.24	0.344.6	0.345.2	5.43	0.50
#65	Basic	0.57	69.1	19.9	17.6	0.15	0.15	0.212.5	0.212.9	3.08	0.04
#66	OnRamp	0.57	66.7	20.6	18.2	0.26	0.24	0.344.6	0.345.2	5.18	0.25
#67	OffRamp	0.54	65.4	19.8	17.4	0.26	0.24	0.325.6	0.323.9	4.95	0.33
BAL FOUR POXY #68	Basic	0.47	69.4	16.0	13.8	0.16	0.16	0.182.8	0.181.8	2.62	0.02
#69	OnRamp	0.60	63.8	22.1	19.6	0.27	0.24	0.366.6	0.366.5	5.75	0.51
#70	Basic	0.60	69.3	21.0	18.6	1.13	1.12	1.686.4	1.685.8	24.34	0.25
#71	OffRamp	0.60	64.7	22.4	19.9	0.26	0.24	0.366.6	0.366.5	5.66	0.42
WILSON STATION NB #72	Basic	0.51	69.6	17.6	17.2	0.28	0.28	0.385.5	0.386.4	5.55	0.03
#73	OnRamp	0.60	64.3	22.1	19.7	0.27	0.24	0.366.6	0.366.5	5.70	0.47
#74	Basic	0.60	69.3	21.0	18.6	1.16	1.15	1.735.3	1.734.7	25.04	0.26
#75	OffRamp	0.62	61.0	23.8	21.2	0.28	0.26	0.366.6	0.366.5	6.01	0.37
US 25 ASHEVILLE HWY #76	Basic	0.52	64.7	18.7	16.4	0.34	0.34	0.390.3	0.388.3	6.00	0.02
#77	OnRamp	0.66	58.9	25.6	22.8	0.29	0.26	0.390.9	0.392.0	6.66	0.63
#78	Basic	0.66	64.7	23.9	21.3	1.21	1.20	1.791.7	1.796.9	27.78	0.13
#79	OffRamp	0.66	62.2	24.9	22.2	0.27	0.26	0.390.9	0.392.0	6.30	0.27
BIEST AREA NB #80	Basic	0.63	64.8	22.7	20.4	0.33	0.33	0.475.3	0.475.0	7.33	0.02
#81	OnRamp	0.66	59.5	25.8	23.1	0.29	0.26	0.390.9	0.392.0	6.59	0.55
#82	Basic	0.66	63.9	24.2	21.6	0.09	0.09	0.136.8	0.137.2	2.15	0.04
#83	OffRamp	0.66	60.2	25.7	22.9	0.28	0.26	0.390.9	0.392.0	6.51	0.48
NC 269 ADNPORT RD #84	Basic	0.53	64.7	19.0	16.7	0.36	0.36	0.426.1	0.424.4	6.56	0.03
#85	OnRamp	0.71	58.8	27.3	24.5	0.29	0.26	0.423.9	0.421.9	7.18	0.69
#86	Basic	0.71	64.1	25.8	23.2	1.02	1.89	3.052.3	3.037.5	47.41	0.68
#87	OffRamp	0.71	60.6	27.3	24.5	0.28	0.26	0.423.9	0.421.9	6.96	0.47
NC 146 - LONG SIGNAL #88	Basic	0.60	64.8	21.7	19.2	0.42	0.42	0.565.1	0.565.9	8.73	0.03
#89	OnRamp	0.74	57.9	29.4	26.4	0.29	0.26	0.444.9	0.443.2	7.66	0.84
#90	Basic	0.74	63.4	27.4	24.6	3.70	3.61	6.124.6	6.101.1	96.27	2.40
#91	OnRamp	0.74	60.8	28.6	25.6	0.28	0.26	0.444.9	0.443.2	7.28	0.67
NC 191 - BREWARD RD #92	Basic	0.65	64.5	23.8	21.2	0.19	0.19	0.276.7	0.277.9	4.31	0.03
#93	OnRamp	0.73	58.4	28.9	25.9	0.29	0.26	0.435.0	0.434.7	7.45	0.76
END PROJECT NB #94	Basic	0.73	63.7	26.8	24.0	0.56	0.55	0.913.5	0.912.8	14.33	0.29
Freeway			64.7	23.7	21.0	26.88	25.77	34,834.1	34,804.1	0,537.9	0,020.6

Density-Based LOS by Segment															
Segment	1	2	3	4	5	6	7	8	9	10	11	12	13	14	15
Time Step	Basic	Off Ramp	Basic	On Ramp	Basic	Off Ramp	Basic	On Ramp	Basic	Off Ramp	Basic	On Ramp	Basic	Off Ramp	Basic
1	D	D	C	D	D	D	C	E	B	B	B	C	C	B	C
Density-Based LOS by Segment															
Segment	16	17	18	19	20	21	22	23	24	25	26	27	28	29	30
Time Step	Basic	On Ramp	Basic	Off Ramp	Off Ramp	Basic	On Ramp	Basic	Off Ramp	Basic	On Ramp	Basic	Off Ramp	Basic	On Ramp
1	B	C	C	C	B	B	C	C	C	B	C	C	C	C	C
Density-Based LOS by Segment															
Segment	31	32	33	34	35	36	37	38	39	40	41	42	43	44	45
Time Step	Basic	Off Ramp	Basic	On Ramp	Basic	Off Ramp	Basic	On Ramp	Basic	Off Ramp	Basic	On Ramp	Basic	Off Ramp	Basic
1	C	C	C	C	C	C	C	C	C	C	C	D	D	D	C
Density-Based LOS by Segment															
Segment	46	47													
Time Step	On Ramp	Basic													
1	D	D													
Demand-Based LOS by Segment															
Segment	1	2	3	4	5	6	7	8	9	10	11	12	13	14	15
1	-	-	-	-	-	-	-	-	F	-	-	-	-	-	-
Demand-Based LOS by Segment															
Segment	16	17	18	19	20	21	22	23	24	25	26	27	28	29	30
1	-	-	-	-	-	-	-	-	-	-	-	-	-	-	-
Demand-Based LOS by Segment															
Segment	31	32	33	34	35	36	37	38	39	40	41	42	43	44	45
1	-	-	-	-	-	-	-	-	-	-	-	-	-	-	-
Demand-Based LOS by Segment															
Segment	46	47													
1	-	-													

M4	OnRamp	0.77	56.6	31.5	28.2	0.30	0.26	0.465.4	0.460.2	8.14	1.05
B5	Basic	0.77	62.7	28.8	25.0	3.40	3.28	5,754.6	5,752.8	91.80	3.30
D6	OffRamp	0.77	60.9	29.6	26.6	0.28	0.26	0.460.4	0.460.2	7.55	0.47
NC 146 - SHEALS- B7	Basic	0.63	64.8	22.8	20.1	0.44	0.44	0.614.5	0.617.9	9.53	0.02
M8	OnRamp	0.74	58.5	29.0	26.0	0.29	0.26	0.439.4	0.438.9	7.51	0.75
B9	Basic	0.74	63.5	27.2	24.3	1.88	1.84	3,075.9	3,072.4	48.40	1.13
D10	OffRamp	0.74	59.0	29.3	26.2	0.27	0.26	0.439.4	0.438.9	7.44	0.68
NC 280 - AIRPORT RD-B11	Basic	0.55	64.7	20.2	17.6	0.40	0.40	0.490.7	0.491.2	7.59	0.03
M12	OnRamp	0.68	58.6	26.7	23.7	0.29	0.26	0.406.4	0.404.8	6.90	0.67
B13	Basic	0.68	63.8	25.1	22.3	0.09	0.09	0.142.2	0.141.7	2.22	0.04
D14	OffRamp	0.68	62.2	25.8	22.9	0.27	0.26	0.406.4	0.404.8	6.51	0.29
AREA SB B15	Basic	0.66	64.7	23.9	21.3	0.30	0.30	0.449.7	0.450.9	6.97	0.03
M16	OnRamp	0.68	59.4	26.8	23.9	0.29	0.26	0.406.4	0.404.8	6.82	0.59
B17	Basic	0.68	64.4	24.9	22.1	1.24	1.23	1,910.0	1,902.7	29.53	0.26
D18	OffRamp	0.68	60.0	26.7	23.7	0.28	0.26	0.406.4	0.404.8	6.74	0.52
US 25 - ASHEVILLE HWY-B19	Basic	0.55	64.7	19.8	17.4	0.36	0.36	0.442.1	0.442.1	6.83	0.03
M20	OnRamp	0.65	59.2	25.2	22.4	0.29	0.26	0.382.1	0.383.5	6.48	0.58
B21	Basic	0.63	68.8	22.1	19.6	1.13	1.11	1,738.6	1,745.0	25.37	0.44
D22	OffRamp	0.63	64.5	23.6	20.9	0.26	0.24	0.382.1	0.383.5	5.94	0.46
WILSON STATION SB-B23	Basic	0.53	69.5	18.2	17.9	0.25	0.24	0.353.8	0.353.7	5.09	0.04
M24	OnRamp	0.63	63.8	23.4	20.7	0.27	0.24	0.382.1	0.383.5	6.01	0.54
B25	Basic	0.63	68.8	22.1	19.6	1.10	1.08	1,706.4	1,706.7	24.81	0.43
D26	OffRamp	0.63	65.8	23.1	20.5	0.26	0.24	0.382.1	0.383.5	5.82	0.35
D27	OffRamp	0.58	69.4	21.1	18.6	0.26	0.24	0.346.7	0.346.3	5.38	0.25
BALFOUR PROXY-B28	Basic	0.50	69.4	17.5	15.1	0.16	0.16	0.107.8	0.106.9	2.87	0.02
M29	OnRamp	0.61	64.0	22.3	19.7	0.27	0.24	0.367.2	0.366.5	5.73	0.69
B30	Basic	0.61	69.2	21.1	18.6	0.23	0.23	0.348.8	0.348.2	5.03	0.06
D31	OffRamp	0.61	65.8	22.2	19.6	0.26	0.24	0.367.2	0.366.5	5.57	0.33
B32	Basic	0.55	69.2	19.1	16.7	0.10	0.10	0.131.9	0.131.3	1.90	0.02
US 84 - 4 SEASONS BL-W33	Weaving	0.57	52.8	24.5	21.7	0.30	0.23	0.348.0	0.347.7	6.98	1.62
B34	Basic	0.54	65.4	20.0	17.4	0.04	0.04	0.048.4	0.048.6	0.74	0.05
M35	OnRamp	0.58	63.9	21.5	18.9	0.27	0.24	0.347.1	0.345.2	5.40	0.47
B36	Basic	0.58	69.6	19.9	17.5	2.19	2.18	3,100.7	3,083.5	44.30	0.24
D37	OffRamp	0.58	64.4	21.5	18.9	0.26	0.24	0.347.1	0.345.2	5.36	0.43
UPWARD RD-B38	Basic	0.47	69.7	16.3	14.0	0.37	0.37	0.422.0	0.424.7	6.69	0.02
M39	OnRamp	0.54	17.3	60.6	52.8	0.93	0.23	0.305.8	0.283.4	16.35	12.31
D40	OffRamp	1.08	56.4	42.7	37.3	0.20	0.23	0.305.8	0.283.4	5.02	0.97
US 25 - STYER RD-B41	Basic	0.80	66.4	26.5	23.1	0.47	0.44	0.431.3	0.394.8	5.95	0.31
M42	OnRamp	0.81	60.4	29.7	25.8	0.28	0.24	0.239.0	0.221.6	3.67	0.51
B43	Basic	0.81	65.9	27.2	23.7	3.73	3.51	3,445.5	3,194.6	48.48	2.84
D44	OffRamp	0.81	59.4	30.2	26.3	0.29	0.24	0.239.0	0.221.6	3.73	0.57
HOLBERT COVE RD- B45	Basic	0.77	67.1	25.3	21.9	0.44	0.42	0.392.1	0.361.9	5.39	0.22
M46	OnRamp	0.81	59.2	30.0	26.1	0.29	0.24	0.240.6	0.221.6	3.74	0.58
END PROJECT SB-B47	Basic	0.81	65.9	27.2	23.7	0.91	0.86	0.847.0	0.780.0	11.83	0.69
Freeway			63.0	25.3	22.4	27.59	25.65	36,538.3	36,040.3	0,572.4	0,037.0

Density-Based LOS by Segment															
Segment	1	2	3	4	5	6	7	8	9	10	11	12	13	14	15
Time Step	Basic	Off Ramp	Basic	On Ramp	Basic	Off Ramp	Basic	On Ramp	Basic	Off Ramp	Basic	On Ramp	Basic	Off Ramp	Basic
1	D	D	C	D	D	D	C	D	D	D	C	C	C	C	C
Density-Based LOS by Segment															
Segment	16	17	18	19	20	21	22	23	24	25	26	27	28	29	30
Time Step	On Ramp	Basic	Off Ramp	Basic	On Ramp	Basic	Off Ramp	Basic	On Ramp	Basic	Off Ramp	Off Ramp	Basic	On Ramp	Basic
1	C	C	C	C	C	C	C	C	C	C	C	C	C	B	C
Density-Based LOS by Segment															
Segment	31	32	33	34	35	36	37	38	39	40	41	42	43	44	45
Time Step	Off Ramp	Basic	Weaving	Basic	On Ramp	Basic	Off Ramp	Basic	On Ramp	Basic	Off Ramp	Basic	On Ramp	Basic	Off Ramp
1	C	C	C	C	C	C	C	C	B	F	E	D	D	D	C
Density-Based LOS by Segment															
Segment	46	47													
Time Step	On Ramp	Basic													
1	D	D													
Demand-Based LOS by Segment															
Segment	1	2	3	4	5	6	7	8	9	10	11	12	13	14	15
1	-	-	-	-	-	-	-	-	-	-	-	-	-	-	-
Demand-Based LOS by Segment															
Segment	16	17	18	19	20	21	22	23	24	25	26	27	28	29	30
1	-	-	-	-	-	-	-	-	-	-	-	-	-	-	-
Demand-Based LOS by Segment															
Segment	31	32	33	34	35	36	37	38	39	40	41	42	43	44	45
1	-	-	-	-	-	-	-	-	-	-	F	-	-	-	-
Demand-Based LOS by Segment															
Segment	46	47													
1	-	-													

HCS 2010 Freeway Facilities

Project Properties table with columns: Analyst, Analysis Date, Agency, Location, User Notes, File Name, Freeway Name, Analysis Period, PM Peak, From, To, Exit 33 (NC 191), Exit 59 (Hobert Cove Rd), Analysis Direction, Southbound.

Facility-wide Values table with columns: Jam Density (pc/h/ln), Time Period Duration (min), Facility Length (mi), 28.95900.

Segment Input Data

Time Period 1

Mainline Data table with columns: Seg #, From, To, Type, Length, Terrain, Adj. Demand, % Trucks, % RVs, # Lanes, FFS.

Ramp Data table with columns: Seg #, Type, Adj. Demand, % Trucks, % RVs, Lanes, Accel/Decel Length, FFS.

Weaving Segment Data table with columns: Seg #, Ramp to Ramp Prop, On-Ramp, Off-Ramp, Adj. Demand, % Trucks, % RVs, Lanes, FFS.

Time Period Independent Weaving Segment Data

Table with columns: Seg #, Configuration, Short Length, # Weaving Lanes, Min. Lane Changes Freeway Ramp, Min. Lane Changes Ramp-Freeway, Min. Lane Changes Ramp-Ramp.

Time Period Results

Time Period 1

Main Time Period Results table with columns: Seg #, From, To, Type, Adj. Demand, Vol. Served, Capacity (pc/h), Capacity (veh/h), d/c Ratio, v/c ratio, Queue Length (ft), Avg. Speed (mi/h), Density (pc/mi/ln), Density (veh/mi/ln), Avg. Travel Time (min/veh), Free-Flow Travel Time (min/veh), Mainline Delay (min/veh), System Delay (min/veh), VMT Demand (veh-mi), VMT Volume (veh-mi), VHD (veh-hrs), VHD Volume (veh-hrs).

Overall Results

Summary table with columns: Segment, Segment Type, Maximum d/c Ratio, Avg. Speed (mi/h), Density (pc/mi/ln), Density (veh/mi/ln), Avg. Travel Time (min/veh), Free-Flow Travel Time (min/veh), VMT Demand (veh-mi), VMT Volume (veh-mi), VHD (veh-hrs), VHD Volume (veh-hrs).

M4	OnRamp	0.63	59.3	24.8	22.4	0.29	0.26	0.379.5	0.379.5	6.40	0.57
B5	Basic	0.63	64.9	22.8	20.6	3.28	3.28	4,743.4	4,743.4	73.08	0.10
D6	OffRamp	0.63	62.4	23.7	21.4	0.27	0.26	0.379.5	0.379.5	6.09	0.25
NC 146 - LONG SHOALS- B7	Basic	0.49	64.9	17.9	15.9	0.44	0.44	0,487.1	0,487.1	7.51	0.01
M8	OnRamp	0.59	59.6	23.1	20.7	0.29	0.26	0.353.7	0.353.7	5.93	0.49
B9	Basic	0.59	65.0	21.3	19.2	1.84	1.84	2,475.9	2,475.9	38.09	0.00
D10	OffRamp	0.59	60.5	22.9	20.6	0.28	0.26	0.353.7	0.353.7	5.85	0.40
NC 280 - AIRPORT RD-B11	Basic	0.43	64.8	15.5	13.6	0.40	0.40	0.379.0	0.379.0	5.85	0.02
M12	OnRamp	0.54	59.6	21.2	19.0	0.29	0.26	0.325.0	0.325.0	5.45	0.45
B13	Basic	0.54	64.0	20.0	17.9	0.09	0.09	0,113.8	0,113.8	1.78	0.03
D14	OffRamp	0.54	63.6	20.1	18.0	0.27	0.26	0.325.0	0.325.0	5.11	0.11
AREA SB B15	Basic	0.52	64.9	18.7	16.8	0.30	0.30	0,356.1	0,356.1	5.49	0.01
M16	OnRamp	0.54	60.4	21.0	18.7	0.28	0.26	0.325.0	0.325.0	5.38	0.38
B17	Basic	0.54	65.0	19.7	17.6	1.23	1.23	1,527.5	1,527.5	23.50	0.00
D18	OffRamp	0.54	61.6	20.8	18.6	0.28	0.26	0.325.0	0.325.0	5.28	0.28
US 25 - ASHEVILLE HWY-B19	Basic	0.43	64.8	15.5	13.6	0.36	0.36	0,346.2	0,346.2	5.34	0.02
M20	OnRamp	0.51	60.1	19.7	17.6	0.28	0.26	0.303.3	0.303.3	5.04	0.38
B21	Basic	0.50	70.0	17.1	15.3	1.11	1.11	1,379.9	1,379.9	19.72	0.00
D22	OffRamp	0.50	66.6	18.0	16.0	0.26	0.24	0.303.3	0.303.3	4.56	0.22
WILSON STATION SB-B23	Basic	0.42	69.7	14.5	14.2	0.24	0.24	0,281.6	0,281.6	4.04	0.02
M24	OnRamp	0.50	65.1	16.6	14.8	0.26	0.24	0.303.3	0.303.3	4.66	0.33
B25	Basic	0.50	70.0	17.1	15.3	1.08	1.08	1,349.5	1,349.5	19.28	0.00
D26	OffRamp	0.50	67.7	17.7	15.8	0.25	0.24	0.303.3	0.303.3	4.48	0.15
D27	OffRamp	0.46	69.0	18.1	15.9	0.26	0.24	0,276.5	0,276.5	4.59	0.58
BALFOUR PROXY-B28	Basic	0.37	68.8	12.8	11.1	0.17	0.16	0,144.2	0,144.2	2.10	0.04
M29	OnRamp	0.47	64.9	17.3	15.3	0.26	0.24	0,265.6	0,265.6	4.37	0.32
B30	Basic	0.47	69.5	16.2	14.4	0.23	0.23	0,269.4	0,269.4	3.88	0.03
D31	OffRamp	0.47	68.8	16.4	14.5	0.25	0.24	0,283.6	0,283.6	4.12	0.07
B32	Basic	0.43	69.8	14.6	12.8	0.10	0.10	0,101.6	0,101.6	1.46	0.00
US 84 - 4 SEASONS BL-W33	Weaving	0.49	55.2	16.6	14.7	0.29	0.23	0,268.5	0,268.5	4.87	1.03
B34	Basic	0.40	66.0	14.5	12.6	0.04	0.04	0,035.5	0,035.5	0.54	0.03
M35	OnRamp	0.44	64.8	16.1	14.1	0.26	0.24	0,261.1	0,261.1	4.03	0.30
B36	Basic	0.44	70.0	14.9	13.1	2.18	2.18	2,332.3	2,332.3	33.32	0.00
D37	OffRamp	0.44	66.2	15.8	13.9	0.26	0.24	0,261.1	0,261.1	3.94	0.22
UPWARD RD-B38	Basic	0.35	69.8	11.9	10.2	0.37	0.37	0,309.7	0,309.7	4.44	0.01
M39	OnRamp	0.41	65.1	15.7	13.3	0.25	0.23	0,224.7	0,224.7	3.61	0.25
D40	OffRamp	0.43	60.7	15.8	13.7	0.27	0.23	0,234.7	0,234.7	3.87	0.51
US 25 - STYLER RD-B41	Basic	0.60	69.3	20.8	18.1	0.45	0.44	0,323.9	0,323.9	4.67	0.05
M42	OnRamp	0.61	62.3	23.3	20.3	0.27	0.24	0,179.9	0,179.9	2.89	0.32
B43	Basic	0.61	69.2	21.0	18.3	3.55	3.51	2,993.6	2,993.6	37.45	0.40
D44	OffRamp	0.61	61.1	23.8	20.7	0.28	0.24	0,179.9	0,179.9	2.94	0.37
HOLBERT COVE RD- B45	Basic	0.56	69.7	19.4	16.8	0.42	0.42	0,287.8	0,287.8	4.13	0.02
M46	OnRamp	0.60	61.1	23.3	20.3	0.28	0.24	0,176.8	0,176.8	2.89	0.37
END PROJECT SB-B47	Basic	0.60	69.4	20.6	17.9	0.86	0.86	0,622.3	0,622.3	8.97	0.08
Freeway			65.8	19.3	17.2	26.26	25.65	28,779.4	28,779.4	0,437.7	0,009.8

Density-Based LOS by Segment															
Segment	1	2	3	4	5	6	7	8	9	10	11	12	13	14	15
Time Step	Basic	Off Ramp	Basic	On Ramp	Basic	Off Ramp	Basic	On Ramp	Basic	Off Ramp	Basic	On Ramp	Basic	Off Ramp	Basic
1	C	C	C	C	C	C	B	C	C	C	B	C	C	C	C
Density-Based LOS by Segment															
Segment	16	17	18	19	20	21	22	23	24	25	26	27	28	29	30
Time Step	On Ramp	Basic	Off Ramp	Basic	On Ramp	Basic	Off Ramp	Basic	On Ramp	Basic	Off Ramp	Off Ramp	Basic	On Ramp	Basic
1	C	C	C	C	B	B	B	B	B	B	B	B	B	B	B
Density-Based LOS by Segment															
Segment	31	32	33	34	35	36	37	38	39	40	41	42	43	44	45
Time Step	Off Ramp	Basic	Weaving	Basic	On Ramp	Basic	Off Ramp	Basic	On Ramp	Off Ramp	Basic	On Ramp	Basic	Off Ramp	Basic
1	B	B	B	B	B	B	B	B	B	D	C	C	C	C	C
Density-Based LOS by Segment															
Segment	46	47													
Time Step	On Ramp	Basic													
1	C	C													
Demand-Based LOS by Segment															
Time Step	1	2	3	4	5	6	7	8	9	10	11	12	13	14	15
1	-	-	-	-	-	-	-	-	-	-	-	-	-	-	-
Demand-Based LOS by Segment															
Time Step	16	17	18	19	20	21	22	23	24	25	26	27	28	29	30
1	-	-	-	-	-	-	-	-	-	-	-	-	-	-	-
Demand-Based LOS by Segment															
Time Step	31	32	33	34	35	36	37	38	39	40	41	42	43	44	45
1	-	-	-	-	-	-	-	-	-	-	-	-	-	-	-
Demand-Based LOS by Segment															
Time Step	46	47													
1	-	-													

Appendix D – SYNCHRO Signalized Analysis Output

2011 No-Build

Lanes, Volumes, Timings
1: NC 146 (Long Shoals Rd) & I-26 NB On-Ramp

2011 Base Year - No Build
Timing Plan: AM Peak

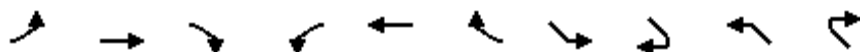

Lane Group	EBL	EBT	EBR2	WBL	WBT	WBR2	SEL	SER2	NWL	NWR2
Lane Configurations	↗↗	↑↑	↖	↗↗	↑↑	↖	↗↗	↖	↗↗	↖
Volume (vph)	141	466	178	495	618	663	637	179	181	379
Ideal Flow (vphpl)	1900	1900	1900	1900	1900	1900	1900	1900	1900	1900
Grade (%)		3%			-7%					
Storage Length (ft)	450			350			0		675	
Storage Lanes	1			2			2		1	
Taper Length (ft)	100			100			100		100	
Lane Util. Factor	0.97	0.95	1.00	0.97	0.95	1.00	0.97	1.00	0.97	1.00
Frt			0.850			0.850		0.850		0.850
Flt Protected	0.950			0.950			0.950		0.950	
Satd. Flow (prot)	3224	3486	1487	3387	3628	1562	3519	1607	3434	1599
Flt Permitted	0.950			0.950			0.950		0.950	
Satd. Flow (perm)	3224	3486	1487	3387	3628	1562	3519	1607	3434	1599
Right Turn on Red			No			No		No		No
Satd. Flow (RTOR)										
Link Speed (mph)		45			45					
Link Distance (ft)		1009			964					
Travel Time (s)		15.3			14.6					
Peak Hour Factor	0.90	0.90	0.90	0.90	0.90	0.90	0.90	0.90	0.90	0.90
Heavy Vehicles (%)	7%	2%	7%	7%	3%	7%	2%	3%	3%	2%
Adj. Flow (vph)	157	518	198	550	687	737	708	199	201	421
Shared Lane Traffic (%)										
Lane Group Flow (vph)	157	518	198	550	687	737	708	199	201	421
Turn Type	Prot		Free	Prot		Free	Prot	custom	Prot	Free
Protected Phases	5	2		1	6		4		8	
Permitted Phases			Free			Free		4		Free
Detector Phase	5	2		1	6		4	4	8	
Switch Phase										
Minimum Initial (s)	7.0	12.0		7.0	12.0		7.0	7.0	7.0	
Minimum Split (s)	16.0	20.0		15.0	21.0		16.0	16.0	15.0	
Total Split (s)	20.0	38.0	0.0	22.0	40.0	0.0	30.0	30.0	30.0	0.0
Total Split (%)	22.2%	42.2%	0.0%	24.4%	44.4%	0.0%	33.3%	33.3%	33.3%	0.0%
Maximum Green (s)	11.8	30.5		14.3	31.0		21.9	21.9	22.0	
Yellow Time (s)	3.4	4.3		4.0	5.2		3.8	3.8	3.7	
All-Red Time (s)	4.8	3.2		3.7	3.8		4.3	4.3	4.3	
Lost Time Adjust (s)	-3.2	-2.5	-2.5	-2.7	-4.0	-4.0	-3.1	-3.1	-3.0	0.0
Total Lost Time (s)	5.0	5.0	1.5	5.0	5.0	0.0	5.0	5.0	5.0	4.0
Lead/Lag	Lead	Lag		Lead	Lag					
Lead-Lag Optimize?	Yes	Yes		Yes	Yes					
Vehicle Extension (s)	2.0	6.0		2.0	6.0		2.0	2.0	2.0	
Minimum Gap (s)	3.0	3.0		3.0	3.0		3.0	3.0	3.0	
Time Before Reduce (s)	0.0	15.0		0.0	15.0		0.0	0.0	0.0	
Time To Reduce (s)	0.0	30.0		0.0	30.0		0.0	0.0	0.0	
Recall Mode	None	C-Max		None	C-Max		None	None	None	
Act Effct Green (s)	12.1	33.9	90.0	17.4	39.2	90.0	23.6	23.6	23.6	90.0
Actuated g/C Ratio	0.13	0.38	1.00	0.19	0.44	1.00	0.26	0.26	0.26	1.00
v/c Ratio	0.36	0.39	0.13	0.84	0.43	0.47	0.77	0.47	0.22	0.26
Control Delay	37.4	21.9	0.2	48.2	19.4	1.0	36.7	31.8	26.3	0.4
Queue Delay	0.0	0.0	0.0	0.0	0.0	0.0	0.0	0.0	0.0	0.0

Lanes, Volumes, Timings
 1: NC 146 (Long Shoals Rd) & I-26 NB On-Ramp

2011 Base Year - No Build
 Timing Plan: AM Peak

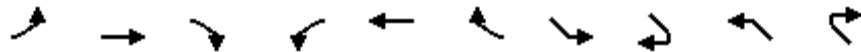

Lane Group	EBL	EBT	EBR2	WBL	WBT	WBR2	SEL	SER2	NWL	NWR2
Total Delay	37.4	21.9	0.2	48.2	19.4	1.0	36.7	31.8	26.3	0.4
LOS	D	C	A	D	B	A	D	C	C	A
Approach Delay	19.8			20.6						
Approach LOS	B			C						
Queue Length 50th (ft)	42	113	0	157	142	0	187	93	44	0
Queue Length 95th (ft)	69	157	0	#243	202	0	250	158	73	0
Internal Link Dist (ft)	929			884						
Turn Bay Length (ft)	450		300	350		300		425	675	575
Base Capacity (vph)	537	1314	1487	656	1581	1562	978	446	954	1599
Starvation Cap Reductn	0	0	0	0	0	0	0	0	0	0
Spillback Cap Reductn	0	0	0	0	0	0	0	0	0	0
Storage Cap Reductn	0	0	0	0	0	0	0	0	0	0
Reduced v/c Ratio	0.29	0.39	0.13	0.84	0.43	0.47	0.72	0.45	0.21	0.26

Intersection Summary

Area Type: Other
 Cycle Length: 90
 Actuated Cycle Length: 90
 Offset: 52 (58%), Referenced to phase 2:EBT and 6:WBT, Start of Green
 Natural Cycle: 60
 Control Type: Actuated-Coordinated
 Maximum v/c Ratio: 0.84
 Intersection Signal Delay: 21.8
 Intersection LOS: C
 Intersection Capacity Utilization 57.7%
 ICU Level of Service B
 Analysis Period (min) 15
 # 95th percentile volume exceeds capacity, queue may be longer.
 Queue shown is maximum after two cycles.

Splits and Phases: 1: NC 146 (Long Shoals Rd) & I-26 NB On-Ramp

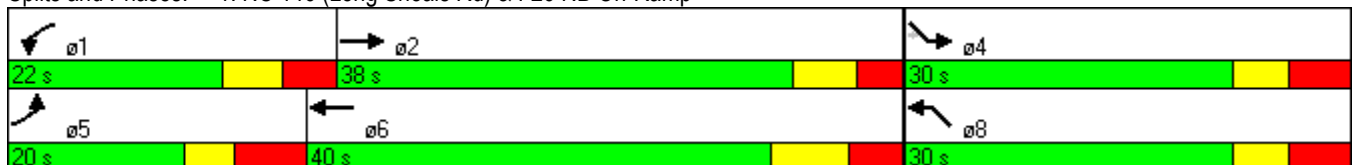

Lanes, Volumes, Timings
 2: I-26 NB On-Ramp & US 25 (Asheville Highway)

2011 Base Year - No Build
 Timing Plan: AM Peak



Lane Group	EBL	EBT	EBR	WBL	WBT	WBR	NBL	NBT	NBR	SBL	SBT	SBR
Lane Configurations				↙		↗	↙	↗			↗	↙
Volume (vph)	0	0	0	123	0	320	465	860	0	0	1244	193
Ideal Flow (vphpl)	1900	1900	1900	1900	1900	1900	1900	1900	1900	1900	1900	1900
Grade (%)		0%			2%			-1%			2%	
Storage Length (ft)	0		0	0		150	0		0	0		300
Storage Lanes	0		0	1		2	1		0	0		1
Taper Length (ft)	100		100	100		100	100		100	100		100
Lane Util. Factor	1.00	1.00	1.00	1.00	1.00	0.88	1.00	0.95	1.00	1.00	0.95	1.00
Frt						0.850						0.850
Flt Protected				0.950			0.950					
Satd. Flow (prot)	0	0	0	1735	0	2706	1680	3489	0	0	3436	1480
Flt Permitted				0.950			0.950					
Satd. Flow (perm)	0	0	0	1735	0	2706	1680	3489	0	0	3436	1480
Right Turn on Red			No			Yes			No			No
Satd. Flow (RTOR)						356						
Link Speed (mph)		45			35			45				45
Link Distance (ft)		533			612			601				596
Travel Time (s)		8.1			11.9			9.1				9.0
Peak Hour Factor	0.90	0.90	0.90	0.90	0.90	0.90	0.90	0.90	0.90	0.90	0.90	0.90
Heavy Vehicles (%)	5%	5%	5%	3%	5%	4%	8%	4%	5%	5%	4%	8%
Adj. Flow (vph)	0	0	0	137	0	356	517	956	0	0	1382	214
Shared Lane Traffic (%)												
Lane Group Flow (vph)	0	0	0	137	0	356	517	956	0	0	1382	214
Turn Type				Prot		custom	Prot					Free
Protected Phases				4			5	2				6
Permitted Phases						4						Free
Detector Phase				4		4	5	2				6
Switch Phase												
Minimum Initial (s)				7.0		7.0	7.0	12.0				12.0
Minimum Split (s)				13.0		13.0	14.0	19.0				18.0
Total Split (s)	0.0	0.0	0.0	20.0	0.0	20.0	48.0	90.0	0.0	0.0	42.0	0.0
Total Split (%)	0.0%	0.0%	0.0%	18.2%	0.0%	18.2%	43.6%	81.8%	0.0%	0.0%	38.2%	0.0%
Maximum Green (s)				14.0		14.0	41.6	83.9				36.7
Yellow Time (s)				3.7		3.7	3.0	4.6				4.3
All-Red Time (s)				2.3		2.3	3.4	1.5				1.0
Lost Time Adjust (s)	-2.0	0.0	0.0	-1.0	0.0	-1.0	-1.4	-1.1	0.0	0.0	-0.3	0.0
Total Lost Time (s)	2.0	4.0	4.0	5.0	4.0	5.0	5.0	5.0	4.0	4.0	5.0	4.0
Lead/Lag							Lag					Lead
Lead-Lag Optimize?							Yes					Yes
Vehicle Extension (s)				2.0		2.0	2.0	8.0				8.0
Minimum Gap (s)				3.0		3.0	3.0	5.5				5.5
Time Before Reduce (s)				0.0		0.0	0.0	15.0				15.0
Time To Reduce (s)				0.0		0.0	0.0	50.0				50.0
Recall Mode				None		None	None	C-Max				C-Max
Act Effct Green (s)				12.9		12.9	43.0	87.1				39.1 110.0
Actuated g/C Ratio				0.12		0.12	0.39	0.79				0.36 1.00
v/c Ratio				0.67		0.56	0.79	0.35				1.13 0.14
Control Delay				62.8		8.3	24.4	0.1				103.7 0.2
Queue Delay				0.0		0.0	0.0	0.0				0.0 0.0

Lanes, Volumes, Timings
 2: I-26 NB On-Ramp & US 25 (Asheville Highway)

2011 Base Year - No Build
 Timing Plan: AM Peak



Lane Group	EBL	EBT	EBR	WBL	WBT	WBR	NBL	NBT	NBR	SBL	SBT	SBR
Total Delay				62.8		8.3	24.5	0.1			103.7	0.2
LOS				E		A	C	A			F	A
Approach Delay								8.7			89.9	
Approach LOS								A			F	
Queue Length 50th (ft)				93		0	395	0			~611	0
Queue Length 95th (ft)				157		46	m430	m0			#760	0
Internal Link Dist (ft)		453			532			521			516	
Turn Bay Length (ft)						150						300
Base Capacity (vph)				237		676	657	2763			1222	1480
Starvation Cap Reductn				0		0	2	0			0	0
Spillback Cap Reductn				0		0	0	0			0	0
Storage Cap Reductn				0		0	0	0			0	0
Reduced v/c Ratio				0.58		0.53	0.79	0.35			1.13	0.14

Intersection Summary

Area Type: Other
 Cycle Length: 110
 Actuated Cycle Length: 110
 Offset: 103 (94%), Referenced to phase 2:NBT and 6:SBT, Start of Green
 Natural Cycle: 90
 Control Type: Actuated-Coordinated
 Maximum v/c Ratio: 1.13
 Intersection Signal Delay: 47.1
 Intersection LOS: D
 Intersection Capacity Utilization 79.5%
 ICU Level of Service D
 Analysis Period (min) 15
 ~ Volume exceeds capacity, queue is theoretically infinite.
 Queue shown is maximum after two cycles.
 # 95th percentile volume exceeds capacity, queue may be longer.
 Queue shown is maximum after two cycles.
 m Volume for 95th percentile queue is metered by upstream signal.

Splits and Phases: 2: I-26 NB On-Ramp & US 25 (Asheville Highway)

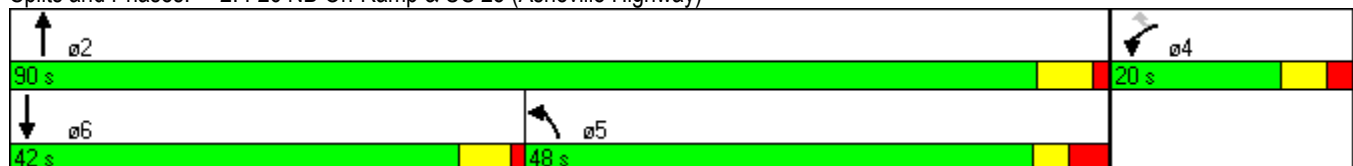

Lanes, Volumes, Timings
 3: I-26 SB Off-Ramp & US 25 (Asheville Highway)

2011 Base Year - No Build

Timing Plan: AM Peak



Lane Group	EBL	EBT	EBR	WBL	WBT	WBR	NBL	NBT	NBR	SBL	SBT	SBR
Lane Configurations	↖		↖					↗	↖	↖	↗	
Volume (vph)	190	0	576	0	0	0	0	1135	123	401	966	0
Ideal Flow (vphpl)	1900	1900	1900	1900	1900	1900	1900	1900	1900	1900	1900	1900
Grade (%)		3%			0%			4%			1%	
Storage Length (ft)	0		100	0		0	0		500	0		0
Storage Lanes	1		1	0		0	0		1	1		0
Taper Length (ft)	100		100	100		100	100		100	100		100
Lane Util. Factor	1.00	1.00	1.00	1.00	1.00	1.00	1.00	0.95	1.00	1.00	0.95	1.00
Frt			0.850						0.850			
Flt Protected	0.950									0.950		
Satd. Flow (prot)	1710	0	1544	0	0	0	0	3435	1465	1663	3487	0
Flt Permitted	0.950									0.950		
Satd. Flow (perm)	1710	0	1544	0	0	0	0	3435	1465	1663	3487	0
Right Turn on Red			No			No			No			No
Satd. Flow (RTOR)												
Link Speed (mph)		35			45			45			45	
Link Distance (ft)		471			598			795			601	
Travel Time (s)		9.2			9.1			12.0			9.1	
Peak Hour Factor	0.90	0.90	0.90	0.90	0.90	0.90	0.90	0.90	0.90	0.90	0.90	0.90
Heavy Vehicles (%)	4%	5%	3%	5%	5%	5%	5%	3%	8%	8%	3%	5%
Adj. Flow (vph)	211	0	640	0	0	0	0	1261	137	446	1073	0
Shared Lane Traffic (%)												
Lane Group Flow (vph)	211	0	640	0	0	0	0	1261	137	446	1073	0
Turn Type	Prot		custom						Free	Prot		
Protected Phases	4		4					2		1	6	
Permitted Phases									Free			
Detector Phase	4		4					2		1	6	
Switch Phase												
Minimum Initial (s)	7.0		7.0					12.0		7.0	12.0	
Minimum Split (s)	13.0		13.0					18.0		14.0	18.0	
Total Split (s)	22.0	0.0	22.0	0.0	0.0	0.0	0.0	48.0	0.0	40.0	88.0	0.0
Total Split (%)	20.0%	0.0%	20.0%	0.0%	0.0%	0.0%	0.0%	43.6%	0.0%	36.4%	80.0%	0.0%
Maximum Green (s)	16.0		16.0					42.3		33.5	82.3	
Yellow Time (s)	4.0		4.0					4.7		4.0	4.7	
All-Red Time (s)	2.0		2.0					1.0		2.5	1.0	
Lost Time Adjust (s)	-1.0	-2.0	-1.0	-2.0	-2.0	-2.0	-2.0	-0.7	-0.7	-1.5	-0.7	-2.0
Total Lost Time (s)	5.0	2.0	5.0	2.0	2.0	2.0	2.0	5.0	3.3	5.0	5.0	2.0
Lead/Lag								Lead		Lag		
Lead-Lag Optimize?								Yes		Yes		
Vehicle Extension (s)	2.0		2.0					8.0		2.0	8.0	
Minimum Gap (s)	3.0		3.0					5.5		3.0	5.5	
Time Before Reduce (s)	0.0		0.0					15.0		0.0	15.0	
Time To Reduce (s)	0.0		0.0					50.0		0.0	50.0	
Recall Mode	None		None					C-Max		None	C-Max	
Act Effct Green (s)	17.0		17.0					43.0	110.0	35.0	83.0	
Actuated g/C Ratio	0.15		0.15					0.39	1.00	0.32	0.75	
v/c Ratio	0.80		2.68					0.94	0.09	0.84	0.41	
Control Delay	67.7		787.4					46.6	0.1	56.2	9.1	
Queue Delay	0.0		0.0					0.0	0.0	0.0	1.7	

Lanes, Volumes, Timings
 3: I-26 SB Off-Ramp & US 25 (Asheville Highway)

2011 Base Year - No Build
 Timing Plan: AM Peak



Lane Group	EBL	EBT	EBR	WBL	WBT	WBR	NBL	NBT	NBR	SBL	SBT	SBR
Total Delay	67.7		787.4					46.6	0.1	56.2	10.8	
LOS	E		F					D	A	E	B	
Approach Delay								42.0			24.2	
Approach LOS								D			C	
Queue Length 50th (ft)	145		~767					444	0	341	256	
Queue Length 95th (ft)	#266		#988					#592	0	m314	m143	
Internal Link Dist (ft)		391			518			715				521
Turn Bay Length (ft)			100						500			
Base Capacity (vph)	264		239					1343	1465	529	2631	
Starvation Cap Reductn	0		0					0	0	0	1322	
Spillback Cap Reductn	0		0					0	0	0	0	
Storage Cap Reductn	0		0					0	0	0	0	
Reduced v/c Ratio	0.80		2.68					0.94	0.09	0.84	0.82	

Intersection Summary

Area Type: Other
 Cycle Length: 110
 Actuated Cycle Length: 110
 Offset: 8 (7%), Referenced to phase 2:NBT and 6:SBT, Start of Green
 Natural Cycle: 130
 Control Type: Actuated-Coordinated
 Maximum v/c Ratio: 2.68
 Intersection Signal Delay: 162.9
 Intersection LOS: F
 Intersection Capacity Utilization 79.5%
 ICU Level of Service D
 Analysis Period (min) 15
 ~ Volume exceeds capacity, queue is theoretically infinite.
 Queue shown is maximum after two cycles.
 # 95th percentile volume exceeds capacity, queue may be longer.
 Queue shown is maximum after two cycles.
 m Volume for 95th percentile queue is metered by upstream signal.

Splits and Phases: 3: I-26 SB Off-Ramp & US 25 (Asheville Highway)

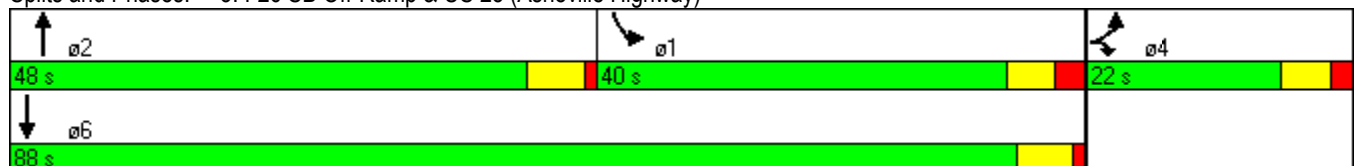

Lanes, Volumes, Timings
6: US 64 & SR 1516 (Francis Rd)

2011 Base Year - No Build
Timing Plan: AM Peak



Lane Group	EBL	EBT	EBR	WBL	WBT	WBR	NBL	NBT	NBR	SBL	SBT	SBR
Lane Configurations												
Volume (vph)	117	1470	375	89	1863	27	333	5	62	19	5	103
Ideal Flow (vphpl)	1900	1900	1900	1900	1900	1900	1900	1900	1900	1900	1900	1900
Grade (%)		-1%			4%			-1%			2%	
Storage Length (ft)	150		0	125		0	150		150	0		150
Storage Lanes	1		1	1		0	1		1	0		1
Taper Length (ft)	100		100	100		100	100		100	100		100
Lane Util. Factor	1.00	0.95	1.00	1.00	0.95	0.95	0.95	0.95	1.00	1.00	1.00	1.00
Frt			0.850			0.998			0.850			0.850
Flt Protected	0.950			0.950			0.950	0.954			0.963	
Satd. Flow (prot)	1778	3557	1591	1734	3461	0	1690	1697	1591	0	1776	1567
Flt Permitted	0.950			0.950			0.950	0.954			0.963	
Satd. Flow (perm)	1778	3557	1591	1734	3461	0	1690	1697	1591	0	1776	1567
Right Turn on Red			No			No			No			No
Satd. Flow (RTOR)												
Link Speed (mph)		45			45			35			35	
Link Distance (ft)		835			622			375			406	
Travel Time (s)		12.7			9.4			7.3			7.9	
Peak Hour Factor	0.90	0.90	0.90	0.90	0.90	0.90	0.90	0.90	0.90	0.90	0.90	0.90
Heavy Vehicles (%)	2%	2%	2%	2%	2%	2%	2%	2%	2%	2%	2%	2%
Adj. Flow (vph)	130	1633	417	99	2070	30	370	6	69	21	6	114
Shared Lane Traffic (%)							49%					
Lane Group Flow (vph)	130	1633	417	99	2100	0	189	187	69	0	27	114
Turn Type	Prot		Perm	Prot			Split		pm+ov	Split		pm+ov
Protected Phases	5	2		1	6		4	4	1	3	3	5
Permitted Phases			2						4			3
Detector Phase	5	2	2	1	6		4	4	1	3	3	5
Switch Phase												
Minimum Initial (s)	7.0	12.0	12.0	7.0	12.0		7.0	7.0	7.0	7.0	7.0	7.0
Minimum Split (s)	13.0	18.0	18.0	13.0	18.0		14.0	14.0	13.0	14.0	14.0	13.0
Total Split (s)	20.0	60.0	60.0	18.0	58.0	0.0	20.0	20.0	18.0	22.0	22.0	20.0
Total Split (%)	16.7%	50.0%	50.0%	15.0%	48.3%	0.0%	16.7%	16.7%	15.0%	18.3%	18.3%	16.7%
Maximum Green (s)	14.4	54.0	54.0	12.6	52.4		13.4	13.4	12.6	15.5	15.5	14.4
Yellow Time (s)	3.2	4.6	4.6	3.0	4.2		3.9	3.9	3.0	3.7	3.7	3.2
All-Red Time (s)	2.4	1.4	1.4	2.4	1.4		2.7	2.7	2.4	2.8	2.8	2.4
Lost Time Adjust (s)	-0.6	-1.0	-1.0	-0.4	-0.6	-2.0	-1.6	-1.6	-0.4	-2.0	-1.5	-0.6
Total Lost Time (s)	5.0	5.0	5.0	5.0	5.0	2.0	5.0	5.0	5.0	4.5	5.0	5.0
Lead/Lag	Lag	Lag	Lag	Lead	Lead		Lag	Lag	Lead	Lead	Lead	Lag
Lead-Lag Optimize?	Yes	Yes	Yes	Yes	Yes		Yes	Yes	Yes	Yes	Yes	Yes
Vehicle Extension (s)	1.0	2.0	2.0	1.0	2.0		1.0	1.0	1.0	1.0	1.0	1.0
Recall Mode	None	C-Max	C-Max	None	C-Max		None	None	None	None	None	None
Act Effct Green (s)	15.0	66.7	66.7	10.5	62.2		19.6	19.6	35.0		8.6	23.2
Actuated g/C Ratio	0.12	0.56	0.56	0.09	0.52		0.16	0.16	0.29		0.07	0.19
v/c Ratio	0.59	0.83	0.47	0.65	1.17		0.68	0.68	0.15		0.21	0.38
Control Delay	53.6	23.0	16.1	72.6	111.6		60.1	59.5	30.4		56.6	44.0
Queue Delay	0.0	0.0	0.0	0.0	0.0		0.0	0.0	0.0		0.0	0.0
Total Delay	53.6	23.0	16.1	72.6	111.6		60.1	59.5	30.4		56.6	44.0
LOS	D	C	B	E	F		E	E	C		E	D
Approach Delay		23.5			109.9			55.2			46.4	

Lanes, Volumes, Timings
6: US 64 & SR 1516 (Francis Rd)

2011 Base Year - No Build
Timing Plan: AM Peak



Lane Group	EBL	EBT	EBR	WBL	WBT	WBR	NBL	NBT	NBR	SBL	SBT	SBR
Approach LOS	C			F			E			D		
Queue Length 50th (ft)	95	503	128	75	~1096		145	144	39		20	73
Queue Length 95th (ft)	159	#825	259	132	#1270		225	223	72		51	127
Internal Link Dist (ft)	755			542			295			326		
Turn Bay Length (ft)	150			125			150			150		
Base Capacity (vph)	222	1978	884	188	1794		278	279	498		252	303
Starvation Cap Reductn	0	0	0	0	0		0	0	0		0	0
Spillback Cap Reductn	0	0	0	0	0		0	0	0		0	0
Storage Cap Reductn	0	0	0	0	0		0	0	0		0	0
Reduced v/c Ratio	0.59	0.83	0.47	0.53	1.17		0.68	0.67	0.14		0.11	0.38

Intersection Summary

Area Type: Other
 Cycle Length: 120
 Actuated Cycle Length: 120
 Offset: 82 (68%), Referenced to phase 2:EBT and 6:WBT, Start of Green
 Natural Cycle: 130
 Control Type: Actuated-Coordinated
 Maximum v/c Ratio: 1.17
 Intersection Signal Delay: 65.2
 Intersection LOS: E
 Intersection Capacity Utilization 87.4%
 ICU Level of Service E
 Analysis Period (min) 15
 ~ Volume exceeds capacity, queue is theoretically infinite.
 Queue shown is maximum after two cycles.
 # 95th percentile volume exceeds capacity, queue may be longer.
 Queue shown is maximum after two cycles.

Splits and Phases: 6: US 64 & SR 1516 (Francis Rd)

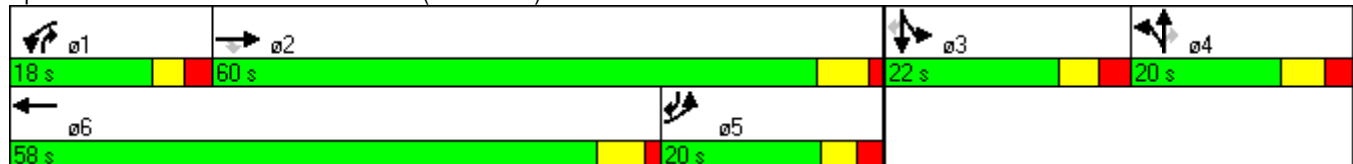

Lanes, Volumes, Timings
7: US 64 & I-26 SB Off-Ramp

2011 Base Year - No Build

Timing Plan: AM Peak

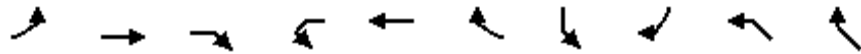

Lane Group	EBL	EBT	EBR	WBL	WBT	WBR	SBL	SBR	NWL	NWR
Lane Configurations		↑↑	↑		↑↑			↑↑		
Volume (vph)	0	1440	253	0	1716	0	0	373	0	0
Ideal Flow (vphpl)	1900	1900	1900	1900	1900	1900	1900	1900	1900	1900
Grade (%)		3%			-3%		-3%		0%	
Storage Length (ft)	0		400	0		0	0	500	0	0
Storage Lanes	0		1	0		0	0	1	0	0
Taper Length (ft)	100		100	100		100	100	100	100	100
Lane Util. Factor	1.00	0.95	1.00	1.00	0.95	1.00	1.00	0.88	1.00	1.00
Frt			0.850					0.850		
Flt Protected										
Satd. Flow (prot)	0	3486	1473	0	3592	0	0	2828	0	0
Flt Permitted										
Satd. Flow (perm)	0	3486	1473	0	3592	0	0	2828	0	0
Right Turn on Red			No			No		No		
Satd. Flow (RTOR)										
Link Speed (mph)		45			45		35		45	
Link Distance (ft)		728			791		804		308	
Travel Time (s)		11.0			12.0		15.7		4.7	
Peak Hour Factor	0.90	0.90	0.90	0.90	0.90	0.90	0.90	0.90	0.90	0.90
Heavy Vehicles (%)	5%	2%	8%	5%	2%	5%	5%	2%	5%	5%
Adj. Flow (vph)	0	1600	281	0	1907	0	0	414	0	0
Shared Lane Traffic (%)										
Lane Group Flow (vph)	0	1600	281	0	1907	0	0	414	0	0
Turn Type			Perm					custom		
Protected Phases		Free			6			4		
Permitted Phases			Free							
Detector Phase					6			4		
Switch Phase										
Minimum Initial (s)					12.0			7.0		
Minimum Split (s)					18.0			13.0		
Total Split (s)	0.0	0.0	0.0	0.0	90.0	0.0	0.0	30.0	0.0	0.0
Total Split (%)	0.0%	0.0%	0.0%	0.0%	75.0%	0.0%	0.0%	25.0%	0.0%	0.0%
Maximum Green (s)					84.2			24.9		
Yellow Time (s)					4.8			4.1		
All-Red Time (s)					1.0			1.0		
Lost Time Adjust (s)	-2.0	0.0	-2.0	-2.0	-0.8	-2.0	-2.0	-0.1	-2.0	-2.0
Total Lost Time (s)	2.0	4.0	2.0	2.0	5.0	2.0	2.0	5.0	2.0	2.0
Lead/Lag										
Lead-Lag Optimize?										
Vehicle Extension (s)					2.0			1.0		
Recall Mode					C-Max			None		
Act Effct Green (s)		120.0	120.0		89.3			20.7		
Actuated g/C Ratio		1.00	1.00		0.74			0.17		
v/c Ratio		0.46	0.19		0.71			0.85		
Control Delay		0.2	0.1		16.3			64.6		
Queue Delay		0.0	0.0		0.0			0.0		
Total Delay		0.2	0.1		16.3			64.6		
LOS		A	A		B			E		
Approach Delay		0.2			16.3					

Lanes, Volumes, Timings
7: US 64 & I-26 SB Off-Ramp

2011 Base Year - No Build

Timing Plan: AM Peak

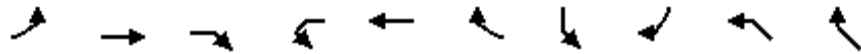

Lane Group	EBL	EBT	EBR	WBL	WBT	WBR	SBL	SBR	NWL	NWR
Approach LOS		A						B		
Queue Length 50th (ft)		0	0		703			177		
Queue Length 95th (ft)		m0	m0		m677			232		
Internal Link Dist (ft)		648			711		724		228	
Turn Bay Length (ft)			400					500		
Base Capacity (vph)		3486	1473		2674			589		
Starvation Cap Reductn		0	0		0			0		
Spillback Cap Reductn		0	0		38			0		
Storage Cap Reductn		0	0		0			0		
Reduced v/c Ratio		0.46	0.19		0.72			0.70		

Intersection Summary

Area Type: Other
 Cycle Length: 120
 Actuated Cycle Length: 120
 Offset: 0 (0%), Referenced to phase 6:WBT, Start of Green, Master Intersection
 Natural Cycle: 60
 Control Type: Actuated-Coordinated
 Maximum v/c Ratio: 0.85
 Intersection Signal Delay: 13.9
 Intersection LOS: B
 Intersection Capacity Utilization 75.1%
 ICU Level of Service D
 Analysis Period (min) 15
 m Volume for 95th percentile queue is metered by upstream signal.

Splits and Phases: 7: US 64 & I-26 SB Off-Ramp



Lanes, Volumes, Timings
 8: US 64 & SR 1634 (Carolina Village Rd)

2011 Base Year - No Build
 Timing Plan: AM Peak



Lane Group	EBL	EBT	EBR	WBL	WBT	WBR	NBL	NBT	NBR	SBL	SBT	SBR
Lane Configurations												
Volume (vph)	58	1481	69	139	1829	106	66	15	107	117	22	79
Ideal Flow (vphpl)	1900	1900	1900	1900	1900	1900	1900	1900	1900	1900	1900	1900
Grade (%)		1%			-3%			3%				-1%
Storage Length (ft)	100		0	100		0	0		0	0		150
Storage Lanes	1		0	1		1	0		0	0		1
Taper Length (ft)	100		100	100		100	100		100	100		100
Lane Util. Factor	1.00	0.95	0.95	1.00	0.95	1.00	1.00	1.00	1.00	1.00	1.00	1.00
Frt		0.993				0.850		0.923				0.850
Flt Protected	0.950			0.950				0.983			0.960	
Satd. Flow (prot)	1761	3497	0	1796	3592	1607	0	1665	0	0	1797	1591
Flt Permitted	0.950			0.950				0.655			0.497	
Satd. Flow (perm)	1761	3497	0	1796	3592	1607	0	1109	0	0	930	1591
Right Turn on Red			No			No			No			No
Satd. Flow (RTOR)												
Link Speed (mph)		45			45			30			30	
Link Distance (ft)		560			728			219			359	
Travel Time (s)		8.5			11.0			5.0			8.2	
Peak Hour Factor	0.90	0.90	0.90	0.90	0.90	0.90	0.90	0.90	0.90	0.90	0.90	0.90
Heavy Vehicles (%)	2%	2%	2%	2%	2%	2%	2%	2%	2%	2%	2%	2%
Adj. Flow (vph)	64	1646	77	154	2032	118	73	17	119	130	24	88
Shared Lane Traffic (%)												
Lane Group Flow (vph)	64	1723	0	154	2032	118	0	209	0	0	154	88
Turn Type	Prot			Prot		Perm	Perm			Perm		pm+ov
Protected Phases	5	2		1	6			8			4	5
Permitted Phases						6	8			4		4
Detector Phase	5	2		1	6	6	8	8		4	4	5
Switch Phase												
Minimum Initial (s)	7.0	12.0		7.0	12.0	12.0	7.0	7.0		7.0	7.0	7.0
Minimum Split (s)	13.0	18.0		13.0	19.0	19.0	13.0	13.0		13.0	13.0	13.0
Total Split (s)	23.0	71.0	0.0	23.0	71.0	71.0	26.0	26.0	0.0	26.0	26.0	23.0
Total Split (%)	19.2%	59.2%	0.0%	19.2%	59.2%	59.2%	21.7%	21.7%	0.0%	21.7%	21.7%	19.2%
Maximum Green (s)	17.1	65.4		17.6	64.8	64.8	20.2	20.2		20.1	20.1	17.1
Yellow Time (s)	3.0	4.4		3.0	4.8	4.8	3.4	3.4		3.6	3.6	3.0
All-Red Time (s)	2.9	1.2		2.4	1.4	1.4	2.4	2.4		2.3	2.3	2.9
Lost Time Adjust (s)	-0.9	-0.6	-2.0	-0.4	-1.2	-1.2	-2.0	-0.8	-2.0	-2.0	-0.9	-0.9
Total Lost Time (s)	5.0	5.0	2.0	5.0	5.0	5.0	3.8	5.0	2.0	3.9	5.0	5.0
Lead/Lag	Lag	Lag		Lead	Lead	Lead						Lag
Lead-Lag Optimize?	Yes	Yes		Yes	Yes	Yes						Yes
Vehicle Extension (s)	1.0	2.0		1.0	2.0	2.0	1.0	1.0		1.0	1.0	1.0
Recall Mode	None	C-Max		None	C-Max	C-Max	None	None		None	None	None
Act Effct Green (s)	18.0	70.3		13.7	66.0	66.0		21.0			21.0	44.0
Actuated g/C Ratio	0.15	0.59		0.11	0.55	0.55		0.18			0.18	0.37
v/c Ratio	0.24	0.84		0.75	1.03	0.13		1.08			0.94	0.15
Control Delay	47.8	25.9		72.0	46.9	8.3		133.7			107.1	26.4
Queue Delay	0.0	0.0		0.0	12.0	0.0		0.0			0.0	0.0
Total Delay	47.8	25.9		72.0	58.9	8.3		133.7			107.1	26.4
LOS	D	C		E	E	A		F			F	C
Approach Delay		26.7			57.2			133.7			77.8	

Lanes, Volumes, Timings
 8: US 64 & SR 1634 (Carolina Village Rd)

2011 Base Year - No Build
 Timing Plan: AM Peak



Lane Group	EBL	EBT	EBR	WBL	WBT	WBR	NBL	NBT	NBR	SBL	SBT	SBR
Approach LOS	C			E			F			E		
Queue Length 50th (ft)	44	547		110	~911	26		~180			119	45
Queue Length 95th (ft)	87	718		m157	#1015	m41		#335			#254	84
Internal Link Dist (ft)		480			648			139			279	
Turn Bay Length (ft)	100			100								150
Base Capacity (vph)	264	2048		269	1976	884		194			163	583
Starvation Cap Reductn	0	0		0	59	0		0			0	0
Spillback Cap Reductn	0	0		0	0	0		0			0	0
Storage Cap Reductn	0	0		0	0	0		0			0	0
Reduced v/c Ratio	0.24	0.84		0.57	1.06	0.13		1.08			0.94	0.15

Intersection Summary

Area Type: Other
 Cycle Length: 120
 Actuated Cycle Length: 120
 Offset: 31 (26%), Referenced to phase 2:EBT and 6:WBT, Start of Green
 Natural Cycle: 90
 Control Type: Actuated-Coordinated
 Maximum v/c Ratio: 1.08
 Intersection Signal Delay: 49.8
 Intersection LOS: D
 Intersection Capacity Utilization 86.6%
 ICU Level of Service E
 Analysis Period (min) 15
 ~ Volume exceeds capacity, queue is theoretically infinite.
 Queue shown is maximum after two cycles.
 # 95th percentile volume exceeds capacity, queue may be longer.
 Queue shown is maximum after two cycles.
 m Volume for 95th percentile queue is metered by upstream signal.

Splits and Phases: 8: US 64 & SR 1634 (Carolina Village Rd)

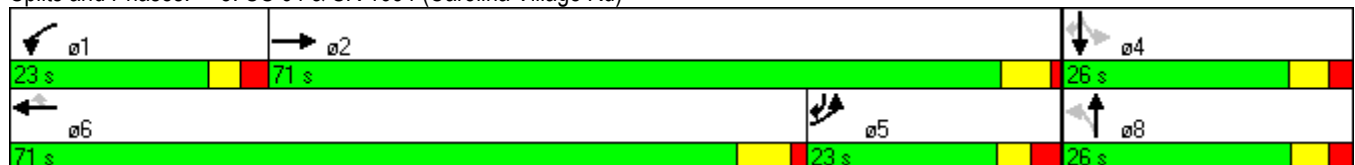

Lanes, Volumes, Timings
9: SR 1783 (Upward Rd) & I-26 NB On-Ramp

2011 Base Year - No Build
Timing Plan: AM Peak



Lane Group	EBL	EBT	EBR	WBL	WBT	WBR	NBL	NBT	NBR	SBL	SBT	SBR
Lane Configurations		↕			↑	↗	↗		↗			
Volume (vph)	329	318	0	0	369	118	212	0	78	0	0	0
Ideal Flow (vphpl)	1900	1900	1900	1900	1900	1900	1900	1900	1900	1900	1900	1900
Storage Length (ft)	0		0	0		50	150		0	0		0
Storage Lanes	0		0	0		1	1		1	0		0
Taper Length (ft)	100		100	100		100	100		100	100		100
Lane Util. Factor	1.00	1.00	1.00	1.00	1.00	1.00	1.00	1.00	1.00	1.00	1.00	1.00
Frt						0.850			0.850			
Flt Protected		0.975					0.950					
Satd. Flow (prot)	0	1763	0	0	1863	1495	1770	0	1583	0	0	0
Flt Permitted		0.620					0.950					
Satd. Flow (perm)	0	1121	0	0	1863	1495	1770	0	1583	0	0	0
Right Turn on Red			No			No			No			No
Satd. Flow (RTOR)												
Link Speed (mph)		45			45			45				45
Link Distance (ft)		630			322			446				658
Travel Time (s)		9.5			4.9			6.8				10.0
Peak Hour Factor	0.90	0.90	0.90	0.90	0.90	0.90	0.90	0.90	0.90	0.90	0.90	0.90
Heavy Vehicles (%)	8%	2%	5%	5%	2%	8%	2%	5%	2%	5%	5%	5%
Adj. Flow (vph)	366	353	0	0	410	131	236	0	87	0	0	0
Shared Lane Traffic (%)												
Lane Group Flow (vph)	0	719	0	0	410	131	236	0	87	0	0	0
Turn Type	Perm					Perm	Prot		custom			
Protected Phases		2			6		8					
Permitted Phases	2					6			8			
Detector Phase	2	2			6	6	8		8			
Switch Phase												
Minimum Initial (s)	12.0	12.0			12.0	12.0	7.0		7.0			
Minimum Split (s)	21.0	21.0			21.0	21.0	14.0		14.0			
Total Split (s)	71.0	71.0	0.0	0.0	71.0	71.0	19.0	0.0	19.0	0.0	0.0	0.0
Total Split (%)	78.9%	78.9%	0.0%	0.0%	78.9%	78.9%	21.1%	0.0%	21.1%	0.0%	0.0%	0.0%
Maximum Green (s)	64.0	64.0			64.0	64.0	12.0		12.0			
Yellow Time (s)	5.0	5.0			5.0	5.0	5.0		5.0			
All-Red Time (s)	2.0	2.0			2.0	2.0	2.0		2.0			
Lost Time Adjust (s)	-2.0	-2.0	-2.0	-2.0	-2.0	-2.0	-2.0	-2.0	-2.0	-2.0	-2.0	-2.0
Total Lost Time (s)	5.0	5.0	2.0	2.0	5.0	5.0	5.0	2.0	5.0	2.0	2.0	2.0
Lead/Lag												
Lead-Lag Optimize?												
Vehicle Extension (s)	3.0	3.0			3.0	3.0	3.0		3.0			
Recall Mode	C-Max	C-Max			C-Max	C-Max	None		None			
Act Effct Green (s)		66.0			66.0	66.0	14.0		14.0			
Actuated g/C Ratio		0.73			0.73	0.73	0.16		0.16			
v/c Ratio		0.87			0.30	0.12	0.86		0.35			
Control Delay		19.3			4.8	3.8	66.5		38.6			
Queue Delay		0.0			0.0	0.0	0.0		0.0			
Total Delay		19.3			4.8	3.8	66.5		38.6			
LOS		B			A	A	E		D			
Approach Delay		19.3			4.5							
Approach LOS		B			A							

Lanes, Volumes, Timings
 9: SR 1783 (Upward Rd) & I-26 NB On-Ramp

2011 Base Year - No Build
 Timing Plan: AM Peak



Lane Group	EBL	EBT	EBR	WBL	WBT	WBR	NBL	NBT	NBR	SBL	SBT	SBR
Queue Length 50th (ft)		314			66	18	132		45			
Queue Length 95th (ft)		#575			100	33	#261		90			
Internal Link Dist (ft)		550			242			366			578	
Turn Bay Length (ft)						50	150					
Base Capacity (vph)		822			1366	1096	275		246			
Starvation Cap Reductn		0			0	0	0		0			
Spillback Cap Reductn		0			0	0	0		0			
Storage Cap Reductn		0			0	0	0		0			
Reduced v/c Ratio		0.87			0.30	0.12	0.86		0.35			

Intersection Summary

Area Type: Other
 Cycle Length: 90
 Actuated Cycle Length: 90
 Offset: 9 (10%), Referenced to phase 2:EBTL and 6:WBT, Start of Green
 Natural Cycle: 90
 Control Type: Actuated-Coordinated
 Maximum v/c Ratio: 0.87
 Intersection Signal Delay: 22.3
 Intersection LOS: C
 Intersection Capacity Utilization 77.8%
 ICU Level of Service D
 Analysis Period (min) 15
 # 95th percentile volume exceeds capacity, queue may be longer.
 Queue shown is maximum after two cycles.

Splits and Phases: 9: SR 1783 (Upward Rd) & I-26 NB On-Ramp



Lanes, Volumes, Timings
 10: SR 1783 (Upward Rd) & I-26 SB Off-Ramp

2011 Base Year - No Build

Timing Plan: AM Peak



Lane Group	EBL	EBT	EBR	WBL	WBT	WBR	NBL	NBT	NBR	SBL	SBT	SBR
Lane Configurations		↑	↗		↖					↘		↗
Volume (vph)	0	553	207	100	481	0	0	0	0	114	0	418
Ideal Flow (vphpl)	1900	1900	1900	1900	1900	1900	1900	1900	1900	1900	1900	1900
Storage Length (ft)	0		200	0		0	0		0	0		100
Storage Lanes	0		1	0		0	0		0	1		1
Taper Length (ft)	100		100	100		100	100		100	100		100
Lane Util. Factor	1.00	1.00	1.00	1.00	1.00	1.00	1.00	1.00	1.00	1.00	1.00	1.00
Fr _t			0.850									0.850
Fl _t Protected					0.991					0.950		
Satd. Flow (prot)	0	1863	1495	0	1827	0	0	0	0	1770	0	1583
Fl _t Permitted					0.656					0.950		
Satd. Flow (perm)	0	1863	1495	0	1210	0	0	0	0	1770	0	1583
Right Turn on Red			No			No			No			No
Satd. Flow (RTOR)												
Link Speed (mph)		45			45			45			45	
Link Distance (ft)		549			630			547			651	
Travel Time (s)		8.3			9.5			8.3			9.9	
Peak Hour Factor	0.90	0.90	0.90	0.90	0.90	0.90	0.90	0.90	0.90	0.90	0.90	0.90
Heavy Vehicles (%)	5%	2%	8%	8%	2%	5%	5%	5%	5%	2%	5%	2%
Adj. Flow (vph)	0	614	230	111	534	0	0	0	0	127	0	464
Shared Lane Traffic (%)												
Lane Group Flow (vph)	0	614	230	0	645	0	0	0	0	127	0	464
Turn Type			Perm	Perm						Prot		custom
Protected Phases		2			6					4		
Permitted Phases			2	6								4
Detector Phase		2	2	6	6					4		4
Switch Phase												
Minimum Initial (s)		12.0	12.0	12.0	12.0					7.0		7.0
Minimum Split (s)		21.0	21.0	21.0	21.0					14.0		14.0
Total Split (s)	0.0	57.0	57.0	57.0	57.0	0.0	0.0	0.0	0.0	33.0	0.0	33.0
Total Split (%)	0.0%	63.3%	63.3%	63.3%	63.3%	0.0%	0.0%	0.0%	0.0%	36.7%	0.0%	36.7%
Maximum Green (s)		50.0	50.0	50.0	50.0					26.0		26.0
Yellow Time (s)		5.0	5.0	5.0	5.0					5.0		5.0
All-Red Time (s)		2.0	2.0	2.0	2.0					2.0		2.0
Lost Time Adjust (s)	-2.0	-2.0	-2.0	-2.0	-2.0	-2.0	-2.0	-2.0	-2.0	-2.0	-2.0	-2.0
Total Lost Time (s)	2.0	5.0	5.0	5.0	5.0	2.0	2.0	2.0	2.0	5.0	2.0	5.0
Lead/Lag												
Lead-Lag Optimize?												
Vehicle Extension (s)		3.0	3.0	3.0	3.0					3.0		3.0
Recall Mode		C-Max	C-Max	C-Max	C-Max					None		None
Act Effct Green (s)		52.0	52.0		52.0					28.0		28.0
Actuated g/C Ratio		0.58	0.58		0.58					0.31		0.31
v/c Ratio		0.57	0.27		0.92					0.23		0.94
Control Delay		14.6	10.5		34.9					24.4		60.8
Queue Delay		0.0	0.0		0.0					0.0		0.0
Total Delay		14.6	10.5		34.9					24.4		60.8
LOS		B	B		C					C		E
Approach Delay		13.5			34.9							
Approach LOS		B			C							

Lanes, Volumes, Timings
 10: SR 1783 (Upward Rd) & I-26 SB Off-Ramp

2011 Base Year - No Build
 Timing Plan: AM Peak



Lane Group	EBL	EBT	EBR	WBL	WBT	WBR	NBL	NBT	NBR	SBL	SBT	SBR
Queue Length 50th (ft)		204	60			360				53		255
Queue Length 95th (ft)		302	101			m#541				98		#446
Internal Link Dist (ft)		469				550		467			571	
Turn Bay Length (ft)			200									100
Base Capacity (vph)		1076	864			699				551		492
Starvation Cap Reductn		0	0			0				0		0
Spillback Cap Reductn		0	0			0				0		0
Storage Cap Reductn		0	0			0				0		0
Reduced v/c Ratio		0.57	0.27			0.92				0.23		0.94

Intersection Summary

Area Type: Other
 Cycle Length: 90
 Actuated Cycle Length: 90
 Offset: 0 (0%), Referenced to phase 2:EBT and 6:WBTL, Start of Green
 Natural Cycle: 80
 Control Type: Actuated-Coordinated
 Maximum v/c Ratio: 0.94
 Intersection Signal Delay: 31.4
 Intersection LOS: C
 Intersection Capacity Utilization 77.9%
 ICU Level of Service D
 Analysis Period (min) 15
 # 95th percentile volume exceeds capacity, queue may be longer.
 Queue shown is maximum after two cycles.
 m Volume for 95th percentile queue is metered by upstream signal.

Splits and Phases: 10: SR 1783 (Upward Rd) & I-26 SB Off-Ramp

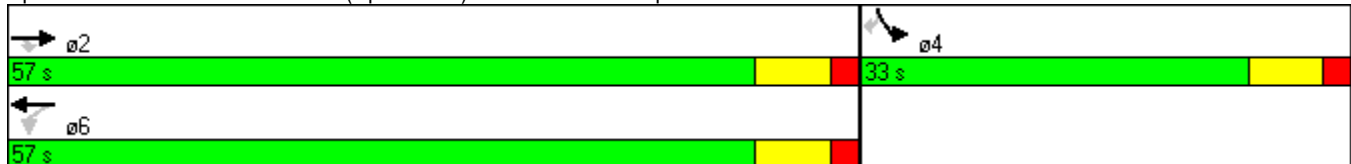

Lanes, Volumes, Timings
 1: NC 146 (Long Shoals Rd) & I-26 NB On-Ramp

2011 Base Year - No Build

Timing Plan: PM Peak

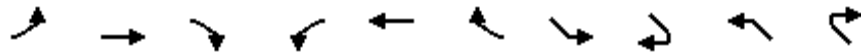

Lane Group	EBL	EBT	EBR2	WBL	WBT	WBR2	SEL	SER2	NWL	NWR2
Lane Configurations	↗↘	↑↑	↗	↗↘	↑↑	↗	↗↘	↗	↗↘	↗
Volume (vph)	179	618	181	379	466	637	663	141	178	495
Ideal Flow (vphpl)	1900	1900	1900	1900	1900	1900	1900	1900	1900	1900
Grade (%)		3%			-7%					
Storage Length (ft)	450			350			0		675	
Storage Lanes	1			2			2		1	
Taper Length (ft)	100			100			100		100	
Lane Util. Factor	0.97	0.95	1.00	0.97	0.95	1.00	0.97	1.00	0.97	1.00
Frt			0.850			0.850		0.850		0.850
Flt Protected	0.950			0.950			0.950		0.950	
Satd. Flow (prot)	3224	3452	1487	3387	3663	1562	3519	1607	3434	1599
Flt Permitted	0.950			0.950			0.950		0.950	
Satd. Flow (perm)	3224	3452	1487	3387	3663	1562	3519	1607	3434	1599
Right Turn on Red			No			No		No		No
Satd. Flow (RTOR)										
Link Speed (mph)		45			45					
Link Distance (ft)		1009			964					
Travel Time (s)		15.3			14.6					
Peak Hour Factor	0.90	0.90	0.90	0.90	0.90	0.90	0.90	0.90	0.90	0.90
Heavy Vehicles (%)	7%	3%	7%	7%	2%	7%	2%	3%	3%	2%
Adj. Flow (vph)	199	687	201	421	518	708	737	157	198	550
Shared Lane Traffic (%)										
Lane Group Flow (vph)	199	687	201	421	518	708	737	157	198	550
Turn Type	Prot		Free	Prot		Free	Prot	custom	Prot	Free
Protected Phases	5	2		1	6		4		8	
Permitted Phases			Free			Free		4		Free
Detector Phase	5	2		1	6		4	4	8	
Switch Phase										
Minimum Initial (s)	7.0	12.0		7.0	12.0		7.0	7.0	7.0	
Minimum Split (s)	15.2	19.5		14.7	21.0		15.1	15.1	15.0	
Total Split (s)	25.0	35.0	0.0	25.0	35.0	0.0	40.0	40.0	40.0	0.0
Total Split (%)	25.0%	35.0%	0.0%	25.0%	35.0%	0.0%	40.0%	40.0%	40.0%	0.0%
Maximum Green (s)	16.8	27.5		17.3	26.0		31.9	31.9	32.0	
Yellow Time (s)	3.4	4.3		4.0	5.2		3.8	3.8	3.7	
All-Red Time (s)	4.8	3.2		3.7	3.8		4.3	4.3	4.3	
Lost Time Adjust (s)	-3.2	-2.5	-2.5	-2.7	-4.0	-4.0	-3.1	-3.1	-3.0	0.0
Total Lost Time (s)	5.0	5.0	1.5	5.0	5.0	0.0	5.0	5.0	5.0	4.0
Lead/Lag	Lead	Lag		Lead	Lag					
Lead-Lag Optimize?	Yes	Yes		Yes	Yes					
Vehicle Extension (s)	2.0	6.0		2.0	6.0		2.0	2.0	2.0	
Minimum Gap (s)	3.0	3.0		3.0	3.0		3.0	3.0	3.0	
Time Before Reduce (s)	0.0	15.0		0.0	15.0		0.0	0.0	0.0	
Time To Reduce (s)	0.0	30.0		0.0	30.0		0.0	0.0	0.0	
Recall Mode	None	C-Max		None	C-Max		None	None	None	
Act Effct Green (s)	13.7	37.6	100.0	18.6	42.5	100.0	28.8	28.8	28.8	100.0
Actuated g/C Ratio	0.14	0.38	1.00	0.19	0.42	1.00	0.29	0.29	0.29	1.00
v/c Ratio	0.45	0.53	0.14	0.67	0.33	0.45	0.73	0.34	0.20	0.34
Control Delay	42.5	27.6	0.2	43.2	21.4	1.0	36.3	29.3	26.4	0.6
Queue Delay	0.0	0.0	0.0	0.0	0.0	0.0	0.0	0.0	0.0	0.0

Lanes, Volumes, Timings
 1: NC 146 (Long Shoals Rd) & I-26 NB On-Ramp

2011 Base Year - No Build
 Timing Plan: PM Peak

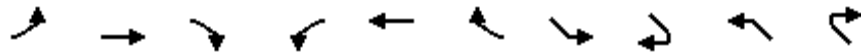

Lane Group	EBL	EBT	EBR2	WBL	WBT	WBR2	SEL	SER2	NWL	NWR2
Total Delay	42.5	27.6	0.2	43.2	21.4	1.0	36.3	29.3	26.4	0.6
LOS	D	C	A	D	C	A	D	C	C	A
Approach Delay	25.2			18.2						
Approach LOS	C			B						
Queue Length 50th (ft)	60	178	0	128	113	0	218	79	48	0
Queue Length 95th (ft)	92	264	0	177	182	0	258	124	70	0
Internal Link Dist (ft)	929			884						
Turn Bay Length (ft)	450		300	350		300		425	675	575
Base Capacity (vph)	645	1298	1487	687	1557	1562	1232	562	1202	1599
Starvation Cap Reductn	0	0	0	0	0	0	0	0	0	0
Spillback Cap Reductn	0	0	0	0	0	0	0	0	0	0
Storage Cap Reductn	0	0	0	0	0	0	0	0	0	0
Reduced v/c Ratio	0.31	0.53	0.14	0.61	0.33	0.45	0.60	0.28	0.16	0.34

Intersection Summary

Area Type: Other
 Cycle Length: 100
 Actuated Cycle Length: 100
 Offset: 9 (9%), Referenced to phase 2:EBT and 6:WBT, Start of Green
 Natural Cycle: 55
 Control Type: Actuated-Coordinated
 Maximum v/c Ratio: 0.73
 Intersection Signal Delay: 21.5
 Intersection LOS: C
 Intersection Capacity Utilization 59.3%
 ICU Level of Service B
 Analysis Period (min) 15

Splits and Phases: 1: NC 146 (Long Shoals Rd) & I-26 NB On-Ramp

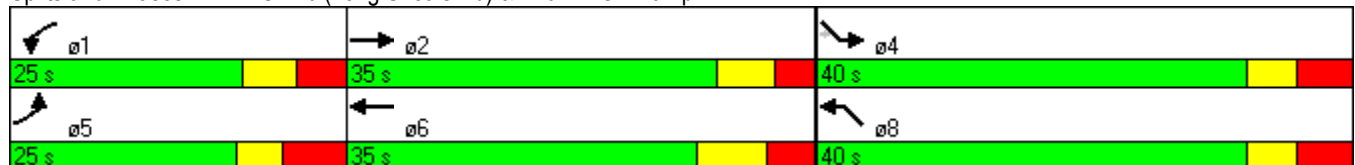

Lanes, Volumes, Timings
2: I-26 NB On-Ramp & US 25 (Asheville Highway)

2011 Base Year - No Build
Timing Plan: PM Peak



Lane Group	EBL	EBT	EBR	WBL	WBT	WBR	NBL	NBT	NBR	SBL	SBT	SBR
Lane Configurations				↙		↗	↗	↗	↗		↗	↗
Volume (vph)	0	0	0	123	0	401	576	1036	0	0	990	190
Ideal Flow (vphpl)	1900	1900	1900	1900	1900	1900	1900	1900	1900	1900	1900	1900
Grade (%)		0%			2%			-1%			2%	
Storage Length (ft)	0		0	0		150	0		0	0		300
Storage Lanes	0		0	1		2	1		0	0		1
Taper Length (ft)	100		100	100		100	100		100	100		100
Lane Util. Factor	1.00	1.00	1.00	1.00	1.00	0.88	1.00	0.95	1.00	1.00	0.95	1.00
Frt						0.850						0.850
Flt Protected				0.950			0.950					
Satd. Flow (prot)	0	0	0	1735	0	2706	1680	3489	0	0	3436	1480
Flt Permitted				0.950			0.950					
Satd. Flow (perm)	0	0	0	1735	0	2706	1680	3489	0	0	3436	1480
Right Turn on Red			No			No			No			No
Satd. Flow (RTOR)												
Link Speed (mph)		45			35			45			45	
Link Distance (ft)		533			612			601			596	
Travel Time (s)		8.1			11.9			9.1			9.0	
Peak Hour Factor	0.90	0.90	0.90	0.90	0.90	0.90	0.90	0.90	0.90	0.90	0.90	0.90
Heavy Vehicles (%)	5%	5%	5%	3%	5%	4%	8%	4%	5%	5%	4%	8%
Adj. Flow (vph)	0	0	0	137	0	446	640	1151	0	0	1100	211
Shared Lane Traffic (%)												
Lane Group Flow (vph)	0	0	0	137	0	446	640	1151	0	0	1100	211
Turn Type				Prot		custom	Prot					Free
Protected Phases				4			5	2			6	
Permitted Phases						4						Free
Detector Phase				4		4	5	2			6	
Switch Phase												
Minimum Initial (s)				7.0		7.0	7.0	12.0			12.0	
Minimum Split (s)				13.0		13.0	14.0	19.0			18.0	
Total Split (s)	0.0	0.0	0.0	20.0	0.0	20.0	40.0	110.0	0.0	0.0	70.0	0.0
Total Split (%)	0.0%	0.0%	0.0%	15.4%	0.0%	15.4%	30.8%	84.6%	0.0%	0.0%	53.8%	0.0%
Maximum Green (s)				14.0		14.0	33.6	103.9			64.7	
Yellow Time (s)				3.7		3.7	3.0	4.6			4.3	
All-Red Time (s)				2.3		2.3	3.4	1.5			1.0	
Lost Time Adjust (s)	0.0	0.0	-2.0	-2.0	0.0	-2.0	-1.4	-1.1	0.0	-2.0	-0.3	0.0
Total Lost Time (s)	4.0	4.0	2.0	4.0	4.0	4.0	5.0	5.0	4.0	2.0	5.0	4.0
Lead/Lag							Lag				Lead	
Lead-Lag Optimize?							Yes				Yes	
Vehicle Extension (s)				2.0		2.0	2.0	8.0			8.0	
Minimum Gap (s)				3.0		3.0	3.0	5.5			5.5	
Time Before Reduce (s)				0.0		0.0	0.0	15.0			15.0	
Time To Reduce (s)				0.0		0.0	0.0	50.0			50.0	
Recall Mode				None		None	None	C-Max			C-Max	
Act Effct Green (s)				16.0		16.0	35.0	105.0			65.0	130.0
Actuated g/C Ratio				0.12		0.12	0.27	0.81			0.50	1.00
v/c Ratio				0.64		1.34	1.42	0.41			0.64	0.14
Control Delay				68.8		214.7	232.9	1.8			26.1	0.2
Queue Delay				0.0		0.0	0.0	0.9			0.0	0.0

Lanes, Volumes, Timings
 2: I-26 NB On-Ramp & US 25 (Asheville Highway)

2011 Base Year - No Build
 Timing Plan: PM Peak



Lane Group	EBL	EBT	EBR	WBL	WBT	WBR	NBL	NBT	NBR	SBL	SBT	SBR
Total Delay				68.8		214.7	232.9	2.7			26.1	0.2
LOS				E		F	F	A			C	A
Approach Delay								85.0			21.9	
Approach LOS								F			C	
Queue Length 50th (ft)				112		~277	~747	64			348	0
Queue Length 95th (ft)				#184		#397	m#794	m63			422	0
Internal Link Dist (ft)		453			532			521			516	
Turn Bay Length (ft)						150						300
Base Capacity (vph)				214		333	452	2818			1718	1480
Starvation Cap Reductn				0		0	0	1285			0	0
Spillback Cap Reductn				0		0	0	0			0	0
Storage Cap Reductn				0		0	0	0			0	0
Reduced v/c Ratio				0.64		1.34	1.42	0.75			0.64	0.14

Intersection Summary

Area Type: Other
 Cycle Length: 130
 Actuated Cycle Length: 130
 Offset: 95 (73%), Referenced to phase 2:NBT and 6:SBT, Start of Green
 Natural Cycle: 100
 Control Type: Actuated-Coordinated
 Maximum v/c Ratio: 1.42
 Intersection Signal Delay: 77.6
 Intersection LOS: E
 Intersection Capacity Utilization 80.1%
 ICU Level of Service D
 Analysis Period (min) 15
 ~ Volume exceeds capacity, queue is theoretically infinite.
 Queue shown is maximum after two cycles.
 # 95th percentile volume exceeds capacity, queue may be longer.
 Queue shown is maximum after two cycles.
 m Volume for 95th percentile queue is metered by upstream signal.

Splits and Phases: 2: I-26 NB On-Ramp & US 25 (Asheville Highway)

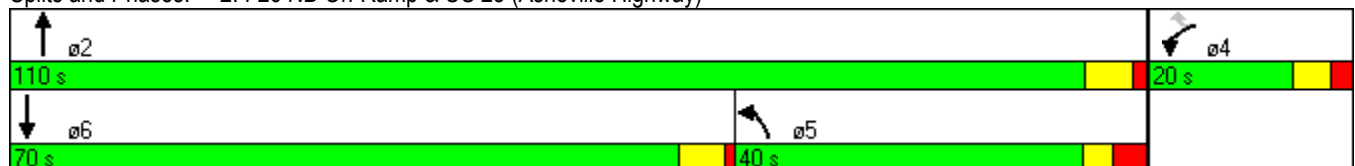

Lanes, Volumes, Timings
 3: I-26 SB Off-Ramp & US 25 (Asheville Highway)

2011 Base Year - No Build

Timing Plan: PM Peak



Lane Group	EBL	EBT	EBR	WBL	WBT	WBR	NBL	NBT	NBR	SBL	SBT	SBR
Lane Configurations												
Volume (vph)	193	0	465	0	0	0	0	1419	123	320	793	0
Ideal Flow (vphpl)	1900	1900	1900	1900	1900	1900	1900	1900	1900	1900	1900	1900
Grade (%)		3%			0%			4%			1%	
Storage Length (ft)	0		100	0		0	0		500	0		0
Storage Lanes	1		1	0		0	0		1	1		0
Taper Length (ft)	100		100	100		100	100		100	100		100
Lane Util. Factor	1.00	1.00	1.00	1.00	1.00	1.00	1.00	0.95	1.00	1.00	0.95	1.00
Frt			0.850						0.850			
Flt Protected	0.950									0.950		
Satd. Flow (prot)	1710	0	1544	0	0	0	0	3435	1465	1663	3487	0
Flt Permitted	0.950									0.950		
Satd. Flow (perm)	1710	0	1544	0	0	0	0	3435	1465	1663	3487	0
Right Turn on Red			Yes			No			No			No
Satd. Flow (RTOR)			253									
Link Speed (mph)		35			45			45			45	
Link Distance (ft)		471			598			795			601	
Travel Time (s)		9.2			9.1			12.0			9.1	
Peak Hour Factor	0.90	0.90	0.90	0.90	0.90	0.90	0.90	0.90	0.90	0.90	0.90	0.90
Heavy Vehicles (%)	4%	5%	3%	5%	5%	5%	5%	3%	8%	8%	3%	5%
Adj. Flow (vph)	214	0	517	0	0	0	0	1577	137	356	881	0
Shared Lane Traffic (%)												
Lane Group Flow (vph)	214	0	517	0	0	0	0	1577	137	356	881	0
Turn Type	Prot		custom						Free	Prot		
Protected Phases	4		4					2		1	6	
Permitted Phases									Free			
Detector Phase	4		4					2		1	6	
Switch Phase												
Minimum Initial (s)	7.0		7.0					12.0		7.0	12.0	
Minimum Split (s)	14.0		14.0					19.0		14.0	19.0	
Total Split (s)	24.0	0.0	24.0	0.0	0.0	0.0	0.0	66.0	0.0	40.0	106.0	0.0
Total Split (%)	18.5%	0.0%	18.5%	0.0%	0.0%	0.0%	0.0%	50.8%	0.0%	30.8%	81.5%	0.0%
Maximum Green (s)	18.0		18.0					60.3		33.5	100.3	
Yellow Time (s)	4.0		4.0					4.7		4.0	4.7	
All-Red Time (s)	2.0		2.0					1.0		2.5	1.0	
Lost Time Adjust (s)	-1.0	-2.0	-1.0	-2.0	-2.0	-2.0	-2.0	-0.7	-0.7	-1.5	-1.7	-2.0
Total Lost Time (s)	5.0	2.0	5.0	2.0	2.0	2.0	2.0	5.0	3.3	5.0	4.0	2.0
Lead/Lag								Lead		Lag		
Lead-Lag Optimize?								Yes		Yes		
Vehicle Extension (s)	2.0		2.0					8.0		2.0	8.0	
Minimum Gap (s)	3.0		3.0					5.5		3.0	5.5	
Time Before Reduce (s)	0.0		0.0					15.0		0.0	15.0	
Time To Reduce (s)	0.0		0.0					50.0		0.0	50.0	
Recall Mode	None		None					C-Max		None	C-Max	
Act Effct Green (s)	19.0		19.0					61.0	130.0	35.0	102.0	
Actuated g/C Ratio	0.15		0.15					0.47	1.00	0.27	0.78	
v/c Ratio	0.86		1.17					0.98	0.09	0.79	0.32	
Control Delay	84.0		123.0					51.9	0.1	58.1	0.6	
Queue Delay	0.0		0.0					0.0	0.0	0.0	0.2	

Lanes, Volumes, Timings
 3: I-26 SB Off-Ramp & US 25 (Asheville Highway)

2011 Base Year - No Build
 Timing Plan: PM Peak

Lane Group	EBL	EBT	EBR	WBL	WBT	WBR	NBL	NBT	NBR	SBL	SBT	SBR
Total Delay	84.0		123.0					51.9	0.1	58.1	0.8	
LOS	F		F					D	A	E	A	
Approach Delay								47.8			17.3	
Approach LOS								D			B	
Queue Length 50th (ft)	178		~326					671	0	322	6	
Queue Length 95th (ft)	#319		#550					#850	0	#439	4	
Internal Link Dist (ft)		391			518			715			521	
Turn Bay Length (ft)			100						500			
Base Capacity (vph)	250		442					1612	1465	448	2736	
Starvation Cap Reductn	0		0					0	0	0	930	
Spillback Cap Reductn	0		0					0	0	0	0	
Storage Cap Reductn	0		0					0	0	0	0	
Reduced v/c Ratio	0.86		1.17					0.98	0.09	0.79	0.49	

Intersection Summary

Area Type: Other
 Cycle Length: 130
 Actuated Cycle Length: 130
 Offset: 91 (70%), Referenced to phase 2:NBT and 6:SBT, Start of Green
 Natural Cycle: 110
 Control Type: Actuated-Coordinated
 Maximum v/c Ratio: 1.17
 Intersection Signal Delay: 50.2
 Intersection LOS: D
 Intersection Capacity Utilization 80.1%
 ICU Level of Service D
 Analysis Period (min) 15
 ~ Volume exceeds capacity, queue is theoretically infinite.
 Queue shown is maximum after two cycles.
 # 95th percentile volume exceeds capacity, queue may be longer.
 Queue shown is maximum after two cycles.

Splits and Phases: 3: I-26 SB Off-Ramp & US 25 (Asheville Highway)

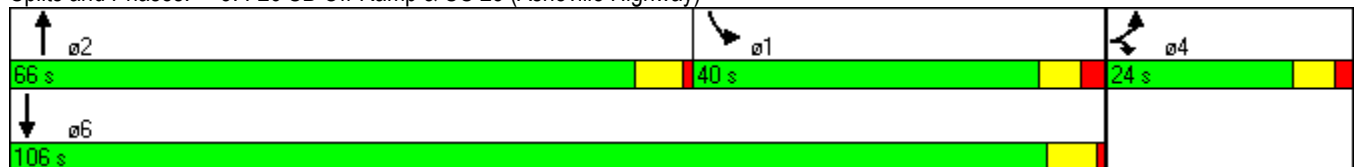

Lanes, Volumes, Timings
6: US 64 & SR 1516 (Francis Rd)

2011 Base Year - No Build
Timing Plan: PM Peak



Lane Group	EBL	EBT	EBR	WBL	WBT	WBR	NBL	NBT	NBR	SBL	SBT	SBR
Lane Configurations												
Volume (vph)	103	1863	333	62	1470	19	375	5	88	27	5	117
Ideal Flow (vphpl)	1900	1900	1900	1900	1900	1900	1900	1900	1900	1900	1900	1900
Grade (%)		-1%			4%			-1%			2%	
Storage Length (ft)	150		0	125		0	150		150	0		150
Storage Lanes	1		1	1		0	1		1	0		1
Taper Length (ft)	100		100	100		100	100		100	100		100
Lane Util. Factor	1.00	0.95	1.00	1.00	0.95	0.95	0.95	0.95	1.00	1.00	1.00	1.00
Frt			0.850		0.998				0.850			0.850
Flt Protected	0.950			0.950			0.950	0.954			0.960	
Satd. Flow (prot)	1778	3557	1591	1734	3461	0	1690	1697	1591	0	1770	1567
Flt Permitted	0.950			0.950			0.950	0.954			0.960	
Satd. Flow (perm)	1778	3557	1591	1734	3461	0	1690	1697	1591	0	1770	1567
Right Turn on Red			No			No			No			No
Satd. Flow (RTOR)												
Link Speed (mph)		45			45			35			35	
Link Distance (ft)		836			622			375			406	
Travel Time (s)		12.7			9.4			7.3			7.9	
Peak Hour Factor	0.90	0.90	0.90	0.90	0.90	0.90	0.90	0.90	0.90	0.90	0.90	0.90
Heavy Vehicles (%)	2%	2%	2%	2%	2%	2%	2%	2%	2%	2%	2%	2%
Adj. Flow (vph)	114	2070	370	69	1633	21	417	6	98	30	6	130
Shared Lane Traffic (%)							49%					
Lane Group Flow (vph)	114	2070	370	69	1654	0	213	210	98	0	36	130
Turn Type	Prot		Perm	Prot			Split		pm+ov	Split		pm+ov
Protected Phases	5	2		1	6		4	4	1	3	3	5
Permitted Phases			2						4			3
Detector Phase	5	2	2	1	6		4	4	1	3	3	5
Switch Phase												
Minimum Initial (s)	7.0	12.0	12.0	7.0	12.0		7.0	7.0	7.0	7.0	7.0	7.0
Minimum Split (s)	13.0	18.0	18.0	13.0	18.0		14.0	14.0	13.0	14.0	14.0	13.0
Total Split (s)	20.0	80.0	80.0	20.0	80.0	0.0	30.0	30.0	20.0	30.0	30.0	20.0
Total Split (%)	12.5%	50.0%	50.0%	12.5%	50.0%	0.0%	18.8%	18.8%	12.5%	18.8%	18.8%	12.5%
Maximum Green (s)	14.4	74.0	74.0	14.6	74.4		23.4	23.4	14.6	23.5	23.5	14.4
Yellow Time (s)	3.2	4.6	4.6	3.0	4.2		3.9	3.9	3.0	3.7	3.7	3.2
All-Red Time (s)	2.4	1.4	1.4	2.4	1.4		2.7	2.7	2.4	2.8	2.8	2.4
Lost Time Adjust (s)	-0.6	-1.0	-1.0	-0.4	-0.6	-2.0	-1.6	-1.6	-0.4	-2.0	-1.5	-0.6
Total Lost Time (s)	5.0	5.0	5.0	5.0	5.0	2.0	5.0	5.0	5.0	4.5	5.0	5.0
Lead/Lag	Lead	Lag	Lag	Lead	Lag		Lag	Lag	Lead	Lead	Lead	Lead
Lead-Lag Optimize?	Yes	Yes	Yes	Yes	Yes		Yes	Yes	Yes	Yes	Yes	Yes
Vehicle Extension (s)	1.0	2.0	2.0	1.0	2.0		1.0	1.0	1.0	1.0	1.0	1.0
Recall Mode	None	C-Max	C-Max	None	C-Max		None	None	None	None	None	None
Act Effct Green (s)	14.8	97.1	97.1	10.6	92.9		25.7	25.7	41.3		9.3	22.4
Actuated g/C Ratio	0.09	0.61	0.61	0.07	0.58		0.16	0.16	0.26		0.06	0.14
v/c Ratio	0.70	0.96	0.38	0.60	0.82		0.78	0.77	0.24		0.35	0.59
Control Delay	98.1	37.0	13.2	93.4	33.6		83.6	82.1	46.2		81.7	52.9
Queue Delay	0.0	0.0	0.0	0.0	0.0		0.0	0.0	0.0		0.0	0.0
Total Delay	98.1	37.0	13.2	93.4	33.6		83.6	82.1	46.2		81.7	52.9
LOS	F	D	B	F	C		F	F	D		F	D
Approach Delay		36.3			36.0			76.0			59.2	

Lanes, Volumes, Timings
6: US 64 & SR 1516 (Francis Rd)

2011 Base Year - No Build
Timing Plan: PM Peak



Lane Group	EBL	EBT	EBR	WBL	WBT	WBR	NBL	NBT	NBR	SBL	SBT	SBR
Approach LOS	D			D			E			E		
Queue Length 50th (ft)	116	1126	158	72	730		228	224	82		37	94
Queue Length 95th (ft)	178	#1484	293	126	#1094		314	310	123		78	124
Internal Link Dist (ft)	756			542			295			326		
Turn Bay Length (ft)	150			125			150			150		
Base Capacity (vph)	183	2159	965	163	2009		292	294	455		277	235
Starvation Cap Reductn	0	0	0	0	0		0	0	0		0	0
Spillback Cap Reductn	0	0	0	0	0		0	0	0		0	0
Storage Cap Reductn	0	0	0	0	0		0	0	0		0	0
Reduced v/c Ratio	0.62	0.96	0.38	0.42	0.82		0.73	0.71	0.22		0.13	0.55

Intersection Summary

Area Type: Other
 Cycle Length: 160
 Actuated Cycle Length: 160
 Offset: 144 (90%), Referenced to phase 2:EBT and 6:WBT, Start of Green
 Natural Cycle: 120
 Control Type: Actuated-Coordinated
 Maximum v/c Ratio: 0.96
 Intersection Signal Delay: 41.1
 Intersection LOS: D
 Intersection Capacity Utilization 87.0%
 ICU Level of Service E
 Analysis Period (min) 15
 # 95th percentile volume exceeds capacity, queue may be longer.
 Queue shown is maximum after two cycles.

Splits and Phases: 6: US 64 & SR 1516 (Francis Rd)



Lanes, Volumes, Timings
7: US 64 & I-26 SB Off-Ramp

2011 Base Year - No Build

Timing Plan: PM Peak

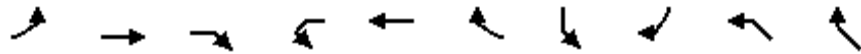

Lane Group	EBL	EBT	EBR	WBL	WBT	WBR	SBL	SBR	NWL	NWR
Lane Configurations		↑↑	↑		↑↑			↑↑		
Volume (vph)	0	1835	254	0	1399	0	0	294	0	0
Ideal Flow (vphpl)	1900	1900	1900	1900	1900	1900	1900	1900	1900	1900
Grade (%)		3%			-3%		-3%		0%	
Storage Length (ft)	0		0	0		0	0	500	0	0
Storage Lanes	0		1	0		0	0	1	0	0
Taper Length (ft)	100		100	100		100	100	100	100	100
Lane Util. Factor	1.00	0.95	1.00	1.00	0.95	1.00	1.00	0.88	1.00	1.00
Frt			0.850					0.850		
Flt Protected										
Satd. Flow (prot)	0	3486	1473	0	3592	0	0	2828	0	0
Flt Permitted										
Satd. Flow (perm)	0	3486	1473	0	3592	0	0	2828	0	0
Right Turn on Red			No			No		No		
Satd. Flow (RTOR)										
Link Speed (mph)		45			45		35		45	
Link Distance (ft)		728			745		807		350	
Travel Time (s)		11.0			11.3		15.7		5.3	
Peak Hour Factor	0.90	0.90	0.90	0.90	0.90	0.90	0.90	0.90	0.90	0.90
Heavy Vehicles (%)	5%	2%	8%	5%	2%	5%	5%	2%	5%	5%
Adj. Flow (vph)	0	2039	282	0	1554	0	0	327	0	0
Shared Lane Traffic (%)										
Lane Group Flow (vph)	0	2039	282	0	1554	0	0	327	0	0
Turn Type			Perm					custom		
Protected Phases		Free			6			4		
Permitted Phases			Free							
Detector Phase					6			4		
Switch Phase										
Minimum Initial (s)					12.0			7.0		
Minimum Split (s)					18.0			13.0		
Total Split (s)	0.0	0.0	0.0	0.0	120.0	0.0	0.0	40.0	0.0	0.0
Total Split (%)	0.0%	0.0%	0.0%	0.0%	75.0%	0.0%	0.0%	25.0%	0.0%	0.0%
Maximum Green (s)					114.2			34.9		
Yellow Time (s)					4.8			4.1		
All-Red Time (s)					1.0			1.0		
Lost Time Adjust (s)	0.0	0.0	0.0	0.0	-0.8	0.0	0.0	-0.1	-2.0	0.0
Total Lost Time (s)	4.0	4.0	4.0	4.0	5.0	4.0	4.0	5.0	2.0	4.0
Lead/Lag										
Lead-Lag Optimize?										
Vehicle Extension (s)					2.0			1.0		
Recall Mode					C-Max			None		
Act Effct Green (s)		160.0	160.0		127.8			22.2		
Actuated g/C Ratio		1.00	1.00		0.80			0.14		
v/c Ratio		0.58	0.19		0.54			0.83		
Control Delay		1.1	0.1		5.1			85.2		
Queue Delay		0.0	0.0		0.1			0.0		
Total Delay		1.1	0.1		5.2			85.2		
LOS		A	A		A			F		
Approach Delay		1.0			5.2					

Lanes, Volumes, Timings
7: US 64 & I-26 SB Off-Ramp

2011 Base Year - No Build

Timing Plan: PM Peak

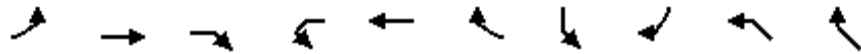

Lane Group	EBL	EBT	EBR	WBL	WBT	WBR	SBL	SBR	NWL	NWR
Approach LOS		A			A					
Queue Length 50th (ft)		0	0		196			192		
Queue Length 95th (ft)		m0	m0		218			245		
Internal Link Dist (ft)		648			665		727		270	
Turn Bay Length (ft)								500		
Base Capacity (vph)		3486	1473		2870			619		
Starvation Cap Reductn		0	0		0			0		
Spillback Cap Reductn		0	0		287			0		
Storage Cap Reductn		0	0		0			0		
Reduced v/c Ratio		0.58	0.19		0.60			0.53		

Intersection Summary

Area Type: Other
 Cycle Length: 160
 Actuated Cycle Length: 160
 Offset: 0 (0%), Referenced to phase 6:WBT, Start of Green, Master Intersection
 Natural Cycle: 40
 Control Type: Actuated-Coordinated
 Maximum v/c Ratio: 0.83
 Intersection Signal Delay: 9.1
 Intersection LOS: A
 Intersection Capacity Utilization 86.2%
 ICU Level of Service E
 Analysis Period (min) 15
 m Volume for 95th percentile queue is metered by upstream signal.

Splits and Phases: 7: US 64 & I-26 SB Off-Ramp



Lanes, Volumes, Timings
8: US 64 & SR 1634 (Carolina Village Rd)

2011 Base Year - No Build
Timing Plan: PM Peak



Lane Group	EBL	EBT	EBR	WBL	WBT	WBR	NBL	NBT	NBR	SBL	SBT	SBR
Lane Configurations												
Volume (vph)	79	1829	66	107	1481	117	69	22	139	106	15	58
Ideal Flow (vphpl)	1900	1900	1900	1900	1900	1900	1900	1900	1900	1900	1900	1900
Grade (%)		1%			-3%			3%				-1%
Storage Length (ft)	100		0	100		0	0		0	0		150
Storage Lanes	1		0	1		1	0		0	0		1
Taper Length (ft)	100		100	100		100	100		100	100		100
Lane Util. Factor	1.00	0.95	0.95	1.00	0.95	1.00	1.00	1.00	1.00	1.00	1.00	1.00
Frt		0.995				0.850		0.918				0.850
Flt Protected	0.950			0.950				0.985			0.958	
Satd. Flow (prot)	1761	3504	0	1796	3592	1607	0	1659	0	0	1793	1591
Flt Permitted	0.950			0.950				0.727			0.450	
Satd. Flow (perm)	1761	3504	0	1796	3592	1607	0	1225	0	0	842	1591
Right Turn on Red			No			No			No			No
Satd. Flow (RTOR)												
Link Speed (mph)		45			45			30			30	
Link Distance (ft)		560			728			219			359	
Travel Time (s)		8.5			11.0			5.0			8.2	
Peak Hour Factor	0.90	0.90	0.90	0.90	0.90	0.90	0.90	0.90	0.90	0.90	0.90	0.90
Heavy Vehicles (%)	2%	2%	2%	2%	2%	2%	2%	2%	2%	2%	2%	2%
Adj. Flow (vph)	88	2032	73	119	1646	130	77	24	154	118	17	64
Shared Lane Traffic (%)												
Lane Group Flow (vph)	88	2105	0	119	1646	130	0	255	0	0	135	64
Turn Type	Prot			Prot		Perm	Perm			Perm		pm+ov
Protected Phases	5	2		1	6			8			4	5
Permitted Phases						6	8			4		4
Detector Phase	5	2		1	6	6	8	8		4	4	5
Switch Phase												
Minimum Initial (s)	7.0	12.0		7.0	12.0	12.0	7.0	7.0		7.0	7.0	7.0
Minimum Split (s)	13.0	18.0		13.0	19.0	19.0	13.0	13.0		13.0	13.0	13.0
Total Split (s)	20.0	90.0	0.0	20.0	90.0	90.0	50.0	50.0	0.0	50.0	50.0	20.0
Total Split (%)	12.5%	56.3%	0.0%	12.5%	56.3%	56.3%	31.3%	31.3%	0.0%	31.3%	31.3%	12.5%
Maximum Green (s)	14.1	84.4		14.6	83.8	83.8	44.2	44.2		44.1	44.1	14.1
Yellow Time (s)	3.0	4.4		3.0	4.8	4.8	3.4	3.4		3.6	3.6	3.0
All-Red Time (s)	2.9	1.2		2.4	1.4	1.4	2.4	2.4		2.3	2.3	2.9
Lost Time Adjust (s)	-0.9	-0.6	-2.0	-0.4	-1.2	-1.2	-2.0	-0.8	-2.0	-2.0	-0.9	-0.9
Total Lost Time (s)	5.0	5.0	2.0	5.0	5.0	5.0	3.8	5.0	2.0	3.9	5.0	5.0
Lead/Lag	Lag	Lag		Lead	Lead	Lead						Lag
Lead-Lag Optimize?	Yes	Yes		Yes	Yes	Yes						Yes
Vehicle Extension (s)	1.0	2.0		1.0	2.0	2.0	1.0	1.0		1.0	1.0	1.0
Recall Mode	None	C-Max		None	C-Max	C-Max	None	None		None	None	None
Act Effct Green (s)	15.0	97.0		13.6	95.6	95.6		34.4			34.4	54.4
Actuated g/C Ratio	0.09	0.61		0.08	0.60	0.60		0.22			0.22	0.34
v/c Ratio	0.53	0.99		0.78	0.77	0.14		0.97			0.75	0.12
Control Delay	81.7	48.7		97.7	30.7	15.2		109.4			81.9	34.6
Queue Delay	0.0	0.0		0.0	0.3	0.0		0.0			0.0	0.0
Total Delay	81.7	48.7		97.7	31.1	15.2		109.4			81.9	34.6
LOS	F	D		F	C	B		F			F	C
Approach Delay		50.0			34.2			109.4			66.7	

Lanes, Volumes, Timings
 8: US 64 & SR 1634 (Carolina Village Rd)

2011 Base Year - No Build
 Timing Plan: PM Peak



Lane Group	EBL	EBT	EBR	WBL	WBT	WBR	NBL	NBT	NBR	SBL	SBT	SBR
Approach LOS	D			C			F			E		
Queue Length 50th (ft)	90	~1142		121	828	61	267			133	46	
Queue Length 95th (ft)	153	#1467		#215	945	92	359			203	75	
Internal Link Dist (ft)	480			648			139			279		
Turn Bay Length (ft)	100			100						150		
Base Capacity (vph)	165	2125		173	2147	961	345			237	541	
Starvation Cap Reductn	0	0		0	121	0	0			0	0	
Spillback Cap Reductn	0	0		0	0	0	0			0	0	
Storage Cap Reductn	0	0		0	0	0	0			0	0	
Reduced v/c Ratio	0.53	0.99		0.69	0.81	0.14	0.74			0.57	0.12	

Intersection Summary

Area Type: Other
 Cycle Length: 160
 Actuated Cycle Length: 160
 Offset: 57 (36%), Referenced to phase 2:EBT and 6:WBT, Start of Green
 Natural Cycle: 110
 Control Type: Actuated-Coordinated
 Maximum v/c Ratio: 0.99
 Intersection Signal Delay: 47.5
 Intersection LOS: D
 Intersection Capacity Utilization 91.3%
 ICU Level of Service F
 Analysis Period (min) 15
 ~ Volume exceeds capacity, queue is theoretically infinite.
 Queue shown is maximum after two cycles.
 # 95th percentile volume exceeds capacity, queue may be longer.
 Queue shown is maximum after two cycles.

Splits and Phases: 8: US 64 & SR 1634 (Carolina Village Rd)



Lanes, Volumes, Timings
 9: SR 1783 (Upward Rd) & I-26 NB On-Ramp

2011 Base Year - No Build

Timing Plan: PM Peak



Lane Group	EBL	EBT	EBR	WBL	WBT	WBR	NBL	NBT	NBR	SBL	SBT	SBR
Lane Configurations		↕			↑	↗	↗		↗			
Volume (vph)	418	387	0	0	282	114	207	0	100	0	0	0
Ideal Flow (vphpl)	1900	1900	1900	1900	1900	1900	1900	1900	1900	1900	1900	1900
Storage Length (ft)	0		0	0		50	150		0	0		0
Storage Lanes	0		0	0		1	1		1	0		0
Taper Length (ft)	100		100	100		100	100		100	100		100
Lane Util. Factor	1.00	1.00	1.00	1.00	1.00	1.00	1.00	1.00	1.00	1.00	1.00	1.00
Fr _t						0.850			0.850			
Fl _t Protected		0.975					0.950					
Satd. Flow (prot)	0	1762	0	0	1863	1495	1770	0	1583	0	0	0
Fl _t Permitted		0.680					0.950					
Satd. Flow (perm)	0	1229	0	0	1863	1495	1770	0	1583	0	0	0
Right Turn on Red			No			No			No			No
Satd. Flow (RTOR)												
Link Speed (mph)		45			45			45				45
Link Distance (ft)		630			322			446				658
Travel Time (s)		9.5			4.9			6.8				10.0
Peak Hour Factor	0.90	0.90	0.90	0.90	0.90	0.90	0.90	0.90	0.90	0.90	0.90	0.90
Heavy Vehicles (%)	8%	2%	5%	5%	2%	8%	2%	5%	2%	5%	5%	5%
Adj. Flow (vph)	464	430	0	0	313	127	230	0	111	0	0	0
Shared Lane Traffic (%)												
Lane Group Flow (vph)	0	894	0	0	313	127	230	0	111	0	0	0
Turn Type	Perm					Perm	Prot		custom			
Protected Phases		2			6		8					
Permitted Phases	2					6			8			
Detector Phase	2	2			6	6	8		8			
Switch Phase												
Minimum Initial (s)	12.0	12.0			12.0	12.0	7.0		7.0			
Minimum Split (s)	21.0	21.0			21.0	21.0	14.0		14.0			
Total Split (s)	74.0	74.0	0.0	0.0	74.0	74.0	16.0	0.0	16.0	0.0	0.0	0.0
Total Split (%)	82.2%	82.2%	0.0%	0.0%	82.2%	82.2%	17.8%	0.0%	17.8%	0.0%	0.0%	0.0%
Maximum Green (s)	67.0	67.0			67.0	67.0	9.0		9.0			
Yellow Time (s)	5.0	5.0			5.0	5.0	5.0		5.0			
All-Red Time (s)	2.0	2.0			2.0	2.0	2.0		2.0			
Lost Time Adjust (s)	-2.0	-2.0	-2.0	-2.0	-2.0	-2.0	-2.0	-2.0	-2.0	-2.0	-2.0	-2.0
Total Lost Time (s)	5.0	5.0	2.0	2.0	5.0	5.0	5.0	2.0	5.0	2.0	2.0	2.0
Lead/Lag												
Lead-Lag Optimize?												
Vehicle Extension (s)	3.0	3.0			3.0	3.0	3.0		3.0			
Recall Mode	C-Max	C-Max			C-Max	C-Max	None		None			
Act Effct Green (s)		69.0			69.0	69.0	11.0		11.0			
Actuated g/C Ratio		0.77			0.77	0.77	0.12		0.12			
v/c Ratio		0.95			0.22	0.11	1.06		0.58			
Control Delay		26.1			3.4	2.9	119.7		50.1			
Queue Delay		2.6			0.0	0.0	0.0		0.0			
Total Delay		28.7			3.4	2.9	119.7		50.1			
LOS		C			A	A	F		D			
Approach Delay		28.7			3.2							
Approach LOS		C			A							

Lanes, Volumes, Timings
 9: SR 1783 (Upward Rd) & I-26 NB On-Ramp

2011 Base Year - No Build
 Timing Plan: PM Peak



Lane Group	EBL	EBT	EBR	WBL	WBT	WBR	NBL	NBT	NBR	SBL	SBT	SBR
Queue Length 50th (ft)		453			39	15	~146		61			
Queue Length 95th (ft)		#736			61	27	#288		#119			
Internal Link Dist (ft)		550			242			366			578	
Turn Bay Length (ft)						50	150					
Base Capacity (vph)		942			1428	1146	216		193			
Starvation Cap Reductn		20			0	0	0		0			
Spillback Cap Reductn		0			0	0	0		0			
Storage Cap Reductn		0			0	0	0		0			
Reduced v/c Ratio		0.97			0.22	0.11	1.06		0.58			

Intersection Summary

Area Type: Other
 Cycle Length: 90
 Actuated Cycle Length: 90
 Offset: 13 (14%), Referenced to phase 2:EBTL and 6:WBT, Start of Green
 Natural Cycle: 90
 Control Type: Actuated-Coordinated
 Maximum v/c Ratio: 1.06
 Intersection Signal Delay: 35.9
 Intersection LOS: D
 Intersection Capacity Utilization 81.5%
 ICU Level of Service D
 Analysis Period (min) 15
 ~ Volume exceeds capacity, queue is theoretically infinite.
 Queue shown is maximum after two cycles.
 # 95th percentile volume exceeds capacity, queue may be longer.
 Queue shown is maximum after two cycles.



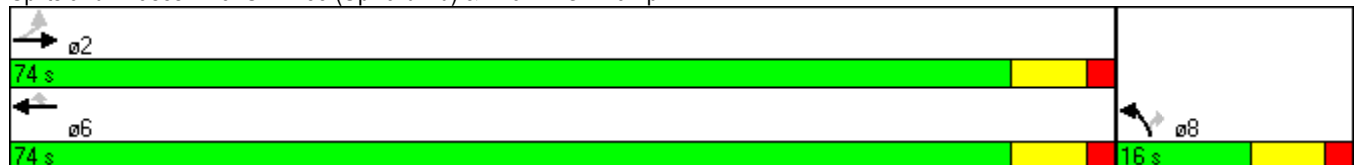













Splits and Phases: 9: SR 1783 (Upward Rd) & I-26 NB On-Ramp



Lanes, Volumes, Timings
 10: SR 1783 (Upward Rd) & I-26 SB Off-Ramp

2011 Base Year - No Build

Timing Plan: PM Peak

												
Lane Group	EBL	EBT	EBR	WBL	WBT	WBR	NBL	NBT	NBR	SBL	SBT	SBR
Lane Configurations												
Volume (vph)	0	687	212	78	411	0	0	0	0	118	0	329
Ideal Flow (vphpl)	1900	1900	1900	1900	1900	1900	1900	1900	1900	1900	1900	1900
Storage Length (ft)	0		200	0		0	0		0	0		100
Storage Lanes	0		1	0		0	0		0	1		1
Taper Length (ft)	100		100	100		100	100		100	100		100
Lane Util. Factor	1.00	1.00	1.00	1.00	1.00	1.00	1.00	1.00	1.00	1.00	1.00	1.00
Frt			0.850									0.850
Flt Protected					0.992					0.950		
Satd. Flow (prot)	0	1863	1495	0	1831	0	0	0	0	1770	0	1583
Flt Permitted					0.626					0.950		
Satd. Flow (perm)	0	1863	1495	0	1155	0	0	0	0	1770	0	1583
Right Turn on Red			No			No			No			No
Satd. Flow (RTOR)												
Link Speed (mph)		45			45			45			45	
Link Distance (ft)		549			630			547			651	
Travel Time (s)		8.3			9.5			8.3			9.9	
Peak Hour Factor	0.90	0.90	0.90	0.90	0.90	0.90	0.90	0.90	0.90	0.90	0.90	0.90
Heavy Vehicles (%)	5%	2%	8%	8%	2%	5%	5%	5%	5%	2%	5%	2%
Adj. Flow (vph)	0	763	236	87	457	0	0	0	0	131	0	366
Shared Lane Traffic (%)												
Lane Group Flow (vph)	0	763	236	0	544	0	0	0	0	131	0	366
Turn Type			Perm	Perm						Prot		custom
Protected Phases		2			6					4		
Permitted Phases			2	6								4
Detector Phase		2	2	6	6					4		4
Switch Phase												
Minimum Initial (s)		12.0	12.0	12.0	12.0					7.0		7.0
Minimum Split (s)		21.0	21.0	21.0	21.0					14.0		14.0
Total Split (s)	0.0	59.0	59.0	59.0	59.0	0.0	0.0	0.0	0.0	31.0	0.0	31.0
Total Split (%)	0.0%	65.6%	65.6%	65.6%	65.6%	0.0%	0.0%	0.0%	0.0%	34.4%	0.0%	34.4%
Maximum Green (s)		52.0	52.0	52.0	52.0					24.0		24.0
Yellow Time (s)		5.0	5.0	5.0	5.0					5.0		5.0
All-Red Time (s)		2.0	2.0	2.0	2.0					2.0		2.0
Lost Time Adjust (s)	-2.0	-2.0	-2.0	-2.0	-2.0	-2.0	-2.0	-2.0	-2.0	-2.0	-2.0	-2.0
Total Lost Time (s)	2.0	5.0	5.0	5.0	5.0	2.0	2.0	2.0	2.0	5.0	2.0	5.0
Lead/Lag												
Lead-Lag Optimize?												
Vehicle Extension (s)		3.0	3.0	3.0	3.0					3.0		3.0
Recall Mode		C-Max	C-Max	C-Max	C-Max					None		None
Act Effct Green (s)		55.4	55.4		55.4					24.6		24.6
Actuated g/C Ratio		0.62	0.62		0.62					0.27		0.27
v/c Ratio		0.67	0.26		0.77					0.27		0.85
Control Delay		15.3	9.2		19.2					26.8		49.8
Queue Delay		0.3	0.0		0.0					0.0		0.0
Total Delay		15.6	9.2		19.2					26.8		49.8
LOS		B	A		B					C		D
Approach Delay		14.1			19.2							
Approach LOS		B			B							

Lanes, Volumes, Timings
 10: SR 1783 (Upward Rd) & I-26 SB Off-Ramp

2011 Base Year - No Build
 Timing Plan: PM Peak



Lane Group	EBL	EBT	EBR	WBL	WBT	WBR	NBL	NBT	NBR	SBL	SBT	SBR
Queue Length 50th (ft)		269	58		287					57		192
Queue Length 95th (ft)		400	98		m348					104		#335
Internal Link Dist (ft)		469			550			467			571	
Turn Bay Length (ft)			200									100
Base Capacity (vph)		1147	920		711					511		457
Starvation Cap Reductn		0	0		0					0		0
Spillback Cap Reductn		80	0		0					13		0
Storage Cap Reductn		0	0		0					0		0
Reduced v/c Ratio		0.72	0.26		0.77					0.26		0.80

Intersection Summary

Area Type: Other
 Cycle Length: 90
 Actuated Cycle Length: 90
 Offset: 4 (4%), Referenced to phase 2:EBT and 6:WBTL, Start of Green
 Natural Cycle: 60
 Control Type: Actuated-Coordinated
 Maximum v/c Ratio: 0.85
 Intersection Signal Delay: 22.7
 Intersection LOS: C
 Intersection Capacity Utilization 80.3%
 ICU Level of Service D
 Analysis Period (min) 15
 # 95th percentile volume exceeds capacity, queue may be longer.
 Queue shown is maximum after two cycles.
 m Volume for 95th percentile queue is metered by upstream signal.

Splits and Phases: 10: SR 1783 (Upward Rd) & I-26 SB Off-Ramp

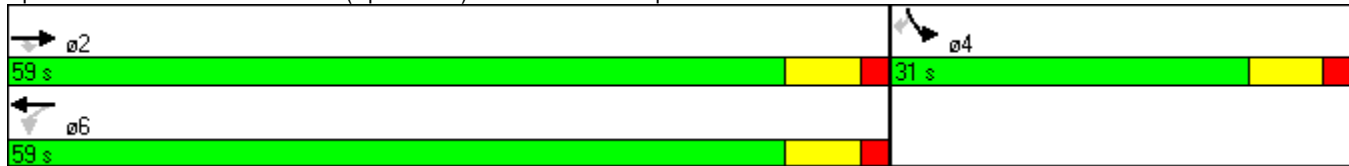

2011 Build 6 Lane

Lanes, Volumes, Timings
 1: NC 146 (Long Shoals Rd) & I-26 NB On-Ramp

2011 Base Year - Build 6 Lanes

Timing Plan: AM Peak

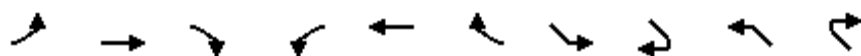

Lane Group	EBL	EBT	EBR2	WBL	WBT	WBR2	SEL	SER2	NWL	NWR2
Lane Configurations										
Volume (vph)	172	452	178	481	602	762	725	218	180	365
Ideal Flow (vphpl)	1900	1900	1900	1900	1900	1900	1900	1900	1900	1900
Grade (%)		3%			-7%					
Storage Length (ft)	450			350			0		675	
Storage Lanes	1			2			2		1	
Taper Length (ft)	100			100			100		100	
Lane Util. Factor	0.97	0.95	1.00	0.97	0.95	1.00	0.97	1.00	0.97	1.00
Frt			0.850			0.850		0.850		0.850
Flt Protected	0.950			0.950			0.950		0.950	
Satd. Flow (prot)	3224	3452	1487	3387	3663	1562	3519	1607	3434	1599
Flt Permitted	0.950			0.950			0.950		0.950	
Satd. Flow (perm)	3224	3452	1487	3387	3663	1562	3519	1607	3434	1599
Right Turn on Red			No			No		No		No
Satd. Flow (RTOR)										
Link Speed (mph)		45			45					
Link Distance (ft)		1009			964					
Travel Time (s)		15.3			14.6					
Peak Hour Factor	0.90	0.90	0.90	0.90	0.90	0.90	0.90	0.90	0.90	0.90
Heavy Vehicles (%)	7%	3%	7%	7%	2%	7%	2%	3%	3%	2%
Adj. Flow (vph)	191	502	198	534	669	847	806	242	200	406
Shared Lane Traffic (%)										
Lane Group Flow (vph)	191	502	198	534	669	847	806	242	200	406
Turn Type	Prot		Free	Prot		Free	Prot	custom	Prot	Free
Protected Phases	5	2		1	6		4		8	
Permitted Phases			Free			Free		4		Free
Detector Phase	5	2		1	6		4	4	8	
Switch Phase										
Minimum Initial (s)	7.0	12.0		7.0	12.0		7.0	7.0	7.0	
Minimum Split (s)	16.0	20.0		15.0	21.0		16.0	16.0	15.0	
Total Split (s)	16.0	45.0	0.0	28.0	57.0	0.0	27.0	27.0	27.0	0.0
Total Split (%)	16.0%	45.0%	0.0%	28.0%	57.0%	0.0%	27.0%	27.0%	27.0%	0.0%
Maximum Green (s)	7.8	37.5		20.3	48.0		18.9	18.9	19.0	
Yellow Time (s)	3.4	4.3		4.0	5.2		3.8	3.8	3.7	
All-Red Time (s)	4.8	3.2		3.7	3.8		4.3	4.3	4.3	
Lost Time Adjust (s)	-3.2	-2.5	-2.5	-2.7	-4.0	-4.0	-3.1	-3.1	-3.0	0.0
Total Lost Time (s)	5.0	5.0	1.5	5.0	5.0	0.0	5.0	5.0	5.0	4.0
Lead/Lag	Lead	Lag		Lead	Lag					
Lead-Lag Optimize?	Yes	Yes		Yes	Yes					
Vehicle Extension (s)	2.0	6.0		2.0	6.0		2.0	2.0	2.0	
Minimum Gap (s)	3.0	3.0		3.0	3.0		3.0	3.0	3.0	
Time Before Reduce (s)	0.0	15.0		0.0	15.0		0.0	0.0	0.0	
Time To Reduce (s)	0.0	30.0		0.0	30.0		0.0	0.0	0.0	
Recall Mode	None	C-Max		None	C-Max		None	None	None	
Act Effct Green (s)	10.8	41.7	100.0	21.3	52.2	100.0	22.0	22.0	22.0	100.0
Actuated g/C Ratio	0.11	0.42	1.00	0.21	0.52	1.00	0.22	0.22	0.22	1.00
v/c Ratio	0.55	0.35	0.13	0.74	0.35	0.54	1.04	0.68	0.26	0.25
Control Delay	48.6	21.2	0.2	43.3	14.7	1.4	82.6	47.0	33.4	0.4
Queue Delay	0.0	0.0	0.0	0.0	0.0	0.0	0.0	0.0	0.0	0.0

Lanes, Volumes, Timings
 1: NC 146 (Long Shoals Rd) & I-26 NB On-Ramp

2011 Base Year - Build 6 Lanes

Timing Plan: AM Peak

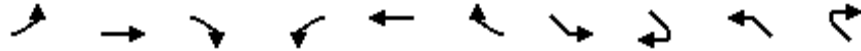

Lane Group	EBL	EBT	EBR2	WBL	WBT	WBR2	SEL	SER2	NWL	NWR2
Total Delay	48.6	21.2	0.2	43.3	14.7	1.4	82.6	47.0	33.4	0.4
LOS	D	C	A	D	B	A	F	D	C	A
Approach Delay	22.4			16.6						
Approach LOS	C			B						
Queue Length 50th (ft)	60	115	0	161	125	0	~288	142	54	0
Queue Length 95th (ft)	96	158	0	218	165	0	#405	#231	86	0
Internal Link Dist (ft)	929			884						
Turn Bay Length (ft)	450		300	350		300		425	675	575
Base Capacity (vph)	355	1438	1487	779	1911	1562	774	354	755	1599
Starvation Cap Reductn	0	0	0	0	0	0	0	0	0	0
Spillback Cap Reductn	0	0	0	0	0	0	0	0	0	0
Storage Cap Reductn	0	0	0	0	0	0	0	0	0	0
Reduced v/c Ratio	0.54	0.35	0.13	0.69	0.35	0.54	1.04	0.68	0.26	0.25

Intersection Summary

Area Type: Other
 Cycle Length: 100
 Actuated Cycle Length: 100
 Offset: 0 (0%), Referenced to phase 2:EBT and 6:WBT, Start of Green
 Natural Cycle: 60
 Control Type: Actuated-Coordinated
 Maximum v/c Ratio: 1.04
 Intersection Signal Delay: 30.2
 Intersection LOS: C
 Intersection Capacity Utilization 59.4%
 ICU Level of Service B
 Analysis Period (min) 15
 ~ Volume exceeds capacity, queue is theoretically infinite.
 Queue shown is maximum after two cycles.
 # 95th percentile volume exceeds capacity, queue may be longer.
 Queue shown is maximum after two cycles.

Splits and Phases: 1: NC 146 (Long Shoals Rd) & I-26 NB On-Ramp

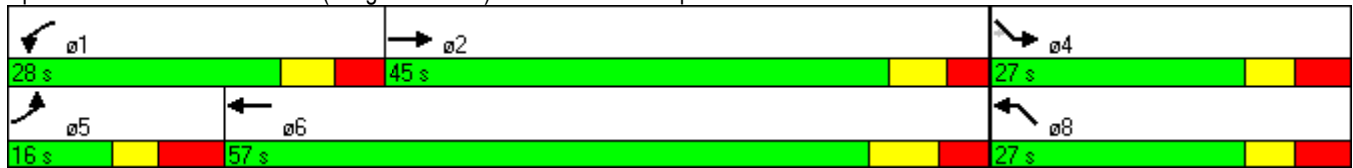

Lanes, Volumes, Timings
2: I-26 NB On-Ramp & US 25 (Asheville Highway)

2011 Base Year - Build 6 Lanes

Timing Plan: AM Peak



Lane Group	EBL	EBT	EBR	WBL	WBT	WBR	NBL	NBT	NBR	SBL	SBT	SBR
Lane Configurations				↙		↗	↗	↗			↗	↗
Volume (vph)	0	0	0	107	0	239	487	879	0	0	1232	239
Ideal Flow (vphpl)	1900	1900	1900	1900	1900	1900	1900	1900	1900	1900	1900	1900
Grade (%)		0%			2%			-1%			2%	
Storage Length (ft)	0		0	0		150	0		0	0		300
Storage Lanes	0		0	1		2	1		0	0		1
Taper Length (ft)	100		100	100		100	100		100	100		100
Lane Util. Factor	1.00	1.00	1.00	1.00	1.00	0.88	1.00	0.95	1.00	1.00	0.95	1.00
Frt						0.850						0.850
Flt Protected				0.950			0.950					
Satd. Flow (prot)	0	0	0	1735	0	2706	1680	3489	0	0	3436	1480
Flt Permitted				0.950			0.950					
Satd. Flow (perm)	0	0	0	1735	0	2706	1680	3489	0	0	3436	1480
Right Turn on Red			No			Yes			No			No
Satd. Flow (RTOR)						266						
Link Speed (mph)		45			35			45			45	
Link Distance (ft)		533			612			601			596	
Travel Time (s)		8.1			11.9			9.1			9.0	
Peak Hour Factor	0.90	0.90	0.90	0.90	0.90	0.90	0.90	0.90	0.90	0.90	0.90	0.90
Heavy Vehicles (%)	5%	5%	5%	3%	5%	4%	8%	4%	5%	5%	4%	8%
Adj. Flow (vph)	0	0	0	119	0	266	541	977	0	0	1369	266
Shared Lane Traffic (%)												
Lane Group Flow (vph)	0	0	0	119	0	266	541	977	0	0	1369	266
Turn Type				Prot		custom	Prot					Free
Protected Phases				4			5	2			6	
Permitted Phases						4						Free
Detector Phase				4		4	5	2			6	
Switch Phase												
Minimum Initial (s)				7.0		7.0	7.0	12.0			12.0	
Minimum Split (s)				13.0		13.0	14.0	19.0			18.0	
Total Split (s)	0.0	0.0	0.0	14.0	0.0	14.0	43.0	96.0	0.0	0.0	53.0	0.0
Total Split (%)	0.0%	0.0%	0.0%	12.7%	0.0%	12.7%	39.1%	87.3%	0.0%	0.0%	48.2%	0.0%
Maximum Green (s)				8.0		8.0	36.6	89.9			47.7	
Yellow Time (s)				3.7		3.7	3.0	4.6			4.3	
All-Red Time (s)				2.3		2.3	3.4	1.5			1.0	
Lost Time Adjust (s)	-2.0	0.0	0.0	-1.0	0.0	-1.0	-1.4	-1.1	0.0	0.0	-0.3	0.0
Total Lost Time (s)	2.0	4.0	4.0	5.0	4.0	5.0	5.0	5.0	4.0	4.0	5.0	4.0
Lead/Lag							Lag				Lead	
Lead-Lag Optimize?							Yes				Yes	
Vehicle Extension (s)				2.0		2.0	2.0	8.0			8.0	
Minimum Gap (s)				3.0		3.0	3.0	5.5			5.5	
Time Before Reduce (s)				0.0		0.0	0.0	15.0			15.0	
Time To Reduce (s)				0.0		0.0	0.0	50.0			50.0	
Recall Mode				None		None	None	C-Max			C-Max	
Act Effct Green (s)				9.0		9.0	38.0	91.0			48.0	110.0
Actuated g/C Ratio				0.08		0.08	0.35	0.83			0.44	1.00
v/c Ratio				0.84		0.57	0.93	0.34			0.91	0.18
Control Delay				92.7		11.2	17.7	1.4			39.7	0.3
Queue Delay				0.0		0.0	0.0	0.0			0.0	0.0

Lanes, Volumes, Timings
 2: I-26 NB On-Ramp & US 25 (Asheville Highway)

2011 Base Year - Build 6 Lanes

Timing Plan: AM Peak



Lane Group	EBL	EBT	EBR	WBL	WBT	WBR	NBL	NBT	NBR	SBL	SBT	SBR
Total Delay				92.7		11.2	17.7	1.4			39.7	0.3
LOS				F		B	B	A			D	A
Approach Delay								7.2			33.3	
Approach LOS								A			C	
Queue Length 50th (ft)				84		0	71	52			465	0
Queue Length 95th (ft)				#190		43	m65	m27			#616	0
Internal Link Dist (ft)		453			532			521			516	
Turn Bay Length (ft)						150						300
Base Capacity (vph)				142		466	580	2886			1499	1480
Starvation Cap Reductn				0		0	0	0			0	0
Spillback Cap Reductn				0		0	0	0			0	0
Storage Cap Reductn				0		0	0	0			0	0
Reduced v/c Ratio				0.84		0.57	0.93	0.34			0.91	0.18

Intersection Summary

Area Type: Other
 Cycle Length: 110
 Actuated Cycle Length: 110
 Offset: 14 (13%), Referenced to phase 2:NBT and 6:SBT, Start of Green
 Natural Cycle: 90
 Control Type: Actuated-Coordinated
 Maximum v/c Ratio: 0.93
 Intersection Signal Delay: 22.4
 Intersection LOS: C
 Intersection Capacity Utilization 80.0%
 ICU Level of Service D
 Analysis Period (min) 15
 # 95th percentile volume exceeds capacity, queue may be longer.
 Queue shown is maximum after two cycles.
 m Volume for 95th percentile queue is metered by upstream signal.

Splits and Phases: 2: I-26 NB On-Ramp & US 25 (Asheville Highway)

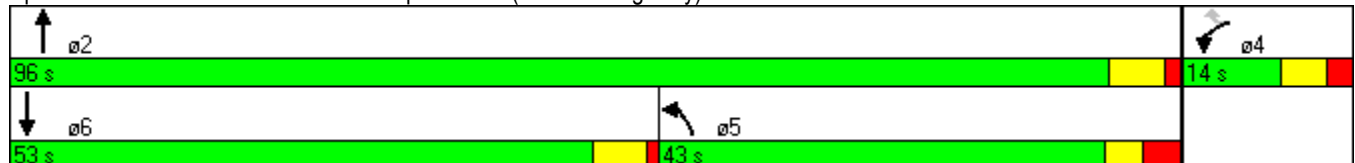

Lanes, Volumes, Timings
 3: I-26 SB Off-Ramp & US 25 (Asheville Highway)

2011 Base Year - Build 6 Lanes
 Timing Plan: AM Peak



Lane Group	EBL	EBT	EBR	WBL	WBT	WBR	NBL	NBT	NBR	SBL	SBT	SBR
Lane Configurations												
Volume (vph)	235	0	602	0	0	0	0	1131	107	419	920	0
Ideal Flow (vphpl)	1900	1900	1900	1900	1900	1900	1900	1900	1900	1900	1900	1900
Grade (%)		3%			0%			4%			1%	
Storage Length (ft)	0		100	0		0	0		500	0		0
Storage Lanes	1		1	0		0	0		1	1		0
Taper Length (ft)	100		100	100		100	100		100	100		100
Lane Util. Factor	1.00	1.00	1.00	1.00	1.00	1.00	1.00	0.95	1.00	1.00	0.95	1.00
Frt			0.850						0.850			
Flt Protected	0.950									0.950		
Satd. Flow (prot)	1710	0	1544	0	0	0	0	3435	1465	1663	3487	0
Flt Permitted	0.950									0.950		
Satd. Flow (perm)	1710	0	1544	0	0	0	0	3435	1465	1663	3487	0
Right Turn on Red			No			No			No			No
Satd. Flow (RTOR)												
Link Speed (mph)		35			45			45			45	
Link Distance (ft)		471			598			795			601	
Travel Time (s)		9.2			9.1			12.0			9.1	
Peak Hour Factor	0.90	0.90	0.90	0.90	0.90	0.90	0.90	0.90	0.90	0.90	0.90	0.90
Heavy Vehicles (%)	4%	5%	3%	5%	5%	5%	5%	3%	8%	8%	3%	5%
Adj. Flow (vph)	261	0	669	0	0	0	0	1257	119	466	1022	0
Shared Lane Traffic (%)												
Lane Group Flow (vph)	261	0	669	0	0	0	0	1257	119	466	1022	0
Turn Type	Prot		custom						Free	Prot		
Protected Phases	4		4					2		1	6	
Permitted Phases									Free			
Detector Phase	4		4					2		1	6	
Switch Phase												
Minimum Initial (s)	7.0		7.0					12.0		7.0	12.0	
Minimum Split (s)	13.0		13.0					18.0		14.0	18.0	
Total Split (s)	42.0	0.0	42.0	0.0	0.0	0.0	0.0	39.0	0.0	29.0	68.0	0.0
Total Split (%)	38.2%	0.0%	38.2%	0.0%	0.0%	0.0%	0.0%	35.5%	0.0%	26.4%	61.8%	0.0%
Maximum Green (s)	36.0		36.0					33.3		22.5	62.3	
Yellow Time (s)	4.0		4.0					4.7		4.0	4.7	
All-Red Time (s)	2.0		2.0					1.0		2.5	1.0	
Lost Time Adjust (s)	-1.0	-2.0	-1.0	-2.0	-2.0	-2.0	-2.0	-0.7	-0.7	-1.5	-0.7	-2.0
Total Lost Time (s)	5.0	2.0	5.0	2.0	2.0	2.0	2.0	5.0	3.3	5.0	5.0	2.0
Lead/Lag								Lag		Lead		
Lead-Lag Optimize?								Yes		Yes		
Vehicle Extension (s)	2.0		2.0					8.0		2.0	8.0	
Minimum Gap (s)	3.0		3.0					5.5		3.0	5.5	
Time Before Reduce (s)	0.0		0.0					15.0		0.0	15.0	
Time To Reduce (s)	0.0		0.0					50.0		0.0	50.0	
Recall Mode	None		None					C-Max		None	C-Max	
Act Effct Green (s)	37.0		37.0					34.0	110.0	24.0	63.0	
Actuated g/C Ratio	0.34		0.34					0.31	1.00	0.22	0.57	
v/c Ratio	0.45		1.29					1.18	0.08	1.28	0.51	
Control Delay	31.7		176.5					127.4	0.1	162.7	6.7	
Queue Delay	0.0		0.0					0.0	0.0	0.0	1.2	

Lanes, Volumes, Timings
 3: I-26 SB Off-Ramp & US 25 (Asheville Highway)

2011 Base Year - Build 6 Lanes

Timing Plan: AM Peak



Lane Group	EBL	EBT	EBR	WBL	WBT	WBR	NBL	NBT	NBR	SBL	SBT	SBR
Total Delay	31.7		176.5					127.4	0.1	162.7	7.9	
LOS	C		F					F	A	F	A	
Approach Delay								116.4			56.3	
Approach LOS								F			E	
Queue Length 50th (ft)	143		~603					~563	0	~405	182	
Queue Length 95th (ft)	221		#827					#698	0	m#477	m194	
Internal Link Dist (ft)		391			518			715			521	
Turn Bay Length (ft)			100						500			
Base Capacity (vph)	575		519					1062	1465	363	1997	
Starvation Cap Reductn	0		0					0	0	0	688	
Spillback Cap Reductn	0		0					0	0	0	0	
Storage Cap Reductn	0		0					0	0	0	0	
Reduced v/c Ratio	0.45		1.29					1.18	0.08	1.28	0.78	

Intersection Summary

Area Type: Other
 Cycle Length: 110
 Actuated Cycle Length: 110
 Offset: 61 (55%), Referenced to phase 2:NBT and 6:SBT, Start of Green
 Natural Cycle: 150
 Control Type: Actuated-Coordinated
 Maximum v/c Ratio: 1.29
 Intersection Signal Delay: 97.6
 Intersection Capacity Utilization 80.0%
 Analysis Period (min) 15
 Intersection LOS: F
 ICU Level of Service D

~ Volume exceeds capacity, queue is theoretically infinite.
 Queue shown is maximum after two cycles.

95th percentile volume exceeds capacity, queue may be longer.
 Queue shown is maximum after two cycles.

m Volume for 95th percentile queue is metered by upstream signal.

Splits and Phases: 3: I-26 SB Off-Ramp & US 25 (Asheville Highway)

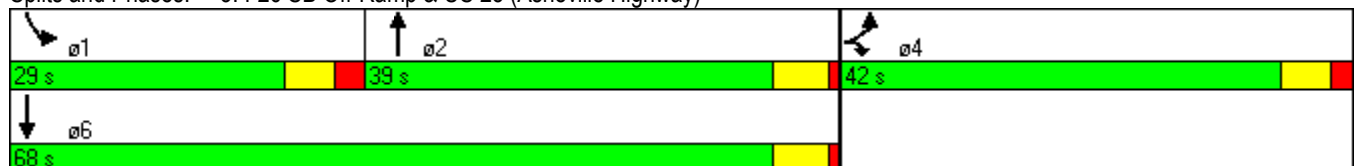

Lanes, Volumes, Timings
6: US 64 & SR 1516 (Francis Rd)

2011 Base Year - Build 6 Lanes

Timing Plan: AM Peak



Lane Group	EBL	EBT	EBR	WBL	WBT	WBR	NBL	NBT	NBR	SBL	SBT	SBR
Lane Configurations												
Volume (vph)	122	1494	386	82	1895	26	343	5	58	26	5	122
Ideal Flow (vphpl)	1900	1900	1900	1900	1900	1900	1900	1900	1900	1900	1900	1900
Grade (%)		-1%			4%			-1%			2%	
Storage Length (ft)	150		0	125		0	150		150	0		150
Storage Lanes	1		1	1		0	1		1	0		1
Taper Length (ft)	100		100	100		100	100		100	100		100
Lane Util. Factor	1.00	0.95	1.00	1.00	0.95	0.95	0.95	0.95	1.00	1.00	1.00	1.00
Frt			0.850		0.998				0.850			0.850
Flt Protected	0.950			0.950			0.950	0.954			0.960	
Satd. Flow (prot)	1778	3557	1591	1734	3461	0	1690	1697	1591	0	1770	1567
Flt Permitted	0.950			0.950			0.950	0.954			0.960	
Satd. Flow (perm)	1778	3557	1591	1734	3461	0	1690	1697	1591	0	1770	1567
Right Turn on Red			No			No			No			No
Satd. Flow (RTOR)												
Link Speed (mph)		45			45			35			35	
Link Distance (ft)		835			622			375			406	
Travel Time (s)		12.7			9.4			7.3			7.9	
Peak Hour Factor	0.90	0.90	0.90	0.90	0.90	0.90	0.90	0.90	0.90	0.90	0.90	0.90
Heavy Vehicles (%)	2%	2%	2%	2%	2%	2%	2%	2%	2%	2%	2%	2%
Adj. Flow (vph)	136	1660	429	91	2106	29	381	6	64	29	6	136
Shared Lane Traffic (%)							49%					
Lane Group Flow (vph)	136	1660	429	91	2135	0	194	193	64	0	35	136
Turn Type	Prot		Perm	Prot			Split		pm+ov	Split		pm+ov
Protected Phases	5	2		1	6		4	4	1	3	3	5
Permitted Phases			2						4			3
Detector Phase	5	2	2	1	6		4	4	1	3	3	5
Switch Phase												
Minimum Initial (s)	7.0	12.0	12.0	7.0	12.0		7.0	7.0	7.0	7.0	7.0	7.0
Minimum Split (s)	13.0	18.0	18.0	13.0	18.0		14.0	14.0	13.0	14.0	14.0	13.0
Total Split (s)	14.0	83.0	83.0	14.0	83.0	0.0	19.0	19.0	14.0	14.0	14.0	14.0
Total Split (%)	10.8%	63.8%	63.8%	10.8%	63.8%	0.0%	14.6%	14.6%	10.8%	10.8%	10.8%	10.8%
Maximum Green (s)	8.4	77.0	77.0	8.6	77.4		12.4	12.4	8.6	7.5	7.5	8.4
Yellow Time (s)	3.2	4.6	4.6	3.0	4.2		3.9	3.9	3.0	3.7	3.7	3.2
All-Red Time (s)	2.4	1.4	1.4	2.4	1.4		2.7	2.7	2.4	2.8	2.8	2.4
Lost Time Adjust (s)	-0.6	-1.0	-1.0	-0.4	-0.6	-2.0	-1.6	-1.6	-0.4	-2.0	-1.5	-0.6
Total Lost Time (s)	5.0	5.0	5.0	5.0	5.0	2.0	5.0	5.0	5.0	4.5	5.0	5.0
Lead/Lag	Lag	Lag	Lag	Lead	Lead		Lag	Lag	Lead	Lead	Lead	Lag
Lead-Lag Optimize?	Yes	Yes	Yes	Yes	Yes		Yes	Yes	Yes	Yes	Yes	Yes
Vehicle Extension (s)	1.0	2.0	2.0	1.0	2.0		1.0	1.0	1.0	1.0	1.0	1.0
Recall Mode	None	C-Max	C-Max	None	C-Max		None	None	None	None	None	None
Act Effct Green (s)	9.0	80.0	80.0	8.8	79.8		17.9	17.9	31.7		8.6	17.2
Actuated g/C Ratio	0.07	0.62	0.62	0.07	0.61		0.14	0.14	0.24		0.07	0.13
v/c Ratio	1.11	0.76	0.44	0.78	1.00		0.83	0.82	0.16		0.30	0.65
Control Delay	163.8	18.4	11.1	98.3	46.1		83.3	82.3	41.9		64.6	67.3
Queue Delay	0.0	0.0	0.0	0.0	0.0		0.0	0.0	0.0		0.0	0.0
Total Delay	163.8	18.4	11.1	98.3	46.1		83.3	82.3	41.9		64.6	67.3
LOS	F	B	B	F	D		F	F	D		E	E
Approach Delay		25.9			48.2			77.0			66.7	

Lanes, Volumes, Timings
6: US 64 & SR 1516 (Francis Rd)

2011 Base Year - Build 6 Lanes

Timing Plan: AM Peak



Lane Group	EBL	EBT	EBR	WBL	WBT	WBR	NBL	NBT	NBR	SBL	SBT	SBR
Approach LOS	C			D			E			E		
Queue Length 50th (ft)	~130	602	169	77	~1010		~184	~181	44		29	105
Queue Length 95th (ft)	#268	702	239	#170	#1145		#355	#351	87		64	173
Internal Link Dist (ft)		755			542			295			326	
Turn Bay Length (ft)	150			125			150		150			150
Base Capacity (vph)	123	2190	980	121	2125		233	234	392		123	208
Starvation Cap Reductn	0	0	0	0	0		0	0	0		0	0
Spillback Cap Reductn	0	0	0	0	0		0	0	0		0	0
Storage Cap Reductn	0	0	0	0	0		0	0	0		0	0
Reduced v/c Ratio	1.11	0.76	0.44	0.75	1.00		0.83	0.82	0.16		0.28	0.65

Intersection Summary

Area Type: Other
 Cycle Length: 130
 Actuated Cycle Length: 130
 Offset: 99 (76%), Referenced to phase 2:EBT and 6:WBT, Start of Green
 Natural Cycle: 130
 Control Type: Actuated-Coordinated
 Maximum v/c Ratio: 1.11
 Intersection Signal Delay: 41.6
 Intersection LOS: D
 Intersection Capacity Utilization 88.8%
 ICU Level of Service E
 Analysis Period (min) 15
 ~ Volume exceeds capacity, queue is theoretically infinite.
 Queue shown is maximum after two cycles.
 # 95th percentile volume exceeds capacity, queue may be longer.
 Queue shown is maximum after two cycles.

Splits and Phases: 6: US 64 & SR 1516 (Francis Rd)



Lanes, Volumes, Timings
7: US 64 & I-26 SB Off-Ramp

2011 Base Year - Build 6 Lanes

Timing Plan: AM Peak

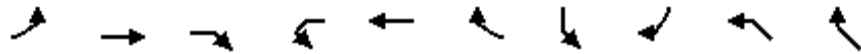

Lane Group	EBL	EBT	EBR	WBL	WBT	WBR	SBL	SBR	NWL	NWR
Lane Configurations		↑↑	↗		↑↑			↖↖		
Volume (vph)	0	1478	225	0	1684	0	0	426	0	0
Ideal Flow (vphpl)	1900	1900	1900	1900	1900	1900	1900	1900	1900	1900
Grade (%)		3%			-3%		-3%		0%	
Storage Length (ft)	0		400	0		0	0	500	0	0
Storage Lanes	0		1	0		0	0	1	0	0
Taper Length (ft)	100		100	100		100	100	100	100	100
Lane Util. Factor	1.00	0.95	1.00	1.00	0.95	1.00	1.00	0.88	1.00	1.00
Frt			0.850					0.850		
Flt Protected										
Satd. Flow (prot)	0	3486	1473	0	3592	0	0	2828	0	0
Flt Permitted										
Satd. Flow (perm)	0	3486	1473	0	3592	0	0	2828	0	0
Right Turn on Red			No			No		No		
Satd. Flow (RTOR)										
Link Speed (mph)		45			45		35		45	
Link Distance (ft)		728			791		804		308	
Travel Time (s)		11.0			12.0		15.7		4.7	
Peak Hour Factor	0.90	0.90	0.90	0.90	0.90	0.90	0.90	0.90	0.90	0.90
Heavy Vehicles (%)	5%	2%	8%	5%	2%	5%	5%	2%	5%	5%
Adj. Flow (vph)	0	1642	250	0	1871	0	0	473	0	0
Shared Lane Traffic (%)										
Lane Group Flow (vph)	0	1642	250	0	1871	0	0	473	0	0
Turn Type			Perm					custom		
Protected Phases		Free			6			4		
Permitted Phases			Free							
Detector Phase					6			4		
Switch Phase										
Minimum Initial (s)					12.0			7.0		
Minimum Split (s)					18.0			13.0		
Total Split (s)	0.0	0.0	0.0	0.0	92.0	0.0	0.0	38.0	0.0	0.0
Total Split (%)	0.0%	0.0%	0.0%	0.0%	70.8%	0.0%	0.0%	29.2%	0.0%	0.0%
Maximum Green (s)					86.2			32.9		
Yellow Time (s)					4.8			4.1		
All-Red Time (s)					1.0			1.0		
Lost Time Adjust (s)	-2.0	0.0	-2.0	-2.0	-0.8	-2.0	-2.0	-0.1	-2.0	-2.0
Total Lost Time (s)	2.0	4.0	2.0	2.0	5.0	2.0	2.0	5.0	2.0	2.0
Lead/Lag										
Lead-Lag Optimize?										
Vehicle Extension (s)					2.0			1.0		
Recall Mode					C-Max			None		
Act Effct Green (s)		130.0	130.0		94.6			25.4		
Actuated g/C Ratio		1.00	1.00		0.73			0.20		
v/c Ratio		0.47	0.17		0.72			0.86		
Control Delay		0.2	0.1		7.3			65.8		
Queue Delay		0.0	0.0		0.2			0.0		
Total Delay		0.2	0.1		7.6			65.8		
LOS		A	A		A			E		
Approach Delay		0.2			7.6					

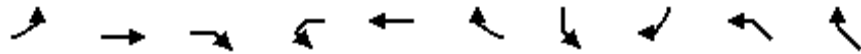

Lane Group	EBL	EBT	EBR	WBL	WBT	WBR	SBL	SBR	NWL	NWR
Approach LOS		A			A					
Queue Length 50th (ft)		0	0		215			221		
Queue Length 95th (ft)		0	m0		m452			273		
Internal Link Dist (ft)		648			711		724		228	
Turn Bay Length (ft)			400					500		
Base Capacity (vph)		3486	1473		2615			718		
Starvation Cap Reductn		0	0		0			0		
Spillback Cap Reductn		0	0		181			0		
Storage Cap Reductn		0	0		0			0		
Reduced v/c Ratio		0.47	0.17		0.77			0.66		

Intersection Summary

Area Type: Other
 Cycle Length: 130
 Actuated Cycle Length: 130
 Offset: 0 (0%), Referenced to phase 6:WBT, Start of Green, Master Intersection
 Natural Cycle: 60
 Control Type: Actuated-Coordinated
 Maximum v/c Ratio: 0.86
 Intersection Signal Delay: 10.8
 Intersection LOS: B
 Intersection Capacity Utilization 81.1%
 ICU Level of Service D
 Analysis Period (min) 15
 m Volume for 95th percentile queue is metered by upstream signal.

Splits and Phases: 7: US 64 & I-26 SB Off-Ramp



Lanes, Volumes, Timings
8: US 64 & SR 1634 (Carolina Village Rd)

2011 Base Year - Build 6 Lanes

Timing Plan: AM Peak



Lane Group	EBL	EBT	EBR	WBL	WBT	WBR	NBL	NBT	NBR	SBL	SBT	SBR
Lane Configurations												
Volume (vph)	58	1484	70	146	1834	111	66	10	112	123	15	79
Ideal Flow (vphpl)	1900	1900	1900	1900	1900	1900	1900	1900	1900	1900	1900	1900
Grade (%)		1%			-3%			3%				-1%
Storage Length (ft)	100		0	100		0	0		0	0		150
Storage Lanes	1		0	1		1	0		0	0		1
Taper Length (ft)	100		100	100		100	100		100	100		100
Lane Util. Factor	1.00	0.95	0.95	1.00	0.95	1.00	1.00	1.00	1.00	1.00	1.00	1.00
Frt		0.993				0.850		0.920				0.850
Flt Protected	0.950			0.950				0.983			0.957	
Satd. Flow (prot)	1761	3497	0	1796	3592	1607	0	1659	0	0	1792	1591
Flt Permitted	0.950			0.950				0.663			0.499	
Satd. Flow (perm)	1761	3497	0	1796	3592	1607	0	1119	0	0	934	1591
Right Turn on Red			No			No			No			No
Satd. Flow (RTOR)												
Link Speed (mph)		45			45			30			30	
Link Distance (ft)		560			728			219			359	
Travel Time (s)		8.5			11.0			5.0			8.2	
Peak Hour Factor	0.90	0.90	0.90	0.90	0.90	0.90	0.90	0.90	0.90	0.90	0.90	0.90
Heavy Vehicles (%)	2%	2%	2%	2%	2%	2%	2%	2%	2%	2%	2%	2%
Adj. Flow (vph)	64	1649	78	162	2038	123	73	11	124	137	17	88
Shared Lane Traffic (%)												
Lane Group Flow (vph)	64	1727	0	162	2038	123	0	208	0	0	154	88
Turn Type	Prot			Prot		Perm	Perm			Perm		pm+ov
Protected Phases	5	2		1	6			8			4	5
Permitted Phases						6	8			4		4
Detector Phase	5	2		1	6	6	8	8		4	4	5
Switch Phase												
Minimum Initial (s)	7.0	12.0		7.0	12.0	12.0	7.0	7.0		7.0	7.0	7.0
Minimum Split (s)	13.0	18.0		13.0	19.0	19.0	13.0	13.0		13.0	13.0	13.0
Total Split (s)	13.0	78.0	0.0	20.0	85.0	85.0	32.0	32.0	0.0	32.0	32.0	13.0
Total Split (%)	10.0%	60.0%	0.0%	15.4%	65.4%	65.4%	24.6%	24.6%	0.0%	24.6%	24.6%	10.0%
Maximum Green (s)	7.1	72.4		14.6	78.8	78.8	26.2	26.2		26.1	26.1	7.1
Yellow Time (s)	3.0	4.4		3.0	4.8	4.8	3.4	3.4		3.6	3.6	3.0
All-Red Time (s)	2.9	1.2		2.4	1.4	1.4	2.4	2.4		2.3	2.3	2.9
Lost Time Adjust (s)	-0.9	-0.6	-2.0	-0.4	-1.2	-1.2	-2.0	-0.8	-2.0	-2.0	-0.9	-0.9
Total Lost Time (s)	5.0	5.0	2.0	5.0	5.0	5.0	3.8	5.0	2.0	3.9	5.0	5.0
Lead/Lag	Lag	Lag		Lead	Lead	Lead						Lag
Lead-Lag Optimize?	Yes	Yes		Yes	Yes	Yes						Yes
Vehicle Extension (s)	1.0	2.0		1.0	2.0	2.0	1.0	1.0		1.0	1.0	1.0
Recall Mode	None	C-Max		None	C-Max	C-Max	None	None		None	None	None
Act Effct Green (s)	8.0	76.2		13.8	82.0	82.0		25.0			25.0	38.0
Actuated g/C Ratio	0.06	0.59		0.11	0.63	0.63		0.19			0.19	0.29
v/c Ratio	0.59	0.84		0.85	0.90	0.12		0.97			0.86	0.19
Control Delay	81.7	27.8		88.3	20.1	5.9		104.8			88.4	34.9
Queue Delay	0.0	0.0		0.0	1.7	0.0		0.0			0.0	0.0
Total Delay	81.7	27.8		88.3	21.8	5.9		104.8			88.4	34.9
LOS	F	C		F	C	A		F			F	C
Approach Delay		29.7			25.6			104.8			68.9	

Lanes, Volumes, Timings
 8: US 64 & SR 1634 (Carolina Village Rd)

2011 Base Year - Build 6 Lanes
 Timing Plan: AM Peak



Lane Group	EBL	EBT	EBR	WBL	WBT	WBR	NBL	NBT	NBR	SBL	SBT	SBR
Approach LOS		C			C			F			E	
Queue Length 50th (ft)	54	636		128	747	26		172			124	54
Queue Length 95th (ft)	#115	756		m#220	674	m35		#322			#242	98
Internal Link Dist (ft)		480			648			139			279	
Turn Bay Length (ft)	100			100								150
Base Capacity (vph)	108	2050		207	2264	1013		232			194	466
Starvation Cap Reductn	0	0		0	109	0		0			0	0
Spillback Cap Reductn	0	0		0	0	0		0			0	0
Storage Cap Reductn	0	0		0	0	0		0			0	0
Reduced v/c Ratio	0.59	0.84		0.78	0.95	0.12		0.90			0.79	0.19

Intersection Summary

Area Type: Other
 Cycle Length: 130
 Actuated Cycle Length: 130
 Offset: 26 (20%), Referenced to phase 2:EBT and 6:WBT, Start of Green
 Natural Cycle: 90
 Control Type: Actuated-Coordinated
 Maximum v/c Ratio: 0.97
 Intersection Signal Delay: 33.1
 Intersection LOS: C
 Intersection Capacity Utilization 86.8%
 ICU Level of Service E
 Analysis Period (min) 15
 # 95th percentile volume exceeds capacity, queue may be longer.
 Queue shown is maximum after two cycles.
 m Volume for 95th percentile queue is metered by upstream signal.

Splits and Phases: 8: US 64 & SR 1634 (Carolina Village Rd)



Lanes, Volumes, Timings
 9: SR 1783 (Upward Rd) & I-26 NB On-Ramp

2011 Base Year - Build 6 Lanes
 Timing Plan: AM Peak



Lane Group	EBL	EBT	EBR	WBL	WBT	WBR	NBL	NBT	NBR	SBL	SBT	SBR
Lane Configurations		↕			↑	↗	↗		↗			
Volume (vph)	358	302	0	0	342	114	210	0	69	0	0	0
Ideal Flow (vphpl)	1900	1900	1900	1900	1900	1900	1900	1900	1900	1900	1900	1900
Storage Length (ft)	0		0	0		50	150		0	0		0
Storage Lanes	0		0	0		1	1		1	0		0
Taper Length (ft)	100		100	100		100	100		100	100		100
Lane Util. Factor	1.00	1.00	1.00	1.00	1.00	1.00	1.00	1.00	1.00	1.00	1.00	1.00
Fr _t						0.850			0.850			
Fl _t Protected		0.974					0.950					
Satd. Flow (prot)	0	1758	0	0	1863	1495	1770	0	1583	0	0	0
Fl _t Permitted		0.626					0.950					
Satd. Flow (perm)	0	1130	0	0	1863	1495	1770	0	1583	0	0	0
Right Turn on Red			No			No			No			No
Satd. Flow (RTOR)												
Link Speed (mph)		45			45			45				45
Link Distance (ft)		630			322			446				658
Travel Time (s)		9.5			4.9			6.8				10.0
Peak Hour Factor	0.90	0.90	0.90	0.90	0.90	0.90	0.90	0.90	0.90	0.90	0.90	0.90
Heavy Vehicles (%)	8%	2%	5%	5%	2%	8%	2%	5%	2%	5%	5%	5%
Adj. Flow (vph)	398	336	0	0	380	127	233	0	77	0	0	0
Shared Lane Traffic (%)												
Lane Group Flow (vph)	0	734	0	0	380	127	233	0	77	0	0	0
Turn Type	Perm					Perm	Prot		custom			
Protected Phases		2			6		8					
Permitted Phases	2					6			8			
Detector Phase	2	2			6	6	8		8			
Switch Phase												
Minimum Initial (s)	12.0	12.0			12.0	12.0	7.0		7.0			
Minimum Split (s)	21.0	21.0			21.0	21.0	14.0		14.0			
Total Split (s)	71.0	71.0	0.0	0.0	71.0	71.0	19.0	0.0	19.0	0.0	0.0	0.0
Total Split (%)	78.9%	78.9%	0.0%	0.0%	78.9%	78.9%	21.1%	0.0%	21.1%	0.0%	0.0%	0.0%
Maximum Green (s)	64.0	64.0			64.0	64.0	12.0		12.0			
Yellow Time (s)	5.0	5.0			5.0	5.0	5.0		5.0			
All-Red Time (s)	2.0	2.0			2.0	2.0	2.0		2.0			
Lost Time Adjust (s)	-2.0	-2.0	-2.0	-2.0	-2.0	-2.0	-2.0	-2.0	-2.0	-2.0	-2.0	-2.0
Total Lost Time (s)	5.0	5.0	2.0	2.0	5.0	5.0	5.0	2.0	5.0	2.0	2.0	2.0
Lead/Lag												
Lead-Lag Optimize?												
Vehicle Extension (s)	3.0	3.0			3.0	3.0	3.0		3.0			
Recall Mode	C-Max	C-Max			C-Max	C-Max	None		None			
Act Effct Green (s)		66.0			66.0	66.0	14.0		14.0			
Actuated g/C Ratio		0.73			0.73	0.73	0.16		0.16			
v/c Ratio		0.89			0.28	0.12	0.85		0.31			
Control Delay		20.3			4.6	3.8	65.0		37.7			
Queue Delay		0.0			0.0	0.0	0.0		0.0			
Total Delay		20.3			4.6	3.8	65.0		37.7			
LOS		C			A	A	E		D			
Approach Delay		20.3			4.4							
Approach LOS		C			A							

Lanes, Volumes, Timings
 9: SR 1783 (Upward Rd) & I-26 NB On-Ramp

2011 Base Year - Build 6 Lanes
 Timing Plan: AM Peak



Lane Group	EBL	EBT	EBR	WBL	WBT	WBR	NBL	NBT	NBR	SBL	SBT	SBR
Queue Length 50th (ft)		329			60	17	131		39			
Queue Length 95th (ft)		#590			92	32	#257		81			
Internal Link Dist (ft)		550			242			366			578	
Turn Bay Length (ft)						50	150					
Base Capacity (vph)		829			1366	1096	275		246			
Starvation Cap Reductn		0			0	0	0		0			
Spillback Cap Reductn		0			0	0	0		0			
Storage Cap Reductn		0			0	0	0		0			
Reduced v/c Ratio		0.89			0.28	0.12	0.85		0.31			

Intersection Summary

Area Type: Other
 Cycle Length: 90
 Actuated Cycle Length: 90
 Offset: 9 (10%), Referenced to phase 2:EBTL and 6:WBT, Start of Green
 Natural Cycle: 90
 Control Type: Actuated-Coordinated
 Maximum v/c Ratio: 0.89
 Intersection Signal Delay: 22.7
 Intersection LOS: C
 Intersection Capacity Utilization 77.0%
 ICU Level of Service D
 Analysis Period (min) 15
 # 95th percentile volume exceeds capacity, queue may be longer.
 Queue shown is maximum after two cycles.

Splits and Phases: 9: SR 1783 (Upward Rd) & I-26 NB On-Ramp



Lanes, Volumes, Timings
10: SR 1783 (Upward Rd) & I-26 SB Off-Ramp

2011 Base Year - Build 6 Lanes

Timing Plan: AM Peak



Lane Group	EBL	EBT	EBR	WBL	WBT	WBR	NBL	NBT	NBR	SBL	SBT	SBR
Lane Configurations		↑	↗		↖					↘		↗
Volume (vph)	0	550	205	100	463	0	0	0	0	110	0	454
Ideal Flow (vphpl)	1900	1900	1900	1900	1900	1900	1900	1900	1900	1900	1900	1900
Storage Length (ft)	0		200	0		0	0		0	0		100
Storage Lanes	0		1	0		0	0		0	1		1
Taper Length (ft)	100		100	100		100	100		100	100		100
Lane Util. Factor	1.00	1.00	1.00	1.00	1.00	1.00	1.00	1.00	1.00	1.00	1.00	1.00
Fr _t			0.850									0.850
Fl _t Protected					0.991					0.950		
Satd. Flow (prot)	0	1863	1495	0	1827	0	0	0	0	1770	0	1583
Fl _t Permitted					0.655					0.950		
Satd. Flow (perm)	0	1863	1495	0	1207	0	0	0	0	1770	0	1583
Right Turn on Red			No			No			No			No
Satd. Flow (RTOR)												
Link Speed (mph)		45			45			45			45	
Link Distance (ft)		549			630			547			651	
Travel Time (s)		8.3			9.5			8.3			9.9	
Peak Hour Factor	0.90	0.90	0.90	0.90	0.90	0.90	0.90	0.90	0.90	0.90	0.90	0.90
Heavy Vehicles (%)	5%	2%	8%	8%	2%	5%	5%	5%	5%	2%	5%	2%
Adj. Flow (vph)	0	611	228	111	514	0	0	0	0	122	0	504
Shared Lane Traffic (%)												
Lane Group Flow (vph)	0	611	228	0	625	0	0	0	0	122	0	504
Turn Type			Perm	Perm						Prot		custom
Protected Phases		2			6					4		
Permitted Phases			2	6								4
Detector Phase		2	2	6	6					4		4
Switch Phase												
Minimum Initial (s)		12.0	12.0	12.0	12.0					7.0		7.0
Minimum Split (s)		21.0	21.0	21.0	21.0					14.0		14.0
Total Split (s)	0.0	57.0	57.0	57.0	57.0	0.0	0.0	0.0	0.0	33.0	0.0	33.0
Total Split (%)	0.0%	63.3%	63.3%	63.3%	63.3%	0.0%	0.0%	0.0%	0.0%	36.7%	0.0%	36.7%
Maximum Green (s)		50.0	50.0	50.0	50.0					26.0		26.0
Yellow Time (s)		5.0	5.0	5.0	5.0					5.0		5.0
All-Red Time (s)		2.0	2.0	2.0	2.0					2.0		2.0
Lost Time Adjust (s)	-2.0	-2.0	-2.0	-2.0	-2.0	-2.0	-2.0	-2.0	-2.0	-2.0	-2.0	-2.0
Total Lost Time (s)	2.0	5.0	5.0	5.0	5.0	2.0	2.0	2.0	2.0	5.0	2.0	5.0
Lead/Lag												
Lead-Lag Optimize?												
Vehicle Extension (s)		3.0	3.0	3.0	3.0					3.0		3.0
Recall Mode		C-Max	C-Max	C-Max	C-Max					None		None
Act Effct Green (s)		52.0	52.0		52.0					28.0		28.0
Actuated g/C Ratio		0.58	0.58		0.58					0.31		0.31
v/c Ratio		0.57	0.26		0.90					0.22		1.02
Control Delay		14.5	10.5		31.6					24.3		79.6
Queue Delay		0.0	0.0		0.0					0.0		0.0
Total Delay		14.5	10.5		31.6					24.3		79.6
LOS		B	B		C					C		E
Approach Delay		13.4			31.6							
Approach LOS		B			C							

Lanes, Volumes, Timings
 10: SR 1783 (Upward Rd) & I-26 SB Off-Ramp

2011 Base Year - Build 6 Lanes

Timing Plan: AM Peak



Lane Group	EBL	EBT	EBR	WBL	WBT	WBR	NBL	NBT	NBR	SBL	SBT	SBR
Queue Length 50th (ft)		202	60		344					51		~298
Queue Length 95th (ft)		299	100		m#520					94		#499
Internal Link Dist (ft)		469			550			467			571	
Turn Bay Length (ft)			200									100
Base Capacity (vph)		1076	864		697					551		492
Starvation Cap Reductn		0	0		0					0		0
Spillback Cap Reductn		0	0		0					0		0
Storage Cap Reductn		0	0		0					0		0
Reduced v/c Ratio		0.57	0.26		0.90					0.22		1.02

Intersection Summary

Area Type: Other
 Cycle Length: 90
 Actuated Cycle Length: 90
 Offset: 0 (0%), Referenced to phase 2:EBT and 6:WBTL, Start of Green
 Natural Cycle: 80
 Control Type: Actuated-Coordinated
 Maximum v/c Ratio: 1.02
 Intersection Signal Delay: 35.5
 Intersection LOS: D
 Intersection Capacity Utilization 76.6%
 ICU Level of Service D
 Analysis Period (min) 15
 ~ Volume exceeds capacity, queue is theoretically infinite.
 Queue shown is maximum after two cycles.
 # 95th percentile volume exceeds capacity, queue may be longer.
 Queue shown is maximum after two cycles.
 m Volume for 95th percentile queue is metered by upstream signal.

Splits and Phases: 10: SR 1783 (Upward Rd) & I-26 SB Off-Ramp

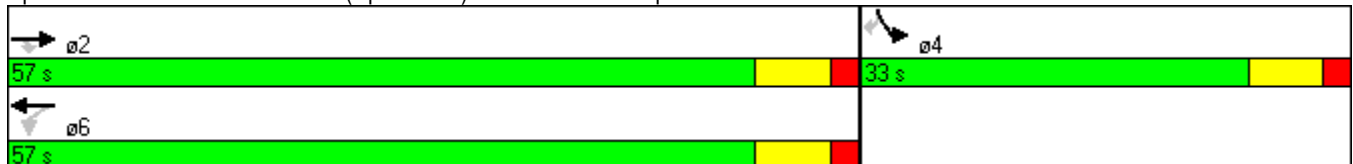

Lanes, Volumes, Timings
1: NC 146 (Long Shoals Rd) & I-26 NB On-Ramp

2011 Base Year - Build 6 Lanes

Timing Plan: PM Peak

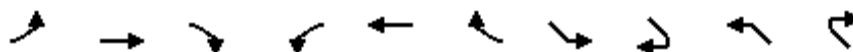

Lane Group	EBL	EBT	EBR2	WBL	WBT	WBR2	SEL	SER2	NWL	NWR2
Lane Configurations										
Volume (vph)	218	602	180	365	452	725	762	172	178	481
Ideal Flow (vphpl)	1900	1900	1900	1900	1900	1900	1900	1900	1900	1900
Grade (%)		3%			-7%					
Storage Length (ft)	450			350			0		675	
Storage Lanes	1			2			2		1	
Taper Length (ft)	100			100			100		100	
Lane Util. Factor	0.97	0.95	1.00	0.97	0.95	1.00	0.97	1.00	0.97	1.00
Frt			0.850			0.850		0.850		0.850
Flt Protected	0.950			0.950			0.950		0.950	
Satd. Flow (prot)	3224	3452	1487	3387	3663	1562	3519	1607	3434	1599
Flt Permitted	0.950			0.950			0.950		0.950	
Satd. Flow (perm)	3224	3452	1487	3387	3663	1562	3519	1607	3434	1599
Right Turn on Red			No			No		No		No
Satd. Flow (RTOR)										
Link Speed (mph)		45			45					
Link Distance (ft)		1009			964					
Travel Time (s)		15.3			14.6					
Peak Hour Factor	0.90	0.90	0.90	0.90	0.90	0.90	0.90	0.90	0.90	0.90
Heavy Vehicles (%)	7%	3%	7%	7%	2%	7%	2%	3%	3%	2%
Adj. Flow (vph)	242	669	200	406	502	806	847	191	198	534
Shared Lane Traffic (%)										
Lane Group Flow (vph)	242	669	200	406	502	806	847	191	198	534
Turn Type	Prot		Free	Prot		Free	Prot	custom	Prot	Free
Protected Phases	5	2		1	6		4		8	
Permitted Phases			Free			Free		4		Free
Detector Phase	5	2		1	6		4	4	8	
Switch Phase										
Minimum Initial (s)	7.0	12.0		7.0	12.0		7.0	7.0	7.0	
Minimum Split (s)	16.0	20.0		15.0	21.0		16.0	16.0	15.0	
Total Split (s)	16.0	49.0	0.0	23.0	56.0	0.0	28.0	28.0	28.0	0.0
Total Split (%)	16.0%	49.0%	0.0%	23.0%	56.0%	0.0%	28.0%	28.0%	28.0%	0.0%
Maximum Green (s)	7.8	41.5		15.3	47.0		19.9	19.9	20.0	
Yellow Time (s)	3.4	4.3		4.0	5.2		3.8	3.8	3.7	
All-Red Time (s)	4.8	3.2		3.7	3.8		4.3	4.3	4.3	
Lost Time Adjust (s)	-3.2	-2.5	-2.5	-2.7	-4.0	-4.0	-3.1	-3.1	-3.0	0.0
Total Lost Time (s)	5.0	5.0	1.5	5.0	5.0	0.0	5.0	5.0	5.0	4.0
Lead/Lag	Lead	Lag		Lead	Lag					
Lead-Lag Optimize?	Yes	Yes		Yes	Yes					
Vehicle Extension (s)	2.0	6.0		2.0	6.0		2.0	2.0	2.0	
Minimum Gap (s)	3.0	3.0		3.0	3.0		3.0	3.0	3.0	
Time Before Reduce (s)	0.0	15.0		0.0	15.0		0.0	0.0	0.0	
Time To Reduce (s)	0.0	30.0		0.0	30.0		0.0	0.0	0.0	
Recall Mode	None	C-Max		None	C-Max		None	None	None	
Act Effct Green (s)	11.0	44.9	100.0	17.1	51.0	100.0	23.0	23.0	23.0	100.0
Actuated g/C Ratio	0.11	0.45	1.00	0.17	0.51	1.00	0.23	0.23	0.23	1.00
v/c Ratio	0.68	0.43	0.13	0.70	0.27	0.52	1.05	0.52	0.25	0.33
Control Delay	53.4	20.1	0.2	46.0	14.4	1.2	83.0	39.4	32.5	0.6
Queue Delay	0.0	0.0	0.0	0.0	0.0	0.0	0.0	0.0	0.0	0.0

Lanes, Volumes, Timings
 1: NC 146 (Long Shoals Rd) & I-26 NB On-Ramp

2011 Base Year - Build 6 Lanes

Timing Plan: PM Peak

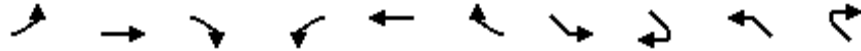

Lane Group	EBL	EBT	EBR2	WBL	WBT	WBR2	SEL	SER2	NWL	NWR2
Total Delay	53.4	20.1	0.2	46.0	14.4	1.2	83.0	39.4	32.5	0.6
LOS	D	C	A	D	B	A	F	D	C	A
Approach Delay	23.8			15.7						
Approach LOS	C			B						
Queue Length 50th (ft)	77	151	0	125	91	0	~304	107	53	0
Queue Length 95th (ft)	#119	200	0	176	124	0	#423	178	84	0
Internal Link Dist (ft)	929			884						
Turn Bay Length (ft)	450		300	350		300		425	675	575
Base Capacity (vph)	355	1550	1487	610	1868	1562	809	370	790	1599
Starvation Cap Reductn	0	0	0	0	0	0	0	0	0	0
Spillback Cap Reductn	0	0	0	0	0	0	0	0	0	0
Storage Cap Reductn	0	0	0	0	0	0	0	0	0	0
Reduced v/c Ratio	0.68	0.43	0.13	0.67	0.27	0.52	1.05	0.52	0.25	0.33

Intersection Summary

Area Type: Other
 Cycle Length: 100
 Actuated Cycle Length: 100
 Offset: 0 (0%), Referenced to phase 2:EBT and 6:WBT, Start of Green
 Natural Cycle: 60
 Control Type: Actuated-Coordinated
 Maximum v/c Ratio: 1.05
 Intersection Signal Delay: 30.0
 Intersection LOS: C
 Intersection Capacity Utilization 61.3%
 ICU Level of Service B
 Analysis Period (min) 15
 ~ Volume exceeds capacity, queue is theoretically infinite.
 Queue shown is maximum after two cycles.
 # 95th percentile volume exceeds capacity, queue may be longer.
 Queue shown is maximum after two cycles.

Splits and Phases: 1: NC 146 (Long Shoals Rd) & I-26 NB On-Ramp

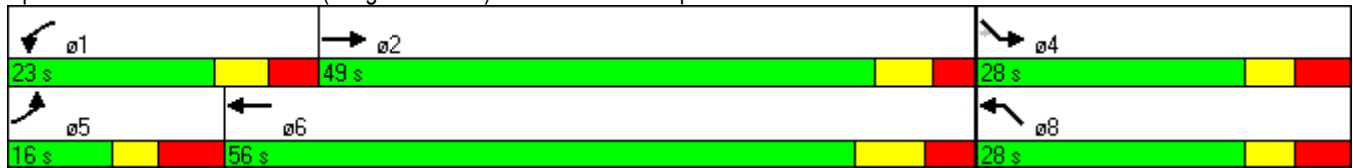

Lanes, Volumes, Timings
2: I-26 NB On-Ramp & US 25 (Asheville Highway)

2011 Base Year - Build 6 Lanes

Timing Plan: PM Peak



Lane Group	EBL	EBT	EBR	WBL	WBT	WBR	NBL	NBT	NBR	SBL	SBT	SBR
Lane Configurations				↙		↗	↗	↗			↗	↗
Volume (vph)	0	0	0	107	0	419	602	1052	0	0	976	235
Ideal Flow (vphpl)	1900	1900	1900	1900	1900	1900	1900	1900	1900	1900	1900	1900
Grade (%)		0%			2%			-1%			2%	
Storage Length (ft)	0		0	0		150	0		0	0		300
Storage Lanes	0		0	1		2	1		0	0		1
Taper Length (ft)	100		100	100		100	100		100	100		100
Lane Util. Factor	1.00	1.00	1.00	1.00	1.00	0.88	1.00	0.95	1.00	1.00	0.95	1.00
Frt						0.850						0.850
Flt Protected				0.950			0.950					
Satd. Flow (prot)	0	0	0	1735	0	2706	1680	3489	0	0	3436	1480
Flt Permitted				0.950			0.950					
Satd. Flow (perm)	0	0	0	1735	0	2706	1680	3489	0	0	3436	1480
Right Turn on Red			No			No			No			No
Satd. Flow (RTOR)												
Link Speed (mph)		45			35			45			45	
Link Distance (ft)		533			612			601			596	
Travel Time (s)		8.1			11.9			9.1			9.0	
Peak Hour Factor	0.90	0.90	0.90	0.90	0.90	0.90	0.90	0.90	0.90	0.90	0.90	0.90
Heavy Vehicles (%)	5%	5%	5%	3%	5%	4%	8%	4%	5%	5%	4%	8%
Adj. Flow (vph)	0	0	0	119	0	466	669	1169	0	0	1084	261
Shared Lane Traffic (%)												
Lane Group Flow (vph)	0	0	0	119	0	466	669	1169	0	0	1084	261
Turn Type				Prot		custom	Prot					Free
Protected Phases				4			5	2			6	
Permitted Phases						4						Free
Detector Phase				4		4	5	2			6	
Switch Phase												
Minimum Initial (s)				7.0		7.0	7.0	12.0			12.0	
Minimum Split (s)				13.0		13.0	14.0	19.0			18.0	
Total Split (s)	0.0	0.0	0.0	21.0	0.0	21.0	43.0	79.0	0.0	0.0	36.0	0.0
Total Split (%)	0.0%	0.0%	0.0%	21.0%	0.0%	21.0%	43.0%	79.0%	0.0%	0.0%	36.0%	0.0%
Maximum Green (s)				15.0		15.0	36.6	72.9			30.7	
Yellow Time (s)				3.7		3.7	3.0	4.6			4.3	
All-Red Time (s)				2.3		2.3	3.4	1.5			1.0	
Lost Time Adjust (s)	0.0	0.0	-2.0	-2.0	0.0	-2.0	-1.4	-1.1	0.0	-2.0	-0.3	0.0
Total Lost Time (s)	4.0	4.0	2.0	4.0	4.0	4.0	5.0	5.0	4.0	2.0	5.0	4.0
Lead/Lag							Lag				Lead	
Lead-Lag Optimize?							Yes				Yes	
Vehicle Extension (s)				2.0		2.0	2.0	8.0			8.0	
Minimum Gap (s)				3.0		3.0	3.0	5.5			5.5	
Time Before Reduce (s)				0.0		0.0	0.0	15.0			15.0	
Time To Reduce (s)				0.0		0.0	0.0	50.0			50.0	
Recall Mode				None		None	None	C-Max			C-Max	
Act Effct Green (s)				17.0		17.0	38.0	74.0			31.0	100.0
Actuated g/C Ratio				0.17		0.17	0.38	0.74			0.31	1.00
v/c Ratio				0.40		1.01	1.05	0.45			1.02	0.18
Control Delay				41.7		87.6	49.8	0.4			67.2	0.3
Queue Delay				0.0		0.0	0.0	0.3			0.0	0.0

Lanes, Volumes, Timings
 2: I-26 NB On-Ramp & US 25 (Asheville Highway)

2011 Base Year - Build 6 Lanes

Timing Plan: PM Peak



Lane Group	EBL	EBT	EBR	WBL	WBT	WBR	NBL	NBT	NBR	SBL	SBT	SBR
Total Delay				41.7		87.6	49.8	0.7			67.2	0.3
LOS				D		F	D	A			E	A
Approach Delay								18.6			54.2	
Approach LOS								B			D	
Queue Length 50th (ft)				68		~173	~487	5			~374	0
Queue Length 95th (ft)				124		#288	m#487	m3			#516	0
Internal Link Dist (ft)		453			532			521			516	
Turn Bay Length (ft)						150						300
Base Capacity (vph)				295		460	638	2582			1065	1480
Starvation Cap Reductn				0		0	0	683			0	0
Spillback Cap Reductn				0		0	0	0			0	0
Storage Cap Reductn				0		0	0	0			0	0
Reduced v/c Ratio				0.40		1.01	1.05	0.62			1.02	0.18

Intersection Summary

Area Type: Other
 Cycle Length: 100
 Actuated Cycle Length: 100
 Offset: 91 (91%), Referenced to phase 2:NBT and 6:SBT, Start of Green
 Natural Cycle: 110
 Control Type: Actuated-Coordinated
 Maximum v/c Ratio: 1.05
 Intersection Signal Delay: 40.6
 Intersection LOS: D
 Intersection Capacity Utilization 83.2%
 ICU Level of Service E
 Analysis Period (min) 15
 ~ Volume exceeds capacity, queue is theoretically infinite.
 Queue shown is maximum after two cycles.
 # 95th percentile volume exceeds capacity, queue may be longer.
 Queue shown is maximum after two cycles.
 m Volume for 95th percentile queue is metered by upstream signal.

Splits and Phases: 2: I-26 NB On-Ramp & US 25 (Asheville Highway)

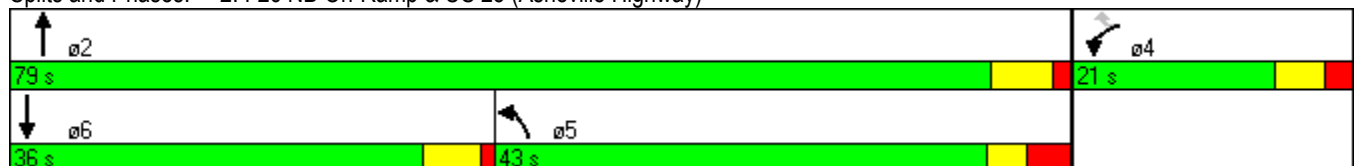

Lanes, Volumes, Timings
 3: I-26 SB Off-Ramp & US 25 (Asheville Highway)

2011 Base Year - Build 6 Lanes

Timing Plan: PM Peak



Lane Group	EBL	EBT	EBR	WBL	WBT	WBR	NBL	NBT	NBR	SBL	SBT	SBR
Lane Configurations												
Volume (vph)	239	0	487	0	0	0	0	1415	107	332	751	0
Ideal Flow (vphpl)	1900	1900	1900	1900	1900	1900	1900	1900	1900	1900	1900	1900
Grade (%)		3%			0%			4%			1%	
Storage Length (ft)	0		100	0		0	0		500	0		0
Storage Lanes	1		1	0		0	0		1	1		0
Taper Length (ft)	100		100	100		100	100		100	100		100
Lane Util. Factor	1.00	1.00	1.00	1.00	1.00	1.00	1.00	0.95	1.00	1.00	0.95	1.00
Frt			0.850						0.850			
Flt Protected	0.950									0.950		
Satd. Flow (prot)	1710	0	1544	0	0	0	0	3435	1465	1663	3487	0
Flt Permitted	0.950									0.950		
Satd. Flow (perm)	1710	0	1544	0	0	0	0	3435	1465	1663	3487	0
Right Turn on Red			Yes			No			No			No
Satd. Flow (RTOR)			236									
Link Speed (mph)		35			45			45			45	
Link Distance (ft)		471			598			795			601	
Travel Time (s)		9.2			9.1			12.0			9.1	
Peak Hour Factor	0.90	0.90	0.90	0.90	0.90	0.90	0.90	0.90	0.90	0.90	0.90	0.90
Heavy Vehicles (%)	4%	5%	3%	5%	5%	5%	5%	3%	8%	8%	3%	5%
Adj. Flow (vph)	266	0	541	0	0	0	0	1572	119	369	834	0
Shared Lane Traffic (%)												
Lane Group Flow (vph)	266	0	541	0	0	0	0	1572	119	369	834	0
Turn Type	Prot		custom						Free	Prot		
Protected Phases	4		4					2		1	6	
Permitted Phases									Free			
Detector Phase	4		4					2		1	6	
Switch Phase												
Minimum Initial (s)	7.0		7.0					12.0		7.0	12.0	
Minimum Split (s)	14.0		14.0					19.0		14.0	19.0	
Total Split (s)	25.0	0.0	25.0	0.0	0.0	0.0	0.0	49.0	0.0	26.0	75.0	0.0
Total Split (%)	25.0%	0.0%	25.0%	0.0%	0.0%	0.0%	0.0%	49.0%	0.0%	26.0%	75.0%	0.0%
Maximum Green (s)	19.0		19.0					43.3		19.5	69.3	
Yellow Time (s)	4.0		4.0					4.7		4.0	4.7	
All-Red Time (s)	2.0		2.0					1.0		2.5	1.0	
Lost Time Adjust (s)	-1.0	-2.0	-1.0	-2.0	-2.0	-2.0	-2.0	-0.7	-0.7	-1.5	-1.7	-2.0
Total Lost Time (s)	5.0	2.0	5.0	2.0	2.0	2.0	2.0	5.0	3.3	5.0	4.0	2.0
Lead/Lag								Lead		Lag		
Lead-Lag Optimize?								Yes		Yes		
Vehicle Extension (s)	2.0		2.0					8.0		2.0	8.0	
Minimum Gap (s)	3.0		3.0					5.5		3.0	5.5	
Time Before Reduce (s)	0.0		0.0					15.0		0.0	15.0	
Time To Reduce (s)	0.0		0.0					50.0		0.0	50.0	
Recall Mode	None		None					C-Max		None	C-Max	
Act Effct Green (s)	20.0		20.0					44.0	100.0	21.0	71.0	
Actuated g/C Ratio	0.20		0.20					0.44	1.00	0.21	0.71	
v/c Ratio	0.78		1.09					1.04	0.08	1.06	0.34	
Control Delay	54.9		88.8					63.0	0.1	89.5	2.3	
Queue Delay	0.0		0.0					0.0	0.0	0.0	0.0	

Lanes, Volumes, Timings
 3: I-26 SB Off-Ramp & US 25 (Asheville Highway)

2011 Base Year - Build 6 Lanes

Timing Plan: PM Peak



Lane Group	EBL	EBT	EBR	WBL	WBT	WBR	NBL	NBT	NBR	SBL	SBT	SBR
Total Delay	54.9		88.8					63.0	0.1	89.5	2.3	
LOS	D		F					E	A	F	A	
Approach Delay								58.6			29.1	
Approach LOS								E			C	
Queue Length 50th (ft)	162		~260					~573	0	~270	30	
Queue Length 95th (ft)	#284		#468					#710	0	m#281	m30	
Internal Link Dist (ft)		391			518			715				521
Turn Bay Length (ft)			100						500			
Base Capacity (vph)	342		498					1511	1465	349	2476	
Starvation Cap Reductn	0		0					0	0	0	0	
Spillback Cap Reductn	0		0					0	0	0	0	
Storage Cap Reductn	0		0					0	0	0	0	
Reduced v/c Ratio	0.78		1.09					1.04	0.08	1.06	0.34	

Intersection Summary

Area Type: Other
 Cycle Length: 100
 Actuated Cycle Length: 100
 Offset: 0 (0%), Referenced to phase 2:NBT and 6:SBT, Start of Green
 Natural Cycle: 120
 Control Type: Actuated-Coordinated
 Maximum v/c Ratio: 1.09
 Intersection Signal Delay: 53.2
 Intersection LOS: D
 Intersection Capacity Utilization 83.2%
 ICU Level of Service E
 Analysis Period (min) 15
 ~ Volume exceeds capacity, queue is theoretically infinite.
 Queue shown is maximum after two cycles.
 # 95th percentile volume exceeds capacity, queue may be longer.
 Queue shown is maximum after two cycles.
 m Volume for 95th percentile queue is metered by upstream signal.



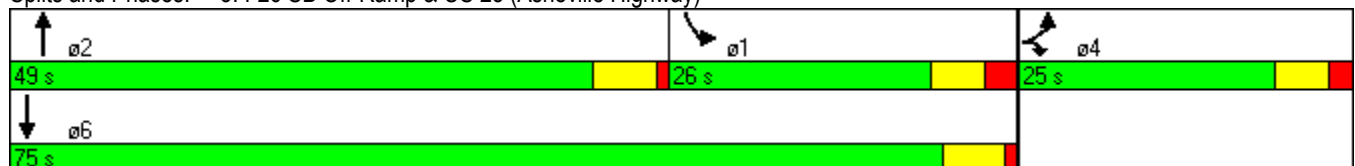



















Splits and Phases: 3: I-26 SB Off-Ramp & US 25 (Asheville Highway)



Lanes, Volumes, Timings
6: US 64 & SR 1516 (Francis Rd)

2011 Base Year - Build 6 Lanes

Timing Plan: PM Peak

												
Lane Group	EBL	EBT	EBR	WBL	WBT	WBR	NBL	NBT	NBR	SBL	SBT	SBR
Lane Configurations												
Volume (vph)	109	1895	343	57	1494	18	386	5	82	26	5	122
Ideal Flow (vphpl)	1900	1900	1900	1900	1900	1900	1900	1900	1900	1900	1900	1900
Grade (%)		-1%			4%			-1%			2%	
Storage Length (ft)	150		0	125		0	150		150	0		150
Storage Lanes	1		1	1		0	1		1	0		1
Taper Length (ft)	100		100	100		100	100		100	100		100
Lane Util. Factor	1.00	0.95	1.00	1.00	0.95	0.95	0.95	0.95	1.00	1.00	1.00	1.00
Frt			0.850		0.998				0.850			0.850
Flt Protected	0.950			0.950			0.950	0.954			0.960	
Satd. Flow (prot)	1778	3557	1591	1734	3461	0	1690	1697	1591	0	1770	1567
Flt Permitted	0.950			0.950			0.950	0.954			0.960	
Satd. Flow (perm)	1778	3557	1591	1734	3461	0	1690	1697	1591	0	1770	1567
Right Turn on Red			No			No			No			No
Satd. Flow (RTOR)												
Link Speed (mph)		45			45			35			35	
Link Distance (ft)		836			622			375			406	
Travel Time (s)		12.7			9.4			7.3			7.9	
Peak Hour Factor	0.90	0.90	0.90	0.90	0.90	0.90	0.90	0.90	0.90	0.90	0.90	0.90
Heavy Vehicles (%)	2%	2%	2%	2%	2%	2%	2%	2%	2%	2%	2%	2%
Adj. Flow (vph)	121	2106	381	63	1660	20	429	6	91	29	6	136
Shared Lane Traffic (%)							49%					
Lane Group Flow (vph)	121	2106	381	63	1680	0	219	216	91	0	35	136
Turn Type	Prot		Perm	Prot			Split		pm+ov	Split		pm+ov
Protected Phases	5	2		1	6		4	4	1	3	3	5
Permitted Phases			2						4			3
Detector Phase	5	2	2	1	6		4	4	1	3	3	5
Switch Phase												
Minimum Initial (s)	7.0	12.0	12.0	7.0	12.0		7.0	7.0	7.0	7.0	7.0	7.0
Minimum Split (s)	13.0	18.0	18.0	13.0	18.0		14.0	14.0	13.0	14.0	14.0	13.0
Total Split (s)	18.0	97.0	97.0	13.0	92.0	0.0	26.0	26.0	13.0	14.0	14.0	18.0
Total Split (%)	12.0%	64.7%	64.7%	8.7%	61.3%	0.0%	17.3%	17.3%	8.7%	9.3%	9.3%	12.0%
Maximum Green (s)	12.4	91.0	91.0	7.6	86.4		19.4	19.4	7.6	7.5	7.5	12.4
Yellow Time (s)	3.2	4.6	4.6	3.0	4.2		3.9	3.9	3.0	3.7	3.7	3.2
All-Red Time (s)	2.4	1.4	1.4	2.4	1.4		2.7	2.7	2.4	2.8	2.8	2.4
Lost Time Adjust (s)	-0.6	-1.0	-1.0	-0.4	-0.6	-2.0	-1.6	-1.6	-0.4	-2.0	-1.5	-0.6
Total Lost Time (s)	5.0	5.0	5.0	5.0	5.0	2.0	5.0	5.0	5.0	4.5	5.0	5.0
Lead/Lag	Lead	Lag	Lag	Lead	Lag		Lag	Lag	Lead	Lead	Lead	Lead
Lead-Lag Optimize?	Yes	Yes	Yes	Yes	Yes		Yes	Yes	Yes	Yes	Yes	Yes
Vehicle Extension (s)	1.0	2.0	2.0	1.0	2.0		1.0	1.0	1.0	1.0	1.0	1.0
Recall Mode	None	C-Max	C-Max	None	C-Max		None	None	None	None	None	None
Act Effct Green (s)	12.4	95.2	95.2	7.9	90.7		20.9	20.9	33.8		8.7	19.4
Actuated g/C Ratio	0.08	0.63	0.63	0.05	0.60		0.14	0.14	0.23		0.06	0.13
v/c Ratio	0.82	0.93	0.38	0.69	0.80		0.93	0.91	0.25		0.34	0.67
Control Delay	112.3	24.8	10.4	105.2	27.7		105.7	102.5	49.9		77.3	62.2
Queue Delay	0.0	0.0	0.0	0.0	0.0		0.0	0.0	0.0		0.0	0.0
Total Delay	112.3	24.8	10.4	105.2	27.7		105.7	102.5	49.9		77.3	62.2
LOS	F	C	B	F	C		F	F	D		E	E
Approach Delay		26.8			30.5			94.7			65.3	

Lanes, Volumes, Timings
6: US 64 & SR 1516 (Francis Rd)

2011 Base Year - Build 6 Lanes

Timing Plan: PM Peak



Lane Group	EBL	EBT	EBR	WBL	WBT	WBR	NBL	NBT	NBR	SBL	SBT	SBR
Approach LOS	C			C			F			E		
Queue Length 50th (ft)	124	762	101	62	680		225	222	73		34	94
Queue Length 95th (ft)	#230	#1206	141	#137	790		#396	#389	128		73	151
Internal Link Dist (ft)	756			542			295			326		
Turn Bay Length (ft)	150			125			150		150			150
Base Capacity (vph)	154	2258	1010	92	2093		239	240	360		106	209
Starvation Cap Reductn	0	0	0	0	0		0	0	0		0	0
Spillback Cap Reductn	0	0	0	0	0		0	0	0		0	0
Storage Cap Reductn	0	0	0	0	0		0	0	0		0	0
Reduced v/c Ratio	0.79	0.93	0.38	0.68	0.80		0.92	0.90	0.25		0.33	0.65

Intersection Summary

Area Type: Other
 Cycle Length: 150
 Actuated Cycle Length: 150
 Offset: 19 (13%), Referenced to phase 2:EBT and 6:WBT, Start of Green
 Natural Cycle: 130
 Control Type: Actuated-Coordinated
 Maximum v/c Ratio: 0.93
 Intersection Signal Delay: 36.4
 Intersection LOS: D
 Intersection Capacity Utilization 88.2%
 ICU Level of Service E
 Analysis Period (min) 15
 # 95th percentile volume exceeds capacity, queue may be longer.
 Queue shown is maximum after two cycles.

Splits and Phases: 6: US 64 & SR 1516 (Francis Rd)

ø1 13 s	ø2 97 s	ø3 14 s	ø4 26 s
ø5 18 s	ø6 92 s		

Lanes, Volumes, Timings
7: US 64 & I-26 SB Off-Ramp

2011 Base Year - Build 6 Lanes

Timing Plan: PM Peak

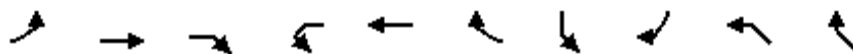

Lane Group	EBL	EBT	EBR	WBL	WBT	WBR	SBL	SBR	NWL	NWR
Lane Configurations		↑↑	↑		↑↑			↑↑		
Volume (vph)	0	1885	225	0	1366	0	0	337	0	0
Ideal Flow (vphpl)	1900	1900	1900	1900	1900	1900	1900	1900	1900	1900
Grade (%)		3%			-3%		-3%		0%	
Storage Length (ft)	0		0	0		0	0	500	0	0
Storage Lanes	0		1	0		0	0	1	0	0
Taper Length (ft)	100		100	100		100	100	100	100	100
Lane Util. Factor	1.00	0.95	1.00	1.00	0.95	1.00	1.00	0.88	1.00	1.00
Frt			0.850					0.850		
Flt Protected										
Satd. Flow (prot)	0	3486	1473	0	3592	0	0	2828	0	0
Flt Permitted										
Satd. Flow (perm)	0	3486	1473	0	3592	0	0	2828	0	0
Right Turn on Red			No			No		No		
Satd. Flow (RTOR)										
Link Speed (mph)		45			45		35		45	
Link Distance (ft)		728			745		807		350	
Travel Time (s)		11.0			11.3		15.7		5.3	
Peak Hour Factor	0.90	0.90	0.90	0.90	0.90	0.90	0.90	0.90	0.90	0.90
Heavy Vehicles (%)	5%	2%	8%	5%	2%	5%	5%	2%	5%	5%
Adj. Flow (vph)	0	2094	250	0	1518	0	0	374	0	0
Shared Lane Traffic (%)										
Lane Group Flow (vph)	0	2094	250	0	1518	0	0	374	0	0
Turn Type			Perm					custom		
Protected Phases		Free			6			4		
Permitted Phases			Free							
Detector Phase					6			4		
Switch Phase										
Minimum Initial (s)					12.0			7.0		
Minimum Split (s)					18.0			13.0		
Total Split (s)	0.0	0.0	0.0	0.0	107.0	0.0	0.0	43.0	0.0	0.0
Total Split (%)	0.0%	0.0%	0.0%	0.0%	71.3%	0.0%	0.0%	28.7%	0.0%	0.0%
Maximum Green (s)					101.2			37.9		
Yellow Time (s)					4.8			4.1		
All-Red Time (s)					1.0			1.0		
Lost Time Adjust (s)	0.0	0.0	0.0	0.0	-0.8	0.0	0.0	-0.1	-2.0	0.0
Total Lost Time (s)	4.0	4.0	4.0	4.0	5.0	4.0	4.0	5.0	2.0	4.0
Lead/Lag										
Lead-Lag Optimize?										
Vehicle Extension (s)					2.0			1.0		
Recall Mode					C-Max			None		
Act Effct Green (s)		150.0	150.0		116.4			23.6		
Actuated g/C Ratio		1.00	1.00		0.78			0.16		
v/c Ratio		0.60	0.17		0.54			0.84		
Control Delay		0.2	0.1		8.7			78.2		
Queue Delay		0.0	0.0		0.0			0.0		
Total Delay		0.2	0.1		8.7			78.2		
LOS		A	A		A			E		
Approach Delay		0.2			8.7					

Lanes, Volumes, Timings
 7: US 64 & I-26 SB Off-Ramp

2011 Base Year - Build 6 Lanes

Timing Plan: PM Peak

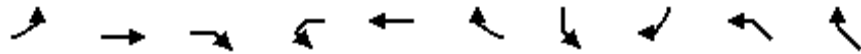

Lane Group	EBL	EBT	EBR	WBL	WBT	WBR	SBL	SBR	NWL	NWR
Approach LOS		A			A					
Queue Length 50th (ft)		0	0		266			204		
Queue Length 95th (ft)		m0	m0		367			257		
Internal Link Dist (ft)		648			665		727		270	
Turn Bay Length (ft)								500		
Base Capacity (vph)		3486	1473		2788			716		
Starvation Cap Reductn		0	0		0			0		
Spillback Cap Reductn		0	0		0			0		
Storage Cap Reductn		0	0		0			0		
Reduced v/c Ratio		0.60	0.17		0.54			0.52		

Intersection Summary

Area Type: Other

Cycle Length: 150

Actuated Cycle Length: 150

Offset: 0 (0%), Referenced to phase 6:WBT, Start of Green, Master Intersection

Natural Cycle: 45

Control Type: Actuated-Coordinated

Maximum v/c Ratio: 0.84

Intersection Signal Delay: 10.1

Intersection LOS: B

Intersection Capacity Utilization 92.8%

ICU Level of Service F

Analysis Period (min) 15

m Volume for 95th percentile queue is metered by upstream signal.

Splits and Phases: 7: US 64 & I-26 SB Off-Ramp



Lanes, Volumes, Timings
8: US 64 & SR 1634 (Carolina Village Rd)

2011 Base Year - Build 6 Lanes

Timing Plan: PM Peak



Lane Group	EBL	EBT	EBR	WBL	WBT	WBR	NBL	NBT	NBR	SBL	SBT	SBR
Lane Configurations												
Volume (vph)	79	1834	66	112	1484	123	70	15	146	111	10	58
Ideal Flow (vphpl)	1900	1900	1900	1900	1900	1900	1900	1900	1900	1900	1900	1900
Grade (%)		1%			-3%			3%				-1%
Storage Length (ft)	100		0	100		0	0		0	0		150
Storage Lanes	1		0	1		1	0		0	0		1
Taper Length (ft)	100		100	100		100	100		100	100		100
Lane Util. Factor	1.00	0.95	0.95	1.00	0.95	1.00	1.00	1.00	1.00	1.00	1.00	1.00
Frt		0.995				0.850		0.915				0.850
Flt Protected	0.950			0.950				0.985			0.956	
Satd. Flow (prot)	1761	3504	0	1796	3592	1607	0	1654	0	0	1790	1591
Flt Permitted	0.950			0.950				0.724			0.431	
Satd. Flow (perm)	1761	3504	0	1796	3592	1607	0	1215	0	0	807	1591
Right Turn on Red			No			No			No			No
Satd. Flow (RTOR)												
Link Speed (mph)		45			45			30			30	
Link Distance (ft)		560			728			219			359	
Travel Time (s)		8.5			11.0			5.0			8.2	
Peak Hour Factor	0.90	0.90	0.90	0.90	0.90	0.90	0.90	0.90	0.90	0.90	0.90	0.90
Heavy Vehicles (%)	2%	2%	2%	2%	2%	2%	2%	2%	2%	2%	2%	2%
Adj. Flow (vph)	88	2038	73	124	1649	137	78	17	162	123	11	64
Shared Lane Traffic (%)												
Lane Group Flow (vph)	88	2111	0	124	1649	137	0	257	0	0	134	64
Turn Type	Prot			Prot		Perm	Perm			Perm		pm+ov
Protected Phases	5	2		1	6			8			4	5
Permitted Phases						6	8			4		4
Detector Phase	5	2		1	6	6	8	8		4	4	5
Switch Phase												
Minimum Initial (s)	7.0	12.0		7.0	12.0	12.0	7.0	7.0		7.0	7.0	7.0
Minimum Split (s)	13.0	18.0		13.0	19.0	19.0	13.0	13.0		13.0	13.0	13.0
Total Split (s)	20.0	98.0	0.0	16.0	94.0	94.0	36.0	36.0	0.0	36.0	36.0	20.0
Total Split (%)	13.3%	65.3%	0.0%	10.7%	62.7%	62.7%	24.0%	24.0%	0.0%	24.0%	24.0%	13.3%
Maximum Green (s)	14.1	92.4		10.6	87.8	87.8	30.2	30.2		30.1	30.1	14.1
Yellow Time (s)	3.0	4.4		3.0	4.8	4.8	3.4	3.4		3.6	3.6	3.0
All-Red Time (s)	2.9	1.2		2.4	1.4	1.4	2.4	2.4		2.3	2.3	2.9
Lost Time Adjust (s)	-0.9	-0.6	-2.0	-0.4	-1.2	-1.2	-2.0	-0.8	-2.0	-2.0	-0.9	-0.9
Total Lost Time (s)	5.0	5.0	2.0	5.0	5.0	5.0	3.8	5.0	2.0	3.9	5.0	5.0
Lead/Lag	Lag	Lag		Lead	Lead	Lead						Lag
Lead-Lag Optimize?	Yes	Yes		Yes	Yes	Yes						Yes
Vehicle Extension (s)	1.0	2.0		1.0	2.0	2.0	1.0	1.0		1.0	1.0	1.0
Recall Mode	None	C-Max		None	C-Max	C-Max	None	None		None	None	None
Act Effct Green (s)	15.0	93.0		11.0	89.0	89.0		31.0			31.0	51.0
Actuated g/C Ratio	0.10	0.62		0.07	0.59	0.59		0.21			0.21	0.34
v/c Ratio	0.50	0.97		0.94	0.77	0.14		1.02			0.80	0.12
Control Delay	74.5	41.2		127.5	17.7	9.3		120.3			89.4	34.9
Queue Delay	0.0	0.0		0.0	0.4	0.0		0.0			0.0	0.0
Total Delay	74.5	41.2		127.5	18.1	9.3		120.3			89.4	34.9
LOS	E	D		F	B	A		F			F	C
Approach Delay		42.5			24.6			120.3			71.8	

Lanes, Volumes, Timings
 8: US 64 & SR 1634 (Carolina Village Rd)

2011 Base Year - Build 6 Lanes

Timing Plan: PM Peak



Lane Group	EBL	EBT	EBR	WBL	WBT	WBR	NBL	NBT	NBR	SBL	SBT	SBR
Approach LOS	D			C			F			E		
Queue Length 50th (ft)	83	990		122	521	42		~267		126	43	
Queue Length 95th (ft)	145	#1224		#260	495	68		#449		#245	80	
Internal Link Dist (ft)		480			648			139			279	
Turn Bay Length (ft)	100			100								150
Base Capacity (vph)	176	2172		132	2131	953		251		167	541	
Starvation Cap Reductn	0	0		0	131	0		0		0	0	
Spillback Cap Reductn	0	0		0	0	0		0		0	0	
Storage Cap Reductn	0	0		0	0	0		0		0	0	
Reduced v/c Ratio	0.50	0.97		0.94	0.82	0.14		1.02		0.80	0.12	

Intersection Summary

Area Type: Other
 Cycle Length: 150
 Actuated Cycle Length: 150
 Offset: 118 (79%), Referenced to phase 2:EBT and 6:WBT, Start of Green
 Natural Cycle: 110
 Control Type: Actuated-Coordinated
 Maximum v/c Ratio: 1.02
 Intersection Signal Delay: 40.6
 Intersection LOS: D
 Intersection Capacity Utilization 91.8%
 ICU Level of Service F
 Analysis Period (min) 15
 ~ Volume exceeds capacity, queue is theoretically infinite.
 Queue shown is maximum after two cycles.
 # 95th percentile volume exceeds capacity, queue may be longer.
 Queue shown is maximum after two cycles.

Splits and Phases: 8: US 64 & SR 1634 (Carolina Village Rd)



Lanes, Volumes, Timings
 9: SR 1783 (Upward Rd) & I-26 NB On-Ramp

2011 Base Year - Build 6 Lanes

Timing Plan: PM Peak



Lane Group	EBL	EBT	EBR	WBL	WBT	WBR	NBL	NBT	NBR	SBL	SBT	SBR
Lane Configurations		↕			↑	↗	↗		↗			
Volume (vph)	454	367	0	0	261	110	205	0	89	0	0	0
Ideal Flow (vphpl)	1900	1900	1900	1900	1900	1900	1900	1900	1900	1900	1900	1900
Storage Length (ft)	0		0	0		50	150		0	0		0
Storage Lanes	0		0	0		1	1		1	0		0
Taper Length (ft)	100		100	100		100	100		100	100		100
Lane Util. Factor	1.00	1.00	1.00	1.00	1.00	1.00	1.00	1.00	1.00	1.00	1.00	1.00
Fr _t						0.850			0.850			
Fl _t Protected		0.973					0.950					
Satd. Flow (prot)	0	1755	0	0	1863	1495	1770	0	1583	0	0	0
Fl _t Permitted		0.677					0.950					
Satd. Flow (perm)	0	1221	0	0	1863	1495	1770	0	1583	0	0	0
Right Turn on Red			No			No			No			No
Satd. Flow (RTOR)												
Link Speed (mph)		45			45			45				45
Link Distance (ft)		630			322			446				658
Travel Time (s)		9.5			4.9			6.8				10.0
Peak Hour Factor	0.90	0.90	0.90	0.90	0.90	0.90	0.90	0.90	0.90	0.90	0.90	0.90
Heavy Vehicles (%)	8%	2%	5%	5%	2%	8%	2%	5%	2%	5%	5%	5%
Adj. Flow (vph)	504	408	0	0	290	122	228	0	99	0	0	0
Shared Lane Traffic (%)												
Lane Group Flow (vph)	0	912	0	0	290	122	228	0	99	0	0	0
Turn Type	Perm					Perm	Prot		custom			
Protected Phases		2			6		8					
Permitted Phases	2					6			8			
Detector Phase	2	2			6	6	8		8			
Switch Phase												
Minimum Initial (s)	12.0	12.0			12.0	12.0	7.0		7.0			
Minimum Split (s)	21.0	21.0			21.0	21.0	14.0		14.0			
Total Split (s)	74.0	74.0	0.0	0.0	74.0	74.0	16.0	0.0	16.0	0.0	0.0	0.0
Total Split (%)	82.2%	82.2%	0.0%	0.0%	82.2%	82.2%	17.8%	0.0%	17.8%	0.0%	0.0%	0.0%
Maximum Green (s)	67.0	67.0			67.0	67.0	9.0		9.0			
Yellow Time (s)	5.0	5.0			5.0	5.0	5.0		5.0			
All-Red Time (s)	2.0	2.0			2.0	2.0	2.0		2.0			
Lost Time Adjust (s)	-2.0	-2.0	-2.0	-2.0	-2.0	-2.0	-2.0	-2.0	-2.0	-2.0	-2.0	-2.0
Total Lost Time (s)	5.0	5.0	2.0	2.0	5.0	5.0	5.0	2.0	5.0	2.0	2.0	2.0
Lead/Lag												
Lead-Lag Optimize?												
Vehicle Extension (s)	3.0	3.0			3.0	3.0	3.0		3.0			
Recall Mode	C-Max	C-Max			C-Max	C-Max	None		None			
Act Effct Green (s)		69.0			69.0	69.0	11.0		11.0			
Actuated g/C Ratio		0.77			0.77	0.77	0.12		0.12			
v/c Ratio		0.97			0.20	0.11	1.06		0.51			
Control Delay		30.5			3.3	2.9	117.2		47.2			
Queue Delay		3.9			0.0	0.0	0.0		0.0			
Total Delay		34.4			3.3	2.9	117.2		47.2			
LOS		C			A	A	F		D			
Approach Delay		34.4			3.2							
Approach LOS		C			A							

Lanes, Volumes, Timings
 9: SR 1783 (Upward Rd) & I-26 NB On-Ramp

2011 Base Year - Build 6 Lanes

Timing Plan: PM Peak



Lane Group	EBL	EBT	EBR	WBL	WBT	WBR	NBL	NBT	NBR	SBL	SBT	SBR
Queue Length 50th (ft)		492			36	14	~143		54			
Queue Length 95th (ft)		#764			57	26	#285		105			
Internal Link Dist (ft)		550			242			366			578	
Turn Bay Length (ft)						50	150					
Base Capacity (vph)		936			1428	1146	216		193			
Starvation Cap Reductn		19			0	0	0		0			
Spillback Cap Reductn		0			0	0	0		0			
Storage Cap Reductn		0			0	0	0		0			
Reduced v/c Ratio		0.99			0.20	0.11	1.06		0.51			

Intersection Summary

Area Type: Other
 Cycle Length: 90
 Actuated Cycle Length: 90
 Offset: 13 (14%), Referenced to phase 2:EBTL and 6:WBT, Start of Green
 Natural Cycle: 90
 Control Type: Actuated-Coordinated
 Maximum v/c Ratio: 1.06
 Intersection Signal Delay: 38.8
 Intersection LOS: D
 Intersection Capacity Utilization 81.2%
 ICU Level of Service D
 Analysis Period (min) 15
 ~ Volume exceeds capacity, queue is theoretically infinite.
 Queue shown is maximum after two cycles.
 # 95th percentile volume exceeds capacity, queue may be longer.
 Queue shown is maximum after two cycles.

Splits and Phases: 9: SR 1783 (Upward Rd) & I-26 NB On-Ramp



Lanes, Volumes, Timings
 10: SR 1783 (Upward Rd) & I-26 SB Off-Ramp

2011 Base Year - Build 6 Lanes

Timing Plan: PM Peak



Lane Group	EBL	EBT	EBR	WBL	WBT	WBR	NBL	NBT	NBR	SBL	SBT	SBR
Lane Configurations		↑	↗		↖					↘		↗
Volume (vph)	0	707	210	69	397	0	0	0	0	114	0	358
Ideal Flow (vphpl)	1900	1900	1900	1900	1900	1900	1900	1900	1900	1900	1900	1900
Storage Length (ft)	0		200	0		0	0		0	0		100
Storage Lanes	0		1	0		0	0		0	1		1
Taper Length (ft)	100		100	100		100	100		100	100		100
Lane Util. Factor	1.00	1.00	1.00	1.00	1.00	1.00	1.00	1.00	1.00	1.00	1.00	1.00
Fr _t			0.850									0.850
Fl _t Protected					0.993					0.950		
Satd. Flow (prot)	0	1863	1495	0	1834	0	0	0	0	1770	0	1583
Fl _t Permitted					0.625					0.950		
Satd. Flow (perm)	0	1863	1495	0	1154	0	0	0	0	1770	0	1583
Right Turn on Red			No			No			No			No
Satd. Flow (RTOR)												
Link Speed (mph)		45			45			45			45	
Link Distance (ft)		549			630			547			651	
Travel Time (s)		8.3			9.5			8.3			9.9	
Peak Hour Factor	0.90	0.90	0.90	0.90	0.90	0.90	0.90	0.90	0.90	0.90	0.90	0.90
Heavy Vehicles (%)	5%	2%	8%	8%	2%	5%	5%	5%	5%	2%	5%	2%
Adj. Flow (vph)	0	786	233	77	441	0	0	0	0	127	0	398
Shared Lane Traffic (%)												
Lane Group Flow (vph)	0	786	233	0	518	0	0	0	0	127	0	398
Turn Type			Perm	Perm						Prot		custom
Protected Phases		2			6					4		
Permitted Phases			2	6								4
Detector Phase		2	2	6	6					4		4
Switch Phase												
Minimum Initial (s)		12.0	12.0	12.0	12.0					7.0		7.0
Minimum Split (s)		21.0	21.0	21.0	21.0					14.0		14.0
Total Split (s)	0.0	59.0	59.0	59.0	59.0	0.0	0.0	0.0	0.0	31.0	0.0	31.0
Total Split (%)	0.0%	65.6%	65.6%	65.6%	65.6%	0.0%	0.0%	0.0%	0.0%	34.4%	0.0%	34.4%
Maximum Green (s)		52.0	52.0	52.0	52.0					24.0		24.0
Yellow Time (s)		5.0	5.0	5.0	5.0					5.0		5.0
All-Red Time (s)		2.0	2.0	2.0	2.0					2.0		2.0
Lost Time Adjust (s)	-2.0	-2.0	-2.0	-2.0	-2.0	-2.0	-2.0	-2.0	-2.0	-2.0	-2.0	-2.0
Total Lost Time (s)	2.0	5.0	5.0	5.0	5.0	2.0	2.0	2.0	2.0	5.0	2.0	5.0
Lead/Lag												
Lead-Lag Optimize?												
Vehicle Extension (s)		3.0	3.0	3.0	3.0					3.0		3.0
Recall Mode		C-Max	C-Max	C-Max	C-Max					None		None
Act Effct Green (s)		54.7	54.7		54.7					25.3		25.3
Actuated g/C Ratio		0.61	0.61		0.61					0.28		0.28
v/c Ratio		0.69	0.26		0.74					0.26		0.89
Control Delay		16.3	9.3		17.8					26.4		55.4
Queue Delay		0.5	0.0		0.0					0.1		0.0
Total Delay		16.8	9.3		17.8					26.4		55.4
LOS		B	A		B					C		E
Approach Delay		15.1			17.8							
Approach LOS		B			B							

Lanes, Volumes, Timings
 10: SR 1783 (Upward Rd) & I-26 SB Off-Ramp

2011 Base Year - Build 6 Lanes

Timing Plan: PM Peak



Lane Group	EBL	EBT	EBR	WBL	WBT	WBR	NBL	NBT	NBR	SBL	SBT	SBR
Queue Length 50th (ft)		284	58		270					55		214
Queue Length 95th (ft)		423	96		m329					101		#378
Internal Link Dist (ft)		469			550			467			571	
Turn Bay Length (ft)			200									100
Base Capacity (vph)		1132	908		701					511		457
Starvation Cap Reductn		0	0		0					0		0
Spillback Cap Reductn		85	0		0					35		0
Storage Cap Reductn		0	0		0					0		0
Reduced v/c Ratio		0.75	0.26		0.74					0.27		0.87

Intersection Summary

Area Type: Other
 Cycle Length: 90
 Actuated Cycle Length: 90
 Offset: 4 (4%), Referenced to phase 2:EBT and 6:WBTL, Start of Green
 Natural Cycle: 70
 Control Type: Actuated-Coordinated
 Maximum v/c Ratio: 0.89
 Intersection Signal Delay: 24.2
 Intersection LOS: C
 Intersection Capacity Utilization 79.9%
 ICU Level of Service D
 Analysis Period (min) 15
 # 95th percentile volume exceeds capacity, queue may be longer.
 Queue shown is maximum after two cycles.
 m Volume for 95th percentile queue is metered by upstream signal.

Splits and Phases: 10: SR 1783 (Upward Rd) & I-26 SB Off-Ramp

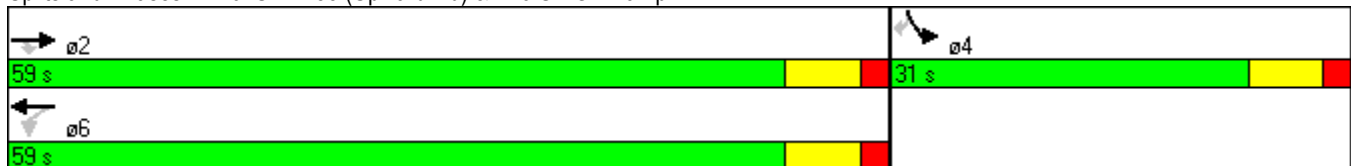

2011 Build 8 Lane

Lanes, Volumes, Timings
 1: NC 146 (Long Shoals Rd) & I-26 NB On-Ramp

2011 Base Year - Build 8 Lanes

Timing Plan: AM Peak

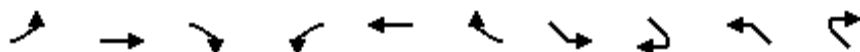

Lane Group	EBL	EBT	EBR2	WBL	WBT	WBR2	SEL	SER2	NWL	NWR2
Lane Configurations	↗↗	↑↑	↖	↗↗	↑↑	↖	↗↗	↖	↗↗	↖
Volume (vph)	185	456	188	470	609	783	744	234	190	356
Ideal Flow (vphpl)	1900	1900	1900	1900	1900	1900	1900	1900	1900	1900
Grade (%)		3%			-7%					
Storage Length (ft)	450			350			0		675	
Storage Lanes	1			2			2		1	
Taper Length (ft)	100			100			100		100	
Lane Util. Factor	0.97	0.95	1.00	0.97	0.95	1.00	0.97	1.00	0.97	1.00
Frt			0.850			0.850		0.850		0.850
Flt Protected	0.950			0.950			0.950		0.950	
Satd. Flow (prot)	3224	3452	1487	3387	3663	1562	3519	1607	3434	1599
Flt Permitted	0.950			0.950			0.950		0.950	
Satd. Flow (perm)	3224	3452	1487	3387	3663	1562	3519	1607	3434	1599
Right Turn on Red			No			No		No		No
Satd. Flow (RTOR)										
Link Speed (mph)		45			45					
Link Distance (ft)		1009			964					
Travel Time (s)		15.3			14.6					
Peak Hour Factor	0.90	0.90	0.90	0.90	0.90	0.90	0.90	0.90	0.90	0.90
Heavy Vehicles (%)	7%	3%	7%	7%	2%	7%	2%	3%	3%	2%
Adj. Flow (vph)	206	507	209	522	677	870	827	260	211	396
Shared Lane Traffic (%)										
Lane Group Flow (vph)	206	507	209	522	677	870	827	260	211	396
Turn Type	Prot		Free	Prot		Free	Prot	custom	Prot	Free
Protected Phases	5	2		1	6		4		8	
Permitted Phases			Free			Free		4		Free
Detector Phase	5	2		1	6		4	4	8	
Switch Phase										
Minimum Initial (s)	7.0	12.0		7.0	12.0		7.0	7.0	7.0	
Minimum Split (s)	16.0	20.0		15.0	21.0		16.0	16.0	15.0	
Total Split (s)	16.0	45.0	0.0	28.0	57.0	0.0	27.0	27.0	27.0	0.0
Total Split (%)	16.0%	45.0%	0.0%	28.0%	57.0%	0.0%	27.0%	27.0%	27.0%	0.0%
Maximum Green (s)	7.8	37.5		20.3	48.0		18.9	18.9	19.0	
Yellow Time (s)	3.4	4.3		4.0	5.2		3.8	3.8	3.7	
All-Red Time (s)	4.8	3.2		3.7	3.8		4.3	4.3	4.3	
Lost Time Adjust (s)	-3.2	-2.5	-2.5	-2.7	-4.0	-4.0	-3.1	-3.1	-3.0	0.0
Total Lost Time (s)	5.0	5.0	1.5	5.0	5.0	0.0	5.0	5.0	5.0	4.0
Lead/Lag	Lead	Lag		Lead	Lag					
Lead-Lag Optimize?	Yes	Yes		Yes	Yes					
Vehicle Extension (s)	2.0	6.0		2.0	6.0		2.0	2.0	2.0	
Minimum Gap (s)	3.0	3.0		3.0	3.0		3.0	3.0	3.0	
Time Before Reduce (s)	0.0	15.0		0.0	15.0		0.0	0.0	0.0	
Time To Reduce (s)	0.0	30.0		0.0	30.0		0.0	0.0	0.0	
Recall Mode	None	C-Max		None	C-Max		None	None	None	
Act Effct Green (s)	10.9	41.8	100.0	21.2	52.1	100.0	22.0	22.0	22.0	100.0
Actuated g/C Ratio	0.11	0.42	1.00	0.21	0.52	1.00	0.22	0.22	0.22	1.00
v/c Ratio	0.59	0.35	0.14	0.73	0.35	0.56	1.07	0.73	0.28	0.25
Control Delay	49.7	21.1	0.2	43.1	14.8	1.4	90.5	50.1	33.6	0.4
Queue Delay	0.0	0.0	0.0	0.0	0.0	0.0	0.0	0.0	0.0	0.0

Lanes, Volumes, Timings
 1: NC 146 (Long Shoals Rd) & I-26 NB On-Ramp

2011 Base Year - Build 8 Lanes

Timing Plan: AM Peak

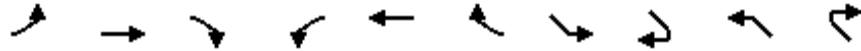

Lane Group	EBL	EBT	EBR2	WBL	WBT	WBR2	SEL	SER2	NWL	NWR2
Total Delay	49.7	21.1	0.2	43.1	14.8	1.4	90.5	50.1	33.6	0.4
LOS	D	C	A	D	B	A	F	D	C	A
Approach Delay	22.7			16.3						
Approach LOS	C			B						
Queue Length 50th (ft)	65	115	0	158	127	0	~302	155	58	0
Queue Length 95th (ft)	103	160	0	213	167	0	#421	#267	90	0
Internal Link Dist (ft)	929			884						
Turn Bay Length (ft)	450		300	350		300	425		675	575
Base Capacity (vph)	355	1444	1487	779	1908	1562	774	354	755	1599
Starvation Cap Reductn	0	0	0	0	0	0	0	0	0	0
Spillback Cap Reductn	0	0	0	0	0	0	0	0	0	0
Storage Cap Reductn	0	0	0	0	0	0	0	0	0	0
Reduced v/c Ratio	0.58	0.35	0.14	0.67	0.35	0.56	1.07	0.73	0.28	0.25

Intersection Summary

Area Type: Other
 Cycle Length: 100
 Actuated Cycle Length: 100
 Offset: 0 (0%), Referenced to phase 2:EBT and 6:WBT, Start of Green
 Natural Cycle: 60
 Control Type: Actuated-Coordinated
 Maximum v/c Ratio: 1.07
 Intersection Signal Delay: 32.0
 Intersection LOS: C
 Intersection Capacity Utilization 59.7%
 ICU Level of Service B
 Analysis Period (min) 15
 ~ Volume exceeds capacity, queue is theoretically infinite.
 Queue shown is maximum after two cycles.
 # 95th percentile volume exceeds capacity, queue may be longer.
 Queue shown is maximum after two cycles.

Splits and Phases: 1: NC 146 (Long Shoals Rd) & I-26 NB On-Ramp

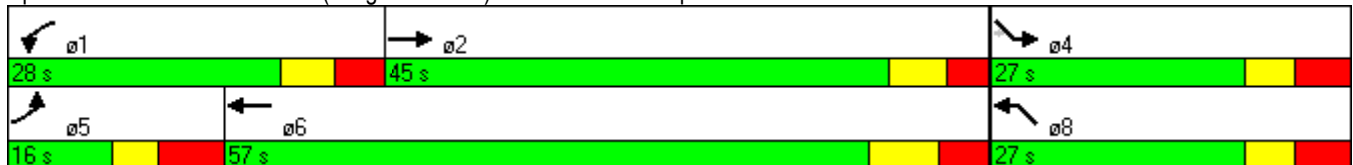

Lanes, Volumes, Timings
 2: I-26 NB On-Ramp & US 25 (Asheville Highway)

2011 Base Year - Build 8 Lanes

Timing Plan: AM Peak



Lane Group	EBL	EBT	EBR	WBL	WBT	WBR	NBL	NBT	NBR	SBL	SBT	SBR
Lane Configurations				↙		↗	↗	↗			↗	↗
Volume (vph)	0	0	0	103	0	337	495	899	0	0	1251	251
Ideal Flow (vphpl)	1900	1900	1900	1900	1900	1900	1900	1900	1900	1900	1900	1900
Grade (%)		0%			2%			-1%			2%	
Storage Length (ft)	0		0	0		150	0		0	0		300
Storage Lanes	0		0	1		2	1		0	0		1
Taper Length (ft)	100		100	100		100	100		100	100		100
Lane Util. Factor	1.00	1.00	1.00	1.00	1.00	0.88	1.00	0.95	1.00	1.00	0.95	1.00
Frt						0.850						0.850
Flt Protected				0.950			0.950					
Satd. Flow (prot)	0	0	0	1735	0	2706	1680	3489	0	0	3436	1480
Flt Permitted				0.950			0.950					
Satd. Flow (perm)	0	0	0	1735	0	2706	1680	3489	0	0	3436	1480
Right Turn on Red			No			Yes			No			No
Satd. Flow (RTOR)						374						
Link Speed (mph)		45			35			45			45	
Link Distance (ft)		533			612			601			596	
Travel Time (s)		8.1			11.9			9.1			9.0	
Peak Hour Factor	0.90	0.90	0.90	0.90	0.90	0.90	0.90	0.90	0.90	0.90	0.90	0.90
Heavy Vehicles (%)	5%	5%	5%	3%	5%	4%	8%	4%	5%	5%	4%	8%
Adj. Flow (vph)	0	0	0	114	0	374	550	999	0	0	1390	279
Shared Lane Traffic (%)												
Lane Group Flow (vph)	0	0	0	114	0	374	550	999	0	0	1390	279
Turn Type				Prot		custom	Prot					Free
Protected Phases				4			5	2			6	
Permitted Phases						4						Free
Detector Phase				4		4	5	2			6	
Switch Phase												
Minimum Initial (s)				7.0		7.0	7.0	12.0			12.0	
Minimum Split (s)				13.0		13.0	14.0	19.0			18.0	
Total Split (s)	0.0	0.0	0.0	14.0	0.0	14.0	43.0	96.0	0.0	0.0	53.0	0.0
Total Split (%)	0.0%	0.0%	0.0%	12.7%	0.0%	12.7%	39.1%	87.3%	0.0%	0.0%	48.2%	0.0%
Maximum Green (s)				8.0		8.0	36.6	89.9			47.7	
Yellow Time (s)				3.7		3.7	3.0	4.6			4.3	
All-Red Time (s)				2.3		2.3	3.4	1.5			1.0	
Lost Time Adjust (s)	-2.0	0.0	0.0	-1.0	0.0	-1.0	-1.4	-1.1	0.0	0.0	-0.3	0.0
Total Lost Time (s)	2.0	4.0	4.0	5.0	4.0	5.0	5.0	5.0	4.0	4.0	5.0	4.0
Lead/Lag							Lag				Lead	
Lead-Lag Optimize?							Yes				Yes	
Vehicle Extension (s)				2.0		2.0	2.0	8.0			8.0	
Minimum Gap (s)				3.0		3.0	3.0	5.5			5.5	
Time Before Reduce (s)				0.0		0.0	0.0	15.0			15.0	
Time To Reduce (s)				0.0		0.0	0.0	50.0			50.0	
Recall Mode				None		None	None	C-Max			C-Max	
Act Effct Green (s)				9.0		9.0	38.0	91.0			48.0	110.0
Actuated g/C Ratio				0.08		0.08	0.35	0.83			0.44	1.00
v/c Ratio				0.81		0.66	0.95	0.35			0.93	0.19
Control Delay				87.9		11.3	19.2	1.4			41.2	0.3
Queue Delay				0.0		0.0	0.0	0.0			0.0	0.0

Lanes, Volumes, Timings
 2: I-26 NB On-Ramp & US 25 (Asheville Highway)

2011 Base Year - Build 8 Lanes

Timing Plan: AM Peak



Lane Group	EBL	EBT	EBR	WBL	WBT	WBR	NBL	NBT	NBR	SBL	SBT	SBR
Total Delay				87.9		11.3	19.2	1.4			41.2	0.3
LOS				F		B	B	A			D	A
Approach Delay								7.7			34.3	
Approach LOS								A			C	
Queue Length 50th (ft)				81		0	74	52			478	0
Queue Length 95th (ft)				#180		49	m67	m27			#633	0
Internal Link Dist (ft)		453			532			521			516	
Turn Bay Length (ft)						150						300
Base Capacity (vph)				142		565	580	2887			1500	1480
Starvation Cap Reductn				0		0	0	0			0	0
Spillback Cap Reductn				0		0	0	0			0	0
Storage Cap Reductn				0		0	0	0			0	0
Reduced v/c Ratio				0.80		0.66	0.95	0.35			0.93	0.19

Intersection Summary

Area Type: Other
 Cycle Length: 110
 Actuated Cycle Length: 110
 Offset: 14 (13%), Referenced to phase 2:NBT and 6:SBT, Start of Green
 Natural Cycle: 90
 Control Type: Actuated-Coordinated
 Maximum v/c Ratio: 0.95
 Intersection Signal Delay: 22.5
 Intersection LOS: C
 Intersection Capacity Utilization 81.5%
 ICU Level of Service D
 Analysis Period (min) 15
 # 95th percentile volume exceeds capacity, queue may be longer.
 Queue shown is maximum after two cycles.
 m Volume for 95th percentile queue is metered by upstream signal.

Splits and Phases: 2: I-26 NB On-Ramp & US 25 (Asheville Highway)

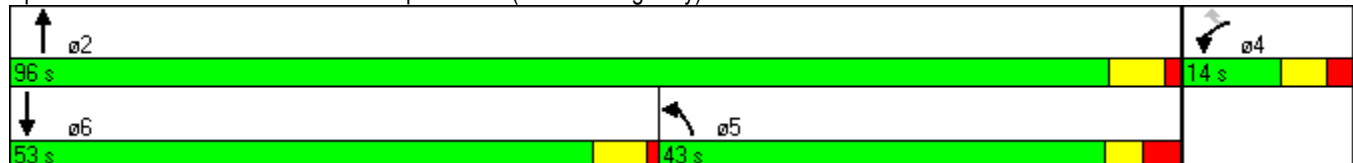

Lanes, Volumes, Timings
 3: I-26 SB Off-Ramp & US 25 (Asheville Highway)

2011 Base Year - Build 8 Lanes

Timing Plan: AM Peak



Lane Group	EBL	EBT	EBR	WBL	WBT	WBR	NBL	NBT	NBR	SBL	SBT	SBR
Lane Configurations	↘		↗					↑↑	↗	↘	↑↑	
Volume (vph)	246	0	612	0	0	0	0	1148	103	426	928	0
Ideal Flow (vphpl)	1900	1900	1900	1900	1900	1900	1900	1900	1900	1900	1900	1900
Grade (%)		3%			0%			4%			1%	
Storage Length (ft)	0		100	0		0	0		500	0		0
Storage Lanes	1		1	0		0	0		1	1		0
Taper Length (ft)	100		100	100		100	100		100	100		100
Lane Util. Factor	1.00	1.00	1.00	1.00	1.00	1.00	1.00	0.95	1.00	1.00	0.95	1.00
Frt			0.850						0.850			
Flt Protected	0.950									0.950		
Satd. Flow (prot)	1710	0	1544	0	0	0	0	3435	1465	1663	3487	0
Flt Permitted	0.950									0.950		
Satd. Flow (perm)	1710	0	1544	0	0	0	0	3435	1465	1663	3487	0
Right Turn on Red			No			No			No			No
Satd. Flow (RTOR)												
Link Speed (mph)		35			45			45			45	
Link Distance (ft)		471			598			795			601	
Travel Time (s)		9.2			9.1			12.0			9.1	
Peak Hour Factor	0.90	0.90	0.90	0.90	0.90	0.90	0.90	0.90	0.90	0.90	0.90	0.90
Heavy Vehicles (%)	4%	5%	3%	5%	5%	5%	5%	3%	8%	8%	3%	5%
Adj. Flow (vph)	273	0	680	0	0	0	0	1276	114	473	1031	0
Shared Lane Traffic (%)												
Lane Group Flow (vph)	273	0	680	0	0	0	0	1276	114	473	1031	0
Turn Type	Prot		custom							Free	Prot	
Protected Phases	4		4					2		1	6	
Permitted Phases									Free			
Detector Phase	4		4					2		1	6	
Switch Phase												
Minimum Initial (s)	7.0		7.0					12.0		7.0	12.0	
Minimum Split (s)	13.0		13.0					18.0		14.0	18.0	
Total Split (s)	42.0	0.0	42.0	0.0	0.0	0.0	0.0	39.0	0.0	29.0	68.0	0.0
Total Split (%)	38.2%	0.0%	38.2%	0.0%	0.0%	0.0%	0.0%	35.5%	0.0%	26.4%	61.8%	0.0%
Maximum Green (s)	36.0		36.0					33.3		22.5	62.3	
Yellow Time (s)	4.0		4.0					4.7		4.0	4.7	
All-Red Time (s)	2.0		2.0					1.0		2.5	1.0	
Lost Time Adjust (s)	-1.0	-2.0	-1.0	-2.0	-2.0	-2.0	-2.0	-0.7	-0.7	-1.5	-0.7	-2.0
Total Lost Time (s)	5.0	2.0	5.0	2.0	2.0	2.0	2.0	5.0	3.3	5.0	5.0	2.0
Lead/Lag								Lag		Lead		
Lead-Lag Optimize?								Yes		Yes		
Vehicle Extension (s)	2.0		2.0					8.0		2.0	8.0	
Minimum Gap (s)	3.0		3.0					5.5		3.0	5.5	
Time Before Reduce (s)	0.0		0.0					15.0		0.0	15.0	
Time To Reduce (s)	0.0		0.0					50.0		0.0	50.0	
Recall Mode	None		None					C-Max		None	C-Max	
Act Effct Green (s)	37.0		37.0					34.0	110.0	24.0	63.0	
Actuated g/C Ratio	0.34		0.34					0.31	1.00	0.22	0.57	
v/c Ratio	0.47		1.31					1.20	0.08	1.30	0.52	
Control Delay	32.2		185.1					134.6	0.1	170.8	6.6	
Queue Delay	0.0		0.0					0.0	0.0	0.0	1.2	

Lanes, Volumes, Timings
 3: I-26 SB Off-Ramp & US 25 (Asheville Highway)

2011 Base Year - Build 8 Lanes

Timing Plan: AM Peak



Lane Group	EBL	EBT	EBR	WBL	WBT	WBR	NBL	NBT	NBR	SBL	SBT	SBR
Total Delay	32.2		185.1					134.6	0.1	170.8	7.8	
LOS	C		F					F	A	F	A	
Approach Delay								123.6			59.0	
Approach LOS								F			E	
Queue Length 50th (ft)	151		~619					~577	0	~416	175	
Queue Length 95th (ft)	231		#845					#713	0	m#483	m186	
Internal Link Dist (ft)		391			518			715			521	
Turn Bay Length (ft)			100						500			
Base Capacity (vph)	575		519					1062	1465	363	1997	
Starvation Cap Reductn	0		0					0	0	0	688	
Spillback Cap Reductn	0		0					0	0	0	0	
Storage Cap Reductn	0		0					0	0	0	0	
Reduced v/c Ratio	0.47		1.31					1.20	0.08	1.30	0.79	

Intersection Summary

Area Type: Other
 Cycle Length: 110
 Actuated Cycle Length: 110
 Offset: 61 (55%), Referenced to phase 2:NBT and 6:SBT, Start of Green
 Natural Cycle: 130
 Control Type: Actuated-Coordinated
 Maximum v/c Ratio: 1.31
 Intersection Signal Delay: 102.7
 Intersection LOS: F
 Intersection Capacity Utilization 81.5%
 ICU Level of Service D
 Analysis Period (min) 15
 ~ Volume exceeds capacity, queue is theoretically infinite.
 Queue shown is maximum after two cycles.
 # 95th percentile volume exceeds capacity, queue may be longer.
 Queue shown is maximum after two cycles.
 m Volume for 95th percentile queue is metered by upstream signal.

Splits and Phases: 3: I-26 SB Off-Ramp & US 25 (Asheville Highway)

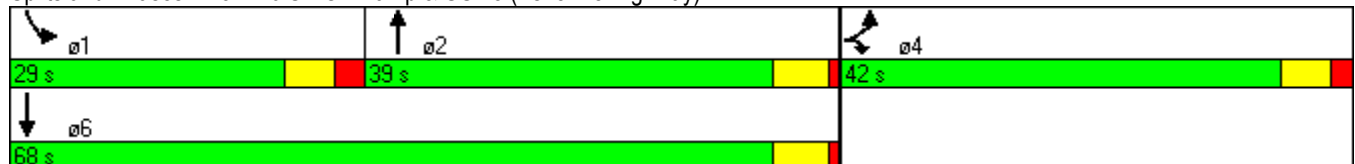

Lanes, Volumes, Timings
6: US 64 & SR 1516 (Francis Rd)

2011 Base Year - Build 8 Lanes
Timing Plan: AM Peak



Lane Group	EBL	EBT	EBR	WBL	WBT	WBR	NBL	NBT	NBR	SBL	SBT	SBR
Lane Configurations												
Volume (vph)	117	1513	387	76	1919	26	342	5	53	26	5	117
Ideal Flow (vphpl)	1900	1900	1900	1900	1900	1900	1900	1900	1900	1900	1900	1900
Grade (%)		-1%			4%			-1%			2%	
Storage Length (ft)	150		0	125		0	150		150	0		150
Storage Lanes	1		1	1		0	1		1	0		1
Taper Length (ft)	100		100	100		100	100		100	100		100
Lane Util. Factor	1.00	0.95	1.00	1.00	0.95	0.95	0.95	0.95	1.00	1.00	1.00	1.00
Frt			0.850		0.998				0.850			0.850
Flt Protected	0.950			0.950			0.950	0.954			0.960	
Satd. Flow (prot)	1778	3557	1591	1734	3461	0	1690	1697	1591	0	1770	1567
Flt Permitted	0.950			0.950			0.950	0.954			0.960	
Satd. Flow (perm)	1778	3557	1591	1734	3461	0	1690	1697	1591	0	1770	1567
Right Turn on Red			No			No			No			No
Satd. Flow (RTOR)												
Link Speed (mph)		45			45			35			35	
Link Distance (ft)		835			622			375			406	
Travel Time (s)		12.7			9.4			7.3			7.9	
Peak Hour Factor	0.90	0.90	0.90	0.90	0.90	0.90	0.90	0.90	0.90	0.90	0.90	0.90
Heavy Vehicles (%)	2%	2%	2%	2%	2%	2%	2%	2%	2%	2%	2%	2%
Adj. Flow (vph)	130	1681	430	84	2132	29	380	6	59	29	6	130
Shared Lane Traffic (%)							49%					
Lane Group Flow (vph)	130	1681	430	84	2161	0	194	192	59	0	35	130
Turn Type	Prot		Perm	Prot			Split		pm+ov	Split		pm+ov
Protected Phases	5	2		1	6		4	4	1	3	3	5
Permitted Phases			2						4			3
Detector Phase	5	2	2	1	6		4	4	1	3	3	5
Switch Phase												
Minimum Initial (s)	7.0	12.0	12.0	7.0	12.0		7.0	7.0	7.0	7.0	7.0	7.0
Minimum Split (s)	13.0	18.0	18.0	13.0	18.0		14.0	14.0	13.0	14.0	14.0	13.0
Total Split (s)	14.0	83.0	83.0	14.0	83.0	0.0	19.0	19.0	14.0	14.0	14.0	14.0
Total Split (%)	10.8%	63.8%	63.8%	10.8%	63.8%	0.0%	14.6%	14.6%	10.8%	10.8%	10.8%	10.8%
Maximum Green (s)	8.4	77.0	77.0	8.6	77.4		12.4	12.4	8.6	7.5	7.5	8.4
Yellow Time (s)	3.2	4.6	4.6	3.0	4.2		3.9	3.9	3.0	3.7	3.7	3.2
All-Red Time (s)	2.4	1.4	1.4	2.4	1.4		2.7	2.7	2.4	2.8	2.8	2.4
Lost Time Adjust (s)	-0.6	-1.0	-1.0	-0.4	-0.6	-2.0	-1.6	-1.6	-0.4	-2.0	-1.5	-0.6
Total Lost Time (s)	5.0	5.0	5.0	5.0	5.0	2.0	5.0	5.0	5.0	4.5	5.0	5.0
Lead/Lag	Lag	Lag	Lag	Lead	Lead		Lag	Lag	Lead	Lead	Lead	Lag
Lead-Lag Optimize?	Yes	Yes	Yes	Yes	Yes		Yes	Yes	Yes	Yes	Yes	Yes
Vehicle Extension (s)	1.0	2.0	2.0	1.0	2.0		1.0	1.0	1.0	1.0	1.0	1.0
Recall Mode	None	C-Max	C-Max	None	C-Max		None	None	None	None	None	None
Act Effct Green (s)	9.0	80.2	80.2	8.6	79.8		17.9	17.9	31.6		8.6	17.2
Actuated g/C Ratio	0.07	0.62	0.62	0.07	0.61		0.14	0.14	0.24		0.07	0.13
v/c Ratio	1.06	0.77	0.44	0.73	1.02		0.83	0.82	0.15		0.30	0.62
Control Delay	151.3	18.8	11.2	93.0	49.3		83.3	81.8	41.8		64.6	65.4
Queue Delay	0.0	0.0	0.0	0.0	0.0		0.0	0.0	0.0		0.0	0.0
Total Delay	151.3	18.8	11.2	93.0	49.3		83.3	81.8	41.8		64.6	65.4
LOS	F	B	B	F	D		F	F	D		E	E
Approach Delay		25.0			51.0			77.1			65.2	

Lanes, Volumes, Timings
6: US 64 & SR 1516 (Francis Rd)

2011 Base Year - Build 8 Lanes

Timing Plan: AM Peak



Lane Group	EBL	EBT	EBR	WBL	WBT	WBR	NBL	NBT	NBR	SBL	SBT	SBR
Approach LOS	C			D			E			E		
Queue Length 50th (ft)	~121	616	171	71	~1034		~184	~175	41		29	100
Queue Length 95th (ft)	#256	727	241	#152	#1168		#355	#349	81		64	166
Internal Link Dist (ft)		755			542			295			326	
Turn Bay Length (ft)	150			125			150		150			150
Base Capacity (vph)	123	2194	982	120	2125		233	234	391		123	208
Starvation Cap Reductn	0	0	0	0	0		0	0	0		0	0
Spillback Cap Reductn	0	0	0	0	0		0	0	0		0	0
Storage Cap Reductn	0	0	0	0	0		0	0	0		0	0
Reduced v/c Ratio	1.06	0.77	0.44	0.70	1.02		0.83	0.82	0.15		0.28	0.63

Intersection Summary

Area Type: Other
 Cycle Length: 130
 Actuated Cycle Length: 130
 Offset: 99 (76%), Referenced to phase 2:EBT and 6:WBT, Start of Green
 Natural Cycle: 140
 Control Type: Actuated-Coordinated
 Maximum v/c Ratio: 1.06
 Intersection Signal Delay: 42.3
 Intersection Capacity Utilization 89.1%
 Analysis Period (min) 15
 Intersection LOS: D
 ICU Level of Service E

~ Volume exceeds capacity, queue is theoretically infinite.
 Queue shown is maximum after two cycles.

95th percentile volume exceeds capacity, queue may be longer.
 Queue shown is maximum after two cycles.

Splits and Phases: 6: US 64 & SR 1516 (Francis Rd)



Lanes, Volumes, Timings
7: US 64 & I-26 SB Off-Ramp

2011 Base Year - Build 8 Lanes

Timing Plan: AM Peak

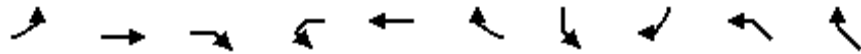

Lane Group	EBL	EBT	EBR	WBL	WBT	WBR	SBL	SBR	NWL	NWR
Lane Configurations		↑↑	↑		↑↑			↑↑		
Volume (vph)	0	1489	221	0	1676	0	0	447	0	0
Ideal Flow (vphpl)	1900	1900	1900	1900	1900	1900	1900	1900	1900	1900
Grade (%)		3%			-3%		-3%		0%	
Storage Length (ft)	0		400	0		0	0	500	0	0
Storage Lanes	0		1	0		0	0	1	0	0
Taper Length (ft)	100		100	100		100	100	100	100	100
Lane Util. Factor	1.00	0.95	1.00	1.00	0.95	1.00	1.00	0.88	1.00	1.00
Frt			0.850					0.850		
Flt Protected										
Satd. Flow (prot)	0	3486	1473	0	3592	0	0	2828	0	0
Flt Permitted										
Satd. Flow (perm)	0	3486	1473	0	3592	0	0	2828	0	0
Right Turn on Red			No			No		No		
Satd. Flow (RTOR)										
Link Speed (mph)		45			45		35		45	
Link Distance (ft)		728			791		804		308	
Travel Time (s)		11.0			12.0		15.7		4.7	
Peak Hour Factor	0.90	0.90	0.90	0.90	0.90	0.90	0.90	0.90	0.90	0.90
Heavy Vehicles (%)	5%	2%	8%	5%	2%	5%	5%	2%	5%	5%
Adj. Flow (vph)	0	1654	246	0	1862	0	0	497	0	0
Shared Lane Traffic (%)										
Lane Group Flow (vph)	0	1654	246	0	1862	0	0	497	0	0
Turn Type			Perm					custom		
Protected Phases		Free			6			4		
Permitted Phases			Free							
Detector Phase					6			4		
Switch Phase										
Minimum Initial (s)					12.0			7.0		
Minimum Split (s)					18.0			13.0		
Total Split (s)	0.0	0.0	0.0	0.0	92.0	0.0	0.0	38.0	0.0	0.0
Total Split (%)	0.0%	0.0%	0.0%	0.0%	70.8%	0.0%	0.0%	29.2%	0.0%	0.0%
Maximum Green (s)					86.2			32.9		
Yellow Time (s)					4.8			4.1		
All-Red Time (s)					1.0			1.0		
Lost Time Adjust (s)	-2.0	0.0	-2.0	-2.0	-0.8	-2.0	-2.0	-0.1	-2.0	-2.0
Total Lost Time (s)	2.0	4.0	2.0	2.0	5.0	2.0	2.0	5.0	2.0	2.0
Lead/Lag										
Lead-Lag Optimize?										
Vehicle Extension (s)					2.0			1.0		
Recall Mode					C-Max			None		
Act Effct Green (s)		130.0	130.0		93.6			26.4		
Actuated g/C Ratio		1.00	1.00		0.72			0.20		
v/c Ratio		0.47	0.17		0.72			0.86		
Control Delay		0.2	0.1		7.7			65.5		
Queue Delay		0.0	0.0		0.2			0.0		
Total Delay		0.2	0.1		8.0			65.5		
LOS		A	A		A			E		
Approach Delay		0.2			8.0					

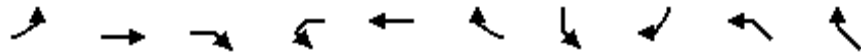

Lane Group	EBL	EBT	EBR	WBL	WBT	WBR	SBL	SBR	NWL	NWR
Approach LOS		A			A					
Queue Length 50th (ft)		0	0		233			231		
Queue Length 95th (ft)		0	m0		m459			285		
Internal Link Dist (ft)		648			711		724		228	
Turn Bay Length (ft)			400					500		
Base Capacity (vph)		3486	1473		2586			718		
Starvation Cap Reductn		0	0		0			0		
Spillback Cap Reductn		0	0		190			0		
Storage Cap Reductn		0	0		0			0		
Reduced v/c Ratio		0.47	0.17		0.78			0.69		

Intersection Summary

Area Type: Other
 Cycle Length: 130
 Actuated Cycle Length: 130
 Offset: 0 (0%), Referenced to phase 6:WBT, Start of Green, Master Intersection
 Natural Cycle: 60
 Control Type: Actuated-Coordinated
 Maximum v/c Ratio: 0.86
 Intersection Signal Delay: 11.2
 Intersection LOS: B
 Intersection Capacity Utilization 82.7%
 ICU Level of Service E
 Analysis Period (min) 15
 m Volume for 95th percentile queue is metered by upstream signal.

Splits and Phases: 7: US 64 & I-26 SB Off-Ramp



Lanes, Volumes, Timings
8: US 64 & SR 1634 (Carolina Village Rd)

2011 Base Year - Build 8 Lanes
Timing Plan: AM Peak



Lane Group	EBL	EBT	EBR	WBL	WBT	WBR	NBL	NBT	NBR	SBL	SBT	SBR
Lane Configurations												
Volume (vph)	53	1494	64	145	1846	110	61	15	112	122	22	73
Ideal Flow (vphpl)	1900	1900	1900	1900	1900	1900	1900	1900	1900	1900	1900	1900
Grade (%)		1%			-3%			3%				-1%
Storage Length (ft)	100		0	100		0	0		0	0		150
Storage Lanes	1		0	1		1	0		0	0		1
Taper Length (ft)	100		100	100		100	100		100	100		100
Lane Util. Factor	1.00	0.95	0.95	1.00	0.95	1.00	1.00	1.00	1.00	1.00	1.00	1.00
Frt		0.994				0.850		0.920				0.850
Flt Protected	0.950			0.950				0.984			0.959	
Satd. Flow (prot)	1761	3500	0	1796	3592	1607	0	1661	0	0	1795	1591
Flt Permitted	0.950			0.950				0.667			0.496	
Satd. Flow (perm)	1761	3500	0	1796	3592	1607	0	1126	0	0	929	1591
Right Turn on Red			No			No			No			No
Satd. Flow (RTOR)												
Link Speed (mph)		45			45			30			30	
Link Distance (ft)		560			728			219			359	
Travel Time (s)		8.5			11.0			5.0			8.2	
Peak Hour Factor	0.90	0.90	0.90	0.90	0.90	0.90	0.90	0.90	0.90	0.90	0.90	0.90
Heavy Vehicles (%)	2%	2%	2%	2%	2%	2%	2%	2%	2%	2%	2%	2%
Adj. Flow (vph)	59	1660	71	161	2051	122	68	17	124	136	24	81
Shared Lane Traffic (%)												
Lane Group Flow (vph)	59	1731	0	161	2051	122	0	209	0	0	160	81
Turn Type	Prot			Prot		Perm	Perm			Perm		pm+ov
Protected Phases	5	2		1	6			8			4	5
Permitted Phases						6	8			4		4
Detector Phase	5	2		1	6	6	8	8		4	4	5
Switch Phase												
Minimum Initial (s)	7.0	12.0		7.0	12.0	12.0	7.0	7.0		7.0	7.0	7.0
Minimum Split (s)	13.0	18.0		13.0	19.0	19.0	13.0	13.0		13.0	13.0	13.0
Total Split (s)	13.0	78.0	0.0	20.0	85.0	85.0	32.0	32.0	0.0	32.0	32.0	13.0
Total Split (%)	10.0%	60.0%	0.0%	15.4%	65.4%	65.4%	24.6%	24.6%	0.0%	24.6%	24.6%	10.0%
Maximum Green (s)	7.1	72.4		14.6	78.8	78.8	26.2	26.2		26.1	26.1	7.1
Yellow Time (s)	3.0	4.4		3.0	4.8	4.8	3.4	3.4		3.6	3.6	3.0
All-Red Time (s)	2.9	1.2		2.4	1.4	1.4	2.4	2.4		2.3	2.3	2.9
Lost Time Adjust (s)	-0.9	-0.6	-2.0	-0.4	-1.2	-1.2	-2.0	-0.8	-2.0	-2.0	-0.9	-0.9
Total Lost Time (s)	5.0	5.0	2.0	5.0	5.0	5.0	3.8	5.0	2.0	3.9	5.0	5.0
Lead/Lag	Lag	Lag		Lead	Lead	Lead						Lag
Lead-Lag Optimize?	Yes	Yes		Yes	Yes	Yes						Yes
Vehicle Extension (s)	1.0	2.0		1.0	2.0	2.0	1.0	1.0		1.0	1.0	1.0
Recall Mode	None	C-Max		None	C-Max	C-Max	None	None		None	None	None
Act Effct Green (s)	8.0	76.3		13.7	82.1	82.1		24.9			24.9	37.9
Actuated g/C Ratio	0.06	0.59		0.11	0.63	0.63		0.19			0.19	0.29
v/c Ratio	0.55	0.84		0.85	0.90	0.12		0.97			0.90	0.17
Control Delay	78.3	27.7		88.1	20.3	6.0		105.0			96.0	34.6
Queue Delay	0.0	0.0		0.0	1.9	0.0		0.0			0.0	0.0
Total Delay	78.3	27.7		88.1	22.2	6.0		105.0			96.0	34.6
LOS	E	C		F	C	A		F			F	C
Approach Delay		29.4			25.9			105.0			75.3	

Lanes, Volumes, Timings
 8: US 64 & SR 1634 (Carolina Village Rd)

2011 Base Year - Build 8 Lanes

Timing Plan: AM Peak



Lane Group	EBL	EBT	EBR	WBL	WBT	WBR	NBL	NBT	NBR	SBL	SBT	SBR
Approach LOS		C			C			F			E	
Queue Length 50th (ft)	49	638		127	762	27		173			130	50
Queue Length 95th (ft)	#103	760		m#211	695	m36		#322			#255	92
Internal Link Dist (ft)		480			648			139			279	
Turn Bay Length (ft)	100			100								150
Base Capacity (vph)	108	2055		207	2267	1015		234			193	465
Starvation Cap Reductn	0	0		0	109	0		0			0	0
Spillback Cap Reductn	0	0		0	0	0		0			0	0
Storage Cap Reductn	0	0		0	0	0		0			0	0
Reduced v/c Ratio	0.55	0.84		0.78	0.95	0.12		0.89			0.83	0.17

Intersection Summary

Area Type: Other
 Cycle Length: 130
 Actuated Cycle Length: 130
 Offset: 26 (20%), Referenced to phase 2:EBT and 6:WBT, Start of Green
 Natural Cycle: 90
 Control Type: Actuated-Coordinated
 Maximum v/c Ratio: 0.97
 Intersection Signal Delay: 33.5
 Intersection LOS: C
 Intersection Capacity Utilization 87.3%
 ICU Level of Service E
 Analysis Period (min) 15
 # 95th percentile volume exceeds capacity, queue may be longer.
 Queue shown is maximum after two cycles.
 m Volume for 95th percentile queue is metered by upstream signal.

Splits and Phases: 8: US 64 & SR 1634 (Carolina Village Rd)

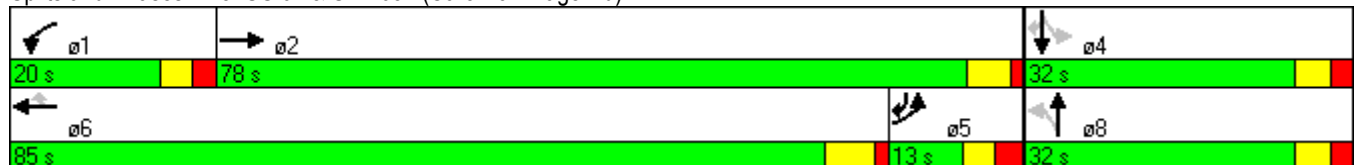

Lanes, Volumes, Timings
9: SR 1783 (Upward Rd) & I-26 NB On-Ramp

2011 Base Year - Build 8 Lanes
Timing Plan: AM Peak



Lane Group	EBL	EBT	EBR	WBL	WBT	WBR	NBL	NBT	NBR	SBL	SBT	SBR
Lane Configurations		↕			↑	↗	↖		↗			
Volume (vph)	367	307	0	0	337	119	204	0	65	0	0	0
Ideal Flow (vphpl)	1900	1900	1900	1900	1900	1900	1900	1900	1900	1900	1900	1900
Storage Length (ft)	0		0	0		50	150		0	0		0
Storage Lanes	0		0	0		1	1		1	0		0
Taper Length (ft)	100		100	100		100	100		100	100		100
Lane Util. Factor	1.00	1.00	1.00	1.00	1.00	1.00	1.00	1.00	1.00	1.00	1.00	1.00
Fr _t						0.850			0.850			
Fl _t Protected		0.973					0.950					
Satd. Flow (prot)	0	1756	0	0	1863	1495	1770	0	1583	0	0	0
Fl _t Permitted		0.629					0.950					
Satd. Flow (perm)	0	1135	0	0	1863	1495	1770	0	1583	0	0	0
Right Turn on Red			No			No			No			No
Satd. Flow (RTOR)												
Link Speed (mph)		45			45			45				45
Link Distance (ft)		630			322			446				658
Travel Time (s)		9.5			4.9			6.8				10.0
Peak Hour Factor	0.90	0.90	0.90	0.90	0.90	0.90	0.90	0.90	0.90	0.90	0.90	0.90
Heavy Vehicles (%)	8%	2%	5%	5%	2%	8%	2%	5%	2%	5%	5%	5%
Adj. Flow (vph)	408	341	0	0	374	132	227	0	72	0	0	0
Shared Lane Traffic (%)												
Lane Group Flow (vph)	0	749	0	0	374	132	227	0	72	0	0	0
Turn Type	Perm					Perm	Prot		custom			
Protected Phases		2			6		8					
Permitted Phases	2					6			8			
Detector Phase	2	2			6	6	8		8			
Switch Phase												
Minimum Initial (s)	12.0	12.0			12.0	12.0	7.0		7.0			
Minimum Split (s)	21.0	21.0			21.0	21.0	14.0		14.0			
Total Split (s)	71.0	71.0	0.0	0.0	71.0	71.0	19.0	0.0	19.0	0.0	0.0	0.0
Total Split (%)	78.9%	78.9%	0.0%	0.0%	78.9%	78.9%	21.1%	0.0%	21.1%	0.0%	0.0%	0.0%
Maximum Green (s)	64.0	64.0			64.0	64.0	12.0		12.0			
Yellow Time (s)	5.0	5.0			5.0	5.0	5.0		5.0			
All-Red Time (s)	2.0	2.0			2.0	2.0	2.0		2.0			
Lost Time Adjust (s)	-2.0	-2.0	-2.0	-2.0	-2.0	-2.0	-2.0	-2.0	-2.0	-2.0	-2.0	-2.0
Total Lost Time (s)	5.0	5.0	2.0	2.0	5.0	5.0	5.0	2.0	5.0	2.0	2.0	2.0
Lead/Lag												
Lead-Lag Optimize?												
Vehicle Extension (s)	3.0	3.0			3.0	3.0	3.0		3.0			
Recall Mode	C-Max	C-Max			C-Max	C-Max	None		None			
Act Effct Green (s)		66.0			66.0	66.0	14.0		14.0			
Actuated g/C Ratio		0.73			0.73	0.73	0.16		0.16			
v/c Ratio		0.90			0.27	0.12	0.83		0.29			
Control Delay		21.9			4.6	3.8	62.4		37.3			
Queue Delay		0.0			0.0	0.0	0.0		0.0			
Total Delay		21.9			4.6	3.8	62.4		37.3			
LOS		C			A	A	E		D			
Approach Delay		21.9			4.4							
Approach LOS		C			A							

Lanes, Volumes, Timings
 9: SR 1783 (Upward Rd) & I-26 NB On-Ramp

2011 Base Year - Build 8 Lanes
 Timing Plan: AM Peak



Lane Group	EBL	EBT	EBR	WBL	WBT	WBR	NBL	NBT	NBR	SBL	SBT	SBR
Queue Length 50th (ft)		339			59	18	127		37			
Queue Length 95th (ft)		#608			90	34	#249		77			
Internal Link Dist (ft)		550			242			366			578	
Turn Bay Length (ft)						50	150					
Base Capacity (vph)		832			1366	1096	275		246			
Starvation Cap Reductn		0			0	0	0		0			
Spillback Cap Reductn		0			0	0	0		0			
Storage Cap Reductn		0			0	0	0		0			
Reduced v/c Ratio		0.90			0.27	0.12	0.83		0.29			

Intersection Summary

Area Type: Other
 Cycle Length: 90
 Actuated Cycle Length: 90
 Offset: 9 (10%), Referenced to phase 2:EBTL and 6:WBT, Start of Green
 Natural Cycle: 80
 Control Type: Actuated-Coordinated
 Maximum v/c Ratio: 0.90
 Intersection Signal Delay: 22.8
 Intersection LOS: C
 Intersection Capacity Utilization 77.2%
 ICU Level of Service D
 Analysis Period (min) 15
 # 95th percentile volume exceeds capacity, queue may be longer.
 Queue shown is maximum after two cycles.

Splits and Phases: 9: SR 1783 (Upward Rd) & I-26 NB On-Ramp



Lanes, Volumes, Timings
 10: SR 1783 (Upward Rd) & I-26 SB Off-Ramp

2011 Base Year - Build 8 Lanes

Timing Plan: AM Peak



Lane Group	EBL	EBT	EBR	WBL	WBT	WBR	NBL	NBT	NBR	SBL	SBT	SBR
Lane Configurations		↑	↗		↖					↘		↗
Volume (vph)	0	559	200	84	457	0	0	0	0	115	0	465
Ideal Flow (vphpl)	1900	1900	1900	1900	1900	1900	1900	1900	1900	1900	1900	1900
Storage Length (ft)	0		200	0		0	0		0	0		100
Storage Lanes	0		1	0		0	0		0	1		1
Taper Length (ft)	100		100	100		100	100		100	100		100
Lane Util. Factor	1.00	1.00	1.00	1.00	1.00	1.00	1.00	1.00	1.00	1.00	1.00	1.00
Fr _t			0.850									0.850
Fl _t Protected					0.992					0.950		
Satd. Flow (prot)	0	1863	1495	0	1831	0	0	0	0	1770	0	1583
Fl _t Permitted					0.697					0.950		
Satd. Flow (perm)	0	1863	1495	0	1287	0	0	0	0	1770	0	1583
Right Turn on Red			No			No			No			No
Satd. Flow (RTOR)												
Link Speed (mph)		45			45			45			45	
Link Distance (ft)		549			630			547			651	
Travel Time (s)		8.3			9.5			8.3			9.9	
Peak Hour Factor	0.90	0.90	0.90	0.90	0.90	0.90	0.90	0.90	0.90	0.90	0.90	0.90
Heavy Vehicles (%)	5%	2%	8%	8%	2%	5%	5%	5%	5%	2%	5%	2%
Adj. Flow (vph)	0	621	222	93	508	0	0	0	0	128	0	517
Shared Lane Traffic (%)												
Lane Group Flow (vph)	0	621	222	0	601	0	0	0	0	128	0	517
Turn Type			Perm	Perm						Prot		custom
Protected Phases		2			6					4		
Permitted Phases			2	6								4
Detector Phase		2	2	6	6					4		4
Switch Phase												
Minimum Initial (s)		12.0	12.0	12.0	12.0					7.0		7.0
Minimum Split (s)		21.0	21.0	21.0	21.0					14.0		14.0
Total Split (s)	0.0	57.0	57.0	57.0	57.0	0.0	0.0	0.0	0.0	33.0	0.0	33.0
Total Split (%)	0.0%	63.3%	63.3%	63.3%	63.3%	0.0%	0.0%	0.0%	0.0%	36.7%	0.0%	36.7%
Maximum Green (s)		50.0	50.0	50.0	50.0					26.0		26.0
Yellow Time (s)		5.0	5.0	5.0	5.0					5.0		5.0
All-Red Time (s)		2.0	2.0	2.0	2.0					2.0		2.0
Lost Time Adjust (s)	-2.0	-2.0	-2.0	-2.0	-2.0	-2.0	-2.0	-2.0	-2.0	-2.0	-2.0	-2.0
Total Lost Time (s)	2.0	5.0	5.0	5.0	5.0	2.0	2.0	2.0	2.0	5.0	2.0	5.0
Lead/Lag												
Lead-Lag Optimize?												
Vehicle Extension (s)		3.0	3.0	3.0	3.0					3.0		3.0
Recall Mode		C-Max	C-Max	C-Max	C-Max					None		None
Act Effct Green (s)		52.0	52.0		52.0					28.0		28.0
Actuated g/C Ratio		0.58	0.58		0.58					0.31		0.31
v/c Ratio		0.58	0.26		0.81					0.23		1.05
Control Delay		14.7	10.4		22.4					24.5		86.9
Queue Delay		0.0	0.0		0.0					0.0		0.0
Total Delay		14.7	10.4		22.4					24.5		86.9
LOS		B	B		C					C		F
Approach Delay		13.6			22.4							
Approach LOS		B			C							

Lanes, Volumes, Timings
 10: SR 1783 (Upward Rd) & I-26 SB Off-Ramp

2011 Base Year - Build 8 Lanes

Timing Plan: AM Peak



Lane Group	EBL	EBT	EBR	WBL	WBT	WBR	NBL	NBT	NBR	SBL	SBT	SBR
Queue Length 50th (ft)		207	58		317					54		~324
Queue Length 95th (ft)		307	98		m#454					98		#517
Internal Link Dist (ft)		469			550			467			571	
Turn Bay Length (ft)			200									100
Base Capacity (vph)		1076	864		744					551		492
Starvation Cap Reductn		0	0		0					0		0
Spillback Cap Reductn		0	0		0					0		0
Storage Cap Reductn		0	0		0					0		0
Reduced v/c Ratio		0.58	0.26		0.81					0.23		1.05

Intersection Summary

Area Type: Other
 Cycle Length: 90
 Actuated Cycle Length: 90
 Offset: 0 (0%), Referenced to phase 2:EBT and 6:WBTL, Start of Green
 Natural Cycle: 75
 Control Type: Actuated-Coordinated
 Maximum v/c Ratio: 1.05
 Intersection Signal Delay: 34.9
 Intersection LOS: C
 Intersection Capacity Utilization 76.2%
 ICU Level of Service D
 Analysis Period (min) 15
 ~ Volume exceeds capacity, queue is theoretically infinite.
 Queue shown is maximum after two cycles.
 # 95th percentile volume exceeds capacity, queue may be longer.
 Queue shown is maximum after two cycles.
 m Volume for 95th percentile queue is metered by upstream signal.

Splits and Phases: 10: SR 1783 (Upward Rd) & I-26 SB Off-Ramp

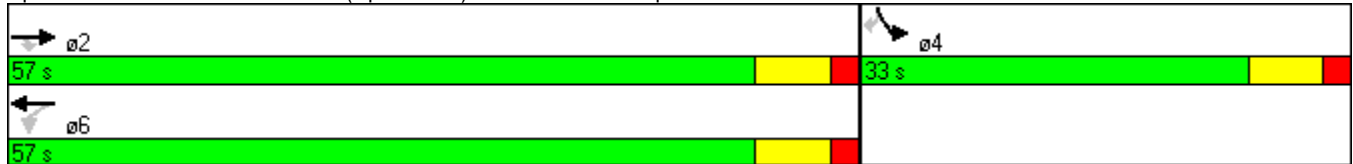

Lanes, Volumes, Timings
 1: NC 146 (Long Shoals Rd) & I-26 NB On-Ramp

2011 Base Year - Build 8 Lanes

Timing Plan: PM Peak

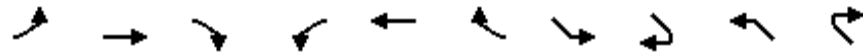

Lane Group	EBL	EBT	EBR2	WBL	WBT	WBR2	SEL	SER2	NWL	NWR2
Lane Configurations	↗↗	↑↑	↖	↗↗	↑↑	↖	↗↗	↖	↗↗	↖
Volume (vph)	234	609	190	356	456	744	783	185	188	470
Ideal Flow (vphpl)	1900	1900	1900	1900	1900	1900	1900	1900	1900	1900
Grade (%)		3%			-7%					
Storage Length (ft)	450			350			0		675	
Storage Lanes	1			2			2		1	
Taper Length (ft)	100			100			100		100	
Lane Util. Factor	0.97	0.95	1.00	0.97	0.95	1.00	0.97	1.00	0.97	1.00
Frt			0.850			0.850		0.850		0.850
Flt Protected	0.950			0.950			0.950		0.950	
Satd. Flow (prot)	3224	3452	1487	3387	3663	1562	3519	1607	3434	1599
Flt Permitted	0.950			0.950			0.950		0.950	
Satd. Flow (perm)	3224	3452	1487	3387	3663	1562	3519	1607	3434	1599
Right Turn on Red			No			No		No		No
Satd. Flow (RTOR)										
Link Speed (mph)		45			45					
Link Distance (ft)		1009			964					
Travel Time (s)		15.3			14.6					
Peak Hour Factor	0.90	0.90	0.90	0.90	0.90	0.90	0.90	0.90	0.90	0.90
Heavy Vehicles (%)	7%	3%	7%	7%	2%	7%	2%	3%	3%	2%
Adj. Flow (vph)	260	677	211	396	507	827	870	206	209	522
Shared Lane Traffic (%)										
Lane Group Flow (vph)	260	677	211	396	507	827	870	206	209	522
Turn Type	Prot		Free	Prot		Free	Prot	custom	Prot	Free
Protected Phases	5	2		1	6		4		8	
Permitted Phases			Free			Free		4		Free
Detector Phase	5	2		1	6		4	4	8	
Switch Phase										
Minimum Initial (s)	7.0	12.0		7.0	12.0		7.0	7.0	7.0	
Minimum Split (s)	16.0	20.0		15.0	21.0		16.0	16.0	15.0	
Total Split (s)	16.0	49.0	0.0	23.0	56.0	0.0	28.0	28.0	28.0	0.0
Total Split (%)	16.0%	49.0%	0.0%	23.0%	56.0%	0.0%	28.0%	28.0%	28.0%	0.0%
Maximum Green (s)	7.8	41.5		15.3	47.0		19.9	19.9	20.0	
Yellow Time (s)	3.4	4.3		4.0	5.2		3.8	3.8	3.7	
All-Red Time (s)	4.8	3.2		3.7	3.8		4.3	4.3	4.3	
Lost Time Adjust (s)	-3.2	-2.5	-2.5	-2.7	-4.0	-4.0	-3.1	-3.1	-3.0	0.0
Total Lost Time (s)	5.0	5.0	1.5	5.0	5.0	0.0	5.0	5.0	5.0	4.0
Lead/Lag	Lead	Lag		Lead	Lag					
Lead-Lag Optimize?	Yes	Yes		Yes	Yes					
Vehicle Extension (s)	2.0	6.0		2.0	6.0		2.0	2.0	2.0	
Minimum Gap (s)	3.0	3.0		3.0	3.0		3.0	3.0	3.0	
Time Before Reduce (s)	0.0	15.0		0.0	15.0		0.0	0.0	0.0	
Time To Reduce (s)	0.0	30.0		0.0	30.0		0.0	0.0	0.0	
Recall Mode	None	C-Max		None	C-Max		None	None	None	
Act Effct Green (s)	11.0	45.0	100.0	17.0	51.0	100.0	23.0	23.0	23.0	100.0
Actuated g/C Ratio	0.11	0.45	1.00	0.17	0.51	1.00	0.23	0.23	0.23	1.00
v/c Ratio	0.73	0.44	0.14	0.69	0.27	0.53	1.08	0.56	0.26	0.33
Control Delay	56.3	20.1	0.2	45.6	14.4	1.3	91.6	40.7	32.7	0.5
Queue Delay	0.0	0.0	0.0	0.0	0.0	0.0	0.0	0.0	0.0	0.0

Lanes, Volumes, Timings
 1: NC 146 (Long Shoals Rd) & I-26 NB On-Ramp

2011 Base Year - Build 8 Lanes

Timing Plan: PM Peak

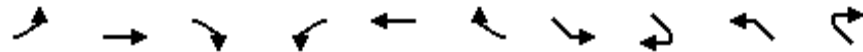

Lane Group	EBL	EBT	EBR2	WBL	WBT	WBR2	SEL	SER2	NWL	NWR2
Total Delay	56.3	20.1	0.2	45.6	14.4	1.3	91.6	40.7	32.7	0.5
LOS	E	C	A	D	B	A	F	D	C	A
Approach Delay	24.7			15.3						
Approach LOS	C			B						
Queue Length 50th (ft)	84	154	0	122	92	0	~320	117	56	0
Queue Length 95th (ft)	#137	203	0	172	125	0	#440	192	88	0
Internal Link Dist (ft)	929			884						
Turn Bay Length (ft)	450		300	350		300		425	675	575
Base Capacity (vph)	355	1553	1487	610	1868	1562	809	370	790	1599
Starvation Cap Reductn	0	0	0	0	0	0	0	0	0	0
Spillback Cap Reductn	0	0	0	0	0	0	0	0	0	0
Storage Cap Reductn	0	0	0	0	0	0	0	0	0	0
Reduced v/c Ratio	0.73	0.44	0.14	0.65	0.27	0.53	1.08	0.56	0.26	0.33

Intersection Summary

Area Type: Other
 Cycle Length: 100
 Actuated Cycle Length: 100
 Offset: 0 (0%), Referenced to phase 2:EBT and 6:WBT, Start of Green
 Natural Cycle: 60
 Control Type: Actuated-Coordinated
 Maximum v/c Ratio: 1.08
 Intersection Signal Delay: 32.0
 Intersection LOS: C
 Intersection Capacity Utilization 61.8%
 ICU Level of Service B
 Analysis Period (min) 15
 ~ Volume exceeds capacity, queue is theoretically infinite.
 Queue shown is maximum after two cycles.
 # 95th percentile volume exceeds capacity, queue may be longer.
 Queue shown is maximum after two cycles.

Splits and Phases: 1: NC 146 (Long Shoals Rd) & I-26 NB On-Ramp

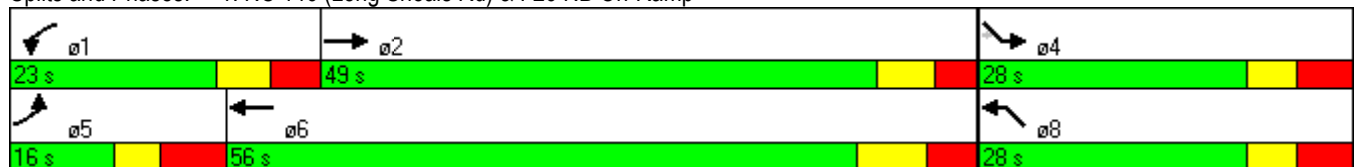

Lanes, Volumes, Timings
2: I-26 NB On-Ramp & US 25 (Asheville Highway)

2011 Base Year - Build 8 Lanes

Timing Plan: PM Peak



Lane Group	EBL	EBT	EBR	WBL	WBT	WBR	NBL	NBT	NBR	SBL	SBT	SBR
Lane Configurations				↙		↗↗	↙	↗↗			↗↗	↗
Volume (vph)	0	0	0	103	0	426	612	1076	0	0	990	246
Ideal Flow (vphpl)	1900	1900	1900	1900	1900	1900	1900	1900	1900	1900	1900	1900
Grade (%)		0%			2%			-1%			2%	
Storage Length (ft)	0		0	0		150	0		0	0		300
Storage Lanes	0		0	1		2	1		0	0		1
Taper Length (ft)	100		100	100		100	100		100	100		100
Lane Util. Factor	1.00	1.00	1.00	1.00	1.00	0.88	1.00	0.95	1.00	1.00	0.95	1.00
Frt						0.850						0.850
Flt Protected				0.950			0.950					
Satd. Flow (prot)	0	0	0	1735	0	2706	1680	3489	0	0	3436	1480
Flt Permitted				0.950			0.950					
Satd. Flow (perm)	0	0	0	1735	0	2706	1680	3489	0	0	3436	1480
Right Turn on Red			No			No			No			No
Satd. Flow (RTOR)												
Link Speed (mph)		45			35			45			45	
Link Distance (ft)		533			612			601			596	
Travel Time (s)		8.1			11.9			9.1			9.0	
Peak Hour Factor	0.90	0.90	0.90	0.90	0.90	0.90	0.90	0.90	0.90	0.90	0.90	0.90
Heavy Vehicles (%)	5%	5%	5%	3%	5%	4%	8%	4%	5%	5%	4%	8%
Adj. Flow (vph)	0	0	0	114	0	473	680	1196	0	0	1100	273
Shared Lane Traffic (%)												
Lane Group Flow (vph)	0	0	0	114	0	473	680	1196	0	0	1100	273
Turn Type				Prot		custom	Prot					Free
Protected Phases				4			5	2			6	
Permitted Phases						4						Free
Detector Phase				4		4	5	2			6	
Switch Phase												
Minimum Initial (s)				7.0		7.0	7.0	12.0			12.0	
Minimum Split (s)				13.0		13.0	14.0	19.0			18.0	
Total Split (s)	0.0	0.0	0.0	21.0	0.0	21.0	43.0	79.0	0.0	0.0	36.0	0.0
Total Split (%)	0.0%	0.0%	0.0%	21.0%	0.0%	21.0%	43.0%	79.0%	0.0%	0.0%	36.0%	0.0%
Maximum Green (s)				15.0		15.0	36.6	72.9			30.7	
Yellow Time (s)				3.7		3.7	3.0	4.6			4.3	
All-Red Time (s)				2.3		2.3	3.4	1.5			1.0	
Lost Time Adjust (s)	0.0	0.0	-2.0	-2.0	0.0	-2.0	-1.4	-1.1	0.0	-2.0	-0.3	0.0
Total Lost Time (s)	4.0	4.0	2.0	4.0	4.0	4.0	5.0	5.0	4.0	2.0	5.0	4.0
Lead/Lag							Lag				Lead	
Lead-Lag Optimize?							Yes				Yes	
Vehicle Extension (s)				2.0		2.0	2.0	8.0			8.0	
Minimum Gap (s)				3.0		3.0	3.0	5.5			5.5	
Time Before Reduce (s)				0.0		0.0	0.0	15.0			15.0	
Time To Reduce (s)				0.0		0.0	0.0	50.0			50.0	
Recall Mode				None		None	None	C-Max			C-Max	
Act Effct Green (s)				17.0		17.0	38.0	74.0			31.0	100.0
Actuated g/C Ratio				0.17		0.17	0.38	0.74			0.31	1.00
v/c Ratio				0.39		1.03	1.07	0.46			1.03	0.18
Control Delay				41.3		91.3	56.7	0.4			71.2	0.3
Queue Delay				0.0		0.0	0.0	0.3			0.0	0.0

Lanes, Volumes, Timings
 2: I-26 NB On-Ramp & US 25 (Asheville Highway)

2011 Base Year - Build 8 Lanes

Timing Plan: PM Peak



Lane Group	EBL	EBT	EBR	WBL	WBT	WBR	NBL	NBT	NBR	SBL	SBT	SBR
Total Delay				41.3		91.3	56.7	0.7			71.2	0.3
LOS				D		F	E	A			E	A
Approach Delay								21.0			57.1	
Approach LOS								C			E	
Queue Length 50th (ft)				65		~184	~501	5			~398	0
Queue Length 95th (ft)				119		#294	m#490	m4			#527	0
Internal Link Dist (ft)		453			532			521			516	
Turn Bay Length (ft)						150						300
Base Capacity (vph)				295		460	638	2582			1065	1480
Starvation Cap Reductn				0		0	0	681			0	0
Spillback Cap Reductn				0		0	0	0			0	0
Storage Cap Reductn				0		0	0	0			0	0
Reduced v/c Ratio				0.39		1.03	1.07	0.63			1.03	0.18

Intersection Summary

Area Type: Other
 Cycle Length: 100
 Actuated Cycle Length: 100
 Offset: 91 (91%), Referenced to phase 2:NBT and 6:SBT, Start of Green
 Natural Cycle: 120
 Control Type: Actuated-Coordinated
 Maximum v/c Ratio: 1.07
 Intersection Signal Delay: 43.2
 Intersection LOS: D
 Intersection Capacity Utilization 84.8%
 ICU Level of Service E
 Analysis Period (min) 15
 ~ Volume exceeds capacity, queue is theoretically infinite.
 Queue shown is maximum after two cycles.
 # 95th percentile volume exceeds capacity, queue may be longer.
 Queue shown is maximum after two cycles.
 m Volume for 95th percentile queue is metered by upstream signal.

Splits and Phases: 2: I-26 NB On-Ramp & US 25 (Asheville Highway)

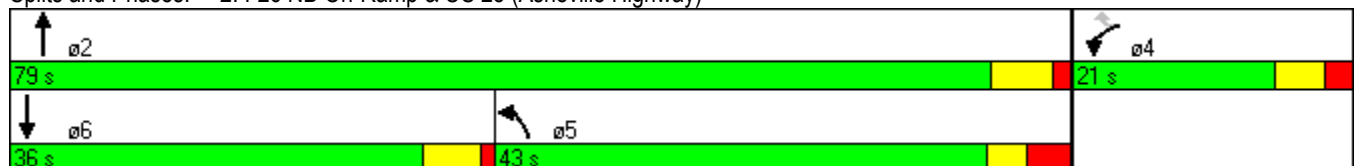

Lanes, Volumes, Timings
 3: I-26 SB Off-Ramp & US 25 (Asheville Highway)

2011 Base Year - Build 8 Lanes

Timing Plan: PM Peak



Lane Group	EBL	EBT	EBR	WBL	WBT	WBR	NBL	NBT	NBR	SBL	SBT	SBR
Lane Configurations												
Volume (vph)	251	0	495	0	0	0	0	1437	103	337	756	0
Ideal Flow (vphpl)	1900	1900	1900	1900	1900	1900	1900	1900	1900	1900	1900	1900
Grade (%)		3%			0%			4%			1%	
Storage Length (ft)	0		100	0		0	0		500	0		0
Storage Lanes	1		1	0		0	0		1	1		0
Taper Length (ft)	100		100	100		100	100		100	100		100
Lane Util. Factor	1.00	1.00	1.00	1.00	1.00	1.00	1.00	0.95	1.00	1.00	0.95	1.00
Frt			0.850						0.850			
Flt Protected	0.950									0.950		
Satd. Flow (prot)	1710	0	1544	0	0	0	0	3435	1465	1663	3487	0
Flt Permitted	0.950									0.950		
Satd. Flow (perm)	1710	0	1544	0	0	0	0	3435	1465	1663	3487	0
Right Turn on Red			Yes			No			No			No
Satd. Flow (RTOR)			233									
Link Speed (mph)		35			45			45			45	
Link Distance (ft)		471			598			795			601	
Travel Time (s)		9.2			9.1			12.0			9.1	
Peak Hour Factor	0.90	0.90	0.90	0.90	0.90	0.90	0.90	0.90	0.90	0.90	0.90	0.90
Heavy Vehicles (%)	4%	5%	3%	5%	5%	5%	5%	3%	8%	8%	3%	5%
Adj. Flow (vph)	279	0	550	0	0	0	0	1597	114	374	840	0
Shared Lane Traffic (%)												
Lane Group Flow (vph)	279	0	550	0	0	0	0	1597	114	374	840	0
Turn Type	Prot		custom							Free	Prot	
Protected Phases	4		4					2		1	6	
Permitted Phases									Free			
Detector Phase	4		4					2		1	6	
Switch Phase												
Minimum Initial (s)	7.0		7.0					12.0		7.0	12.0	
Minimum Split (s)	14.0		14.0					19.0		14.0	19.0	
Total Split (s)	25.0	0.0	25.0	0.0	0.0	0.0	0.0	49.0	0.0	26.0	75.0	0.0
Total Split (%)	25.0%	0.0%	25.0%	0.0%	0.0%	0.0%	0.0%	49.0%	0.0%	26.0%	75.0%	0.0%
Maximum Green (s)	19.0		19.0					43.3		19.5	69.3	
Yellow Time (s)	4.0		4.0					4.7		4.0	4.7	
All-Red Time (s)	2.0		2.0					1.0		2.5	1.0	
Lost Time Adjust (s)	-1.0	-2.0	-1.0	-2.0	-2.0	-2.0	-2.0	-0.7	-0.7	-1.5	-1.7	-2.0
Total Lost Time (s)	5.0	2.0	5.0	2.0	2.0	2.0	2.0	5.0	3.3	5.0	4.0	2.0
Lead/Lag								Lead		Lag		
Lead-Lag Optimize?								Yes		Yes		
Vehicle Extension (s)	2.0		2.0					8.0		2.0	8.0	
Minimum Gap (s)	3.0		3.0					5.5		3.0	5.5	
Time Before Reduce (s)	0.0		0.0					15.0		0.0	15.0	
Time To Reduce (s)	0.0		0.0					50.0		0.0	50.0	
Recall Mode	None		None					C-Max		None	C-Max	
Act Effct Green (s)	20.0		20.0					44.0	100.0	21.0	71.0	
Actuated g/C Ratio	0.20		0.20					0.44	1.00	0.21	0.71	
v/c Ratio	0.82		1.11					1.06	0.08	1.07	0.34	
Control Delay	58.4		97.7					68.4	0.1	92.5	2.2	
Queue Delay	0.0		0.0					0.0	0.0	0.0	0.0	

Lanes, Volumes, Timings
 3: I-26 SB Off-Ramp & US 25 (Asheville Highway)

2011 Base Year - Build 8 Lanes

Timing Plan: PM Peak



Lane Group	EBL	EBT	EBR	WBL	WBT	WBR	NBL	NBT	NBR	SBL	SBT	SBR
Total Delay	58.4		97.7					68.4	0.1	92.5	2.2	
LOS	E		F					E	A	F	A	
Approach Delay								63.8			30.1	
Approach LOS								E			C	
Queue Length 50th (ft)	171		~275					~590	0	~277	28	
Queue Length 95th (ft)	#306		#484					#727	0	m#279	m28	
Internal Link Dist (ft)		391			518			715			521	
Turn Bay Length (ft)			100						500			
Base Capacity (vph)	342		495					1511	1465	349	2476	
Starvation Cap Reductn	0		0					0	0	0	0	
Spillback Cap Reductn	0		0					0	0	0	0	
Storage Cap Reductn	0		0					0	0	0	0	
Reduced v/c Ratio	0.82		1.11					1.06	0.08	1.07	0.34	

Intersection Summary

Area Type: Other
 Cycle Length: 100
 Actuated Cycle Length: 100
 Offset: 0 (0%), Referenced to phase 2:NBT and 6:SBT, Start of Green
 Natural Cycle: 130
 Control Type: Actuated-Coordinated
 Maximum v/c Ratio: 1.11
 Intersection Signal Delay: 57.5
 Intersection LOS: E
 Intersection Capacity Utilization 84.8%
 ICU Level of Service E
 Analysis Period (min) 15
 ~ Volume exceeds capacity, queue is theoretically infinite.
 Queue shown is maximum after two cycles.
 # 95th percentile volume exceeds capacity, queue may be longer.
 Queue shown is maximum after two cycles.
 m Volume for 95th percentile queue is metered by upstream signal.



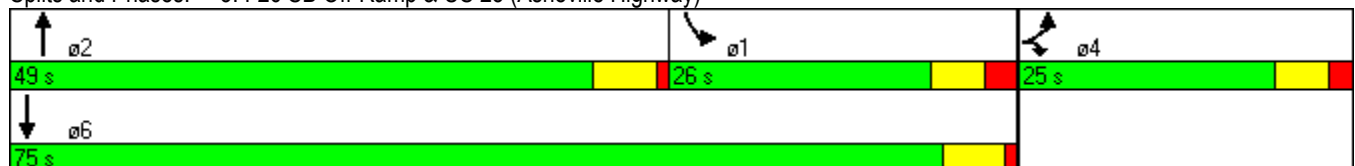



















Splits and Phases: 3: I-26 SB Off-Ramp & US 25 (Asheville Highway)



Lanes, Volumes, Timings
6: US 64 & SR 1516 (Francis Rd)

2011 Base Year - Build 8 Lanes

Timing Plan: PM Peak

												
Lane Group	EBL	EBT	EBR	WBL	WBT	WBR	NBL	NBT	NBR	SBL	SBT	SBR
Lane Configurations												
Volume (vph)	103	1919	342	53	1513	18	387	5	76	26	5	117
Ideal Flow (vphpl)	1900	1900	1900	1900	1900	1900	1900	1900	1900	1900	1900	1900
Grade (%)		-1%			4%			-1%			2%	
Storage Length (ft)	150		0	125		0	150		150	0		150
Storage Lanes	1		1	1		0	1		1	0		1
Taper Length (ft)	100		100	100		100	100		100	100		100
Lane Util. Factor	1.00	0.95	1.00	1.00	0.95	0.95	0.95	0.95	1.00	1.00	1.00	1.00
Frt			0.850		0.998				0.850			0.850
Flt Protected	0.950			0.950			0.950	0.954			0.960	
Satd. Flow (prot)	1778	3557	1591	1734	3461	0	1690	1697	1591	0	1770	1567
Flt Permitted	0.950			0.950			0.950	0.954			0.960	
Satd. Flow (perm)	1778	3557	1591	1734	3461	0	1690	1697	1591	0	1770	1567
Right Turn on Red			No			No			No			No
Satd. Flow (RTOR)												
Link Speed (mph)		45			45			35			35	
Link Distance (ft)		836			622			375			406	
Travel Time (s)		12.7			9.4			7.3			7.9	
Peak Hour Factor	0.90	0.90	0.90	0.90	0.90	0.90	0.90	0.90	0.90	0.90	0.90	0.90
Heavy Vehicles (%)	2%	2%	2%	2%	2%	2%	2%	2%	2%	2%	2%	2%
Adj. Flow (vph)	114	2132	380	59	1681	20	430	6	84	29	6	130
Shared Lane Traffic (%)							49%					
Lane Group Flow (vph)	114	2132	380	59	1701	0	219	217	84	0	35	130
Turn Type	Prot		Perm	Prot			Split		pm+ov	Split		pm+ov
Protected Phases	5	2		1	6		4	4	1	3	3	5
Permitted Phases			2						4			3
Detector Phase	5	2	2	1	6		4	4	1	3	3	5
Switch Phase												
Minimum Initial (s)	7.0	12.0	12.0	7.0	12.0		7.0	7.0	7.0	7.0	7.0	7.0
Minimum Split (s)	13.0	18.0	18.0	13.0	18.0		14.0	14.0	13.0	14.0	14.0	13.0
Total Split (s)	18.0	97.0	97.0	13.0	92.0	0.0	26.0	26.0	13.0	14.0	14.0	18.0
Total Split (%)	12.0%	64.7%	64.7%	8.7%	61.3%	0.0%	17.3%	17.3%	8.7%	9.3%	9.3%	12.0%
Maximum Green (s)	12.4	91.0	91.0	7.6	86.4		19.4	19.4	7.6	7.5	7.5	12.4
Yellow Time (s)	3.2	4.6	4.6	3.0	4.2		3.9	3.9	3.0	3.7	3.7	3.2
All-Red Time (s)	2.4	1.4	1.4	2.4	1.4		2.7	2.7	2.4	2.8	2.8	2.4
Lost Time Adjust (s)	-0.6	-1.0	-1.0	-0.4	-0.6	-2.0	-1.6	-1.6	-0.4	-2.0	-1.5	-0.6
Total Lost Time (s)	5.0	5.0	5.0	5.0	5.0	2.0	5.0	5.0	5.0	4.5	5.0	5.0
Lead/Lag	Lead	Lag	Lag	Lead	Lag		Lag	Lag	Lead	Lead	Lead	Lead
Lead-Lag Optimize?	Yes	Yes	Yes	Yes	Yes		Yes	Yes	Yes	Yes	Yes	Yes
Vehicle Extension (s)	1.0	2.0	2.0	1.0	2.0		1.0	1.0	1.0	1.0	1.0	1.0
Recall Mode	None	C-Max	C-Max	None	C-Max		None	None	None	None	None	None
Act Effct Green (s)	12.1	95.3	95.3	7.8	91.0		20.9	20.9	33.7		8.7	19.1
Actuated g/C Ratio	0.08	0.64	0.64	0.05	0.61		0.14	0.14	0.22		0.06	0.13
v/c Ratio	0.80	0.94	0.38	0.66	0.81		0.93	0.92	0.23		0.34	0.65
Control Delay	109.0	26.1	10.4	101.5	28.0		105.7	103.2	49.5		77.3	60.4
Queue Delay	0.0	0.0	0.0	0.0	0.0		0.0	0.0	0.0		0.0	0.0
Total Delay	109.0	26.1	10.4	101.5	28.0		105.7	103.2	49.5		77.3	60.4
LOS	F	C	B	F	C		F	F	D		E	E
Approach Delay		27.4			30.4			95.6			64.0	

Lanes, Volumes, Timings
6: US 64 & SR 1516 (Francis Rd)

2011 Base Year - Build 8 Lanes

Timing Plan: PM Peak



Lane Group	EBL	EBT	EBR	WBL	WBT	WBR	NBL	NBT	NBR	SBL	SBT	SBR
Approach LOS	C			C			F			E		
Queue Length 50th (ft)	116	810	101	58	697		225	223	67		34	90
Queue Length 95th (ft)	#212	#1234	140	#127	809		#396	#391	119		73	145
Internal Link Dist (ft)	756			542			295			326		
Turn Bay Length (ft)	150			125			150		150			150
Base Capacity (vph)	154	2260	1011	92	2099		239	240	360		106	209
Starvation Cap Reductn	0	0	0	0	0		0	0	0		0	0
Spillback Cap Reductn	0	0	0	0	0		0	0	0		0	0
Storage Cap Reductn	0	0	0	0	0		0	0	0		0	0
Reduced v/c Ratio	0.74	0.94	0.38	0.64	0.81		0.92	0.90	0.23		0.33	0.62

Intersection Summary

Area Type: Other
 Cycle Length: 150
 Actuated Cycle Length: 150
 Offset: 19 (13%), Referenced to phase 2:EBT and 6:WBT, Start of Green
 Natural Cycle: 130
 Control Type: Actuated-Coordinated
 Maximum v/c Ratio: 0.94
 Intersection Signal Delay: 36.7
 Intersection LOS: D
 Intersection Capacity Utilization 88.9%
 ICU Level of Service E
 Analysis Period (min) 15
 # 95th percentile volume exceeds capacity, queue may be longer.
 Queue shown is maximum after two cycles.

Splits and Phases: 6: US 64 & SR 1516 (Francis Rd)

13 s	97 s	14 s	26 s
18 s	92 s		

Lanes, Volumes, Timings
7: US 64 & I-26 SB Off-Ramp

2011 Base Year - Build 8 Lanes

Timing Plan: PM Peak

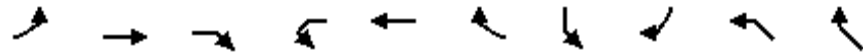

Lane Group	EBL	EBT	EBR	WBL	WBT	WBR	SBL	SBR	NWL	NWR
Lane Configurations		↑↑	↑		↑↑			↑↑		
Volume (vph)	0	1902	221	0	1357	0	0	353	0	0
Ideal Flow (vphpl)	1900	1900	1900	1900	1900	1900	1900	1900	1900	1900
Grade (%)		3%			-3%		-3%		0%	
Storage Length (ft)	0		0	0		0	0	500	0	0
Storage Lanes	0		1	0		0	0	1	0	0
Taper Length (ft)	100		100	100		100	100	100	100	100
Lane Util. Factor	1.00	0.95	1.00	1.00	0.95	1.00	1.00	0.88	1.00	1.00
Frt			0.850					0.850		
Flt Protected										
Satd. Flow (prot)	0	3486	1473	0	3592	0	0	2828	0	0
Flt Permitted										
Satd. Flow (perm)	0	3486	1473	0	3592	0	0	2828	0	0
Right Turn on Red			No			No		No		
Satd. Flow (RTOR)										
Link Speed (mph)		45			45		35		45	
Link Distance (ft)		728			745		807		350	
Travel Time (s)		11.0			11.3		15.7		5.3	
Peak Hour Factor	0.90	0.90	0.90	0.90	0.90	0.90	0.90	0.90	0.90	0.90
Heavy Vehicles (%)	5%	2%	8%	5%	2%	5%	5%	2%	5%	5%
Adj. Flow (vph)	0	2113	246	0	1508	0	0	392	0	0
Shared Lane Traffic (%)										
Lane Group Flow (vph)	0	2113	246	0	1508	0	0	392	0	0
Turn Type			Perm					custom		
Protected Phases		Free			6			4		
Permitted Phases			Free							
Detector Phase					6			4		
Switch Phase										
Minimum Initial (s)					12.0			7.0		
Minimum Split (s)					18.0			13.0		
Total Split (s)	0.0	0.0	0.0	0.0	107.0	0.0	0.0	43.0	0.0	0.0
Total Split (%)	0.0%	0.0%	0.0%	0.0%	71.3%	0.0%	0.0%	28.7%	0.0%	0.0%
Maximum Green (s)					101.2			37.9		
Yellow Time (s)					4.8			4.1		
All-Red Time (s)					1.0			1.0		
Lost Time Adjust (s)	0.0	0.0	0.0	0.0	-0.8	0.0	0.0	-0.1	-2.0	0.0
Total Lost Time (s)	4.0	4.0	4.0	4.0	5.0	4.0	4.0	5.0	2.0	4.0
Lead/Lag										
Lead-Lag Optimize?										
Vehicle Extension (s)					2.0			1.0		
Recall Mode					C-Max			None		
Act Effct Green (s)		150.0	150.0		115.5			24.5		
Actuated g/C Ratio		1.00	1.00		0.77			0.16		
v/c Ratio		0.61	0.17		0.55			0.85		
Control Delay		0.2	0.1		9.1			77.7		
Queue Delay		0.0	0.0		0.0			0.0		
Total Delay		0.2	0.1		9.1			77.7		
LOS		A	A		A			E		
Approach Delay		0.2			9.1					

Lanes, Volumes, Timings
7: US 64 & I-26 SB Off-Ramp

2011 Base Year - Build 8 Lanes

Timing Plan: PM Peak

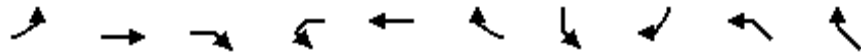

Lane Group	EBL	EBT	EBR	WBL	WBT	WBR	SBL	SBR	NWL	NWR
Approach LOS		A			A					
Queue Length 50th (ft)		0	0		271			214		
Queue Length 95th (ft)		m0	m0		370			268		
Internal Link Dist (ft)		648			665		727		270	
Turn Bay Length (ft)								500		
Base Capacity (vph)		3486	1473		2765			716		
Starvation Cap Reductn		0	0		0			0		
Spillback Cap Reductn		0	0		0			0		
Storage Cap Reductn		0	0		0			0		
Reduced v/c Ratio		0.61	0.17		0.55			0.55		

Intersection Summary

Area Type: Other
 Cycle Length: 150
 Actuated Cycle Length: 150
 Offset: 0 (0%), Referenced to phase 6:WBT, Start of Green, Master Intersection
 Natural Cycle: 45
 Control Type: Actuated-Coordinated
 Maximum v/c Ratio: 0.85
 Intersection Signal Delay: 10.5
 Intersection LOS: B
 Intersection Capacity Utilization 94.6%
 ICU Level of Service F
 Analysis Period (min) 15
 m Volume for 95th percentile queue is metered by upstream signal.

Splits and Phases: 7: US 64 & I-26 SB Off-Ramp



Lanes, Volumes, Timings
8: US 64 & SR 1634 (Carolina Village Rd)

2011 Base Year - Build 8 Lanes
Timing Plan: PM Peak



Lane Group	EBL	EBT	EBR	WBL	WBT	WBR	NBL	NBT	NBR	SBL	SBT	SBR
Lane Configurations												
Volume (vph)	73	1846	61	112	1494	122	64	22	145	110	15	53
Ideal Flow (vphpl)	1900	1900	1900	1900	1900	1900	1900	1900	1900	1900	1900	1900
Grade (%)		1%			-3%			3%			-1%	
Storage Length (ft)	100		0	100		0	0		0	0		150
Storage Lanes	1		0	1		1	0		0	0		1
Taper Length (ft)	100		100	100		100	100		100	100		100
Lane Util. Factor	1.00	0.95	0.95	1.00	0.95	1.00	1.00	1.00	1.00	1.00	1.00	1.00
Frt		0.995				0.850		0.915				0.850
Flt Protected	0.950			0.950				0.986			0.958	
Satd. Flow (prot)	1761	3504	0	1796	3592	1607	0	1655	0	0	1793	1591
Flt Permitted	0.950			0.950				0.738			0.428	
Satd. Flow (perm)	1761	3504	0	1796	3592	1607	0	1239	0	0	801	1591
Right Turn on Red			No			No			No			No
Satd. Flow (RTOR)												
Link Speed (mph)		45			45			30			30	
Link Distance (ft)		560			728			219			359	
Travel Time (s)		8.5			11.0			5.0			8.2	
Peak Hour Factor	0.90	0.90	0.90	0.90	0.90	0.90	0.90	0.90	0.90	0.90	0.90	0.90
Heavy Vehicles (%)	2%	2%	2%	2%	2%	2%	2%	2%	2%	2%	2%	2%
Adj. Flow (vph)	81	2051	68	124	1660	136	71	24	161	122	17	59
Shared Lane Traffic (%)												
Lane Group Flow (vph)	81	2119	0	124	1660	136	0	256	0	0	139	59
Turn Type	Prot			Prot		Perm	Perm			Perm		pm+ov
Protected Phases	5	2		1	6			8			4	5
Permitted Phases						6	8			4		4
Detector Phase	5	2		1	6	6	8	8		4	4	5
Switch Phase												
Minimum Initial (s)	7.0	12.0		7.0	12.0	12.0	7.0	7.0		7.0	7.0	7.0
Minimum Split (s)	13.0	18.0		13.0	19.0	19.0	13.0	13.0		13.0	13.0	13.0
Total Split (s)	20.0	98.0	0.0	16.0	94.0	94.0	36.0	36.0	0.0	36.0	36.0	20.0
Total Split (%)	13.3%	65.3%	0.0%	10.7%	62.7%	62.7%	24.0%	24.0%	0.0%	24.0%	24.0%	13.3%
Maximum Green (s)	14.1	92.4		10.6	87.8	87.8	30.2	30.2		30.1	30.1	14.1
Yellow Time (s)	3.0	4.4		3.0	4.8	4.8	3.4	3.4		3.6	3.6	3.0
All-Red Time (s)	2.9	1.2		2.4	1.4	1.4	2.4	2.4		2.3	2.3	2.9
Lost Time Adjust (s)	-0.9	-0.6	-2.0	-0.4	-1.2	-1.2	-2.0	-0.8	-2.0	-2.0	-0.9	-0.9
Total Lost Time (s)	5.0	5.0	2.0	5.0	5.0	5.0	3.8	5.0	2.0	3.9	5.0	5.0
Lead/Lag	Lag	Lag		Lead	Lead	Lead						Lag
Lead-Lag Optimize?	Yes	Yes		Yes	Yes	Yes						Yes
Vehicle Extension (s)	1.0	2.0		1.0	2.0	2.0	1.0	1.0		1.0	1.0	1.0
Recall Mode	None	C-Max		None	C-Max	C-Max	None	None		None	None	None
Act Effct Green (s)	15.0	93.0		11.0	89.0	89.0		31.0			31.0	51.0
Actuated g/C Ratio	0.10	0.62		0.07	0.59	0.59		0.21			0.21	0.34
v/c Ratio	0.46	0.98		0.94	0.78	0.14		1.00			0.84	0.11
Control Delay	72.8	41.9		127.7	17.8	9.3		114.7			94.6	34.7
Queue Delay	0.0	0.0		0.0	0.4	0.0		0.0			0.0	0.0
Total Delay	72.8	41.9		127.7	18.2	9.3		114.7			94.6	34.7
LOS	E	D		F	B	A		F			F	C
Approach Delay		43.0			24.7			114.7			76.8	

Lanes, Volumes, Timings
 8: US 64 & SR 1634 (Carolina Village Rd)

2011 Base Year - Build 8 Lanes

Timing Plan: PM Peak



Lane Group	EBL	EBT	EBR	WBL	WBT	WBR	NBL	NBT	NBR	SBL	SBT	SBR
Approach LOS	D			C			F			E		
Queue Length 50th (ft)	76	1000		122	506	41		253		132		40
Queue Length 95th (ft)	135	#1232		#259	513	69		#444		#260		76
Internal Link Dist (ft)		480			648			139			279	
Turn Bay Length (ft)	100			100								150
Base Capacity (vph)	176	2172		132	2131	953		256		166		541
Starvation Cap Reductn	0	0		0	137	0		0		0		0
Spillback Cap Reductn	0	0		0	0	0		0		0		0
Storage Cap Reductn	0	0		0	0	0		0		0		0
Reduced v/c Ratio	0.46	0.98		0.94	0.83	0.14		1.00		0.84		0.11

Intersection Summary

Area Type: Other
 Cycle Length: 150
 Actuated Cycle Length: 150
 Offset: 118 (79%), Referenced to phase 2:EBT and 6:WBT, Start of Green
 Natural Cycle: 120
 Control Type: Actuated-Coordinated
 Maximum v/c Ratio: 1.00
 Intersection Signal Delay: 40.8
 Intersection LOS: D
 Intersection Capacity Utilization 92.0%
 ICU Level of Service F
 Analysis Period (min) 15
 # 95th percentile volume exceeds capacity, queue may be longer.
 Queue shown is maximum after two cycles.

Splits and Phases: 8: US 64 & SR 1634 (Carolina Village Rd)

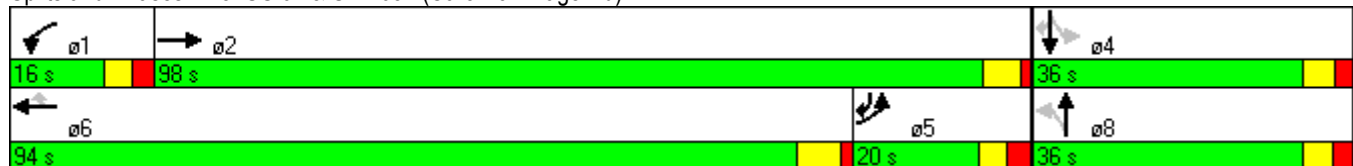

Lanes, Volumes, Timings
 9: SR 1783 (Upward Rd) & I-26 NB On-Ramp

2011 Base Year - Build 8 Lanes

Timing Plan: PM Peak



Lane Group	EBL	EBT	EBR	WBL	WBT	WBR	NBL	NBT	NBR	SBL	SBT	SBR
Lane Configurations		↕			↑	↗	↗		↗			
Volume (vph)	465	372	0	0	257	115	200	0	84	0	0	0
Ideal Flow (vphpl)	1900	1900	1900	1900	1900	1900	1900	1900	1900	1900	1900	1900
Storage Length (ft)	0		0	0		50	150		0	0		0
Storage Lanes	0		0	0		1	1		1	0		0
Taper Length (ft)	100		100	100		100	100		100	100		100
Lane Util. Factor	1.00	1.00	1.00	1.00	1.00	1.00	1.00	1.00	1.00	1.00	1.00	1.00
Fr _t						0.850			0.850			
Fl _t Protected		0.973					0.950					
Satd. Flow (prot)	0	1755	0	0	1863	1495	1770	0	1583	0	0	0
Fl _t Permitted		0.678					0.950					
Satd. Flow (perm)	0	1223	0	0	1863	1495	1770	0	1583	0	0	0
Right Turn on Red			No			No			No			No
Satd. Flow (RTOR)												
Link Speed (mph)		45			45			45				45
Link Distance (ft)		630			322			446				658
Travel Time (s)		9.5			4.9			6.8				10.0
Peak Hour Factor	0.90	0.90	0.90	0.90	0.90	0.90	0.90	0.90	0.90	0.90	0.90	0.90
Heavy Vehicles (%)	8%	2%	5%	5%	2%	8%	2%	5%	2%	5%	5%	5%
Adj. Flow (vph)	517	413	0	0	286	128	222	0	93	0	0	0
Shared Lane Traffic (%)												
Lane Group Flow (vph)	0	930	0	0	286	128	222	0	93	0	0	0
Turn Type	Perm					Perm	Prot		custom			
Protected Phases		2			6		8					
Permitted Phases	2					6			8			
Detector Phase	2	2			6	6	8		8			
Switch Phase												
Minimum Initial (s)	12.0	12.0			12.0	12.0	7.0		7.0			
Minimum Split (s)	21.0	21.0			21.0	21.0	14.0		14.0			
Total Split (s)	74.0	74.0	0.0	0.0	74.0	74.0	16.0	0.0	16.0	0.0	0.0	0.0
Total Split (%)	82.2%	82.2%	0.0%	0.0%	82.2%	82.2%	17.8%	0.0%	17.8%	0.0%	0.0%	0.0%
Maximum Green (s)	67.0	67.0			67.0	67.0	9.0		9.0			
Yellow Time (s)	5.0	5.0			5.0	5.0	5.0		5.0			
All-Red Time (s)	2.0	2.0			2.0	2.0	2.0		2.0			
Lost Time Adjust (s)	-2.0	-2.0	-2.0	-2.0	-2.0	-2.0	-2.0	-2.0	-2.0	-2.0	-2.0	-2.0
Total Lost Time (s)	5.0	5.0	2.0	2.0	5.0	5.0	5.0	2.0	5.0	2.0	2.0	2.0
Lead/Lag												
Lead-Lag Optimize?												
Vehicle Extension (s)	3.0	3.0			3.0	3.0	3.0		3.0			
Recall Mode	C-Max	C-Max			C-Max	C-Max	None		None			
Act Effct Green (s)		69.0			69.0	69.0	11.0		11.0			
Actuated g/C Ratio		0.77			0.77	0.77	0.12		0.12			
v/c Ratio		0.99			0.20	0.11	1.03		0.48			
Control Delay		34.1			3.3	2.9	110.0		46.0			
Queue Delay		4.4			0.0	0.0	0.0		0.0			
Total Delay		38.6			3.3	2.9	110.0		46.0			
LOS		D			A	A	F		D			
Approach Delay		38.6			3.2							
Approach LOS		D			A							

Lanes, Volumes, Timings
 9: SR 1783 (Upward Rd) & I-26 NB On-Ramp

2011 Base Year - Build 8 Lanes

Timing Plan: PM Peak



Lane Group	EBL	EBT	EBR	WBL	WBT	WBR	NBL	NBT	NBR	SBL	SBT	SBR
Queue Length 50th (ft)		514			35	15	~136		50			
Queue Length 95th (ft)		#783			56	27	#276		99			
Internal Link Dist (ft)		550			242			366			578	
Turn Bay Length (ft)						50	150					
Base Capacity (vph)		938			1428	1146	216		193			
Starvation Cap Reductn		17			0	0	0		0			
Spillback Cap Reductn		0			0	0	0		0			
Storage Cap Reductn		0			0	0	0		0			
Reduced v/c Ratio		1.01			0.20	0.11	1.03		0.48			

Intersection Summary

Area Type: Other
 Cycle Length: 90
 Actuated Cycle Length: 90
 Offset: 13 (14%), Referenced to phase 2:EBTL and 6:WBT, Start of Green
 Natural Cycle: 90
 Control Type: Actuated-Coordinated
 Maximum v/c Ratio: 1.03
 Intersection Signal Delay: 39.7
 Intersection LOS: D
 Intersection Capacity Utilization 81.6%
 ICU Level of Service D
 Analysis Period (min) 15
 ~ Volume exceeds capacity, queue is theoretically infinite.
 Queue shown is maximum after two cycles.
 # 95th percentile volume exceeds capacity, queue may be longer.
 Queue shown is maximum after two cycles.

Splits and Phases: 9: SR 1783 (Upward Rd) & I-26 NB On-Ramp

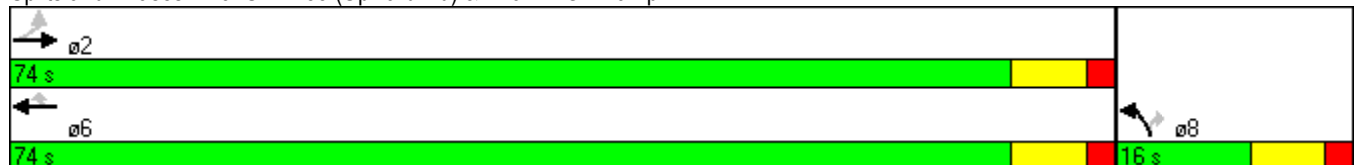

Lanes, Volumes, Timings
 10: SR 1783 (Upward Rd) & I-26 SB Off-Ramp

2011 Base Year - Build 8 Lanes

Timing Plan: PM Peak



Lane Group	EBL	EBT	EBR	WBL	WBT	WBR	NBL	NBT	NBR	SBL	SBT	SBR
Lane Configurations		↑	↗		↖					↘		↗
Volume (vph)	0	718	204	65	392	0	0	0	0	119	0	367
Ideal Flow (vphpl)	1900	1900	1900	1900	1900	1900	1900	1900	1900	1900	1900	1900
Storage Length (ft)	0		200	0		0	0		0	0		100
Storage Lanes	0		1	0		0	0		0	1		1
Taper Length (ft)	100		100	100		100	100		100	100		100
Lane Util. Factor	1.00	1.00	1.00	1.00	1.00	1.00	1.00	1.00	1.00	1.00	1.00	1.00
Fr _t			0.850									0.850
Fl _t Protected					0.993					0.950		
Satd. Flow (prot)	0	1863	1495	0	1834	0	0	0	0	1770	0	1583
Fl _t Permitted					0.628					0.950		
Satd. Flow (perm)	0	1863	1495	0	1160	0	0	0	0	1770	0	1583
Right Turn on Red			No			No			No			No
Satd. Flow (RTOR)												
Link Speed (mph)		45			45			45			45	
Link Distance (ft)		549			630			547			651	
Travel Time (s)		8.3			9.5			8.3			9.9	
Peak Hour Factor	0.90	0.90	0.90	0.90	0.90	0.90	0.90	0.90	0.90	0.90	0.90	0.90
Heavy Vehicles (%)	5%	2%	8%	8%	2%	5%	5%	5%	5%	2%	5%	2%
Adj. Flow (vph)	0	798	227	72	436	0	0	0	0	132	0	408
Shared Lane Traffic (%)												
Lane Group Flow (vph)	0	798	227	0	508	0	0	0	0	132	0	408
Turn Type			Perm	Perm						Prot		custom
Protected Phases		2			6					4		
Permitted Phases			2	6								4
Detector Phase		2	2	6	6					4		4
Switch Phase												
Minimum Initial (s)		12.0	12.0	12.0	12.0					7.0		7.0
Minimum Split (s)		21.0	21.0	21.0	21.0					14.0		14.0
Total Split (s)	0.0	59.0	59.0	59.0	59.0	0.0	0.0	0.0	0.0	31.0	0.0	31.0
Total Split (%)	0.0%	65.6%	65.6%	65.6%	65.6%	0.0%	0.0%	0.0%	0.0%	34.4%	0.0%	34.4%
Maximum Green (s)		52.0	52.0	52.0	52.0					24.0		24.0
Yellow Time (s)		5.0	5.0	5.0	5.0					5.0		5.0
All-Red Time (s)		2.0	2.0	2.0	2.0					2.0		2.0
Lost Time Adjust (s)	-2.0	-2.0	-2.0	-2.0	-2.0	-2.0	-2.0	-2.0	-2.0	-2.0	-2.0	-2.0
Total Lost Time (s)	2.0	5.0	5.0	5.0	5.0	2.0	2.0	2.0	2.0	5.0	2.0	5.0
Lead/Lag												
Lead-Lag Optimize?												
Vehicle Extension (s)		3.0	3.0	3.0	3.0					3.0		3.0
Recall Mode		C-Max	C-Max	C-Max	C-Max					None		None
Act Effct Green (s)		54.5	54.5		54.5					25.5		25.5
Actuated g/C Ratio		0.61	0.61		0.61					0.28		0.28
v/c Ratio		0.71	0.25		0.72					0.26		0.91
Control Delay		16.8	9.3		17.0					26.5		57.8
Queue Delay		0.5	0.0		0.0					0.1		0.0
Total Delay		17.3	9.3		17.0					26.5		57.8
LOS		B	A		B					C		E
Approach Delay		15.5			17.0							
Approach LOS		B			B							

Lanes, Volumes, Timings
 10: SR 1783 (Upward Rd) & I-26 SB Off-Ramp

2011 Base Year - Build 8 Lanes

Timing Plan: PM Peak



Lane Group	EBL	EBT	EBR	WBL	WBT	WBR	NBL	NBT	NBR	SBL	SBT	SBR
Queue Length 50th (ft)		291	56		263					57		221
Queue Length 95th (ft)		434	94		m324					105		#391
Internal Link Dist (ft)		469			550			467			571	
Turn Bay Length (ft)			200									100
Base Capacity (vph)		1128	905		702					511		457
Starvation Cap Reductn		0	0		0					0		0
Spillback Cap Reductn		87	0		0					43		0
Storage Cap Reductn		0	0		0					0		0
Reduced v/c Ratio		0.77	0.25		0.72					0.28		0.89

Intersection Summary

Area Type: Other
 Cycle Length: 90
 Actuated Cycle Length: 90
 Offset: 4 (4%), Referenced to phase 2:EBT and 6:WBTL, Start of Green
 Natural Cycle: 65
 Control Type: Actuated-Coordinated
 Maximum v/c Ratio: 0.91
 Intersection Signal Delay: 24.9
 Intersection LOS: C
 Intersection Capacity Utilization 80.3%
 ICU Level of Service D
 Analysis Period (min) 15
 # 95th percentile volume exceeds capacity, queue may be longer.
 Queue shown is maximum after two cycles.
 m Volume for 95th percentile queue is metered by upstream signal.

Splits and Phases: 10: SR 1783 (Upward Rd) & I-26 SB Off-Ramp

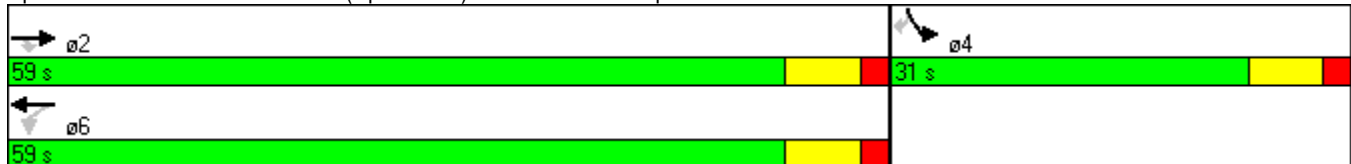

2040 No-Build

Lanes, Volumes, Timings
 1: NC 146 (Long Shoals Rd) & I-26 NB On-Ramp

2040 Design Year - No Build

Timing Plan: AM Peak

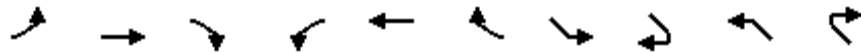

Lane Group	EBL	EBT	EBR2	WBL	WBT	WBR2	SEL	SER2	NWL	NWR2
Lane Configurations	↗↗	↑↑	↖	↗↗	↑↑	↖	↗↗	↖	↗↗	↖
Volume (vph)	308	884	307	494	1162	842	815	392	310	379
Ideal Flow (vphpl)	1900	1900	1900	1900	1900	1900	1900	1900	1900	1900
Grade (%)		3%			-7%					
Storage Length (ft)	450			350			0		675	
Storage Lanes	1			2			2		1	
Taper Length (ft)	100			100			100		100	
Lane Util. Factor	0.97	0.95	1.00	0.97	0.95	1.00	0.97	1.00	0.97	1.00
Frt			0.850			0.850		0.850		0.850
Flt Protected	0.950			0.950			0.950		0.950	
Satd. Flow (prot)	3224	3452	1487	3387	3663	1562	3519	1607	3434	1599
Flt Permitted	0.950			0.950			0.950		0.950	
Satd. Flow (perm)	3224	3452	1487	3387	3663	1562	3519	1607	3434	1599
Right Turn on Red			No			No		No		No
Satd. Flow (RTOR)										
Link Speed (mph)		45			45					
Link Distance (ft)		1009			964					
Travel Time (s)		15.3			14.6					
Peak Hour Factor	0.90	0.90	0.90	0.90	0.90	0.90	0.90	0.90	0.90	0.90
Heavy Vehicles (%)	7%	3%	7%	7%	2%	7%	2%	3%	3%	2%
Adj. Flow (vph)	342	982	341	549	1291	936	906	436	344	421
Shared Lane Traffic (%)										
Lane Group Flow (vph)	342	982	341	549	1291	936	906	436	344	421
Turn Type	Prot		Free	Prot		Free	Prot	custom	Prot	Free
Protected Phases	5	2		1	6		4		8	
Permitted Phases			Free			Free		4		Free
Detector Phase	5	2		1	6		4	4	8	
Switch Phase										
Minimum Initial (s)	7.0	12.0		7.0	12.0		7.0	7.0	7.0	
Minimum Split (s)	16.0	20.0		15.0	21.0		16.0	16.0	15.0	
Total Split (s)	18.0	39.0	0.0	24.0	45.0	0.0	37.0	37.0	37.0	0.0
Total Split (%)	18.0%	39.0%	0.0%	24.0%	45.0%	0.0%	37.0%	37.0%	37.0%	0.0%
Maximum Green (s)	9.8	31.5		16.3	36.0		28.9	28.9	29.0	
Yellow Time (s)	3.4	4.3		4.0	5.2		3.8	3.8	3.7	
All-Red Time (s)	4.8	3.2		3.7	3.8		4.3	4.3	4.3	
Lost Time Adjust (s)	-3.2	-2.5	-2.5	-2.7	-4.0	-4.0	-3.1	-3.1	-3.0	0.0
Total Lost Time (s)	5.0	5.0	1.5	5.0	5.0	0.0	5.0	5.0	5.0	4.0
Lead/Lag	Lead	Lag		Lead	Lag					
Lead-Lag Optimize?	Yes	Yes		Yes	Yes					
Vehicle Extension (s)	2.0	6.0		2.0	6.0		2.0	2.0	2.0	
Minimum Gap (s)	3.0	3.0		3.0	3.0		3.0	3.0	3.0	
Time Before Reduce (s)	0.0	15.0		0.0	15.0		0.0	0.0	0.0	
Time To Reduce (s)	0.0	30.0		0.0	30.0		0.0	0.0	0.0	
Recall Mode	None	C-Max		None	C-Max		None	None	None	
Act Effct Green (s)	13.2	35.2	100.0	18.9	40.8	100.0	30.9	30.9	30.9	100.0
Actuated g/C Ratio	0.13	0.35	1.00	0.19	0.41	1.00	0.31	0.31	0.31	1.00
v/c Ratio	0.80	0.81	0.23	0.86	0.86	0.60	0.83	0.88	0.32	0.26
Control Delay	57.6	36.2	0.4	53.8	34.7	1.7	39.7	52.8	27.2	0.4
Queue Delay	0.0	0.0	0.0	0.0	0.0	0.0	0.0	0.0	0.0	0.0

Lanes, Volumes, Timings
 1: NC 146 (Long Shoals Rd) & I-26 NB On-Ramp

2040 Design Year - No Build
 Timing Plan: AM Peak

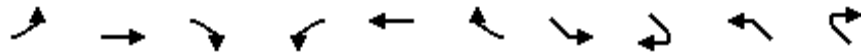

Lane Group	EBL	EBT	EBR2	WBL	WBT	WBR2	SEL	SER2	NWL	NWR2
Total Delay	57.6	36.2	0.4	53.8	34.7	1.7	39.7	52.8	27.2	0.4
LOS	E	D	A	D	C	A	D	D	C	A
Approach Delay	33.2			27.4						
Approach LOS	C			C						
Queue Length 50th (ft)	110	301	0	175	393	0	270	258	85	0
Queue Length 95th (ft)	#180	384	0	#261	#500	0	347	#428	122	0
Internal Link Dist (ft)	929			884						
Turn Bay Length (ft)	450		300	350		300		425	675	575
Base Capacity (vph)	427	1214	1487	644	1495	1562	1126	514	1099	1599
Starvation Cap Reductn	0	0	0	0	0	0	0	0	0	0
Spillback Cap Reductn	0	0	0	0	0	0	0	0	0	0
Storage Cap Reductn	0	0	0	0	0	0	0	0	0	0
Reduced v/c Ratio	0.80	0.81	0.23	0.85	0.86	0.60	0.80	0.85	0.31	0.26

Intersection Summary

Area Type: Other
 Cycle Length: 100
 Actuated Cycle Length: 100
 Offset: 0 (0%), Referenced to phase 2:EBT and 6:WBT, Start of Green
 Natural Cycle: 80
 Control Type: Actuated-Coordinated
 Maximum v/c Ratio: 0.88
 Intersection Signal Delay: 30.5
 Intersection LOS: C
 Intersection Capacity Utilization 76.9%
 ICU Level of Service D
 Analysis Period (min) 15
 # 95th percentile volume exceeds capacity, queue may be longer.
 Queue shown is maximum after two cycles.

Splits and Phases: 1: NC 146 (Long Shoals Rd) & I-26 NB On-Ramp

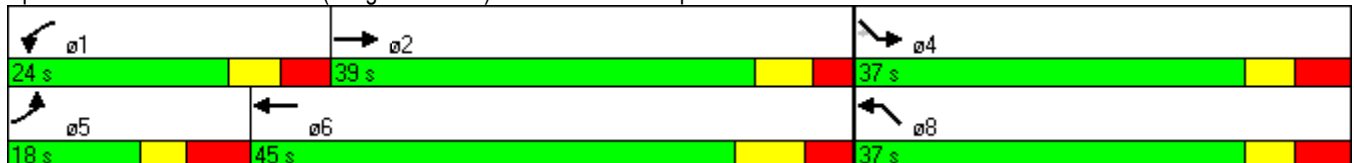

Lanes, Volumes, Timings
 2: I-26 NB On-Ramp & US 25 (Asheville Highway)

2040 Design Year - No Build

Timing Plan: AM Peak



Lane Group	EBL	EBT	EBR	WBL	WBT	WBR	NBL	NBT	NBR	SBL	SBT	SBR
Lane Configurations				↖		↗	↖	↗			↗	↖
Volume (vph)	0	0	0	287	0	406	801	1246	0	0	1802	221
Ideal Flow (vphpl)	1900	1900	1900	1900	1900	1900	1900	1900	1900	1900	1900	1900
Grade (%)		0%			2%			-1%			2%	
Storage Length (ft)	0		0	0		150	0		0	0		300
Storage Lanes	0		0	1		2	1		0	0		1
Taper Length (ft)	100		100	100		100	100		100	100		100
Lane Util. Factor	1.00	1.00	1.00	1.00	1.00	0.88	1.00	0.95	1.00	1.00	0.95	1.00
Frt						0.850						0.850
Flt Protected				0.950			0.950					
Satd. Flow (prot)	0	0	0	1735	0	2706	1680	3489	0	0	3436	1480
Flt Permitted				0.950			0.950					
Satd. Flow (perm)	0	0	0	1735	0	2706	1680	3489	0	0	3436	1480
Right Turn on Red			No			Yes			No			No
Satd. Flow (RTOR)						179						
Link Speed (mph)		45			35			45				45
Link Distance (ft)		533			612			601				596
Travel Time (s)		8.1			11.9			9.1				9.0
Peak Hour Factor	0.90	0.90	0.90	0.90	0.90	0.90	0.90	0.90	0.90	0.90	0.90	0.90
Heavy Vehicles (%)	5%	5%	5%	3%	5%	4%	8%	4%	5%	5%	4%	8%
Adj. Flow (vph)	0	0	0	319	0	451	890	1384	0	0	2002	246
Shared Lane Traffic (%)												
Lane Group Flow (vph)	0	0	0	319	0	451	890	1384	0	0	2002	246
Turn Type				Prot		custom	Prot					Free
Protected Phases				4			5	2				6
Permitted Phases						4						Free
Detector Phase				4		4	5	2				6
Switch Phase												
Minimum Initial (s)				7.0		7.0	7.0	12.0				12.0
Minimum Split (s)				13.0		13.0	14.0	19.0				18.0
Total Split (s)	0.0	0.0	0.0	20.0	0.0	20.0	42.0	90.0	0.0	0.0	48.0	0.0
Total Split (%)	0.0%	0.0%	0.0%	18.2%	0.0%	18.2%	38.2%	81.8%	0.0%	0.0%	43.6%	0.0%
Maximum Green (s)				14.0		14.0	35.6	83.9				42.7
Yellow Time (s)				3.7		3.7	3.0	4.6				4.3
All-Red Time (s)				2.3		2.3	3.4	1.5				1.0
Lost Time Adjust (s)	-2.0	0.0	0.0	-1.0	0.0	-1.0	-1.4	-1.1	0.0	0.0	-0.3	0.0
Total Lost Time (s)	2.0	4.0	4.0	5.0	4.0	5.0	5.0	5.0	4.0	4.0	5.0	4.0
Lead/Lag							Lag					Lead
Lead-Lag Optimize?							Yes					Yes
Vehicle Extension (s)				2.0		2.0	2.0	8.0				8.0
Minimum Gap (s)				3.0		3.0	3.0	5.5				5.5
Time Before Reduce (s)				0.0		0.0	0.0	15.0				15.0
Time To Reduce (s)				0.0		0.0	0.0	50.0				50.0
Recall Mode				None		None	None	C-Max				C-Max
Act Effct Green (s)				15.0		15.0	37.0	85.0				43.0
Actuated g/C Ratio				0.14		0.14	0.34	0.77				0.39
v/c Ratio				1.35		0.86	1.58	0.51				1.49
Control Delay				218.9		45.1	282.5	2.1				253.1
Queue Delay				0.0		0.0	0.0	0.7				0.0

Lanes, Volumes, Timings
 2: I-26 NB On-Ramp & US 25 (Asheville Highway)

2040 Design Year - No Build
 Timing Plan: AM Peak



Lane Group	EBL	EBT	EBR	WBL	WBT	WBR	NBL	NBT	NBR	SBL	SBT	SBR
Total Delay				218.9		45.1	282.5	2.8			253.1	0.2
LOS				F		D	F	A			F	A
Approach Delay								112.3			225.4	
Approach LOS								F			F	
Queue Length 50th (ft)				~296		109	~926	23			~1031	0
Queue Length 95th (ft)				#471		#205	m417	m6			#1170	0
Internal Link Dist (ft)		453			532			521			516	
Turn Bay Length (ft)						150						300
Base Capacity (vph)				237		524	565	2696			1343	1480
Starvation Cap Reductn				0		0	0	868			0	0
Spillback Cap Reductn				0		0	0	0			0	0
Storage Cap Reductn				0		0	0	0			0	0
Reduced v/c Ratio				1.35		0.86	1.58	0.76			1.49	0.17

Intersection Summary

Area Type: Other
 Cycle Length: 110
 Actuated Cycle Length: 110
 Offset: 49 (45%), Referenced to phase 2:NBT and 6:SBT, Start of Green
 Natural Cycle: 200
 Control Type: Actuated-Coordinated
 Maximum v/c Ratio: 1.58
 Intersection Signal Delay: 161.1
 Intersection LOS: F
 Intersection Capacity Utilization 122.6%
 ICU Level of Service H
 Analysis Period (min) 15
 ~ Volume exceeds capacity, queue is theoretically infinite.
 Queue shown is maximum after two cycles.
 # 95th percentile volume exceeds capacity, queue may be longer.
 Queue shown is maximum after two cycles.
 m Volume for 95th percentile queue is metered by upstream signal.

Splits and Phases: 2: I-26 NB On-Ramp & US 25 (Asheville Highway)

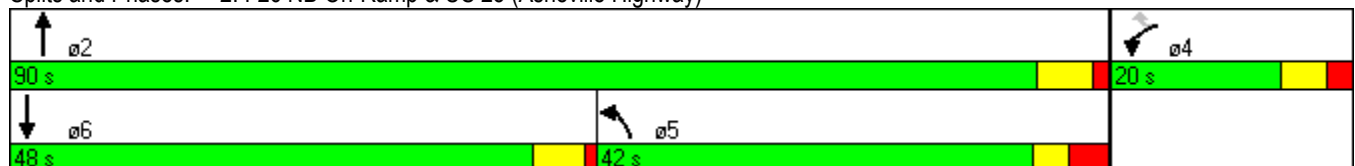

Lanes, Volumes, Timings
 3: I-26 SB Off-Ramp & US 25 (Asheville Highway)

2040 Design Year - No Build
 Timing Plan: AM Peak



Lane Group	EBL	EBT	EBR	WBL	WBT	WBR	NBL	NBT	NBR	SBL	SBT	SBR
Lane Configurations												
Volume (vph)	219	0	997	0	0	0	0	1828	285	509	1580	0
Ideal Flow (vphpl)	1900	1900	1900	1900	1900	1900	1900	1900	1900	1900	1900	1900
Grade (%)		3%			0%			4%			1%	
Storage Length (ft)	0		100	0		0	0		500	0		0
Storage Lanes	1		1	0		0	0		1	1		0
Taper Length (ft)	100		100	100		100	100		100	100		100
Lane Util. Factor	1.00	1.00	1.00	1.00	1.00	1.00	1.00	0.95	1.00	1.00	0.95	1.00
Frt			0.850						0.850			
Flt Protected	0.950									0.950		
Satd. Flow (prot)	1710	0	1544	0	0	0	0	3435	1465	1663	3487	0
Flt Permitted	0.950									0.950		
Satd. Flow (perm)	1710	0	1544	0	0	0	0	3435	1465	1663	3487	0
Right Turn on Red			No			No			No			No
Satd. Flow (RTOR)												
Link Speed (mph)		35			45			45			45	
Link Distance (ft)		471			598			795			601	
Travel Time (s)		9.2			9.1			12.0			9.1	
Peak Hour Factor	0.90	0.90	0.90	0.90	0.90	0.90	0.90	0.90	0.90	0.90	0.90	0.90
Heavy Vehicles (%)	4%	5%	3%	5%	5%	5%	5%	3%	8%	8%	3%	5%
Adj. Flow (vph)	243	0	1108	0	0	0	0	2031	317	566	1756	0
Shared Lane Traffic (%)												
Lane Group Flow (vph)	243	0	1108	0	0	0	0	2031	317	566	1756	0
Turn Type	Prot		custom						Free	Prot		
Protected Phases	4		4					2		1	6	
Permitted Phases									Free			
Detector Phase	4		4					2		1	6	
Switch Phase												
Minimum Initial (s)	7.0		7.0					12.0		7.0	12.0	
Minimum Split (s)	13.0		13.0					18.0		14.0	18.0	
Total Split (s)	43.0	0.0	43.0	0.0	0.0	0.0	0.0	42.0	0.0	25.0	67.0	0.0
Total Split (%)	39.1%	0.0%	39.1%	0.0%	0.0%	0.0%	0.0%	38.2%	0.0%	22.7%	60.9%	0.0%
Maximum Green (s)	37.0		37.0					36.3		18.5	61.3	
Yellow Time (s)	4.0		4.0					4.7		4.0	4.7	
All-Red Time (s)	2.0		2.0					1.0		2.5	1.0	
Lost Time Adjust (s)	-1.0	-2.0	-1.0	-2.0	-2.0	-2.0	-2.0	-0.7	-0.7	-1.5	-0.7	-2.0
Total Lost Time (s)	5.0	2.0	5.0	2.0	2.0	2.0	2.0	5.0	3.3	5.0	5.0	2.0
Lead/Lag								Lag		Lead		
Lead-Lag Optimize?								Yes		Yes		
Vehicle Extension (s)	2.0		2.0					8.0		2.0	8.0	
Minimum Gap (s)	3.0		3.0					5.5		3.0	5.5	
Time Before Reduce (s)	0.0		0.0					15.0		0.0	15.0	
Time To Reduce (s)	0.0		0.0					50.0		0.0	50.0	
Recall Mode	None		None					C-Max		None	C-Max	
Act Effct Green (s)	38.0		38.0					37.0	110.0	20.0	62.0	
Actuated g/C Ratio	0.35		0.35					0.34	1.00	0.18	0.56	
v/c Ratio	0.41		2.08					1.76	0.22	1.87	0.89	
Control Delay	30.1		515.2					371.4	0.3	428.5	8.5	
Queue Delay	0.0		0.0					0.0	0.0	0.0	5.0	

Lanes, Volumes, Timings
 3: I-26 SB Off-Ramp & US 25 (Asheville Highway)

2040 Design Year - No Build
 Timing Plan: AM Peak



Lane Group	EBL	EBT	EBR	WBL	WBT	WBR	NBL	NBT	NBR	SBL	SBT	SBR
Total Delay	30.1		515.2					371.4	0.3	428.5	13.6	
LOS	C		F					F	A	F	B	
Approach Delay								321.3			114.7	
Approach LOS								F			F	
Queue Length 50th (ft)	130		~1239					~1126	0	~625	62	
Queue Length 95th (ft)	202		#1491					#1265	0	m#352	m0	
Internal Link Dist (ft)		391			518			715				521
Turn Bay Length (ft)			100						500			
Base Capacity (vph)	591		533					1155	1465	302	1965	
Starvation Cap Reductn	0		0					0	0	0	165	
Spillback Cap Reductn	0		0					0	0	0	0	
Storage Cap Reductn	0		0					0	0	0	0	
Reduced v/c Ratio	0.41		2.08					1.76	0.22	1.87	0.98	

Intersection Summary

Area Type: Other
 Cycle Length: 110
 Actuated Cycle Length: 110
 Offset: 64 (58%), Referenced to phase 2:NBT and 6:SBT, Start of Green
 Natural Cycle: 240
 Control Type: Actuated-Coordinated
 Maximum v/c Ratio: 2.08
 Intersection Signal Delay: 265.6
 Intersection LOS: F
 Intersection Capacity Utilization 122.6%
 ICU Level of Service H
 Analysis Period (min) 15
 ~ Volume exceeds capacity, queue is theoretically infinite.
 Queue shown is maximum after two cycles.
 # 95th percentile volume exceeds capacity, queue may be longer.
 Queue shown is maximum after two cycles.
 m Volume for 95th percentile queue is metered by upstream signal.

Splits and Phases: 3: I-26 SB Off-Ramp & US 25 (Asheville Highway)

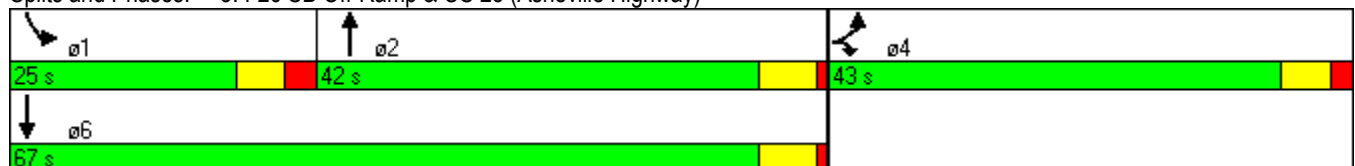

Lanes, Volumes, Timings
4: I-26 NB Ramps & Balfour Pkwy

2040 Design Year - No Build
Timing Plan: AM Peak



Lane Group	EBL	EBT	EBR	WBL	WBT	WBR	NBL	NBT	NBR	SBL	SBT	SBR
Lane Configurations			↗↗			↗	↘	↕↕			↕↕	↗
Volume (vph)	0	0	662	0	0	260	228	1412	0	0	1277	759
Ideal Flow (vphpl)	1900	1900	1900	1900	1900	1900	1900	1900	1900	1900	1900	1900
Storage Length (ft)	0		0	0		0	250		0	0		250
Storage Lanes	0		2	0		1	1		0	0		1
Taper Length (ft)	100		100	100		100	100		100	100		100
Lane Util. Factor	1.00	1.00	0.88	1.00	1.00	1.00	1.00	0.95	1.00	1.00	0.95	1.00
Frt			0.850			0.865						0.850
Flt Protected							0.950					
Satd. Flow (prot)	0	0	2787	0	0	1611	1671	3539	0	0	3539	1495
Flt Permitted							0.950					
Satd. Flow (perm)	0	0	2787	0	0	1611	1671	3539	0	0	3539	1495
Right Turn on Red			No			No			No			No
Satd. Flow (RTOR)												
Link Speed (mph)		25			45			45				45
Link Distance (ft)		393			429			690				522
Travel Time (s)		10.7			6.5			10.5				7.9
Peak Hour Factor	0.90	0.90	0.90	0.90	0.90	0.90	0.90	0.90	0.90	0.90	0.90	0.90
Heavy Vehicles (%)	5%	5%	2%	5%	5%	2%	8%	2%	5%	5%	2%	8%
Adj. Flow (vph)	0	0	736	0	0	289	253	1569	0	0	1419	843
Shared Lane Traffic (%)												
Lane Group Flow (vph)	0	0	736	0	0	289	253	1569	0	0	1419	843
Turn Type			Over			Free	Prot					Perm
Protected Phases			5				5	Free				6
Permitted Phases						Free						6
Detector Phase			5				5					6
Switch Phase												
Minimum Initial (s)			7.0				7.0				12.0	12.0
Minimum Split (s)			14.0				14.0				19.0	19.0
Total Split (s)	0.0	0.0	30.0	0.0	0.0	0.0	30.0	0.0	0.0	0.0	60.0	60.0
Total Split (%)	0.0%	0.0%	33.3%	0.0%	0.0%	0.0%	33.3%	0.0%	0.0%	0.0%	66.7%	66.7%
Maximum Green (s)			23.0				23.0				53.0	53.0
Yellow Time (s)			5.0				5.0				5.0	5.0
All-Red Time (s)			2.0				2.0				2.0	2.0
Lost Time Adjust (s)	-2.0	-2.0	-2.0	-2.0	-2.0	-2.0	-2.0	-2.0	-2.0	-2.0	-2.0	-2.0
Total Lost Time (s)	2.0	2.0	5.0	2.0	2.0	2.0	5.0	2.0	2.0	2.0	5.0	5.0
Lead/Lag			Lead				Lead				Lag	Lag
Lead-Lag Optimize?			Yes				Yes				Yes	Yes
Vehicle Extension (s)			3.0				3.0				3.0	3.0
Recall Mode			None				None				C-Max	C-Max
Act Effct Green (s)			25.0			90.0	25.0	90.0			55.0	55.0
Actuated g/C Ratio			0.28			1.00	0.28	1.00			0.61	0.61
v/c Ratio			0.95			0.18	0.55	0.44			0.66	0.92
Control Delay			55.6			0.2	25.3	0.3			13.2	33.5
Queue Delay			0.0			0.0	0.0	0.0			0.0	0.0
Total Delay			55.6			0.2	25.3	0.3			13.2	33.5
LOS			E			A	C	A			B	C
Approach Delay								3.8			20.8	
Approach LOS								A			C	

Lanes, Volumes, Timings
4: I-26 NB Ramps & Balfour Pkwy

2040 Design Year - No Build
Timing Plan: AM Peak



Lane Group	EBL	EBT	EBR	WBL	WBT	WBR	NBL	NBT	NBR	SBL	SBT	SBR
Queue Length 50th (ft)			232			0	108	0			251	390
Queue Length 95th (ft)			#359			0	m154	0			320	#686
Internal Link Dist (ft)		313			349			610			442	
Turn Bay Length (ft)							250					250
Base Capacity (vph)			774			1611	464	3539			2163	914
Starvation Cap Reductn			0			0	0	0			0	0
Spillback Cap Reductn			0			0	0	0			0	0
Storage Cap Reductn			0			0	0	0			0	0
Reduced v/c Ratio			0.95			0.18	0.55	0.44			0.66	0.92

Intersection Summary























Area Type: Other
 Cycle Length: 90
 Actuated Cycle Length: 90
 Offset: 41 (46%), Referenced to phase 6:SBT, Start of Green
 Natural Cycle: 80
 Control Type: Actuated-Coordinated
 Maximum v/c Ratio: 0.95
 Intersection Signal Delay: 18.6 Intersection LOS: B
 Intersection Capacity Utilization 68.0% ICU Level of Service C
 Analysis Period (min) 15
 # 95th percentile volume exceeds capacity, queue may be longer.
 Queue shown is maximum after two cycles.
 m Volume for 95th percentile queue is metered by upstream signal.

Splits and Phases: 4: I-26 NB Ramps & Balfour Pkwy



Lanes, Volumes, Timings
5: I-26 SB Ramps & Balfour Pkwy

2040 Design Year - No Build
Timing Plan: AM Peak

												
Lane Group	EBL	EBT	EBR	WBL	WBT	WBR	NBL	NBT	NBR	SBL	SBT	SBR
Lane Configurations						 		 			 	
Volume (vph)	0	0	304	0	0	735	0	905	641	346	1593	0
Ideal Flow (vphpl)	1900	1900	1900	1900	1900	1900	1900	1900	1900	1900	1900	1900
Storage Length (ft)	0		0	0		0	0		250	250		0
Storage Lanes	0		1	0		2	0		1	1		0
Taper Length (ft)	100		100	100		100	100		100	100		100
Lane Util. Factor	1.00	1.00	1.00	1.00	1.00	0.88	1.00	0.95	1.00	1.00	0.95	1.00
Frt			0.865			0.850			0.850			
Flt Protected										0.950		
Satd. Flow (prot)	0	0	1611	0	0	2787	0	3539	1495	1671	3539	0
Flt Permitted										0.950		
Satd. Flow (perm)	0	0	1611	0	0	2787	0	3539	1495	1671	3539	0
Right Turn on Red			No			No			No			No
Satd. Flow (RTOR)												
Link Speed (mph)		45			25			45			45	
Link Distance (ft)		642			361			480			690	
Travel Time (s)		9.7			9.8			7.3			10.5	
Peak Hour Factor	0.90	0.90	0.90	0.90	0.90	0.90	0.90	0.90	0.90	0.90	0.90	0.90
Heavy Vehicles (%)	5%	5%	2%	5%	5%	2%	5%	2%	8%	8%	2%	5%
Adj. Flow (vph)	0	0	338	0	0	817	0	1006	712	384	1770	0
Shared Lane Traffic (%)												
Lane Group Flow (vph)	0	0	338	0	0	817	0	1006	712	384	1770	0
Turn Type			Free			Over			Perm	Prot		
Protected Phases						1		2		1	Free	
Permitted Phases			Free						2			
Detector Phase						1		2	2	1		
Switch Phase												
Minimum Initial (s)						7.0		12.0	12.0	7.0		
Minimum Split (s)						14.0		19.0	19.0	14.0		
Total Split (s)	0.0	0.0	0.0	0.0	0.0	35.0	0.0	55.0	55.0	35.0	0.0	0.0
Total Split (%)	0.0%	0.0%	0.0%	0.0%	0.0%	38.9%	0.0%	61.1%	61.1%	38.9%	0.0%	0.0%
Maximum Green (s)						28.0		48.0	48.0	28.0		
Yellow Time (s)						5.0		5.0	5.0	5.0		
All-Red Time (s)						2.0		2.0	2.0	2.0		
Lost Time Adjust (s)	-2.0	-2.0	-2.0	-2.0	-2.0	-2.0	-2.0	-2.0	-2.0	-2.0	-2.0	-2.0
Total Lost Time (s)	2.0	2.0	2.0	2.0	2.0	5.0	2.0	5.0	5.0	5.0	2.0	2.0
Lead/Lag						Lead		Lag	Lag	Lead		
Lead-Lag Optimize?						Yes		Yes	Yes	Yes		
Vehicle Extension (s)						3.0		3.0	3.0	3.0		
Recall Mode						None		C-Max	C-Max	None		
Act Effct Green (s)			90.0			29.6		50.4	50.4	29.6	90.0	
Actuated g/C Ratio			1.00			0.33		0.56	0.56	0.33	1.00	
v/c Ratio			0.21			0.89		0.51	0.85	0.70	0.50	
Control Delay			0.3			42.4		13.4	28.8	25.9	0.3	
Queue Delay			0.0			0.0		0.0	0.0	0.0	0.0	
Total Delay			0.3			42.4		13.4	28.8	25.9	0.3	
LOS			A			D		B	C	C	A	
Approach Delay								19.8			4.9	
Approach LOS								B			A	

Lanes, Volumes, Timings
 5: I-26 SB Ramps & Balfour Pkwy

2040 Design Year - No Build
 Timing Plan: AM Peak



Lane Group	EBL	EBT	EBR	WBL	WBT	WBR	NBL	NBT	NBR	SBL	SBT	SBR
Queue Length 50th (ft)			0			246		174	321	175	0	
Queue Length 95th (ft)			0			#365		226	#569	m231	m0	
Internal Link Dist (ft)		562			281			400				610
Turn Bay Length (ft)									250	250		
Base Capacity (vph)			1611			929		1983	838	557	3539	
Starvation Cap Reductn			0			0		0	0	0	0	
Spillback Cap Reductn			0			0		0	0	0	0	
Storage Cap Reductn			0			0		0	0	0	0	
Reduced v/c Ratio			0.21			0.88		0.51	0.85	0.69	0.50	

Intersection Summary

Area Type: Other
 Cycle Length: 90
 Actuated Cycle Length: 90
 Offset: 0 (0%), Referenced to phase 2:NBT, Start of Green
 Natural Cycle: 65
 Control Type: Actuated-Coordinated
 Maximum v/c Ratio: 0.89
 Intersection Signal Delay: 15.8
 Intersection LOS: B
 Intersection Capacity Utilization 67.2%
 ICU Level of Service C
 Analysis Period (min) 15
 # 95th percentile volume exceeds capacity, queue may be longer.
 Queue shown is maximum after two cycles.
 m Volume for 95th percentile queue is metered by upstream signal.

Splits and Phases: 5: I-26 SB Ramps & Balfour Pkwy



Lanes, Volumes, Timings
6: US 64 & SR 1516 (Francis Rd)

2040 Design Year - No Build
Timing Plan: AM Peak



Lane Group	EBL	EBT	EBR	WBL	WBT	WBR	NBL	NBT	NBR	SBL	SBT	SBR
Lane Configurations												
Volume (vph)	161	1630	471	99	2074	33	419	5	69	23	5	143
Ideal Flow (vphpl)	1900	1900	1900	1900	1900	1900	1900	1900	1900	1900	1900	1900
Grade (%)		-1%			4%			-1%			2%	
Storage Length (ft)	150		0	125		0	150		150	0		150
Storage Lanes	1		1	1		0	1		1	0		1
Taper Length (ft)	100		100	100		100	100		100	100		100
Lane Util. Factor	1.00	0.95	1.00	1.00	0.95	0.95	0.95	0.95	1.00	1.00	1.00	1.00
Frt			0.850		0.998				0.850			0.850
Flt Protected	0.950			0.950			0.950	0.954			0.961	
Satd. Flow (prot)	1778	3557	1591	1734	3461	0	1690	1697	1591	0	1772	1567
Flt Permitted	0.950			0.950			0.950	0.954			0.961	
Satd. Flow (perm)	1778	3557	1591	1734	3461	0	1690	1697	1591	0	1772	1567
Right Turn on Red			No			No			No			No
Satd. Flow (RTOR)												
Link Speed (mph)		45			45			35			35	
Link Distance (ft)		835			622			375			406	
Travel Time (s)		12.7			9.4			7.3			7.9	
Peak Hour Factor	0.90	0.90	0.90	0.90	0.90	0.90	0.90	0.90	0.90	0.90	0.90	0.90
Heavy Vehicles (%)	2%	2%	2%	2%	2%	2%	2%	2%	2%	2%	2%	2%
Adj. Flow (vph)	179	1811	523	110	2304	37	466	6	77	26	6	159
Shared Lane Traffic (%)							49%					
Lane Group Flow (vph)	179	1811	523	110	2341	0	238	234	77	0	32	159
Turn Type	Prot		Perm	Prot			Split		pm+ov	Split		pm+ov
Protected Phases	5	2		1	6		4	4	1	3	3	5
Permitted Phases			2						4			3
Detector Phase	5	2	2	1	6		4	4	1	3	3	5
Switch Phase												
Minimum Initial (s)	7.0	12.0	12.0	7.0	12.0		7.0	7.0	7.0	7.0	7.0	7.0
Minimum Split (s)	13.0	18.0	18.0	13.0	18.0		14.0	14.0	13.0	14.0	14.0	13.0
Total Split (s)	17.0	95.0	95.0	18.0	96.0	0.0	23.0	23.0	18.0	14.0	14.0	17.0
Total Split (%)	11.3%	63.3%	63.3%	12.0%	64.0%	0.0%	15.3%	15.3%	12.0%	9.3%	9.3%	11.3%
Maximum Green (s)	11.4	89.0	89.0	12.6	90.4		16.4	16.4	12.6	7.5	7.5	11.4
Yellow Time (s)	3.2	4.6	4.6	3.0	4.2		3.9	3.9	3.0	3.7	3.7	3.2
All-Red Time (s)	2.4	1.4	1.4	2.4	1.4		2.7	2.7	2.4	2.8	2.8	2.4
Lost Time Adjust (s)	-0.6	-1.0	-1.0	-0.4	-0.6	-2.0	-1.6	-1.6	-0.4	-2.0	-1.5	-0.6
Total Lost Time (s)	5.0	5.0	5.0	5.0	5.0	2.0	5.0	5.0	5.0	4.5	5.0	5.0
Lead/Lag	Lag	Lag	Lag	Lead	Lead		Lag	Lag	Lead	Lead	Lead	Lag
Lead-Lag Optimize?	Yes	Yes	Yes	Yes	Yes		Yes	Yes	Yes	Yes	Yes	Yes
Vehicle Extension (s)	1.0	2.0	2.0	1.0	2.0		1.0	1.0	1.0	1.0	1.0	1.0
Recall Mode	None	C-Max	C-Max	None	C-Max		None	None	None	None	None	None
Act Effct Green (s)	12.0	91.3	91.3	11.7	91.0		23.7	23.7	40.5		8.7	20.3
Actuated g/C Ratio	0.08	0.61	0.61	0.08	0.61		0.16	0.16	0.27		0.06	0.14
v/c Ratio	1.26	0.84	0.54	0.81	1.11		0.89	0.87	0.18		0.31	0.75
Control Delay	206.3	18.1	13.5	106.5	88.2		93.5	90.7	45.2		76.2	82.8
Queue Delay	0.0	0.0	0.0	0.0	0.0		0.0	0.0	0.0		0.0	0.0
Total Delay	206.3	18.1	13.5	106.5	88.2		93.5	90.7	45.2		76.2	82.8
LOS	F	B	B	F	F		F	F	D		E	F
Approach Delay		30.6			89.0			85.5			81.7	

Lanes, Volumes, Timings
6: US 64 & SR 1516 (Francis Rd)

2040 Design Year - No Build
Timing Plan: AM Peak



Lane Group	EBL	EBT	EBR	WBL	WBT	WBR	NBL	NBT	NBR	SBL	SBT	SBR
Approach LOS	C			F			F			F		
Queue Length 50th (ft)	~218	399	171	107	~1378		~285	~275	60		31	146
Queue Length 95th (ft)	#380	512	216	#205	#1503		#480	#468	109		68	227
Internal Link Dist (ft)	755			542			295			326		
Turn Bay Length (ft)	150			125			150		150			150
Base Capacity (vph)	142	2164	968	150	2100		267	268	442		106	212
Starvation Cap Reductn	0	0	0	0	0		0	0	0		0	0
Spillback Cap Reductn	0	0	0	0	0		0	0	0		0	0
Storage Cap Reductn	0	0	0	0	0		0	0	0		0	0
Reduced v/c Ratio	1.26	0.84	0.54	0.73	1.11		0.89	0.87	0.17		0.30	0.75

Intersection Summary

Area Type: Other
 Cycle Length: 150
 Actuated Cycle Length: 150
 Offset: 32 (21%), Referenced to phase 2:EBT and 6:WBT, Start of Green
 Natural Cycle: 220
 Control Type: Actuated-Coordinated
 Maximum v/c Ratio: 1.26
 Intersection Signal Delay: 62.7
 Intersection Capacity Utilization 98.2%
 Analysis Period (min) 15
 Intersection LOS: E
 ICU Level of Service F

~ Volume exceeds capacity, queue is theoretically infinite.
 Queue shown is maximum after two cycles.

95th percentile volume exceeds capacity, queue may be longer.
 Queue shown is maximum after two cycles.

Splits and Phases: 6: US 64 & SR 1516 (Francis Rd)



Lanes, Volumes, Timings
7: US 64 & I-26 SB Off-Ramp

2040 Design Year - No Build
Timing Plan: AM Peak

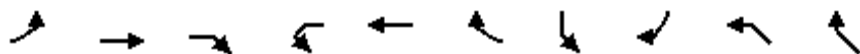

Lane Group	EBL	EBT	EBR	WBL	WBT	WBR	SBL	SBR	NWL	NWR
Lane Configurations		↑↑	↗		↑↑			↖↖		
Volume (vph)	0	1618	380	0	2007	0	0	445	0	0
Ideal Flow (vphpl)	1900	1900	1900	1900	1900	1900	1900	1900	1900	1900
Grade (%)		3%			-3%		-3%		0%	
Storage Length (ft)	0		400	0		0	0	500	0	0
Storage Lanes	0		1	0		0	0	1	0	0
Taper Length (ft)	100		100	100		100	100	100	100	100
Lane Util. Factor	1.00	0.95	1.00	1.00	0.95	1.00	1.00	0.88	1.00	1.00
Frt			0.850					0.850		
Flt Protected										
Satd. Flow (prot)	0	3486	1473	0	3592	0	0	2828	0	0
Flt Permitted										
Satd. Flow (perm)	0	3486	1473	0	3592	0	0	2828	0	0
Right Turn on Red			No			No		No		
Satd. Flow (RTOR)										
Link Speed (mph)		45			45		35		45	
Link Distance (ft)		728			791		804		308	
Travel Time (s)		11.0			12.0		15.7		4.7	
Peak Hour Factor	0.90	0.90	0.90	0.90	0.90	0.90	0.90	0.90	0.90	0.90
Heavy Vehicles (%)	5%	2%	8%	5%	2%	5%	5%	2%	5%	5%
Adj. Flow (vph)	0	1798	422	0	2230	0	0	494	0	0
Shared Lane Traffic (%)										
Lane Group Flow (vph)	0	1798	422	0	2230	0	0	494	0	0
Turn Type			Perm					custom		
Protected Phases		Free			6			4		
Permitted Phases			Free							
Detector Phase					6			4		
Switch Phase										
Minimum Initial (s)					12.0			7.0		
Minimum Split (s)					18.0			13.0		
Total Split (s)	0.0	0.0	0.0	0.0	111.0	0.0	0.0	39.0	0.0	0.0
Total Split (%)	0.0%	0.0%	0.0%	0.0%	74.0%	0.0%	0.0%	26.0%	0.0%	0.0%
Maximum Green (s)					105.2			33.9		
Yellow Time (s)					4.8			4.1		
All-Red Time (s)					1.0			1.0		
Lost Time Adjust (s)	-2.0	0.0	-2.0	-2.0	-0.8	-2.0	-2.0	-0.1	-2.0	-2.0
Total Lost Time (s)	2.0	4.0	2.0	2.0	5.0	2.0	2.0	5.0	2.0	2.0
Lead/Lag										
Lead-Lag Optimize?										
Vehicle Extension (s)					2.0			1.0		
Recall Mode					C-Max			None		
Act Effct Green (s)		150.0	150.0		110.8			29.2		
Actuated g/C Ratio		1.00	1.00		0.74			0.19		
v/c Ratio		0.52	0.29		0.84			0.90		
Control Delay		0.0	0.0		16.1			78.8		
Queue Delay		0.0	0.0		0.0			0.0		
Total Delay		0.0	0.0		16.1			78.8		
LOS		A	A		B			E		
Approach Delay		0.0			16.1					

Lanes, Volumes, Timings
7: US 64 & I-26 SB Off-Ramp

2040 Design Year - No Build

Timing Plan: AM Peak

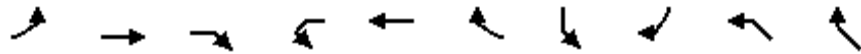

Lane Group	EBL	EBT	EBR	WBL	WBT	WBR	SBL	SBR	NWL	NWR
Approach LOS		A				B				
Queue Length 50th (ft)		0	0		511			269		
Queue Length 95th (ft)		m0	m0		m488			334		
Internal Link Dist (ft)		648			711		724		228	
Turn Bay Length (ft)			400					500		
Base Capacity (vph)		3486	1473		2654			641		
Starvation Cap Reductn		0	0		0			0		
Spillback Cap Reductn		0	0		0			0		
Storage Cap Reductn		0	0		0			0		
Reduced v/c Ratio		0.52	0.29		0.84			0.77		

Intersection Summary

Area Type: Other
 Cycle Length: 150
 Actuated Cycle Length: 150
 Offset: 0 (0%), Referenced to phase 6:WBT, Start of Green, Master Intersection
 Natural Cycle: 70
 Control Type: Actuated-Coordinated
 Maximum v/c Ratio: 0.90
 Intersection Signal Delay: 15.2
 Intersection LOS: B
 Intersection Capacity Utilization 82.7%
 ICU Level of Service E
 Analysis Period (min) 15
 m Volume for 95th percentile queue is metered by upstream signal.

Splits and Phases: 7: US 64 & I-26 SB Off-Ramp



Lanes, Volumes, Timings
8: US 64 & SR 1634 (Carolina Village Rd)

2040 Design Year - No Build
Timing Plan: AM Peak



Lane Group	EBL	EBT	EBR	WBL	WBT	WBR	NBL	NBT	NBR	SBL	SBT	SBR
Lane Configurations												
Volume (vph)	70	1593	86	243	1982	208	81	15	184	237	5	100
Ideal Flow (vphpl)	1900	1900	1900	1900	1900	1900	1900	1900	1900	1900	1900	1900
Grade (%)		1%			-3%			3%			-1%	
Storage Length (ft)	100		0	100		0	0		0	0		150
Storage Lanes	1		0	1		1	0		0	0		1
Taper Length (ft)	100		100	100		100	100		100	100		100
Lane Util. Factor	1.00	0.95	0.95	1.00	0.95	1.00	1.00	1.00	1.00	1.00	1.00	1.00
Frt		0.992				0.850		0.911				0.850
Flt Protected	0.950			0.950				0.986			0.953	
Satd. Flow (prot)	1761	3493	0	1796	3592	1607	0	1648	0	0	1784	1591
Flt Permitted	0.950			0.950				0.568			0.430	
Satd. Flow (perm)	1761	3493	0	1796	3592	1607	0	949	0	0	805	1591
Right Turn on Red			No			No			No			No
Satd. Flow (RTOR)												
Link Speed (mph)		45			45			30			30	
Link Distance (ft)		560			728			219			359	
Travel Time (s)		8.5			11.0			5.0			8.2	
Peak Hour Factor	0.90	0.90	0.90	0.90	0.90	0.90	0.90	0.90	0.90	0.90	0.90	0.90
Heavy Vehicles (%)	2%	2%	2%	2%	2%	2%	2%	2%	2%	2%	2%	2%
Adj. Flow (vph)	78	1770	96	270	2202	231	90	17	204	263	6	111
Shared Lane Traffic (%)												
Lane Group Flow (vph)	78	1866	0	270	2202	231	0	311	0	0	269	111
Turn Type	Prot			Prot		Perm	Perm			Perm		pm+ov
Protected Phases	5	2		1	6			8			4	5
Permitted Phases						6	8			4		4
Detector Phase	5	2		1	6	6	8	8		4	4	5
Switch Phase												
Minimum Initial (s)	7.0	12.0		7.0	12.0	12.0	7.0	7.0		7.0	7.0	7.0
Minimum Split (s)	13.0	18.0		13.0	19.0	19.0	13.0	13.0		13.0	13.0	13.0
Total Split (s)	13.0	78.0	0.0	24.0	89.0	89.0	48.0	48.0	0.0	48.0	48.0	13.0
Total Split (%)	8.7%	52.0%	0.0%	16.0%	59.3%	59.3%	32.0%	32.0%	0.0%	32.0%	32.0%	8.7%
Maximum Green (s)	7.1	72.4		18.6	82.8	82.8	42.2	42.2		42.1	42.1	7.1
Yellow Time (s)	3.0	4.4		3.0	4.8	4.8	3.4	3.4		3.6	3.6	3.0
All-Red Time (s)	2.9	1.2		2.4	1.4	1.4	2.4	2.4		2.3	2.3	2.9
Lost Time Adjust (s)	-0.9	-0.6	-2.0	-0.4	-1.2	-1.2	-2.0	-0.8	-2.0	-2.0	-0.9	-0.9
Total Lost Time (s)	5.0	5.0	2.0	5.0	5.0	5.0	3.8	5.0	2.0	3.9	5.0	5.0
Lead/Lag	Lag	Lag		Lead	Lead	Lead						Lag
Lead-Lag Optimize?	Yes	Yes		Yes	Yes	Yes						Yes
Vehicle Extension (s)	1.0	2.0		1.0	2.0	2.0	1.0	1.0		1.0	1.0	1.0
Recall Mode	None	C-Max		None	C-Max	C-Max	None	None		None	None	None
Act Effct Green (s)	8.0	73.0		19.0	84.0	84.0		43.0			43.0	56.0
Actuated g/C Ratio	0.05	0.49		0.13	0.56	0.56		0.29			0.29	0.37
v/c Ratio	0.83	1.10		1.19	1.09	0.26		1.14			1.16	0.19
Control Delay	123.7	90.4		160.9	76.8	17.1		146.1			157.3	32.8
Queue Delay	0.0	0.0		0.0	40.0	0.0		0.0			0.0	0.0
Total Delay	123.7	90.4		160.9	116.8	17.1		146.1			157.3	32.8
LOS	F	F		F	F	B		F			F	C
Approach Delay		91.7			112.7			146.1			120.9	

Lanes, Volumes, Timings
 8: US 64 & SR 1634 (Carolina Village Rd)

2040 Design Year - No Build
 Timing Plan: AM Peak



Lane Group	EBL	EBT	EBR	WBL	WBT	WBR	NBL	NBT	NBR	SBL	SBT	SBR
Approach LOS		F				F				F		
Queue Length 50th (ft)	77	~1084			~318	~1271	97		~355		~312	73
Queue Length 95th (ft)	#177	#1220			m#438	#1403	m147		#552		#498	121
Internal Link Dist (ft)		480				648			139		279	
Turn Bay Length (ft)	100			100								150
Base Capacity (vph)	94	1700			227	2012	900		272		231	594
Starvation Cap Reductn	0	0			0	155	0		0		0	0
Spillback Cap Reductn	0	0			0	0	0		0		0	0
Storage Cap Reductn	0	0			0	0	0		0		0	0
Reduced v/c Ratio	0.83	1.10			1.19	1.19	0.26		1.14		1.16	0.19

Intersection Summary

Area Type: Other
 Cycle Length: 150
 Actuated Cycle Length: 150
 Offset: 147 (98%), Referenced to phase 2:EBT and 6:WBT, Start of Green
 Natural Cycle: 160
 Control Type: Actuated-Coordinated
 Maximum v/c Ratio: 1.19
 Intersection Signal Delay: 107.6 Intersection LOS: F
 Intersection Capacity Utilization 107.3% ICU Level of Service G
 Analysis Period (min) 15
 ~ Volume exceeds capacity, queue is theoretically infinite.
 Queue shown is maximum after two cycles.
 # 95th percentile volume exceeds capacity, queue may be longer.
 Queue shown is maximum after two cycles.
 m Volume for 95th percentile queue is metered by upstream signal.

Splits and Phases: 8: US 64 & SR 1634 (Carolina Village Rd)



Lanes, Volumes, Timings
 9: SR 1783 (Upward Rd) & I-26 NB On-Ramp

2040 Design Year - No Build
 Timing Plan: AM Peak



Lane Group	EBL	EBT	EBR	WBL	WBT	WBR	NBL	NBT	NBR	SBL	SBT	SBR
Lane Configurations	↗↘	↗↗			↖↗		↖	↖	↖			
Volume (vph)	446	578	0	0	821	134	612	0	188	0	0	0
Ideal Flow (vphpl)	1900	1900	1900	1900	1900	1900	1900	1900	1900	1900	1900	1900
Grade (%)		-3%			3%			4%			0%	
Storage Length (ft)	275		0	0		0	250		175	0		0
Storage Lanes	1		0	0		0	1		1	0		0
Taper Length (ft)	100		100	100		100	100		100	100		100
Lane Util. Factor	0.97	0.95	1.00	1.00	0.95	0.95	0.95	0.95	1.00	1.00	1.00	1.00
Frt					0.979				0.850			
Flt Protected	0.950						0.950	0.950				
Satd. Flow (prot)	3291	3592	0	0	3385	0	1648	1648	1552	0	0	0
Flt Permitted	0.950						0.950	0.950				
Satd. Flow (perm)	3291	3592	0	0	3385	0	1648	1648	1552	0	0	0
Right Turn on Red			No			No			No			No
Satd. Flow (RTOR)												
Link Speed (mph)		45			45			35			45	
Link Distance (ft)		630			322			532			658	
Travel Time (s)		9.5			4.9			10.4			10.0	
Peak Hour Factor	0.90	0.90	0.90	0.90	0.90	0.90	0.90	0.90	0.90	0.90	0.90	0.90
Heavy Vehicles (%)	8%	2%	5%	5%	2%	8%	2%	2%	2%	5%	5%	5%
Adj. Flow (vph)	496	642	0	0	912	149	680	0	209	0	0	0
Shared Lane Traffic (%)							50%					
Lane Group Flow (vph)	496	642	0	0	1061	0	340	340	209	0	0	0
Turn Type	Prot						Split		Prot			
Protected Phases	5	2			6		8	8	8			
Permitted Phases												
Detector Phase	5	2			6		8	8	8			
Switch Phase												
Minimum Initial (s)	7.0	14.0			14.0		7.0	7.0	7.0			
Minimum Split (s)	14.0	22.0			21.0		19.0	19.0	19.0			
Total Split (s)	21.0	61.0	0.0	0.0	40.0	0.0	29.0	29.0	29.0	0.0	0.0	0.0
Total Split (%)	23.3%	67.8%	0.0%	0.0%	44.4%	0.0%	32.2%	32.2%	32.2%	0.0%	0.0%	0.0%
Maximum Green (s)	14.7	54.8			34.4		22.9	22.9	22.9			
Yellow Time (s)	3.0	5.1			4.6		3.6	3.6	3.6			
All-Red Time (s)	3.3	1.1			1.0		2.5	2.5	2.5			
Lost Time Adjust (s)	-1.3	-1.2	0.0	0.0	-0.6	-2.0	-1.1	-1.1	-1.1	-2.0	0.0	0.0
Total Lost Time (s)	5.0	5.0	4.0	4.0	5.0	2.0	5.0	5.0	5.0	2.0	4.0	4.0
Lead/Lag	Lag				Lead							
Lead-Lag Optimize?	Yes				Yes							
Vehicle Extension (s)	2.0	2.0			2.0		2.0	2.0	2.0			
Minimum Gap (s)	3.0	3.1			3.1		3.0	3.0	3.0			
Time Before Reduce (s)	0.0	15.0			15.0		0.0	0.0	0.0			
Time To Reduce (s)	0.0	45.0			45.0		0.0	0.0	0.0			
Recall Mode	None	C-Max			C-Max		None	None	None			
Act Effct Green (s)	16.0	57.9			36.9		22.1	22.1	22.1			
Actuated g/C Ratio	0.18	0.64			0.41		0.25	0.25	0.25			
v/c Ratio	0.85	0.28			0.76		0.84	0.84	0.55			
Control Delay	51.5	3.3			27.9		51.3	51.3	35.0			
Queue Delay	0.0	0.0			0.0		0.0	0.0	0.0			

Lanes, Volumes, Timings
 9: SR 1783 (Upward Rd) & I-26 NB On-Ramp

2040 Design Year - No Build
 Timing Plan: AM Peak



Lane Group	EBL	EBT	EBR	WBL	WBT	WBR	NBL	NBT	NBR	SBL	SBT	SBR
Total Delay	51.5	3.3			27.9		51.3	51.3	35.0			
LOS	D	A			C		D	D	D			
Approach Delay		24.3			27.9			47.5				
Approach LOS		C			C			D				
Queue Length 50th (ft)	159	27			276		188	188	101			
Queue Length 95th (ft)	#233	34			360		#326	#326	170			
Internal Link Dist (ft)		550			242			452			578	
Turn Bay Length (ft)	275						250		175			
Base Capacity (vph)	585	2310			1387		439	439	414			
Starvation Cap Reductn	0	0			0		0	0	0			
Spillback Cap Reductn	0	0			0		0	0	0			
Storage Cap Reductn	0	0			0		0	0	0			
Reduced v/c Ratio	0.85	0.28			0.76		0.77	0.77	0.50			

Intersection Summary

Area Type: Other
 Cycle Length: 90
 Actuated Cycle Length: 90
 Offset: 7 (8%), Referenced to phase 2:EBT and 6:WBT, Start of Green
 Natural Cycle: 60
 Control Type: Actuated-Coordinated
 Maximum v/c Ratio: 0.85
 Intersection Signal Delay: 32.2
 Intersection LOS: C
 Intersection Capacity Utilization 69.4%
 ICU Level of Service C
 Analysis Period (min) 15
 # 95th percentile volume exceeds capacity, queue may be longer.
 Queue shown is maximum after two cycles.

Splits and Phases: 9: SR 1783 (Upward Rd) & I-26 NB On-Ramp

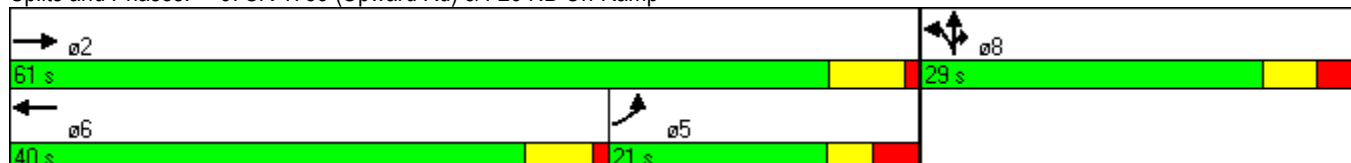

Lanes, Volumes, Timings
 10: SR 1783 (Upward Rd) & I-26 SB Off-Ramp

2040 Design Year - No Build

Timing Plan: AM Peak



Lane Group	EBL	EBT	EBR	WBL	WBT	WBR	NBL	NBT	NBR	SBL	SBT	SBR
Lane Configurations		↑↑↑	↗	↖	↑↑						↖	↗↗
Volume (vph)	0	892	589	237	1196	0	0	0	0	132	0	579
Ideal Flow (vphpl)	1900	1900	1900	1900	1900	1900	1900	1900	1900	1900	1900	1900
Grade (%)		4%			-4%			0%			5%	
Storage Length (ft)	275		0	150		0	0		0	250		0
Storage Lanes	1		1	1		0	0		0	1		2
Taper Length (ft)	100		100	100		100	100		100	100		100
Lane Util. Factor	1.00	0.91	1.00	1.00	0.95	1.00	1.00	1.00	1.00	1.00	1.00	0.88
Frt		0.850										0.850
Flt Protected				0.950							0.950	
Satd. Flow (prot)	0	4841	1507	1753	3507	0	0	0	0	0	1676	2639
Flt Permitted				0.237							0.950	
Satd. Flow (perm)	0	4841	1507	437	3507	0	0	0	0	0	1676	2639
Right Turn on Red			No			No			No			No
Satd. Flow (RTOR)												
Link Speed (mph)		45			45			45			35	
Link Distance (ft)		549			630			547			651	
Travel Time (s)		8.3			9.5			8.3			12.7	
Peak Hour Factor	0.90	0.90	0.90	0.90	0.90	0.90	0.90	0.90	0.90	0.90	0.90	0.90
Adj. Flow (vph)	0	991	654	263	1329	0	0	0	0	147	0	643
Shared Lane Traffic (%)												
Lane Group Flow (vph)	0	991	654	263	1329	0	0	0	0	0	147	643
Turn Type			Perm		pm+pt					Split		Prot
Protected Phases		2		1	6					4	4	4
Permitted Phases			2	6								
Detector Phase		2	2	1	6					4	4	4
Switch Phase												
Minimum Initial (s)		14.0	14.0	7.0	14.0					7.0	7.0	7.0
Minimum Split (s)		20.0	20.0	14.0	21.0					13.0	13.0	13.0
Total Split (s)	0.0	48.0	48.0	14.0	62.0	0.0	0.0	0.0	0.0	28.0	28.0	28.0
Total Split (%)	0.0%	53.3%	53.3%	15.6%	68.9%	0.0%	0.0%	0.0%	0.0%	31.1%	31.1%	31.1%
Maximum Green (s)		42.4	42.4	7.6	55.6					22.1	22.1	22.1
Yellow Time (s)		4.5	4.5	3.0	5.2					3.6	3.6	3.6
All-Red Time (s)		1.1	1.1	3.4	1.2					2.3	2.3	2.3
Lost Time Adjust (s)	-2.0	-0.6	-0.6	-1.4	-1.4	-2.0	0.0	0.0	0.0	-2.0	-0.9	-0.9
Total Lost Time (s)	2.0	5.0	5.0	5.0	5.0	2.0	4.0	4.0	4.0	3.9	5.0	5.0
Lead/Lag		Lead	Lead	Lag								
Lead-Lag Optimize?		Yes	Yes	Yes								
Vehicle Extension (s)		2.0	2.0	2.0	2.0					2.0	2.0	2.0
Minimum Gap (s)		3.1	3.1	3.0	3.1					3.0	3.0	3.0
Time Before Reduce (s)		15.0	15.0	0.0	15.0					0.0	0.0	0.0
Time To Reduce (s)		45.0	45.0	0.0	45.0					0.0	0.0	0.0
Recall Mode		C-Max	C-Max	None	C-Max					None	None	None
Act Effct Green (s)		43.0	43.0	57.0	57.0						23.0	23.0
Actuated g/C Ratio		0.48	0.48	0.63	0.63						0.26	0.26
v/c Ratio		0.43	0.91	0.64	0.60						0.34	0.95
Control Delay		16.2	40.8	14.8	4.4						30.1	59.5
Queue Delay		0.0	0.0	0.0	0.0						0.0	0.0
Total Delay		16.2	40.8	14.8	4.4						30.1	59.5

Lanes, Volumes, Timings
 10: SR 1783 (Upward Rd) & I-26 SB Off-Ramp

2040 Design Year - No Build
 Timing Plan: AM Peak



Lane Group	EBL	EBT	EBR	WBL	WBT	WBR	NBL	NBT	NBR	SBL	SBT	SBR
LOS		B	D	B	A						C	E
Approach Delay		26.0			6.1						54.0	
Approach LOS		C			A						D	
Queue Length 50th (ft)		130	330	43	174						68	204
Queue Length 95th (ft)		164	#559	m49	138						122	#325
Internal Link Dist (ft)		469			550			467			571	
Turn Bay Length (ft)				150								
Base Capacity (vph)		2313	720	408	2221						428	674
Starvation Cap Reductn		0	0	0	0						0	0
Spillback Cap Reductn		0	0	0	0						0	0
Storage Cap Reductn		0	0	0	0						0	0
Reduced v/c Ratio		0.43	0.91	0.64	0.60						0.34	0.95

Intersection Summary

Area Type: Other
 Cycle Length: 90
 Actuated Cycle Length: 90
 Offset: 88 (98%), Referenced to phase 2:EBT and 6:WBTL, Start of Green
 Natural Cycle: 90
 Control Type: Actuated-Coordinated
 Maximum v/c Ratio: 0.95
 Intersection Signal Delay: 23.6
 Intersection LOS: C
 Intersection Capacity Utilization 69.4%
 ICU Level of Service C
 Analysis Period (min) 15
 # 95th percentile volume exceeds capacity, queue may be longer.
 Queue shown is maximum after two cycles.
 m Volume for 95th percentile queue is metered by upstream signal.

Splits and Phases: 10: SR 1783 (Upward Rd) & I-26 SB Off-Ramp

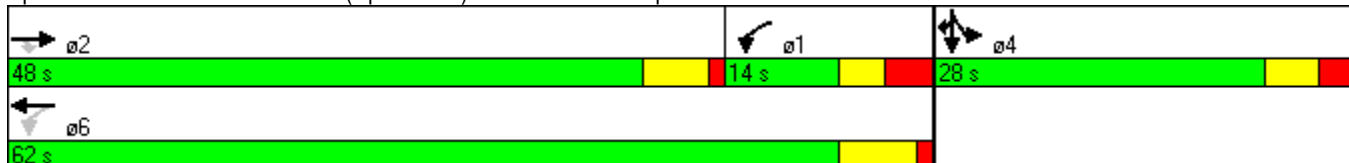

Lanes, Volumes, Timings
 1: NC 146 (Long Shoals Rd) & I-26 NB On-Ramp

2040 Design Year - No-Build

Timing Plan: PM Peak

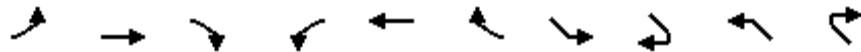

Lane Group	EBL	EBT	EBR2	WBL	WBT	WBR2	SEL	SER2	NWL	NWR2
Lane Configurations										
Volume (vph)	392	1162	310	379	884	815	842	308	307	494
Ideal Flow (vphpl)	1900	1900	1900	1900	1900	1900	1900	1900	1900	1900
Grade (%)		3%			-7%					
Storage Length (ft)	450			350			0		675	
Storage Lanes	1			2			2		1	
Taper Length (ft)	100			100			100		100	
Lane Util. Factor	0.97	0.95	1.00	0.97	0.95	1.00	0.97	1.00	0.97	1.00
Frt			0.850			0.850		0.850		0.850
Flt Protected	0.950			0.950			0.950		0.950	
Satd. Flow (prot)	3224	3452	1487	3387	3663	1562	3519	1607	3434	1599
Flt Permitted	0.950			0.950			0.950		0.950	
Satd. Flow (perm)	3224	3452	1487	3387	3663	1562	3519	1607	3434	1599
Right Turn on Red			No			No		No		No
Satd. Flow (RTOR)										
Link Speed (mph)		45			45					
Link Distance (ft)		1009			964					
Travel Time (s)		15.3			14.6					
Peak Hour Factor	0.90	0.90	0.90	0.90	0.90	0.90	0.90	0.90	0.90	0.90
Heavy Vehicles (%)	7%	3%	7%	7%	2%	7%	2%	3%	3%	2%
Adj. Flow (vph)	436	1291	344	421	982	906	936	342	341	549
Shared Lane Traffic (%)										
Lane Group Flow (vph)	436	1291	344	421	982	906	936	342	341	549
Turn Type	Prot		Free	Prot		Free	Prot	custom	Prot	Free
Protected Phases	5	2		1	6		4		8	
Permitted Phases			Free			Free		4		Free
Detector Phase	5	2		1	6		4	4	8	
Switch Phase										
Minimum Initial (s)	7.0	12.0		7.0	12.0		7.0	7.0	7.0	
Minimum Split (s)	16.0	20.0		15.0	21.0		16.0	16.0	15.0	
Total Split (s)	24.0	47.0	0.0	19.0	42.0	0.0	34.0	34.0	34.0	0.0
Total Split (%)	24.0%	47.0%	0.0%	19.0%	42.0%	0.0%	34.0%	34.0%	34.0%	0.0%
Maximum Green (s)	15.8	39.5		11.3	33.0		25.9	25.9	26.0	
Yellow Time (s)	3.4	4.3		4.0	5.2		3.8	3.8	3.7	
All-Red Time (s)	4.8	3.2		3.7	3.8		4.3	4.3	4.3	
Lost Time Adjust (s)	-3.2	-2.5	-2.5	-2.7	-4.0	-4.0	-3.1	-3.1	-3.0	0.0
Total Lost Time (s)	5.0	5.0	1.5	5.0	5.0	0.0	5.0	5.0	5.0	4.0
Lead/Lag	Lead	Lag		Lead	Lag					
Lead-Lag Optimize?	Yes	Yes		Yes	Yes					
Vehicle Extension (s)	2.0	6.0		2.0	6.0		2.0	2.0	2.0	
Minimum Gap (s)	3.0	3.0		3.0	3.0		3.0	3.0	3.0	
Time Before Reduce (s)	0.0	15.0		0.0	15.0		0.0	0.0	0.0	
Time To Reduce (s)	0.0	30.0		0.0	30.0		0.0	0.0	0.0	
Recall Mode	None	C-Max		None	C-Max		None	None	None	
Act Effct Green (s)	18.4	42.0	100.0	14.1	37.7	100.0	28.9	28.9	28.9	100.0
Actuated g/C Ratio	0.18	0.42	1.00	0.14	0.38	1.00	0.29	0.29	0.29	1.00
v/c Ratio	0.74	0.89	0.23	0.88	0.71	0.58	0.92	0.74	0.34	0.34
Control Delay	46.6	36.1	0.4	63.6	30.2	1.6	49.6	43.0	29.2	0.6
Queue Delay	0.0	0.0	0.0	0.0	0.0	0.0	0.0	0.0	0.0	0.0

Lanes, Volumes, Timings
 1: NC 146 (Long Shoals Rd) & I-26 NB On-Ramp

2040 Design Year - No-Build
 Timing Plan: PM Peak

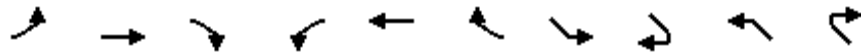

Lane Group	EBL	EBT	EBR2	WBL	WBT	WBR2	SEL	SER2	NWL	NWR2
Total Delay	46.6	36.1	0.4	63.6	30.2	1.6	49.6	43.0	29.2	0.6
LOS	D	D	A	E	C	A	D	D	C	A
Approach Delay	32.4			25.1						
Approach LOS	C			C						
Queue Length 50th (ft)	135	392	0	137	279	0	296	196	88	0
Queue Length 95th (ft)	189	#531	0	#223	354	0	#414	#309	126	0
Internal Link Dist (ft)	929			884						
Turn Bay Length (ft)	450		300	350		300		425	675	575
Base Capacity (vph)	613	1450	1487	477	1381	1562	1021	466	996	1599
Starvation Cap Reductn	0	0	0	0	0	0	0	0	0	0
Spillback Cap Reductn	0	0	0	0	0	0	0	0	0	0
Storage Cap Reductn	0	0	0	0	0	0	0	0	0	0
Reduced v/c Ratio	0.71	0.89	0.23	0.88	0.71	0.58	0.92	0.73	0.34	0.34

Intersection Summary

Area Type: Other
 Cycle Length: 100
 Actuated Cycle Length: 100
 Offset: 0 (0%), Referenced to phase 2:EBT and 6:WBT, Start of Green
 Natural Cycle: 80
 Control Type: Actuated-Coordinated
 Maximum v/c Ratio: 0.92
 Intersection Signal Delay: 30.0
 Intersection LOS: C
 Intersection Capacity Utilization 79.5%
 ICU Level of Service D
 Analysis Period (min) 15
 # 95th percentile volume exceeds capacity, queue may be longer.
 Queue shown is maximum after two cycles.

Splits and Phases: 1: NC 146 (Long Shoals Rd) & I-26 NB On-Ramp

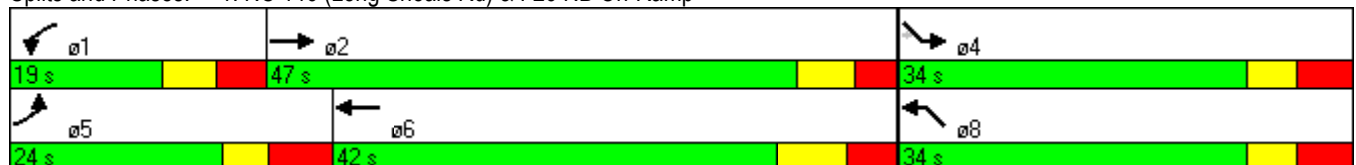

Lanes, Volumes, Timings
2: I-26 NB On-Ramp & US 25 (Asheville Highway)

2040 Design Year - No-Build
Timing Plan: PM Peak



Lane Group	EBL	EBT	EBR	WBL	WBT	WBR	NBL	NBT	NBR	SBL	SBT	SBR
Lane Configurations				↙		↗	↗	↗	↗		↗	↗
Volume (vph)	0	0	0	285	0	509	997	1514	0	0	1433	219
Ideal Flow (vphpl)	1900	1900	1900	1900	1900	1900	1900	1900	1900	1900	1900	1900
Grade (%)		0%			2%			-1%			2%	
Storage Length (ft)	0		0	0		150	0		0	0		300
Storage Lanes	0		0	1		2	1		0	0		1
Taper Length (ft)	100		100	100		100	100		100	100		100
Lane Util. Factor	1.00	1.00	1.00	1.00	1.00	0.88	1.00	0.95	1.00	1.00	0.95	1.00
Frt						0.850						0.850
Flt Protected				0.950			0.950					
Satd. Flow (prot)	0	0	0	1735	0	2706	1680	3489	0	0	3436	1480
Flt Permitted				0.950			0.950					
Satd. Flow (perm)	0	0	0	1735	0	2706	1680	3489	0	0	3436	1480
Right Turn on Red			No			No			No			No
Satd. Flow (RTOR)												
Link Speed (mph)		45			35			45			45	
Link Distance (ft)		533			612			601			596	
Travel Time (s)		8.1			11.9			9.1			9.0	
Peak Hour Factor	0.90	0.90	0.90	0.90	0.90	0.90	0.90	0.90	0.90	0.90	0.90	0.90
Heavy Vehicles (%)	5%	5%	5%	3%	5%	4%	8%	4%	5%	5%	4%	8%
Adj. Flow (vph)	0	0	0	317	0	566	1108	1682	0	0	1592	243
Shared Lane Traffic (%)												
Lane Group Flow (vph)	0	0	0	317	0	566	1108	1682	0	0	1592	243
Turn Type				Prot		custom	Prot					Free
Protected Phases				4			5	2			6	
Permitted Phases						4						Free
Detector Phase				4		4	5	2			6	
Switch Phase												
Minimum Initial (s)				7.0		7.0	7.0	12.0			12.0	
Minimum Split (s)				13.0		13.0	14.0	19.0			18.0	
Total Split (s)	0.0	0.0	0.0	20.0	0.0	20.0	50.0	90.0	0.0	0.0	40.0	0.0
Total Split (%)	0.0%	0.0%	0.0%	18.2%	0.0%	18.2%	45.5%	81.8%	0.0%	0.0%	36.4%	0.0%
Maximum Green (s)				14.0		14.0	43.6	83.9			34.7	
Yellow Time (s)				3.7		3.7	3.0	4.6			4.3	
All-Red Time (s)				2.3		2.3	3.4	1.5			1.0	
Lost Time Adjust (s)	0.0	0.0	-2.0	-2.0	0.0	-2.0	-1.4	-1.1	0.0	-2.0	-0.3	0.0
Total Lost Time (s)	4.0	4.0	2.0	4.0	4.0	4.0	5.0	5.0	4.0	2.0	5.0	4.0
Lead/Lag							Lag				Lead	
Lead-Lag Optimize?							Yes				Yes	
Vehicle Extension (s)				2.0		2.0	2.0	8.0			8.0	
Minimum Gap (s)				3.0		3.0	3.0	5.5			5.5	
Time Before Reduce (s)				0.0		0.0	0.0	15.0			15.0	
Time To Reduce (s)				0.0		0.0	0.0	50.0			50.0	
Recall Mode				None		None	None	C-Max			C-Max	
Act Effct Green (s)				16.0		16.0	45.0	85.0			35.0	110.0
Actuated g/C Ratio				0.15		0.15	0.41	0.77			0.32	1.00
v/c Ratio				1.26		1.44	1.61	0.62			1.46	0.16
Control Delay				183.8		246.0	299.5	9.9			241.1	0.2
Queue Delay				0.0		0.0	5.3	1.2			14.7	0.0

Lanes, Volumes, Timings
 2: I-26 NB On-Ramp & US 25 (Asheville Highway)

2040 Design Year - No-Build

Timing Plan: PM Peak



Lane Group	EBL	EBT	EBR	WBL	WBT	WBR	NBL	NBT	NBR	SBL	SBT	SBR
Total Delay				183.8		246.0	304.8	11.1			255.8	0.2
LOS				F		F	F	B			F	A
Approach Delay								127.7			222.0	
Approach LOS								F			F	
Queue Length 50th (ft)				~281		~309	~1104	209			~810	0
Queue Length 95th (ft)				#458		#430	m#279	m131			#948	0
Internal Link Dist (ft)		453			532			521			516	
Turn Bay Length (ft)						150						300
Base Capacity (vph)				252		394	687	2696			1093	1480
Starvation Cap Reductn				0		0	5	720			0	0
Spillback Cap Reductn				0		0	0	0			24	0
Storage Cap Reductn				0		0	0	0			0	0
Reduced v/c Ratio				1.26		1.44	1.62	0.85			1.49	0.16

Intersection Summary

Area Type: Other
 Cycle Length: 110
 Actuated Cycle Length: 110
 Offset: 66 (60%), Referenced to phase 2:NBT and 6:SBT, Start of Green
 Natural Cycle: 200
 Control Type: Actuated-Coordinated
 Maximum v/c Ratio: 1.61
 Intersection Signal Delay: 174.5
 Intersection Capacity Utilization 122.3%
 Analysis Period (min) 15
 Intersection LOS: F
 ICU Level of Service H

~ Volume exceeds capacity, queue is theoretically infinite.
 Queue shown is maximum after two cycles.

95th percentile volume exceeds capacity, queue may be longer.
 Queue shown is maximum after two cycles.

m Volume for 95th percentile queue is metered by upstream signal.

Splits and Phases: 2: I-26 NB On-Ramp & US 25 (Asheville Highway)

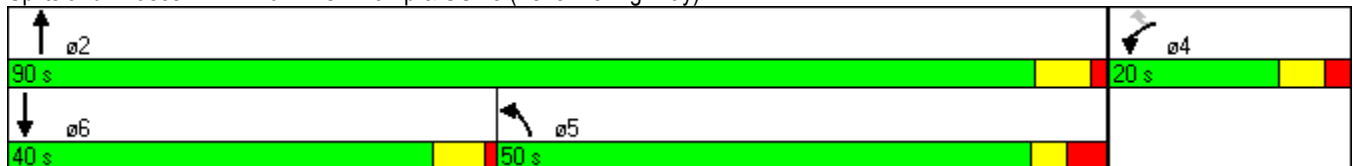

Lanes, Volumes, Timings
 3: I-26 SB Off-Ramp & US 25 (Asheville Highway)

2040 Design Year - No-Build
 Timing Plan: PM Peak



Lane Group	EBL	EBT	EBR	WBL	WBT	WBR	NBL	NBT	NBR	SBL	SBT	SBR
Lane Configurations												
Volume (vph)	221	0	801	0	0	0	0	2290	287	406	1312	0
Ideal Flow (vphpl)	1900	1900	1900	1900	1900	1900	1900	1900	1900	1900	1900	1900
Grade (%)		3%			0%			4%			1%	
Storage Length (ft)	0		100	0		0	0		500	0		0
Storage Lanes	1		1	0		0	0		1	1		0
Taper Length (ft)	100		100	100		100	100		100	100		100
Lane Util. Factor	1.00	1.00	1.00	1.00	1.00	1.00	1.00	0.95	1.00	1.00	0.95	1.00
Frt			0.850						0.850			
Flt Protected	0.950									0.950		
Satd. Flow (prot)	1710	0	1544	0	0	0	0	3435	1465	1663	3487	0
Flt Permitted	0.950									0.950		
Satd. Flow (perm)	1710	0	1544	0	0	0	0	3435	1465	1663	3487	0
Right Turn on Red			Yes			No			No			No
Satd. Flow (RTOR)			53									
Link Speed (mph)		35			45			45			45	
Link Distance (ft)		471			598			795			601	
Travel Time (s)		9.2			9.1			12.0			9.1	
Peak Hour Factor	0.90	0.90	0.90	0.90	0.90	0.90	0.90	0.90	0.90	0.90	0.90	0.90
Heavy Vehicles (%)	4%	5%	3%	5%	5%	5%	5%	3%	8%	8%	3%	5%
Adj. Flow (vph)	246	0	890	0	0	0	0	2544	319	451	1458	0
Shared Lane Traffic (%)												
Lane Group Flow (vph)	246	0	890	0	0	0	0	2544	319	451	1458	0
Turn Type	Prot		custom						Free	Prot		
Protected Phases	4		4					2		1	6	
Permitted Phases									Free			
Detector Phase	4		4					2		1	6	
Switch Phase												
Minimum Initial (s)	7.0		7.0					12.0		7.0	12.0	
Minimum Split (s)	14.0		14.0					19.0		14.0	19.0	
Total Split (s)	35.0	0.0	35.0	0.0	0.0	0.0	0.0	53.0	0.0	22.0	75.0	0.0
Total Split (%)	31.8%	0.0%	31.8%	0.0%	0.0%	0.0%	0.0%	48.2%	0.0%	20.0%	68.2%	0.0%
Maximum Green (s)	29.0		29.0					47.3		15.5	69.3	
Yellow Time (s)	4.0		4.0					4.7		4.0	4.7	
All-Red Time (s)	2.0		2.0					1.0		2.5	1.0	
Lost Time Adjust (s)	-1.0	-2.0	-1.0	-2.0	-2.0	-2.0	-2.0	-0.7	-0.7	-1.5	-1.7	-2.0
Total Lost Time (s)	5.0	2.0	5.0	2.0	2.0	2.0	2.0	5.0	3.3	5.0	4.0	2.0
Lead/Lag								Lead		Lag		
Lead-Lag Optimize?								Yes		Yes		
Vehicle Extension (s)	2.0		2.0					8.0		2.0	8.0	
Minimum Gap (s)	3.0		3.0					5.5		3.0	5.5	
Time Before Reduce (s)	0.0		0.0					15.0		0.0	15.0	
Time To Reduce (s)	0.0		0.0					50.0		0.0	50.0	
Recall Mode	None		None					C-Max		None	C-Max	
Act Effct Green (s)	30.0		30.0					48.0	110.0	17.0	71.0	
Actuated g/C Ratio	0.27		0.27					0.44	1.00	0.15	0.65	
v/c Ratio	0.53		1.93					1.70	0.22	1.75	0.65	
Control Delay	38.9		453.0					341.9	0.3	377.5	30.9	
Queue Delay	0.6		0.0					9.8	0.0	0.0	8.1	

Lanes, Volumes, Timings
 3: I-26 SB Off-Ramp & US 25 (Asheville Highway)

2040 Design Year - No-Build
 Timing Plan: PM Peak

Lane Group	EBL	EBT	EBR	WBL	WBT	WBR	NBL	NBT	NBR	SBL	SBT	SBR
Total Delay	39.5		453.0					351.7	0.3	377.5	39.0	
LOS	D		F					F	A	F	D	
Approach Delay								312.5			119.0	
Approach LOS								F			F	
Queue Length 50th (ft)	148		~955					~1391	0	~478	488	
Queue Length 95th (ft)	230		#1201					#1525	0	m#279	m344	
Internal Link Dist (ft)		391			518			715				521
Turn Bay Length (ft)			100						500			
Base Capacity (vph)	466		460					1499	1465	257	2251	
Starvation Cap Reductn	0		0					0	0	0	759	
Spillback Cap Reductn	51		0					19	0	0	0	
Storage Cap Reductn	0		0					0	0	0	0	
Reduced v/c Ratio	0.59		1.93					1.72	0.22	1.75	0.98	

Intersection Summary

Area Type: Other
 Cycle Length: 110
 Actuated Cycle Length: 110
 Offset: 0 (0%), Referenced to phase 2:NBT and 6:SBT, Start of Green
 Natural Cycle: 220
 Control Type: Actuated-Coordinated
 Maximum v/c Ratio: 1.93
 Intersection Signal Delay: 259.8
 Intersection LOS: F
 Intersection Capacity Utilization 122.3%
 ICU Level of Service H
 Analysis Period (min) 15
 ~ Volume exceeds capacity, queue is theoretically infinite.
 Queue shown is maximum after two cycles.
 # 95th percentile volume exceeds capacity, queue may be longer.
 Queue shown is maximum after two cycles.
 m Volume for 95th percentile queue is metered by upstream signal.

Splits and Phases: 3: I-26 SB Off-Ramp & US 25 (Asheville Highway)

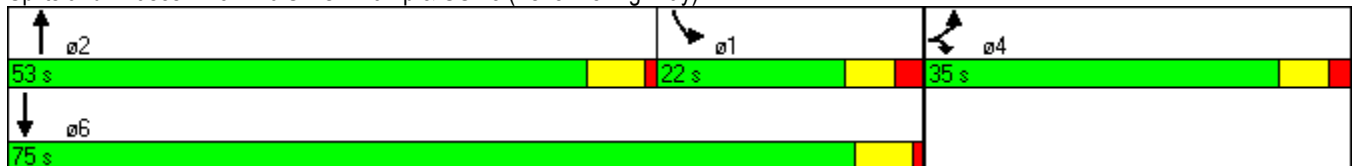

Lanes, Volumes, Timings
4: I-26 NB Ramps & Balfour Pkwy

2040 Design Year - No-Build
Timing Plan: PM Peak



Lane Group	EBL	EBT	EBR	WBL	WBT	WBR	NBL	NBT	NBR	SBL	SBT	SBR
Lane Configurations			↗↗			↗	↗	↗↗			↗↗	↗
Volume (vph)	0	0	641	0	0	346	304	1690	0	0	937	735
Ideal Flow (vphpl)	1900	1900	1900	1900	1900	1900	1900	1900	1900	1900	1900	1900
Storage Length (ft)	0		0	0		0	250		0	0		250
Storage Lanes	0		2	0		1	1		0	0		1
Taper Length (ft)	100		100	100		100	100		100	100		100
Lane Util. Factor	1.00	1.00	0.88	1.00	1.00	1.00	1.00	0.95	1.00	1.00	0.95	1.00
Frt			0.850			0.865						0.850
Flt Protected							0.950					
Satd. Flow (prot)	0	0	2787	0	0	1611	1671	3539	0	0	3539	1495
Flt Permitted							0.950					
Satd. Flow (perm)	0	0	2787	0	0	1611	1671	3539	0	0	3539	1495
Right Turn on Red			No			No			No			No
Satd. Flow (RTOR)												
Link Speed (mph)		25			45			45				45
Link Distance (ft)		393			429			690				522
Travel Time (s)		10.7			6.5			10.5				7.9
Peak Hour Factor	0.90	0.90	0.90	0.90	0.90	0.90	0.90	0.90	0.90	0.90	0.90	0.90
Heavy Vehicles (%)	5%	5%	2%	5%	5%	2%	8%	2%	5%	5%	2%	8%
Adj. Flow (vph)	0	0	712	0	0	384	338	1878	0	0	1041	817
Shared Lane Traffic (%)												
Lane Group Flow (vph)	0	0	712	0	0	384	338	1878	0	0	1041	817
Turn Type			Over			Free	Prot					Perm
Protected Phases			5				5	Free				6
Permitted Phases						Free						6
Detector Phase			5				5					6
Switch Phase												
Minimum Initial (s)			7.0				7.0				12.0	12.0
Minimum Split (s)			14.0				14.0				19.0	19.0
Total Split (s)	0.0	0.0	30.0	0.0	0.0	0.0	30.0	0.0	0.0	0.0	60.0	60.0
Total Split (%)	0.0%	0.0%	33.3%	0.0%	0.0%	0.0%	33.3%	0.0%	0.0%	0.0%	66.7%	66.7%
Maximum Green (s)			23.0				23.0				53.0	53.0
Yellow Time (s)			5.0				5.0				5.0	5.0
All-Red Time (s)			2.0				2.0				2.0	2.0
Lost Time Adjust (s)	-2.0	-2.0	-2.0	-2.0	-2.0	-2.0	-2.0	-2.0	-2.0	-2.0	-2.0	-2.0
Total Lost Time (s)	2.0	2.0	5.0	2.0	2.0	2.0	5.0	2.0	2.0	2.0	5.0	5.0
Lead/Lag			Lead				Lead				Lag	Lag
Lead-Lag Optimize?			Yes				Yes				Yes	Yes
Vehicle Extension (s)			3.0				3.0				3.0	3.0
Recall Mode			None				None				C-Max	C-Max
Act Effct Green (s)			25.0			90.0	25.0	90.0			55.0	55.0
Actuated g/C Ratio			0.28			1.00	0.28	1.00			0.61	0.61
v/c Ratio			0.92			0.24	0.73	0.53			0.48	0.89
Control Delay			50.7			0.3	31.7	0.3			10.6	29.7
Queue Delay			0.0			0.0	0.0	0.0			0.0	0.0
Total Delay			50.7			0.3	31.7	0.3			10.6	29.7
LOS			D			A	C	A			B	C
Approach Delay								5.1			19.0	
Approach LOS								A			B	

Lanes, Volumes, Timings
4: I-26 NB Ramps & Balfour Pkwy

2040 Design Year - No-Build
Timing Plan: PM Peak



Lane Group	EBL	EBT	EBR	WBL	WBT	WBR	NBL	NBT	NBR	SBL	SBT	SBR
Queue Length 50th (ft)			222			0	175	0			156	363
Queue Length 95th (ft)			#342			0	m228	m0			202	#653
Internal Link Dist (ft)		313			349			610			442	
Turn Bay Length (ft)							250					250
Base Capacity (vph)			774			1611	464	3539			2164	914
Starvation Cap Reductn			0			0	0	0			0	0
Spillback Cap Reductn			0			0	0	0			0	0
Storage Cap Reductn			0			0	0	0			0	0
Reduced v/c Ratio			0.92			0.24	0.73	0.53			0.48	0.89

Intersection Summary



















Area Type: Other
 Cycle Length: 90
 Actuated Cycle Length: 90
 Offset: 51 (57%), Referenced to phase 6:SBT, Start of Green
 Natural Cycle: 80
 Control Type: Actuated-Coordinated
 Maximum v/c Ratio: 0.92
 Intersection Signal Delay: 16.0 Intersection LOS: B
 Intersection Capacity Utilization 70.7% ICU Level of Service C
 Analysis Period (min) 15
 # 95th percentile volume exceeds capacity, queue may be longer.
 Queue shown is maximum after two cycles.
 m Volume for 95th percentile queue is metered by upstream signal.

Splits and Phases: 4: I-26 NB Ramps & Balfour Pkwy



Lanes, Volumes, Timings
5: I-26 SB Ramps & Balfour Pkwy

2040 Design Year - No-Build
Timing Plan: PM Peak

												
Lane Group	EBL	EBT	EBR	WBL	WBT	WBR	NBL	NBT	NBR	SBL	SBT	SBR
Lane Configurations												
Volume (vph)	0	0	228	0	0	759	0	1235	662	260	1318	0
Ideal Flow (vphpl)	1900	1900	1900	1900	1900	1900	1900	1900	1900	1900	1900	1900
Storage Length (ft)	0		0	0		0	0		250	250		0
Storage Lanes	0		1	0		2	0		1	1		0
Taper Length (ft)	100		100	100		100	100		100	100		100
Lane Util. Factor	1.00	1.00	1.00	1.00	1.00	0.88	1.00	0.95	1.00	1.00	0.95	1.00
Frt			0.865			0.850			0.850			
Flt Protected										0.950		
Satd. Flow (prot)	0	0	1611	0	0	2787	0	3539	1495	1671	3539	0
Flt Permitted										0.950		
Satd. Flow (perm)	0	0	1611	0	0	2787	0	3539	1495	1671	3539	0
Right Turn on Red			No			No			No			No
Satd. Flow (RTOR)												
Link Speed (mph)		45			25			45			45	
Link Distance (ft)		642			361			480			690	
Travel Time (s)		9.7			9.8			7.3			10.5	
Peak Hour Factor	0.90	0.90	0.90	0.90	0.90	0.90	0.90	0.90	0.90	0.90	0.90	0.90
Heavy Vehicles (%)	5%	5%	2%	5%	5%	2%	5%	2%	8%	8%	2%	5%
Adj. Flow (vph)	0	0	253	0	0	843	0	1372	736	289	1464	0
Shared Lane Traffic (%)												
Lane Group Flow (vph)	0	0	253	0	0	843	0	1372	736	289	1464	0
Turn Type			Free			Over			Perm	Prot		
Protected Phases						1		2		1	Free	
Permitted Phases			Free						2			
Detector Phase						1		2	2	1		
Switch Phase												
Minimum Initial (s)						7.0		12.0	12.0	7.0		
Minimum Split (s)						14.0		19.0	19.0	14.0		
Total Split (s)	0.0	0.0	0.0	0.0	0.0	35.0	0.0	55.0	55.0	35.0	0.0	0.0
Total Split (%)	0.0%	0.0%	0.0%	0.0%	0.0%	38.9%	0.0%	61.1%	61.1%	38.9%	0.0%	0.0%
Maximum Green (s)						28.0		48.0	48.0	28.0		
Yellow Time (s)						5.0		5.0	5.0	5.0		
All-Red Time (s)						2.0		2.0	2.0	2.0		
Lost Time Adjust (s)	-2.0	-2.0	-2.0	-2.0	-2.0	-2.0	-2.0	-2.0	-2.0	-2.0	-2.0	-2.0
Total Lost Time (s)	2.0	2.0	2.0	2.0	2.0	5.0	2.0	5.0	5.0	5.0	2.0	2.0
Lead/Lag						Lead		Lag	Lag	Lead		
Lead-Lag Optimize?						Yes		Yes	Yes	Yes		
Vehicle Extension (s)						3.0		3.0	3.0	3.0		
Recall Mode						None		C-Max	C-Max	None		
Act Effct Green (s)			90.0			29.8		50.2	50.2	29.8	90.0	
Actuated g/C Ratio			1.00			0.33		0.56	0.56	0.33	1.00	
v/c Ratio			0.16			0.91		0.70	0.88	0.52	0.41	
Control Delay			0.2			44.8		16.8	32.1	20.4	0.3	
Queue Delay			0.0			0.0		0.0	0.0	0.0	0.0	
Total Delay			0.2			44.8		16.8	32.1	20.4	0.3	
LOS			A			D		B	C	C	A	
Approach Delay								22.1			3.6	
Approach LOS								C			A	

Lanes, Volumes, Timings
 5: I-26 SB Ramps & Balfour Pkwy

2040 Design Year - No-Build

Timing Plan: PM Peak



Lane Group	EBL	EBT	EBR	WBL	WBT	WBR	NBL	NBT	NBR	SBL	SBT	SBR
Queue Length 50th (ft)			0			257		278	343	111	0	
Queue Length 95th (ft)			0			#384		355	#598	m145	m0	
Internal Link Dist (ft)		562			281			400				610
Turn Bay Length (ft)									250	250		
Base Capacity (vph)			1611			929		1974	834	557	3539	
Starvation Cap Reductn			0			0		0	0	0	0	
Spillback Cap Reductn			0			0		0	0	0	0	
Storage Cap Reductn			0			0		0	0	0	0	
Reduced v/c Ratio			0.16			0.91		0.70	0.88	0.52	0.41	

Intersection Summary

Area Type: Other
 Cycle Length: 90
 Actuated Cycle Length: 90
 Offset: 0 (0%), Referenced to phase 2:NBT, Start of Green
 Natural Cycle: 70
 Control Type: Actuated-Coordinated
 Maximum v/c Ratio: 0.91
 Intersection Signal Delay: 18.3
 Intersection LOS: B
 Intersection Capacity Utilization 69.0%
 ICU Level of Service C
 Analysis Period (min) 15
 # 95th percentile volume exceeds capacity, queue may be longer.
 Queue shown is maximum after two cycles.
 m Volume for 95th percentile queue is metered by upstream signal.

Splits and Phases: 5: I-26 SB Ramps & Balfour Pkwy



Lanes, Volumes, Timings
6: US 64 & SR 1516 (Francis Rd)

2040 Design Year - No-Build

Timing Plan: PM Peak



Lane Group	EBL	EBT	EBR	WBL	WBT	WBR	NBL	NBT	NBR	SBL	SBT	SBR
Lane Configurations												
Volume (vph)	143	2074	419	69	1630	23	471	5	99	33	5	161
Ideal Flow (vphpl)	1900	1900	1900	1900	1900	1900	1900	1900	1900	1900	1900	1900
Grade (%)		-1%			4%			-1%			2%	
Storage Length (ft)	150		0	125		0	150		150	0		150
Storage Lanes	1		1	1		0	1		1	0		1
Taper Length (ft)	100		100	100		100	100		100	100		100
Lane Util. Factor	1.00	0.95	1.00	1.00	0.95	0.95	0.95	0.95	1.00	1.00	1.00	1.00
Frt			0.850		0.998				0.850			0.850
Flt Protected	0.950			0.950			0.950	0.953			0.959	
Satd. Flow (prot)	1778	3557	1591	1734	3461	0	1690	1695	1591	0	1769	1567
Flt Permitted	0.950			0.950			0.950	0.953			0.959	
Satd. Flow (perm)	1778	3557	1591	1734	3461	0	1690	1695	1591	0	1769	1567
Right Turn on Red			No			No			No			No
Satd. Flow (RTOR)												
Link Speed (mph)		45			45			35			35	
Link Distance (ft)		836			622			375			406	
Travel Time (s)		12.7			9.4			7.3			7.9	
Peak Hour Factor	0.90	0.90	0.90	0.90	0.90	0.90	0.90	0.90	0.90	0.90	0.90	0.90
Heavy Vehicles (%)	2%	2%	2%	2%	2%	2%	2%	2%	2%	2%	2%	2%
Adj. Flow (vph)	159	2304	466	77	1811	26	523	6	110	37	6	179
Shared Lane Traffic (%)							49%					
Lane Group Flow (vph)	159	2304	466	77	1837	0	267	262	110	0	43	179
Turn Type	Prot		Perm	Prot			Split		pm+ov	Split		pm+ov
Protected Phases	5	2		1	6		4	4	1	3	3	5
Permitted Phases			2						4			3
Detector Phase	5	2	2	1	6		4	4	1	3	3	5
Switch Phase												
Minimum Initial (s)	7.0	12.0	12.0	7.0	12.0		7.0	7.0	7.0	7.0	7.0	7.0
Minimum Split (s)	13.0	18.0	18.0	13.0	18.0		14.0	14.0	13.0	14.0	14.0	13.0
Total Split (s)	21.0	112.0	112.0	13.0	104.0	0.0	31.0	31.0	13.0	14.0	14.0	21.0
Total Split (%)	12.4%	65.9%	65.9%	7.6%	61.2%	0.0%	18.2%	18.2%	7.6%	8.2%	8.2%	12.4%
Maximum Green (s)	15.4	106.0	106.0	7.6	98.4		24.4	24.4	7.6	7.5	7.5	15.4
Yellow Time (s)	3.2	4.6	4.6	3.0	4.2		3.9	3.9	3.0	3.7	3.7	3.2
All-Red Time (s)	2.4	1.4	1.4	2.4	1.4		2.7	2.7	2.4	2.8	2.8	2.4
Lost Time Adjust (s)	-0.6	-1.0	-1.0	-0.4	-0.6	-2.0	-1.6	-1.6	-0.4	-2.0	-1.5	-0.6
Total Lost Time (s)	5.0	5.0	5.0	5.0	5.0	2.0	5.0	5.0	5.0	4.5	5.0	5.0
Lead/Lag	Lead	Lag	Lag	Lead	Lag		Lag	Lag	Lead	Lead	Lead	Lead
Lead-Lag Optimize?	Yes	Yes	Yes	Yes	Yes		Yes	Yes	Yes	Yes	Yes	Yes
Vehicle Extension (s)	1.0	2.0	2.0	1.0	2.0		1.0	1.0	1.0	1.0	1.0	1.0
Recall Mode	None	C-Max	C-Max	None	C-Max		None	None	None	None	None	None
Act Effct Green (s)	16.0	107.7	107.7	8.3	99.9		28.0	28.0	41.2		8.8	23.1
Actuated g/C Ratio	0.09	0.63	0.63	0.05	0.59		0.16	0.16	0.24		0.05	0.14
v/c Ratio	0.95	1.02	0.46	0.91	0.90		0.96	0.94	0.28		0.47	0.84
Control Delay	135.7	44.6	13.0	151.8	38.5		113.6	109.2	55.9		95.2	88.9
Queue Delay	0.0	0.0	0.0	0.0	0.0		0.0	0.0	0.0		0.0	0.0
Total Delay	135.7	44.6	13.0	151.8	38.5		113.6	109.2	55.9		95.2	88.9
LOS	F	D	B	F	D		F	F	E		F	F
Approach Delay		44.5			43.1			101.9			90.1	

Lanes, Volumes, Timings
6: US 64 & SR 1516 (Francis Rd)

2040 Design Year - No-Build
Timing Plan: PM Peak



Lane Group	EBL	EBT	EBR	WBL	WBT	WBR	NBL	NBT	NBR	SBL	SBT	SBR
Approach LOS		D				D			F			F
Queue Length 50th (ft)	185	~1432	148	87	930		~334	~316	103		47	145
Queue Length 95th (ft)	#340	#1549	227	#203	1055		#541	#527	165		95	#243
Internal Link Dist (ft)		756				542			295			326
Turn Bay Length (ft)	150			125			150		150			150
Base Capacity (vph)	167	2253	1007	85	2035		278	279	386		94	213
Starvation Cap Reductn	0	0	0	0	0		0	0	0		0	0
Spillback Cap Reductn	0	0	0	0	0		0	0	0		0	0
Storage Cap Reductn	0	0	0	0	0		0	0	0		0	0
Reduced v/c Ratio	0.95	1.02	0.46	0.91	0.90		0.96	0.94	0.28		0.46	0.84

Intersection Summary

Area Type: Other
 Cycle Length: 170
 Actuated Cycle Length: 170
 Offset: 33 (19%), Referenced to phase 2:EBT and 6:WBT, Start of Green
 Natural Cycle: 180
 Control Type: Actuated-Coordinated
 Maximum v/c Ratio: 1.02
 Intersection Signal Delay: 52.2
 Intersection LOS: D
 Intersection Capacity Utilization 95.5%
 ICU Level of Service F
 Analysis Period (min) 15
 ~ Volume exceeds capacity, queue is theoretically infinite.
 Queue shown is maximum after two cycles.
 # 95th percentile volume exceeds capacity, queue may be longer.
 Queue shown is maximum after two cycles.

Splits and Phases: 6: US 64 & SR 1516 (Francis Rd)

ø1	ø2	ø3	ø4
13 s	112 s	14 s	31 s
ø5	ø6		
21 s	104 s		

Lanes, Volumes, Timings
7: US 64 & I-26 SB Off-Ramp

2040 Design Year - No-Build

Timing Plan: PM Peak

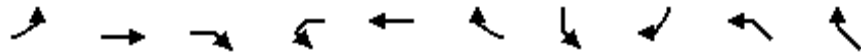

Lane Group	EBL	EBT	EBR	WBL	WBT	WBR	SBL	SBR	NWL	NWR
Lane Configurations		↑↑	↗		↑↑			↖↖		
Volume (vph)	0	2068	384	0	1647	0	0	351	0	0
Ideal Flow (vphpl)	1900	1900	1900	1900	1900	1900	1900	1900	1900	1900
Grade (%)		3%			-3%		-3%		0%	
Storage Length (ft)	0		0	0		0	0	500	0	0
Storage Lanes	0		1	0		0	0	1	0	0
Taper Length (ft)	100		100	100		100	100	100	100	100
Lane Util. Factor	1.00	0.95	1.00	1.00	0.95	1.00	1.00	0.88	1.00	1.00
Frt			0.850					0.850		
Flt Protected										
Satd. Flow (prot)	0	3486	1473	0	3592	0	0	2828	0	0
Flt Permitted										
Satd. Flow (perm)	0	3486	1473	0	3592	0	0	2828	0	0
Right Turn on Red			No			No		No		
Satd. Flow (RTOR)										
Link Speed (mph)		45			45		35		45	
Link Distance (ft)		728			745		807		350	
Travel Time (s)		11.0			11.3		15.7		5.3	
Peak Hour Factor	0.90	0.90	0.90	0.90	0.90	0.90	0.90	0.90	0.90	0.90
Heavy Vehicles (%)	5%	2%	8%	5%	2%	5%	5%	2%	5%	5%
Adj. Flow (vph)	0	2298	427	0	1830	0	0	390	0	0
Shared Lane Traffic (%)										
Lane Group Flow (vph)	0	2298	427	0	1830	0	0	390	0	0
Turn Type			Perm					custom		
Protected Phases		Free			6			4		
Permitted Phases			Free							
Detector Phase					6			4		
Switch Phase										
Minimum Initial (s)					12.0			7.0		
Minimum Split (s)					18.0			13.0		
Total Split (s)	0.0	0.0	0.0	0.0	126.0	0.0	0.0	44.0	0.0	0.0
Total Split (%)	0.0%	0.0%	0.0%	0.0%	74.1%	0.0%	0.0%	25.9%	0.0%	0.0%
Maximum Green (s)					120.2			38.9		
Yellow Time (s)					4.8			4.1		
All-Red Time (s)					1.0			1.0		
Lost Time Adjust (s)	0.0	0.0	0.0	0.0	-0.8	0.0	0.0	-0.1	-2.0	0.0
Total Lost Time (s)	4.0	4.0	4.0	4.0	5.0	4.0	4.0	5.0	2.0	4.0
Lead/Lag										
Lead-Lag Optimize?										
Vehicle Extension (s)					2.0			1.0		
Recall Mode					C-Max			None		
Act Effct Green (s)		170.0	170.0		132.9			27.1		
Actuated g/C Ratio		1.00	1.00		0.78			0.16		
v/c Ratio		0.66	0.29		0.65			0.86		
Control Delay		1.5	0.0		11.3			88.4		
Queue Delay		0.0	0.0		0.1			0.0		
Total Delay		1.5	0.0		11.4			88.4		
LOS		A	A		B			F		
Approach Delay		1.3			11.4					

Lanes, Volumes, Timings
7: US 64 & I-26 SB Off-Ramp

2040 Design Year - No-Build

Timing Plan: PM Peak

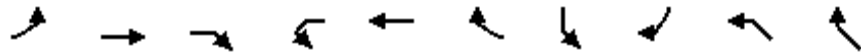

Lane Group	EBL	EBT	EBR	WBL	WBT	WBR	SBL	SBR	NWL	NWR
Approach LOS		A			B					
Queue Length 50th (ft)		0	0		422			244		
Queue Length 95th (ft)		m0	m0		m623			300		
Internal Link Dist (ft)		648			665		727		270	
Turn Bay Length (ft)								500		
Base Capacity (vph)		3486	1473		2807			649		
Starvation Cap Reductn		0	0		0			0		
Spillback Cap Reductn		0	0		149			0		
Storage Cap Reductn		0	0		0			0		
Reduced v/c Ratio		0.66	0.29		0.69			0.60		

Intersection Summary

Area Type: Other
 Cycle Length: 170
 Actuated Cycle Length: 170
 Offset: 0 (0%), Referenced to phase 6:WBT, Start of Green, Master Intersection
 Natural Cycle: 60
 Control Type: Actuated-Coordinated
 Maximum v/c Ratio: 0.86
 Intersection Signal Delay: 11.9
 Intersection LOS: B
 Intersection Capacity Utilization 95.4%
 ICU Level of Service F
 Analysis Period (min) 15
 m Volume for 95th percentile queue is metered by upstream signal.

Splits and Phases: 7: US 64 & I-26 SB Off-Ramp



Lanes, Volumes, Timings
8: US 64 & SR 1634 (Carolina Village Rd)

2040 Design Year - No-Build
Timing Plan: PM Peak



Lane Group	EBL	EBT	EBR	WBL	WBT	WBR	NBL	NBT	NBR	SBL	SBT	SBR
Lane Configurations												
Volume (vph)	100	1982	81	184	1593	237	86	5	243	208	5	70
Ideal Flow (vphpl)	1900	1900	1900	1900	1900	1900	1900	1900	1900	1900	1900	1900
Grade (%)		1%			-3%			3%			-1%	
Storage Length (ft)	100		0	100		0	0		0	0		150
Storage Lanes	1		0	1		1	0		0	0		1
Taper Length (ft)	100		100	100		100	100		100	100		100
Lane Util. Factor	1.00	0.95	0.95	1.00	0.95	1.00	1.00	1.00	1.00	1.00	1.00	1.00
Frt		0.994				0.850		0.902				0.850
Flt Protected	0.950			0.950				0.987			0.954	
Satd. Flow (prot)	1761	3500	0	1796	3592	1607	0	1633	0	0	1786	1591
Flt Permitted	0.950			0.950				0.612			0.379	
Satd. Flow (perm)	1761	3500	0	1796	3592	1607	0	1013	0	0	710	1591
Right Turn on Red			No			No			No			No
Satd. Flow (RTOR)												
Link Speed (mph)		45			45			30			30	
Link Distance (ft)		560			728			219			359	
Travel Time (s)		8.5			11.0			5.0			8.2	
Peak Hour Factor	0.90	0.90	0.90	0.90	0.90	0.90	0.90	0.90	0.90	0.90	0.90	0.90
Heavy Vehicles (%)	2%	2%	2%	2%	2%	2%	2%	2%	2%	2%	2%	2%
Adj. Flow (vph)	111	2202	90	204	1770	263	96	6	270	231	6	78
Shared Lane Traffic (%)												
Lane Group Flow (vph)	111	2292	0	204	1770	263	0	372	0	0	237	78
Turn Type	Prot			Prot		Perm	Perm			Perm		pm+ov
Protected Phases	5	2		1	6			8			4	5
Permitted Phases						6	8			4		4
Detector Phase	5	2		1	6	6	8	8		4	4	5
Switch Phase												
Minimum Initial (s)	7.0	12.0		7.0	12.0	12.0	7.0	7.0		7.0	7.0	7.0
Minimum Split (s)	13.0	18.0		13.0	19.0	19.0	13.0	13.0		13.0	13.0	13.0
Total Split (s)	16.0	96.0	0.0	20.0	100.0	100.0	54.0	54.0	0.0	54.0	54.0	16.0
Total Split (%)	9.4%	56.5%	0.0%	11.8%	58.8%	58.8%	31.8%	31.8%	0.0%	31.8%	31.8%	9.4%
Maximum Green (s)	10.1	90.4		14.6	93.8	93.8	48.2	48.2		48.1	48.1	10.1
Yellow Time (s)	3.0	4.4		3.0	4.8	4.8	3.4	3.4		3.6	3.6	3.0
All-Red Time (s)	2.9	1.2		2.4	1.4	1.4	2.4	2.4		2.3	2.3	2.9
Lost Time Adjust (s)	-0.9	-0.6	-2.0	-0.4	-1.2	-1.2	-2.0	-0.8	-2.0	-2.0	-0.9	-0.9
Total Lost Time (s)	5.0	5.0	2.0	5.0	5.0	5.0	3.8	5.0	2.0	3.9	5.0	5.0
Lead/Lag	Lag	Lag		Lead	Lead	Lead						Lag
Lead-Lag Optimize?	Yes	Yes		Yes	Yes	Yes						Yes
Vehicle Extension (s)	1.0	2.0		1.0	2.0	2.0	1.0	1.0		1.0	1.0	1.0
Recall Mode	None	C-Max		None	C-Max	C-Max	None	None		None	None	None
Act Effct Green (s)	11.0	91.0		15.0	95.0	95.0		49.0			49.0	65.0
Actuated g/C Ratio	0.06	0.54		0.09	0.56	0.56		0.29			0.29	0.38
v/c Ratio	0.97	1.22		1.29	0.88	0.29		1.27			1.16	0.13
Control Delay	153.6	140.8		219.7	30.1	15.4		194.4			162.8	34.9
Queue Delay	0.0	0.0		0.0	5.3	0.0		0.0			0.0	0.0
Total Delay	153.6	140.8		219.7	35.5	15.4		194.4			162.8	34.9
LOS	F	F		F	D	B		F			F	C
Approach Delay		141.3			49.9			194.4			131.1	

Lanes, Volumes, Timings
 8: US 64 & SR 1634 (Carolina Village Rd)

2040 Design Year - No-Build
 Timing Plan: PM Peak



Lane Group	EBL	EBT	EBR	WBL	WBT	WBR	NBL	NBT	NBR	SBL	SBT	SBR
Approach LOS		F			D			F			F	
Queue Length 50th (ft)	126	~1645		~289	864	118		~521			~311	56
Queue Length 95th (ft)	#265	#1762		#469	711	167		#738			#500	98
Internal Link Dist (ft)		480			648			139			279	
Turn Bay Length (ft)	100			100								150
Base Capacity (vph)	114	1874		158	2007	898		292			205	608
Starvation Cap Reductn	0	0		0	194	0		0			0	0
Spillback Cap Reductn	0	0		0	0	0		0			0	0
Storage Cap Reductn	0	0		0	0	0		0			0	0
Reduced v/c Ratio	0.97	1.22		1.29	0.98	0.29		1.27			1.16	0.13

Intersection Summary

Area Type: Other
 Cycle Length: 170
 Actuated Cycle Length: 170
 Offset: 158 (93%), Referenced to phase 2:EBT and 6:WBT, Start of Green
 Natural Cycle: 170
 Control Type: Actuated-Coordinated
 Maximum v/c Ratio: 1.29
 Intersection Signal Delay: 106.1
 Intersection LOS: F
 Intersection Capacity Utilization 115.8%
 ICU Level of Service H
 Analysis Period (min) 15
 ~ Volume exceeds capacity, queue is theoretically infinite.
 Queue shown is maximum after two cycles.
 # 95th percentile volume exceeds capacity, queue may be longer.
 Queue shown is maximum after two cycles.

Splits and Phases: 8: US 64 & SR 1634 (Carolina Village Rd)



Lanes, Volumes, Timings
9: SR 1783 (Upward Rd) & I-26 NB On-Ramp

2040 Design Year - No-Build
Timing Plan: PM Peak



Lane Group	EBL	EBT	EBR	WBL	WBT	WBR	NBL	NBT	NBR	SBL	SBT	SBR
Lane Configurations	↖↗	↑↑			↑↓		↖	↗	↗			
Volume (vph)	579	718	0	0	634	132	589	0	237	0	0	0
Ideal Flow (vphpl)	1900	1900	1900	1900	1900	1900	1900	1900	1900	1900	1900	1900
Grade (%)		-3%			3%			4%			0%	
Storage Length (ft)	275		0	0		0	250		175	0		0
Storage Lanes	1		0	0		0	1		1	0		0
Taper Length (ft)	100		100	100		100	100		100	100		100
Lane Util. Factor	0.97	0.95	1.00	1.00	0.95	0.95	0.95	0.95	1.00	1.00	1.00	1.00
Frt					0.974				0.850			
Flt Protected	0.950						0.950	0.950				
Satd. Flow (prot)	3291	3592	0	0	3378	0	1648	1648	1552	0	0	0
Flt Permitted	0.950						0.950	0.950				
Satd. Flow (perm)	3291	3592	0	0	3378	0	1648	1648	1552	0	0	0
Right Turn on Red			No			No			No			No
Satd. Flow (RTOR)												
Link Speed (mph)		45			45			35			45	
Link Distance (ft)		630			322			532			658	
Travel Time (s)		9.5			4.9			10.4			10.0	
Peak Hour Factor	0.90	0.90	0.90	0.90	0.90	0.90	0.90	0.90	0.90	0.90	0.90	0.90
Heavy Vehicles (%)	8%	2%	5%	5%	2%	5%	2%	2%	2%	5%	5%	5%
Adj. Flow (vph)	643	798	0	0	704	147	654	0	263	0	0	0
Shared Lane Traffic (%)							50%					
Lane Group Flow (vph)	643	798	0	0	851	0	327	327	263	0	0	0
Turn Type	Prot						Split		Prot			
Protected Phases	5	2			6		8	8	8			
Permitted Phases												
Detector Phase	5	2			6		8	8	8			
Switch Phase												
Minimum Initial (s)	7.0	14.0			14.0		7.0	7.0	7.0			
Minimum Split (s)	14.0	22.0			21.0		19.0	19.0	19.0			
Total Split (s)	27.0	61.0	0.0	0.0	34.0	0.0	29.0	29.0	29.0	0.0	0.0	0.0
Total Split (%)	30.0%	67.8%	0.0%	0.0%	37.8%	0.0%	32.2%	32.2%	32.2%	0.0%	0.0%	0.0%
Maximum Green (s)	20.7	54.8			28.4		22.9	22.9	22.9			
Yellow Time (s)	3.0	5.1			4.6		3.6	3.6	3.6			
All-Red Time (s)	3.3	1.1			1.0		2.5	2.5	2.5			
Lost Time Adjust (s)	-1.3	-1.2	0.0	0.0	-0.6	0.0	-1.1	-1.1	-1.1	-2.0	0.0	0.0
Total Lost Time (s)	5.0	5.0	4.0	4.0	5.0	4.0	5.0	5.0	5.0	2.0	4.0	4.0
Lead/Lag	Lag				Lead							
Lead-Lag Optimize?	Yes				Yes							
Vehicle Extension (s)	2.0	2.0			2.0		2.0	2.0	2.0			
Minimum Gap (s)	3.0	3.1			3.1		3.0	3.0	3.0			
Time Before Reduce (s)	0.0	15.0			15.0		0.0	0.0	0.0			
Time To Reduce (s)	0.0	45.0			45.0		0.0	0.0	0.0			
Recall Mode	None	C-Max			C-Max		None	None	None			
Act Effct Green (s)	22.0	58.2			31.2		21.8	21.8	21.8			
Actuated g/C Ratio	0.24	0.65			0.35		0.24	0.24	0.24			
v/c Ratio	0.80	0.34			0.73		0.82	0.82	0.70			
Control Delay	31.7	2.8			30.7		49.5	49.5	41.4			
Queue Delay	0.0	0.0			0.0		0.0	0.0	0.0			

Lanes, Volumes, Timings
 9: SR 1783 (Upward Rd) & I-26 NB On-Ramp

2040 Design Year - No-Build
 Timing Plan: PM Peak



Lane Group	EBL	EBT	EBR	WBL	WBT	WBR	NBL	NBT	NBR	SBL	SBT	SBR
Total Delay	31.7	2.8			30.7		49.5	49.5	41.4			
LOS	C	A			C		D	D	D			
Approach Delay		15.7			30.7			47.2				
Approach LOS		B			C			D				
Queue Length 50th (ft)	181	27			228		178	178	132			
Queue Length 95th (ft)	#250	33			302		#307	#307	216			
Internal Link Dist (ft)		550			242			452			578	
Turn Bay Length (ft)	275						250		175			
Base Capacity (vph)	804	2323			1171		439	439	414			
Starvation Cap Reductn	0	0			0		0	0	0			
Spillback Cap Reductn	0	0			0		0	0	0			
Storage Cap Reductn	0	0			0		0	0	0			
Reduced v/c Ratio	0.80	0.34			0.73		0.74	0.74	0.64			

Intersection Summary

Area Type: Other
 Cycle Length: 90
 Actuated Cycle Length: 90
 Offset: 1 (1%), Referenced to phase 2:EBT and 6:WBT, Start of Green
 Natural Cycle: 60
 Control Type: Actuated-Coordinated
 Maximum v/c Ratio: 0.82
 Intersection Signal Delay: 28.7
 Intersection LOS: C
 Intersection Capacity Utilization 68.2%
 ICU Level of Service C
 Analysis Period (min) 15
 # 95th percentile volume exceeds capacity, queue may be longer.
 Queue shown is maximum after two cycles.

Splits and Phases: 9: SR 1783 (Upward Rd) & I-26 NB On-Ramp

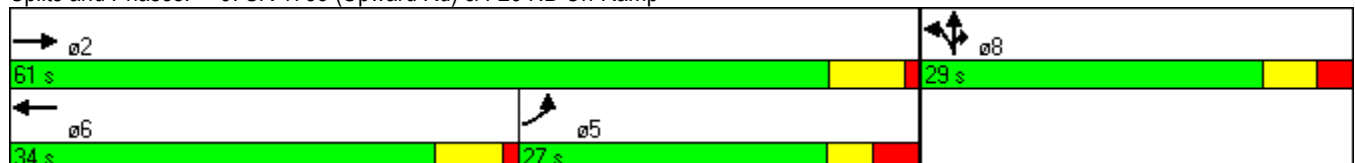

Lanes, Volumes, Timings
 10: SR 1783 (Upward Rd) & I-26 SB Off-Ramp

2040 Design Year - No-Build

Timing Plan: PM Peak



Lane Group	EBL	EBT	EBR	WBL	WBT	WBR	NBL	NBT	NBR	SBL	SBT	SBR
Lane Configurations		↑↑↑	↗	↘	↑↑						↖	↗↗
Volume (vph)	0	1163	612	188	1035	0	0	0	0	134	0	446
Ideal Flow (vphpl)	1900	1900	1900	1900	1900	1900	1900	1900	1900	1900	1900	1900
Grade (%)		4%			-4%			0%			5%	
Storage Length (ft)	275		0	150		0	0		0	250		0
Storage Lanes	1		1	1		0	0		0	1		2
Taper Length (ft)	100		100	100		100	100		100	100		100
Lane Util. Factor	1.00	0.91	1.00	1.00	0.95	1.00	1.00	1.00	1.00	1.00	1.00	0.88
Frt			0.850									0.850
Flt Protected				0.950							0.950	
Satd. Flow (prot)	0	4984	1465	1705	3610	0	0	0	0	0	1725	2717
Flt Permitted				0.144							0.950	
Satd. Flow (perm)	0	4984	1465	258	3610	0	0	0	0	0	1725	2717
Right Turn on Red			No			No			No			No
Satd. Flow (RTOR)												
Link Speed (mph)		45			45			45			35	
Link Distance (ft)		549			630			547			651	
Travel Time (s)		8.3			9.5			8.3			12.7	
Peak Hour Factor	0.90	0.90	0.90	0.90	0.90	0.90	0.90	0.90	0.90	0.90	0.90	0.90
Heavy Vehicles (%)	5%	2%	8%	8%	2%	5%	5%	5%	5%	2%	2%	2%
Adj. Flow (vph)	0	1292	680	209	1150	0	0	0	0	149	0	496
Shared Lane Traffic (%)												
Lane Group Flow (vph)	0	1292	680	209	1150	0	0	0	0	0	149	496
Turn Type			Perm		pm+pt					Split		Prot
Protected Phases		2		1	6					4	4	4
Permitted Phases			2		6							
Detector Phase		2		2	1		6			4	4	4
Switch Phase												
Minimum Initial (s)		14.0		14.0	7.0		14.0			7.0	7.0	7.0
Minimum Split (s)		20.0		20.0	14.0		21.0			13.0	13.0	13.0
Total Split (s)	0.0	52.0	52.0	14.0	66.0	0.0	0.0	0.0	0.0	24.0	24.0	24.0
Total Split (%)	0.0%	57.8%	57.8%	15.6%	73.3%	0.0%	0.0%	0.0%	0.0%	26.7%	26.7%	26.7%
Maximum Green (s)		46.4		46.4	7.6	59.6				18.1	18.1	18.1
Yellow Time (s)		4.5		4.5	3.0	5.2				3.6	3.6	3.6
All-Red Time (s)		1.1		1.1	3.4	1.2				2.3	2.3	2.3
Lost Time Adjust (s)	0.0	-0.6	-0.6	-1.4	-1.4	-2.0	0.0	0.0	0.0	-2.0	-0.9	-0.9
Total Lost Time (s)	4.0	5.0	5.0	5.0	5.0	2.0	4.0	4.0	4.0	3.9	5.0	5.0
Lead/Lag		Lag		Lag	Lead							
Lead-Lag Optimize?		Yes		Yes	Yes							
Vehicle Extension (s)		2.0		2.0	2.0		2.0			2.0	2.0	2.0
Minimum Gap (s)		3.1		3.1	3.0		3.1			3.0	3.0	3.0
Time Before Reduce (s)		15.0		15.0	0.0	15.0				0.0	0.0	0.0
Time To Reduce (s)		45.0		45.0	0.0	45.0				0.0	0.0	0.0
Recall Mode		C-Max		C-Max	None	C-Max				None	None	None
Act Effct Green (s)		47.6		47.6	61.5	61.5					18.5	18.5
Actuated g/C Ratio		0.53		0.53	0.68	0.68					0.21	0.21
v/c Ratio		0.49		0.88	0.66	0.47					0.42	0.89
Control Delay		14.4		34.0	16.4	1.5					35.0	54.0
Queue Delay		0.0		0.0	0.0	0.0					0.0	0.0

Lanes, Volumes, Timings
 10: SR 1783 (Upward Rd) & I-26 SB Off-Ramp

2040 Design Year - No-Build
 Timing Plan: PM Peak



Lane Group	EBL	EBT	EBR	WBL	WBT	WBR	NBL	NBT	NBR	SBL	SBT	SBR
Total Delay		14.4	34.0	16.4	1.5						35.0	54.0
LOS		B	C	B	A						D	D
Approach Delay		21.2			3.8						49.6	
Approach LOS		C			A						D	
Queue Length 50th (ft)		164	327	19	0						74	155
Queue Length 95th (ft)		201	#566	m46	0						131	#250
Internal Link Dist (ft)		469			550			467			571	
Turn Bay Length (ft)				150								
Base Capacity (vph)		2635	774	321	2465						364	574
Starvation Cap Reductn		0	0	0	0						0	0
Spillback Cap Reductn		0	0	0	0						0	0
Storage Cap Reductn		0	0	0	0						0	0
Reduced v/c Ratio		0.49	0.88	0.65	0.47						0.41	0.86

Intersection Summary

Area Type: Other
 Cycle Length: 90
 Actuated Cycle Length: 90
 Offset: 0 (0%), Referenced to phase 2:EBT and 6:WBTL, Start of Green
 Natural Cycle: 80
 Control Type: Actuated-Coordinated
 Maximum v/c Ratio: 0.89
 Intersection Signal Delay: 19.8
 Intersection LOS: B
 Intersection Capacity Utilization 68.2%
 ICU Level of Service C
 Analysis Period (min) 15
 # 95th percentile volume exceeds capacity, queue may be longer.
 Queue shown is maximum after two cycles.
 m Volume for 95th percentile queue is metered by upstream signal.

Splits and Phases: 10: SR 1783 (Upward Rd) & I-26 SB Off-Ramp



2040 Build 6 Lane

Lanes, Volumes, Timings
1: NC 146 (Long Shoals Rd) & I-26 NB On-Ramp

2040 Design Year - Build 6 Lanes

Timing Plan: AM Peak

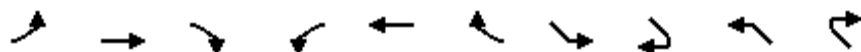

Lane Group	EBL	EBT	EBR2	WBL	WBT	WBR2	SEL	SER2	NWL	NWR2
Lane Configurations	↗↘	↗↗	↗	↗↘	↗↗	↗	↗↘	↗	↗↘	↗
Volume (vph)	325	864	380	590	1142	859	829	415	386	454
Ideal Flow (vphpl)	1900	1900	1900	1900	1900	1900	1900	1900	1900	1900
Grade (%)		3%			-7%					
Storage Length (ft)	450			350			0		675	
Storage Lanes	1			2			2		1	
Taper Length (ft)	100			100			100		100	
Lane Util. Factor	0.97	0.95	1.00	0.97	0.95	1.00	0.97	1.00	0.97	1.00
Frt			0.850			0.850		0.850		0.850
Flt Protected	0.950			0.950			0.950		0.950	
Satd. Flow (prot)	3224	3452	1487	3387	3663	1562	3519	1607	3434	1599
Flt Permitted	0.950			0.950			0.950		0.950	
Satd. Flow (perm)	3224	3452	1487	3387	3663	1562	3519	1607	3434	1599
Right Turn on Red			No			No		No		No
Satd. Flow (RTOR)										
Link Speed (mph)		45			45					
Link Distance (ft)		1009			964					
Travel Time (s)		15.3			14.6					
Peak Hour Factor	0.90	0.90	0.90	0.90	0.90	0.90	0.90	0.90	0.90	0.90
Heavy Vehicles (%)	7%	3%	7%	7%	2%	7%	2%	3%	3%	2%
Adj. Flow (vph)	361	960	422	656	1269	954	921	461	429	504
Shared Lane Traffic (%)										
Lane Group Flow (vph)	361	960	422	656	1269	954	921	461	429	504
Turn Type	Prot		Free	Prot		Free	Prot	custom	Prot	Free
Protected Phases	5	2		1	6		4		8	
Permitted Phases			Free			Free		4		Free
Detector Phase	5	2		1	6		4	4	8	
Switch Phase										
Minimum Initial (s)	7.0	12.0		7.0	12.0		7.0	7.0	7.0	
Minimum Split (s)	16.0	20.0		15.0	21.0		16.0	16.0	15.0	
Total Split (s)	18.0	39.0	0.0	24.0	45.0	0.0	37.0	37.0	37.0	0.0
Total Split (%)	18.0%	39.0%	0.0%	24.0%	45.0%	0.0%	37.0%	37.0%	37.0%	0.0%
Maximum Green (s)	9.8	31.5		16.3	36.0		28.9	28.9	29.0	
Yellow Time (s)	3.4	4.3		4.0	5.2		3.8	3.8	3.7	
All-Red Time (s)	4.8	3.2		3.7	3.8		4.3	4.3	4.3	
Lost Time Adjust (s)	-3.2	-2.5	-2.5	-2.7	-4.0	-4.0	-3.1	-3.1	-3.0	0.0
Total Lost Time (s)	5.0	5.0	1.5	5.0	5.0	0.0	5.0	5.0	5.0	4.0
Lead/Lag	Lead	Lag		Lead	Lag					
Lead-Lag Optimize?	Yes	Yes		Yes	Yes					
Vehicle Extension (s)	2.0	6.0		2.0	6.0		2.0	2.0	2.0	
Minimum Gap (s)	3.0	3.0		3.0	3.0		3.0	3.0	3.0	
Time Before Reduce (s)	0.0	15.0		0.0	15.0		0.0	0.0	0.0	
Time To Reduce (s)	0.0	30.0		0.0	30.0		0.0	0.0	0.0	
Recall Mode	None	C-Max		None	C-Max		None	None	None	
Act Effct Green (s)	13.4	34.0	100.0	19.7	40.3	100.0	31.3	31.3	31.3	100.0
Actuated g/C Ratio	0.13	0.34	1.00	0.20	0.40	1.00	0.31	0.31	0.31	1.00
v/c Ratio	0.83	0.82	0.28	0.98	0.86	0.61	0.84	0.92	0.40	0.32
Control Delay	60.3	37.1	0.5	72.0	34.7	1.8	39.9	58.3	28.1	0.5
Queue Delay	0.0	0.0	0.0	0.0	0.0	0.0	0.0	0.0	0.0	0.0

Lanes, Volumes, Timings
 1: NC 146 (Long Shoals Rd) & I-26 NB On-Ramp

2040 Design Year - Build 6 Lanes

Timing Plan: AM Peak

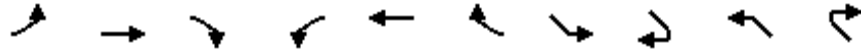

Lane Group	EBL	EBT	EBR2	WBL	WBT	WBR2	SEL	SER2	NWL	NWR2
Total Delay	60.3	37.1	0.5	72.0	34.7	1.8	39.9	58.3	28.1	0.5
LOS	E	D	A	E	C	A	D	E	C	A
Approach Delay	33.0			32.3						
Approach LOS	C			C						
Queue Length 50th (ft)	118	291	0	~223	383	0	277	278	108	0
Queue Length 95th (ft)	#195	373	0	#341	478	0	354	#465	151	0
Internal Link Dist (ft)	929			884						
Turn Bay Length (ft)	450		300	350		300		425	675	575
Base Capacity (vph)	433	1174	1487	668	1476	1562	1126	514	1099	1599
Starvation Cap Reductn	0	0	0	0	0	0	0	0	0	0
Spillback Cap Reductn	0	0	0	0	0	0	0	0	0	0
Storage Cap Reductn	0	0	0	0	0	0	0	0	0	0
Reduced v/c Ratio	0.83	0.82	0.28	0.98	0.86	0.61	0.82	0.90	0.39	0.32

Intersection Summary

Area Type: Other
 Cycle Length: 100
 Actuated Cycle Length: 100
 Offset: 0 (0%), Referenced to phase 2:EBT and 6:WBT, Start of Green
 Natural Cycle: 90
 Control Type: Actuated-Coordinated
 Maximum v/c Ratio: 0.98
 Intersection Signal Delay: 32.6
 Intersection LOS: C
 Intersection Capacity Utilization 79.9%
 ICU Level of Service D
 Analysis Period (min) 15
 ~ Volume exceeds capacity, queue is theoretically infinite.
 Queue shown is maximum after two cycles.
 # 95th percentile volume exceeds capacity, queue may be longer.
 Queue shown is maximum after two cycles.

Splits and Phases: 1: NC 146 (Long Shoals Rd) & I-26 NB On-Ramp

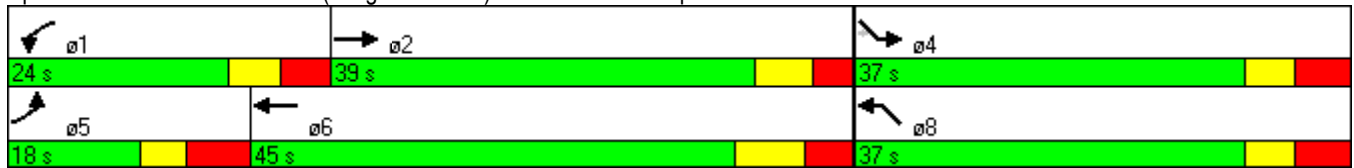

Lanes, Volumes, Timings
2: I-26 NB On-Ramp & US 25 (Asheville Highway)

2040 Design Year - Build 6 Lanes

Timing Plan: AM Peak



Lane Group	EBL	EBT	EBR	WBL	WBT	WBR	NBL	NBT	NBR	SBL	SBT	SBR
Lane Configurations				↙		↗	↗	↗			↗	↗
Volume (vph)	0	0	0	264	0	490	748	1163	0	0	1748	273
Ideal Flow (vphpl)	1900	1900	1900	1900	1900	1900	1900	1900	1900	1900	1900	1900
Grade (%)		0%			2%			-1%			2%	
Storage Length (ft)	0		0	0		150	0		0	0		300
Storage Lanes	0		0	1		2	1		0	0		1
Taper Length (ft)	100		100	100		100	100		100	100		100
Lane Util. Factor	1.00	1.00	1.00	1.00	1.00	0.88	1.00	0.95	1.00	1.00	0.95	1.00
Frt						0.850						0.850
Flt Protected				0.950			0.950					
Satd. Flow (prot)	0	0	0	1735	0	2706	1680	3489	0	0	3436	1480
Flt Permitted				0.950			0.950					
Satd. Flow (perm)	0	0	0	1735	0	2706	1680	3489	0	0	3436	1480
Right Turn on Red			No			Yes			No			No
Satd. Flow (RTOR)						211						
Link Speed (mph)		45			35			45				45
Link Distance (ft)		533			612			601				596
Travel Time (s)		8.1			11.9			9.1				9.0
Peak Hour Factor	0.90	0.90	0.90	0.90	0.90	0.90	0.90	0.90	0.90	0.90	0.90	0.90
Heavy Vehicles (%)	5%	5%	5%	3%	5%	4%	8%	4%	5%	5%	4%	8%
Adj. Flow (vph)	0	0	0	293	0	544	831	1292	0	0	1942	303
Shared Lane Traffic (%)												
Lane Group Flow (vph)	0	0	0	293	0	544	831	1292	0	0	1942	303
Turn Type				Prot		custom	Prot					Free
Protected Phases				4			5	2				6
Permitted Phases						4						Free
Detector Phase				4		4	5	2				6
Switch Phase												
Minimum Initial (s)				7.0		7.0	7.0	12.0				12.0
Minimum Split (s)				13.0		13.0	14.0	19.0				18.0
Total Split (s)	0.0	0.0	0.0	20.0	0.0	20.0	42.0	90.0	0.0	0.0	48.0	0.0
Total Split (%)	0.0%	0.0%	0.0%	18.2%	0.0%	18.2%	38.2%	81.8%	0.0%	0.0%	43.6%	0.0%
Maximum Green (s)				14.0		14.0	35.6	83.9				42.7
Yellow Time (s)				3.7		3.7	3.0	4.6				4.3
All-Red Time (s)				2.3		2.3	3.4	1.5				1.0
Lost Time Adjust (s)	-2.0	0.0	0.0	-1.0	0.0	-1.0	-1.4	-1.1	0.0	0.0	-0.3	0.0
Total Lost Time (s)	2.0	4.0	4.0	5.0	4.0	5.0	5.0	5.0	4.0	4.0	5.0	4.0
Lead/Lag							Lag					Lead
Lead-Lag Optimize?							Yes					Yes
Vehicle Extension (s)				2.0		2.0	2.0	8.0				8.0
Minimum Gap (s)				3.0		3.0	3.0	5.5				5.5
Time Before Reduce (s)				0.0		0.0	0.0	15.0				15.0
Time To Reduce (s)				0.0		0.0	0.0	50.0				50.0
Recall Mode				None		None	None	C-Max				C-Max
Act Effct Green (s)				15.0		15.0	37.0	85.0			43.0	110.0
Actuated g/C Ratio				0.14		0.14	0.34	0.77			0.39	1.00
v/c Ratio				1.24		0.99	1.47	0.48			1.45	0.20
Control Delay				177.8		65.1	236.0	1.2			233.8	0.3
Queue Delay				0.0		0.0	0.0	0.5			0.0	0.0

Lanes, Volumes, Timings
 2: I-26 NB On-Ramp & US 25 (Asheville Highway)

2040 Design Year - Build 6 Lanes

Timing Plan: AM Peak



Lane Group	EBL	EBT	EBR	WBL	WBT	WBR	NBL	NBT	NBR	SBL	SBT	SBR
Total Delay				177.8		65.1	236.0	1.7			233.8	0.3
LOS				F		E	F	A			F	A
Approach Delay								93.4			202.3	
Approach LOS								F			F	
Queue Length 50th (ft)				~257		140	~834	12			~984	0
Queue Length 95th (ft)				#428		#267	m#464	m15			#1123	0
Internal Link Dist (ft)		453			532			521			516	
Turn Bay Length (ft)						150						300
Base Capacity (vph)				237		551	565	2696			1343	1480
Starvation Cap Reductn				0		0	0	836			0	0
Spillback Cap Reductn				0		0	0	0			0	0
Storage Cap Reductn				0		0	0	0			0	0
Reduced v/c Ratio				1.24		0.99	1.47	0.69			1.45	0.20

Intersection Summary

Area Type: Other
 Cycle Length: 110
 Actuated Cycle Length: 110
 Offset: 49 (45%), Referenced to phase 2:NBT and 6:SBT, Start of Green
 Natural Cycle: 220
 Control Type: Actuated-Coordinated
 Maximum v/c Ratio: 1.47
 Intersection Signal Delay: 142.1
 Intersection LOS: F
 Intersection Capacity Utilization 116.9%
 ICU Level of Service H
 Analysis Period (min) 15
 ~ Volume exceeds capacity, queue is theoretically infinite.
 Queue shown is maximum after two cycles.
 # 95th percentile volume exceeds capacity, queue may be longer.
 Queue shown is maximum after two cycles.
 m Volume for 95th percentile queue is metered by upstream signal.

Splits and Phases: 2: I-26 NB On-Ramp & US 25 (Asheville Highway)

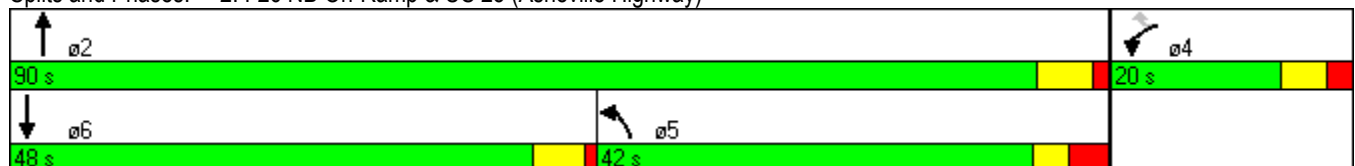

Lanes, Volumes, Timings
 3: I-26 SB Off-Ramp & US 25 (Asheville Highway)

2040 Design Year - Build 6 Lanes

Timing Plan: AM Peak



Lane Group	EBL	EBT	EBR	WBL	WBT	WBR	NBL	NBT	NBR	SBL	SBT	SBR
Lane Configurations												
Volume (vph)	269	0	931	0	0	0	0	1642	262	616	1396	0
Ideal Flow (vphpl)	1900	1900	1900	1900	1900	1900	1900	1900	1900	1900	1900	1900
Grade (%)		3%			0%			4%			1%	
Storage Length (ft)	0		100	0		0	0		500	0		0
Storage Lanes	1		1	0		0	0		1	1		0
Taper Length (ft)	100		100	100		100	100		100	100		100
Lane Util. Factor	1.00	1.00	1.00	1.00	1.00	1.00	1.00	0.95	1.00	1.00	0.95	1.00
Frt			0.850						0.850			
Flt Protected	0.950									0.950		
Satd. Flow (prot)	1710	0	1544	0	0	0	0	3435	1465	1663	3487	0
Flt Permitted	0.950									0.950		
Satd. Flow (perm)	1710	0	1544	0	0	0	0	3435	1465	1663	3487	0
Right Turn on Red			No			No			No			No
Satd. Flow (RTOR)												
Link Speed (mph)		35			45			45			45	
Link Distance (ft)		471			598			795			601	
Travel Time (s)		9.2			9.1			12.0			9.1	
Peak Hour Factor	0.90	0.90	0.90	0.90	0.90	0.90	0.90	0.90	0.90	0.90	0.90	0.90
Heavy Vehicles (%)	4%	5%	3%	5%	5%	5%	5%	3%	8%	8%	3%	5%
Adj. Flow (vph)	299	0	1034	0	0	0	0	1824	291	684	1551	0
Shared Lane Traffic (%)												
Lane Group Flow (vph)	299	0	1034	0	0	0	0	1824	291	684	1551	0
Turn Type	Prot		custom						Free	Prot		
Protected Phases	4		4					2		1	6	
Permitted Phases									Free			
Detector Phase	4		4					2		1	6	
Switch Phase												
Minimum Initial (s)	7.0		7.0					12.0		7.0	12.0	
Minimum Split (s)	13.0		13.0					18.0		14.0	18.0	
Total Split (s)	43.0	0.0	43.0	0.0	0.0	0.0	0.0	42.0	0.0	25.0	67.0	0.0
Total Split (%)	39.1%	0.0%	39.1%	0.0%	0.0%	0.0%	0.0%	38.2%	0.0%	22.7%	60.9%	0.0%
Maximum Green (s)	37.0		37.0					36.3		18.5	61.3	
Yellow Time (s)	4.0		4.0					4.7		4.0	4.7	
All-Red Time (s)	2.0		2.0					1.0		2.5	1.0	
Lost Time Adjust (s)	-1.0	-2.0	-1.0	-2.0	-2.0	-2.0	-2.0	-0.7	-0.7	-1.5	-0.7	-2.0
Total Lost Time (s)	5.0	2.0	5.0	2.0	2.0	2.0	2.0	5.0	3.3	5.0	5.0	2.0
Lead/Lag								Lag		Lead		
Lead-Lag Optimize?								Yes		Yes		
Vehicle Extension (s)	2.0		2.0					8.0		2.0	8.0	
Minimum Gap (s)	3.0		3.0					5.5		3.0	5.5	
Time Before Reduce (s)	0.0		0.0					15.0		0.0	15.0	
Time To Reduce (s)	0.0		0.0					50.0		0.0	50.0	
Recall Mode	None		None					C-Max		None	C-Max	
Act Effct Green (s)	38.0		38.0					37.0	110.0	20.0	62.0	
Actuated g/C Ratio	0.35		0.35					0.34	1.00	0.18	0.56	
v/c Ratio	0.51		1.94					1.58	0.20	2.26	0.79	
Control Delay	32.2		454.4					293.4	0.3	598.1	3.6	
Queue Delay	0.0		0.0					0.0	0.0	0.0	1.2	

Lanes, Volumes, Timings
 3: I-26 SB Off-Ramp & US 25 (Asheville Highway)

2040 Design Year - Build 6 Lanes

Timing Plan: AM Peak



Lane Group	EBL	EBT	EBR	WBL	WBT	WBR	NBL	NBT	NBR	SBL	SBT	SBR
Total Delay	32.2		454.4					293.4	0.3	598.1	4.7	
LOS	C		F					F	A	F	A	
Approach Delay								253.1			186.3	
Approach LOS								F			F	
Queue Length 50th (ft)	166		~1130					~966	0	~805	0	
Queue Length 95th (ft)	252		#1379					#1104	0	m#500	m0	
Internal Link Dist (ft)		391			518			715				521
Turn Bay Length (ft)			100						500			
Base Capacity (vph)	591		533					1155	1465	302	1965	
Starvation Cap Reductn	0		0					0	0	0	204	
Spillback Cap Reductn	0		0					0	0	0	0	
Storage Cap Reductn	0		0					0	0	0	0	
Reduced v/c Ratio	0.51		1.94					1.58	0.20	2.26	0.88	

Intersection Summary

Area Type: Other
 Cycle Length: 110
 Actuated Cycle Length: 110
 Offset: 64 (58%), Referenced to phase 2:NBT and 6:SBT, Start of Green
 Natural Cycle: 200
 Control Type: Actuated-Coordinated
 Maximum v/c Ratio: 2.26
 Intersection Signal Delay: 251.8
 Intersection LOS: F
 Intersection Capacity Utilization 116.9%
 ICU Level of Service H
 Analysis Period (min) 15
 ~ Volume exceeds capacity, queue is theoretically infinite.
 Queue shown is maximum after two cycles.
 # 95th percentile volume exceeds capacity, queue may be longer.
 Queue shown is maximum after two cycles.
 m Volume for 95th percentile queue is metered by upstream signal.

Splits and Phases: 3: I-26 SB Off-Ramp & US 25 (Asheville Highway)

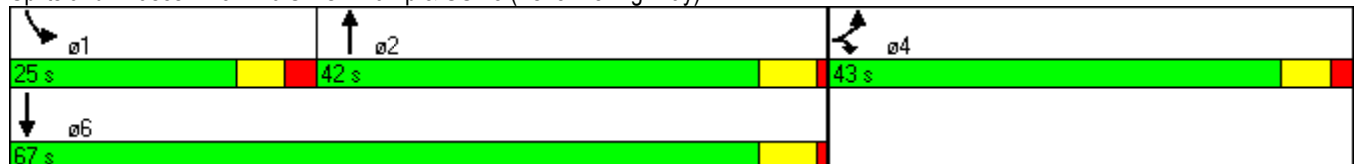

Lanes, Volumes, Timings
4: I-26 NB Ramps & Balfour Pkwy

2040 Design Year - Build 6 Lanes

Timing Plan: AM Peak



Lane Group	EBL	EBT	EBR	WBL	WBT	WBR	NBL	NBT	NBR	SBL	SBT	SBR
Lane Configurations			↗↗			↗	↗	↗↗			↗↗	↗
Volume (vph)	0	0	726	0	0	199	329	1426	0	0	1168	829
Ideal Flow (vphpl)	1900	1900	1900	1900	1900	1900	1900	1900	1900	1900	1900	1900
Storage Length (ft)	0		0	0		0	250		0	0		250
Storage Lanes	0		2	0		1	1		0	0		1
Taper Length (ft)	100		100	100		100	100		100	100		100
Lane Util. Factor	1.00	1.00	0.88	1.00	1.00	1.00	1.00	0.95	1.00	1.00	0.95	1.00
Frt			0.850			0.865						0.850
Flt Protected							0.950					
Satd. Flow (prot)	0	0	2787	0	0	1611	1671	3539	0	0	3539	1495
Flt Permitted							0.950					
Satd. Flow (perm)	0	0	2787	0	0	1611	1671	3539	0	0	3539	1495
Right Turn on Red			No			No			No			No
Satd. Flow (RTOR)												
Link Speed (mph)		25			45			45				45
Link Distance (ft)		393			429			690				522
Travel Time (s)		10.7			6.5			10.5				7.9
Peak Hour Factor	0.90	0.90	0.90	0.90	0.90	0.90	0.90	0.90	0.90	0.90	0.90	0.90
Heavy Vehicles (%)	5%	5%	2%	5%	5%	2%	8%	2%	5%	5%	2%	8%
Adj. Flow (vph)	0	0	807	0	0	221	366	1584	0	0	1298	921
Shared Lane Traffic (%)												
Lane Group Flow (vph)	0	0	807	0	0	221	366	1584	0	0	1298	921
Turn Type			Over			Free	Prot					Perm
Protected Phases			5				5	Free				6
Permitted Phases						Free						6
Detector Phase			5				5					6
Switch Phase												
Minimum Initial (s)			7.0				7.0				12.0	12.0
Minimum Split (s)			14.0				14.0				19.0	19.0
Total Split (s)	0.0	0.0	30.0	0.0	0.0	0.0	30.0	0.0	0.0	0.0	60.0	60.0
Total Split (%)	0.0%	0.0%	33.3%	0.0%	0.0%	0.0%	33.3%	0.0%	0.0%	0.0%	66.7%	66.7%
Maximum Green (s)			23.0				23.0				53.0	53.0
Yellow Time (s)			5.0				5.0				5.0	5.0
All-Red Time (s)			2.0				2.0				2.0	2.0
Lost Time Adjust (s)	-2.0	-2.0	-2.0	-2.0	-2.0	-2.0	-2.0	-2.0	-2.0	-2.0	-2.0	-2.0
Total Lost Time (s)	2.0	2.0	5.0	2.0	2.0	2.0	5.0	2.0	2.0	2.0	5.0	5.0
Lead/Lag			Lead				Lead				Lag	Lag
Lead-Lag Optimize?			Yes				Yes				Yes	Yes
Vehicle Extension (s)			3.0				3.0				3.0	3.0
Recall Mode			None				None				C-Max	C-Max
Act Effct Green (s)			25.0			90.0	25.0	90.0			55.0	55.0
Actuated g/C Ratio			0.28			1.00	0.28	1.00			0.61	0.61
v/c Ratio			1.04			0.14	0.79	0.45			0.60	1.01
Control Delay			77.3			0.2	33.9	0.3			12.2	51.2
Queue Delay			0.0			0.0	0.0	0.0			0.0	0.0
Total Delay			77.3			0.2	33.9	0.3			12.2	51.2
LOS			E			A	C	A			B	D
Approach Delay								6.6			28.4	
Approach LOS								A			C	

Lanes, Volumes, Timings
 4: I-26 NB Ramps & Balfour Pkwy

2040 Design Year - Build 6 Lanes

Timing Plan: AM Peak



Lane Group	EBL	EBT	EBR	WBL	WBT	WBR	NBL	NBT	NBR	SBL	SBT	SBR
Queue Length 50th (ft)			~285			0	186	0			217	~494
Queue Length 95th (ft)			#411			0	m240	m0			278	#784
Internal Link Dist (ft)		313			349			610			442	
Turn Bay Length (ft)							250					250
Base Capacity (vph)			774			1611	464	3539			2163	914
Starvation Cap Reductn			0			0	0	0			0	0
Spillback Cap Reductn			0			0	0	0			0	0
Storage Cap Reductn			0			0	0	0			0	0
Reduced v/c Ratio			1.04			0.14	0.79	0.45			0.60	1.01

Intersection Summary

Area Type: Other
 Cycle Length: 90
 Actuated Cycle Length: 90
 Offset: 41 (46%), Referenced to phase 6:SBT, Start of Green
 Natural Cycle: 80
 Control Type: Actuated-Coordinated
 Maximum v/c Ratio: 1.04
 Intersection Signal Delay: 26.6 Intersection LOS: C
 Intersection Capacity Utilization 77.9% ICU Level of Service D
 Analysis Period (min) 15
 ~ Volume exceeds capacity, queue is theoretically infinite.
 Queue shown is maximum after two cycles.
 # 95th percentile volume exceeds capacity, queue may be longer.
 Queue shown is maximum after two cycles.
 m Volume for 95th percentile queue is metered by upstream signal.





















Splits and Phases: 4: I-26 NB Ramps & Balfour Pkwy



Lanes, Volumes, Timings
5: I-26 SB Ramps & Balfour Pkwy

2040 Design Year - Build 6 Lanes

Timing Plan: AM Peak

												
Lane Group	EBL	EBT	EBR	WBL	WBT	WBR	NBL	NBT	NBR	SBL	SBT	SBR
Lane Configurations						 		 			 	
Volume (vph)	0	0	435	0	0	791	0	964	703	286	1608	0
Ideal Flow (vphpl)	1900	1900	1900	1900	1900	1900	1900	1900	1900	1900	1900	1900
Storage Length (ft)	0		0	0		0	0		250	250		0
Storage Lanes	0		1	0		2	0		1	1		0
Taper Length (ft)	100		100	100		100	100		100	100		100
Lane Util. Factor	1.00	1.00	1.00	1.00	1.00	0.88	1.00	0.95	1.00	1.00	0.95	1.00
Frt			0.865			0.850			0.850			
Flt Protected										0.950		
Satd. Flow (prot)	0	0	1611	0	0	2787	0	3539	1495	1671	3539	0
Flt Permitted										0.950		
Satd. Flow (perm)	0	0	1611	0	0	2787	0	3539	1495	1671	3539	0
Right Turn on Red			No			No			No			No
Satd. Flow (RTOR)												
Link Speed (mph)		45			25			45			45	
Link Distance (ft)		642			361			480			690	
Travel Time (s)		9.7			9.8			7.3			10.5	
Peak Hour Factor	0.90	0.90	0.90	0.90	0.90	0.90	0.90	0.90	0.90	0.90	0.90	0.90
Heavy Vehicles (%)	5%	5%	2%	5%	5%	2%	5%	2%	8%	8%	2%	5%
Adj. Flow (vph)	0	0	483	0	0	879	0	1071	781	318	1787	0
Shared Lane Traffic (%)												
Lane Group Flow (vph)	0	0	483	0	0	879	0	1071	781	318	1787	0
Turn Type			Free			Over			Perm	Prot		
Protected Phases						1		2		1	Free	
Permitted Phases			Free						2			
Detector Phase						1		2	2	1		
Switch Phase												
Minimum Initial (s)						7.0		12.0	12.0	7.0		
Minimum Split (s)						14.0		19.0	19.0	14.0		
Total Split (s)	0.0	0.0	0.0	0.0	0.0	35.0	0.0	55.0	55.0	35.0	0.0	0.0
Total Split (%)	0.0%	0.0%	0.0%	0.0%	0.0%	38.9%	0.0%	61.1%	61.1%	38.9%	0.0%	0.0%
Maximum Green (s)						28.0		48.0	48.0	28.0		
Yellow Time (s)						5.0		5.0	5.0	5.0		
All-Red Time (s)						2.0		2.0	2.0	2.0		
Lost Time Adjust (s)	-2.0	-2.0	-2.0	-2.0	-2.0	-2.0	-2.0	-2.0	-2.0	-2.0	-2.0	-2.0
Total Lost Time (s)	2.0	2.0	2.0	2.0	2.0	5.0	2.0	5.0	5.0	5.0	2.0	2.0
Lead/Lag						Lead		Lag	Lag	Lead		
Lead-Lag Optimize?						Yes		Yes	Yes	Yes		
Vehicle Extension (s)						3.0		3.0	3.0	3.0		
Recall Mode						None		C-Max	C-Max	None		
Act Effct Green (s)			90.0			30.0		50.0	50.0	30.0	90.0	
Actuated g/C Ratio			1.00			0.33		0.56	0.56	0.33	1.00	
v/c Ratio			0.30			0.95		0.54	0.94	0.57	0.50	
Control Delay			0.5			49.5		14.1	40.1	23.2	0.3	
Queue Delay			0.0			0.0		0.0	0.0	0.0	0.0	
Total Delay			0.5			49.5		14.1	40.1	23.2	0.3	
LOS			A			D		B	D	C	A	
Approach Delay								25.1			3.8	
Approach LOS								C			A	

Lanes, Volumes, Timings
5: I-26 SB Ramps & Balfour Pkwy

2040 Design Year - Build 6 Lanes

Timing Plan: AM Peak



Lane Group	EBL	EBT	EBR	WBL	WBT	WBR	NBL	NBT	NBR	SBL	SBT	SBR
Queue Length 50th (ft)			0			273		191	386	142	0	
Queue Length 95th (ft)			0			#409		246	#657	m181	m0	
Internal Link Dist (ft)		562			281			400				610
Turn Bay Length (ft)									250	250		
Base Capacity (vph)			1611			929		1966	831	557	3539	
Starvation Cap Reductn			0			0		0	0	0	0	
Spillback Cap Reductn			0			0		0	0	0	0	
Storage Cap Reductn			0			0		0	0	0	0	
Reduced v/c Ratio			0.30			0.95		0.54	0.94	0.57	0.50	

Intersection Summary

Area Type: Other
 Cycle Length: 90
 Actuated Cycle Length: 90
 Offset: 0 (0%), Referenced to phase 2:NBT, Start of Green
 Natural Cycle: 80
 Control Type: Actuated-Coordinated
 Maximum v/c Ratio: 0.95
 Intersection Signal Delay: 18.4
 Intersection LOS: B
 Intersection Capacity Utilization 67.7%
 ICU Level of Service C
 Analysis Period (min) 15
 # 95th percentile volume exceeds capacity, queue may be longer.
 Queue shown is maximum after two cycles.
 m Volume for 95th percentile queue is metered by upstream signal.

Splits and Phases: 5: I-26 SB Ramps & Balfour Pkwy



Lanes, Volumes, Timings
6: US 64 & SR 1516 (Francis Rd)

2040 Design Year - Build 6 Lanes

Timing Plan: AM Peak



Lane Group	EBL	EBT	EBR	WBL	WBT	WBR	NBL	NBT	NBR	SBL	SBT	SBR
Lane Configurations												
Volume (vph)	174	1694	500	69	2164	19	441	5	48	13	5	153
Ideal Flow (vphpl)	1900	1900	1900	1900	1900	1900	1900	1900	1900	1900	1900	1900
Grade (%)		-1%			4%			-1%			2%	
Storage Length (ft)	150		0	125		0	150		150	0		150
Storage Lanes	1		1	1		0	1		1	0		1
Taper Length (ft)	100		100	100		100	100		100	100		100
Lane Util. Factor	1.00	0.95	1.00	1.00	0.95	0.95	0.95	0.95	1.00	1.00	1.00	1.00
Frt			0.850		0.999				0.850			0.850
Flt Protected	0.950			0.950			0.950	0.953			0.966	
Satd. Flow (prot)	1778	3557	1591	1734	3465	0	1690	1695	1591	0	1781	1567
Flt Permitted	0.950			0.950			0.950	0.953			0.966	
Satd. Flow (perm)	1778	3557	1591	1734	3465	0	1690	1695	1591	0	1781	1567
Right Turn on Red			No			No			No			No
Satd. Flow (RTOR)												
Link Speed (mph)		45			45			35			35	
Link Distance (ft)		835			622			375			406	
Travel Time (s)		12.7			9.4			7.3			7.9	
Peak Hour Factor	0.90	0.90	0.90	0.90	0.90	0.90	0.90	0.90	0.90	0.90	0.90	0.90
Heavy Vehicles (%)	2%	2%	2%	2%	2%	2%	2%	2%	2%	2%	2%	2%
Adj. Flow (vph)	193	1882	556	77	2404	21	490	6	53	14	6	170
Shared Lane Traffic (%)							49%					
Lane Group Flow (vph)	193	1882	556	77	2425	0	250	246	53	0	20	170
Turn Type	Prot		Perm	Prot			Split		pm+ov	Split		pm+ov
Protected Phases	5	2		1	6		4	4	1	3	3	5
Permitted Phases			2						4			3
Detector Phase	5	2	2	1	6		4	4	1	3	3	5
Switch Phase												
Minimum Initial (s)	7.0	12.0	12.0	7.0	12.0		7.0	7.0	7.0	7.0	7.0	7.0
Minimum Split (s)	13.0	18.0	18.0	13.0	18.0		14.0	14.0	13.0	14.0	14.0	13.0
Total Split (s)	18.0	98.0	98.0	14.0	94.0	0.0	24.0	24.0	14.0	14.0	14.0	18.0
Total Split (%)	12.0%	65.3%	65.3%	9.3%	62.7%	0.0%	16.0%	16.0%	9.3%	9.3%	9.3%	12.0%
Maximum Green (s)	12.4	92.0	92.0	8.6	88.4		17.4	17.4	8.6	7.5	7.5	12.4
Yellow Time (s)	3.2	4.6	4.6	3.0	4.2		3.9	3.9	3.0	3.7	3.7	3.2
All-Red Time (s)	2.4	1.4	1.4	2.4	1.4		2.7	2.7	2.4	2.8	2.8	2.4
Lost Time Adjust (s)	-0.6	-1.0	-1.0	-0.4	-0.6	-2.0	-1.6	-1.6	-0.4	-2.0	-1.5	-0.6
Total Lost Time (s)	5.0	5.0	5.0	5.0	5.0	2.0	5.0	5.0	5.0	4.5	5.0	5.0
Lead/Lag	Lag	Lag	Lag	Lead	Lead		Lag	Lag	Lead	Lead	Lead	Lag
Lead-Lag Optimize?	Yes	Yes	Yes	Yes	Yes		Yes	Yes	Yes	Yes	Yes	Yes
Vehicle Extension (s)	1.0	2.0	2.0	1.0	2.0		1.0	1.0	1.0	1.0	1.0	1.0
Recall Mode	None	C-Max	C-Max	None	C-Max		None	None	None	None	None	None
Act Effct Green (s)	13.0	93.3	93.3	8.7	89.0		24.8	24.8	38.5		8.6	21.2
Actuated g/C Ratio	0.09	0.62	0.62	0.06	0.59		0.17	0.17	0.26		0.06	0.14
v/c Ratio	1.25	0.85	0.56	0.77	1.18		0.89	0.88	0.13		0.20	0.77
Control Delay	202.0	18.6	13.7	111.1	115.8		92.6	90.2	46.7		72.1	83.2
Queue Delay	0.0	0.0	0.0	0.0	0.0		0.0	0.0	0.0		0.0	0.0
Total Delay	202.0	18.6	13.7	111.1	115.8		92.6	90.2	46.7		72.1	83.2
LOS	F	B	B	F	F		F	F	D		E	F
Approach Delay		31.0			115.7			87.1			82.0	

Lanes, Volumes, Timings
6: US 64 & SR 1516 (Francis Rd)

2040 Design Year - Build 6 Lanes

Timing Plan: AM Peak



Lane Group	EBL	EBT	EBR	WBL	WBT	WBR	NBL	NBT	NBR	SBL	SBT	SBR
Approach LOS	C			F			F			F		
Queue Length 50th (ft)	~234	425	189	76	~1491		~298	~290	42		19	156
Queue Length 95th (ft)	#403	542	239	#164	#1614		#495	#486	83		48	240
Internal Link Dist (ft)	755			542			295			326		
Turn Bay Length (ft)	150			125			150		150			150
Base Capacity (vph)	154	2213	989	104	2056		280	280	412		107	222
Starvation Cap Reductn	0	0	0	0	0		0	0	0		0	0
Spillback Cap Reductn	0	0	0	0	0		0	0	0		0	0
Storage Cap Reductn	0	0	0	0	0		0	0	0		0	0
Reduced v/c Ratio	1.25	0.85	0.56	0.74	1.18		0.89	0.88	0.13		0.19	0.77

Intersection Summary

Area Type: Other
 Cycle Length: 150
 Actuated Cycle Length: 150
 Offset: 27 (18%), Referenced to phase 2:EBT and 6:WBT, Start of Green
 Natural Cycle: 200
 Control Type: Actuated-Coordinated
 Maximum v/c Ratio: 1.25
 Intersection Signal Delay: 74.0
 Intersection LOS: E
 Intersection Capacity Utilization 101.6%
 ICU Level of Service G
 Analysis Period (min) 15
 ~ Volume exceeds capacity, queue is theoretically infinite.
 Queue shown is maximum after two cycles.
 # 95th percentile volume exceeds capacity, queue may be longer.
 Queue shown is maximum after two cycles.

Splits and Phases: 6: US 64 & SR 1516 (Francis Rd)



Lanes, Volumes, Timings
7: US 64 & I-26 SB Off-Ramp

2040 Design Year - Build 6 Lanes

Timing Plan: AM Peak

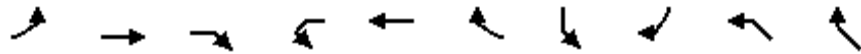

Lane Group	EBL	EBT	EBR	WBL	WBT	WBR	SBL	SBR	NWL	NWR
Lane Configurations		↑↑	↑		↑↑			↑↑		
Volume (vph)	0	1629	366	0	1959	0	0	497	0	0
Ideal Flow (vphpl)	1900	1900	1900	1900	1900	1900	1900	1900	1900	1900
Grade (%)		3%			-3%		-3%		0%	
Storage Length (ft)	0		400	0		0	0	500	0	0
Storage Lanes	0		1	0		0	0	1	0	0
Taper Length (ft)	100		100	100		100	100	100	100	100
Lane Util. Factor	1.00	0.95	1.00	1.00	0.95	1.00	1.00	0.88	1.00	1.00
Frt			0.850					0.850		
Flt Protected										
Satd. Flow (prot)	0	3486	1473	0	3592	0	0	2828	0	0
Flt Permitted										
Satd. Flow (perm)	0	3486	1473	0	3592	0	0	2828	0	0
Right Turn on Red			No			No		No		
Satd. Flow (RTOR)										
Link Speed (mph)		45			45		35		45	
Link Distance (ft)		728			791		804		308	
Travel Time (s)		11.0			12.0		15.7		4.7	
Peak Hour Factor	0.90	0.90	0.90	0.90	0.90	0.90	0.90	0.90	0.90	0.90
Heavy Vehicles (%)	5%	2%	8%	5%	2%	5%	5%	2%	5%	5%
Adj. Flow (vph)	0	1810	407	0	2177	0	0	552	0	0
Shared Lane Traffic (%)										
Lane Group Flow (vph)	0	1810	407	0	2177	0	0	552	0	0
Turn Type			Perm					custom		
Protected Phases		Free			6			4		
Permitted Phases			Free							
Detector Phase					6			4		
Switch Phase										
Minimum Initial (s)					12.0			7.0		
Minimum Split (s)					18.0			13.0		
Total Split (s)	0.0	0.0	0.0	0.0	109.0	0.0	0.0	41.0	0.0	0.0
Total Split (%)	0.0%	0.0%	0.0%	0.0%	72.7%	0.0%	0.0%	27.3%	0.0%	0.0%
Maximum Green (s)					103.2			35.9		
Yellow Time (s)					4.8			4.1		
All-Red Time (s)					1.0			1.0		
Lost Time Adjust (s)	-2.0	0.0	-2.0	-2.0	-0.8	-2.0	-2.0	-0.1	-2.0	-2.0
Total Lost Time (s)	2.0	4.0	2.0	2.0	5.0	2.0	2.0	5.0	2.0	2.0
Lead/Lag										
Lead-Lag Optimize?										
Vehicle Extension (s)					2.0			1.0		
Recall Mode					C-Max			None		
Act Effct Green (s)		150.0	150.0		107.9			32.1		
Actuated g/C Ratio		1.00	1.00		0.72			0.21		
v/c Ratio		0.52	0.28		0.84			0.91		
Control Delay		0.1	0.0		17.3			77.6		
Queue Delay		0.0	0.0		0.0			0.0		
Total Delay		0.1	0.0		17.3			77.6		
LOS		A	A		B			E		
Approach Delay		0.0			17.3					

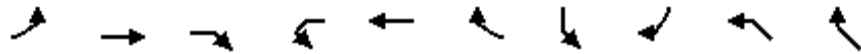

Lane Group	EBL	EBT	EBR	WBL	WBT	WBR	SBL	SBR	NWL	NWR
Approach LOS	A			B						
Queue Length 50th (ft)	0			500			300			
Queue Length 95th (ft)	m0			m460			372			
Internal Link Dist (ft)	648			711			724		228	
Turn Bay Length (ft)	400						500			
Base Capacity (vph)	3486		1473	2584			679			
Starvation Cap Reductn	0			0			0			
Spillback Cap Reductn	0			0			0			
Storage Cap Reductn	0			0			0			
Reduced v/c Ratio	0.52		0.28	0.84			0.81			

Intersection Summary

Area Type: Other

Cycle Length: 150

Actuated Cycle Length: 150

Offset: 0 (0%), Referenced to phase 6:WBT, Start of Green, Master Intersection

Natural Cycle: 75

Control Type: Actuated-Coordinated

Maximum v/c Ratio: 0.91

Intersection Signal Delay: 16.3

Intersection LOS: B

Intersection Capacity Utilization 86.6%

ICU Level of Service E

Analysis Period (min) 15

m Volume for 95th percentile queue is metered by upstream signal.

Splits and Phases: 7: US 64 & I-26 SB Off-Ramp



Lanes, Volumes, Timings
8: US 64 & SR 1634 (Carolina Village Rd)

2040 Design Year - Build 6 Lanes

Timing Plan: AM Peak



Lane Group	EBL	EBT	EBR	WBL	WBT	WBR	NBL	NBT	NBR	SBL	SBT	SBR
Lane Configurations												
Volume (vph)	70	1593	86	243	1982	208	81	5	184	237	5	100
Ideal Flow (vphpl)	1900	1900	1900	1900	1900	1900	1900	1900	1900	1900	1900	1900
Grade (%)		1%			-3%			3%			-1%	
Storage Length (ft)	100		0	100		0	0		0	0		150
Storage Lanes	1		0	1		1	0		0	0		1
Taper Length (ft)	100		100	100		100	100		100	100		100
Lane Util. Factor	1.00	0.95	0.95	1.00	0.95	1.00	1.00	1.00	1.00	1.00	1.00	1.00
Frt		0.992				0.850		0.908				0.850
Flt Protected	0.950			0.950				0.985			0.953	
Satd. Flow (prot)	1761	3493	0	1796	3592	1607	0	1641	0	0	1784	1591
Flt Permitted	0.950			0.950				0.564			0.441	
Satd. Flow (perm)	1761	3493	0	1796	3592	1607	0	940	0	0	826	1591
Right Turn on Red			No			No			No			No
Satd. Flow (RTOR)												
Link Speed (mph)		45			45			30			30	
Link Distance (ft)		560			728			219			359	
Travel Time (s)		8.5			11.0			5.0			8.2	
Peak Hour Factor	0.90	0.90	0.90	0.90	0.90	0.90	0.90	0.90	0.90	0.90	0.90	0.90
Heavy Vehicles (%)	2%	2%	2%	2%	2%	2%	2%	2%	2%	2%	2%	2%
Adj. Flow (vph)	78	1770	96	270	2202	231	90	6	204	263	6	111
Shared Lane Traffic (%)												
Lane Group Flow (vph)	78	1866	0	270	2202	231	0	300	0	0	269	111
Turn Type	Prot			Prot		Perm	Perm			Perm		pm+ov
Protected Phases	5	2		1	6			8			4	5
Permitted Phases						6	8			4		4
Detector Phase	5	2		1	6	6	8	8		4	4	5
Switch Phase												
Minimum Initial (s)	7.0	12.0		7.0	12.0	12.0	7.0	7.0		7.0	7.0	7.0
Minimum Split (s)	13.0	18.0		13.0	19.0	19.0	13.0	13.0		13.0	13.0	13.0
Total Split (s)	13.0	78.0	0.0	24.0	89.0	89.0	48.0	48.0	0.0	48.0	48.0	13.0
Total Split (%)	8.7%	52.0%	0.0%	16.0%	59.3%	59.3%	32.0%	32.0%	0.0%	32.0%	32.0%	8.7%
Maximum Green (s)	7.1	72.4		18.6	82.8	82.8	42.2	42.2		42.1	42.1	7.1
Yellow Time (s)	3.0	4.4		3.0	4.8	4.8	3.4	3.4		3.6	3.6	3.0
All-Red Time (s)	2.9	1.2		2.4	1.4	1.4	2.4	2.4		2.3	2.3	2.9
Lost Time Adjust (s)	-0.9	-0.6	-2.0	-0.4	-1.2	-1.2	-2.0	-0.8	-2.0	-2.0	-0.9	-0.9
Total Lost Time (s)	5.0	5.0	2.0	5.0	5.0	5.0	3.8	5.0	2.0	3.9	5.0	5.0
Lead/Lag	Lag	Lag		Lead	Lead	Lead						Lag
Lead-Lag Optimize?	Yes	Yes		Yes	Yes	Yes						Yes
Vehicle Extension (s)	1.0	2.0		1.0	2.0	2.0	1.0	1.0		1.0	1.0	1.0
Recall Mode	None	C-Max		None	C-Max	C-Max	None	None		None	None	None
Act Effct Green (s)	8.0	73.0		19.0	84.0	84.0		43.0			43.0	56.0
Actuated g/C Ratio	0.05	0.49		0.13	0.56	0.56		0.29			0.29	0.37
v/c Ratio	0.83	1.10		1.19	1.09	0.26		1.12			1.14	0.19
Control Delay	123.7	90.4		160.3	76.5	17.2		137.5			147.1	32.8
Queue Delay	0.0	0.0		0.0	40.6	0.0		0.0			0.0	0.0
Total Delay	123.7	90.4		160.3	117.0	17.2		137.5			147.1	32.8
LOS	F	F		F	F	B		F			F	C
Approach Delay		91.7			112.8			137.5			113.7	

Lanes, Volumes, Timings
 8: US 64 & SR 1634 (Carolina Village Rd)

2040 Design Year - Build 6 Lanes

Timing Plan: AM Peak



Lane Group	EBL	EBT	EBR	WBL	WBT	WBR	NBL	NBT	NBR	SBL	SBT	SBR
Approach LOS		F			F			F			F	
Queue Length 50th (ft)	77	~1084		~318	~1270		99	~335		~306	73	
Queue Length 95th (ft)	#177	#1220		m#429	#1404		m144	#530		#492	121	
Internal Link Dist (ft)		480			648			139			279	
Turn Bay Length (ft)	100			100							150	
Base Capacity (vph)	94	1700		227	2012		900	269		237	594	
Starvation Cap Reductn	0	0		0	157		0	0		0	0	
Spillback Cap Reductn	0	0		0	0		0	0		0	0	
Storage Cap Reductn	0	0		0	0		0	0		0	0	
Reduced v/c Ratio	0.83	1.10		1.19	1.19		0.26	1.12		1.14	0.19	

Intersection Summary

Area Type: Other
 Cycle Length: 150
 Actuated Cycle Length: 150
 Offset: 145 (97%), Referenced to phase 2:EBT and 6:WBT, Start of Green
 Natural Cycle: 180
 Control Type: Actuated-Coordinated
 Maximum v/c Ratio: 1.19
 Intersection Signal Delay: 106.6 Intersection LOS: F
 Intersection Capacity Utilization 106.7% ICU Level of Service G
 Analysis Period (min) 15
 ~ Volume exceeds capacity, queue is theoretically infinite.
 Queue shown is maximum after two cycles.
 # 95th percentile volume exceeds capacity, queue may be longer.
 Queue shown is maximum after two cycles.
 m Volume for 95th percentile queue is metered by upstream signal.

Splits and Phases: 8: US 64 & SR 1634 (Carolina Village Rd)

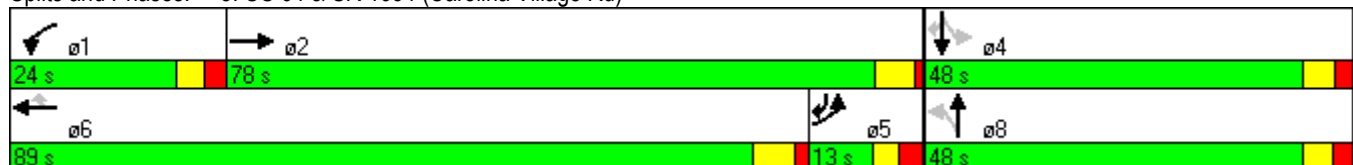

Lanes, Volumes, Timings
 9: SR 1783 (Upward Rd) & I-26 NB On-Ramp

2040 Design Year - Build 6 Lanes

Timing Plan: AM Peak



Lane Group	EBL	EBT	EBR	WBL	WBT	WBR	NBL	NBT	NBR	SBL	SBT	SBR
Lane Configurations	↖↗	↑↑			↑↑		↖	↗	↗			
Volume (vph)	613	566	0	0	715	161	524	0	142	0	0	0
Ideal Flow (vphpl)	1900	1900	1900	1900	1900	1900	1900	1900	1900	1900	1900	1900
Grade (%)		-3%			3%			4%			0%	
Storage Length (ft)	275		0	0		0	250		175	0		0
Storage Lanes	1		0	0		0	1		1	0		0
Taper Length (ft)	100		100	100		100	100		100	100		100
Lane Util. Factor	0.97	0.95	1.00	1.00	0.95	0.95	0.95	0.95	1.00	1.00	1.00	1.00
Frt					0.972				0.850			
Flt Protected	0.950						0.950	0.950				
Satd. Flow (prot)	3291	3592	0	0	3352	0	1648	1648	1552	0	0	0
Flt Permitted	0.950						0.950	0.950				
Satd. Flow (perm)	3291	3592	0	0	3352	0	1648	1648	1552	0	0	0
Right Turn on Red			No			No			No			No
Satd. Flow (RTOR)												
Link Speed (mph)		45			45			35			45	
Link Distance (ft)		630			322			532			658	
Travel Time (s)		9.5			4.9			10.4			10.0	
Peak Hour Factor	0.90	0.90	0.90	0.90	0.90	0.90	0.90	0.90	0.90	0.90	0.90	0.90
Heavy Vehicles (%)	8%	2%	5%	5%	2%	8%	2%	2%	2%	5%	5%	5%
Adj. Flow (vph)	681	629	0	0	794	179	582	0	158	0	0	0
Shared Lane Traffic (%)							50%					
Lane Group Flow (vph)	681	629	0	0	973	0	291	291	158	0	0	0
Turn Type	Prot						Split		Prot			
Protected Phases	5	2			6		8	8	8			
Permitted Phases												
Detector Phase	5	2			6		8	8	8			
Switch Phase												
Minimum Initial (s)	7.0	14.0			14.0		7.0	7.0	7.0			
Minimum Split (s)	14.0	22.0			21.0		19.0	19.0	19.0			
Total Split (s)	27.0	65.0	0.0	0.0	38.0	0.0	25.0	25.0	25.0	0.0	0.0	0.0
Total Split (%)	30.0%	72.2%	0.0%	0.0%	42.2%	0.0%	27.8%	27.8%	27.8%	0.0%	0.0%	0.0%
Maximum Green (s)	20.7	58.8			32.4		18.9	18.9	18.9			
Yellow Time (s)	3.0	5.1			4.6		3.6	3.6	3.6			
All-Red Time (s)	3.3	1.1			1.0		2.5	2.5	2.5			
Lost Time Adjust (s)	-1.3	-1.2	0.0	0.0	-0.6	-2.0	-1.1	-1.1	-1.1	-2.0	0.0	0.0
Total Lost Time (s)	5.0	5.0	4.0	4.0	5.0	2.0	5.0	5.0	5.0	2.0	4.0	4.0
Lead/Lag	Lag				Lead							
Lead-Lag Optimize?	Yes				Yes							
Vehicle Extension (s)	2.0	2.0			2.0		2.0	2.0	2.0			
Minimum Gap (s)	3.0	3.1			3.1		3.0	3.0	3.0			
Time Before Reduce (s)	0.0	15.0			15.0		0.0	0.0	0.0			
Time To Reduce (s)	0.0	45.0			45.0		0.0	0.0	0.0			
Recall Mode	None	C-Max			C-Max		None	None	None			
Act Effct Green (s)	22.0	61.3			34.3		18.7	18.7	18.7			
Actuated g/C Ratio	0.24	0.68			0.38		0.21	0.21	0.21			
v/c Ratio	0.85	0.26			0.76		0.85	0.85	0.49			
Control Delay	32.4	1.8			29.4		57.6	57.6	36.7			
Queue Delay	0.0	0.0			0.0		0.0	0.0	0.0			

Lanes, Volumes, Timings
 9: SR 1783 (Upward Rd) & I-26 NB On-Ramp

2040 Design Year - Build 6 Lanes

Timing Plan: AM Peak



Lane Group	EBL	EBT	EBR	WBL	WBT	WBR	NBL	NBT	NBR	SBL	SBT	SBR
Total Delay	32.4	1.8			29.4		57.6	57.6	36.7			
LOS	C	A			C		E	E	D			
Approach Delay		17.7			29.4			53.1				
Approach LOS		B			C			D				
Queue Length 50th (ft)	202	14			255		165	165	78			
Queue Length 95th (ft)	#283	24			334		#298	#298	139			
Internal Link Dist (ft)		550			242			452			578	
Turn Bay Length (ft)	275						250		175			
Base Capacity (vph)	804	2447			1277		366	366	345			
Starvation Cap Reductn	0	0			0		0	0	0			
Spillback Cap Reductn	0	0			0		0	0	0			
Storage Cap Reductn	0	0			0		0	0	0			
Reduced v/c Ratio	0.85	0.26			0.76		0.80	0.80	0.46			

Intersection Summary

Area Type: Other
 Cycle Length: 90
 Actuated Cycle Length: 90
 Offset: 7 (8%), Referenced to phase 2:EBT and 6:WBT, Start of Green
 Natural Cycle: 60
 Control Type: Actuated-Coordinated
 Maximum v/c Ratio: 0.85
 Intersection Signal Delay: 30.2
 Intersection LOS: C
 Intersection Capacity Utilization 69.4%
 ICU Level of Service C
 Analysis Period (min) 15
 # 95th percentile volume exceeds capacity, queue may be longer.
 Queue shown is maximum after two cycles.

Splits and Phases: 9: SR 1783 (Upward Rd) & I-26 NB On-Ramp

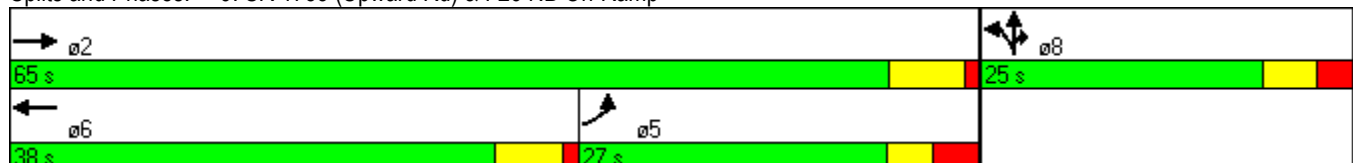

Lanes, Volumes, Timings
 10: SR 1783 (Upward Rd) & I-26 SB Off-Ramp

2040 Design Year - Build 6 Lanes

Timing Plan: AM Peak



Lane Group	EBL	EBT	EBR	WBL	WBT	WBR	NBL	NBT	NBR	SBL	SBT	SBR
Lane Configurations		↑↑↑	↗	↘	↑↑						↖	↗↗
Volume (vph)	0	1021	509	181	1058	0	0	0	0	158	0	785
Ideal Flow (vphpl)	1900	1900	1900	1900	1900	1900	1900	1900	1900	1900	1900	1900
Grade (%)		4%			-4%			0%			5%	
Storage Length (ft)	275		0	150		0	0		0	250		0
Storage Lanes	1		1	1		0	0		0	1		2
Taper Length (ft)	100		100	100		100	100		100	100		100
Lane Util. Factor	1.00	0.91	1.00	1.00	0.95	1.00	1.00	1.00	1.00	1.00	1.00	0.88
Frt		0.850										0.850
Flt Protected				0.950							0.950	
Satd. Flow (prot)	0	4841	1507	1753	3507	0	0	0	0	0	1676	2639
Flt Permitted				0.145							0.950	
Satd. Flow (perm)	0	4841	1507	268	3507	0	0	0	0	0	1676	2639
Right Turn on Red			No			No			No			No
Satd. Flow (RTOR)												
Link Speed (mph)		45			45			45			35	
Link Distance (ft)		549			630			547			651	
Travel Time (s)		8.3			9.5			8.3			12.7	
Peak Hour Factor	0.90	0.90	0.90	0.90	0.90	0.90	0.90	0.90	0.90	0.90	0.90	0.90
Adj. Flow (vph)	0	1134	566	201	1176	0	0	0	0	176	0	872
Shared Lane Traffic (%)												
Lane Group Flow (vph)	0	1134	566	201	1176	0	0	0	0	0	176	872
Turn Type			Perm		pm+pt					Split		Prot
Protected Phases		2		1	6					4	4	4
Permitted Phases			2	6								
Detector Phase		2	2	1	6					4	4	4
Switch Phase												
Minimum Initial (s)		14.0	14.0	7.0	14.0					7.0	7.0	7.0
Minimum Split (s)		20.0	20.0	14.0	21.0					13.0	13.0	13.0
Total Split (s)	0.0	41.0	41.0	14.0	55.0	0.0	0.0	0.0	0.0	35.0	35.0	35.0
Total Split (%)	0.0%	45.6%	45.6%	15.6%	61.1%	0.0%	0.0%	0.0%	0.0%	38.9%	38.9%	38.9%
Maximum Green (s)		35.4	35.4	7.6	48.6					29.1	29.1	29.1
Yellow Time (s)		4.5	4.5	3.0	5.2					3.6	3.6	3.6
All-Red Time (s)		1.1	1.1	3.4	1.2					2.3	2.3	2.3
Lost Time Adjust (s)	-2.0	-0.6	-0.6	-1.4	-1.4	-2.0	0.0	0.0	0.0	-2.0	-0.9	-0.9
Total Lost Time (s)	2.0	5.0	5.0	5.0	5.0	2.0	4.0	4.0	4.0	3.9	5.0	5.0
Lead/Lag		Lag	Lag	Lead								
Lead-Lag Optimize?		Yes	Yes	Yes								
Vehicle Extension (s)		2.0	2.0	2.0	2.0					2.0	2.0	2.0
Minimum Gap (s)		3.1	3.1	3.0	3.1					3.0	3.0	3.0
Time Before Reduce (s)		15.0	15.0	0.0	15.0					0.0	0.0	0.0
Time To Reduce (s)		45.0	45.0	0.0	45.0					0.0	0.0	0.0
Recall Mode		C-Max	C-Max	None	C-Max					None	None	None
Act Effct Green (s)		36.1	36.1	50.0	50.0						30.0	30.0
Actuated g/C Ratio		0.40	0.40	0.56	0.56						0.33	0.33
v/c Ratio		0.58	0.94	0.68	0.60						0.31	0.99
Control Delay		22.6	51.5	19.2	3.7						24.3	59.6
Queue Delay		0.0	0.0	0.0	0.0						0.0	0.0
Total Delay		22.6	51.5	19.2	3.7						24.3	59.6

Lanes, Volumes, Timings
 10: SR 1783 (Upward Rd) & I-26 SB Off-Ramp

2040 Design Year - Build 6 Lanes

Timing Plan: AM Peak



Lane Group	EBL	EBT	EBR	WBL	WBT	WBR	NBL	NBT	NBR	SBL	SBT	SBR
LOS		C	D	B	A						C	E
Approach Delay		32.2			5.9						53.7	
Approach LOS		C			A						D	
Queue Length 50th (ft)		180	302	22	48						74	277
Queue Length 95th (ft)		225	#516	m50	66						128	#421
Internal Link Dist (ft)		469			550			467			571	
Turn Bay Length (ft)				150								
Base Capacity (vph)		1943	605	297	1948						559	880
Starvation Cap Reductn		0	0	0	0						0	0
Spillback Cap Reductn		0	0	0	0						0	0
Storage Cap Reductn		0	0	0	0						0	0
Reduced v/c Ratio		0.58	0.94	0.68	0.60						0.31	0.99

Intersection Summary

Area Type: Other
 Cycle Length: 90
 Actuated Cycle Length: 90
 Offset: 12 (13%), Referenced to phase 2:EBT and 6:WBTL, Start of Green
 Natural Cycle: 90
 Control Type: Actuated-Coordinated
 Maximum v/c Ratio: 0.99
 Intersection Signal Delay: 28.9
 Intersection LOS: C
 Intersection Capacity Utilization 69.4%
 ICU Level of Service C
 Analysis Period (min) 15
 # 95th percentile volume exceeds capacity, queue may be longer.
 Queue shown is maximum after two cycles.
 m Volume for 95th percentile queue is metered by upstream signal.

Splits and Phases: 10: SR 1783 (Upward Rd) & I-26 SB Off-Ramp

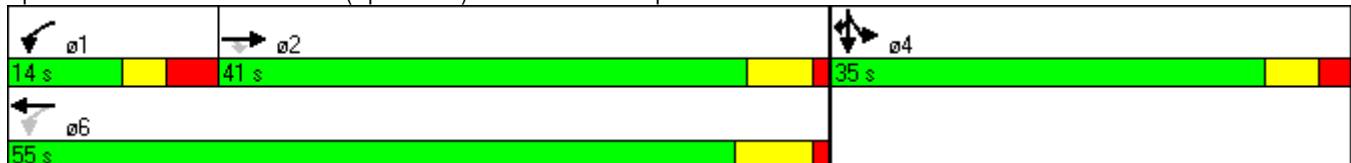

Lanes, Volumes, Timings
1: NC 146 (Long Shoals Rd) & I-26 NB On-Ramp

2040 Design Year - Build 6 Lanes

Timing Plan: PM Peak

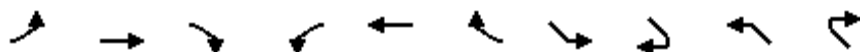

Lane Group	EBL	EBT	EBR2	WBL	WBT	WBR2	SEL	SER2	NWL	NWR2
Lane Configurations										
Volume (vph)	415	1142	386	454	864	829	859	325	380	590
Ideal Flow (vphpl)	1900	1900	1900	1900	1900	1900	1900	1900	1900	1900
Grade (%)		3%			-7%					
Storage Length (ft)	450			350			0		675	
Storage Lanes	1			2			2		1	
Taper Length (ft)	100			100			100		100	
Lane Util. Factor	0.97	0.95	1.00	0.97	0.95	1.00	0.97	1.00	0.97	1.00
Frt			0.850			0.850		0.850		0.850
Flt Protected	0.950			0.950			0.950		0.950	
Satd. Flow (prot)	3224	3452	1487	3387	3663	1562	3519	1607	3434	1599
Flt Permitted	0.950			0.950			0.950		0.950	
Satd. Flow (perm)	3224	3452	1487	3387	3663	1562	3519	1607	3434	1599
Right Turn on Red			No			No		No		No
Satd. Flow (RTOR)										
Link Speed (mph)		45			45					
Link Distance (ft)		1009			964					
Travel Time (s)		15.3			14.6					
Peak Hour Factor	0.90	0.90	0.90	0.90	0.90	0.90	0.90	0.90	0.90	0.90
Heavy Vehicles (%)	7%	3%	7%	7%	2%	7%	2%	3%	3%	2%
Adj. Flow (vph)	461	1269	429	504	960	921	954	361	422	656
Shared Lane Traffic (%)										
Lane Group Flow (vph)	461	1269	429	504	960	921	954	361	422	656
Turn Type	Prot		Free	Prot		Free	Prot	custom	Prot	Free
Protected Phases	5	2		1	6		4		8	
Permitted Phases			Free			Free		4		Free
Detector Phase	5	2		1	6		4	4	8	
Switch Phase										
Minimum Initial (s)	7.0	12.0		7.0	12.0		7.0	7.0	7.0	
Minimum Split (s)	16.0	20.0		15.0	21.0		16.0	16.0	15.0	
Total Split (s)	24.0	47.0	0.0	19.0	42.0	0.0	34.0	34.0	34.0	0.0
Total Split (%)	24.0%	47.0%	0.0%	19.0%	42.0%	0.0%	34.0%	34.0%	34.0%	0.0%
Maximum Green (s)	15.8	39.5		11.3	33.0		25.9	25.9	26.0	
Yellow Time (s)	3.4	4.3		4.0	5.2		3.8	3.8	3.7	
All-Red Time (s)	4.8	3.2		3.7	3.8		4.3	4.3	4.3	
Lost Time Adjust (s)	-3.2	-2.5	-2.5	-2.7	-4.0	-4.0	-3.1	-3.1	-3.0	0.0
Total Lost Time (s)	5.0	5.0	1.5	5.0	5.0	0.0	5.0	5.0	5.0	4.0
Lead/Lag	Lead	Lag		Lead	Lag					
Lead-Lag Optimize?	Yes	Yes		Yes	Yes					
Vehicle Extension (s)	2.0	6.0		2.0	6.0		2.0	2.0	2.0	
Minimum Gap (s)	3.0	3.0		3.0	3.0		3.0	3.0	3.0	
Time Before Reduce (s)	0.0	15.0		0.0	15.0		0.0	0.0	0.0	
Time To Reduce (s)	0.0	30.0		0.0	30.0		0.0	0.0	0.0	
Recall Mode	None	C-Max		None	C-Max		None	None	None	
Act Effct Green (s)	18.6	42.0	100.0	14.0	37.4	100.0	29.0	29.0	29.0	100.0
Actuated g/C Ratio	0.19	0.42	1.00	0.14	0.37	1.00	0.29	0.29	0.29	1.00
v/c Ratio	0.77	0.88	0.29	1.06	0.70	0.59	0.93	0.77	0.42	0.41
Control Delay	48.3	34.9	0.5	101.4	30.0	1.6	51.6	45.5	30.3	0.8
Queue Delay	0.0	0.0	0.0	0.0	0.0	0.0	0.0	0.0	0.0	0.0

Lanes, Volumes, Timings
 1: NC 146 (Long Shoals Rd) & I-26 NB On-Ramp

2040 Design Year - Build 6 Lanes

Timing Plan: PM Peak

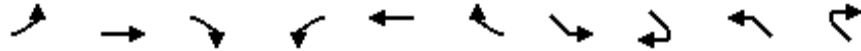

Lane Group	EBL	EBT	EBR2	WBL	WBT	WBR2	SEL	SER2	NWL	NWR2
Total Delay	48.3	34.9	0.5	101.4	30.0	1.6	51.6	45.5	30.3	0.8
LOS	D	C	A	F	C	A	D	D	C	A
Approach Delay	30.9			34.1						
Approach LOS	C			C						
Queue Length 50th (ft)	144	382	0	~183	271	0	304	210	111	0
Queue Length 95th (ft)	200	#485	0	#286	344	0	#428	#348	156	0
Internal Link Dist (ft)	929			884						
Turn Bay Length (ft)	450		300	350		300		425	675	575
Base Capacity (vph)	613	1450	1487	474	1371	1562	1021	466	996	1599
Starvation Cap Reductn	0	0	0	0	0	0	0	0	0	0
Spillback Cap Reductn	0	0	0	0	0	0	0	0	0	0
Storage Cap Reductn	0	0	0	0	0	0	0	0	0	0
Reduced v/c Ratio	0.75	0.88	0.29	1.06	0.70	0.59	0.93	0.77	0.42	0.41

Intersection Summary

Area Type: Other
 Cycle Length: 100
 Actuated Cycle Length: 100
 Offset: 0 (0%), Referenced to phase 2:EBT and 6:WBT, Start of Green
 Natural Cycle: 90
 Control Type: Actuated-Coordinated
 Maximum v/c Ratio: 1.06
 Intersection Signal Delay: 32.7
 Intersection LOS: C
 Intersection Capacity Utilization 81.5%
 ICU Level of Service D
 Analysis Period (min) 15
 ~ Volume exceeds capacity, queue is theoretically infinite.
 Queue shown is maximum after two cycles.
 # 95th percentile volume exceeds capacity, queue may be longer.
 Queue shown is maximum after two cycles.

Splits and Phases: 1: NC 146 (Long Shoals Rd) & I-26 NB On-Ramp

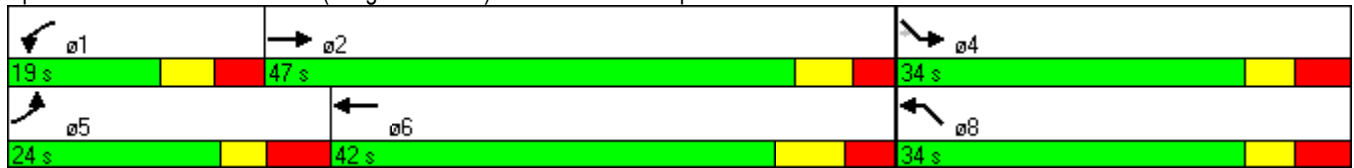

Lanes, Volumes, Timings
 2: I-26 NB On-Ramp & US 25 (Asheville Highway)

2040 Design Year - Build 6 Lanes

Timing Plan: PM Peak



Lane Group	EBL	EBT	EBR	WBL	WBT	WBR	NBL	NBT	NBR	SBL	SBT	SBR
Lane Configurations				↙		↗↗	↙	↗↗			↗↗	↙
Volume (vph)	0	0	0	262	0	616	931	1405	0	0	1384	269
Ideal Flow (vphpl)	1900	1900	1900	1900	1900	1900	1900	1900	1900	1900	1900	1900
Grade (%)		0%			2%			-1%			2%	
Storage Length (ft)	0		0	0		150	0		0	0		300
Storage Lanes	0		0	1		2	1		0	0		1
Taper Length (ft)	100		100	100		100	100		100	100		100
Lane Util. Factor	1.00	1.00	1.00	1.00	1.00	0.88	1.00	0.95	1.00	1.00	0.95	1.00
Frt						0.850						0.850
Flt Protected				0.950			0.950					
Satd. Flow (prot)	0	0	0	1735	0	2706	1680	3489	0	0	3436	1480
Flt Permitted				0.950			0.950					
Satd. Flow (perm)	0	0	0	1735	0	2706	1680	3489	0	0	3436	1480
Right Turn on Red			No			No			No			No
Satd. Flow (RTOR)												
Link Speed (mph)		45			35			45			45	
Link Distance (ft)		533			612			601			596	
Travel Time (s)		8.1			11.9			9.1			9.0	
Peak Hour Factor	0.90	0.90	0.90	0.90	0.90	0.90	0.90	0.90	0.90	0.90	0.90	0.90
Heavy Vehicles (%)	5%	5%	5%	3%	5%	4%	8%	4%	5%	5%	4%	8%
Adj. Flow (vph)	0	0	0	291	0	684	1034	1561	0	0	1538	299
Shared Lane Traffic (%)												
Lane Group Flow (vph)	0	0	0	291	0	684	1034	1561	0	0	1538	299
Turn Type				Prot		custom	Prot					Free
Protected Phases				4			5	2			6	
Permitted Phases						4						Free
Detector Phase				4		4	5	2			6	
Switch Phase												
Minimum Initial (s)				7.0		7.0	7.0	12.0			12.0	
Minimum Split (s)				13.0		13.0	14.0	19.0			18.0	
Total Split (s)	0.0	0.0	0.0	20.0	0.0	20.0	50.0	90.0	0.0	0.0	40.0	0.0
Total Split (%)	0.0%	0.0%	0.0%	18.2%	0.0%	18.2%	45.5%	81.8%	0.0%	0.0%	36.4%	0.0%
Maximum Green (s)				14.0		14.0	43.6	83.9			34.7	
Yellow Time (s)				3.7		3.7	3.0	4.6			4.3	
All-Red Time (s)				2.3		2.3	3.4	1.5			1.0	
Lost Time Adjust (s)	0.0	0.0	-2.0	-2.0	0.0	-2.0	-1.4	-1.1	0.0	-2.0	-0.3	0.0
Total Lost Time (s)	4.0	4.0	2.0	4.0	4.0	4.0	5.0	5.0	4.0	2.0	5.0	4.0
Lead/Lag							Lag				Lead	
Lead-Lag Optimize?							Yes				Yes	
Vehicle Extension (s)				2.0		2.0	2.0	8.0			8.0	
Minimum Gap (s)				3.0		3.0	3.0	5.5			5.5	
Time Before Reduce (s)				0.0		0.0	0.0	15.0			15.0	
Time To Reduce (s)				0.0		0.0	0.0	50.0			50.0	
Recall Mode				None		None	None	C-Max			C-Max	
Act Effct Green (s)				16.0		16.0	45.0	85.0			35.0	110.0
Actuated g/C Ratio				0.15		0.15	0.41	0.77			0.32	1.00
v/c Ratio				1.15		1.74	1.51	0.58			1.41	0.20
Control Delay				147.6		371.9	251.8	7.9			220.0	0.3
Queue Delay				0.0		0.0	4.9	0.7			0.0	0.0

Lanes, Volumes, Timings
 2: I-26 NB On-Ramp & US 25 (Asheville Highway)

2040 Design Year - Build 6 Lanes

Timing Plan: PM Peak



Lane Group	EBL	EBT	EBR	WBL	WBT	WBR	NBL	NBT	NBR	SBL	SBT	SBR
Total Delay				147.6		371.9	256.8	8.6			220.0	0.3
LOS				F		F	F	A			F	A
Approach Delay								107.5			184.2	
Approach LOS								F			F	
Queue Length 50th (ft)				~243		~407	~997	185			~768	0
Queue Length 95th (ft)				#414		#535	m#562	m131			#906	0
Internal Link Dist (ft)		453			532			521			516	
Turn Bay Length (ft)						150						300
Base Capacity (vph)				252		394	687	2696			1093	1480
Starvation Cap Reductn				0		0	5	721			0	0
Spillback Cap Reductn				0		0	0	0			0	0
Storage Cap Reductn				0		0	0	0			0	0
Reduced v/c Ratio				1.15		1.74	1.52	0.79			1.41	0.20

Intersection Summary

Area Type: Other
 Cycle Length: 110
 Actuated Cycle Length: 110
 Offset: 66 (60%), Referenced to phase 2:NBT and 6:SBT, Start of Green
 Natural Cycle: 200
 Control Type: Actuated-Coordinated
 Maximum v/c Ratio: 1.74
 Intersection Signal Delay: 169.2
 Intersection LOS: F
 Intersection Capacity Utilization 116.0%
 ICU Level of Service H
 Analysis Period (min) 15
 ~ Volume exceeds capacity, queue is theoretically infinite.
 Queue shown is maximum after two cycles.
 # 95th percentile volume exceeds capacity, queue may be longer.
 Queue shown is maximum after two cycles.
 m Volume for 95th percentile queue is metered by upstream signal.

Splits and Phases: 2: I-26 NB On-Ramp & US 25 (Asheville Highway)

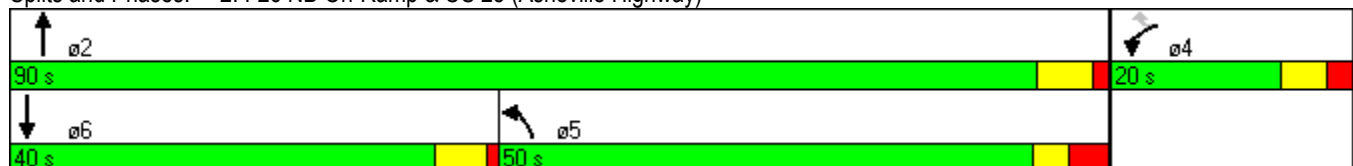

Lanes, Volumes, Timings
3: I-26 SB Off-Ramp & US 25 (Asheville Highway)

2040 Design Year - Build 6 Lanes

Timing Plan: PM Peak



Lane Group	EBL	EBT	EBR	WBL	WBT	WBR	NBL	NBT	NBR	SBL	SBT	SBR
Lane Configurations												
Volume (vph)	273	0	748	0	0	0	0	2063	264	490	1156	0
Ideal Flow (vphpl)	1900	1900	1900	1900	1900	1900	1900	1900	1900	1900	1900	1900
Grade (%)		3%			0%			4%			1%	
Storage Length (ft)	0		100	0		0	0		500	0		0
Storage Lanes	1		1	0		0	0		1	1		0
Taper Length (ft)	100		100	100		100	100		100	100		100
Lane Util. Factor	1.00	1.00	1.00	1.00	1.00	1.00	1.00	0.95	1.00	1.00	0.95	1.00
Frt			0.850						0.850			
Flt Protected	0.950									0.950		
Satd. Flow (prot)	1710	0	1544	0	0	0	0	3435	1465	1663	3487	0
Flt Permitted	0.950									0.950		
Satd. Flow (perm)	1710	0	1544	0	0	0	0	3435	1465	1663	3487	0
Right Turn on Red			Yes			No			No			No
Satd. Flow (RTOR)			77									
Link Speed (mph)		35			45			45			45	
Link Distance (ft)		471			598			795			601	
Travel Time (s)		9.2			9.1			12.0			9.1	
Peak Hour Factor	0.90	0.90	0.90	0.90	0.90	0.90	0.90	0.90	0.90	0.90	0.90	0.90
Heavy Vehicles (%)	4%	5%	3%	5%	5%	5%	5%	3%	8%	8%	3%	5%
Adj. Flow (vph)	303	0	831	0	0	0	0	2292	293	544	1284	0
Shared Lane Traffic (%)												
Lane Group Flow (vph)	303	0	831	0	0	0	0	2292	293	544	1284	0
Turn Type	Prot		custom						Free	Prot		
Protected Phases	4		4					2		1	6	
Permitted Phases									Free			
Detector Phase	4		4					2		1	6	
Switch Phase												
Minimum Initial (s)	7.0		7.0					12.0		7.0	12.0	
Minimum Split (s)	14.0		14.0					19.0		14.0	19.0	
Total Split (s)	35.0	0.0	35.0	0.0	0.0	0.0	0.0	53.0	0.0	22.0	75.0	0.0
Total Split (%)	31.8%	0.0%	31.8%	0.0%	0.0%	0.0%	0.0%	48.2%	0.0%	20.0%	68.2%	0.0%
Maximum Green (s)	29.0		29.0					47.3		15.5	69.3	
Yellow Time (s)	4.0		4.0					4.7		4.0	4.7	
All-Red Time (s)	2.0		2.0					1.0		2.5	1.0	
Lost Time Adjust (s)	-1.0	-2.0	-1.0	-2.0	-2.0	-2.0	-2.0	-0.7	-0.7	-1.5	-1.7	-2.0
Total Lost Time (s)	5.0	2.0	5.0	2.0	2.0	2.0	2.0	5.0	3.3	5.0	4.0	2.0
Lead/Lag								Lead		Lag		
Lead-Lag Optimize?								Yes		Yes		
Vehicle Extension (s)	2.0		2.0					8.0		2.0	8.0	
Minimum Gap (s)	3.0		3.0					5.5		3.0	5.5	
Time Before Reduce (s)	0.0		0.0					15.0		0.0	15.0	
Time To Reduce (s)	0.0		0.0					50.0		0.0	50.0	
Recall Mode	None		None					C-Max		None	C-Max	
Act Effct Green (s)	30.0		30.0					48.0	110.0	17.0	71.0	
Actuated g/C Ratio	0.27		0.27					0.44	1.00	0.15	0.65	
v/c Ratio	0.65		1.74					1.53	0.20	2.12	0.57	
Control Delay	43.0		368.3					268.3	0.3	533.6	29.4	
Queue Delay	1.1		0.0					3.2	0.0	0.0	2.0	

Lanes, Volumes, Timings
 3: I-26 SB Off-Ramp & US 25 (Asheville Highway)

2040 Design Year - Build 6 Lanes

Timing Plan: PM Peak



Lane Group	EBL	EBT	EBR	WBL	WBT	WBR	NBL	NBT	NBR	SBL	SBT	SBR
Total Delay	44.1		368.3					271.5	0.3	533.6	31.4	
LOS	D		F					F	A	F	C	
Approach Delay								240.8			180.8	
Approach LOS								F			F	
Queue Length 50th (ft)	189		~840					~1195	0	~619	434	
Queue Length 95th (ft)	286		#1081					#1333	0	m#403	m319	
Internal Link Dist (ft)		391			518			715				521
Turn Bay Length (ft)			100						500			
Base Capacity (vph)	466		477					1499	1465	257	2251	
Starvation Cap Reductn	0		0					0	0	0	774	
Spillback Cap Reductn	45		0					7	0	0	0	
Storage Cap Reductn	0		0					0	0	0	0	
Reduced v/c Ratio	0.72		1.74					1.54	0.20	2.12	0.87	

Intersection Summary

Area Type: Other
 Cycle Length: 110
 Actuated Cycle Length: 110
 Offset: 0 (0%), Referenced to phase 2:NBT and 6:SBT, Start of Green
 Natural Cycle: 220
 Control Type: Actuated-Coordinated
 Maximum v/c Ratio: 2.12
 Intersection Signal Delay: 229.4
 Intersection LOS: F
 Intersection Capacity Utilization 116.0%
 ICU Level of Service H
 Analysis Period (min) 15
 ~ Volume exceeds capacity, queue is theoretically infinite.
 Queue shown is maximum after two cycles.
 # 95th percentile volume exceeds capacity, queue may be longer.
 Queue shown is maximum after two cycles.
 m Volume for 95th percentile queue is metered by upstream signal.

Splits and Phases: 3: I-26 SB Off-Ramp & US 25 (Asheville Highway)

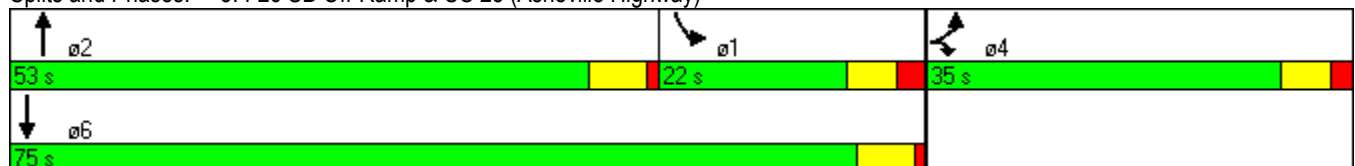

Lanes, Volumes, Timings
4: I-26 NB Ramps & Balfour Pkwy

2040 Design Year - Build 6 Lanes

Timing Plan: PM Peak

Lane Group	EBL	EBT	EBR	WBL	WBT	WBR	NBL	NBT	NBR	SBL	SBT	SBR
Lane Configurations												
Volume (vph)	0	0	703	0	0	268	435	1711	0	0	848	791
Ideal Flow (vphpl)	1900	1900	1900	1900	1900	1900	1900	1900	1900	1900	1900	1900
Storage Length (ft)	0		0	0		0	250		0	0		250
Storage Lanes	0		2	0		1	1		0	0		1
Taper Length (ft)	100		100	100		100	100		100	100		100
Lane Util. Factor	1.00	1.00	0.88	1.00	1.00	1.00	1.00	0.95	1.00	1.00	0.95	1.00
Frt			0.850			0.865						0.850
Flt Protected							0.950					
Satd. Flow (prot)	0	0	2787	0	0	1611	1671	3539	0	0	3539	1495
Flt Permitted							0.950					
Satd. Flow (perm)	0	0	2787	0	0	1611	1671	3539	0	0	3539	1495
Right Turn on Red			No			No			No			No
Satd. Flow (RTOR)												
Link Speed (mph)		25			45			45			45	
Link Distance (ft)		393			429			690			522	
Travel Time (s)		10.7			6.5			10.5			7.9	
Peak Hour Factor	0.90	0.90	0.90	0.90	0.90	0.90	0.90	0.90	0.90	0.90	0.90	0.90
Heavy Vehicles (%)	5%	5%	2%	5%	5%	2%	8%	2%	5%	5%	2%	8%
Adj. Flow (vph)	0	0	781	0	0	298	483	1901	0	0	942	879
Shared Lane Traffic (%)												
Lane Group Flow (vph)	0	0	781	0	0	298	483	1901	0	0	942	879
Turn Type			Over			Free	Prot					Perm
Protected Phases			5				5	Free				6
Permitted Phases						Free						6
Detector Phase			5				5					6
Switch Phase												
Minimum Initial (s)			7.0				7.0				12.0	12.0
Minimum Split (s)			14.0				14.0				19.0	19.0
Total Split (s)	0.0	0.0	30.0	0.0	0.0	0.0	30.0	0.0	0.0	0.0	60.0	60.0
Total Split (%)	0.0%	0.0%	33.3%	0.0%	0.0%	0.0%	33.3%	0.0%	0.0%	0.0%	66.7%	66.7%
Maximum Green (s)			23.0				23.0				53.0	53.0
Yellow Time (s)			5.0				5.0				5.0	5.0
All-Red Time (s)			2.0				2.0				2.0	2.0
Lost Time Adjust (s)	-2.0	-2.0	-2.0	-2.0	-2.0	-2.0	-2.0	-2.0	-2.0	-2.0	-2.0	-2.0
Total Lost Time (s)	2.0	2.0	5.0	2.0	2.0	2.0	5.0	2.0	2.0	2.0	5.0	5.0
Lead/Lag			Lead				Lead				Lag	Lag
Lead-Lag Optimize?			Yes				Yes				Yes	Yes
Vehicle Extension (s)			3.0				3.0				3.0	3.0
Recall Mode			None				None				C-Max	C-Max
Act Effct Green (s)			25.0			90.0	25.0	90.0			55.0	55.0
Actuated g/C Ratio			0.28			1.00	0.28	1.00			0.61	0.61
v/c Ratio			1.01			0.18	1.04	0.54			0.44	0.96
Control Delay			68.5			0.3	71.2	0.3			10.1	40.3
Queue Delay			0.0			0.0	0.0	0.0			0.0	0.0
Total Delay			68.5			0.3	71.2	0.3			10.1	40.3
LOS			E			A	E	A			B	D
Approach Delay								14.7			24.7	
Approach LOS								B			C	

Lanes, Volumes, Timings
 4: I-26 NB Ramps & Balfour Pkwy

2040 Design Year - Build 6 Lanes

Timing Plan: PM Peak



Lane Group	EBL	EBT	EBR	WBL	WBT	WBR	NBL	NBT	NBR	SBL	SBT	SBR
Queue Length 50th (ft)			~256			0	~306	0			136	430
Queue Length 95th (ft)			#392			0	m#416	m0			177	#731
Internal Link Dist (ft)		313			349			610			442	
Turn Bay Length (ft)							250					250
Base Capacity (vph)			774			1611	464	3539			2163	914
Starvation Cap Reductn			0			0	0	0			0	0
Spillback Cap Reductn			0			0	0	0			0	0
Storage Cap Reductn			0			0	0	0			0	0
Reduced v/c Ratio			1.01			0.18	1.04	0.54			0.44	0.96

Intersection Summary

Area Type: Other
 Cycle Length: 90
 Actuated Cycle Length: 90
 Offset: 51 (57%), Referenced to phase 6:SBT, Start of Green
 Natural Cycle: 90
 Control Type: Actuated-Coordinated
 Maximum v/c Ratio: 1.04
 Intersection Signal Delay: 25.3
 Intersection LOS: C
 Intersection Capacity Utilization 81.4%
 ICU Level of Service D
 Analysis Period (min) 15
 ~ Volume exceeds capacity, queue is theoretically infinite.
 Queue shown is maximum after two cycles.
 # 95th percentile volume exceeds capacity, queue may be longer.
 Queue shown is maximum after two cycles.
 m Volume for 95th percentile queue is metered by upstream signal.

Splits and Phases: 4: I-26 NB Ramps & Balfour Pkwy



Lanes, Volumes, Timings
5: I-26 SB Ramps & Balfour Pkwy

2040 Design Year - Build 6 Lanes

Timing Plan: PM Peak

Lane Group	EBL	EBT	EBR	WBL	WBT	WBR	NBL	NBT	NBR	SBL	SBT	SBR
Lane Configurations												
Volume (vph)	0	0	329	0	0	829	0	1317	726	213	1338	0
Ideal Flow (vphpl)	1900	1900	1900	1900	1900	1900	1900	1900	1900	1900	1900	1900
Storage Length (ft)	0		0	0		0	0		250	250		0
Storage Lanes	0		1	0		2	0		1	1		0
Taper Length (ft)	100		100	100		100	100		100	100		100
Lane Util. Factor	1.00	1.00	1.00	1.00	1.00	0.88	1.00	0.95	1.00	1.00	0.95	1.00
Frt			0.865			0.850			0.850			
Flt Protected										0.950		
Satd. Flow (prot)	0	0	1611	0	0	2787	0	3539	1495	1671	3539	0
Flt Permitted										0.950		
Satd. Flow (perm)	0	0	1611	0	0	2787	0	3539	1495	1671	3539	0
Right Turn on Red			No			No			No			No
Satd. Flow (RTOR)												
Link Speed (mph)		45			25			45			45	
Link Distance (ft)		642			361			480			690	
Travel Time (s)		9.7			9.8			7.3			10.5	
Peak Hour Factor	0.90	0.90	0.90	0.90	0.90	0.90	0.90	0.90	0.90	0.90	0.90	0.90
Heavy Vehicles (%)	5%	5%	2%	5%	5%	2%	5%	2%	8%	8%	2%	5%
Adj. Flow (vph)	0	0	366	0	0	921	0	1463	807	237	1487	0
Shared Lane Traffic (%)												
Lane Group Flow (vph)	0	0	366	0	0	921	0	1463	807	237	1487	0
Turn Type			Free			Over			Perm	Prot		
Protected Phases						1		2		1	Free	
Permitted Phases			Free						2			
Detector Phase						1		2	2	1		
Switch Phase												
Minimum Initial (s)						7.0		12.0	12.0	7.0		
Minimum Split (s)						14.0		19.0	19.0	14.0		
Total Split (s)	0.0	0.0	0.0	0.0	0.0	35.0	0.0	55.0	55.0	35.0	0.0	0.0
Total Split (%)	0.0%	0.0%	0.0%	0.0%	0.0%	38.9%	0.0%	61.1%	61.1%	38.9%	0.0%	0.0%
Maximum Green (s)						28.0		48.0	48.0	28.0		
Yellow Time (s)						5.0		5.0	5.0	5.0		
All-Red Time (s)						2.0		2.0	2.0	2.0		
Lost Time Adjust (s)	-2.0	-2.0	-2.0	-2.0	-2.0	-2.0	-2.0	-2.0	-2.0	-2.0	-2.0	-2.0
Total Lost Time (s)	2.0	2.0	2.0	2.0	2.0	5.0	2.0	5.0	5.0	5.0	2.0	2.0
Lead/Lag						Lead		Lag	Lag	Lead		
Lead-Lag Optimize?						Yes		Yes	Yes	Yes		
Vehicle Extension (s)						3.0		3.0	3.0	3.0		
Recall Mode						None		C-Max	C-Max	None		
Act Effct Green (s)			90.0			30.0		50.0	50.0	30.0	90.0	
Actuated g/C Ratio			1.00			0.33		0.56	0.56	0.33	1.00	
v/c Ratio			0.23			0.99		0.74	0.97	0.43	0.42	
Control Delay			0.3			58.8		18.1	46.2	18.6	0.3	
Queue Delay			0.0			0.0		0.0	0.0	0.0	0.0	
Total Delay			0.3			58.8		18.1	46.2	18.6	0.3	
LOS			A			E		B	D	B	A	
Approach Delay								28.1			2.8	
Approach LOS								C			A	

Lanes, Volumes, Timings
5: I-26 SB Ramps & Balfour Pkwy

2040 Design Year - Build 6 Lanes

Timing Plan: PM Peak



Lane Group	EBL	EBT	EBR	WBL	WBT	WBR	NBL	NBT	NBR	SBL	SBT	SBR
Queue Length 50th (ft)			0			293		310	414	96	0	
Queue Length 95th (ft)			0			#440		395	#690	m121	m0	
Internal Link Dist (ft)		562			281			400				610
Turn Bay Length (ft)									250	250		
Base Capacity (vph)			1611			929		1966	831	557	3539	
Starvation Cap Reductn			0			0		0	0	0	0	
Spillback Cap Reductn			0			0		0	0	0	0	
Storage Cap Reductn			0			0		0	0	0	0	
Reduced v/c Ratio			0.23			0.99		0.74	0.97	0.43	0.42	

Intersection Summary

Area Type: Other
 Cycle Length: 90
 Actuated Cycle Length: 90
 Offset: 0 (0%), Referenced to phase 2:NBT, Start of Green
 Natural Cycle: 90
 Control Type: Actuated-Coordinated
 Maximum v/c Ratio: 0.99
 Intersection Signal Delay: 23.3
 Intersection LOS: C
 Intersection Capacity Utilization 73.7%
 ICU Level of Service D
 Analysis Period (min) 15
 # 95th percentile volume exceeds capacity, queue may be longer.
 Queue shown is maximum after two cycles.
 m Volume for 95th percentile queue is metered by upstream signal.

Splits and Phases: 5: I-26 SB Ramps & Balfour Pkwy



Lanes, Volumes, Timings
6: US 64 & SR 1516 (Francis Rd)

2040 Design Year - Build 6 Lanes

Timing Plan: PM Peak



Lane Group	EBL	EBT	EBR	WBL	WBT	WBR	NBL	NBT	NBR	SBL	SBT	SBR
Lane Configurations												
Volume (vph)	153	2163	442	47	1694	13	501	5	69	19	5	174
Ideal Flow (vphpl)	1900	1900	1900	1900	1900	1900	1900	1900	1900	1900	1900	1900
Grade (%)		-1%			4%			-1%			2%	
Storage Length (ft)	150		0	125		0	150		150	0		150
Storage Lanes	1		1	1		0	1		1	0		1
Taper Length (ft)	100		100	100		100	100		100	100		100
Lane Util. Factor	1.00	0.95	1.00	1.00	0.95	0.95	0.95	0.95	1.00	1.00	1.00	1.00
Ped Bike Factor	0.94											
Frt			0.850		0.999				0.850			0.850
Flt Protected	0.950			0.950			0.950	0.953			0.963	
Satd. Flow (prot)	1778	3557	1591	1734	3465	0	1690	1695	1591	0	1776	1567
Flt Permitted	0.950			0.950			0.950	0.953			0.963	
Satd. Flow (perm)	1663	3557	1591	1734	3465	0	1690	1695	1591	0	1776	1567
Right Turn on Red			No			No			No			No
Satd. Flow (RTOR)												
Link Speed (mph)		45			45			35			35	
Link Distance (ft)		836			622			375			406	
Travel Time (s)		12.7			9.4			7.3			7.9	
Confl. Peds. (#/hr)	1700											
Peak Hour Factor	0.90	0.90	0.90	0.90	0.90	0.90	0.90	0.90	0.90	0.90	0.90	0.90
Heavy Vehicles (%)	2%	2%	2%	2%	2%	2%	2%	2%	2%	2%	2%	2%
Adj. Flow (vph)	170	2403	491	52	1882	14	557	6	77	21	6	193
Shared Lane Traffic (%)							49%					
Lane Group Flow (vph)	170	2403	491	52	1896	0	284	279	77	0	27	193
Turn Type	Prot		Perm	Prot			Split		pm+ov	Split		pm+ov
Protected Phases	5	2		1	6		4	4	1	3	3	5
Permitted Phases			2						4			3
Detector Phase	5	2	2	1	6		4	4	1	3	3	5
Switch Phase												
Minimum Initial (s)	7.0	12.0	12.0	7.0	12.0		7.0	7.0	7.0	7.0	7.0	7.0
Minimum Split (s)	13.0	18.0	18.0	13.0	18.0		14.0	14.0	13.0	14.0	14.0	13.0
Total Split (s)	21.0	112.0	112.0	13.0	104.0	0.0	31.0	31.0	13.0	14.0	14.0	21.0
Total Split (%)	12.4%	65.9%	65.9%	7.6%	61.2%	0.0%	18.2%	18.2%	7.6%	8.2%	8.2%	12.4%
Maximum Green (s)	15.4	106.0	106.0	7.6	98.4		24.4	24.4	7.6	7.5	7.5	15.4
Yellow Time (s)	3.2	4.6	4.6	3.0	4.2		3.9	3.9	3.0	3.7	3.7	3.2
All-Red Time (s)	2.4	1.4	1.4	2.4	1.4		2.7	2.7	2.4	2.8	2.8	2.4
Lost Time Adjust (s)	-0.6	-1.0	-1.0	-0.4	-0.6	-2.0	-1.6	-1.6	-0.4	-2.0	-1.5	-0.6
Total Lost Time (s)	5.0	5.0	5.0	5.0	5.0	2.0	5.0	5.0	5.0	4.5	5.0	5.0
Lead/Lag	Lead	Lag	Lag	Lead	Lag		Lag	Lag	Lead	Lead	Lead	Lead
Lead-Lag Optimize?	Yes	Yes	Yes	Yes	Yes		Yes	Yes	Yes	Yes	Yes	Yes
Vehicle Extension (s)	1.0	2.0	2.0	1.0	2.0		1.0	1.0	1.0	1.0	1.0	1.0
Recall Mode	None	C-Max	C-Max	None	C-Max		None	None	None	None	None	None
Act Effct Green (s)	16.0	107.2	107.2	7.8	99.0		31.7	31.7	44.5		8.7	21.3
Actuated g/C Ratio	0.09	0.63	0.63	0.05	0.58		0.19	0.19	0.26		0.05	0.13
v/c Ratio	1.02	1.07	0.49	0.65	0.94		0.90	0.88	0.18		0.30	0.98
Control Delay	150.6	63.3	14.2	113.7	43.1		96.3	93.6	52.3		86.5	124.0
Queue Delay	0.0	0.0	0.0	0.0	0.0		0.0	0.0	0.0		0.0	0.0
Total Delay	150.6	63.3	14.2	113.7	43.1		96.3	93.6	52.3		86.5	124.0

Lanes, Volumes, Timings
6: US 64 & SR 1516 (Francis Rd)

2040 Design Year - Build 6 Lanes
Timing Plan: PM Peak



Lane Group	EBL	EBT	EBR	WBL	WBT	WBR	NBL	NBT	NBR	SBL	SBT	SBR
LOS	F	E	B	F	D		F	F	D		F	F
Approach Delay		60.3			45.0			89.8			119.4	
Approach LOS		E			D			F			F	
Queue Length 50th (ft)	~202	~1551	171	58	994		~369	~356	70		30	158
Queue Length 95th (ft)	#371	#1668	263	#127	1128		#587	#571	122		66	#282
Internal Link Dist (ft)		756			542			295			326	
Turn Bay Length (ft)	150			125			150		150			150
Base Capacity (vph)	167	2243	1003	82	2018		315	316	419		94	196
Starvation Cap Reductn	0	0	0	0	0		0	0	0		0	0
Spillback Cap Reductn	0	0	0	0	0		0	0	0		0	0
Storage Cap Reductn	0	0	0	0	0		0	0	0		0	0
Reduced v/c Ratio	1.02	1.07	0.49	0.63	0.94		0.90	0.88	0.18		0.29	0.98

Intersection Summary

Area Type: Other
 Cycle Length: 170
 Actuated Cycle Length: 170
 Offset: 33 (19%), Referenced to phase 2:EBT and 6:WBT, Start of Green
 Natural Cycle: 220
 Control Type: Actuated-Coordinated
 Maximum v/c Ratio: 1.07
 Intersection Signal Delay: 60.7
 Intersection LOS: E
 Intersection Capacity Utilization 98.8%
 ICU Level of Service F
 Analysis Period (min) 15
 ~ Volume exceeds capacity, queue is theoretically infinite.
 Queue shown is maximum after two cycles.
 # 95th percentile volume exceeds capacity, queue may be longer.
 Queue shown is maximum after two cycles.

Splits and Phases: 6: US 64 & SR 1516 (Francis Rd)

ø1	ø2	ø3	ø4
13 s	112 s	14 s	31 s
ø5	ø6		
21 s	104 s		

Lanes, Volumes, Timings
7: US 64 & I-26 SB Off-Ramp

2040 Design Year - Build 6 Lanes

Timing Plan: PM Peak

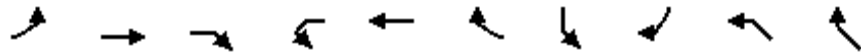

Lane Group	EBL	EBT	EBR	WBL	WBT	WBR	SBL	SBR	NWL	NWR
Lane Configurations		↑↑	↗		↑↑			↖↖		
Volume (vph)	0	2087	369	0	1602	0	0	393	0	0
Ideal Flow (vphpl)	1900	1900	1900	1900	1900	1900	1900	1900	1900	1900
Grade (%)		3%			-3%		-3%		0%	
Storage Length (ft)	0		0	0		0	0	500	0	0
Storage Lanes	0		1	0		0	0	1	0	0
Taper Length (ft)	100		100	100		100	100	100	100	100
Lane Util. Factor	1.00	0.95	1.00	1.00	0.95	1.00	1.00	0.88	1.00	1.00
Frt			0.850					0.850		
Flt Protected										
Satd. Flow (prot)	0	3486	1473	0	3592	0	0	2828	0	0
Flt Permitted										
Satd. Flow (perm)	0	3486	1473	0	3592	0	0	2828	0	0
Right Turn on Red			No			No		No		
Satd. Flow (RTOR)										
Link Speed (mph)		45			45		35		45	
Link Distance (ft)		728			745		807		350	
Travel Time (s)		11.0			11.3		15.7		5.3	
Peak Hour Factor	0.90	0.90	0.90	0.90	0.90	0.90	0.90	0.90	0.90	0.90
Heavy Vehicles (%)	5%	2%	8%	5%	2%	5%	5%	2%	5%	5%
Adj. Flow (vph)	0	2319	410	0	1780	0	0	437	0	0
Shared Lane Traffic (%)										
Lane Group Flow (vph)	0	2319	410	0	1780	0	0	437	0	0
Turn Type			Perm					custom		
Protected Phases		Free			6			4		
Permitted Phases			Free							
Detector Phase					6			4		
Switch Phase										
Minimum Initial (s)					12.0			7.0		
Minimum Split (s)					18.0			13.0		
Total Split (s)	0.0	0.0	0.0	0.0	126.0	0.0	0.0	44.0	0.0	0.0
Total Split (%)	0.0%	0.0%	0.0%	0.0%	74.1%	0.0%	0.0%	25.9%	0.0%	0.0%
Maximum Green (s)					120.2			38.9		
Yellow Time (s)					4.8			4.1		
All-Red Time (s)					1.0			1.0		
Lost Time Adjust (s)	0.0	0.0	0.0	0.0	-0.8	0.0	0.0	-0.1	-2.0	0.0
Total Lost Time (s)	4.0	4.0	4.0	4.0	5.0	4.0	4.0	5.0	2.0	4.0
Lead/Lag										
Lead-Lag Optimize?										
Vehicle Extension (s)					2.0			1.0		
Recall Mode					C-Max			None		
Act Effct Green (s)		170.0	170.0		130.1			29.9		
Actuated g/C Ratio		1.00	1.00		0.77			0.18		
v/c Ratio		0.67	0.28		0.65			0.88		
Control Delay		1.8	0.0		12.7			86.9		
Queue Delay		0.0	0.0		0.1			0.5		
Total Delay		1.8	0.0		12.8			87.4		
LOS		A	A		B			F		
Approach Delay		1.5			12.8					

Lanes, Volumes, Timings
 7: US 64 & I-26 SB Off-Ramp

2040 Design Year - Build 6 Lanes

Timing Plan: PM Peak

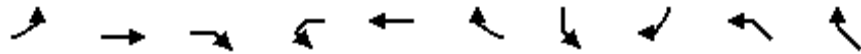

Lane Group	EBL	EBT	EBR	WBL	WBT	WBR	SBL	SBR	NWL	NWR
Approach LOS	A			B						
Queue Length 50th (ft)		10	0		429			273		
Queue Length 95th (ft)		m0	m0		m658			330		
Internal Link Dist (ft)		648			665		727		270	
Turn Bay Length (ft)								500		
Base Capacity (vph)		3486	1473		2748			649		
Starvation Cap Reductn		0	0		0			0		
Spillback Cap Reductn		0	0		117			36		
Storage Cap Reductn		0	0		0			0		
Reduced v/c Ratio		0.67	0.28		0.68			0.71		

Intersection Summary

Area Type: Other
 Cycle Length: 170
 Actuated Cycle Length: 170
 Offset: 0 (0%), Referenced to phase 6:WBT, Start of Green, Master Intersection
 Natural Cycle: 60
 Control Type: Actuated-Coordinated
 Maximum v/c Ratio: 0.88
 Intersection Signal Delay: 13.1
 Intersection LOS: B
 Intersection Capacity Utilization 103.2%
 ICU Level of Service G
 Analysis Period (min) 15
 m Volume for 95th percentile queue is metered by upstream signal.

Splits and Phases: 7: US 64 & I-26 SB Off-Ramp



Lanes, Volumes, Timings
8: US 64 & SR 1634 (Carolina Village Rd)

2040 Design Year - Build 6 Lanes

Timing Plan: PM Peak



Lane Group	EBL	EBT	EBR	WBL	WBT	WBR	NBL	NBT	NBR	SBL	SBT	SBR
Lane Configurations												
Volume (vph)	100	1982	81	184	1593	237	86	5	243	208	5	70
Ideal Flow (vphpl)	1900	1900	1900	1900	1900	1900	1900	1900	1900	1900	1900	1900
Grade (%)		1%			-3%			3%			-1%	
Storage Length (ft)	100		0	100		0	0		0	0		150
Storage Lanes	1		0	1		1	0		0	0		1
Taper Length (ft)	100		100	100		100	100		100	100		100
Lane Util. Factor	1.00	0.95	0.95	1.00	0.95	1.00	1.00	1.00	1.00	1.00	1.00	1.00
Frt		0.994				0.850		0.902				0.850
Flt Protected	0.950			0.950				0.987			0.954	
Satd. Flow (prot)	1761	3500	0	1796	3592	1607	0	1633	0	0	1786	1591
Flt Permitted	0.950			0.950				0.612			0.379	
Satd. Flow (perm)	1761	3500	0	1796	3592	1607	0	1013	0	0	710	1591
Right Turn on Red			No			No			No			No
Satd. Flow (RTOR)												
Link Speed (mph)		45			45			30			30	
Link Distance (ft)		560			728			219			359	
Travel Time (s)		8.5			11.0			5.0			8.2	
Peak Hour Factor	0.90	0.90	0.90	0.90	0.90	0.90	0.90	0.90	0.90	0.90	0.90	0.90
Heavy Vehicles (%)	2%	2%	2%	2%	2%	2%	2%	2%	2%	2%	2%	2%
Adj. Flow (vph)	111	2202	90	204	1770	263	96	6	270	231	6	78
Shared Lane Traffic (%)												
Lane Group Flow (vph)	111	2292	0	204	1770	263	0	372	0	0	237	78
Turn Type	Prot			Prot		Perm	Perm			Perm		pm+ov
Protected Phases	5	2		1	6			8			4	5
Permitted Phases						6	8			4		4
Detector Phase	5	2		1	6	6	8	8		4	4	5
Switch Phase												
Minimum Initial (s)	7.0	12.0		7.0	12.0	12.0	7.0	7.0		7.0	7.0	7.0
Minimum Split (s)	13.0	18.0		13.0	19.0	19.0	13.0	13.0		13.0	13.0	13.0
Total Split (s)	16.0	96.0	0.0	20.0	100.0	100.0	54.0	54.0	0.0	54.0	54.0	16.0
Total Split (%)	9.4%	56.5%	0.0%	11.8%	58.8%	58.8%	31.8%	31.8%	0.0%	31.8%	31.8%	9.4%
Maximum Green (s)	10.1	90.4		14.6	93.8	93.8	48.2	48.2		48.1	48.1	10.1
Yellow Time (s)	3.0	4.4		3.0	4.8	4.8	3.4	3.4		3.6	3.6	3.0
All-Red Time (s)	2.9	1.2		2.4	1.4	1.4	2.4	2.4		2.3	2.3	2.9
Lost Time Adjust (s)	-0.9	-0.6	-2.0	-0.4	-1.2	-1.2	-2.0	-0.8	-2.0	-2.0	-0.9	-0.9
Total Lost Time (s)	5.0	5.0	2.0	5.0	5.0	5.0	3.8	5.0	2.0	3.9	5.0	5.0
Lead/Lag	Lag	Lag		Lead	Lead	Lead						Lag
Lead-Lag Optimize?	Yes	Yes		Yes	Yes	Yes						Yes
Vehicle Extension (s)	1.0	2.0		1.0	2.0	2.0	1.0	1.0		1.0	1.0	1.0
Recall Mode	None	C-Max		None	C-Max	C-Max	None	None		None	None	None
Act Effct Green (s)	11.0	91.0		15.0	95.0	95.0		49.0			49.0	65.0
Actuated g/C Ratio	0.06	0.54		0.09	0.56	0.56		0.29			0.29	0.38
v/c Ratio	0.97	1.22		1.29	0.88	0.29		1.27			1.16	0.13
Control Delay	153.6	140.8		220.2	29.7	15.4		194.4			162.8	34.9
Queue Delay	0.0	0.0		0.0	5.3	0.0		0.0			0.0	0.0
Total Delay	153.6	140.8		220.2	35.0	15.4		194.4			162.8	34.9
LOS	F	F		F	D	B		F			F	C
Approach Delay		141.3			49.6			194.4			131.1	

Lanes, Volumes, Timings
 8: US 64 & SR 1634 (Carolina Village Rd)

2040 Design Year - Build 6 Lanes

Timing Plan: PM Peak



Lane Group	EBL	EBT	EBR	WBL	WBT	WBR	NBL	NBT	NBR	SBL	SBT	SBR
Approach LOS		F				D				F		
Queue Length 50th (ft)	126	~1645			~288	762	112		~521		~311	56
Queue Length 95th (ft)	#265	#1762			#473	714	169		#738		#500	98
Internal Link Dist (ft)		480				648			139		279	
Turn Bay Length (ft)	100			100								150
Base Capacity (vph)	114	1874			158	2007	898		292		205	608
Starvation Cap Reductn	0	0			0	193	0		0		0	0
Spillback Cap Reductn	0	0			0	0	0		0		0	0
Storage Cap Reductn	0	0			0	0	0		0		0	0
Reduced v/c Ratio	0.97	1.22			1.29	0.98	0.29		1.27		1.16	0.13

Intersection Summary

Area Type: Other
 Cycle Length: 170
 Actuated Cycle Length: 170
 Offset: 158 (93%), Referenced to phase 2:EBT and 6:WBT, Start of Green
 Natural Cycle: 170
 Control Type: Actuated-Coordinated
 Maximum v/c Ratio: 1.29
 Intersection Signal Delay: 105.9
 Intersection LOS: F
 Intersection Capacity Utilization 115.8%
 ICU Level of Service H
 Analysis Period (min) 15
 ~ Volume exceeds capacity, queue is theoretically infinite.
 Queue shown is maximum after two cycles.
 # 95th percentile volume exceeds capacity, queue may be longer.
 Queue shown is maximum after two cycles.

Splits and Phases: 8: US 64 & SR 1634 (Carolina Village Rd)



Lanes, Volumes, Timings
 9: SR 1783 (Upward Rd) & I-26 NB On-Ramp

2040 Design Year - Build 6 Lanes

Timing Plan: PM Peak



Lane Group	EBL	EBT	EBR	WBL	WBT	WBR	NBL	NBT	NBR	SBL	SBT	SBR
Lane Configurations	↗↘	↗↗			↖↗		↖	↖	↖			
Volume (vph)	785	695	0	0	550	158	509	0	181	0	0	0
Ideal Flow (vphpl)	1900	1900	1900	1900	1900	1900	1900	1900	1900	1900	1900	1900
Grade (%)		-3%			3%			4%				0%
Storage Length (ft)	275		0	0		0	250		175	0		0
Storage Lanes	1		0	0		0	1		1	0		0
Taper Length (ft)	100		100	100		100	100		100	100		100
Lane Util. Factor	0.97	0.95	1.00	1.00	0.95	0.95	0.95	0.95	1.00	1.00	1.00	1.00
Frt					0.966				0.850			
Flt Protected	0.950						0.950	0.950				
Satd. Flow (prot)	3291	3592	0	0	3346	0	1648	1648	1552	0	0	0
Flt Permitted	0.950						0.950	0.950				
Satd. Flow (perm)	3291	3592	0	0	3346	0	1648	1648	1552	0	0	0
Right Turn on Red			No			No			No			No
Satd. Flow (RTOR)												
Link Speed (mph)		45			45			35			45	
Link Distance (ft)		630			322			532			658	
Travel Time (s)		9.5			4.9			10.4			10.0	
Peak Hour Factor	0.90	0.90	0.90	0.90	0.90	0.90	0.90	0.90	0.90	0.90	0.90	0.90
Heavy Vehicles (%)	8%	2%	5%	5%	2%	5%	2%	2%	2%	5%	5%	5%
Adj. Flow (vph)	872	772	0	0	611	176	566	0	201	0	0	0
Shared Lane Traffic (%)							50%					
Lane Group Flow (vph)	872	772	0	0	787	0	283	283	201	0	0	0
Turn Type	Prot						Split		Prot			
Protected Phases	5	2			6		8	8	8			
Permitted Phases												
Detector Phase	5	2			6		8	8	8			
Switch Phase												
Minimum Initial (s)	7.0	14.0			14.0		7.0	7.0	7.0			
Minimum Split (s)	14.0	22.0			21.0		19.0	19.0	19.0			
Total Split (s)	33.0	66.0	0.0	0.0	33.0	0.0	24.0	24.0	24.0	0.0	0.0	0.0
Total Split (%)	36.7%	73.3%	0.0%	0.0%	36.7%	0.0%	26.7%	26.7%	26.7%	0.0%	0.0%	0.0%
Maximum Green (s)	26.7	59.8			27.4		17.9	17.9	17.9			
Yellow Time (s)	3.0	5.1			4.6		3.6	3.6	3.6			
All-Red Time (s)	3.3	1.1			1.0		2.5	2.5	2.5			
Lost Time Adjust (s)	-1.3	-1.2	0.0	0.0	-0.6	0.0	-1.1	-1.1	-1.1	-2.0	0.0	0.0
Total Lost Time (s)	5.0	5.0	4.0	4.0	5.0	4.0	5.0	5.0	5.0	2.0	4.0	4.0
Lead/Lag	Lag				Lead							
Lead-Lag Optimize?	Yes				Yes							
Vehicle Extension (s)	2.0	2.0			2.0		2.0	2.0	2.0			
Minimum Gap (s)	3.0	3.1			3.1		3.0	3.0	3.0			
Time Before Reduce (s)	0.0	15.0			15.0		0.0	0.0	0.0			
Time To Reduce (s)	0.0	45.0			45.0		0.0	0.0	0.0			
Recall Mode	None	C-Max			C-Max		None	None	None			
Act Effct Green (s)	28.0	61.9			28.9		18.1	18.1	18.1			
Actuated g/C Ratio	0.31	0.69			0.32		0.20	0.20	0.20			
v/c Ratio	0.85	0.31			0.73		0.85	0.85	0.64			
Control Delay	24.7	2.3			32.2		59.3	59.3	43.2			
Queue Delay	0.0	0.0			0.0		0.0	0.0	0.0			

Lanes, Volumes, Timings
 9: SR 1783 (Upward Rd) & I-26 NB On-Ramp

2040 Design Year - Build 6 Lanes
 Timing Plan: PM Peak



Lane Group	EBL	EBT	EBR	WBL	WBT	WBR	NBL	NBT	NBR	SBL	SBT	SBR
Total Delay	24.7	2.3			32.2		59.3	59.3	43.2			
LOS	C	A			C		E	E	D			
Approach Delay		14.2			32.2			55.1				
Approach LOS		B			C			E				
Queue Length 50th (ft)	245	26			210		162	162	104			
Queue Length 95th (ft)	#342	32			280		#298	#298	178			
Internal Link Dist (ft)		550			242			452			578	
Turn Bay Length (ft)	275						250		175			
Base Capacity (vph)	1024	2472			1075		348	348	328			
Starvation Cap Reductn	0	0			0		0	0	0			
Spillback Cap Reductn	0	0			0		0	0	0			
Storage Cap Reductn	0	0			0		0	0	0			
Reduced v/c Ratio	0.85	0.31			0.73		0.81	0.81	0.61			

Intersection Summary

Area Type: Other
 Cycle Length: 90
 Actuated Cycle Length: 90
 Offset: 80 (89%), Referenced to phase 2:EBT and 6:WBT, Start of Green
 Natural Cycle: 70
 Control Type: Actuated-Coordinated
 Maximum v/c Ratio: 0.85
 Intersection Signal Delay: 28.4
 Intersection LOS: C
 Intersection Capacity Utilization 69.2%
 ICU Level of Service C
 Analysis Period (min) 15
 # 95th percentile volume exceeds capacity, queue may be longer.
 Queue shown is maximum after two cycles.

Splits and Phases: 9: SR 1783 (Upward Rd) & I-26 NB On-Ramp

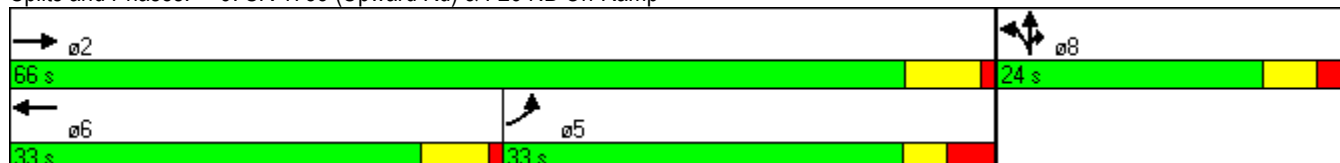

Lanes, Volumes, Timings
 10: SR 1783 (Upward Rd) & I-26 SB Off-Ramp

2040 Design Year - Build 6 Lanes

Timing Plan: PM Peak



Lane Group	EBL	EBT	EBR	WBL	WBT	WBR	NBL	NBT	NBR	SBL	SBT	SBR
Lane Configurations		↑↑↑	↗	↘	↑↑						↖	↗↗
Volume (vph)	0	1319	524	142	917	0	0	0	0	161	0	613
Ideal Flow (vphpl)	1900	1900	1900	1900	1900	1900	1900	1900	1900	1900	1900	1900
Grade (%)		4%			-4%			0%			5%	
Storage Length (ft)	275		0	150		0	0		0	250		0
Storage Lanes	1		1	1		0	0		0	1		2
Taper Length (ft)	100		100	100		100	100		100	100		100
Lane Util. Factor	1.00	0.91	1.00	1.00	0.95	1.00	1.00	1.00	1.00	1.00	1.00	0.88
Frt			0.850									0.850
Flt Protected				0.950							0.950	
Satd. Flow (prot)	0	4984	1465	1705	3610	0	0	0	0	0	1725	2717
Flt Permitted				0.094							0.950	
Satd. Flow (perm)	0	4984	1465	169	3610	0	0	0	0	0	1725	2717
Right Turn on Red			No			No			No			No
Satd. Flow (RTOR)												
Link Speed (mph)		45			45			45			35	
Link Distance (ft)		549			630			547			651	
Travel Time (s)		8.3			9.5			8.3			12.7	
Peak Hour Factor	0.90	0.90	0.90	0.90	0.90	0.90	0.90	0.90	0.90	0.90	0.90	0.90
Heavy Vehicles (%)	5%	2%	8%	8%	2%	5%	5%	5%	5%	2%	2%	2%
Adj. Flow (vph)	0	1466	582	158	1019	0	0	0	0	179	0	681
Shared Lane Traffic (%)												
Lane Group Flow (vph)	0	1466	582	158	1019	0	0	0	0	0	179	681
Turn Type			Perm		pm+pt					Split		Prot
Protected Phases		2		1	6					4	4	4
Permitted Phases			2		6							
Detector Phase		2		2	1		6			4	4	4
Switch Phase												
Minimum Initial (s)		14.0	14.0	7.0	14.0					7.0	7.0	7.0
Minimum Split (s)		20.0	20.0	14.0	21.0					13.0	13.0	13.0
Total Split (s)	0.0	46.0	46.0	14.0	60.0	0.0	0.0	0.0	0.0	30.0	30.0	30.0
Total Split (%)	0.0%	51.1%	51.1%	15.6%	66.7%	0.0%	0.0%	0.0%	0.0%	33.3%	33.3%	33.3%
Maximum Green (s)		40.4	40.4	7.6	53.6					24.1	24.1	24.1
Yellow Time (s)		4.5	4.5	3.0	5.2					3.6	3.6	3.6
All-Red Time (s)		1.1	1.1	3.4	1.2					2.3	2.3	2.3
Lost Time Adjust (s)	0.0	-0.6	-0.6	-1.4	-1.4	-2.0	0.0	0.0	0.0	-2.0	-0.9	-0.9
Total Lost Time (s)	4.0	5.0	5.0	5.0	5.0	2.0	4.0	4.0	4.0	3.9	5.0	5.0
Lead/Lag		Lag		Lag		Lead						
Lead-Lag Optimize?		Yes		Yes		Yes						
Vehicle Extension (s)		2.0	2.0	2.0	2.0					2.0	2.0	2.0
Minimum Gap (s)		3.1	3.1	3.0	3.1					3.0	3.0	3.0
Time Before Reduce (s)		15.0	15.0	0.0	15.0					0.0	0.0	0.0
Time To Reduce (s)		45.0	45.0	0.0	45.0					0.0	0.0	0.0
Recall Mode		C-Max		C-Max		None		C-Max		None		None
Act Effct Green (s)		41.8	41.8	55.5	55.5						24.5	24.5
Actuated g/C Ratio		0.46	0.46	0.62	0.62						0.27	0.27
v/c Ratio		0.63	0.86	0.62	0.46						0.38	0.92
Control Delay		20.0	36.5	19.9	4.6						29.3	51.6
Queue Delay		0.0	0.0	0.0	0.0						0.0	0.0

Lanes, Volumes, Timings
 10: SR 1783 (Upward Rd) & I-26 SB Off-Ramp

2040 Design Year - Build 6 Lanes

Timing Plan: PM Peak



Lane Group	EBL	EBT	EBR	WBL	WBT	WBR	NBL	NBT	NBR	SBL	SBT	SBR
Total Delay		20.0	36.5	19.9	4.6						29.3	51.6
LOS		C	D	B	A						C	D
Approach Delay		24.7			6.6						46.9	
Approach LOS		C			A						D	
Queue Length 50th (ft)		227	288	20	156						82	211
Queue Length 95th (ft)		276	#498	m31	192						141	#325
Internal Link Dist (ft)		469			550			467			571	
Turn Bay Length (ft)				150								
Base Capacity (vph)		2312	680	258	2228						479	755
Starvation Cap Reductn		0	0	0	0						0	0
Spillback Cap Reductn		0	0	0	0						0	0
Storage Cap Reductn		0	0	0	0						0	0
Reduced v/c Ratio		0.63	0.86	0.61	0.46						0.37	0.90

Intersection Summary

Area Type: Other
 Cycle Length: 90
 Actuated Cycle Length: 90
 Offset: 0 (0%), Referenced to phase 2:EBT and 6:WBTL, Start of Green
 Natural Cycle: 80
 Control Type: Actuated-Coordinated
 Maximum v/c Ratio: 0.92
 Intersection Signal Delay: 24.2
 Intersection LOS: C
 Intersection Capacity Utilization 69.2%
 ICU Level of Service C
 Analysis Period (min) 15
 # 95th percentile volume exceeds capacity, queue may be longer.
 Queue shown is maximum after two cycles.
 m Volume for 95th percentile queue is metered by upstream signal.

Splits and Phases: 10: SR 1783 (Upward Rd) & I-26 SB Off-Ramp



2040 Build 8 Lane

Lanes, Volumes, Timings
1: NC 146 (Long Shoals Rd) & I-26 NB On-Ramp

2040 Design Year - Build 8 Lanes

Timing Plan: AM Peak

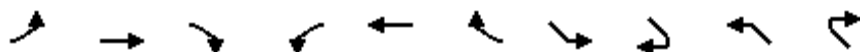

Lane Group	EBL	EBT	EBR2	WBL	WBT	WBR2	SEL	SER2	NWL	NWR2
Lane Configurations	↗↘	↗↗	↗	↗↘	↗↗	↗	↗↘	↗	↗↘	↗
Volume (vph)	352	877	405	591	1160	875	843	448	411	454
Ideal Flow (vphpl)	1900	1900	1900	1900	1900	1900	1900	1900	1900	1900
Grade (%)		3%			-7%					
Storage Length (ft)	450			350			0		675	
Storage Lanes	1			2			2		1	
Taper Length (ft)	100			100			100		100	
Lane Util. Factor	0.97	0.95	1.00	0.97	0.95	1.00	0.97	1.00	0.97	1.00
Frt			0.850			0.850		0.850		0.850
Flt Protected	0.950			0.950			0.950		0.950	
Satd. Flow (prot)	3224	3452	1487	3387	3663	1562	3519	1607	3434	1599
Flt Permitted	0.950			0.950			0.950		0.950	
Satd. Flow (perm)	3224	3452	1487	3387	3663	1562	3519	1607	3434	1599
Right Turn on Red			No			No		No		No
Satd. Flow (RTOR)										
Link Speed (mph)		45			45					
Link Distance (ft)		1009			964					
Travel Time (s)		15.3			14.6					
Peak Hour Factor	0.90	0.90	0.90	0.90	0.90	0.90	0.90	0.90	0.90	0.90
Heavy Vehicles (%)	7%	3%	7%	7%	2%	7%	2%	3%	3%	2%
Adj. Flow (vph)	391	974	450	657	1289	972	937	498	457	504
Shared Lane Traffic (%)										
Lane Group Flow (vph)	391	974	450	657	1289	972	937	498	457	504
Turn Type	Prot		Free	Prot		Free	Prot	custom	Prot	Free
Protected Phases	5	2		1	6		4		8	
Permitted Phases			Free			Free		4		Free
Detector Phase	5	2		1	6		4	4	8	
Switch Phase										
Minimum Initial (s)	7.0	12.0		7.0	12.0		7.0	7.0	7.0	
Minimum Split (s)	16.0	20.0		15.0	21.0		16.0	16.0	15.0	
Total Split (s)	18.0	39.0	0.0	24.0	45.0	0.0	37.0	37.0	37.0	0.0
Total Split (%)	18.0%	39.0%	0.0%	24.0%	45.0%	0.0%	37.0%	37.0%	37.0%	0.0%
Maximum Green (s)	9.8	31.5		16.3	36.0		28.9	28.9	29.0	
Yellow Time (s)	3.4	4.3		4.0	5.2		3.8	3.8	3.7	
All-Red Time (s)	4.8	3.2		3.7	3.8		4.3	4.3	4.3	
Lost Time Adjust (s)	-3.2	-2.5	-2.5	-2.7	-4.0	-4.0	-3.1	-3.1	-3.0	0.0
Total Lost Time (s)	5.0	5.0	1.5	5.0	5.0	0.0	5.0	5.0	5.0	4.0
Lead/Lag	Lead	Lag		Lead	Lag					
Lead-Lag Optimize?	Yes	Yes		Yes	Yes					
Vehicle Extension (s)	2.0	6.0		2.0	6.0		2.0	2.0	2.0	
Minimum Gap (s)	3.0	3.0		3.0	3.0		3.0	3.0	3.0	
Time Before Reduce (s)	0.0	15.0		0.0	15.0		0.0	0.0	0.0	
Time To Reduce (s)	0.0	30.0		0.0	30.0		0.0	0.0	0.0	
Recall Mode	None	C-Max		None	C-Max		None	None	None	
Act Effct Green (s)	13.0	34.0	100.0	19.0	40.0	100.0	32.0	32.0	32.0	100.0
Actuated g/C Ratio	0.13	0.34	1.00	0.19	0.40	1.00	0.32	0.32	0.32	1.00
v/c Ratio	0.93	0.83	0.30	1.02	0.88	0.62	0.83	0.97	0.42	0.32
Control Delay	74.2	37.7	0.5	81.7	36.2	1.9	39.3	67.7	28.1	0.5
Queue Delay	0.0	0.0	0.0	0.0	0.0	0.0	0.0	0.0	0.0	0.0

Lanes, Volumes, Timings
 1: NC 146 (Long Shoals Rd) & I-26 NB On-Ramp

2040 Design Year - Build 8 Lanes

Timing Plan: AM Peak

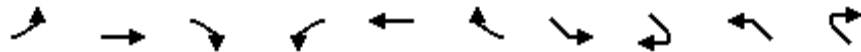

Lane Group	EBL	EBT	EBR2	WBL	WBT	WBR2	SEL	SER2	NWL	NWR2
Total Delay	74.2	37.7	0.5	81.7	36.2	1.9	39.3	67.7	28.1	0.5
LOS	E	D	A	F	D	A	D	E	C	A
Approach Delay	36.4			35.0						
Approach LOS	D			D						
Queue Length 50th (ft)	129	297	0	~224	392	0	283	311	117	0
Queue Length 95th (ft)	#218	380	0	#341	#497	0	362	#519	161	0
Internal Link Dist (ft)	929			884						
Turn Bay Length (ft)	450		300	350		300		425	675	575
Base Capacity (vph)	419	1174	1487	644	1465	1562	1126	514	1099	1599
Starvation Cap Reductn	0	0	0	0	0	0	0	0	0	0
Spillback Cap Reductn	0	0	0	0	0	0	0	0	0	0
Storage Cap Reductn	0	0	0	0	0	0	0	0	0	0
Reduced v/c Ratio	0.93	0.83	0.30	1.02	0.88	0.62	0.83	0.97	0.42	0.32

Intersection Summary

Area Type: Other
 Cycle Length: 100
 Actuated Cycle Length: 100
 Offset: 0 (0%), Referenced to phase 2:EBT and 6:WBT, Start of Green
 Natural Cycle: 90
 Control Type: Actuated-Coordinated
 Maximum v/c Ratio: 1.02
 Intersection Signal Delay: 35.3
 Intersection LOS: D
 Intersection Capacity Utilization 83.2%
 ICU Level of Service E
 Analysis Period (min) 15
 ~ Volume exceeds capacity, queue is theoretically infinite.
 Queue shown is maximum after two cycles.
 # 95th percentile volume exceeds capacity, queue may be longer.
 Queue shown is maximum after two cycles.

Splits and Phases: 1: NC 146 (Long Shoals Rd) & I-26 NB On-Ramp

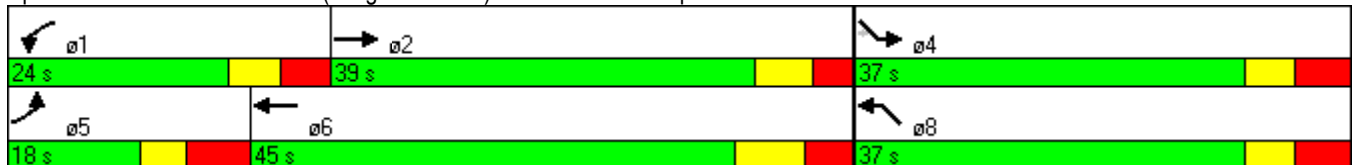

Lanes, Volumes, Timings
2: I-26 NB On-Ramp & US 25 (Asheville Highway)

2040 Design Year - Build 8 Lanes

Timing Plan: AM Peak



Lane Group	EBL	EBT	EBR	WBL	WBT	WBR	NBL	NBT	NBR	SBL	SBT	SBR
Lane Configurations				↖		↖↖	↖	↖↖			↖↖	↖
Volume (vph)	0	0	0	229	0	517	726	1163	0	0	1723	326
Ideal Flow (vphpl)	1900	1900	1900	1900	1900	1900	1900	1900	1900	1900	1900	1900
Grade (%)		0%			2%			-1%			2%	
Storage Length (ft)	0		0	0		150	0		0	0		300
Storage Lanes	0		0	1		2	1		0	0		1
Taper Length (ft)	100		100	100		100	100		100	100		100
Lane Util. Factor	1.00	1.00	1.00	1.00	1.00	0.88	1.00	0.95	1.00	1.00	0.95	1.00
Frt						0.850						0.850
Flt Protected				0.950			0.950					
Satd. Flow (prot)	0	0	0	1735	0	2706	1680	3489	0	0	3436	1480
Flt Permitted				0.950			0.950					
Satd. Flow (perm)	0	0	0	1735	0	2706	1680	3489	0	0	3436	1480
Right Turn on Red			No			Yes			No			No
Satd. Flow (RTOR)						211						
Link Speed (mph)		45			35			45			45	
Link Distance (ft)		533			612			601			596	
Travel Time (s)		8.1			11.9			9.1			9.0	
Peak Hour Factor	0.90	0.90	0.90	0.90	0.90	0.90	0.90	0.90	0.90	0.90	0.90	0.90
Heavy Vehicles (%)	5%	5%	5%	3%	5%	4%	8%	4%	5%	5%	4%	8%
Adj. Flow (vph)	0	0	0	254	0	574	807	1292	0	0	1914	362
Shared Lane Traffic (%)												
Lane Group Flow (vph)	0	0	0	254	0	574	807	1292	0	0	1914	362
Turn Type				Prot		custom	Prot					Free
Protected Phases				4			5	2			6	
Permitted Phases						4						Free
Detector Phase				4		4	5	2			6	
Switch Phase												
Minimum Initial (s)				7.0		7.0	7.0	12.0			12.0	
Minimum Split (s)				13.0		13.0	14.0	19.0			18.0	
Total Split (s)	0.0	0.0	0.0	20.0	0.0	20.0	42.0	90.0	0.0	0.0	48.0	0.0
Total Split (%)	0.0%	0.0%	0.0%	18.2%	0.0%	18.2%	38.2%	81.8%	0.0%	0.0%	43.6%	0.0%
Maximum Green (s)				14.0		14.0	35.6	83.9			42.7	
Yellow Time (s)				3.7		3.7	3.0	4.6			4.3	
All-Red Time (s)				2.3		2.3	3.4	1.5			1.0	
Lost Time Adjust (s)	-2.0	0.0	0.0	-1.0	0.0	-1.0	-1.4	-1.1	0.0	0.0	-0.3	0.0
Total Lost Time (s)	2.0	4.0	4.0	5.0	4.0	5.0	5.0	5.0	4.0	4.0	5.0	4.0
Lead/Lag							Lag				Lead	
Lead-Lag Optimize?							Yes				Yes	
Vehicle Extension (s)				2.0		2.0	2.0	8.0			8.0	
Minimum Gap (s)				3.0		3.0	3.0	5.5			5.5	
Time Before Reduce (s)				0.0		0.0	0.0	15.0			15.0	
Time To Reduce (s)				0.0		0.0	0.0	50.0			50.0	
Recall Mode				None		None	None	C-Max			C-Max	
Act Effct Green (s)				15.0		15.0	37.0	85.0			43.0	110.0
Actuated g/C Ratio				0.14		0.14	0.34	0.77			0.39	1.00
v/c Ratio				1.07		1.04	1.43	0.48			1.43	0.24
Control Delay				124.6		79.5	217.2	1.2			224.8	0.4
Queue Delay				0.0		0.0	0.0	0.5			0.0	0.0

Lanes, Volumes, Timings
 2: I-26 NB On-Ramp & US 25 (Asheville Highway)

2040 Design Year - Build 8 Lanes

Timing Plan: AM Peak



Lane Group	EBL	EBT	EBR	WBL	WBT	WBR	NBL	NBT	NBR	SBL	SBT	SBR
Total Delay				124.6		79.5	217.2	1.7			224.8	0.4
LOS				F		E	F	A			F	A
Approach Delay								84.5			189.1	
Approach LOS								F			F	
Queue Length 50th (ft)				~200		~171	~784	15			~963	0
Queue Length 95th (ft)				#362		#294	m#486	m26			#1102	0
Internal Link Dist (ft)		453			532			521			516	
Turn Bay Length (ft)						150						300
Base Capacity (vph)				237		551	565	2696			1343	1480
Starvation Cap Reductn				0		0	0	829			0	0
Spillback Cap Reductn				0		0	0	0			0	0
Storage Cap Reductn				0		0	0	0			0	0
Reduced v/c Ratio				1.07		1.04	1.43	0.69			1.43	0.24

Intersection Summary

Area Type: Other
 Cycle Length: 110
 Actuated Cycle Length: 110
 Offset: 49 (45%), Referenced to phase 2:NBT and 6:SBT, Start of Green
 Natural Cycle: 200
 Control Type: Actuated-Coordinated
 Maximum v/c Ratio: 1.43
 Intersection Signal Delay: 131.7
 Intersection LOS: F
 Intersection Capacity Utilization 113.0%
 ICU Level of Service H
 Analysis Period (min) 15
 ~ Volume exceeds capacity, queue is theoretically infinite.
 Queue shown is maximum after two cycles.
 # 95th percentile volume exceeds capacity, queue may be longer.
 Queue shown is maximum after two cycles.
 m Volume for 95th percentile queue is metered by upstream signal.

Splits and Phases: 2: I-26 NB On-Ramp & US 25 (Asheville Highway)

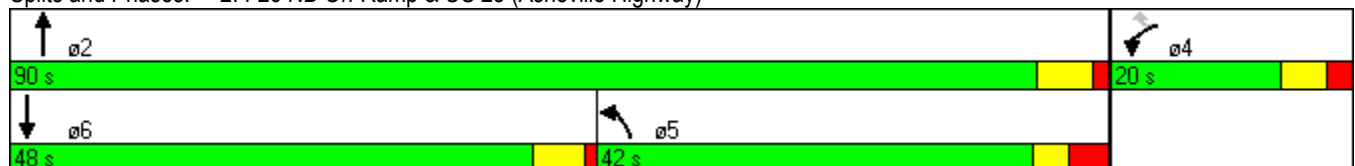

Lanes, Volumes, Timings
 3: I-26 SB Off-Ramp & US 25 (Asheville Highway)

2040 Design Year - Build 8 Lanes

Timing Plan: AM Peak



Lane Group	EBL	EBT	EBR	WBL	WBT	WBR	NBL	NBT	NBR	SBL	SBT	SBR
Lane Configurations	↘		↗					↑↑	↗	↘	↑↑	
Volume (vph)	319	0	903	0	0	0	0	1570	228	652	1300	0
Ideal Flow (vphpl)	1900	1900	1900	1900	1900	1900	1900	1900	1900	1900	1900	1900
Grade (%)		3%			0%			4%			1%	
Storage Length (ft)	0		100	0		0	0		500	0		0
Storage Lanes	1		1	0		0	0		1	1		0
Taper Length (ft)	100		100	100		100	100		100	100		100
Lane Util. Factor	1.00	1.00	1.00	1.00	1.00	1.00	1.00	0.95	1.00	1.00	0.95	1.00
Frt			0.850						0.850			
Flt Protected	0.950									0.950		
Satd. Flow (prot)	1710	0	1544	0	0	0	0	3435	1465	1663	3487	0
Flt Permitted	0.950									0.950		
Satd. Flow (perm)	1710	0	1544	0	0	0	0	3435	1465	1663	3487	0
Right Turn on Red			No			No			No			No
Satd. Flow (RTOR)												
Link Speed (mph)		35			45			45			45	
Link Distance (ft)		471			598			795			601	
Travel Time (s)		9.2			9.1			12.0			9.1	
Peak Hour Factor	0.90	0.90	0.90	0.90	0.90	0.90	0.90	0.90	0.90	0.90	0.90	0.90
Heavy Vehicles (%)	4%	5%	3%	5%	5%	5%	5%	3%	8%	8%	3%	5%
Adj. Flow (vph)	354	0	1003	0	0	0	0	1744	253	724	1444	0
Shared Lane Traffic (%)												
Lane Group Flow (vph)	354	0	1003	0	0	0	0	1744	253	724	1444	0
Turn Type	Prot		custom						Free	Prot		
Protected Phases	4		4					2		1	6	
Permitted Phases									Free			
Detector Phase	4		4					2		1	6	
Switch Phase												
Minimum Initial (s)	7.0		7.0					12.0		7.0	12.0	
Minimum Split (s)	13.0		13.0					18.0		14.0	18.0	
Total Split (s)	43.0	0.0	43.0	0.0	0.0	0.0	0.0	42.0	0.0	25.0	67.0	0.0
Total Split (%)	39.1%	0.0%	39.1%	0.0%	0.0%	0.0%	0.0%	38.2%	0.0%	22.7%	60.9%	0.0%
Maximum Green (s)	37.0		37.0					36.3		18.5	61.3	
Yellow Time (s)	4.0		4.0					4.7		4.0	4.7	
All-Red Time (s)	2.0		2.0					1.0		2.5	1.0	
Lost Time Adjust (s)	-1.0	-2.0	-1.0	-2.0	-2.0	-2.0	-2.0	-0.7	-0.7	-1.5	-0.7	-2.0
Total Lost Time (s)	5.0	2.0	5.0	2.0	2.0	2.0	2.0	5.0	3.3	5.0	5.0	2.0
Lead/Lag								Lag		Lead		
Lead-Lag Optimize?								Yes		Yes		
Vehicle Extension (s)	2.0		2.0					8.0		2.0	8.0	
Minimum Gap (s)	3.0		3.0					5.5		3.0	5.5	
Time Before Reduce (s)	0.0		0.0					15.0		0.0	15.0	
Time To Reduce (s)	0.0		0.0					50.0		0.0	50.0	
Recall Mode	None		None					C-Max		None	C-Max	
Act Effct Green (s)	38.0		38.0					37.0	110.0	20.0	62.0	
Actuated g/C Ratio	0.35		0.35					0.34	1.00	0.18	0.56	
v/c Ratio	0.60		1.88					1.51	0.17	2.40	0.73	
Control Delay	34.8		429.0					263.4	0.3	656.2	2.1	
Queue Delay	0.0		0.0					0.0	0.0	0.0	0.7	

Lanes, Volumes, Timings
 3: I-26 SB Off-Ramp & US 25 (Asheville Highway)

2040 Design Year - Build 8 Lanes

Timing Plan: AM Peak



Lane Group	EBL	EBT	EBR	WBL	WBT	WBR	NBL	NBT	NBR	SBL	SBT	SBR
Total Delay	34.8		429.0					263.4	0.3	656.2	2.8	
LOS	C		F					F	A	F	A	
Approach Delay								230.1			221.0	
Approach LOS								F			F	
Queue Length 50th (ft)	205		~1085					~904	0	~865	0	
Queue Length 95th (ft)	304		#1332					#1043	0	m#567	m0	
Internal Link Dist (ft)		391			518			715				521
Turn Bay Length (ft)			100						500			
Base Capacity (vph)	591		533					1155	1465	302	1965	
Starvation Cap Reductn	0		0					0	0	0	222	
Spillback Cap Reductn	0		0					0	0	0	0	
Storage Cap Reductn	0		0					0	0	0	0	
Reduced v/c Ratio	0.60		1.88					1.51	0.17	2.40	0.83	

Intersection Summary

Area Type: Other
 Cycle Length: 110
 Actuated Cycle Length: 110
 Offset: 64 (58%), Referenced to phase 2:NBT and 6:SBT, Start of Green
 Natural Cycle: 240
 Control Type: Actuated-Coordinated
 Maximum v/c Ratio: 2.40
 Intersection Signal Delay: 250.1
 Intersection LOS: F
 Intersection Capacity Utilization 113.0%
 ICU Level of Service H
 Analysis Period (min) 15
 ~ Volume exceeds capacity, queue is theoretically infinite.
 Queue shown is maximum after two cycles.
 # 95th percentile volume exceeds capacity, queue may be longer.
 Queue shown is maximum after two cycles.
 m Volume for 95th percentile queue is metered by upstream signal.

Splits and Phases: 3: I-26 SB Off-Ramp & US 25 (Asheville Highway)

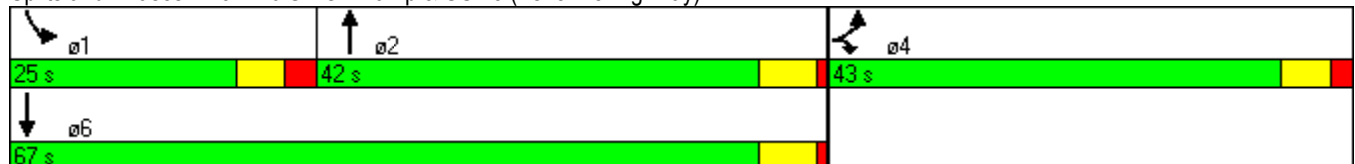

Lanes, Volumes, Timings
4: I-26 NB Ramps & Balfour Pkwy

2040 Design Year - Build 8 Lanes

Timing Plan: AM Peak



Lane Group	EBL	EBT	EBR	WBL	WBT	WBR	NBL	NBT	NBR	SBL	SBT	SBR
Lane Configurations			↗↗			↗	↖	↕↕			↕↕	↗
Volume (vph)	0	0	748	0	0	199	377	1418	0	0	1124	847
Ideal Flow (vphpl)	1900	1900	1900	1900	1900	1900	1900	1900	1900	1900	1900	1900
Storage Length (ft)	0		0	0		0	250		0	0		250
Storage Lanes	0		2	0		1	1		0	0		1
Taper Length (ft)	100		100	100		100	100		100	100		100
Lane Util. Factor	1.00	1.00	0.88	1.00	1.00	1.00	1.00	0.95	1.00	1.00	0.95	1.00
Frt			0.850			0.865						0.850
Flt Protected							0.950					
Satd. Flow (prot)	0	0	2787	0	0	1611	1671	3539	0	0	3539	1495
Flt Permitted							0.950					
Satd. Flow (perm)	0	0	2787	0	0	1611	1671	3539	0	0	3539	1495
Right Turn on Red			No			No			No			No
Satd. Flow (RTOR)												
Link Speed (mph)		25			45			45				45
Link Distance (ft)		393			429			690				522
Travel Time (s)		10.7			6.5			10.5				7.9
Peak Hour Factor	0.90	0.90	0.90	0.90	0.90	0.90	0.90	0.90	0.90	0.90	0.90	0.90
Heavy Vehicles (%)	5%	5%	2%	5%	5%	2%	8%	2%	5%	5%	2%	8%
Adj. Flow (vph)	0	0	831	0	0	221	419	1576	0	0	1249	941
Shared Lane Traffic (%)												
Lane Group Flow (vph)	0	0	831	0	0	221	419	1576	0	0	1249	941
Turn Type			Over			Free	Prot					Perm
Protected Phases			5				5	Free				6
Permitted Phases						Free						6
Detector Phase			5				5					6
Switch Phase												
Minimum Initial (s)			7.0				7.0				12.0	12.0
Minimum Split (s)			14.0				14.0				19.0	19.0
Total Split (s)	0.0	0.0	30.0	0.0	0.0	0.0	30.0	0.0	0.0	0.0	60.0	60.0
Total Split (%)	0.0%	0.0%	33.3%	0.0%	0.0%	0.0%	33.3%	0.0%	0.0%	0.0%	66.7%	66.7%
Maximum Green (s)			23.0				23.0				53.0	53.0
Yellow Time (s)			5.0				5.0				5.0	5.0
All-Red Time (s)			2.0				2.0				2.0	2.0
Lost Time Adjust (s)	-2.0	-2.0	-2.0	-2.0	-2.0	-2.0	-2.0	-2.0	-2.0	-2.0	-2.0	-2.0
Total Lost Time (s)	2.0	2.0	5.0	2.0	2.0	2.0	5.0	2.0	2.0	2.0	5.0	5.0
Lead/Lag			Lead				Lead				Lag	Lag
Lead-Lag Optimize?			Yes				Yes				Yes	Yes
Vehicle Extension (s)			3.0				3.0				3.0	3.0
Recall Mode			None				None				C-Max	C-Max
Act Effct Green (s)			25.0			90.0	25.0	90.0			55.0	55.0
Actuated g/C Ratio			0.28			1.00	0.28	1.00			0.61	0.61
v/c Ratio			1.07			0.14	0.90	0.45			0.58	1.03
Control Delay			86.8			0.2	46.6	0.3			11.9	57.3
Queue Delay			0.0			0.0	0.0	0.0			0.0	0.0
Total Delay			86.8			0.2	46.6	0.3			11.9	57.3
LOS			F			A	D	A			B	E
Approach Delay								10.0			31.4	
Approach LOS								B			C	

Lanes, Volumes, Timings
 4: I-26 NB Ramps & Balfour Pkwy

2040 Design Year - Build 8 Lanes

Timing Plan: AM Peak

Lane Group	EBL	EBT	EBR	WBL	WBT	WBR	NBL	NBT	NBR	SBL	SBT	SBR
Queue Length 50th (ft)			~301			0	229	0			204	~579
Queue Length 95th (ft)			#428			0	m#365	0			262	#809
Internal Link Dist (ft)		313			349			610			442	
Turn Bay Length (ft)							250					250
Base Capacity (vph)			774			1611	464	3539			2163	914
Starvation Cap Reductn			0			0	0	0			0	0
Spillback Cap Reductn			0			0	0	0			0	0
Storage Cap Reductn			0			0	0	0			0	0
Reduced v/c Ratio			1.07			0.14	0.90	0.45			0.58	1.03

Intersection Summary

Area Type: Other
 Cycle Length: 90
 Actuated Cycle Length: 90
 Offset: 41 (46%), Referenced to phase 6:SBT, Start of Green
 Natural Cycle: 100
 Control Type: Actuated-Coordinated
 Maximum v/c Ratio: 1.07
 Intersection Signal Delay: 30.7
 Intersection LOS: C
 Intersection Capacity Utilization 81.7%
 ICU Level of Service D
 Analysis Period (min) 15
 ~ Volume exceeds capacity, queue is theoretically infinite.
 Queue shown is maximum after two cycles.
 # 95th percentile volume exceeds capacity, queue may be longer.
 Queue shown is maximum after two cycles.
 m Volume for 95th percentile queue is metered by upstream signal.

Splits and Phases: 4: I-26 NB Ramps & Balfour Pkwy



Lanes, Volumes, Timings
5: I-26 SB Ramps & Balfour Pkwy

2040 Design Year - Build 8 Lanes

Timing Plan: AM Peak

Lane Group	EBL	EBT	EBR	WBL	WBT	WBR	NBL	NBT	NBR	SBL	SBT	SBR
Lane Configurations												
Volume (vph)	0	0	498	0	0	704	0	991	724	268	1604	0
Ideal Flow (vphpl)	1900	1900	1900	1900	1900	1900	1900	1900	1900	1900	1900	1900
Storage Length (ft)	0		0	0		0	0		250	250		0
Storage Lanes	0		1	0		2	0		1	1		0
Taper Length (ft)	100		100	100		100	100		100	100		100
Lane Util. Factor	1.00	1.00	1.00	1.00	1.00	0.88	1.00	0.95	1.00	1.00	0.95	1.00
Frt			0.865			0.850			0.850			
Flt Protected										0.950		
Satd. Flow (prot)	0	0	1611	0	0	2787	0	3539	1495	1671	3539	0
Flt Permitted										0.950		
Satd. Flow (perm)	0	0	1611	0	0	2787	0	3539	1495	1671	3539	0
Right Turn on Red			No			No			No			No
Satd. Flow (RTOR)												
Link Speed (mph)		45			25			45			45	
Link Distance (ft)		642			361			480			690	
Travel Time (s)		9.7			9.8			7.3			10.5	
Peak Hour Factor	0.90	0.90	0.90	0.90	0.90	0.90	0.90	0.90	0.90	0.90	0.90	0.90
Heavy Vehicles (%)	5%	5%	2%	5%	5%	2%	5%	2%	8%	8%	2%	5%
Adj. Flow (vph)	0	0	553	0	0	782	0	1101	804	298	1782	0
Shared Lane Traffic (%)												
Lane Group Flow (vph)	0	0	553	0	0	782	0	1101	804	298	1782	0
Turn Type			Free			Over			Perm	Prot		
Protected Phases						1		2		1	Free	
Permitted Phases			Free						2			
Detector Phase						1		2	2	1		
Switch Phase												
Minimum Initial (s)						7.0		12.0	12.0	7.0		
Minimum Split (s)						14.0		19.0	19.0	14.0		
Total Split (s)	0.0	0.0	0.0	0.0	0.0	35.0	0.0	55.0	55.0	35.0	0.0	0.0
Total Split (%)	0.0%	0.0%	0.0%	0.0%	0.0%	38.9%	0.0%	61.1%	61.1%	38.9%	0.0%	0.0%
Maximum Green (s)						28.0		48.0	48.0	28.0		
Yellow Time (s)						5.0		5.0	5.0	5.0		
All-Red Time (s)						2.0		2.0	2.0	2.0		
Lost Time Adjust (s)	-2.0	-2.0	-2.0	-2.0	-2.0	-2.0	-2.0	-2.0	-2.0	-2.0	-2.0	-2.0
Total Lost Time (s)	2.0	2.0	2.0	2.0	2.0	5.0	2.0	5.0	5.0	5.0	2.0	2.0
Lead/Lag						Lead		Lag	Lag	Lead		
Lead-Lag Optimize?						Yes		Yes	Yes	Yes		
Vehicle Extension (s)						3.0		3.0	3.0	3.0		
Recall Mode						None		C-Max	C-Max	None		
Act Effct Green (s)			90.0			29.3		50.7	50.7	29.3	90.0	
Actuated g/C Ratio			1.00			0.33		0.56	0.56	0.33	1.00	
v/c Ratio			0.34			0.86		0.55	0.95	0.55	0.50	
Control Delay			0.6			39.7		13.9	42.5	23.1	0.3	
Queue Delay			0.0			0.0		0.0	0.0	0.0	0.0	
Total Delay			0.6			39.7		13.9	42.5	23.1	0.3	
LOS			A			D		B	D	C	A	
Approach Delay								26.0			3.6	
Approach LOS								C			A	

Lanes, Volumes, Timings
5: I-26 SB Ramps & Balfour Pkwy

2040 Design Year - Build 8 Lanes

Timing Plan: AM Peak



Lane Group	EBL	EBT	EBR	WBL	WBT	WBR	NBL	NBT	NBR	SBL	SBT	SBR
Queue Length 50th (ft)			0			231		198	411	133	0	
Queue Length 95th (ft)			0			#340		256	#686	m168	m0	
Internal Link Dist (ft)		562			281			400				610
Turn Bay Length (ft)									250	250		
Base Capacity (vph)			1611			929		1994	843	557	3539	
Starvation Cap Reductn			0			0		0	0	0	0	
Spillback Cap Reductn			0			0		0	0	0	0	
Storage Cap Reductn			0			0		0	0	0	0	
Reduced v/c Ratio			0.34			0.84		0.55	0.95	0.54	0.50	

Intersection Summary

Area Type: Other
 Cycle Length: 90
 Actuated Cycle Length: 90
 Offset: 0 (0%), Referenced to phase 2:NBT, Start of Green
 Natural Cycle: 75
 Control Type: Actuated-Coordinated
 Maximum v/c Ratio: 0.95
 Intersection Signal Delay: 16.6
 Intersection LOS: B
 Intersection Capacity Utilization 68.0%
 ICU Level of Service C
 Analysis Period (min) 15
 # 95th percentile volume exceeds capacity, queue may be longer.
 Queue shown is maximum after two cycles.
 m Volume for 95th percentile queue is metered by upstream signal.

Splits and Phases: 5: I-26 SB Ramps & Balfour Pkwy



Lanes, Volumes, Timings
6: US 64 & SR 1516 (Francis Rd)

2040 Design Year - Build 8 Lanes

Timing Plan: AM Peak



Lane Group	EBL	EBT	EBR	WBL	WBT	WBR	NBL	NBT	NBR	SBL	SBT	SBR
Lane Configurations												
Volume (vph)	181	1762	535	34	2260	12	467	5	23	8	5	158
Ideal Flow (vphpl)	1900	1900	1900	1900	1900	1900	1900	1900	1900	1900	1900	1900
Grade (%)		-1%			4%			-1%			2%	
Storage Length (ft)	150		0	125		0	150		150	0		150
Storage Lanes	1		1	1		0	1		1	0		1
Taper Length (ft)	100		100	100		100	100		100	100		100
Lane Util. Factor	1.00	0.95	1.00	1.00	0.95	0.95	0.95	0.95	1.00	1.00	1.00	1.00
Frt			0.850		0.999				0.850			0.850
Flt Protected	0.950			0.950			0.950	0.953			0.971	
Satd. Flow (prot)	1778	3557	1591	1734	3465	0	1690	1695	1591	0	1791	1567
Flt Permitted	0.950			0.950			0.950	0.953			0.971	
Satd. Flow (perm)	1778	3557	1591	1734	3465	0	1690	1695	1591	0	1791	1567
Right Turn on Red			No			No			No			No
Satd. Flow (RTOR)												
Link Speed (mph)		45			45			35			35	
Link Distance (ft)		835			622			375			406	
Travel Time (s)		12.7			9.4			7.3			7.9	
Peak Hour Factor	0.90	0.90	0.90	0.90	0.90	0.90	0.90	0.90	0.90	0.90	0.90	0.90
Heavy Vehicles (%)	2%	2%	2%	2%	2%	2%	2%	2%	2%	2%	2%	2%
Adj. Flow (vph)	201	1958	594	38	2511	13	519	6	26	9	6	176
Shared Lane Traffic (%)							49%					
Lane Group Flow (vph)	201	1958	594	38	2524	0	265	260	26	0	15	176
Turn Type	Prot		Perm	Prot			Split		pm+ov	Split		pm+ov
Protected Phases	5	2		1	6		4	4	1	3	3	5
Permitted Phases			2						4			3
Detector Phase	5	2	2	1	6		4	4	1	3	3	5
Switch Phase												
Minimum Initial (s)	7.0	12.0	12.0	7.0	12.0		7.0	7.0	7.0	7.0	7.0	7.0
Minimum Split (s)	13.0	18.0	18.0	13.0	18.0		14.0	14.0	13.0	14.0	14.0	13.0
Total Split (s)	18.0	98.0	98.0	14.0	94.0	0.0	24.0	24.0	14.0	14.0	14.0	18.0
Total Split (%)	12.0%	65.3%	65.3%	9.3%	62.7%	0.0%	16.0%	16.0%	9.3%	9.3%	9.3%	12.0%
Maximum Green (s)	12.4	92.0	92.0	8.6	88.4		17.4	17.4	8.6	7.5	7.5	12.4
Yellow Time (s)	3.2	4.6	4.6	3.0	4.2		3.9	3.9	3.0	3.7	3.7	3.2
All-Red Time (s)	2.4	1.4	1.4	2.4	1.4		2.7	2.7	2.4	2.8	2.8	2.4
Lost Time Adjust (s)	-0.6	-1.0	-1.0	-0.4	-0.6	-2.0	-1.6	-1.6	-0.4	-2.0	-1.5	-0.6
Total Lost Time (s)	5.0	5.0	5.0	5.0	5.0	2.0	5.0	5.0	5.0	4.5	5.0	5.0
Lead/Lag	Lag	Lag	Lag	Lead	Lead		Lag	Lag	Lead	Lead	Lead	Lag
Lead-Lag Optimize?	Yes	Yes	Yes	Yes	Yes		Yes	Yes	Yes	Yes	Yes	Yes
Vehicle Extension (s)	1.0	2.0	2.0	1.0	2.0		1.0	1.0	1.0	1.0	1.0	1.0
Recall Mode	None	C-Max	C-Max	None	C-Max		None	None	None	None	None	None
Act Effct Green (s)	13.0	96.5	96.5	7.9	89.0		27.6	27.6	40.5		8.5	18.4
Actuated g/C Ratio	0.09	0.64	0.64	0.05	0.59		0.18	0.18	0.27		0.06	0.12
v/c Ratio	1.31	0.86	0.58	0.41	1.23		0.85	0.83	0.06		0.15	0.92
Control Delay	220.0	17.9	13.0	82.2	136.3		82.5	80.4	44.3		70.9	109.0
Queue Delay	0.0	0.0	0.0	0.0	0.0		0.0	0.0	0.0		0.0	0.0
Total Delay	220.0	17.9	13.0	82.2	136.3		82.5	80.4	44.3		70.9	109.0
LOS	F	B	B	F	F		F	F	D		E	F
Approach Delay		31.6			135.5			79.7			106.0	

Lanes, Volumes, Timings
6: US 64 & SR 1516 (Francis Rd)

2040 Design Year - Build 8 Lanes

Timing Plan: AM Peak



Lane Group	EBL	EBT	EBR	WBL	WBT	WBR	NBL	NBT	NBR	SBL	SBT	SBR
Approach LOS	C			F			E			F		
Queue Length 50th (ft)	~251	408	198	37	~1597		254	249	18		14	~219
Queue Length 95th (ft)	#420	608	251	78	#1716		#525	#514	48		40	249
Internal Link Dist (ft)	755			542			295			326		
Turn Bay Length (ft)	150			125			150		150			150
Base Capacity (vph)	154	2289	1024	104	2056		311	312	441		107	192
Starvation Cap Reductn	0	0	0	0	0		0	0	0		0	0
Spillback Cap Reductn	0	0	0	0	0		0	0	0		0	0
Storage Cap Reductn	0	0	0	0	0		0	0	0		0	0
Reduced v/c Ratio	1.31	0.86	0.58	0.37	1.23		0.85	0.83	0.06		0.14	0.92

Intersection Summary

Area Type: Other
 Cycle Length: 150
 Actuated Cycle Length: 150
 Offset: 27 (18%), Referenced to phase 2:EBT and 6:WBT, Start of Green
 Natural Cycle: 240
 Control Type: Actuated-Coordinated
 Maximum v/c Ratio: 1.31
 Intersection Signal Delay: 82.3
 Intersection Capacity Utilization 105.1%
 Analysis Period (min) 15
 Intersection LOS: F
 ICU Level of Service G

~ Volume exceeds capacity, queue is theoretically infinite.
 Queue shown is maximum after two cycles.

95th percentile volume exceeds capacity, queue may be longer.
 Queue shown is maximum after two cycles.

Splits and Phases: 6: US 64 & SR 1516 (Francis Rd)



Lanes, Volumes, Timings
7: US 64 & I-26 SB Off-Ramp

2040 Design Year - Build 8 Lanes

Timing Plan: AM Peak

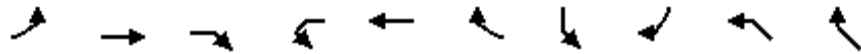

Lane Group	EBL	EBT	EBR	WBL	WBT	WBR	SBL	SBR	NWL	NWR
Lane Configurations		↑↑	↑		↑↑			↑↑		
Volume (vph)	0	1669	345	0	1963	0	0	526	0	0
Ideal Flow (vphpl)	1900	1900	1900	1900	1900	1900	1900	1900	1900	1900
Grade (%)		3%			-3%		-3%		0%	
Storage Length (ft)	0		400	0		0	0	500	0	0
Storage Lanes	0		1	0		0	0	1	0	0
Taper Length (ft)	100		100	100		100	100	100	100	100
Lane Util. Factor	1.00	0.95	1.00	1.00	0.95	1.00	1.00	0.88	1.00	1.00
Frt			0.850					0.850		
Flt Protected										
Satd. Flow (prot)	0	3486	1473	0	3592	0	0	2828	0	0
Flt Permitted										
Satd. Flow (perm)	0	3486	1473	0	3592	0	0	2828	0	0
Right Turn on Red			No			No		No		
Satd. Flow (RTOR)										
Link Speed (mph)		45			45		35		45	
Link Distance (ft)		728			791		804		308	
Travel Time (s)		11.0			12.0		15.7		4.7	
Peak Hour Factor	0.90	0.90	0.90	0.90	0.90	0.90	0.90	0.90	0.90	0.90
Heavy Vehicles (%)	5%	2%	8%	5%	2%	5%	5%	2%	5%	5%
Adj. Flow (vph)	0	1854	383	0	2181	0	0	584	0	0
Shared Lane Traffic (%)										
Lane Group Flow (vph)	0	1854	383	0	2181	0	0	584	0	0
Turn Type			Perm					custom		
Protected Phases		Free			6			4		
Permitted Phases			Free							
Detector Phase					6			4		
Switch Phase										
Minimum Initial (s)					12.0			7.0		
Minimum Split (s)					18.0			13.0		
Total Split (s)	0.0	0.0	0.0	0.0	109.0	0.0	0.0	41.0	0.0	0.0
Total Split (%)	0.0%	0.0%	0.0%	0.0%	72.7%	0.0%	0.0%	27.3%	0.0%	0.0%
Maximum Green (s)					103.2			35.9		
Yellow Time (s)					4.8			4.1		
All-Red Time (s)					1.0			1.0		
Lost Time Adjust (s)	-2.0	0.0	-2.0	-2.0	-0.8	-2.0	-2.0	-0.1	-2.0	-2.0
Total Lost Time (s)	2.0	4.0	2.0	2.0	5.0	2.0	2.0	5.0	2.0	2.0
Lead/Lag										
Lead-Lag Optimize?										
Vehicle Extension (s)					2.0			1.0		
Recall Mode					C-Max			None		
Act Effct Green (s)		150.0	150.0		106.7			33.3		
Actuated g/C Ratio		1.00	1.00		0.71			0.22		
v/c Ratio		0.53	0.26		0.85			0.93		
Control Delay		0.1	0.0		18.0			79.0		
Queue Delay		0.0	0.0		0.0			0.0		
Total Delay		0.1	0.0		18.0			79.0		
LOS		A	A		B			E		
Approach Delay		0.1			18.0					

Lanes, Volumes, Timings
7: US 64 & I-26 SB Off-Ramp

2040 Design Year - Build 8 Lanes

Timing Plan: AM Peak

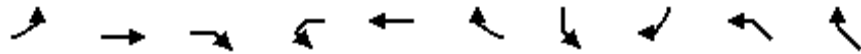

Lane Group	EBL	EBT	EBR	WBL	WBT	WBR	SBL	SBR	NWL	NWR
Approach LOS	A			B						
Queue Length 50th (ft)	0		0	677			315			
Queue Length 95th (ft)	m0		m0	m445			#417			
Internal Link Dist (ft)	648			711			724		228	
Turn Bay Length (ft)	400						500			
Base Capacity (vph)	3486		1473	2554			679			
Starvation Cap Reductn	0		0	0			0			
Spillback Cap Reductn	0		0	0			0			
Storage Cap Reductn	0		0	0			0			
Reduced v/c Ratio	0.53		0.26	0.85			0.86			

Intersection Summary

Area Type: Other

Cycle Length: 150

Actuated Cycle Length: 150

Offset: 0 (0%), Referenced to phase 6:WBT, Start of Green, Master Intersection

Natural Cycle: 80

Control Type: Actuated-Coordinated

Maximum v/c Ratio: 0.93

Intersection Signal Delay: 17.1

Intersection LOS: B

Intersection Capacity Utilization 96.6%

ICU Level of Service F

Analysis Period (min) 15

95th percentile volume exceeds capacity, queue may be longer.

Queue shown is maximum after two cycles.

m Volume for 95th percentile queue is metered by upstream signal.

Splits and Phases: 7: US 64 & I-26 SB Off-Ramp



Lanes, Volumes, Timings
8: US 64 & SR 1634 (Carolina Village Rd)

2040 Design Year - Build 8 Lanes

Timing Plan: AM Peak



Lane Group	EBL	EBT	EBR	WBL	WBT	WBR	NBL	NBT	NBR	SBL	SBT	SBR
Lane Configurations												
Volume (vph)	66	1606	81	248	1999	213	77	5	189	243	5	94
Ideal Flow (vphpl)	1900	1900	1900	1900	1900	1900	1900	1900	1900	1900	1900	1900
Grade (%)		1%			-3%			3%			-1%	
Storage Length (ft)	100		0	100		0	0		0	0		150
Storage Lanes	1		0	1		1	0		0	0		1
Taper Length (ft)	100		100	100		100	100		100	100		100
Lane Util. Factor	1.00	0.95	0.95	1.00	0.95	1.00	1.00	1.00	1.00	1.00	1.00	1.00
Frt		0.993				0.850		0.906				0.850
Flt Protected	0.950			0.950				0.986			0.953	
Satd. Flow (prot)	1761	3497	0	1796	3592	1607	0	1639	0	0	1784	1591
Flt Permitted	0.950			0.950				0.565			0.434	
Satd. Flow (perm)	1761	3497	0	1796	3592	1607	0	939	0	0	812	1591
Right Turn on Red			No			No			No			No
Satd. Flow (RTOR)												
Link Speed (mph)		45			45			30			30	
Link Distance (ft)		560			728			219			359	
Travel Time (s)		8.5			11.0			5.0			8.2	
Peak Hour Factor	0.90	0.90	0.90	0.90	0.90	0.90	0.90	0.90	0.90	0.90	0.90	0.90
Heavy Vehicles (%)	2%	2%	2%	2%	2%	2%	2%	2%	2%	2%	2%	2%
Adj. Flow (vph)	73	1784	90	276	2221	237	86	6	210	270	6	104
Shared Lane Traffic (%)												
Lane Group Flow (vph)	73	1874	0	276	2221	237	0	302	0	0	276	104
Turn Type	Prot			Prot		Perm	Perm			Perm		pm+ov
Protected Phases	5	2		1	6			8			4	5
Permitted Phases						6	8			4		4
Detector Phase	5	2		1	6	6	8	8		4	4	5
Switch Phase												
Minimum Initial (s)	7.0	12.0		7.0	12.0	12.0	7.0	7.0		7.0	7.0	7.0
Minimum Split (s)	13.0	18.0		13.0	19.0	19.0	13.0	13.0		13.0	13.0	13.0
Total Split (s)	13.0	78.0	0.0	24.0	89.0	89.0	48.0	48.0	0.0	48.0	48.0	13.0
Total Split (%)	8.7%	52.0%	0.0%	16.0%	59.3%	59.3%	32.0%	32.0%	0.0%	32.0%	32.0%	8.7%
Maximum Green (s)	7.1	72.4		18.6	82.8	82.8	42.2	42.2		42.1	42.1	7.1
Yellow Time (s)	3.0	4.4		3.0	4.8	4.8	3.4	3.4		3.6	3.6	3.0
All-Red Time (s)	2.9	1.2		2.4	1.4	1.4	2.4	2.4		2.3	2.3	2.9
Lost Time Adjust (s)	-0.9	-0.6	-2.0	-0.4	-1.2	-1.2	-2.0	-0.8	-2.0	-2.0	-0.9	-0.9
Total Lost Time (s)	5.0	5.0	2.0	5.0	5.0	5.0	3.8	5.0	2.0	3.9	5.0	5.0
Lead/Lag	Lag	Lag		Lead	Lead	Lead						Lag
Lead-Lag Optimize?	Yes	Yes		Yes	Yes	Yes						Yes
Vehicle Extension (s)	1.0	2.0		1.0	2.0	2.0	1.0	1.0		1.0	1.0	1.0
Recall Mode	None	C-Max		None	C-Max	C-Max	None	None		None	None	None
Act Effct Green (s)	8.0	73.0		19.0	84.0	84.0		43.0			43.0	56.0
Actuated g/C Ratio	0.05	0.49		0.13	0.56	0.56		0.29			0.29	0.37
v/c Ratio	0.78	1.10		1.22	1.10	0.26		1.12			1.18	0.18
Control Delay	115.1	91.7		168.7	80.2	17.4		139.8			163.7	32.6
Queue Delay	0.0	0.0		0.0	41.9	0.0		0.0			0.0	0.0
Total Delay	115.1	91.7		168.7	122.1	17.4		139.8			163.7	32.6
LOS	F	F		F	F	B		F			F	C
Approach Delay		92.5			117.7			139.8			127.8	

Lanes, Volumes, Timings
 8: US 64 & SR 1634 (Carolina Village Rd)

2040 Design Year - Build 8 Lanes

Timing Plan: AM Peak



Lane Group	EBL	EBT	EBR	WBL	WBT	WBR	NBL	NBT	NBR	SBL	SBT	SBR	
Approach LOS	F			F			F			F			
Queue Length 50th (ft)	72	~1092		~331	~1290	107	~340			~324	68		
Queue Length 95th (ft)	#164	#1227		m#428	#1425	m144	#534			#512	114		
Internal Link Dist (ft)	480			648			139			279			
Turn Bay Length (ft)	100	100									150		
Base Capacity (vph)	94	1702		227	2012	900	269			233	594		
Starvation Cap Reductn	0	0		0	160	0	0			0	0		
Spillback Cap Reductn	0	0		0	0	0	0			0	0		
Storage Cap Reductn	0	0		0	0	0	0			0	0		
Reduced v/c Ratio	0.78	1.10		1.22	1.20	0.26	1.12			1.18	0.18		

Intersection Summary

Area Type: Other
 Cycle Length: 150
 Actuated Cycle Length: 150
 Offset: 145 (97%), Referenced to phase 2:EBT and 6:WBT, Start of Green
 Natural Cycle: 180
 Control Type: Actuated-Coordinated
 Maximum v/c Ratio: 1.22
 Intersection Signal Delay: 110.5 Intersection LOS: F
 Intersection Capacity Utilization 107.6% ICU Level of Service G
 Analysis Period (min) 15
 ~ Volume exceeds capacity, queue is theoretically infinite.
 Queue shown is maximum after two cycles.
 # 95th percentile volume exceeds capacity, queue may be longer.
 Queue shown is maximum after two cycles.
 m Volume for 95th percentile queue is metered by upstream signal.

Splits and Phases: 8: US 64 & SR 1634 (Carolina Village Rd)



Lanes, Volumes, Timings
 9: SR 1783 (Upward Rd) & I-26 NB On-Ramp

2040 Design Year - Build 8 Lanes

Timing Plan: AM Peak



Lane Group	EBL	EBT	EBR	WBL	WBT	WBR	NBL	NBT	NBR	SBL	SBT	SBR
Lane Configurations	↖↗	↑↑			↑↑		↖	↗	↖			
Volume (vph)	664	563	0	0	689	168	506	0	128	0	0	0
Ideal Flow (vphpl)	1900	1900	1900	1900	1900	1900	1900	1900	1900	1900	1900	1900
Grade (%)		-3%			3%			4%			0%	
Storage Length (ft)	275		0	0		0	250		175	0		0
Storage Lanes	1		0	0		0	1		1	0		0
Taper Length (ft)	100		100	100		100	100		100	100		100
Lane Util. Factor	0.97	0.95	1.00	1.00	0.95	0.95	0.95	0.95	1.00	1.00	1.00	1.00
Frt					0.971				0.850			
Flt Protected	0.950						0.950	0.950				
Satd. Flow (prot)	3291	3592	0	0	3346	0	1648	1648	1552	0	0	0
Flt Permitted	0.950						0.950	0.950				
Satd. Flow (perm)	3291	3592	0	0	3346	0	1648	1648	1552	0	0	0
Right Turn on Red			No			No			No			No
Satd. Flow (RTOR)												
Link Speed (mph)		45			45			35			45	
Link Distance (ft)		630			322			532			658	
Travel Time (s)		9.5			4.9			10.4			10.0	
Peak Hour Factor	0.90	0.90	0.90	0.90	0.90	0.90	0.90	0.90	0.90	0.90	0.90	0.90
Heavy Vehicles (%)	8%	2%	5%	5%	2%	8%	2%	2%	2%	5%	5%	5%
Adj. Flow (vph)	738	626	0	0	766	187	562	0	142	0	0	0
Shared Lane Traffic (%)							50%					
Lane Group Flow (vph)	738	626	0	0	953	0	281	281	142	0	0	0
Turn Type	Prot						Split		Prot			
Protected Phases	5	2			6		8	8	8			
Permitted Phases												
Detector Phase	5	2			6		8	8	8			
Switch Phase												
Minimum Initial (s)	7.0	14.0			14.0		7.0	7.0	7.0			
Minimum Split (s)	14.0	22.0			21.0		19.0	19.0	19.0			
Total Split (s)	27.0	65.0	0.0	0.0	38.0	0.0	25.0	25.0	25.0	0.0	0.0	0.0
Total Split (%)	30.0%	72.2%	0.0%	0.0%	42.2%	0.0%	27.8%	27.8%	27.8%	0.0%	0.0%	0.0%
Maximum Green (s)	20.7	58.8			32.4		18.9	18.9	18.9			
Yellow Time (s)	3.0	5.1			4.6		3.6	3.6	3.6			
All-Red Time (s)	3.3	1.1			1.0		2.5	2.5	2.5			
Lost Time Adjust (s)	-1.3	-1.2	0.0	0.0	-0.6	-2.0	-1.1	-1.1	-1.1	-2.0	0.0	0.0
Total Lost Time (s)	5.0	5.0	4.0	4.0	5.0	2.0	5.0	5.0	5.0	2.0	4.0	4.0
Lead/Lag	Lag				Lead							
Lead-Lag Optimize?	Yes				Yes							
Vehicle Extension (s)	2.0	2.0			2.0		2.0	2.0	2.0			
Minimum Gap (s)	3.0	3.1			3.1		3.0	3.0	3.0			
Time Before Reduce (s)	0.0	15.0			15.0		0.0	0.0	0.0			
Time To Reduce (s)	0.0	45.0			45.0		0.0	0.0	0.0			
Recall Mode	None	C-Max			C-Max		None	None	None			
Act Effct Green (s)	22.0	61.5			34.5		18.5	18.5	18.5			
Actuated g/C Ratio	0.24	0.68			0.38		0.21	0.21	0.21			
v/c Ratio	0.92	0.25			0.74		0.83	0.83	0.45			
Control Delay	39.1	1.8			28.7		55.5	55.5	35.6			
Queue Delay	0.0	0.0			0.0		0.0	0.0	0.0			

Lanes, Volumes, Timings
 9: SR 1783 (Upward Rd) & I-26 NB On-Ramp

2040 Design Year - Build 8 Lanes

Timing Plan: AM Peak



Lane Group	EBL	EBT	EBR	WBL	WBT	WBR	NBL	NBT	NBR	SBL	SBT	SBR
Total Delay	39.1	1.8			28.7		55.5	55.5	35.6			
LOS	D	A			C		E	E	D			
Approach Delay		22.0			28.7			51.5				
Approach LOS		C			C			D				
Queue Length 50th (ft)	223	14			248		158	158	69			
Queue Length 95th (ft)	#323	24			325		#285	#285	126			
Internal Link Dist (ft)		550			242			452			578	
Turn Bay Length (ft)	275						250		175			
Base Capacity (vph)	804	2456			1283		366	366	345			
Starvation Cap Reductn	0	0			0		0	0	0			
Spillback Cap Reductn	0	0			0		0	0	0			
Storage Cap Reductn	0	0			0		0	0	0			
Reduced v/c Ratio	0.92	0.25			0.74		0.77	0.77	0.41			

Intersection Summary

Area Type: Other
 Cycle Length: 90
 Actuated Cycle Length: 90
 Offset: 7 (8%), Referenced to phase 2:EBT and 6:WBT, Start of Green
 Natural Cycle: 65
 Control Type: Actuated-Coordinated
 Maximum v/c Ratio: 0.92
 Intersection Signal Delay: 31.0
 Intersection LOS: C
 Intersection Capacity Utilization 69.9%
 ICU Level of Service C
 Analysis Period (min) 15
 # 95th percentile volume exceeds capacity, queue may be longer.
 Queue shown is maximum after two cycles.

Splits and Phases: 9: SR 1783 (Upward Rd) & I-26 NB On-Ramp

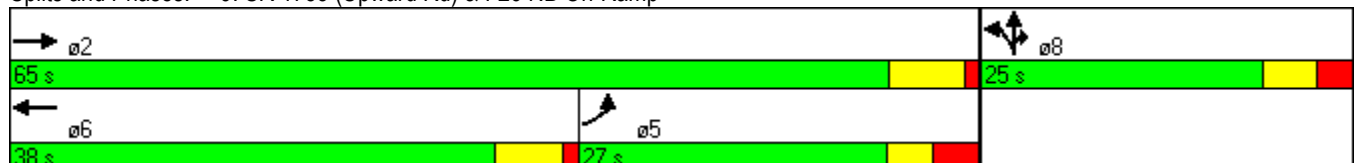

Lanes, Volumes, Timings
 10: SR 1783 (Upward Rd) & I-26 SB Off-Ramp

2040 Design Year - Build 8 Lanes

Timing Plan: AM Peak

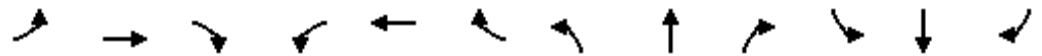

Lane Group	EBL	EBT	EBR	WBL	WBT	WBR	NBL	NBT	NBR	SBL	SBT	SBR
Lane Configurations		↑↑↑	↗	↘	↑↑						↖	↗↗
Volume (vph)	0	1064	493	165	1030	0	0	0	0	163	0	849
Ideal Flow (vphpl)	1900	1900	1900	1900	1900	1900	1900	1900	1900	1900	1900	1900
Grade (%)		4%			-4%			0%			5%	
Storage Length (ft)	275		0	150		0	0		0	250		0
Storage Lanes	1		1	1		0	0		0	1		2
Taper Length (ft)	100		100	100		100	100		100	100		100
Lane Util. Factor	1.00	0.91	1.00	1.00	0.95	1.00	1.00	1.00	1.00	1.00	1.00	0.88
Frt		0.850										0.850
Flt Protected				0.950							0.950	
Satd. Flow (prot)	0	4841	1507	1753	3507	0	0	0	0	0	1676	2639
Flt Permitted				0.133							0.950	
Satd. Flow (perm)	0	4841	1507	245	3507	0	0	0	0	0	1676	2639
Right Turn on Red			No			No			No			No
Satd. Flow (RTOR)												
Link Speed (mph)		45			45			45			35	
Link Distance (ft)		549			630			547			651	
Travel Time (s)		8.3			9.5			8.3			12.7	
Peak Hour Factor	0.90	0.90	0.90	0.90	0.90	0.90	0.90	0.90	0.90	0.90	0.90	0.90
Adj. Flow (vph)	0	1182	548	183	1144	0	0	0	0	181	0	943
Shared Lane Traffic (%)												
Lane Group Flow (vph)	0	1182	548	183	1144	0	0	0	0	0	181	943
Turn Type			Perm		pm+pt					Split		Prot
Protected Phases		2		1	6					4	4	4
Permitted Phases			2	6								
Detector Phase		2	2	1	6					4	4	4
Switch Phase												
Minimum Initial (s)		14.0	14.0	7.0	14.0					7.0	7.0	7.0
Minimum Split (s)		20.0	20.0	14.0	21.0					13.0	13.0	13.0
Total Split (s)	0.0	41.0	41.0	14.0	55.0	0.0	0.0	0.0	0.0	35.0	35.0	35.0
Total Split (%)	0.0%	45.6%	45.6%	15.6%	61.1%	0.0%	0.0%	0.0%	0.0%	38.9%	38.9%	38.9%
Maximum Green (s)		35.4	35.4	7.6	48.6					29.1	29.1	29.1
Yellow Time (s)		4.5	4.5	3.0	5.2					3.6	3.6	3.6
All-Red Time (s)		1.1	1.1	3.4	1.2					2.3	2.3	2.3
Lost Time Adjust (s)	-2.0	-0.6	-0.6	-1.4	-1.4	-2.0	0.0	0.0	0.0	-2.0	-0.9	-0.9
Total Lost Time (s)	2.0	5.0	5.0	5.0	5.0	2.0	4.0	4.0	4.0	3.9	5.0	5.0
Lead/Lag		Lag	Lag	Lead								
Lead-Lag Optimize?		Yes	Yes	Yes								
Vehicle Extension (s)		2.0	2.0	2.0	2.0					2.0	2.0	2.0
Minimum Gap (s)		3.1	3.1	3.0	3.1					3.0	3.0	3.0
Time Before Reduce (s)		15.0	15.0	0.0	15.0					0.0	0.0	0.0
Time To Reduce (s)		45.0	45.0	0.0	45.0					0.0	0.0	0.0
Recall Mode		C-Max	C-Max	None	C-Max					None	None	None
Act Effct Green (s)		36.1	36.1	50.0	50.0						30.0	30.0
Actuated g/C Ratio		0.40	0.40	0.56	0.56						0.33	0.33
v/c Ratio		0.61	0.91	0.64	0.59						0.32	1.07
Control Delay		23.0	46.8	18.6	3.5						24.5	82.1
Queue Delay		0.0	0.0	0.0	0.0						0.0	0.0
Total Delay		23.0	46.8	18.6	3.5						24.5	82.1

Lanes, Volumes, Timings
 10: SR 1783 (Upward Rd) & I-26 SB Off-Ramp

2040 Design Year - Build 8 Lanes

Timing Plan: AM Peak



Lane Group	EBL	EBT	EBR	WBL	WBT	WBR	NBL	NBT	NBR	SBL	SBT	SBR
LOS		C	D	B	A						C	F
Approach Delay		30.5			5.6						72.8	
Approach LOS		C			A						E	
Queue Length 50th (ft)		191	287	19	50						76	~341
Queue Length 95th (ft)		236	#492	m48	43						131	#472
Internal Link Dist (ft)		469			550			467			571	
Turn Bay Length (ft)				150								
Base Capacity (vph)		1943	605	287	1948						559	880
Starvation Cap Reductn		0	0	0	0						0	0
Spillback Cap Reductn		0	0	0	0						0	0
Storage Cap Reductn		0	0	0	0						0	0
Reduced v/c Ratio		0.61	0.91	0.64	0.59						0.32	1.07

Intersection Summary

Area Type: Other
 Cycle Length: 90
 Actuated Cycle Length: 90
 Offset: 12 (13%), Referenced to phase 2:EBT and 6:WBTL, Start of Green
 Natural Cycle: 90
 Control Type: Actuated-Coordinated
 Maximum v/c Ratio: 1.07
 Intersection Signal Delay: 34.0
 Intersection LOS: C
 Intersection Capacity Utilization 69.9%
 ICU Level of Service C
 Analysis Period (min) 15
 ~ Volume exceeds capacity, queue is theoretically infinite.
 Queue shown is maximum after two cycles.
 # 95th percentile volume exceeds capacity, queue may be longer.
 Queue shown is maximum after two cycles.
 m Volume for 95th percentile queue is metered by upstream signal.

Splits and Phases: 10: SR 1783 (Upward Rd) & I-26 SB Off-Ramp

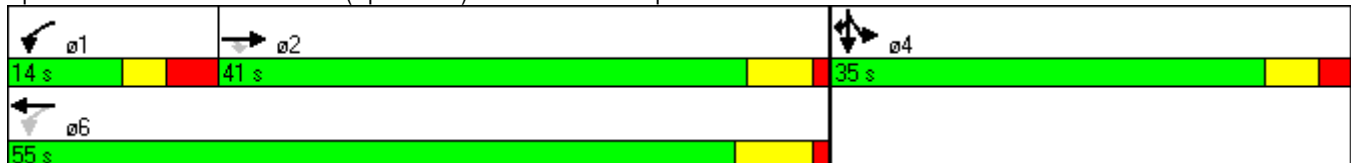

Lanes, Volumes, Timings
 1: NC 146 (Long Shoals Rd) & I-26 NB On-Ramp

2040 Design Year - Build 8 Lanes

Timing Plan: PM Peak

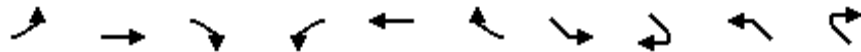

Lane Group	EBL	EBT	EBR2	WBL	WBT	WBR2	SEL	SER2	NWL	NWR2
Lane Configurations	↗↘	↗↗	↗	↗↘	↗↗	↗	↗↘	↗	↗↘	↗
Volume (vph)	448	1160	411	454	877	843	875	352	405	591
Ideal Flow (vphpl)	1900	1900	1900	1900	1900	1900	1900	1900	1900	1900
Grade (%)		3%			-7%					
Storage Length (ft)	450			350			0		675	
Storage Lanes	1			2			2		1	
Taper Length (ft)	100			100			100		100	
Lane Util. Factor	0.97	0.95	1.00	0.97	0.95	1.00	0.97	1.00	0.97	1.00
Frt			0.850			0.850		0.850		0.850
Flt Protected	0.950			0.950			0.950		0.950	
Satd. Flow (prot)	3224	3452	1487	3387	3663	1562	3519	1607	3434	1599
Flt Permitted	0.950			0.950			0.950		0.950	
Satd. Flow (perm)	3224	3452	1487	3387	3663	1562	3519	1607	3434	1599
Right Turn on Red			No			No		No		No
Satd. Flow (RTOR)										
Link Speed (mph)		45			45					
Link Distance (ft)		1009			964					
Travel Time (s)		15.3			14.6					
Peak Hour Factor	0.90	0.90	0.90	0.90	0.90	0.90	0.90	0.90	0.90	0.90
Heavy Vehicles (%)	7%	3%	7%	7%	2%	7%	2%	3%	3%	2%
Adj. Flow (vph)	498	1289	457	504	974	937	972	391	450	657
Shared Lane Traffic (%)										
Lane Group Flow (vph)	498	1289	457	504	974	937	972	391	450	657
Turn Type	Prot		Free	Prot		Free	Prot	custom	Prot	Free
Protected Phases	5	2		1	6		4		8	
Permitted Phases			Free			Free		4		Free
Detector Phase	5	2		1	6		4	4	8	
Switch Phase										
Minimum Initial (s)	7.0	12.0		7.0	12.0		7.0	7.0	7.0	
Minimum Split (s)	16.0	20.0		15.0	21.0		16.0	16.0	15.0	
Total Split (s)	24.0	47.0	0.0	19.0	42.0	0.0	34.0	34.0	34.0	0.0
Total Split (%)	24.0%	47.0%	0.0%	19.0%	42.0%	0.0%	34.0%	34.0%	34.0%	0.0%
Maximum Green (s)	15.8	39.5		11.3	33.0		25.9	25.9	26.0	
Yellow Time (s)	3.4	4.3		4.0	5.2		3.8	3.8	3.7	
All-Red Time (s)	4.8	3.2		3.7	3.8		4.3	4.3	4.3	
Lost Time Adjust (s)	-3.2	-2.5	-2.5	-2.7	-4.0	-4.0	-3.1	-3.1	-3.0	0.0
Total Lost Time (s)	5.0	5.0	1.5	5.0	5.0	0.0	5.0	5.0	5.0	4.0
Lead/Lag	Lead	Lag		Lead	Lag					
Lead-Lag Optimize?	Yes	Yes		Yes	Yes					
Vehicle Extension (s)	2.0	6.0		2.0	6.0		2.0	2.0	2.0	
Minimum Gap (s)	3.0	3.0		3.0	3.0		3.0	3.0	3.0	
Time Before Reduce (s)	0.0	15.0		0.0	15.0		0.0	0.0	0.0	
Time To Reduce (s)	0.0	30.0		0.0	30.0		0.0	0.0	0.0	
Recall Mode	None	C-Max		None	C-Max		None	None	None	
Act Effct Green (s)	18.8	42.0	100.0	14.0	37.2	100.0	29.0	29.0	29.0	100.0
Actuated g/C Ratio	0.19	0.42	1.00	0.14	0.37	1.00	0.29	0.29	0.29	1.00
v/c Ratio	0.82	0.89	0.31	1.06	0.72	0.60	0.95	0.84	0.45	0.41
Control Delay	51.5	36.0	0.5	101.4	30.5	1.7	54.4	51.0	30.8	0.8
Queue Delay	0.0	0.0	0.0	0.0	0.0	0.0	0.0	0.0	0.0	0.0

Lanes, Volumes, Timings
 1: NC 146 (Long Shoals Rd) & I-26 NB On-Ramp

2040 Design Year - Build 8 Lanes

Timing Plan: PM Peak

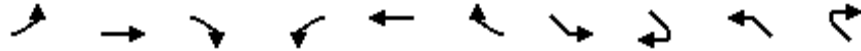

Lane Group	EBL	EBT	EBR2	WBL	WBT	WBR2	SEL	SER2	NWL	NWR2
Total Delay	51.5	36.0	0.5	101.4	30.5	1.7	54.4	51.0	30.8	0.8
LOS	D	D	A	F	C	A	D	D	C	A
Approach Delay	32.2			34.1						
Approach LOS	C			C						
Queue Length 50th (ft)	158	391	0	~183	276	0	312	233	120	0
Queue Length 95th (ft)	#233	#509	0	#286	351	0	#441	#392	167	0
Internal Link Dist (ft)	929			884						
Turn Bay Length (ft)	450		300	350		300		425	675	575
Base Capacity (vph)	613	1450	1487	474	1362	1562	1021	466	996	1599
Starvation Cap Reductn	0	0	0	0	0	0	0	0	0	0
Spillback Cap Reductn	0	0	0	0	0	0	0	0	0	0
Storage Cap Reductn	0	0	0	0	0	0	0	0	0	0
Reduced v/c Ratio	0.81	0.89	0.31	1.06	0.72	0.60	0.95	0.84	0.45	0.41

Intersection Summary

Area Type: Other
 Cycle Length: 100
 Actuated Cycle Length: 100
 Offset: 0 (0%), Referenced to phase 2:EBT and 6:WBT, Start of Green
 Natural Cycle: 90
 Control Type: Actuated-Coordinated
 Maximum v/c Ratio: 1.06
 Intersection Signal Delay: 33.9
 Intersection LOS: C
 Intersection Capacity Utilization 82.5%
 ICU Level of Service E
 Analysis Period (min) 15
 ~ Volume exceeds capacity, queue is theoretically infinite.
 Queue shown is maximum after two cycles.
 # 95th percentile volume exceeds capacity, queue may be longer.
 Queue shown is maximum after two cycles.

Splits and Phases: 1: NC 146 (Long Shoals Rd) & I-26 NB On-Ramp

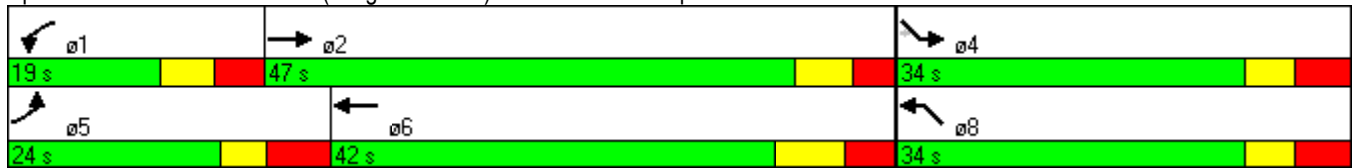

Lanes, Volumes, Timings
 2: I-26 NB On-Ramp & US 25 (Asheville Highway)

2040 Design Year - Build 8 Lanes

Timing Plan: PM Peak



Lane Group	EBL	EBT	EBR	WBL	WBT	WBR	NBL	NBT	NBR	SBL	SBT	SBR
Lane Configurations				↙		↗↗	↙	↗↗			↗↗	↗
Volume (vph)	0	0	0	228	0	652	903	1397	0	0	1361	319
Ideal Flow (vphpl)	1900	1900	1900	1900	1900	1900	1900	1900	1900	1900	1900	1900
Grade (%)		0%			2%			-1%			2%	
Storage Length (ft)	0		0	0		150	0		0	0		300
Storage Lanes	0		0	1		2	1		0	0		1
Taper Length (ft)	100		100	100		100	100		100	100		100
Lane Util. Factor	1.00	1.00	1.00	1.00	1.00	0.88	1.00	0.95	1.00	1.00	0.95	1.00
Frt						0.850						0.850
Flt Protected				0.950			0.950					
Satd. Flow (prot)	0	0	0	1735	0	2706	1680	3489	0	0	3436	1480
Flt Permitted				0.950			0.950					
Satd. Flow (perm)	0	0	0	1735	0	2706	1680	3489	0	0	3436	1480
Right Turn on Red			No			No			No			No
Satd. Flow (RTOR)												
Link Speed (mph)		45			35			45			45	
Link Distance (ft)		533			612			601			596	
Travel Time (s)		8.1			11.9			9.1			9.0	
Peak Hour Factor	0.90	0.90	0.90	0.90	0.90	0.90	0.90	0.90	0.90	0.90	0.90	0.90
Heavy Vehicles (%)	5%	5%	5%	3%	5%	4%	8%	4%	5%	5%	4%	8%
Adj. Flow (vph)	0	0	0	253	0	724	1003	1552	0	0	1512	354
Shared Lane Traffic (%)												
Lane Group Flow (vph)	0	0	0	253	0	724	1003	1552	0	0	1512	354
Turn Type				Prot		custom	Prot					Free
Protected Phases				4			5	2			6	
Permitted Phases						4						Free
Detector Phase				4		4	5	2			6	
Switch Phase												
Minimum Initial (s)				7.0		7.0	7.0	12.0			12.0	
Minimum Split (s)				13.0		13.0	14.0	19.0			18.0	
Total Split (s)	0.0	0.0	0.0	20.0	0.0	20.0	50.0	90.0	0.0	0.0	40.0	0.0
Total Split (%)	0.0%	0.0%	0.0%	18.2%	0.0%	18.2%	45.5%	81.8%	0.0%	0.0%	36.4%	0.0%
Maximum Green (s)				14.0		14.0	43.6	83.9			34.7	
Yellow Time (s)				3.7		3.7	3.0	4.6			4.3	
All-Red Time (s)				2.3		2.3	3.4	1.5			1.0	
Lost Time Adjust (s)	0.0	0.0	-2.0	-2.0	0.0	-2.0	-1.4	-1.1	0.0	-2.0	-0.3	0.0
Total Lost Time (s)	4.0	4.0	2.0	4.0	4.0	4.0	5.0	5.0	4.0	2.0	5.0	4.0
Lead/Lag							Lag				Lead	
Lead-Lag Optimize?							Yes				Yes	
Vehicle Extension (s)				2.0		2.0	2.0	8.0			8.0	
Minimum Gap (s)				3.0		3.0	3.0	5.5			5.5	
Time Before Reduce (s)				0.0		0.0	0.0	15.0			15.0	
Time To Reduce (s)				0.0		0.0	0.0	50.0			50.0	
Recall Mode				None		None	None	C-Max			C-Max	
Act Effct Green (s)				16.0		16.0	45.0	85.0			35.0	110.0
Actuated g/C Ratio				0.15		0.15	0.41	0.77			0.32	1.00
v/c Ratio				1.00		1.84	1.46	0.58			1.38	0.24
Control Delay				105.6		415.5	231.8	7.3			209.9	0.4
Queue Delay				0.0		0.0	4.8	0.7			0.0	0.0

Lanes, Volumes, Timings
 2: I-26 NB On-Ramp & US 25 (Asheville Highway)

2040 Design Year - Build 8 Lanes

Timing Plan: PM Peak



Lane Group	EBL	EBT	EBR	WBL	WBT	WBR	NBL	NBT	NBR	SBL	SBT	SBR
Total Delay				105.6		415.5	236.6	8.0			209.9	0.4
LOS				F		F	F	A			F	A
Approach Delay								97.7			170.1	
Approach LOS								F			F	
Queue Length 50th (ft)				~182		~441	~953	179			~748	0
Queue Length 95th (ft)				#349		#571	m#588	m133			#886	0
Internal Link Dist (ft)		453			532			521			516	
Turn Bay Length (ft)						150						300
Base Capacity (vph)				252		394	687	2696			1093	1480
Starvation Cap Reductn				0		0	5	714			0	0
Spillback Cap Reductn				0		0	0	0			0	0
Storage Cap Reductn				0		0	0	0			0	0
Reduced v/c Ratio				1.00		1.84	1.47	0.78			1.38	0.24

Intersection Summary

Area Type: Other
 Cycle Length: 110
 Actuated Cycle Length: 110
 Offset: 66 (60%), Referenced to phase 2:NBT and 6:SBT, Start of Green
 Natural Cycle: 180
 Control Type: Actuated-Coordinated
 Maximum v/c Ratio: 1.84
 Intersection Signal Delay: 165.7
 Intersection LOS: F
 Intersection Capacity Utilization 113.8%
 ICU Level of Service H
 Analysis Period (min) 15
 ~ Volume exceeds capacity, queue is theoretically infinite.
 Queue shown is maximum after two cycles.
 # 95th percentile volume exceeds capacity, queue may be longer.
 Queue shown is maximum after two cycles.
 m Volume for 95th percentile queue is metered by upstream signal.

Splits and Phases: 2: I-26 NB On-Ramp & US 25 (Asheville Highway)

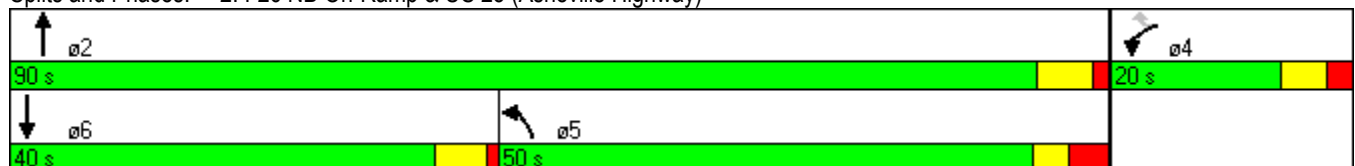

Lanes, Volumes, Timings
3: I-26 SB Off-Ramp & US 25 (Asheville Highway)

2040 Design Year - Build 8 Lanes

Timing Plan: PM Peak



Lane Group	EBL	EBT	EBR	WBL	WBT	WBR	NBL	NBT	NBR	SBL	SBT	SBR
Lane Configurations												
Volume (vph)	326	0	726	0	0	0	0	1974	229	517	1072	0
Ideal Flow (vphpl)	1900	1900	1900	1900	1900	1900	1900	1900	1900	1900	1900	1900
Grade (%)		3%			0%			4%			1%	
Storage Length (ft)	0		100	0		0	0		500	0		0
Storage Lanes	1		1	0		0	0		1	1		0
Taper Length (ft)	100		100	100		100	100		100	100		100
Lane Util. Factor	1.00	1.00	1.00	1.00	1.00	1.00	1.00	0.95	1.00	1.00	0.95	1.00
Frt			0.850						0.850			
Flt Protected	0.950									0.950		
Satd. Flow (prot)	1710	0	1544	0	0	0	0	3435	1465	1663	3487	0
Flt Permitted	0.950									0.950		
Satd. Flow (perm)	1710	0	1544	0	0	0	0	3435	1465	1663	3487	0
Right Turn on Red			Yes			No			No			No
Satd. Flow (RTOR)			94									
Link Speed (mph)		35			45			45			45	
Link Distance (ft)		471			598			795			601	
Travel Time (s)		9.2			9.1			12.0			9.1	
Peak Hour Factor	0.90	0.90	0.90	0.90	0.90	0.90	0.90	0.90	0.90	0.90	0.90	0.90
Heavy Vehicles (%)	4%	5%	3%	5%	5%	5%	5%	3%	8%	8%	3%	5%
Adj. Flow (vph)	362	0	807	0	0	0	0	2193	254	574	1191	0
Shared Lane Traffic (%)												
Lane Group Flow (vph)	362	0	807	0	0	0	0	2193	254	574	1191	0
Turn Type	Prot		custom						Free	Prot		
Protected Phases	4		4					2		1	6	
Permitted Phases									Free			
Detector Phase	4		4					2		1	6	
Switch Phase												
Minimum Initial (s)	7.0		7.0					12.0		7.0	12.0	
Minimum Split (s)	14.0		14.0					19.0		14.0	19.0	
Total Split (s)	35.0	0.0	35.0	0.0	0.0	0.0	0.0	53.0	0.0	22.0	75.0	0.0
Total Split (%)	31.8%	0.0%	31.8%	0.0%	0.0%	0.0%	0.0%	48.2%	0.0%	20.0%	68.2%	0.0%
Maximum Green (s)	29.0		29.0					47.3		15.5	69.3	
Yellow Time (s)	4.0		4.0					4.7		4.0	4.7	
All-Red Time (s)	2.0		2.0					1.0		2.5	1.0	
Lost Time Adjust (s)	-1.0	-2.0	-1.0	-2.0	-2.0	-2.0	-2.0	-0.7	-0.7	-1.5	-1.7	-2.0
Total Lost Time (s)	5.0	2.0	5.0	2.0	2.0	2.0	2.0	5.0	3.3	5.0	4.0	2.0
Lead/Lag								Lead		Lag		
Lead-Lag Optimize?								Yes		Yes		
Vehicle Extension (s)	2.0		2.0					8.0		2.0	8.0	
Minimum Gap (s)	3.0		3.0					5.5		3.0	5.5	
Time Before Reduce (s)	0.0		0.0					15.0		0.0	15.0	
Time To Reduce (s)	0.0		0.0					50.0		0.0	50.0	
Recall Mode	None		None					C-Max		None	C-Max	
Act Effct Green (s)	30.0		30.0					48.0	110.0	17.0	71.0	
Actuated g/C Ratio	0.27		0.27					0.44	1.00	0.15	0.65	
v/c Ratio	0.78		1.65					1.46	0.17	2.23	0.53	
Control Delay	49.8		327.9					239.5	0.3	584.7	29.1	
Queue Delay	1.5		0.0					3.1	0.0	0.0	1.3	

Lanes, Volumes, Timings
 3: I-26 SB Off-Ramp & US 25 (Asheville Highway)

2040 Design Year - Build 8 Lanes

Timing Plan: PM Peak



Lane Group	EBL	EBT	EBR	WBL	WBT	WBR	NBL	NBT	NBR	SBL	SBT	SBR
Total Delay	51.4		327.9					242.6	0.3	584.7	30.4	
LOS	D		F					F	A	F	C	
Approach Delay								217.5			210.6	
Approach LOS								F			F	
Queue Length 50th (ft)	236		~785					~1118	0	~665	410	
Queue Length 95th (ft)	#374		#1025					#1256	0	m#459	m312	
Internal Link Dist (ft)		391			518			715				521
Turn Bay Length (ft)			100						500			
Base Capacity (vph)	466		489					1499	1465	257	2251	
Starvation Cap Reductn	0		0					0	0	0	781	
Spillback Cap Reductn	27		0					7	0	0	0	
Storage Cap Reductn	0		0					0	0	0	0	
Reduced v/c Ratio	0.82		1.65					1.47	0.17	2.23	0.81	

Intersection Summary

Area Type: Other
 Cycle Length: 110
 Actuated Cycle Length: 110
 Offset: 0 (0%), Referenced to phase 2:NBT and 6:SBT, Start of Green
 Natural Cycle: 240
 Control Type: Actuated-Coordinated
 Maximum v/c Ratio: 2.23
 Intersection Signal Delay: 220.6
 Intersection LOS: F
 Intersection Capacity Utilization 113.8%
 ICU Level of Service H
 Analysis Period (min) 15
 ~ Volume exceeds capacity, queue is theoretically infinite.
 Queue shown is maximum after two cycles.
 # 95th percentile volume exceeds capacity, queue may be longer.
 Queue shown is maximum after two cycles.
 m Volume for 95th percentile queue is metered by upstream signal.



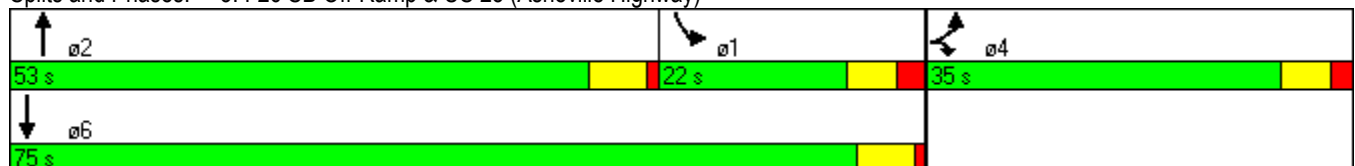





















Splits and Phases: 3: I-26 SB Off-Ramp & US 25 (Asheville Highway)



Lanes, Volumes, Timings
4: I-26 NB Ramps & Balfour Pkwy

2040 Design Year - Build 8 Lanes

Timing Plan: PM Peak

												
Lane Group	EBL	EBT	EBR	WBL	WBT	WBR	NBL	NBT	NBR	SBL	SBT	SBR
Lane Configurations			 			 	 	 			 	 
Volume (vph)	0	0	724	0	0	268	498	1703	0	0	813	804
Ideal Flow (vphpl)	1900	1900	1900	1900	1900	1900	1900	1900	1900	1900	1900	1900
Storage Length (ft)	0		0	0		0	250		0	0		250
Storage Lanes	0		2	0		1	1		0	0		1
Taper Length (ft)	100		100	100		100	100		100	100		100
Lane Util. Factor	1.00	1.00	0.88	1.00	1.00	1.00	1.00	0.95	1.00	1.00	0.95	1.00
Frt			0.850			0.865						0.850
Flt Protected							0.950					
Satd. Flow (prot)	0	0	2787	0	0	1611	1671	3539	0	0	3539	1495
Flt Permitted							0.950					
Satd. Flow (perm)	0	0	2787	0	0	1611	1671	3539	0	0	3539	1495
Right Turn on Red			No			No			No			No
Satd. Flow (RTOR)												
Link Speed (mph)		25			45			45			45	
Link Distance (ft)		393			429			690			522	
Travel Time (s)		10.7			6.5			10.5			7.9	
Peak Hour Factor	0.90	0.90	0.90	0.90	0.90	0.90	0.90	0.90	0.90	0.90	0.90	0.90
Heavy Vehicles (%)	5%	5%	2%	5%	5%	2%	8%	2%	5%	5%	2%	8%
Adj. Flow (vph)	0	0	804	0	0	298	553	1892	0	0	903	893
Shared Lane Traffic (%)												
Lane Group Flow (vph)	0	0	804	0	0	298	553	1892	0	0	903	893
Turn Type			Over			Free	Prot					Perm
Protected Phases			5				5	Free				6
Permitted Phases						Free						6
Detector Phase			5				5					6
Switch Phase												
Minimum Initial (s)			7.0				7.0				12.0	12.0
Minimum Split (s)			14.0				14.0				19.0	19.0
Total Split (s)	0.0	0.0	30.0	0.0	0.0	0.0	30.0	0.0	0.0	0.0	60.0	60.0
Total Split (%)	0.0%	0.0%	33.3%	0.0%	0.0%	0.0%	33.3%	0.0%	0.0%	0.0%	66.7%	66.7%
Maximum Green (s)			23.0				23.0				53.0	53.0
Yellow Time (s)			5.0				5.0				5.0	5.0
All-Red Time (s)			2.0				2.0				2.0	2.0
Lost Time Adjust (s)	-2.0	-2.0	-2.0	-2.0	-2.0	-2.0	-2.0	-2.0	-2.0	-2.0	-2.0	-2.0
Total Lost Time (s)	2.0	2.0	5.0	2.0	2.0	2.0	5.0	2.0	2.0	2.0	5.0	5.0
Lead/Lag			Lead				Lead				Lag	Lag
Lead-Lag Optimize?			Yes				Yes				Yes	Yes
Vehicle Extension (s)			3.0				3.0				3.0	3.0
Recall Mode			None				None				C-Max	C-Max
Act Effct Green (s)			25.0			90.0	25.0	90.0			55.0	55.0
Actuated g/C Ratio			0.28			1.00	0.28	1.00			0.61	0.61
v/c Ratio			1.04			0.18	1.19	0.53			0.42	0.98
Control Delay			76.2			0.3	125.2	0.3			9.9	43.6
Queue Delay			0.0			0.0	0.0	0.0			0.0	0.0
Total Delay			76.2			0.3	125.2	0.3			9.9	43.6
LOS			E			A	F	A			A	D
Approach Delay								28.5			26.6	
Approach LOS								C			C	

Lanes, Volumes, Timings
 4: I-26 NB Ramps & Balfour Pkwy

2040 Design Year - Build 8 Lanes

Timing Plan: PM Peak

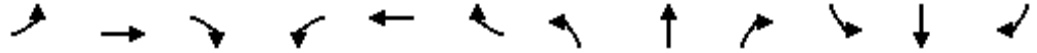

Lane Group	EBL	EBT	EBR	WBL	WBT	WBR	NBL	NBT	NBR	SBL	SBT	SBR
Queue Length 50th (ft)			~282			0	~392	0			128	447
Queue Length 95th (ft)			#408			0	m#503	m0			167	#750
Internal Link Dist (ft)		313			349			610			442	
Turn Bay Length (ft)							250					250
Base Capacity (vph)			774			1611	464	3539			2163	914
Starvation Cap Reductn			0			0	0	0			0	0
Spillback Cap Reductn			0			0	0	0			0	0
Storage Cap Reductn			0			0	0	0			0	0
Reduced v/c Ratio			1.04			0.18	1.19	0.53			0.42	0.98

Intersection Summary

Area Type: Other
 Cycle Length: 90
 Actuated Cycle Length: 90
 Offset: 51 (57%), Referenced to phase 6:SBT, Start of Green
 Natural Cycle: 100
 Control Type: Actuated-Coordinated
 Maximum v/c Ratio: 1.19
 Intersection Signal Delay: 33.5
 Intersection LOS: C
 Intersection Capacity Utilization 85.7%
 ICU Level of Service E
 Analysis Period (min) 15
 ~ Volume exceeds capacity, queue is theoretically infinite.
 Queue shown is maximum after two cycles.
 # 95th percentile volume exceeds capacity, queue may be longer.
 Queue shown is maximum after two cycles.
 m Volume for 95th percentile queue is metered by upstream signal.























Splits and Phases: 4: I-26 NB Ramps & Balfour Pkwy



Lanes, Volumes, Timings
5: I-26 SB Ramps & Balfour Pkwy

2040 Design Year - Build 8 Lanes

Timing Plan: PM Peak

												
Lane Group	EBL	EBT	EBR	WBL	WBT	WBR	NBL	NBT	NBR	SBL	SBT	SBR
Lane Configurations						 		 			 	
Volume (vph)	0	0	377	0	0	847	0	1354	748	199	1338	0
Ideal Flow (vphpl)	1900	1900	1900	1900	1900	1900	1900	1900	1900	1900	1900	1900
Storage Length (ft)	0		0	0		0	0		250	250		0
Storage Lanes	0		1	0		2	0		1	1		0
Taper Length (ft)	100		100	100		100	100		100	100		100
Lane Util. Factor	1.00	1.00	1.00	1.00	1.00	0.88	1.00	0.95	1.00	1.00	0.95	1.00
Frt			0.865			0.850			0.850			
Flt Protected										0.950		
Satd. Flow (prot)	0	0	1611	0	0	2787	0	3539	1495	1671	3539	0
Flt Permitted										0.950		
Satd. Flow (perm)	0	0	1611	0	0	2787	0	3539	1495	1671	3539	0
Right Turn on Red			No			No			No			No
Satd. Flow (RTOR)												
Link Speed (mph)		45			25			45			45	
Link Distance (ft)		642			361			480			690	
Travel Time (s)		9.7			9.8			7.3			10.5	
Peak Hour Factor	0.90	0.90	0.90	0.90	0.90	0.90	0.90	0.90	0.90	0.90	0.90	0.90
Heavy Vehicles (%)	5%	5%	2%	5%	5%	2%	5%	2%	8%	8%	2%	5%
Adj. Flow (vph)	0	0	419	0	0	941	0	1504	831	221	1487	0
Shared Lane Traffic (%)												
Lane Group Flow (vph)	0	0	419	0	0	941	0	1504	831	221	1487	0
Turn Type			Free			Over			Perm	Prot		
Protected Phases						1		2		1	Free	
Permitted Phases			Free						2			
Detector Phase						1		2	2	1		
Switch Phase												
Minimum Initial (s)						7.0		12.0	12.0	7.0		
Minimum Split (s)						14.0		19.0	19.0	14.0		
Total Split (s)	0.0	0.0	0.0	0.0	0.0	35.0	0.0	55.0	55.0	35.0	0.0	0.0
Total Split (%)	0.0%	0.0%	0.0%	0.0%	0.0%	38.9%	0.0%	61.1%	61.1%	38.9%	0.0%	0.0%
Maximum Green (s)						28.0		48.0	48.0	28.0		
Yellow Time (s)						5.0		5.0	5.0	5.0		
All-Red Time (s)						2.0		2.0	2.0	2.0		
Lost Time Adjust (s)	-2.0	-2.0	-2.0	-2.0	-2.0	-2.0	-2.0	-2.0	-2.0	-2.0	-2.0	-2.0
Total Lost Time (s)	2.0	2.0	2.0	2.0	2.0	5.0	2.0	5.0	5.0	5.0	2.0	2.0
Lead/Lag						Lead		Lag	Lag	Lead		
Lead-Lag Optimize?						Yes		Yes	Yes	Yes		
Vehicle Extension (s)						3.0		3.0	3.0	3.0		
Recall Mode						None		C-Max	C-Max	None		
Act Effct Green (s)			90.0			30.0		50.0	50.0	30.0	90.0	
Actuated g/C Ratio			1.00			0.33		0.56	0.56	0.33	1.00	
v/c Ratio			0.26			1.01		0.77	1.00	0.40	0.42	
Control Delay			0.4			64.1		18.8	53.2	18.1	0.3	
Queue Delay			0.0			0.0		0.0	0.0	0.0	0.0	
Total Delay			0.4			64.1		18.8	53.2	18.1	0.3	
LOS			A			E		B	D	B	A	
Approach Delay								31.0			2.6	
Approach LOS								C			A	

Lanes, Volumes, Timings
5: I-26 SB Ramps & Balfour Pkwy

2040 Design Year - Build 8 Lanes

Timing Plan: PM Peak



Lane Group	EBL	EBT	EBR	WBL	WBT	WBR	NBL	NBT	NBR	SBL	SBT	SBR
Queue Length 50th (ft)			0			~309		325	~443	91	0	
Queue Length 95th (ft)			0			#454		414	#720	m114	m0	
Internal Link Dist (ft)		562			281			400				610
Turn Bay Length (ft)									250	250		
Base Capacity (vph)			1611			929		1966	831	557	3539	
Starvation Cap Reductn			0			0		0	0	0	0	
Spillback Cap Reductn			0			0		0	0	0	0	
Storage Cap Reductn			0			0		0	0	0	0	
Reduced v/c Ratio			0.26			1.01		0.77	1.00	0.40	0.42	

Intersection Summary

Area Type: Other
 Cycle Length: 90
 Actuated Cycle Length: 90
 Offset: 0 (0%), Referenced to phase 2:NBT, Start of Green
 Natural Cycle: 90
 Control Type: Actuated-Coordinated
 Maximum v/c Ratio: 1.01
 Intersection Signal Delay: 25.4
 Intersection LOS: C
 Intersection Capacity Utilization 75.4%
 ICU Level of Service D
 Analysis Period (min) 15
 ~ Volume exceeds capacity, queue is theoretically infinite.
 Queue shown is maximum after two cycles.
 # 95th percentile volume exceeds capacity, queue may be longer.
 Queue shown is maximum after two cycles.
 m Volume for 95th percentile queue is metered by upstream signal.

Splits and Phases: 5: I-26 SB Ramps & Balfour Pkwy



Lanes, Volumes, Timings
6: US 64 & SR 1516 (Francis Rd)

2040 Design Year - Build 8 Lanes

Timing Plan: PM Peak



Lane Group	EBL	EBT	EBR	WBL	WBT	WBR	NBL	NBT	NBR	SBL	SBT	SBR
Lane Configurations												
Volume (vph)	158	2258	467	23	1763	8	536	5	33	11	5	182
Ideal Flow (vphpl)	1900	1900	1900	1900	1900	1900	1900	1900	1900	1900	1900	1900
Grade (%)		-1%			4%			-1%			2%	
Storage Length (ft)	150		0	125		0	150		150	0		150
Storage Lanes	1		1	1		0	1		1	0		1
Taper Length (ft)	100		100	100		100	100		100	100		100
Lane Util. Factor	1.00	0.95	1.00	1.00	0.95	0.95	0.95	0.95	1.00	1.00	1.00	1.00
Ped Bike Factor	0.94											
Frt			0.850			0.999				0.850		0.850
Flt Protected	0.950			0.950			0.950	0.953			0.968	
Satd. Flow (prot)	1778	3557	1591	1734	3465	0	1690	1695	1591	0	1785	1567
Flt Permitted	0.950			0.950			0.950	0.953			0.968	
Satd. Flow (perm)	1674	3557	1591	1734	3465	0	1690	1695	1591	0	1785	1567
Right Turn on Red			No			No			No			No
Satd. Flow (RTOR)												
Link Speed (mph)		45			45			35			35	
Link Distance (ft)		836			622			375			406	
Travel Time (s)		12.7			9.4			7.3			7.9	
Confl. Peds. (#/hr)	1700											
Peak Hour Factor	0.90	0.90	0.90	0.90	0.90	0.90	0.90	0.90	0.90	0.90	0.90	0.90
Heavy Vehicles (%)	2%	2%	2%	2%	2%	2%	2%	2%	2%	2%	2%	2%
Adj. Flow (vph)	176	2509	519	26	1959	9	596	6	37	12	6	202
Shared Lane Traffic (%)							50%					
Lane Group Flow (vph)	176	2509	519	26	1968	0	298	304	37	0	18	202
Turn Type	Prot		Perm	Prot			Split		pm+ov	Split		pm+ov
Protected Phases	5	2		1	6		4	4	1	3	3	5
Permitted Phases			2						4			3
Detector Phase	5	2	2	1	6		4	4	1	3	3	5
Switch Phase												
Minimum Initial (s)	7.0	12.0	12.0	7.0	12.0		7.0	7.0	7.0	7.0	7.0	7.0
Minimum Split (s)	13.0	18.0	18.0	13.0	18.0		14.0	14.0	13.0	14.0	14.0	13.0
Total Split (s)	21.0	112.0	112.0	13.0	104.0	0.0	31.0	31.0	13.0	14.0	14.0	21.0
Total Split (%)	12.4%	65.9%	65.9%	7.6%	61.2%	0.0%	18.2%	18.2%	7.6%	8.2%	8.2%	12.4%
Maximum Green (s)	15.4	106.0	106.0	7.6	98.4		24.4	24.4	7.6	7.5	7.5	15.4
Yellow Time (s)	3.2	4.6	4.6	3.0	4.2		3.9	3.9	3.0	3.7	3.7	3.2
All-Red Time (s)	2.4	1.4	1.4	2.4	1.4		2.7	2.7	2.4	2.8	2.8	2.4
Lost Time Adjust (s)	-0.6	-1.0	-1.0	-0.4	-0.6	-2.0	-1.6	-1.6	-0.4	-2.0	-1.5	-0.6
Total Lost Time (s)	5.0	5.0	5.0	5.0	5.0	2.0	5.0	5.0	5.0	4.5	5.0	5.0
Lead/Lag	Lead	Lag	Lag	Lead	Lag		Lag	Lag	Lead	Lead	Lead	Lead
Lead-Lag Optimize?	Yes	Yes	Yes	Yes	Yes		Yes	Yes	Yes	Yes	Yes	Yes
Vehicle Extension (s)	1.0	2.0	2.0	1.0	2.0		1.0	1.0	1.0	1.0	1.0	1.0
Recall Mode	None	C-Max	C-Max	None	C-Max		None	None	None	None	None	None
Act Effct Green (s)	16.0	109.9	109.9	7.6	99.0		31.8	31.8	44.4		8.6	21.2
Actuated g/C Ratio	0.09	0.65	0.65	0.04	0.58		0.19	0.19	0.26		0.05	0.12
v/c Ratio	1.05	1.09	0.50	0.34	0.98		0.94	0.96	0.09		0.20	1.04
Control Delay	157.3	70.2	14.1	90.8	49.2		103.5	106.5	51.4		82.8	135.3
Queue Delay	0.0	0.0	0.0	0.0	0.0		0.0	0.0	0.0		0.0	0.0
Total Delay	157.3	70.2	14.1	90.8	49.2		103.5	106.5	51.4		82.8	135.3

Lanes, Volumes, Timings
6: US 64 & SR 1516 (Francis Rd)

2040 Design Year - Build 8 Lanes

Timing Plan: PM Peak



Lane Group	EBL	EBT	EBR	WBL	WBT	WBR	NBL	NBT	NBR	SBL	SBT	SBR
LOS	F	E	B	F	D		F	F	D		F	F
Approach Delay		65.9			49.7			101.9			131.0	
Approach LOS		E			D			F			F	
Queue Length 50th (ft)	~215	~1673	184	29	1083		~404	~416	33		20	166
Queue Length 95th (ft)	#387	#1793	292	66	#1292		#623	#636	68		50	#309
Internal Link Dist (ft)		756			542			295			326	
Turn Bay Length (ft)	150			125			150		150			150
Base Capacity (vph)	167	2300	1029	82	2018		316	317	419		95	195
Starvation Cap Reductn	0	0	0	0	0		0	0	0		0	0
Spillback Cap Reductn	0	0	0	0	0		0	0	0		0	0
Storage Cap Reductn	0	0	0	0	0		0	0	0		0	0
Reduced v/c Ratio	1.05	1.09	0.50	0.32	0.98		0.94	0.96	0.09		0.19	1.04

Intersection Summary

Area Type: Other
 Cycle Length: 170
 Actuated Cycle Length: 170
 Offset: 33 (19%), Referenced to phase 2:EBT and 6:WBT, Start of Green
 Natural Cycle: 220
 Control Type: Actuated-Coordinated
 Maximum v/c Ratio: 1.09
 Intersection Signal Delay: 66.7
 Intersection LOS: E
 Intersection Capacity Utilization 102.4%
 ICU Level of Service G
 Analysis Period (min) 15
 ~ Volume exceeds capacity, queue is theoretically infinite.
 Queue shown is maximum after two cycles.
 # 95th percentile volume exceeds capacity, queue may be longer.
 Queue shown is maximum after two cycles.

Splits and Phases: 6: US 64 & SR 1516 (Francis Rd)

ø1	ø2	ø3	ø4
13 s	112 s	14 s	31 s
ø5	ø6		
21 s	104 s		

Lanes, Volumes, Timings
7: US 64 & I-26 SB Off-Ramp

2040 Design Year - Build 8 Lanes

Timing Plan: PM Peak

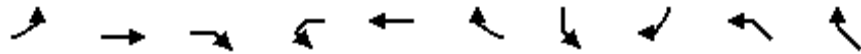

Lane Group	EBL	EBT	EBR	WBL	WBT	WBR	SBL	SBR	NWL	NWR
Lane Configurations		↑↑	↗		↑↑			↖↖		
Volume (vph)	0	2141	348	0	1598	0	0	416	0	0
Ideal Flow (vphpl)	1900	1900	1900	1900	1900	1900	1900	1900	1900	1900
Grade (%)		3%			-3%		-3%		0%	
Storage Length (ft)	0		0	0		0	0	500	0	0
Storage Lanes	0		1	0		0	0	1	0	0
Taper Length (ft)	100		100	100		100	100	100	100	100
Lane Util. Factor	1.00	0.95	1.00	1.00	0.95	1.00	1.00	0.88	1.00	1.00
Frt			0.850					0.850		
Flt Protected										
Satd. Flow (prot)	0	3486	1473	0	3592	0	0	2828	0	0
Flt Permitted										
Satd. Flow (perm)	0	3486	1473	0	3592	0	0	2828	0	0
Right Turn on Red			No			No		No		
Satd. Flow (RTOR)										
Link Speed (mph)		45			45		35		45	
Link Distance (ft)		728			745		807		350	
Travel Time (s)		11.0			11.3		15.7		5.3	
Peak Hour Factor	0.90	0.90	0.90	0.90	0.90	0.90	0.90	0.90	0.90	0.90
Heavy Vehicles (%)	5%	2%	8%	5%	2%	5%	5%	2%	5%	5%
Adj. Flow (vph)	0	2379	387	0	1776	0	0	462	0	0
Shared Lane Traffic (%)										
Lane Group Flow (vph)	0	2379	387	0	1776	0	0	462	0	0
Turn Type			Perm					custom		
Protected Phases		Free			6			4		
Permitted Phases			Free							
Detector Phase					6			4		
Switch Phase										
Minimum Initial (s)					12.0			7.0		
Minimum Split (s)					18.0			13.0		
Total Split (s)	0.0	0.0	0.0	0.0	126.0	0.0	0.0	44.0	0.0	0.0
Total Split (%)	0.0%	0.0%	0.0%	0.0%	74.1%	0.0%	0.0%	25.9%	0.0%	0.0%
Maximum Green (s)					120.2			38.9		
Yellow Time (s)					4.8			4.1		
All-Red Time (s)					1.0			1.0		
Lost Time Adjust (s)	0.0	0.0	0.0	0.0	-0.8	0.0	0.0	-0.1	-2.0	0.0
Total Lost Time (s)	4.0	4.0	4.0	4.0	5.0	4.0	4.0	5.0	2.0	4.0
Lead/Lag										
Lead-Lag Optimize?										
Vehicle Extension (s)					2.0			1.0		
Recall Mode					C-Max			None		
Act Effct Green (s)		170.0	170.0		128.6			31.4		
Actuated g/C Ratio		1.00	1.00		0.76			0.18		
v/c Ratio		0.68	0.26		0.65			0.88		
Control Delay		2.3	0.0		13.5			86.2		
Queue Delay		0.0	0.0		0.1			0.8		
Total Delay		2.3	0.0		13.6			87.0		
LOS		A	A		B			F		
Approach Delay		2.0			13.6					

Lanes, Volumes, Timings
7: US 64 & I-26 SB Off-Ramp

2040 Design Year - Build 8 Lanes

Timing Plan: PM Peak

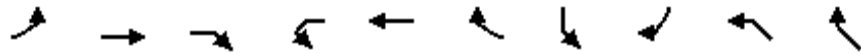

Lane Group	EBL	EBT	EBR	WBL	WBT	WBR	SBL	SBR	NWL	NWR
Approach LOS		A			B					
Queue Length 50th (ft)		34	0		438			288		
Queue Length 95th (ft)		m0	m0		m654			347		
Internal Link Dist (ft)		648			665		727		270	
Turn Bay Length (ft)								500		
Base Capacity (vph)		3486	1473		2717			649		
Starvation Cap Reductn		0	0		0			0		
Spillback Cap Reductn		0	0		96			43		
Storage Cap Reductn		0	0		0			0		
Reduced v/c Ratio		0.68	0.26		0.68			0.76		

Intersection Summary

Area Type: Other
 Cycle Length: 170
 Actuated Cycle Length: 170
 Offset: 0 (0%), Referenced to phase 6:WBT, Start of Green, Master Intersection
 Natural Cycle: 60
 Control Type: Actuated-Coordinated
 Maximum v/c Ratio: 0.88
 Intersection Signal Delay: 14.0
 Intersection LOS: B
 Intersection Capacity Utilization 110.6%
 ICU Level of Service H
 Analysis Period (min) 15
 m Volume for 95th percentile queue is metered by upstream signal.

Splits and Phases: 7: US 64 & I-26 SB Off-Ramp



Lanes, Volumes, Timings
8: US 64 & SR 1634 (Carolina Village Rd)

2040 Design Year - Build 8 Lanes

Timing Plan: PM Peak



Lane Group	EBL	EBT	EBR	WBL	WBT	WBR	NBL	NBT	NBR	SBL	SBT	SBR
Lane Configurations												
Volume (vph)	94	1999	77	189	1606	243	81	5	248	213	5	66
Ideal Flow (vphpl)	1900	1900	1900	1900	1900	1900	1900	1900	1900	1900	1900	1900
Grade (%)		1%			-3%			3%				-1%
Storage Length (ft)	100		0	100		0	0		0	0		150
Storage Lanes	1		0	1		1	0		0	0		1
Taper Length (ft)	100		100	100		100	100		100	100		100
Lane Util. Factor	1.00	0.95	0.95	1.00	0.95	1.00	1.00	1.00	1.00	1.00	1.00	1.00
Frt		0.994				0.850		0.900				0.850
Flt Protected	0.950			0.950				0.988			0.954	
Satd. Flow (prot)	1761	3500	0	1796	3592	1607	0	1632	0	0	1786	1591
Flt Permitted	0.950			0.950				0.618			0.372	
Satd. Flow (perm)	1761	3500	0	1796	3592	1607	0	1021	0	0	696	1591
Right Turn on Red			No			No			No			No
Satd. Flow (RTOR)												
Link Speed (mph)		45			45			30			30	
Link Distance (ft)		560			728			219			359	
Travel Time (s)		8.5			11.0			5.0			8.2	
Peak Hour Factor	0.90	0.90	0.90	0.90	0.90	0.90	0.90	0.90	0.90	0.90	0.90	0.90
Heavy Vehicles (%)	2%	2%	2%	2%	2%	2%	2%	2%	2%	2%	2%	2%
Adj. Flow (vph)	104	2221	86	210	1784	270	90	6	276	237	6	73
Shared Lane Traffic (%)												
Lane Group Flow (vph)	104	2307	0	210	1784	270	0	372	0	0	243	73
Turn Type	Prot			Prot		Perm	Perm			Perm		pm+ov
Protected Phases	5	2		1	6			8			4	5
Permitted Phases						6	8			4		4
Detector Phase	5	2		1	6	6	8	8		4	4	5
Switch Phase												
Minimum Initial (s)	7.0	12.0		7.0	12.0	12.0	7.0	7.0		7.0	7.0	7.0
Minimum Split (s)	13.0	18.0		13.0	19.0	19.0	13.0	13.0		13.0	13.0	13.0
Total Split (s)	16.0	96.0	0.0	20.0	100.0	100.0	54.0	54.0	0.0	54.0	54.0	16.0
Total Split (%)	9.4%	56.5%	0.0%	11.8%	58.8%	58.8%	31.8%	31.8%	0.0%	31.8%	31.8%	9.4%
Maximum Green (s)	10.1	90.4		14.6	93.8	93.8	48.2	48.2		48.1	48.1	10.1
Yellow Time (s)	3.0	4.4		3.0	4.8	4.8	3.4	3.4		3.6	3.6	3.0
All-Red Time (s)	2.9	1.2		2.4	1.4	1.4	2.4	2.4		2.3	2.3	2.9
Lost Time Adjust (s)	-0.9	-0.6	-2.0	-0.4	-1.2	-1.2	-2.0	-0.8	-2.0	-2.0	-0.9	-0.9
Total Lost Time (s)	5.0	5.0	2.0	5.0	5.0	5.0	3.8	5.0	2.0	3.9	5.0	5.0
Lead/Lag	Lag	Lag		Lead	Lead	Lead						Lag
Lead-Lag Optimize?	Yes	Yes		Yes	Yes	Yes						Yes
Vehicle Extension (s)	1.0	2.0		1.0	2.0	2.0	1.0	1.0		1.0	1.0	1.0
Recall Mode	None	C-Max		None	C-Max	C-Max	None	None		None	None	None
Act Effct Green (s)	11.0	91.0		15.0	95.0	95.0		49.0			49.0	65.0
Actuated g/C Ratio	0.06	0.54		0.09	0.56	0.56		0.29			0.29	0.38
v/c Ratio	0.91	1.23		1.33	0.89	0.30		1.27			1.21	0.12
Control Delay	139.6	144.1		233.5	29.4	15.3		191.0			180.6	34.7
Queue Delay	0.0	0.0		0.0	6.6	0.0		0.0			0.0	0.0
Total Delay	139.6	144.1		233.5	36.0	15.3		191.0			180.6	34.7
LOS	F	F		F	D	B		F			F	C
Approach Delay		143.9			51.8			191.0			146.9	

Lanes, Volumes, Timings
 8: US 64 & SR 1634 (Carolina Village Rd)

2040 Design Year - Build 8 Lanes

Timing Plan: PM Peak



Lane Group	EBL	EBT	EBR	WBL	WBT	WBR	NBL	NBT	NBR	SBL	SBT	SBR
Approach LOS		F			D			F			F	
Queue Length 50th (ft)	117	~1663		~300	690	111	~519			~329	53	
Queue Length 95th (ft)	#245	#1781		#484	756	178	#735			#518	93	
Internal Link Dist (ft)		480			648		139			279		
Turn Bay Length (ft)	100				100							150
Base Capacity (vph)	114	1874		158	2007	898	294			201	608	
Starvation Cap Reductn	0	0		0	196	0	0			0	0	
Spillback Cap Reductn	0	0		0	0	0	0			0	0	
Storage Cap Reductn	0	0		0	0	0	0			0	0	
Reduced v/c Ratio	0.91	1.23		1.33	0.99	0.30	1.27			1.21	0.12	

Intersection Summary

Area Type: Other
 Cycle Length: 170
 Actuated Cycle Length: 170
 Offset: 158 (93%), Referenced to phase 2:EBT and 6:WBT, Start of Green
 Natural Cycle: 160
 Control Type: Actuated-Coordinated
 Maximum v/c Ratio: 1.33
 Intersection Signal Delay: 108.5 Intersection LOS: F
 Intersection Capacity Utilization 116.9% ICU Level of Service H
 Analysis Period (min) 15
 ~ Volume exceeds capacity, queue is theoretically infinite.
 Queue shown is maximum after two cycles.
 # 95th percentile volume exceeds capacity, queue may be longer.
 Queue shown is maximum after two cycles.

Splits and Phases: 8: US 64 & SR 1634 (Carolina Village Rd)



Lanes, Volumes, Timings
9: SR 1783 (Upward Rd) & I-26 NB On-Ramp

2040 Design Year - Build 8 Lanes

Timing Plan: PM Peak



Lane Group	EBL	EBT	EBR	WBL	WBT	WBR	NBL	NBT	NBR	SBL	SBT	SBR
Lane Configurations	↖↗	↕			↕↖		↖	↕	↗			
Volume (vph)	849	692	0	0	529	163	493	0	165	0	0	0
Ideal Flow (vphpl)	1900	1900	1900	1900	1900	1900	1900	1900	1900	1900	1900	1900
Grade (%)		-3%			3%			4%			0%	
Storage Length (ft)	275		0	0		0	250		175	0		0
Storage Lanes	1		0	0		0	1		1	0		0
Taper Length (ft)	100		100	100		100	100		100	100		100
Lane Util. Factor	0.97	0.95	1.00	1.00	0.95	0.95	0.95	0.95	1.00	1.00	1.00	1.00
Frt					0.965				0.850			
Flt Protected	0.950						0.950	0.950				
Satd. Flow (prot)	3291	3592	0	0	3341	0	1648	1648	1552	0	0	0
Flt Permitted	0.950						0.950	0.950				
Satd. Flow (perm)	3291	3592	0	0	3341	0	1648	1648	1552	0	0	0
Right Turn on Red			No			No			No			No
Satd. Flow (RTOR)												
Link Speed (mph)		45			45			35			45	
Link Distance (ft)		630			322			532			658	
Travel Time (s)		9.5			4.9			10.4			10.0	
Peak Hour Factor	0.90	0.90	0.90	0.90	0.90	0.90	0.90	0.90	0.90	0.90	0.90	0.90
Heavy Vehicles (%)	8%	2%	5%	5%	2%	5%	2%	2%	2%	5%	5%	5%
Adj. Flow (vph)	943	769	0	0	588	181	548	0	183	0	0	0
Shared Lane Traffic (%)							50%					
Lane Group Flow (vph)	943	769	0	0	769	0	274	274	183	0	0	0
Turn Type	Prot						Split		Prot			
Protected Phases	5	2			6		8	8	8			
Permitted Phases												
Detector Phase	5	2			6		8	8	8			
Switch Phase												
Minimum Initial (s)	7.0	14.0			14.0		7.0	7.0	7.0			
Minimum Split (s)	14.0	22.0			21.0		19.0	19.0	19.0			
Total Split (s)	33.0	66.0	0.0	0.0	33.0	0.0	24.0	24.0	24.0	0.0	0.0	0.0
Total Split (%)	36.7%	73.3%	0.0%	0.0%	36.7%	0.0%	26.7%	26.7%	26.7%	0.0%	0.0%	0.0%
Maximum Green (s)	26.7	59.8			27.4		17.9	17.9	17.9			
Yellow Time (s)	3.0	5.1			4.6		3.6	3.6	3.6			
All-Red Time (s)	3.3	1.1			1.0		2.5	2.5	2.5			
Lost Time Adjust (s)	-1.3	-1.2	0.0	0.0	-0.6	0.0	-1.1	-1.1	-1.1	-2.0	0.0	0.0
Total Lost Time (s)	5.0	5.0	4.0	4.0	5.0	4.0	5.0	5.0	5.0	2.0	4.0	4.0
Lead/Lag	Lag				Lead							
Lead-Lag Optimize?	Yes				Yes							
Vehicle Extension (s)	2.0	2.0			2.0		2.0	2.0	2.0			
Minimum Gap (s)	3.0	3.1			3.1		3.0	3.0	3.0			
Time Before Reduce (s)	0.0	15.0			15.0		0.0	0.0	0.0			
Time To Reduce (s)	0.0	45.0			45.0		0.0	0.0	0.0			
Recall Mode	None	C-Max			C-Max		None	None	None			
Act Effct Green (s)	28.0	62.2			29.2		17.8	17.8	17.8			
Actuated g/C Ratio	0.31	0.69			0.32		0.20	0.20	0.20			
v/c Ratio	0.92	0.31			0.71		0.84	0.84	0.60			
Control Delay	30.2	2.2			31.4		57.9	57.9	41.3			
Queue Delay	0.0	0.0			0.0		0.0	0.0	0.0			

Lanes, Volumes, Timings
 9: SR 1783 (Upward Rd) & I-26 NB On-Ramp

2040 Design Year - Build 8 Lanes

Timing Plan: PM Peak



Lane Group	EBL	EBT	EBR	WBL	WBT	WBR	NBL	NBT	NBR	SBL	SBT	SBR
Total Delay	30.2	2.2			31.4		57.9	57.9	41.3			
LOS	C	A			C		E	E	D			
Approach Delay		17.6			31.4			53.7				
Approach LOS		B			C			D				
Queue Length 50th (ft)	273	26			204		155	155	94			
Queue Length 95th (ft)	#389	32			272		#285	#285	162			
Internal Link Dist (ft)		550			242			452			578	
Turn Bay Length (ft)	275						250		175			
Base Capacity (vph)	1024	2483			1084		348	348	328			
Starvation Cap Reductn	0	0			0		0	0	0			
Spillback Cap Reductn	0	0			0		0	0	0			
Storage Cap Reductn	0	0			0		0	0	0			
Reduced v/c Ratio	0.92	0.31			0.71		0.79	0.79	0.56			

Intersection Summary

Area Type: Other
 Cycle Length: 90
 Actuated Cycle Length: 90
 Offset: 80 (89%), Referenced to phase 2:EBT and 6:WBT, Start of Green
 Natural Cycle: 65
 Control Type: Actuated-Coordinated
 Maximum v/c Ratio: 0.92
 Intersection Signal Delay: 29.1
 Intersection LOS: C
 Intersection Capacity Utilization 70.2%
 ICU Level of Service C
 Analysis Period (min) 15
 # 95th percentile volume exceeds capacity, queue may be longer.
 Queue shown is maximum after two cycles.

Splits and Phases: 9: SR 1783 (Upward Rd) & I-26 NB On-Ramp

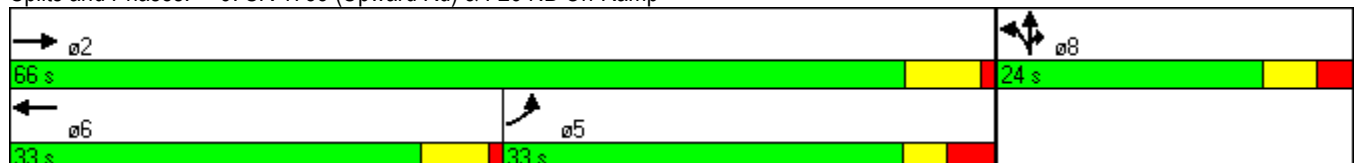

Lanes, Volumes, Timings
 10: SR 1783 (Upward Rd) & I-26 SB Off-Ramp

2040 Design Year - Build 8 Lanes

Timing Plan: PM Peak



Lane Group	EBL	EBT	EBR	WBL	WBT	WBR	NBL	NBT	NBR	SBL	SBT	SBR
Lane Configurations		↑↑↑	↗	↘	↑↑						↖	↗↗
Volume (vph)	0	1373	506	129	893	0	0	0	0	168	0	664
Ideal Flow (vphpl)	1900	1900	1900	1900	1900	1900	1900	1900	1900	1900	1900	1900
Grade (%)		4%			-4%			0%			5%	
Storage Length (ft)	275		0	150		0	0		0	250		0
Storage Lanes	1		1	1		0	0		0	1		2
Taper Length (ft)	100		100	100		100	100		100	100		100
Lane Util. Factor	1.00	0.91	1.00	1.00	0.95	1.00	1.00	1.00	1.00	1.00	1.00	0.88
Frt			0.850									0.850
Flt Protected				0.950							0.950	
Satd. Flow (prot)	0	4984	1465	1705	3610	0	0	0	0	0	1725	2717
Flt Permitted				0.087							0.950	
Satd. Flow (perm)	0	4984	1465	156	3610	0	0	0	0	0	1725	2717
Right Turn on Red			No			No			No			No
Satd. Flow (RTOR)												
Link Speed (mph)		45			45			45			35	
Link Distance (ft)		549			630			547			651	
Travel Time (s)		8.3			9.5			8.3			12.7	
Peak Hour Factor	0.90	0.90	0.90	0.90	0.90	0.90	0.90	0.90	0.90	0.90	0.90	0.90
Heavy Vehicles (%)	5%	2%	8%	8%	2%	5%	5%	5%	5%	2%	2%	2%
Adj. Flow (vph)	0	1526	562	143	992	0	0	0	0	187	0	738
Shared Lane Traffic (%)												
Lane Group Flow (vph)	0	1526	562	143	992	0	0	0	0	0	187	738
Turn Type			Perm		pm+pt					Split		Prot
Protected Phases		2		1	6					4	4	4
Permitted Phases			2		6							
Detector Phase		2		2	1		6			4	4	4
Switch Phase												
Minimum Initial (s)		14.0	14.0	7.0	14.0					7.0	7.0	7.0
Minimum Split (s)		20.0	20.0	14.0	21.0					13.0	13.0	13.0
Total Split (s)	0.0	46.0	46.0	14.0	60.0	0.0	0.0	0.0	0.0	30.0	30.0	30.0
Total Split (%)	0.0%	51.1%	51.1%	15.6%	66.7%	0.0%	0.0%	0.0%	0.0%	33.3%	33.3%	33.3%
Maximum Green (s)		40.4	40.4	7.6	53.6					24.1	24.1	24.1
Yellow Time (s)		4.5	4.5	3.0	5.2					3.6	3.6	3.6
All-Red Time (s)		1.1	1.1	3.4	1.2					2.3	2.3	2.3
Lost Time Adjust (s)	0.0	-0.6	-0.6	-1.4	-1.4	-2.0	0.0	0.0	0.0	-2.0	-0.9	-0.9
Total Lost Time (s)	4.0	5.0	5.0	5.0	5.0	2.0	4.0	4.0	4.0	3.9	5.0	5.0
Lead/Lag		Lag		Lag	Lead							
Lead-Lag Optimize?		Yes		Yes	Yes							
Vehicle Extension (s)		2.0	2.0	2.0	2.0					2.0	2.0	2.0
Minimum Gap (s)		3.1	3.1	3.0	3.1					3.0	3.0	3.0
Time Before Reduce (s)		15.0	15.0	0.0	15.0					0.0	0.0	0.0
Time To Reduce (s)		45.0	45.0	0.0	45.0					0.0	0.0	0.0
Recall Mode		C-Max		C-Max	None		C-Max			None	None	None
Act Effct Green (s)		41.2	41.2	55.0	55.0						25.0	25.0
Actuated g/C Ratio		0.46	0.46	0.61	0.61						0.28	0.28
v/c Ratio		0.67	0.84	0.58	0.45						0.39	0.98
Control Delay		20.9	34.9	19.2	4.8						29.3	61.4
Queue Delay		0.0	0.0	0.0	0.0						0.0	0.0

Lanes, Volumes, Timings
 10: SR 1783 (Upward Rd) & I-26 SB Off-Ramp

2040 Design Year - Build 8 Lanes

Timing Plan: PM Peak



Lane Group	EBL	EBT	EBR	WBL	WBT	WBR	NBL	NBT	NBR	SBL	SBT	SBR
Total Delay		20.9	34.9	19.2	4.8						29.3	61.4
LOS		C	C	B	A						C	E
Approach Delay		24.7			6.6						54.9	
Approach LOS		C			A						D	
Queue Length 50th (ft)		241	272	18	152						86	235
Queue Length 95th (ft)		292	#471	m29	182						146	#367
Internal Link Dist (ft)		469			550			467			571	
Turn Bay Length (ft)				150								
Base Capacity (vph)		2284	671	250	2206						479	755
Starvation Cap Reductn		0	0	0	0						0	0
Spillback Cap Reductn		0	0	0	0						0	0
Storage Cap Reductn		0	0	0	0						0	0
Reduced v/c Ratio		0.67	0.84	0.57	0.45						0.39	0.98

Intersection Summary

Area Type: Other
 Cycle Length: 90
 Actuated Cycle Length: 90
 Offset: 0 (0%), Referenced to phase 2:EBT and 6:WBTL, Start of Green
 Natural Cycle: 90
 Control Type: Actuated-Coordinated
 Maximum v/c Ratio: 0.98
 Intersection Signal Delay: 26.5
 Intersection LOS: C
 Intersection Capacity Utilization 70.2%
 ICU Level of Service C
 Analysis Period (min) 15
 # 95th percentile volume exceeds capacity, queue may be longer.
 Queue shown is maximum after two cycles.
 m Volume for 95th percentile queue is metered by upstream signal.

Splits and Phases: 10: SR 1783 (Upward Rd) & I-26 SB Off-Ramp



Appendix E – Highway Capacity Software Analysis
Output

2011 No-Build

TWO-WAY STOP CONTROL SUMMARY									
General Information				Site Information					
Analyst	JEC			Intersection	11				
Agency/Co.	HNTB North Carolina, PC			Jurisdiction	Polk County				
Date Performed	3/15/2013			Analysis Year	2011 Base Year - No Build				
Analysis Time Period	2011 AM Peak								
Project Description STIP I4400/I-4700 - I-26 Widening									
East/West Street: SR 1142 (Holbert Cove Rd)				North/South Street: I-26 SB Ramps					
Intersection Orientation: East-West				Study Period (hrs): 0.25					
Vehicle Volumes and Adjustments									
Major Street		Eastbound			Westbound				
Movement	1	2	3	4	5	6			
	L	T	R	L	T	R			
Volume (veh/h)	126	57			32	37			
Peak-Hour Factor, PHF	0.90	0.90	1.00	1.00	0.90	0.90			
Hourly Flow Rate, HFR (veh/h)	140	63	0	0	35	41			
Percent Heavy Vehicles	5	--	--	0	--	--			
Median Type	Undivided								
RT Channelized			0					0	
Lanes	0	1	0	0	1	1			
Configuration	LT				T	R			
Upstream Signal		0			0				
Minor Street		Northbound			Southbound				
Movement	7	8	9	10	11	12			
	L	T	R	L	T	R			
Volume (veh/h)	63	0	29						
Peak-Hour Factor, PHF	0.90	0.90	0.90	1.00	1.00	1.00			
Hourly Flow Rate, HFR (veh/h)	70	0	32	0	0	0			
Percent Heavy Vehicles	5	5	5	5	0	0			
Percent Grade (%)	0			0					
Flared Approach		N			N				
Storage		0			0				
RT Channelized			0					0	
Lanes	1	1	1	0	0	0			
Configuration	L	T	R						
Delay, Queue Length, and Level of Service									
Approach	Eastbound	Westbound	Northbound			Southbound			
Movement	1	4	7	8	9	10	11	12	
Lane Configuration	LT		L	T	R				
v (veh/h)	140		70	0	32				
C (m) (veh/h)	1504		545	471	993				
v/c	0.09		0.13	0.00	0.03				
95% queue length	0.31		0.44	0.00	0.10				
Control Delay (s/veh)	7.6		12.6	12.6	8.7				
LOS	A		B	B	A				
Approach Delay (s/veh)	--	--	11.4						
Approach LOS	--	--	B						

TWO-WAY STOP CONTROL SUMMARY								
General Information				Site Information				
Analyst	JEC			Intersection	11			
Agency/Co.	HNTB North Carolina, PC			Jurisdiction	Polk County			
Date Performed	3/15/2013			Analysis Year	2011 Base Year - No Build			
Analysis Time Period	PM Peak							
Project Description STIP I4400/I-4700 - I-26 Widening								
East/West Street: SR 1142 (Holbert Cove Rd)				North/South Street: I-26 NB Ramps				
Intersection Orientation: East-West				Study Period (hrs): 0.25				
Vehicle Volumes and Adjustments								
Major Street	Eastbound			Westbound				
Movement	1	2	3	4	5	6		
	L	T	R	L	T	R		
Volume (veh/h)	95	42			37	49		
Peak-Hour Factor, PHF	0.90	0.90	1.00	1.00	0.90	0.90		
Hourly Flow Rate, HFR (veh/h)	105	46	0	0	41	54		
Percent Heavy Vehicles	5	--	--	0	--	--		
Median Type	Undivided							
RT Channelized			0				0	
Lanes	0	1	0	0	1	1		
Configuration	LT				T	R		
Upstream Signal		0			0			
Minor Street	Northbound			Southbound				
Movement	7	8	9	10	11	12		
	L	T	R	L	T	R		
Volume (veh/h)	103	0	27					
Peak-Hour Factor, PHF	0.90	0.90	0.90	1.00	1.00	1.00		
Hourly Flow Rate, HFR (veh/h)	114	0	30	0	0	0		
Percent Heavy Vehicles	5	5	5	5	0	0		
Percent Grade (%)	0			0				
Flared Approach		N			N			
Storage		0			0			
RT Channelized			0				0	
Lanes	1	1	1	0	0	0		
Configuration	L	T	R					
Delay, Queue Length, and Level of Service								
Approach	Eastbound	Westbound	Northbound			Southbound		
Movement	1	4	7	8	9	10	11	12
Lane Configuration	LT		L	T	R			
v (veh/h)	105		114	0	30			
C (m) (veh/h)	1480		617	528	1015			
v/c	0.07		0.18	0.00	0.03			
95% queue length	0.23		0.67	0.00	0.09			
Control Delay (s/veh)	7.6		12.2	11.8	8.7			
LOS	A		B	B	A			
Approach Delay (s/veh)	--	--	11.4					
Approach LOS	--	--	B					

TWO-WAY STOP CONTROL SUMMARY								
General Information				Site Information				
Analyst	JEC			Intersection	12			
Agency/Co.	HNTB North Carolina, PC			Jurisdiction	Polk County			
Date Performed	3/15/2013			Analysis Year	2011 Base Year - No Build			
Analysis Time Period	2011 AM Peak							
Project Description STIP I4400/I-4700 - I-26 Widening								
East/West Street: SR 1142 (Holbert Cove Rd)				North/South Street: I-26 SB Ramps				
Intersection Orientation: East-West				Study Period (hrs): 0.25				
Vehicle Volumes and Adjustments								
Major Street		Eastbound			Westbound			
Movement	1	2	3	4	5	6		
	L	T	R	L	T	R		
Volume (veh/h)		134	103	27	68			
Peak-Hour Factor, PHF	0.90	0.90	0.90	0.90	0.90	0.90		
Hourly Flow Rate, HFR (veh/h)	0	148	114	30	75	0		
Percent Heavy Vehicles	0	--	--	5	--	--		
Median Type	Undivided							
RT Channelized			0					0
Lanes	0	1	1	0	1	0		
Configuration		T	R	LT				
Upstream Signal		0			0			
Minor Street		Northbound			Southbound			
Movement	7	8	9	10	11	12		
	L	T	R	L	T	R		
Volume (veh/h)				49		95		
Peak-Hour Factor, PHF	0.90	0.90	0.90	0.90	0.90	0.90		
Hourly Flow Rate, HFR (veh/h)	0	0	0	54	0	105		
Percent Heavy Vehicles	0	0	0	5	5	5		
Percent Grade (%)		0			0			
Flared Approach		N			N			
Storage		0			0			
RT Channelized			0					0
Lanes	0	0	0	1	0	1		
Configuration				L		R		
Delay, Queue Length, and Level of Service								
Approach	Eastbound	Westbound	Northbound			Southbound		
Movement	1	4	7	8	9	10	11	12
Lane Configuration		LT				L		R
v (veh/h)		30				54		105
C (m) (veh/h)		1285				635		978
v/c		0.02				0.09		0.11
95% queue length		0.07				0.28		0.36
Control Delay (s/veh)		7.9				11.2		9.1
LOS		A				B		A
Approach Delay (s/veh)	--	--				9.8		
Approach LOS	--	--				A		

TWO-WAY STOP CONTROL SUMMARY								
General Information				Site Information				
Analyst	JEC			Intersection	12			
Agency/Co.	HNTB North Carolina, PC			Jurisdiction	Polk County			
Date Performed	3/15/2013			Analysis Year	2011 Base Year - No Build			
Analysis Time Period	2011 PM Peak							
Project Description STIP I4400/I-4700 - I-26 Widening								
East/West Street: SR 1142 (Holbert Cove Rd)				North/South Street: I-26 SB Ramps				
Intersection Orientation: East-West				Study Period (hrs): 0.25				
Vehicle Volumes and Adjustments								
Major Street		Eastbound			Westbound			
Movement	1	2	3	4	5	6		
	L	T	R	L	T	R		
Volume (veh/h)		100	63	29	111			
Peak-Hour Factor, PHF	0.90	0.90	0.90	0.90	0.90	0.90		
Hourly Flow Rate, HFR (veh/h)	0	111	70	32	123	0		
Percent Heavy Vehicles	0	--	--	5	--	--		
Median Type	Undivided							
RT Channelized			0			0		
Lanes	0	1	1	0	1	0		
Configuration		T	R	LT				
Upstream Signal		0			0			
Minor Street		Northbound			Southbound			
Movement	7	8	9	10	11	12		
	L	T	R	L	T	R		
Volume (veh/h)				37	0	126		
Peak-Hour Factor, PHF	0.90	0.90	0.90	0.90	0.90	0.90		
Hourly Flow Rate, HFR (veh/h)	0	0	0	41	0	140		
Percent Heavy Vehicles	0	0	0	5	5	5		
Percent Grade (%)		0			0			
Flared Approach		N			N			
Storage		0			0			
RT Channelized			0			0		
Lanes	0	0	0	1	1	1		
Configuration				L	T	R		
Delay, Queue Length, and Level of Service								
Approach	Eastbound	Westbound	Northbound			Southbound		
Movement	1	4	7	8	9	10	11	12
Lane Configuration		LT				L	T	R
v (veh/h)		32				41	0	140
C (m) (veh/h)		1376				641	542	920
v/c		0.02				0.06	0.00	0.15
95% queue length		0.07				0.20	0.00	0.54
Control Delay (s/veh)		7.7				11.0	11.6	9.6
LOS		A				B	B	A
Approach Delay (s/veh)	--	--				9.9		
Approach LOS	--	--				A		

2011 Build 6 Lane

TWO-WAY STOP CONTROL SUMMARY								
General Information				Site Information				
Analyst	JEC			Intersection	11			
Agency/Co.	HNTB North Carolina, PC			Jurisdiction	Polk County			
Date Performed	3/15/2013			Analysis Year	2011 Base Year - 6 Lane			
Analysis Time Period	2011 AM Peak							
Project Description STIP I4400/I-4700 - I-26 Widening								
East/West Street: SR 1142 (Holbert Cove Rd)				North/South Street: I-26 SB Ramps				
Intersection Orientation: East-West				Study Period (hrs): 0.25				
Vehicle Volumes and Adjustments								
Major Street	Eastbound			Westbound				
Movement	1	2	3	4	5	6		
	L	T	R	L	T	R		
Volume (veh/h)	126	57			32	37		
Peak-Hour Factor, PHF	0.90	0.90	1.00	1.00	0.90	0.90		
Hourly Flow Rate, HFR (veh/h)	140	63	0	0	35	41		
Percent Heavy Vehicles	5	--	--	0	--	--		
Median Type	Undivided							
RT Channelized			0			0		
Lanes	0	1	0	0	1	1		
Configuration	LT				T	R		
Upstream Signal		0			0			
Minor Street	Northbound			Southbound				
Movement	7	8	9	10	11	12		
	L	T	R	L	T	R		
Volume (veh/h)	63	0	29					
Peak-Hour Factor, PHF	0.90	0.90	0.90	1.00	1.00	1.00		
Hourly Flow Rate, HFR (veh/h)	70	0	32	0	0	0		
Percent Heavy Vehicles	5	5	5	5	0	0		
Percent Grade (%)	0			0				
Flared Approach		N			N			
Storage		0			0			
RT Channelized			0			0		
Lanes	1	1	1	0	0	0		
Configuration	L	T	R					
Delay, Queue Length, and Level of Service								
Approach	Eastbound	Westbound	Northbound			Southbound		
Movement	1	4	7	8	9	10	11	12
Lane Configuration	LT		L	T	R			
v (veh/h)	140		70	0	32			
C (m) (veh/h)	1504		545	471	993			
v/c	0.09		0.13	0.00	0.03			
95% queue length	0.31		0.44	0.00	0.10			
Control Delay (s/veh)	7.6		12.6	12.6	8.7			
LOS	A		B	B	A			
Approach Delay (s/veh)	--	--	11.4					
Approach LOS	--	--	B					

TWO-WAY STOP CONTROL SUMMARY								
General Information					Site Information			
Analyst	JEC				Intersection	11		
Agency/Co.	HNTB North Carolina, PC				Jurisdiction	Polk County		
Date Performed	3/15/2013				Analysis Year	2011 Base Year - 6 Lane		
Analysis Time Period	2011 PM Peak							
Project Description STIP I4400/I-4700 - I-26 Widening								
East/West Street: SR 1142 (Holbert Cove Rd)					North/South Street: I-26 NB Ramps			
Intersection Orientation: East-West					Study Period (hrs): 0.25			
Vehicle Volumes and Adjustments								
Major Street	Eastbound			Westbound				
Movement	1	2	3	4	5	6		
	L	T	R	L	T	R		
Volume (veh/h)	95	42			37	49		
Peak-Hour Factor, PHF	0.90	0.90	1.00	1.00	0.90	0.90		
Hourly Flow Rate, HFR (veh/h)	105	46	0	0	41	54		
Percent Heavy Vehicles	5	--	--	0	--	--		
Median Type	Undivided							
RT Channelized			0				0	
Lanes	0	1	0	0	1	1		
Configuration	LT				T	R		
Upstream Signal		0			0			
Minor Street	Northbound			Southbound				
Movement	7	8	9	10	11	12		
	L	T	R	L	T	R		
Volume (veh/h)	103	0	27					
Peak-Hour Factor, PHF	0.90	0.90	0.90	1.00	1.00	1.00		
Hourly Flow Rate, HFR (veh/h)	114	0	30	0	0	0		
Percent Heavy Vehicles	5	5	5	5	0	0		
Percent Grade (%)		0			0			
Flared Approach		N			N			
Storage		0			0			
RT Channelized			0			0		
Lanes	1	1	1	0	0	0		
Configuration	L	T	R					
Delay, Queue Length, and Level of Service								
Approach	Eastbound	Westbound	Northbound			Southbound		
Movement	1	4	7	8	9	10	11	12
Lane Configuration	LT		L	T	R			
v (veh/h)	105		114	0	30			
C (m) (veh/h)	1480		617	528	1015			
v/c	0.07		0.18	0.00	0.03			
95% queue length	0.23		0.67	0.00	0.09			
Control Delay (s/veh)	7.6		12.2	11.8	8.7			
LOS	A		B	B	A			
Approach Delay (s/veh)	--	--	11.4					
Approach LOS	--	--	B					

TWO-WAY STOP CONTROL SUMMARY

General Information			Site Information					
Analyst	JEC		Intersection	12				
Agency/Co.	HNTB North Carolina, PC		Jurisdiction	Polk County				
Date Performed	3/15/2013		Analysis Year	2011 Base Year - 6 Lane				
Analysis Time Period	2011 AM Peak							
Project Description STIP I4400/I-4700 - I-26 Widening								
East/West Street: SR 1142 (Holbert Cove Rd)			North/South Street: I-26 SB Ramps					
Intersection Orientation: East-West			Study Period (hrs): 0.25					
Vehicle Volumes and Adjustments								
Major Street	Eastbound			Westbound				
Movement	1	2	3	4	5	6		
	L	T	R	L	T	R		
Volume (veh/h)		134	103	27	68			
Peak-Hour Factor, PHF	0.90	0.90	0.90	0.90	0.90	0.90		
Hourly Flow Rate, HFR (veh/h)	0	148	114	30	75	0		
Percent Heavy Vehicles	0	--	--	5	--	--		
Median Type	Undivided							
RT Channelized			0			0		
Lanes	0	1	1	0	1	0		
Configuration		T	R	LT				
Upstream Signal		0			0			
Minor Street	Northbound			Southbound				
Movement	7	8	9	10	11	12		
	L	T	R	L	T	R		
Volume (veh/h)				49	0	95		
Peak-Hour Factor, PHF	0.90	0.90	0.90	0.90	0.90	0.90		
Hourly Flow Rate, HFR (veh/h)	0	0	0	54	0	105		
Percent Heavy Vehicles	0	0	0	5	5	5		
Percent Grade (%)		0			0			
Flared Approach		N			N			
Storage		0			0			
RT Channelized			0			0		
Lanes	0	0	0	1	1	1		
Configuration				L	T	R		
Delay, Queue Length, and Level of Service								
Approach	Eastbound	Westbound	Northbound			Southbound		
Movement	1	4	7	8	9	10	11	12
Lane Configuration		LT				L	T	R
v (veh/h)		30				54	0	105
C (m) (veh/h)		1285				635	523	978
v/c		0.02				0.09	0.00	0.11
95% queue length		0.07				0.28	0.00	0.36
Control Delay (s/veh)		7.9				11.2	11.9	9.1
LOS		A				B	B	A
Approach Delay (s/veh)	--	--				9.8		
Approach LOS	--	--				A		

TWO-WAY STOP CONTROL SUMMARY								
General Information				Site Information				
Analyst	JEC			Intersection	12			
Agency/Co.	HNTB North Carolina, PC			Jurisdiction	Polk County			
Date Performed	3/15/2013			Analysis Year	2011 Base Year - 6 Lane			
Analysis Time Period	2011 PM Peak							
Project Description STIP I4400/I-4700 - I-26 Widening								
East/West Street: SR 1142 (Holbert Cove Rd)				North/South Street: I-26 SB Ramps				
Intersection Orientation: East-West				Study Period (hrs): 0.25				
Vehicle Volumes and Adjustments								
Major Street	Eastbound			Westbound				
Movement	1	2	3	4	5	6		
	L	T	R	L	T	R		
Volume (veh/h)		100	63	29	111			
Peak-Hour Factor, PHF	0.90	0.90	0.90	0.90	0.90	0.90		
Hourly Flow Rate, HFR (veh/h)	0	111	70	32	123	0		
Percent Heavy Vehicles	0	--	--	5	--	--		
Median Type	Undivided							
RT Channelized			0			0		
Lanes	0	1	1	0	1	0		
Configuration		T	R	LT				
Upstream Signal		0			0			
Minor Street	Northbound			Southbound				
Movement	7	8	9	10	11	12		
	L	T	R	L	T	R		
Volume (veh/h)				37	0	126		
Peak-Hour Factor, PHF	0.90	0.90	0.90	0.90	0.90	0.90		
Hourly Flow Rate, HFR (veh/h)	0	0	0	41	0	140		
Percent Heavy Vehicles	0	0	0	5	5	5		
Percent Grade (%)		0			0			
Flared Approach		N			N			
Storage		0			0			
RT Channelized			0			0		
Lanes	0	0	0	1	1	1		
Configuration				L	T	R		
Delay, Queue Length, and Level of Service								
Approach	Eastbound	Westbound	Northbound			Southbound		
Movement	1	4	7	8	9	10	11	12
Lane Configuration		LT				L	T	R
v (veh/h)		32				41	0	140
C (m) (veh/h)		1376				641	542	920
v/c		0.02				0.06	0.00	0.15
95% queue length		0.07				0.20	0.00	0.54
Control Delay (s/veh)		7.7				11.0	11.6	9.6
LOS		A				B	B	A
Approach Delay (s/veh)	--	--				9.9		
Approach LOS	--	--				A		

2011 Build 8 Lane

TWO-WAY STOP CONTROL SUMMARY								
General Information					Site Information			
Analyst	JEC				Intersection	11		
Agency/Co.	HNTB North Carolina, PC				Jurisdiction	Polk County		
Date Performed	3/15/2013				Analysis Year	2011 Base Year - 8 Lane		
Analysis Time Period	2011 AM Peak							
Project Description STIP I4400/I-4700 - I-26 Widening								
East/West Street: SR 1142 (Holbert Cove Rd)					North/South Street: I-26 SB Ramps			
Intersection Orientation: East-West					Study Period (hrs): 0.25			
Vehicle Volumes and Adjustments								
Major Street	Eastbound			Westbound				
Movement	1	2	3	4	5	6		
	L	T	R	L	T	R		
Volume (veh/h)	126	57			32	37		
Peak-Hour Factor, PHF	0.90	0.90	1.00	1.00	0.90	0.90		
Hourly Flow Rate, HFR (veh/h)	140	63	0	0	35	41		
Percent Heavy Vehicles	5	--	--	0	--	--		
Median Type	Undivided							
RT Channelized			0				0	
Lanes	0	1	0	0	1	1		
Configuration	LT				T	R		
Upstream Signal		0			0			
Minor Street	Northbound			Southbound				
Movement	7	8	9	10	11	12		
	L	T	R	L	T	R		
Volume (veh/h)	63	0	29					
Peak-Hour Factor, PHF	0.90	0.90	0.90	1.00	1.00	1.00		
Hourly Flow Rate, HFR (veh/h)	70	0	32	0	0	0		
Percent Heavy Vehicles	5	5	5	5	0	0		
Percent Grade (%)	0			0				
Flared Approach		N			N			
Storage		0			0			
RT Channelized			0				0	
Lanes	1	1	1	0	0	0		
Configuration	L	T	R					
Delay, Queue Length, and Level of Service								
Approach	Eastbound	Westbound	Northbound			Southbound		
Movement	1	4	7	8	9	10	11	12
Lane Configuration	LT		L	T	R			
v (veh/h)	140		70	0	32			
C (m) (veh/h)	1504		545	471	993			
v/c	0.09		0.13	0.00	0.03			
95% queue length	0.31		0.44	0.00	0.10			
Control Delay (s/veh)	7.6		12.6	12.6	8.7			
LOS	A		B	B	A			
Approach Delay (s/veh)	--	--	11.4					
Approach LOS	--	--	B					

TWO-WAY STOP CONTROL SUMMARY								
General Information				Site Information				
Analyst	JEC			Intersection	11			
Agency/Co.	HNTB North Carolina, PC			Jurisdiction	Polk County			
Date Performed	3/15/2013			Analysis Year	2011 Base Year - 8 Lane			
Analysis Time Period	2011 PM Peak							
Project Description STIP I4400/I-4700 - I-26 Widening								
East/West Street: SR 1142 (Holbert Cove Rd)				North/South Street: I-26 NB Ramps				
Intersection Orientation: East-West				Study Period (hrs): 0.25				
Vehicle Volumes and Adjustments								
Major Street	Eastbound			Westbound				
Movement	1	2	3	4	5	6		
	L	T	R	L	T	R		
Volume (veh/h)	95	42			37	49		
Peak-Hour Factor, PHF	0.90	0.90	1.00	1.00	0.90	0.90		
Hourly Flow Rate, HFR (veh/h)	105	46	0	0	41	54		
Percent Heavy Vehicles	5	--	--	0	--	--		
Median Type	Undivided							
RT Channelized			0			0		
Lanes	0	1	0	0	1	1		
Configuration	LT				T	R		
Upstream Signal		0			0			
Minor Street	Northbound			Southbound				
Movement	7	8	9	10	11	12		
	L	T	R	L	T	R		
Volume (veh/h)	103	0	27					
Peak-Hour Factor, PHF	0.90	0.90	0.90	1.00	1.00	1.00		
Hourly Flow Rate, HFR (veh/h)	114	0	30	0	0	0		
Percent Heavy Vehicles	5	5	5	5	0	0		
Percent Grade (%)		0			0			
Flared Approach		N			N			
Storage		0			0			
RT Channelized			0			0		
Lanes	1	1	1	0	0	0		
Configuration	L	T	R					
Delay, Queue Length, and Level of Service								
Approach	Eastbound	Westbound	Northbound			Southbound		
Movement	1	4	7	8	9	10	11	12
Lane Configuration	LT		L	T	R			
v (veh/h)	105		114	0	30			
C (m) (veh/h)	1480		617	528	1015			
v/c	0.07		0.18	0.00	0.03			
95% queue length	0.23		0.67	0.00	0.09			
Control Delay (s/veh)	7.6		12.2	11.8	8.7			
LOS	A		B	B	A			
Approach Delay (s/veh)	--	--	11.4					
Approach LOS	--	--	B					

TWO-WAY STOP CONTROL SUMMARY

General Information			Site Information					
Analyst	JEC		Intersection	12				
Agency/Co.	HNTB North Carolina, PC		Jurisdiction	Polk County				
Date Performed	3/15/2013		Analysis Year	2011 Base Year - 8 Lane				
Analysis Time Period	2011 AM Peak							
Project Description STIP I4400/I-4700 - I-26 Widening								
East/West Street: SR 1142 (Holbert Cove Rd)			North/South Street: I-26 SB Ramps					
Intersection Orientation: East-West			Study Period (hrs): 0.25					
Vehicle Volumes and Adjustments								
Major Street	Eastbound			Westbound				
Movement	1	2	3	4	5	6		
	L	T	R	L	T	R		
Volume (veh/h)		134	103	27	68			
Peak-Hour Factor, PHF	0.90	0.90	0.90	0.90	0.90	0.90		
Hourly Flow Rate, HFR (veh/h)	0	148	114	30	75	0		
Percent Heavy Vehicles	0	--	--	5	--	--		
Median Type	Undivided							
RT Channelized			0			0		
Lanes	0	1	1	0	1	0		
Configuration		T	R	LT				
Upstream Signal		0			0			
Minor Street	Northbound			Southbound				
Movement	7	8	9	10	11	12		
	L	T	R	L	T	R		
Volume (veh/h)				49	0	95		
Peak-Hour Factor, PHF	0.90	0.90	0.90	0.90	0.90	0.90		
Hourly Flow Rate, HFR (veh/h)	0	0	0	54	0	105		
Percent Heavy Vehicles	0	0	0	5	5	5		
Percent Grade (%)		0			0			
Flared Approach		N			N			
Storage		0			0			
RT Channelized			0			0		
Lanes	0	0	0	1	1	1		
Configuration				L	T	R		
Delay, Queue Length, and Level of Service								
Approach	Eastbound	Westbound	Northbound			Southbound		
Movement	1	4	7	8	9	10	11	12
Lane Configuration		LT				L	T	R
v (veh/h)		30				54	0	105
C (m) (veh/h)		1285				635	523	978
v/c		0.02				0.09	0.00	0.11
95% queue length		0.07				0.28	0.00	0.36
Control Delay (s/veh)		7.9				11.2	11.9	9.1
LOS		A				B	B	A
Approach Delay (s/veh)	--	--				9.8		
Approach LOS	--	--				A		

TWO-WAY STOP CONTROL SUMMARY								
General Information				Site Information				
Analyst	JEC			Intersection	12			
Agency/Co.	HNTB North Carolina, PC			Jurisdiction	Polk County			
Date Performed	3/15/2013			Analysis Year	2011 Base Year - 8 Lane			
Analysis Time Period	2011 PM Peak							
Project Description STIP I4400/I-4700 - I-26 Widening								
East/West Street: SR 1142 (Holbert Cove Rd)				North/South Street: I-26 SB Ramps				
Intersection Orientation: East-West				Study Period (hrs): 0.25				
Vehicle Volumes and Adjustments								
Major Street	Eastbound			Westbound				
Movement	1	2	3	4	5	6		
	L	T	R	L	T	R		
Volume (veh/h)		100	63	29	111			
Peak-Hour Factor, PHF	0.90	0.90	0.90	0.90	0.90	0.90		
Hourly Flow Rate, HFR (veh/h)	0	111	70	32	123	0		
Percent Heavy Vehicles	0	--	--	5	--	--		
Median Type	Undivided							
RT Channelized			0			0		
Lanes	0	1	1	0	1	0		
Configuration		T	R	LT				
Upstream Signal		0			0			
Minor Street	Northbound			Southbound				
Movement	7	8	9	10	11	12		
	L	T	R	L	T	R		
Volume (veh/h)				37	0	126		
Peak-Hour Factor, PHF	0.90	0.90	0.90	0.90	0.90	0.90		
Hourly Flow Rate, HFR (veh/h)	0	0	0	41	0	140		
Percent Heavy Vehicles	0	0	0	5	5	5		
Percent Grade (%)		0			0			
Flared Approach		N			N			
Storage		0			0			
RT Channelized			0			0		
Lanes	0	0	0	1	1	1		
Configuration				L	T	R		
Delay, Queue Length, and Level of Service								
Approach	Eastbound	Westbound	Northbound			Southbound		
Movement	1	4	7	8	9	10	11	12
Lane Configuration		LT				L	T	R
v (veh/h)		32				41	0	140
C (m) (veh/h)		1376				641	542	920
v/c		0.02				0.06	0.00	0.15
95% queue length		0.07				0.20	0.00	0.54
Control Delay (s/veh)		7.7				11.0	11.6	9.6
LOS		A				B	B	A
Approach Delay (s/veh)	--	--				9.9		
Approach LOS	--	--				A		

2040 No-Build

TWO-WAY STOP CONTROL SUMMARY								
General Information				Site Information				
Analyst	JEC			Intersection	11			
Agency/Co.	HNTB North Carolina, PC			Jurisdiction	Polk County			
Date Performed	3/15/2013			Analysis Year	2040 Design Year - No Build			
Analysis Time Period	2040 AM Peak							
Project Description STIP I4400/I-4700 - I-26 Widening								
East/West Street: SR 1142 (Holbert Cove Rd)				North/South Street: I-26 SB Ramps				
Intersection Orientation: East-West				Study Period (hrs): 0.25				
Vehicle Volumes and Adjustments								
Major Street	Eastbound			Westbound				
Movement	1	2	3	4	5	6		
	L	T	R	L	T	R		
Volume (veh/h)	139	60			62	56		
Peak-Hour Factor, PHF	0.90	0.90	1.00	1.00	0.90	0.90		
Hourly Flow Rate, HFR (veh/h)	154	66	0	0	68	62		
Percent Heavy Vehicles	5	--	--	0	--	--		
Median Type	Undivided							
RT Channelized			0				0	
Lanes	0	1	0	0	1	1		
Configuration	LT				T	R		
Upstream Signal		0			0			
Minor Street	Northbound			Southbound				
Movement	7	8	9	10	11	12		
	L	T	R	L	T	R		
Volume (veh/h)	88	0	63					
Peak-Hour Factor, PHF	0.90	0.90	0.90	1.00	1.00	1.00		
Hourly Flow Rate, HFR (veh/h)	97	0	70	0	0	0		
Percent Heavy Vehicles	5	5	5	5	0	0		
Percent Grade (%)	0			0				
Flared Approach		N			N			
Storage		0			0			
RT Channelized			0				0	
Lanes	1	1	1	0	0	0		
Configuration	L	T	R					
Delay, Queue Length, and Level of Service								
Approach	Eastbound	Westbound	Northbound			Southbound		
Movement	1	4	7	8	9	10	11	12
Lane Configuration	LT		L	T	R			
v (veh/h)	154		97	0	70			
C (m) (veh/h)	1437		486	414	989			
v/c	0.11		0.20	0.00	0.07			
95% queue length	0.36		0.74	0.00	0.23			
Control Delay (s/veh)	7.8		14.2	13.7	8.9			
LOS	A		B	B	A			
Approach Delay (s/veh)	--	--	12.0					
Approach LOS	--	--	B					

TWO-WAY STOP CONTROL SUMMARY								
General Information				Site Information				
Analyst	JEC			Intersection	11			
Agency/Co.	HNTB North Carolina, PC			Jurisdiction	Polk County			
Date Performed	3/15/2013			Analysis Year	2040 Design Year - No Build			
Analysis Time Period	2040 PM Peak							
Project Description STIP I4400/I-4700 - I-26 Widening								
East/West Street: SR 1142 (Holbert Cove Rd)				North/South Street: I-26 SB Ramps				
Intersection Orientation: East-West				Study Period (hrs): 0.25				
Vehicle Volumes and Adjustments								
Major Street	Eastbound			Westbound				
Movement	1	2	3	4	5	6		
	L	T	R	L	T	R		
Volume (veh/h)	104	83			71	75		
Peak-Hour Factor, PHF	0.90	0.90	1.00	1.00	0.90	0.90		
Hourly Flow Rate, HFR (veh/h)	115	92	0	0	78	83		
Percent Heavy Vehicles	5	--	--	0	--	--		
Median Type	Undivided							
RT Channelized			0			0		
Lanes	0	1	0	0	1	1		
Configuration	LT				T	R		
Upstream Signal		0			0			
Minor Street	Northbound			Southbound				
Movement	7	8	9	10	11	12		
	L	T	R	L	T	R		
Volume (veh/h)	145	0	58					
Peak-Hour Factor, PHF	0.90	0.90	0.90	1.00	1.00	1.00		
Hourly Flow Rate, HFR (veh/h)	161	0	64	0	0	0		
Percent Heavy Vehicles	5	5	5	5	0	0		
Percent Grade (%)	0			0				
Flared Approach		N			N			
Storage		0			0			
RT Channelized			0			0		
Lanes	1	1	1	0	0	0		
Configuration	L	T	R					
Delay, Queue Length, and Level of Service								
Approach	Eastbound	Westbound	Northbound			Southbound		
Movement	1	4	7	8	9	10	11	12
Lane Configuration	LT		L	T	R			
v (veh/h)	115		161	0	64			
C (m) (veh/h)	1400		520	437	957			
v/c	0.08		0.31	0.00	0.07			
95% queue length	0.27		1.31	0.00	0.21			
Control Delay (s/veh)	7.8		15.0	13.2	9.0			
LOS	A		B	B	A			
Approach Delay (s/veh)	--	--	13.3					
Approach LOS	--	--	B					

TWO-WAY STOP CONTROL SUMMARY								
General Information				Site Information				
Analyst	JEC			Intersection	12			
Agency/Co.	HNTB North Carolina, PC			Jurisdiction	Polk County			
Date Performed	3/15/2013			Analysis Year	2040 Design Year - No Build			
Analysis Time Period	2040 AM Peak							
Project Description STIP I4400/I-4700 - I-26 Widening								
East/West Street: SR 1142 (Holbert Cove Rd)				North/South Street: I-26 SB Ramps				
Intersection Orientation: East-West				Study Period (hrs): 0.25				
Vehicle Volumes and Adjustments								
Major Street	Eastbound			Westbound				
Movement	1	2	3	4	5	6		
	L	T	R	L	T	R		
Volume (veh/h)		147	145	58	92			
Peak-Hour Factor, PHF	0.90	0.90	0.90	0.90	0.90	0.90		
Hourly Flow Rate, HFR (veh/h)	0	163	161	64	102	0		
Percent Heavy Vehicles	0	--	--	5	--	--		
Median Type	Undivided							
RT Channelized			0			0		
Lanes	0	1	1	0	1	0		
Configuration		T	R	LT				
Upstream Signal		0			0			
Minor Street	Northbound			Southbound				
Movement	7	8	9	10	11	12		
	L	T	R	L	T	R		
Volume (veh/h)				75	0	105		
Peak-Hour Factor, PHF	0.90	0.90	0.90	0.90	0.90	0.90		
Hourly Flow Rate, HFR (veh/h)	0	0	0	83	0	116		
Percent Heavy Vehicles	0	0	0	5	5	5		
Percent Grade (%)	0			0				
Flared Approach		N			N			
Storage		0			0			
RT Channelized			0			0		
Lanes	0	0	0	1	1	1		
Configuration				L	T	R		
Delay, Queue Length, and Level of Service								
Approach	Eastbound	Westbound	Northbound			Southbound		
Movement	1	4	7	8	9	10	11	12
Lane Configuration		LT				L	T	R
v (veh/h)		64				83	0	116
C (m) (veh/h)		1219				515	412	945
v/c		0.05				0.16	0.00	0.12
95% queue length		0.17				0.57	0.00	0.42
Control Delay (s/veh)		8.1				13.3	13.7	9.3
LOS		A				B	B	A
Approach Delay (s/veh)	--	--				11.0		
Approach LOS	--	--				B		

TWO-WAY STOP CONTROL SUMMARY								
General Information				Site Information				
Analyst	JEC			Intersection	12			
Agency/Co.	HNTB North Carolina, PC			Jurisdiction	Polk County			
Date Performed	3/15/2013			Analysis Year	2040 Design Year - No Build			
Analysis Time Period	2040 PM Peak							
Project Description STIP I4400/I-4700 - I-26 Widening								
East/West Street: SR 1142 (Holbert Cove Rd)				North/South Street: I-26 SB Ramps				
Intersection Orientation: East-West				Study Period (hrs): 0.25				
Vehicle Volumes and Adjustments								
Major Street	Eastbound			Westbound				
Movement	1	2	3	4	5	6		
	L	T	R	L	T	R		
Volume (veh/h)		108	88	63	153			
Peak-Hour Factor, PHF	0.90	0.90	0.90	0.90	0.90	0.90		
Hourly Flow Rate, HFR (veh/h)	0	120	97	70	170	0		
Percent Heavy Vehicles	0	--	--	5	--	--		
Median Type	Undivided							
RT Channelized			0			0		
Lanes	0	1	1	0	1	0		
Configuration		T	R	LT				
Upstream Signal		0			0			
Minor Street	Northbound			Southbound				
Movement	7	8	9	10	11	12		
	L	T	R	L	T	R		
Volume (veh/h)				56	0	139		
Peak-Hour Factor, PHF	0.90	0.90	0.90	0.90	0.90	0.90		
Hourly Flow Rate, HFR (veh/h)	0	0	0	62	0	154		
Percent Heavy Vehicles	0	0	0	5	5	5		
Percent Grade (%)	0			0				
Flared Approach		N			N			
Storage		0			0			
RT Channelized			0			0		
Lanes	0	0	0	1	1	1		
Configuration				L	T	R		
Delay, Queue Length, and Level of Service								
Approach	Eastbound	Westbound	Northbound			Southbound		
Movement	1	4	7	8	9	10	11	12
Lane Configuration		LT				L	T	R
v (veh/h)		70				62	0	154
C (m) (veh/h)		1335				513	426	866
v/c		0.05				0.12	0.00	0.18
95% queue length		0.17				0.41	0.00	0.64
Control Delay (s/veh)		7.8				13.0	13.5	10.1
LOS		A				B	B	B
Approach Delay (s/veh)	--	--				10.9		
Approach LOS	--	--				B		

2040 Build 6 Lane

TWO-WAY STOP CONTROL SUMMARY								
General Information				Site Information				
Analyst	JEC			Intersection	11			
Agency/Co.	HNTB North Carolina, PC			Jurisdiction	Polk County			
Date Performed	3/15/2013			Analysis Year	2040 Design Year - 6 Lane			
Analysis Time Period	2040 AM Peak							
Project Description STIP I4400/I-4700 - I-26 Widening								
East/West Street: SR 1142 (Holbert Cove Rd)				North/South Street: I-26 SB Ramps				
Intersection Orientation: East-West				Study Period (hrs): 0.25				
Vehicle Volumes and Adjustments								
Major Street	Eastbound			Westbound				
Movement	1	2	3	4	5	6		
	L	T	R	L	T	R		
Volume (veh/h)	139	83			62	56		
Peak-Hour Factor, PHF	0.90	0.90	1.00	1.00	0.90	0.90		
Hourly Flow Rate, HFR (veh/h)	154	92	0	0	68	62		
Percent Heavy Vehicles	5	--	--	0	--	--		
Median Type	Undivided							
RT Channelized			0				0	
Lanes	0	1	0	0	1	1		
Configuration	LT				T	R		
Upstream Signal		0			0			
Minor Street	Northbound			Southbound				
Movement	7	8	9	10	11	12		
	L	T	R	L	T	R		
Volume (veh/h)	88	0	63					
Peak-Hour Factor, PHF	0.90	0.90	0.90	1.00	1.00	1.00		
Hourly Flow Rate, HFR (veh/h)	97	0	70	0	0	0		
Percent Heavy Vehicles	5	5	5	5	0	0		
Percent Grade (%)	0			0				
Flared Approach		N			N			
Storage		0			0			
RT Channelized			0				0	
Lanes	1	1	1	0	0	0		
Configuration	L	T	R					
Delay, Queue Length, and Level of Service								
Approach	Eastbound	Westbound	Northbound			Southbound		
Movement	1	4	7	8	9	10	11	12
Lane Configuration	LT		L	T	R			
v (veh/h)	154		97	0	70			
C (m) (veh/h)	1437		470	399	957			
v/c	0.11		0.21	0.00	0.07			
95% queue length	0.36		0.77	0.00	0.24			
Control Delay (s/veh)	7.8		14.6	14.0	9.1			
LOS	A		B	B	A			
Approach Delay (s/veh)	--	--	12.3					
Approach LOS	--	--	B					

TWO-WAY STOP CONTROL SUMMARY								
General Information				Site Information				
Analyst	JEC			Intersection	11			
Agency/Co.	HNTB North Carolina, PC			Jurisdiction	Polk County			
Date Performed	3/15/2013			Analysis Year	2040 Design Year - 6 Lane			
Analysis Time Period	2040 PM Peak							
Project Description STIP I4400/I-4700 - I-26 Widening								
East/West Street: SR 1142 (Holbert Cove Rd)				North/South Street: I-26 SB Ramps				
Intersection Orientation: East-West				Study Period (hrs): 0.25				
Vehicle Volumes and Adjustments								
Major Street	Eastbound			Westbound				
Movement	1	2	3	4	5	6		
	L	T	R	L	T	R		
Volume (veh/h)	104	60			71	75		
Peak-Hour Factor, PHF	0.90	0.90	1.00	1.00	0.90	0.90		
Hourly Flow Rate, HFR (veh/h)	115	66	0	0	78	83		
Percent Heavy Vehicles	5	--	--	0	--	--		
Median Type	Undivided							
RT Channelized			0				0	
Lanes	0	1	0	0	1	1		
Configuration	LT				T	R		
Upstream Signal		0			0			
Minor Street	Northbound			Southbound				
Movement	7	8	9	10	11	12		
	L	T	R	L	T	R		
Volume (veh/h)	145	0	58					
Peak-Hour Factor, PHF	0.90	0.90	0.90	1.00	1.00	1.00		
Hourly Flow Rate, HFR (veh/h)	161	0	64	0	0	0		
Percent Heavy Vehicles	5	5	5	5	0	0		
Percent Grade (%)	0			0				
Flared Approach		N			N			
Storage		0			0			
RT Channelized			0				0	
Lanes	1	1	1	0	0	0		
Configuration	L	T	R					
Delay, Queue Length, and Level of Service								
Approach	Eastbound	Westbound	Northbound			Southbound		
Movement	1	4	7	8	9	10	11	12
Lane Configuration	LT		L	T	R			
v (veh/h)	115		161	0	64			
C (m) (veh/h)	1400		539	453	989			
v/c	0.08		0.30	0.00	0.06			
95% queue length	0.27		1.24	0.00	0.21			
Control Delay (s/veh)	7.8		14.5	12.9	8.9			
LOS	A		B	B	A			
Approach Delay (s/veh)	--	--	12.9					
Approach LOS	--	--	B					

TWO-WAY STOP CONTROL SUMMARY								
General Information				Site Information				
Analyst	JEC			Intersection	12			
Agency/Co.	HNTB North Carolina, PC			Jurisdiction	Polk County			
Date Performed	3/15/2013			Analysis Year	2040 Design Year - 6 Lane			
Analysis Time Period	2040 AM Peak							
Project Description STIP I4400/I-4700 - I-26 Widening								
East/West Street: SR 1142 (Holbert Cove Rd)				North/South Street: I-26 SB Ramps				
Intersection Orientation: East-West				Study Period (hrs): 0.25				
Vehicle Volumes and Adjustments								
Major Street	Eastbound			Westbound				
Movement	1	2	3	4	5	6		
	L	T	R	L	T	R		
Volume (veh/h)		147	145	58	92			
Peak-Hour Factor, PHF	0.90	0.90	0.90	0.90	0.90	0.90		
Hourly Flow Rate, HFR (veh/h)	0	163	161	64	102	0		
Percent Heavy Vehicles	0	--	--	5	--	--		
Median Type	Undivided							
RT Channelized			0			0		
Lanes	0	1	1	0	1	0		
Configuration		T	R	LT				
Upstream Signal		0			0			
Minor Street	Northbound			Southbound				
Movement	7	8	9	10	11	12		
	L	T	R	L	T	R		
Volume (veh/h)				75	0	105		
Peak-Hour Factor, PHF	0.90	0.90	0.90	0.90	0.90	0.90		
Hourly Flow Rate, HFR (veh/h)	0	0	0	83	0	116		
Percent Heavy Vehicles	0	0	0	5	5	5		
Percent Grade (%)	0			0				
Flared Approach		N			N			
Storage		0			0			
RT Channelized			0			0		
Lanes	0	0	0	1	1	1		
Configuration				L	T	R		
Delay, Queue Length, and Level of Service								
Approach	Eastbound	Westbound	Northbound			Southbound		
Movement	1	4	7	8	9	10	11	12
Lane Configuration		LT				L	T	R
v (veh/h)		64				83	0	116
C (m) (veh/h)		1219				515	412	945
v/c		0.05				0.16	0.00	0.12
95% queue length		0.17				0.57	0.00	0.42
Control Delay (s/veh)		8.1				13.3	13.7	9.3
LOS		A				B	B	A
Approach Delay (s/veh)	--	--				11.0		
Approach LOS	--	--				B		

TWO-WAY STOP CONTROL SUMMARY								
General Information				Site Information				
Analyst	JEC			Intersection	12			
Agency/Co.	HNTB North Carolina, PC			Jurisdiction	Polk County			
Date Performed	3/15/2013			Analysis Year	2040 Design Year - 6 Lane			
Analysis Time Period	2040 PM Peak							
Project Description STIP I4400/I-4700 - I-26 Widening								
East/West Street: SR 1142 (Holbert Cove Rd)				North/South Street: I-26 SB Ramps				
Intersection Orientation: East-West				Study Period (hrs): 0.25				
Vehicle Volumes and Adjustments								
Major Street	Eastbound			Westbound				
Movement	1	2	3	4	5	6		
	L	T	R	L	T	R		
Volume (veh/h)		108	88	63	153			
Peak-Hour Factor, PHF	0.90	0.90	0.90	0.90	0.90	0.90		
Hourly Flow Rate, HFR (veh/h)	0	120	97	70	170	0		
Percent Heavy Vehicles	0	--	--	5	--	--		
Median Type	Undivided							
RT Channelized			0			0		
Lanes	0	1	1	0	1	0		
Configuration		T	R	LT				
Upstream Signal		0			0			
Minor Street	Northbound			Southbound				
Movement	7	8	9	10	11	12		
	L	T	R	L	T	R		
Volume (veh/h)				56	0	139		
Peak-Hour Factor, PHF	0.90	0.90	0.90	0.90	0.90	0.90		
Hourly Flow Rate, HFR (veh/h)	0	0	0	62	0	154		
Percent Heavy Vehicles	0	0	0	5	5	5		
Percent Grade (%)	0			0				
Flared Approach		N			N			
Storage		0			0			
RT Channelized			0			0		
Lanes	0	0	0	1	1	1		
Configuration				L	T	R		
Delay, Queue Length, and Level of Service								
Approach	Eastbound	Westbound	Northbound			Southbound		
Movement	1	4	7	8	9	10	11	12
Lane Configuration		LT				L	T	R
v (veh/h)		70				62	0	154
C (m) (veh/h)		1335				513	426	866
v/c		0.05				0.12	0.00	0.18
95% queue length		0.17				0.41	0.00	0.64
Control Delay (s/veh)		7.8				13.0	13.5	10.1
LOS		A				B	B	B
Approach Delay (s/veh)	--	--				10.9		
Approach LOS	--	--				B		

2040 Build 8 Lane

TWO-WAY STOP CONTROL SUMMARY								
General Information				Site Information				
Analyst	JEC			Intersection	11			
Agency/Co.	HNTB North Carolina, PC			Jurisdiction	Polk County			
Date Performed	3/15/2013			Analysis Year	2040 Design Year - 8 Lane			
Analysis Time Period	2040 AM Peak							
Project Description STIP I4400/I-4700 - I-26 Widening								
East/West Street: SR 1142 (Holbert Cove Rd)				North/South Street: I-26 SB Ramps				
Intersection Orientation: East-West				Study Period (hrs): 0.25				
Vehicle Volumes and Adjustments								
Major Street	Eastbound			Westbound				
Movement	1	2	3	4	5	6		
	L	T	R	L	T	R		
Volume (veh/h)	139	83			62	56		
Peak-Hour Factor, PHF	0.90	0.90	1.00	1.00	0.90	0.90		
Hourly Flow Rate, HFR (veh/h)	154	92	0	0	68	62		
Percent Heavy Vehicles	5	--	--	0	--	--		
Median Type	Undivided							
RT Channelized			0				0	
Lanes	0	1	0	0	1	1		
Configuration	LT				T	R		
Upstream Signal		0			0			
Minor Street	Northbound			Southbound				
Movement	7	8	9	10	11	12		
	L	T	R	L	T	R		
Volume (veh/h)	88	0	63					
Peak-Hour Factor, PHF	0.90	0.90	0.90	1.00	1.00	1.00		
Hourly Flow Rate, HFR (veh/h)	97	0	70	0	0	0		
Percent Heavy Vehicles	5	5	5	5	0	0		
Percent Grade (%)	0			0				
Flared Approach		N			N			
Storage		0			0			
RT Channelized			0				0	
Lanes	1	1	1	0	0	0		
Configuration	L	T	R					
Delay, Queue Length, and Level of Service								
Approach	Eastbound	Westbound	Northbound			Southbound		
Movement	1	4	7	8	9	10	11	12
Lane Configuration	LT		L	T	R			
v (veh/h)	154		97	0	70			
C (m) (veh/h)	1437		470	399	957			
v/c	0.11		0.21	0.00	0.07			
95% queue length	0.36		0.77	0.00	0.24			
Control Delay (s/veh)	7.8		14.6	14.0	9.1			
LOS	A		B	B	A			
Approach Delay (s/veh)	--	--	12.3					
Approach LOS	--	--	B					

TWO-WAY STOP CONTROL SUMMARY								
General Information				Site Information				
Analyst	JEC			Intersection	11			
Agency/Co.	HNTB North Carolina, PC			Jurisdiction	Polk County			
Date Performed	3/15/2013			Analysis Year	2040 Design Year - 8 Lane			
Analysis Time Period	2040 PM Peak							
Project Description STIP I4400/I-4700 - I-26 Widening								
East/West Street: SR 1142 (Holbert Cove Rd)				North/South Street: I-26 SB Ramps				
Intersection Orientation: East-West				Study Period (hrs): 0.25				
Vehicle Volumes and Adjustments								
Major Street	Eastbound			Westbound				
Movement	1	2	3	4	5	6		
	L	T	R	L	T	R		
Volume (veh/h)	104	60			71	75		
Peak-Hour Factor, PHF	0.90	0.90	1.00	1.00	0.90	0.90		
Hourly Flow Rate, HFR (veh/h)	115	66	0	0	78	83		
Percent Heavy Vehicles	5	--	--	0	--	--		
Median Type	Undivided							
RT Channelized			0				0	
Lanes	0	1	0	0	1	1		
Configuration	LT				T	R		
Upstream Signal		0			0			
Minor Street	Northbound			Southbound				
Movement	7	8	9	10	11	12		
	L	T	R	L	T	R		
Volume (veh/h)	145	0	58					
Peak-Hour Factor, PHF	0.90	0.90	0.90	1.00	1.00	1.00		
Hourly Flow Rate, HFR (veh/h)	161	0	64	0	0	0		
Percent Heavy Vehicles	5	5	5	5	0	0		
Percent Grade (%)	0			0				
Flared Approach		N			N			
Storage		0			0			
RT Channelized			0				0	
Lanes	1	1	1	0	0	0		
Configuration	L	T	R					
Delay, Queue Length, and Level of Service								
Approach	Eastbound	Westbound	Northbound			Southbound		
Movement	1	4	7	8	9	10	11	12
Lane Configuration	LT		L	T	R			
v (veh/h)	115		161	0	64			
C (m) (veh/h)	1400		539	453	989			
v/c	0.08		0.30	0.00	0.06			
95% queue length	0.27		1.24	0.00	0.21			
Control Delay (s/veh)	7.8		14.5	12.9	8.9			
LOS	A		B	B	A			
Approach Delay (s/veh)	--	--	12.9					
Approach LOS	--	--	B					

TWO-WAY STOP CONTROL SUMMARY								
General Information				Site Information				
Analyst	JEC			Intersection	12			
Agency/Co.	HNTB North Carolina, PC			Jurisdiction	Polk County			
Date Performed	3/15/2013			Analysis Year	2040 Design Year - 8 Lane			
Analysis Time Period	2040 AM Peak							
Project Description STIP I4400/I-4700 - I-26 Widening								
East/West Street: SR 1142 (Holbert Cove Rd)				North/South Street: I-26 SB Ramps				
Intersection Orientation: East-West				Study Period (hrs): 0.25				
Vehicle Volumes and Adjustments								
Major Street	Eastbound			Westbound				
Movement	1	2	3	4	5	6		
	L	T	R	L	T	R		
Volume (veh/h)		147	145	58	92			
Peak-Hour Factor, PHF	0.90	0.90	0.90	0.90	0.90	0.90		
Hourly Flow Rate, HFR (veh/h)	0	163	161	64	102	0		
Percent Heavy Vehicles	0	--	--	5	--	--		
Median Type	Undivided							
RT Channelized			0			0		
Lanes	0	1	1	0	1	0		
Configuration		T	R	LT				
Upstream Signal		0			0			
Minor Street	Northbound			Southbound				
Movement	7	8	9	10	11	12		
	L	T	R	L	T	R		
Volume (veh/h)				75	0	105		
Peak-Hour Factor, PHF	0.90	0.90	0.90	0.90	0.90	0.90		
Hourly Flow Rate, HFR (veh/h)	0	0	0	83	0	116		
Percent Heavy Vehicles	0	0	0	5	5	5		
Percent Grade (%)	0			0				
Flared Approach		N			N			
Storage		0			0			
RT Channelized			0			0		
Lanes	0	0	0	1	1	1		
Configuration				L	T	R		
Delay, Queue Length, and Level of Service								
Approach	Eastbound	Westbound	Northbound			Southbound		
Movement	1	4	7	8	9	10	11	12
Lane Configuration		LT				L	T	R
v (veh/h)		64				83	0	116
C (m) (veh/h)		1219				515	412	945
v/c		0.05				0.16	0.00	0.12
95% queue length		0.17				0.57	0.00	0.42
Control Delay (s/veh)		8.1				13.3	13.7	9.3
LOS		A				B	B	A
Approach Delay (s/veh)	--	--				11.0		
Approach LOS	--	--				B		

TWO-WAY STOP CONTROL SUMMARY								
General Information				Site Information				
Analyst	JEC			Intersection	12			
Agency/Co.	HNTB North Carolina, PC			Jurisdiction	Polk County			
Date Performed	3/15/2013			Analysis Year	2040 Design Year - 8 Lane			
Analysis Time Period	2040 PM Peak							
Project Description STIP I4400/I-4700 - I-26 Widening								
East/West Street: SR 1142 (Holbert Cove Rd)				North/South Street: I-26 SB Ramps				
Intersection Orientation: East-West				Study Period (hrs): 0.25				
Vehicle Volumes and Adjustments								
Major Street	Eastbound			Westbound				
Movement	1	2	3	4	5	6		
	L	T	R	L	T	R		
Volume (veh/h)		108	88	63	153			
Peak-Hour Factor, PHF	0.90	0.90	0.90	0.90	0.90	0.90		
Hourly Flow Rate, HFR (veh/h)	0	120	97	70	170	0		
Percent Heavy Vehicles	0	--	--	5	--	--		
Median Type	Undivided							
RT Channelized			0			0		
Lanes	0	1	1	0	1	0		
Configuration		T	R	LT				
Upstream Signal		0			0			
Minor Street	Northbound			Southbound				
Movement	7	8	9	10	11	12		
	L	T	R	L	T	R		
Volume (veh/h)				56	0	139		
Peak-Hour Factor, PHF	0.90	0.90	0.90	0.90	0.90	0.90		
Hourly Flow Rate, HFR (veh/h)	0	0	0	62	0	154		
Percent Heavy Vehicles	0	0	0	5	5	5		
Percent Grade (%)	0			0				
Flared Approach		N			N			
Storage		0			0			
RT Channelized			0			0		
Lanes	0	0	0	1	1	1		
Configuration				L	T	R		
Delay, Queue Length, and Level of Service								
Approach	Eastbound	Westbound	Northbound			Southbound		
Movement	1	4	7	8	9	10	11	12
Lane Configuration		LT				L	T	R
v (veh/h)		70				62	0	154
C (m) (veh/h)		1335				513	426	866
v/c		0.05				0.12	0.00	0.18
95% queue length		0.17				0.41	0.00	0.64
Control Delay (s/veh)		7.8				13.0	13.5	10.1
LOS		A				B	B	B
Approach Delay (s/veh)	--	--				10.9		
Approach LOS	--	--				B		

Appendix F – STIP I-5501 Analysis



STATE OF NORTH CAROLINA
DEPARTMENT OF TRANSPORTATION

BEVERLY EAVES PERDUE
GOVERNOR

April 13, 2012

EUGENE A. CONTI, JR.
SECRETARY

TIP Project: I-5501
Division: 13
County: Buncombe
Description: I-26 and NC 280 (Airport Road) Interchange Analysis in Asheville

MEMORANDUM

To: Gregory J. Thorpe, Ph.D., Manager
Project Development and Environmental Analysis Unit
Attention: Undrea J. Major, Project Development Engineer

From: James H. Dunlop, P. E., Congestion Management Engineer
Congestion Management Section

Subject: I-26 and NC 280 (Airport Road) Interchange Modifications



The Congestion Management Section has completed a review of the subject interchange for improvements related to TIP project I-5501. This analysis reviewed traditional diamond interchange and diverging diamond interchange (DDI) configurations to determine viable alternatives for the interchange.

The analysis was based on the traffic forecast developed by the Transportation Planning Branch dated February 14, 2012 for the TIP I-4400/I-4700/B-5178/I-5501. All analyses were performed for the existing year (2011) and design year (2040) AM/PM peak hour volumes using Synchro/SimTraffic, Version 7. Both the 2011 and 2040 forecasts included three scenarios for I-26: no-build, six lanes, and eight lanes. NC 280 is an undivided multilane strategic highway corridor (SHC) expressway and we assumed the base geometric layout of this road will not change by the design year.

Base year (2011) and design year (2040) No-Build/Build Analysis - I-26 and NC 280 Interchange:

Congestion Management analyzed a traditional diamond interchange and a diverging diamond interchange for both existing (2011) No-build/Build and design year (2040) No-build/Build conditions.

Based on our analysis, a diverging diamond interchange would not require widening the existing NC 280 Bridge. Both EB and WB off-ramps would require dual left-turn lanes and dual right-turn lanes under signal control to accommodate design year traffic volumes. The EB on-ramp and WB on-ramps may need two-lane ramps with free-flow traffic movements requiring a lane drop before the gore area on I-26.

A traditional diamond interchange would require widening the existing bridge from six lanes to seven lanes. Both EB and WB off-ramps would require dual left-turn lanes and dual right-turn lanes

under signal control. The EB off-ramp requires a two-lane ramp and the outermost lane would need to drop before the area of EB I-26. The WB on-ramp required three lanes thus requiring two-lane drops. Spacing limitations would likely require two lanes to be carried onto the main roadway of I-26, requiring additional widening.

Comparing a traditional diamond interchange and a DDI, a DDI configuration appears superior and operates better. Geometric improvements would be needed under either scenario. Intersections along NC 280 beyond the interchange will need to be upgraded in the future to allow effective traffic operations along the NC 280 corridor.

We recommend installing a DDI with the existing bridge and lane geometry as shown in the attached diagram. A traffic analysis summary table and lane configuration diagrams for the two alternatives are included in the appendix.

If you have questions regarding this analysis, or if further analysis is requested, please contact me or Mohammad S. Islam, P.E. at 919-773-2800.

JHD/mpr:msi

Attachments

cc: J. J. Swain, Jr., P.E. (attn. A. G. Henderson, P.E.)
J. S. Goodnight, P.E.
B. D. Taylor, P.E.
J. G. Conforti
E. W. Thomas, P.E. (attn. P. R. Cook, P.E.)
J. K. Lacy, P.E.
T. M. Hopkins, P.E. (attn. D. D. Galloway, P.E.)
G. G. Murr, Jr., P.E., (attn. T. J. Williams, P.E.)
C. L. Evans (attn. E. E. Honeycutt, L. E. Neal)
R. W. King, P.E.
M. R. Reese, P.E.
M. S. Islam, P.E.

TIP I-5501: I-26 and NC 280 (Airport Road) Interchange Analysis Report

The I-26 and NC 280 ramps intersection results for the existing 2011 and design year 2040 (No-build and Build) peak hour results:

2011/2040 Peak Hour Diamond Interchange Analysis Comparisons	2011 No-Build Forecast I-26 4-lane		2011 Build Forecast I-26 6-lane		2011 Build Forecast I-26 8-lane		2040 No-Build Forecast I-26 4-lane		2040 Build Forecast I-26 6-lane		2040 Build Forecast I-26 8-lane	
	EB Ramps AM/PM	WB Ramps AM/PM	EB Ramps AM/PM	WB Ramps AM/PM	EB Ramps AM/PM	WB Ramps AM/PM	EB Ramps AM/PM	WB Ramps AM/PM	EB Ramps AM/PM	WB Ramps AM/PM	EB Ramps AM/PM	WB Ramps AM/PM
Overall Intersection LOS	F/E	D/E	F/E	E/F	F/E	E/F	F/F	F/F	F/F	E/D	E/D	C/C
Worst Movement LOS	F/F	F/F	F/F	F/F	F/F	F/F	F/F	F/F	F/F	E/E	E/E	E/E
Worst Movement V/C Ratio	1.25/1.20	1.15/1.20	1.21/1.1	1.23/1.3	1.19/1.10	1.27/1.3	1.58/1.55	1.49/1.65	0.99/0.98	0.92/0.98	1.00/1.03	0.93/0.99
Synchro 95% Max. Queuing in feet	1000 /950	800/1100	975/ 1100	1050/ 1500	1000/ 1100	1150/ 1500	1650/ 1200	1500/1300	750/550	500/400	850/525	500/425
Intersection Delays in Second	98.3/72.7	45.9/67.3	85.5/ 67.9	61.7/ 86.1	87.4/67.9	65.9/86.1	206.4/ 168.6	134.3/ 167	55.3/ 40.4	29.5/26.5	57.5/42.8	28.9/26.8
No of Lanes on Bridge	6	6	6	6	6	6	6	6	7	7	7	7
Widen Bridge?	No	No	No	No	No	No	No	No	Yes	Yes	Yes	Yes

* Widen the bridge to 7-lane for traditional Diamond Interchange. ** m, #, and m# signs are omitted from Synchro 95% Maximum Queuing

2011/2040 Peak Hour Diverging Diamond Interchange (DDI) Analysis Comparisons	2011 Build Forecast I-26 6-lane		2011 Build Forecast I-26 8-lane		2040 No-Build Forecast I-26 4-lane		2040 Build Forecast I-26 6-lane		2040 Build Forecast I-26 8-lane	
	EB Ramps AM/PM	WB Ramps AM/PM	EB Ramps AM/PM	WB Ramps AM/PM	EB Ramps AM/PM	WB Ramps AM/PM	EB Ramps AM/PM	WB Ramps AM/PM	EB Ramps AM/PM	WB Ramps AM/PM
Overall Intersection LOS	B/C	C/C	B/C	C/C	C/C	D/C	C/C	C/B	C/C	C/B
Worst Movement LOS	C/C	D/C	C/C	D/C	D/D	D/D	D/D	C/C	D/D	D/C
Worst Movement V/C Ratio	0.77/0.82	0.93/0.86	0.80/0.82	0.94/0.86	0.82/0.95	1.02/0.91	0.83/0.97	0.96/0.85	0.86/0.99	0.95/0.85
Synchro 95% Max. Queuing in feet	400/450	675/450	425/475	675/450	420/600	675/500	525/700	650/450	550/750	650/425
Intersection Delays in Second	18.5/22.3	30.2/21.1	18.4/22.3	30.1/20.5	22.7/30.7	49.9/23	22/30.7	31.9/19.4	21.4/33.8	34.3/19.6
No of Lanes on Bridge	6	6	6	6	6	6	6	6	6	6
Widen Bridge?	No	No	No	No	No	No	No	No	No	No

Note: Five vehicular lanes and a 6th in center for pedestrian/median for DDI. *** m, #, and m# signs are omitted from Synchro 95% Maximum Queuing

2040 Build (6 lanes and 8 lanes)

I-5501 (I-26 and NC 280 Interchange)

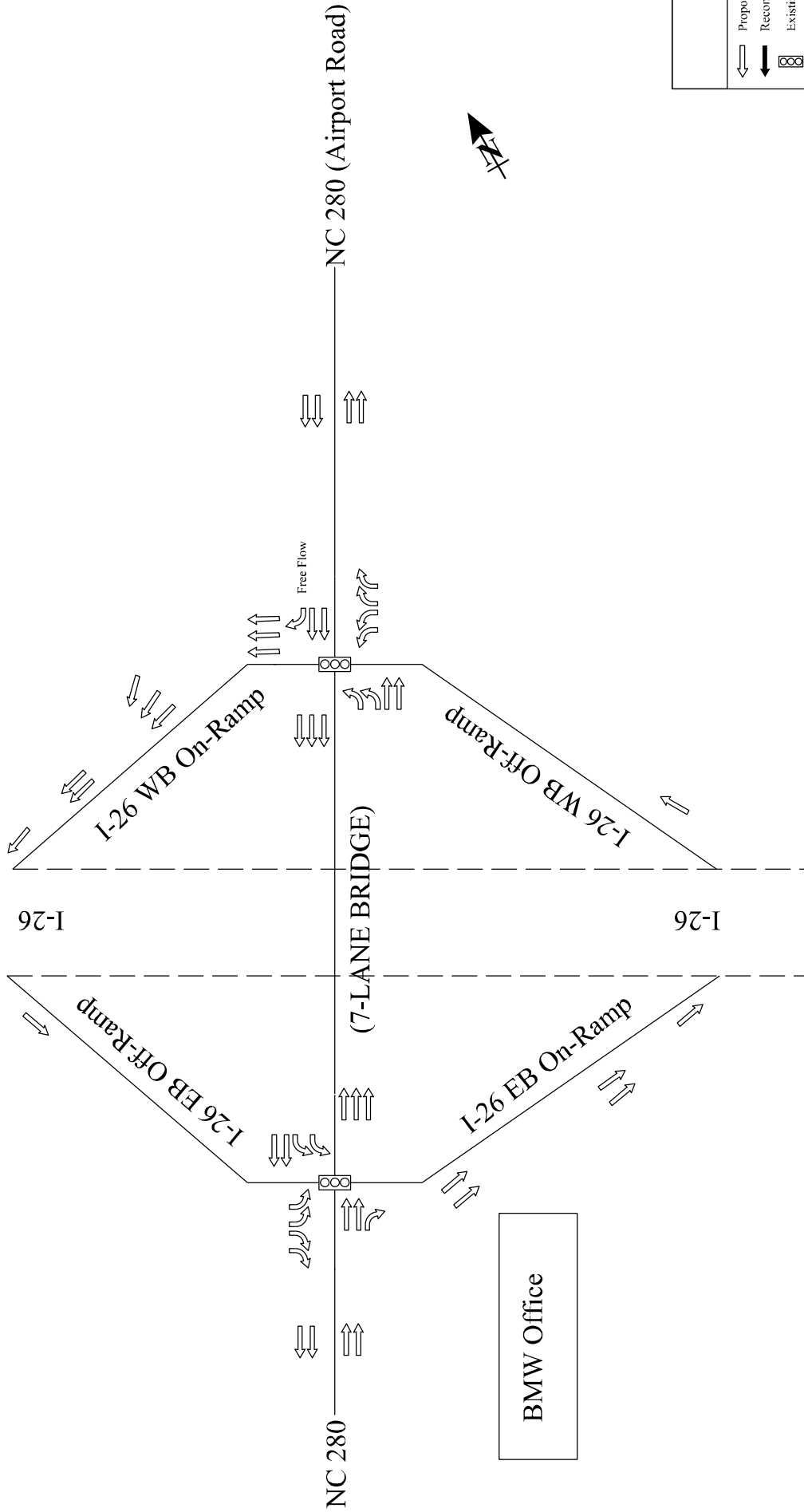

Fig: 2040-Build Diamond Interchange
*** Bridge needs to wide (7-lane Bridge)**

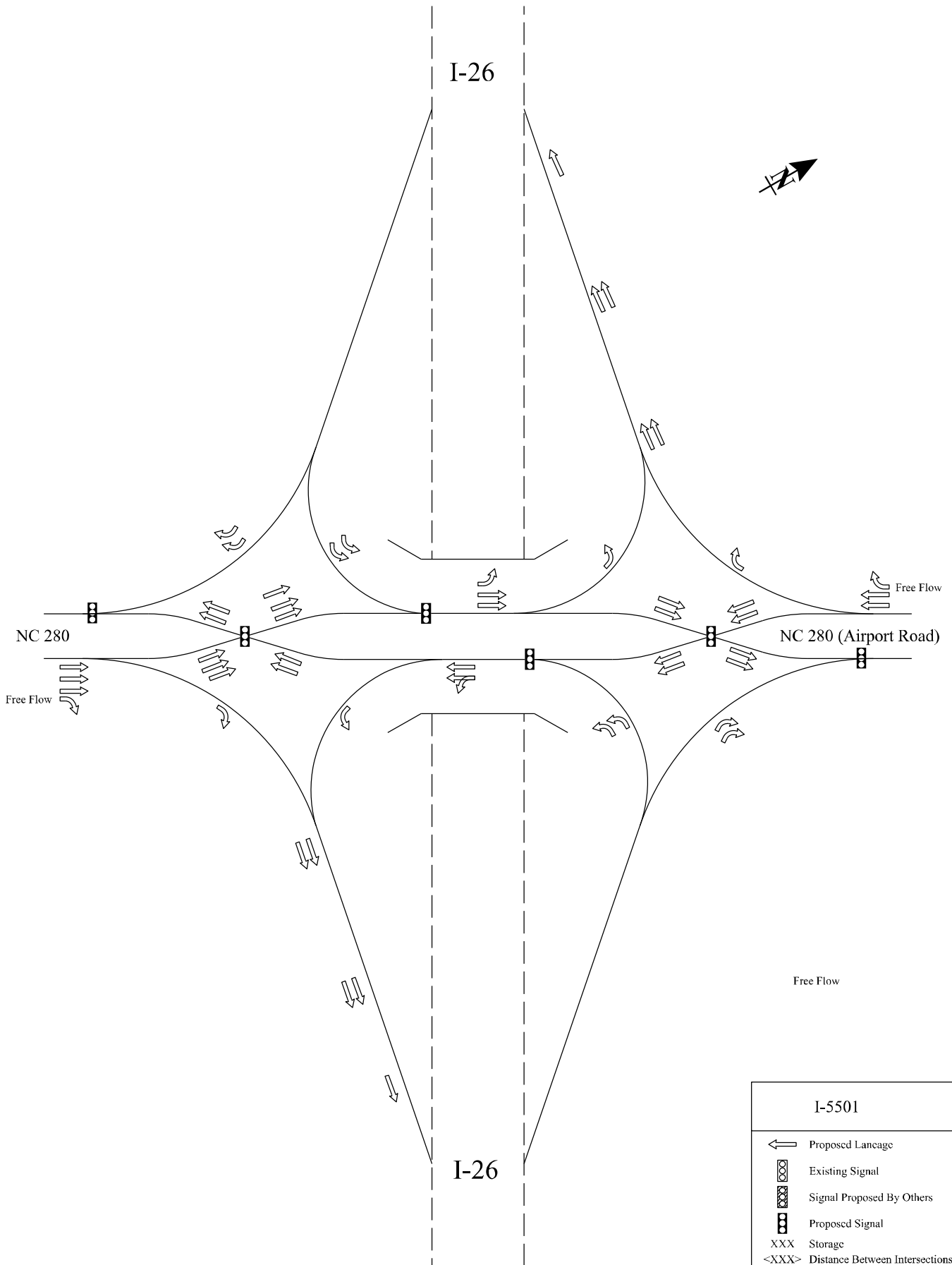
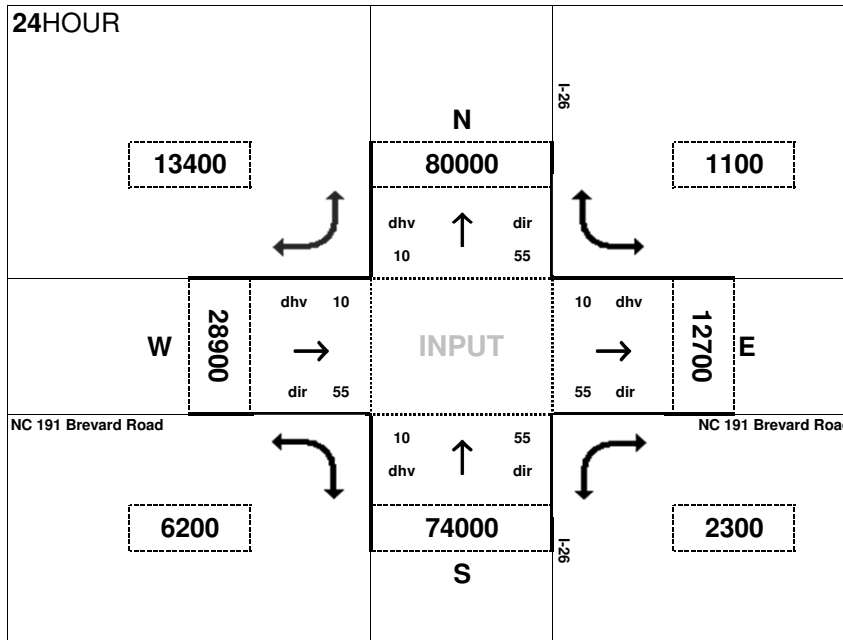

Fig: 2040 Diverging Diamond Interchange (DDI)

I-5501	
	Proposed Laneage
	Existing Signal
	Signal Proposed By Others
	Proposed Signal
XXX	Storage
<XXX>	Distance Between Intersections
IPS	Internal Protected Stem
All Distances in Feet	
Drawing Not to Scale	
Not for Construction	

Appendix G – 2040 Peak Hour Breakouts

2011 No-Build



Peak Hour Volume Breakouts Report:
6. I-26 & NC 191 Interchange

Traffic Forecast Release Date:
February-12

Traffic Data Year:
2011 BY - No-Build

Project:
STIP I-4400/4700 - I-26 Widening

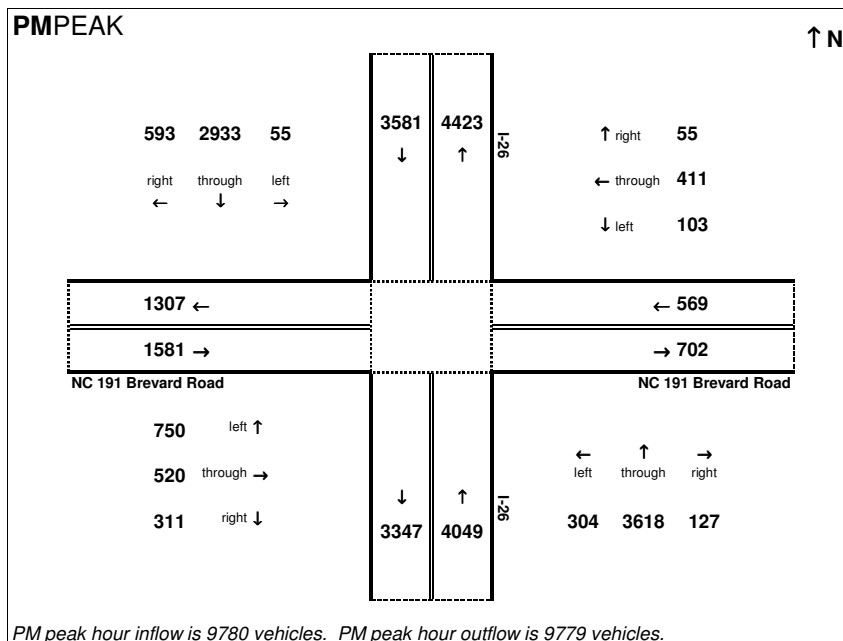
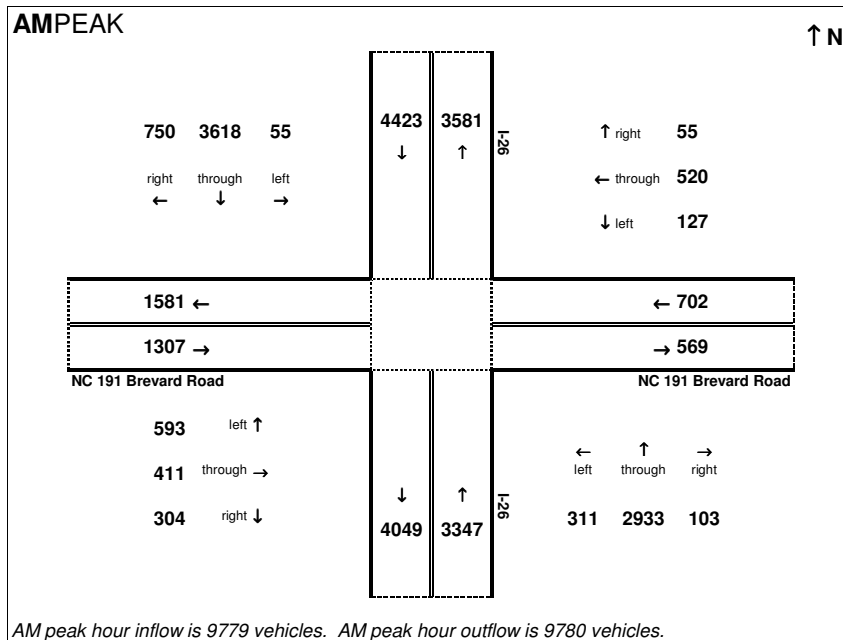

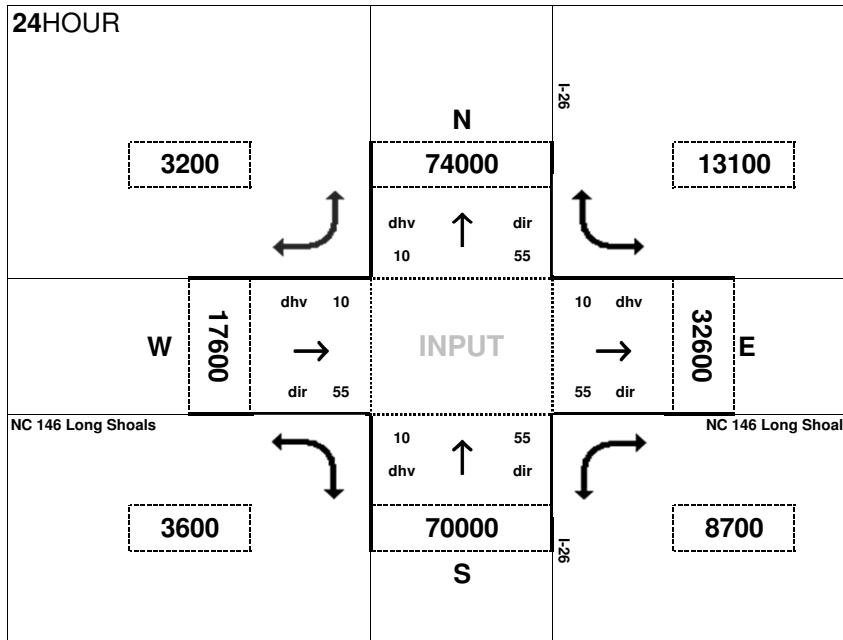

Peak Hour Volume Breakouts Report:
7. I-26 & NC 146 Interchange

Traffic Forecast Release Date:
February-12

Traffic Data Year:
2011 BY - No-Build

Project:
STIP I-4400/4700 - I-26 Widening

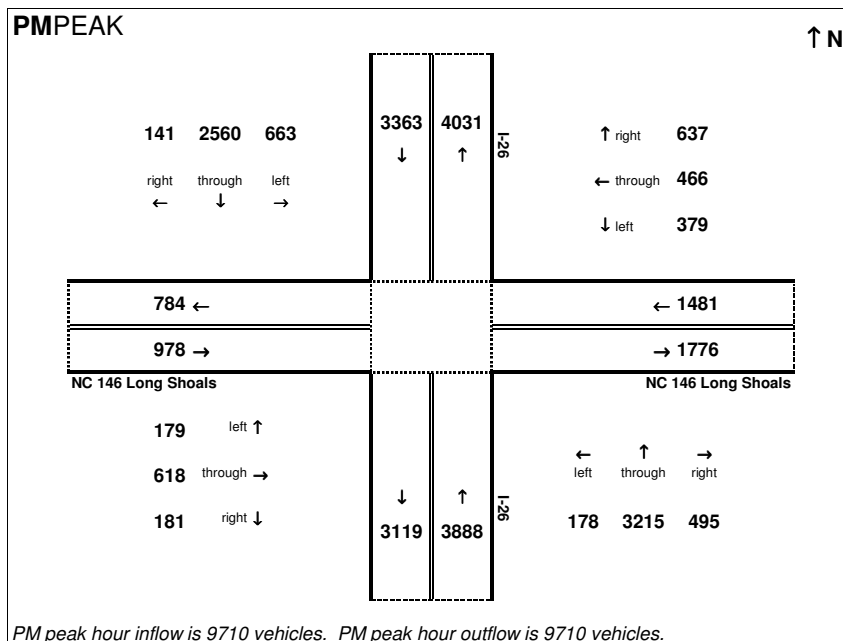
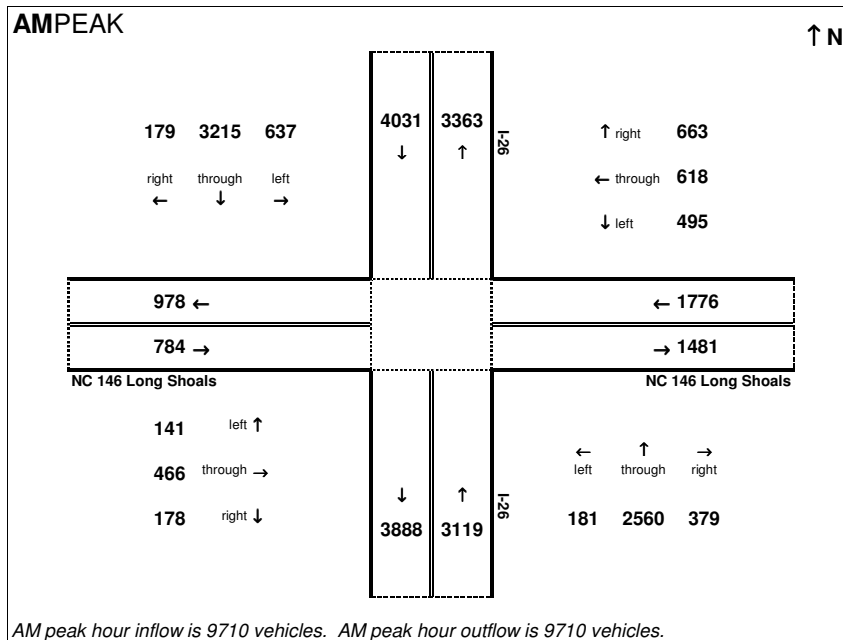

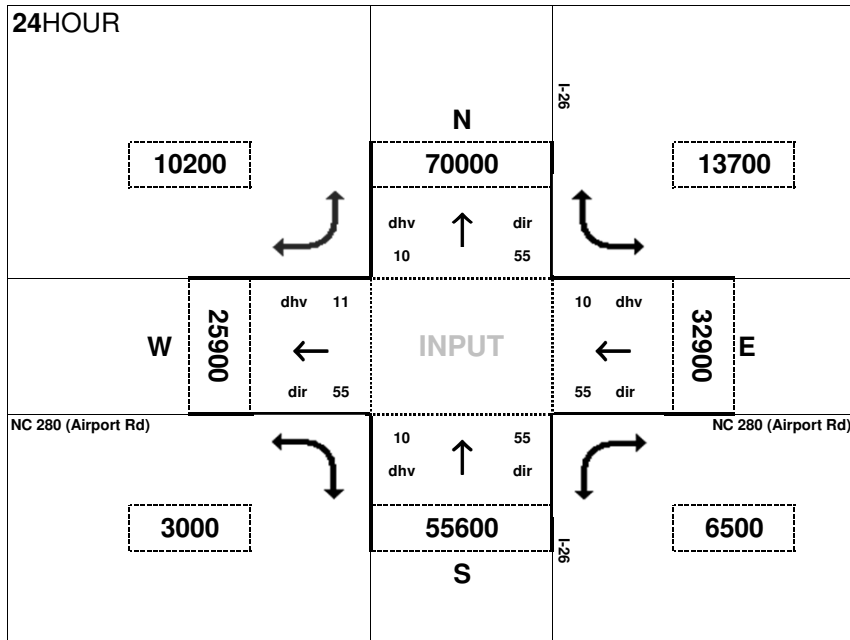

Peak Hour Volume Breakouts Report:
8. I-26 & NC 280 Interchange

Traffic Forecast Release Date:
February-12

Traffic Data Year:
2011 BY - No-Build

Project:
STIP I-4400/4700 - I-26 Widening

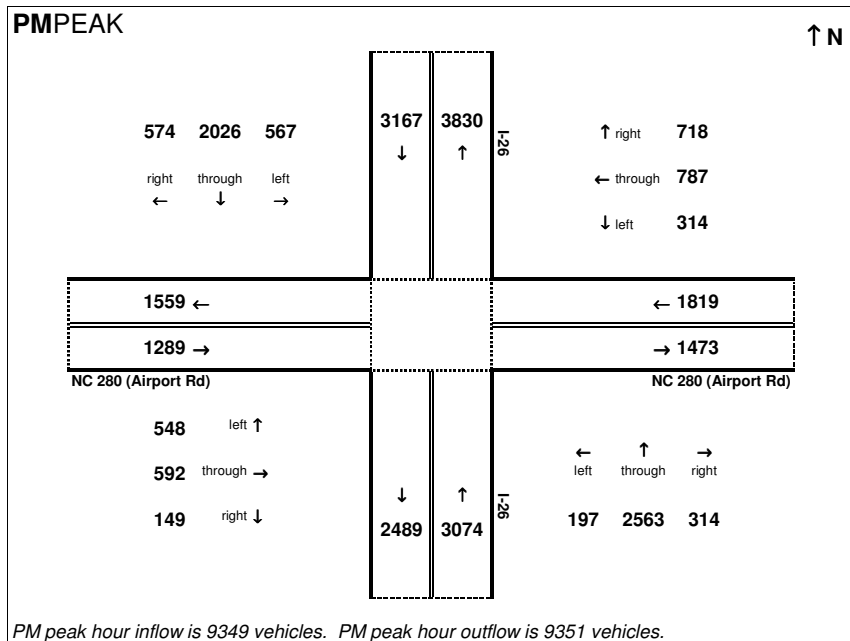
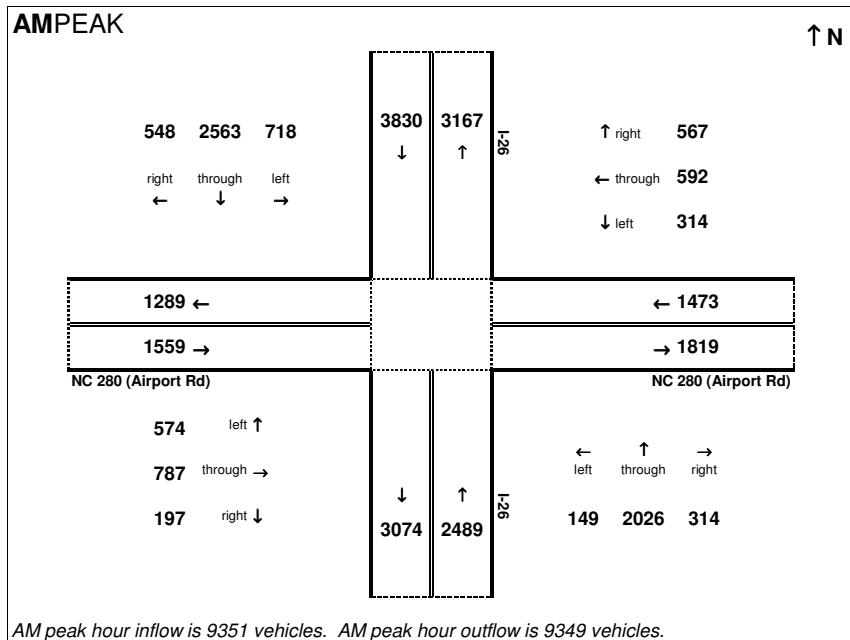

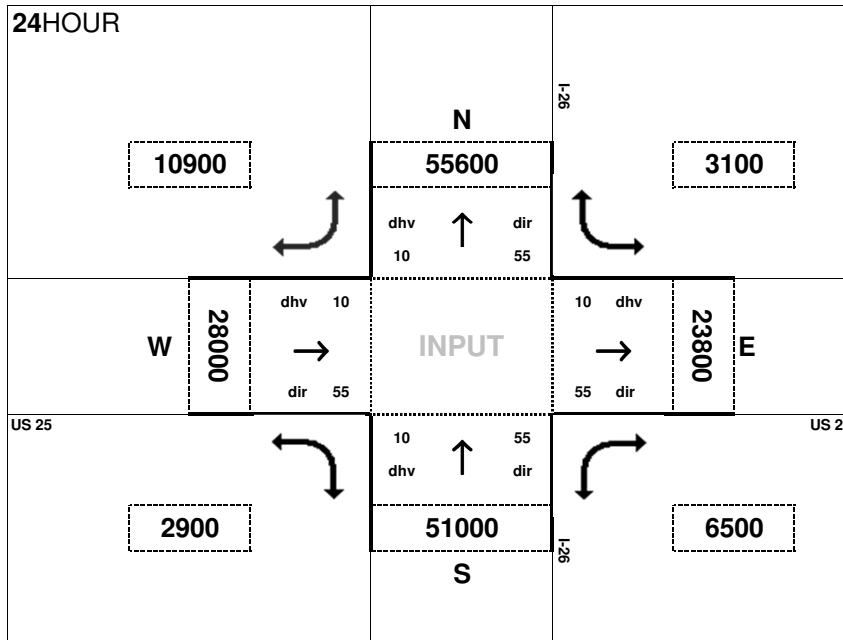

Peak Hour Volume Breakouts Report:
10. I-26 & US 25 Interchange

Traffic Forecast Release Date:
February-12

Traffic Data Year:
2011 BY - No-Build

Project:
STIP I-4400/4700 - I-26 Widening

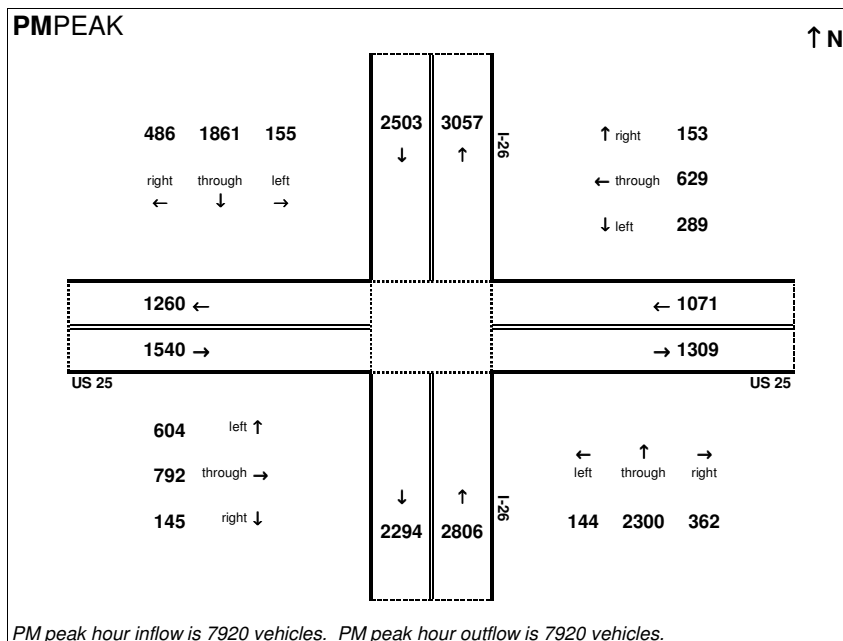
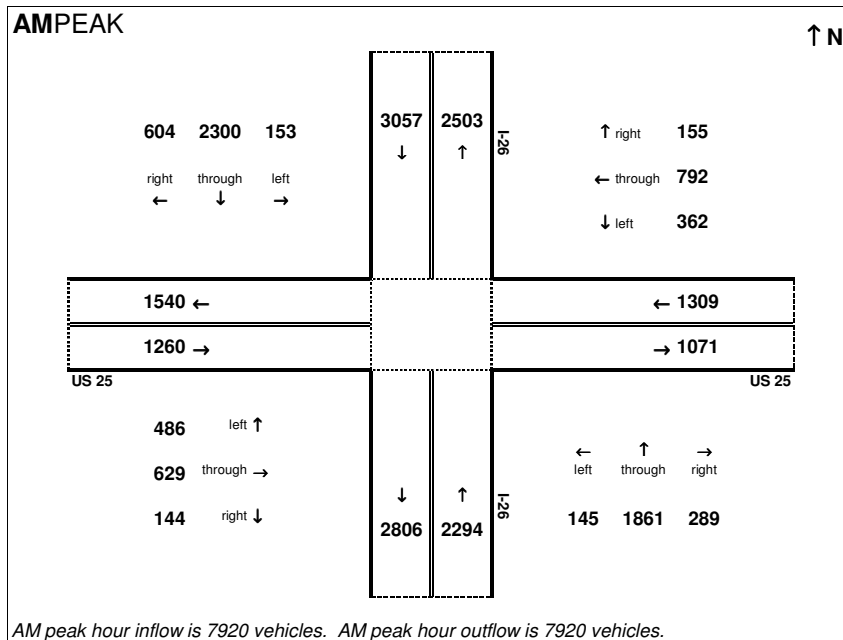

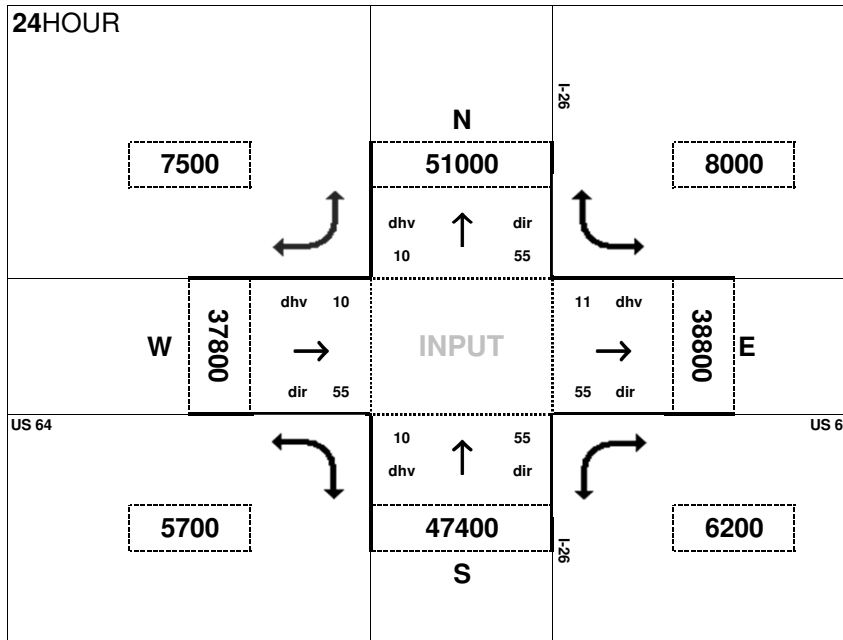

Peak Hour Volume Breakouts Report:
12. I-26 & US 64 System Interchange

Traffic Forecast Release Date:
February-12

Traffic Data Year:
2011 BY - No-Build

Project:
STIP I-4400/4700 - I-26 Widening

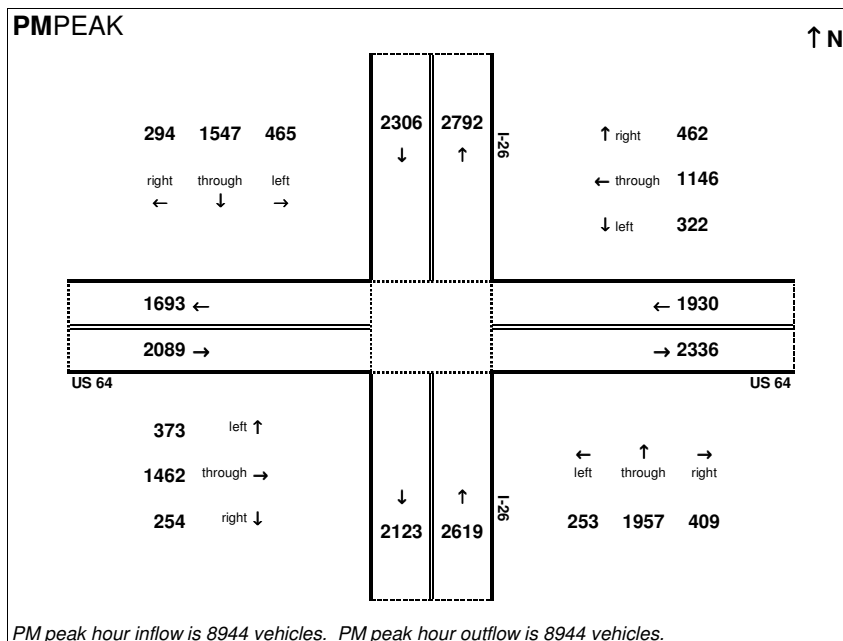
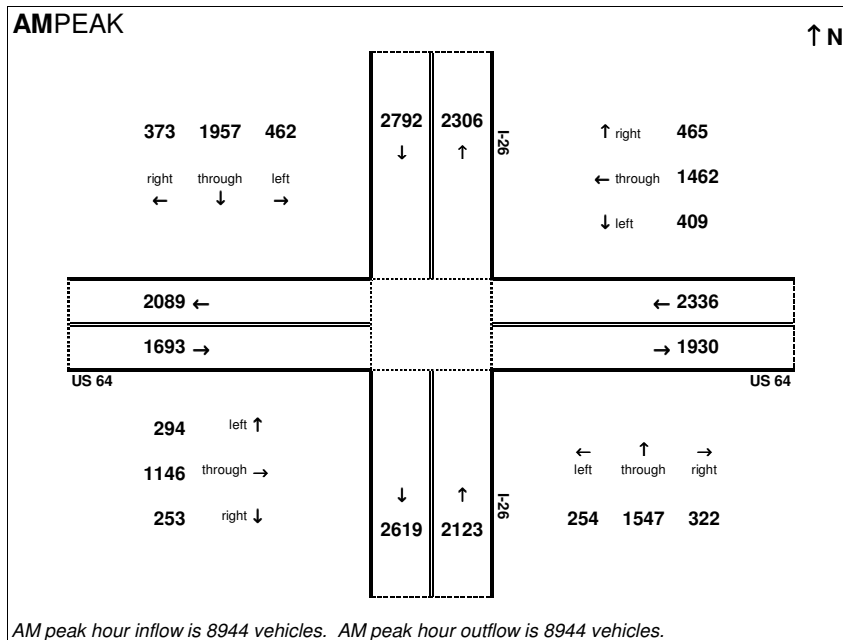

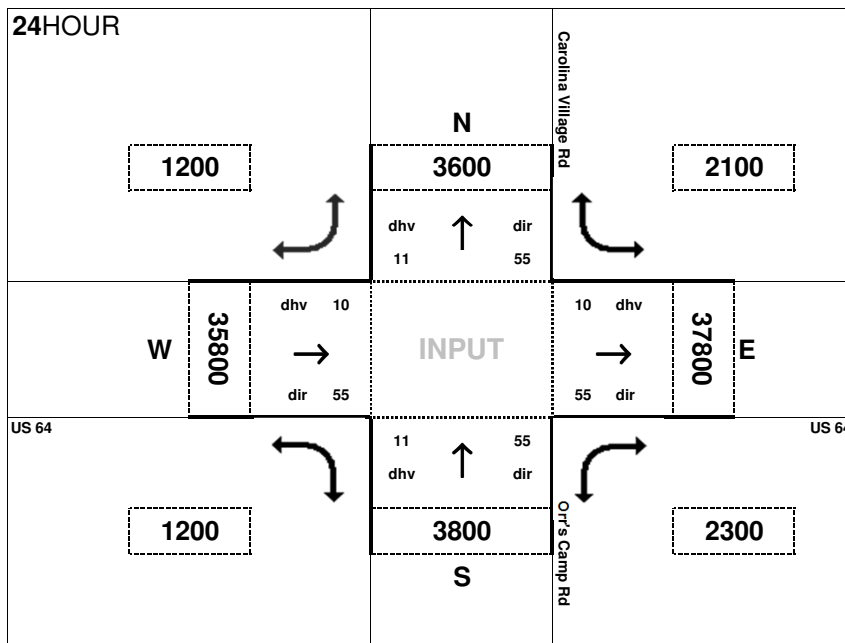

Peak Hour Volume Breakouts Report:

12a. US 64 & Carolina Village Rd / Orr's Camp Rd

Traffic Forecast Release Date:

February-12

Traffic Data Year:

2011 BY - No-Build

Project:

STIP I-4400/4700 - I-26 Widening

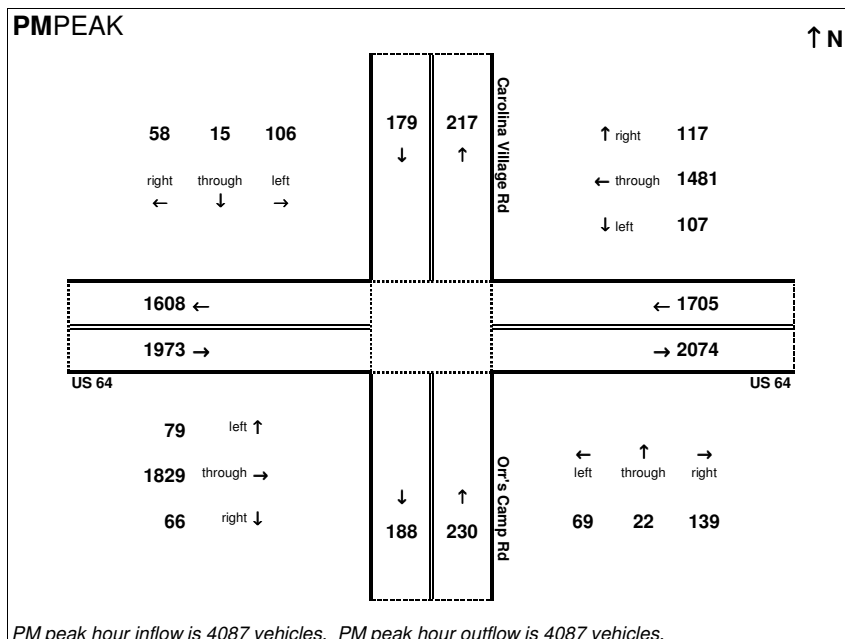
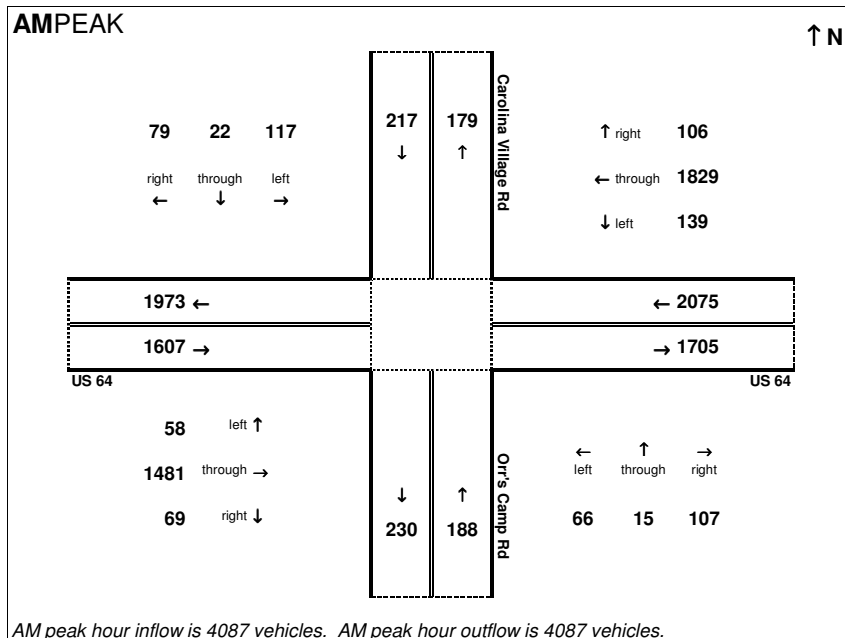

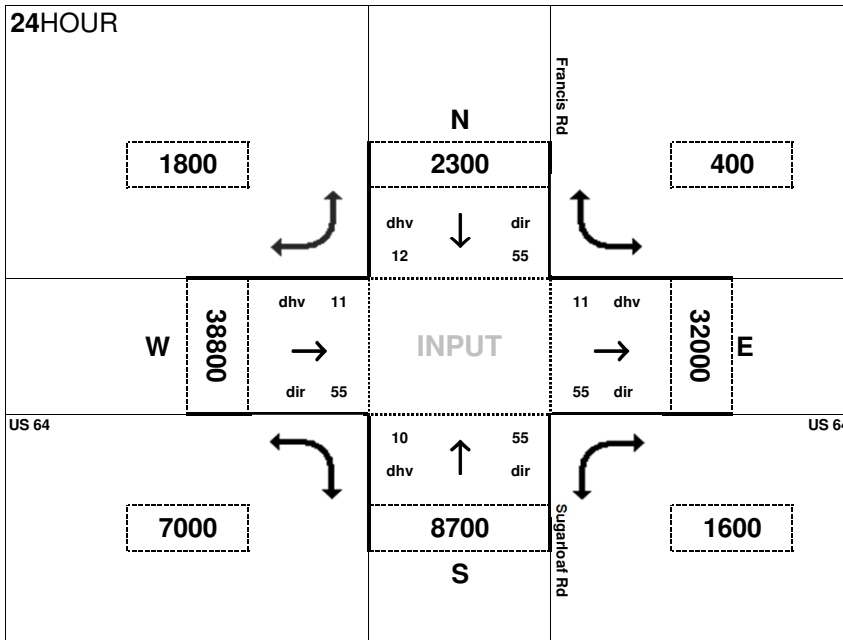

Peak Hour Volume Breakouts Report:
12b. US 64 & Francis Rd / Sugarloaf Rd

Traffic Forecast Release Date:
February-12

Traffic Data Year:
2011 BY - No-Build

Project:
STIP I-4400/4700 - I-26 Widening

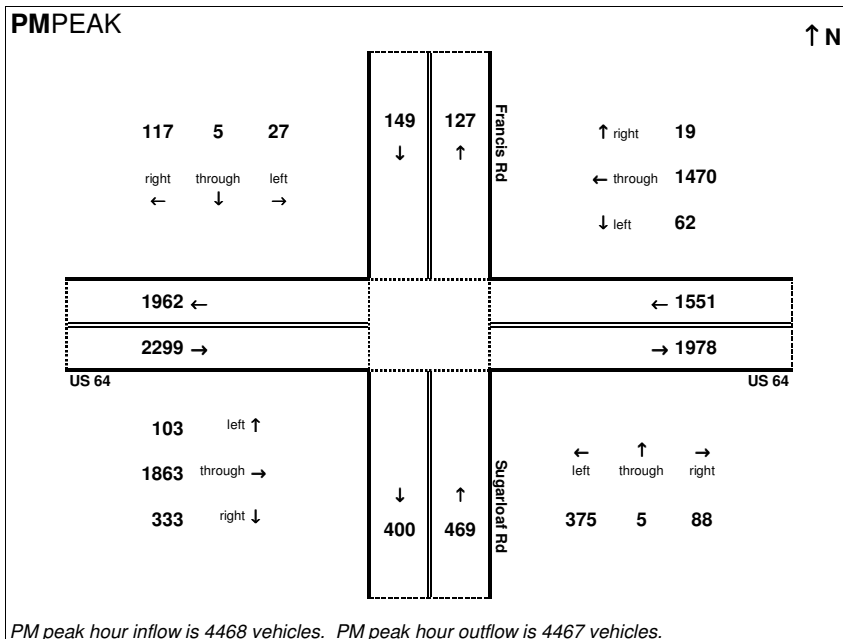
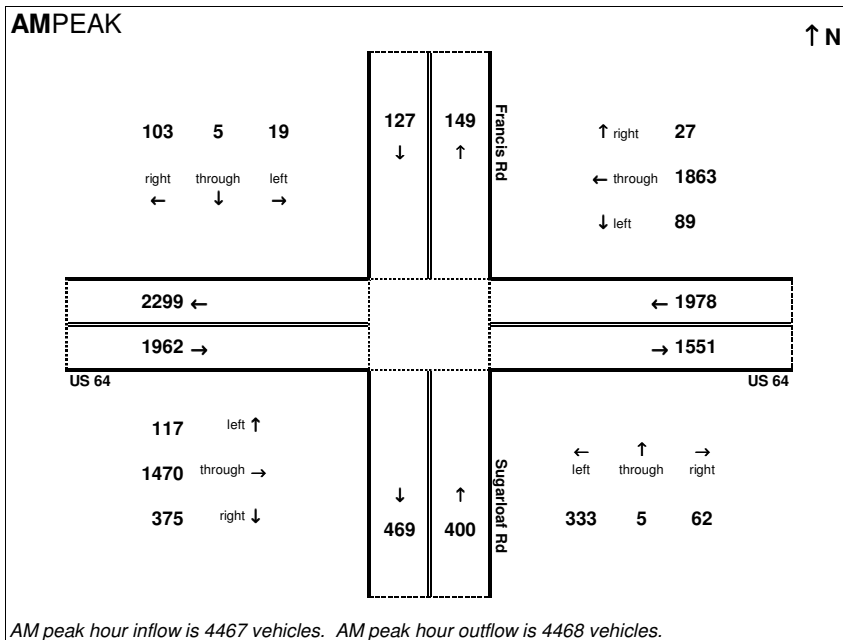

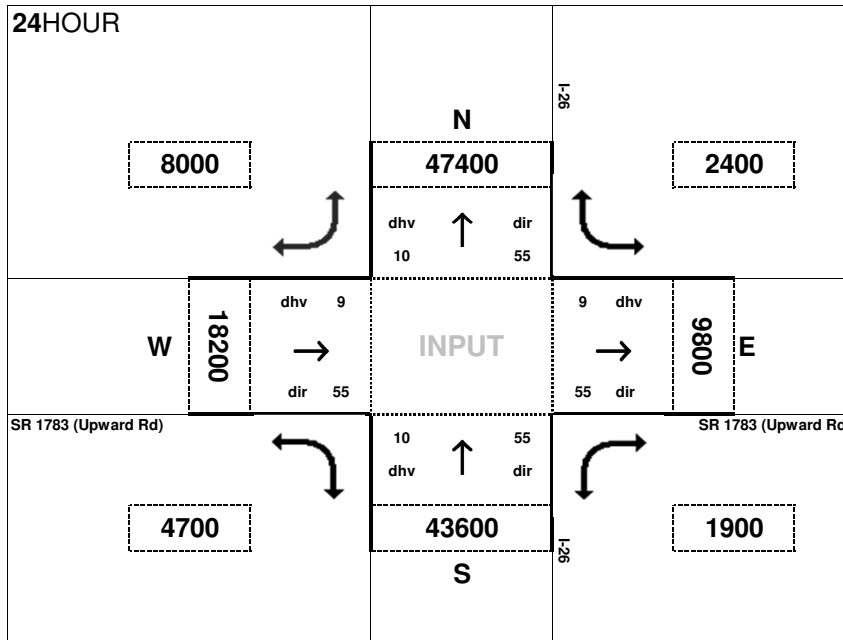

Peak Hour Volume Breakouts Report:
13. I-26 & Upward Road Interchange

Traffic Forecast Release Date:
February-12

Traffic Data Year:
2011 BY - No-Build

Project:
STIP I-4400/4700 - I-26 Widening

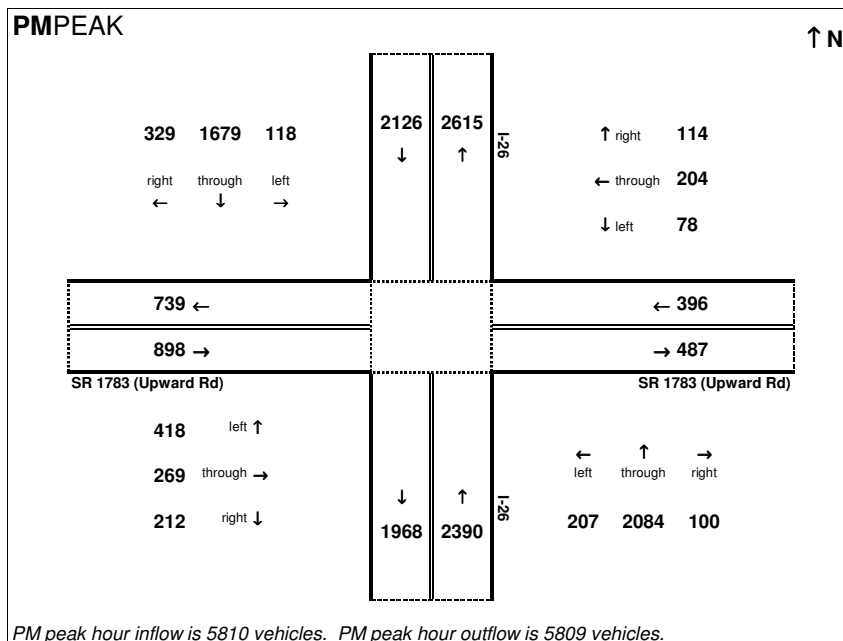
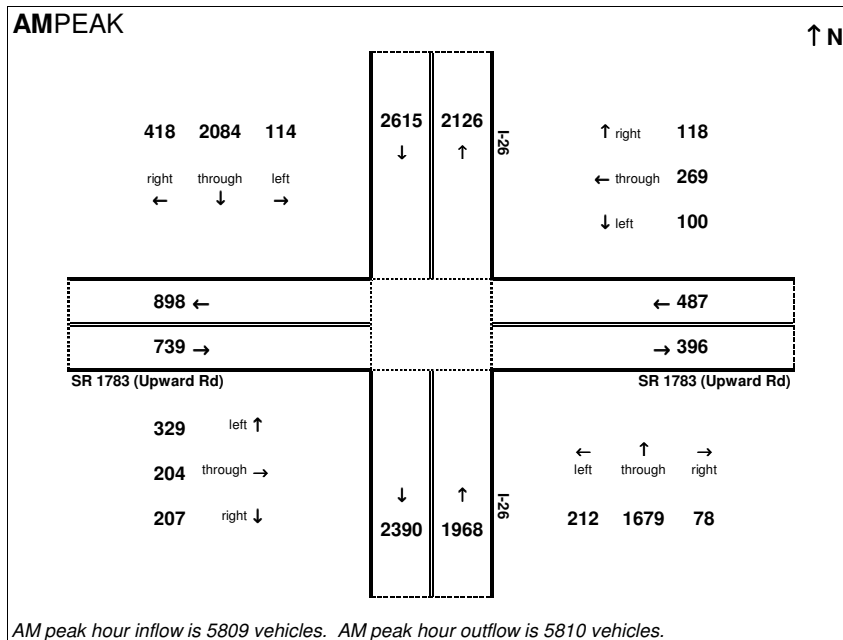

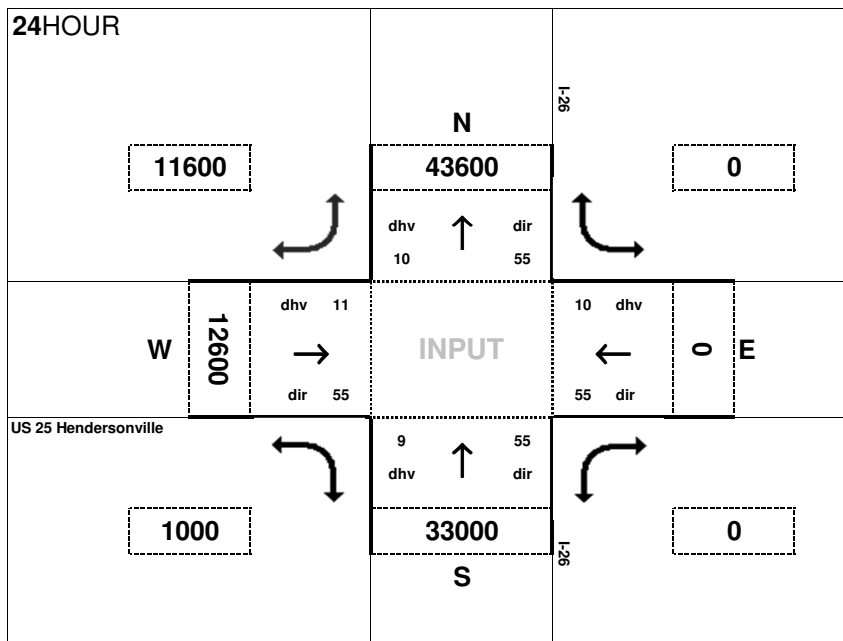

Peak Hour Volume Breakouts Report:
14. I-26 & US 25 Hendersonville Interchange

Traffic Forecast Release Date:
February-12

Traffic Data Year:
2011 BY - No-Build

Project:
STIP I-4400/4700 - I-26 Widening

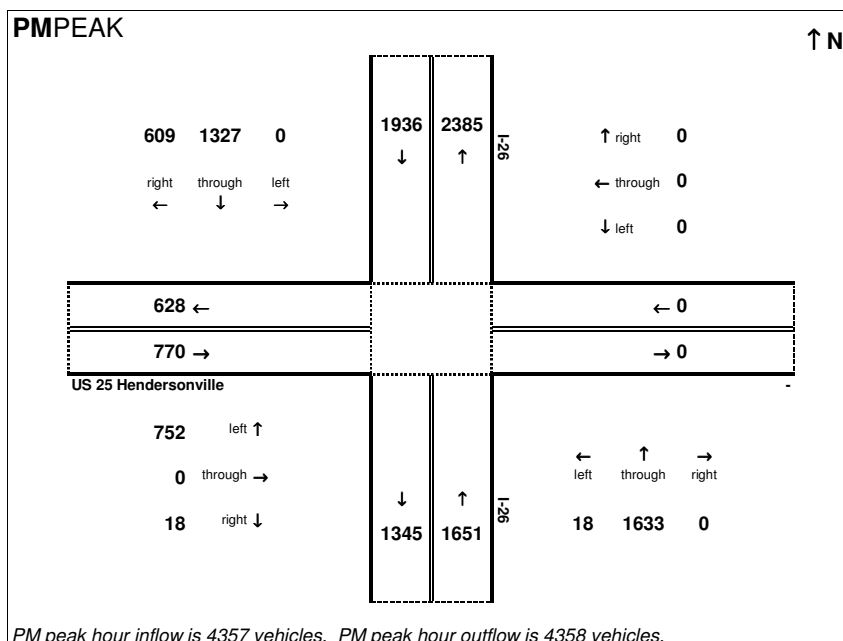
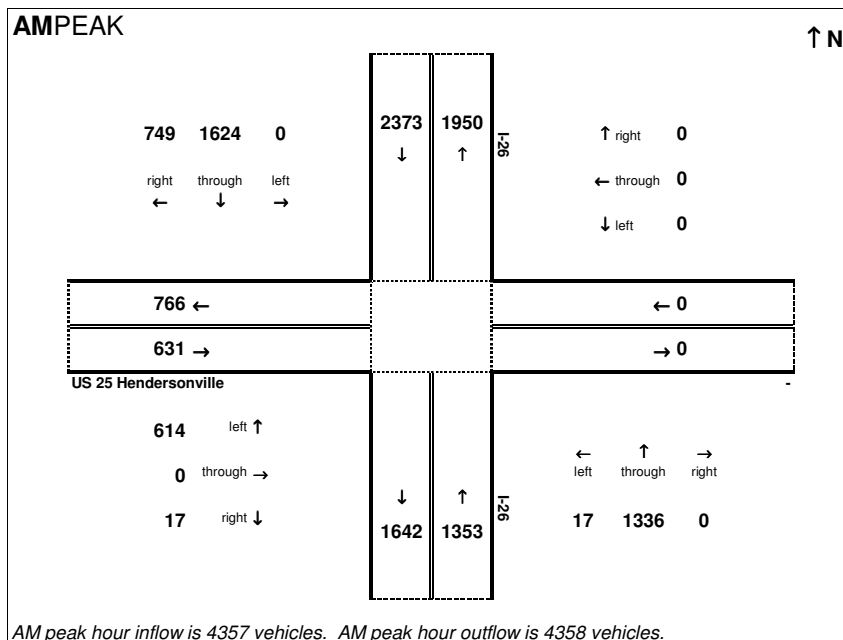

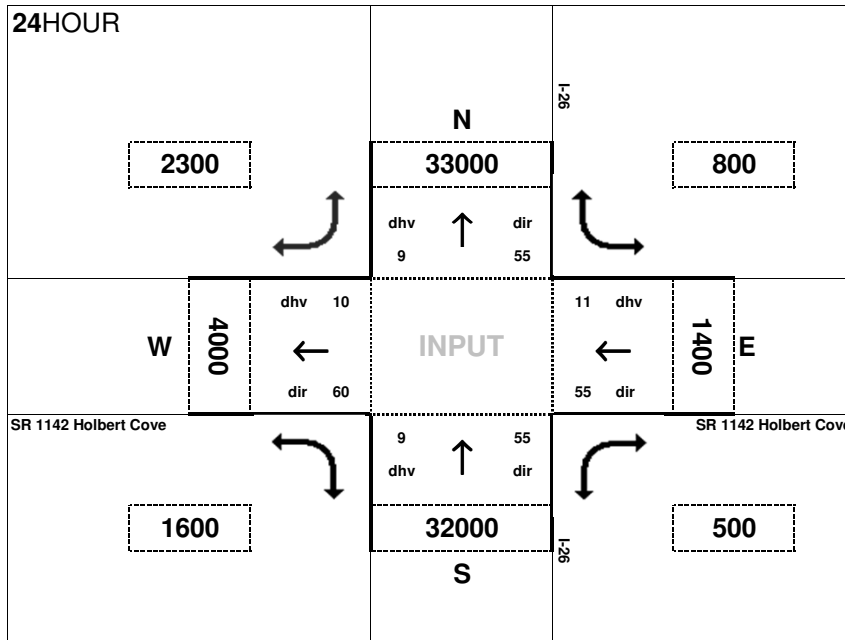

Peak Hour Volume Breakouts Report:
15. I-26 & Holbert Cove Rd Interchange

Traffic Forecast Release Date:
February-12

Traffic Data Year:
2011 BY - No-Build

Project:
STIP I-4400/4700 - I-26 Widening

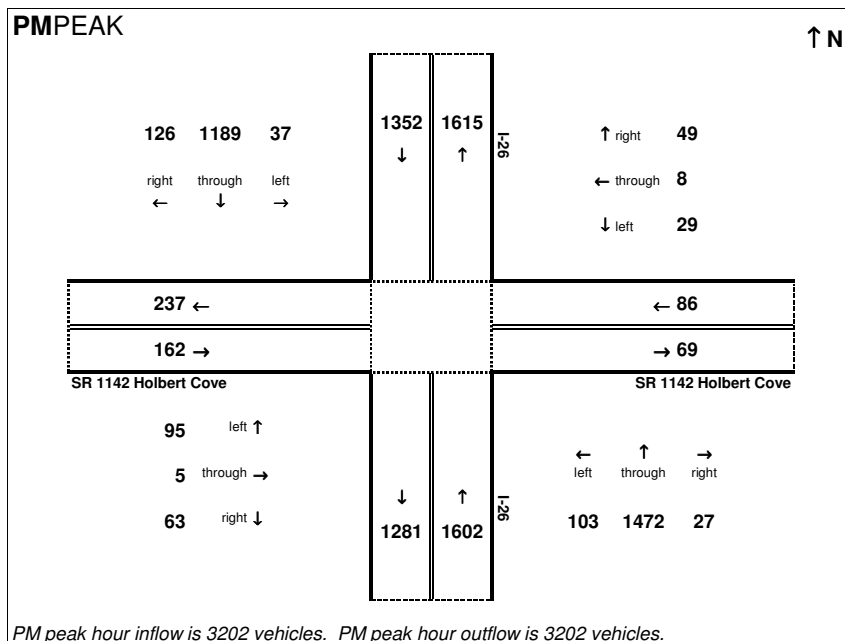
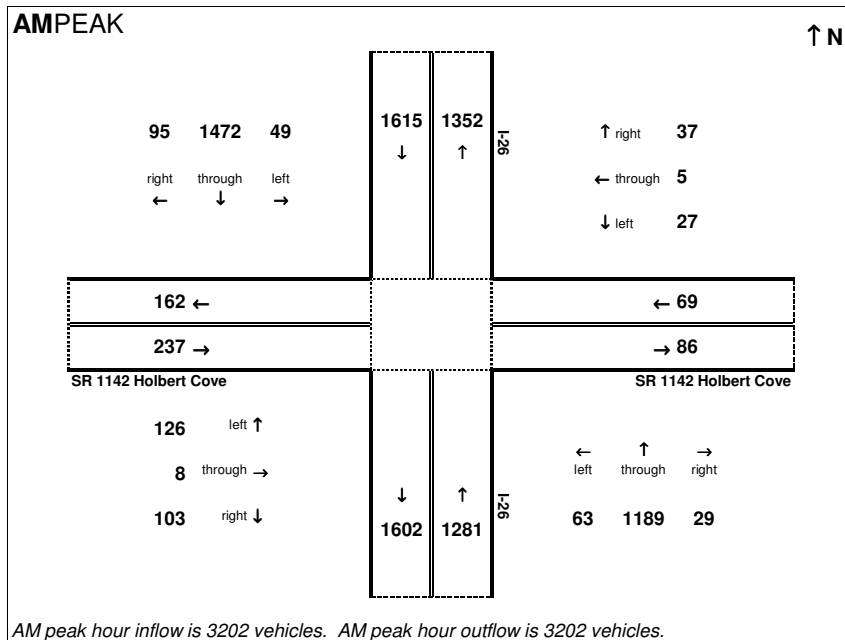

2011 Build 6 Lane

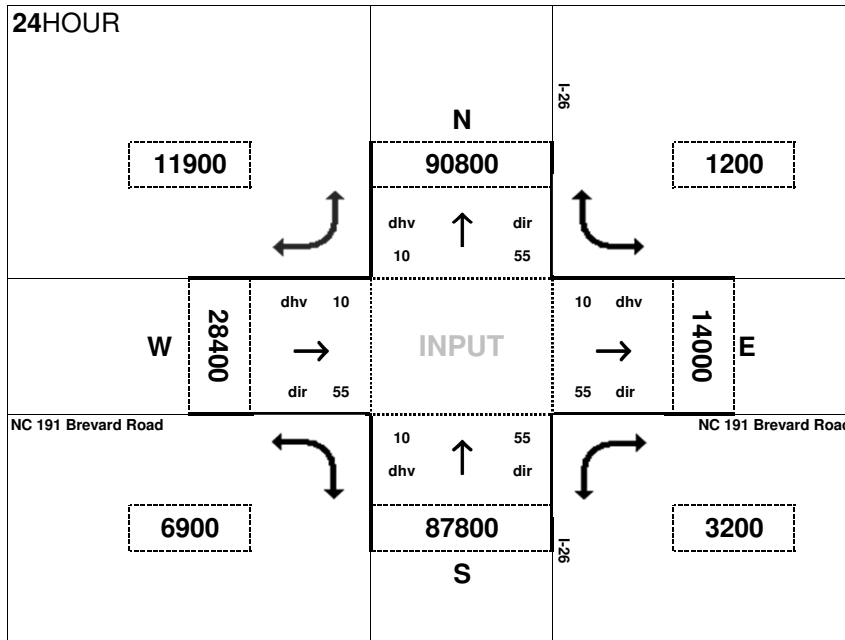

Peak Hour Volume Breakouts Report:
6. I-26 & NC 191 Interchange

Traffic Forecast Release Date:
February-12

Traffic Data Year:
2011 BY - Build 6 Ln

Project:
STIP I-4400/4700 - I-26 Widening

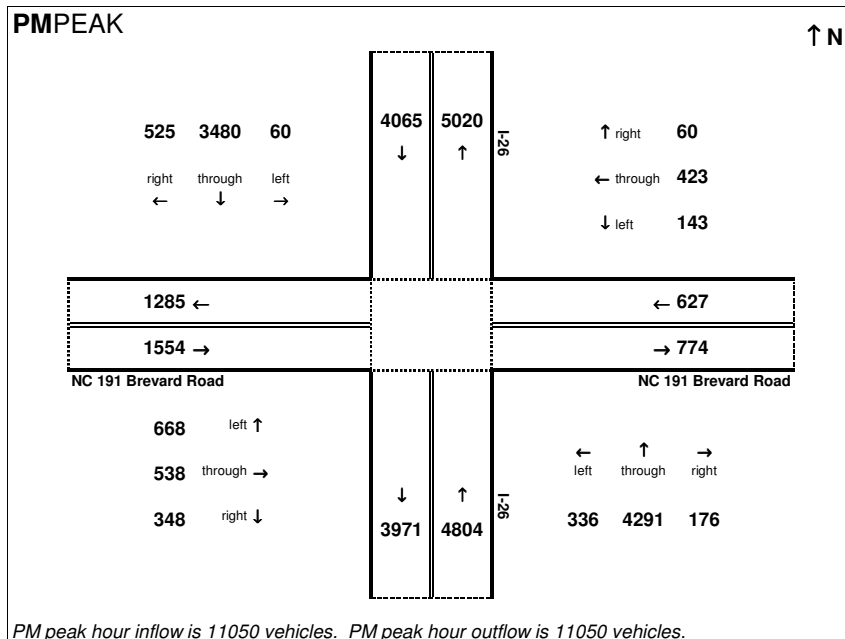
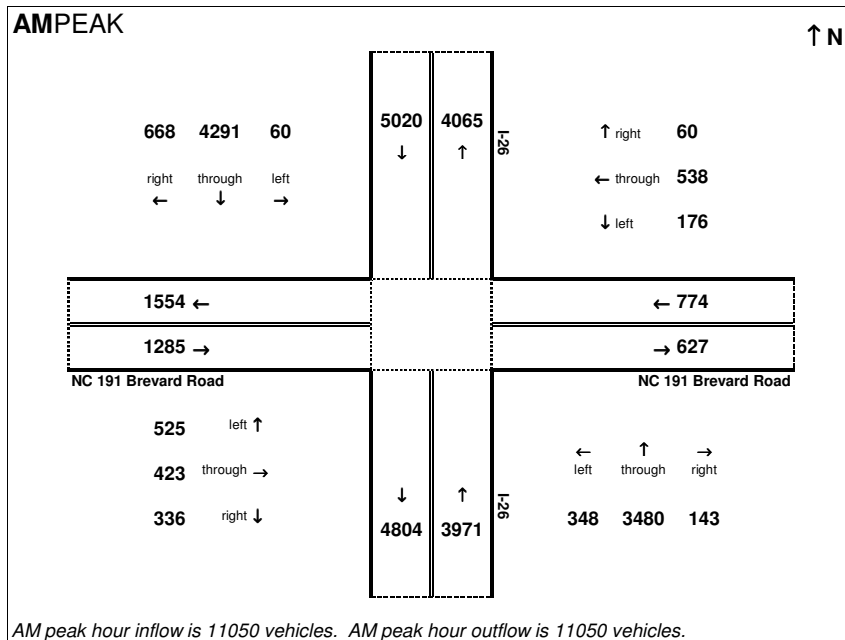

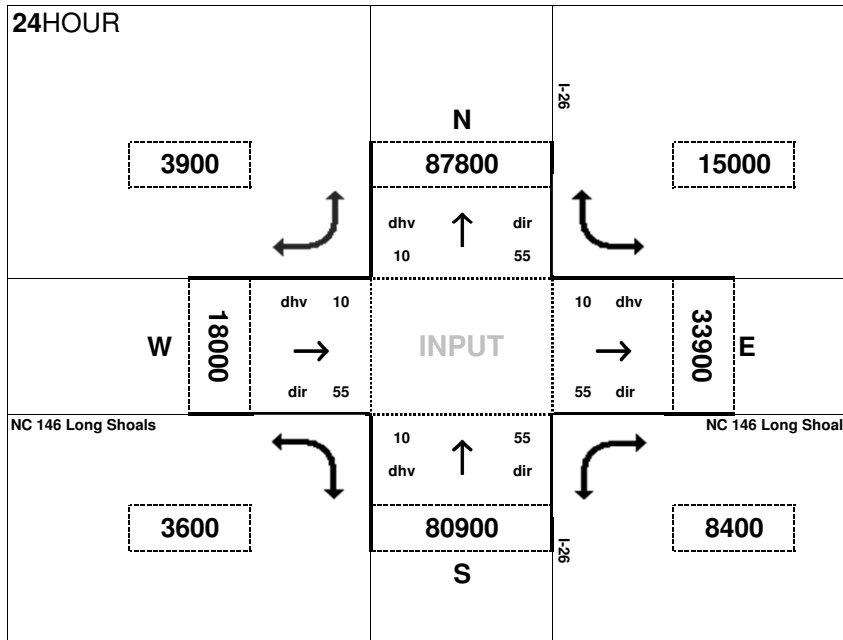

Peak Hour Volume Breakouts Report:
7. I-26 & NC 146 Interchange

Traffic Forecast Release Date:
February-12

Traffic Data Year:
2011 BY - Build 6 Ln

Project:
STIP I-4400/4700 - I-26 Widening

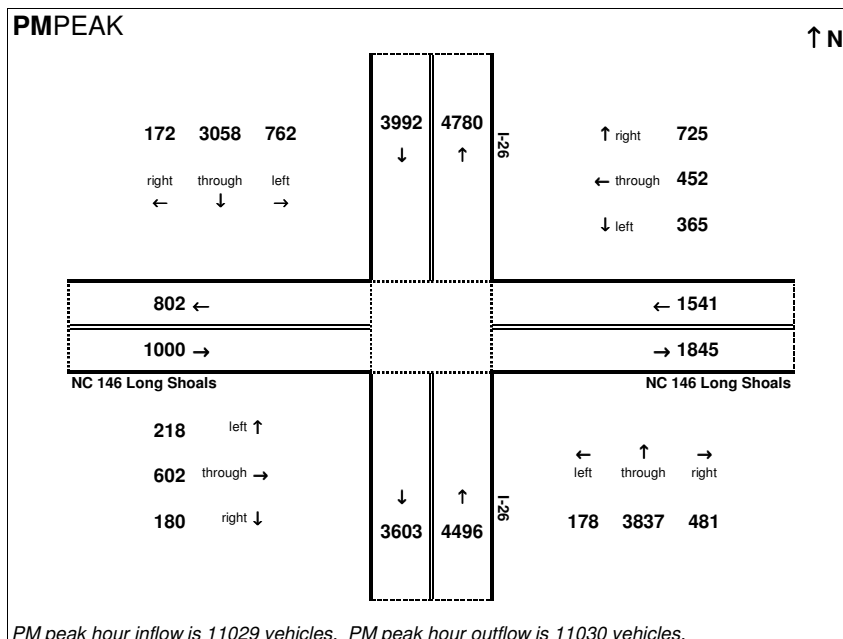
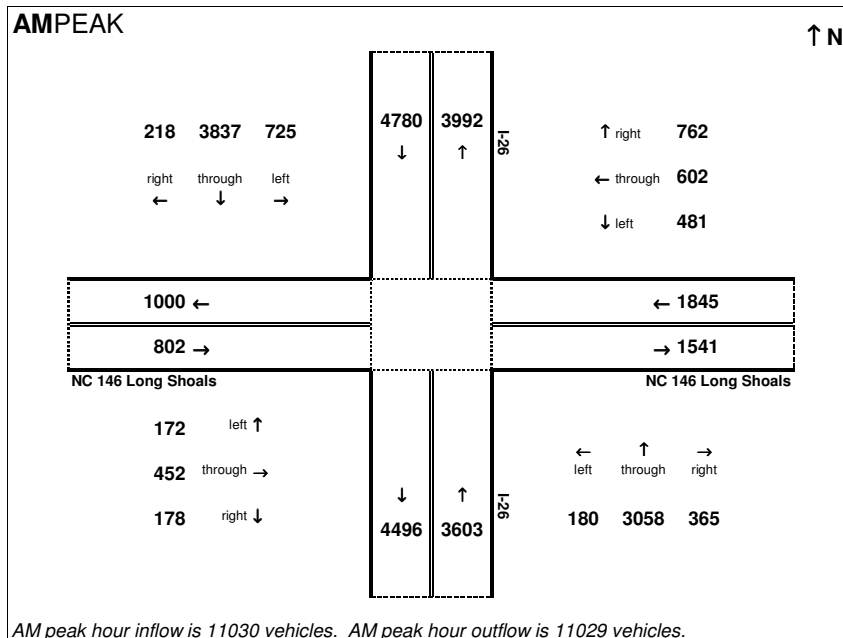

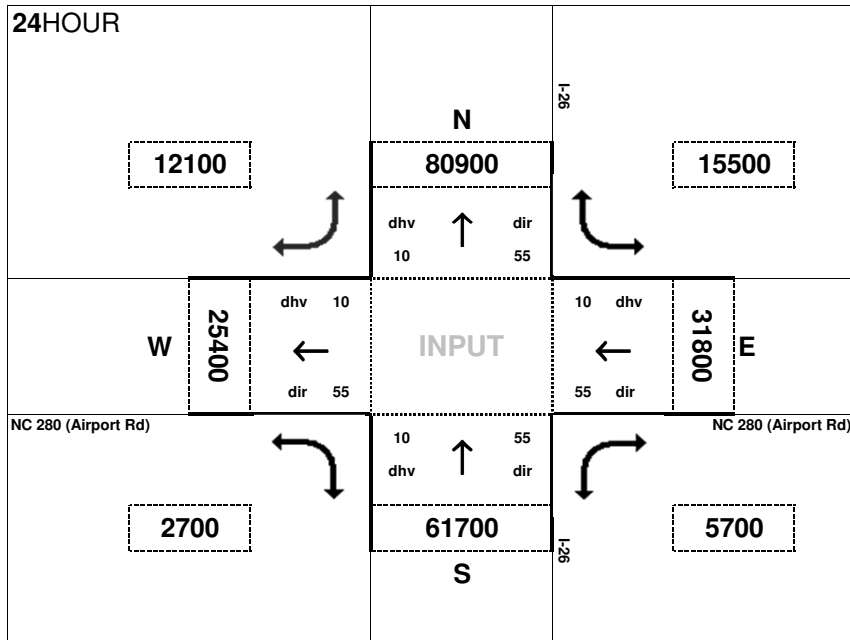

Peak Hour Volume Breakouts Report:
8. I-26 & NC 280 Interchange

Traffic Forecast Release Date:
February-12

Traffic Data Year:
2011 BY - Build 6 Ln

Project:
STIP I-4400/4700 - I-26 Widening

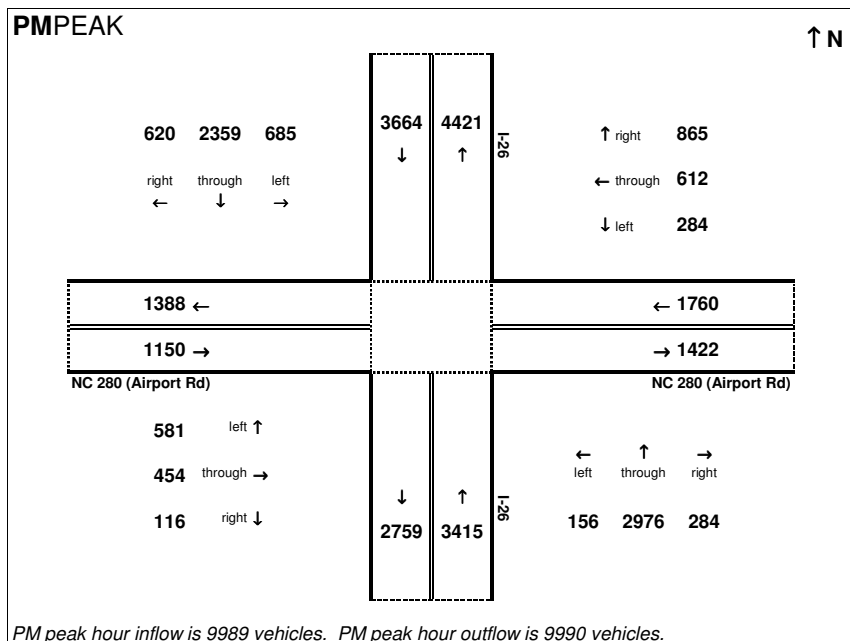
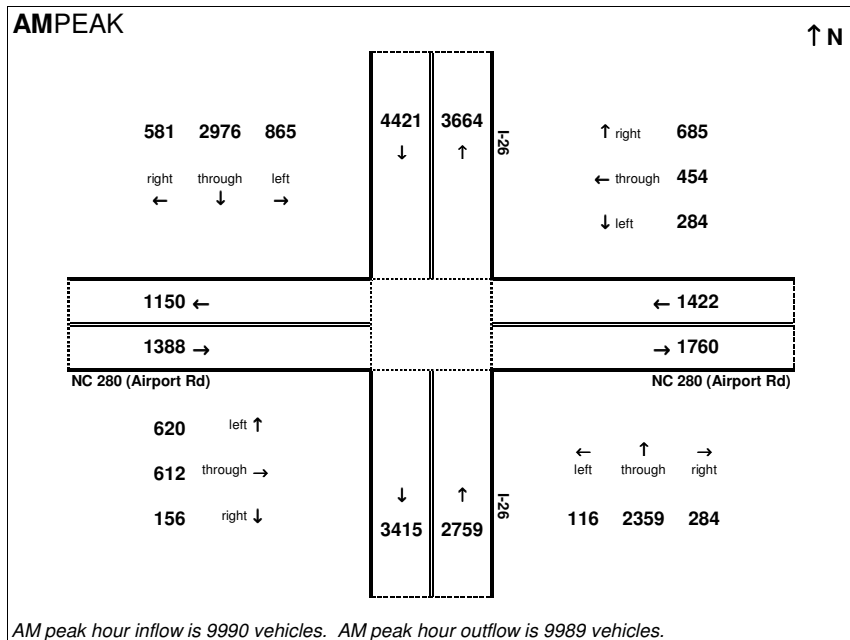

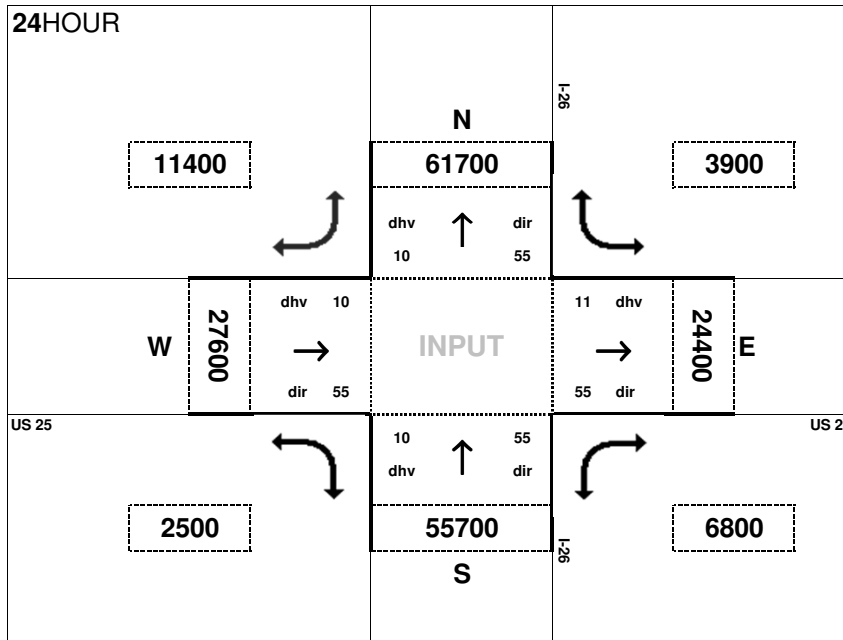

Peak Hour Volume Breakouts Report:
10. I-26 & US 25 Interchange

Traffic Forecast Release Date:
February-12

Traffic Data Year:
2011 BY - Build 6 Ln

Project:
STIP I-4400/4700 - I-26 Widening

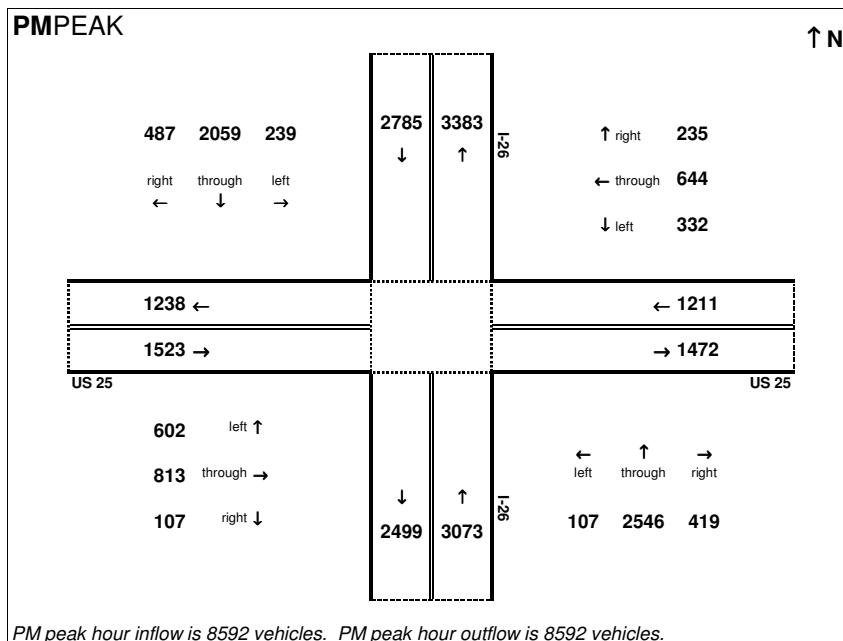
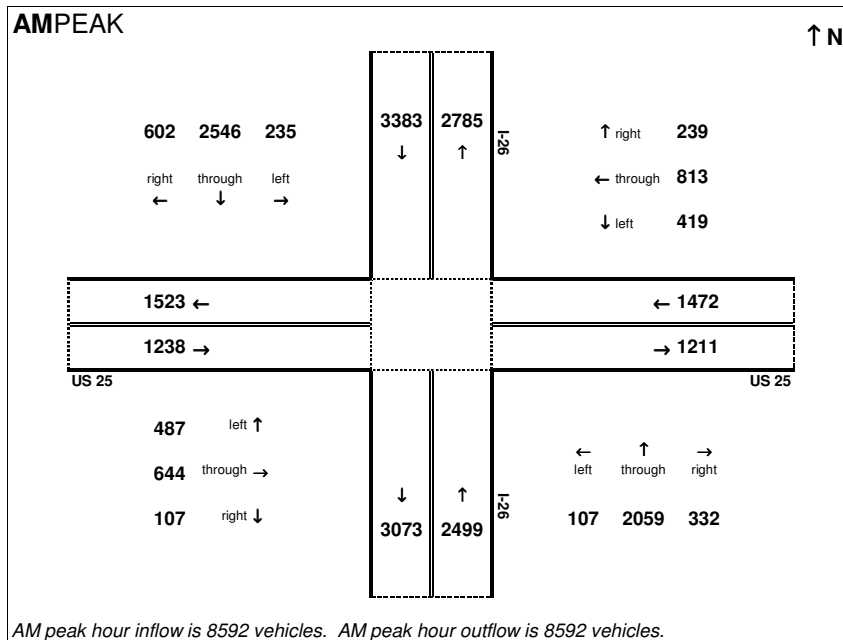

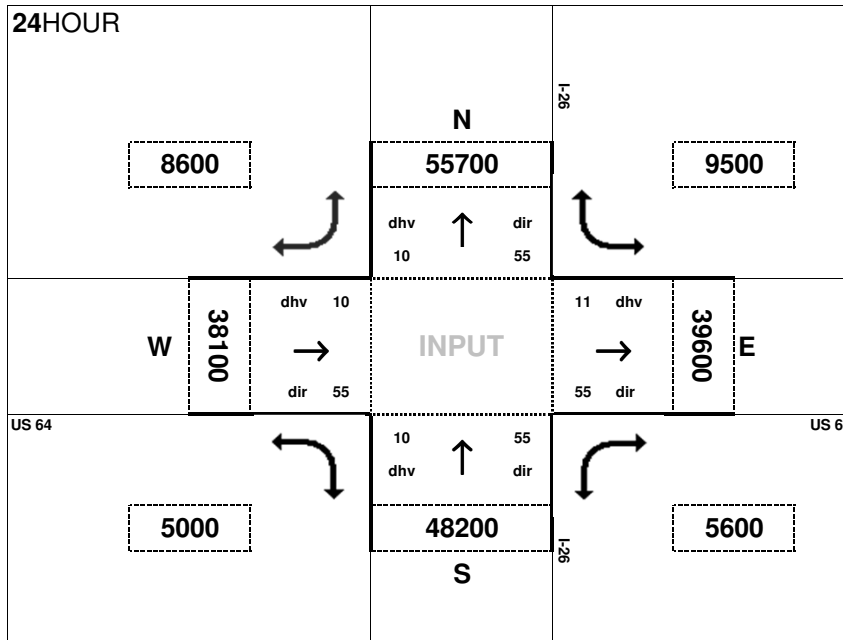

Peak Hour Volume Breakouts Report:
12. I-26 & US 64 System Interchange

Traffic Forecast Release Date:
February-12

Traffic Data Year:
2011 BY - Build 6 Ln

Project:
STIP I-4400/4700 - I-26 Widening

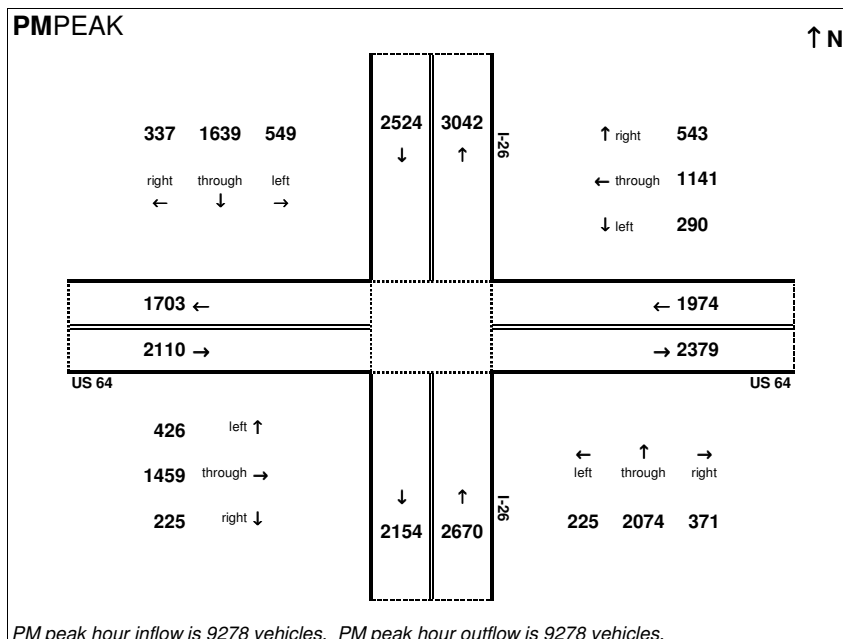
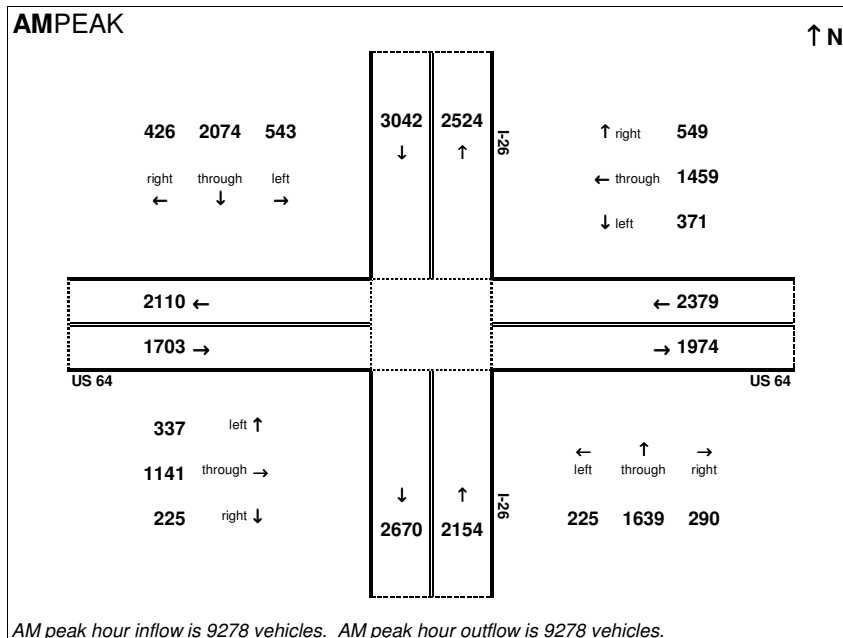

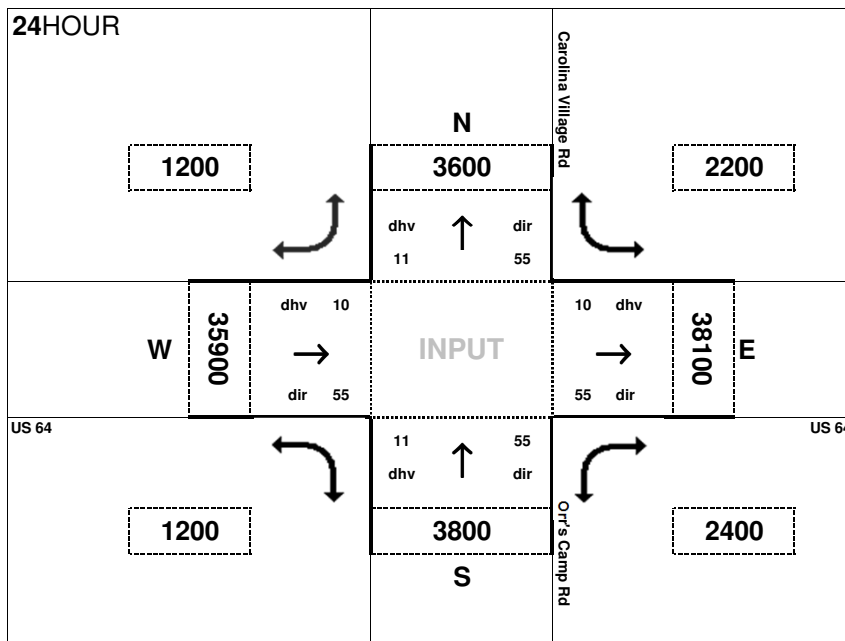

Peak Hour Volume Breakouts Report:

12a. US 64 & Carolina Village Rd / Orr's Camp Rd

Traffic Forecast Release Date:

February-12

Traffic Data Year:

2011 BY - 6 Lanes

Project:

STIP I-4400/4700 - I-26 Widening

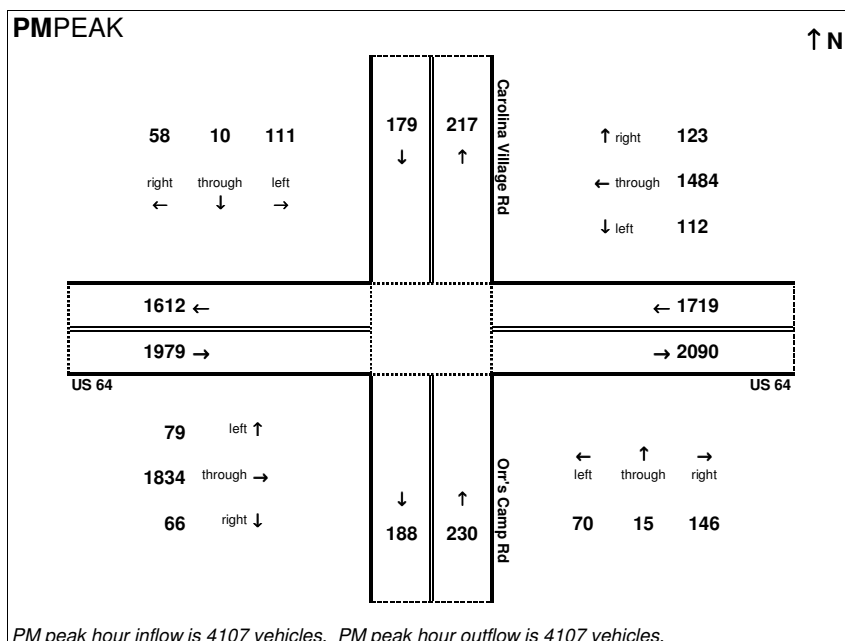
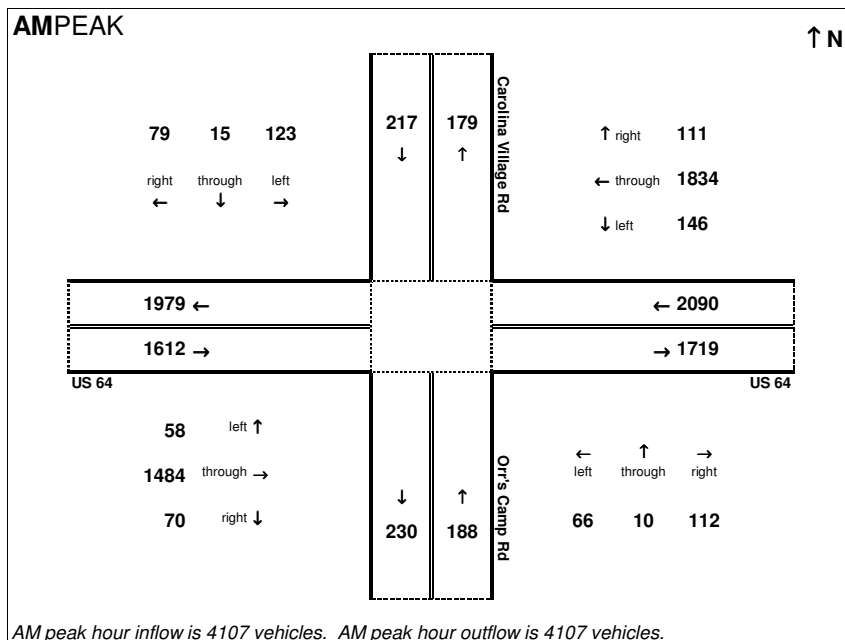

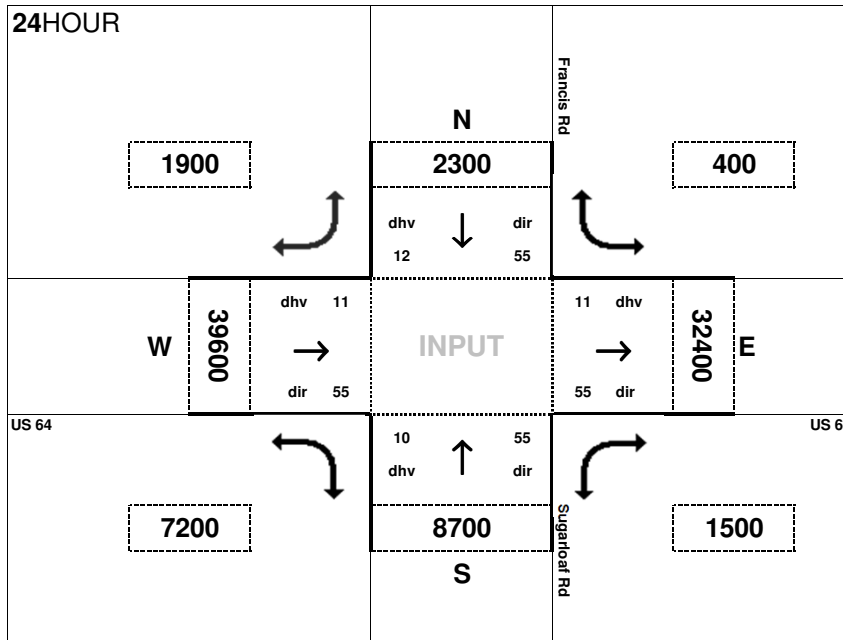

Peak Hour Volume Breakouts Report:
12b. US 64 & Francis Rd / Sugarloaf Rd

Traffic Forecast Release Date:
February-12

Traffic Data Year:
2011 BY - 6 Lanes

Project:
STIP I-4400/4700 - I-26 Widening

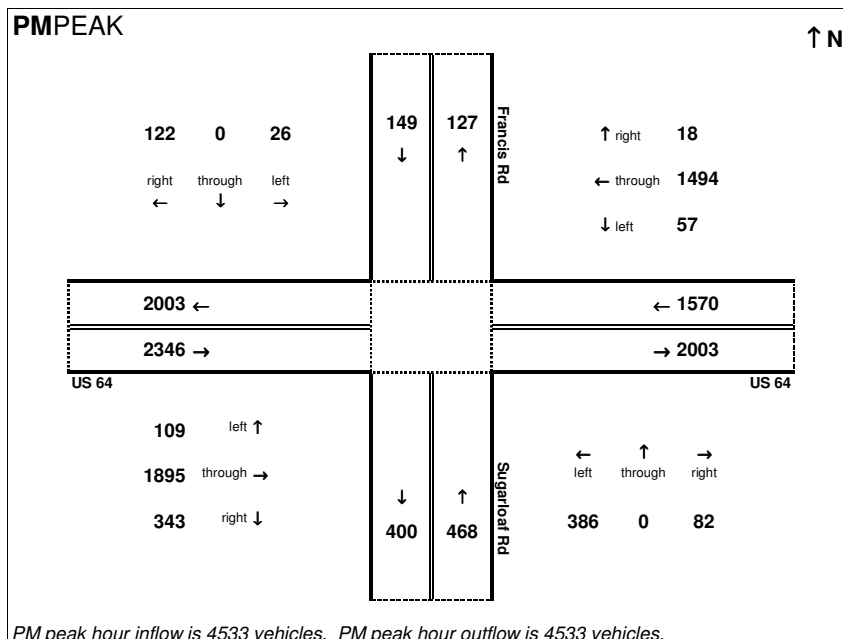
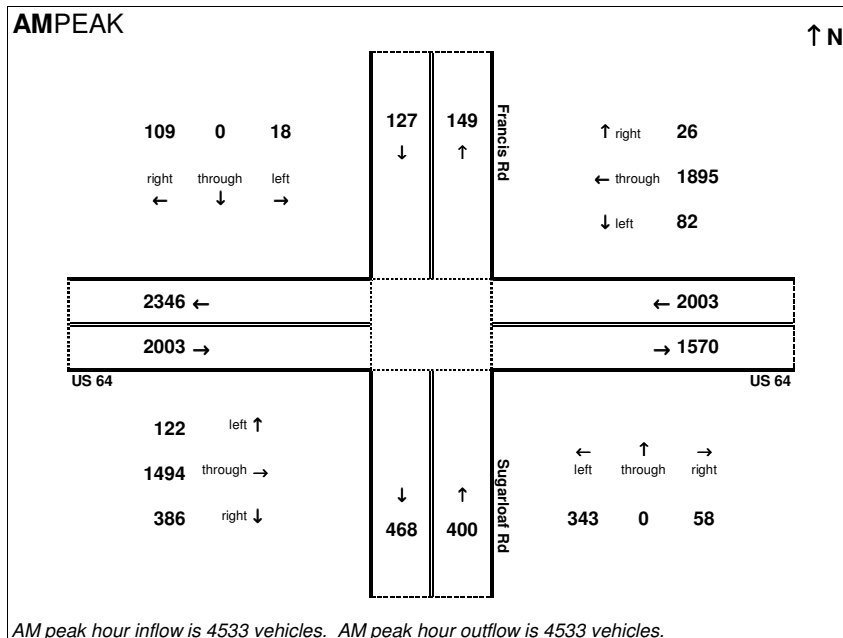

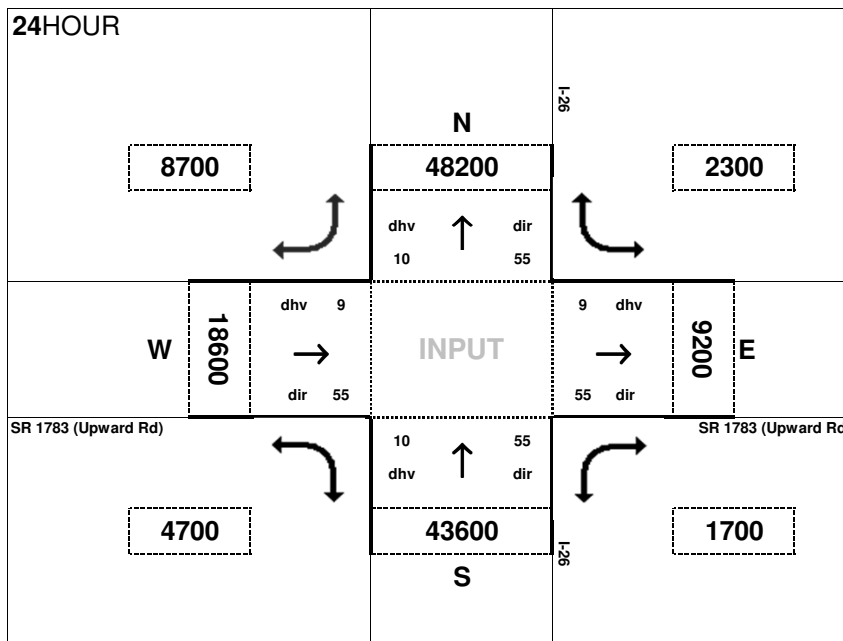

Peak Hour Volume Breakouts Report:
13. I-26 & Upward Road Interchange

Traffic Forecast Release Date:
February-12

Traffic Data Year:
2011 BY - Build 6 Ln

Project:
STIP I-4400/4700 - I-26 Widening

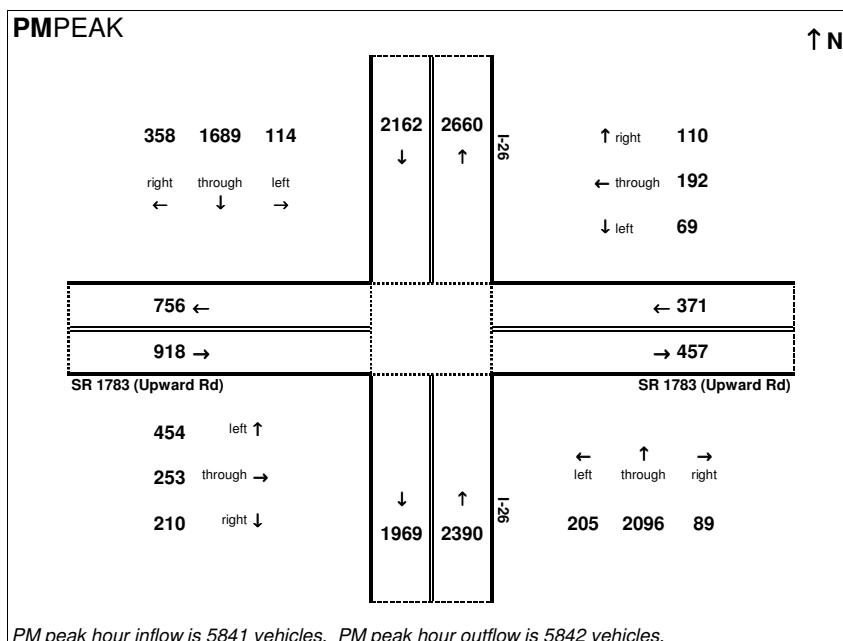
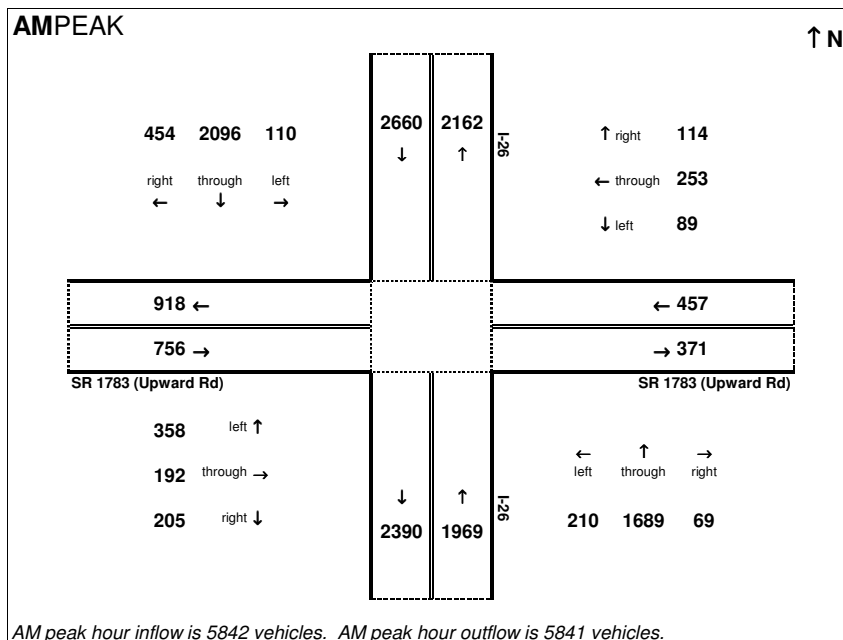

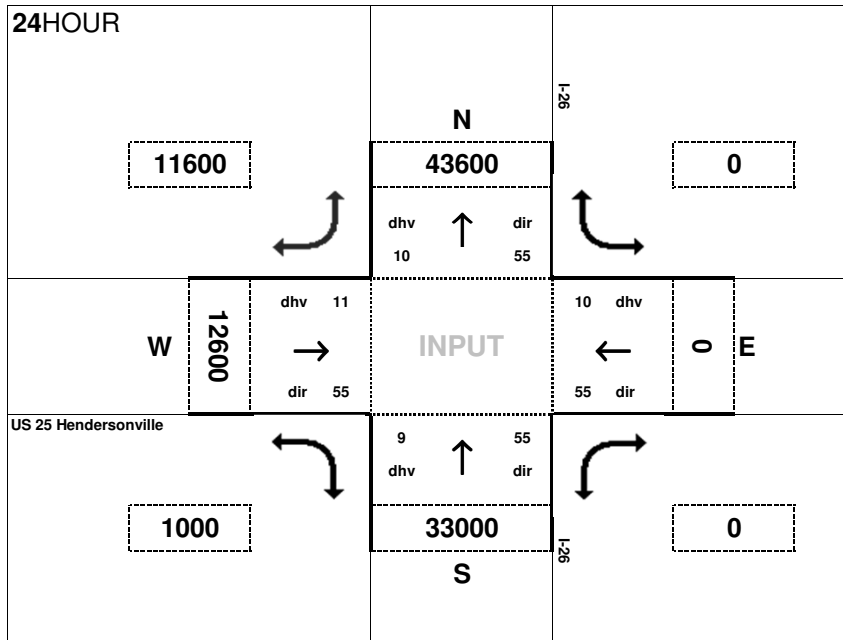

Peak Hour Volume Breakouts Report:
14. I-26 & US 25 Hendersonville Interchange

Traffic Forecast Release Date:
February-12

Traffic Data Year:
2011 BY - Build 6 Ln

Project:
STIP I-4400/4700 - I-26 Widening

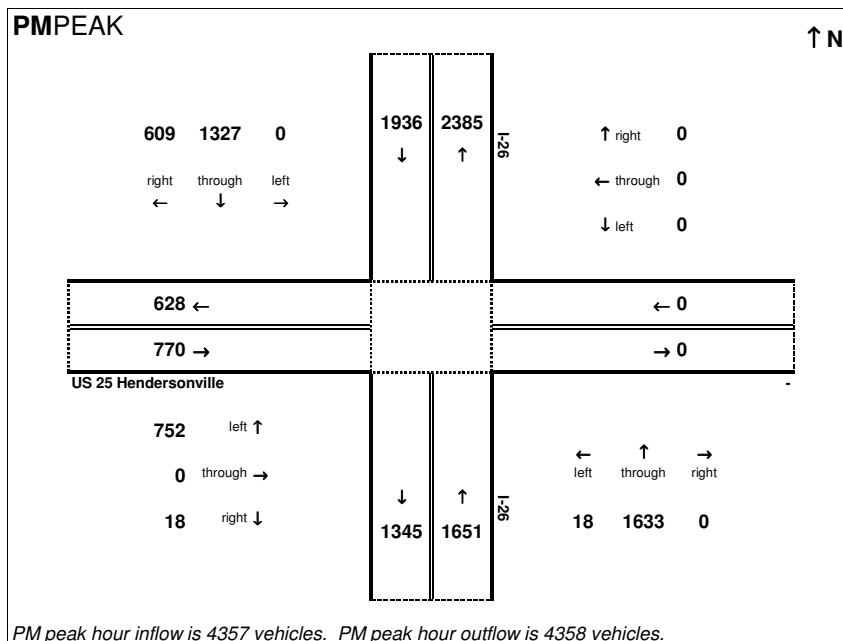
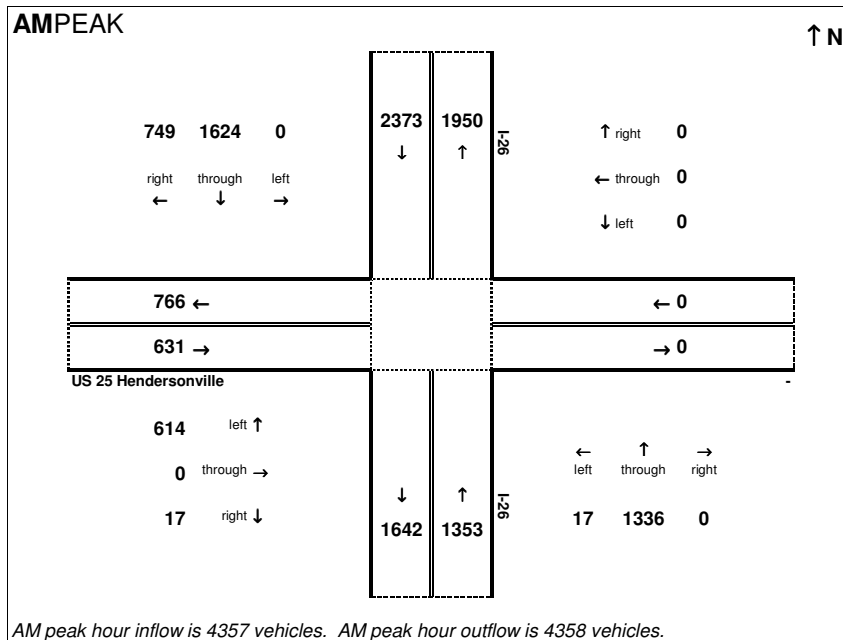

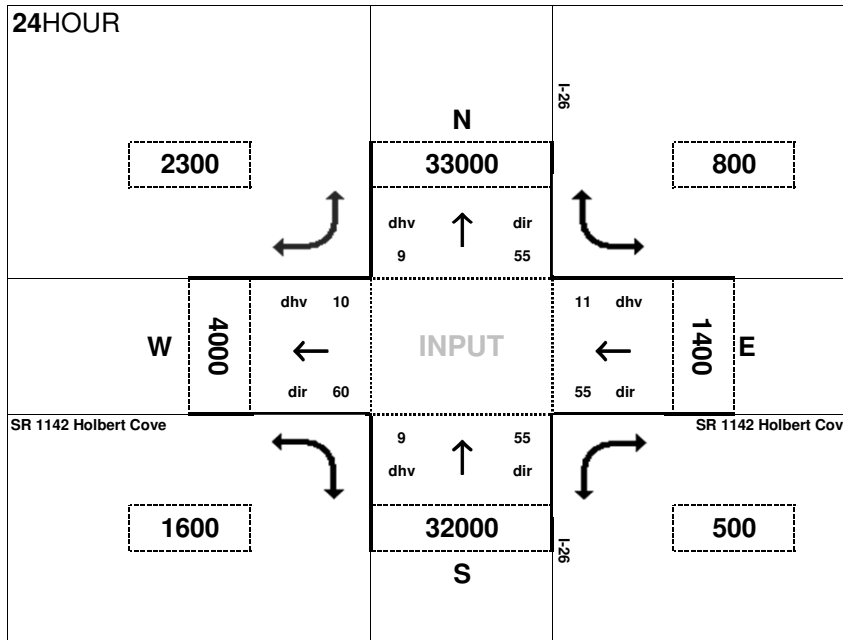

Peak Hour Volume Breakouts Report:
15. I-26 & Holbert Cove Rd Interchange

Traffic Forecast Release Date:
February-12

Traffic Data Year:
2011 BY - Build 6 Ln

Project:
STIP I-4400/4700 - I-26 Widening

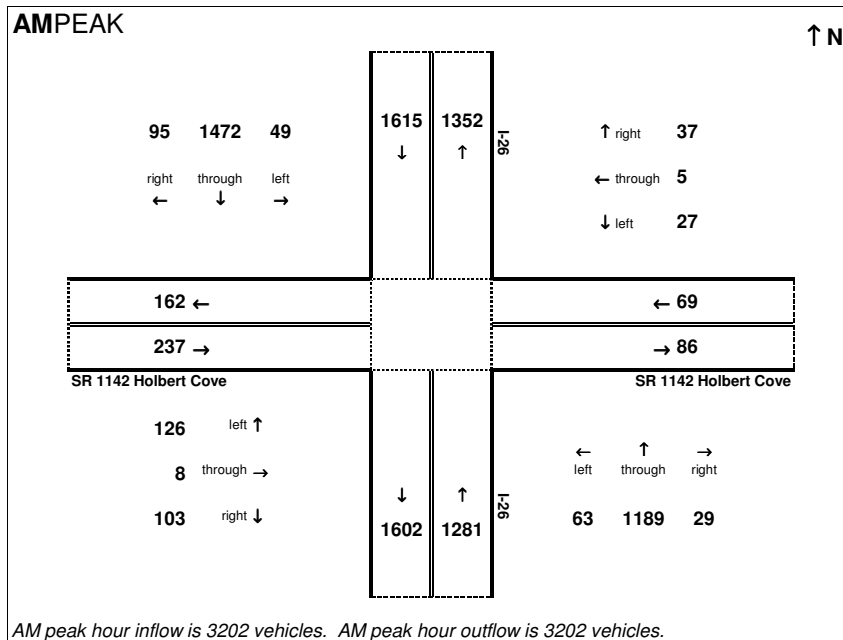

AM peak hour inflow is 3202 vehicles. AM peak hour outflow is 3202 vehicles.

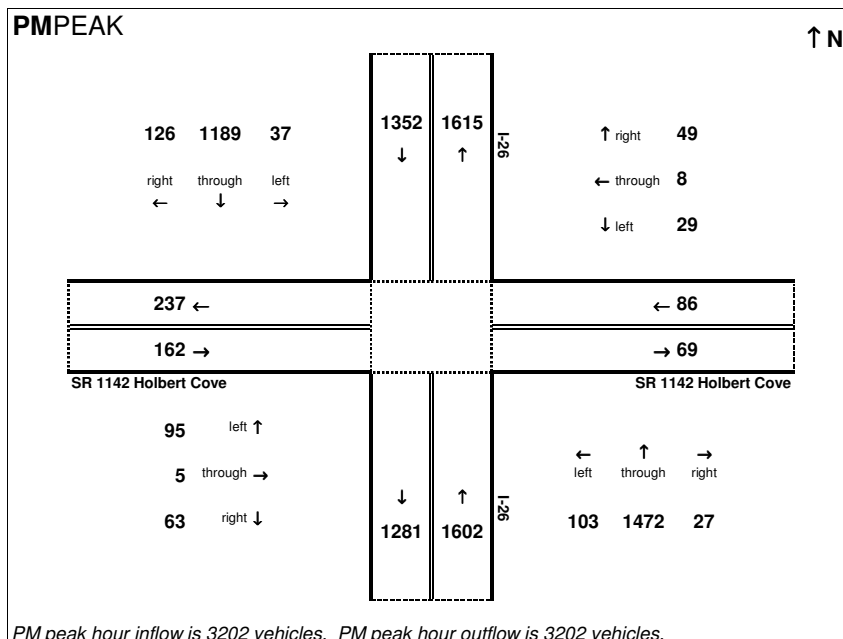

PM peak hour inflow is 3202 vehicles. PM peak hour outflow is 3202 vehicles.

2011 Build 8 Lane

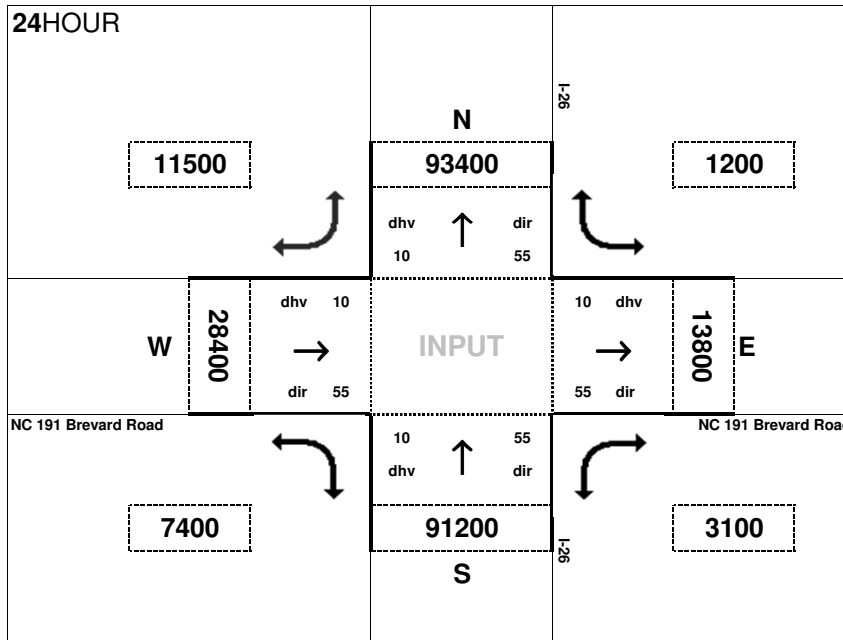

Peak Hour Volume Breakouts Report:
6. I-26 & NC 191 Interchange

Traffic Forecast Release Date:
February-12

Traffic Data Year:
2011 BY - Build 8 Ln

Project:
STIP I-4400/4700 - I-26 Widening

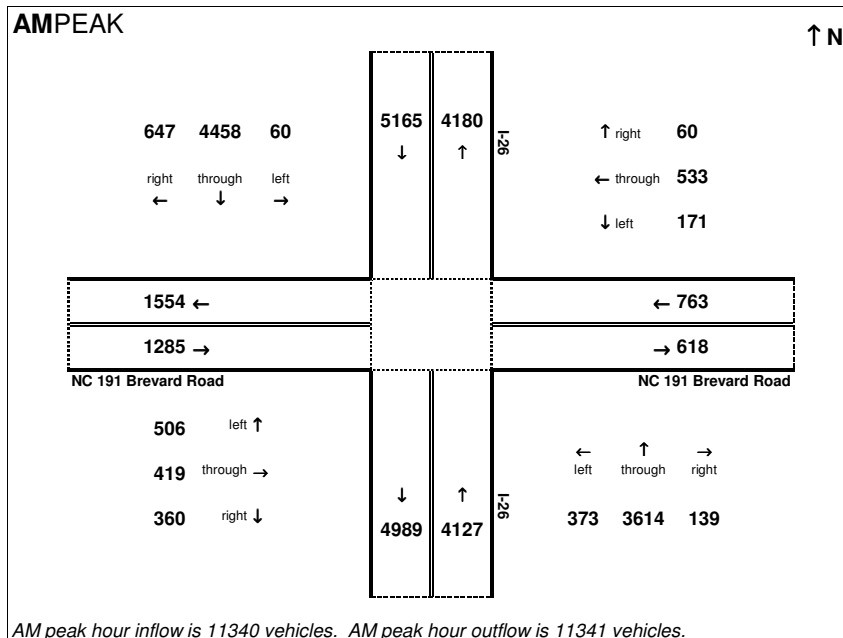

AM peak hour inflow is 11340 vehicles. AM peak hour outflow is 11341 vehicles.

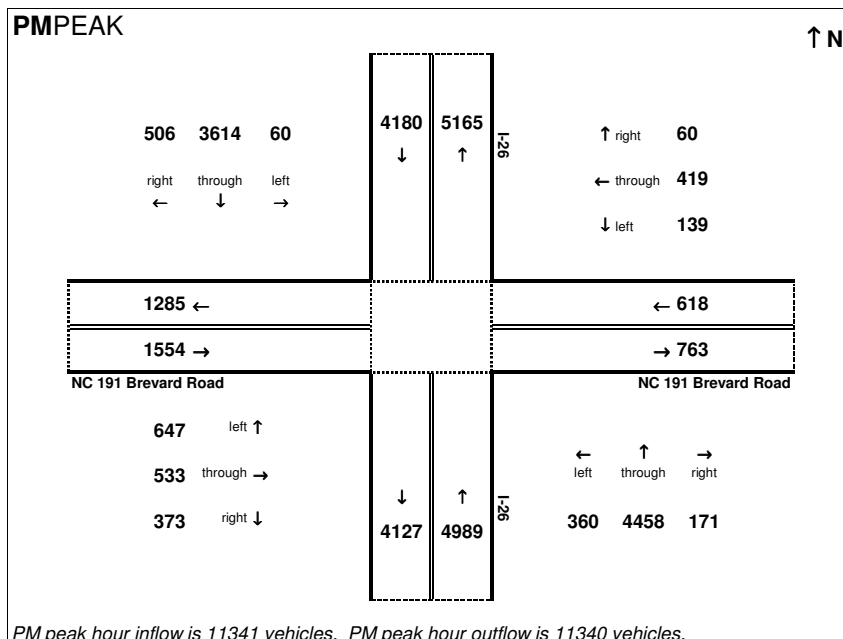

PM peak hour inflow is 11341 vehicles. PM peak hour outflow is 11340 vehicles.

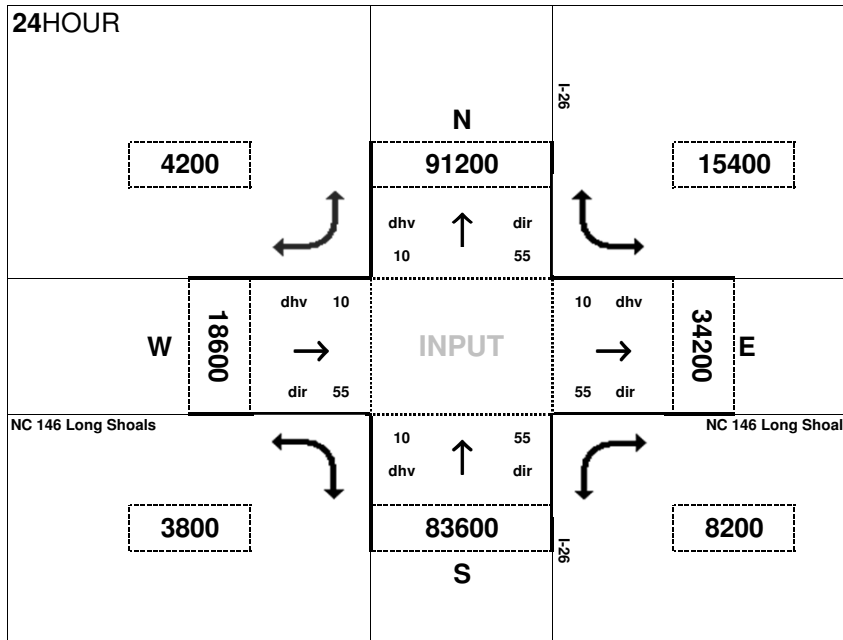

Peak Hour Volume Breakouts Report:
7. I-26 & NC 146 Interchange

Traffic Forecast Release Date:
February-12

Traffic Data Year:
2011 BY - Build 8 Ln

Project:
STIP I-4400/4700 - I-26 Widening

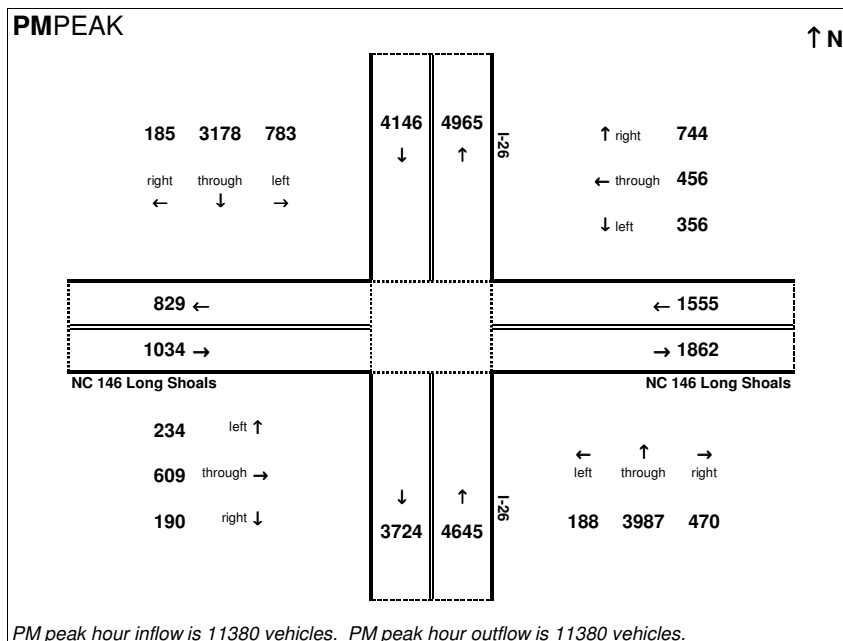
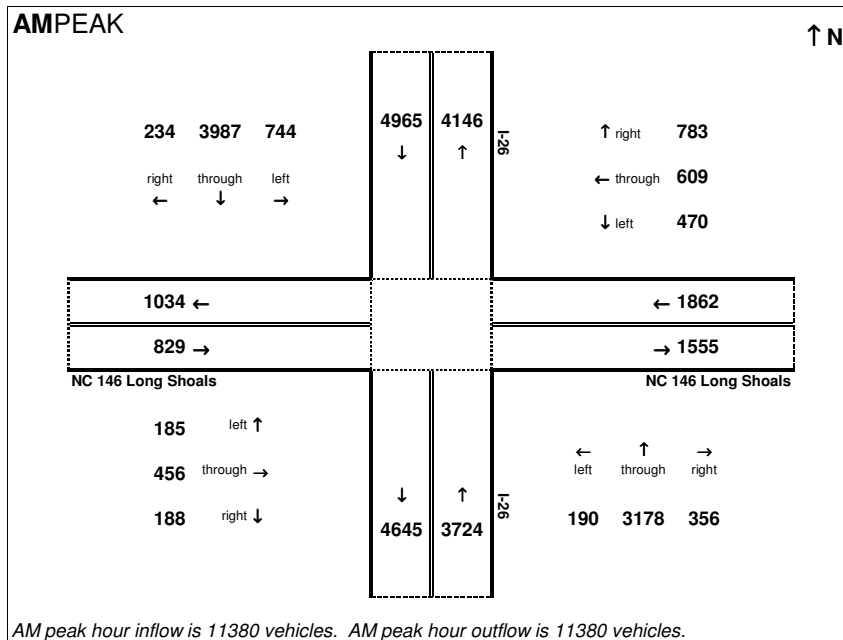

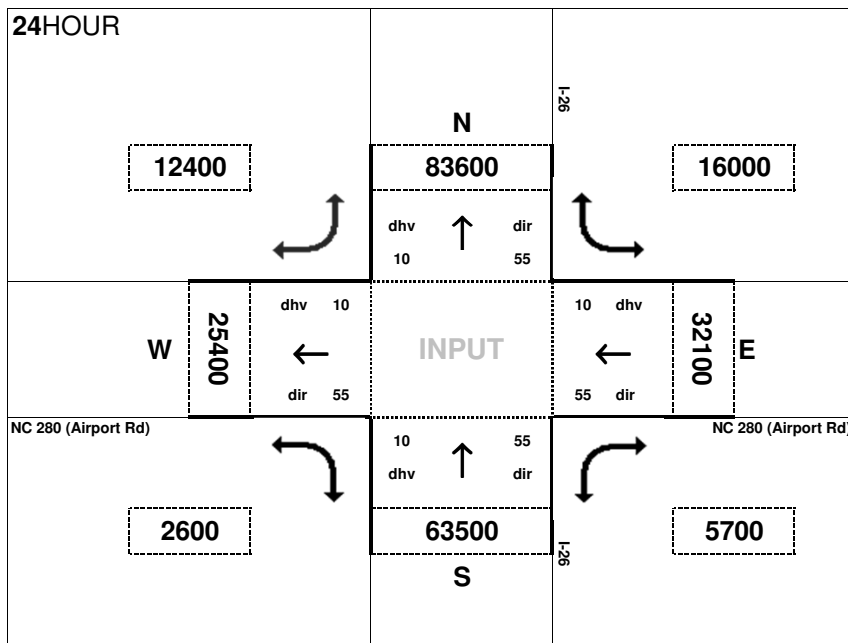

Peak Hour Volume Breakouts Report:
8. I-26 & NC 280 Interchange

Traffic Forecast Release Date:
February-12

Traffic Data Year:
2011 BY - Build 8 Ln

Project:
STIP I-4400/4700 - I-26 Widening

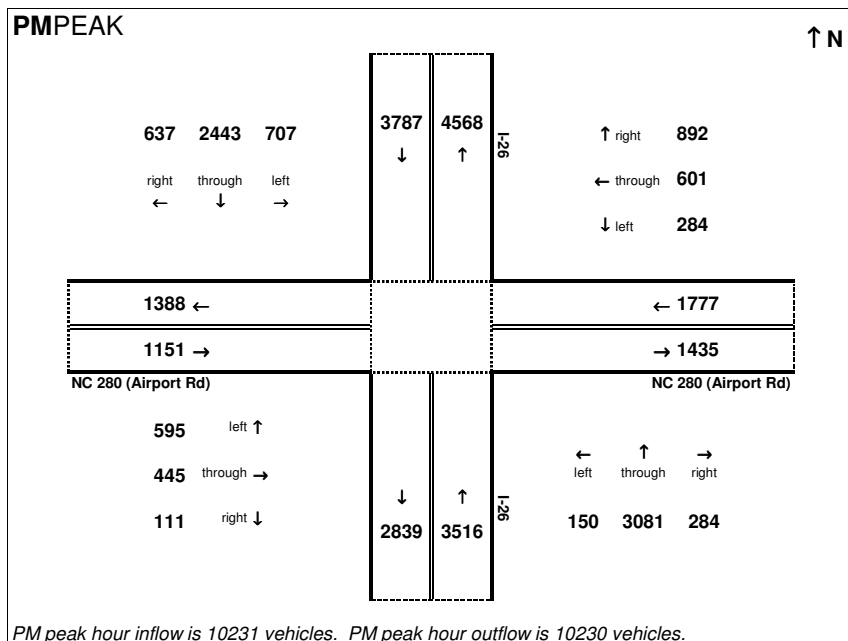
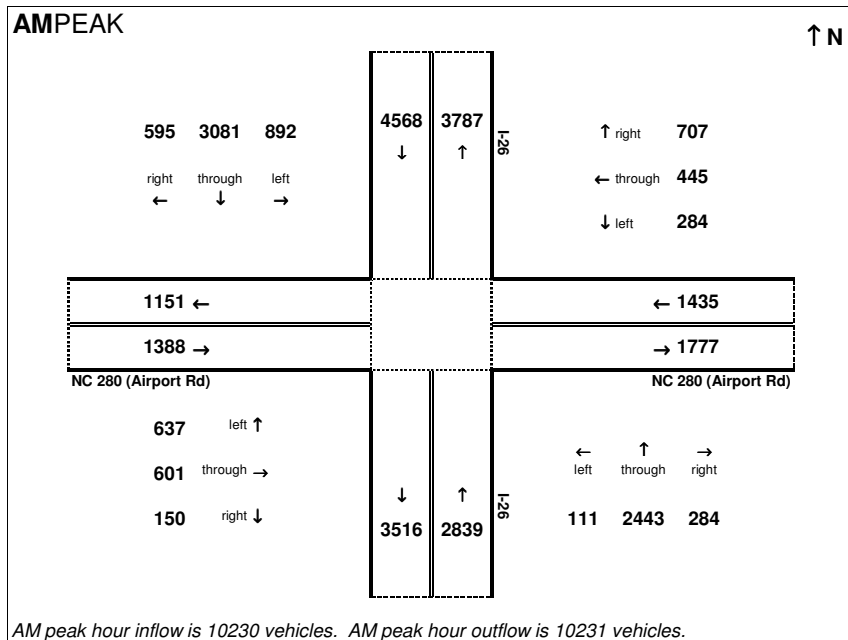

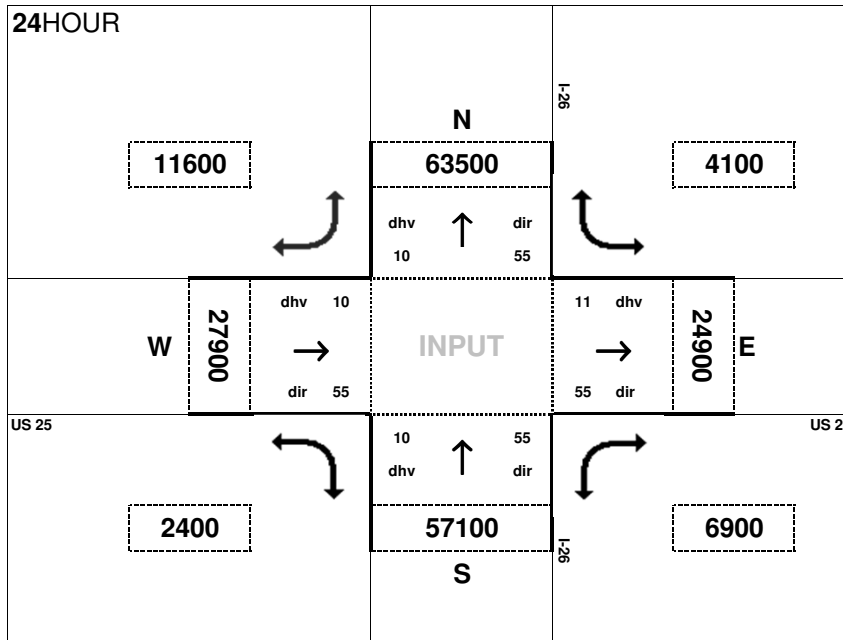

Peak Hour Volume Breakouts Report:
10. I-26 & US 25 Interchange

Traffic Forecast Release Date:
February-12

Traffic Data Year:
2011 BY - Build 8 Ln

Project:
STIP I-4400/4700 - I-26 Widening

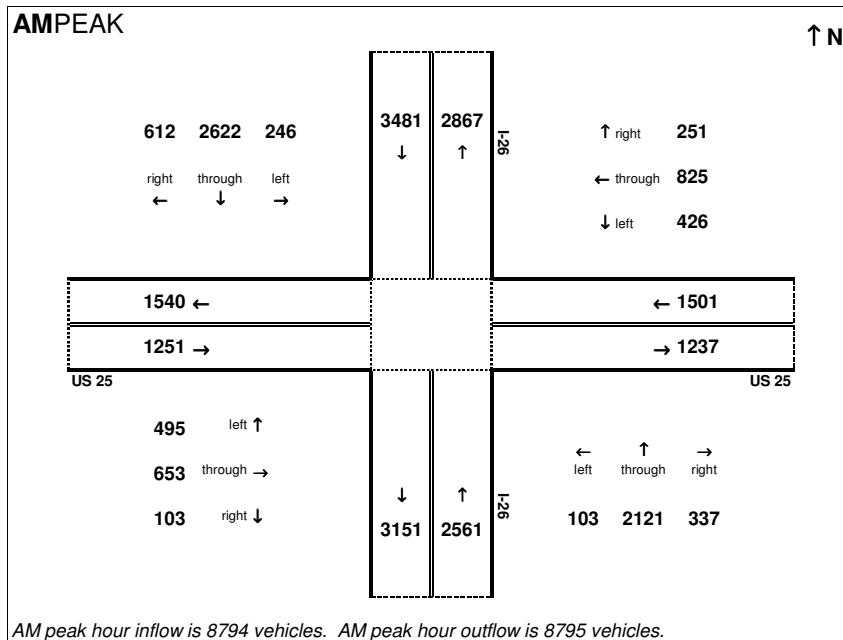

AM peak hour inflow is 8794 vehicles. AM peak hour outflow is 8795 vehicles.

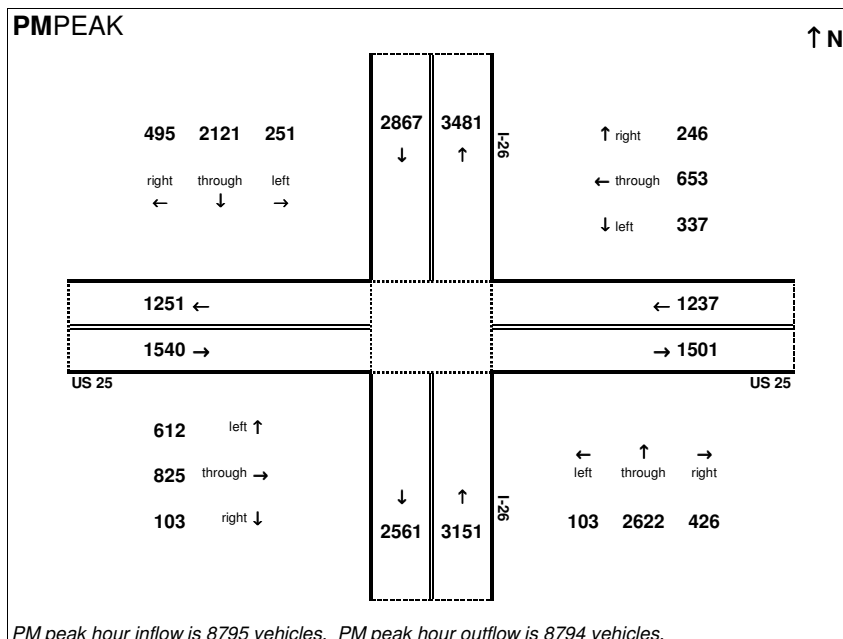

PM peak hour inflow is 8795 vehicles. PM peak hour outflow is 8794 vehicles.

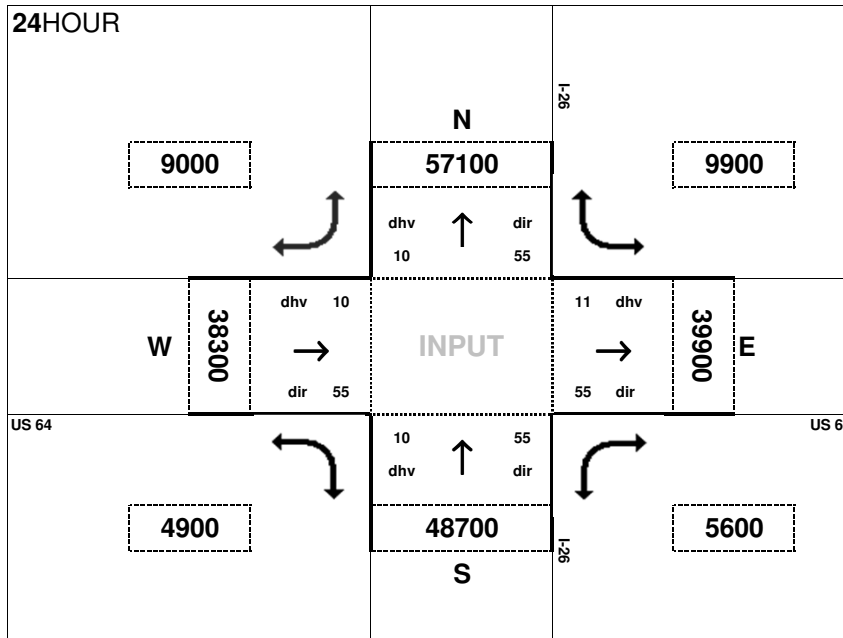

Peak Hour Volume Breakouts Report:
12. I-26 & US 64 System Interchange

Traffic Forecast Release Date:
February-12

Traffic Data Year:
2011 BY - Build 8 Ln

Project:
STIP I-4400/4700 - I-26 Widening

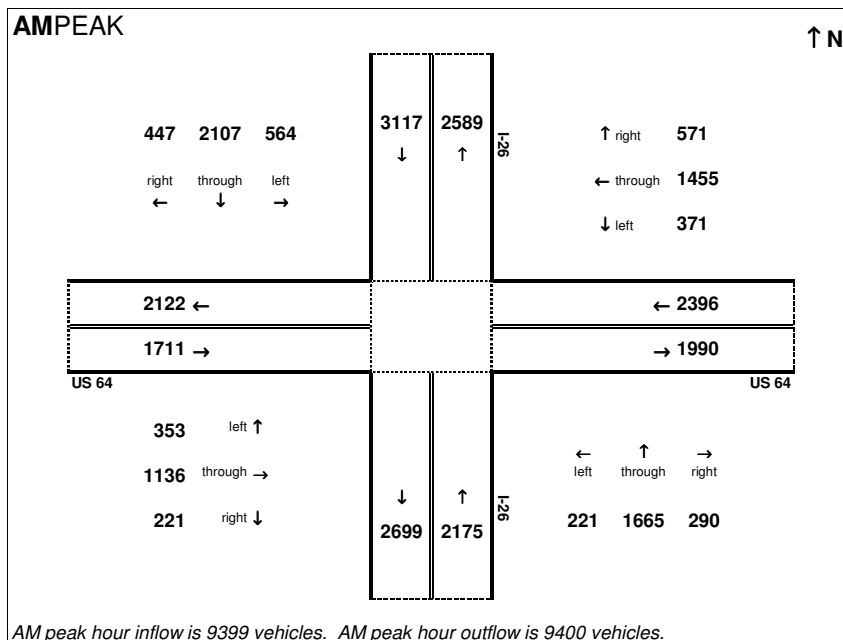

AM peak hour inflow is 9399 vehicles. AM peak hour outflow is 9400 vehicles.

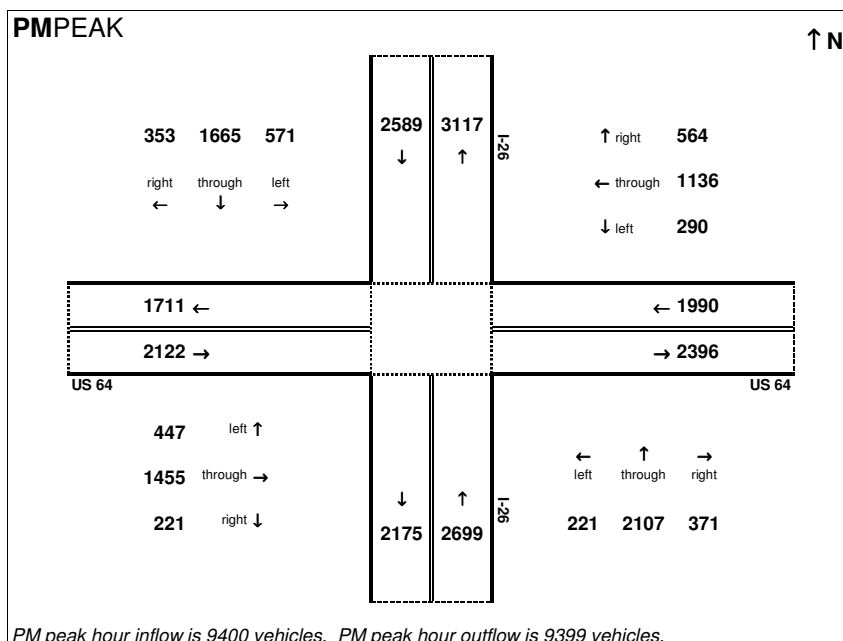

PM peak hour inflow is 9400 vehicles. PM peak hour outflow is 9399 vehicles.

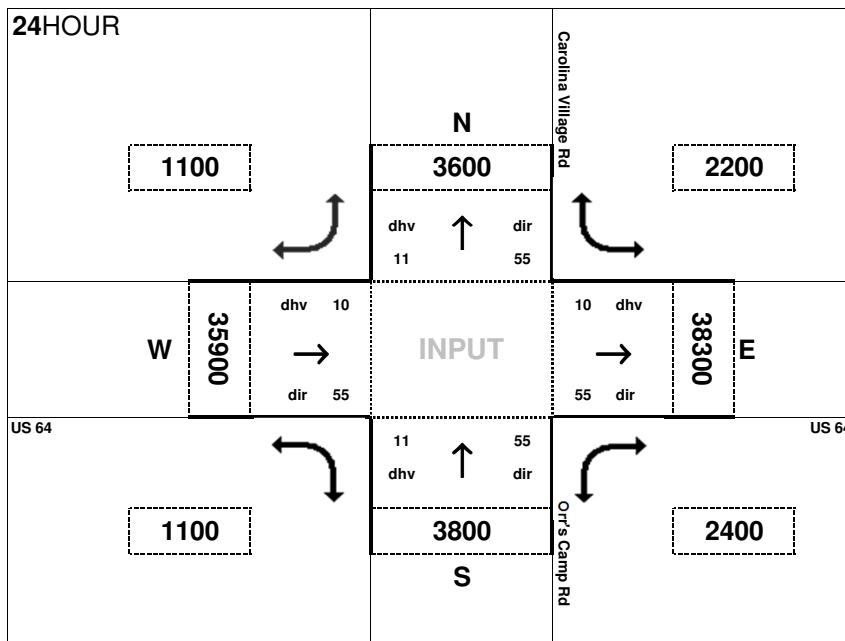

Peak Hour Volume Breakouts Report:

12a. US 64 & Carolina Village Rd / Orr's Camp Rd

Traffic Forecast Release Date:

February-12

Traffic Data Year:

2011 BY - 8 Lanes

Project:

STIP I-4400/4700 - I-26 Widening

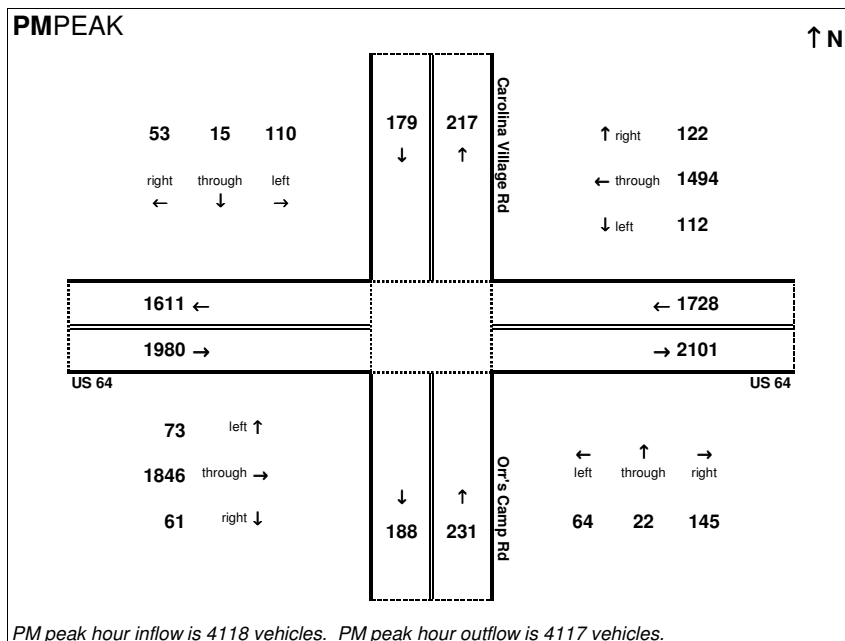
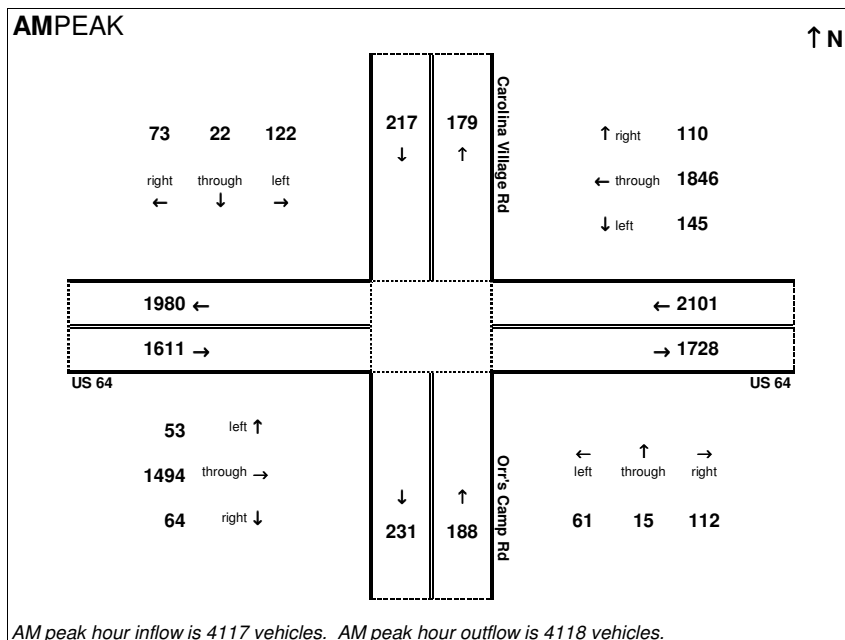

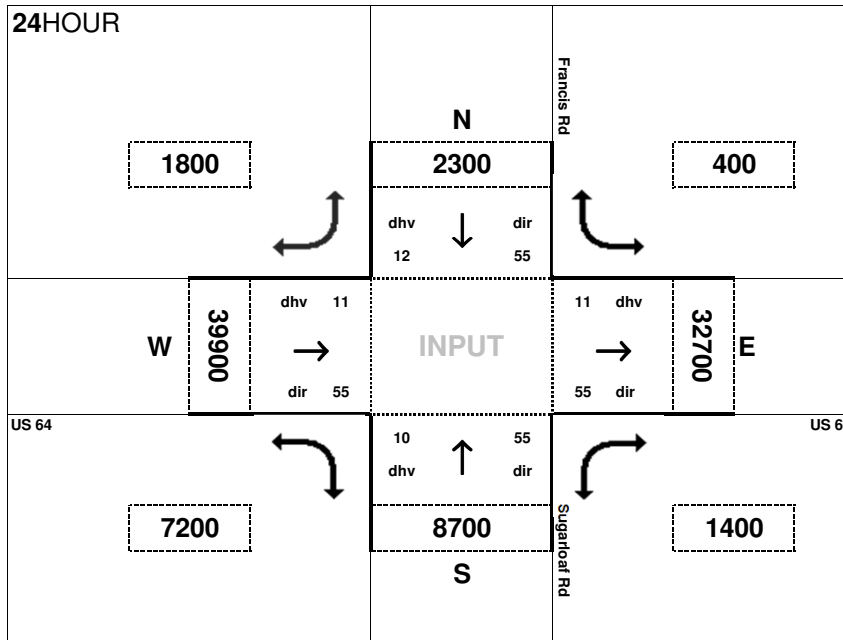

Peak Hour Volume Breakouts Report:
12b. US 64 & Francis Rd / Sugarloaf Rd

Traffic Forecast Release Date:
February-12

Traffic Data Year:
2011 BY - 8 Lanes

Project:
STIP I-4400/4700 - I-26 Widening

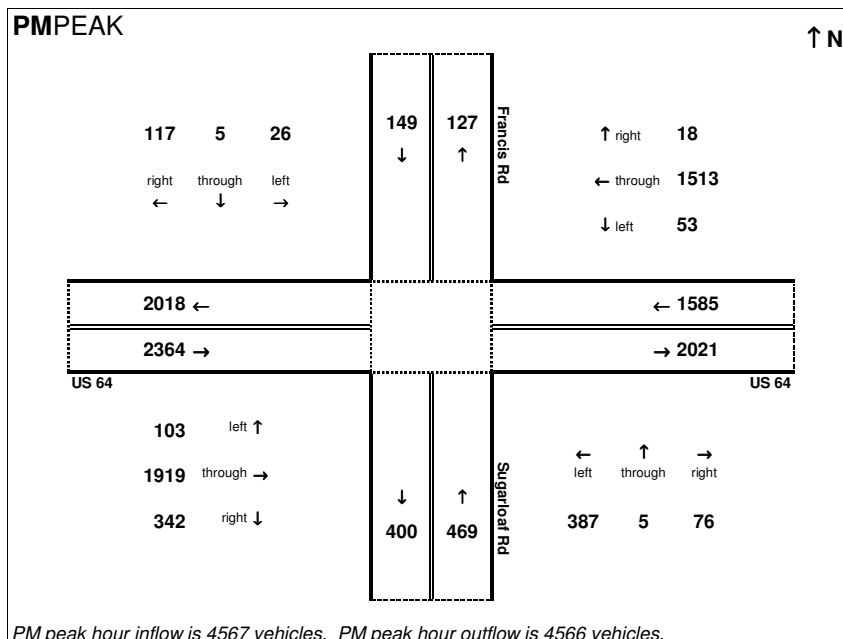
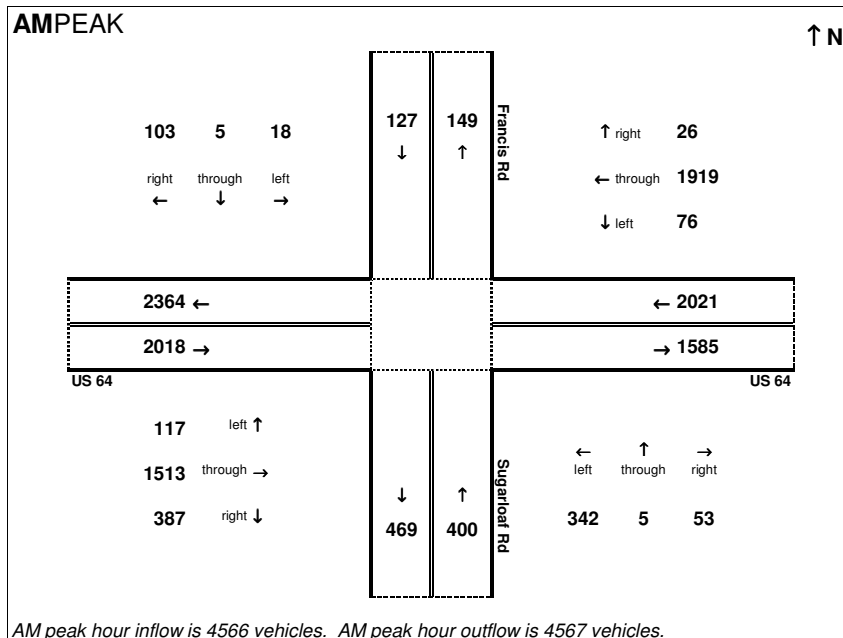

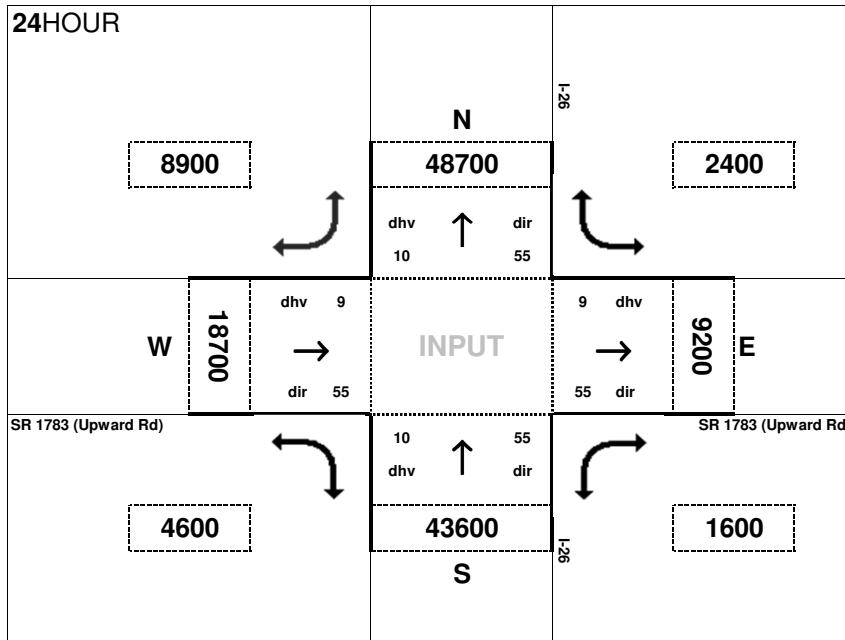

Peak Hour Volume Breakouts Report:
13. I-26 & Upward Road Interchange

Traffic Forecast Release Date:
February-12

Traffic Data Year:
2011 BY - Build 8 Ln

Project:
STIP I-4400/4700 - I-26 Widening

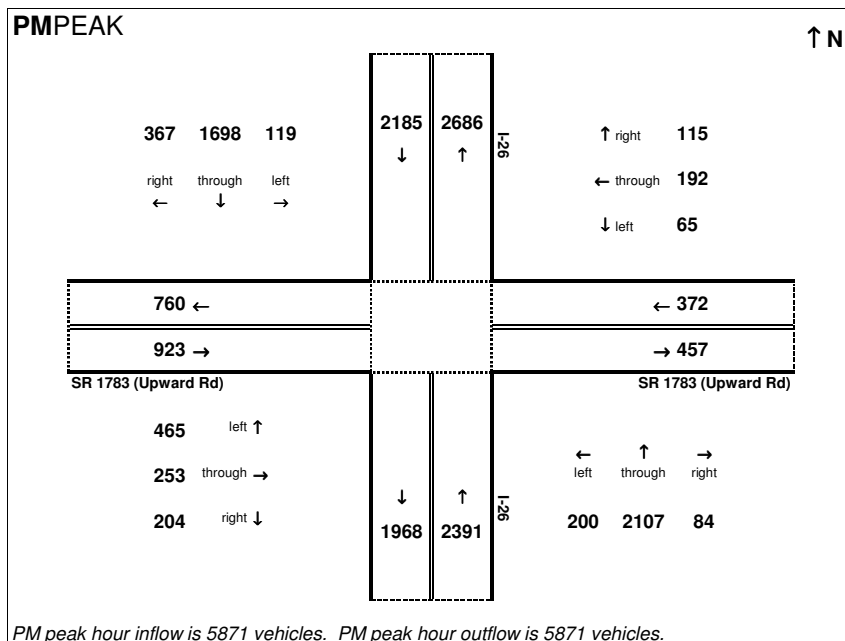
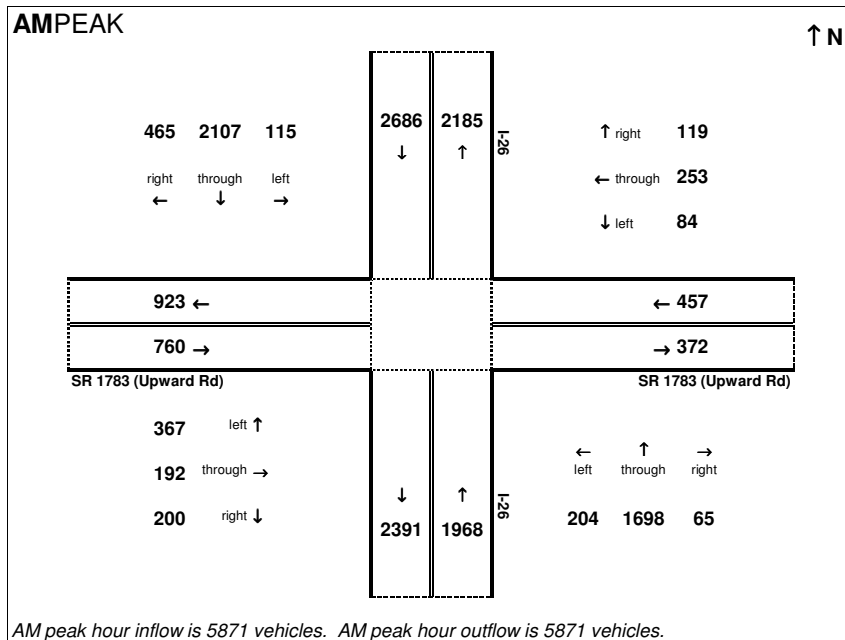

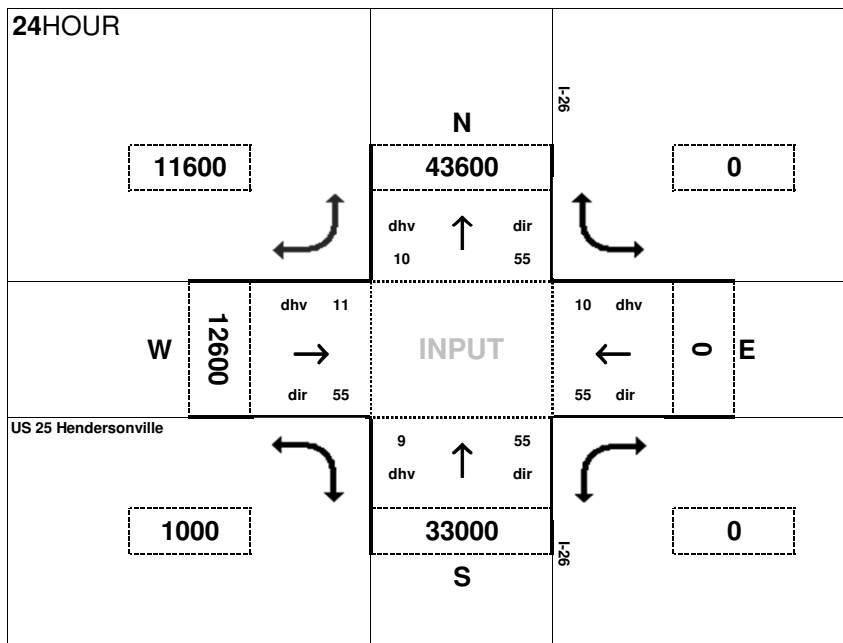

Peak Hour Volume Breakouts Report:
14. I-26 & US 25 Hendersonville Interchange

Traffic Forecast Release Date:
February-12

Traffic Data Year:
2011 BY - Build 8 Ln

Project:
STIP I-4400/4700 - I-26 Widening

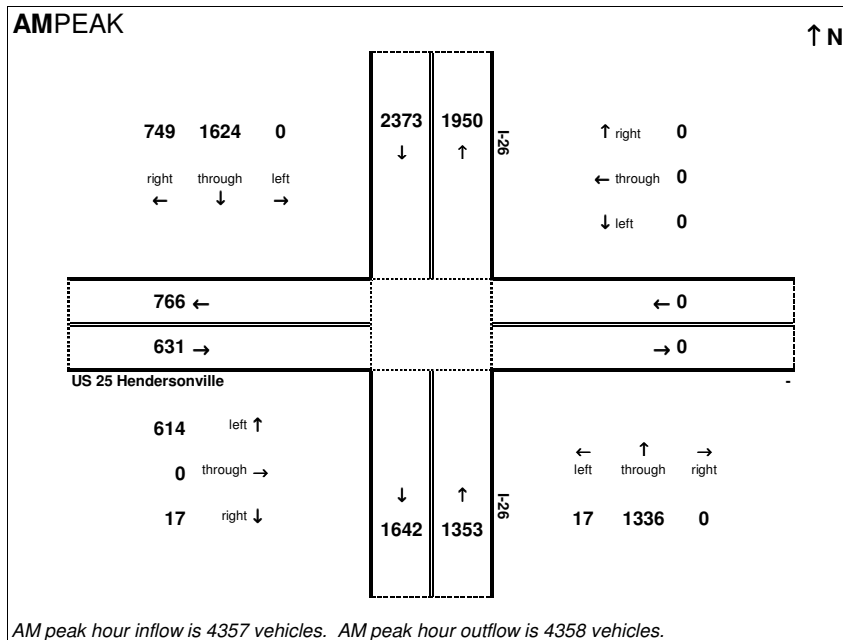

AM peak hour inflow is 4357 vehicles. AM peak hour outflow is 4358 vehicles.

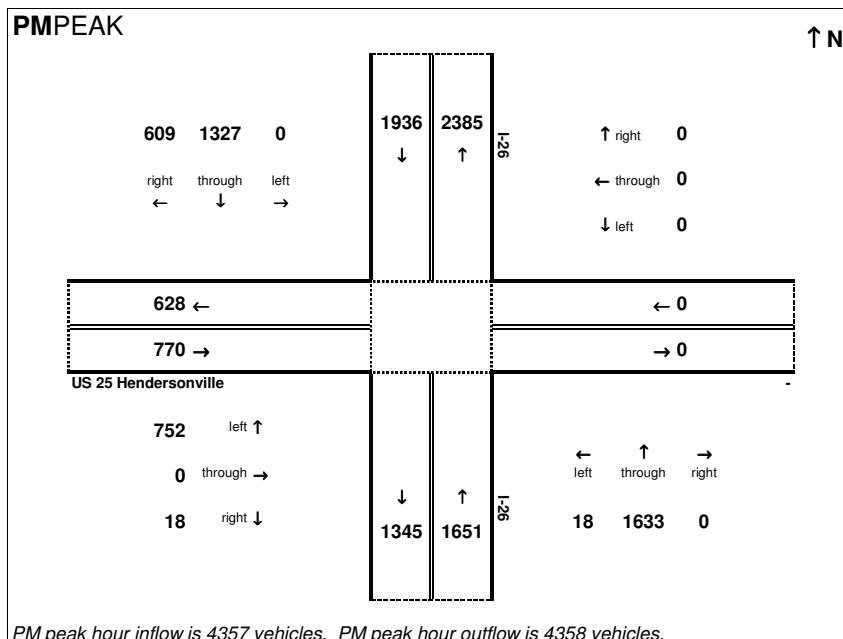

PM peak hour inflow is 4372 vehicles. PM peak hour outflow is 4373 vehicles.

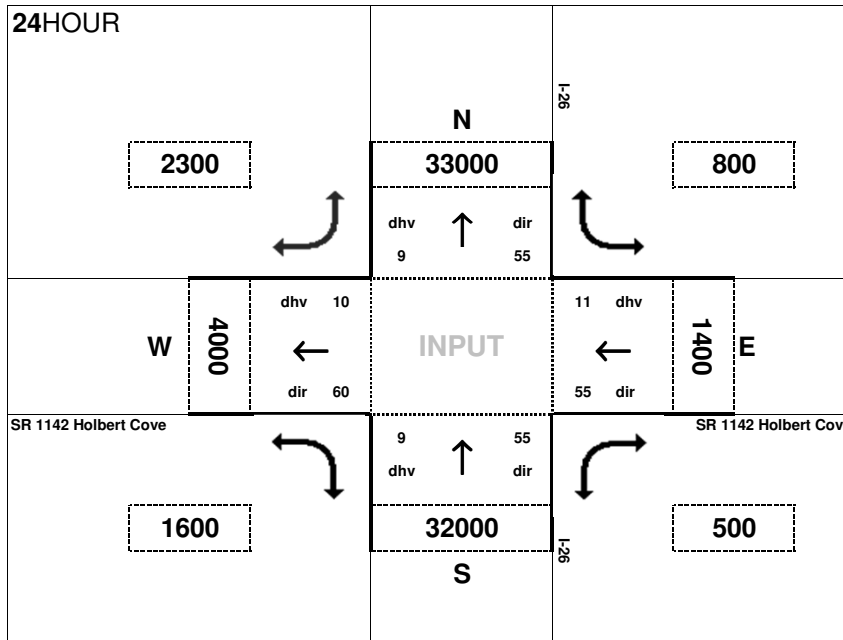

Peak Hour Volume Breakouts Report:
15. I-26 & Holbert Cove Rd Interchange

Traffic Forecast Release Date:
February-12

Traffic Data Year:
2011 BY - Build 8 Ln

Project:
STIP I-4400/4700 - I-26 Widening

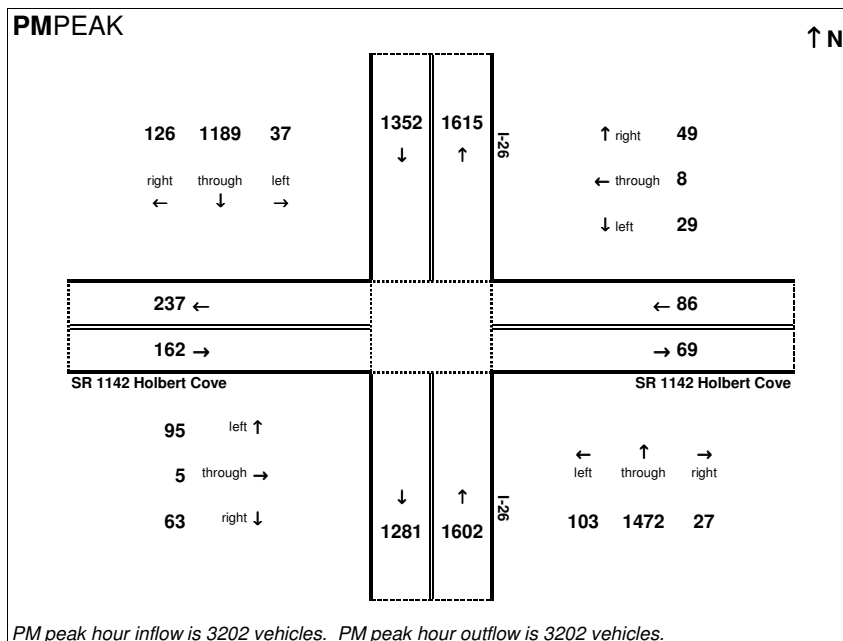
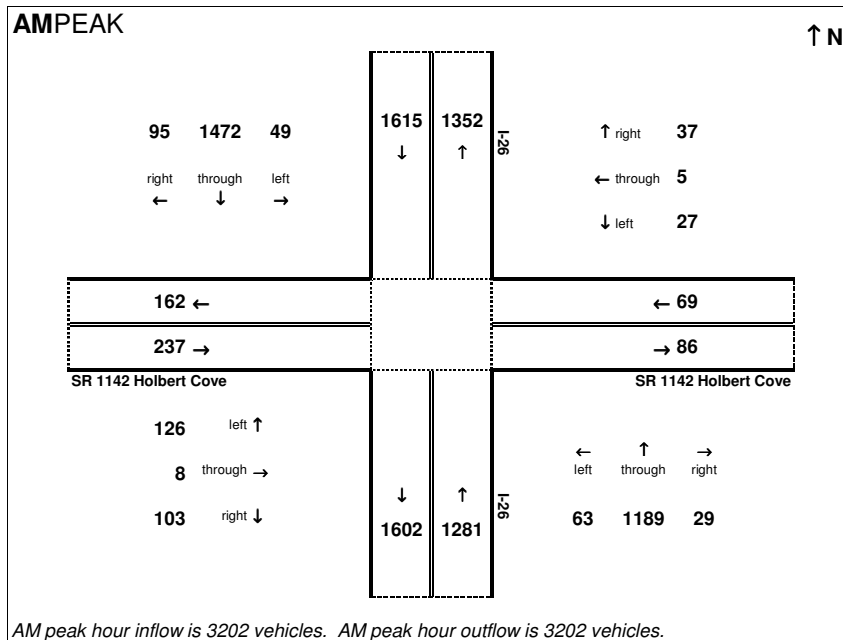

2040 No-Build

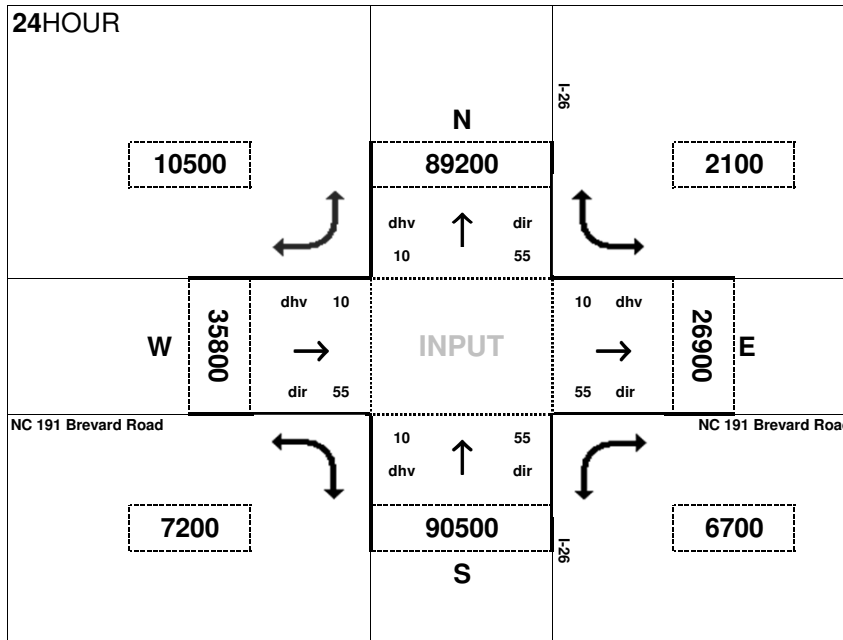

Peak Hour Volume Breakouts Report:
6. I-26 & NC 191 Interchange

Traffic Forecast Release Date:
February-12

Traffic Data Year:
2040 DY - No-Build

Project:
STIP I-4400/4700 - I-26 Widening

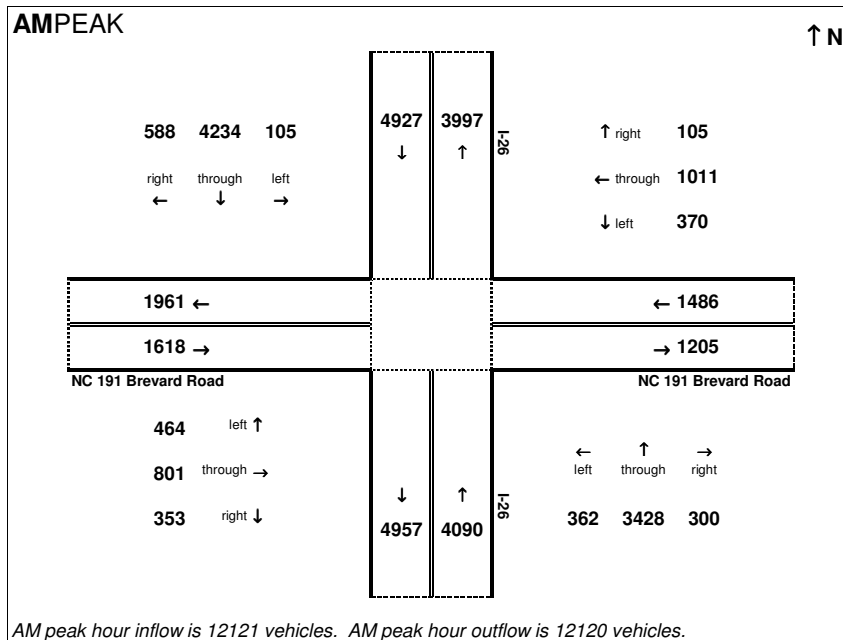

AM peak hour inflow is 12121 vehicles. AM peak hour outflow is 12120 vehicles.

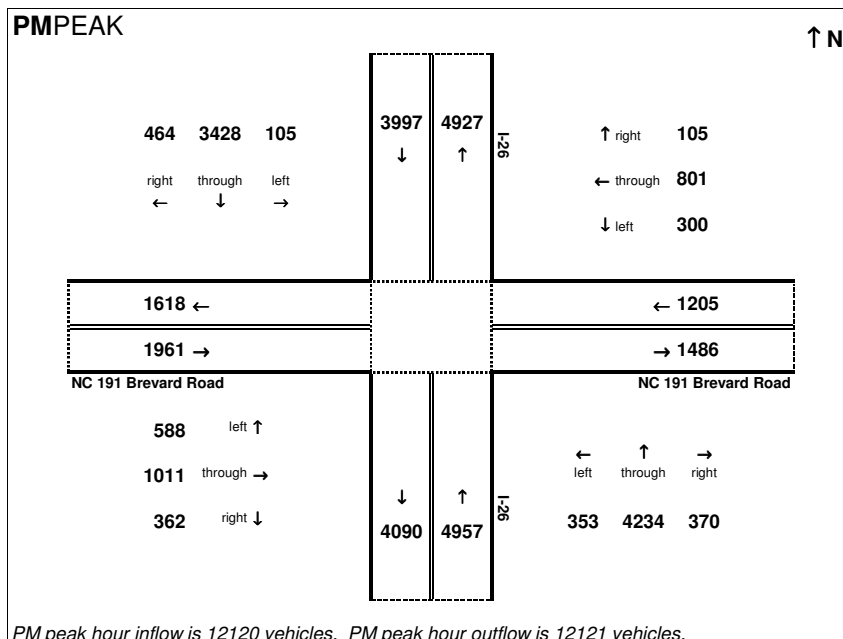

PM peak hour inflow is 12120 vehicles. PM peak hour outflow is 12121 vehicles.

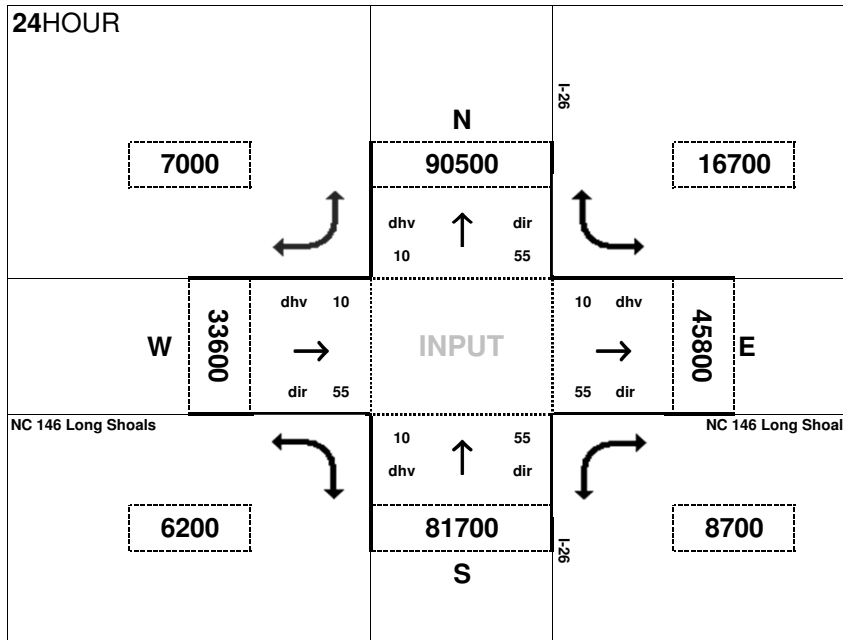

Peak Hour Volume Breakouts Report:
7. I-26 & NC 146 Interchange

Traffic Forecast Release Date:
February-12

Traffic Data Year:
2040 DY - No-Build

Project:
STIP I-4400/4700 - I-26 Widening

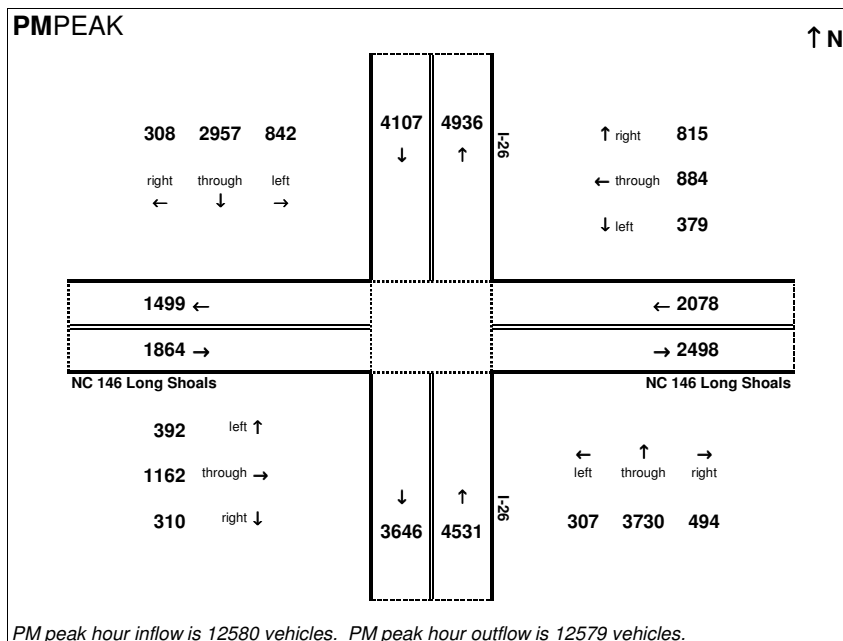
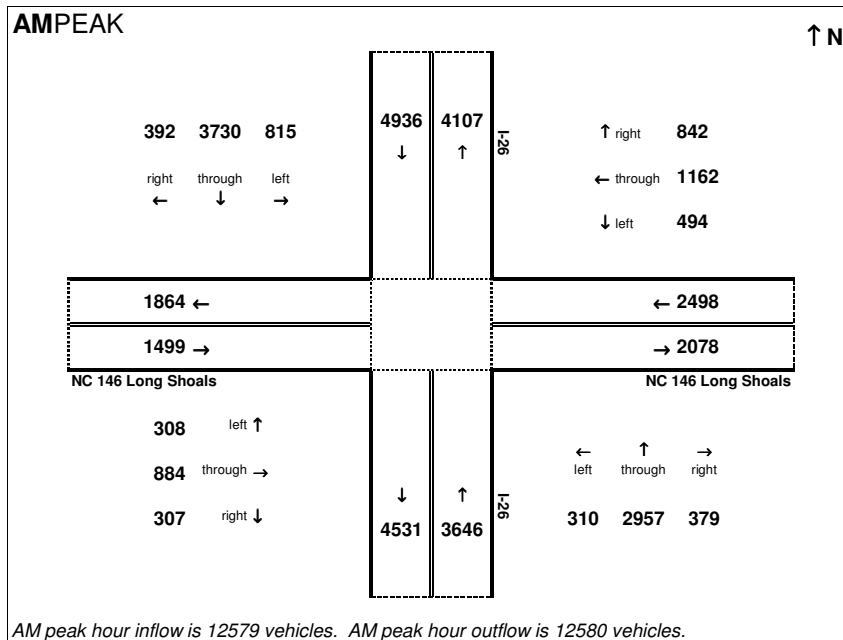

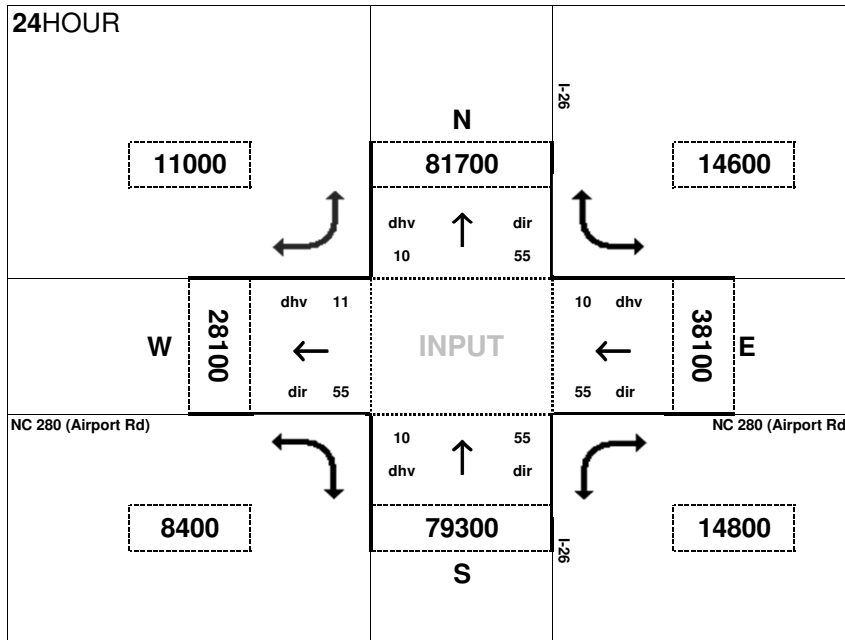

Peak Hour Volume Breakouts Report:
8. I-26 & NC 280 Interchange

Traffic Forecast Release Date:
February-12

Traffic Data Year:
2040 DY - No-Build

Project:
STIP I-4400/4700 - I-26 Widening

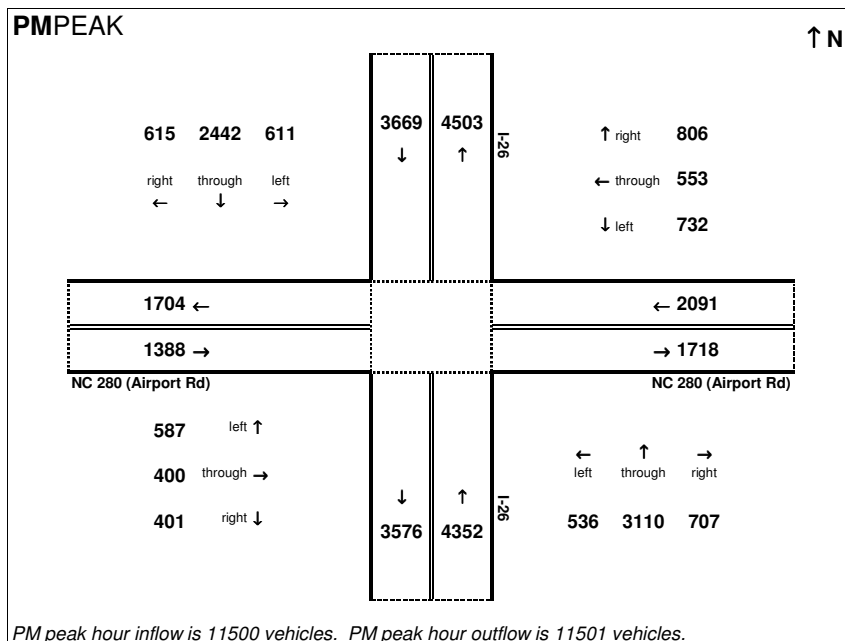
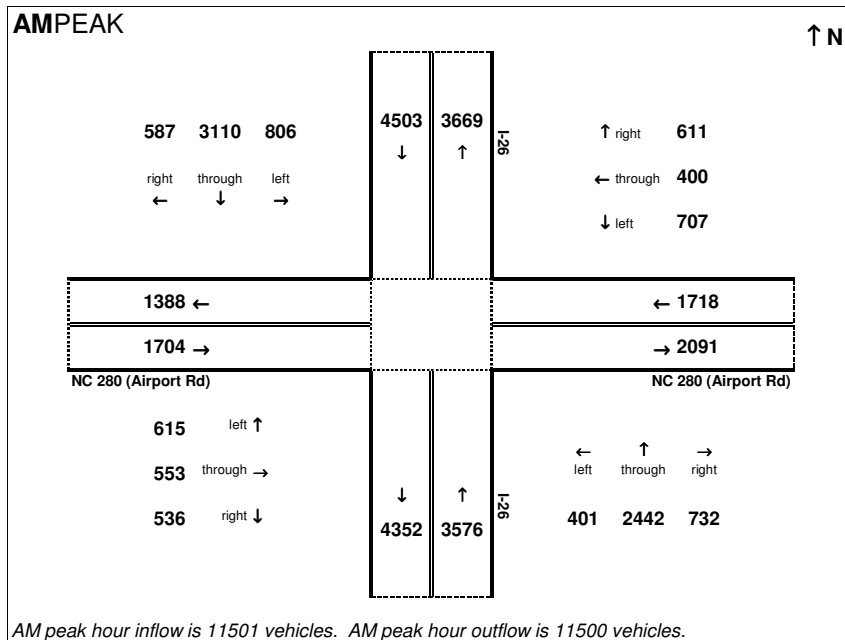

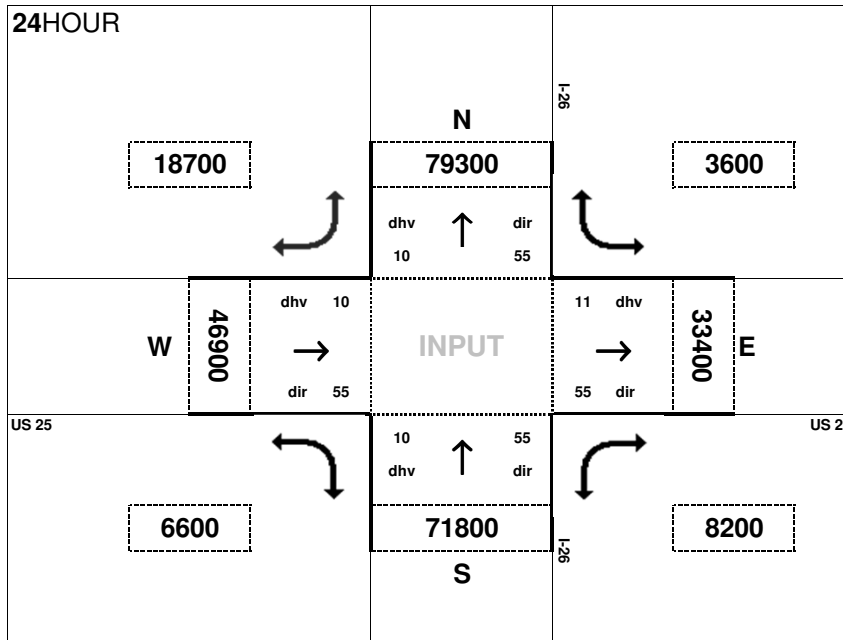

Peak Hour Volume Breakouts Report:
10. I-26 & US 25 Interchange

Traffic Forecast Release Date:
February-12

Traffic Data Year:
2040 DY - No-Build

Project:
STIP I-4400/4700 - I-26 Widening

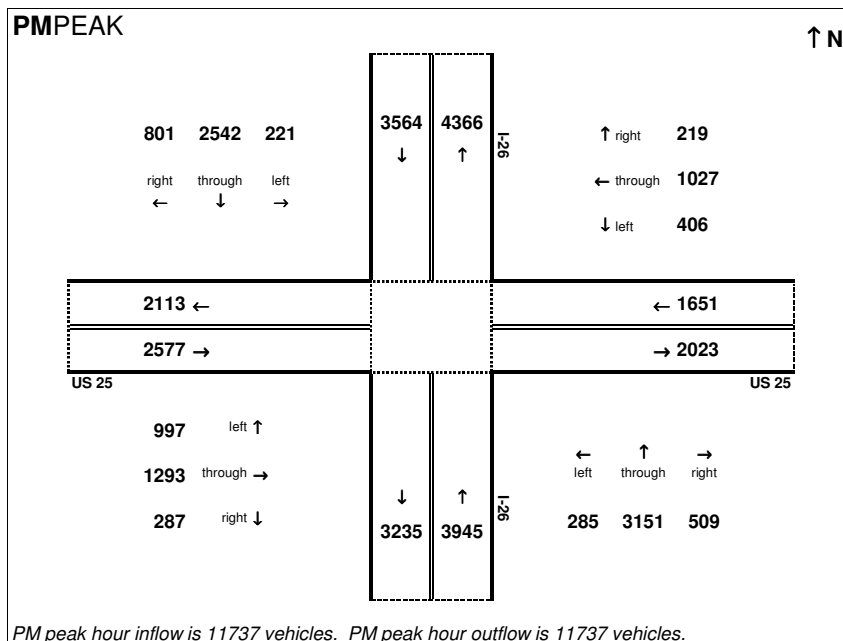
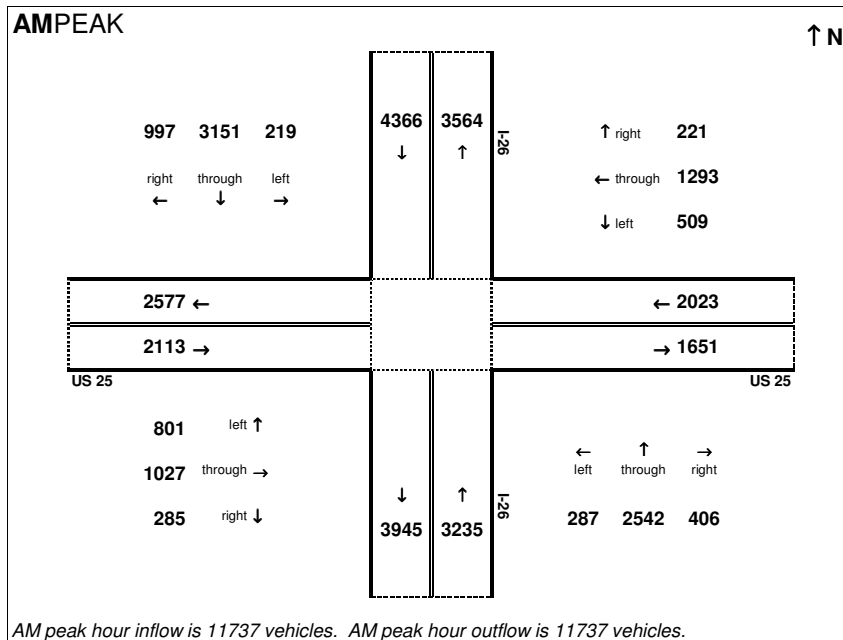

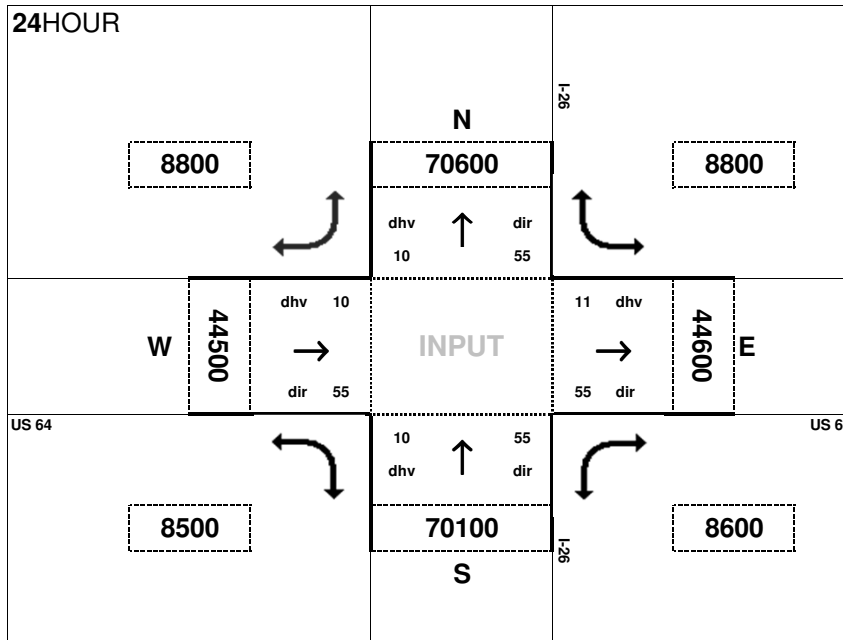

Peak Hour Volume Breakouts Report:
12. I-26 & US 64 System Interchange

Traffic Forecast Release Date:
February-12

Traffic Data Year:
2040 DY - No-Build

Project:
STIP I-4400/4700 - I-26 Widening

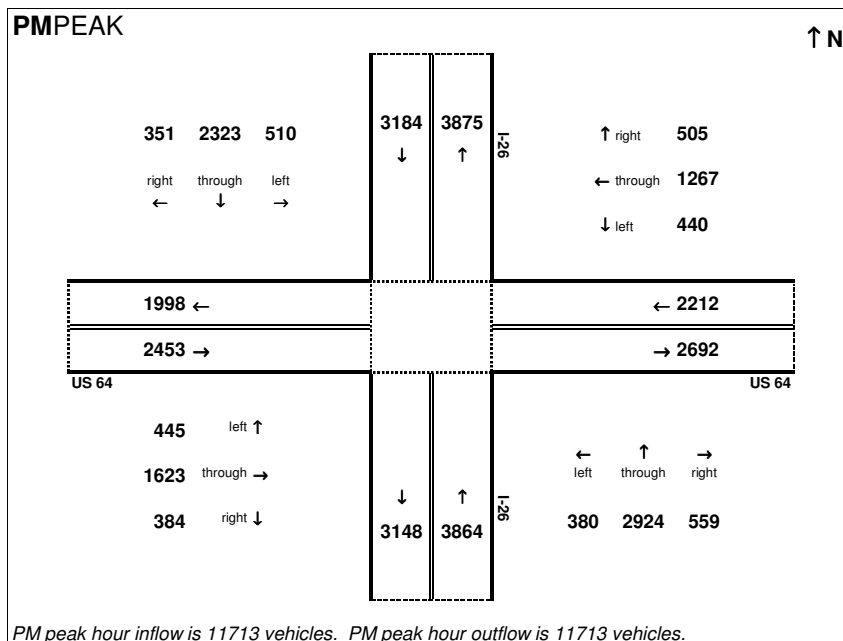
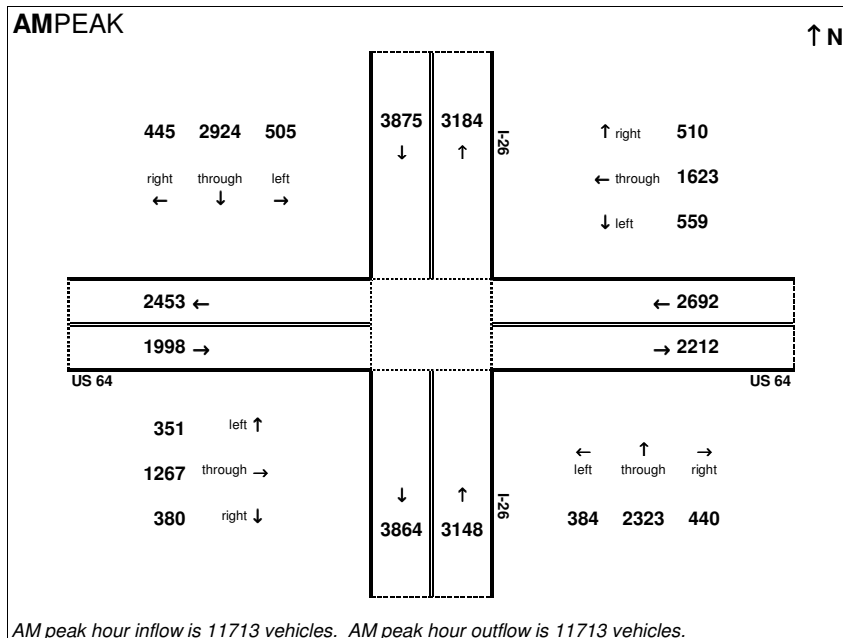

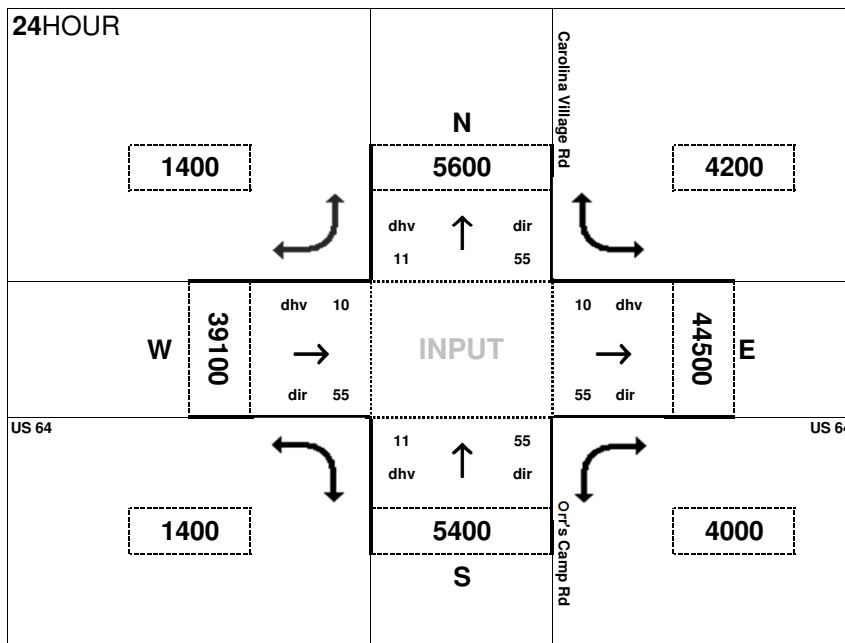

Peak Hour Volume Breakouts Report:

12a. US 64 & Carolina Village Rd / Orr's Camp Rd

Traffic Forecast Release Date:
February-12

Traffic Data Year:
2040 BY - No Build

Project:
STIP I-4400/4700 - I-26 Widening

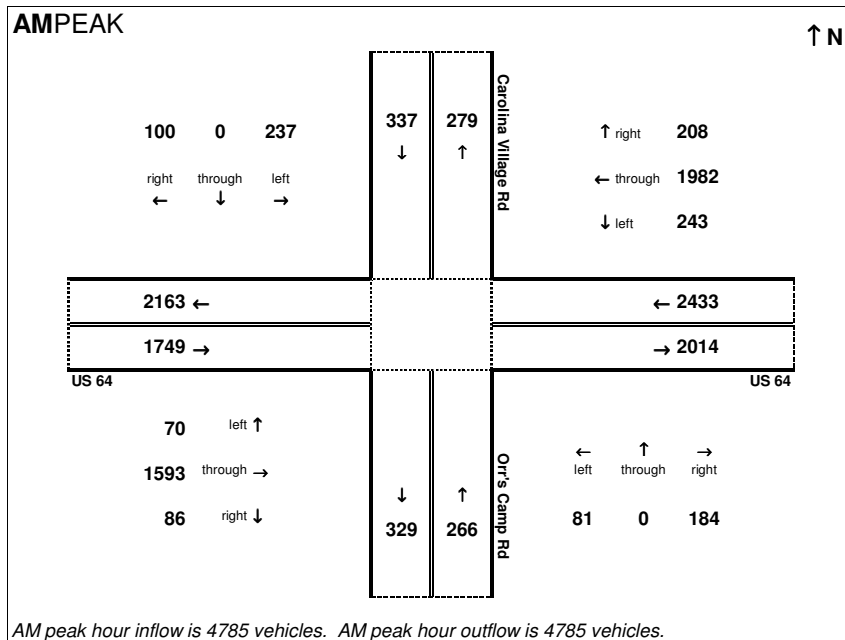

AM peak hour inflow is 4785 vehicles. AM peak hour outflow is 4785 vehicles.

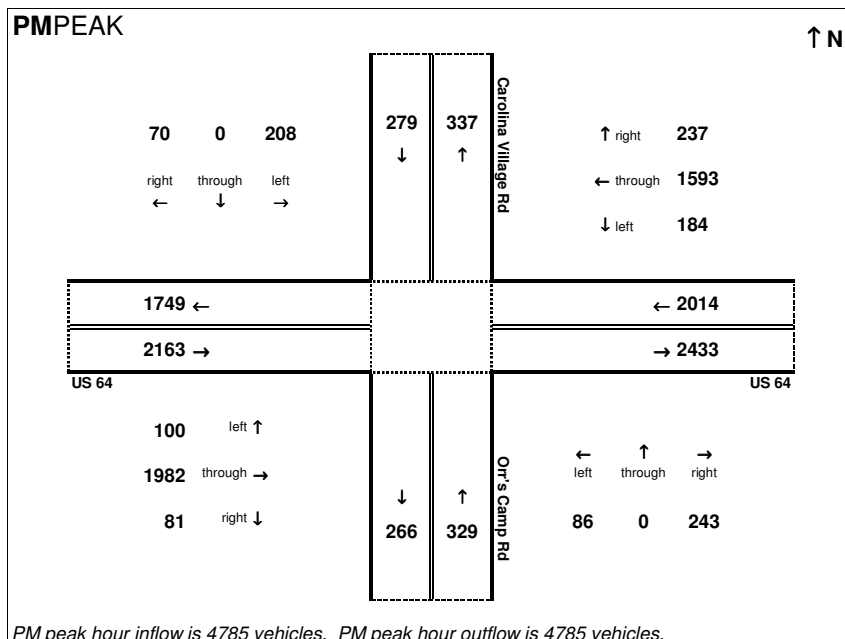

PM peak hour inflow is 4785 vehicles. PM peak hour outflow is 4785 vehicles.

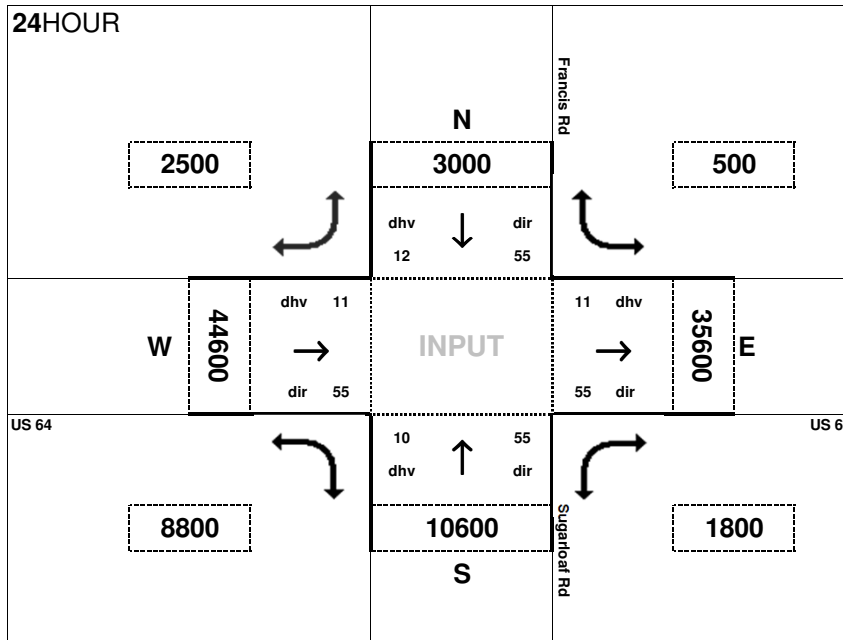

Peak Hour Volume Breakouts Report:
12b. US 64 & Francis Rd / Sugarloaf Rd

Traffic Forecast Release Date:
February-12

Traffic Data Year:
2040 BY - No Build

Project:
STIP I-4400/4700 - I-26 Widening

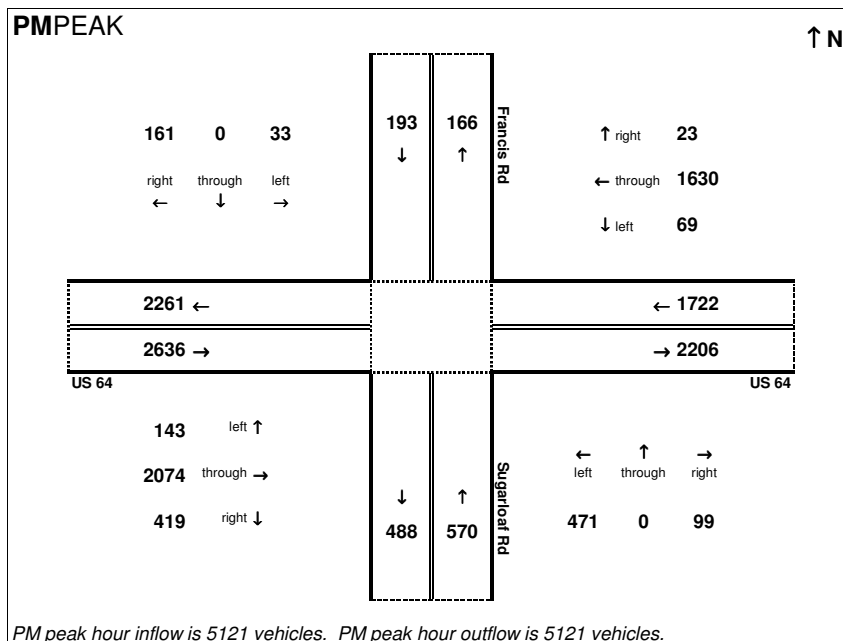
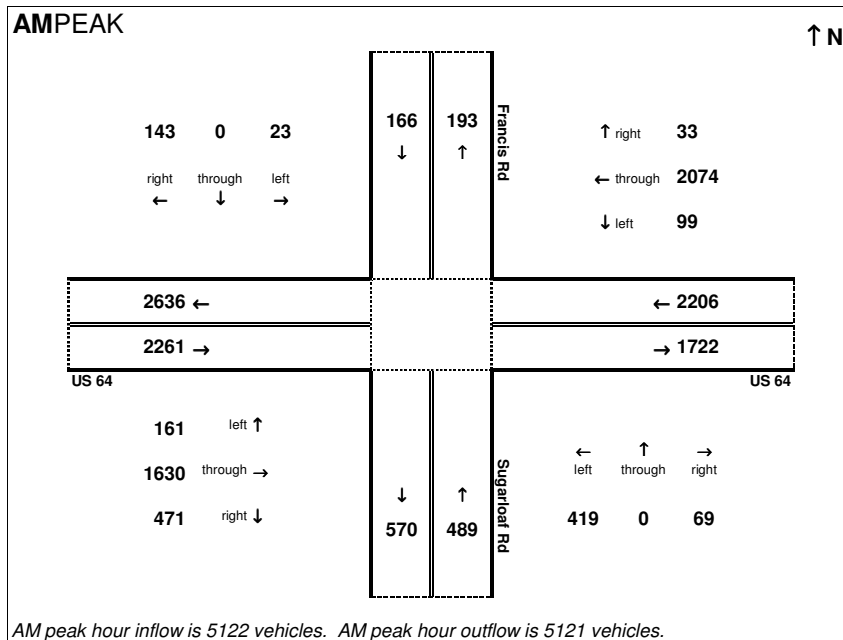

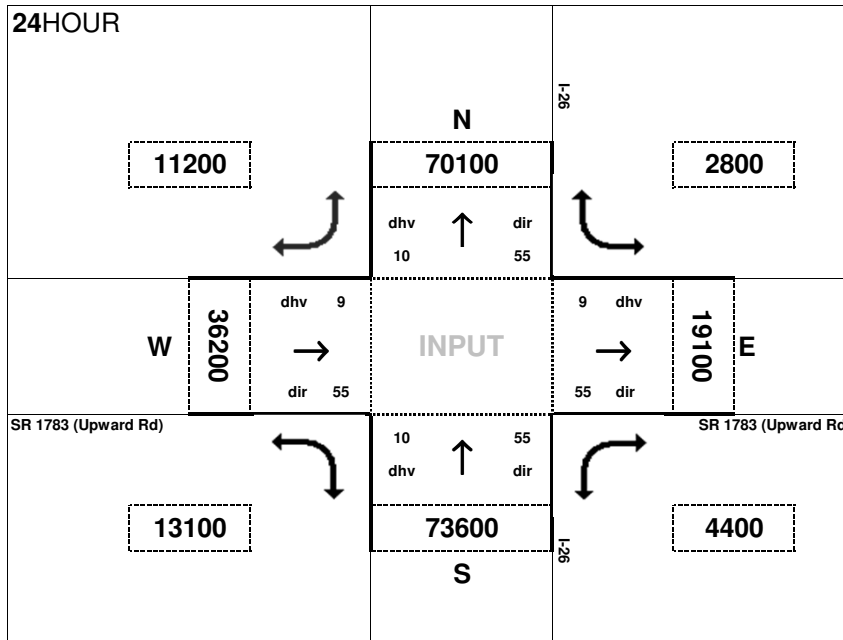

Peak Hour Volume Breakouts Report:
13. I-26 & Upward Road Interchange

Traffic Forecast Release Date:
February-12

Traffic Data Year:
2040 DY - No-Build

Project:
STIP I-4400/4700 - I-26 Widening

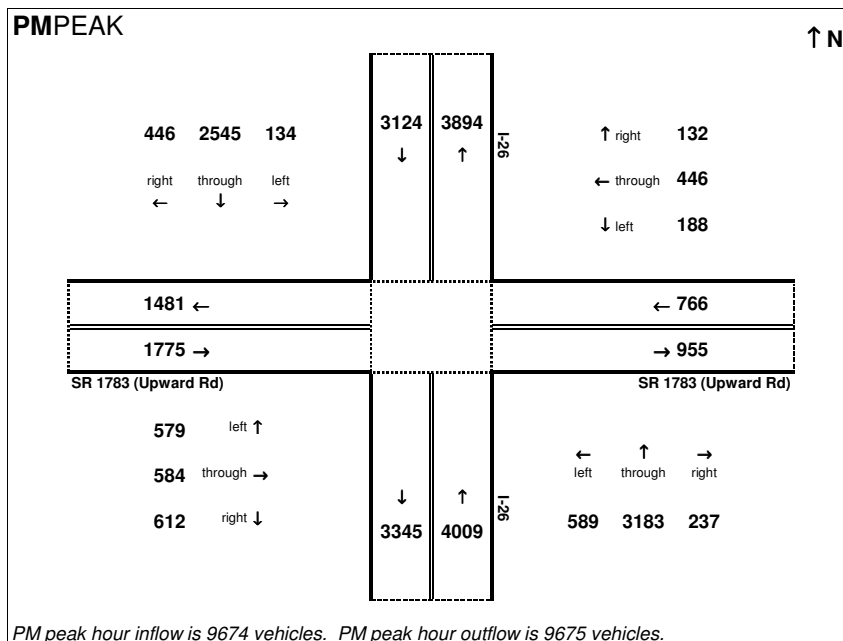
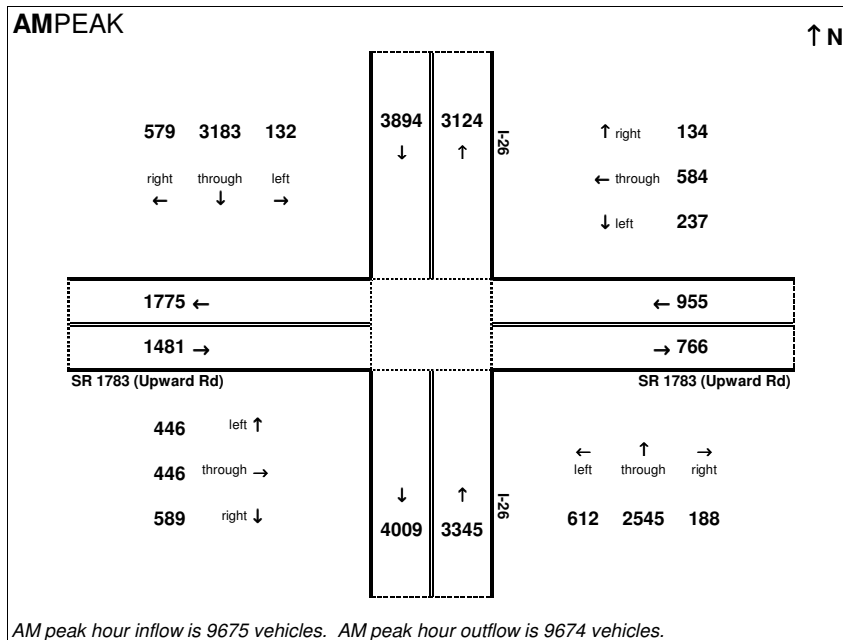

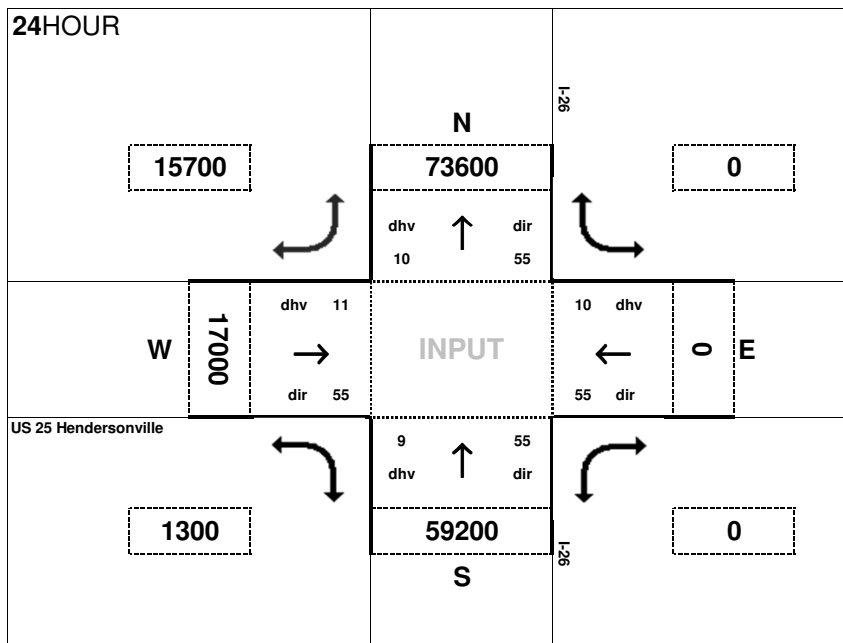

Peak Hour Volume Breakouts Report:
14. I-26 & US 25 Hendersonville Interchange

Traffic Forecast Release Date:
February-12

Traffic Data Year:
2040 DY - No-Build

Project:
STIP I-4400/4700 - I-26 Widening

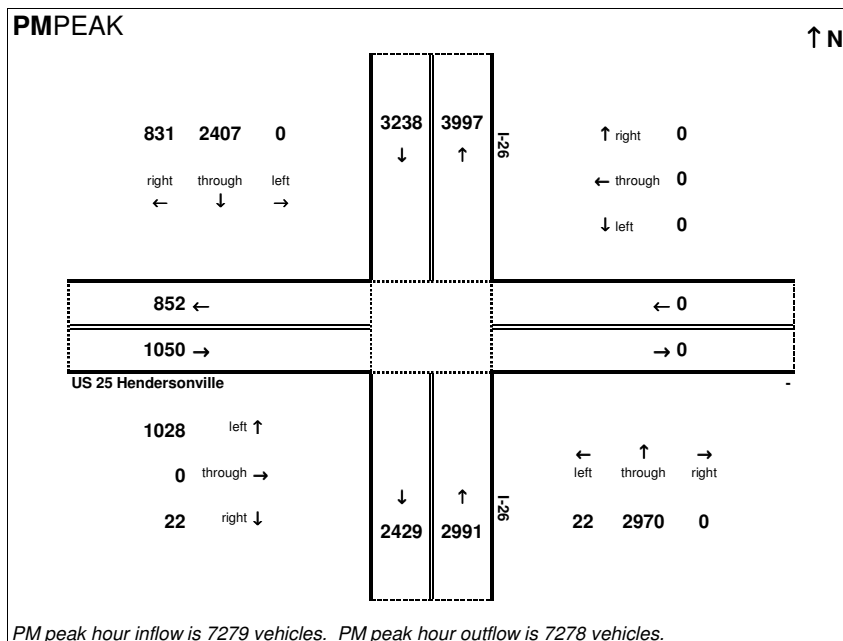
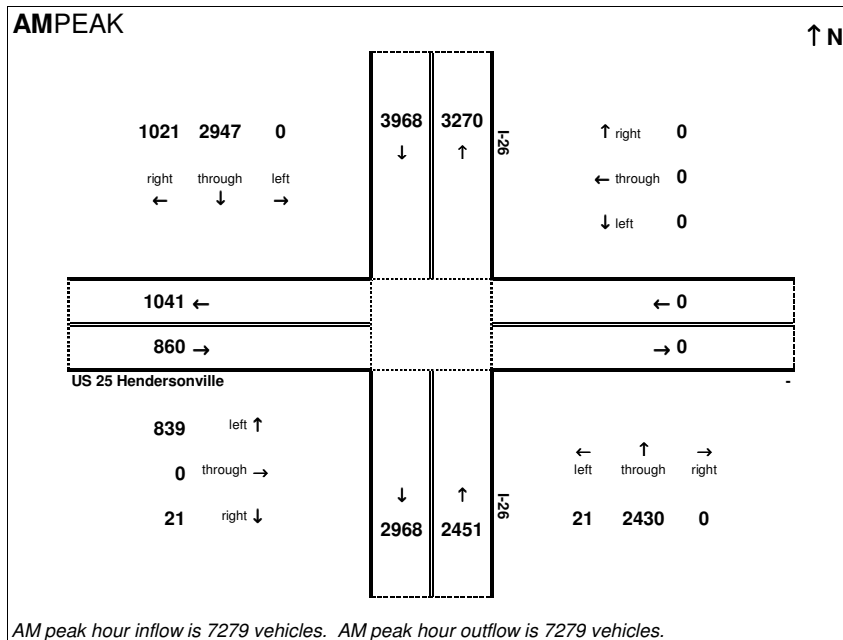

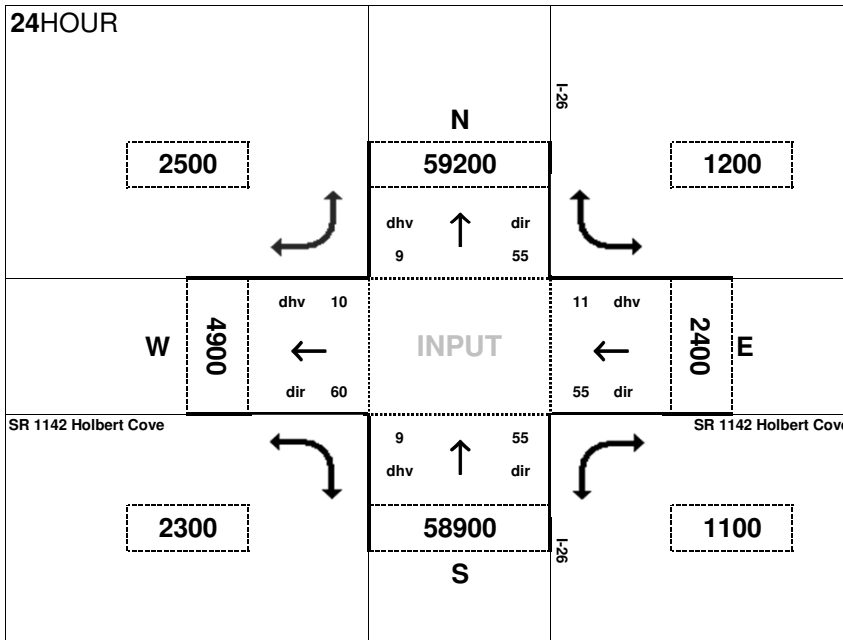

Peak Hour Volume Breakouts Report:
15. I-26 & Holbert Cove Rd Interchange

Traffic Forecast Release Date:
February-12

Traffic Data Year:
2040 DY - No-Build

Project:
STIP I-4400/4700 - I-26 Widening

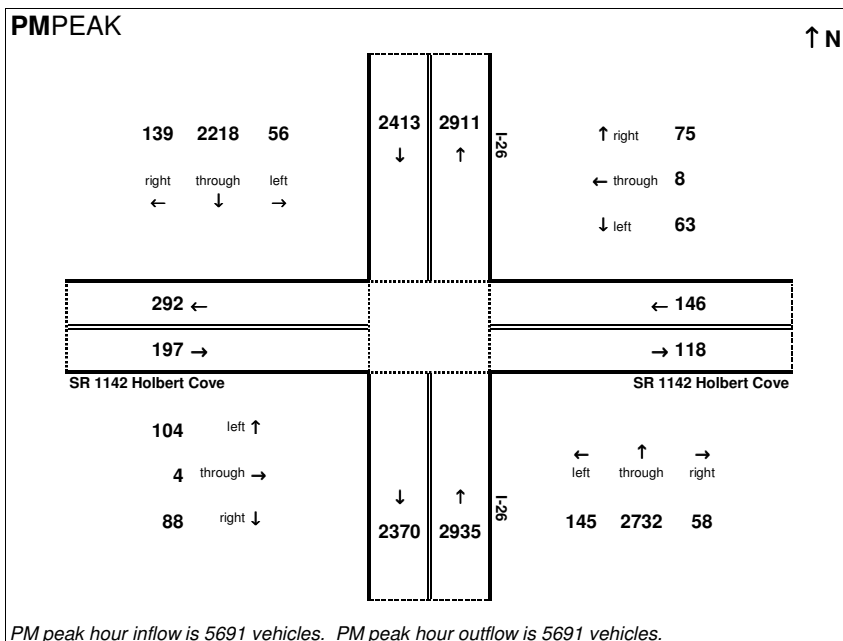
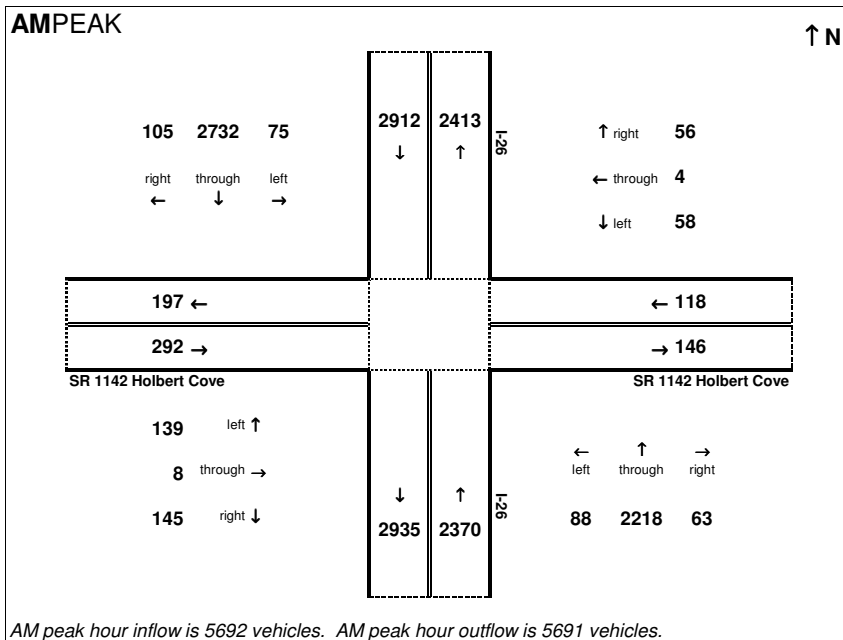

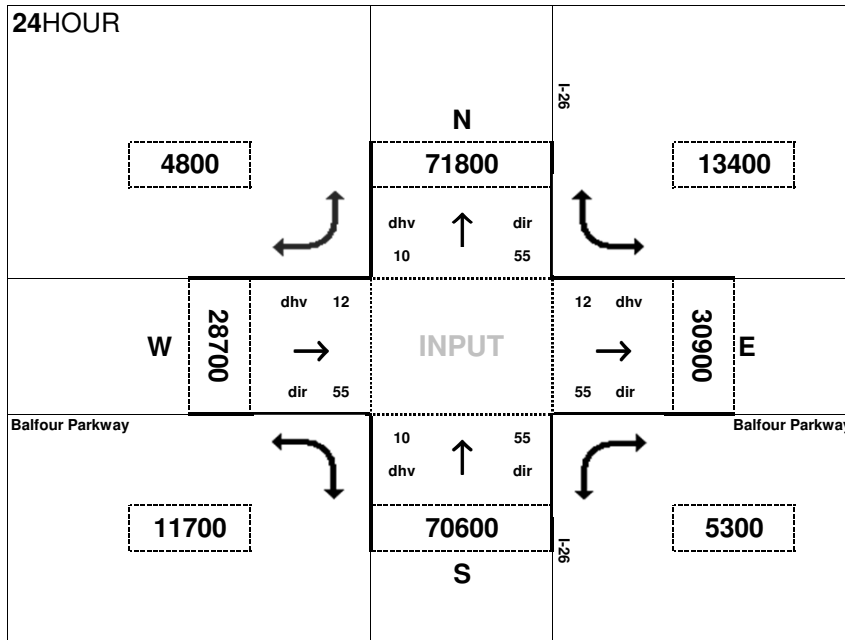

Peak Hour Volume Breakouts Report:

16. I-26 & Future Balfour Parkway Interchange

Traffic Forecast Release Date:
February-12

Traffic Data Year:
2040 DY - No-Build

Project:
STIP I-4400/4700 - I-26 Widening

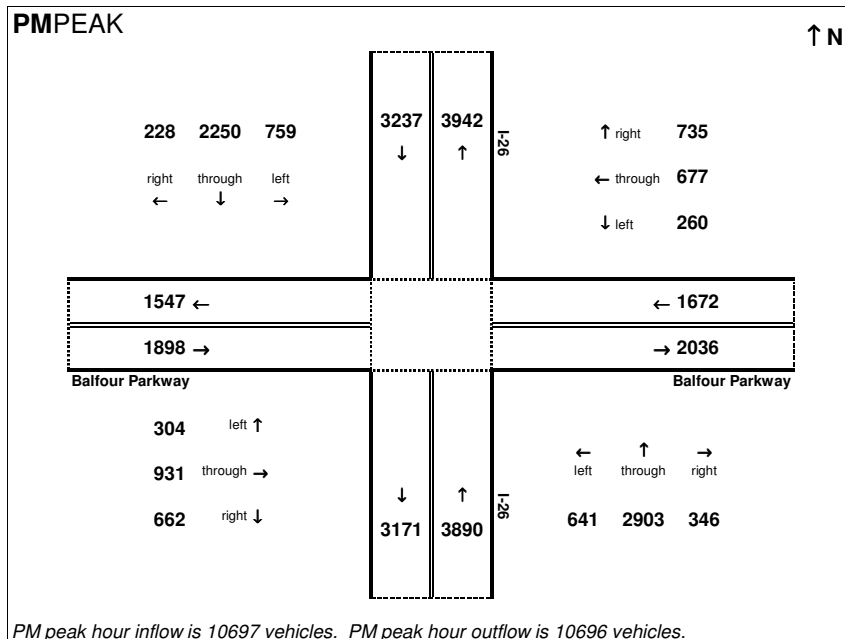
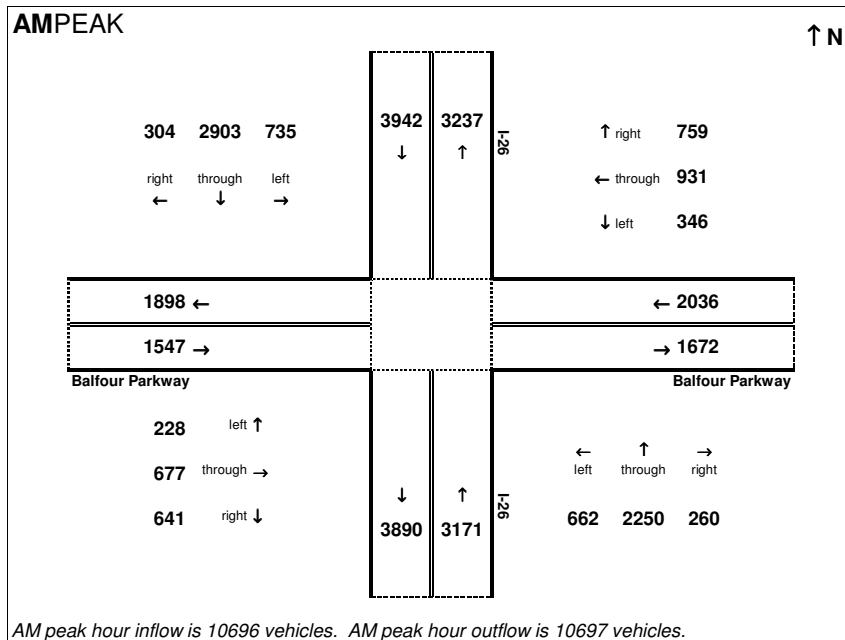

2040 Build 6 Lane

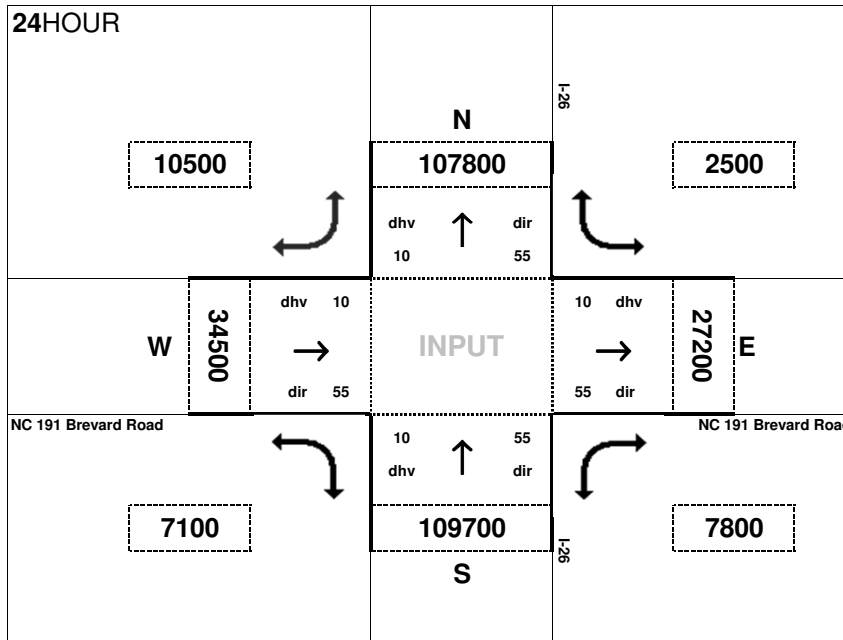

Peak Hour Volume Breakouts Report:
6. I-26 & NC 191 Interchange

Traffic Forecast Release Date:
February-12

Traffic Data Year:
2040 DY - Build 6 Ln

Project:
STIP I-4400/4700 - I-26 Widening

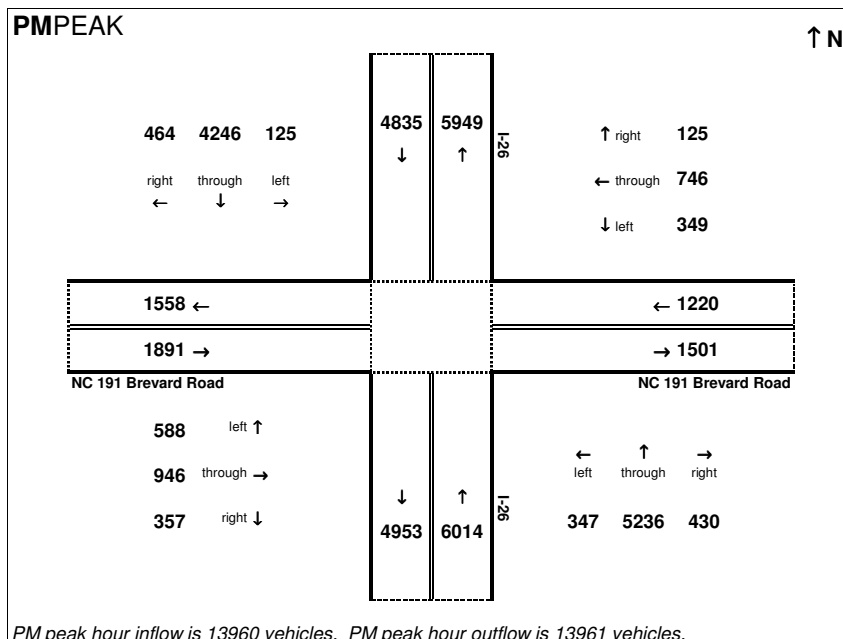
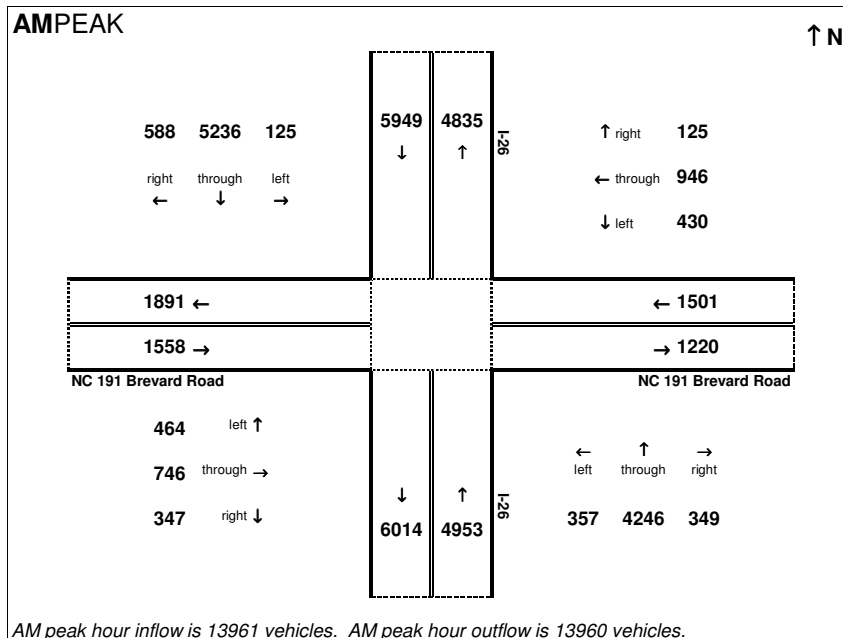

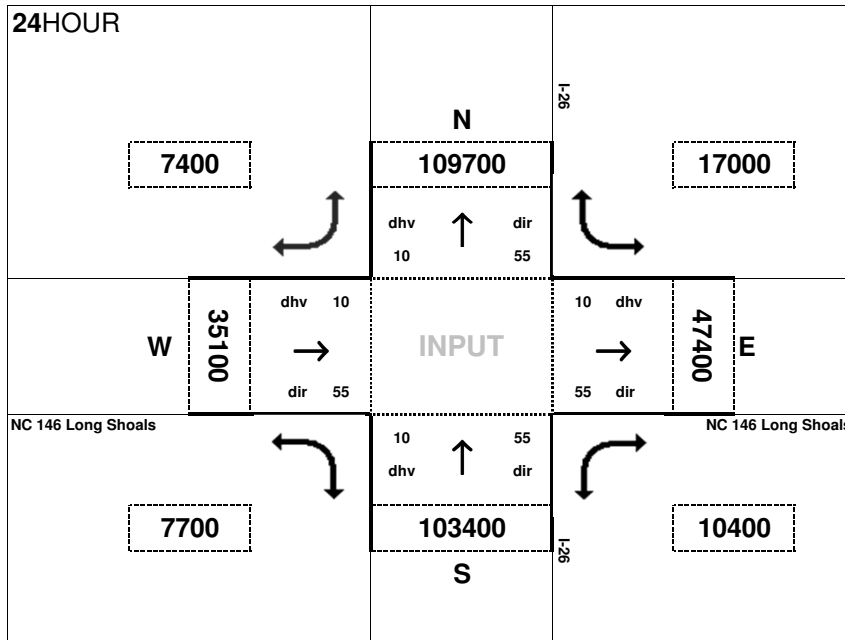

Peak Hour Volume Breakouts Report:
7. I-26 & NC 146 Interchange

Traffic Forecast Release Date:
February-12

Traffic Data Year:
2040 DY - Build 6 Ln

Project:
STIP I-4400/4700 - I-26 Widening

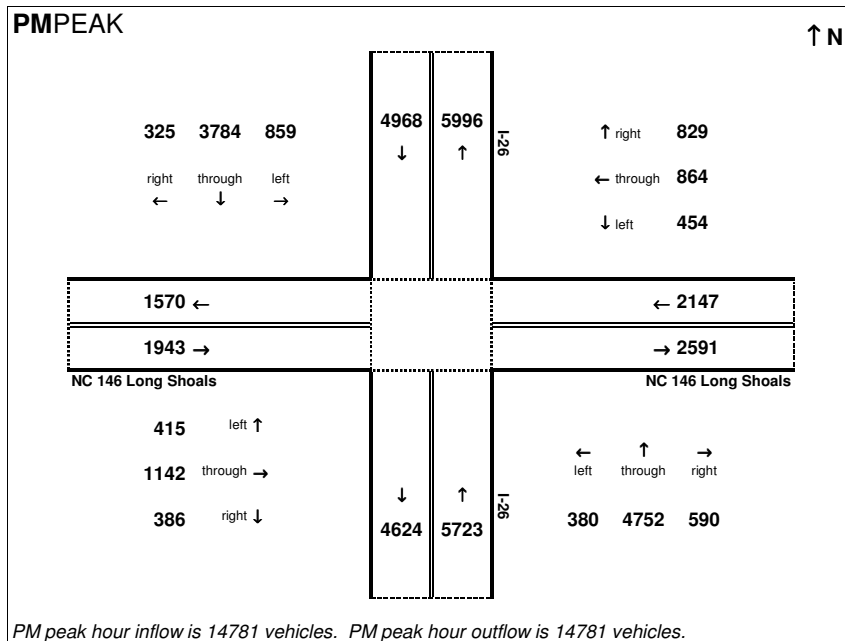
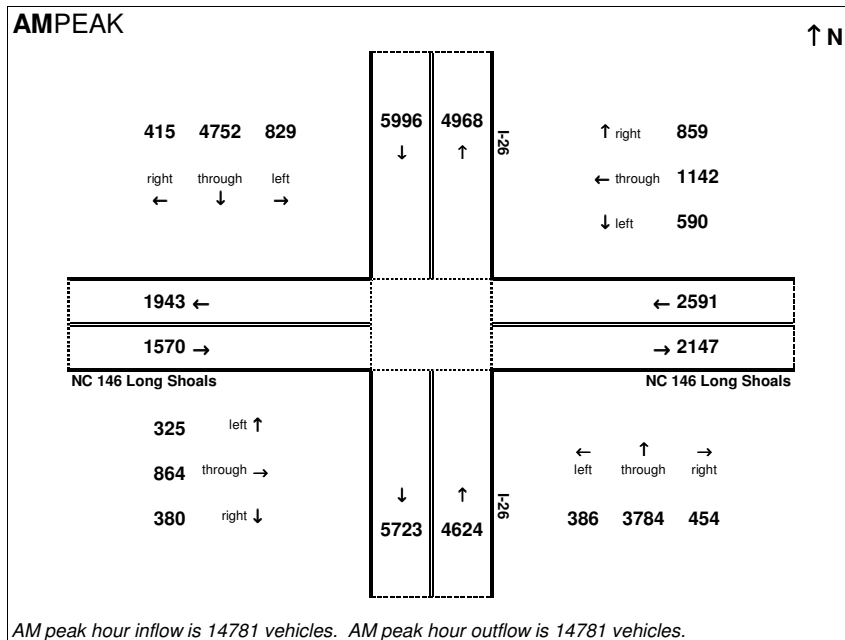

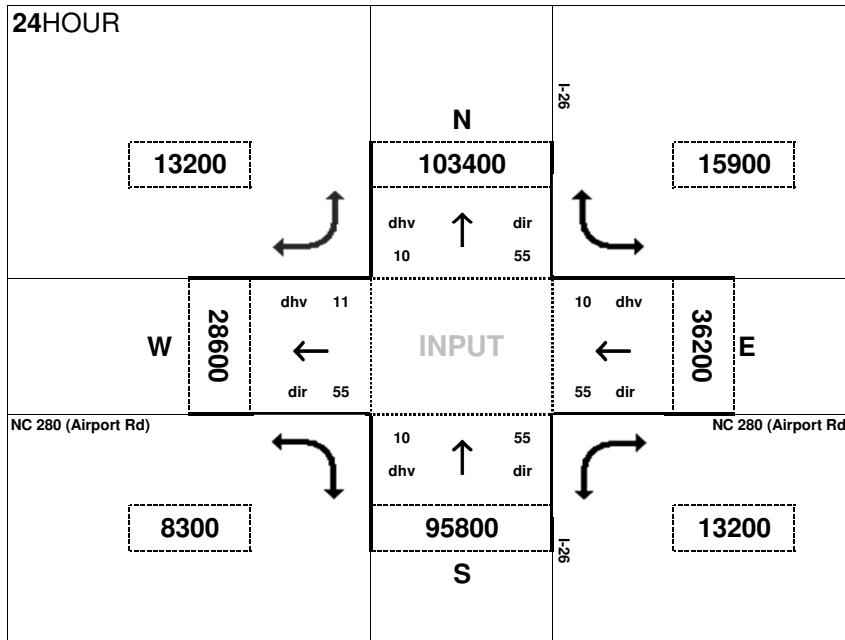

Peak Hour Volume Breakouts Report:
8. I-26 & NC 280 Interchange

Traffic Forecast Release Date:
February-12

Traffic Data Year:
2040 DY - Build 6 Ln

Project:
STIP I-4400/4700 - I-26 Widening

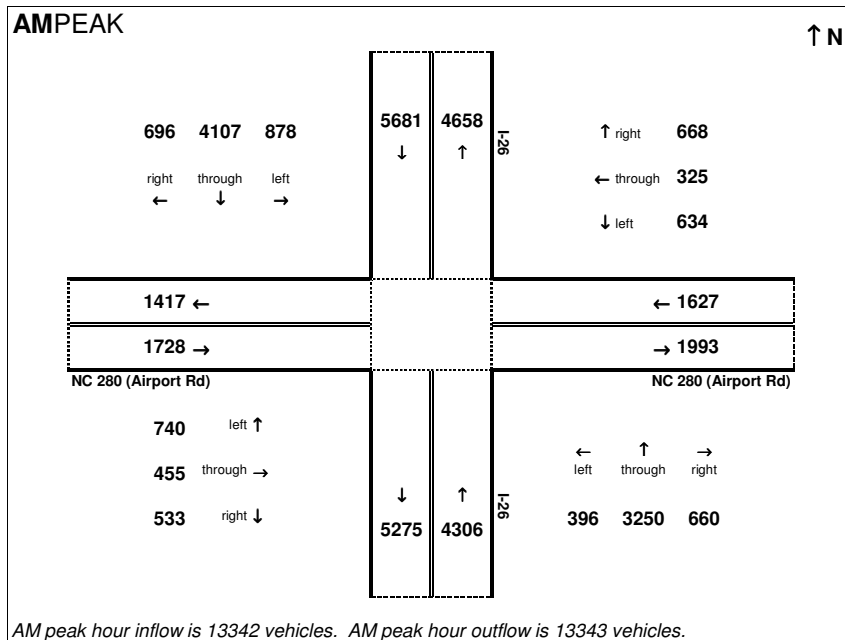

AM peak hour inflow is 13342 vehicles. AM peak hour outflow is 13343 vehicles.

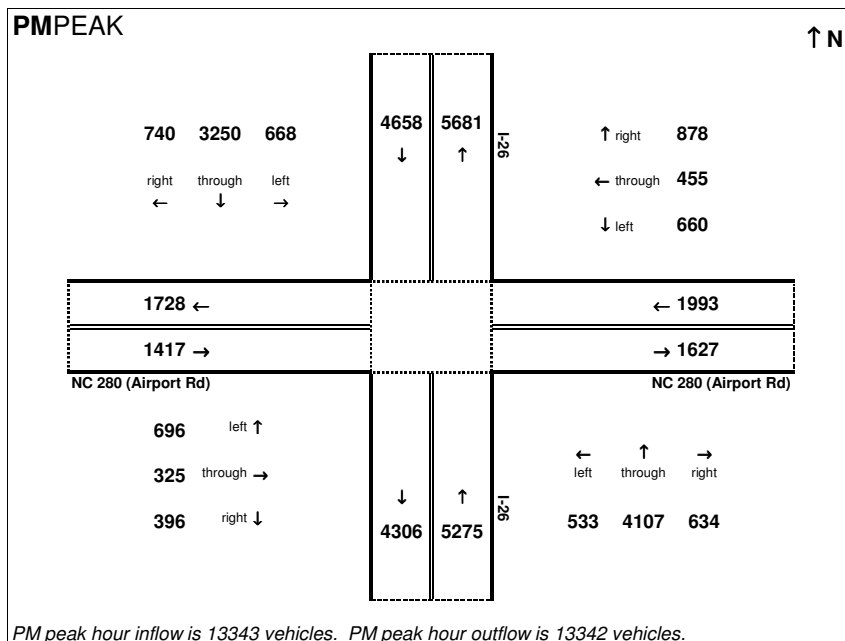

PM peak hour inflow is 13343 vehicles. PM peak hour outflow is 13342 vehicles.

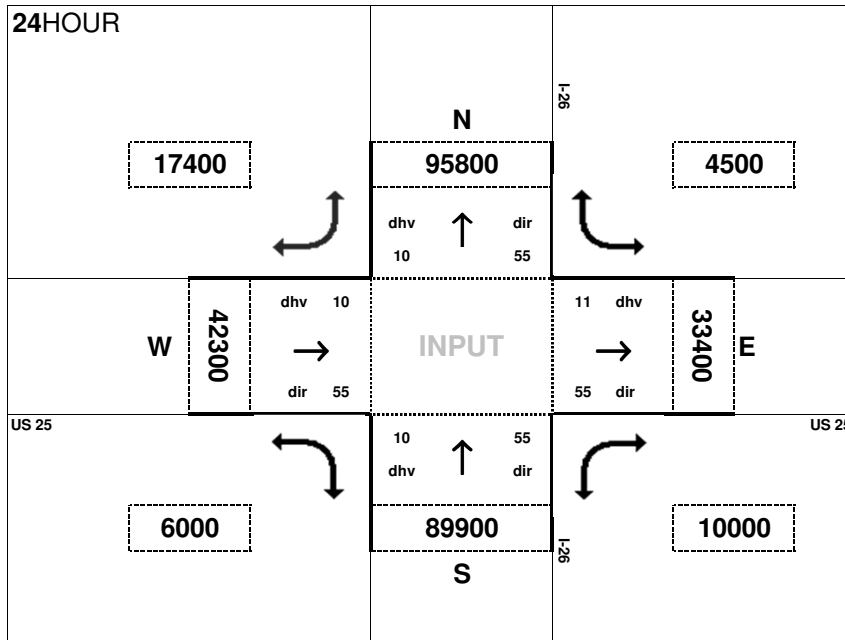

Peak Hour Volume Breakouts Report:

10. I-26 & US 25 Interchange

Traffic Forecast Release Date:

February-12

Traffic Data Year:

2040 DY - Build 6 Ln

Project:

STIP I-4400/4700 - I-26 Widening

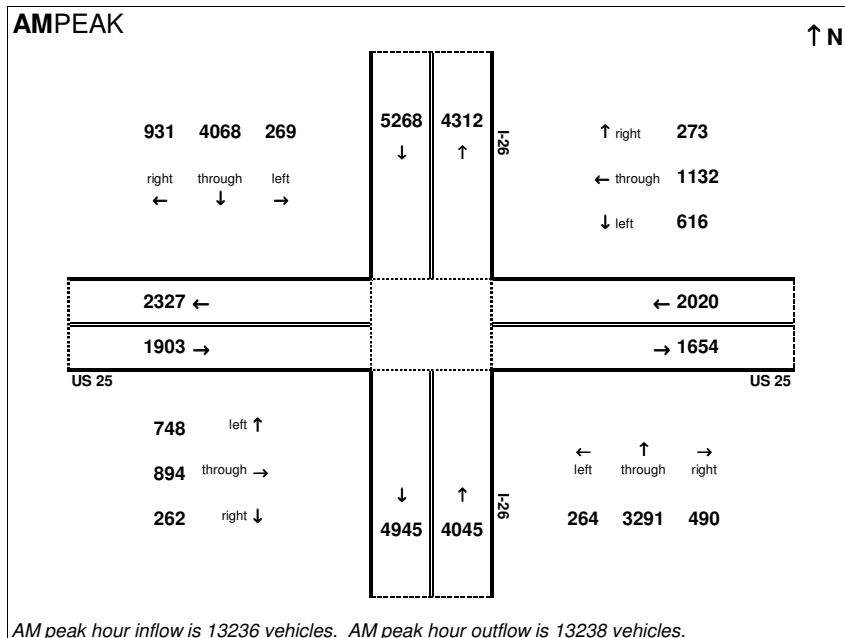

AM peak hour inflow is 13236 vehicles. AM peak hour outflow is 13238 vehicles.

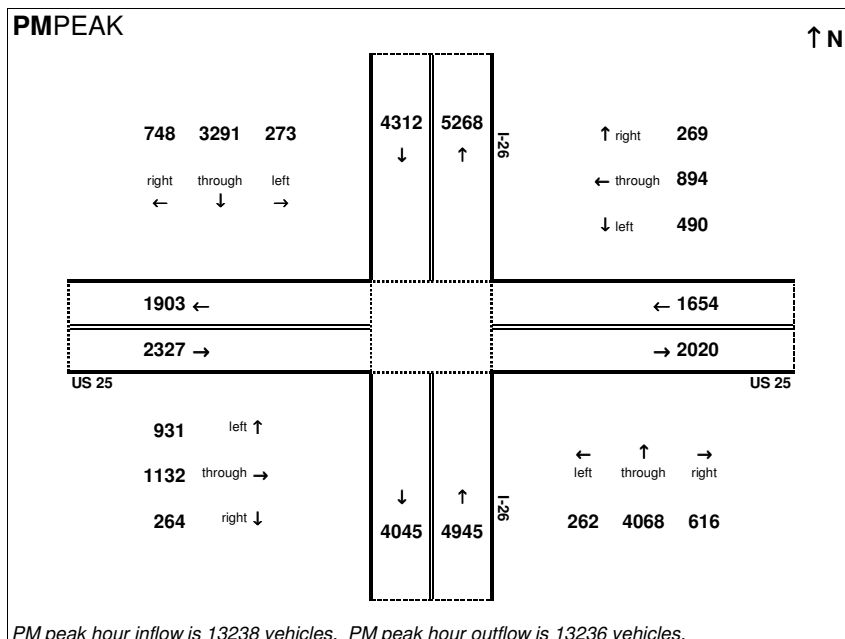

PM peak hour inflow is 13238 vehicles. PM peak hour outflow is 13236 vehicles.

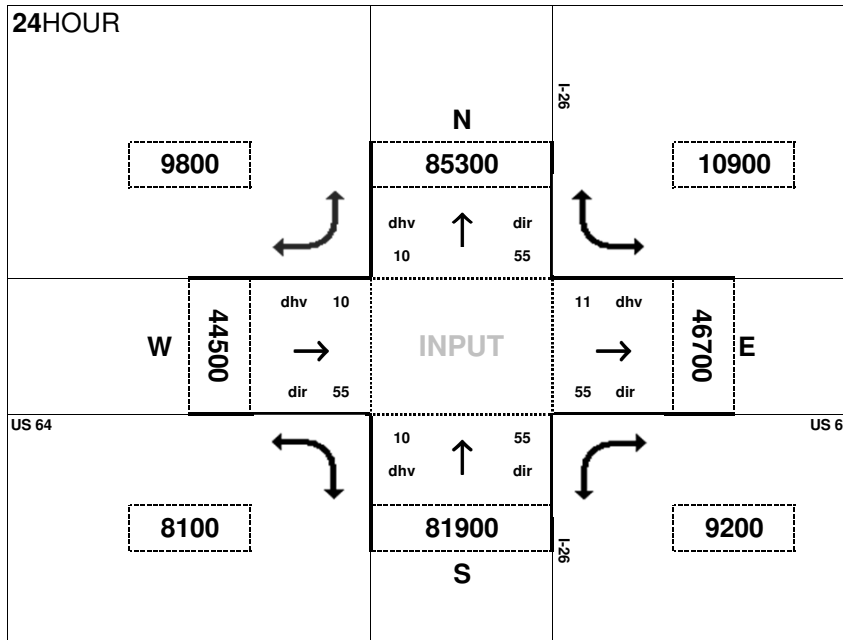

Peak Hour Volume Breakouts Report:
12. I-26 & US 64 System Interchange

Traffic Forecast Release Date:
February-12

Traffic Data Year:
2040 DY - Build 6 Ln

Project:
STIP I-4400/4700 - I-26 Widening

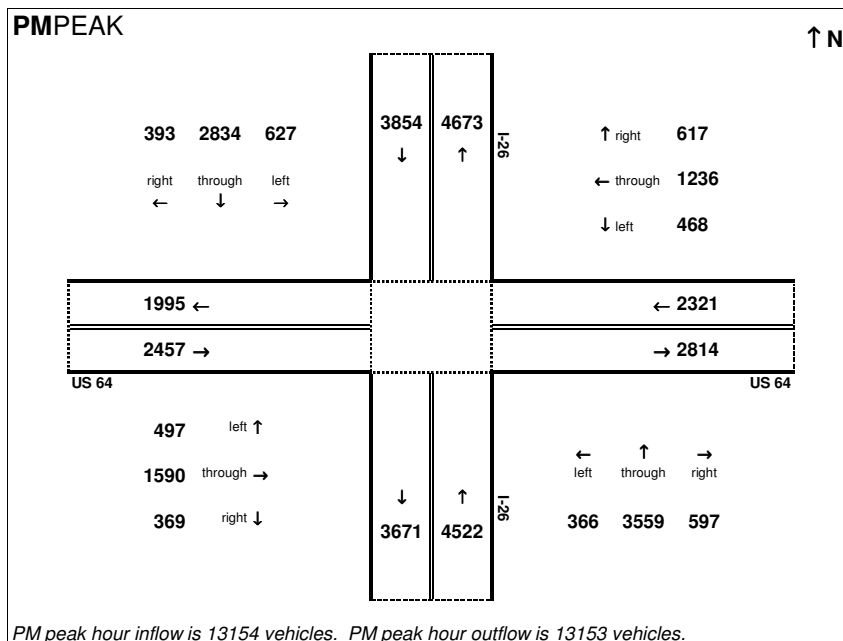
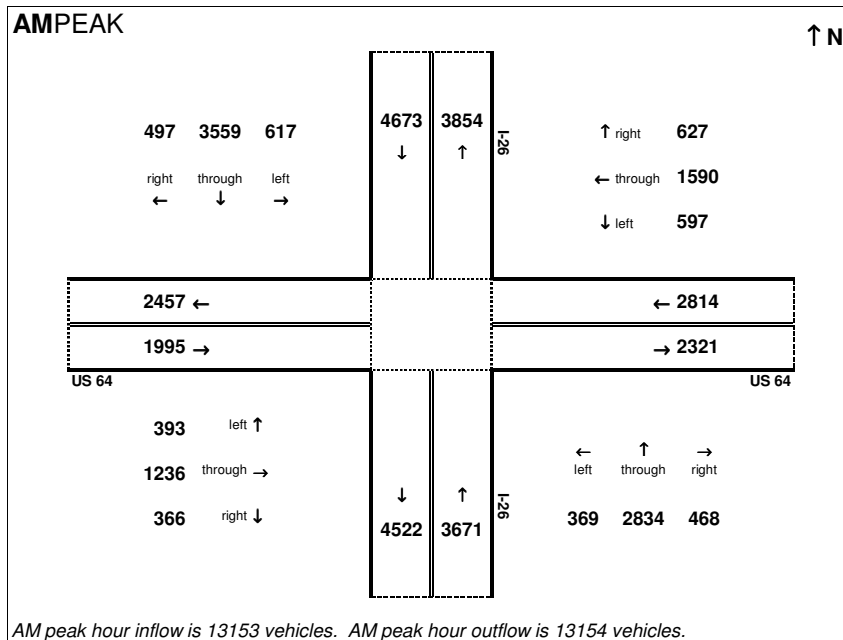

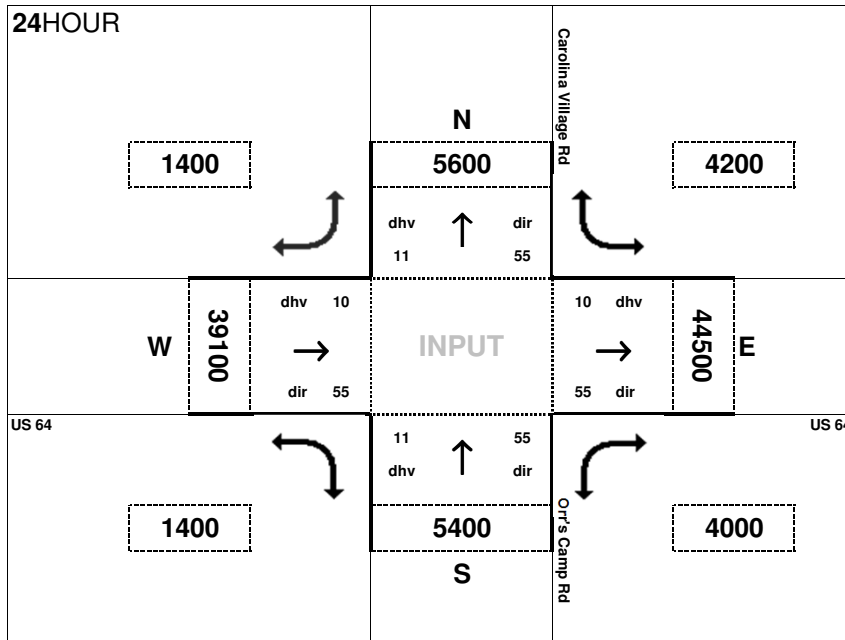

Peak Hour Volume Breakouts Report:

12a. US 64 & Carolina Village Rd / Orr's Camp Rd

Traffic Forecast Release Date:
February-12

Traffic Data Year:
2040 BY - Bui6 Lanes

Project:
STIP I-4400/4700 - I-26 Widening

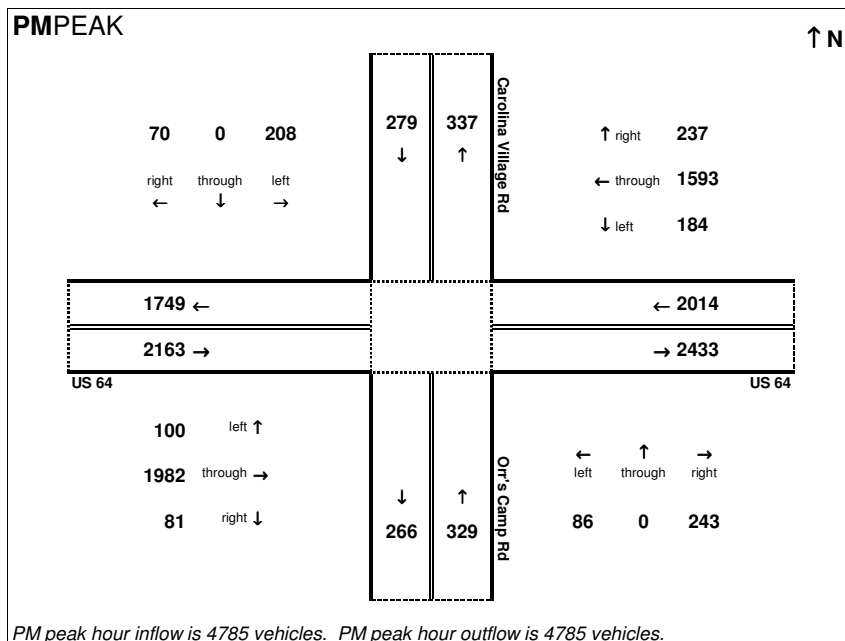
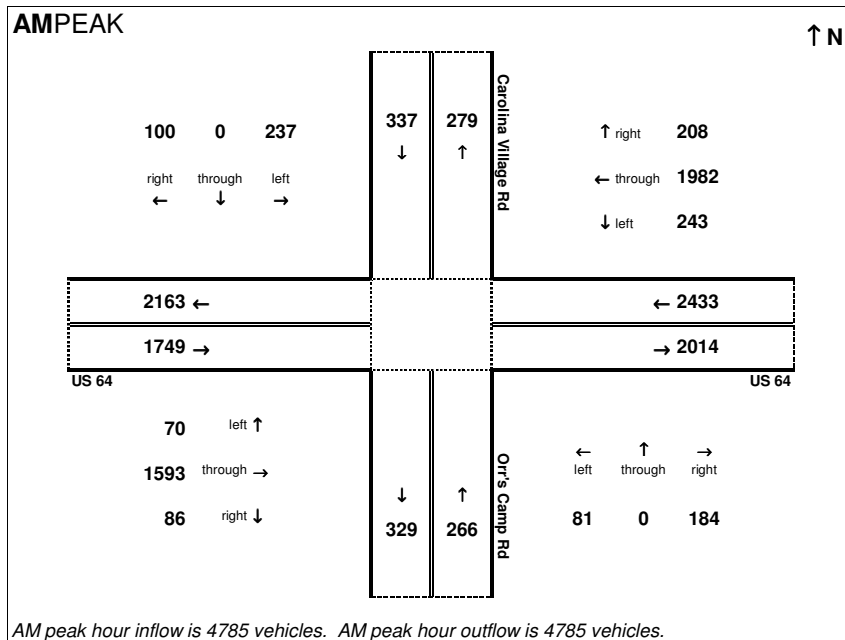

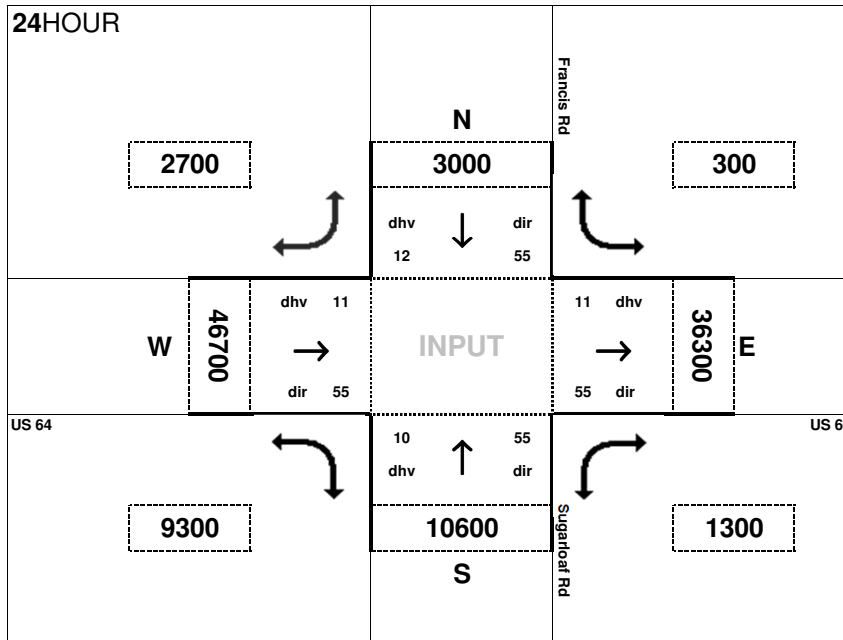

Peak Hour Volume Breakouts Report:
12b. US 64 & Francis Rd / Sugarloaf Rd

Traffic Forecast Release Date:
February-12

Traffic Data Year:
2040 BY - 6 Lanes

Project:
STIP I-4400/4700 - I-26 Widening

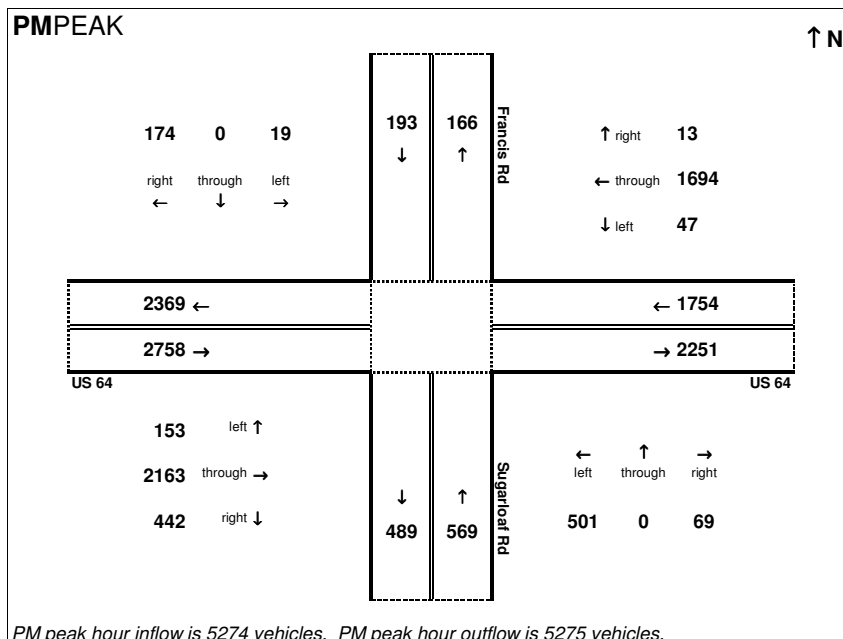
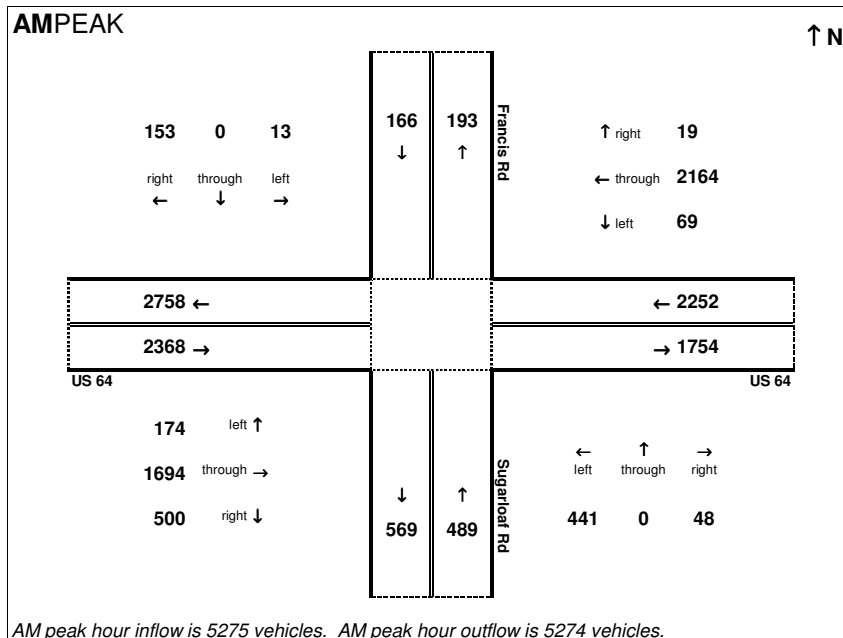

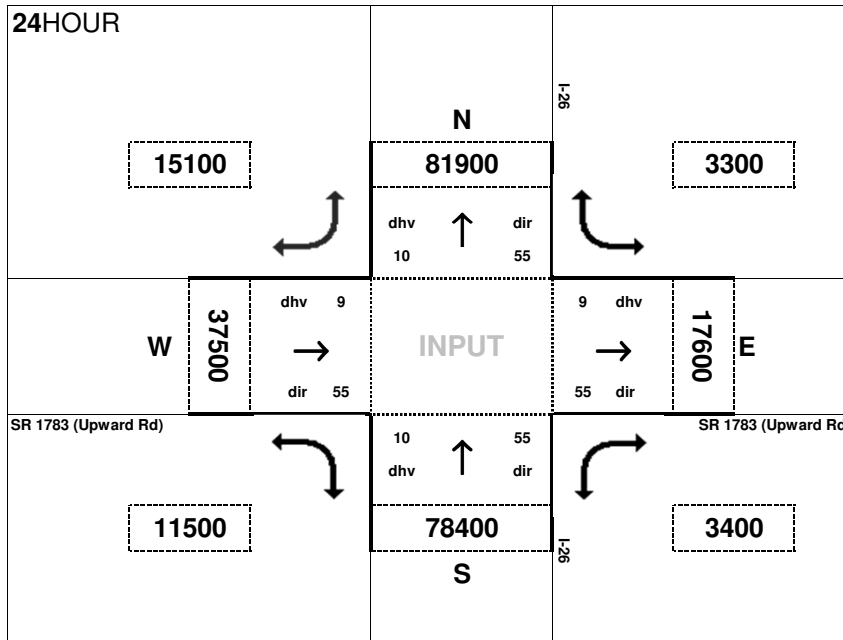

Peak Hour Volume Breakouts Report:
13. I-26 & Upward Road Interchange

Traffic Forecast Release Date:
February-12

Traffic Data Year:
2040 DY - Build 6 Ln

Project:
STIP I-4400/4700 - I-26 Widening

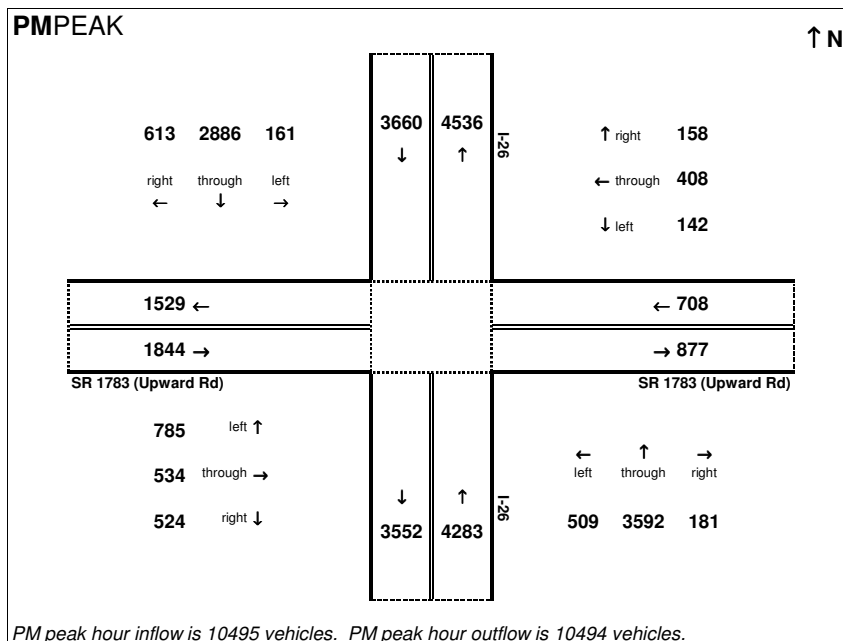
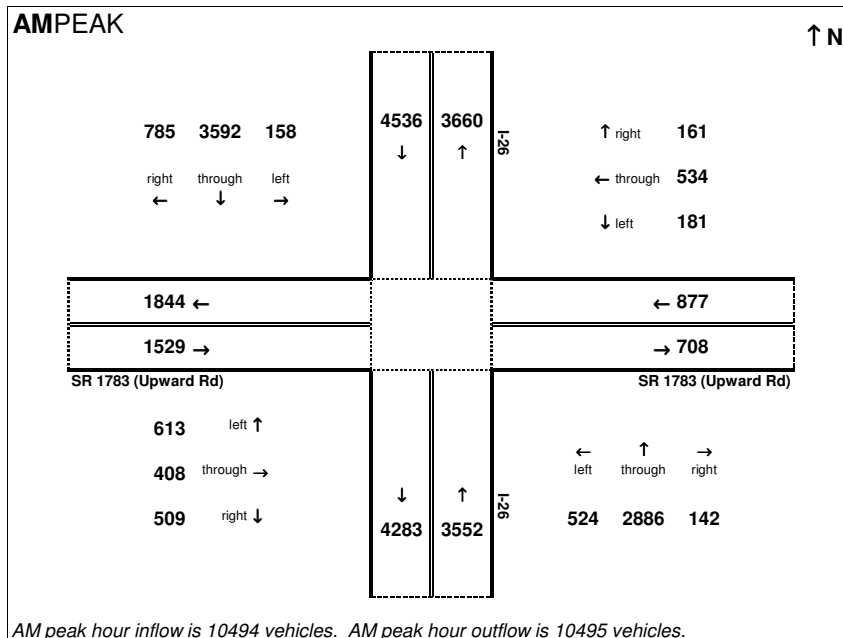

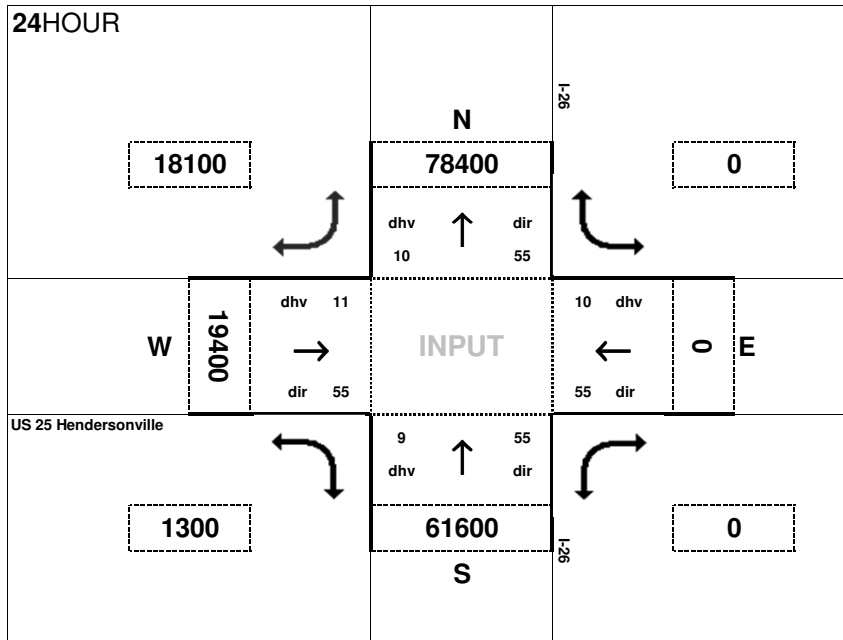

Peak Hour Volume Breakouts Report:
14. I-26 & US 25 Hendersonville Interchange

Traffic Forecast Release Date:
February-12

Traffic Data Year:
2040 DY - Build 6 Ln

Project:
STIP I-4400/4700 - I-26 Widening

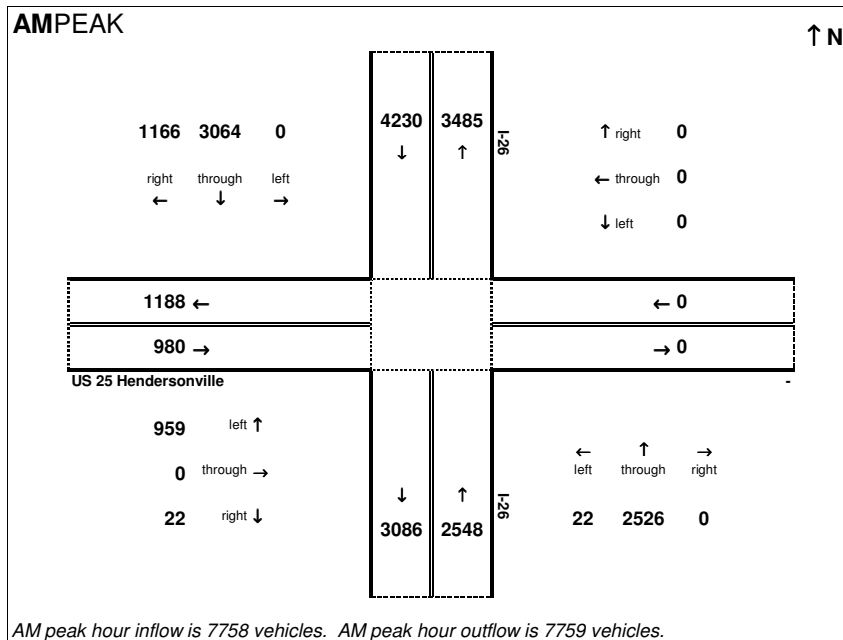

AM peak hour inflow is 7758 vehicles. AM peak hour outflow is 7759 vehicles.

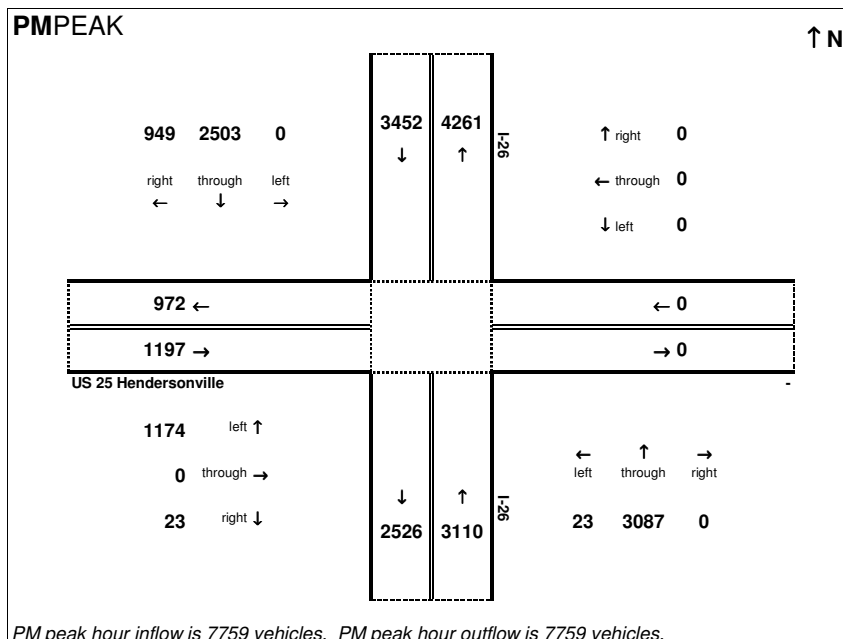

PM peak hour inflow is 7759 vehicles. PM peak hour outflow is 7759 vehicles.

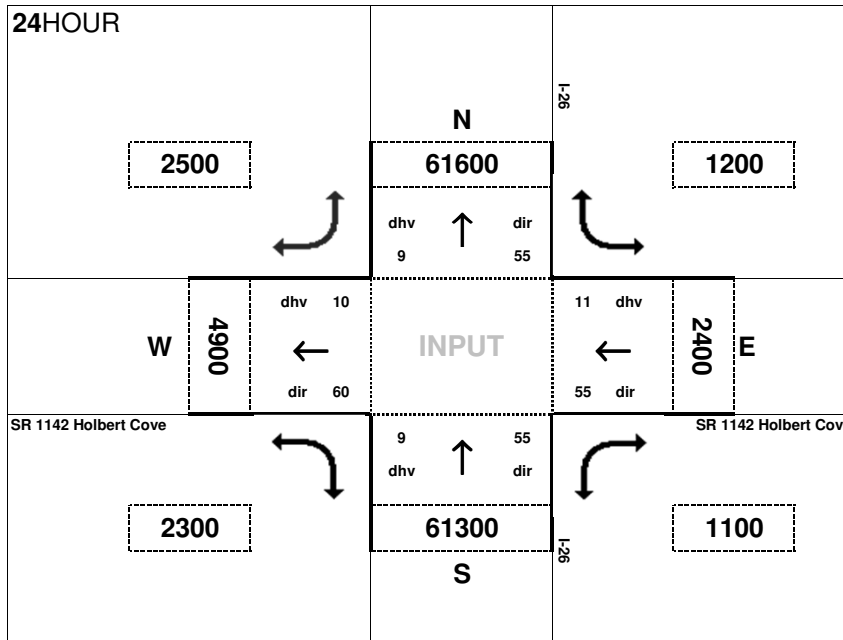

Peak Hour Volume Breakouts Report:
15. I-26 & Holbert Cove Rd Interchange

Traffic Forecast Release Date:
February-12

Traffic Data Year:
2040 DY - Build 6 Ln

Project:
STIP I-4400/4700 - I-26 Widening

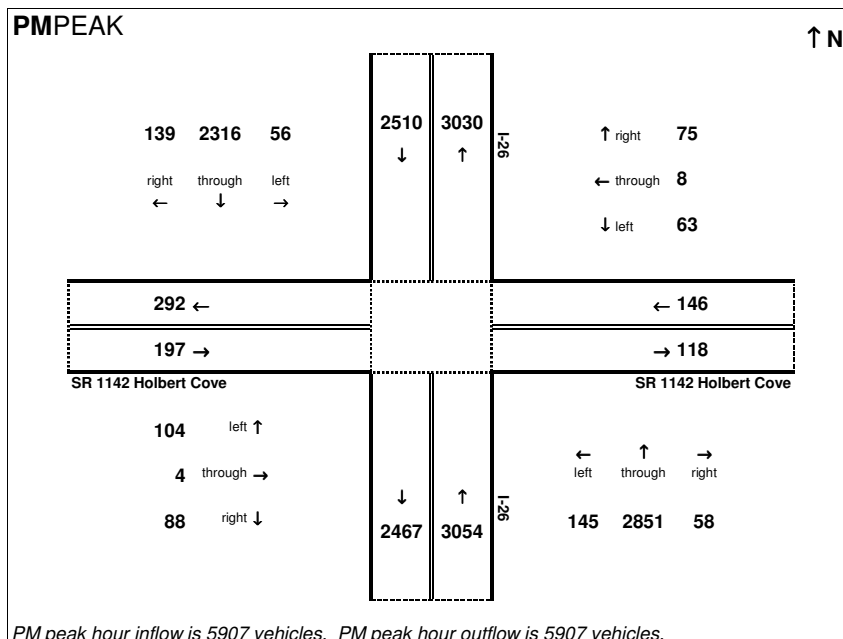
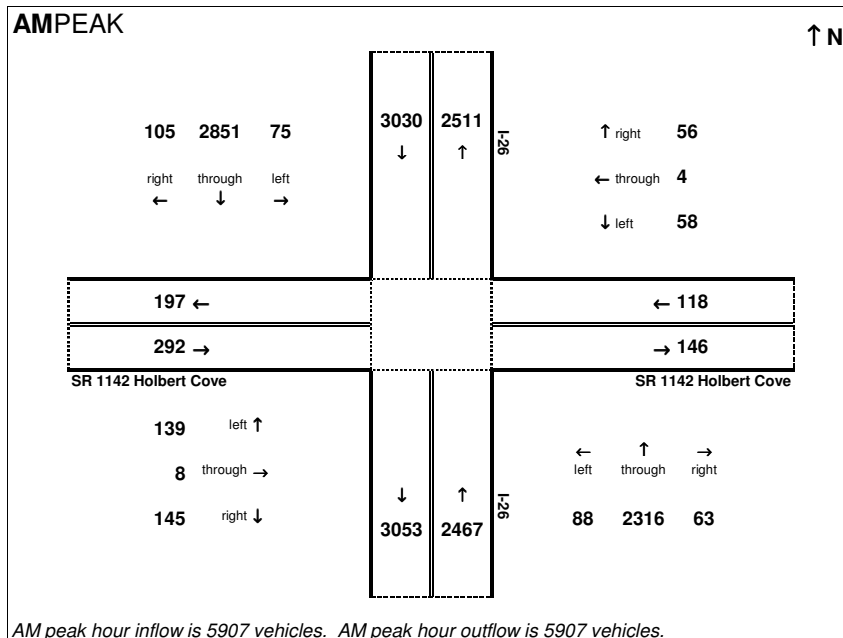

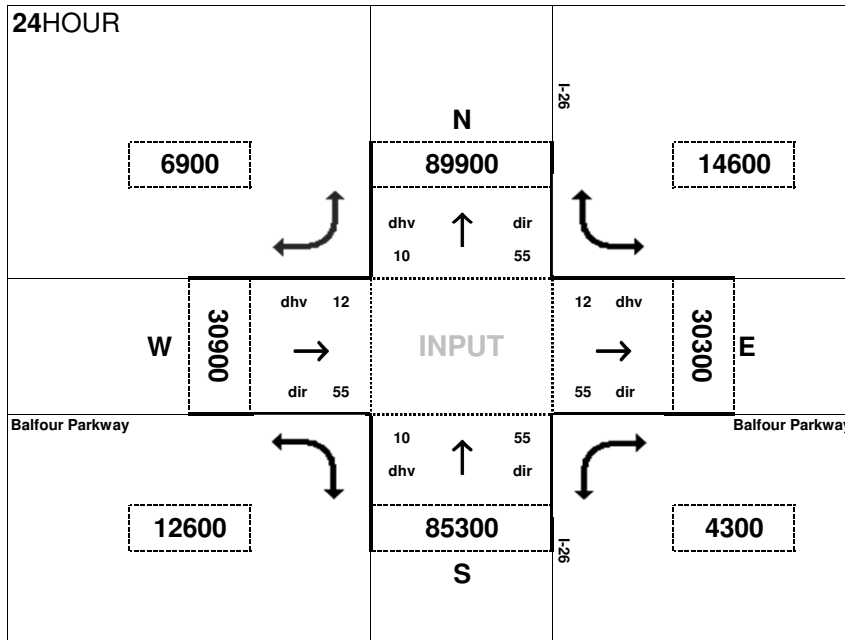

Peak Hour Volume Breakouts Report:

16. I-26 & Future Balfour Parkway Interchange

Traffic Forecast Release Date:
February-12

Traffic Data Year:
2040 DY - Build 6 Ln

Project:
STIP I-4400/4700 - I-26 Widening

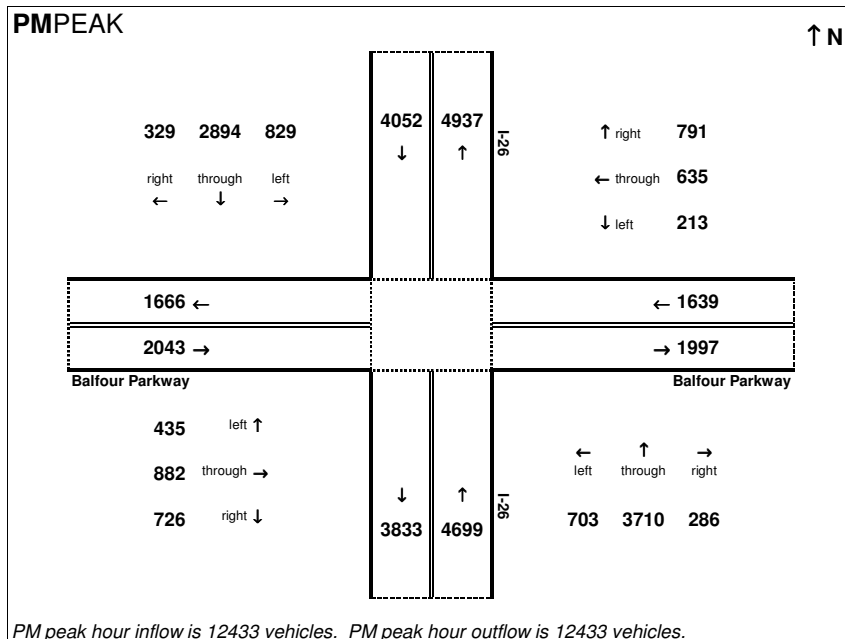
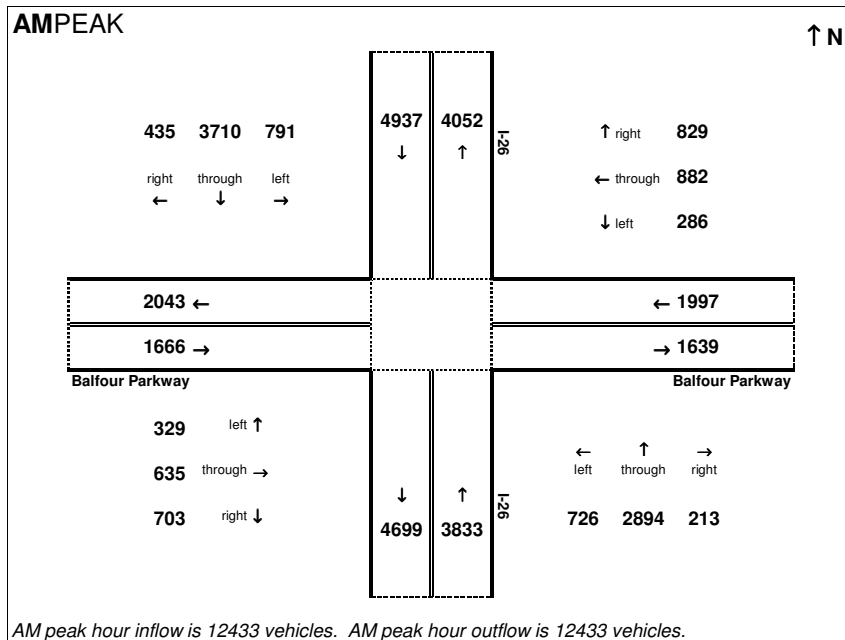

2040 Build 8 Lane

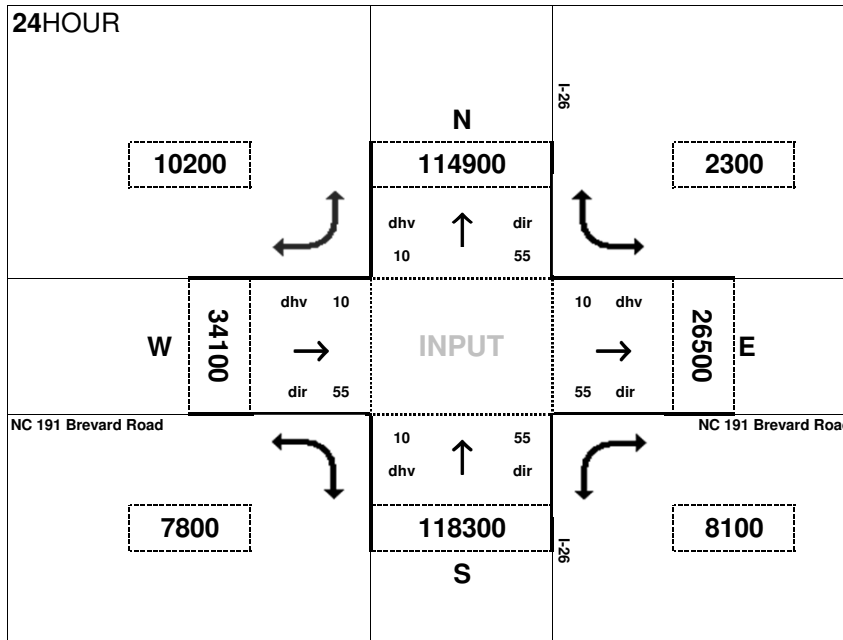

Peak Hour Volume Breakouts Report:
6. I-26 & NC 191 Interchange

Traffic Forecast Release Date:
February-12

Traffic Data Year:
2040 DY - Build 8 Ln

Project:
STIP I-4400/4700 - I-26 Widening

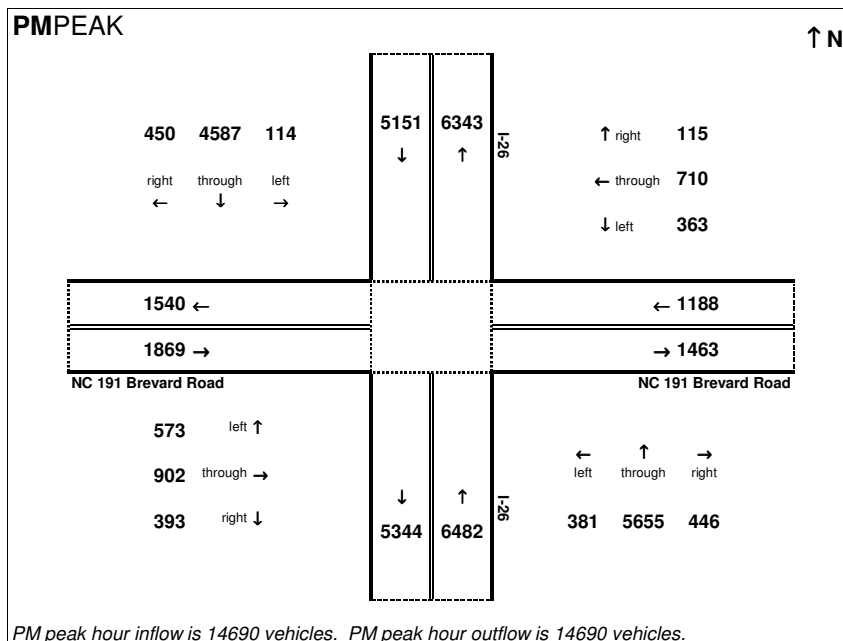
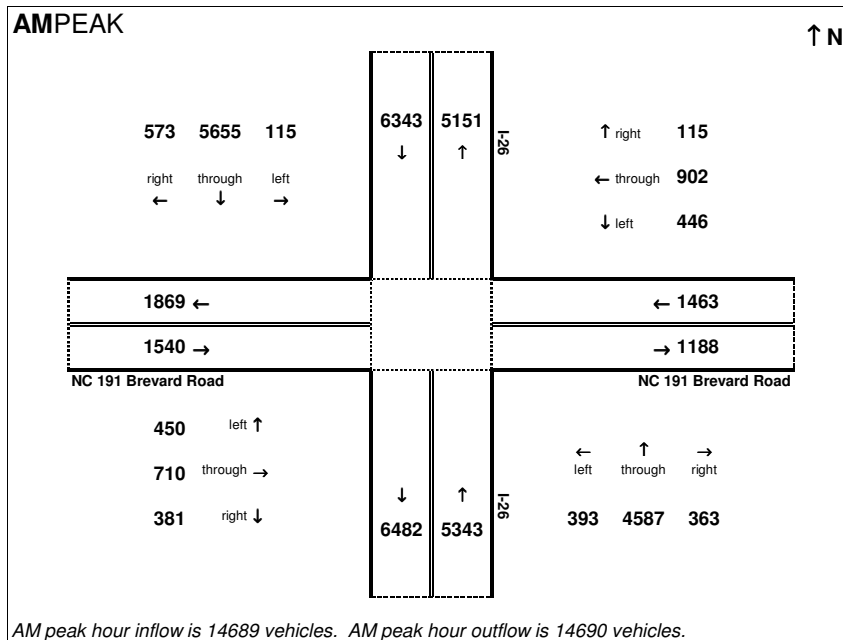

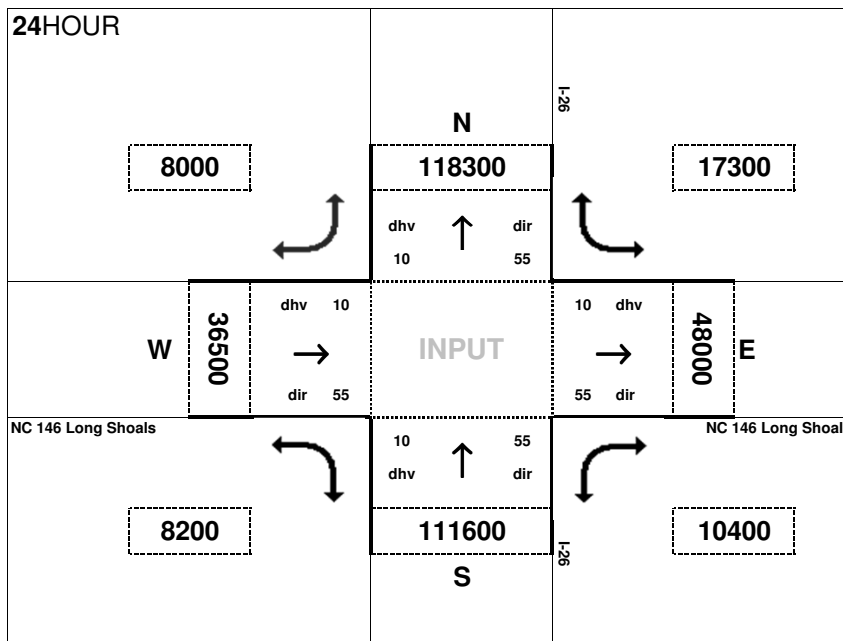

Peak Hour Volume Breakouts Report:
7. I-26 & NC 146 Interchange

Traffic Forecast Release Date:
February-12

Traffic Data Year:
2040 DY - Build 8 Ln

Project:
STIP I-4400/4700 - I-26 Widening

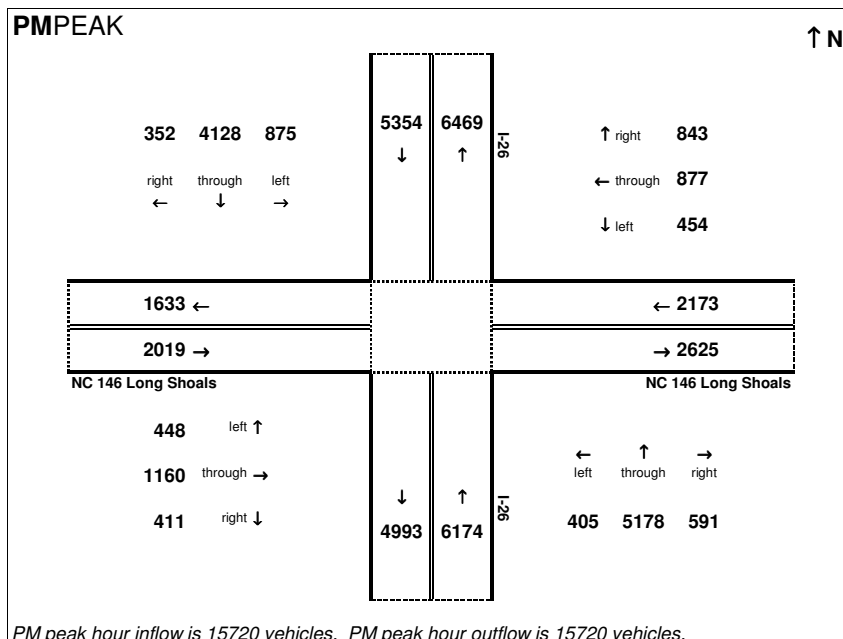
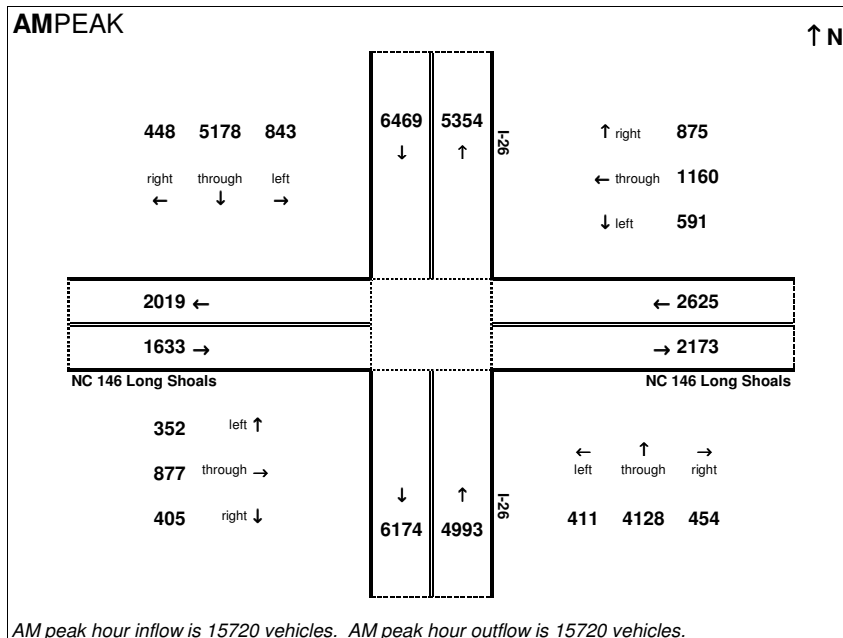

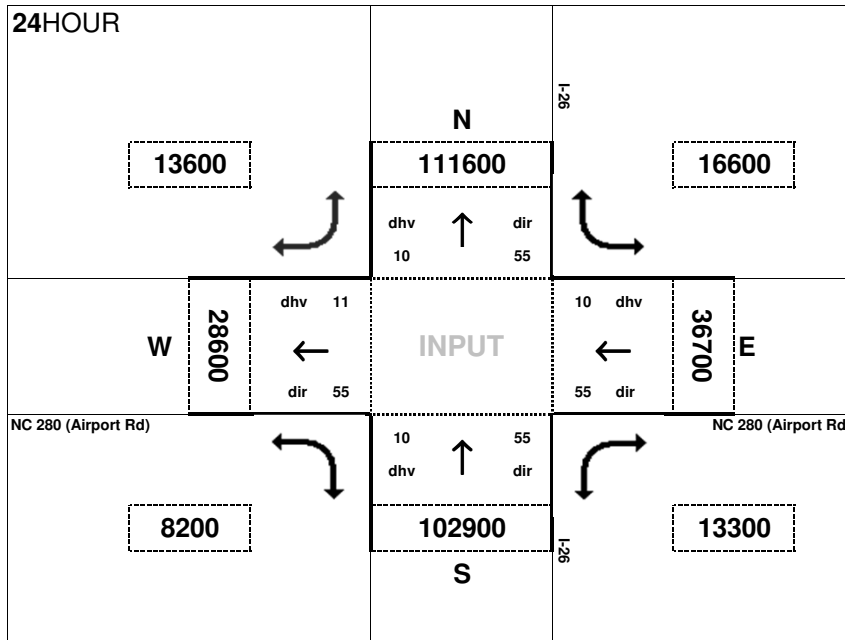

Peak Hour Volume Breakouts Report:
8. I-26 & NC 280 Interchange

Traffic Forecast Release Date:
February-12

Traffic Data Year:
2040 DY - Build 8 Ln

Project:
STIP I-4400/4700 - I-26 Widening

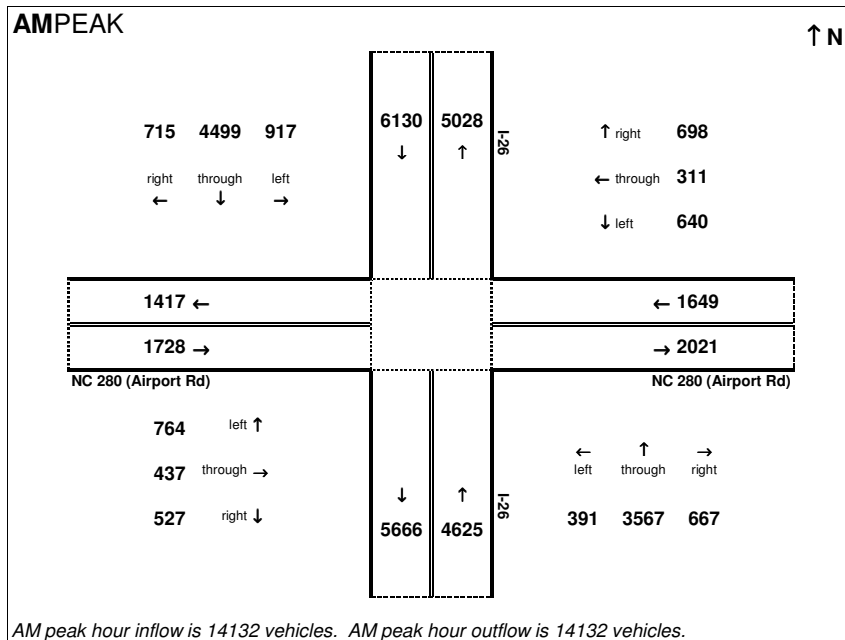

AM peak hour inflow is 14132 vehicles. AM peak hour outflow is 14132 vehicles.

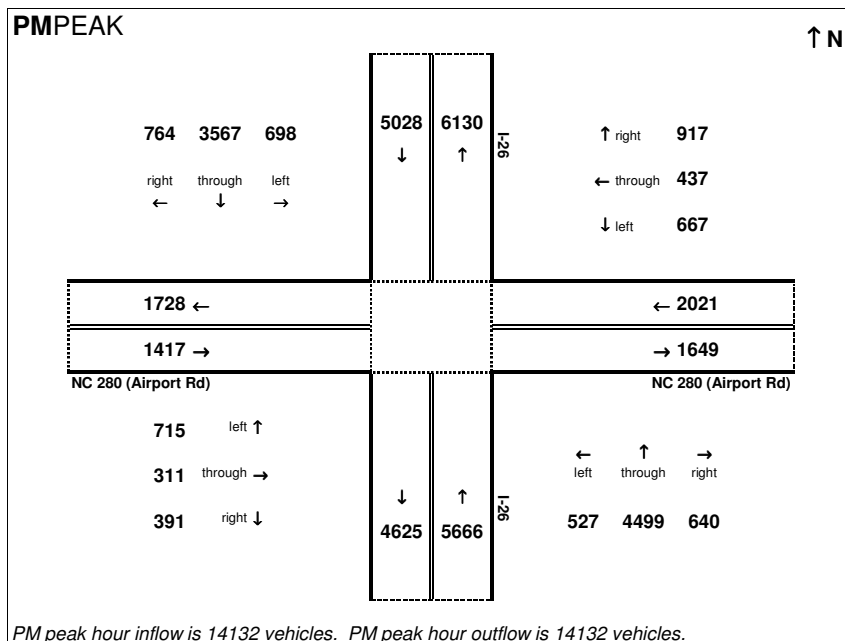

PM peak hour inflow is 14132 vehicles. PM peak hour outflow is 14132 vehicles.

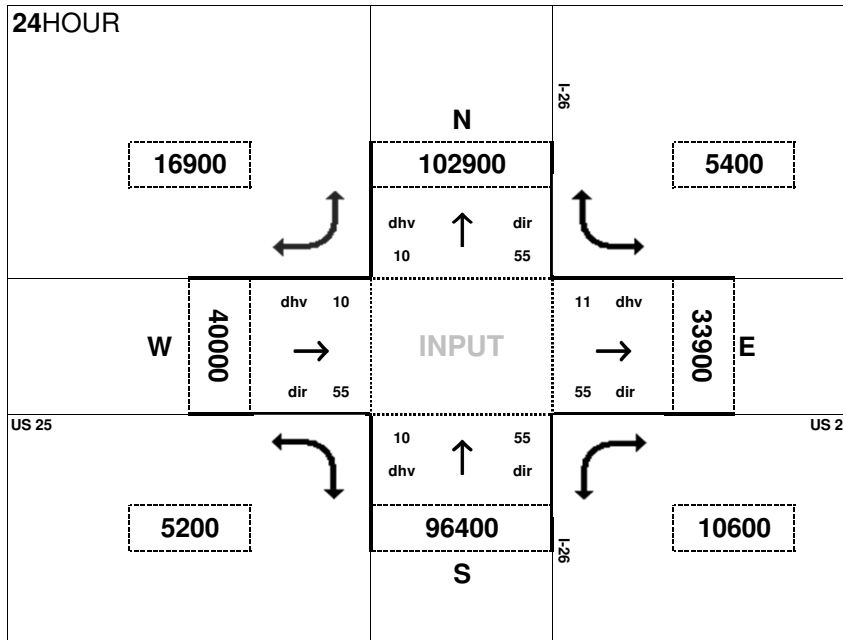

Peak Hour Volume Breakouts Report:
10. I-26 & US 25 Interchange

Traffic Forecast Release Date:
February-12

Traffic Data Year:
2040 DY - Build 8 Ln

Project:
STIP I-4400/4700 - I-26 Widening

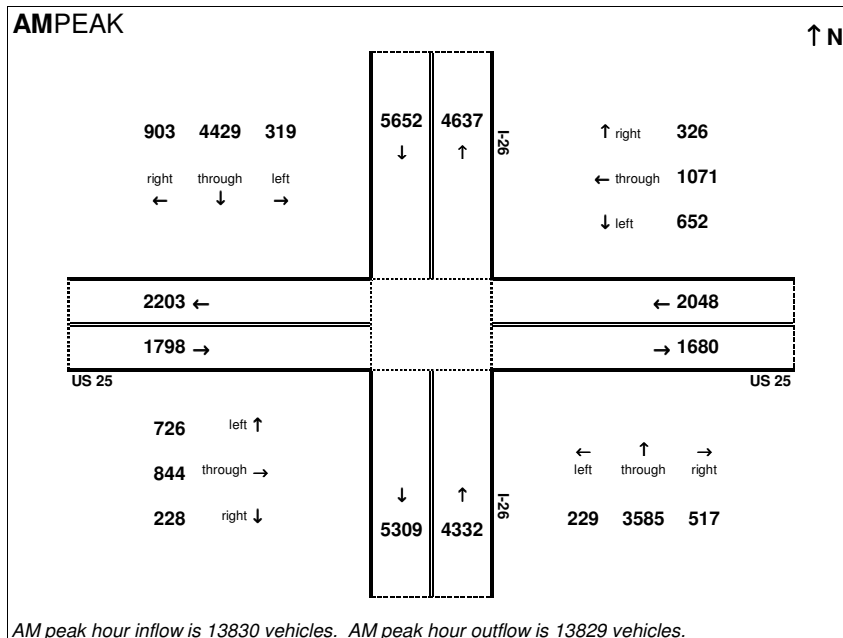

AM peak hour inflow is 13830 vehicles. AM peak hour outflow is 13829 vehicles.

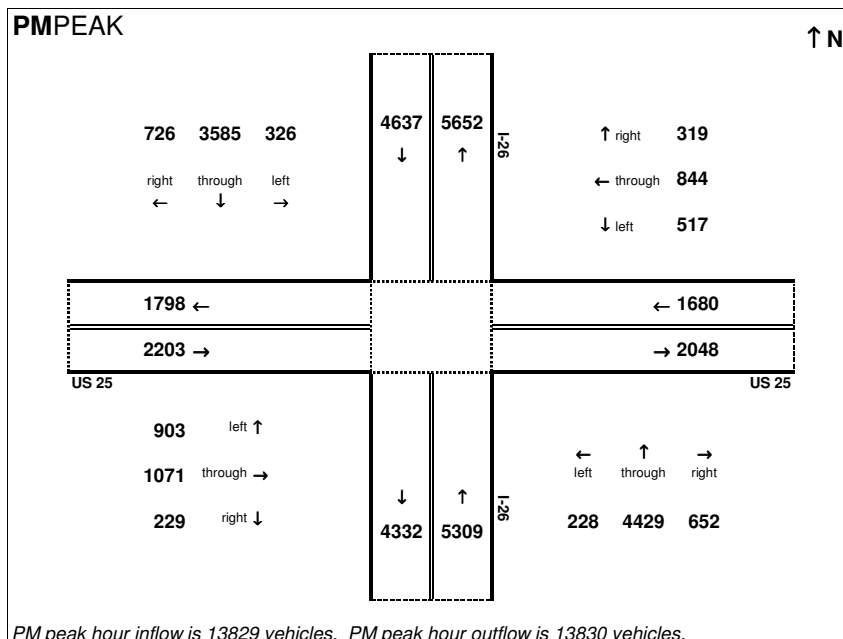

PM peak hour inflow is 13829 vehicles. PM peak hour outflow is 13830 vehicles.

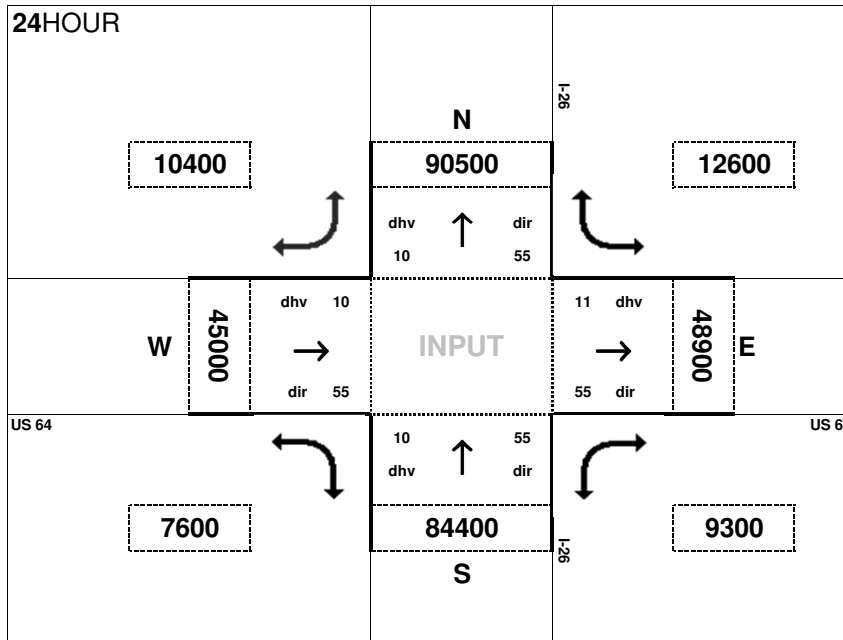

Peak Hour Volume Breakouts Report:
12. I-26 & US 64 System Interchange

Traffic Forecast Release Date:
February-12

Traffic Data Year:
2040 DY - Build 8 Ln

Project:
STIP I-4400/4700 - I-26 Widening

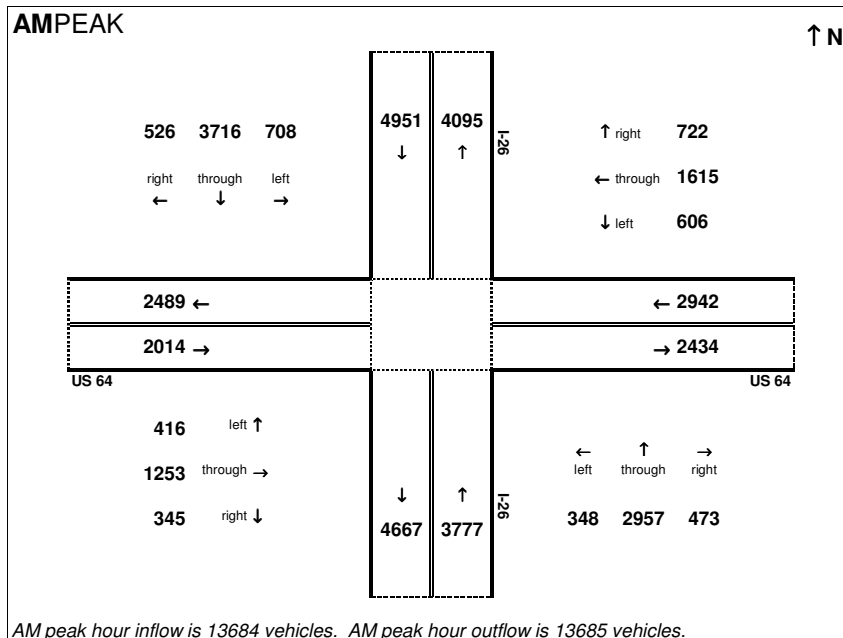

AM peak hour inflow is 13684 vehicles. AM peak hour outflow is 13685 vehicles.

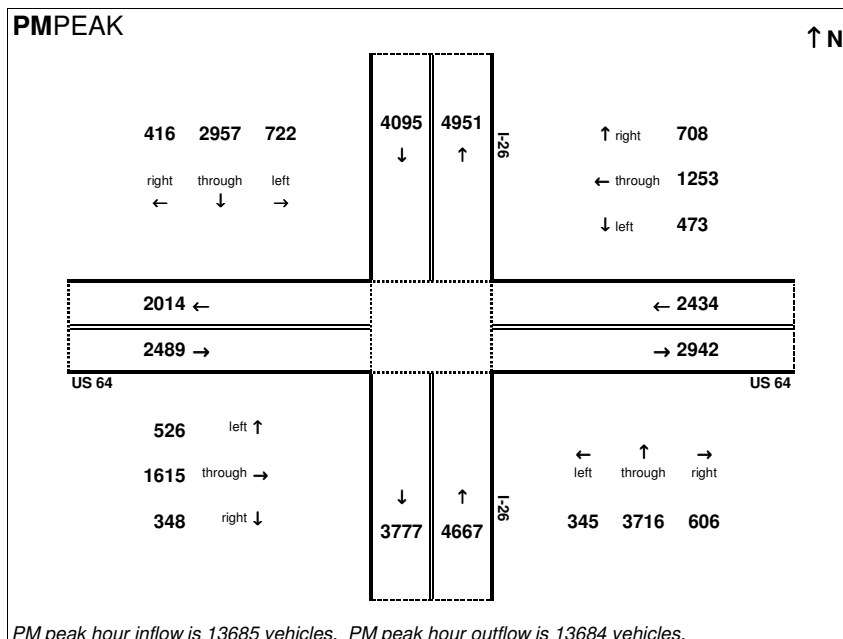

PM peak hour inflow is 13685 vehicles. PM peak hour outflow is 13684 vehicles.

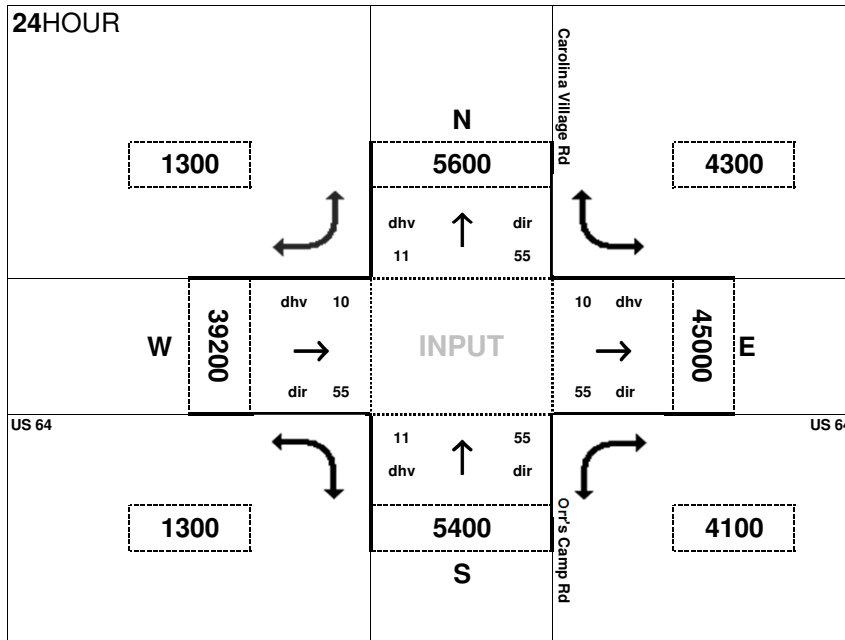

Peak Hour Volume Breakouts Report:

12a. US 64 & Carolina Village Rd / Orr's Camp Rd

Traffic Forecast Release Date:
February-12

Traffic Data Year:
2040 BY - 8 Lanes

Project:
STIP I-4400/4700 - I-26 Widening

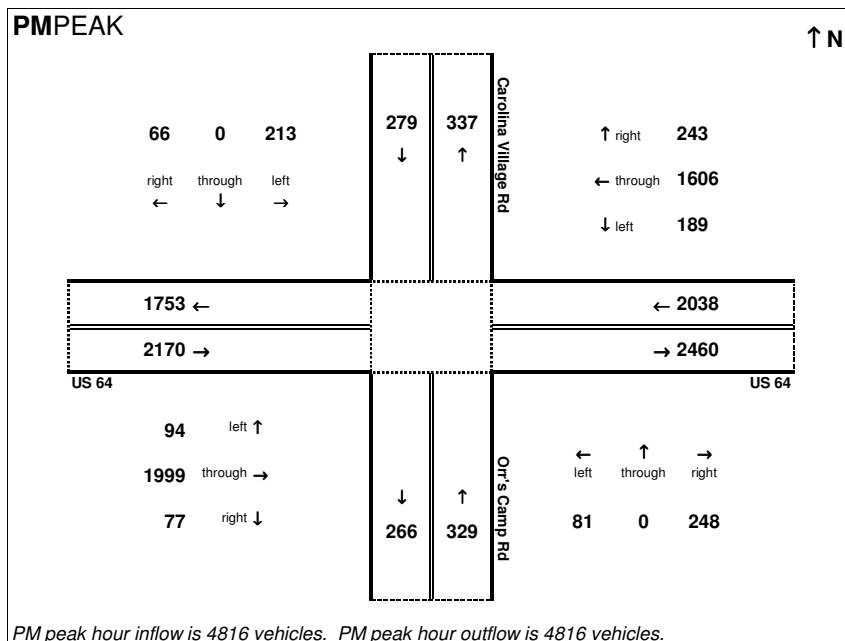
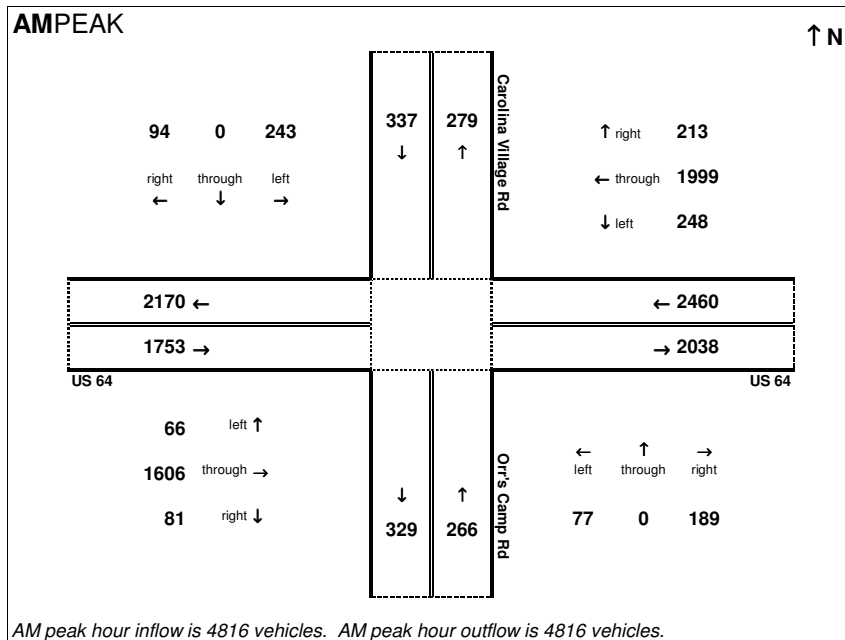

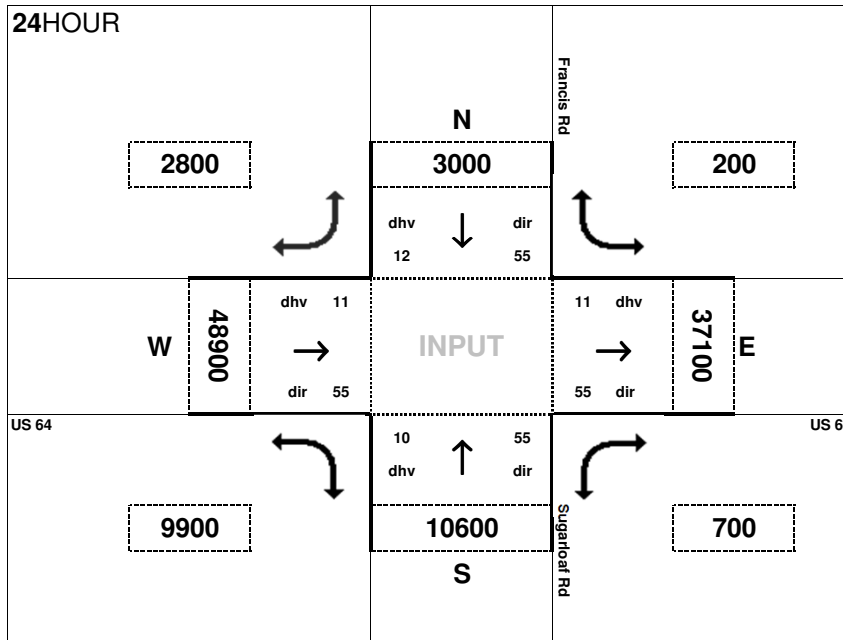

Peak Hour Volume Breakouts Report:
12b. US 64 & Francis Rd / Sugarloaf Rd

Traffic Forecast Release Date:
February-12

Traffic Data Year:
2040 BY - 8 Lanes

Project:
STIP I-4400/4700 - I-26 Widening

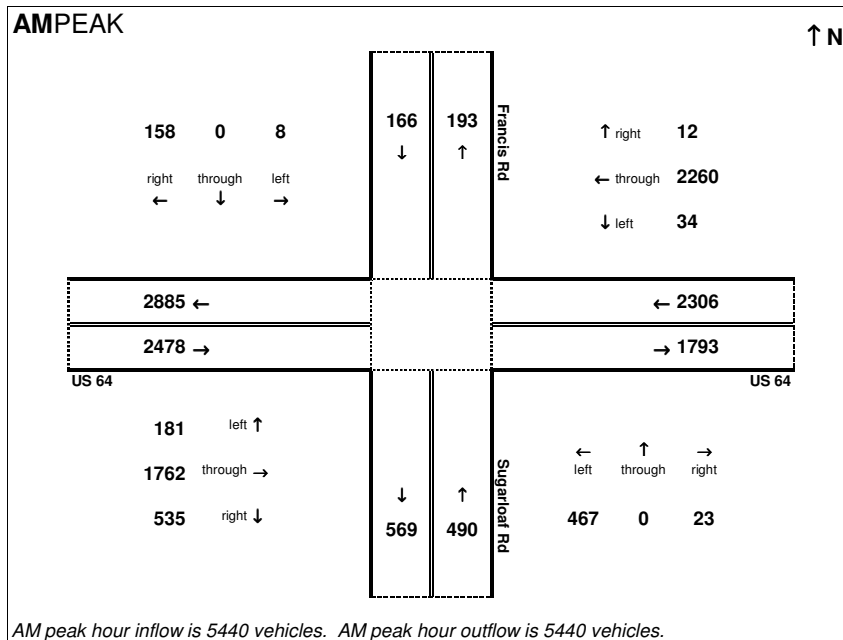

AM peak hour inflow is 5440 vehicles. AM peak hour outflow is 5440 vehicles.

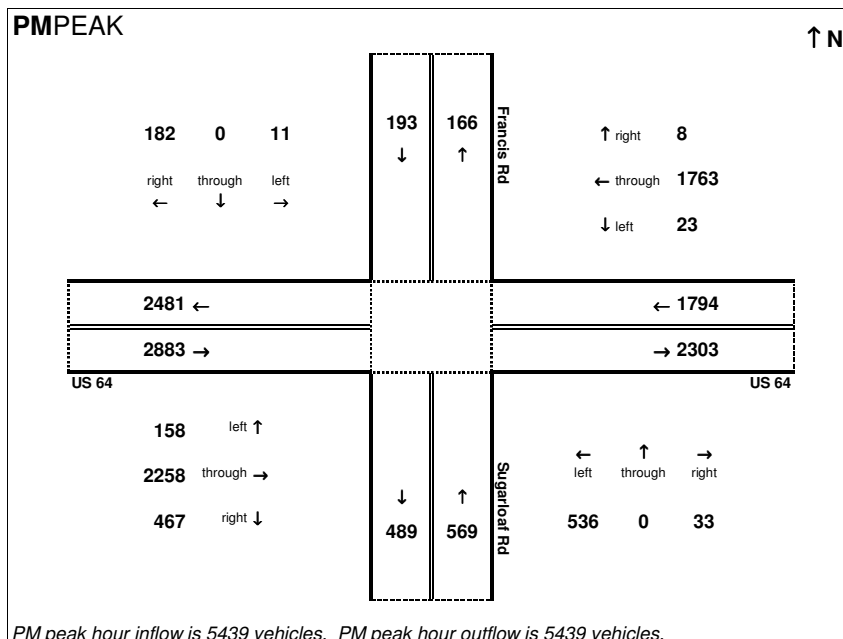

PM peak hour inflow is 5439 vehicles. PM peak hour outflow is 5439 vehicles.

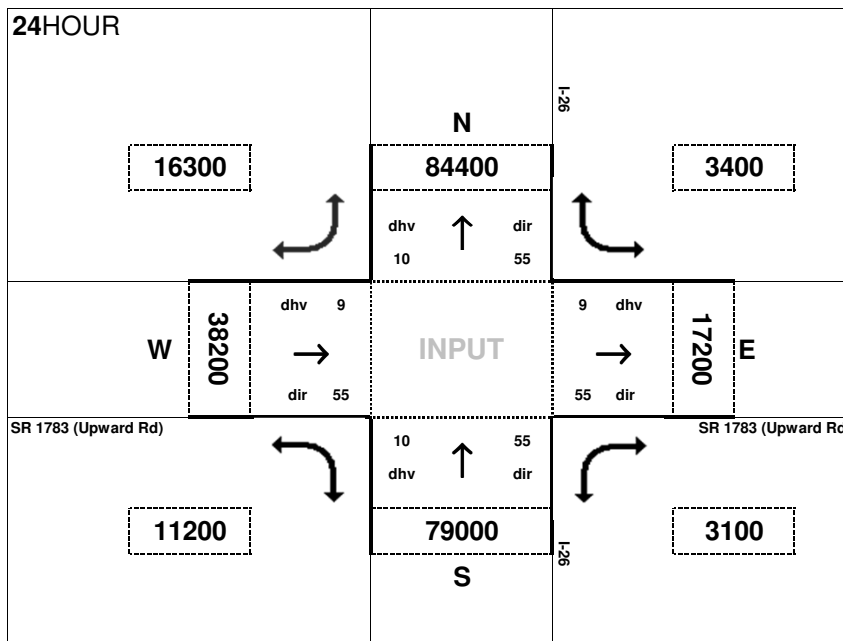

Peak Hour Volume Breakouts Report:
13. I-26 & Upward Road Interchange

Traffic Forecast Release Date:
February-12

Traffic Data Year:
2040 DY - Build 8 Ln

Project:
STIP I-4400/4700 - I-26 Widening

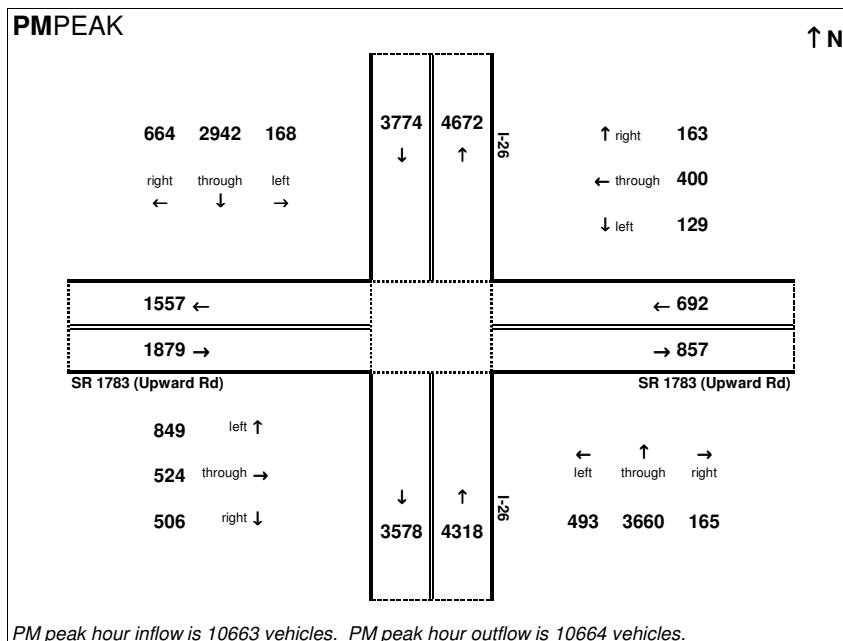
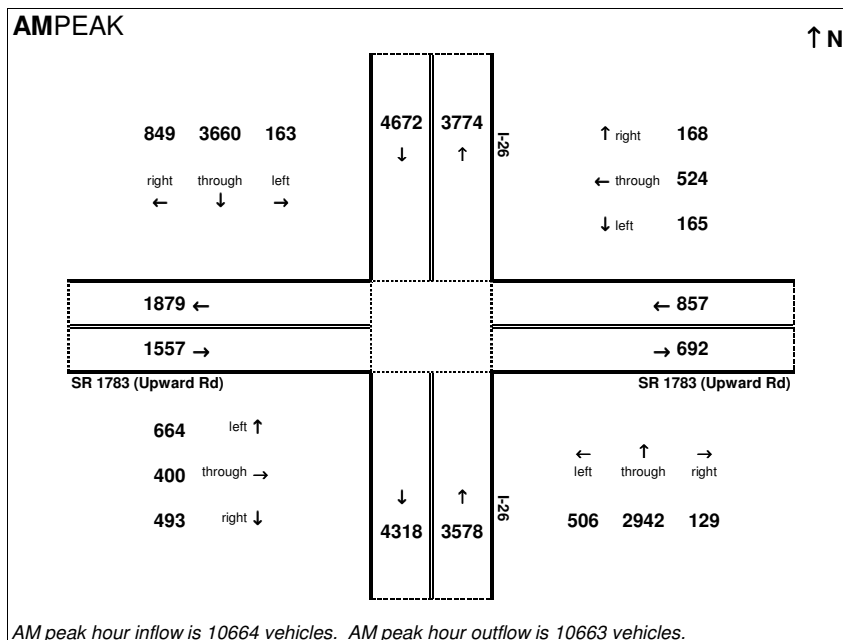

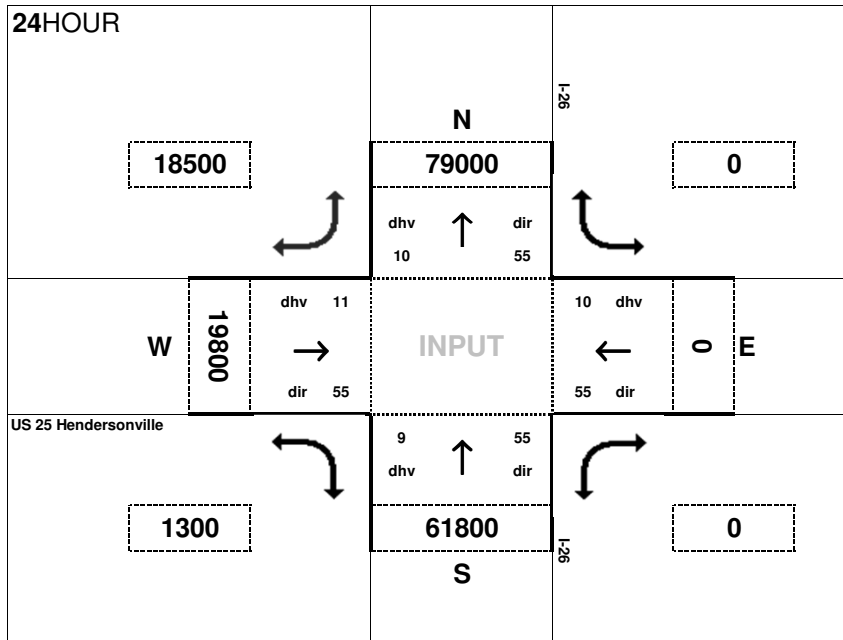

Peak Hour Volume Breakouts Report:
 14. I-26 & US 25 Hendersonville Interchange

Traffic Forecast Release Date:
 February-12

Traffic Data Year:
 2040 DY - Build 8 Ln

Project:
 STIP I-4400/4700 - I-26 Widening

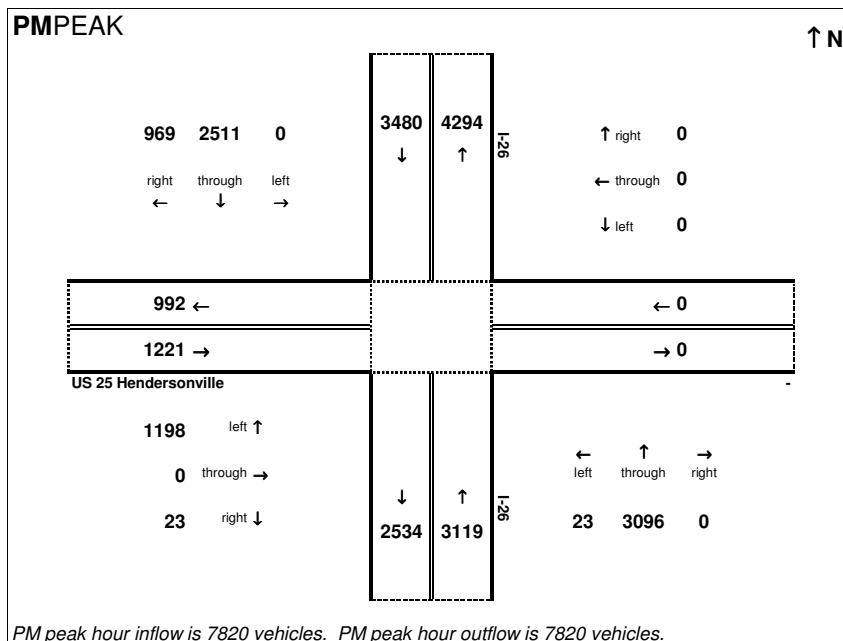
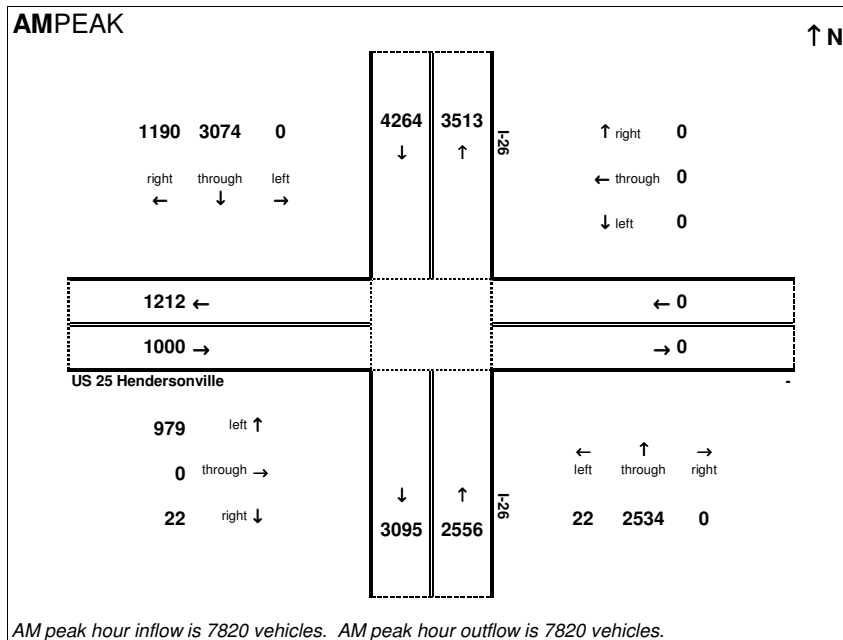

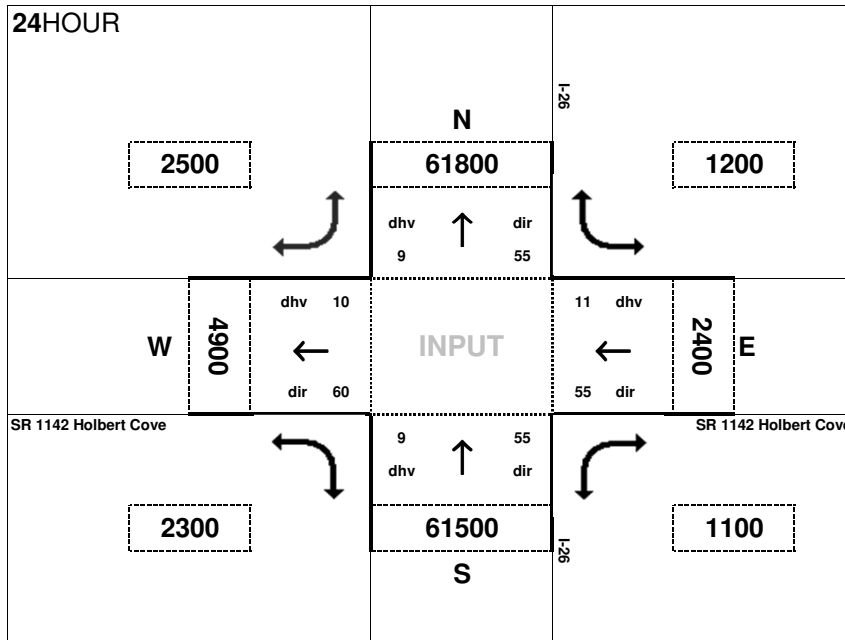

Peak Hour Volume Breakouts Report:
15. I-26 & Holbert Cove Rd Interchange

Traffic Forecast Release Date:
February-12

Traffic Data Year:
2040 DY - Build 8 Ln

Project:
STIP I-4400/4700 - I-26 Widening

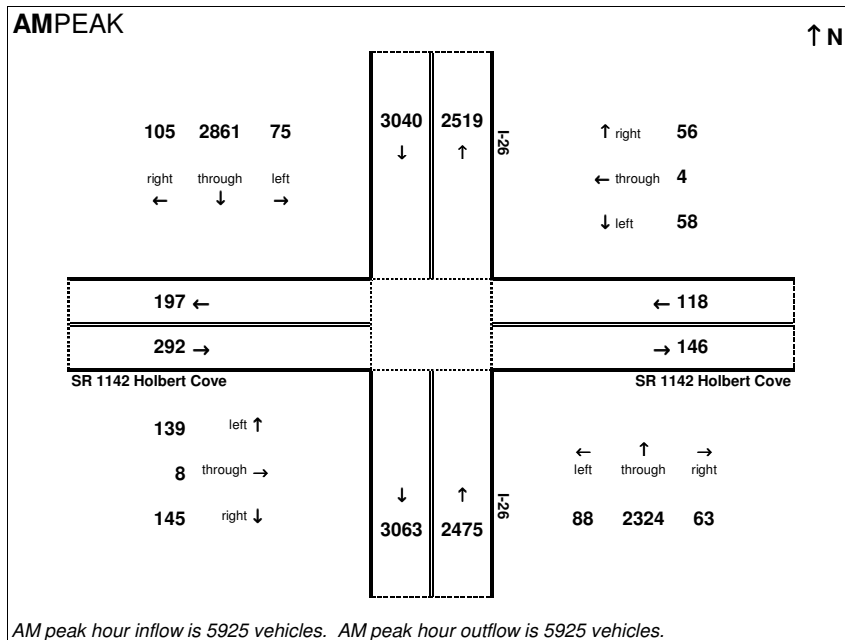

AM peak hour inflow is 5925 vehicles. AM peak hour outflow is 5925 vehicles.

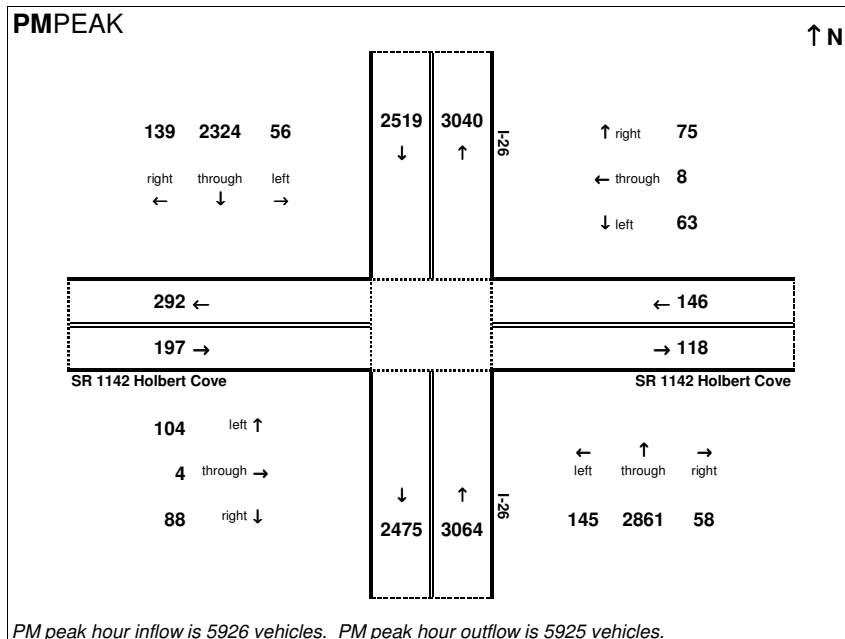

PM peak hour inflow is 5926 vehicles. PM peak hour outflow is 5925 vehicles.

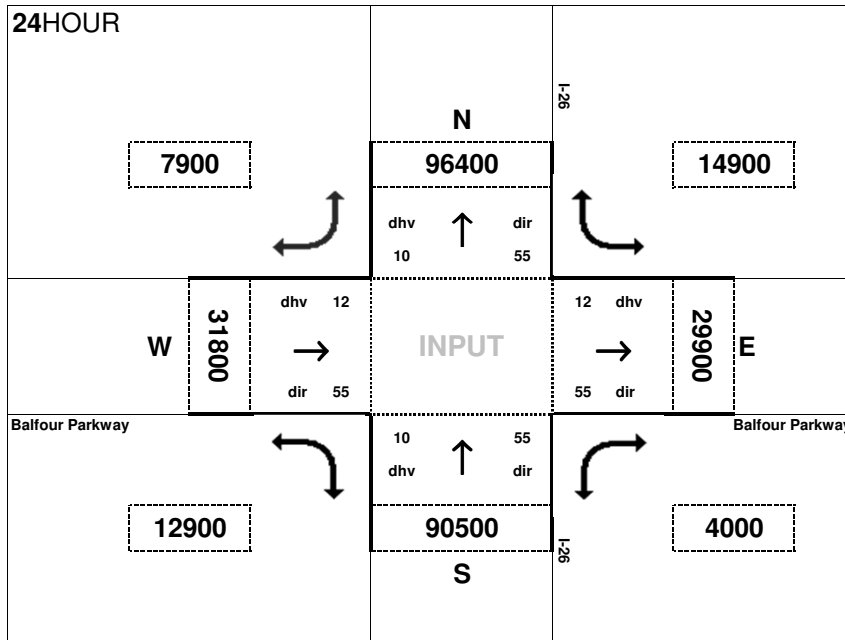

Peak Hour Volume Breakouts Report:

16. I-26 & Future Balfour Parkway Interchange

Traffic Forecast Release Date:
February-12

Traffic Data Year:
2040 DY - Build 8 Ln

Project:
STIP I-4400/4700 - I-26 Widening

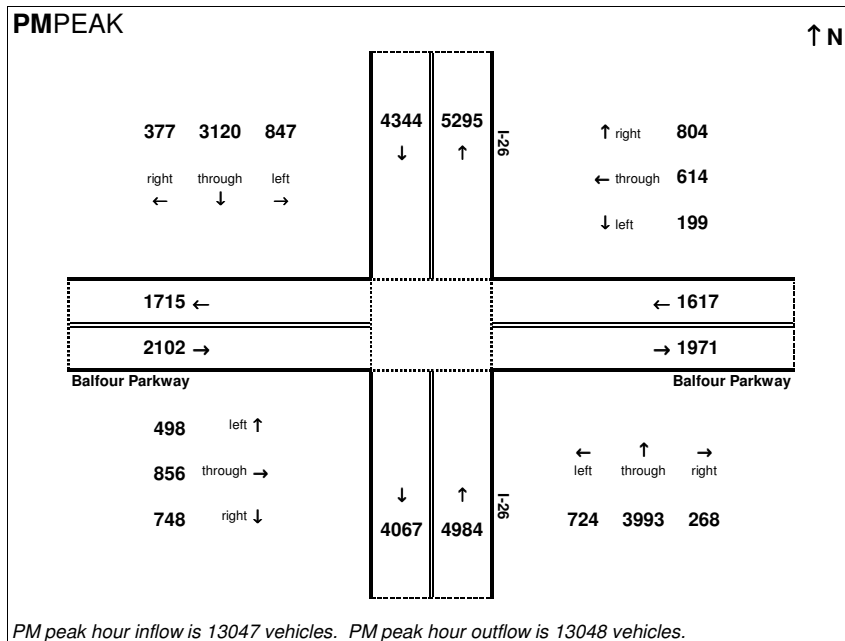
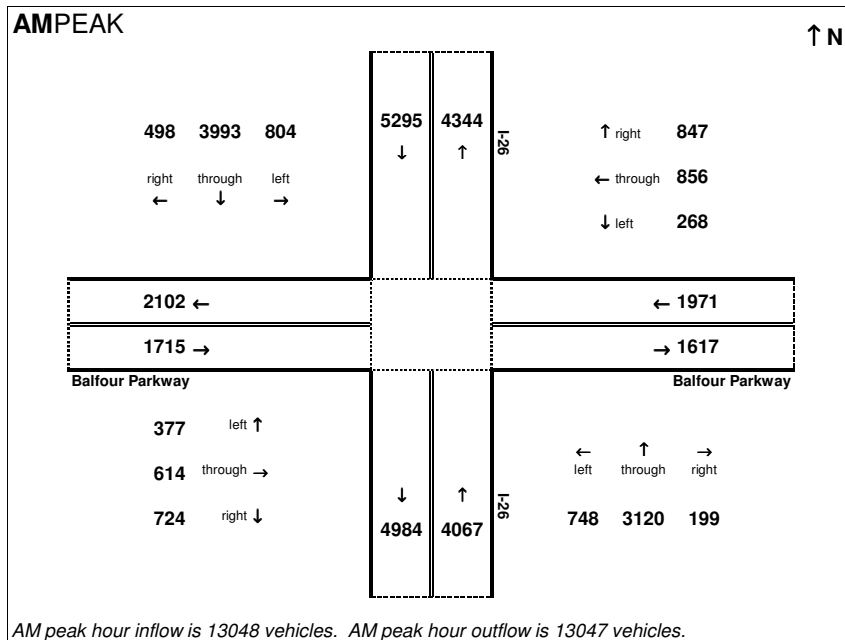

Project: I-4400/4700 I-26 Widening
 Scenario: No-Build
 Analysis Year: 2011 Base Year
 Date: 3/30/12
 Interchange: I-26 & NC 191 Brevard Road

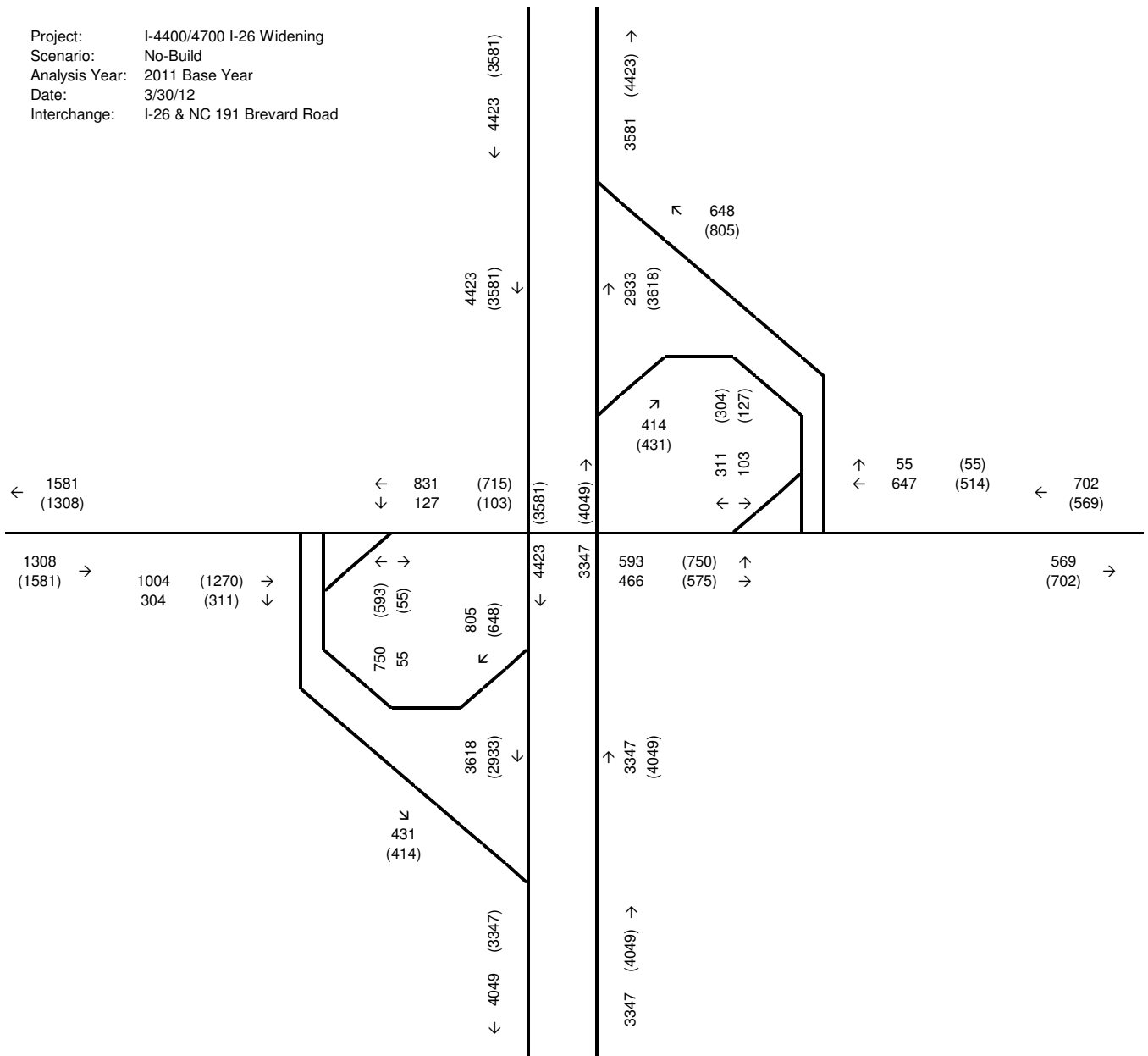

Project: I-4400/4700 I-26 Widening
 Scenario: Build - 6 Lane
 Analysis Year: 2011 Base Year
 Date: 3/30/12
 Interchange: I-26 & NC 191 Brevard Road

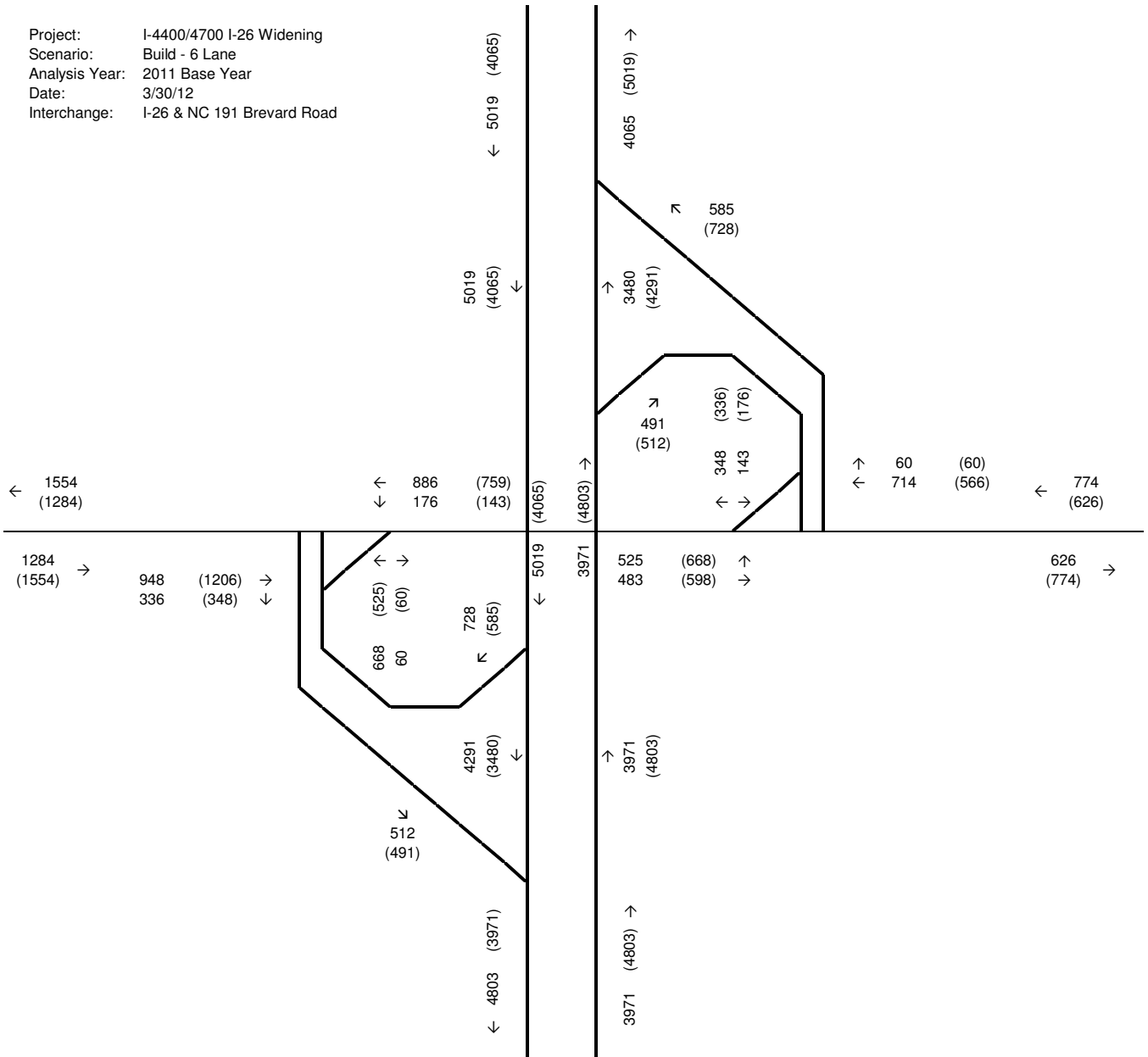

Project: I-4400/4700 I-26 Widening
 Scenario: Build - 8 Lane
 Analysis Year: 2011 Base Year
 Date: 3/30/12
 Interchange: I-26 & NC 191 Brevard Road

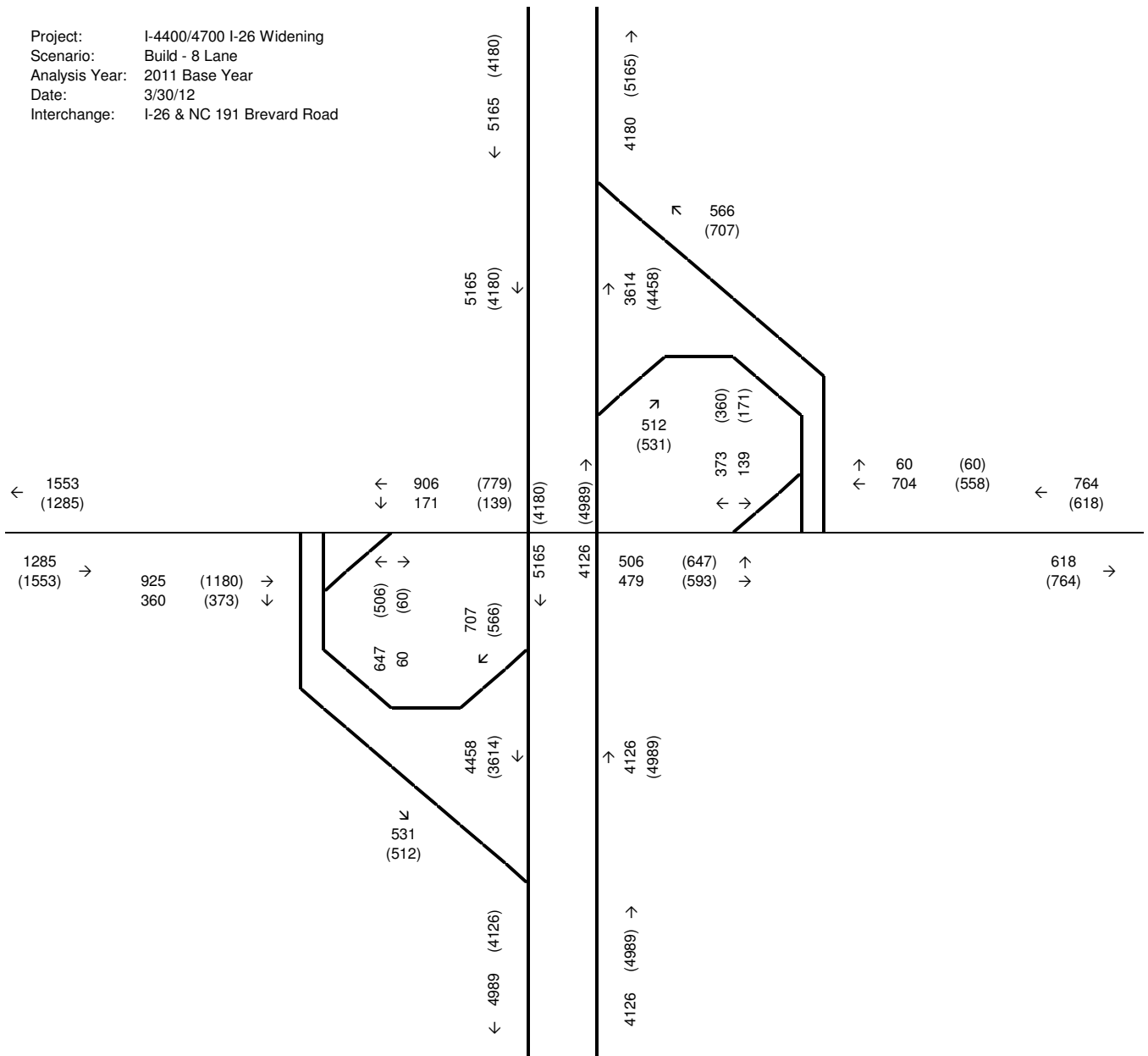

Project: I-4400/4700 I-26 Widening
 Scenario: No-Build
 Analysis Year: 2040 Design Year
 Date: 3/30/12
 Interchange: I-26 & NC 191 Brevard Road

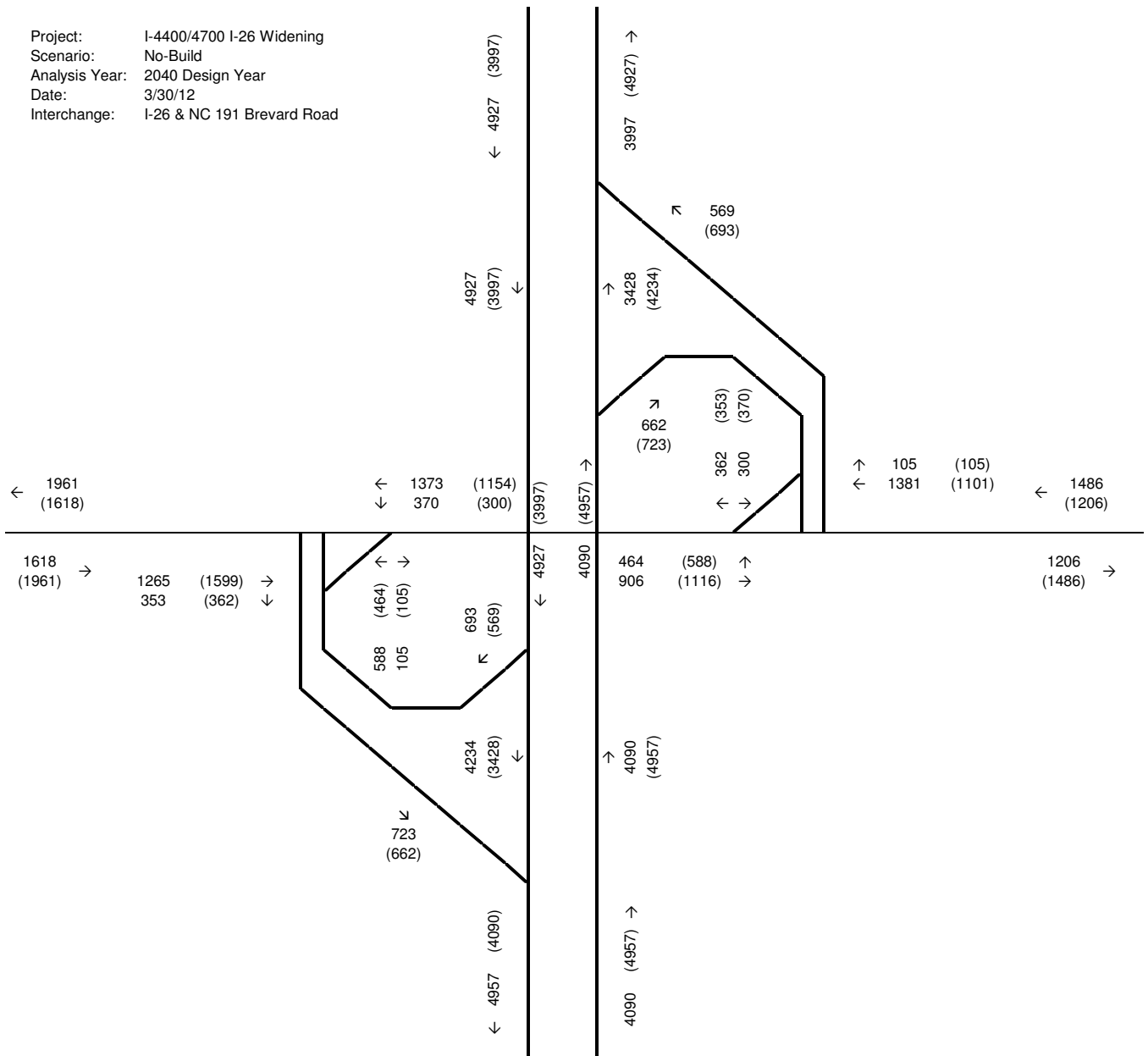

Project: I-4400/4700 I-26 Widening
 Scenario: Build - 6 Lane
 Analysis Year: 2040 Design Year
 Date: 3/30/12
 Interchange: I-26 & NC 191 Brevard Road

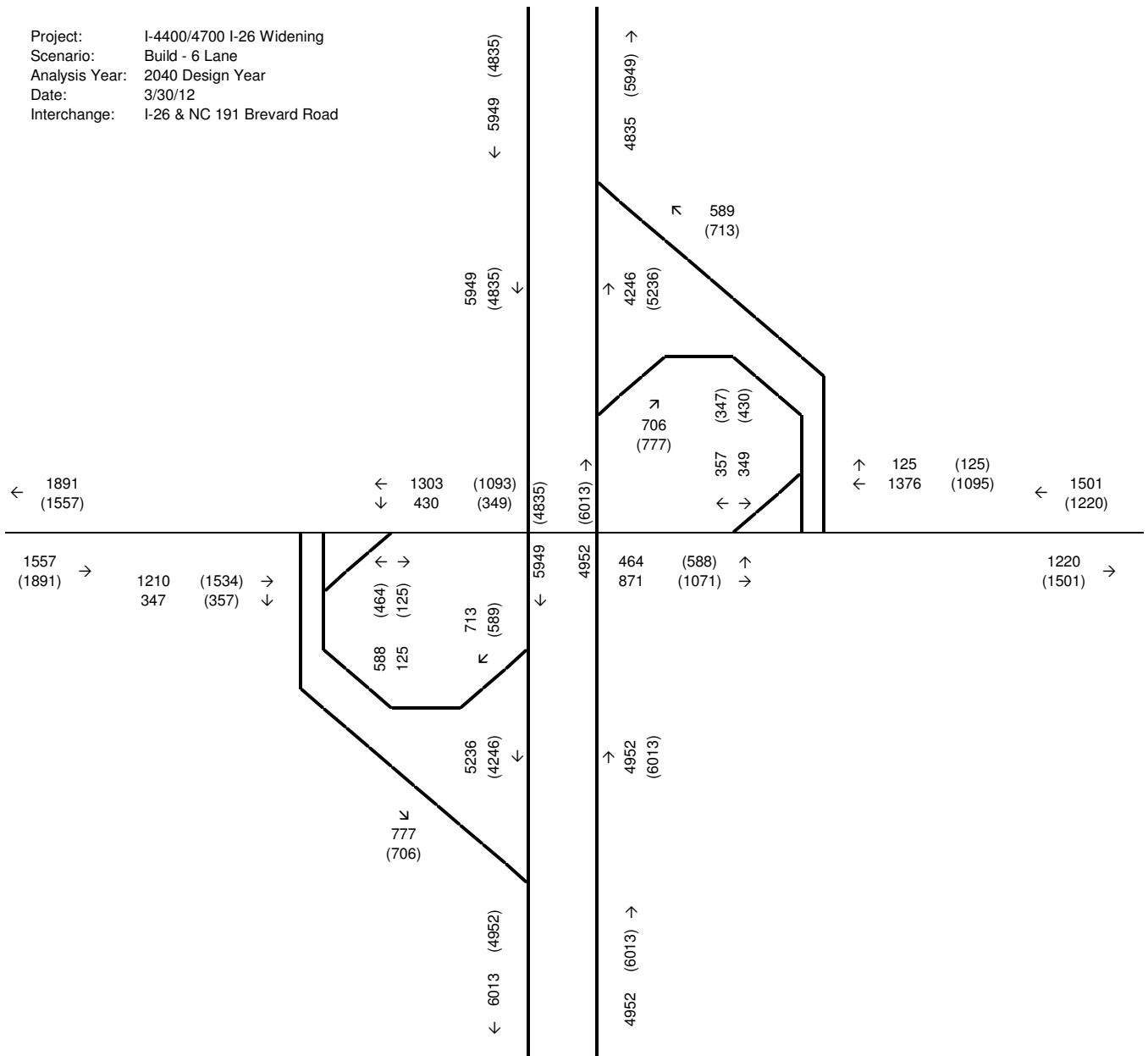

Project: I-4400/4700 I-26 Widening
 Scenario: Build - 8 Lane
 Analysis Year: 2040 Design Year
 Date: 3/30/12
 Interchange: I-26 & NC 191 Brevard Road

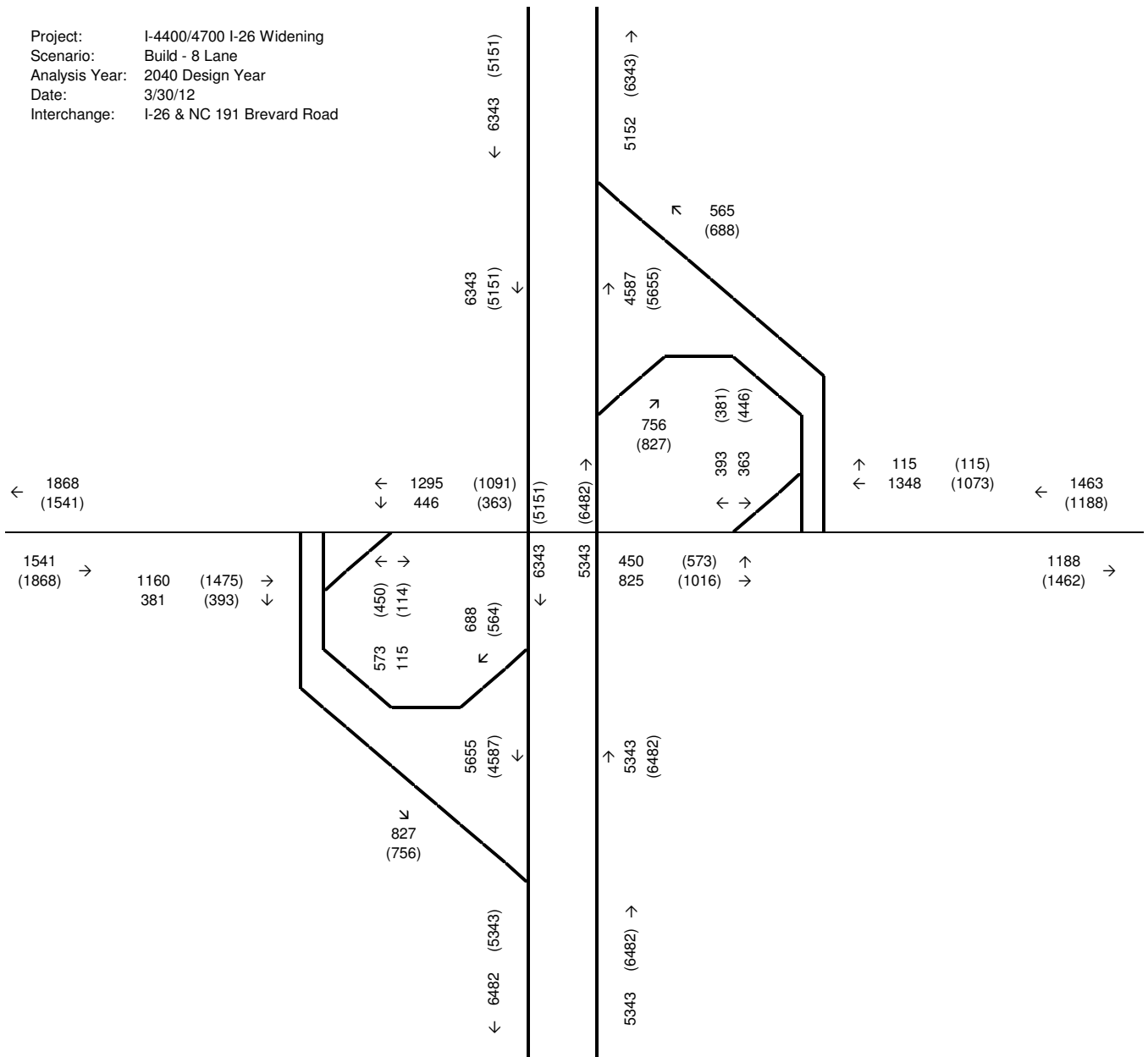

Project: I-4400/4700 I-26 Widening
 Scenario: No-Build
 Analysis Year: 2011 Base Year
 Date: 3/30/12
 Interchange: I-26 & NC 146 Long Shoals

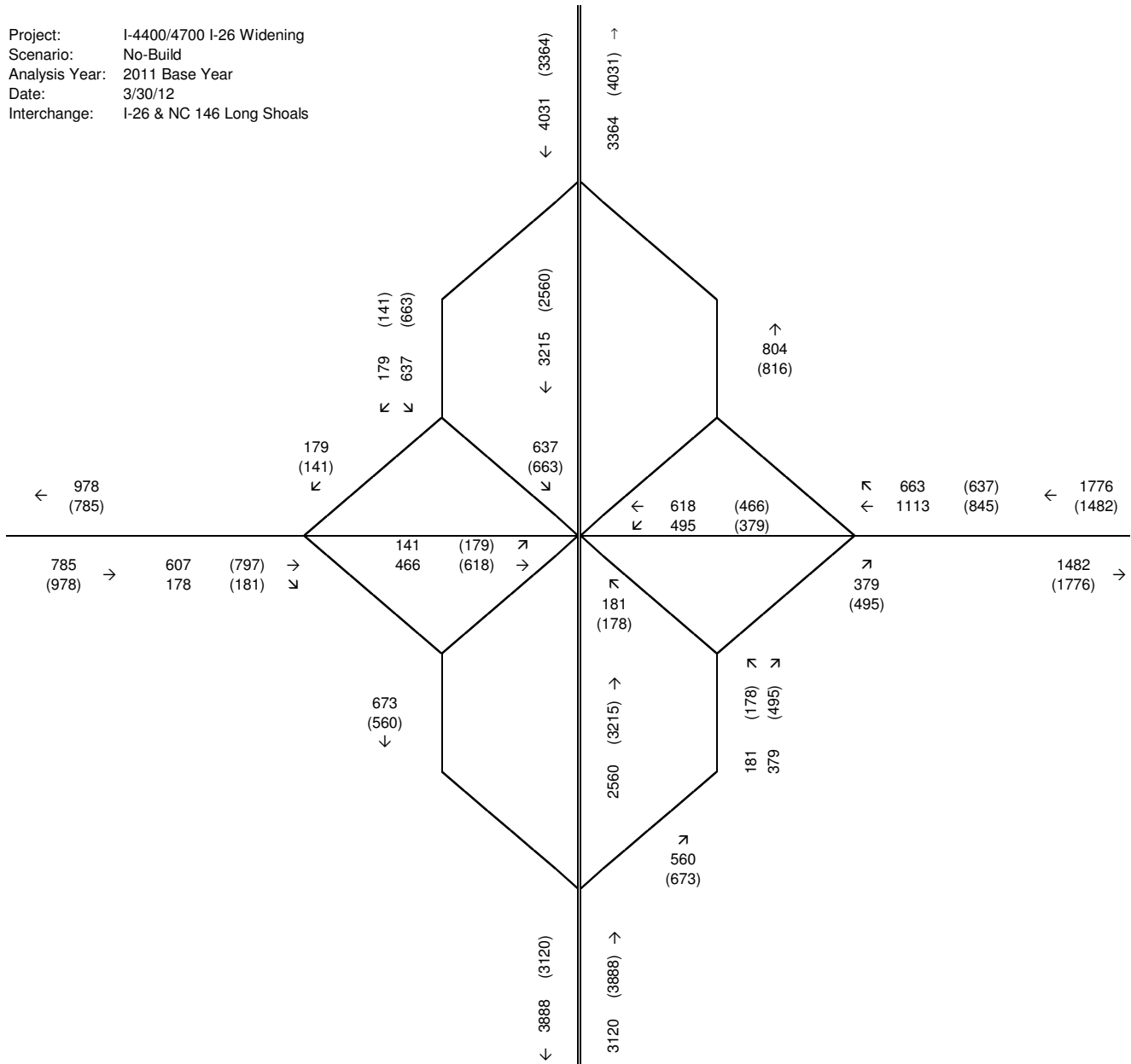

Project: I-4400/4700 I-26 Widening
 Scenario: Build - 6 Lane
 Analysis Year: 2011 Base Year
 Date: 3/30/12
 Interchange: I-26 & NC 146 Long Shoals

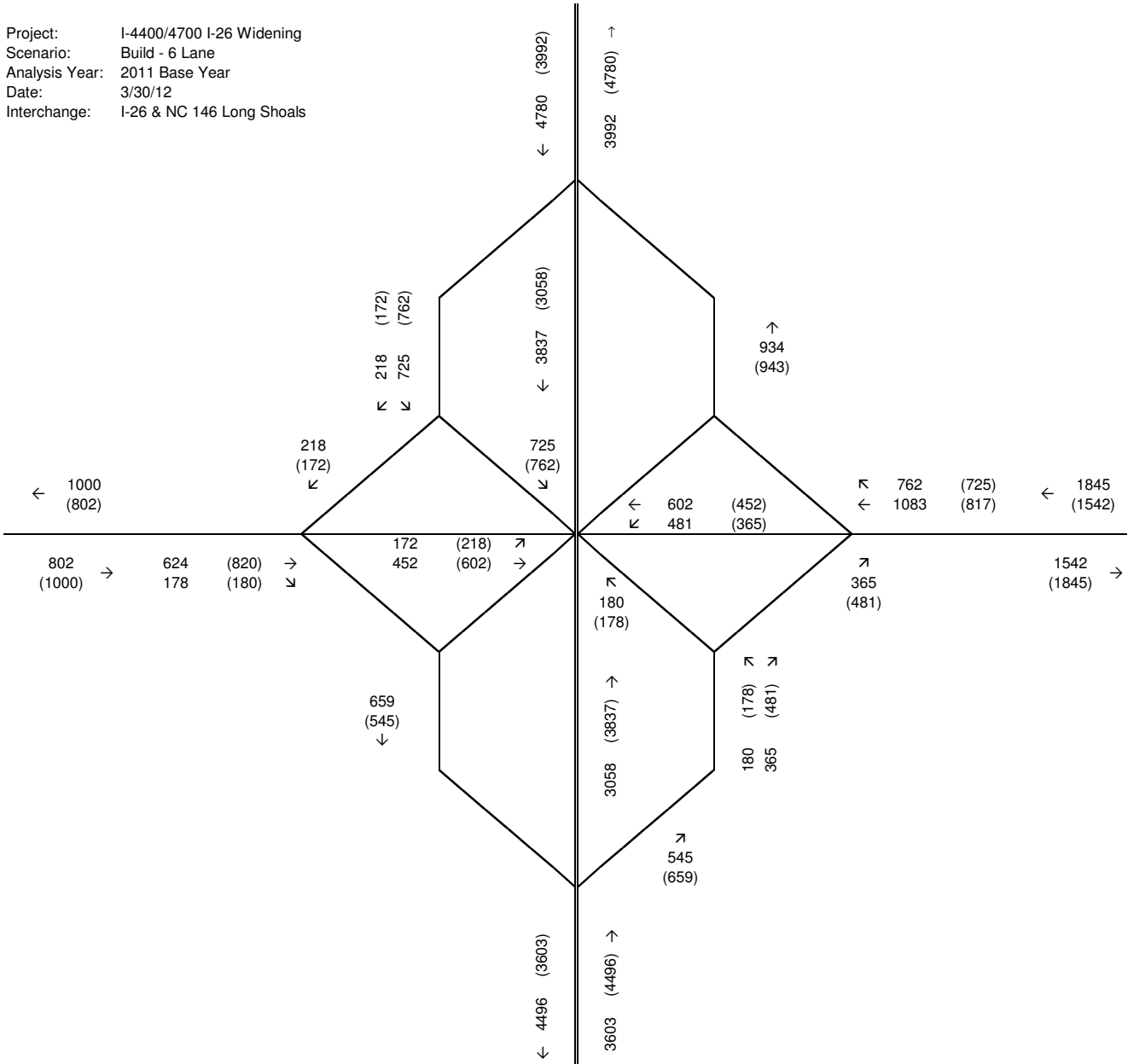

Project: I-4400/4700 I-26 Widening
 Scenario: Build - 8 Lane
 Analysis Year: 2011 Base Year
 Date: 3/30/12
 Interchange: I-26 & NC 146 Long Shoals

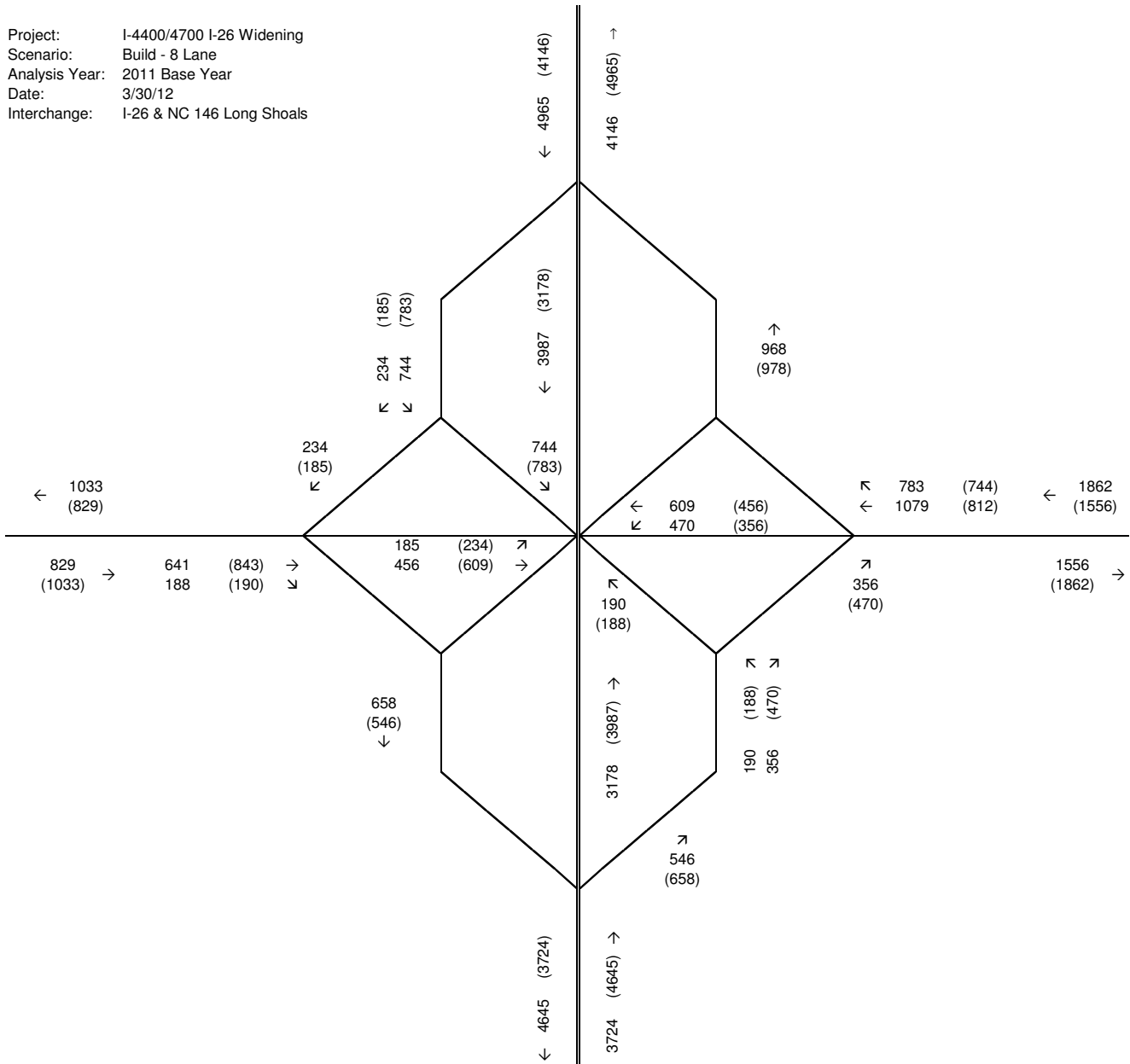

Project: I-4400/4700 I-26 Widening
 Scenario: No-Build
 Analysis Year: 2040 Design Year
 Date: 3/30/12
 Interchange: I-26 & NC 146 Long Shoals

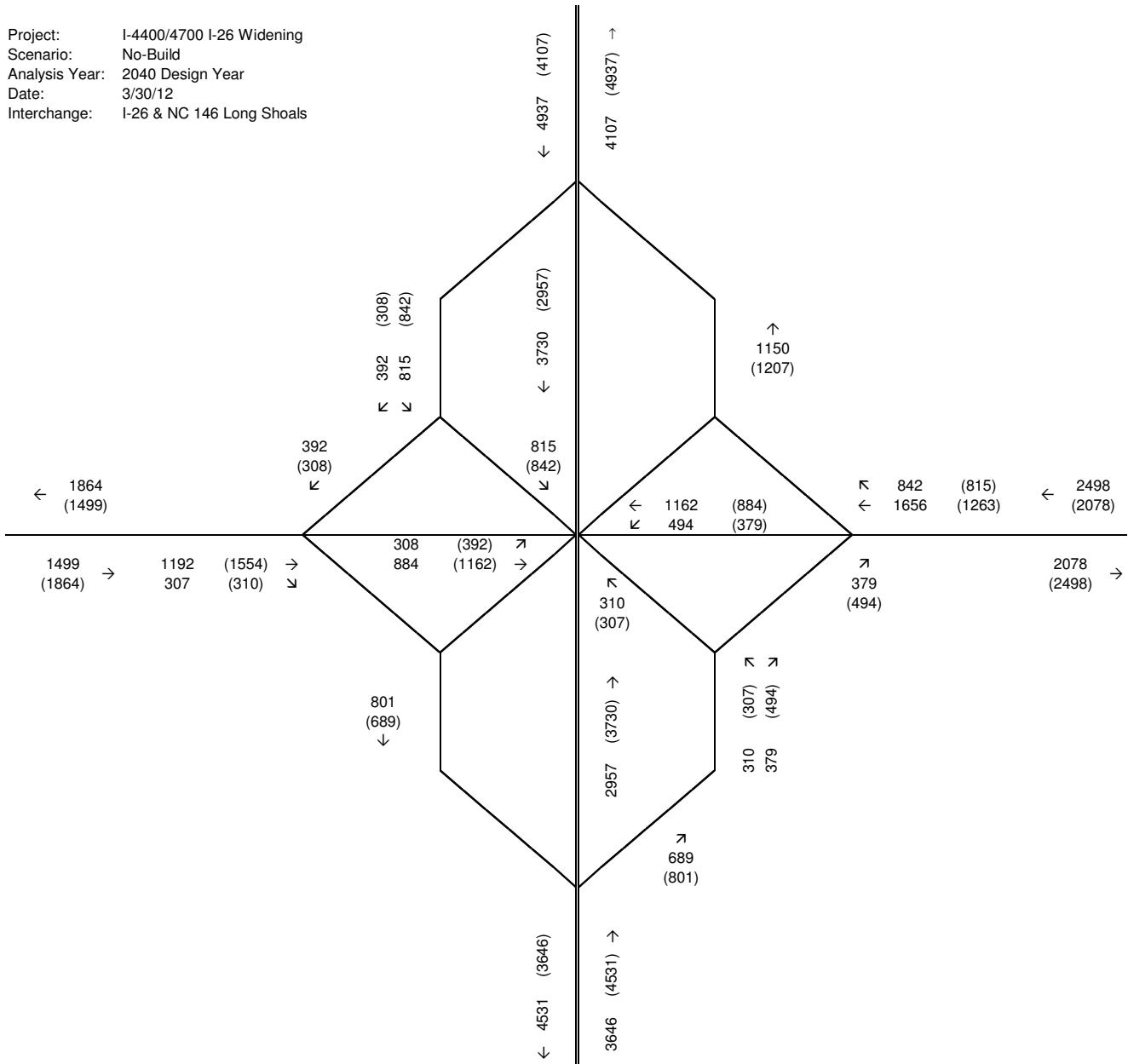

Project: I-4400/4700 I-26 Widening
 Scenario: Build - 6 Lane
 Analysis Year: 2040 Design Year
 Date: 3/30/12
 Interchange: I-26 & NC 146 Long Shoals

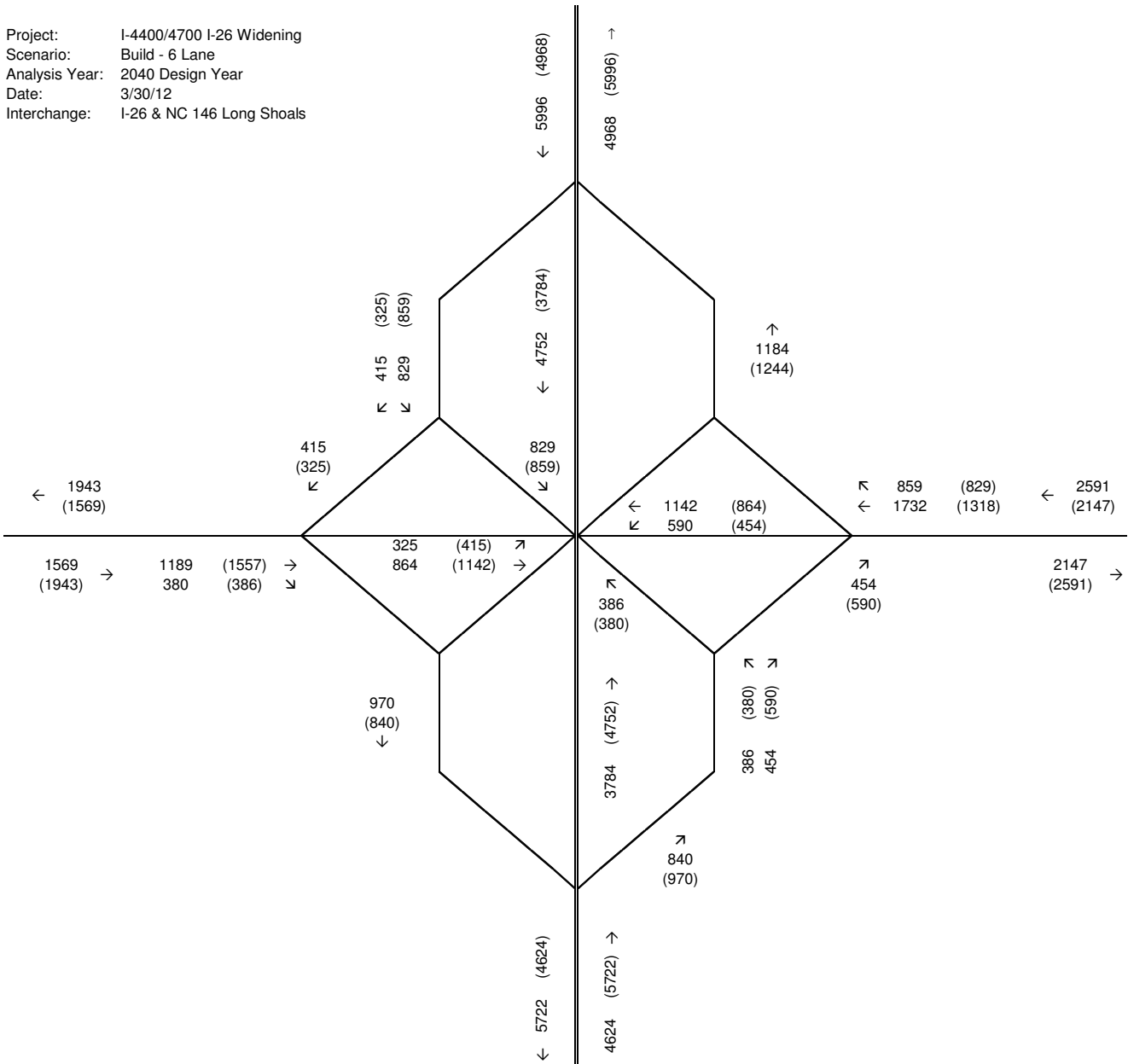

Project: I-4400/4700 I-26 Widening
 Scenario: Build - 8 Lane
 Analysis Year: 2040 Design Year
 Date: 3/30/12
 Interchange: I-26 & NC 146 Long Shoals

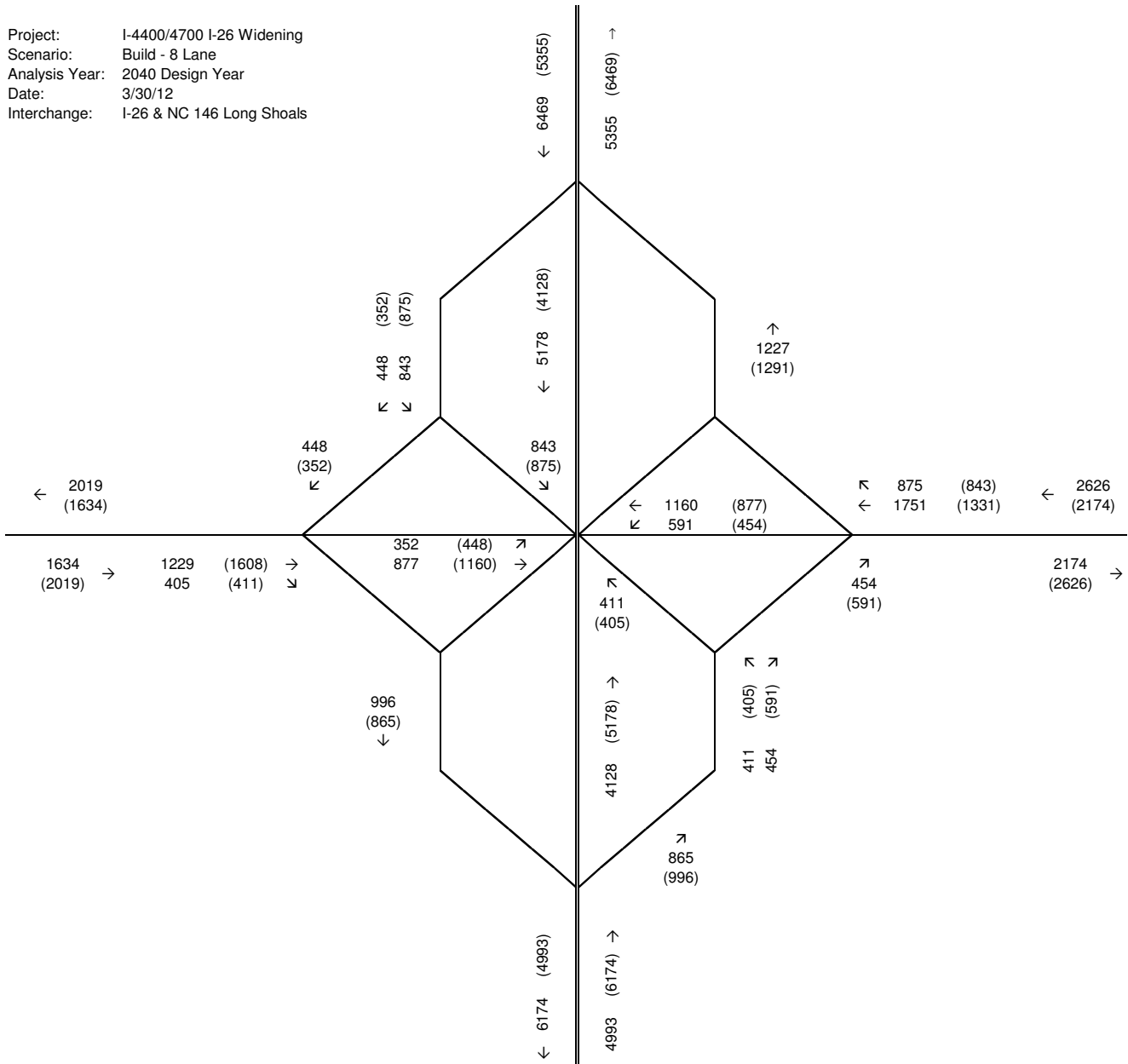

Project: I-4400/4700 I-26 Widening
 Scenario: No-Build
 Analysis Year: 2011 Base Year
 Date: 4/2/12
 Interchange: I-26 & NC 280 (Airport Rd)

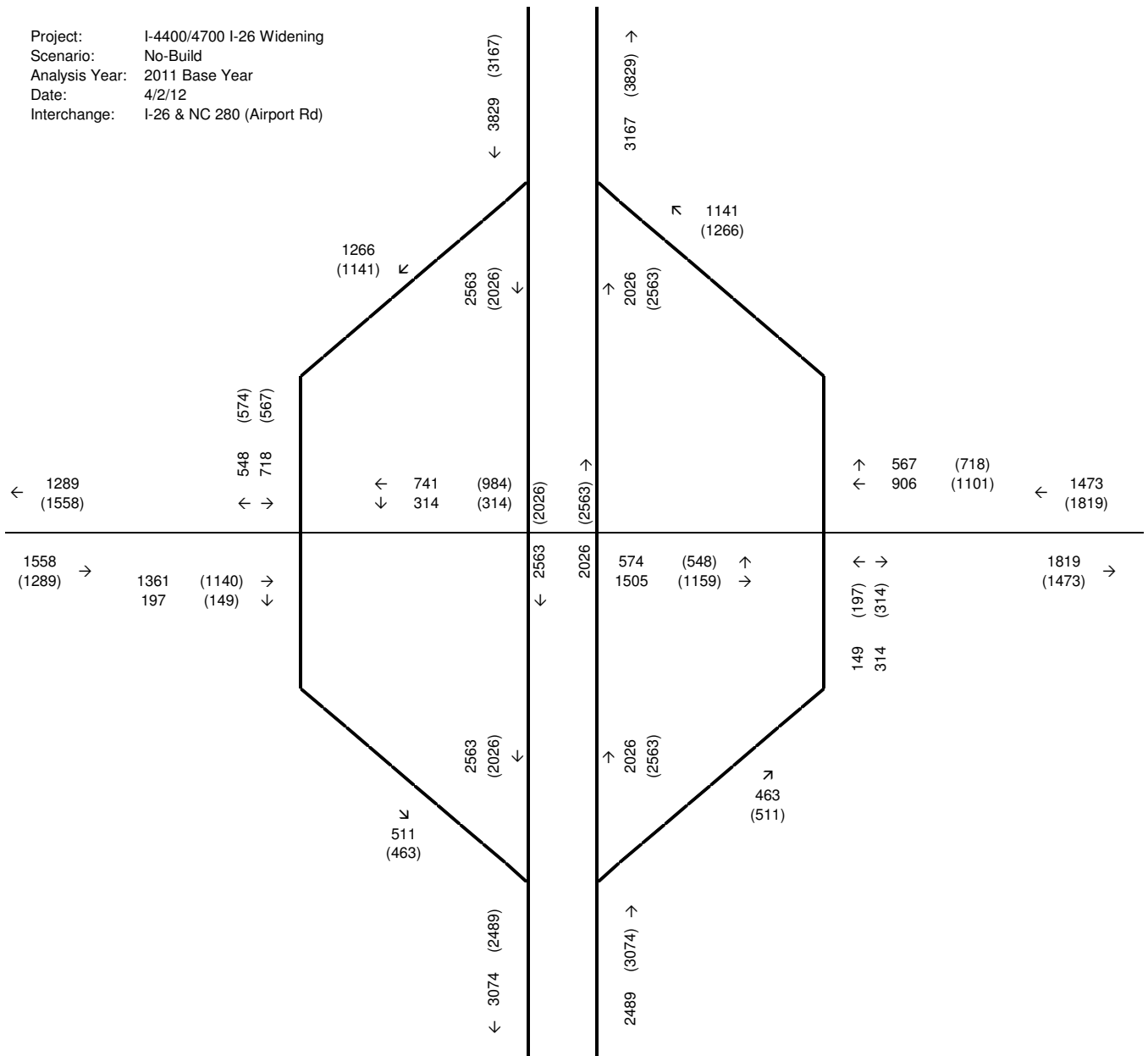

Project: I-4400/4700 I-26 Widening
 Scenario: Build - 6 Lane
 Analysis Year: 2011 Base Year
 Date: 4/2/12
 Interchange: I-26 & NC 280 (Airport Rd)

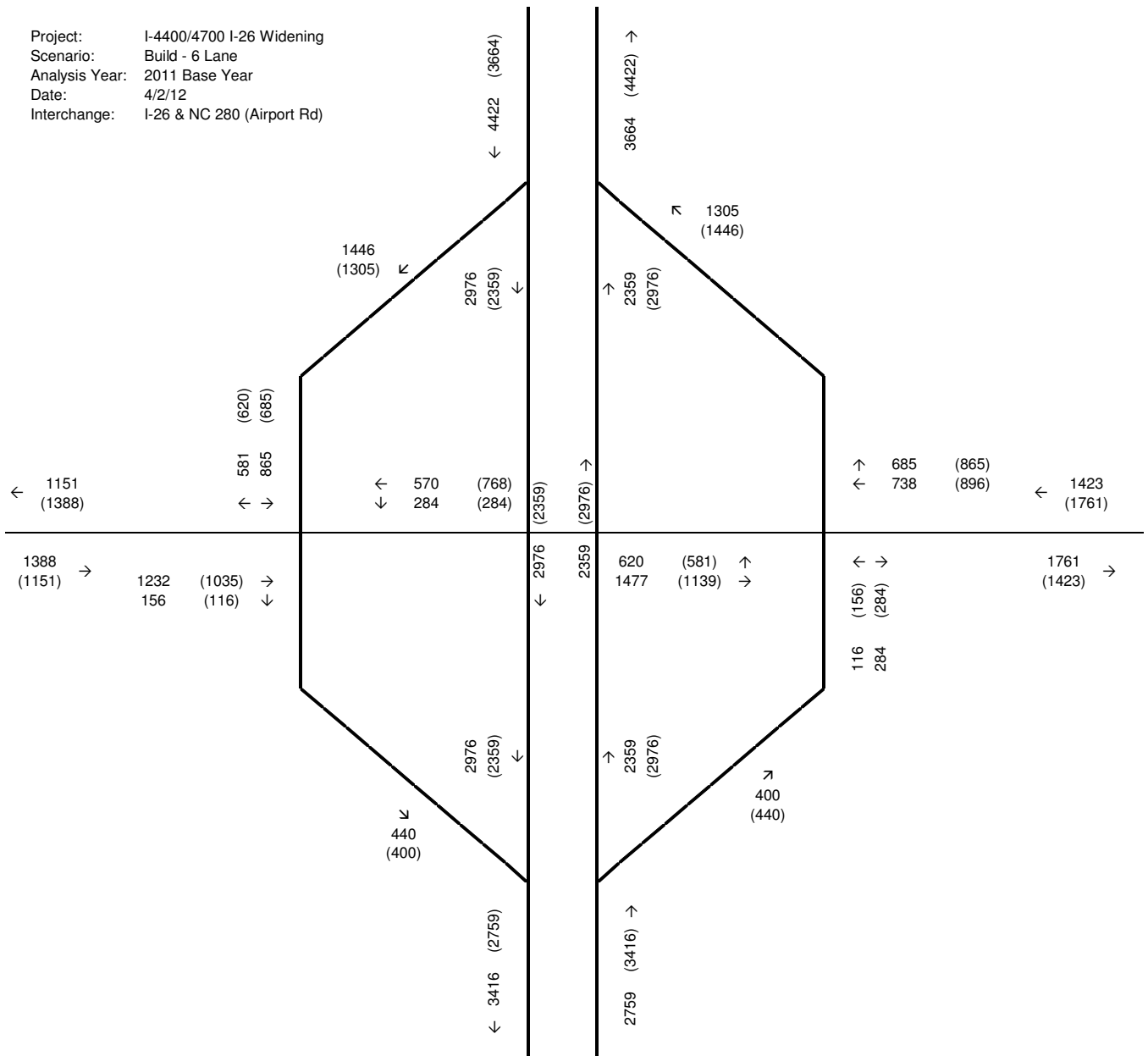

Project: I-4400/4700 I-26 Widening
 Scenario: Build - 8 Lane
 Analysis Year: 2011 Base Year
 Date: 4/2/12
 Interchange: I-26 & NC 280 (Airport Rd)

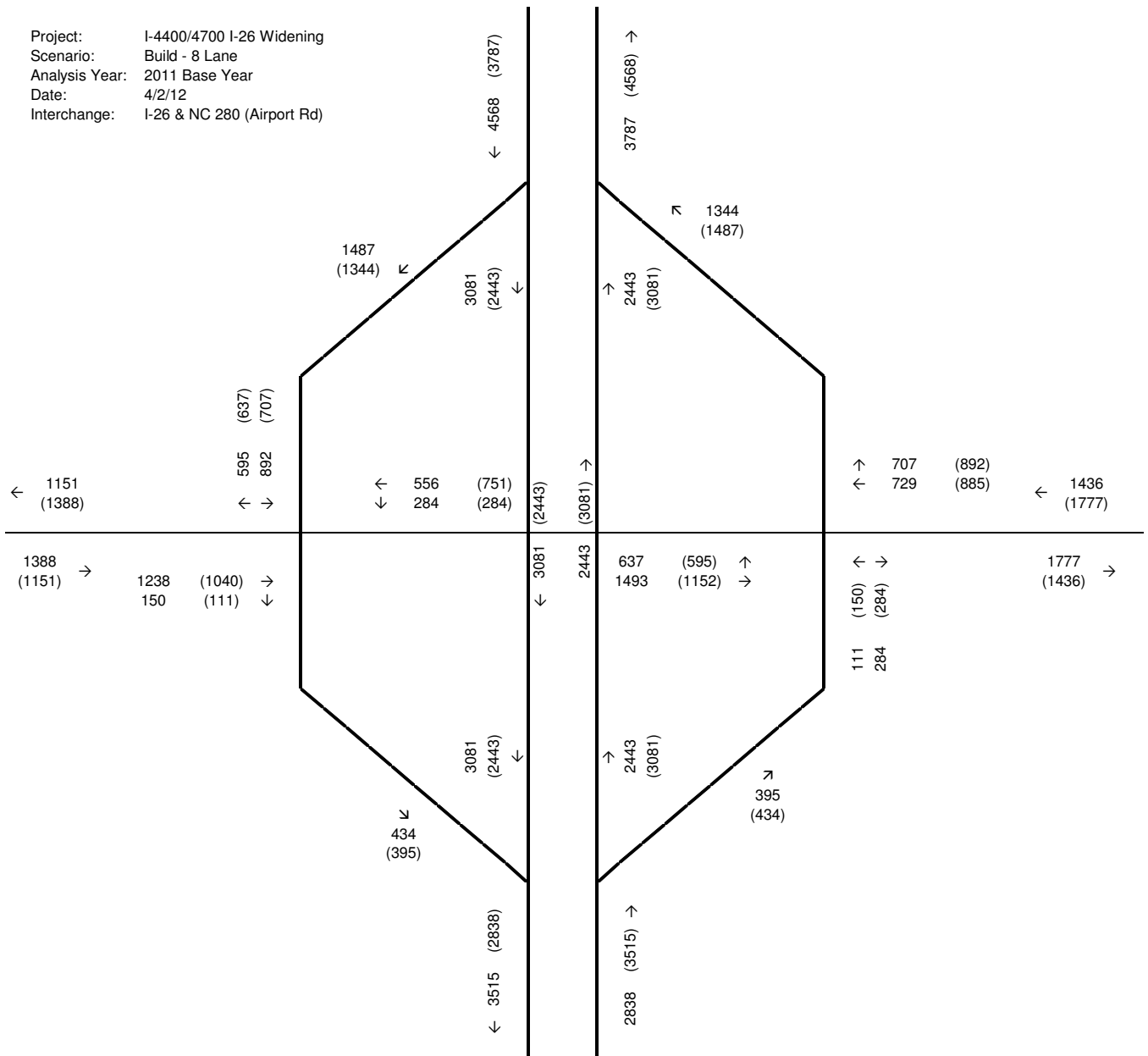

Project: I-4400/4700 I-26 Widening
 Scenario: No-Build
 Analysis Year: 2040 No-Build
 Date: 4/2/12
 Interchange: NC 280 (Airport Rd) & North/South

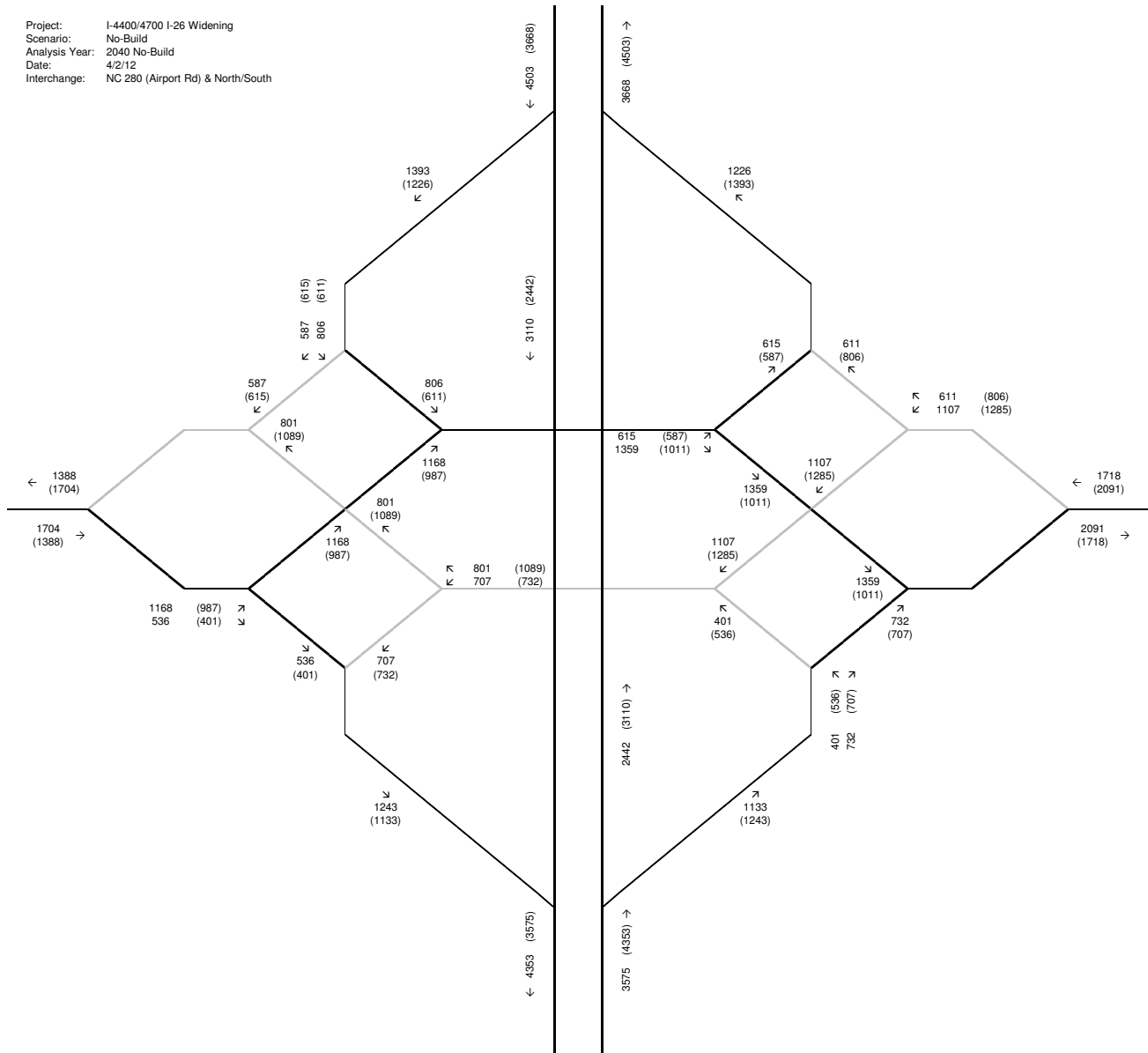

Project: I-4400/4700 I-26 Widening
 Scenario: Build - 6 Lane
 Analysis Year: 2040 No-Build
 Date: 4/2/12
 Interchange: NC 280 (Airport Rd) & North/South

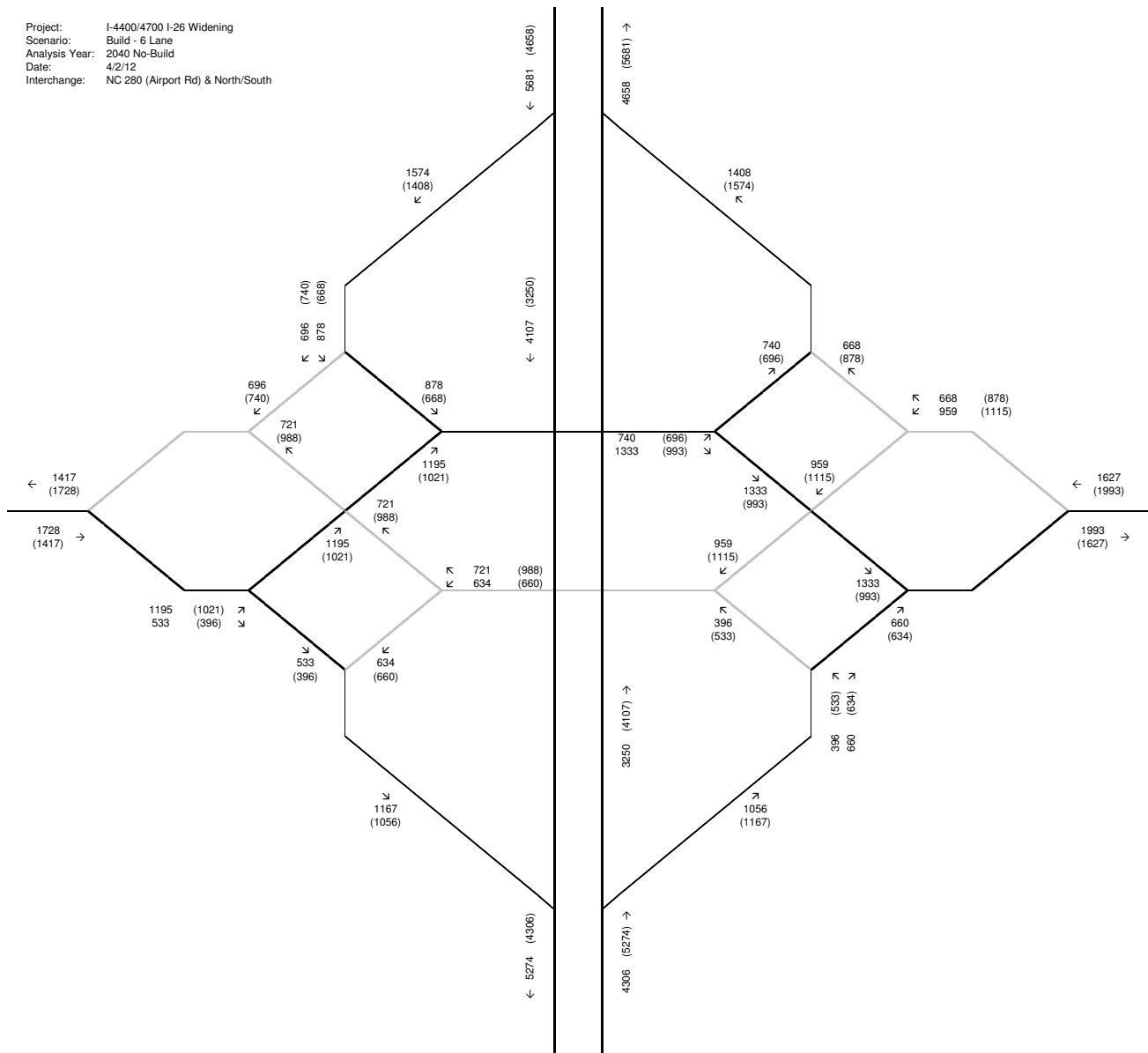

Project: I-4400/4700 I-26 Widening
 Scenario: Build - 8 Lane
 Analysis Year: 2040 No-Build
 Date: 4/2/12
 Interchange: NC 280 (Airport Rd) & North/South

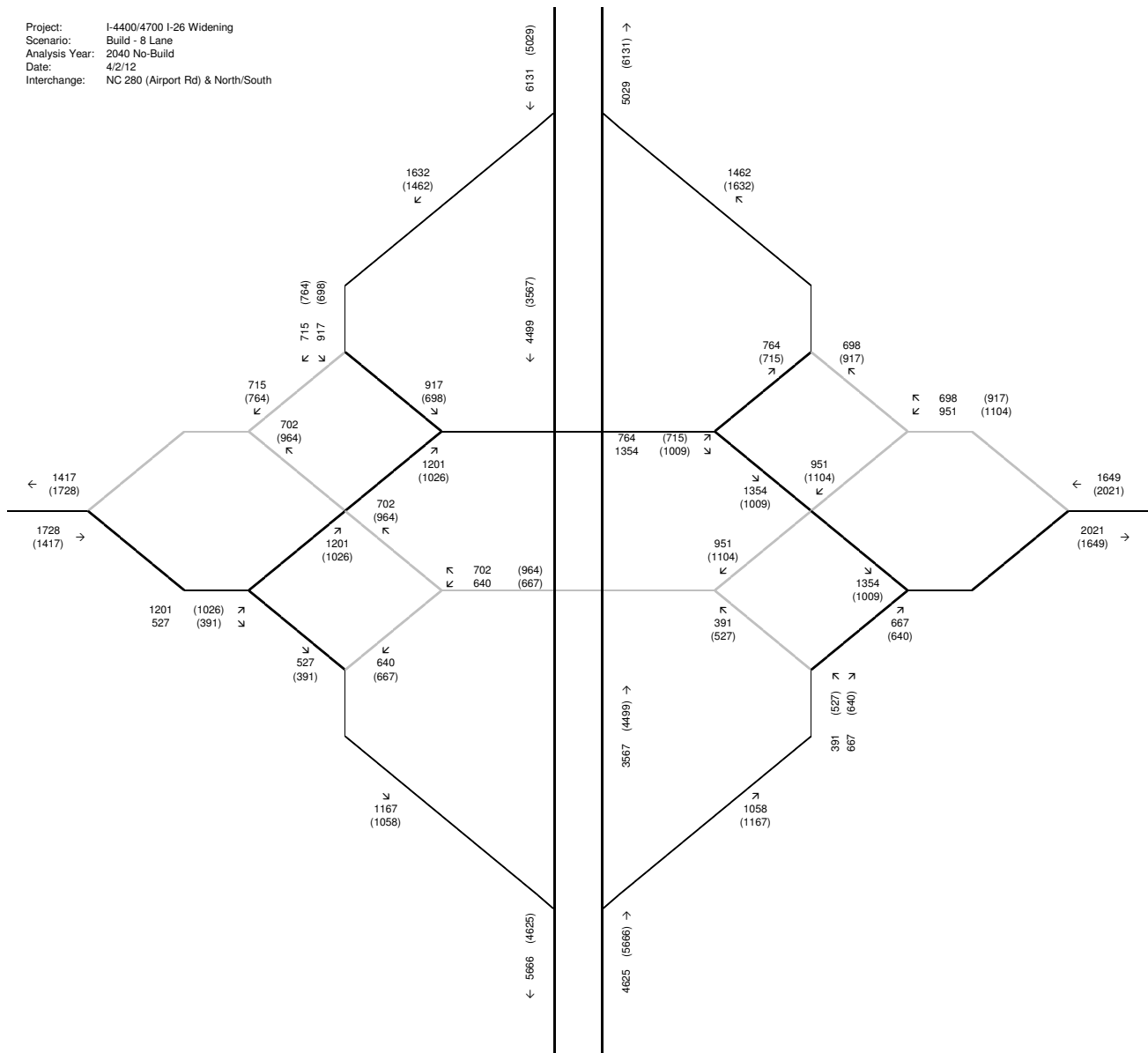

Project: I-4400/4700 I-26 Widening
 Scenario: No Build
 Analysis Year: 2011 Base Year
 Date: 4/2/12
 Interchange: I-26 & US 25

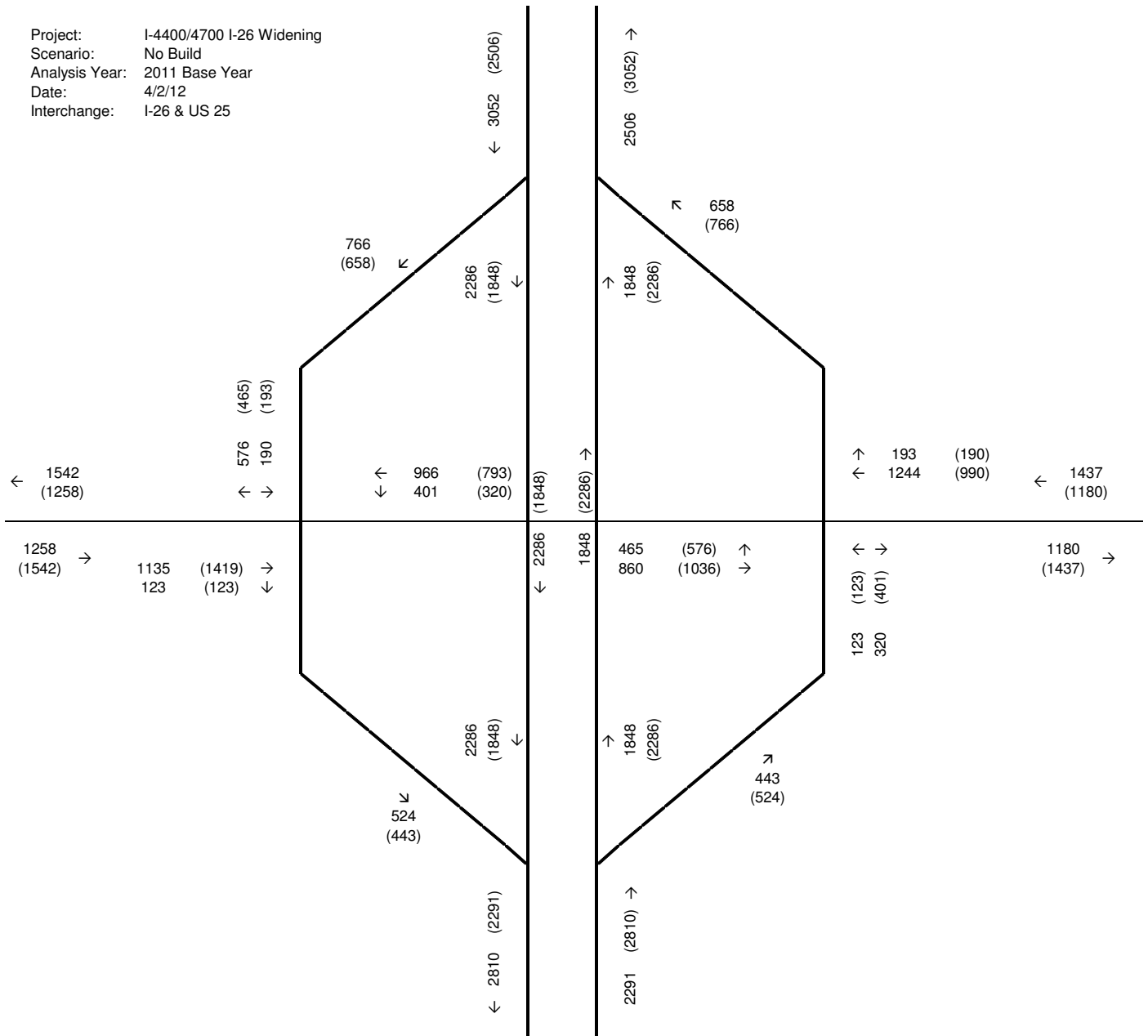

Project: I-4400/4700 I-26 Widening
 Scenario: Build - 6 Lanes
 Analysis Year: 2011 Base Year
 Date: 4/2/12
 Interchange: I-26 & US 25

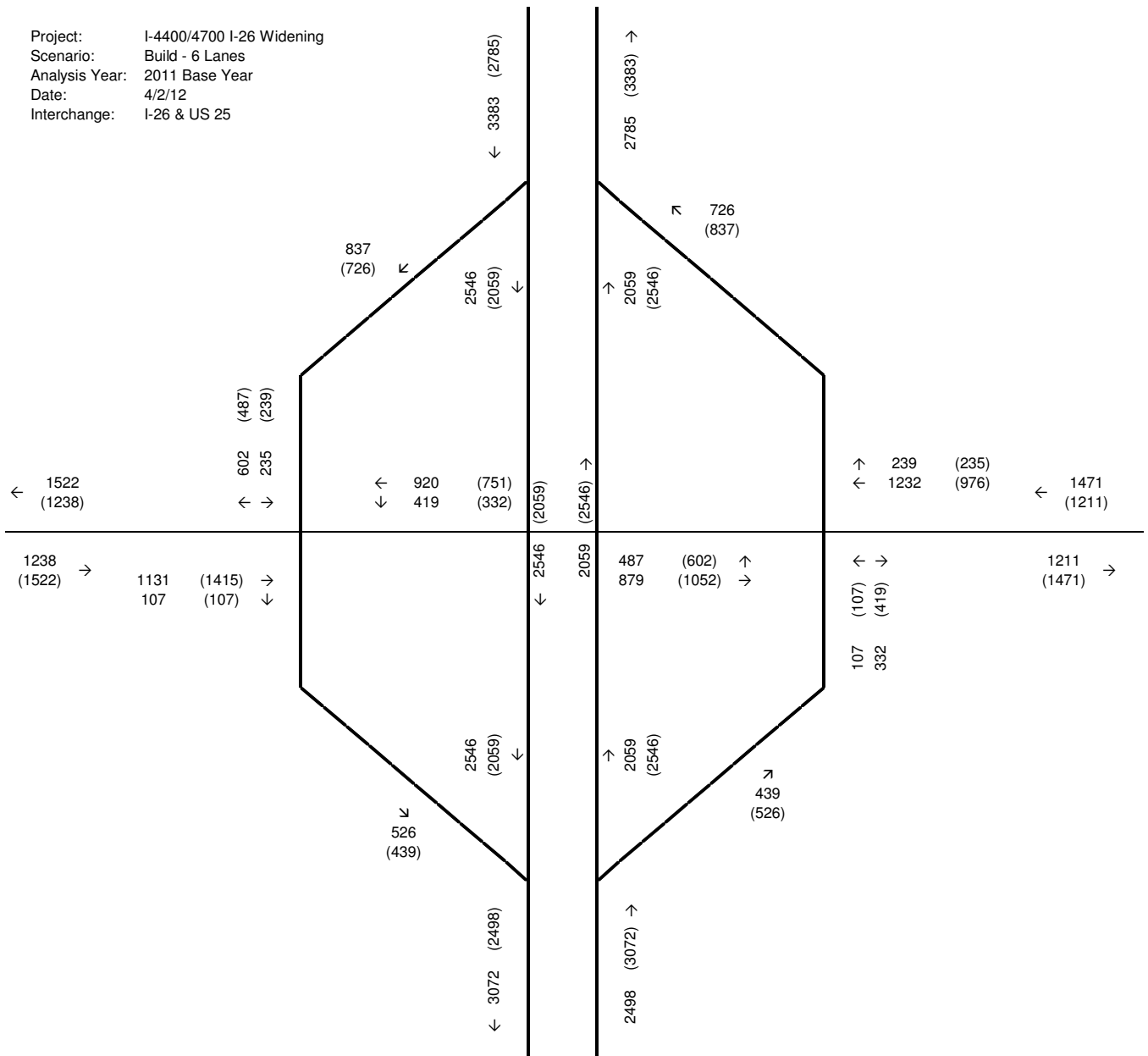

Project: I-4400/4700 I-26 Widening
 Scenario: Build - 8 Lanes
 Analysis Year: 2011 Base Year
 Date: 4/2/12
 Interchange: I-26 & US 25

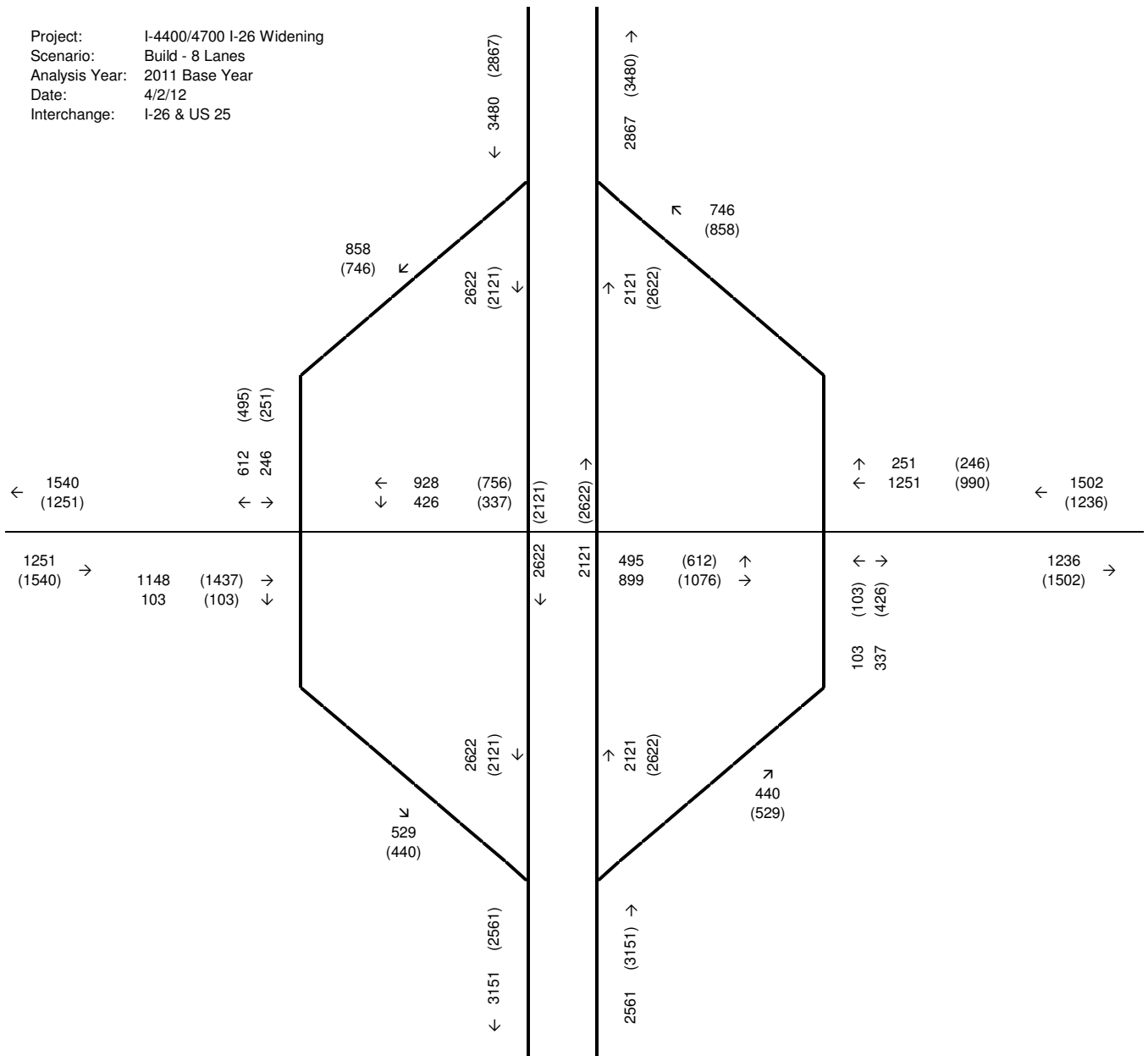

Project: I-4400/4700 I-26 Widening
 Scenario: No-Build
 Analysis Year: 2040 Design Year
 Date: 4/2/12
 Interchange: I-26 & US 25

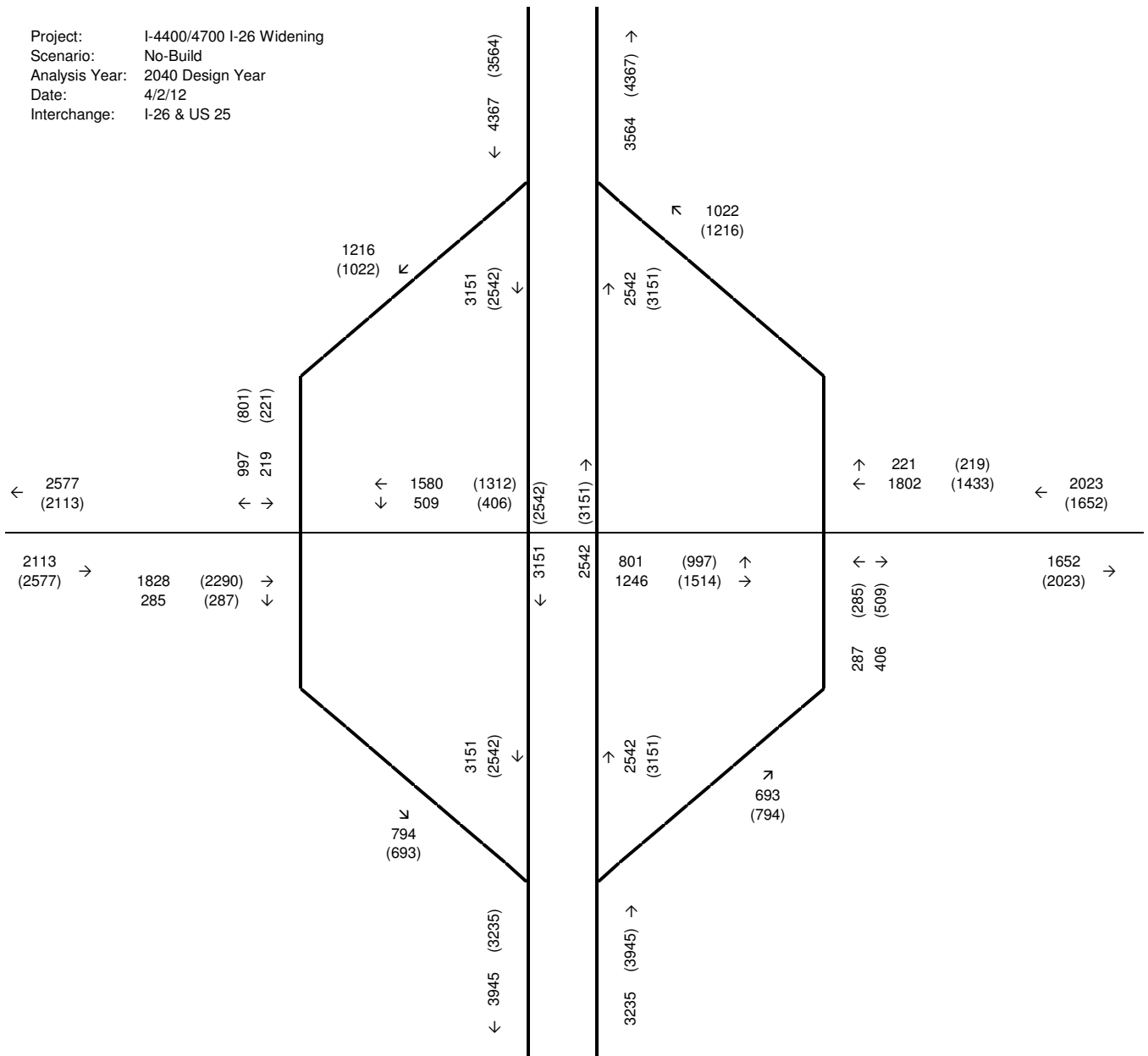

Project: I-4400/4700 I-26 Widening
 Scenario: Build - 6 Lanes
 Analysis Year: 2040 Design Year
 Date: 4/2/12
 Interchange: I-26 & US 25

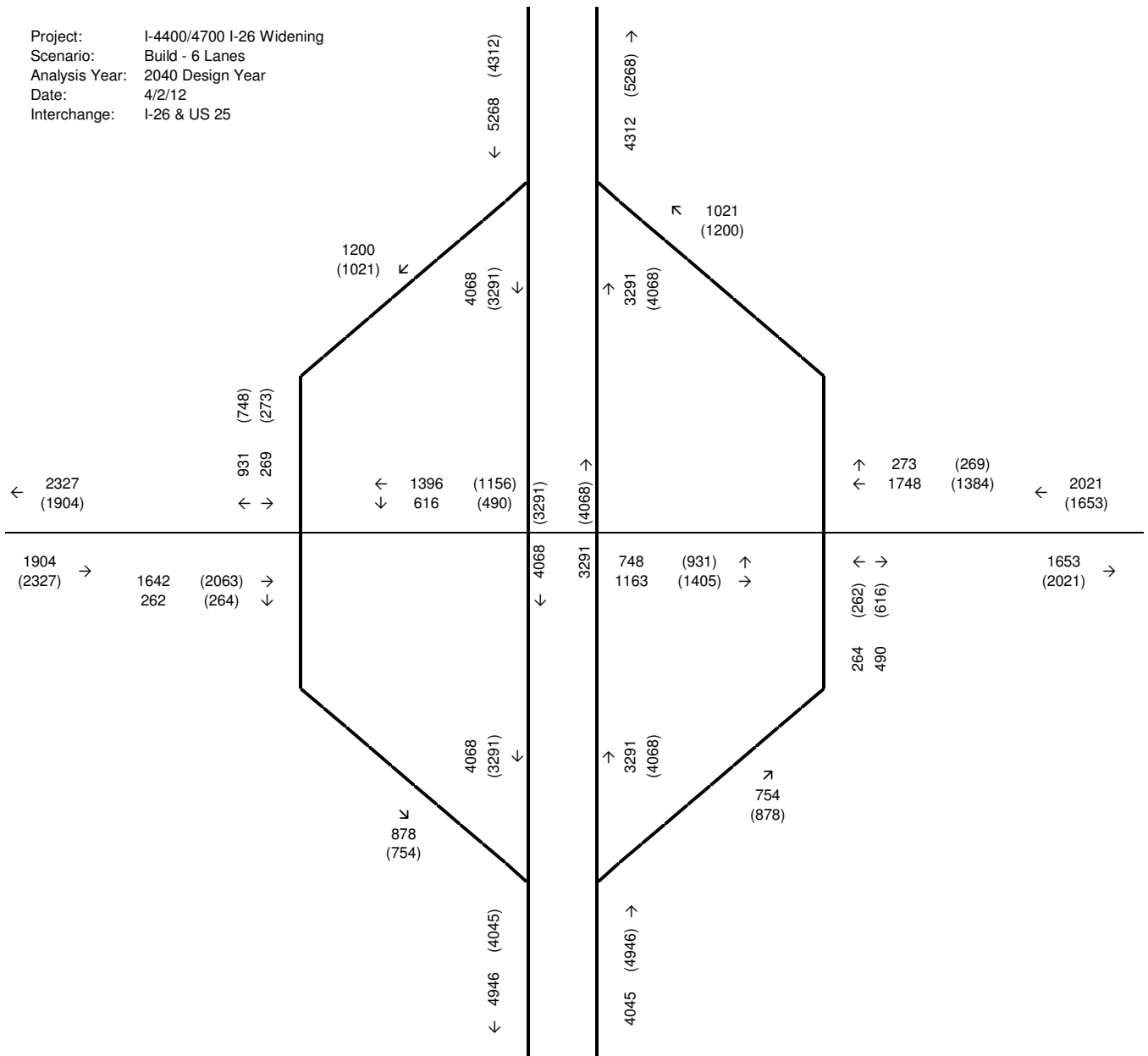

Project: I-4400/4700 I-26 Widening
 Scenario: Build - 8 Lanes
 Analysis Year: 2040 Design Year
 Date: 4/2/12
 Interchange: I-26 & US 25

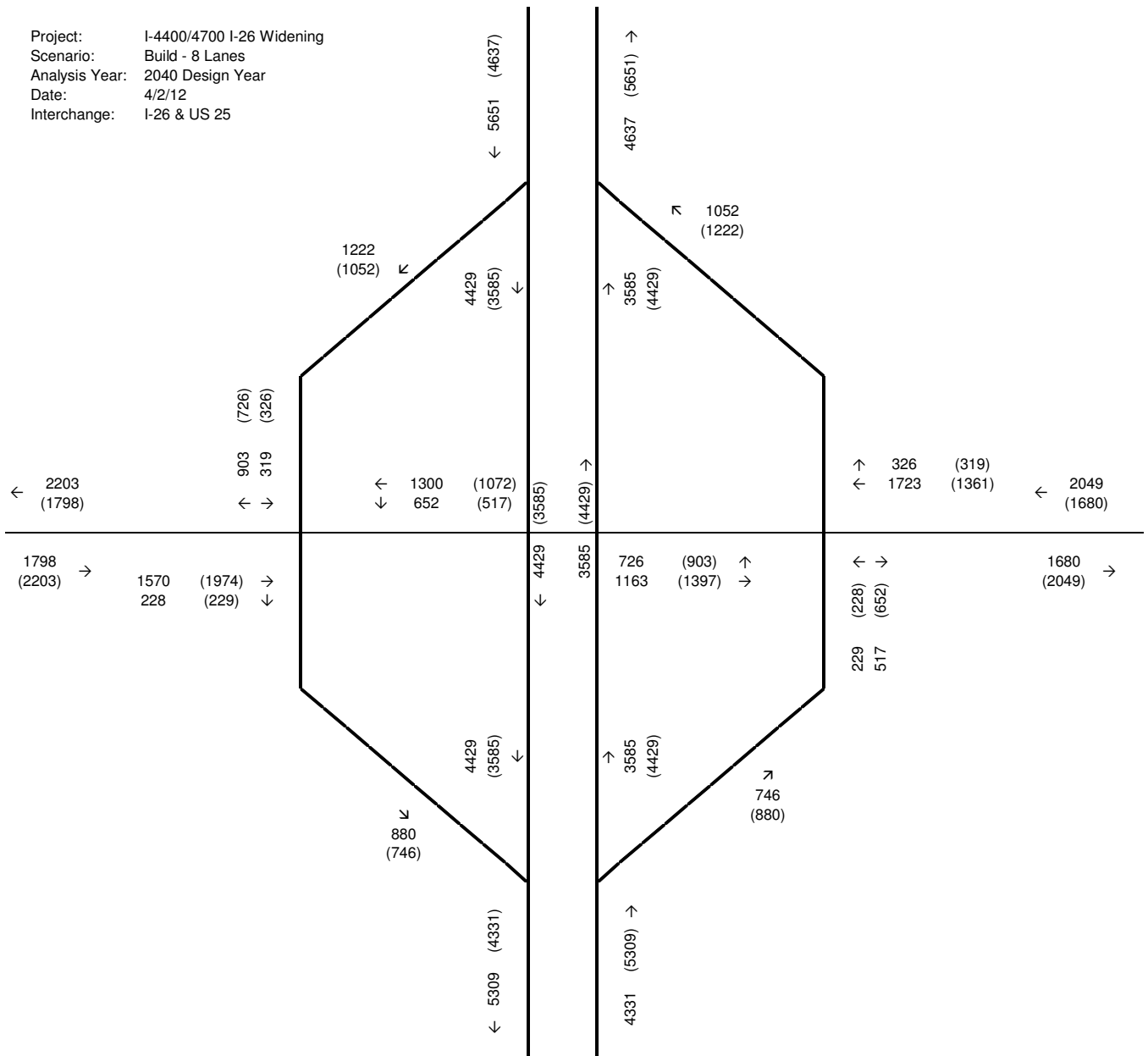

Project: I-26 Corridor Study
 Scenario: No Build
 Analysis Year: 2040
 Date: 4/11/2013
 Interchange: I-26 & Future Balfour Parkway

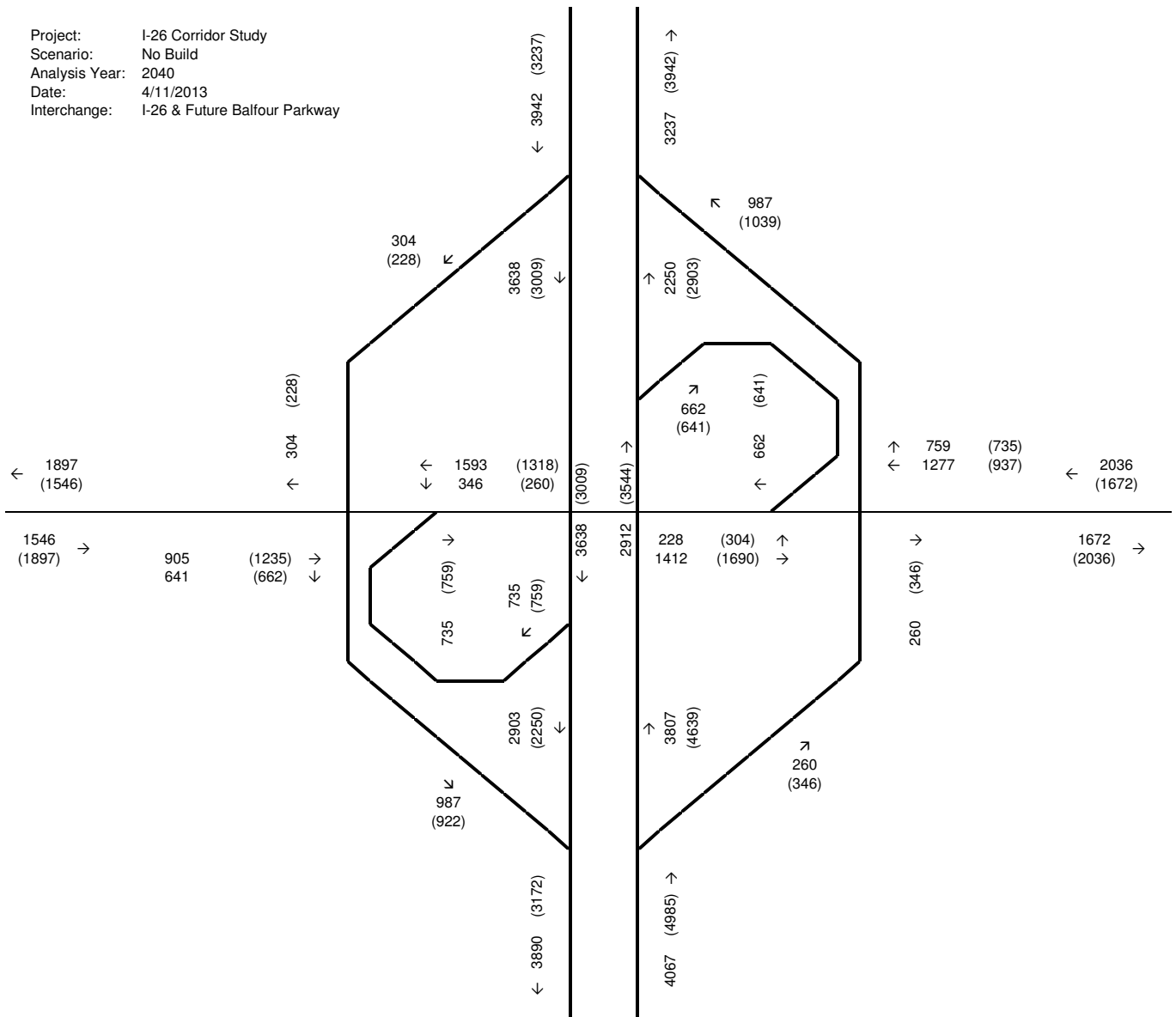

Project: I-26 Corridor Study
 Scenario: Eight Lane
 Analysis Year: 2040
 Date: 4/11/2013
 Interchange: I-26 & Future Balfour Parkway

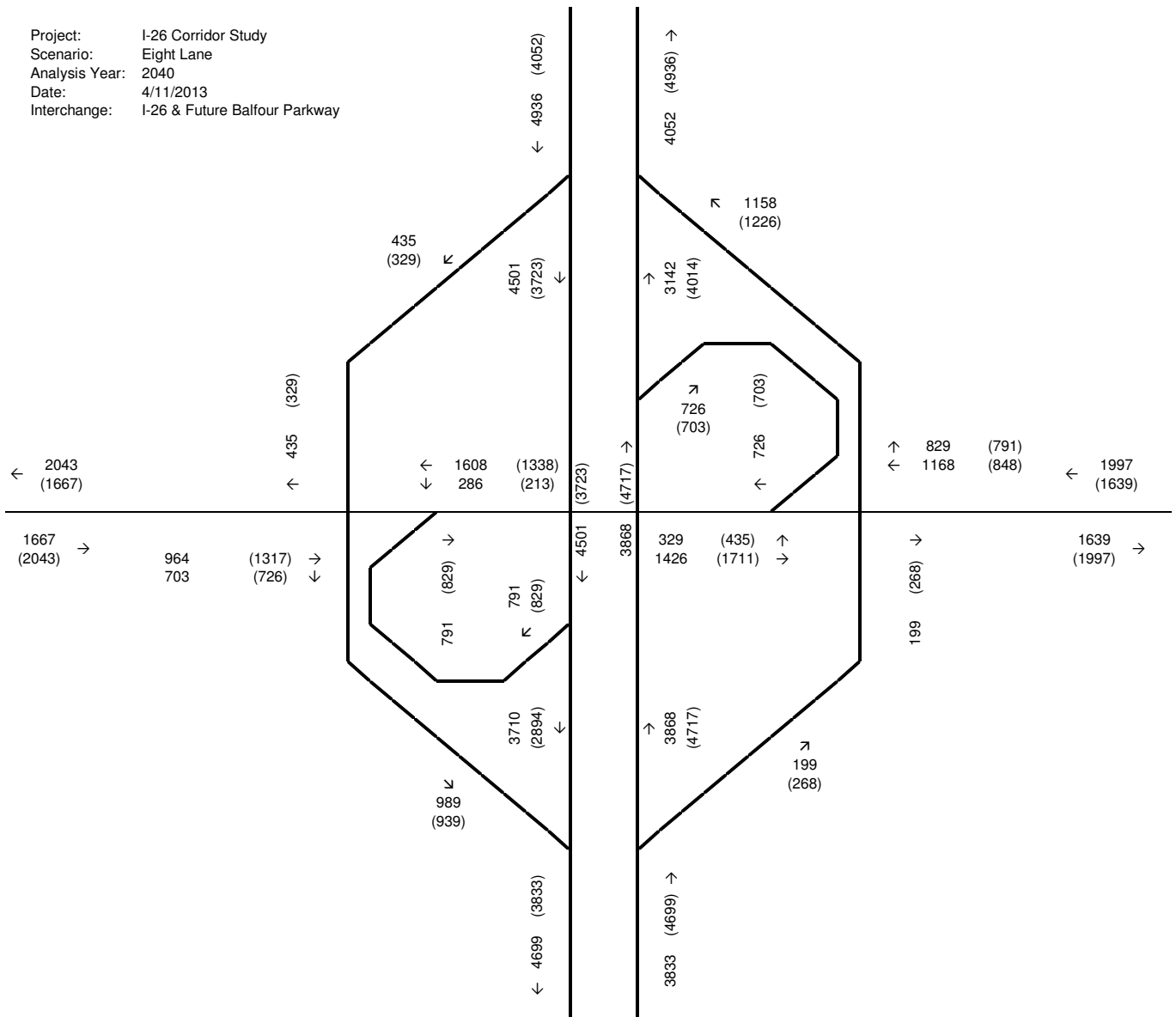

Project: I-26 Corridor Study
 Scenario: Eight Lane
 Analysis Year: 2040
 Date: 4/11/2013
 Interchange: I-26 & Future Balfour Parkway

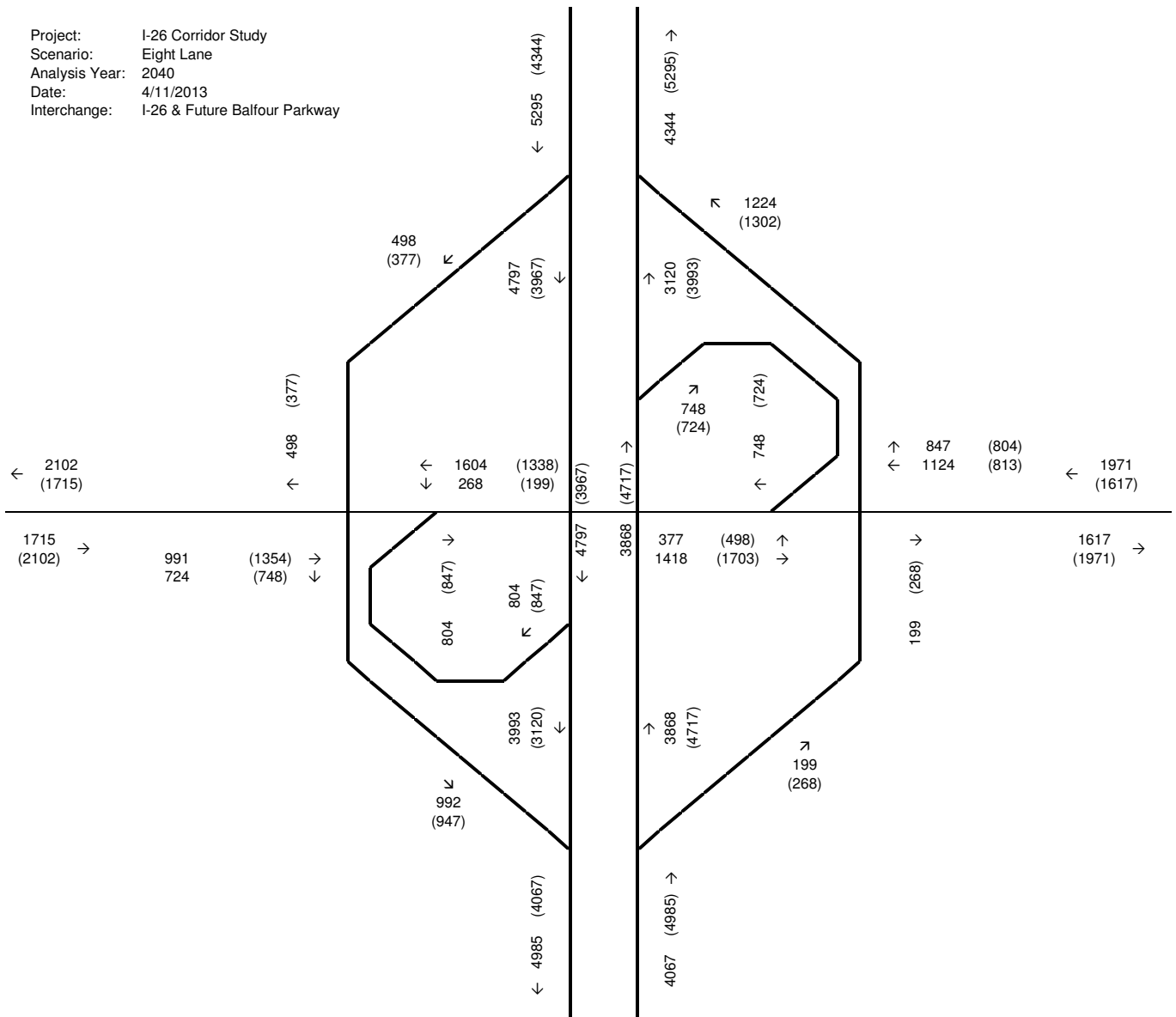

Project: I-4400/4700 I-26 Widening
 Scenario: No-Build
 Analysis Year: 2011 Base Year
 Date: 4/2/12
 Interchange: I-26 & US 64

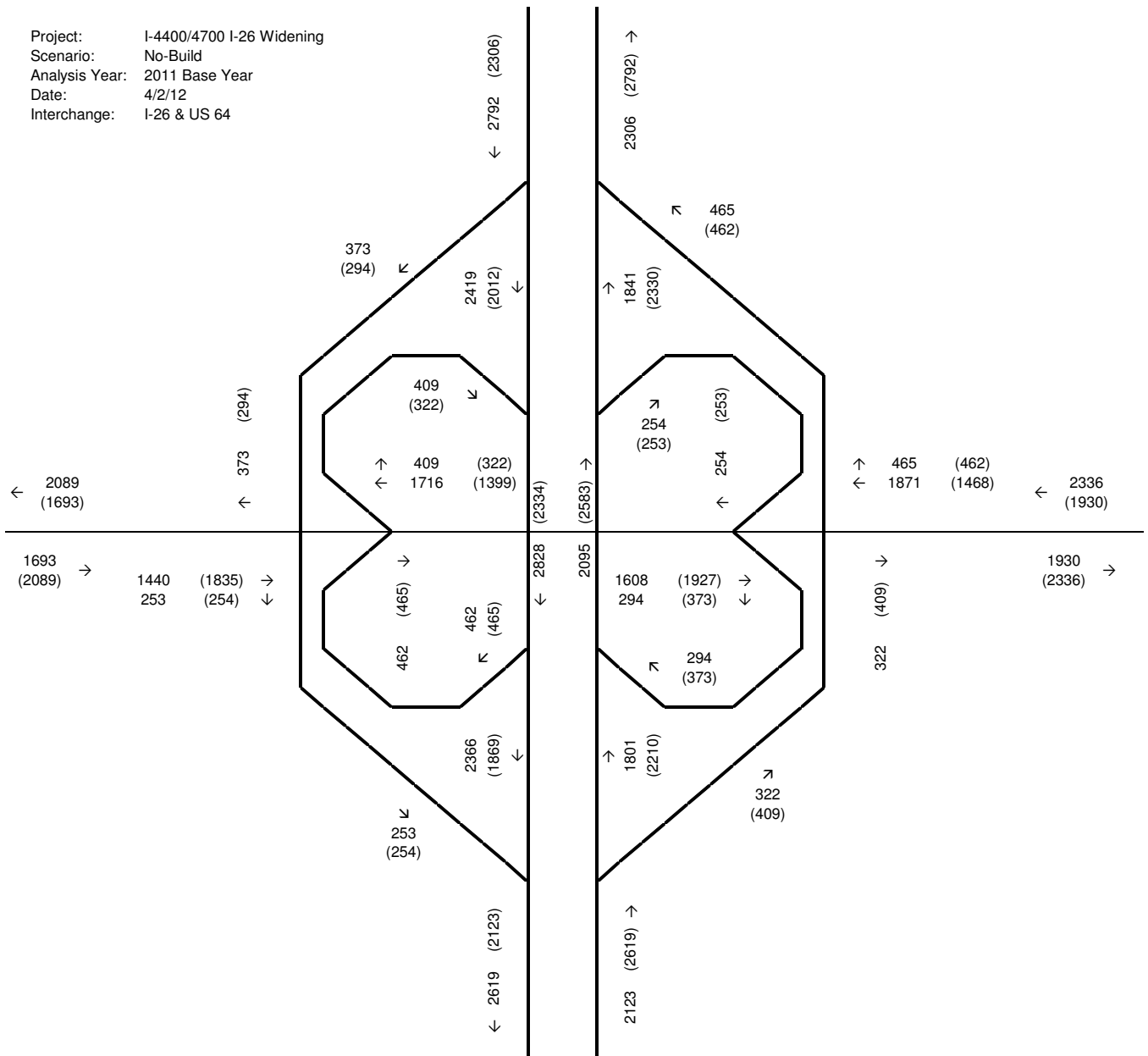

Project: I-4400/4700 I-26 Widening
 Scenario: Build - 6 Lanes
 Analysis Year: 2011 Base Year
 Date: 4/2/12
 Interchange: I-26 & US 64

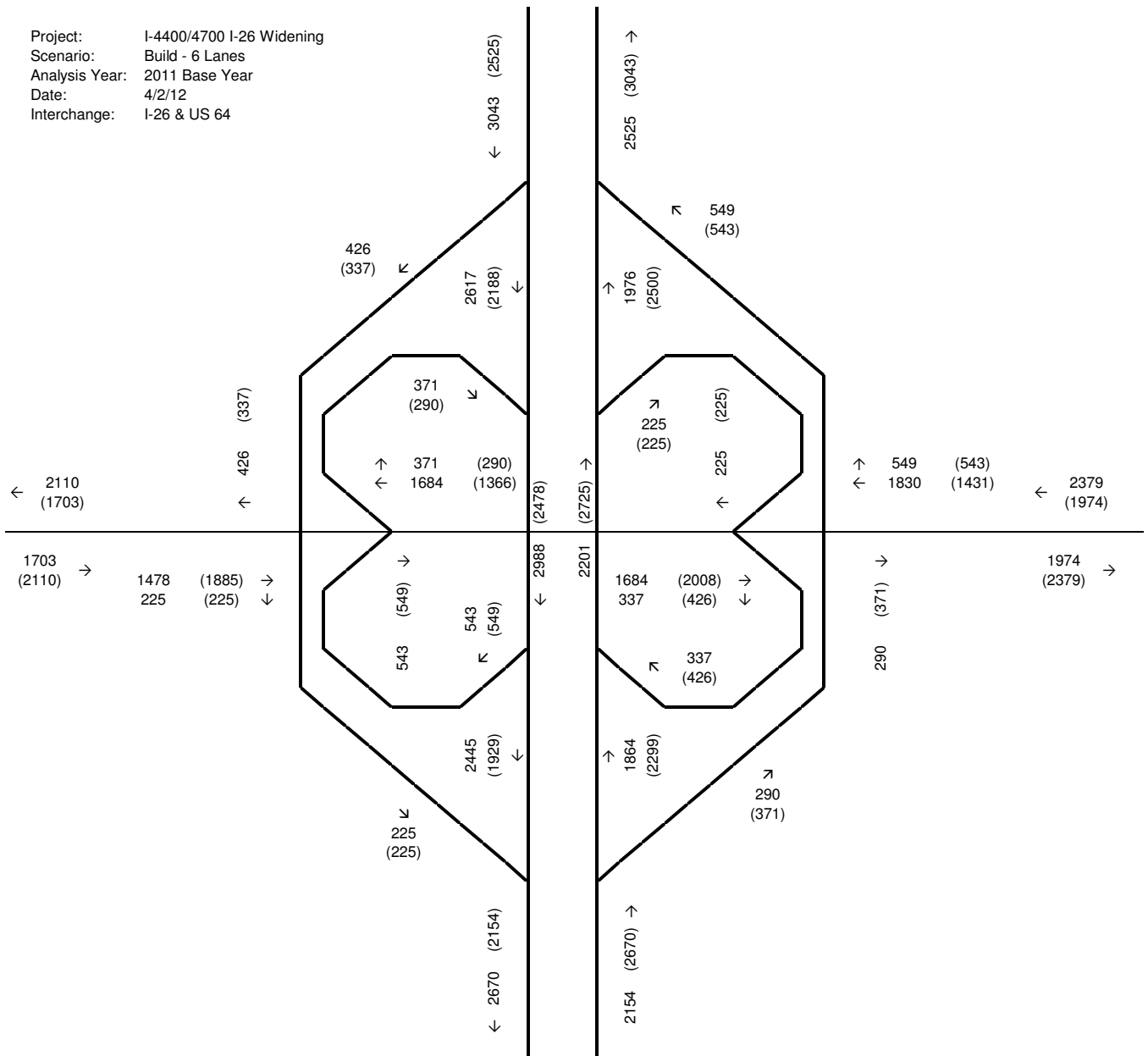

Project: I-4400/4700 I-26 Widening
 Scenario: Build - 8 Lanes
 Analysis Year: 2011 Base Year
 Date: 4/2/12
 Interchange: I-26 & US 64

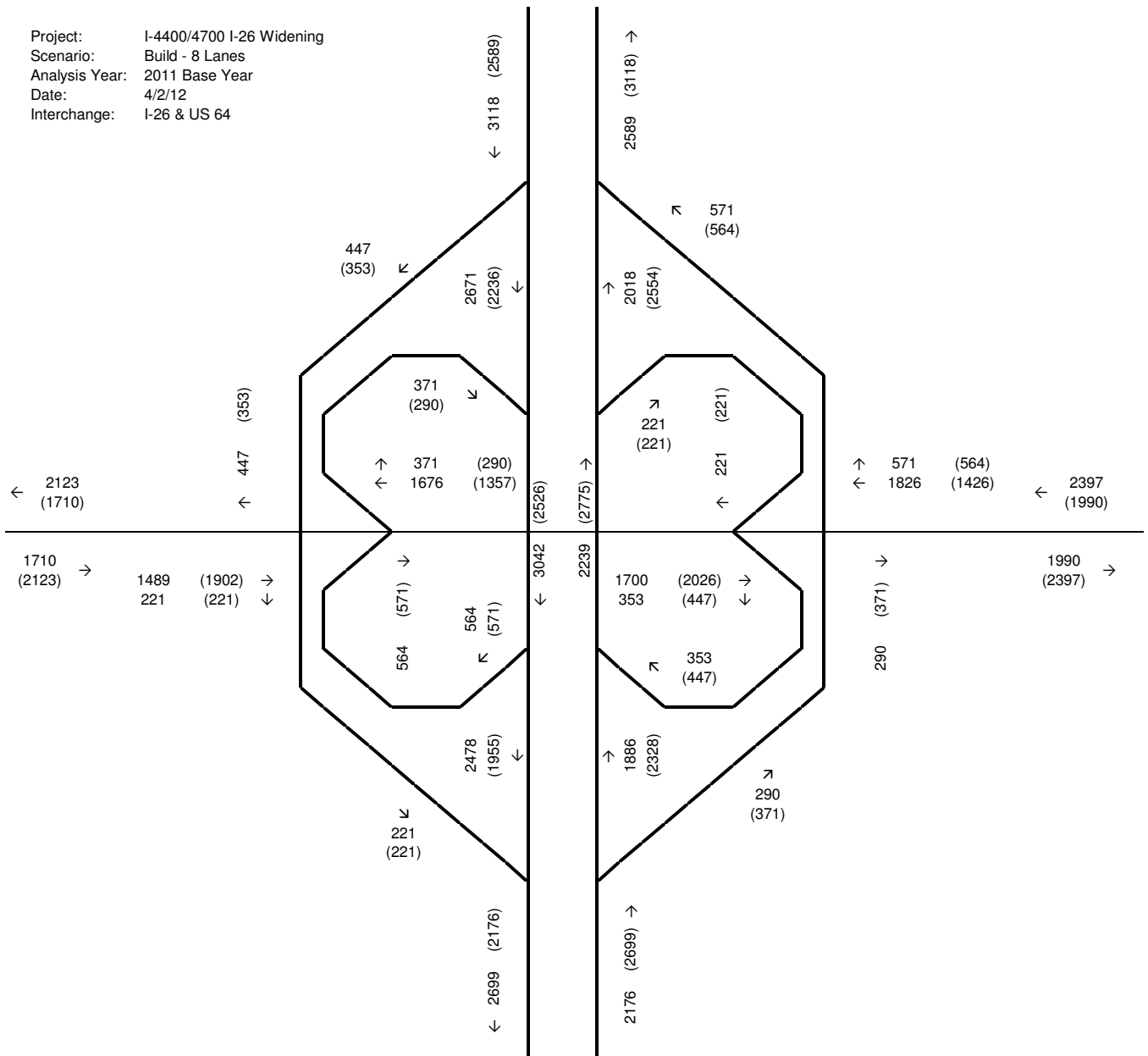

Project: I-4400/4700 I-26 Widening
 Scenario: No-Build
 Analysis Year: 2040 Design Year
 Date: 4/2/12
 Interchange: I-26 & US 64

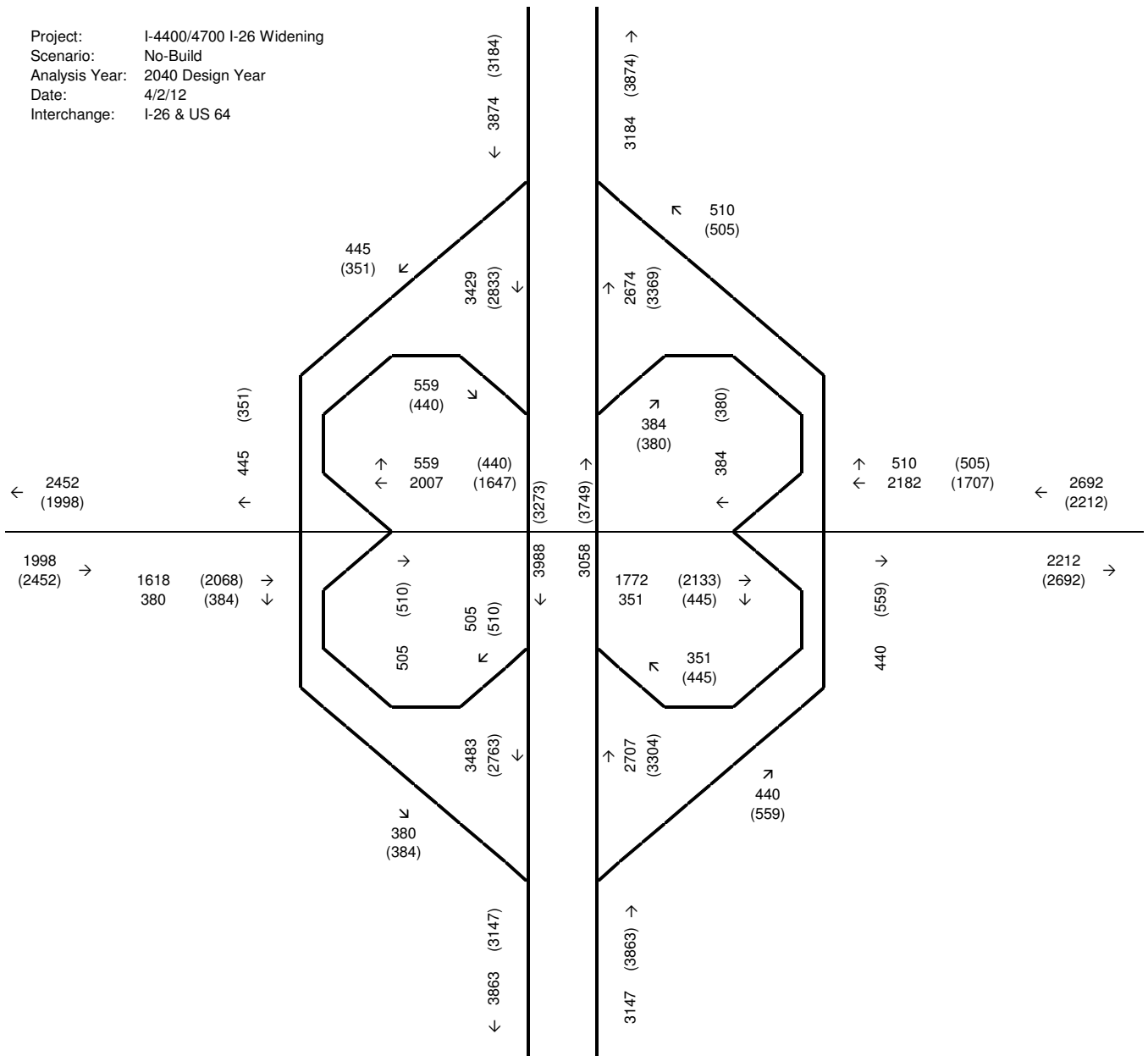

Project: I-4400/4700 I-26 Widening
 Scenario: Build - 6 Lanes
 Analysis Year: 2040 Design Year
 Date: 4/2/12
 Interchange: I-26 & US 64

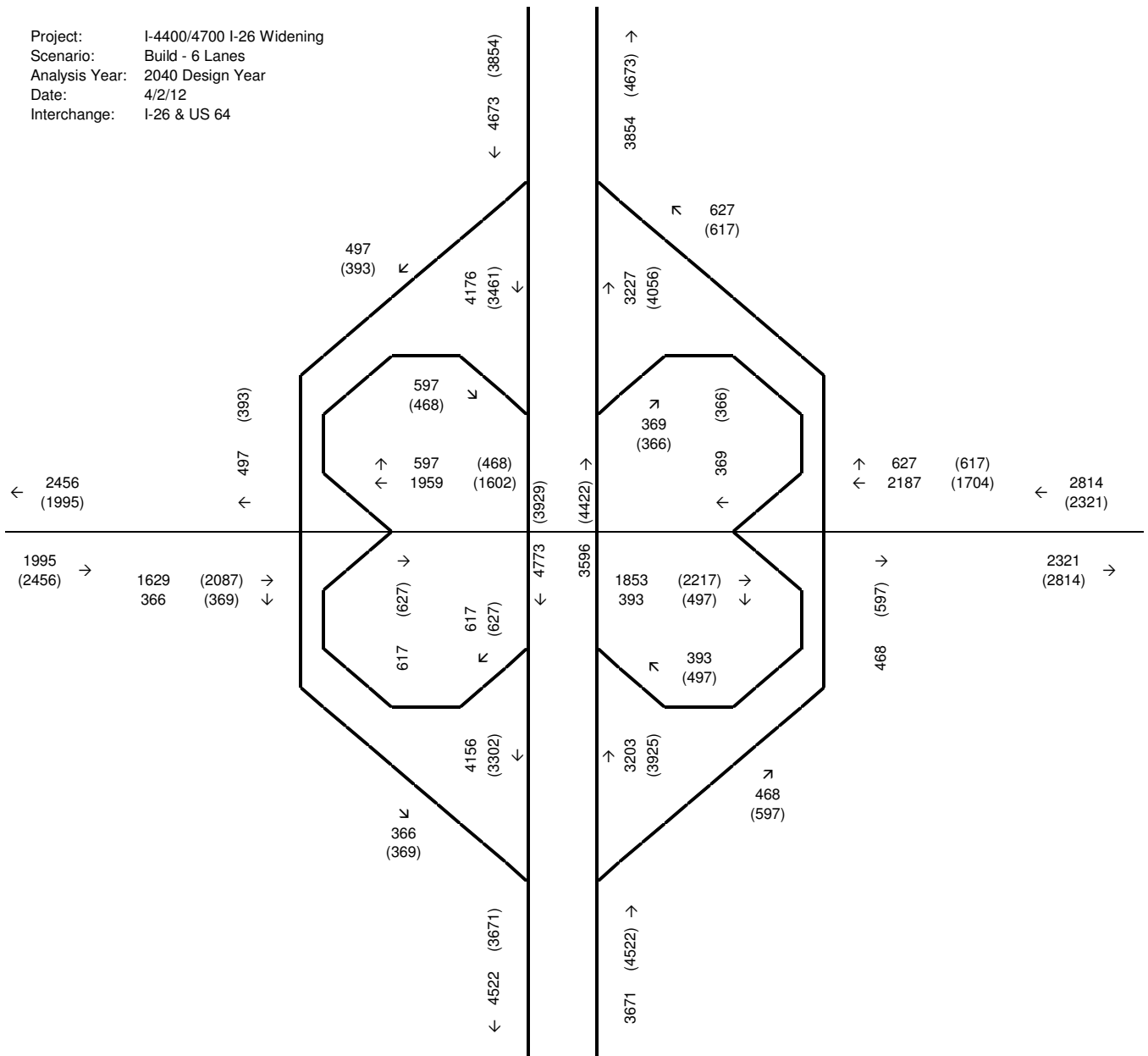

Project: I-4400/4700 I-26 Widening
 Scenario: Build - 8 Lanes
 Analysis Year: 2040 Design Year
 Date: 4/2/12
 Interchange: I-26 & US 64

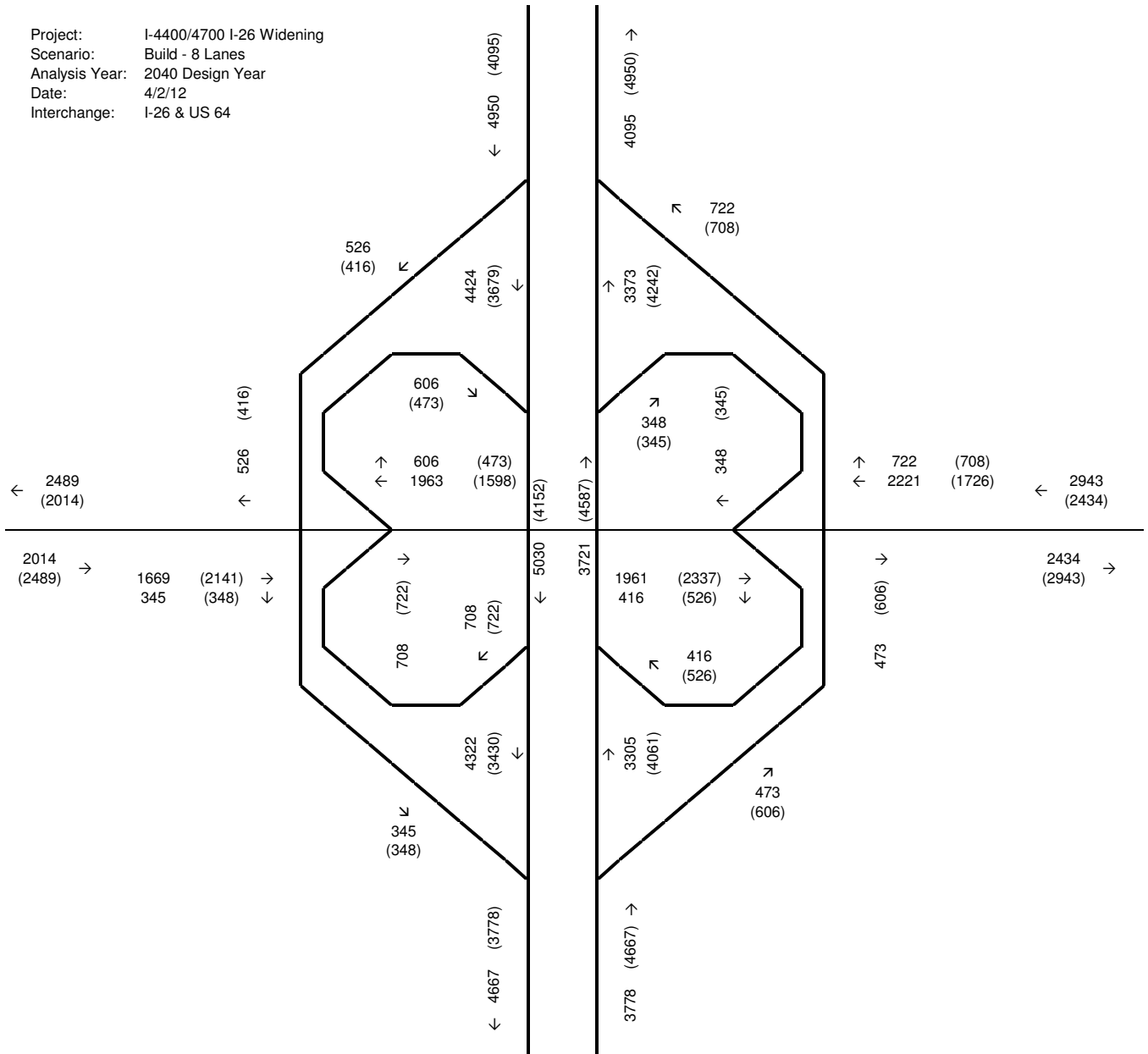

Project: I-4400/4700 I-26 Widening
 Scenario: No-Build
 Analysis Year: 2011 Base Year
 Date: 4/2/12
 Interchange: I-26 & SR 1783 (Upward Rd)

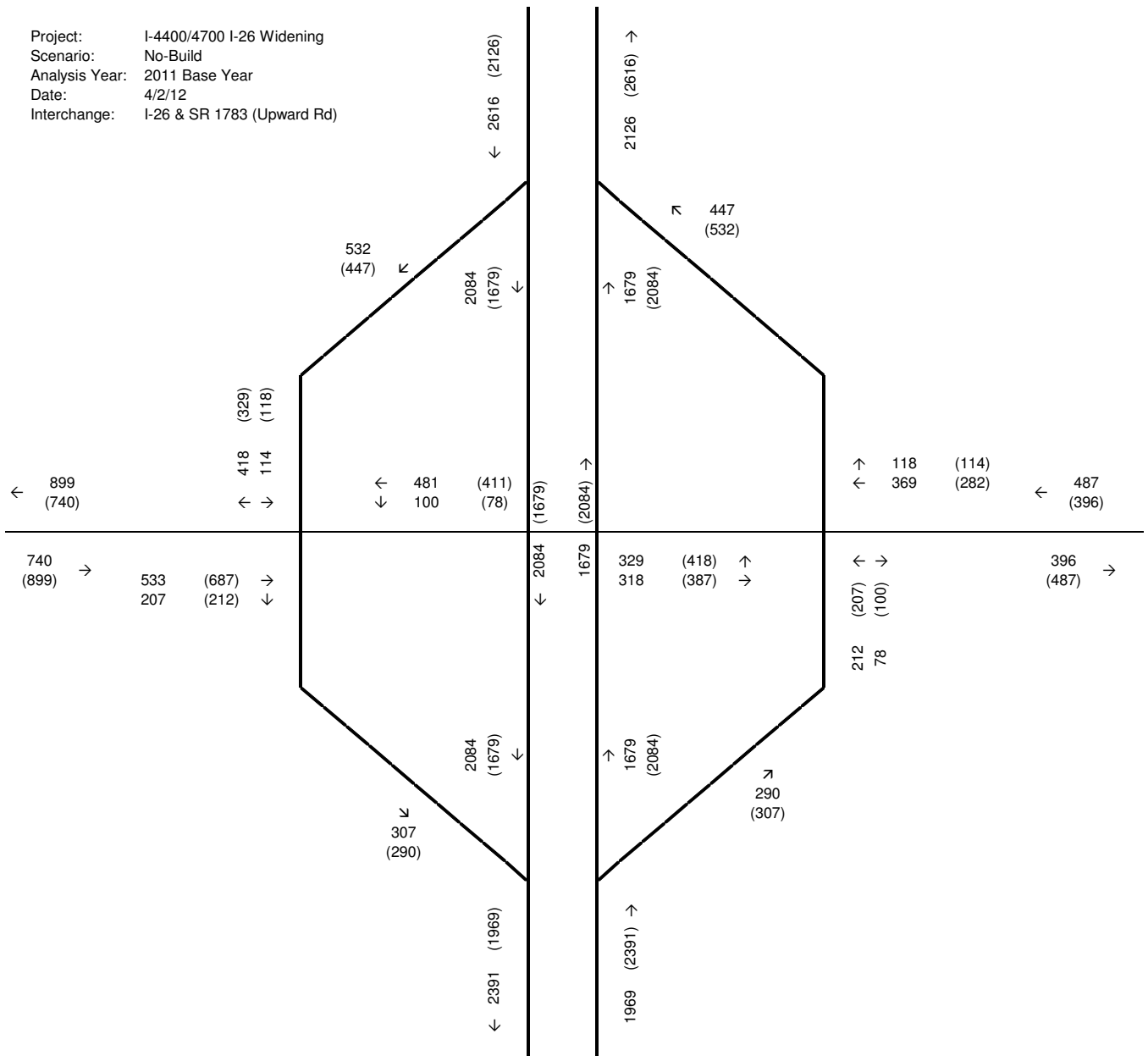

Project: I-4400/4700 I-26 Widening
 Scenario: Build - 6 Lanes
 Analysis Year: 2011 Base Year
 Date: 4/2/12
 Interchange: I-26 & SR 1783 (Upward Rd)

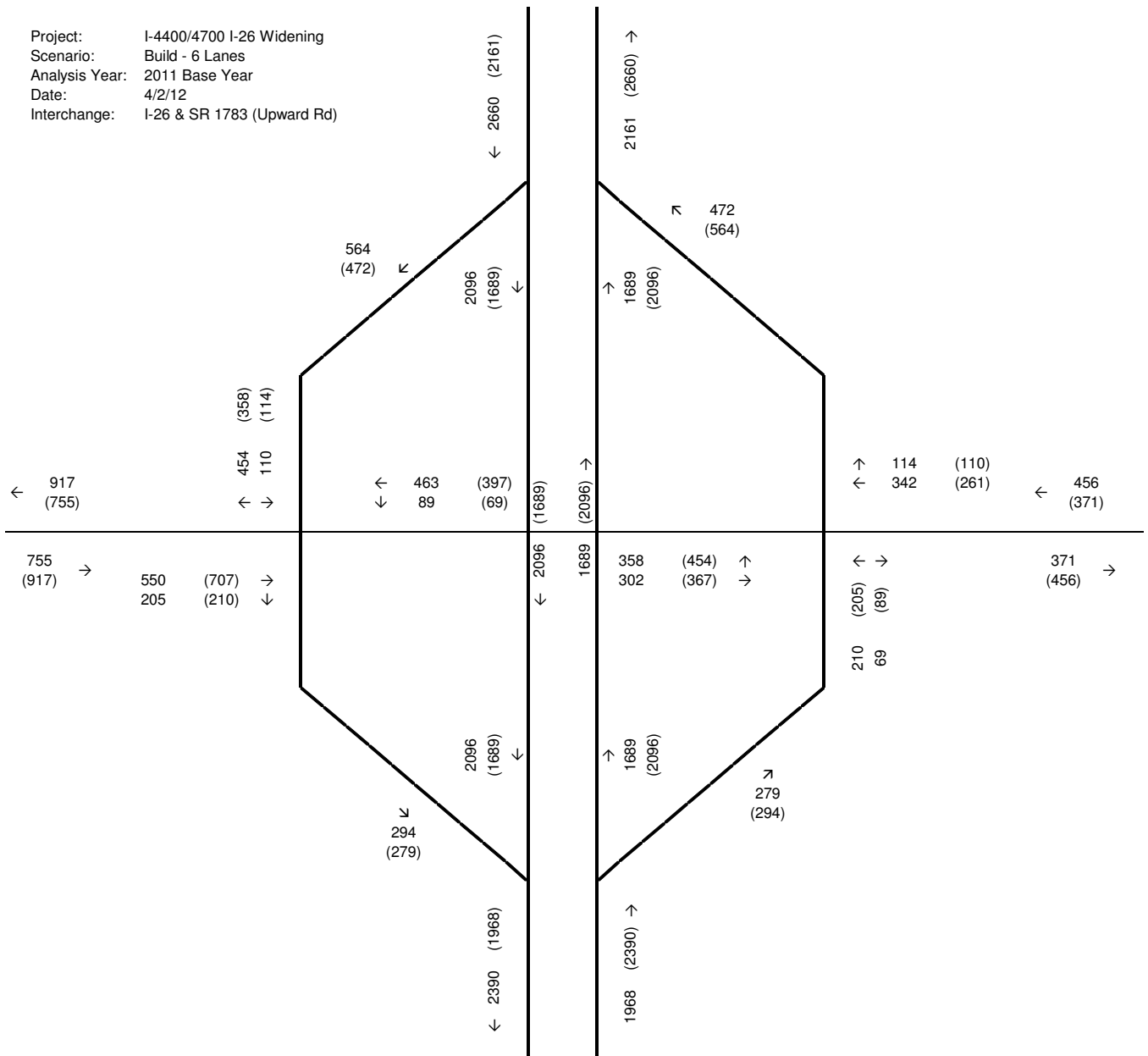

Project: I-4400/4700 I-26 Widening
 Scenario: Build - 8 Lanes
 Analysis Year: 2011 Base Year
 Date: 4/2/12
 Interchange: I-26 & SR 1783 (Upward Rd)

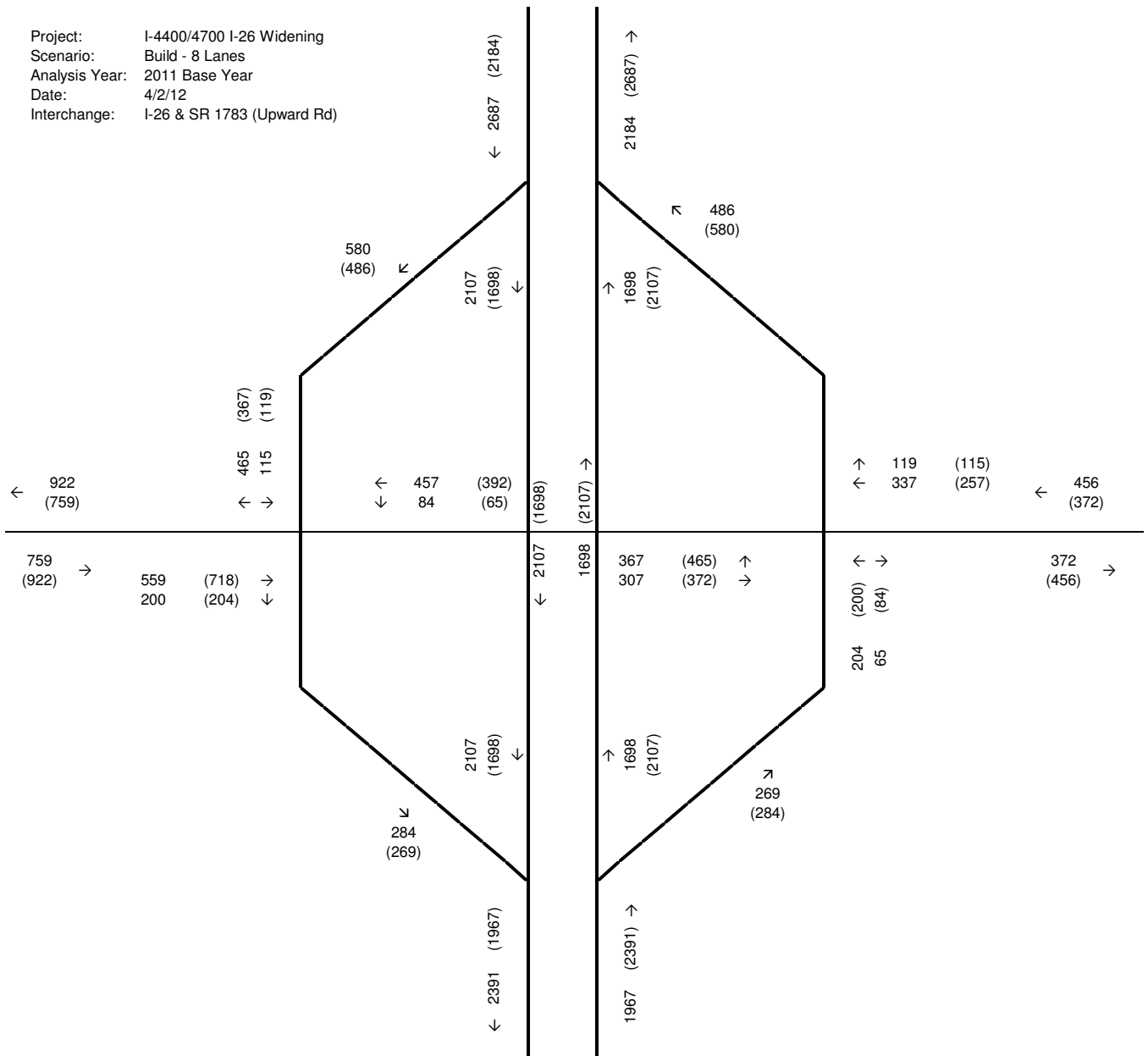

Project: I-4400/4700 I-26 Widening
 Scenario: No-Build
 Analysis Year: 2040 Design Year
 Date: 4/2/12
 Interchange: I-26 & SR 1783 (Upward Rd)

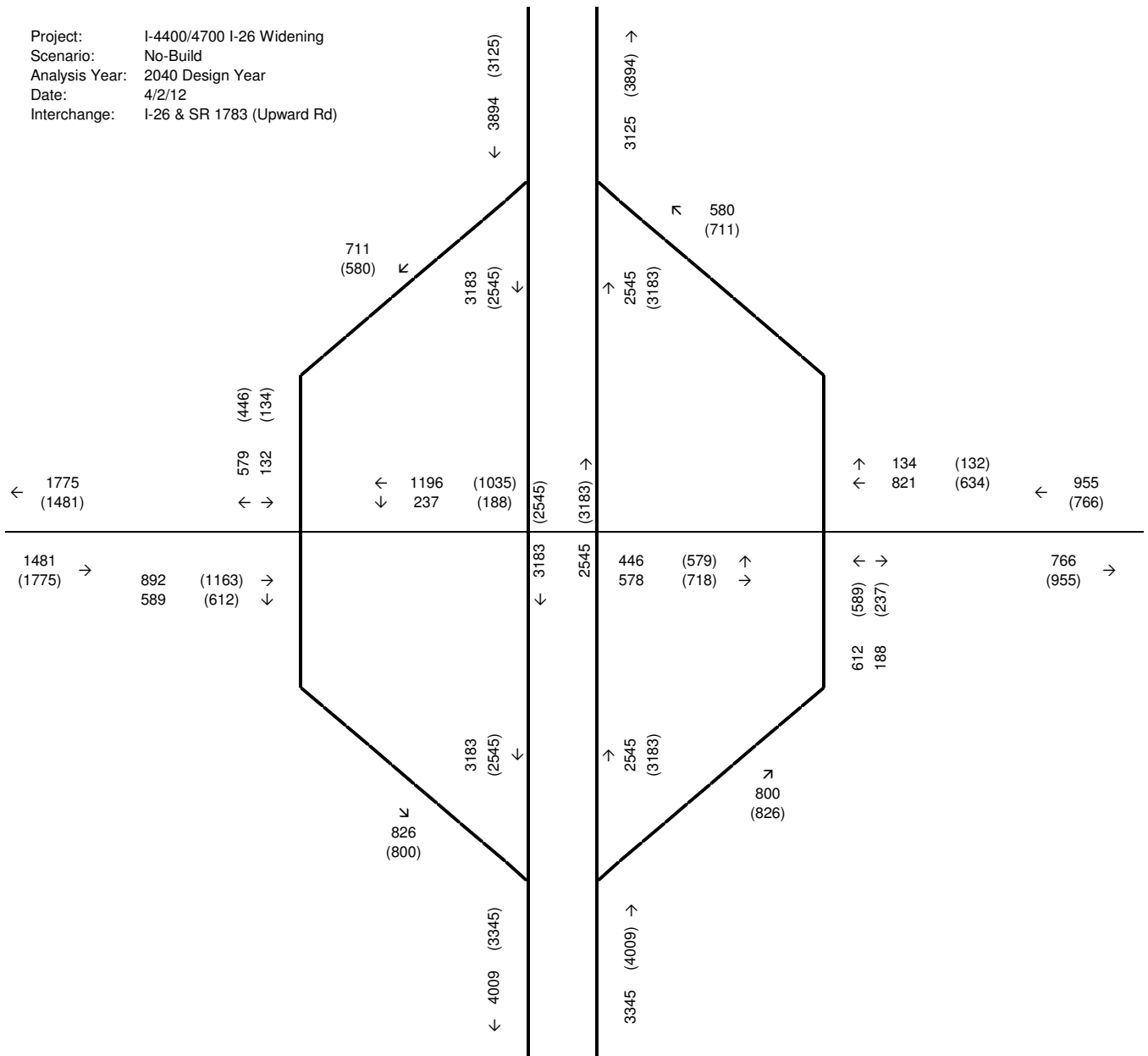

Project: I-4400/4700 I-26 Widening
 Scenario: Build - 6 Lane
 Analysis Year: 2040 Design Year
 Date: 4/2/12
 Interchange: I-26 & SR 1783 (Upward Rd)

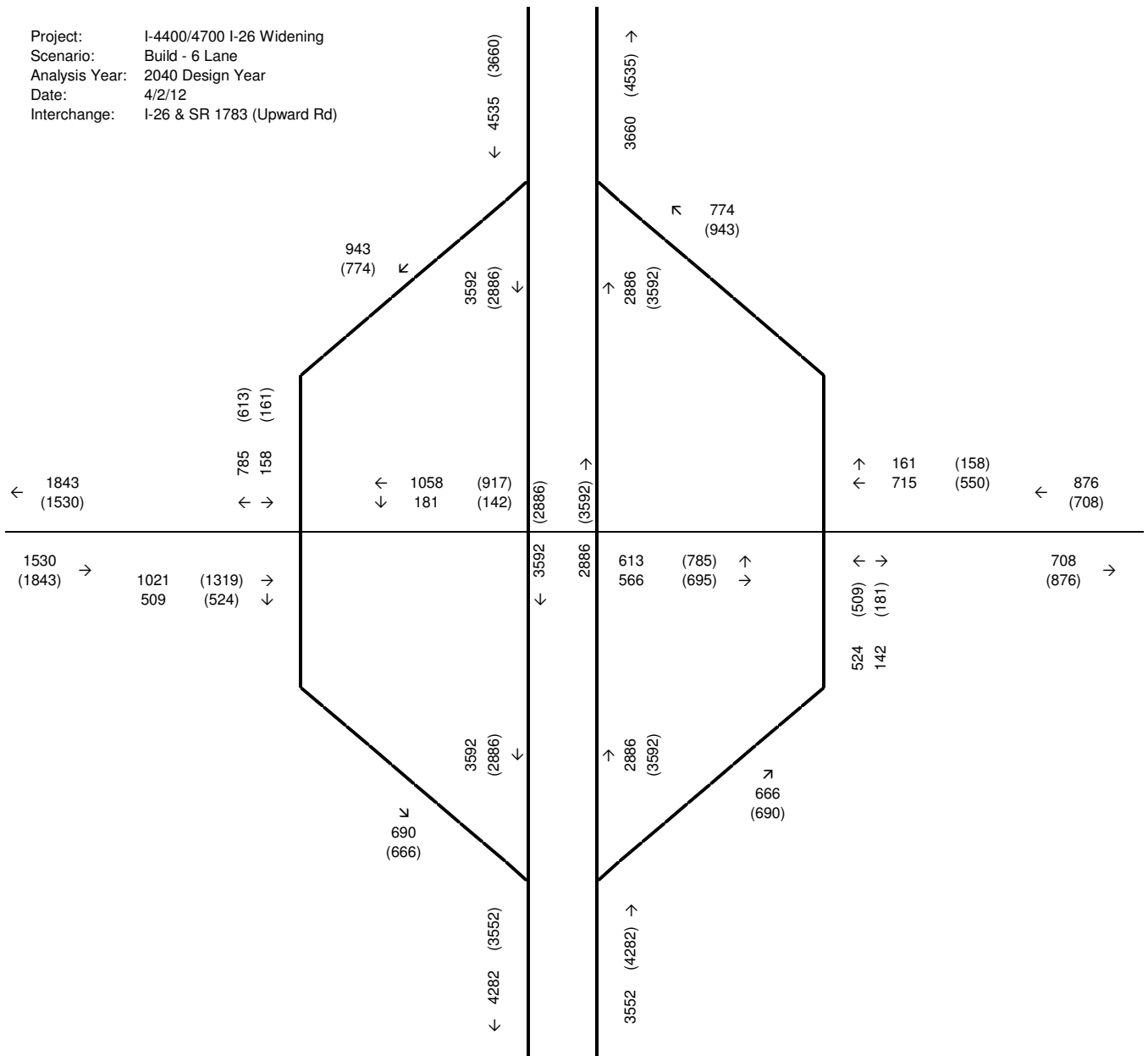

Project: I-4400/4700 I-26 Widening
 Scenario: Build - 8 Lane
 Analysis Year: 2040 Design Year
 Date: 4/2/12
 Interchange: I-26 & SR 1783 (Upward Rd)

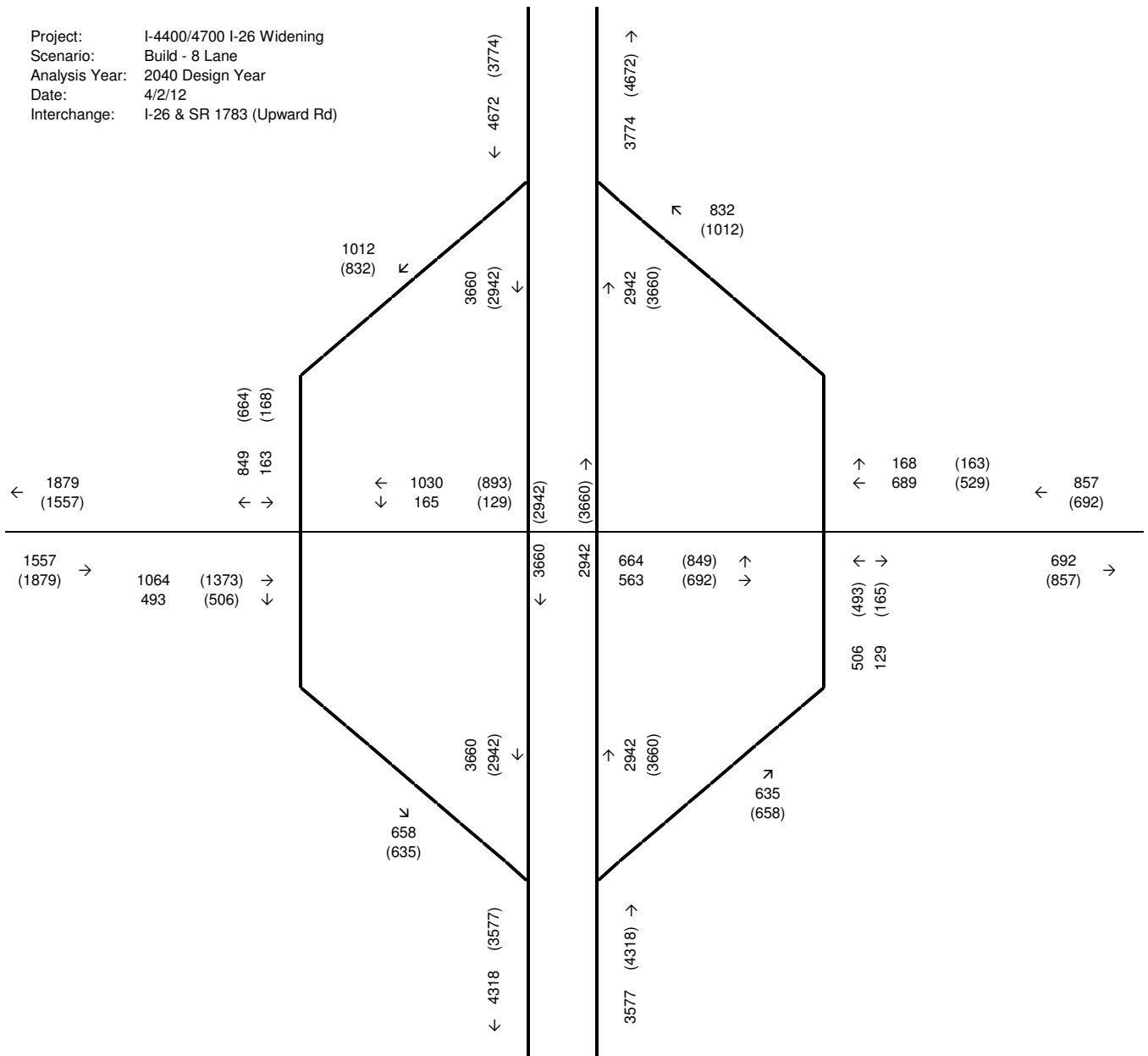

Project: I-4400/4700 I-26 Widening
 Scenario: No-Build
 Analysis Year: 2011 Base Year
 Date: 4/3/12
 Interchange: I-26 & US 25 Hendersonville

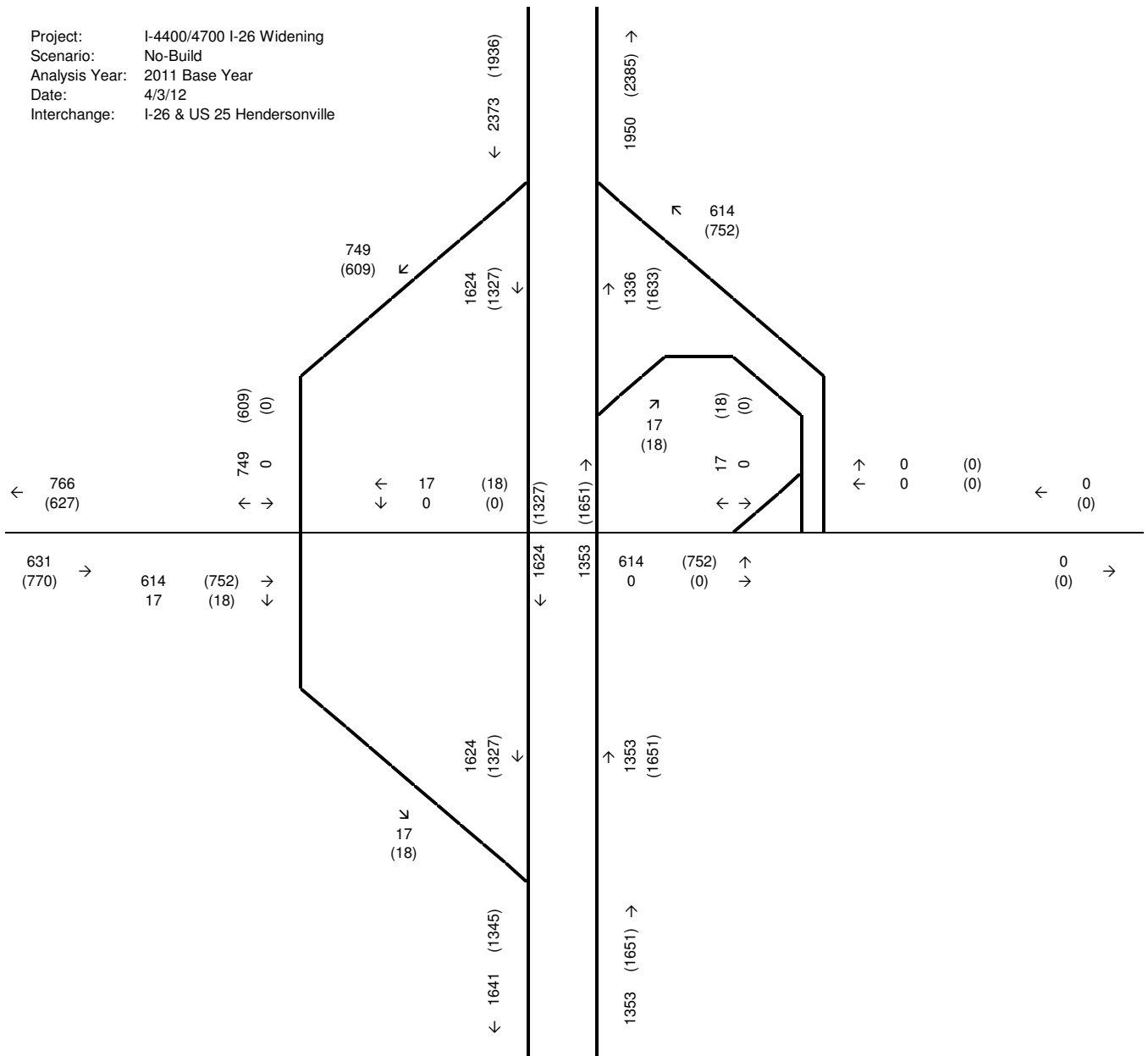

Project: I-4400/4700 I-26 Widening
 Scenario: Build - 6 Lane
 Analysis Year: 2011 Base Year
 Date: 4/3/12
 Interchange: I-26 & US 25 Hendersonville

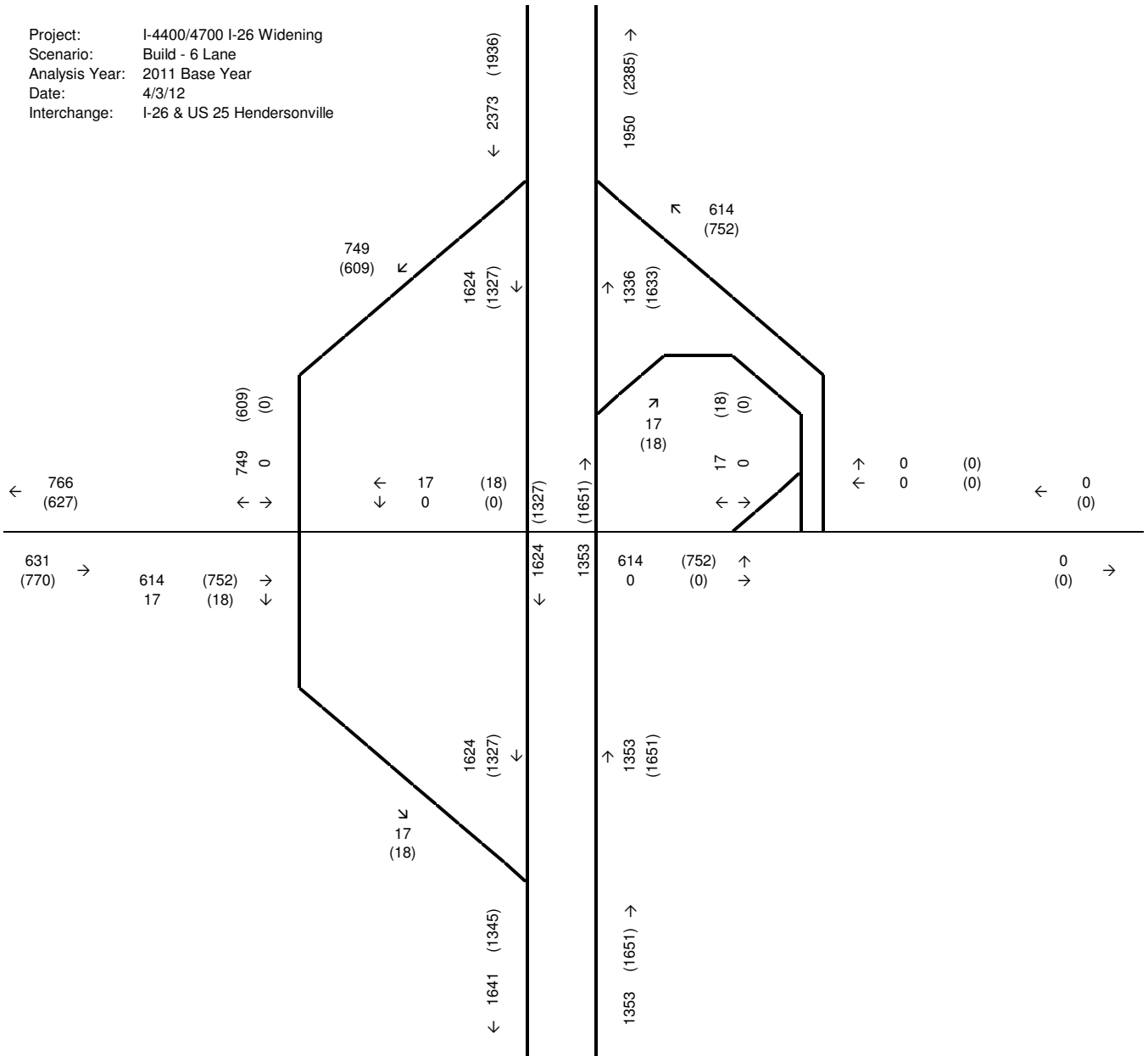

Project: I-4400/4700 I-26 Widening
 Scenario: Build - 8 Lane
 Analysis Year: 2011 Base Year
 Date: 4/3/12
 Interchange: I-26 & US 25 Hendersonville

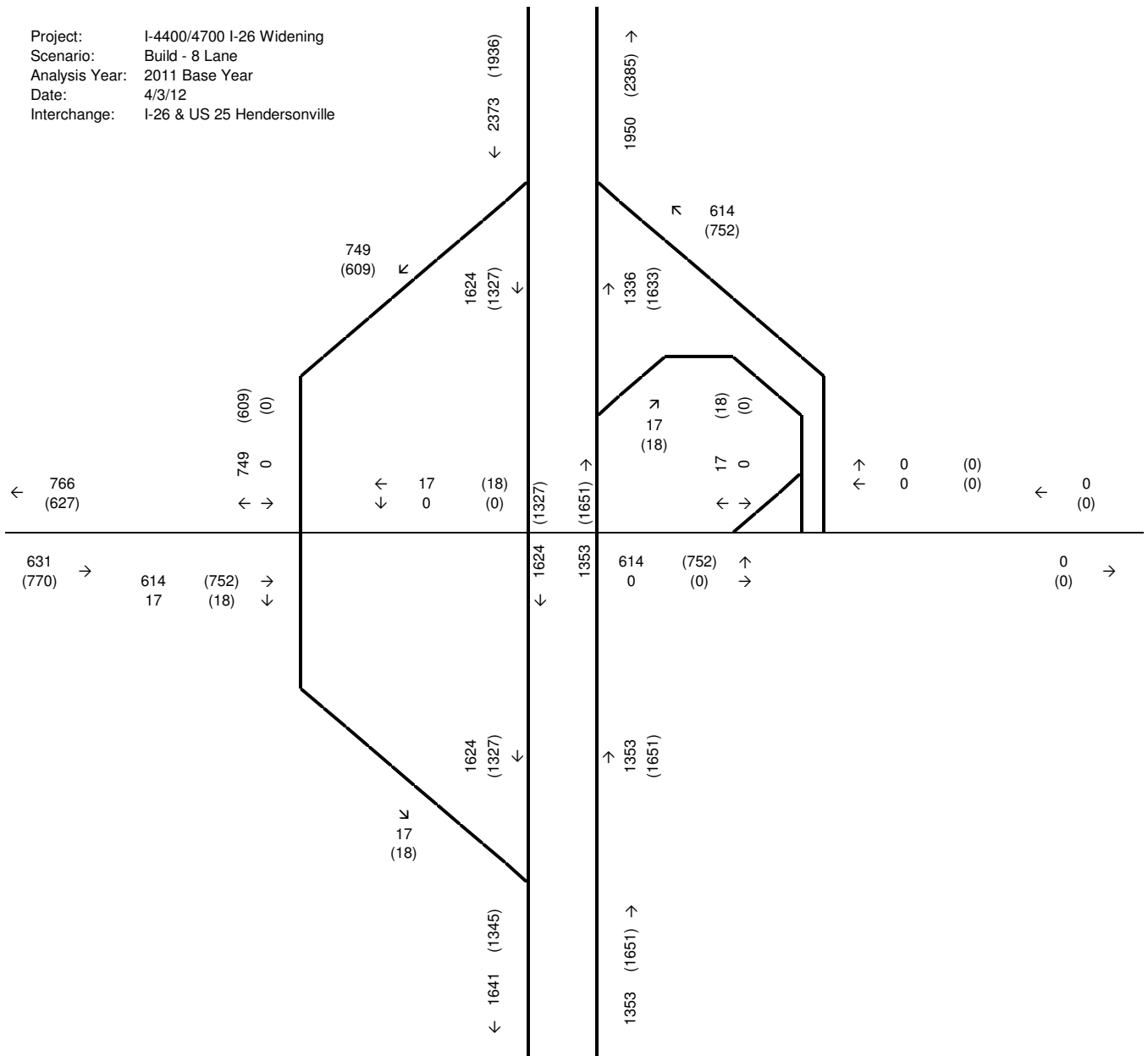

Project: I-4400/4700 I-26 Widening
 Scenario: No-Build
 Analysis Year: 2040 Design Year
 Date: 4/3/12
 Interchange: I-26 & US 25 Hendersonville

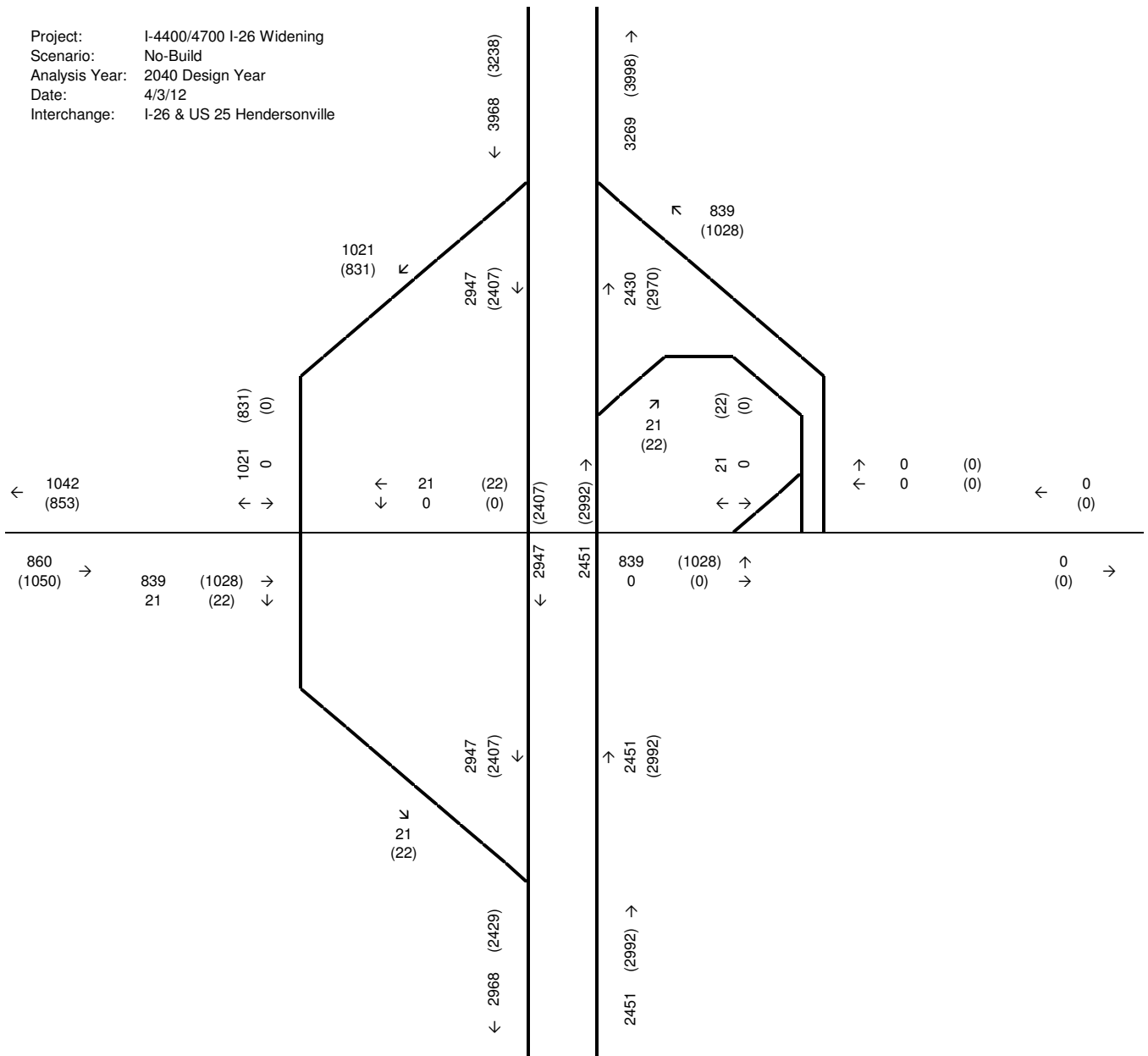

Project: I-4400/4700 I-26 Widening
 Scenario: Build - 6 Lane
 Analysis Year: 2040 Design Year
 Date: 4/3/12
 Interchange: I-26 & US 25 Hendersonville

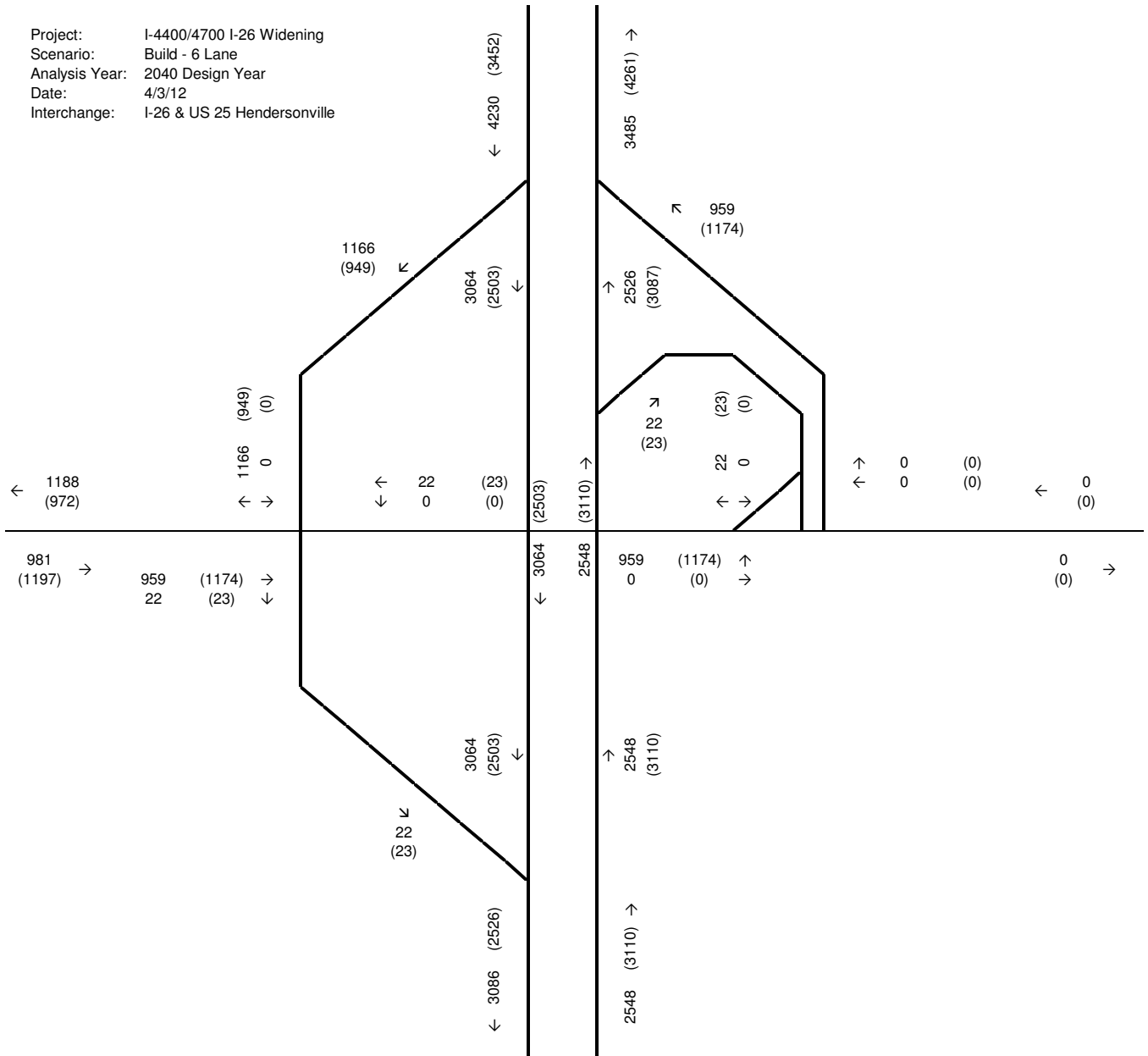

Project: I-4400/4700 I-26 Widening
 Scenario: Build - 8 Lane
 Analysis Year: 2040 Design Year
 Date: 4/3/12
 Interchange: I-26 & US 25 Hendersonville

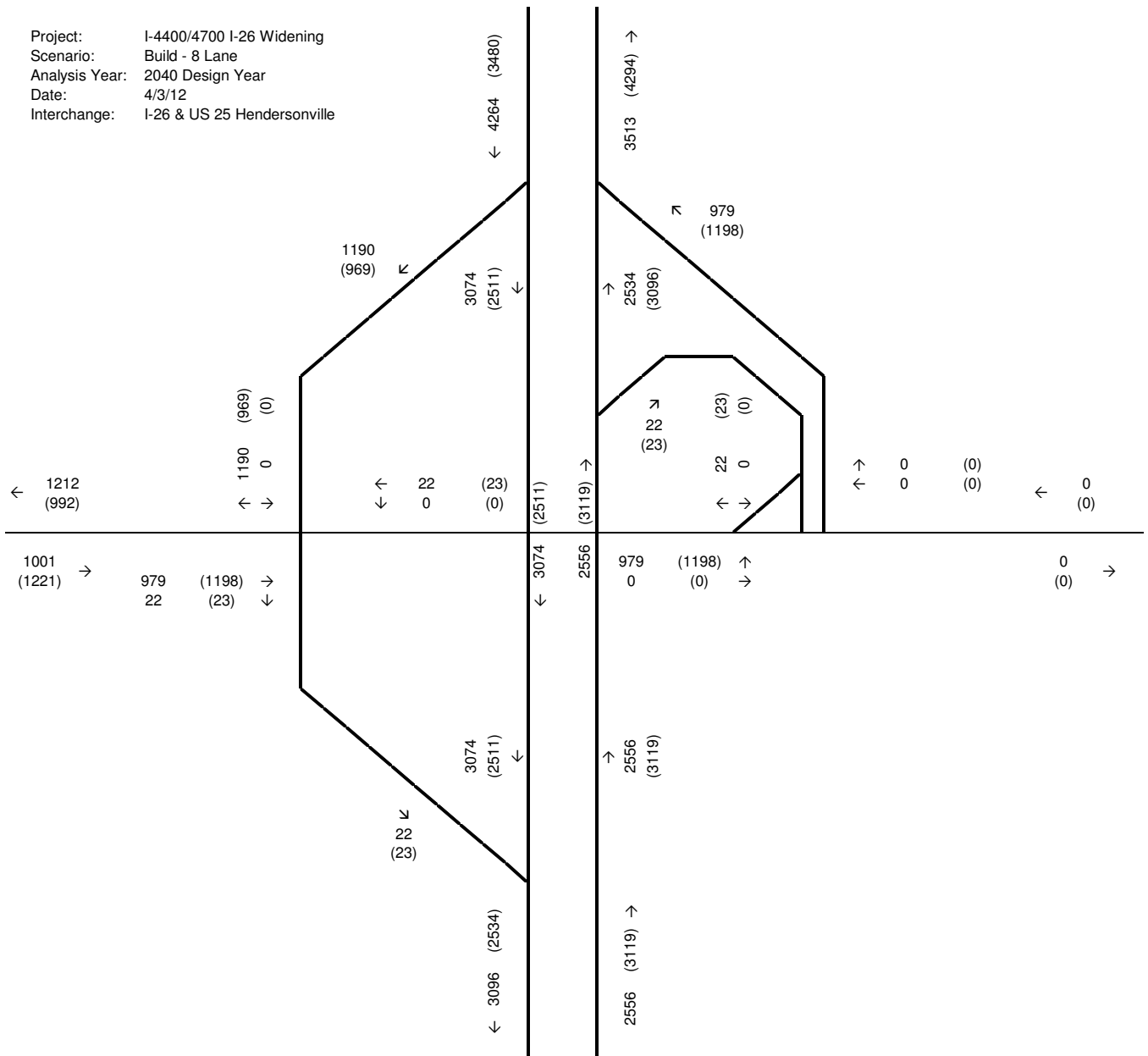

Project: I-4400/4700 I-26 Widening
 Scenario: No-Build
 Analysis Year: 2011 Base Year
 Date: 4/2/12
 Interchange: I-26 & SR 1142 Holbert Cove

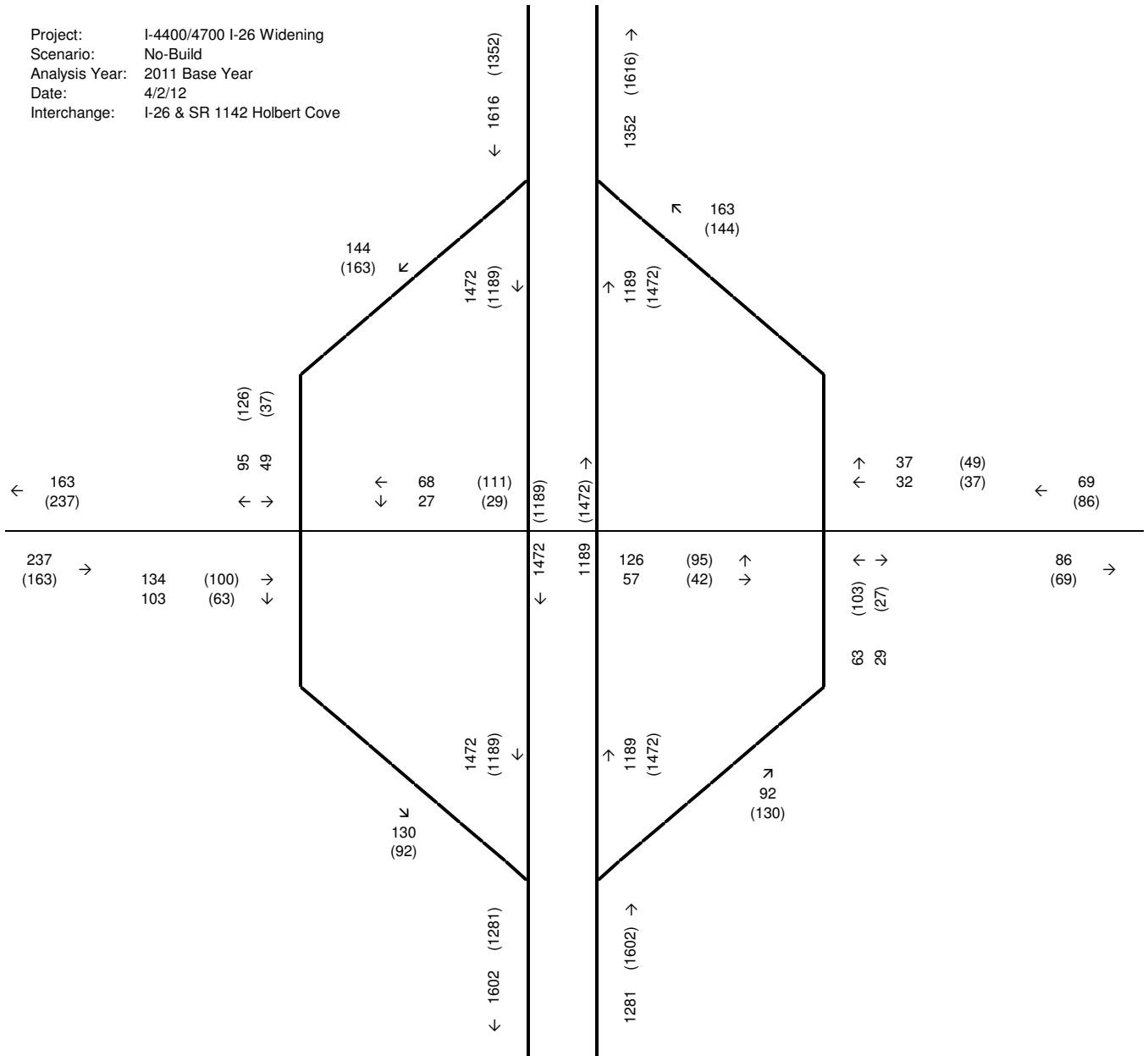

Project: I-4400/4700 I-26 Widening
 Scenario: Build - 6 Lane
 Analysis Year: 2011 Base Year
 Date: 4/2/12
 Interchange: I-26 & SR 1142 Holbert Cove

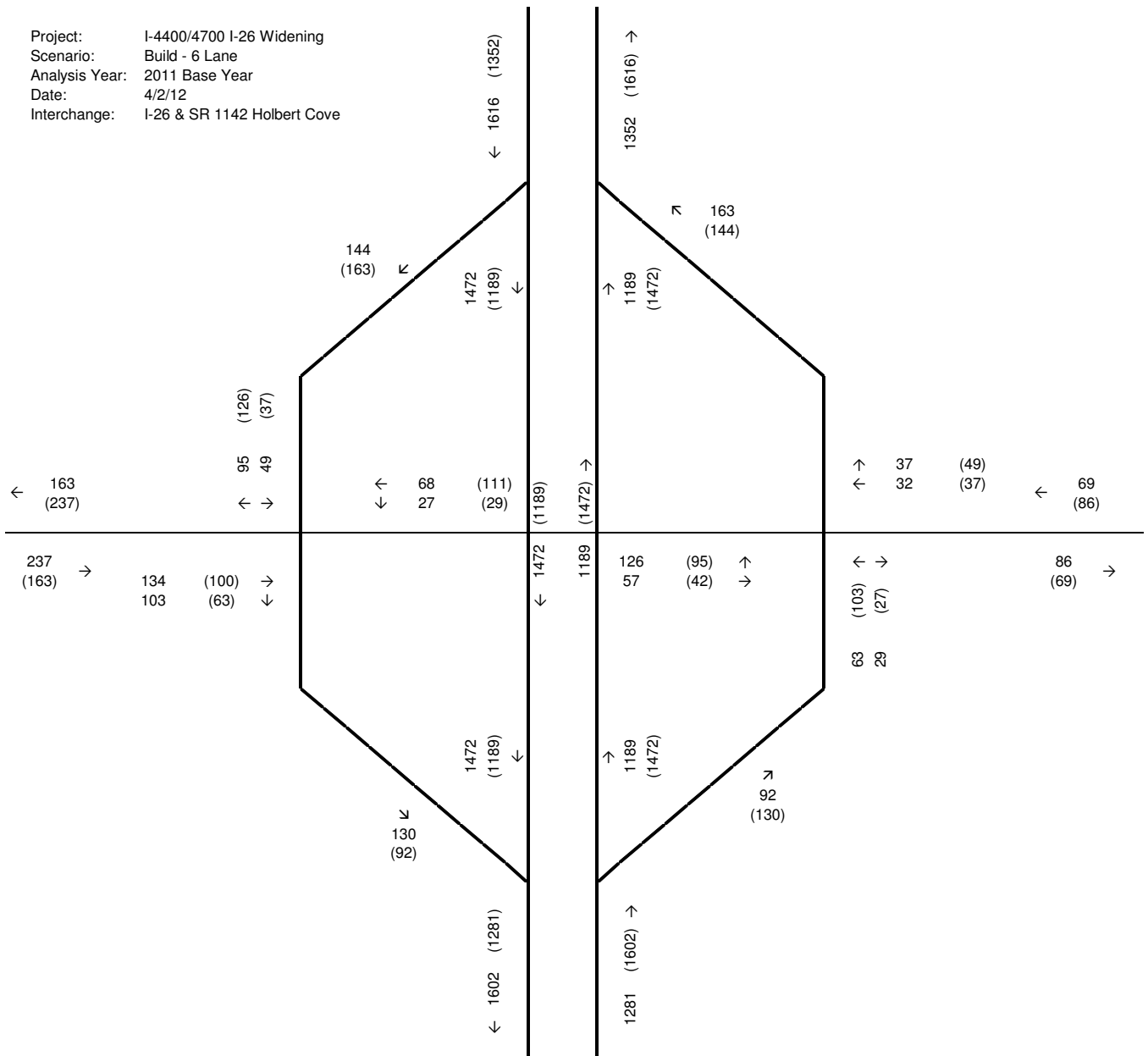

Project: I-4400/4700 I-26 Widening
 Scenario: Build - 8 Lane
 Analysis Year: 2011 Base Year
 Date: 4/2/12
 Interchange: I-26 & SR 1142 Holbert Cove

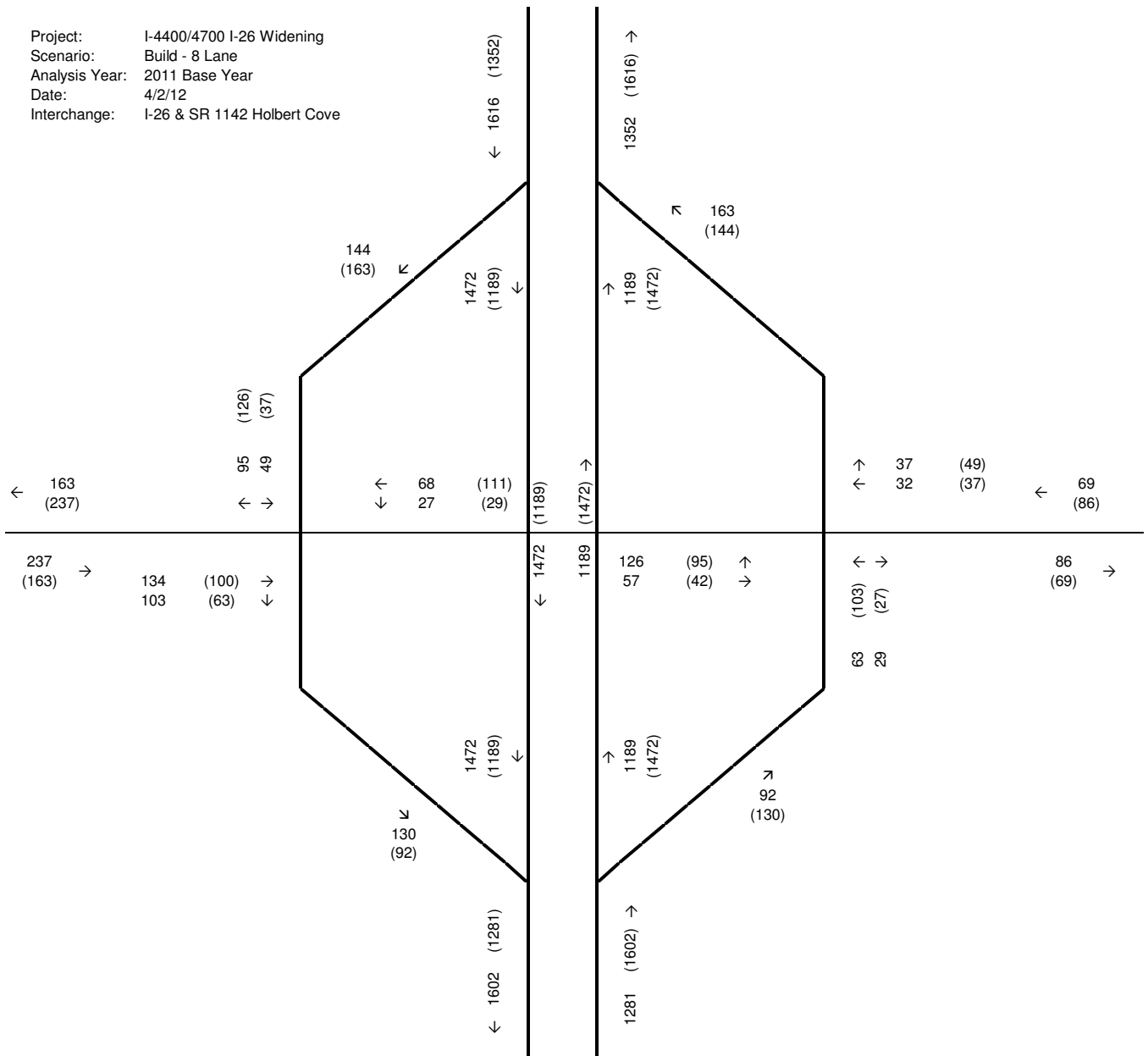

Project: I-4400/4700 I-26 Widening
 Scenario: No-Build
 Analysis Year: 2040 Design Year
 Date: 4/2/12
 Interchange: I-26 & SR 1142 Holbert Cove

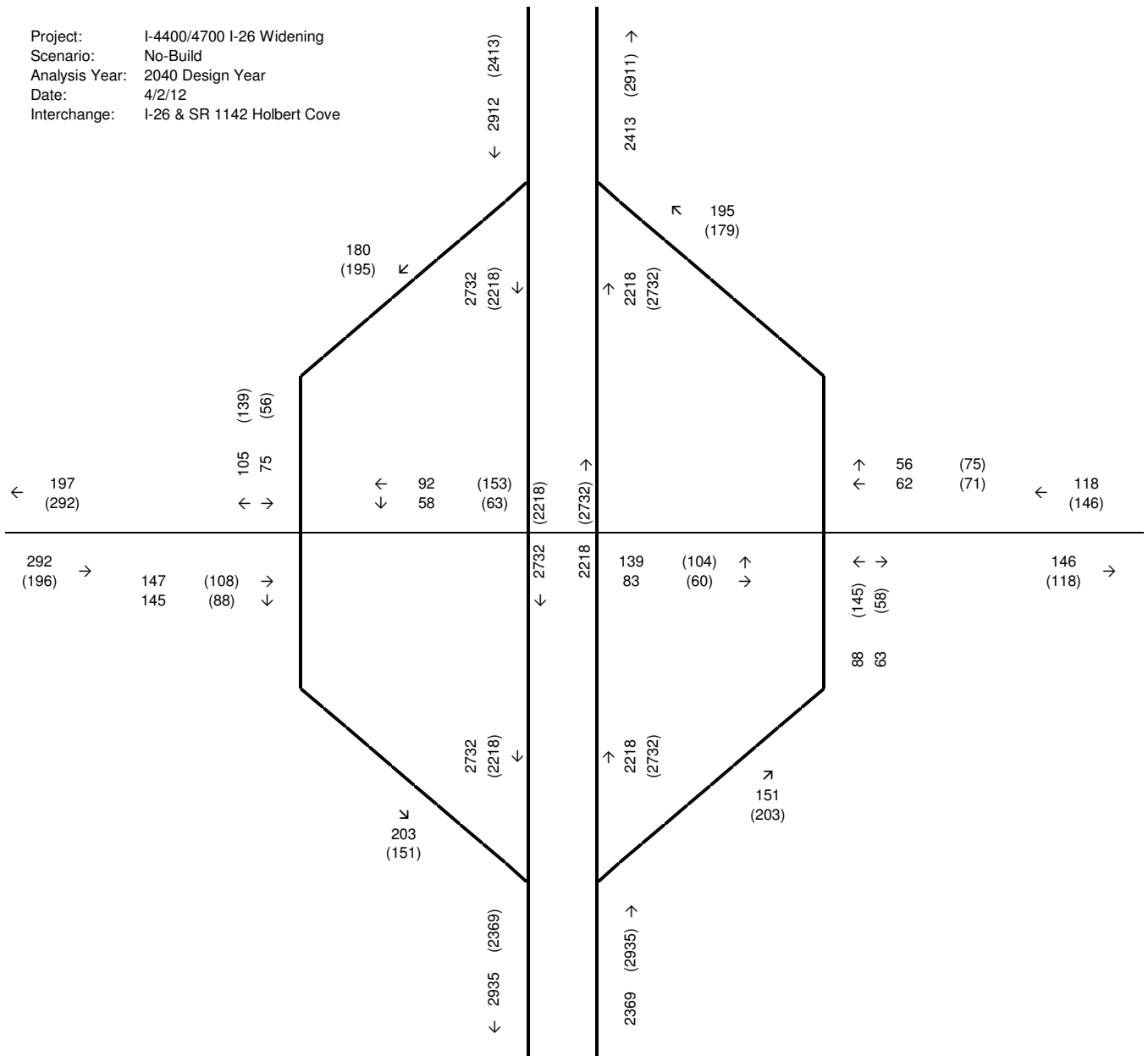

Project: I-4400/4700 I-26 Widening
 Scenario: Build - 6 Lanes
 Analysis Year: 2040 Design Year
 Date: 4/2/12
 Interchange: I-26 & SR 1142 Holbert Cove

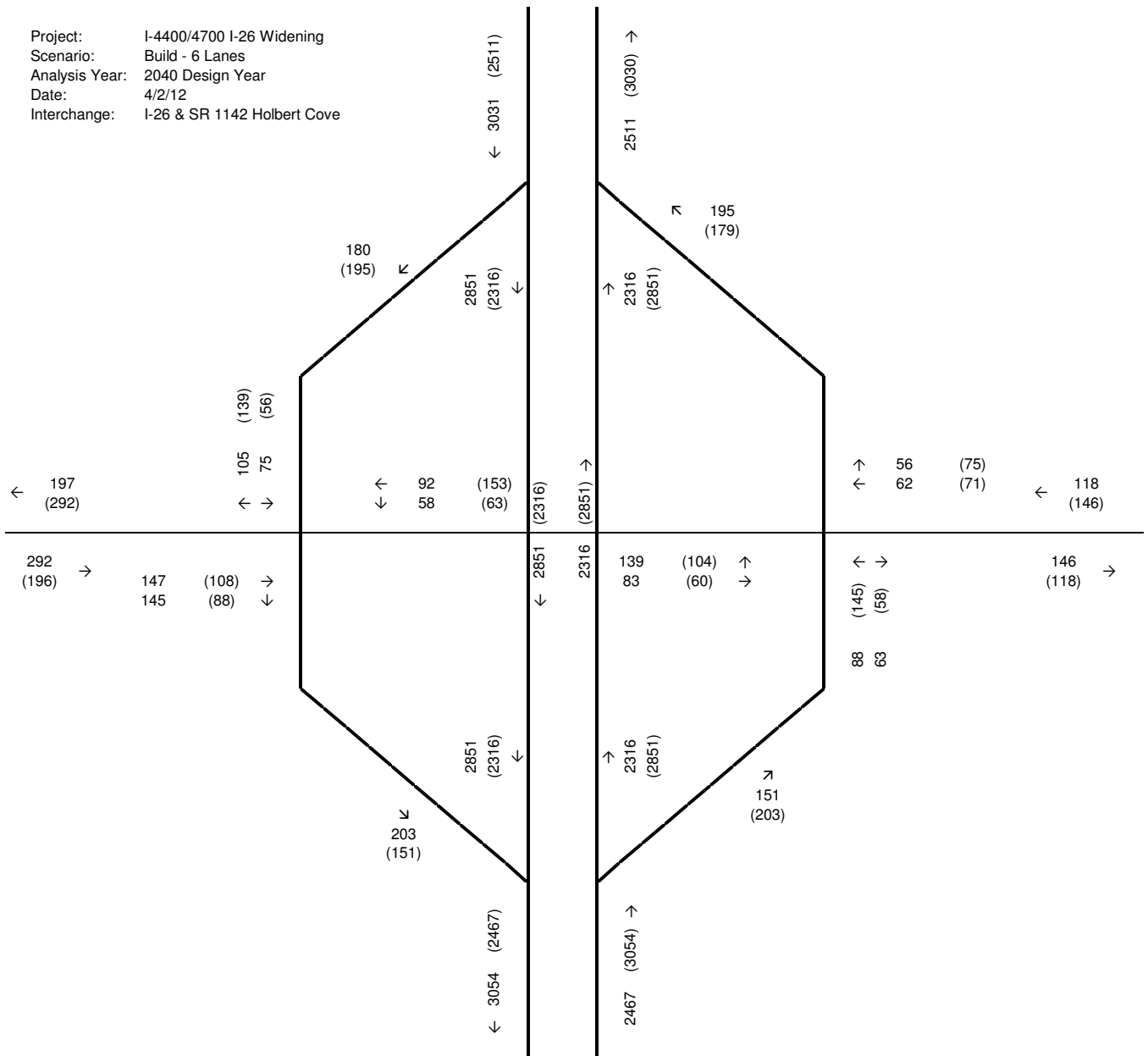

Project: I-4400/4700 I-26 Widening
 Scenario: Build - 8 Lanes
 Analysis Year: 2040 Design Year
 Date: 4/2/12
 Interchange: I-26 & SR 1142 Holbert Cove

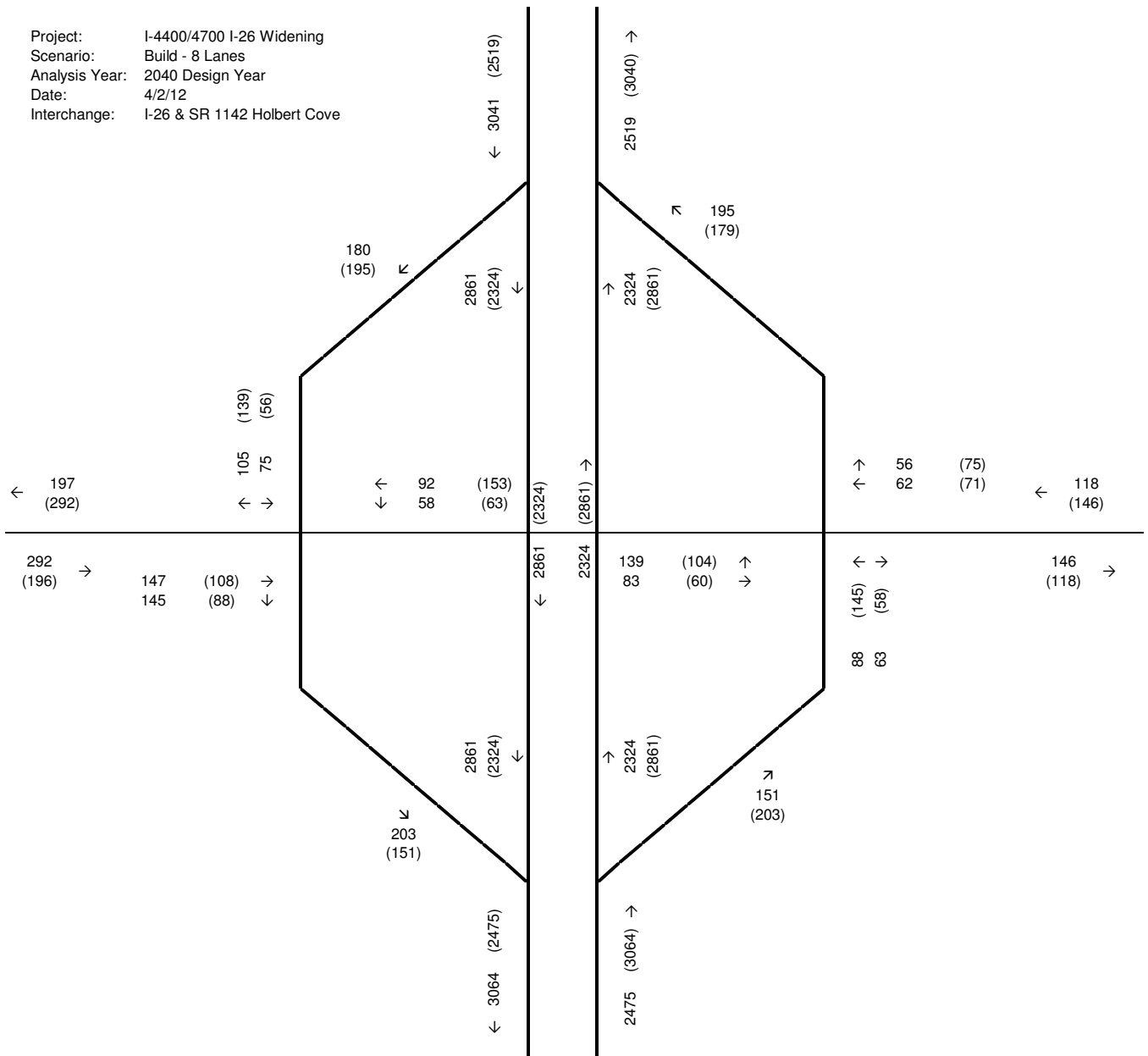

**Interchange 6.
2011 BASE YEAR
NO-BUILD
ALTERNATIVE**

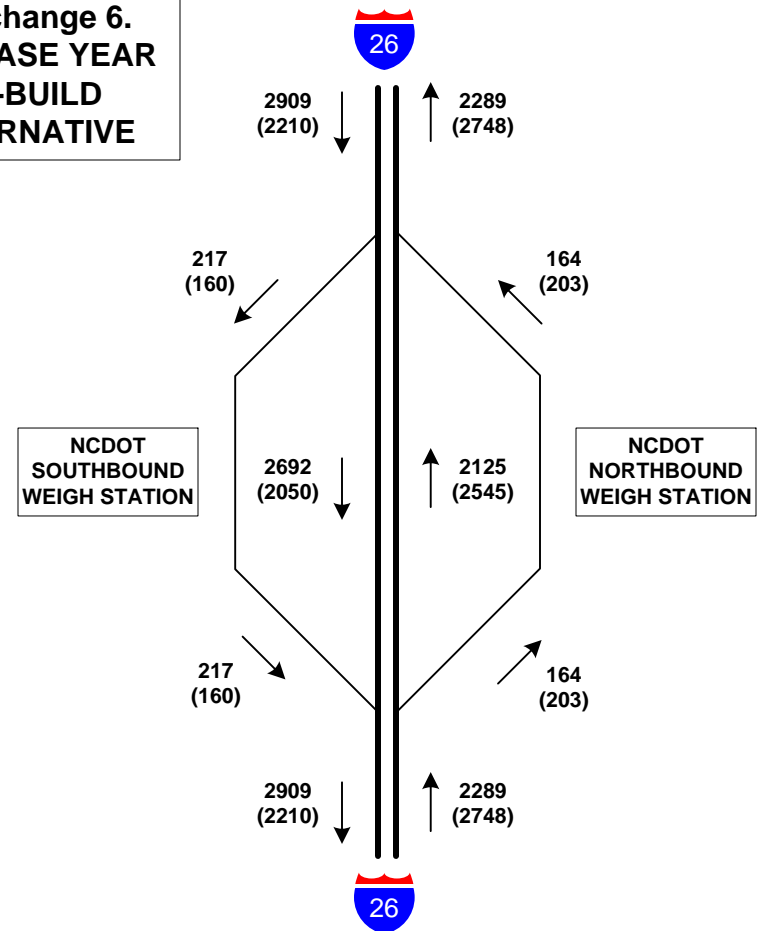

**Interchange 6.
2011 BASE YEAR
BUILD - 6 LANE
ALTERNATIVE**

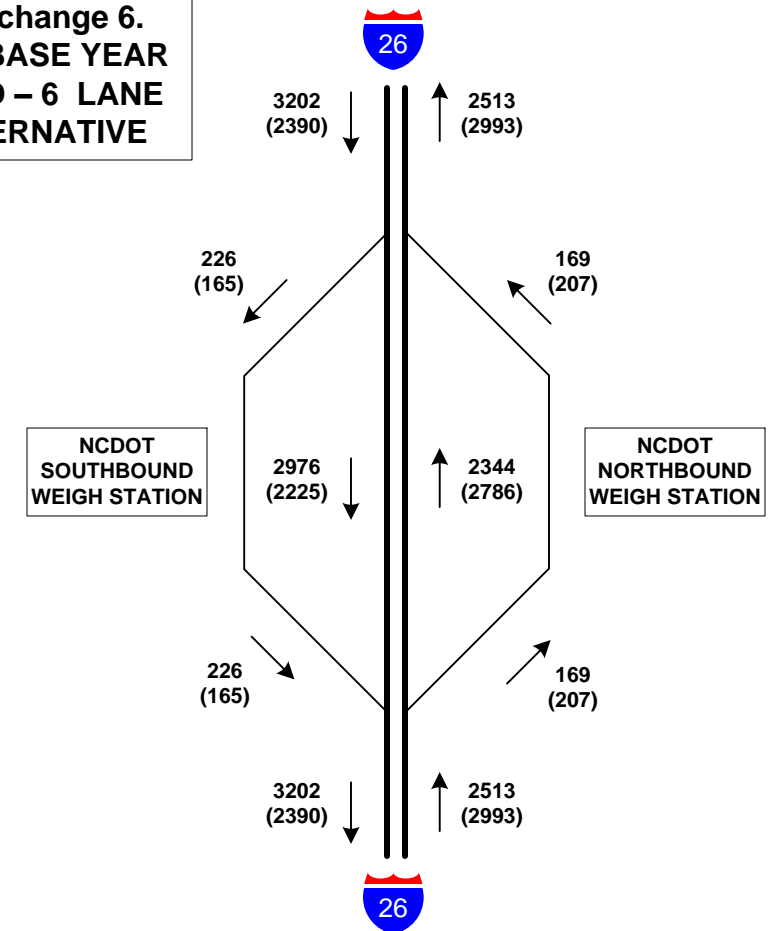

**Interchange 6.
2011 BASE YEAR
BUILD - 8 LANE
ALTERNATIVE**

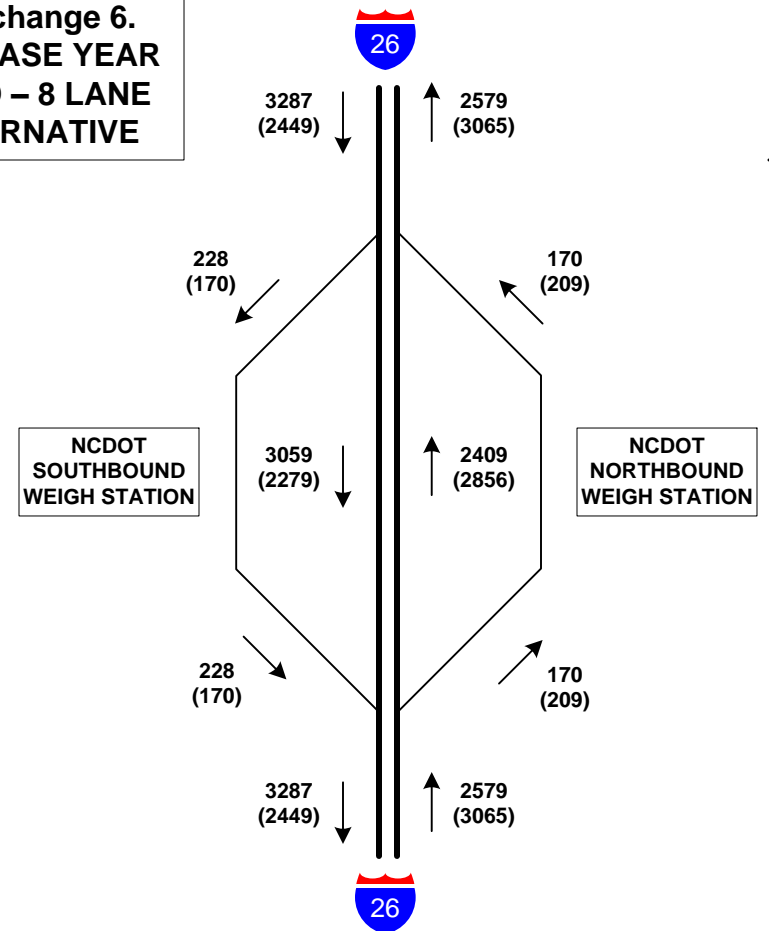

NOT TO SCALE

**Interchange 6.
2040 DESIGN YEAR
NO-BUILD
ALTERNATIVE**

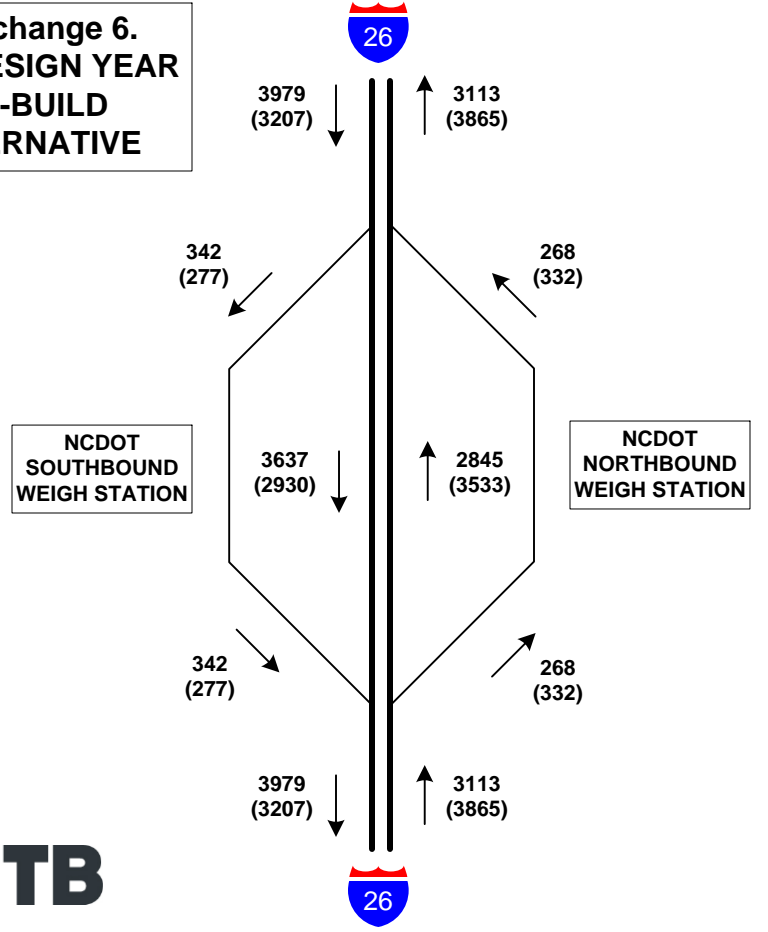

**Interchange 6.
2040 DESIGN YEAR
BUILD - 6 LANE
ALTERNATIVE**

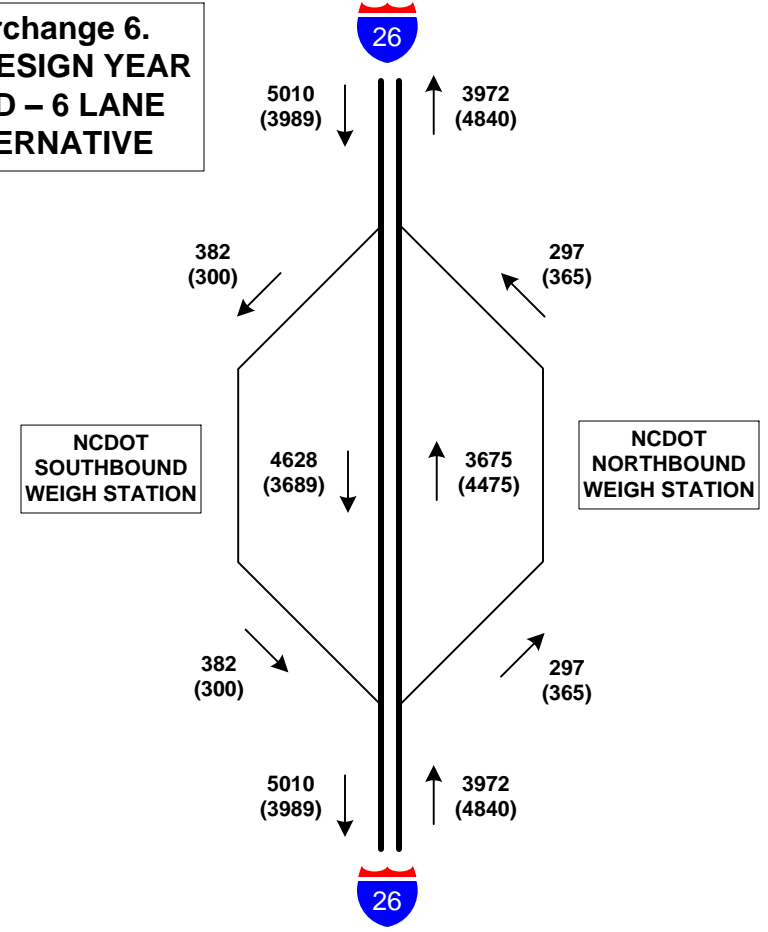

**Interchange 6.
2040 DESIGN YEAR
BUILD - 8 LANE
ALTERNATIVE**

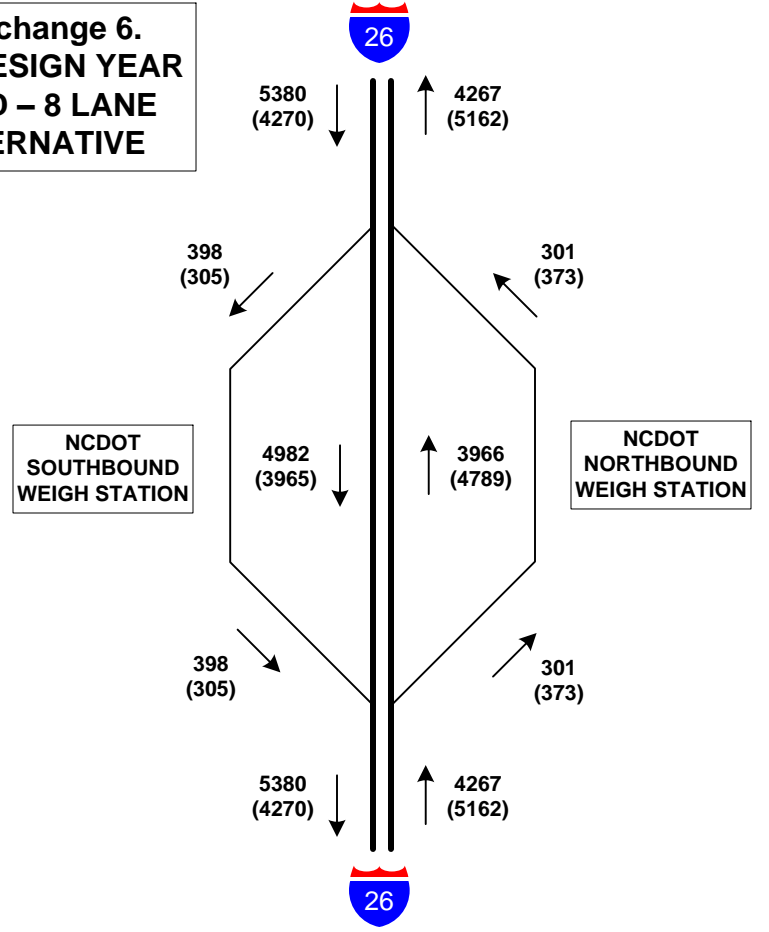

I-26 Widening (STIP Project I-4400/4700)

TRAFFIC FORECAST - PEAK HOUR BREAKOUTS

DATE:
July 2013

FIGURE G-2



**Interchange 4.
2011 BASE YEAR
NO-BUILD
ALTERNATIVE**

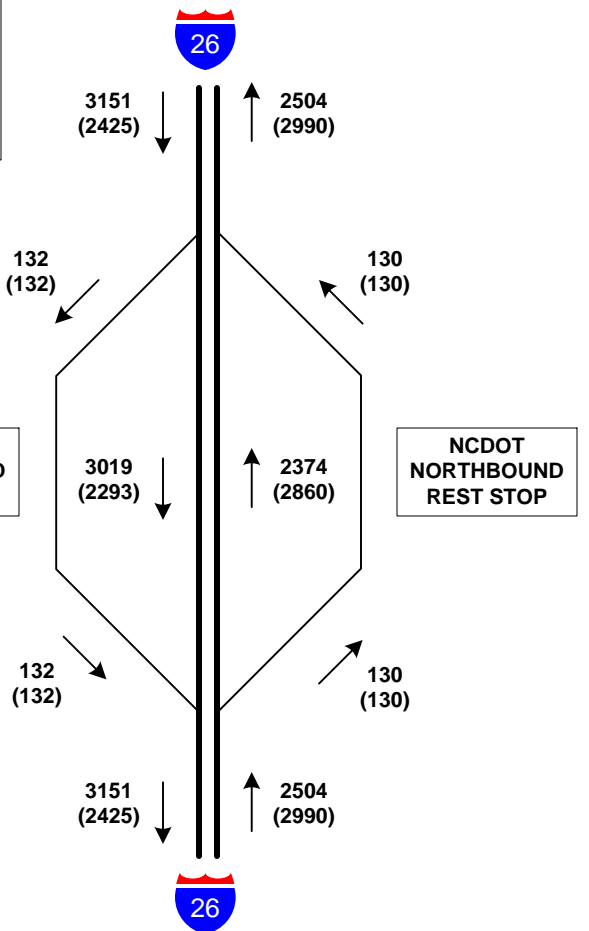

**Interchange 4.
2011 BASE YEAR
BUILD - 6 LANE
ALTERNATIVE**

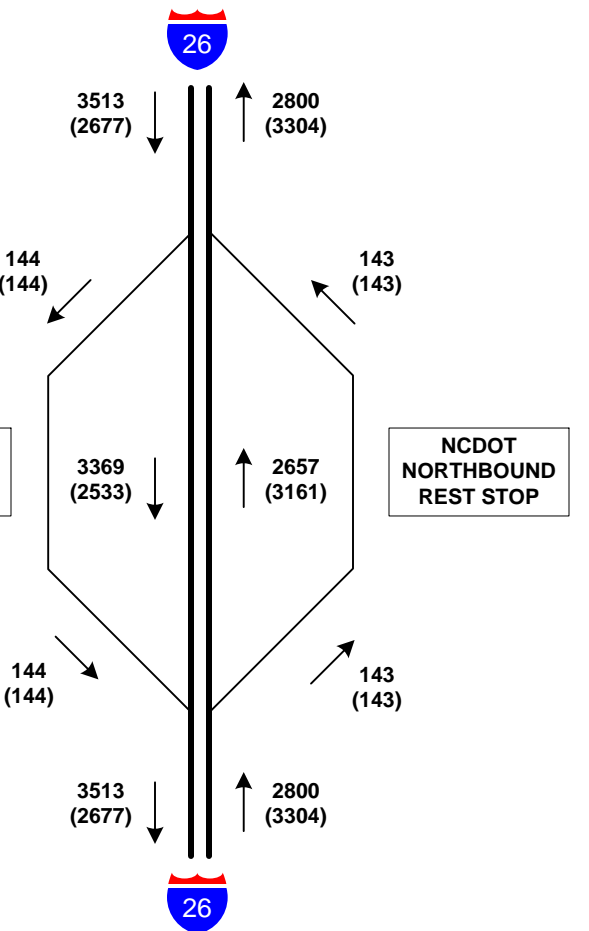

**Interchange 4.
2011 BASE YEAR
BUILD - 8 LANE
ALTERNATIVE**

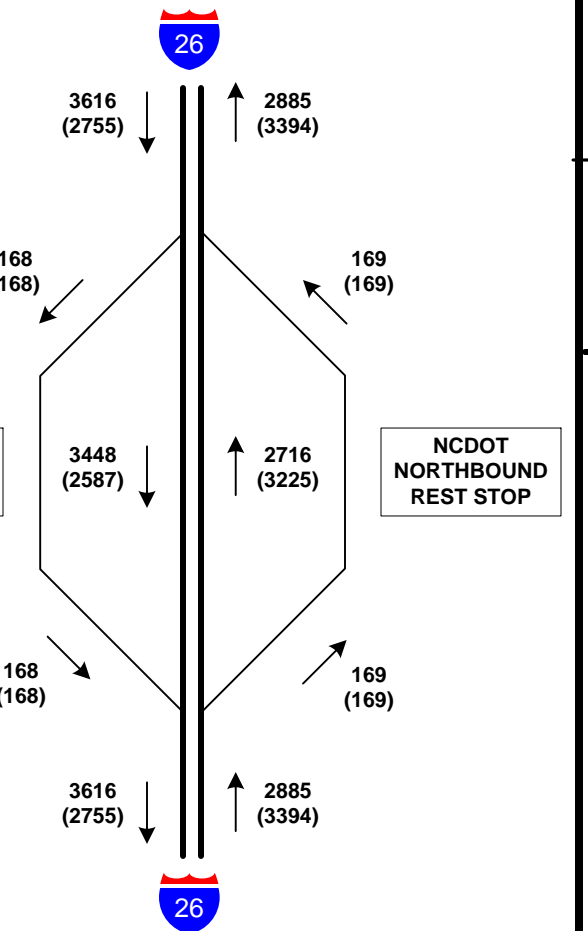

NOT TO SCALE

**Interchange 4.
2040 DESIGN YEAR
NO-BUILD
ALTERNATIVE**

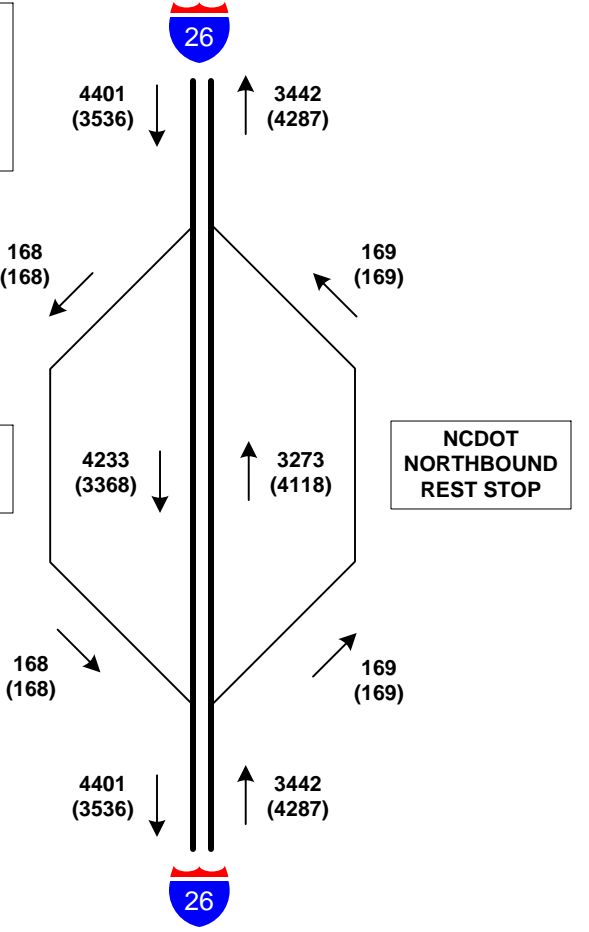

**Interchange 4.
2040 DESIGN YEAR
BUILD - 6 LANE
ALTERNATIVE**

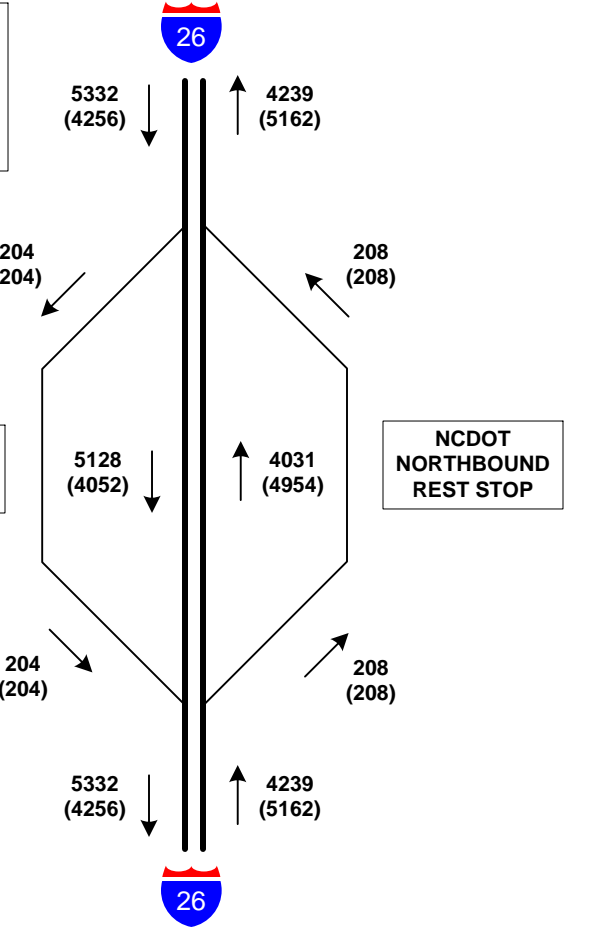

**Interchange 4.
2040 DESIGN YEAR
BUILD - 8 LANE
ALTERNATIVE**

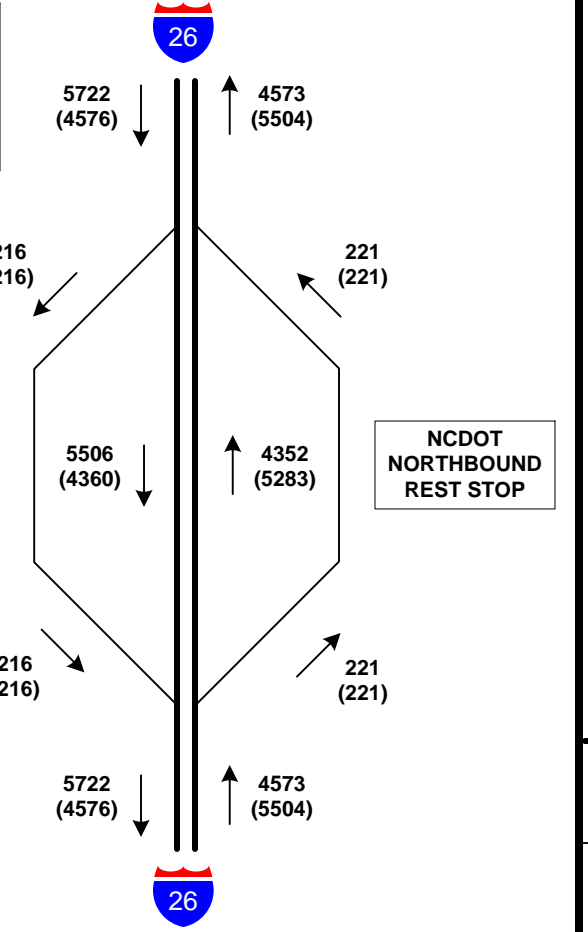

I-26 Widening (STIP Project I-4400/4700)

TRAFFIC FORECAST - PEAK HOUR BREAKOUTS

DATE:
July 2013

FIGURE G-1



Appendix H – Crash Data



STATE OF NORTH CAROLINA
DEPARTMENT OF TRANSPORTATION

BEVERLY EAVES PERDUE
GOVERNOR

EUGENE A. CONTI, JR.
SECRETARY

August 31, 2012

TO: Elise K. Groundwater
Congestion Management Section

FROM: Tammy A. Germiller *Tag*
Traffic Safety Unit

SUBJECT: Safety review for TIP I-4400/I-4700
I-26 from I-40 in Buncombe County through Henderson County to SR 1142 (Holbert Cove Rd) in Polk County

We are providing these comments as part of a safety review for the above referenced project. The crash analysis consisted of a 30.36-mile section of I-26 from I-40 in Buncombe County through Henderson County to SR 1142 (Holbert Cove Rd) in Polk County, which constitutes the approximate project area. There were 1,006 reported crashes along this segment from July 1, 2009 to June 31, 2012 (attached). For crash rate purposes this location can be classified as an Interstate. Table 1 shows the comparison of the crash rates for the analyzed section of I-26 versus the 2008-2010 statewide and the calculated critical rates with a 95% level of confidence for a comparable route type and configuration. **Current crash rates exceed the statewide crash rates in the fatal category only and do not exceed the critical crash rates in any categories.**

Table 1 Crash Rate Comparisons I-26

Rate	Crashes	Crashes per 100MVM	Statewide Rate ¹	Critical Rate ²
Total	1006	52.13	78.21	81.55
Fatal	9	.47	.43	0.70
Non-Fatal Injury	265	13.73	21.69	23.46
Night	248	12.85	22.26	24.05
Wet	201	10.41	20.08	21.78

¹ 2008-2010 statewide crash rate for all Interstates.

² Based on the statewide crash rate (95% level of confidence).

If you have any questions, or if you need further information, please contact Tammy Germiller at tgermiller@ncdot.gov or call (919) 773-2800.

TAG/tag

Attachments (2)

cc: D.D. Galloway, PE
A.G. Henderson, PE
S.E. Cook
T.M. Hopkins, PE
B.K. Mayhew, PE
J.S. Bourne, PE

**North Carolina Department of Transportation
Traffic Engineering Accident Analysis System
Strip Analysis Report**

Study Criteria Summary

County: BUNCOMBE **City:** All and Rural
Date: 8/1/2009 **to** 7/31/2012 **Study:** I4400UPDATE
Location: I-26-US 74 from I-40 interchange in Buncombe County through Henderson County to SR 1142-Holbert Cove Rd in Polk County

Report Details

Acc No	Crash ID	Milepost	Date	Accident Type	Total Damage	Injuries				Condition			Road		Trfc Ctl	
						F	A	B	C	R	L	W	Ch	Ci	Dv	Op
1	103346360	18.959	12/05/2011 19:37	SIDESWIPE, SAME DIRECTION	\$ 1000	0	0	0	0	2	5	3	1	12	0	2
Unit	1 : 32	Alchl/Drgs:	7	Speed: 35 MPH	Dir: E	Veh Mnvr/Ped Actn: 5				Obj Strk:						
Unit	2 : 1	Alchl/Drgs:	0	Speed: 45 MPH	Dir: E	Veh Mnvr/Ped Actn: 4				Obj Strk:						

2	103032037	18.965	11/18/2010 10:07	RAN OFF ROAD - RIGHT	\$ 3000	0	0	0	1	1	1	1	5	0		
Unit	1 : 1	Alchl/Drgs:	0	Speed: 55 MPH	Dir: SW	Veh Mnvr/Ped Actn: 4				Obj Strk: 42						

3	102789500	18.988	01/26/2010 07:59	REAR END, SLOW OR STOP	\$ 6000	0	0	0	0	2	1	2	1	0	14	1
Unit	1 : 4	Alchl/Drgs:	0	Speed: 45 MPH	Dir: W	Veh Mnvr/Ped Actn: 4				Obj Strk:						
Unit	2 : 4	Alchl/Drgs:	0	Speed: 45 MPH	Dir: W	Veh Mnvr/Ped Actn: 4				Obj Strk:						

4	103502976	19.007	07/11/2012 16:20	RAN OFF ROAD - LEFT	\$ 5000	0	0	0	0	2	1	3	5	0		
Unit	1 : 3	Alchl/Drgs:	0	Speed: 65 MPH	Dir: E	Veh Mnvr/Ped Actn: 4				Obj Strk:						

5	103162626	19.010	05/12/2011 15:06	RAN OFF ROAD - RIGHT	\$ 9000	0	0	0	1	1	1	2	1	0		1
Unit	1 : 1	Alchl/Drgs:	0	Speed: 60 MPH	Dir: N	Veh Mnvr/Ped Actn: 4				Obj Strk: 59						

6	102894961	19.050	06/08/2010 16:32	SIDESWIPE, SAME DIRECTION	\$ 2000	0	0	0	0	1	1	1	5	0		2
Unit	1 : 1	Alchl/Drgs:	0	Speed: 55 MPH	Dir: E	Veh Mnvr/Ped Actn: 5				Obj Strk:						
Unit	2 : 1	Alchl/Drgs:	0	Speed: 55 MPH	Dir: E	Veh Mnvr/Ped Actn: 5				Obj Strk:						

7	103106332	19.050	02/25/2011 10:45	REAR END, SLOW OR STOP	\$ 3800	0	0	0	0	1	1	1	1	0	0	
Unit	1 : 14	Alchl/Drgs:	0	Speed: 55 MPH	Dir: E	Veh Mnvr/Ped Actn: 11				Obj Strk:						
Unit	2 : 1	Alchl/Drgs:	0	Speed: 0 MPH	Dir: E	Veh Mnvr/Ped Actn: 1				Obj Strk:						

8	103382120	19.050	01/27/2012 16:30	FIXED OBJECT	\$ 15000	0	0	1	0	1	1	1	1	0		2
Unit	1 : 2	Alchl/Drgs:	1	Speed: 80 MPH	Dir: S	Veh Mnvr/Ped Actn: 6				Obj Strk: 41						

9	103425156	19.050	03/30/2012 22:00	RAN OFF ROAD - RIGHT	\$ 7000	0	0	0	0	2	5	3	1	0		2
Unit	1 : 4	Alchl/Drgs:	0	Speed: 60 MPH	Dir: E	Veh Mnvr/Ped Actn: 4				Obj Strk: 42						

**North Carolina Department of Transportation
Traffic Engineering Accident Analysis System
Strip Analysis Report**

Acc No	Crash ID	Milepost	Date	Accident Type	Total Damage	Injuries				Condition			Road		Trfc Ctl			
						F	A	B	C	R	L	W	Ch	Ci	Dv	Op		
10	103483107	19.050	06/13/2012 06:42	SIDESWIPE, SAME DIRECTION	\$ 1000	0	0	0	0	1	1	1	1	1	0			
Unit	1 : 1	Alchl/Drgs:	0	Speed: 60 MPH Dir: E		Veh Mnvr/Ped Actn:				6	Obj Strk:							
Unit	2 : 1	Alchl/Drgs:	0	Speed: 60 MPH Dir: E		Veh Mnvr/Ped Actn:				4	Obj Strk:							
11	102683889	19.150	09/17/2009 08:10	REAR END, SLOW OR STOP	\$ 7000	0	0	1	1	2	1	3	1	0			2	
Unit	1 : 4	Alchl/Drgs:	0	Speed: 55 MPH Dir: E		Veh Mnvr/Ped Actn:				4	Obj Strk:							
Unit	2 : 2	Alchl/Drgs:	0	Speed: 0 MPH Dir: E		Veh Mnvr/Ped Actn:				1	Obj Strk:							
12	102705375	19.150	09/26/2009 05:56	RAN OFF ROAD - RIGHT	\$ 35000	0	0	1	0	2	5	3	5	0				
Unit	1 : 10	Alchl/Drgs:	0	Speed: 55 MPH Dir: E		Veh Mnvr/Ped Actn:				16	Obj Strk:						42	
13	102698879	19.150	10/05/2009 20:01	SIDESWIPE, SAME DIRECTION	\$ 300	0	0	0	0	1	4	1	5	0	0	0	2	
Unit	1 : 14	Alchl/Drgs:	0	Speed: 50 MPH Dir: E		Veh Mnvr/Ped Actn:				4	Obj Strk:							
Unit	2 : 1	Alchl/Drgs:	0	Speed: 40 MPH Dir: E		Veh Mnvr/Ped Actn:				5	Obj Strk:							
14	103316308	19.150	10/22/2011 16:46	REAR END, SLOW OR STOP	\$ 1700	0	0	0	0	1	1	1	1	0			2	
Unit	1 : 1	Alchl/Drgs:	0	Speed: 25 MPH Dir: E		Veh Mnvr/Ped Actn:				4	Obj Strk:							
Unit	2 : 1	Alchl/Drgs:	0	Speed: 15 MPH Dir: E		Veh Mnvr/Ped Actn:				11	Obj Strk:							
15	103429664	19.190	04/03/2012 12:01	SIDESWIPE, SAME DIRECTION	\$ 3500	0	0	0	0	1	1	1	1	0				
Unit	1 : 1	Alchl/Drgs:	0	Speed: 55 MPH Dir: N		Veh Mnvr/Ped Actn:				5	Obj Strk:							
Unit	2 : 2	Alchl/Drgs:	0	Speed: 55 MPH Dir: N		Veh Mnvr/Ped Actn:				4	Obj Strk:						42	
16	102800065	19.200	02/03/2010 14:19	ANIMAL	\$ 8200	0	0	0	0	1	1	1	1	0	10	1		
Unit	1 : 2	Alchl/Drgs:	0	Speed: 50 MPH Dir: W		Veh Mnvr/Ped Actn:				16	Obj Strk:						38	
17	102988220	19.200	10/11/2010 13:58	RAN OFF ROAD - RIGHT	\$ 250	0	0	1	1	1	1	1	1	0	0			
Unit	1 : 20	Alchl/Drgs:	0	Speed: 25 MPH Dir: NW		Veh Mnvr/Ped Actn:				4	Obj Strk:							
18	103197337	19.250	06/20/2011 07:53	RAN OFF ROAD - LEFT	\$ 4500	0	0	0	0	2	3	3	2	0	0			
Unit	1 : 1	Alchl/Drgs:	0	Speed: 55 MPH Dir: E		Veh Mnvr/Ped Actn:				4	Obj Strk:						42	
19	103219739	19.250	07/23/2011 13:01	REAR END, SLOW OR STOP	\$ 4500	0	0	0	0	1	1	1	1	0			2	
Unit	1 : 1	Alchl/Drgs:	0	Speed: 45 MPH Dir: E		Veh Mnvr/Ped Actn:				4	Obj Strk:							
Unit	2 : 4	Alchl/Drgs:	0	Speed: 15 MPH Dir: E		Veh Mnvr/Ped Actn:				11	Obj Strk:							

**North Carolina Department of Transportation
Traffic Engineering Accident Analysis System
Strip Analysis Report**

Acc No	Crash ID	Milepost	Date	Accident Type	Total Damage	Injuries				Condition			Road		Trfc Ctl	
						F	A	B	C	R	L	W	Ch	Ci	Dv	Op
20	103499265	19.250	07/14/2012 14:03	SIDESWIPE, SAME DIRECTION	\$ 150	0	0	0	0	1	1	1	5	0	0	
Unit	1 : 1	Alchl/Drgs:	0	Speed: 55 MPH Dir: E		Veh Mnvr/Ped Actn:				4	Obj Strk:					
Unit	2 : 2	Alchl/Drgs:	0	Speed: 55 MPH Dir: E		Veh Mnvr/Ped Actn:				4	Obj Strk:					
21	102708121	19.300	10/15/2009 16:04	SIDESWIPE, SAME DIRECTION	\$ 2100	0	0	0	0	1	1	2	1	0	2	
Unit	1 : 10	Alchl/Drgs:	0	Speed: 40 MPH Dir: E		Veh Mnvr/Ped Actn:				5	Obj Strk:					
Unit	2 : 1	Alchl/Drgs:	0	Speed: 40 MPH Dir: E		Veh Mnvr/Ped Actn:				4	Obj Strk:					
22	102950515	19.393	08/21/2010 15:34	REAR END, SLOW OR STOP	\$ 3000	0	0	0	1	2	1	3	1	0	0	2
Unit	1 : 1	Alchl/Drgs:	0	Speed: 45 MPH Dir: W		Veh Mnvr/Ped Actn:				4	Obj Strk:					
Unit	2 : 1	Alchl/Drgs:	0	Speed: 0 MPH Dir: W		Veh Mnvr/Ped Actn:				1	Obj Strk:					
23	102850417	19.400	04/13/2010 17:22	ANGLE	\$ 1000	0	0	0	0	1	1	1	1	0	2	
Unit	1 : 2	Alchl/Drgs:	0	Speed: 20 MPH Dir: E		Veh Mnvr/Ped Actn:				5	Obj Strk:					
Unit	2 : 1	Alchl/Drgs:	0	Speed: 20 MPH Dir: E		Veh Mnvr/Ped Actn:				4	Obj Strk:					
24	103026612	19.420	10/19/2010 23:45	PEDESTRIAN	\$ 50	0	0	1	0	1	5	1	2	0	0	
Unit	1 : 32	Alchl/Drgs:	7	Speed: 60 MPH Dir: S		Veh Mnvr/Ped Actn:				4	Obj Strk:		14			
Unit	2 : 24	Alchl/Drgs:	0	Speed: 0 MPH Dir:		Veh Mnvr/Ped Actn:					Obj Strk:		14			
25	102863083	19.450	04/29/2010 17:20	REAR END, SLOW OR STOP	\$ 4500	0	0	0	0	1	1	1	1	0	0	
Unit	1 : 5	Alchl/Drgs:	0	Speed: 55 MPH Dir: S		Veh Mnvr/Ped Actn:				11	Obj Strk:					
Unit	2 : 2	Alchl/Drgs:	0	Speed: 55 MPH Dir: S		Veh Mnvr/Ped Actn:				11	Obj Strk:					
26	103035366	19.450	11/30/2010 07:12	RAN OFF ROAD - LEFT	\$ 2000	0	0	0	0	2	1	3	1	0		
Unit	1 : 1	Alchl/Drgs:	0	Speed: 65 MPH Dir: SE		Veh Mnvr/Ped Actn:				4	Obj Strk:		42			
27	103302517	19.450	10/28/2011 06:47	REAR END, SLOW OR STOP	\$ 3600	0	0	0	1	1	4	1	1	0	0	
Unit	1 : 12	Alchl/Drgs:	0	Speed: 30 MPH Dir: E		Veh Mnvr/Ped Actn:				11	Obj Strk:					
Unit	2 : 1	Alchl/Drgs:	0	Speed: 60 MPH Dir: E		Veh Mnvr/Ped Actn:				11	Obj Strk:					
28	103324320	19.450	11/17/2011 06:05	OTHER NON-COLLISION	\$ 800	0	0	0	1	2	4	2	1	0		
Unit	1 : 2	Alchl/Drgs:	0	Speed: 55 MPH Dir: E		Veh Mnvr/Ped Actn:				4	Obj Strk:		44			
29	103324329	19.450	11/17/2011 06:31	SIDESWIPE, SAME DIRECTION	\$ 310	0	0	0	0	2	4	2	1	0	0	
Unit	1 : 12	Alchl/Drgs:	0	Speed: 60 MPH Dir: E		Veh Mnvr/Ped Actn:				5	Obj Strk:					
Unit	2 : 2	Alchl/Drgs:	0	Speed: 60 MPH Dir: E		Veh Mnvr/Ped Actn:				4	Obj Strk:					

**North Carolina Department of Transportation
Traffic Engineering Accident Analysis System
Strip Analysis Report**

Acc No	Crash ID	Milepost	Date	Accident Type	Total Damage	Injuries				Condition			Road		Trfc Ctl	
						F	A	B	C	R	L	W	Ch	Ci	Dv	Op
30	103388471	19.450	02/06/2012 15:08	REAR END, SLOW OR STOP	\$ 3500	0	0	0	0	1	1	1	1	0	0	
Unit	1 : 1	Alchl/Drgs:	0	Speed:	60 MPH Dir: E	Veh Mnvr/Ped Actn:				4	Obj Strk:					
Unit	2 : 4	Alchl/Drgs:	0	Speed:	50 MPH Dir: E	Veh Mnvr/Ped Actn:				4	Obj Strk:					
31	103229786	19.456	08/07/2011 13:26	REAR END, SLOW OR STOP	\$ 12000	0	0	2	2	1	1	1	9	0	2	
Unit	1 : 1	Alchl/Drgs:	0	Speed:	50 MPH Dir: W	Veh Mnvr/Ped Actn:				11	Obj Strk:					
Unit	2 : 1	Alchl/Drgs:	0	Speed:	0 MPH Dir: W	Veh Mnvr/Ped Actn:				1	Obj Strk:					
32	102711532	19.470	10/23/2009 17:13	REAR END, SLOW OR STOP	\$ 7400	0	0	0	0	2	1	3	7	0	0	
Unit	1 : 2	Alchl/Drgs:	0	Speed:	50 MPH Dir: E	Veh Mnvr/Ped Actn:				5	Obj Strk:					
Unit	2 : 1	Alchl/Drgs:	0	Speed:	50 MPH Dir: E	Veh Mnvr/Ped Actn:				11	Obj Strk:					
33	103162663	19.480	05/13/2011 16:20	REAR END, SLOW OR STOP	\$ 12800	0	0	0	2	1	1	1	1	0		
Unit	1 : 1	Alchl/Drgs:	0	Speed:	45 MPH Dir: E	Veh Mnvr/Ped Actn:				4	Obj Strk:					
Unit	2 : 1	Alchl/Drgs:	0	Speed:	45 MPH Dir: E	Veh Mnvr/Ped Actn:				4	Obj Strk:					
Unit	3 : 1	Alchl/Drgs:	0	Speed:	0 MPH Dir: E	Veh Mnvr/Ped Actn:				4	Obj Strk:					
34	103406972	19.500	03/03/2012 12:23	FIXED OBJECT	\$ 5600	0	0	1	0	1	1	1	5	0	0	2
Unit	1 : 2	Alchl/Drgs:	0	Speed:	55 MPH Dir: E	Veh Mnvr/Ped Actn:				16	Obj Strk:		42			
35	102684237	19.510	09/17/2009 07:59	OVERTURN/ROLLOVER	\$ 20000	0	0	0	1	2	1	3	1	1	10	1
Unit	1 : 2	Alchl/Drgs:	0	Speed:	50 MPH Dir: NW	Veh Mnvr/Ped Actn:				4	Obj Strk:		44			
36	102802570	19.510	02/11/2010 16:30	REAR END, SLOW OR STOP	\$ 9000	0	0	0	1	1	1	1	1	0	0	
Unit	1 : 12	Alchl/Drgs:	0	Speed:	50 MPH Dir: W	Veh Mnvr/Ped Actn:				4	Obj Strk:		42			
Unit	2 : 2	Alchl/Drgs:	0	Speed:	50 MPH Dir: W	Veh Mnvr/Ped Actn:				11	Obj Strk:					
37	102929299	19.510	07/22/2010 20:06	RAN OFF ROAD - LEFT	\$ 22000	0	0	2	0	1	2	1	5	0	0	
Unit	1 : 1	Alchl/Drgs:	5	Speed:	100 MPH Dir: NE	Veh Mnvr/Ped Actn:				16	Obj Strk:		42			
38	102963837	19.510	09/11/2010 11:47	MOVABLE OBJECT	\$ 3000	0	0	0	0	2	1	3	3	0	0	1
Unit	1 : 1	Alchl/Drgs:	0	Speed:	60 MPH Dir: W	Veh Mnvr/Ped Actn:				4	Obj Strk:		42			
39	103193167	19.510	06/11/2011 17:43	SIDESWIPE, SAME DIRECTION	\$ 4000	0	0	0	0	1	1	1	1	0	0	
Unit	1 : 4	Alchl/Drgs:	0	Speed:	60 MPH Dir: W	Veh Mnvr/Ped Actn:				5	Obj Strk:					
Unit	2 : 1	Alchl/Drgs:	0	Speed:	60 MPH Dir: W	Veh Mnvr/Ped Actn:				4	Obj Strk:					

**North Carolina Department of Transportation
Traffic Engineering Accident Analysis System
Strip Analysis Report**

Acc No	Crash ID	Milepost	Date	Accident Type	Total Damage	Injuries				Condition			Road		Trfc Ctl	
						F	A	B	C	R	L	W	Ch	Ci	Dv	Op
40	103434652	19.510	04/12/2012 21:38	SIDESWIPE, SAME DIRECTION	\$ 10000	0	0	0	0	1	4	1	3	0		
Unit	1 : 1	Alchl/Drugs:	0	Speed: 70 MPH Dir: W		Veh Mnvr/Ped Actn:				5	Obj Strk:		44			
Unit	2 : 1	Alchl/Drugs:	0	Speed: 60 MPH Dir: W		Veh Mnvr/Ped Actn:				4	Obj Strk:					
41	103509868	19.600	07/21/2012 06:39	RAN OFF ROAD - LEFT	\$ 18000	0	0	0	1	1	1	1	7	0	0	2
Unit	1 : 1	Alchl/Drugs:	0	Speed: 60 MPH Dir: W		Veh Mnvr/Ped Actn:				4	Obj Strk:		42			
42	102686217	19.620	09/21/2009 18:34	RAN OFF ROAD - LEFT	\$ 2500	0	0	0	0	2	1	3	5	0		1
Unit	1 : 1	Alchl/Drugs:	0	Speed: 45 MPH Dir: N		Veh Mnvr/Ped Actn:				4	Obj Strk:		44			
43	103114693	19.650	03/09/2011 14:02	REAR END, SLOW OR STOP	\$ 2000	0	0	0	0	2	1	3	1	0	0	
Unit	1 : 14	Alchl/Drugs:	0	Speed: 50 MPH Dir: S		Veh Mnvr/Ped Actn:				11	Obj Strk:					
Unit	2 : 1	Alchl/Drugs:	0	Speed: 45 MPH Dir: S		Veh Mnvr/Ped Actn:				11	Obj Strk:					
44	103233826	19.650	08/16/2011 17:45	OTHER NON-COLLISION	\$ 3000	0	0	0	0	1	1	1	1	0		1
Unit	1 : 1	Alchl/Drugs:	0	Speed: 55 MPH Dir: E		Veh Mnvr/Ped Actn:				16	Obj Strk:					
45	103254981	19.650	09/06/2011 15:49	ANGLE	\$ 2000	0	0	0	0	1	1	2	1	0		2
Unit	1 : 2	Alchl/Drugs:	0	Speed: 50 MPH Dir: E		Veh Mnvr/Ped Actn:				5	Obj Strk:					
Unit	2 : 2	Alchl/Drugs:	0	Speed: 50 MPH Dir: E		Veh Mnvr/Ped Actn:				5	Obj Strk:					
46	102984230	19.810	09/27/2010 23:50	RAN OFF ROAD - RIGHT	\$ 1000	0	0	0	0	2	5	3	1	0	0	2
Unit	1 : 1	Alchl/Drugs:	7	Speed: 50 MPH Dir: W		Veh Mnvr/Ped Actn:				4	Obj Strk:					
47	102959180	19.950	08/31/2010 22:49	FIXED OBJECT	\$ 3000	0	0	0	0	1	4	1	5	2		
Unit	1 : 1	Alchl/Drugs:	0	Speed: 50 MPH Dir: E		Veh Mnvr/Ped Actn:				4	Obj Strk:		18			
48	103153037	19.950	04/26/2011 15:22	RAN OFF ROAD - RIGHT	\$ 1000	0	0	0	1	1	1	1	1	0		
Unit	1 : 4	Alchl/Drugs:	0	Speed: 60 MPH Dir: W		Veh Mnvr/Ped Actn:				4	Obj Strk:		61			
49	103396041	19.950	02/19/2012 00:03	RAN OFF ROAD - LEFT	\$ 1000	0	0	0	0	2	4	3	1	0	0	2
Unit	1 : 1	Alchl/Drugs:	0	Speed: 55 MPH Dir: E		Veh Mnvr/Ped Actn:				4	Obj Strk:		42			
50	103396064	19.950	02/19/2012 13:10	REAR END, SLOW OR STOP	\$ 9000	0	0	0	0	2	1	3	1	0		
Unit	1 : 5	Alchl/Drugs:	0	Speed: 10 MPH Dir: E		Veh Mnvr/Ped Actn:				11	Obj Strk:					
Unit	2 : 2	Alchl/Drugs:	0	Speed: 10 MPH Dir: E		Veh Mnvr/Ped Actn:				11	Obj Strk:					

**North Carolina Department of Transportation
Traffic Engineering Accident Analysis System
Strip Analysis Report**

Acc No	Crash ID	Milepost	Date	Accident Type	Total Damage	Injuries				Condition			Road		Trfc Ctl	
						F	A	B	C	R	L	W	Ch	Ci	Dv	Op
51	103396062	19.950	02/19/2012 14:03	REAR END, SLOW OR STOP	\$ 13000	0	0	0	1	2	1	3	1	0	0	
Unit	1 : 1	Alchl/Drgs:	0	Speed:	50 MPH Dir: E	Veh Mnvr/Ped Actn:				11	Obj Strk:					
Unit	2 : 2	Alchl/Drgs:	0	Speed:	50 MPH Dir: E	Veh Mnvr/Ped Actn:				11	Obj Strk:					
Unit	3 : 1	Alchl/Drgs:	0	Speed:	403 MPH Dir: E	Veh Mnvr/Ped Actn:				11	Obj Strk:					
52	103412884	19.950	03/13/2012 07:45	REAR END, SLOW OR STOP	\$ 5900	0	0	0	1	2	1	5	1	0	2	
Unit	1 : 10	Alchl/Drgs:	0	Speed:	50 MPH Dir: E	Veh Mnvr/Ped Actn:				4	Obj Strk:					
Unit	2 : 1	Alchl/Drgs:	0	Speed:	55 MPH Dir: E	Veh Mnvr/Ped Actn:				11	Obj Strk:		42			
53	103455000	19.950	05/05/2012 09:47	RAN OFF ROAD - RIGHT	\$ 2500	0	0	1	0	2	1	3	1	1	0	2
Unit	1 : 1	Alchl/Drgs:	0	Speed:	0 MPH Dir: E	Veh Mnvr/Ped Actn:				4	Obj Strk:		42			
54	102924612	20.010	07/18/2010 16:23	REAR END, SLOW OR STOP	\$ 1600	0	0	0	0	2	1	2	1	0	2	
Unit	1 : 4	Alchl/Drgs:	0	Speed:	45 MPH Dir: W	Veh Mnvr/Ped Actn:				4	Obj Strk:					
Unit	2 : 1	Alchl/Drgs:	0	Speed:	45 MPH Dir: W	Veh Mnvr/Ped Actn:				11	Obj Strk:					
55	102956037	20.010	08/25/2010 14:12	SIDESWIPE, SAME DIRECTION	\$ 9000	0	0	0	0	1	1	1	1	0		
Unit	1 : 25	Alchl/Drgs:	0	Speed:	0 MPH Dir: W	Veh Mnvr/Ped Actn:				4	Obj Strk:					
Unit	2 : 10	Alchl/Drgs:	0	Speed:	60 MPH Dir: W	Veh Mnvr/Ped Actn:				4	Obj Strk:					
56	103228625	20.010	08/06/2011 08:53	MOVABLE OBJECT	\$ 600	0	0	1	0	1	1	1	1	4	10	1
Unit	1 : 20	Alchl/Drgs:	0	Speed:	45 MPH Dir: W	Veh Mnvr/Ped Actn:				4	Obj Strk:		18			
57	102992638	20.100	10/15/2010 20:40	REAR END, SLOW OR STOP	\$ 1000	0	0	0	0	1	4	1	1	0	2	
Unit	1 : 1	Alchl/Drgs:	0	Speed:	15 MPH Dir: E	Veh Mnvr/Ped Actn:				4	Obj Strk:					
Unit	2 : 5	Alchl/Drgs:	0	Speed:	5 MPH Dir: E	Veh Mnvr/Ped Actn:				11	Obj Strk:					
58	102984238	20.120	09/28/2010 23:20	RAN OFF ROAD - RIGHT	\$ 2000	0	0	0	0	1	5	2	1	0	0	
Unit	1 : 1	Alchl/Drgs:	0	Speed:	60 MPH Dir: W	Veh Mnvr/Ped Actn:				4	Obj Strk:		38			
59	103245113	20.200	08/25/2011 08:00	REAR END, SLOW OR STOP	\$ 3000	0	0	0	1	1	1	1	1	0	0	
Unit	1 : 1	Alchl/Drgs:	0	Speed:	60 MPH Dir: S	Veh Mnvr/Ped Actn:				11	Obj Strk:					
Unit	2 : 1	Alchl/Drgs:	0	Speed:	65 MPH Dir: S	Veh Mnvr/Ped Actn:				4	Obj Strk:					
60	102684228	20.210	09/14/2009 14:28	SIDESWIPE, SAME DIRECTION	\$ 14000	0	0	0	1	1	1	1	3	0	0	2
Unit	1 : 14	Alchl/Drgs:	0	Speed:	60 MPH Dir: W	Veh Mnvr/Ped Actn:				4	Obj Strk:					
Unit	2 : 1	Alchl/Drgs:	0	Speed:	65 MPH Dir: W	Veh Mnvr/Ped Actn:				5	Obj Strk:		44			

**North Carolina Department of Transportation
Traffic Engineering Accident Analysis System
Strip Analysis Report**

Acc No	Crash ID	Milepost	Date	Accident Type	Total Damage	Injuries				Condition			Road		Trfc Ctl	
						F	A	B	C	R	L	W	Ch	Ci	Dv	Op
61	102822984	20.210	03/13/2010 16:07	MOVABLE OBJECT	\$ 600	0	0	0	0	1	1	3	5	0	0	
Unit	1 : 2	Alchl/Drgs:	0	Speed:	55 MPH Dir: E	Veh Mnvr/Ped Actn:				4	Obj Strk:					
Unit	2 : 5	Alchl/Drgs:	0	Speed:	55 MPH Dir: E	Veh Mnvr/Ped Actn:				4	Obj Strk:					
Unit	3 : 1	Alchl/Drgs:	7	Speed:	55 MPH Dir: E	Veh Mnvr/Ped Actn:				4	Obj Strk:					
62	102855182	20.250	04/13/2010 16:21	RAN OFF ROAD - RIGHT	\$ 10000	0	0	0	0	1	1	1	1	0	1	
Unit	1 : 1	Alchl/Drgs:	0	Speed:	50 MPH Dir: S	Veh Mnvr/Ped Actn:				4	Obj Strk:		59			
63	102950229	20.260	07/28/2010 13:43	REAR END, SLOW OR STOP	\$ 3500	0	0	0	0	1	1	1	7	0	2	1
Unit	1 : 1	Alchl/Drgs:	0	Speed:	35 MPH Dir: W	Veh Mnvr/Ped Actn:				4	Obj Strk:					
Unit	2 : 2	Alchl/Drgs:	0	Speed:	0 MPH Dir: W	Veh Mnvr/Ped Actn:				2	Obj Strk:					
64	103230678	20.260	07/23/2011 11:00	SIDESWIPE, SAME DIRECTION	\$ 1250	0	0	0	0	1	1	1	1	0	0	
Unit	1 : 12	Alchl/Drgs:	0	Speed:	60 MPH Dir: N	Veh Mnvr/Ped Actn:				5	Obj Strk:					
Unit	2 : 1	Alchl/Drgs:	0	Speed:	60 MPH Dir: N	Veh Mnvr/Ped Actn:				4	Obj Strk:					
65	103345638	20.300	12/14/2011 23:48	ANIMAL	\$ 1500	0	0	1	0	1	4	2	3	0		
Unit	1 : 1	Alchl/Drgs:	0	Speed:	55 MPH Dir: E	Veh Mnvr/Ped Actn:				4	Obj Strk:		17			
66	102796195	20.310	01/29/2010 17:30	SIDESWIPE, SAME DIRECTION	\$ 3400	0	0	0	0	5	4	4	1	1		
Unit	1 : 14	Alchl/Drgs:	0	Speed:	30 MPH Dir: E	Veh Mnvr/Ped Actn:				5	Obj Strk:					
Unit	2 : 14	Alchl/Drgs:	0	Speed:	30 MPH Dir: N	Veh Mnvr/Ped Actn:				11	Obj Strk:					
67	102835071	20.310	03/23/2010 15:29	REAR END, SLOW OR STOP	\$ 5000	0	0	0	0	1	1	1	1	0	1	
Unit	1 : 10	Alchl/Drgs:	0	Speed:	40 MPH Dir: W	Veh Mnvr/Ped Actn:				11	Obj Strk:					
Unit	2 : 5	Alchl/Drgs:	0	Speed:	20 MPH Dir: W	Veh Mnvr/Ped Actn:				11	Obj Strk:					
Unit	3 : 10	Alchl/Drgs:	0	Speed:	10 MPH Dir: W	Veh Mnvr/Ped Actn:				3	Obj Strk:					
68	102850411	20.310	04/11/2010 15:14	REAR END, SLOW OR STOP	\$ 9500	0	0	0	3	1	1	1	3	0		
Unit	1 : 1	Alchl/Drgs:	0	Speed:	55 MPH Dir: W	Veh Mnvr/Ped Actn:				11	Obj Strk:					
Unit	2 : 1	Alchl/Drgs:	0	Speed:	0 MPH Dir: W	Veh Mnvr/Ped Actn:				1	Obj Strk:					
Unit	3 : 1	Alchl/Drgs:	0	Speed:	0 MPH Dir: W	Veh Mnvr/Ped Actn:				1	Obj Strk:					
69	103213665	20.310	07/04/2011 17:51	RAN OFF ROAD - LEFT	\$ 1500	0	0	0	0	1	1	1	1	0	2	
Unit	1 : 1	Alchl/Drgs:	0	Speed:	60 MPH Dir: W	Veh Mnvr/Ped Actn:				4	Obj Strk:		44			

**North Carolina Department of Transportation
Traffic Engineering Accident Analysis System
Strip Analysis Report**

Acc No	Crash ID	Milepost	Date	Accident Type	Total Damage	Injuries				Condition			Road		Trfc Ctl	
						F	A	B	C	R	L	W	Ch	Ci	Dv	Op
70	103418254	20.310	03/23/2012 11:32	RAN OFF ROAD - RIGHT	\$ 1200	0	0	0	0	2	1	3	1	0	0	2
Unit	1 : 1	Alchl/Drgs:	0	Speed: 60 MPH Dir: W		Veh Mnvr/Ped Actn:				4	Obj Strk:		42			
71	103403644	20.320	03/16/2012 15:35	REAR END, SLOW OR STOP	\$ 5700	0	0	0	0	2	1	2	1	0	0	
Unit	1 : 4	Alchl/Drgs:	0	Speed: 50 MPH Dir: S		Veh Mnvr/Ped Actn:				5	Obj Strk:					
Unit	2 : 3	Alchl/Drgs:	0	Speed: 50 MPH Dir: S		Veh Mnvr/Ped Actn:				16	Obj Strk:					
72	103316375	20.340	11/03/2011 08:27	SIDESWIPE, SAME DIRECTION	\$ 500	0	0	0	1	1	1	1	1	0		1
Unit	1 : 2	Alchl/Drgs:	0	Speed: 65 MPH Dir: E		Veh Mnvr/Ped Actn:				5	Obj Strk:					
Unit	2 : 1	Alchl/Drgs:	0	Speed: 62 MPH Dir: E		Veh Mnvr/Ped Actn:				4	Obj Strk:					
73	102900239	20.410	06/28/2010 23:30	SIDESWIPE, SAME DIRECTION	\$ 1300	0	0	0	0	2	5	3	3	0	1	1
Unit	1 : 2	Alchl/Drgs:	0	Speed: 50 MPH Dir: W		Veh Mnvr/Ped Actn:				4	Obj Strk:					
Unit	2 : 4	Alchl/Drgs:	0	Speed: 25 MPH Dir: W		Veh Mnvr/Ped Actn:				5	Obj Strk:					
74	103223969	20.410	07/30/2011 09:36	SIDESWIPE, SAME DIRECTION	\$ 1300	0	0	0	0	1	1	1	1	0		2
Unit	1 : 14	Alchl/Drgs:	0	Speed: 55 MPH Dir: W		Veh Mnvr/Ped Actn:				16	Obj Strk:					
Unit	2 : 1	Alchl/Drgs:	0	Speed: 60 MPH Dir: W		Veh Mnvr/Ped Actn:				4	Obj Strk:					
75	103378055	20.410	01/20/2012 18:25	REAR END, SLOW OR STOP	\$ 2000	0	0	0	0	1	4	2	1	0		2
Unit	1 : 1	Alchl/Drgs:	0	Speed: 15 MPH Dir: W		Veh Mnvr/Ped Actn:				4	Obj Strk:					
Unit	2 : 1	Alchl/Drgs:	0	Speed: 10 MPH Dir: W		Veh Mnvr/Ped Actn:				11	Obj Strk:					
76	103472140	20.410	05/29/2012 01:48	RAN OFF ROAD - LEFT	\$ 150000	0	0	0	0	2	4	2	5	0	0	2
Unit	1 : 11	Alchl/Drgs:	0	Speed: 55 MPH Dir: W		Veh Mnvr/Ped Actn:				4	Obj Strk:		44			
77	103503359	20.410	07/03/2012 14:11	RAN OFF ROAD - LEFT	\$ 1300	0	0	0	0	1	1	2	3	0		
Unit	1 : 1	Alchl/Drgs:	0	Speed: 60 MPH Dir: W		Veh Mnvr/Ped Actn:				4	Obj Strk:		44			
78	103179347	20.420	05/29/2011 10:42	FIXED OBJECT	\$ 7000	0	0	0	0	1	1	1	1	0		
Unit	1 : 14	Alchl/Drgs:	0	Speed: 65 MPH Dir: NW		Veh Mnvr/Ped Actn:				4	Obj Strk:		44			
79	103369147	20.420	01/14/2012 11:49	REAR END, SLOW OR STOP	\$ 4000	0	0	0	0	1	1	1	1	0		2
Unit	1 : 1	Alchl/Drgs:	0	Speed: 0 MPH Dir: W		Veh Mnvr/Ped Actn:				1	Obj Strk:					
Unit	2 : 4	Alchl/Drgs:	0	Speed: 0 MPH Dir: W		Veh Mnvr/Ped Actn:				1	Obj Strk:					
Unit	3 : 1	Alchl/Drgs:	0	Speed: 35 MPH Dir: W		Veh Mnvr/Ped Actn:				4	Obj Strk:					

**North Carolina Department of Transportation
Traffic Engineering Accident Analysis System
Strip Analysis Report**

Acc No	Crash ID	Milepost	Date	Accident Type	Total Damage	Injuries				Condition			Road		Trfc Ctl	
						F	A	B	C	R	L	W	Ch	Ci	Dv	Op
80	103219755	20.425	07/23/2011 11:30	FIXED OBJECT	\$ 7000	0	0	0	0	1	1	1	3	0	0	2
Unit	1 : 1	Alchl/Drgs:	0	Speed:	45 MPH	Dir:	W	Veh Mnvr/Ped Actn:				11	Obj Strk:		44	
Unit	2 : 4	Alchl/Drgs:	0	Speed:	0 MPH	Dir:	W	Veh Mnvr/Ped Actn:				1	Obj Strk:			
81	102843045	20.450	04/08/2010 16:48	RAN OFF ROAD - RIGHT	\$ 3500	0	0	0	0	2	1	2	1	0	0	1
Unit	1 : 1	Alchl/Drgs:	0	Speed:	50 MPH	Dir:	S	Veh Mnvr/Ped Actn:				4	Obj Strk:		59	
82	103058761	20.450	12/12/2010 03:24	RAN OFF ROAD - LEFT	\$ 3000	0	0	0	0	4	5	6	3	1		
Unit	1 : 4	Alchl/Drgs:	0	Speed:	30 MPH	Dir:	E	Veh Mnvr/Ped Actn:				4	Obj Strk:		44	
83	103219754	20.482	07/23/2011 12:35	REAR END, SLOW OR STOP	\$ 6200	0	0	1	3	1	1	1	1	0		3
Unit	1 : 1	Alchl/Drgs:	0	Speed:	70 MPH	Dir:	W	Veh Mnvr/Ped Actn:				4	Obj Strk:			
Unit	2 : 4	Alchl/Drgs:	0	Speed:	0 MPH	Dir:	W	Veh Mnvr/Ped Actn:				1	Obj Strk:			
Unit	3 : 5	Alchl/Drgs:	0	Speed:	0 MPH	Dir:	W	Veh Mnvr/Ped Actn:				1	Obj Strk:			
Unit	4 : 5	Alchl/Drgs:	0	Speed:	0 MPH	Dir:	W	Veh Mnvr/Ped Actn:				1	Obj Strk:			
Unit	5 : 5	Alchl/Drgs:	0	Speed:	0 MPH	Dir:	W	Veh Mnvr/Ped Actn:				1	Obj Strk:			
84	102799999	20.491	01/30/2010 09:33	BACKING UP	\$ 11000	0	0	0	0	5	1	4	3	0	0	1
Unit	1 : 1	Alchl/Drgs:	0	Speed:	10 MPH	Dir:	S	Veh Mnvr/Ped Actn:				10	Obj Strk:			
Unit	2 : 1	Alchl/Drgs:	0	Speed:	40 MPH	Dir:	N	Veh Mnvr/Ped Actn:				4	Obj Strk:			
85	103021891	20.491	10/30/2010 18:28	REAR END, SLOW OR STOP	\$ 2000	0	0	0	0	1	1	1	5	0	0	
Unit	1 : 2	Alchl/Drgs:	0	Speed:	40 MPH	Dir:	W	Veh Mnvr/Ped Actn:				5	Obj Strk:			
Unit	2 : 4	Alchl/Drgs:	0	Speed:	40 MPH	Dir:	W	Veh Mnvr/Ped Actn:				5	Obj Strk:			
86	103164481	20.491	05/13/2011 16:34	REAR END, SLOW OR STOP	\$ 5000	0	0	0	0	1	1	1	1	0	0	2
Unit	1 : 4	Alchl/Drgs:	0	Speed:	15 MPH	Dir:	E	Veh Mnvr/Ped Actn:				4	Obj Strk:			
Unit	2 : 2	Alchl/Drgs:	0	Speed:	0 MPH	Dir:	E	Veh Mnvr/Ped Actn:				1	Obj Strk:			
87	103215134	20.491	07/16/2011 12:39	REAR END, SLOW OR STOP	\$ 7200	0	0	0	1	1	1	1	1	0	0	
Unit	1 : 5	Alchl/Drgs:	0	Speed:	50 MPH	Dir:	W	Veh Mnvr/Ped Actn:				4	Obj Strk:			
Unit	2 : 4	Alchl/Drgs:	0	Speed:	45 MPH	Dir:	W	Veh Mnvr/Ped Actn:				11	Obj Strk:			
Unit	3 : 4	Alchl/Drgs:	0	Speed:	40 MPH	Dir:	W	Veh Mnvr/Ped Actn:				11	Obj Strk:			
88	102683643	20.510	09/14/2009 15:46	REAR END, SLOW OR STOP	\$ 600	0	0	1	0	1	1	1	1	0	0	3
Unit	1 : 20	Alchl/Drgs:	0	Speed:	45 MPH	Dir:	W	Veh Mnvr/Ped Actn:				4	Obj Strk:			
Unit	2 : 1	Alchl/Drgs:	0	Speed:	0 MPH	Dir:	W	Veh Mnvr/Ped Actn:				1	Obj Strk:			

**North Carolina Department of Transportation
Traffic Engineering Accident Analysis System
Strip Analysis Report**

Acc No	Crash ID	Milepost	Date	Accident Type	Total Damage	Injuries				Condition			Road		Trfc Ctl		
						F	A	B	C	R	L	W	Ch	Ci	Dv	Op	
89	102855859	20.510	04/14/2010 10:31	REAR END, SLOW OR STOP	\$ 10000	0	0	0	0	1	1	1	1	1	0		
Unit	1 : 2	Alchl/Drgs:	0	Speed:	60 MPH	Dir:	E	Veh Mnvr/Ped Actn:				4	Obj Strk:				
Unit	2 : 1	Alchl/Drgs:	0	Speed:	40 MPH	Dir:	E	Veh Mnvr/Ped Actn:				11	Obj Strk:				
Unit	3 : 1	Alchl/Drgs:	0	Speed:	30 MPH	Dir:	E	Veh Mnvr/Ped Actn:				11	Obj Strk:				

90	103114696	20.510	03/09/2011 14:38	RAN OFF ROAD - LEFT	\$ 2500	0	0	0	0	2	1	3	5	0			
Unit	1 : 1	Alchl/Drgs:	0	Speed:	45 MPH	Dir:	N	Veh Mnvr/Ped Actn:				4	Obj Strk: 37				

91	103162668	20.510	05/14/2011 21:30	SIDESWIPE, SAME DIRECTION	\$ 4000	0	0	0	0	1	4	2	1	0			2
Unit	1 : 1	Alchl/Drgs:	1	Speed:	55 MPH	Dir:	E	Veh Mnvr/Ped Actn:				5	Obj Strk:				
Unit	2 : 1	Alchl/Drgs:	0	Speed:	55 MPH	Dir:	E	Veh Mnvr/Ped Actn:				4	Obj Strk:				

92	103179036	20.510	05/27/2011 17:11	REAR END, SLOW OR STOP	\$ 1500	0	0	0	1	1	1	1	1	0			2
Unit	1 : 4	Alchl/Drgs:	0	Speed:	45 MPH	Dir:	E	Veh Mnvr/Ped Actn:				5	Obj Strk:				
Unit	2 : 4	Alchl/Drgs:	0	Speed:	0 MPH	Dir:	E	Veh Mnvr/Ped Actn:				1	Obj Strk:				

93	103219752	20.510	07/21/2011 13:34	SIDESWIPE, SAME DIRECTION	\$ 1000	0	0	0	0	1	1	1	1	0			0
Unit	1 : 1	Alchl/Drgs:	0	Speed:	5 MPH	Dir:	E	Veh Mnvr/Ped Actn:				5	Obj Strk:				
Unit	2 : 5	Alchl/Drgs:	0	Speed:	15 MPH	Dir:	E	Veh Mnvr/Ped Actn:				4	Obj Strk:				

94	103229336	20.510	08/06/2011 13:42	REAR END, SLOW OR STOP	\$ 4000	0	0	0	0	1	1	2	1	0			
Unit	1 : 4	Alchl/Drgs:	0	Speed:	60 MPH	Dir:	W	Veh Mnvr/Ped Actn:				4	Obj Strk:				
Unit	2 : 1	Alchl/Drgs:	0	Speed:	0 MPH	Dir:	W	Veh Mnvr/Ped Actn:				1	Obj Strk:				
Unit	3 : 4	Alchl/Drgs:	0	Speed:	0 MPH	Dir:	W	Veh Mnvr/Ped Actn:				1	Obj Strk:				

95	103369153	20.510	01/14/2012 11:36	REAR END, SLOW OR STOP	\$ 10000	0	0	0	0	1	1	1	3	0			1
Unit	1 : 14	Alchl/Drgs:	0	Speed:	65 MPH	Dir:	N	Veh Mnvr/Ped Actn:				4	Obj Strk:				
Unit	2 : 1	Alchl/Drgs:	0	Speed:	0 MPH	Dir:	N	Veh Mnvr/Ped Actn:				1	Obj Strk:				

96	103511035	20.510	07/13/2012 12:53	ANGLE	\$ 5020	0	0	0	0	2	1	2	1	0			2
Unit	1 : 1	Alchl/Drgs:	0	Speed:	65 MPH	Dir:	N	Veh Mnvr/Ped Actn:				11	Obj Strk:				
Unit	2 : 5	Alchl/Drgs:	0	Speed:	60 MPH	Dir:	N	Veh Mnvr/Ped Actn:				4	Obj Strk:				
Unit	3 : 4	Alchl/Drgs:	0	Speed:	60 MPH	Dir:	N	Veh Mnvr/Ped Actn:				4	Obj Strk:				

97	103506986	20.510	07/13/2012 13:48	ANGLE	\$ 2600	0	0	0	0	1	1	2	1	0			
Unit	1 : 2	Alchl/Drgs:	0	Speed:	45 MPH	Dir:	W	Veh Mnvr/Ped Actn:				11	Obj Strk:				
Unit	2 : 5	Alchl/Drgs:	0	Speed:	45 MPH	Dir:	W	Veh Mnvr/Ped Actn:				1	Obj Strk:				

**North Carolina Department of Transportation
Traffic Engineering Accident Analysis System
Strip Analysis Report**

Acc No	Crash ID	Milepost	Date	Accident Type	Total Damage	Injuries				Condition			Road		Trfc Ctl	
						F	A	B	C	R	L	W	Ch	Ci	Dv	Op
98	103519490	20.510	07/31/2012 14:53	SIDESWIPE, SAME DIRECTION	\$ 500	0	0	0	0	1	1	1	5	0	0	2
Unit	1 : 32	Alchl/Drgs:	7	Speed: 65 MPH Dir: E		Veh Mnvr/Ped Actn:				6	Obj Strk:					
Unit	2 : 1	Alchl/Drgs:	0	Speed: 60 MPH Dir: E		Veh Mnvr/Ped Actn:				4	Obj Strk:					
99	102840444	20.520	04/12/2010 20:24	REAR END, SLOW OR STOP	\$ 12000	0	0	1	0	1	5	1	1	0	0	
Unit	1 : 5	Alchl/Drgs:	0	Speed: 35 MPH Dir: W		Veh Mnvr/Ped Actn:				4	Obj Strk:					
Unit	2 : 1	Alchl/Drgs:	0	Speed: 0 MPH Dir: W		Veh Mnvr/Ped Actn:				1	Obj Strk:					
Unit	3 : 4	Alchl/Drgs:	0	Speed: 0 MPH Dir: W		Veh Mnvr/Ped Actn:				1	Obj Strk:					
100	102962178	20.520	09/11/2010 11:55	SIDESWIPE, SAME DIRECTION	\$ 21400	0	0	0	1	2	1	2	1	0	0	
Unit	1 : 1	Alchl/Drgs:	7	Speed: 50 MPH Dir: N		Veh Mnvr/Ped Actn:				4	Obj Strk:					
Unit	2 : 1	Alchl/Drgs:	0	Speed: 50 MPH Dir: N		Veh Mnvr/Ped Actn:				4	Obj Strk:					
Unit	3 : 2	Alchl/Drgs:	0	Speed: 50 MPH Dir: N		Veh Mnvr/Ped Actn:				1	Obj Strk:					
Unit	4 : 2	Alchl/Drgs:	0	Speed: 50 MPH Dir: N		Veh Mnvr/Ped Actn:				1	Obj Strk:					
101	103145474	20.521	04/06/2011 07:48	REAR END, SLOW OR STOP	\$ 6100	0	0	0	1	1	1	1	1	0		
Unit	1 : 1	Alchl/Drgs:	0	Speed: 40 MPH Dir: S		Veh Mnvr/Ped Actn:				4	Obj Strk:					
Unit	2 : 1	Alchl/Drgs:	0	Speed: 40 MPH Dir: S		Veh Mnvr/Ped Actn:				11	Obj Strk:					
Unit	3 : 1	Alchl/Drgs:	0	Speed: 30 MPH Dir: S		Veh Mnvr/Ped Actn:				11	Obj Strk:					
Unit	4 : 1	Alchl/Drgs:	0	Speed: 30 MPH Dir: S		Veh Mnvr/Ped Actn:				11	Obj Strk:					
Unit	5 : 1	Alchl/Drgs:	0	Speed: 30 MPH Dir: S		Veh Mnvr/Ped Actn:				11	Obj Strk:					
Unit	6 : 1	Alchl/Drgs:	0	Speed: 30 MPH Dir: S		Veh Mnvr/Ped Actn:				11	Obj Strk:					
Unit	7 : 1	Alchl/Drgs:	0	Speed: 40 MPH Dir: S		Veh Mnvr/Ped Actn:				11	Obj Strk:					
102	102850445	20.529	04/11/2010 14:30	REAR END, SLOW OR STOP	\$ 7000	0	0	0	1	1	1	1	1	0		
Unit	1 : 5	Alchl/Drgs:	0	Speed: 30 MPH Dir: E		Veh Mnvr/Ped Actn:				4	Obj Strk:					
Unit	2 : 1	Alchl/Drgs:	0	Speed: 25 MPH Dir: E		Veh Mnvr/Ped Actn:				4	Obj Strk:					
Unit	3 : 1	Alchl/Drgs:	0	Speed: 20 MPH Dir: E		Veh Mnvr/Ped Actn:				4	Obj Strk:					
103	102950781	20.529	08/23/2010 06:37	RAN OFF ROAD - RIGHT	\$ 3500	0	0	0	0	1	1	2	1	12	0	1
Unit	1 : 1	Alchl/Drgs:	0	Speed: 65 MPH Dir: S		Veh Mnvr/Ped Actn:				5	Obj Strk:		38			
104	102683901	20.548	09/13/2009 12:13	SIDESWIPE, SAME DIRECTION	\$ 3100	0	0	0	2	1	1	1	3	0		
Unit	1 : 1	Alchl/Drgs:	0	Speed: 40 MPH Dir: E		Veh Mnvr/Ped Actn:				5	Obj Strk:					
Unit	2 : 2	Alchl/Drgs:	0	Speed: 65 MPH Dir: E		Veh Mnvr/Ped Actn:				4	Obj Strk:					
105	102968573	20.548	09/15/2010 08:18	REAR END, SLOW OR STOP	\$ 1500	0	0	0	0	1	1	1	1	10		1
Unit	1 : 1	Alchl/Drgs:	0	Speed: 20 MPH Dir: S		Veh Mnvr/Ped Actn:				4	Obj Strk:					

**North Carolina Department of Transportation
Traffic Engineering Accident Analysis System
Strip Analysis Report**

Acc No	Crash ID	Milepost	Date	Accident Type	Total Damage	Injuries				Condition			Road		Trfc Ctl	
						F	A	B	C	R	L	W	Ch	Ci	Dv	Op
Unit	2 : 4	Alchl/Drgs:	0	Speed:	10 MPH Dir: S	Veh Mnvr/Ped Actn:				11	Obj Strk:					
106	103187239	20.548	06/06/2011 18:03	REAR END, SLOW OR STOP	\$ 2200	0	0	0	0	1	1	2	1	0		
Unit	1 : 1	Alchl/Drgs:	0	Speed:	20 MPH Dir: E	Veh Mnvr/Ped Actn:				4	Obj Strk:					
Unit	2 : 4	Alchl/Drgs:	0	Speed:	15 MPH Dir: E	Veh Mnvr/Ped Actn:				11	Obj Strk:					
107	102659772	20.567	08/11/2009 17:15	REAR END, SLOW OR STOP	\$ 2800	0	0	0	0	1	1	1	3	0	0	
Unit	1 : 1	Alchl/Drgs:	0	Speed:	60 MPH Dir: E	Veh Mnvr/Ped Actn:				4	Obj Strk:					
Unit	2 : 4	Alchl/Drgs:	0	Speed:	55 MPH Dir: E	Veh Mnvr/Ped Actn:				4	Obj Strk:					
108	102947016	20.586	08/13/2010 18:13	REAR END, SLOW OR STOP	\$ 5300	0	0	0	0	2	1	3	1	0	0	3
Unit	1 : 14	Alchl/Drgs:	0	Speed:	25 MPH Dir: E	Veh Mnvr/Ped Actn:				4	Obj Strk:					
Unit	2 : 1	Alchl/Drgs:	0	Speed:	25 MPH Dir: E	Veh Mnvr/Ped Actn:				4	Obj Strk:					
109	102850850	20.610	04/15/2010 09:55	REAR END, SLOW OR STOP	\$ 2250	0	0	0	0	1	1	1	3	0	0	
Unit	1 : 2	Alchl/Drgs:	0	Speed:	60 MPH Dir: NW	Veh Mnvr/Ped Actn:				4	Obj Strk:					
Unit	2 : 2	Alchl/Drgs:	0	Speed:	60 MPH Dir: NW	Veh Mnvr/Ped Actn:				11	Obj Strk:					
110	102859690	20.610	05/10/2010 17:31	REAR END, SLOW OR STOP	\$ 7750	0	0	0	0	2	1	2	2	0	0	
Unit	1 : 1	Alchl/Drgs:	7	Speed:	55 MPH Dir: E	Veh Mnvr/Ped Actn:				4	Obj Strk:					
Unit	2 : 1	Alchl/Drgs:	0	Speed:	55 MPH Dir: E	Veh Mnvr/Ped Actn:				11	Obj Strk:					
111	102903247	20.610	06/30/2010 21:36	REAR END, SLOW OR STOP	\$ 4000	0	0	0	0	1	5	1	3	0	0	
Unit	1 : 4	Alchl/Drgs:	0	Speed:	15 MPH Dir: S	Veh Mnvr/Ped Actn:				4	Obj Strk:					
Unit	2 : 1	Alchl/Drgs:	0	Speed:	5 MPH Dir: S	Veh Mnvr/Ped Actn:				11	Obj Strk:					
Unit	3 : 4	Alchl/Drgs:	0	Speed:	10 MPH Dir: S	Veh Mnvr/Ped Actn:				1	Obj Strk:					
112	103136443	20.610	04/05/2011 11:32	SIDESWIPE, SAME DIRECTION	\$ 1400	0	0	0	0	1	1	1	1	0	0	
Unit	1 : 1	Alchl/Drgs:	0	Speed:	60 MPH Dir: E	Veh Mnvr/Ped Actn:				5	Obj Strk:					
Unit	2 : 1	Alchl/Drgs:	0	Speed:	60 MPH Dir: E	Veh Mnvr/Ped Actn:				4	Obj Strk:					
113	103213642	20.610	07/02/2011 13:15	REAR END, SLOW OR STOP	\$ 4500	0	0	0	0	1	1	1	1	0		
Unit	1 : 2	Alchl/Drgs:	0	Speed:	60 MPH Dir: W	Veh Mnvr/Ped Actn:				11	Obj Strk:					
Unit	2 : 1	Alchl/Drgs:	0	Speed:	0 MPH Dir: W	Veh Mnvr/Ped Actn:				1	Obj Strk:					
114	103322297	20.610	11/14/2011 18:22	RAN OFF ROAD - LEFT	\$ 2000	0	0	0	0	1	4	1	1	0	0	2
Unit	1 : 32	Alchl/Drgs:	7	Speed:	0 MPH Dir: S	Veh Mnvr/Ped Actn:				5	Obj Strk: 42					
Unit	2 : 1	Alchl/Drgs:	0	Speed:	55 MPH Dir: N	Veh Mnvr/Ped Actn:				4	Obj Strk: 42					

**North Carolina Department of Transportation
Traffic Engineering Accident Analysis System
Strip Analysis Report**

Acc No	Crash ID	Milepost	Date	Accident Type	Total Damage	Injuries				Condition			Road		Trfc Ctl	
						F	A	B	C	R	L	W	Ch	Ci	Dv	Op
115	103403814	20.610	03/16/2012 15:35	REAR END, SLOW OR STOP	\$ 28000	0	1	1	0	2	1	3	1	0	0	
Unit	1 : 1	Alchl/Drugs:	0	Speed: 50 MPH Dir: S		Veh Mnvr/Ped Actn:				4	Obj Strk:		44			
Unit	2 : 2	Alchl/Drugs:	0	Speed: 50 MPH Dir: S		Veh Mnvr/Ped Actn:				1	Obj Strk:					
Unit	3 : 1	Alchl/Drugs:	0	Speed: 50 MPH Dir: S		Veh Mnvr/Ped Actn:				1	Obj Strk:					
Unit	4 : 2	Alchl/Drugs:	0	Speed: 50 MPH Dir: S		Veh Mnvr/Ped Actn:				16	Obj Strk:		42			
Unit	5 : 1	Alchl/Drugs:	0	Speed: 50 MPH Dir: S		Veh Mnvr/Ped Actn:				1	Obj Strk:					
116	103404264	20.610	03/16/2012 15:35	REAR END, SLOW OR STOP	\$ 1000	0	0	0	0	2	1	3	1	0	0	
Unit	1 : 32	Alchl/Drugs:	7	Speed: 0 MPH Dir: E		Veh Mnvr/Ped Actn:				4	Obj Strk:					
Unit	2 : 4	Alchl/Drugs:	0	Speed: 20 MPH Dir: E		Veh Mnvr/Ped Actn:				11	Obj Strk:					
117	103462749	20.610	05/22/2012 15:08	FIXED OBJECT	\$ 4500	0	0	0	1	1	1	2	1	0		
Unit	1 : 1	Alchl/Drugs:	0	Speed: 50 MPH Dir: E		Veh Mnvr/Ped Actn:				5	Obj Strk:		44			
118	103341576	20.620	12/09/2011 18:14	REAR END, SLOW OR STOP	\$ 6500	0	0	0	0	1	5	1	1	0		
Unit	1 : 1	Alchl/Drugs:	0	Speed: 50 MPH Dir: E		Veh Mnvr/Ped Actn:				11	Obj Strk:					
Unit	2 : 1	Alchl/Drugs:	0	Speed: 50 MPH Dir: E		Veh Mnvr/Ped Actn:				11	Obj Strk:					
119	103498053	20.700	07/12/2012 07:24	OTHER COLLISION WITH VEHICLE	\$ 8000	0	0	0	0	2	1	3	1	0	0	
Unit	1 : 1	Alchl/Drugs:	0	Speed: 60 MPH Dir: E		Veh Mnvr/Ped Actn:				5	Obj Strk:					
Unit	2 : 2	Alchl/Drugs:	0	Speed: 60 MPH Dir: E		Veh Mnvr/Ped Actn:				5	Obj Strk:		59			
120	102890670	20.710	06/17/2010 15:52	REAR END, SLOW OR STOP	\$ 6000	0	0	0	2	1	1	1	3	0	0	
Unit	1 : 9	Alchl/Drugs:	0	Speed: 50 MPH Dir: E		Veh Mnvr/Ped Actn:				4	Obj Strk:					
Unit	2 : 2	Alchl/Drugs:	0	Speed: 50 MPH Dir: E		Veh Mnvr/Ped Actn:				4	Obj Strk:					
121	103021876	20.710	10/17/2010 17:02	REAR END, SLOW OR STOP	\$ 1500	0	0	0	0	1	1	1	3	0	0	2
Unit	1 : 2	Alchl/Drugs:	7	Speed: 55 MPH Dir: E		Veh Mnvr/Ped Actn:				4	Obj Strk:					
Unit	2 : 5	Alchl/Drugs:	0	Speed: 35 MPH Dir: E		Veh Mnvr/Ped Actn:				4	Obj Strk:					
122	103020511	20.710	10/29/2010 20:02	SIDESWIPE, SAME DIRECTION	\$ 5500	0	0	0	0	1	4	1	1	0		2
Unit	1 : 1	Alchl/Drugs:	0	Speed: 60 MPH Dir: E		Veh Mnvr/Ped Actn:				15	Obj Strk:					
Unit	2 : 2	Alchl/Drugs:	0	Speed: 0 MPH Dir: E		Veh Mnvr/Ped Actn:				1	Obj Strk:					
Unit	3 : 2	Alchl/Drugs:	0	Speed: 0 MPH Dir: E		Veh Mnvr/Ped Actn:				1	Obj Strk:					
123	103020504	20.710	10/29/2010 20:29	REAR END, SLOW OR STOP	\$ 5000	0	0	0	0	1	4	1	1	0	0	2
Unit	1 : 1	Alchl/Drugs:	0	Speed: 30 MPH Dir: S		Veh Mnvr/Ped Actn:				4	Obj Strk:					

**North Carolina Department of Transportation
Traffic Engineering Accident Analysis System
Strip Analysis Report**

Acc No	Crash ID	Milepost	Date	Accident Type	Total Damage	Injuries				Condition			Road		Trfc Ctl	
						F	A	B	C	R	L	W	Ch	Ci	Dv	Op
Unit	2 : 1	Alchl/Drgs:	0	Speed:	40 MPH	Dir:	S	Veh Mnvr/Ped Actn:				4	Obj Strk:			
124	103223967	20.710	08/01/2011 18:08	OTHER COLLISION WITH VEHICLE	\$ 250	0	0	0	0	1	1	1	1	0	0	2
Unit	1 : 32	Alchl/Drgs:	7	Speed:	60 MPH	Dir:	N	Veh Mnvr/Ped Actn:				4	Obj Strk:			
Unit	2 : 4	Alchl/Drgs:	0	Speed:	55 MPH	Dir:	NW	Veh Mnvr/Ped Actn:				4	Obj Strk:			
125	103386029	20.710	02/03/2012 12:37	RAN OFF ROAD - RIGHT	\$ 1500	0	0	0	0	1	1	1	1	0	0	
Unit	1 : 2	Alchl/Drgs:	0	Speed:	55 MPH	Dir:	W	Veh Mnvr/Ped Actn:				4	Obj Strk: 18			
126	103399046	20.710	02/19/2012 12:50	REAR END, SLOW OR STOP	\$ 6100	0	0	0	0	2	1	3	2	0		
Unit	1 : 2	Alchl/Drgs:	0	Speed:	60 MPH	Dir:	E	Veh Mnvr/Ped Actn:				11	Obj Strk:			
Unit	2 : 1	Alchl/Drgs:	0	Speed:	0 MPH	Dir:	E	Veh Mnvr/Ped Actn:				1	Obj Strk:			
Unit	3 : 2	Alchl/Drgs:	0	Speed:	0 MPH	Dir:	E	Veh Mnvr/Ped Actn:				1	Obj Strk:			
127	103454816	20.710	04/25/2012 18:10	RAN OFF ROAD - RIGHT	\$ 7500	0	0	0	1	1	1	1	1	0	0	2
Unit	1 : 1	Alchl/Drgs:	0	Speed:	50 MPH	Dir:	E	Veh Mnvr/Ped Actn:				4	Obj Strk: 42			
128	102950228	20.730	08/13/2010 18:10	REAR END, SLOW OR STOP	\$ 2700	0	0	0	3	3	1	3	3	0	0	
Unit	1 : 1	Alchl/Drgs:	0	Speed:	25 MPH	Dir:	S	Veh Mnvr/Ped Actn:				4	Obj Strk:			
Unit	2 : 1	Alchl/Drgs:	0	Speed:	5 MPH	Dir:	S	Veh Mnvr/Ped Actn:				11	Obj Strk:			
Unit	3 : 1	Alchl/Drgs:	0	Speed:	0 MPH	Dir:	S	Veh Mnvr/Ped Actn:				11	Obj Strk:			
Unit	4 : 1	Alchl/Drgs:	0	Speed:	10 MPH	Dir:	S	Veh Mnvr/Ped Actn:				11	Obj Strk:			
129	103353453	20.730	01/14/2012 11:40	REAR END, SLOW OR STOP	\$ 4500	0	0	0	0	1	1	1	1	0	0	
Unit	1 : 1	Alchl/Drgs:	0	Speed:	60 MPH	Dir:	W	Veh Mnvr/Ped Actn:				4	Obj Strk:			
Unit	2 : 1	Alchl/Drgs:	0	Speed:	35 MPH	Dir:	W	Veh Mnvr/Ped Actn:				11	Obj Strk:			
130	102988223	20.760	10/08/2010 15:57	REAR END, SLOW OR STOP	\$ 5000	0	0	0	2	1	1	1	1	0	0	1
Unit	1 : 1	Alchl/Drgs:	0	Speed:	50 MPH	Dir:	S	Veh Mnvr/Ped Actn:				4	Obj Strk:			
Unit	2 : 1	Alchl/Drgs:	0	Speed:	20 MPH	Dir:	S	Veh Mnvr/Ped Actn:				11	Obj Strk:			
131	102988219	20.760	10/08/2010 15:58	REAR END, SLOW OR STOP	\$ 17000	0	0	1	1	1	1	1	1	0	0	1
Unit	1 : 1	Alchl/Drgs:	0	Speed:	65 MPH	Dir:	S	Veh Mnvr/Ped Actn:				4	Obj Strk:			
Unit	2 : 1	Alchl/Drgs:	0	Speed:	0 MPH	Dir:	S	Veh Mnvr/Ped Actn:				1	Obj Strk:			
132	103411796	20.790	03/16/2012 16:17	REAR END, SLOW OR STOP	\$ 3500	0	0	0	0	2	1	3	3	0		
Unit	1 : 1	Alchl/Drgs:	0	Speed:	55 MPH	Dir:	SE	Veh Mnvr/Ped Actn:				4	Obj Strk:			
Unit	2 : 1	Alchl/Drgs:	0	Speed:	25 MPH	Dir:	SE	Veh Mnvr/Ped Actn:				11	Obj Strk:			

**North Carolina Department of Transportation
Traffic Engineering Accident Analysis System
Strip Analysis Report**

Acc No	Crash ID	Milepost	Date	Accident Type	Total Damage	Injuries				Condition			Road		Trfc Ctl	
						F	A	B	C	R	L	W	Ch	Ci	Dv	Op
133	102780818	20.810	01/14/2010 14:00	SIDESWIPE, SAME DIRECTION	\$ 14000	0	0	0	0	1	1	1	1	0	0	
Unit	1 : 1	Alchl/Drugs:	0	Speed: 70 MPH Dir: E		Veh Mnvr/Ped Actn:				5	Obj Strk:					
Unit	2 : 2	Alchl/Drugs:	0	Speed: 60 MPH Dir: E		Veh Mnvr/Ped Actn:				4	Obj Strk:					
134	103279178	20.810	10/19/2011 10:09	FIXED OBJECT	\$ 3500	0	0	0	0	2	1	2	1	0	0	
Unit	1 : 1	Alchl/Drugs:	0	Speed: 60 MPH Dir: SE		Veh Mnvr/Ped Actn:				4	Obj Strk:		44			
135	103425899	20.810	04/13/2012 22:47	PEDESTRIAN	\$ 800	1	0	0	0	1	5	1	3	0	0	
Unit	1 : 1	Alchl/Drugs:	0	Speed: 55 MPH Dir: E		Veh Mnvr/Ped Actn:				4	Obj Strk:		14			
Unit	2 : 1	Alchl/Drugs:	0	Speed: 55 MPH Dir: E		Veh Mnvr/Ped Actn:				4	Obj Strk:		14			
Unit	3 : 24	Alchl/Drugs:	1	Speed: 0 MPH Dir:		Veh Mnvr/Ped Actn:					Obj Strk:		14			
136	102652100	20.890	08/11/2009 16:24	RAN OFF ROAD - LEFT	\$ 5000	0	0	0	0	2	1	3	2	0	0	
Unit	1 : 2	Alchl/Drugs:	0	Speed: 50 MPH Dir: W		Veh Mnvr/Ped Actn:				4	Obj Strk:		48			
Unit	2 : 14	Alchl/Drugs:	0	Speed: 45 MPH Dir: W		Veh Mnvr/Ped Actn:				4	Obj Strk:					
137	102986666	20.910	10/15/2010 19:17	REAR END, SLOW OR STOP	\$ 11200	0	0	0	1	1	2	1	3	0	0	
Unit	1 : 4	Alchl/Drugs:	0	Speed: 60 MPH Dir: E		Veh Mnvr/Ped Actn:				1	Obj Strk:					
Unit	2 : 1	Alchl/Drugs:	0	Speed: 60 MPH Dir: E		Veh Mnvr/Ped Actn:				1	Obj Strk:					
Unit	3 : 1	Alchl/Drugs:	0	Speed: 60 MPH Dir: E		Veh Mnvr/Ped Actn:				1	Obj Strk:					
Unit	4 : 1	Alchl/Drugs:	0	Speed: 60 MPH Dir: E		Veh Mnvr/Ped Actn:				1	Obj Strk:					
Unit	5 : 4	Alchl/Drugs:	0	Speed: 60 MPH Dir: E		Veh Mnvr/Ped Actn:				4	Obj Strk:					
138	102980990	20.920	10/09/2010 20:01	REAR END, SLOW OR STOP	\$ 7800	0	0	0	0	1	5	1	1	0	0	
Unit	1 : 1	Alchl/Drugs:	0	Speed: 55 MPH Dir: E		Veh Mnvr/Ped Actn:				4	Obj Strk:					
Unit	2 : 1	Alchl/Drugs:	0	Speed: 55 MPH Dir: E		Veh Mnvr/Ped Actn:				4	Obj Strk:					
Unit	3 : 4	Alchl/Drugs:	0	Speed: 55 MPH Dir: E		Veh Mnvr/Ped Actn:				4	Obj Strk:					
139	103191629	20.920	07/02/2011 11:24	FIXED OBJECT	\$ 11000	0	0	0	1	1	1	1	4	0	0	
Unit	1 : 4	Alchl/Drugs:	0	Speed: 60 MPH Dir: S		Veh Mnvr/Ped Actn:				4	Obj Strk:		44			
140	103285554	20.920	10/21/2011 14:58	ANIMAL	\$ 1500	0	0	0	0	1	1	1	1	0	0	
Unit	1 : 1	Alchl/Drugs:	0	Speed: 65 MPH Dir: E		Veh Mnvr/Ped Actn:				4	Obj Strk:		17			
141	103414309	20.946	03/16/2012 15:32	REAR END, SLOW OR STOP	\$ 6400	0	0	0	2	2	1	3	3	0	0	1
Unit	1 : 4	Alchl/Drugs:	0	Speed: 60 MPH Dir: E		Veh Mnvr/Ped Actn:				11	Obj Strk:					
Unit	2 : 1	Alchl/Drugs:	0	Speed: 60 MPH Dir: E		Veh Mnvr/Ped Actn:				11	Obj Strk:					

**North Carolina Department of Transportation
Traffic Engineering Accident Analysis System
Strip Analysis Report**

Acc No	Crash ID	Milepost	Date	Accident Type	Total Damage	Injuries				Condition			Road		Trfc Ctl	
						F	A	B	C	R	L	W	Ch	Ci	Dv	Op
Unit	3 : 1	Alchl/Drgs:	0	Speed:	60 MPH	Dir:	E	Veh Mnvr/Ped Actn:				11	Obj Strk:			
142	102654673	21.010	08/13/2009 21:30	REAR END, SLOW OR STOP	\$ 1500	0	0	0	0	1	5	1	1	0	0	
Unit	1 : 1	Alchl/Drgs:	1	Speed:	45 MPH	Dir:	S	Veh Mnvr/Ped Actn:				4	Obj Strk:			
Unit	2 : 1	Alchl/Drgs:	0	Speed:	0 MPH	Dir:	S	Veh Mnvr/Ped Actn:				1	Obj Strk:			
143	102767999	21.010	12/21/2009 17:15	REAR END, SLOW OR STOP	\$ 900	0	0	0	1	2	2	2	1	0		
Unit	1 : 4	Alchl/Drgs:	0	Speed:	45 MPH	Dir:	W	Veh Mnvr/Ped Actn:				4	Obj Strk:			
Unit	2 : 1	Alchl/Drgs:	0	Speed:	45 MPH	Dir:	W	Veh Mnvr/Ped Actn:				11	Obj Strk:			
144	103184369	21.010	05/30/2011 15:06	RAN OFF ROAD - RIGHT	\$ 2000	0	0	0	1	1	1	1	1	0	2	
Unit	1 : 1	Alchl/Drgs:	0	Speed:	40 MPH	Dir:	E	Veh Mnvr/Ped Actn:				5	Obj Strk: 42			
145	103297198	21.010	10/25/2011 16:26	FIXED OBJECT	\$ 1000	0	0	0	0	1	1	1	5	0		
Unit	1 : 1	Alchl/Drgs:	0	Speed:	50 MPH	Dir:	E	Veh Mnvr/Ped Actn:				5	Obj Strk:			
Unit	2 : 1	Alchl/Drgs:	0	Speed:	50 MPH	Dir:	E	Veh Mnvr/Ped Actn:				4	Obj Strk: 42			
146	103287966	21.010	10/30/2011 04:10	OTHER COLLISION WITH VEHICLE	\$ 12000	0	0	0	0	1	5	1	1	0	0	
Unit	1 : 4	Alchl/Drgs:	1	Speed:	70 MPH	Dir:	W	Veh Mnvr/Ped Actn:				4	Obj Strk:			
Unit	2 : 2	Alchl/Drgs:	0	Speed:	55 MPH	Dir:	W	Veh Mnvr/Ped Actn:				4	Obj Strk: 44			
147	103320344	21.010	11/10/2011 18:27	REAR END, SLOW OR STOP	\$ 3000	0	0	0	0	1	4	1	1	0	2	
Unit	1 : 2	Alchl/Drgs:	0	Speed:	60 MPH	Dir:	S	Veh Mnvr/Ped Actn:				4	Obj Strk:			
Unit	2 : 4	Alchl/Drgs:	0	Speed:	60 MPH	Dir:	S	Veh Mnvr/Ped Actn:				11	Obj Strk:			
148	103498045	21.010	07/12/2012 08:47	REAR END, SLOW OR STOP	\$ 6000	0	0	0	0	2	1	3	1	0	0	
Unit	1 : 1	Alchl/Drgs:	0	Speed:	45 MPH	Dir:	E	Veh Mnvr/Ped Actn:				4	Obj Strk:			
Unit	2 : 4	Alchl/Drgs:	0	Speed:	45 MPH	Dir:	E	Veh Mnvr/Ped Actn:				4	Obj Strk:			
149	103247241	21.020	09/09/2011 15:39	REAR END, SLOW OR STOP	\$ 2700	0	0	0	0	1	1	2	3	0	0	
Unit	1 : 1	Alchl/Drgs:	0	Speed:	45 MPH	Dir:	W	Veh Mnvr/Ped Actn:				4	Obj Strk:			
Unit	2 : 4	Alchl/Drgs:	0	Speed:	45 MPH	Dir:	W	Veh Mnvr/Ped Actn:				11	Obj Strk:			
Unit	3 : 2	Alchl/Drgs:	0	Speed:	45 MPH	Dir:	W	Veh Mnvr/Ped Actn:				1	Obj Strk:			
150	103299466	21.020	11/10/2011 18:07	REAR END, SLOW OR STOP	\$ 16700	0	0	0	2	1	5	1	1	0	0	
Unit	1 : 2	Alchl/Drgs:	0	Speed:	65 MPH	Dir:	SE	Veh Mnvr/Ped Actn:				11	Obj Strk:			
Unit	2 : 4	Alchl/Drgs:	0	Speed:	35 MPH	Dir:	SE	Veh Mnvr/Ped Actn:				11	Obj Strk:			
Unit	3 : 1	Alchl/Drgs:	0	Speed:	10 MPH	Dir:	SE	Veh Mnvr/Ped Actn:				11	Obj Strk:			

**North Carolina Department of Transportation
Traffic Engineering Accident Analysis System
Strip Analysis Report**

Acc No	Crash ID	Milepost	Date	Accident Type	Total Damage	Injuries				Condition			Road		Trfc Ctl	
						F	A	B	C	R	L	W	Ch	Ci	Dv	Op
Unit	4 : 1	Alchl/Drgs:	0	Speed:	10 MPH	Dir:	SE	Veh Mnvr/Ped Actn:				11	Obj Strk:			
151	103385106	21.020	02/23/2012 13:00	REAR END, SLOW OR STOP	\$ 5500	0	0	0	0	1	1	1	3	0	0	
Unit	1 : 4	Alchl/Drgs:	0	Speed:	35 MPH	Dir:	N	Veh Mnvr/Ped Actn:				11	Obj Strk:			
Unit	2 : 4	Alchl/Drgs:	0	Speed:	35 MPH	Dir:	N	Veh Mnvr/Ped Actn:				1	Obj Strk:			
Unit	3 : 4	Alchl/Drgs:	0	Speed:	35 MPH	Dir:	N	Veh Mnvr/Ped Actn:				1	Obj Strk:			
152	103508395	21.020	07/29/2012 16:23	REAR END, SLOW OR STOP	\$ 7200	0	0	0	0	1	1	1	1	0	0	
Unit	1 : 4	Alchl/Drgs:	0	Speed:	50 MPH	Dir:	W	Veh Mnvr/Ped Actn:				1	Obj Strk:			
Unit	2 : 5	Alchl/Drgs:	0	Speed:	50 MPH	Dir:	W	Veh Mnvr/Ped Actn:				1	Obj Strk:			
Unit	3 : 5	Alchl/Drgs:	0	Speed:	60 MPH	Dir:	W	Veh Mnvr/Ped Actn:				4	Obj Strk:			
153	102802431	21.060	02/11/2010 18:00	REAR END, SLOW OR STOP	\$ 3500	0	0	0	0	1	1	1	1	0	0	
Unit	1 : 4	Alchl/Drgs:	0	Speed:	20 MPH	Dir:	N	Veh Mnvr/Ped Actn:				11	Obj Strk:			
Unit	2 : 1	Alchl/Drgs:	0	Speed:	20 MPH	Dir:	N	Veh Mnvr/Ped Actn:				4	Obj Strk:			
154	102963834	21.138	09/09/2010 14:57	REAR END, SLOW OR STOP	\$ 550	0	0	0	1	1	1	1	1	0	0	
Unit	1 : 1	Alchl/Drgs:	0	Speed:	55 MPH	Dir:	N	Veh Mnvr/Ped Actn:				4	Obj Strk:			
Unit	2 : 1	Alchl/Drgs:	0	Speed:	55 MPH	Dir:	N	Veh Mnvr/Ped Actn:				11	Obj Strk:			
155	103021331	21.138	10/20/2010 16:20	REAR END, SLOW OR STOP	\$ 2600	0	0	0	0	1	1	1	1	0		
Unit	1 : 1	Alchl/Drgs:	0	Speed:	55 MPH	Dir:	N	Veh Mnvr/Ped Actn:				4	Obj Strk:			
Unit	2 : 1	Alchl/Drgs:	0	Speed:	55 MPH	Dir:	N	Veh Mnvr/Ped Actn:				11	Obj Strk:			
Unit	3 : 1	Alchl/Drgs:	0	Speed:	55 MPH	Dir:	N	Veh Mnvr/Ped Actn:				11	Obj Strk:			
156	102988231	21.171	10/10/2010 20:45	REAR END, SLOW OR STOP	\$ 2000	0	0	0	1	1	5	1	1	0	0	2
Unit	1 : 1	Alchl/Drgs:	1	Speed:	30 MPH	Dir:	E	Veh Mnvr/Ped Actn:				4	Obj Strk:			
Unit	2 : 4	Alchl/Drgs:	0	Speed:	30 MPH	Dir:	E	Veh Mnvr/Ped Actn:				4	Obj Strk:			
157	103011412	21.220	11/12/2010 14:27	REAR END, SLOW OR STOP	\$ 4000	0	0	0	0	1	1	1	1	0	0	
Unit	1 : 1	Alchl/Drgs:	0	Speed:	60 MPH	Dir:	W	Veh Mnvr/Ped Actn:				4	Obj Strk:			
Unit	2 : 4	Alchl/Drgs:	0	Speed:	60 MPH	Dir:	W	Veh Mnvr/Ped Actn:				1	Obj Strk:			
158	103160118	21.310	05/13/2011 15:20	REAR END, SLOW OR STOP	\$ 2000	0	0	0	0	1	1	1	1	0	0	
Unit	1 : 4	Alchl/Drgs:	0	Speed:	20 MPH	Dir:	W	Veh Mnvr/Ped Actn:				4	Obj Strk:			
Unit	2 : 2	Alchl/Drgs:	0	Speed:	20 MPH	Dir:	W	Veh Mnvr/Ped Actn:				11	Obj Strk:			

**North Carolina Department of Transportation
Traffic Engineering Accident Analysis System
Strip Analysis Report**

Acc No	Crash ID	Milepost	Date	Accident Type	Total Damage	Injuries				Condition			Road		Trfc Ctl	
						F	A	B	C	R	L	W	Ch	Ci	Dv	Op
159	103403966	21.310	03/16/2012 15:47	REAR END, SLOW OR STOP	\$ 12500	0	0	0	3	2	1	3	3	0	0	
Unit	1 : 1	Alchl/Drgs:	0	Speed: 60 MPH Dir: W		Veh Mnvr/Ped Actn:				1	Obj Strk:					
Unit	2 : 1	Alchl/Drgs:	0	Speed: 60 MPH Dir: W		Veh Mnvr/Ped Actn:				1	Obj Strk:					
Unit	3 : 4	Alchl/Drgs:	0	Speed: 60 MPH Dir: W		Veh Mnvr/Ped Actn:				4	Obj Strk:					

160	102883418	21.320	06/10/2010 02:08	FIXED OBJECT	\$ 3300	0	0	0	2	1	5	1	1	0	0	
Unit	1 : 1	Alchl/Drgs:	0	Speed: 60 MPH Dir: N		Veh Mnvr/Ped Actn:				4	Obj Strk:		42			

161	103280978	21.320	10/21/2011 07:21	REAR END, SLOW OR STOP	\$ 6700	0	0	0	3	1	1	1	1	0	0	
Unit	1 : 4	Alchl/Drgs:	0	Speed: 60 MPH Dir: S		Veh Mnvr/Ped Actn:				4	Obj Strk:					
Unit	2 : 5	Alchl/Drgs:	0	Speed: 10 MPH Dir: S		Veh Mnvr/Ped Actn:				11	Obj Strk:					
Unit	3 : 1	Alchl/Drgs:	0	Speed: 0 MPH Dir: S		Veh Mnvr/Ped Actn:				1	Obj Strk:					

162	103511870	21.320	07/31/2012 08:15	FIXED OBJECT	\$ 2000	0	0	0	0	2	1	3	3	0	0	
Unit	1 : 1	Alchl/Drgs:	0	Speed: 60 MPH Dir: W		Veh Mnvr/Ped Actn:				4	Obj Strk:		42			

163	103061708	21.390	01/08/2011 14:05	FIXED OBJECT	\$ 1200	0	0	1	1	2	1	4	3	0	0	
Unit	1 : 1	Alchl/Drgs:	0	Speed: 60 MPH Dir: E		Veh Mnvr/Ped Actn:				4	Obj Strk:		59			

164	102742270	21.420	12/12/2009 12:50	REAR END, SLOW OR STOP	\$ 4000	0	0	0	1	1	1	2	1	0	0	
Unit	1 : 1	Alchl/Drgs:	0	Speed: 60 MPH Dir: N		Veh Mnvr/Ped Actn:				4	Obj Strk:					
Unit	2 : 4	Alchl/Drgs:	0	Speed: 60 MPH Dir: N		Veh Mnvr/Ped Actn:				4	Obj Strk:					

165	102757661	21.420	01/02/2010 18:17	RAN OFF ROAD - LEFT	\$ 600	0	0	0	0	1	5	2	1	0	0	
Unit	1 : 1	Alchl/Drgs:	0	Speed: 45 MPH Dir: E		Veh Mnvr/Ped Actn:				4	Obj Strk:		44			

166	102955839	21.420	08/23/2010 00:31	RAN OFF ROAD - LEFT	\$ 1500	0	0	0	0	1	4	1	1	0	0	2
Unit	1 : 4	Alchl/Drgs:	1	Speed: 60 MPH Dir: W		Veh Mnvr/Ped Actn:				4	Obj Strk:					

167	102971476	21.420	09/17/2010 04:48	REAR END, SLOW OR STOP	\$ 1500	0	0	0	0	1	5	3	1	0	0	2
Unit	1 : 1	Alchl/Drgs:	0	Speed: 40 MPH Dir: W		Veh Mnvr/Ped Actn:				4	Obj Strk:					
Unit	2 : 1	Alchl/Drgs:	0	Speed: 30 MPH Dir: W		Veh Mnvr/Ped Actn:				4	Obj Strk:					

168	103299445	21.439	11/10/2011 18:05	REAR END, SLOW OR STOP	\$ 1100	0	0	0	0	1	5	1	1	0	0	
Unit	1 : 1	Alchl/Drgs:	0	Speed: 35 MPH Dir: SE		Veh Mnvr/Ped Actn:				11	Obj Strk:					
Unit	2 : 1	Alchl/Drgs:	0	Speed: 15 MPH Dir: SE		Veh Mnvr/Ped Actn:				11	Obj Strk:					

**North Carolina Department of Transportation
Traffic Engineering Accident Analysis System
Strip Analysis Report**

Acc No	Crash ID	Milepost	Date	Accident Type	Total Damage	Injuries				Condition			Road		Trfc Ctl	
						F	A	B	C	R	L	W	Ch	Ci	Dv	Op
169	103459084	21.440	05/24/2012 23:36	OTHER COLLISION WITH VEHICLE	\$ 1600	0	0	0	0	1	5	1	1	0	0	
Unit	1 : 1	Alchl/Drugs:	0	Speed:	60 MPH Dir: W	Veh Mnvr/Ped Actn:				4	Obj Strk:					
Unit	2 : 1	Alchl/Drugs:	7	Speed:	60 MPH Dir: W	Veh Mnvr/Ped Actn:				4	Obj Strk:					
170	103403633	21.480	03/16/2012 15:56	REAR END, SLOW OR STOP	\$ 8200	0	0	0	0	2	1	3	1	0	0	
Unit	1 : 4	Alchl/Drugs:	0	Speed:	60 MPH Dir: W	Veh Mnvr/Ped Actn:				4	Obj Strk:					
Unit	2 : 2	Alchl/Drugs:	7	Speed:	60 MPH Dir: W	Veh Mnvr/Ped Actn:				5	Obj Strk:					
171	102914255	21.490	07/16/2010 04:22	RAN OFF ROAD - RIGHT	\$ 34500	0	0	0	0	1	5	1	8	0	0	
Unit	1 : 14	Alchl/Drugs:	0	Speed:	60 MPH Dir: E	Veh Mnvr/Ped Actn:				4	Obj Strk:					
172	102651619	21.510	08/10/2009 22:29	REAR END, SLOW OR STOP	\$ 8000	0	0	0	0	1	5	1	1	0	0	
Unit	1 : 15	Alchl/Drugs:	0	Speed:	0 MPH Dir: E	Veh Mnvr/Ped Actn:				1	Obj Strk:					
Unit	2 : 1	Alchl/Drugs:	1	Speed:	70 MPH Dir: E	Veh Mnvr/Ped Actn:				4	Obj Strk:					
173	102855256	21.510	04/14/2010 11:41	REAR END, SLOW OR STOP	\$ 13000	0	0	0	0	1	1	1	1	0	10	1
Unit	1 : 4	Alchl/Drugs:	0	Speed:	40 MPH Dir: SE	Veh Mnvr/Ped Actn:				11	Obj Strk:					
Unit	2 : 1	Alchl/Drugs:	0	Speed:	25 MPH Dir: SE	Veh Mnvr/Ped Actn:				11	Obj Strk:		44			
174	102897986	21.510	06/25/2010 16:22	REAR END, SLOW OR STOP	\$ 1000	0	0	0	0	1	1	1	1	0	0	
Unit	1 : 1	Alchl/Drugs:	0	Speed:	35 MPH Dir: E	Veh Mnvr/Ped Actn:				4	Obj Strk:					
Unit	2 : 2	Alchl/Drugs:	0	Speed:	5 MPH Dir: E	Veh Mnvr/Ped Actn:				1	Obj Strk:					
175	102925444	21.510	07/30/2010 19:44	REAR END, SLOW OR STOP	\$ 1600	0	0	0	0	1	1	1	1	0	0	
Unit	1 : 1	Alchl/Drugs:	0	Speed:	20 MPH Dir: W	Veh Mnvr/Ped Actn:				4	Obj Strk:					
Unit	2 : 1	Alchl/Drugs:	0	Speed:	5 MPH Dir: W	Veh Mnvr/Ped Actn:				1	Obj Strk:					
176	102949203	21.510	08/21/2010 14:26	REAR END, SLOW OR STOP	\$ 3100	0	0	0	0	2	1	3	1	0	0	
Unit	1 : 1	Alchl/Drugs:	0	Speed:	25 MPH Dir: W	Veh Mnvr/Ped Actn:				4	Obj Strk:					
Unit	2 : 2	Alchl/Drugs:	0	Speed:	0 MPH Dir: W	Veh Mnvr/Ped Actn:				4	Obj Strk:					
177	102961637	21.510	09/15/2010 06:45	REAR END, SLOW OR STOP	\$ 5000	0	0	0	0	1	3	1	1	0	0	
Unit	1 : 12	Alchl/Drugs:	0	Speed:	40 MPH Dir: E	Veh Mnvr/Ped Actn:				4	Obj Strk:					
Unit	2 : 1	Alchl/Drugs:	0	Speed:	40 MPH Dir: E	Veh Mnvr/Ped Actn:				4	Obj Strk:					
178	103317205	21.510	11/30/2011 21:53	RAN OFF ROAD - LEFT	\$ 6500	0	0	0	1	1	5	1	1	0	0	
Unit	1 : 4	Alchl/Drugs:	0	Speed:	60 MPH Dir: S	Veh Mnvr/Ped Actn:				4	Obj Strk:					

**North Carolina Department of Transportation
Traffic Engineering Accident Analysis System
Strip Analysis Report**

Acc No	Crash ID	Milepost	Date	Accident Type	Total Damage	Injuries				Condition			Road		Trfc Ctl	
						F	A	B	C	R	L	W	Ch	Ci	Dv	Op
179	103417563	21.510	04/03/2012 15:35	FIXED OBJECT	\$ 3000	0	0	0	1	2	1	2	5	0	0	
Unit	1 : 1	Alchl/Drgs:	0	Speed:	60 MPH Dir: SE	Veh Mnvr/Ped Actn:				4	Obj Strk:		42			
180	102862354	21.520	05/12/2010 09:05	REAR END, SLOW OR STOP	\$ 4500	0	0	0	0	1	1	1	1	0	0	
Unit	1 : 2	Alchl/Drgs:	0	Speed:	45 MPH Dir: NW	Veh Mnvr/Ped Actn:				11	Obj Strk:					
Unit	2 : 2	Alchl/Drgs:	0	Speed:	45 MPH Dir: NW	Veh Mnvr/Ped Actn:				4	Obj Strk:					
181	103097490	21.520	02/23/2011 11:55	MOVABLE OBJECT	\$ 2500	0	0	0	0	1	1	1	3	0	0	
Unit	1 : 10	Alchl/Drgs:	0	Speed:	50 MPH Dir: N	Veh Mnvr/Ped Actn:				4	Obj Strk:					
Unit	2 : 31	Alchl/Drgs:	0	Speed:	60 MPH Dir: N	Veh Mnvr/Ped Actn:				4	Obj Strk:		18			
182	103221163	21.520	08/07/2011 14:10	REAR END, SLOW OR STOP	\$ 410	0	0	0	0	1	1	1	1	0	0	
Unit	1 : 2	Alchl/Drgs:	0	Speed:	10 MPH Dir: W	Veh Mnvr/Ped Actn:				4	Obj Strk:					
Unit	2 : 1	Alchl/Drgs:	0	Speed:	0 MPH Dir: W	Veh Mnvr/Ped Actn:				1	Obj Strk:					
183	103284420	21.520	10/21/2011 07:20	REAR END, SLOW OR STOP	\$ 1500	0	0	0	0	1	1	1	3	0	0	
Unit	1 : 1	Alchl/Drgs:	0	Speed:	45 MPH Dir: E	Veh Mnvr/Ped Actn:				4	Obj Strk:					
Unit	2 : 1	Alchl/Drgs:	0	Speed:	0 MPH Dir: E	Veh Mnvr/Ped Actn:				1	Obj Strk:					
184	103281334	21.520	10/21/2011 07:35	REAR END, SLOW OR STOP	\$ 3500	0	0	0	0	1	1	1	3	0	0	
Unit	1 : 1	Alchl/Drgs:	0	Speed:	50 MPH Dir: E	Veh Mnvr/Ped Actn:				4	Obj Strk:					
Unit	2 : 1	Alchl/Drgs:	0	Speed:	50 MPH Dir: E	Veh Mnvr/Ped Actn:				4	Obj Strk:					
185	103471375	21.520	06/09/2012 14:40	REAR END, SLOW OR STOP	\$ 2500	0	0	0	0	1	1	1	1	0	0	
Unit	1 : 2	Alchl/Drgs:	0	Speed:	50 MPH Dir: N	Veh Mnvr/Ped Actn:				1	Obj Strk:					
Unit	2 : 5	Alchl/Drgs:	0	Speed:	50 MPH Dir: N	Veh Mnvr/Ped Actn:				4	Obj Strk:					
186	103197829	21.540	07/08/2011 19:05	REAR END, SLOW OR STOP	\$ 1800	0	0	0	0	1	1	1	1	0	0	
Unit	1 : 5	Alchl/Drgs:	0	Speed:	40 MPH Dir: W	Veh Mnvr/Ped Actn:				11	Obj Strk:					
Unit	2 : 3	Alchl/Drgs:	0	Speed:	60 MPH Dir: W	Veh Mnvr/Ped Actn:				1	Obj Strk:					
187	103120130	21.560	03/06/2011 19:50	SIDESWIPE, SAME DIRECTION	\$ 305	0	0	0	0	1	5	2	1	0	0	
Unit	1 : 14	Alchl/Drgs:	0	Speed:	65 MPH Dir: W	Veh Mnvr/Ped Actn:				5	Obj Strk:					
Unit	2 : 4	Alchl/Drgs:	0	Speed:	60 MPH Dir: W	Veh Mnvr/Ped Actn:				4	Obj Strk:					

**North Carolina Department of Transportation
Traffic Engineering Accident Analysis System
Strip Analysis Report**

Acc No	Crash ID	Milepost	Date	Accident Type	Total Damage	Injuries				Condition			Road		Trfc Ctl	
						F	A	B	C	R	L	W	Ch	Ci	Dv	Op
188	102907481	21.580	07/08/2010 17:36	REAR END, SLOW OR STOP	\$ 2500	0	0	0	0	1	1	1	1	0	0	
Unit	1 : 1	Alchl/Drgs:	0	Speed: 45 MPH Dir: E		Veh Mnvr/Ped Actn:				4	Obj Strk:					
Unit	2 : 1	Alchl/Drgs:	0	Speed: 45 MPH Dir: E		Veh Mnvr/Ped Actn:				4	Obj Strk:					
189	102789352	21.600	02/11/2010 14:49	SIDESWIPE, SAME DIRECTION	\$ 1200	0	0	0	0	1	1	1	5	0	0	
Unit	1 : 14	Alchl/Drgs:	0	Speed: 55 MPH Dir: S		Veh Mnvr/Ped Actn:				5	Obj Strk:					
Unit	2 : 4	Alchl/Drgs:	0	Speed: 60 MPH Dir: S		Veh Mnvr/Ped Actn:				4	Obj Strk:					
190	102658727	21.610	08/11/2009 18:00	REAR END, SLOW OR STOP	\$ 3900	0	0	0	1	1	1	2	1	0	0	
Unit	1 : 2	Alchl/Drgs:	0	Speed: 40 MPH Dir: E		Veh Mnvr/Ped Actn:				11	Obj Strk:					
Unit	2 : 2	Alchl/Drgs:	0	Speed: 40 MPH Dir: E		Veh Mnvr/Ped Actn:				4	Obj Strk:					
191	102674911	21.610	09/17/2009 08:30	REAR END, SLOW OR STOP	\$ 3000	0	0	0	0	2	1	3	3	0	0	
Unit	1 : 1	Alchl/Drgs:	0	Speed: 35 MPH Dir: W		Veh Mnvr/Ped Actn:				4	Obj Strk:					
Unit	2 : 4	Alchl/Drgs:	0	Speed: 0 MPH Dir: W		Veh Mnvr/Ped Actn:				1	Obj Strk:					
192	102752573	21.620	12/16/2009 18:29	RAN OFF ROAD - RIGHT	\$ 3500	0	0	0	0	1	2	1	1	0	0	
Unit	1 : 1	Alchl/Drgs:	0	Speed: 55 MPH Dir: S		Veh Mnvr/Ped Actn:				4	Obj Strk:		48			
193	102897729	21.620	06/25/2010 14:00	SIDESWIPE, SAME DIRECTION	\$ 9150	0	0	0	0	1	1	2	1	0	0	
Unit	1 : 11	Alchl/Drgs:	0	Speed: 45 MPH Dir: NW		Veh Mnvr/Ped Actn:				4	Obj Strk:					
Unit	2 : 4	Alchl/Drgs:	0	Speed: 45 MPH Dir: NW		Veh Mnvr/Ped Actn:				4	Obj Strk:					
194	102917753	21.620	07/20/2010 14:40	REAR END, SLOW OR STOP	\$ 75	0	0	0	1	1	1	1	3	0	0	
Unit	1 : 14	Alchl/Drgs:	0	Speed: 3 MPH Dir: E		Veh Mnvr/Ped Actn:				12	Obj Strk:					
Unit	2 : 3	Alchl/Drgs:	0	Speed: 0 MPH Dir: E		Veh Mnvr/Ped Actn:				1	Obj Strk:					
195	103159528	21.620	05/18/2011 14:01	SIDESWIPE, SAME DIRECTION	\$ 5000	0	0	0	0	1	1	2	3	0	0	
Unit	1 : 5	Alchl/Drgs:	0	Speed: 60 MPH Dir: W		Veh Mnvr/Ped Actn:				4	Obj Strk:					
Unit	2 : 2	Alchl/Drgs:	0	Speed: 60 MPH Dir: W		Veh Mnvr/Ped Actn:				4	Obj Strk:					
196	103200811	21.620	07/14/2011 14:24	REAR END, SLOW OR STOP	\$ 950	0	0	0	0	1	1	1	1	0	0	
Unit	1 : 14	Alchl/Drgs:	0	Speed: 60 MPH Dir: N		Veh Mnvr/Ped Actn:				4	Obj Strk:					
Unit	2 : 4	Alchl/Drgs:	0	Speed: 60 MPH Dir: N		Veh Mnvr/Ped Actn:				11	Obj Strk:					
197	103294093	21.620	11/05/2011 19:56	MOVABLE OBJECT	\$ 6800	0	0	0	0	1	5	1	1	2	0	
Unit	1 : 14	Alchl/Drgs:	0	Speed: 60 MPH Dir: E		Veh Mnvr/Ped Actn:				4	Obj Strk:					

**North Carolina Department of Transportation
Traffic Engineering Accident Analysis System
Strip Analysis Report**

Acc No	Crash ID	Milepost	Date	Accident Type	Total Damage	Injuries				Condition			Road		Trfc Ctl	
						F	A	B	C	R	L	W	Ch	Ci	Dv	Op
Unit	2 : 1	Alchl/Drugs:	0	Speed:	60 MPH Dir: E	Veh Mnvr/Ped Actn:				4	Obj Strk:		18			
Unit	3 : 5	Alchl/Drugs:	0	Speed:	60 MPH Dir: E	Veh Mnvr/Ped Actn:				4	Obj Strk:		18			
Unit	4 : 4	Alchl/Drugs:	0	Speed:	60 MPH Dir: E	Veh Mnvr/Ped Actn:				4	Obj Strk:		18			
198	103392407	21.620	03/02/2012 20:07	FIXED OBJECT	\$ 1400	0	0	0	0	1	5	2	1	0	0	
Unit	1 : 4	Alchl/Drugs:	0	Speed:	60 MPH Dir: N	Veh Mnvr/Ped Actn:				15	Obj Strk:		44			
199	103455669	21.620	05/18/2012 15:00	REAR END, SLOW OR STOP	\$ 3300	0	0	0	0	1	1	1	1	0	0	
Unit	1 : 1	Alchl/Drugs:	0	Speed:	50 MPH Dir: W	Veh Mnvr/Ped Actn:				4	Obj Strk:					
Unit	2 : 1	Alchl/Drugs:	0	Speed:	0 MPH Dir: W	Veh Mnvr/Ped Actn:				11	Obj Strk:					
200	102988379	21.720	10/14/2010 12:10	SIDESWIPE, SAME DIRECTION	\$ 13000	0	0	0	1	1	1	2	3	0	0	
Unit	1 : 25	Alchl/Drugs:	0	Speed:	60 MPH Dir: W	Veh Mnvr/Ped Actn:				5	Obj Strk:					
Unit	2 : 4	Alchl/Drugs:	0	Speed:	60 MPH Dir: W	Veh Mnvr/Ped Actn:				4	Obj Strk:					
201	103166263	21.820	05/27/2011 16:33	REAR END, SLOW OR STOP	\$ 11000	0	0	0	1	1	1	1	3	0	0	
Unit	1 : 4	Alchl/Drugs:	0	Speed:	60 MPH Dir: W	Veh Mnvr/Ped Actn:				4	Obj Strk:					
Unit	2 : 4	Alchl/Drugs:	0	Speed:	60 MPH Dir: W	Veh Mnvr/Ped Actn:				1	Obj Strk:					
Unit	3 : 1	Alchl/Drugs:	0	Speed:	60 MPH Dir: W	Veh Mnvr/Ped Actn:				1	Obj Strk:					
202	103470805	21.882	06/08/2012 16:18	REAR END, SLOW OR STOP	\$ 900	0	0	0	0	1	1	1	1	0	0	
Unit	1 : 2	Alchl/Drugs:	0	Speed:	30 MPH Dir: W	Veh Mnvr/Ped Actn:				1	Obj Strk:					
Unit	2 : 2	Alchl/Drugs:	0	Speed:	30 MPH Dir: W	Veh Mnvr/Ped Actn:				4	Obj Strk:					
203	103487391	21.910	06/29/2012 03:53	OVERTURN/ROLLOVER	\$ 15500	0	0	1	0	1	5	1	1	0	0	
Unit	1 : 2	Alchl/Drugs:	1	Speed:	60 MPH Dir: S	Veh Mnvr/Ped Actn:				4	Obj Strk:		42			
204	102980991	21.920	10/09/2010 21:29	ANIMAL	\$ 2500	0	0	0	0	1	5	1	1	0	0	
Unit	1 : 2	Alchl/Drugs:	0	Speed:	60 MPH Dir: W	Veh Mnvr/Ped Actn:				4	Obj Strk:		17			
205	103062262	21.920	01/03/2011 16:20	FIXED OBJECT	\$ 5000	0	0	0	0	1	5	1	1	0	0	
Unit	1 : 4	Alchl/Drugs:	0	Speed:	60 MPH Dir: E	Veh Mnvr/Ped Actn:				5	Obj Strk:		42			
206	103129586	21.920	04/06/2011 07:42	REAR END, SLOW OR STOP	\$ 18500	0	0	0	3	1	1	1	1	0	0	
Unit	1 : 2	Alchl/Drugs:	0	Speed:	35 MPH Dir: W	Veh Mnvr/Ped Actn:				4	Obj Strk:					
Unit	2 : 1	Alchl/Drugs:	0	Speed:	25 MPH Dir: W	Veh Mnvr/Ped Actn:				11	Obj Strk:		44			
Unit	3 : 1	Alchl/Drugs:	0	Speed:	20 MPH Dir: W	Veh Mnvr/Ped Actn:				11	Obj Strk:					
Unit	4 : 1	Alchl/Drugs:	0	Speed:	10 MPH Dir: W	Veh Mnvr/Ped Actn:				11	Obj Strk:					

**North Carolina Department of Transportation
Traffic Engineering Accident Analysis System
Strip Analysis Report**

Acc No	Crash ID	Milepost	Date	Accident Type	Total Damage	Injuries				Condition			Road		Trfc Ctl	
						F	A	B	C	R	L	W	Ch	Ci	Dv	Op
207	103252721	21.920	09/15/2011 11:50	MOVABLE OBJECT	\$ 250	0	0	0	0	1	1	2	1	0	0	
Unit	1 : 2	Alchl/Drgs:	0	Speed:	60 MPH	Dir:	W	Veh Mnvr/Ped Actn:				4	Obj Strk:		18	
208	103476236	21.920	06/15/2012 15:55	FIXED OBJECT	\$ 4000	0	0	0	0	1	1	1	1	0	0	
Unit	1 : 1	Alchl/Drgs:	0	Speed:	60 MPH	Dir:	N	Veh Mnvr/Ped Actn:				4	Obj Strk:		42	
209	103493568	21.920	07/06/2012 19:09	REAR END, SLOW OR STOP	\$ 2500	0	0	0	0	1	1	1	1	0	0	
Unit	1 : 2	Alchl/Drgs:	3	Speed:	55 MPH	Dir:	W	Veh Mnvr/Ped Actn:				4	Obj Strk:			
Unit	2 : 1	Alchl/Drgs:	0	Speed:	60 MPH	Dir:	W	Veh Mnvr/Ped Actn:				4	Obj Strk:			
210	103235582	21.960	08/25/2011 07:45	REAR END, SLOW OR STOP	\$ 11000	0	0	0	1	1	1	1	1	0	0	
Unit	1 : 2	Alchl/Drgs:	0	Speed:	25 MPH	Dir:	E	Veh Mnvr/Ped Actn:				4	Obj Strk:			
Unit	2 : 1	Alchl/Drgs:	0	Speed:	15 MPH	Dir:	E	Veh Mnvr/Ped Actn:				4	Obj Strk:			
Unit	3 : 1	Alchl/Drgs:	0	Speed:	0 MPH	Dir:	E	Veh Mnvr/Ped Actn:				1	Obj Strk:			
211	102880028	22.010	06/04/2010 16:47	REAR END, SLOW OR STOP	\$ 2500	0	0	1	0	1	1	1	1	0	0	
Unit	1 : 20	Alchl/Drgs:	0	Speed:	25 MPH	Dir:	W	Veh Mnvr/Ped Actn:				4	Obj Strk:			
Unit	2 : 1	Alchl/Drgs:	0	Speed:	25 MPH	Dir:	W	Veh Mnvr/Ped Actn:				11	Obj Strk:			
212	102778898	22.020	01/29/2010 17:00	SIDESWIPE, SAME DIRECTION	\$ 4500	0	0	0	0	5	5	4	1	0	0	
Unit	1 : 10	Alchl/Drgs:	0	Speed:	20 MPH	Dir:	SE	Veh Mnvr/Ped Actn:				4	Obj Strk:			
Unit	2 : 2	Alchl/Drgs:	0	Speed:	5 MPH	Dir:	SE	Veh Mnvr/Ped Actn:				4	Obj Strk:			
213	102984984	22.020	10/13/2010 19:50	REAR END, SLOW OR STOP	\$ 5025	0	0	0	0	1	5	1	1	0	0	
Unit	1 : 1	Alchl/Drgs:	0	Speed:	40 MPH	Dir:	E	Veh Mnvr/Ped Actn:				1	Obj Strk:			
Unit	2 : 1	Alchl/Drgs:	0	Speed:	40 MPH	Dir:	E	Veh Mnvr/Ped Actn:				11	Obj Strk:			
Unit	3 : 1	Alchl/Drgs:	0	Speed:	50 MPH	Dir:	E	Veh Mnvr/Ped Actn:				4	Obj Strk:			
214	103196323	22.020	07/09/2011 12:55	SIDESWIPE, SAME DIRECTION	\$ 6000	0	0	0	0	1	1	1	1	0	0	
Unit	1 : 5	Alchl/Drgs:	0	Speed:	60 MPH	Dir:	N	Veh Mnvr/Ped Actn:				4	Obj Strk:		44	
Unit	2 : 4	Alchl/Drgs:	0	Speed:	50 MPH	Dir:	N	Veh Mnvr/Ped Actn:				4	Obj Strk:			
215	103485004	22.020	06/24/2012 13:30	REAR END, SLOW OR STOP	\$ 17700	0	0	0	0	1	1	1	1	0	0	
Unit	1 : 4	Alchl/Drgs:	0	Speed:	45 MPH	Dir:	W	Veh Mnvr/Ped Actn:				4	Obj Strk:		44	
Unit	2 : 1	Alchl/Drgs:	0	Speed:	5 MPH	Dir:	W	Veh Mnvr/Ped Actn:				11	Obj Strk:			
Unit	3 : 2	Alchl/Drgs:	0	Speed:	0 MPH	Dir:	W	Veh Mnvr/Ped Actn:				11	Obj Strk:			
Unit	4 : 1	Alchl/Drgs:	0	Speed:	0 MPH	Dir:	W	Veh Mnvr/Ped Actn:				11	Obj Strk:			

**North Carolina Department of Transportation
Traffic Engineering Accident Analysis System
Strip Analysis Report**

Acc No	Crash ID	Milepost	Date	Accident Type	Total Damage	Injuries				Condition			Road		Trfc Ctl	
						F	A	B	C	R	L	W	Ch	Ci	Dv	Op
216	103143869	22.040	04/26/2011 08:05	FIXED OBJECT	\$ 6500	0	0	0	0	1	1	2	1	0	0	
Unit	1 : 1	Alchl/Drgs:	0	Speed: 60 MPH Dir: W		Veh Mnvr/Ped Actn:				4	Obj Strk:		42			
217	102680235	22.090	09/21/2009 08:15	REAR END, SLOW OR STOP	\$ 6000	0	0	0	0	2	1	3	1	0	0	
Unit	1 : 1	Alchl/Drgs:	0	Speed: 45 MPH Dir: W		Veh Mnvr/Ped Actn:				4	Obj Strk:					
Unit	2 : 1	Alchl/Drgs:	0	Speed: 50 MPH Dir: W		Veh Mnvr/Ped Actn:				4	Obj Strk:					
218	103190354	22.120	06/30/2011 18:03	RAN OFF ROAD - LEFT	\$ 1000	0	0	0	0	1	1	1	1	0	0	
Unit	1 : 1	Alchl/Drgs:	0	Speed: 60 MPH Dir: E		Veh Mnvr/Ped Actn:				4	Obj Strk:		42			
219	103237059	22.120	08/27/2011 03:30	FIXED OBJECT	\$ 4100	0	0	0	0	1	5	1	1	0	0	
Unit	1 : 1	Alchl/Drgs:	0	Speed: 60 MPH Dir: W		Veh Mnvr/Ped Actn:				4	Obj Strk:		44			
Unit	2 : 4	Alchl/Drgs:	0	Speed: 60 MPH Dir: W		Veh Mnvr/Ped Actn:				4	Obj Strk:					
220	103338917	22.120	12/27/2011 12:57	REAR END, SLOW OR STOP	\$ 2300	0	0	0	0	1	1	2	1	0	0	
Unit	1 : 4	Alchl/Drgs:	0	Speed: 5 MPH Dir: S		Veh Mnvr/Ped Actn:				11	Obj Strk:					
Unit	2 : 1	Alchl/Drgs:	0	Speed: 25 MPH Dir: S		Veh Mnvr/Ped Actn:				11	Obj Strk:					
221	103391175	22.220	03/01/2012 11:30	MOVABLE OBJECT	\$ 100	0	0	0	0	1	1	1	1	0	0	
Unit	1 : 4	Alchl/Drgs:	0	Speed: 60 MPH Dir: W		Veh Mnvr/Ped Actn:				4	Obj Strk:		18			
222	102975723	22.320	10/02/2010 21:33	REAR END, SLOW OR STOP	\$ 4300	0	0	0	0	1	5	1	1	0	0	
Unit	1 : 2	Alchl/Drgs:	0	Speed: 15 MPH Dir: E		Veh Mnvr/Ped Actn:				4	Obj Strk:					
Unit	2 : 1	Alchl/Drgs:	0	Speed: 15 MPH Dir: E		Veh Mnvr/Ped Actn:				11	Obj Strk:					
223	102993756	22.320	10/22/2010 14:34	REAR END, SLOW OR STOP	\$ 2000	0	0	0	0	1	1	1	3	0	0	
Unit	1 : 5	Alchl/Drgs:	0	Speed: 50 MPH Dir: W		Veh Mnvr/Ped Actn:				4	Obj Strk:					
Unit	2 : 2	Alchl/Drgs:	0	Speed: 50 MPH Dir: W		Veh Mnvr/Ped Actn:				4	Obj Strk:					
224	103046146	22.320	12/19/2010 18:49	REAR END, TURN	\$ 4000	0	0	0	1	1	5	1	1	0	0	
Unit	1 : 12	Alchl/Drgs:	0	Speed: 55 MPH Dir: W		Veh Mnvr/Ped Actn:				4	Obj Strk:					
Unit	2 : 29	Alchl/Drgs:	0	Speed: 50 MPH Dir: W		Veh Mnvr/Ped Actn:				8	Obj Strk:					
225	103284422	22.320	10/21/2011 14:45	REAR END, SLOW OR STOP	\$ 6500	0	0	0	2	1	1	1	3	0	0	
Unit	1 : 2	Alchl/Drgs:	0	Speed: 60 MPH Dir: W		Veh Mnvr/Ped Actn:				4	Obj Strk:					
Unit	2 : 4	Alchl/Drgs:	0	Speed: 0 MPH Dir: W		Veh Mnvr/Ped Actn:				1	Obj Strk:					

**North Carolina Department of Transportation
Traffic Engineering Accident Analysis System
Strip Analysis Report**

Acc No	Crash ID	Milepost	Date	Accident Type	Total Damage	Injuries				Condition			Road		Trfc Ctl	
						F	A	B	C	R	L	W	Ch	Ci	Dv	Op
226	103126456	22.390	04/02/2011 12:00	REAR END, SLOW OR STOP	\$ 4000	0	0	0	0	1	1	1	1	0	0	
Unit	1 : 4	Alchl/Drgs:	0	Speed: 60 MPH Dir: S		Veh Mnvr/Ped Actn:				11	Obj Strk:					
Unit	2 : 2	Alchl/Drgs:	0	Speed: 60 MPH Dir: S		Veh Mnvr/Ped Actn:				4	Obj Strk:					
227	103387228	22.410	02/23/2012 09:34	REAR END, SLOW OR STOP	\$ 5700	0	0	0	0	1	1	1	1	0	0	
Unit	1 : 2	Alchl/Drgs:	0	Speed: 65 MPH Dir: W		Veh Mnvr/Ped Actn:				4	Obj Strk:					
Unit	2 : 10	Alchl/Drgs:	0	Speed: 40 MPH Dir: W		Veh Mnvr/Ped Actn:				1	Obj Strk:					
228	102661037	22.420	08/26/2009 11:57	REAR END, SLOW OR STOP	\$ 2700	0	0	0	0	1	1	1	1	0	0	
Unit	1 : 1	Alchl/Drgs:	0	Speed: 60 MPH Dir: E		Veh Mnvr/Ped Actn:				4	Obj Strk:					
Unit	2 : 1	Alchl/Drgs:	0	Speed: 60 MPH Dir: E		Veh Mnvr/Ped Actn:				4	Obj Strk:					
Unit	3 : 4	Alchl/Drgs:	0	Speed: 55 MPH Dir: E		Veh Mnvr/Ped Actn:				4	Obj Strk:					
229	102993819	22.420	10/24/2010 14:43	SIDESWIPE, SAME DIRECTION	\$ 9000	0	0	1	0	1	1	1	1	0	0	
Unit	1 : 20	Alchl/Drgs:	0	Speed: 55 MPH Dir: E		Veh Mnvr/Ped Actn:				4	Obj Strk:					
Unit	2 : 4	Alchl/Drgs:	0	Speed: 55 MPH Dir: E		Veh Mnvr/Ped Actn:				4	Obj Strk:					
230	102997974	22.420	10/28/2010 19:17	REAR END, SLOW OR STOP	\$ 1000	0	0	0	1	1	6	1	3	0	0	
Unit	1 : 4	Alchl/Drgs:	0	Speed: 15 MPH Dir: W		Veh Mnvr/Ped Actn:				4	Obj Strk:					
Unit	2 : 1	Alchl/Drgs:	0	Speed: 15 MPH Dir: W		Veh Mnvr/Ped Actn:				4	Obj Strk:					
231	103181104	22.420	06/18/2011 14:50	REAR END, SLOW OR STOP	\$ 12900	0	0	0	1	2	1	3	1	0	0	
Unit	1 : 2	Alchl/Drgs:	0	Speed: 45 MPH Dir: W		Veh Mnvr/Ped Actn:				4	Obj Strk:					
Unit	2 : 1	Alchl/Drgs:	0	Speed: 0 MPH Dir: W		Veh Mnvr/Ped Actn:				4	Obj Strk:					
Unit	3 : 1	Alchl/Drgs:	0	Speed: 0 MPH Dir: W		Veh Mnvr/Ped Actn:				4	Obj Strk:					
Unit	4 : 3	Alchl/Drgs:	0	Speed: 0 MPH Dir: W		Veh Mnvr/Ped Actn:				4	Obj Strk:					
232	103234251	22.420	08/22/2011 17:48	SIDESWIPE, SAME DIRECTION	\$ 1050	0	0	0	0	1	1	1	1	0	0	
Unit	1 : 14	Alchl/Drgs:	0	Speed: 50 MPH Dir: W		Veh Mnvr/Ped Actn:				4	Obj Strk:					
Unit	2 : 2	Alchl/Drgs:	7	Speed: 60 MPH Dir: W		Veh Mnvr/Ped Actn:				4	Obj Strk:					
233	103282168	22.420	10/23/2011 02:30	FIXED OBJECT	\$ 6000	0	0	1	0	1	5	1	3	0	0	
Unit	1 : 2	Alchl/Drgs:	0	Speed: 60 MPH Dir: E		Veh Mnvr/Ped Actn:				4	Obj Strk:		59			
234	102887814	22.450	06/11/2010 09:00	FIXED OBJECT	\$ 3500	0	0	0	0	1	1	1	7	0	0	
Unit	1 : 2	Alchl/Drgs:	0	Speed: 60 MPH Dir: E		Veh Mnvr/Ped Actn:				4	Obj Strk:		48			

**North Carolina Department of Transportation
Traffic Engineering Accident Analysis System
Strip Analysis Report**

Acc No	Crash ID	Milepost	Date	Accident Type	Total Damage	Injuries				Condition			Road		Trfc Ctl		
						F	A	B	C	R	L	W	Ch	Ci	Dv	Op	
235	102951805	22.450	08/31/2010 14:00	FIXED OBJECT	\$ 1050	0	0	0	0	1	1	1	1	0	0		
Unit	1 : 1	Alchl/Drugs:	0	Speed:	60 MPH Dir: E	Veh Mnvr/Ped Actn:				4	Obj Strk:		49				
236	103134173	22.450	04/06/2011 07:15	REAR END, SLOW OR STOP	\$ 4000	0	0	0	0	1	1	1	1	0			
Unit	1 : 1	Alchl/Drugs:	0	Speed:	70 MPH Dir: E	Veh Mnvr/Ped Actn:				16	Obj Strk:		33				
Unit	2 : 1	Alchl/Drugs:	0	Speed:	70 MPH Dir: E	Veh Mnvr/Ped Actn:				4	Obj Strk:						
237	103294104	22.450	11/05/2011 19:55	MOVABLE OBJECT	\$ 2000	0	0	0	0	1	5	1	1	0	0		
Unit	1 : 14	Alchl/Drugs:	0	Speed:	60 MPH Dir: E	Veh Mnvr/Ped Actn:				4	Obj Strk:		18				
238	102813104	22.510	03/10/2010 14:03	MOVABLE OBJECT	\$ 1000	0	0	0	0	1	1	2	1	0	0		
Unit	1 : 1	Alchl/Drugs:	0	Speed:	60 MPH Dir: S	Veh Mnvr/Ped Actn:				4	Obj Strk:		18				
239	102826428	22.510	03/20/2010 12:14	OTHER NON-COLLISION	\$ 800	0	0	0	0	1	1	1	1	0	0		
Unit	1 : 1	Alchl/Drugs:	0	Speed:	60 MPH Dir: W	Veh Mnvr/Ped Actn:				4	Obj Strk:						
240	102846937	22.510	04/23/2010 17:47	SIDESWIPE, SAME DIRECTION	\$ 900	0	1	0	0	1	1	1	1	0	0		
Unit	1 : 1	Alchl/Drugs:	0	Speed:	40 MPH Dir: E	Veh Mnvr/Ped Actn:				11	Obj Strk:						
Unit	2 : 20	Alchl/Drugs:	0	Speed:	40 MPH Dir: E	Veh Mnvr/Ped Actn:				4	Obj Strk:						
241	102856611	22.510	05/05/2010 08:29	REAR END, SLOW OR STOP	\$ 1000	0	0	0	0	1	1	1	1	0	0		
Unit	1 : 1	Alchl/Drugs:	0	Speed:	60 MPH Dir: W	Veh Mnvr/Ped Actn:				4	Obj Strk:						
Unit	2 : 2	Alchl/Drugs:	0	Speed:	60 MPH Dir: W	Veh Mnvr/Ped Actn:				11	Obj Strk:						
242	102966694	22.520	09/22/2010 00:54	FIXED OBJECT	\$ 6500	0	0	0	0	1	5	1	7	0	0		
Unit	1 : 4	Alchl/Drugs:	1	Speed:	70 MPH Dir: E	Veh Mnvr/Ped Actn:				4	Obj Strk:		59				
243	102992785	22.520	10/21/2010 23:15	SIDESWIPE, SAME DIRECTION	\$ 1700	0	0	0	1	1	5	1	1	0	0		
Unit	1 : 12	Alchl/Drugs:	0	Speed:	20 MPH Dir: W	Veh Mnvr/Ped Actn:				4	Obj Strk:						
Unit	2 : 1	Alchl/Drugs:	0	Speed:	20 MPH Dir: W	Veh Mnvr/Ped Actn:				4	Obj Strk:						
244	103043516	22.520	12/16/2010 17:57	REAR END, SLOW OR STOP	\$ 4300	0	0	0	0	2	5	2	1	0	0		
Unit	1 : 2	Alchl/Drugs:	0	Speed:	50 MPH Dir: W	Veh Mnvr/Ped Actn:				4	Obj Strk:						
Unit	2 : 2	Alchl/Drugs:	0	Speed:	50 MPH Dir: W	Veh Mnvr/Ped Actn:				11	Obj Strk:						
245	103279138	22.520	10/17/2011 12:20	FIXED OBJECT	\$ 15000	0	0	0	0	1	1	1	3	0	0		
Unit	1 : 1	Alchl/Drugs:	0	Speed:	75 MPH Dir: W	Veh Mnvr/Ped Actn:				4	Obj Strk:		59				

**North Carolina Department of Transportation
Traffic Engineering Accident Analysis System
Strip Analysis Report**

Acc No	Crash ID	Milepost	Date	Accident Type	Total Damage	Injuries				Condition			Road		Trfc Ctl	
						F	A	B	C	R	L	W	Ch	Ci	Dv	Op
246	103064102	22.550	01/10/2011 11:12	FIXED OBJECT	\$ 1000	0	0	0	0	5	1	4	3	0	0	
Unit	1 : 4	Alchl/Drugs:	0	Speed:	25 MPH Dir: E	Veh Mnvr/Ped Actn:				4	Obj Strk:		44			
247	102911207	22.610	06/29/2010 17:25	REAR END, SLOW OR STOP	\$ 4500	0	0	0	0	1	1	1	1	0	0	
Unit	1 : 1	Alchl/Drugs:	0	Speed:	60 MPH Dir: W	Veh Mnvr/Ped Actn:				4	Obj Strk:					
Unit	2 : 4	Alchl/Drugs:	0	Speed:	60 MPH Dir: W	Veh Mnvr/Ped Actn:				11	Obj Strk:					
248	103292632	22.610	11/03/2011 17:30	REAR END, SLOW OR STOP	\$ 3300	0	0	0	0	2	1	2	1	0	0	
Unit	1 : 1	Alchl/Drugs:	0	Speed:	50 MPH Dir: E	Veh Mnvr/Ped Actn:				4	Obj Strk:					
Unit	2 : 4	Alchl/Drugs:	0	Speed:	50 MPH Dir: E	Veh Mnvr/Ped Actn:				11	Obj Strk:					
249	103404494	22.610	03/18/2012 17:03	REAR END, SLOW OR STOP	\$ 10300	0	0	0	0	1	1	1	1	0	0	
Unit	1 : 1	Alchl/Drugs:	0	Speed:	60 MPH Dir: N	Veh Mnvr/Ped Actn:				4	Obj Strk:					
Unit	2 : 1	Alchl/Drugs:	0	Speed:	60 MPH Dir: N	Veh Mnvr/Ped Actn:				11	Obj Strk:					
Unit	3 : 1	Alchl/Drugs:	0	Speed:	60 MPH Dir: N	Veh Mnvr/Ped Actn:				11	Obj Strk:					
250	102878472	22.620	06/03/2010 17:35	REAR END, SLOW OR STOP	\$ 9500	0	0	0	1	1	1	1	1	0	0	
Unit	1 : 1	Alchl/Drugs:	0	Speed:	20 MPH Dir: S	Veh Mnvr/Ped Actn:				4	Obj Strk:					
Unit	2 : 4	Alchl/Drugs:	0	Speed:	20 MPH Dir: S	Veh Mnvr/Ped Actn:				11	Obj Strk:					
251	102897508	22.620	06/21/2010 17:44	REAR END, SLOW OR STOP	\$ 2200	0	0	0	0	1	1	1	5	0	0	
Unit	1 : 1	Alchl/Drugs:	0	Speed:	45 MPH Dir: E	Veh Mnvr/Ped Actn:				4	Obj Strk:					
Unit	2 : 1	Alchl/Drugs:	0	Speed:	40 MPH Dir: E	Veh Mnvr/Ped Actn:				11	Obj Strk:					
252	103114761	22.620	03/10/2011 08:45	OVERTURN/ROLLOVER	\$ 2000	0	0	0	1	2	1	2	3	0	0	
Unit	1 : 1	Alchl/Drugs:	0	Speed:	65 MPH Dir: N	Veh Mnvr/Ped Actn:				4	Obj Strk:		59			
253	103221151	22.620	08/07/2011 00:29	FIXED OBJECT	\$ 800	0	0	0	0	1	5	1	5	0	0	
Unit	1 : 1	Alchl/Drugs:	0	Speed:	60 MPH Dir: S	Veh Mnvr/Ped Actn:				4	Obj Strk:		44			
254	103226851	22.620	08/13/2011 14:20	REAR END, SLOW OR STOP	\$ 5000	0	0	0	0	2	1	3	3	0	0	
Unit	1 : 4	Alchl/Drugs:	0	Speed:	60 MPH Dir: W	Veh Mnvr/Ped Actn:				4	Obj Strk:					
Unit	2 : 1	Alchl/Drugs:	0	Speed:	40 MPH Dir: W	Veh Mnvr/Ped Actn:				11	Obj Strk:					
255	102906199	22.710	06/29/2010 17:26	REAR END, SLOW OR STOP	\$ 9000	0	0	0	1	1	1	1	1	0	0	
Unit	1 : 2	Alchl/Drugs:	0	Speed:	50 MPH Dir: W	Veh Mnvr/Ped Actn:				4	Obj Strk:					

**North Carolina Department of Transportation
Traffic Engineering Accident Analysis System
Strip Analysis Report**

Acc No	Crash ID	Milepost	Date	Accident Type	Total Damage	Injuries				Condition			Road		Trfc Ctl	
						F	A	B	C	R	L	W	Ch	Ci	Dv	Op
Unit	2 : 4	Alchl/Drgs:	0	Speed:	40 MPH	Dir:	W	Veh Mnvr/Ped Actn:				11	Obj Strk:			
256	102898085	22.720	06/23/2010 23:10	REAR END, SLOW OR STOP	\$ 3400	0	0	0	0	1	5	1	7	0	0	
Unit	1 : 1	Alchl/Drgs:	0	Speed:	45 MPH	Dir:	W	Veh Mnvr/Ped Actn:				4	Obj Strk:			
Unit	2 : 2	Alchl/Drgs:	0	Speed:	15 MPH	Dir:	W	Veh Mnvr/Ped Actn:				11	Obj Strk:			
257	103068183	22.820	01/17/2011 00:30	OVERTURN/ROLLOVER	\$ 6000	0	0	0	2	2	5	1	7	0	0	
Unit	1 : 1	Alchl/Drgs:	2	Speed:	60 MPH	Dir:	E	Veh Mnvr/Ped Actn:				4	Obj Strk: 59			
258	103187919	22.820	06/26/2011 21:45	FIXED OBJECT	\$ 8000	0	0	1	0	1	5	1	3	0	0	
Unit	1 : 1	Alchl/Drgs:	1	Speed:	50 MPH	Dir:	W	Veh Mnvr/Ped Actn:				4	Obj Strk: 59			
259	103464019	22.820	05/23/2012 06:20	FIXED OBJECT	\$ 15000	0	0	0	0	2	1	4	8	0	0	
Unit	1 : 14	Alchl/Drgs:	0	Speed:	65 MPH	Dir:	SE	Veh Mnvr/Ped Actn:				4	Obj Strk: 59			
260	103485257	22.820	06/28/2012 06:57	FIXED OBJECT	\$ 32000	0	0	0	0	1	1	1	7	0	0	
Unit	1 : 4	Alchl/Drgs:	0	Speed:	60 MPH	Dir:	W	Veh Mnvr/Ped Actn:				4	Obj Strk: 41			
261	102762410	22.920	12/17/2009 17:35	REAR END, SLOW OR STOP	\$ 1805	0	0	0	0	1	2	1	1	0	0	
Unit	1 : 1	Alchl/Drgs:	0	Speed:	60 MPH	Dir:	E	Veh Mnvr/Ped Actn:				4	Obj Strk:			
Unit	2 : 4	Alchl/Drgs:	0	Speed:	60 MPH	Dir:	E	Veh Mnvr/Ped Actn:				11	Obj Strk:			
Unit	3 : 2	Alchl/Drgs:	0	Speed:	0 MPH	Dir:	E	Veh Mnvr/Ped Actn:				1	Obj Strk:			
262	103222281	22.920	08/05/2011 17:31	REAR END, SLOW OR STOP	\$ 2200	0	0	0	0	1	1	1	1	0	0	
Unit	1 : 1	Alchl/Drgs:	0	Speed:	45 MPH	Dir:	W	Veh Mnvr/Ped Actn:				4	Obj Strk:			
Unit	2 : 4	Alchl/Drgs:	0	Speed:	35 MPH	Dir:	W	Veh Mnvr/Ped Actn:				4	Obj Strk:			
263	103236626	22.920	08/25/2011 08:30	RAN OFF ROAD - RIGHT	\$ 3500	0	0	0	0	1	1	1	3	0		
Unit	1 : 1	Alchl/Drgs:	0	Speed:	65 MPH	Dir:	W	Veh Mnvr/Ped Actn:				4	Obj Strk: 48			
264	103272011	22.920	10/06/2011 21:20	FIXED OBJECT	\$ 5500	0	0	0	0	1	5	1	1	0		
Unit	1 : 1	Alchl/Drgs:	0	Speed:	75 MPH	Dir:	W	Veh Mnvr/Ped Actn:				4	Obj Strk: 42			
265	103489285	22.920	07/03/2012 14:13	OVERTURN/ROLLOVER	\$ 10000	0	0	0	0	1	1	2	3	0	0	
Unit	1 : 11	Alchl/Drgs:	0	Speed:	60 MPH	Dir:	SE	Veh Mnvr/Ped Actn:				11	Obj Strk:			

**North Carolina Department of Transportation
Traffic Engineering Accident Analysis System
Strip Analysis Report**

Acc No	Crash ID	Milepost	Date	Accident Type	Total Damage	Injuries				Condition			Road		Trfc Ctl	
						F	A	B	C	R	L	W	Ch	Ci	Dv	Op
266	103481753	22.967	06/22/2012 14:05	REAR END, SLOW OR STOP	\$ 4000	0	0	0	0	1	1	2	3	0	0	
Unit	1 : 1	Alchl/Drugs:	0	Speed:	50 MPH Dir: W	Veh Mnvr/Ped Actn:				4	Obj Strk:					
Unit	2 : 4	Alchl/Drugs:	0	Speed:	50 MPH Dir: W	Veh Mnvr/Ped Actn:				11	Obj Strk:					
267	103156155	23.010	05/13/2011 15:26	FIXED OBJECT	\$ 1000	0	0	0	1	1	1	1	1	0	0	
Unit	1 : 1	Alchl/Drugs:	0	Speed:	60 MPH Dir: E	Veh Mnvr/Ped Actn:				4	Obj Strk: 59					
268	103404226	23.010	03/17/2012 02:08	FIXED OBJECT	\$ 11500	0	0	1	0	1	5	2	7	0	0	
Unit	1 : 5	Alchl/Drugs:	0	Speed:	75 MPH Dir: W	Veh Mnvr/Ped Actn:				4	Obj Strk: 41					
269	102865865	23.038	05/17/2010 12:42	FIXED OBJECT	\$ 1200	0	0	0	0	2	1	3	1	0	0	
Unit	1 : 2	Alchl/Drugs:	0	Speed:	60 MPH Dir: W	Veh Mnvr/Ped Actn:				4	Obj Strk: 42					
270	102899193	23.038	06/26/2010 15:15	REAR END, SLOW OR STOP	\$ 1000	0	0	0	0	1	1	1	7	0	0	
Unit	1 : 4	Alchl/Drugs:	0	Speed:	20 MPH Dir: N	Veh Mnvr/Ped Actn:				4	Obj Strk:					
Unit	2 : 1	Alchl/Drugs:	0	Speed:	20 MPH Dir: N	Veh Mnvr/Ped Actn:				1	Obj Strk:					
271	102659499	23.080	08/12/2009 10:19	REAR END, SLOW OR STOP	\$ 4000	0	0	0	0	2	1	2	1	0	0	
Unit	1 : 10	Alchl/Drugs:	0	Speed:	45 MPH Dir: E	Veh Mnvr/Ped Actn:				4	Obj Strk:					
Unit	2 : 2	Alchl/Drugs:	0	Speed:	45 MPH Dir: E	Veh Mnvr/Ped Actn:				11	Obj Strk:					
272	103328104	23.110	12/13/2011 04:18	FIXED OBJECT	\$ 5500	0	0	1	0	1	5	1	7	0	0	
Unit	1 : 1	Alchl/Drugs:	3	Speed:	70 MPH Dir: S	Veh Mnvr/Ped Actn:				4	Obj Strk: 58					
273	103139620	23.120	04/20/2011 10:54	JACKKNIFE	\$ 4500	0	0	0	0	2	1	3	7	0	0	
Unit	1 : 14	Alchl/Drugs:	0	Speed:	60 MPH Dir: E	Veh Mnvr/Ped Actn:				4	Obj Strk: 59					
274	102815969	23.138	03/15/2010 19:11	FIXED OBJECT	\$ 3000	0	0	0	0	1	2	2	7	0	0	
Unit	1 : 1	Alchl/Drugs:	0	Speed:	60 MPH Dir: N	Veh Mnvr/Ped Actn:				4	Obj Strk: 42					
275	103496504	23.170	07/11/2012 15:00	REAR END, SLOW OR STOP	\$ 1600	0	0	0	0	2	1	2	3	0	0	
Unit	1 : 2	Alchl/Drugs:	0	Speed:	35 MPH Dir: W	Veh Mnvr/Ped Actn:				4	Obj Strk:					
Unit	2 : 1	Alchl/Drugs:	0	Speed:	0 MPH Dir: W	Veh Mnvr/Ped Actn:				1	Obj Strk:					
276	102809406	23.210	03/02/2010 05:30	FIXED OBJECT	\$ 8000	0	0	0	0	2	5	4	7	0	0	
Unit	1 : 1	Alchl/Drugs:	0	Speed:	60 MPH Dir: E	Veh Mnvr/Ped Actn:				4	Obj Strk: 59					

**North Carolina Department of Transportation
Traffic Engineering Accident Analysis System
Strip Analysis Report**

Acc No	Crash ID	Milepost	Date	Accident Type	Total Damage	Injuries				Condition			Road		Trfc Ctl	
						F	A	B	C	R	L	W	Ch	Ci	Dv	Op
277	102943216	23.238	08/21/2010 15:13	REAR END, SLOW OR STOP	\$ 8000	0	0	0	0	2	1	2	7	0	0	
Unit	1 : 1	Alchl/Drgs:	0	Speed: 45 MPH Dir: W		Veh Mnvr/Ped Actn:				4	Obj Strk:					
Unit	2 : 1	Alchl/Drgs:	0	Speed: 45 MPH Dir: W		Veh Mnvr/Ped Actn:				11	Obj Strk:					
278	102960184	23.320	09/11/2010 07:25	SIDESWIPE, SAME DIRECTION	\$ 2000	0	0	0	0	2	1	3	3	0	0	
Unit	1 : 1	Alchl/Drgs:	0	Speed: 55 MPH Dir: E		Veh Mnvr/Ped Actn:				5	Obj Strk:		42			
Unit	2 : 2	Alchl/Drgs:	0	Speed: 60 MPH Dir: E		Veh Mnvr/Ped Actn:				4	Obj Strk:					
279	103051194	23.320	12/25/2010 09:00	FIXED OBJECT	\$ 1500	0	0	0	0	5	1	4	3	0	0	
Unit	1 : 1	Alchl/Drgs:	0	Speed: 55 MPH Dir: E		Veh Mnvr/Ped Actn:				4	Obj Strk:		59			
280	103428769	23.320	04/18/2012 10:10	RAN OFF ROAD - LEFT	\$ 3000	0	0	0	0	2	1	3	3	0	0	
Unit	1 : 4	Alchl/Drgs:	0	Speed: 55 MPH Dir: W		Veh Mnvr/Ped Actn:				4	Obj Strk:		59			
281	102951806	23.338	08/31/2010 14:24	REAR END, SLOW OR STOP	\$ 2750	0	0	0	0	1	1	1	1	0	0	
Unit	1 : 4	Alchl/Drgs:	0	Speed: 60 MPH Dir: E		Veh Mnvr/Ped Actn:				4	Obj Strk:					
Unit	2 : 1	Alchl/Drgs:	0	Speed: 60 MPH Dir: E		Veh Mnvr/Ped Actn:				11	Obj Strk:					
282	102742228	23.420	12/12/2009 13:06	REAR END, SLOW OR STOP	\$ 5000	0	0	0	0	1	1	2	1	0	0	
Unit	1 : 4	Alchl/Drgs:	0	Speed: 65 MPH Dir: N		Veh Mnvr/Ped Actn:				4	Obj Strk:					
Unit	2 : 1	Alchl/Drgs:	0	Speed: 60 MPH Dir: N		Veh Mnvr/Ped Actn:				4	Obj Strk:					
283	102918976	23.420	07/21/2010 14:55	FIXED OBJECT	\$ 1500	0	0	0	1	2	1	3	3	0	0	
Unit	1 : 2	Alchl/Drgs:	0	Speed: 55 MPH Dir: W		Veh Mnvr/Ped Actn:				4	Obj Strk:		42			
284	102925940	23.420	07/31/2010 18:39	REAR END, SLOW OR STOP	\$ 4500	0	0	0	1	1	1	2	3	0	0	
Unit	1 : 1	Alchl/Drgs:	0	Speed: 60 MPH Dir: W		Veh Mnvr/Ped Actn:				4	Obj Strk:					
Unit	2 : 1	Alchl/Drgs:	0	Speed: 45 MPH Dir: W		Veh Mnvr/Ped Actn:				4	Obj Strk:					
Unit	3 : 1	Alchl/Drgs:	0	Speed: 20 MPH Dir: W		Veh Mnvr/Ped Actn:				4	Obj Strk:					
Unit	4 : 4	Alchl/Drgs:	0	Speed: 10 MPH Dir: W		Veh Mnvr/Ped Actn:				4	Obj Strk:					
285	102959761	23.420	08/30/2010 08:15	OTHER NON-COLLISION	\$ 1000	0	0	0	0	1	1	1	3	0	0	1
Unit	1 : 1	Alchl/Drgs:	0	Speed: 50 MPH Dir: W		Veh Mnvr/Ped Actn:				4	Obj Strk:					
Unit	2 : 10	Alchl/Drgs:	7	Speed: 60 MPH Dir: W		Veh Mnvr/Ped Actn:				4	Obj Strk:					
286	103032991	23.420	08/30/2010 08:21	MOVABLE OBJECT	\$ 1966	0	0	0	0	1	1	1	2	0	0	
Unit	1 : 4	Alchl/Drgs:	0	Speed: 60 MPH Dir: W		Veh Mnvr/Ped Actn:				4	Obj Strk:		18			

**North Carolina Department of Transportation
Traffic Engineering Accident Analysis System
Strip Analysis Report**

Acc No	Crash ID	Milepost	Date	Accident Type	Total Damage	Injuries				Condition			Road		Trfc Ctl	
						F	A	B	C	R	L	W	Ch	Ci	Dv	Op
287	102980989	23.420	10/05/2010 17:49	SIDESWIPE, SAME DIRECTION	\$ 1000	0	0	0	0	1	1	1	1	0	0	
Unit	1 : 1	Alchl/Drgs:	0	Speed: 60 MPH Dir: E		Veh Mnvr/Ped Actn:				4	Obj Strk:					
Unit	2 : 1	Alchl/Drgs:	0	Speed: 60 MPH Dir: E		Veh Mnvr/Ped Actn:				4	Obj Strk:					
288	103123359	23.420	03/26/2011 21:49	FIXED OBJECT	\$ 1000	0	0	0	1	2	5	3	3	0	0	
Unit	1 : 2	Alchl/Drgs:	0	Speed: 60 MPH Dir: W		Veh Mnvr/Ped Actn:				4	Obj Strk:		46			
289	103464546	23.420	05/03/2012 14:30	SIDESWIPE, SAME DIRECTION	\$ 4000	0	0	0	0	1	1	2	3	0	0	
Unit	1 : 4	Alchl/Drgs:	7	Speed: 65 MPH Dir: W		Veh Mnvr/Ped Actn:				5	Obj Strk:					
Unit	2 : 1	Alchl/Drgs:	0	Speed: 60 MPH Dir: W		Veh Mnvr/Ped Actn:				4	Obj Strk:					
290	103200065	23.438	07/05/2011 18:25	FIXED OBJECT	\$ 11800	0	0	0	0	1	1	1	7	0	0	
Unit	1 : 4	Alchl/Drgs:	0	Speed: 65 MPH Dir: W		Veh Mnvr/Ped Actn:				5	Obj Strk:		42			
291	103080273	23.510	01/31/2011 07:25	REAR END, SLOW OR STOP	\$ 2000	0	0	0	0	1	1	1	1	0	0	
Unit	1 : 1	Alchl/Drgs:	0	Speed: 50 MPH Dir: E		Veh Mnvr/Ped Actn:				4	Obj Strk:					
Unit	2 : 1	Alchl/Drgs:	0	Speed: 60 MPH Dir: E		Veh Mnvr/Ped Actn:				11	Obj Strk:					
Unit	3 : 1	Alchl/Drgs:	0	Speed: 55 MPH Dir: E		Veh Mnvr/Ped Actn:				11	Obj Strk:					
292	103499847	23.510	06/21/2012 15:31	RAN OFF ROAD - LEFT	\$ 5500	0	0	0	0	3	1	3	1	0		
Unit	1 : 1	Alchl/Drgs:	0	Speed: 60 MPH Dir: S		Veh Mnvr/Ped Actn:				5	Obj Strk:					
Unit	2 : 5	Alchl/Drgs:	0	Speed: 60 MPH Dir: S		Veh Mnvr/Ped Actn:				4	Obj Strk:		44			
293	103151532	23.520	05/07/2011 10:33	SIDESWIPE, SAME DIRECTION	\$ 2200	0	0	0	0	1	1	1	3	0	0	
Unit	1 : 1	Alchl/Drgs:	0	Speed: 65 MPH Dir: E		Veh Mnvr/Ped Actn:				5	Obj Strk:					
Unit	2 : 11	Alchl/Drgs:	0	Speed: 60 MPH Dir: E		Veh Mnvr/Ped Actn:				4	Obj Strk:					
294	103079446	23.620	01/31/2011 06:20	REAR END, SLOW OR STOP	\$ 30250	0	0	1	0	1	5	1	6	0	0	
Unit	1 : 14	Alchl/Drgs:	0	Speed: 55 MPH Dir: S		Veh Mnvr/Ped Actn:				4	Obj Strk:					
Unit	2 : 2	Alchl/Drgs:	0	Speed: 75 MPH Dir: S		Veh Mnvr/Ped Actn:				4	Obj Strk:		37			
295	103174666	23.620	06/07/2011 15:40	REAR END, SLOW OR STOP	\$ 2000	0	0	0	0	1	1	1	3	0	0	
Unit	1 : 5	Alchl/Drgs:	0	Speed: 60 MPH Dir: E		Veh Mnvr/Ped Actn:				4	Obj Strk:					
Unit	2 : 1	Alchl/Drgs:	0	Speed: 60 MPH Dir: E		Veh Mnvr/Ped Actn:				11	Obj Strk:					

**North Carolina Department of Transportation
Traffic Engineering Accident Analysis System
Strip Analysis Report**

Acc No	Crash ID	Milepost	Date	Accident Type	Total Damage	Injuries				Condition			Road		Trfc Ctl	
						F	A	B	C	R	L	W	Ch	Ci	Dv	Op
296	103231790	23.620	08/19/2011 19:00	REAR END, SLOW OR STOP	\$ 3300	0	0	0	0	1	1	1	3	0	0	
Unit	1 : 4	Alchl/Drgs:	0	Speed: 60 MPH Dir: W		Veh Mnvr/Ped Actn:				4	Obj Strk:					
Unit	2 : 4	Alchl/Drgs:	0	Speed: 0 MPH Dir: W		Veh Mnvr/Ped Actn:				11	Obj Strk:					

297	103156892	23.638	05/15/2011 19:16	FIXED OBJECT	\$ 6000	0	0	1	2	1	1	1	5	0	0	
Unit	1 : 1	Alchl/Drgs:	0	Speed: 60 MPH Dir: W		Veh Mnvr/Ped Actn:				4	Obj Strk:		59			

298	102898297	23.670	06/25/2010 17:40	REAR END, SLOW OR STOP	\$ 1500	0	0	0	0	1	1	2	1	0	0	
Unit	1 : 2	Alchl/Drgs:	0	Speed: 50 MPH Dir: E		Veh Mnvr/Ped Actn:				11	Obj Strk:					
Unit	2 : 2	Alchl/Drgs:	0	Speed: 50 MPH Dir: E		Veh Mnvr/Ped Actn:				11	Obj Strk:					
Unit	3 : 1	Alchl/Drgs:	0	Speed: 50 MPH Dir: E		Veh Mnvr/Ped Actn:				4	Obj Strk:					

299	103171195	23.670	06/03/2011 09:30	REAR END, SLOW OR STOP	\$ 1600	0	0	0	0	1	1	1	1	0	0	
Unit	1 : 2	Alchl/Drgs:	0	Speed: 60 MPH Dir: W		Veh Mnvr/Ped Actn:				4	Obj Strk:					
Unit	2 : 1	Alchl/Drgs:	0	Speed: 60 MPH Dir: W		Veh Mnvr/Ped Actn:				11	Obj Strk:					

300	102683917	23.820	09/12/2009 13:38	REAR END, SLOW OR STOP	\$ 4500	0	0	1	0	1	1	1	3	0		
Unit	1 : 4	Alchl/Drgs:	0	Speed: 45 MPH Dir: N		Veh Mnvr/Ped Actn:				4	Obj Strk:					
Unit	2 : 2	Alchl/Drgs:	0	Speed: 45 MPH Dir: N		Veh Mnvr/Ped Actn:				4	Obj Strk:					
Unit	3 : 2	Alchl/Drgs:	0	Speed: 45 MPH Dir: N		Veh Mnvr/Ped Actn:				11	Obj Strk:					

301	102851546	23.820	04/25/2010 14:20	OVERTURN/ROLLOVER	\$ 3700	0	0	1	1	1	1	1	1	0	0	
Unit	1 : 20	Alchl/Drgs:	0	Speed: 25 MPH Dir: SE		Veh Mnvr/Ped Actn:				11	Obj Strk:					
Unit	2 : 1	Alchl/Drgs:	0	Speed: 0 MPH Dir: SE		Veh Mnvr/Ped Actn:				1	Obj Strk:					

302	103299391	23.820	11/10/2011 15:49	SIDESWIPE, SAME DIRECTION	\$ 1600	0	0	0	0	1	1	1	7	0	0	
Unit	1 : 4	Alchl/Drgs:	0	Speed: 65 MPH Dir: NW		Veh Mnvr/Ped Actn:				5	Obj Strk:					
Unit	2 : 4	Alchl/Drgs:	0	Speed: 60 MPH Dir: NW		Veh Mnvr/Ped Actn:				4	Obj Strk:					

303	102993345	23.880	10/23/2010 05:20	ANIMAL	\$ 3500	0	0	0	0	1	5	1	3	0	0	
Unit	1 : 1	Alchl/Drgs:	0	Speed: 60 MPH Dir: E		Veh Mnvr/Ped Actn:				4	Obj Strk:		17			

304	103000907	23.909	10/31/2010 13:41	REAR END, SLOW OR STOP	\$ 2000	0	0	0	3	1	1	1	1	4	0	
Unit	1 : 1	Alchl/Drgs:	0	Speed: 25 MPH Dir: E		Veh Mnvr/Ped Actn:				4	Obj Strk:					
Unit	2 : 4	Alchl/Drgs:	0	Speed: 10 MPH Dir: E		Veh Mnvr/Ped Actn:				11	Obj Strk:					

**North Carolina Department of Transportation
Traffic Engineering Accident Analysis System
Strip Analysis Report**

Acc No	Crash ID	Milepost	Date	Accident Type	Total Damage	Injuries				Condition			Road		Trfc Ctl	
						F	A	B	C	R	L	W	Ch	Ci	Dv	Op
305	102740520	23.920	11/20/2009 17:32	REAR END, SLOW OR STOP	\$ 1000	0	0	0	0	1	2	1	3	0	0	
Unit	1 : 2	Alchl/Drgs:	0	Speed: 55 MPH Dir: E		Veh Mnvr/Ped Actn: 4				Obj Strk:						
Unit	2 : 4	Alchl/Drgs:	0	Speed: 55 MPH Dir: E		Veh Mnvr/Ped Actn: 1				Obj Strk:						
306	102792368	23.920	02/11/2010 18:13	REAR END, SLOW OR STOP	\$ 3500	0	0	0	0	1	1	1	1	0	0	
Unit	1 : 2	Alchl/Drgs:	0	Speed: 45 MPH Dir: E		Veh Mnvr/Ped Actn: 4				Obj Strk:						
Unit	2 : 1	Alchl/Drgs:	0	Speed: 35 MPH Dir: E		Veh Mnvr/Ped Actn: 4				Obj Strk:						
307	102851599	23.920	04/25/2010 15:27	REAR END, SLOW OR STOP	\$ 4000	0	0	0	4	1	1	1	1	0	0	
Unit	1 : 4	Alchl/Drgs:	0	Speed: 35 MPH Dir: SE		Veh Mnvr/Ped Actn: 4				Obj Strk:						
Unit	2 : 3	Alchl/Drgs:	0	Speed: 0 MPH Dir: SE		Veh Mnvr/Ped Actn: 1				Obj Strk:						
308	102951043	23.920	08/28/2010 19:21	OVERTURN/ROLLOVER	\$ 1500	0	0	2	0	1	1	1	3	0	0	
Unit	1 : 20	Alchl/Drgs:	0	Speed: 30 MPH Dir: E		Veh Mnvr/Ped Actn: 4				Obj Strk:						
309	102961546	23.920	08/28/2010 21:30	REAR END, SLOW OR STOP	\$ 1300	0	0	0	0	1	1	1	3	0	2	
Unit	1 : 4	Alchl/Drgs:	0	Speed: 15 MPH Dir: E		Veh Mnvr/Ped Actn: 11				Obj Strk:						
Unit	2 : 1	Alchl/Drgs:	7	Speed: 25 MPH Dir: E		Veh Mnvr/Ped Actn: 4				Obj Strk:						
310	103031472	23.920	12/03/2010 11:10	REAR END, SLOW OR STOP	\$ 3500	0	0	0	0	1	1	1	3	0	0	
Unit	1 : 1	Alchl/Drgs:	0	Speed: 60 MPH Dir: E		Veh Mnvr/Ped Actn: 11				Obj Strk:						
Unit	2 : 2	Alchl/Drgs:	0	Speed: 60 MPH Dir: E		Veh Mnvr/Ped Actn: 4				Obj Strk:						
311	103046230	23.920	12/19/2010 18:31	OVERTURN/ROLLOVER	\$ 7500	0	0	0	1	1	5	1	7	0	0	
Unit	1 : 1	Alchl/Drgs:	0	Speed: 50 MPH Dir: S		Veh Mnvr/Ped Actn: 4				Obj Strk:						
312	103180406	23.920	06/17/2011 08:15	REAR END, SLOW OR STOP	\$ 1050	0	0	0	0	1	1	1	1	0	0	
Unit	1 : 1	Alchl/Drgs:	0	Speed: 35 MPH Dir: W		Veh Mnvr/Ped Actn: 4				Obj Strk:						
Unit	2 : 1	Alchl/Drgs:	0	Speed: 25 MPH Dir: W		Veh Mnvr/Ped Actn: 11				Obj Strk:						
313	103190811	23.920	07/01/2011 16:20	SIDESWIPE, SAME DIRECTION	\$ 5100	0	0	1	1	1	1	1	3	0	0	
Unit	1 : 12	Alchl/Drgs:	7	Speed: 60 MPH Dir: E		Veh Mnvr/Ped Actn: 4				Obj Strk:						
Unit	2 : 1	Alchl/Drgs:	0	Speed: 60 MPH Dir: E		Veh Mnvr/Ped Actn: 4				Obj Strk:						
314	103384298	23.920	02/19/2012 12:34	RAN OFF ROAD - LEFT	\$ 1700	0	0	0	0	2	1	3	3	0	0	
Unit	1 : 1	Alchl/Drgs:	0	Speed: 60 MPH Dir: S		Veh Mnvr/Ped Actn: 4				Obj Strk:		46				

**North Carolina Department of Transportation
Traffic Engineering Accident Analysis System
Strip Analysis Report**

Acc No	Crash ID	Milepost	Date	Accident Type	Total Damage	Injuries				Condition			Road		Trfc Ctl	
						F	A	B	C	R	L	W	Ch	Ci	Dv	Op
315	103407371	23.920	03/21/2012 07:19	SIDESWIPE, SAME DIRECTION	\$ 1200	0	0	0	0	1	3	1	3	0	0	
Unit	1 : 14	Alchl/Drgs:	7	Speed:	60 MPH Dir: W	Veh Mnvr/Ped Actn:				5	Obj Strk:					
Unit	2 : 1	Alchl/Drgs:	0	Speed:	60 MPH Dir: W	Veh Mnvr/Ped Actn:				4	Obj Strk:					
316	103051278	23.938	12/25/2010 14:12	SIDESWIPE, SAME DIRECTION	\$ 16500	0	0	0	0	5	1	4	3	1	0	
Unit	1 : 4	Alchl/Drgs:	0	Speed:	45 MPH Dir: W	Veh Mnvr/Ped Actn:				4	Obj Strk: 59					
Unit	2 : 2	Alchl/Drgs:	0	Speed:	40 MPH Dir: W	Veh Mnvr/Ped Actn:				4	Obj Strk:					
317	103231953	23.938	08/20/2011 03:01	REAR END, SLOW OR STOP	\$ 12000	0	0	1	0	1	5	1	1	0	0	
Unit	1 : 1	Alchl/Drgs:	0	Speed:	75 MPH Dir: E	Veh Mnvr/Ped Actn:				4	Obj Strk:					
Unit	2 : 1	Alchl/Drgs:	0	Speed:	65 MPH Dir: E	Veh Mnvr/Ped Actn:				4	Obj Strk: 44					
318	103182380	23.980	06/17/2011 07:20	SIDESWIPE, SAME DIRECTION	\$ 6800	0	0	0	1	1	1	1	3	0	0	
Unit	1 : 14	Alchl/Drgs:	0	Speed:	45 MPH Dir: W	Veh Mnvr/Ped Actn:				5	Obj Strk:					
Unit	2 : 1	Alchl/Drgs:	0	Speed:	60 MPH Dir: W	Veh Mnvr/Ped Actn:				4	Obj Strk: 42					
319	102825431	24.020	03/25/2010 08:27	FIXED OBJECT	\$ 13600	0	0	0	1	1	1	2	3	0	0	
Unit	1 : 1	Alchl/Drgs:	0	Speed:	60 MPH Dir: E	Veh Mnvr/Ped Actn:				4	Obj Strk: 44					
320	102980598	24.020	10/08/2010 15:16	REAR END, SLOW OR STOP	\$ 1100	0	0	0	0	1	1	1	1	0	0	
Unit	1 : 1	Alchl/Drgs:	0	Speed:	50 MPH Dir: E	Veh Mnvr/Ped Actn:				4	Obj Strk:					
Unit	2 : 1	Alchl/Drgs:	0	Speed:	15 MPH Dir: E	Veh Mnvr/Ped Actn:				4	Obj Strk:					
321	103028436	24.020	12/01/2010 12:00	MOVABLE OBJECT	\$ 1800	0	0	0	0	1	1	2	1	0	0	
Unit	1 : 1	Alchl/Drgs:	0	Speed:	60 MPH Dir: E	Veh Mnvr/Ped Actn:				4	Obj Strk: 18					
322	103415204	24.020	03/30/2012 17:05	REAR END, SLOW OR STOP	\$ 350	0	0	0	0	2	1	2	3	0	0	
Unit	1 : 1	Alchl/Drgs:	0	Speed:	15 MPH Dir: N	Veh Mnvr/Ped Actn:				4	Obj Strk:					
Unit	2 : 1	Alchl/Drgs:	0	Speed:	10 MPH Dir: N	Veh Mnvr/Ped Actn:				11	Obj Strk:					
323	103456417	24.020	05/22/2012 13:45	FIXED OBJECT	\$ 40800	0	0	0	1	1	1	1	3	0	0	
Unit	1 : 10	Alchl/Drgs:	0	Speed:	60 MPH Dir: N	Veh Mnvr/Ped Actn:				4	Obj Strk: 44					
324	102986976	24.038	10/15/2010 17:58	REAR END, SLOW OR STOP	\$ 1600	0	0	0	0	1	1	1	3	0	0	
Unit	1 : 1	Alchl/Drgs:	0	Speed:	45 MPH Dir: W	Veh Mnvr/Ped Actn:				4	Obj Strk:					
Unit	2 : 1	Alchl/Drgs:	0	Speed:	45 MPH Dir: W	Veh Mnvr/Ped Actn:				11	Obj Strk:					

**North Carolina Department of Transportation
Traffic Engineering Accident Analysis System
Strip Analysis Report**

Acc No	Crash ID	Milepost	Date	Accident Type	Total Damage	Injuries				Condition			Road		Trfc Ctl	
						F	A	B	C	R	L	W	Ch	Ci	Dv	Op
325	103497085	24.050	07/13/2012 19:33	RAN OFF ROAD - LEFT	\$ 2500	0	0	0	0	2	1	3	3	0	0	
Unit	1 : 1	Alchl/Drgs:	0	Speed: 60 MPH Dir: E		Veh Mnvr/Ped Actn: 4				Obj Strk: 44						
326	103203655	24.061	07/17/2011 10:55	SIDESWIPE, SAME DIRECTION	\$ 9000	0	0	0	1	1	1	2	3	0	0	
Unit	1 : 1	Alchl/Drgs:	7	Speed: 70 MPH Dir: E		Veh Mnvr/Ped Actn: 5				Obj Strk:						
Unit	2 : 1	Alchl/Drgs:	0	Speed: 60 MPH Dir: E		Veh Mnvr/Ped Actn: 4				Obj Strk: 42						
327	102758575	24.080	12/08/2009 17:53	REAR END, SLOW OR STOP	\$ 1400	0	0	0	1	2	5	2	3	0	3	1
Unit	1 : 1	Alchl/Drgs:	0	Speed: 35 MPH Dir: NW		Veh Mnvr/Ped Actn: 4				Obj Strk:						
Unit	2 : 1	Alchl/Drgs:	0	Speed: 35 MPH Dir: NW		Veh Mnvr/Ped Actn: 11				Obj Strk:						
328	103170591	24.120	06/04/2011 14:11	SIDESWIPE, SAME DIRECTION	\$ 500	0	0	0	0	1	1	1	1	0	0	
Unit	1 : 4	Alchl/Drgs:	0	Speed: 65 MPH Dir: E		Veh Mnvr/Ped Actn: 4				Obj Strk:						
Unit	2 : 1	Alchl/Drgs:	7	Speed: 65 MPH Dir: E		Veh Mnvr/Ped Actn: 4				Obj Strk:						
329	103310725	24.120	11/23/2011 14:59	SIDESWIPE, SAME DIRECTION	\$ 5500	0	0	0	1	1	1	2	3	0	0	
Unit	1 : 4	Alchl/Drgs:	0	Speed: 50 MPH Dir: NW		Veh Mnvr/Ped Actn: 16				Obj Strk: 44						
Unit	2 : 1	Alchl/Drgs:	0	Speed: 45 MPH Dir: NW		Veh Mnvr/Ped Actn: 4				Obj Strk:						
330	102802559	24.138	02/10/2010 13:32	SIDESWIPE, SAME DIRECTION	\$ 1500	0	0	0	0	1	1	1	1	0	0	1
Unit	1 : 1	Alchl/Drgs:	0	Speed: 60 MPH Dir: S		Veh Mnvr/Ped Actn: 4				Obj Strk:						
Unit	2 : 1	Alchl/Drgs:	0	Speed: 55 MPH Dir: S		Veh Mnvr/Ped Actn: 4				Obj Strk:						
331	102884421	24.138	06/10/2010 17:58	REAR END, SLOW OR STOP	\$ 5000	0	0	0	0	1	1	1	3	0	0	
Unit	1 : 4	Alchl/Drgs:	0	Speed: 40 MPH Dir: W		Veh Mnvr/Ped Actn: 11				Obj Strk:						
Unit	2 : 1	Alchl/Drgs:	0	Speed: 40 MPH Dir: W		Veh Mnvr/Ped Actn: 4				Obj Strk:						
332	103018878	24.138	11/19/2010 15:56	MOVABLE OBJECT	\$ 2100	0	0	0	2	1	1	1	3	0	0	
Unit	1 : 2	Alchl/Drgs:	0	Speed: 60 MPH Dir: E		Veh Mnvr/Ped Actn: 4				Obj Strk:						
Unit	2 : 1	Alchl/Drgs:	0	Speed: 60 MPH Dir: E		Veh Mnvr/Ped Actn: 4				Obj Strk: 18						
Unit	3 : 4	Alchl/Drgs:	0	Speed: 60 MPH Dir: E		Veh Mnvr/Ped Actn: 4				Obj Strk: 59						
333	103027650	24.138	11/30/2010 17:50	SIDESWIPE, SAME DIRECTION	\$ 1500	0	0	0	0	2	5	3	3	0	0	
Unit	1 : 14	Alchl/Drgs:	0	Speed: 50 MPH Dir: W		Veh Mnvr/Ped Actn: 5				Obj Strk:						
Unit	2 : 1	Alchl/Drgs:	0	Speed: 50 MPH Dir: W		Veh Mnvr/Ped Actn: 4				Obj Strk:						

**North Carolina Department of Transportation
Traffic Engineering Accident Analysis System
Strip Analysis Report**

Acc No	Crash ID	Milepost	Date	Accident Type	Total Damage	Injuries				Condition			Road		Trfc Ctl	
						F	A	B	C	R	L	W	Ch	Ci	Dv	Op
334	103057232	24.138	12/25/2010 17:05	FIXED OBJECT	\$ 3000	0	0	0	0	4	5	4	2	0	0	
Unit	1 : 1	Alchl/Drgs:	0	Speed:	40 MPH	Dir:	W	Veh Mnvr/Ped Actn:				4	Obj Strk:		48	
335	103171617	24.138	06/06/2011 17:27	REAR END, SLOW OR STOP	\$ 2500	0	0	0	1	1	1	2	3	0	0	
Unit	1 : 2	Alchl/Drgs:	0	Speed:	45 MPH	Dir:	E	Veh Mnvr/Ped Actn:				4	Obj Strk:			
Unit	2 : 4	Alchl/Drgs:	0	Speed:	45 MPH	Dir:	E	Veh Mnvr/Ped Actn:				11	Obj Strk:			
Unit	3 : 1	Alchl/Drgs:	0	Speed:	45 MPH	Dir:	E	Veh Mnvr/Ped Actn:				1	Obj Strk:			
336	103309938	24.180	11/22/2011 19:11	RAN OFF ROAD - RIGHT	\$ 5000	0	0	0	0	2	5	3	3	0	0	
Unit	1 : 4	Alchl/Drgs:	0	Speed:	65 MPH	Dir:	W	Veh Mnvr/Ped Actn:				4	Obj Strk:		59	
337	102773486	24.220	01/24/2010 17:05	REAR END, SLOW OR STOP	\$ 2900	0	0	0	1	2	1	2	3	0	0	
Unit	1 : 1	Alchl/Drgs:	0	Speed:	55 MPH	Dir:	E	Veh Mnvr/Ped Actn:				4	Obj Strk:			
Unit	2 : 3	Alchl/Drgs:	0	Speed:	55 MPH	Dir:	E	Veh Mnvr/Ped Actn:				1	Obj Strk:			
338	102980594	24.220	10/08/2010 15:22	REAR END, SLOW OR STOP	\$ 9000	0	0	0	1	1	1	1	1	0	0	
Unit	1 : 4	Alchl/Drgs:	0	Speed:	55 MPH	Dir:	W	Veh Mnvr/Ped Actn:				4	Obj Strk:			
Unit	2 : 2	Alchl/Drgs:	0	Speed:	0 MPH	Dir:	W	Veh Mnvr/Ped Actn:				4	Obj Strk:			
Unit	3 : 1	Alchl/Drgs:	0	Speed:	0 MPH	Dir:	W	Veh Mnvr/Ped Actn:				4	Obj Strk:			
339	103107924	24.220	03/09/2011 12:55	FIXED OBJECT	\$ 6000	0	0	0	1	3	1	3	3	0	0	
Unit	1 : 1	Alchl/Drgs:	0	Speed:	60 MPH	Dir:	S	Veh Mnvr/Ped Actn:				4	Obj Strk:		44	
340	103486600	24.220	06/29/2012 16:38	REAR END, SLOW OR STOP	\$ 1300	0	0	0	0	1	1	1	1	0	0	
Unit	1 : 4	Alchl/Drgs:	0	Speed:	60 MPH	Dir:	N	Veh Mnvr/Ped Actn:				4	Obj Strk:			
Unit	2 : 5	Alchl/Drgs:	0	Speed:	60 MPH	Dir:	N	Veh Mnvr/Ped Actn:				1	Obj Strk:			
Unit	3 : 1	Alchl/Drgs:	0	Speed:	60 MPH	Dir:	N	Veh Mnvr/Ped Actn:				1	Obj Strk:			
341	102768315	24.250	01/12/2010 10:42	FIXED OBJECT	\$ 2000	0	0	0	0	4	1	2	3	0	0	
Unit	1 : 4	Alchl/Drgs:	0	Speed:	20 MPH	Dir:	W	Veh Mnvr/Ped Actn:				4	Obj Strk:		42	
342	103497278	24.260	07/14/2012 17:11	REAR END, SLOW OR STOP	\$ 1500	0	0	0	0	1	1	2	5	0	0	
Unit	1 : 1	Alchl/Drgs:	0	Speed:	65 MPH	Dir:	W	Veh Mnvr/Ped Actn:				4	Obj Strk:			
Unit	2 : 4	Alchl/Drgs:	0	Speed:	65 MPH	Dir:	W	Veh Mnvr/Ped Actn:				11	Obj Strk:			
343	103508468	24.300	07/29/2012 17:06	SIDESWIPE, SAME DIRECTION	\$ 10000	0	0	0	0	1	1	1	3	0	0	
Unit	1 : 4	Alchl/Drgs:	0	Speed:	60 MPH	Dir:	N	Veh Mnvr/Ped Actn:				4	Obj Strk:		44	

**North Carolina Department of Transportation
Traffic Engineering Accident Analysis System
Strip Analysis Report**

Acc No	Crash ID	Milepost	Date	Accident Type	Total Damage	Injuries				Condition			Road		Trfc Ctl	
						F	A	B	C	R	L	W	Ch	Ci	Dv	Op
Unit	2 : 1	Alchl/Drgs:	0	Speed:	0 MPH	Dir:	N	Veh Mnvr/Ped Actn:				1	Obj Strk:		44	
344	102710172	24.320	10/29/2009 11:00	SIDESWIPE, SAME DIRECTION	\$ 2500	0	0	0	0	1	1	1	7	0	0	
Unit	1 : 4	Alchl/Drgs:	0	Speed:	55 MPH	Dir:	W	Veh Mnvr/Ped Actn:				4	Obj Strk:			
Unit	2 : 1	Alchl/Drgs:	0	Speed:	60 MPH	Dir:	W	Veh Mnvr/Ped Actn:				5	Obj Strk:			
345	102739886	24.320	12/08/2009 20:30	OVERTURN/ROLLOVER	\$ 8000	0	0	0	1	2	5	2	1	0	0	
Unit	1 : 4	Alchl/Drgs:	0	Speed:	55 MPH	Dir:	W	Veh Mnvr/Ped Actn:				4	Obj Strk:			
346	102887830	24.320	06/12/2010 12:20	SIDESWIPE, SAME DIRECTION	\$ 4500	0	0	0	0	1	1	1	1	0	0	
Unit	1 : 2	Alchl/Drgs:	0	Speed:	55 MPH	Dir:	S	Veh Mnvr/Ped Actn:				4	Obj Strk:			
Unit	2 : 4	Alchl/Drgs:	0	Speed:	50 MPH	Dir:	S	Veh Mnvr/Ped Actn:				5	Obj Strk:			
347	103030944	24.320	11/30/2010 06:45	SIDESWIPE, SAME DIRECTION	\$ 11200	0	0	0	1	2	5	3	3	0	0	
Unit	1 : 14	Alchl/Drgs:	0	Speed:	55 MPH	Dir:	SE	Veh Mnvr/Ped Actn:				4	Obj Strk:			
Unit	2 : 2	Alchl/Drgs:	0	Speed:	55 MPH	Dir:	SE	Veh Mnvr/Ped Actn:				4	Obj Strk:			
348	103073837	24.320	01/18/2011 00:50	FIXED OBJECT	\$ 1900	0	0	1	0	1	5	1	7	0	0	
Unit	1 : 2	Alchl/Drgs:	1	Speed:	75 MPH	Dir:	E	Veh Mnvr/Ped Actn:				4	Obj Strk:		44	
349	103176293	24.320	06/12/2011 14:25	RAN OFF ROAD - LEFT	\$ 12000	0	0	0	0	2	1	3	3	0	0	
Unit	1 : 1	Alchl/Drgs:	0	Speed:	50 MPH	Dir:	E	Veh Mnvr/Ped Actn:				4	Obj Strk:		42	
350	103351140	24.320	01/11/2012 16:34	FIXED OBJECT	\$ 1100	0	0	0	0	2	1	2	5	0	0	
Unit	1 : 1	Alchl/Drgs:	0	Speed:	60 MPH	Dir:	S	Veh Mnvr/Ped Actn:				4	Obj Strk:		44	
351	103379527	24.320	02/13/2012 01:10	FIXED OBJECT	\$ 4200	0	0	0	1	1	5	1	7	0	0	
Unit	1 : 1	Alchl/Drgs:	0	Speed:	70 MPH	Dir:	E	Veh Mnvr/Ped Actn:				4	Obj Strk:		44	
352	103416736	24.320	04/01/2012 03:06	SIDESWIPE, SAME DIRECTION	\$ 4700	0	0	0	0	1	5	2	1	0	0	
Unit	1 : 4	Alchl/Drgs:	0	Speed:	60 MPH	Dir:	E	Veh Mnvr/Ped Actn:				4	Obj Strk:			
Unit	2 : 1	Alchl/Drgs:	0	Speed:	60 MPH	Dir:	E	Veh Mnvr/Ped Actn:				4	Obj Strk:			
353	102908715	24.338	07/10/2010 15:30	REAR END, SLOW OR STOP	\$ 3100	0	0	0	0	1	1	1	1	0	0	
Unit	1 : 4	Alchl/Drgs:	0	Speed:	45 MPH	Dir:	W	Veh Mnvr/Ped Actn:				1	Obj Strk:			
Unit	2 : 1	Alchl/Drgs:	0	Speed:	45 MPH	Dir:	W	Veh Mnvr/Ped Actn:				4	Obj Strk:			

**North Carolina Department of Transportation
Traffic Engineering Accident Analysis System
Strip Analysis Report**

Acc No	Crash ID	Milepost	Date	Accident Type	Total Damage	Injuries				Condition			Road		Trfc Ctl	
						F	A	B	C	R	L	W	Ch	Ci	Dv	Op
354	103065862	24.350	01/12/2011 15:30	RAN OFF ROAD - RIGHT	\$ 15700	0	0	0	1	4	1	1	5	0	0	
Unit	1 : 1	Alchl/Drgs:	0	Speed: 50 MPH	Dir: E	Veh Mnvr/Ped Actn:				4	Obj Strk:		44			
355	102768314	24.390	01/12/2010 09:40	FIXED OBJECT	\$ 2500	0	0	0	0	4	1	2	7	0	0	
Unit	1 : 4	Alchl/Drgs:	0	Speed: 60 MPH	Dir: W	Veh Mnvr/Ped Actn:				4	Obj Strk:		42			
356	102774315	24.398	01/21/2010 11:45	FIXED OBJECT	\$ 5000	0	0	0	0	2	1	3	7	0	0	
Unit	1 : 1	Alchl/Drgs:	0	Speed: 55 MPH	Dir: NW	Veh Mnvr/Ped Actn:				4	Obj Strk:		62			
357	102752424	24.410	12/24/2009 12:20	REAR END, SLOW OR STOP	\$ 4000	0	0	0	0	1	1	1	7	4	0	
Unit	1 : 1	Alchl/Drgs:	0	Speed: 60 MPH	Dir: E	Veh Mnvr/Ped Actn:				4	Obj Strk:					
Unit	2 : 2	Alchl/Drgs:	0	Speed: 40 MPH	Dir: E	Veh Mnvr/Ped Actn:				11	Obj Strk:					
358	103414360	24.410	03/29/2012 07:40	REAR END, SLOW OR STOP	\$ 5000	0	0	0	0	1	1	1	3	0	0	
Unit	1 : 1	Alchl/Drgs:	0	Speed: 55 MPH	Dir: W	Veh Mnvr/Ped Actn:				5	Obj Strk:					
Unit	2 : 14	Alchl/Drgs:	0	Speed: 60 MPH	Dir: W	Veh Mnvr/Ped Actn:				4	Obj Strk:					
359	103033003	24.420	11/22/2010 12:55	REAR END, SLOW OR STOP	\$ 2700	0	0	0	0	1	1	2	1	0	0	
Unit	1 : 15	Alchl/Drgs:	0	Speed: 55 MPH	Dir: W	Veh Mnvr/Ped Actn:				4	Obj Strk:					
Unit	2 : 2	Alchl/Drgs:	0	Speed: 55 MPH	Dir: W	Veh Mnvr/Ped Actn:				11	Obj Strk:					
360	103398312	24.420	03/09/2012 11:00	OTHER COLLISION WITH VEHICLE	\$ 500	0	0	0	0	1	1	2	1	0	0	
Unit	1 : 25	Alchl/Drgs:	0	Speed: 60 MPH	Dir: W	Veh Mnvr/Ped Actn:				4	Obj Strk:					
Unit	2 : 4	Alchl/Drgs:	0	Speed: 60 MPH	Dir: W	Veh Mnvr/Ped Actn:				4	Obj Strk:					
361	103243506	24.430	09/05/2011 09:55	RAN OFF ROAD - LEFT	\$ 4500	0	0	0	0	2	1	2	3	0	0	
Unit	1 : 1	Alchl/Drgs:	0	Speed: 50 MPH	Dir: W	Veh Mnvr/Ped Actn:				4	Obj Strk:		44			
362	102869533	24.520	05/21/2010 12:15	SIDESWIPE, SAME DIRECTION	\$ 2050	0	0	0	0	2	1	3	3	0	0	
Unit	1 : 14	Alchl/Drgs:	0	Speed: 55 MPH	Dir: SE	Veh Mnvr/Ped Actn:				5	Obj Strk:					
Unit	2 : 1	Alchl/Drgs:	0	Speed: 55 MPH	Dir: SE	Veh Mnvr/Ped Actn:				4	Obj Strk:					
363	102908605	24.520	07/10/2010 10:15	FIXED OBJECT	\$ 1000	0	0	0	0	1	1	1	1	0	10	1
Unit	1 : 4	Alchl/Drgs:	0	Speed: 55 MPH	Dir: S	Veh Mnvr/Ped Actn:				4	Obj Strk:		48			
364	102953660	24.520	09/01/2010 06:35	MOVABLE OBJECT	\$ 800	0	0	0	0	1	5	1	7	2	0	
Unit	1 : 1	Alchl/Drgs:	0	Speed: 55 MPH	Dir: E	Veh Mnvr/Ped Actn:				4	Obj Strk:		18			

**North Carolina Department of Transportation
Traffic Engineering Accident Analysis System
Strip Analysis Report**

Acc No	Crash ID	Milepost	Date	Accident Type	Total Damage	Injuries				Condition			Road		Trfc Ctl	
						F	A	B	C	R	L	W	Ch	Ci	Dv	Op
365	102974290	24.520	09/26/2010 10:00	FIXED OBJECT	\$ 500	0	0	0	0	2	1	3	7	1	0	
Unit	1 : 1	Alchl/Drgs:	0	Speed: 50 MPH Dir: SE		Veh Mnvr/Ped Actn:				4	Obj Strk:		64			
366	102973460	24.520	09/26/2010 11:45	FIXED OBJECT	\$ 1200	0	0	0	0	2	1	2	3	3	0	
Unit	1 : 1	Alchl/Drgs:	0	Speed: 55 MPH Dir: E		Veh Mnvr/Ped Actn:				15	Obj Strk:		44			
367	103157756	24.520	05/09/2011 05:00	ANIMAL	\$ 1000	0	0	0	0	1	5	1	3	0	0	
Unit	1 : 14	Alchl/Drgs:	0	Speed: 60 MPH Dir: E		Veh Mnvr/Ped Actn:				4	Obj Strk:		17			
368	103168557	24.520	06/01/2011 15:39	SIDESWIPE, SAME DIRECTION	\$ 95	0	0	0	0	1	1	1	1	0	0	
Unit	1 : 2	Alchl/Drgs:	0	Speed: 65 MPH Dir: N		Veh Mnvr/Ped Actn:				5	Obj Strk:					
Unit	2 : 1	Alchl/Drgs:	0	Speed: 60 MPH Dir: N		Veh Mnvr/Ped Actn:				4	Obj Strk:					
369	103179144	24.520	06/15/2011 18:07	OTHER COLLISION WITH VEHICLE	\$ 3500	0	0	0	0	2	1	2	3	0	0	
Unit	1 : 1	Alchl/Drgs:	0	Speed: 55 MPH Dir: E		Veh Mnvr/Ped Actn:				4	Obj Strk:					
Unit	2 : 2	Alchl/Drgs:	0	Speed: 55 MPH Dir: E		Veh Mnvr/Ped Actn:				4	Obj Strk:					
370	103304263	24.520	11/16/2011 17:26	REAR END, SLOW OR STOP	\$ 1100	0	0	0	1	2	5	2	1	0	0	
Unit	1 : 1	Alchl/Drgs:	0	Speed: 40 MPH Dir: N		Veh Mnvr/Ped Actn:				4	Obj Strk:					
Unit	2 : 1	Alchl/Drgs:	0	Speed: 35 MPH Dir: N		Veh Mnvr/Ped Actn:				11	Obj Strk:					
371	102653206	24.530	08/06/2009 12:10	SIDESWIPE, SAME DIRECTION	\$ 3500	0	0	0	1	1	1	1	3	0	0	
Unit	1 : 15	Alchl/Drgs:	0	Speed: 50 MPH Dir: W		Veh Mnvr/Ped Actn:				5	Obj Strk:					
Unit	2 : 2	Alchl/Drgs:	0	Speed: 50 MPH Dir: W		Veh Mnvr/Ped Actn:				4	Obj Strk:		48			
372	102697099	24.538	10/02/2009 19:17	REAR END, SLOW OR STOP	\$ 1250	0	0	0	0	1	2	2	3	0	0	
Unit	1 : 4	Alchl/Drgs:	0	Speed: 40 MPH Dir: E		Veh Mnvr/Ped Actn:				11	Obj Strk:					
Unit	2 : 1	Alchl/Drgs:	0	Speed: 40 MPH Dir: E		Veh Mnvr/Ped Actn:				11	Obj Strk:					
373	102701040	24.580	10/09/2009 19:50	REAR END, SLOW OR STOP	\$ 5000	0	0	0	0	1	5	1	1	0	0	
Unit	1 : 1	Alchl/Drgs:	0	Speed: 35 MPH Dir: E		Veh Mnvr/Ped Actn:				4	Obj Strk:					
Unit	2 : 1	Alchl/Drgs:	0	Speed: 0 MPH Dir: E		Veh Mnvr/Ped Actn:				1	Obj Strk:					
374	102691180	24.620	09/29/2009 17:28	REAR END, SLOW OR STOP	\$ 1500	0	0	0	0	1	1	1	1	0	0	
Unit	1 : 4	Alchl/Drgs:	0	Speed: 55 MPH Dir: E		Veh Mnvr/Ped Actn:				4	Obj Strk:					
Unit	2 : 1	Alchl/Drgs:	0	Speed: 55 MPH Dir: E		Veh Mnvr/Ped Actn:				11	Obj Strk:					

**North Carolina Department of Transportation
Traffic Engineering Accident Analysis System
Strip Analysis Report**

Acc No	Crash ID	Milepost	Date	Accident Type	Total Damage	Injuries				Condition			Road		Trfc Ctl	
						F	A	B	C	R	L	W	Ch	Ci	Dv	Op
375	102908662	24.620	07/10/2010 15:30	REAR END, SLOW OR STOP	\$ 1600	0	0	0	0	1	1	1	1	0	0	
Unit	1 : 1	Alchl/Drgs:	0	Speed: 45 MPH Dir: W		Veh Mnvr/Ped Actn:				4	Obj Strk:					
Unit	2 : 1	Alchl/Drgs:	0	Speed: 45 MPH Dir: W		Veh Mnvr/Ped Actn:				11	Obj Strk:					
376	102757656	24.638	12/28/2009 11:56	REAR END, SLOW OR STOP	\$ 1800	0	0	0	0	1	1	1	1	0	0	
Unit	1 : 2	Alchl/Drgs:	0	Speed: 55 MPH Dir: E		Veh Mnvr/Ped Actn:				4	Obj Strk:					
Unit	2 : 1	Alchl/Drgs:	0	Speed: 55 MPH Dir: E		Veh Mnvr/Ped Actn:				11	Obj Strk:					
377	102897627	24.638	06/07/2010 18:26	FIXED OBJECT	\$ 3000	0	0	0	1	1	1	1	3	0	0	
Unit	1 : 1	Alchl/Drgs:	0	Speed: 55 MPH Dir: S		Veh Mnvr/Ped Actn:				4	Obj Strk:		42			
378	102898145	24.638	06/25/2010 15:37	REAR END, SLOW OR STOP	\$ 12000	0	0	0	2	1	1	2	3	0	0	
Unit	1 : 1	Alchl/Drgs:	0	Speed: 50 MPH Dir: E		Veh Mnvr/Ped Actn:				4	Obj Strk:					
Unit	2 : 1	Alchl/Drgs:	0	Speed: 50 MPH Dir: E		Veh Mnvr/Ped Actn:				11	Obj Strk:					
Unit	3 : 2	Alchl/Drgs:	0	Speed: 50 MPH Dir: E		Veh Mnvr/Ped Actn:				1	Obj Strk:					
379	103024448	24.638	11/27/2010 11:46	ANIMAL	\$ 2000	0	0	0	0	1	1	1	3	0	0	
Unit	1 : 1	Alchl/Drgs:	0	Speed: 55 MPH Dir: W		Veh Mnvr/Ped Actn:				4	Obj Strk:		17			
380	103146479	24.638	04/28/2011 01:25	FIXED OBJECT	\$ 3900	0	0	0	0	2	5	3	3	0	0	
Unit	1 : 1	Alchl/Drgs:	0	Speed: 60 MPH Dir: W		Veh Mnvr/Ped Actn:				4	Obj Strk:		44			
381	102940880	24.710	08/18/2010 19:29	REAR END, SLOW OR STOP	\$ 4700	0	0	0	0	3	1	3	1	0	0	
Unit	1 : 1	Alchl/Drgs:	0	Speed: 60 MPH Dir: S		Veh Mnvr/Ped Actn:				4	Obj Strk:					
Unit	2 : 4	Alchl/Drgs:	0	Speed: 30 MPH Dir: S		Veh Mnvr/Ped Actn:				4	Obj Strk:					
382	102738830	24.720	12/08/2009 06:40	SIDESWIPE, SAME DIRECTION	\$ 10300	0	0	1	0	1	5	2	3	0	0	
Unit	1 : 4	Alchl/Drgs:	0	Speed: 55 MPH Dir: SE		Veh Mnvr/Ped Actn:				5	Obj Strk:					
Unit	2 : 11	Alchl/Drgs:	0	Speed: 55 MPH Dir: SE		Veh Mnvr/Ped Actn:				4	Obj Strk:					
383	102728312	24.738	11/21/2009 12:20	REAR END, SLOW OR STOP	\$ 6800	0	0	0	0	1	1	1	7	0	10	1
Unit	1 : 1	Alchl/Drgs:	0	Speed: 55 MPH Dir: E		Veh Mnvr/Ped Actn:				4	Obj Strk:		48			
Unit	2 : 10	Alchl/Drgs:	0	Speed: 45 MPH Dir: E		Veh Mnvr/Ped Actn:				5	Obj Strk:					
384	103123358	24.738	03/25/2011 15:00	REAR END, SLOW OR STOP	\$ 9000	0	0	0	3	1	1	2	3	2	0	
Unit	1 : 4	Alchl/Drgs:	0	Speed: 45 MPH Dir: NW		Veh Mnvr/Ped Actn:				11	Obj Strk:					
Unit	2 : 4	Alchl/Drgs:	0	Speed: 45 MPH Dir: NW		Veh Mnvr/Ped Actn:				11	Obj Strk:					

**North Carolina Department of Transportation
Traffic Engineering Accident Analysis System
Strip Analysis Report**

Acc No	Crash ID	Milepost	Date	Accident Type	Total Damage	Injuries				Condition			Road		Trfc Ctl	
						F	A	B	C	R	L	W	Ch	Ci	Dv	Op
Unit	3 : 4	Alchl/Drgs:	0	Speed:	45 MPH Dir: NW	Veh Mnvr/Ped Actn:				15	Obj Strk:		18			
385	103200073	24.738	07/08/2011 19:04	FIXED OBJECT	\$ 5400	0	0	0	0	3	1	2	3	0	0	
Unit	1 : 1	Alchl/Drgs:	0	Speed:	60 MPH Dir: E	Veh Mnvr/Ped Actn:				4	Obj Strk:		44			
386	102789991	24.788	01/24/2010 17:00	FIXED OBJECT	\$ 3000	0	0	0	0	2	1	3	3	0	0	
Unit	1 : 4	Alchl/Drgs:	0	Speed:	50 MPH Dir: E	Veh Mnvr/Ped Actn:				4	Obj Strk:		42			
387	102789994	24.788	01/24/2010 17:05	REAR END, SLOW OR STOP	\$ 4800	0	0	0	2	2	1	2	3	0		
Unit	1 : 4	Alchl/Drgs:	0	Speed:	50 MPH Dir: W	Veh Mnvr/Ped Actn:				1	Obj Strk:					
Unit	2 : 4	Alchl/Drgs:	0	Speed:	50 MPH Dir: E	Veh Mnvr/Ped Actn:				4	Obj Strk:					
388	102657279	24.800	08/05/2009 15:14	SIDESWIPE, SAME DIRECTION	\$ 2000	0	0	0	0	2	1	3	1	0	0	
Unit	1 : 14	Alchl/Drgs:	0	Speed:	55 MPH Dir: W	Veh Mnvr/Ped Actn:				4	Obj Strk:					
Unit	2 : 2	Alchl/Drgs:	0	Speed:	55 MPH Dir: W	Veh Mnvr/Ped Actn:				4	Obj Strk:					
389	102784138	24.810	02/05/2010 16:34	FIXED OBJECT	\$ 1000	0	0	0	0	6	1	3	5	0	0	
Unit	1 : 1	Alchl/Drgs:	0	Speed:	55 MPH Dir: S	Veh Mnvr/Ped Actn:				5	Obj Strk:		42			
390	103444671	24.820	05/01/2012 18:13	REAR END, SLOW OR STOP	\$ 10500	0	0	0	0	1	1	2	1	0	0	
Unit	1 : 14	Alchl/Drgs:	0	Speed:	25 MPH Dir: E	Veh Mnvr/Ped Actn:				4	Obj Strk:					
Unit	2 : 1	Alchl/Drgs:	0	Speed:	35 MPH Dir: E	Veh Mnvr/Ped Actn:				1	Obj Strk:					
391	102765301	24.838	11/15/2009 05:55	ANIMAL	\$ 2200	0	0	0	0	1	5	1	1	0	0	
Unit	1 : 1	Alchl/Drgs:	0	Speed:	60 MPH Dir: W	Veh Mnvr/Ped Actn:				4	Obj Strk:		17			
392	102827298	24.838	03/29/2010 13:31	REAR END, SLOW OR STOP	\$ 5200	0	0	0	1	1	1	1	1	0	0	
Unit	1 : 1	Alchl/Drgs:	0	Speed:	0 MPH Dir: E	Veh Mnvr/Ped Actn:				1	Obj Strk:					
Unit	2 : 1	Alchl/Drgs:	0	Speed:	15 MPH Dir: E	Veh Mnvr/Ped Actn:				11	Obj Strk:					
Unit	3 : 4	Alchl/Drgs:	0	Speed:	65 MPH Dir: E	Veh Mnvr/Ped Actn:				4	Obj Strk:					
393	102901421	24.838	06/08/2010 15:07	SIDESWIPE, SAME DIRECTION	\$ 2200	0	0	0	0	1	1	1	1	0	0	
Unit	1 : 4	Alchl/Drgs:	0	Speed:	55 MPH Dir: E	Veh Mnvr/Ped Actn:				4	Obj Strk:					
Unit	2 : 4	Alchl/Drgs:	0	Speed:	55 MPH Dir: E	Veh Mnvr/Ped Actn:				4	Obj Strk:					
394	102903627	24.838	07/03/2010 12:10	REAR END, SLOW OR STOP	\$ 300	0	0	0	1	1	1	1	1	0	10 1	
Unit	1 : 1	Alchl/Drgs:	0	Speed:	45 MPH Dir: E	Veh Mnvr/Ped Actn:				4	Obj Strk:					

**North Carolina Department of Transportation
Traffic Engineering Accident Analysis System
Strip Analysis Report**

Acc No	Crash ID	Milepost	Date	Accident Type	Total Damage	Injuries				Condition			Road		Trfc Ctl	
						F	A	B	C	R	L	W	Ch	Ci	Dv	Op
Unit	2 : 1	Alchl/Drgs:	0	Speed:	45 MPH	Dir:	E	Veh Mnvr/Ped Actn:				1	Obj Strk:			
395	102932028	24.838	08/08/2010 14:48	REAR END, SLOW OR STOP	\$ 10500	0	0	0	0	1	1	1	3	0	0	
Unit	1 : 1	Alchl/Drgs:	0	Speed:	35 MPH	Dir:	E	Veh Mnvr/Ped Actn:				4	Obj Strk:			
Unit	2 : 4	Alchl/Drgs:	0	Speed:	35 MPH	Dir:	E	Veh Mnvr/Ped Actn:				11	Obj Strk:			
Unit	3 : 5	Alchl/Drgs:	0	Speed:	35 MPH	Dir:	E	Veh Mnvr/Ped Actn:				1	Obj Strk:			
396	103104153	24.838	03/04/2011 14:10	REAR END, SLOW OR STOP	\$ 20000	0	0	0	1	1	1	2	5	0	2	1
Unit	1 : 1	Alchl/Drgs:	0	Speed:	55 MPH	Dir:	N	Veh Mnvr/Ped Actn:				4	Obj Strk:			
Unit	2 : 1	Alchl/Drgs:	0	Speed:	0 MPH	Dir:	N	Veh Mnvr/Ped Actn:				4	Obj Strk: 42			
397	103287472	24.838	10/28/2011 18:28	REAR END, SLOW OR STOP	\$ 6700	0	0	0	0	2	5	3	3	0	0	
Unit	1 : 4	Alchl/Drgs:	0	Speed:	60 MPH	Dir:	W	Veh Mnvr/Ped Actn:				1	Obj Strk: 18			
Unit	2 : 2	Alchl/Drgs:	0	Speed:	60 MPH	Dir:	W	Veh Mnvr/Ped Actn:				11	Obj Strk:			
Unit	3 : 4	Alchl/Drgs:	0	Speed:	60 MPH	Dir:	W	Veh Mnvr/Ped Actn:				4	Obj Strk:			
398	102943464	24.888	08/22/2010 07:56	FIXED OBJECT	\$ 5000	0	0	0	1	1	1	1	1	0	0	
Unit	1 : 1	Alchl/Drgs:	0	Speed:	55 MPH	Dir:	E	Veh Mnvr/Ped Actn:				4	Obj Strk: 48			
399	103481712	24.888	06/22/2012 16:13	REAR END, SLOW OR STOP	\$ 14500	0	0	2	0	2	1	2	3	0	0	
Unit	1 : 1	Alchl/Drgs:	0	Speed:	0 MPH	Dir:	W	Veh Mnvr/Ped Actn:				1	Obj Strk:			
Unit	2 : 1	Alchl/Drgs:	0	Speed:	5 MPH	Dir:	W	Veh Mnvr/Ped Actn:				11	Obj Strk:			
Unit	3 : 10	Alchl/Drgs:	0	Speed:	0 MPH	Dir:	W	Veh Mnvr/Ped Actn:				1	Obj Strk:			
Unit	4 : 1	Alchl/Drgs:	0	Speed:	0 MPH	Dir:	W	Veh Mnvr/Ped Actn:				1	Obj Strk:			
Unit	5 : 1	Alchl/Drgs:	0	Speed:	60 MPH	Dir:	W	Veh Mnvr/Ped Actn:				4	Obj Strk:			
400	102920025	24.920	07/18/2010 15:39	OTHER COLLISION WITH VEHICLE	\$ 3500	0	0	0	0	3	1	3	3	0	0	
Unit	1 : 4	Alchl/Drgs:	0	Speed:	55 MPH	Dir:	W	Veh Mnvr/Ped Actn:				4	Obj Strk:			
Unit	2 : 14	Alchl/Drgs:	7	Speed:	55 MPH	Dir:	W	Veh Mnvr/Ped Actn:				1	Obj Strk:			
401	103096674	24.920	02/21/2011 12:30	OTHER NON-COLLISION	\$ 3000	0	0	0	0	1	5	1	3	0	0	
Unit	1 : 1	Alchl/Drgs:	7	Speed:	60 MPH	Dir:	W	Veh Mnvr/Ped Actn:				4	Obj Strk:			
402	103191175	24.920	07/01/2011 14:20	REAR END, SLOW OR STOP	\$ 1250	0	0	0	0	1	1	1	1	0	0	
Unit	1 : 1	Alchl/Drgs:	0	Speed:	20 MPH	Dir:	W	Veh Mnvr/Ped Actn:				4	Obj Strk:			
Unit	2 : 5	Alchl/Drgs:	0	Speed:	10 MPH	Dir:	W	Veh Mnvr/Ped Actn:				11	Obj Strk:			

**North Carolina Department of Transportation
Traffic Engineering Accident Analysis System
Strip Analysis Report**

Acc No	Crash ID	Milepost	Date	Accident Type	Total Damage	Injuries				Condition			Road		Trfc Ctl	
						F	A	B	C	R	L	W	Ch	Ci	Dv	Op
403	103269005	24.920	09/21/2011 15:53	FIXED OBJECT	\$ 1000	0	0	0	0	2	1	2	1	0	0	
Unit	1 : 4	Alchl/Drgs:	0	Speed: 60 MPH	Dir: S	Veh Mnvr/Ped Actn:				4	Obj Strk:		42			
404	103342915	24.920	01/02/2012 00:31	FIXED OBJECT	\$ 2500	0	0	0	0	1	5	1	3	0	0	
Unit	1 : 1	Alchl/Drgs:	0	Speed: 60 MPH	Dir: N	Veh Mnvr/Ped Actn:				4	Obj Strk:		44			
405	102707661	24.938	10/16/2009 17:11	REAR END, SLOW OR STOP	\$ 9000	0	0	0	1	1	1	2	3	0		
Unit	1 : 1	Alchl/Drgs:	0	Speed: 30 MPH	Dir: W	Veh Mnvr/Ped Actn:				4	Obj Strk:					
Unit	2 : 4	Alchl/Drgs:	0	Speed: 30 MPH	Dir: W	Veh Mnvr/Ped Actn:				11	Obj Strk:					
406	102767704	24.938	12/23/2009 18:09	REAR END, SLOW OR STOP	\$ 3300	0	0	0	0	4	5	1	1	0	0	
Unit	1 : 14	Alchl/Drgs:	0	Speed: 50 MPH	Dir: E	Veh Mnvr/Ped Actn:				4	Obj Strk:					
Unit	2 : 31	Alchl/Drgs:	0	Speed: 50 MPH	Dir: E	Veh Mnvr/Ped Actn:				4	Obj Strk:					
407	102848679	24.938	04/23/2010 03:10	SIDESWIPE, SAME DIRECTION	\$ 3000	0	0	0	0	1	5	1	3	0	14	1
Unit	1 : 1	Alchl/Drgs:	7	Speed: 35 MPH	Dir: W	Veh Mnvr/Ped Actn:				5	Obj Strk:					
Unit	2 : 4	Alchl/Drgs:	0	Speed: 55 MPH	Dir: W	Veh Mnvr/Ped Actn:				4	Obj Strk:					
408	102886109	24.938	06/11/2010 15:38	REAR END, SLOW OR STOP	\$ 7000	0	0	0	0	1	1	2	3	0	0	
Unit	1 : 4	Alchl/Drgs:	0	Speed: 35 MPH	Dir: W	Veh Mnvr/Ped Actn:				4	Obj Strk:					
Unit	2 : 1	Alchl/Drgs:	0	Speed: 35 MPH	Dir: W	Veh Mnvr/Ped Actn:				11	Obj Strk:					
409	103051147	24.938	12/25/2010 09:39	REAR END, SLOW OR STOP	\$ 1500	0	0	0	0	5	1	4	1	1	0	
Unit	1 : 1	Alchl/Drgs:	0	Speed: 40 MPH	Dir: W	Veh Mnvr/Ped Actn:				4	Obj Strk:					
Unit	2 : 4	Alchl/Drgs:	0	Speed: 40 MPH	Dir: W	Veh Mnvr/Ped Actn:				11	Obj Strk:					
410	103051218	24.938	12/25/2010 09:39	REAR END, SLOW OR STOP	\$ 4200	0	0	0	0	5	1	4	1	1	0	
Unit	1 : 1	Alchl/Drgs:	0	Speed: 45 MPH	Dir: W	Veh Mnvr/Ped Actn:				4	Obj Strk:					
Unit	2 : 2	Alchl/Drgs:	0	Speed: 40 MPH	Dir: W	Veh Mnvr/Ped Actn:				11	Obj Strk:					
411	103236610	24.938	08/26/2011 16:52	FIXED OBJECT	\$ 3250	0	0	0	0	1	1	1	1	0	0	
Unit	1 : 1	Alchl/Drgs:	0	Speed: 45 MPH	Dir: N	Veh Mnvr/Ped Actn:				5	Obj Strk:		42			
Unit	2 : 2	Alchl/Drgs:	0	Speed: 60 MPH	Dir: N	Veh Mnvr/Ped Actn:				4	Obj Strk:					
412	102770478	25.000	12/12/2009 06:29	REAR END, SLOW OR STOP	\$ 1250	0	0	0	1	1	4	1	1	0	0	1
Unit	1 : 1	Alchl/Drgs:	0	Speed: 70 MPH	Dir: N	Veh Mnvr/Ped Actn:				4	Obj Strk:					
Unit	2 : 1	Alchl/Drgs:	0	Speed: 65 MPH	Dir: N	Veh Mnvr/Ped Actn:				4	Obj Strk:					

**North Carolina Department of Transportation
Traffic Engineering Accident Analysis System
Strip Analysis Report**

Acc No	Crash ID	Milepost	Date	Accident Type	Total Damage	Injuries				Condition			Road		Trfc Ctl	
						F	A	B	C	R	L	W	Ch	Ci	Dv	Op
413	103192456	25.010	06/30/2011 16:28	REAR END, SLOW OR STOP	\$ 10200	0	0	1	0	1	1	1	1	0	0	
Unit	1 : 14	Alchl/Drgs:	0	Speed: 35 MPH Dir: W		Veh Mnvr/Ped Actn:				4	Obj Strk:					
Unit	2 : 1	Alchl/Drgs:	0	Speed: 15 MPH Dir: W		Veh Mnvr/Ped Actn:				4	Obj Strk:					
Unit	3 : 4	Alchl/Drgs:	0	Speed: 15 MPH Dir: W		Veh Mnvr/Ped Actn:				4	Obj Strk:					
414	102677384	25.038	09/20/2009 10:31	FIXED OBJECT	\$ 2000	0	0	0	0	3	1	3	1	0	0	
Unit	1 : 1	Alchl/Drgs:	0	Speed: 40 MPH Dir: W		Veh Mnvr/Ped Actn:				4	Obj Strk:		48			
415	102707344	25.038	10/16/2009 18:00	SIDESWIPE, SAME DIRECTION	\$ 1000	0	0	0	0	1	1	2	3	0	0	
Unit	1 : 12	Alchl/Drgs:	7	Speed: 0 MPH Dir: E		Veh Mnvr/Ped Actn:				5	Obj Strk:					
Unit	2 : 1	Alchl/Drgs:	0	Speed: 55 MPH Dir: E		Veh Mnvr/Ped Actn:				4	Obj Strk:					
416	102750934	25.038	12/21/2009 08:15	FIXED OBJECT	\$ 4100	0	0	0	0	4	1	1	5	0	0	
Unit	1 : 14	Alchl/Drgs:	0	Speed: 55 MPH Dir: W		Veh Mnvr/Ped Actn:				4	Obj Strk:					
Unit	2 : 1	Alchl/Drgs:	0	Speed: 60 MPH Dir: W		Veh Mnvr/Ped Actn:				4	Obj Strk:		18			
417	102751978	25.038	12/21/2009 08:20	FIXED OBJECT	\$ 900	0	0	0	0	4	1	1	7	0	0	
Unit	1 : 2	Alchl/Drgs:	0	Speed: 50 MPH Dir: E		Veh Mnvr/Ped Actn:				4	Obj Strk:		48			
418	102768613	25.038	01/12/2010 10:30	FIXED OBJECT	\$ 50	0	0	0	0	4	1	2	3	0	0	
Unit	1 : 2	Alchl/Drgs:	0	Speed: 50 MPH Dir: N		Veh Mnvr/Ped Actn:				4	Obj Strk:		58			
419	102768630	25.038	01/12/2010 11:23	FIXED OBJECT	\$ 2500	0	0	0	0	4	1	2	3	0	0	
Unit	1 : 1	Alchl/Drgs:	0	Speed: 50 MPH Dir: N		Veh Mnvr/Ped Actn:				4	Obj Strk:		48			
420	102780641	25.038	02/02/2010 16:35	FIXED OBJECT	\$ 2000	0	0	0	0	2	1	2	1	0	0	
Unit	1 : 1	Alchl/Drgs:	7	Speed: 55 MPH Dir: E		Veh Mnvr/Ped Actn:				4	Obj Strk:		48			
421	102841745	25.038	04/08/2010 15:00	SIDESWIPE, SAME DIRECTION	\$ 1200	0	0	0	0	2	1	3	1	0	0	
Unit	1 : 1	Alchl/Drgs:	0	Speed: 55 MPH Dir: E		Veh Mnvr/Ped Actn:				4	Obj Strk:					
Unit	2 : 1	Alchl/Drgs:	0	Speed: 55 MPH Dir: E		Veh Mnvr/Ped Actn:				4	Obj Strk:					
422	103196287	25.038	07/06/2011 19:06	FIXED OBJECT	\$ 9600	0	0	0	1	1	1	2	1	0	0	
Unit	1 : 2	Alchl/Drgs:	0	Speed: 60 MPH Dir: SE		Veh Mnvr/Ped Actn:				5	Obj Strk:		42			
Unit	2 : 3	Alchl/Drgs:	0	Speed: 0 MPH Dir: SE		Veh Mnvr/Ped Actn:				1	Obj Strk:					
Unit	3 : 2	Alchl/Drgs:	0	Speed: 0 MPH Dir: SE		Veh Mnvr/Ped Actn:				1	Obj Strk:					

**North Carolina Department of Transportation
Traffic Engineering Accident Analysis System
Strip Analysis Report**

Acc No	Crash ID	Milepost	Date	Accident Type	Total Damage	Injuries				Condition			Road		Trfc Ctl	
						F	A	B	C	R	L	W	Ch	Ci	Dv	Op
423	103244821	25.038	09/06/2011 17:15	REAR END, SLOW OR STOP	\$ 3000	0	0	0	1	1	1	2	3	0	0	
Unit	1 : 1	Alchl/Drgs:	0	Speed: 60 MPH Dir: SE		Veh Mnvr/Ped Actn:				4	Obj Strk:					
Unit	2 : 2	Alchl/Drgs:	0	Speed: 60 MPH Dir: SE		Veh Mnvr/Ped Actn:				1	Obj Strk:					
424	103281305	25.038	10/21/2011 08:45	RIGHT TURN, DIFFERENT ROADWAYS	\$ 4500	0	0	0	0	1	1	1	7	0	2	1
Unit	1 : 1	Alchl/Drgs:	0	Speed: 30 MPH Dir: W		Veh Mnvr/Ped Actn:				4	Obj Strk:		59			
Unit	2 : 2	Alchl/Drgs:	0	Speed: 40 MPH Dir: W		Veh Mnvr/Ped Actn:				4	Obj Strk:					
425	103353856	25.038	01/11/2012 09:38	FIXED OBJECT	\$ 1000	0	0	0	2	2	1	3	1	0	0	
Unit	1 : 1	Alchl/Drgs:	0	Speed: 60 MPH Dir: E		Veh Mnvr/Ped Actn:				4	Obj Strk:		44			
426	102767709	25.138	12/23/2009 01:22	FIXED OBJECT	\$ 6050	0	0	0	0	6	5	1	7	0		
Unit	1 : 15	Alchl/Drgs:	0	Speed: 25 MPH Dir: E		Veh Mnvr/Ped Actn:				4	Obj Strk:					
Unit	2 : 1	Alchl/Drgs:	0	Speed: 55 MPH Dir: E		Veh Mnvr/Ped Actn:				4	Obj Strk:		48			
427	103509947	25.138	07/27/2012 14:34	JACKKNIFE	\$ 21200	0	0	0	0	1	1	2	1	0	0	
Unit	1 : 14	Alchl/Drgs:	0	Speed: 50 MPH Dir: W		Veh Mnvr/Ped Actn:				4	Obj Strk:		42			
Unit	2 : 1	Alchl/Drgs:	0	Speed: 15 MPH Dir: W		Veh Mnvr/Ped Actn:				11	Obj Strk:		44			
428	102779644	25.151	02/01/2010 07:44	FIXED OBJECT	\$ 4300	0	0	0	1	4	1	1	3	0	0	
Unit	1 : 2	Alchl/Drgs:	0	Speed: 55 MPH Dir: SE		Veh Mnvr/Ped Actn:				4	Obj Strk:		46			
Unit	2 : 4	Alchl/Drgs:	0	Speed: 60 MPH Dir: SE		Veh Mnvr/Ped Actn:				1	Obj Strk:					
429	103005632	25.157	11/01/2010 16:00	REAR END, SLOW OR STOP	\$ 2700	0	0	0	0	1	1	1	5	0	0	
Unit	1 : 2	Alchl/Drgs:	0	Speed: 60 MPH Dir: W		Veh Mnvr/Ped Actn:				4	Obj Strk:					
Unit	2 : 1	Alchl/Drgs:	0	Speed: 60 MPH Dir: W		Veh Mnvr/Ped Actn:				11	Obj Strk:					
430	103148984	25.220	05/02/2011 09:30	REAR END, SLOW OR STOP	\$ 1000	0	0	0	0	1	5	1	3	0	0	
Unit	1 : 1	Alchl/Drgs:	0	Speed: 60 MPH Dir: W		Veh Mnvr/Ped Actn:				4	Obj Strk:					
Unit	2 : 32	Alchl/Drgs:	7	Speed: 65 MPH Dir: W		Veh Mnvr/Ped Actn:				4	Obj Strk:					
431	102702477	25.238	10/23/2009 18:44	FIXED OBJECT	\$ 5500	0	0	0	0	2	5	3	1	0	0	
Unit	1 : 1	Alchl/Drgs:	0	Speed: 55 MPH Dir: W		Veh Mnvr/Ped Actn:				4	Obj Strk:		48			
432	102733523	25.238	12/02/2009 11:36	RAN OFF ROAD - RIGHT	\$ 3500	0	0	0	0	2	1	3	1	0	0	
Unit	1 : 1	Alchl/Drgs:	0	Speed: 60 MPH Dir: W		Veh Mnvr/Ped Actn:				4	Obj Strk:		34			

**North Carolina Department of Transportation
Traffic Engineering Accident Analysis System
Strip Analysis Report**

Acc No	Crash ID	Milepost	Date	Accident Type	Total Damage	Injuries				Condition			Road		Trfc Ctl	
						F	A	B	C	R	L	W	Ch	Ci	Dv	Op
433	102756359	25.238	12/02/2009 15:35	REAR END, SLOW OR STOP	\$ 8000	0	0	0	0	3	1	3	7	0	0	
Unit	1 : 1	Alchl/Drgs:	0	Speed: 50 MPH Dir: E		Veh Mnvr/Ped Actn:				4	Obj Strk:					
Unit	2 : 4	Alchl/Drgs:	0	Speed: 5 MPH Dir: E		Veh Mnvr/Ped Actn:				4	Obj Strk:					
434	102796203	25.238	01/24/2010 16:42	REAR END, SLOW OR STOP	\$ 7500	0	0	0	0	3	1	2	1	0		
Unit	1 : 1	Alchl/Drgs:	0	Speed: 45 MPH Dir: E		Veh Mnvr/Ped Actn:				4	Obj Strk:					
Unit	2 : 5	Alchl/Drgs:	0	Speed: 45 MPH Dir: E		Veh Mnvr/Ped Actn:				11	Obj Strk:					
435	102834887	25.238	04/01/2010 16:27	MOVABLE OBJECT	\$ 2000	0	0	0	0	1	1	1	3	0	0	
Unit	1 : 3	Alchl/Drgs:	0	Speed: 60 MPH Dir: E		Veh Mnvr/Ped Actn:				4	Obj Strk: 18					
436	102993560	25.238	10/24/2010 11:28	OTHER NON-COLLISION	\$ 500	0	0	0	0	1	1	1	1	0	0	
Unit	1 : 1	Alchl/Drgs:	0	Speed: 60 MPH Dir: W		Veh Mnvr/Ped Actn:				4	Obj Strk:					
437	103279210	25.238	10/16/2011 18:38	SIDESWIPE, SAME DIRECTION	\$ 1000	0	0	0	0	1	1	1	3	0	0	
Unit	1 : 1	Alchl/Drgs:	0	Speed: 50 MPH Dir: S		Veh Mnvr/Ped Actn:				16	Obj Strk:					
Unit	2 : 1	Alchl/Drgs:	0	Speed: 50 MPH Dir: S		Veh Mnvr/Ped Actn:				16	Obj Strk:					
438	103336680	25.238	12/22/2011 18:13	FIXED OBJECT	\$ 3900	0	0	0	0	2	5	2	7	0	0	
Unit	1 : 4	Alchl/Drgs:	0	Speed: 55 MPH Dir: W		Veh Mnvr/Ped Actn:				4	Obj Strk: 44					
439	103482374	25.238	06/23/2012 07:19	FIXED OBJECT	\$ 8800	0	0	0	0	1	1	1	1	0	0	
Unit	1 : 1	Alchl/Drgs:	1	Speed: 60 MPH Dir: W		Veh Mnvr/Ped Actn:				4	Obj Strk: 44					
Unit	2 : 2	Alchl/Drgs:	0	Speed: 55 MPH Dir: W		Veh Mnvr/Ped Actn:				4	Obj Strk:					
440	102897214	25.270	06/25/2010 07:04	FIXED OBJECT	\$ 7500	0	0	0	1	1	1	1	1	0	0	
Unit	1 : 4	Alchl/Drgs:	0	Speed: 55 MPH Dir: E		Veh Mnvr/Ped Actn:				4	Obj Strk: 48					
441	103374978	25.280	01/18/2012 16:27	OTHER NON-COLLISION	\$ 500	0	0	0	0	1	1	1	3	0	0	
Unit	1 : 2	Alchl/Drgs:	0	Speed: 65 MPH Dir: S		Veh Mnvr/Ped Actn:				4	Obj Strk:					
442	103270003	25.320	10/09/2011 20:44	ANIMAL	\$ 2500	0	0	0	0	1	5	1	1	0	0	
Unit	1 : 1	Alchl/Drgs:	0	Speed: 60 MPH Dir: NW		Veh Mnvr/Ped Actn:				4	Obj Strk: 17					
443	103419924	25.320	04/03/2012 15:49	REAR END, SLOW OR STOP	\$ 750	0	0	0	0	3	1	3	1	0	0	
Unit	1 : 1	Alchl/Drgs:	0	Speed: 50 MPH Dir: N		Veh Mnvr/Ped Actn:				4	Obj Strk:					
Unit	2 : 1	Alchl/Drgs:	0	Speed: 50 MPH Dir: N		Veh Mnvr/Ped Actn:				11	Obj Strk:					

**North Carolina Department of Transportation
Traffic Engineering Accident Analysis System
Strip Analysis Report**

Acc No	Crash ID	Milepost	Date	Accident Type	Total Damage	Injuries				Condition			Road		Trfc Ctl	
						F	A	B	C	R	L	W	Ch	Ci	Dv	Op
444	102779616	25.338	02/01/2010 08:38	FIXED OBJECT	\$ 1100	0	0	0	0	4	1	1	1	0	0	
Unit	1 : 2	Alchl/Drgs:	0	Speed: 60 MPH Dir: E		Veh Mnvr/Ped Actn:				4	Obj Strk:		46			
445	102838437	25.338	04/13/2010 17:01	REAR END, SLOW OR STOP	\$ 5400	0	0	0	1	1	1	1	1	0	0	
Unit	1 : 1	Alchl/Drgs:	0	Speed: 55 MPH Dir: N		Veh Mnvr/Ped Actn:				4	Obj Strk:					
Unit	2 : 2	Alchl/Drgs:	0	Speed: 55 MPH Dir: N		Veh Mnvr/Ped Actn:				1	Obj Strk:					
446	102864193	25.338	05/16/2010 16:27	SIDESWIPE, SAME DIRECTION	\$ 2000	0	0	0	0	1	1	2	3	0	0	
Unit	1 : 1	Alchl/Drgs:	0	Speed: 60 MPH Dir: W		Veh Mnvr/Ped Actn:				5	Obj Strk:					
Unit	2 : 1	Alchl/Drgs:	0	Speed: 60 MPH Dir: W		Veh Mnvr/Ped Actn:				4	Obj Strk:					
447	102891859	25.338	06/19/2010 07:50	SIDESWIPE, SAME DIRECTION	\$ 17000	0	0	0	2	1	1	2	3	9	10	1
Unit	1 : 2	Alchl/Drgs:	0	Speed: 60 MPH Dir: SE		Veh Mnvr/Ped Actn:				5	Obj Strk:		48			
Unit	2 : 1	Alchl/Drgs:	0	Speed: 55 MPH Dir: SE		Veh Mnvr/Ped Actn:				4	Obj Strk:		48			
448	102920213	25.338	07/24/2010 12:23	FIXED OBJECT	\$ 1500	0	0	0	0	1	1	1	1	0	0	
Unit	1 : 1	Alchl/Drgs:	0	Speed: 55 MPH Dir: W		Veh Mnvr/Ped Actn:				4	Obj Strk:		48			
449	102920256	25.338	07/24/2010 13:23	REAR END, SLOW OR STOP	\$ 5000	0	0	0	1	1	1	1	1	0	0	
Unit	1 : 1	Alchl/Drgs:	0	Speed: 55 MPH Dir: W		Veh Mnvr/Ped Actn:				4	Obj Strk:					
Unit	2 : 1	Alchl/Drgs:	0	Speed: 15 MPH Dir: W		Veh Mnvr/Ped Actn:				1	Obj Strk:					
450	103436818	25.338	04/27/2012 19:44	REAR END, SLOW OR STOP	\$ 600	0	0	0	0	1	1	1	1	0	0	
Unit	1 : 2	Alchl/Drgs:	0	Speed: 50 MPH Dir: S		Veh Mnvr/Ped Actn:				5	Obj Strk:					
Unit	2 : 1	Alchl/Drgs:	0	Speed: 50 MPH Dir: S		Veh Mnvr/Ped Actn:				11	Obj Strk:					
451	103471580	25.338	06/05/2012 16:32	FIXED OBJECT	\$ 3500	0	0	0	0	1	1	1	5	0	0	
Unit	1 : 15	Alchl/Drgs:	0	Speed: 60 MPH Dir: S		Veh Mnvr/Ped Actn:				5	Obj Strk:					
Unit	2 : 1	Alchl/Drgs:	0	Speed: 60 MPH Dir: S		Veh Mnvr/Ped Actn:				4	Obj Strk:		44			
452	102753761	25.388	12/17/2009 20:23	OTHER COLLISION WITH VEHICLE	\$ 3650	0	0	0	0	1	5	1	1	0	0	
Unit	1 : 4	Alchl/Drgs:	0	Speed: 45 MPH Dir: E		Veh Mnvr/Ped Actn:				5	Obj Strk:					
Unit	2 : 12	Alchl/Drgs:	0	Speed: 45 MPH Dir: E		Veh Mnvr/Ped Actn:				4	Obj Strk:					
Unit	3 : 1	Alchl/Drgs:	0	Speed: 45 MPH Dir: E		Veh Mnvr/Ped Actn:				4	Obj Strk:					

**North Carolina Department of Transportation
Traffic Engineering Accident Analysis System
Strip Analysis Report**

Acc No	Crash ID	Milepost	Date	Accident Type	Total Damage	Injuries				Condition			Road		Trfc Ctl	
						F	A	B	C	R	L	W	Ch	Ci	Dv	Op
453	103191324	25.395	07/02/2011 19:57	FIXED OBJECT	\$ 21000	0	0	1	1	1	1	1	1	0	0	
Unit	1 : 1	Alchl/Drgs:	0	Speed:	65 MPH Dir: W	Veh Mnvr/Ped Actn:				4	Obj Strk:		59			
454	102679595	25.438	08/17/2009 22:00	MOVABLE OBJECT	\$ 3000	0	0	0	0	1	1	1	1	0	0	
Unit	1 : 3	Alchl/Drgs:	0	Speed:	60 MPH Dir: E	Veh Mnvr/Ped Actn:				4	Obj Strk:		18			
455	103011601	25.438	11/12/2010 15:21	REAR END, SLOW OR STOP	\$ 2850	0	0	0	2	1	1	1	3	0	0	
Unit	1 : 2	Alchl/Drgs:	0	Speed:	60 MPH Dir: W	Veh Mnvr/Ped Actn:				4	Obj Strk:					
Unit	2 : 1	Alchl/Drgs:	0	Speed:	60 MPH Dir: W	Veh Mnvr/Ped Actn:				1	Obj Strk:					
Unit	3 : 1	Alchl/Drgs:	0	Speed:	60 MPH Dir: W	Veh Mnvr/Ped Actn:				1	Obj Strk:					
Unit	4 : 1	Alchl/Drgs:	0	Speed:	60 MPH Dir: W	Veh Mnvr/Ped Actn:				1	Obj Strk:					
456	103336685	25.438	12/22/2011 20:35	FIXED OBJECT	\$ 5900	0	0	0	0	2	5	2	4	0	0	
Unit	1 : 4	Alchl/Drgs:	0	Speed:	55 MPH Dir: W	Veh Mnvr/Ped Actn:				4	Obj Strk:		44			
457	102751747	25.470	12/22/2009 11:40	REAR END, SLOW OR STOP	\$ 3500	0	0	0	0	1	1	1	3	0	0	
Unit	1 : 10	Alchl/Drgs:	0	Speed:	45 MPH Dir: E	Veh Mnvr/Ped Actn:				4	Obj Strk:		44			
Unit	2 : 4	Alchl/Drgs:	0	Speed:	0 MPH Dir: E	Veh Mnvr/Ped Actn:				1	Obj Strk:					
458	102914299	25.520	07/16/2010 15:59	REAR END, SLOW OR STOP	\$ 14500	0	0	1	1	1	1	2	1	0	0	
Unit	1 : 1	Alchl/Drgs:	0	Speed:	55 MPH Dir: W	Veh Mnvr/Ped Actn:				4	Obj Strk:					
Unit	2 : 4	Alchl/Drgs:	0	Speed:	40 MPH Dir: W	Veh Mnvr/Ped Actn:				4	Obj Strk:					
Unit	3 : 2	Alchl/Drgs:	0	Speed:	40 MPH Dir: W	Veh Mnvr/Ped Actn:				4	Obj Strk:					
459	103095745	25.520	02/22/2011 09:50	REAR END, SLOW OR STOP	\$ 1500	0	0	0	0	1	1	1	1	0	0	
Unit	1 : 1	Alchl/Drgs:	0	Speed:	65 MPH Dir: N	Veh Mnvr/Ped Actn:				4	Obj Strk:					
Unit	2 : 1	Alchl/Drgs:	0	Speed:	65 MPH Dir: N	Veh Mnvr/Ped Actn:				4	Obj Strk:					
460	103288122	25.520	10/27/2011 13:45	REAR END, SLOW OR STOP	\$ 6200	0	0	0	0	1	1	1	1	0	0	
Unit	1 : 14	Alchl/Drgs:	0	Speed:	60 MPH Dir: W	Veh Mnvr/Ped Actn:				4	Obj Strk:					
Unit	2 : 1	Alchl/Drgs:	0	Speed:	0 MPH Dir: W	Veh Mnvr/Ped Actn:				1	Obj Strk:					
461	103208440	25.560	07/23/2011 10:45	MOVABLE OBJECT	\$ 1000	0	0	0	0	1	1	1	1	0	0	
Unit	1 : 14	Alchl/Drgs:	0	Speed:	60 MPH Dir: E	Veh Mnvr/Ped Actn:				4	Obj Strk:		18			
462	103190801	25.620	06/27/2011 20:46	REAR END, SLOW OR STOP	\$ 7200	0	0	0	1	1	5	1	2	0	10	1
Unit	1 : 1	Alchl/Drgs:	0	Speed:	60 MPH Dir: E	Veh Mnvr/Ped Actn:				4	Obj Strk:					

**North Carolina Department of Transportation
Traffic Engineering Accident Analysis System
Strip Analysis Report**

Acc No	Crash ID	Milepost	Date	Accident Type	Total Damage	Injuries				Condition			Road		Trfc Ctl	
						F	A	B	C	R	L	W	Ch	Ci	Dv	Op
Unit	2 : 1	Alchl/Drgs:	0	Speed:	60 MPH	Dir:	E	Veh Mnvr/Ped Actn:				4	Obj Strk:			
Unit	3 : 4	Alchl/Drgs:	0	Speed:	60 MPH	Dir:	E	Veh Mnvr/Ped Actn:				1	Obj Strk:			
463	102751751	25.638	12/21/2009 09:15	SIDESWIPE, SAME DIRECTION	\$ 1500	0	0	0	0	1	1	2	3	0	0	
Unit	1 : 14	Alchl/Drgs:	0	Speed:	50 MPH	Dir:	E	Veh Mnvr/Ped Actn:				5	Obj Strk:			
Unit	2 : 1	Alchl/Drgs:	0	Speed:	55 MPH	Dir:	E	Veh Mnvr/Ped Actn:				4	Obj Strk:			
464	102751856	25.638	12/23/2009 09:30	SIDESWIPE, SAME DIRECTION	\$ 2000	0	0	0	0	1	1	1	7	0	0	
Unit	1 : 14	Alchl/Drgs:	0	Speed:	55 MPH	Dir:	E	Veh Mnvr/Ped Actn:				4	Obj Strk:			
Unit	2 : 10	Alchl/Drgs:	0	Speed:	55 MPH	Dir:	E	Veh Mnvr/Ped Actn:				4	Obj Strk:			
465	102875197	25.638	05/28/2010 16:30	REAR END, SLOW OR STOP	\$ 1100	0	0	0	0	1	1	1	1	0	0	
Unit	1 : 1	Alchl/Drgs:	0	Speed:	15 MPH	Dir:	W	Veh Mnvr/Ped Actn:				4	Obj Strk:			
Unit	2 : 4	Alchl/Drgs:	0	Speed:	15 MPH	Dir:	W	Veh Mnvr/Ped Actn:				1	Obj Strk:			
466	103479415	25.638	06/19/2012 13:00	MOVABLE OBJECT	\$ 200	0	0	0	0	1	1	1	3	0	0	
Unit	1 : 5	Alchl/Drgs:	0	Speed:	60 MPH	Dir:	E	Veh Mnvr/Ped Actn:				4	Obj Strk: 64			
467	103479425	25.638	06/19/2012 13:00	MOVABLE OBJECT	\$ 600	0	0	0	0	1	1	1	3	0	0	
Unit	1 : 1	Alchl/Drgs:	0	Speed:	60 MPH	Dir:	E	Veh Mnvr/Ped Actn:				4	Obj Strk: 64			
468	103479435	25.638	06/19/2012 13:00	MOVABLE OBJECT	\$ 1500	0	0	0	0	1	1	1	3	0	0	
Unit	1 : 1	Alchl/Drgs:	0	Speed:	60 MPH	Dir:	E	Veh Mnvr/Ped Actn:				4	Obj Strk: 64			
469	102773600	25.738	01/20/2010 17:34	SIDESWIPE, SAME DIRECTION	\$ 1500	0	0	0	0	1	2	1	1	0	0	
Unit	1 : 1	Alchl/Drgs:	0	Speed:	60 MPH	Dir:	E	Veh Mnvr/Ped Actn:				5	Obj Strk:			
Unit	2 : 1	Alchl/Drgs:	0	Speed:	60 MPH	Dir:	E	Veh Mnvr/Ped Actn:				4	Obj Strk:			
470	102901155	25.840	06/25/2010 18:00	REAR END, SLOW OR STOP	\$ 1050	0	0	0	0	1	1	1	1	0	0	
Unit	1 : 4	Alchl/Drgs:	0	Speed:	40 MPH	Dir:	E	Veh Mnvr/Ped Actn:				4	Obj Strk:			
Unit	2 : 1	Alchl/Drgs:	0	Speed:	40 MPH	Dir:	E	Veh Mnvr/Ped Actn:				11	Obj Strk:			
471	103496496	25.870	07/13/2012 13:45	REAR END, SLOW OR STOP	\$ 2500	0	0	0	0	1	1	2	1	0	0	
Unit	1 : 4	Alchl/Drgs:	0	Speed:	60 MPH	Dir:	W	Veh Mnvr/Ped Actn:				4	Obj Strk:			
Unit	2 : 1	Alchl/Drgs:	0	Speed:	60 MPH	Dir:	W	Veh Mnvr/Ped Actn:				1	Obj Strk:			

**North Carolina Department of Transportation
Traffic Engineering Accident Analysis System
Strip Analysis Report**

Acc No	Crash ID	Milepost	Date	Accident Type	Total Damage	Injuries				Condition			Road		Trfc Ctl	
						F	A	B	C	R	L	W	Ch	Ci	Dv	Op
472	102852621	25.920	04/30/2010 18:14	REAR END, SLOW OR STOP	\$ 5500	0	0	0	0	1	1	1	1	0	0	
Unit	1 : 1	Alchl/Drgs:	0	Speed: 55 MPH Dir: W		Veh Mnvr/Ped Actn: 4				Obj Strk:						
Unit	2 : 1	Alchl/Drgs:	0	Speed: 35 MPH Dir: W		Veh Mnvr/Ped Actn: 11				Obj Strk:						
473	103507715	25.920	07/27/2012 16:54	REAR END, SLOW OR STOP	\$ 1500	0	0	0	0	1	1	1	1	0	0	
Unit	1 : 1	Alchl/Drgs:	0	Speed: 60 MPH Dir: N		Veh Mnvr/Ped Actn: 4				Obj Strk:						
Unit	2 : 1	Alchl/Drgs:	0	Speed: 45 MPH Dir: N		Veh Mnvr/Ped Actn: 11				Obj Strk:						
474	103370062	25.938	02/04/2012 21:28	FIXED OBJECT	\$ 1000	0	0	0	1	2	5	2	1	0	0	
Unit	1 : 1	Alchl/Drgs:	0	Speed: 60 MPH Dir: N		Veh Mnvr/Ped Actn: 15				Obj Strk: 44						
475	102676042	26.100	09/18/2009 21:16	SIDESWIPE, SAME DIRECTION	\$ 7400	0	0	0	1	2	5	2	1	0	0	
Unit	1 : 14	Alchl/Drgs:	0	Speed: 55 MPH Dir: W		Veh Mnvr/Ped Actn: 4				Obj Strk:						
Unit	2 : 1	Alchl/Drgs:	0	Speed: 60 MPH Dir: W		Veh Mnvr/Ped Actn: 4				Obj Strk: 42						
476	102917767	26.120	07/20/2010 14:15	SIDESWIPE, SAME DIRECTION	\$ 3500	0	0	0	0	1	1	1	3	0	0	
Unit	1 : 5	Alchl/Drgs:	0	Speed: 15 MPH Dir: E		Veh Mnvr/Ped Actn: 5				Obj Strk:						
Unit	2 : 3	Alchl/Drgs:	0	Speed: 15 MPH Dir: E		Veh Mnvr/Ped Actn: 4				Obj Strk:						
477	102961196	26.120	09/11/2010 11:30	REAR END, SLOW OR STOP	\$ 14500	0	0	0	0	2	1	3	3	0	0	
Unit	1 : 4	Alchl/Drgs:	0	Speed: 65 MPH Dir: W		Veh Mnvr/Ped Actn: 4				Obj Strk:						
Unit	2 : 5	Alchl/Drgs:	0	Speed: 0 MPH Dir: W		Veh Mnvr/Ped Actn: 1				Obj Strk:						
Unit	3 : 4	Alchl/Drgs:	0	Speed: 5 MPH Dir: W		Veh Mnvr/Ped Actn: 4				Obj Strk:						
478	102902166	26.138	07/01/2010 12:49	REAR END, SLOW OR STOP	\$ 1500	0	0	0	0	1	1	1	1	0	0	
Unit	1 : 1	Alchl/Drgs:	0	Speed: 45 MPH Dir: W		Veh Mnvr/Ped Actn: 4				Obj Strk:						
Unit	2 : 1	Alchl/Drgs:	0	Speed: 45 MPH Dir: W		Veh Mnvr/Ped Actn: 11				Obj Strk:						
479	102929244	26.138	08/04/2010 17:09	OTHER NON-COLLISION	\$ 8000	0	0	0	0	1	1	1	1	0	0	
Unit	1 : 4	Alchl/Drgs:	0	Speed: 55 MPH Dir: W		Veh Mnvr/Ped Actn: 4				Obj Strk:						
480	102991639	26.138	10/21/2010 20:36	REAR END, SLOW OR STOP	\$ 1500	0	0	0	0	1	5	1	1	0	0	
Unit	1 : 2	Alchl/Drgs:	0	Speed: 45 MPH Dir: W		Veh Mnvr/Ped Actn: 4				Obj Strk:						
Unit	2 : 1	Alchl/Drgs:	0	Speed: 40 MPH Dir: W		Veh Mnvr/Ped Actn: 4				Obj Strk:						
481	103000588	26.138	10/31/2010 19:32	PARKED MOTOR VEHICLE	\$ 3500	0	0	0	0	1	5	1	3	0	0	
Unit	1 : 5	Alchl/Drgs:	0	Speed: 60 MPH Dir: E		Veh Mnvr/Ped Actn: 4				Obj Strk: 20						

**North Carolina Department of Transportation
Traffic Engineering Accident Analysis System
Strip Analysis Report**

Acc No	Crash ID	Milepost	Date	Accident Type	Total Damage	Injuries				Condition			Road		Trfc Ctl	
						F	A	B	C	R	L	W	Ch	Ci	Dv	Op
Unit	2 : 1	Alchl/Drgs:	7	Speed:	0 MPH	Dir:	E	Veh Mnvr/Ped Actn:				2	Obj Strk:		20	
482	103275600	26.138	10/16/2011 11:44	REAR END, SLOW OR STOP	\$ 5600	0	0	0	0	1	1	1	1	0	0	
Unit	1 : 4	Alchl/Drgs:	0	Speed:	50 MPH	Dir:	E	Veh Mnvr/Ped Actn:				11	Obj Strk:			
Unit	2 : 1	Alchl/Drgs:	0	Speed:	50 MPH	Dir:	E	Veh Mnvr/Ped Actn:				11	Obj Strk:			
Unit	3 : 1	Alchl/Drgs:	0	Speed:	50 MPH	Dir:	E	Veh Mnvr/Ped Actn:				4	Obj Strk:			
483	102993149	26.220	10/22/2010 16:34	REAR END, SLOW OR STOP	\$ 7300	0	0	0	0	1	1	1	1	0	0	
Unit	1 : 4	Alchl/Drgs:	0	Speed:	40 MPH	Dir:	W	Veh Mnvr/Ped Actn:				4	Obj Strk:			
Unit	2 : 4	Alchl/Drgs:	0	Speed:	40 MPH	Dir:	W	Veh Mnvr/Ped Actn:				1	Obj Strk:			
484	103236853	26.220	08/27/2011 10:43	OVERTURN/ROLLOVER	\$ 4000	0	0	2	0	1	1	1	3	0	0	
Unit	1 : 4	Alchl/Drgs:	7	Speed:	60 MPH	Dir:	W	Veh Mnvr/Ped Actn:				4	Obj Strk:			
485	103284684	26.220	10/23/2011 11:50	REAR END, SLOW OR STOP	\$ 2500	0	0	0	0	1	1	1	1	0	0	
Unit	1 : 1	Alchl/Drgs:	0	Speed:	60 MPH	Dir:	W	Veh Mnvr/Ped Actn:				4	Obj Strk:			
Unit	2 : 1	Alchl/Drgs:	0	Speed:	50 MPH	Dir:	W	Veh Mnvr/Ped Actn:				11	Obj Strk:			
486	102809194	26.259	03/05/2010 12:25	SIDESWIPE, SAME DIRECTION	\$ 2400	0	0	0	0	1	1	1	1	0	0	
Unit	1 : 2	Alchl/Drgs:	0	Speed:	60 MPH	Dir:	E	Veh Mnvr/Ped Actn:				4	Obj Strk:			
Unit	2 : 5	Alchl/Drgs:	0	Speed:	60 MPH	Dir:	E	Veh Mnvr/Ped Actn:				4	Obj Strk:			
487	102852842	26.259	04/30/2010 21:30	REAR END, SLOW OR STOP	\$ 15000	0	0	0	0	1	5	1	1	0	0	
Unit	1 : 1	Alchl/Drgs:	0	Speed:	45 MPH	Dir:	N	Veh Mnvr/Ped Actn:				4	Obj Strk:			
Unit	2 : 1	Alchl/Drgs:	0	Speed:	0 MPH	Dir:	N	Veh Mnvr/Ped Actn:				1	Obj Strk:			
Unit	3 : 1	Alchl/Drgs:	0	Speed:	0 MPH	Dir:	N	Veh Mnvr/Ped Actn:				1	Obj Strk:			
Unit	4 : 2	Alchl/Drgs:	0	Speed:	0 MPH	Dir:	N	Veh Mnvr/Ped Actn:				1	Obj Strk:			
488	102999724	26.259	10/31/2010 14:17	REAR END, SLOW OR STOP	\$ 4900	0	0	0	0	1	1	1	1	0	0	
Unit	1 : 1	Alchl/Drgs:	0	Speed:	25 MPH	Dir:	W	Veh Mnvr/Ped Actn:				4	Obj Strk:			
Unit	2 : 1	Alchl/Drgs:	0	Speed:	25 MPH	Dir:	W	Veh Mnvr/Ped Actn:				11	Obj Strk:			
489	103501965	26.259	07/20/2012 20:30	FIXED OBJECT	\$ 9800	0	0	0	1	1	1	1	3	0	0	
Unit	1 : 4	Alchl/Drgs:	0	Speed:	70 MPH	Dir:	W	Veh Mnvr/Ped Actn:				4	Obj Strk:		44	
490	102748635	26.270	12/14/2009 10:00	OVERTURN/ROLLOVER	\$ 3500	0	0	1	0	1	1	2	3	0	0	
Unit	1 : 1	Alchl/Drgs:	0	Speed:	60 MPH	Dir:	W	Veh Mnvr/Ped Actn:				4	Obj Strk:			

**North Carolina Department of Transportation
Traffic Engineering Accident Analysis System
Strip Analysis Report**

Acc No	Crash ID	Milepost	Date	Accident Type	Total Damage	Injuries				Condition			Road		Trfc Ctl	
						F	A	B	C	R	L	W	Ch	Ci	Dv	Op
491	102952802	26.420	09/02/2010 16:57	REAR END, SLOW OR STOP	\$ 3500	0	0	0	0	1	1	1	3	0	0	
Unit	1 : 2	Alchl/Drgs:	0	Speed: 45 MPH Dir: W		Veh Mnvr/Ped Actn:				4	Obj Strk:					
Unit	2 : 4	Alchl/Drgs:	0	Speed: 5 MPH Dir: W		Veh Mnvr/Ped Actn:				4	Obj Strk:					
492	103486743	26.420	06/30/2012 13:39	SIDESWIPE, SAME DIRECTION	\$ 2200	0	0	0	0	1	1	1	3	0	0	
Unit	1 : 1	Alchl/Drgs:	0	Speed: 60 MPH Dir: W		Veh Mnvr/Ped Actn:				4	Obj Strk:					
Unit	2 : 5	Alchl/Drgs:	0	Speed: 60 MPH Dir: W		Veh Mnvr/Ped Actn:				4	Obj Strk:					
493	102994771	26.454	10/21/2010 13:04	REAR END, SLOW OR STOP	\$ 8300	0	0	1	4	1	1	1	5	0	0	
Unit	1 : 4	Alchl/Drgs:	0	Speed: 60 MPH Dir: S		Veh Mnvr/Ped Actn:				4	Obj Strk:					
Unit	2 : 1	Alchl/Drgs:	0	Speed: 55 MPH Dir: S		Veh Mnvr/Ped Actn:				1	Obj Strk:					
494	103406570	26.520	03/17/2012 23:15	FIXED OBJECT	\$ 200	0	0	1	0	1	5	1	3	0	0	
Unit	1 : 20	Alchl/Drgs:	0	Speed: 120 MPH Dir: W		Veh Mnvr/Ped Actn:				4	Obj Strk:		42			
495	103410339	26.520	03/24/2012 18:10	SIDESWIPE, SAME DIRECTION	\$ 1600	0	0	0	0	1	1	2	1	0	0	
Unit	1 : 1	Alchl/Drgs:	0	Speed: 65 MPH Dir: S		Veh Mnvr/Ped Actn:				16	Obj Strk:					
Unit	2 : 8	Alchl/Drgs:	0	Speed: 60 MPH Dir: S		Veh Mnvr/Ped Actn:				16	Obj Strk:					
496	102732537	26.620	12/01/2009 20:23	ANIMAL	\$ 1000	0	0	0	0	1	5	1	1	0	0	
Unit	1 : 4	Alchl/Drgs:	0	Speed: 60 MPH Dir: W		Veh Mnvr/Ped Actn:				4	Obj Strk:		17			
497	102851549	26.620	04/29/2010 12:40	REAR END, SLOW OR STOP	\$ 4700	0	0	0	1	1	1	1	7	0	0	
Unit	1 : 1	Alchl/Drgs:	0	Speed: 60 MPH Dir: NW		Veh Mnvr/Ped Actn:				4	Obj Strk:					
Unit	2 : 1	Alchl/Drgs:	0	Speed: 60 MPH Dir: NW		Veh Mnvr/Ped Actn:				11	Obj Strk:					
498	103419784	26.620	04/04/2012 15:35	REAR END, SLOW OR STOP	\$ 1700	0	0	0	0	2	1	2	3	0	0	
Unit	1 : 1	Alchl/Drgs:	0	Speed: 60 MPH Dir: W		Veh Mnvr/Ped Actn:				4	Obj Strk:					
Unit	2 : 4	Alchl/Drgs:	0	Speed: 60 MPH Dir: W		Veh Mnvr/Ped Actn:				11	Obj Strk:					
499	102645182	26.659	08/01/2009 00:42	OTHER COLLISION WITH VEHICLE	\$ 8000	0	0	2	0	1	5	1	1	0	0	
Unit	1 : 4	Alchl/Drgs:	1	Speed: 60 MPH Dir: W		Veh Mnvr/Ped Actn:				4	Obj Strk:					
Unit	2 : 20	Alchl/Drgs:	0	Speed: 60 MPH Dir: W		Veh Mnvr/Ped Actn:				4	Obj Strk:					
500	102738888	26.670	11/30/2009 01:33	FIXED OBJECT	\$ 9000	0	1	0	0	2	1	2	8	0	0	
Unit	1 : 4	Alchl/Drgs:	0	Speed: 85 MPH Dir: N		Veh Mnvr/Ped Actn:				4	Obj Strk:		33			

**North Carolina Department of Transportation
Traffic Engineering Accident Analysis System
Strip Analysis Report**

Acc No	Crash ID	Milepost	Date	Accident Type	Total Damage	Injuries				Condition			Road		Trfc Ctl	
						F	A	B	C	R	L	W	Ch	Ci	Dv	Op
501	103489396	26.670	06/28/2012 06:40	SIDESWIPE, SAME DIRECTION	\$ 2200	0	0	0	0	1	1	1	3	0	0	
Unit	1 : 14	Alchl/Drgs:	0	Speed: 60 MPH Dir: SE		Veh Mnvr/Ped Actn:				15	Obj Strk:					
Unit	2 : 2	Alchl/Drgs:	0	Speed: 60 MPH Dir: SE		Veh Mnvr/Ped Actn:				4	Obj Strk:					
502	103001279	26.759	11/01/2010 12:18	FIXED OBJECT	\$ 1500	0	0	0	0	1	1	1	1	0	0	
Unit	1 : 1	Alchl/Drgs:	0	Speed: 90 MPH Dir: N		Veh Mnvr/Ped Actn:				4	Obj Strk: 59					
503	103213393	26.820	07/28/2011 21:55	REAR END, SLOW OR STOP	\$ 4700	0	0	0	4	1	5	1	3	0	0	
Unit	1 : 1	Alchl/Drgs:	0	Speed: 50 MPH Dir: N		Veh Mnvr/Ped Actn:				4	Obj Strk:					
Unit	2 : 1	Alchl/Drgs:	0	Speed: 50 MPH Dir: N		Veh Mnvr/Ped Actn:				11	Obj Strk:					
504	102751883	26.920	12/23/2009 09:45	REAR END, SLOW OR STOP	\$ 500	0	0	0	1	1	1	1	3	0	0	
Unit	1 : 14	Alchl/Drgs:	0	Speed: 60 MPH Dir: E		Veh Mnvr/Ped Actn:				4	Obj Strk:					
Unit	2 : 1	Alchl/Drgs:	0	Speed: 60 MPH Dir: E		Veh Mnvr/Ped Actn:				11	Obj Strk:					
505	102680429	27.020	09/10/2009 09:25	MOVABLE OBJECT	\$ 300	0	0	0	0	1	1	2	3	0	0	
Unit	1 : 1	Alchl/Drgs:	0	Speed: 60 MPH Dir: E		Veh Mnvr/Ped Actn:				4	Obj Strk: 18					
506	102986559	27.020	10/15/2010 14:48	REAR END, SLOW OR STOP	\$ 2000	0	0	0	0	1	1	1	3	0	0	
Unit	1 : 1	Alchl/Drgs:	0	Speed: 60 MPH Dir: W		Veh Mnvr/Ped Actn:				11	Obj Strk:					
Unit	2 : 1	Alchl/Drgs:	0	Speed: 60 MPH Dir: W		Veh Mnvr/Ped Actn:				4	Obj Strk:					
507	102991490	27.020	10/21/2010 13:00	REAR END, SLOW OR STOP	\$ 24000	0	0	0	1	1	1	1	1	0	0	
Unit	1 : 14	Alchl/Drgs:	0	Speed: 60 MPH Dir: E		Veh Mnvr/Ped Actn:				11	Obj Strk:					
Unit	2 : 10	Alchl/Drgs:	0	Speed: 60 MPH Dir: E		Veh Mnvr/Ped Actn:				11	Obj Strk:					
Unit	3 : 10	Alchl/Drgs:	0	Speed: 60 MPH Dir: E		Veh Mnvr/Ped Actn:				11	Obj Strk:					
508	103024027	27.020	11/21/2010 11:03	OVERTURN/ROLLOVER	\$ 8500	0	1	0	0	1	1	1	3	0	0	
Unit	1 : 20	Alchl/Drgs:	0	Speed: 60 MPH Dir: NW		Veh Mnvr/Ped Actn:				4	Obj Strk:					
Unit	2 : 20	Alchl/Drgs:	0	Speed: 35 MPH Dir: NW		Veh Mnvr/Ped Actn:				11	Obj Strk:					
509	103185788	27.020	06/25/2011 07:05	SIDESWIPE, SAME DIRECTION	\$ 11100	1	0	0	1	1	1	2	1	0	0	
Unit	1 : 1	Alchl/Drgs:	0	Speed: 65 MPH Dir: W		Veh Mnvr/Ped Actn:				4	Obj Strk:					
Unit	2 : 1	Alchl/Drgs:	0	Speed: 65 MPH Dir: W		Veh Mnvr/Ped Actn:				4	Obj Strk: 59					
510	103254546	27.052	09/07/2011 13:55	REAR END, SLOW OR STOP	\$ 20000	0	0	1	3	1	1	2	3	0	0	
Unit	1 : 3	Alchl/Drgs:	0	Speed: 60 MPH Dir: W		Veh Mnvr/Ped Actn:				4	Obj Strk:					

**North Carolina Department of Transportation
Traffic Engineering Accident Analysis System
Strip Analysis Report**

Acc No	Crash ID	Milepost	Date	Accident Type	Total Damage	Injuries				Condition			Road		Trfc Ctl	
						F	A	B	C	R	L	W	Ch	Ci	Dv	Op
Unit	2 : 10	Alchl/Drgs:	0	Speed:	35 MPH	Dir:	W	Veh Mnvr/Ped Actn:				11	Obj Strk:			
511	103256261	27.120	08/24/2011 17:49	REAR END, SLOW OR STOP	\$ 2500	0	0	0	0	1	1	1	1	0	0	
Unit	1 : 1	Alchl/Drgs:	0	Speed:	50 MPH	Dir:	E	Veh Mnvr/Ped Actn:				4	Obj Strk:			
Unit	2 : 1	Alchl/Drgs:	0	Speed:	45 MPH	Dir:	E	Veh Mnvr/Ped Actn:				4	Obj Strk:			
512	103189004	27.138	06/28/2011 22:26	SIDESWIPE, SAME DIRECTION	\$ 5000	0	0	0	0	1	5	1	1	0	0	
Unit	1 : 14	Alchl/Drgs:	7	Speed:	65 MPH	Dir:	W	Veh Mnvr/Ped Actn:				4	Obj Strk:			
Unit	2 : 1	Alchl/Drgs:	0	Speed:	65 MPH	Dir:	W	Veh Mnvr/Ped Actn:				4	Obj Strk: 42			
513	102706306	27.220	10/24/2009 13:23	SIDESWIPE, SAME DIRECTION	\$ 6000	0	0	0	0	1	1	1	3	0	0	
Unit	1 : 1	Alchl/Drgs:	0	Speed:	60 MPH	Dir:	NW	Veh Mnvr/Ped Actn:				4	Obj Strk: 59			
Unit	2 : 4	Alchl/Drgs:	0	Speed:	60 MPH	Dir:	NW	Veh Mnvr/Ped Actn:				5	Obj Strk: 59			
514	102964464	27.220	09/17/2010 21:51	REAR END, SLOW OR STOP	\$ 2000	0	0	0	0	1	5	1	3	0	0	
Unit	1 : 3	Alchl/Drgs:	0	Speed:	0 MPH	Dir:	N	Veh Mnvr/Ped Actn:				4	Obj Strk:			
Unit	2 : 2	Alchl/Drgs:	0	Speed:	10 MPH	Dir:	N	Veh Mnvr/Ped Actn:				1	Obj Strk:			
515	103291052	27.220	10/28/2011 14:43	REAR END, SLOW OR STOP	\$ 550	0	0	0	0	2	1	2	3	0	0	
Unit	1 : 1	Alchl/Drgs:	0	Speed:	35 MPH	Dir:	W	Veh Mnvr/Ped Actn:				4	Obj Strk:			
Unit	2 : 1	Alchl/Drgs:	0	Speed:	35 MPH	Dir:	W	Veh Mnvr/Ped Actn:				1	Obj Strk:			
516	103208163	27.240	07/23/2011 12:58	REAR END, SLOW OR STOP	\$ 12000	0	0	1	0	1	1	1	3	0	0	
Unit	1 : 4	Alchl/Drgs:	0	Speed:	60 MPH	Dir:	W	Veh Mnvr/Ped Actn:				4	Obj Strk:			
Unit	2 : 4	Alchl/Drgs:	0	Speed:	60 MPH	Dir:	W	Veh Mnvr/Ped Actn:				1	Obj Strk:			
Unit	3 : 2	Alchl/Drgs:	0	Speed:	60 MPH	Dir:	W	Veh Mnvr/Ped Actn:				1	Obj Strk:			
517	102696600	27.259	10/04/2009 08:33	OTHER COLLISION WITH VEHICLE	\$ 4000	0	0	0	0	1	1	1	1	0	0	
Unit	1 : 14	Alchl/Drgs:	0	Speed:	60 MPH	Dir:	W	Veh Mnvr/Ped Actn:				4	Obj Strk:			
Unit	2 : 2	Alchl/Drgs:	0	Speed:	60 MPH	Dir:	E	Veh Mnvr/Ped Actn:				4	Obj Strk: 18			
518	102756952	27.259	12/29/2009 12:48	MOVABLE OBJECT	\$ 1200	0	0	0	0	1	1	1	1	0	0	
Unit	1 : 1	Alchl/Drgs:	0	Speed:	60 MPH	Dir:	E	Veh Mnvr/Ped Actn:				4	Obj Strk:			
Unit	2 : 32	Alchl/Drgs:	7	Speed:	60 MPH	Dir:	W	Veh Mnvr/Ped Actn:				16	Obj Strk:			
519	103008576	27.259	10/31/2010 14:26	REAR END, SLOW OR STOP	\$ 4300	0	0	0	0	1	1	1	1	4	0	
Unit	1 : 4	Alchl/Drgs:	0	Speed:	60 MPH	Dir:	W	Veh Mnvr/Ped Actn:				11	Obj Strk:			
Unit	2 : 4	Alchl/Drgs:	0	Speed:	65 MPH	Dir:	W	Veh Mnvr/Ped Actn:				4	Obj Strk:			

**North Carolina Department of Transportation
Traffic Engineering Accident Analysis System
Strip Analysis Report**

Acc No	Crash ID	Milepost	Date	Accident Type	Total Damage	Injuries				Condition			Road		Trfc Ctl	
						F	A	B	C	R	L	W	Ch	Ci	Dv	Op
520	103019583	27.259	11/21/2010 15:21	REAR END, SLOW OR STOP	\$ 7000	0	0	0	0	1	1	1	3	2	0	
Unit	1 : 4	Alchl/Drugs:	0	Speed:	60 MPH Dir: W	Veh Mnvr/Ped Actn:				4	Obj Strk:					
Unit	2 : 4	Alchl/Drugs:	0	Speed:	60 MPH Dir: W	Veh Mnvr/Ped Actn:				4	Obj Strk:		42			
521	103088682	27.259	02/11/2011 18:34	ANIMAL	\$ 4500	0	0	0	0	1	5	1	3	0	0	
Unit	1 : 1	Alchl/Drugs:	0	Speed:	60 MPH Dir: E	Veh Mnvr/Ped Actn:				4	Obj Strk:		17			
522	103481671	27.259	06/22/2012 18:06	REAR END, SLOW OR STOP	\$ 5500	0	0	0	0	1	1	2	3	0	0	
Unit	1 : 2	Alchl/Drugs:	0	Speed:	60 MPH Dir: W	Veh Mnvr/Ped Actn:				4	Obj Strk:					
Unit	2 : 4	Alchl/Drugs:	0	Speed:	60 MPH Dir: W	Veh Mnvr/Ped Actn:				1	Obj Strk:					
Unit	3 : 2	Alchl/Drugs:	0	Speed:	60 MPH Dir: W	Veh Mnvr/Ped Actn:				1	Obj Strk:					
523	102879897	27.280	06/05/2010 13:35	REAR END, SLOW OR STOP	\$ 3500	0	0	0	0	1	1	2	3	0	0	
Unit	1 : 4	Alchl/Drugs:	0	Speed:	45 MPH Dir: S	Veh Mnvr/Ped Actn:				4	Obj Strk:					
Unit	2 : 1	Alchl/Drugs:	0	Speed:	0 MPH Dir: S	Veh Mnvr/Ped Actn:				1	Obj Strk:					
524	102964528	27.320	09/17/2010 23:44	REAR END, SLOW OR STOP	\$ 1200	0	0	0	1	1	5	1	3	0	0	
Unit	1 : 2	Alchl/Drugs:	0	Speed:	60 MPH Dir: N	Veh Mnvr/Ped Actn:				4	Obj Strk:					
Unit	2 : 1	Alchl/Drugs:	0	Speed:	25 MPH Dir: N	Veh Mnvr/Ped Actn:				11	Obj Strk:					
525	103191238	27.320	06/21/2011 11:35	SIDESWIPE, SAME DIRECTION	\$ 13700	0	0	0	0	1	1	1	3	0	0	
Unit	1 : 14	Alchl/Drugs:	0	Speed:	60 MPH Dir: S	Veh Mnvr/Ped Actn:				4	Obj Strk:					
Unit	2 : 4	Alchl/Drugs:	0	Speed:	70 MPH Dir: S	Veh Mnvr/Ped Actn:				4	Obj Strk:		44			
526	103247642	27.320	09/09/2011 13:40	FIXED OBJECT	\$ 12000	0	0	0	1	1	1	1	3	0	0	
Unit	1 : 4	Alchl/Drugs:	3	Speed:	60 MPH Dir: W	Veh Mnvr/Ped Actn:				4	Obj Strk:		56			
527	103255321	27.320	09/20/2011 09:25	SIDESWIPE, SAME DIRECTION	\$ 4500	0	0	0	0	2	1	3	3	0	0	
Unit	1 : 1	Alchl/Drugs:	0	Speed:	60 MPH Dir: W	Veh Mnvr/Ped Actn:				5	Obj Strk:					
Unit	2 : 2	Alchl/Drugs:	0	Speed:	60 MPH Dir: W	Veh Mnvr/Ped Actn:				4	Obj Strk:					
528	103419777	27.320	04/04/2012 08:45	MOVABLE OBJECT	\$ 1000	0	0	0	0	1	1	1	3	0	0	
Unit	1 : 4	Alchl/Drugs:	0	Speed:	60 MPH Dir: W	Veh Mnvr/Ped Actn:				4	Obj Strk:		18			
529	103496731	27.320	07/14/2012 04:41	ANIMAL	\$ 1200	0	0	0	0	2	5	3	1	0	0	
Unit	1 : 1	Alchl/Drugs:	0	Speed:	60 MPH Dir: W	Veh Mnvr/Ped Actn:				4	Obj Strk:		17			

**North Carolina Department of Transportation
Traffic Engineering Accident Analysis System
Strip Analysis Report**

Acc No	Crash ID	Milepost	Date	Accident Type	Total Damage	Injuries				Condition			Road		Trfc Ctl	
						F	A	B	C	R	L	W	Ch	Ci	Dv	Op
530	102700919	27.403	10/09/2009 15:44	REAR END, SLOW OR STOP	\$ 8200	0	0	1	3	1	1	1	3	0	0	
Unit	1 : 2	Alchl/Drugs:	0	Speed:	0 MPH Dir: E	Veh Mnvr/Ped Actn:				1	Obj Strk:					
Unit	2 : 2	Alchl/Drugs:	0	Speed:	50 MPH Dir: E	Veh Mnvr/Ped Actn:				4	Obj Strk:					
Unit	3 : 4	Alchl/Drugs:	0	Speed:	50 MPH Dir: E	Veh Mnvr/Ped Actn:				4	Obj Strk:					
Unit	4 : 1	Alchl/Drugs:	0	Speed:	40 MPH Dir: E	Veh Mnvr/Ped Actn:				1	Obj Strk:					
Unit	5 : 2	Alchl/Drugs:	0	Speed:	35 MPH Dir: E	Veh Mnvr/Ped Actn:				6	Obj Strk:					

531	102986582	27.459	10/15/2010 14:45	REAR END, SLOW OR STOP	\$ 2000	0	0	0	0	1	1	1	3	0	0	
Unit	1 : 1	Alchl/Drugs:	0	Speed:	60 MPH Dir: W	Veh Mnvr/Ped Actn:				4	Obj Strk:					
Unit	2 : 4	Alchl/Drugs:	0	Speed:	60 MPH Dir: W	Veh Mnvr/Ped Actn:				11	Obj Strk:					

532	103112407	27.459	03/10/2011 09:14	SIDESWIPE, SAME DIRECTION	\$ 1450	0	0	0	0	1	1	2	3	0	0	
Unit	1 : 14	Alchl/Drugs:	0	Speed:	55 MPH Dir: W	Veh Mnvr/Ped Actn:				4	Obj Strk:					
Unit	2 : 10	Alchl/Drugs:	0	Speed:	60 MPH Dir: W	Veh Mnvr/Ped Actn:				5	Obj Strk:					

533	103254282	27.520	09/15/2011 10:11	MOVABLE OBJECT	\$ 800	0	0	0	0	1	1	1	1	0	0	
Unit	1 : 5	Alchl/Drugs:	0	Speed:	60 MPH Dir: S	Veh Mnvr/Ped Actn:				4	Obj Strk: 18					

534	103496491	27.520	07/12/2012 11:54	OTHER COLLISION WITH VEHICLE	\$ 1100	0	0	0	0	2	1	3	3	0	0	
Unit	1 : 1	Alchl/Drugs:	0	Speed:	70 MPH Dir: E	Veh Mnvr/Ped Actn:				5	Obj Strk:					
Unit	2 : 2	Alchl/Drugs:	0	Speed:	60 MPH Dir: E	Veh Mnvr/Ped Actn:				4	Obj Strk:					

535	103279862	27.552	10/19/2011 11:54	REAR END, SLOW OR STOP	\$ 26000	0	0	0	3	2	1	3	1	0	0	
Unit	1 : 12	Alchl/Drugs:	0	Speed:	55 MPH Dir: E	Veh Mnvr/Ped Actn:				4	Obj Strk:					
Unit	2 : 4	Alchl/Drugs:	0	Speed:	55 MPH Dir: E	Veh Mnvr/Ped Actn:				11	Obj Strk:					
Unit	3 : 2	Alchl/Drugs:	0	Speed:	55 MPH Dir: E	Veh Mnvr/Ped Actn:				11	Obj Strk:					

536	102724420	27.559	11/19/2009 06:49	FIXED OBJECT	\$ 1500	0	0	0	0	2	3	2	1	0	0	
Unit	1 : 2	Alchl/Drugs:	0	Speed:	65 MPH Dir: W	Veh Mnvr/Ped Actn:				4	Obj Strk: 59					

537	103294669	27.560	10/21/2011 15:53	REAR END, SLOW OR STOP	\$ 1500	0	0	0	0	1	1	1	1	0	0	
Unit	1 : 4	Alchl/Drugs:	0	Speed:	60 MPH Dir: W	Veh Mnvr/Ped Actn:				4	Obj Strk:					
Unit	2 : 5	Alchl/Drugs:	0	Speed:	60 MPH Dir: W	Veh Mnvr/Ped Actn:				4	Obj Strk:					
Unit	3 : 1	Alchl/Drugs:	0	Speed:	65 MPH Dir: W	Veh Mnvr/Ped Actn:				4	Obj Strk:					

538	103207541	27.620	07/02/2011 14:40	RAN OFF ROAD - RIGHT	\$ 3000	0	0	0	0	1	1	1	3	0	0	
Unit	1 : 4	Alchl/Drugs:	0	Speed:	55 MPH Dir: E	Veh Mnvr/Ped Actn:				4	Obj Strk: 41					

**North Carolina Department of Transportation
Traffic Engineering Accident Analysis System
Strip Analysis Report**

Acc No	Crash ID	Milepost	Date	Accident Type	Total Damage	Injuries				Condition			Road		Trfc Ctl		
						F	A	B	C	R	L	W	Ch	Ci	Dv	Op	
539	102747225	27.652	11/23/2009 00:50	FIXED OBJECT	\$ 1200	0	0	0	0	1	5	1	1	1	0		
Unit	1 : 4	Alchl/Drugs:	0	Speed: 550 MPH	Dir: E	Veh Mnvr/Ped Actn:				4	Obj Strk:		44				
540	102897719	27.659	06/25/2010 15:55	REAR END, SLOW OR STOP	\$ 5000	0	0	0	0	1	1	2	3	0	0		
Unit	1 : 1	Alchl/Drugs:	0	Speed: 40 MPH	Dir: NW	Veh Mnvr/Ped Actn:				1	Obj Strk:						
Unit	2 : 1	Alchl/Drugs:	0	Speed: 40 MPH	Dir: NW	Veh Mnvr/Ped Actn:				4	Obj Strk:						
541	102936321	27.759	08/12/2010 14:30	REAR END, SLOW OR STOP	\$ 5000	0	0	1	1	1	1	1	3	0	0		
Unit	1 : 2	Alchl/Drugs:	0	Speed: 45 MPH	Dir: E	Veh Mnvr/Ped Actn:				4	Obj Strk:						
Unit	2 : 4	Alchl/Drugs:	0	Speed: 45 MPH	Dir: E	Veh Mnvr/Ped Actn:				11	Obj Strk:						
542	102964051	27.759	09/17/2010 19:29	REAR END, SLOW OR STOP	\$ 6000	0	0	0	0	1	2	1	3	0	0		
Unit	1 : 1	Alchl/Drugs:	0	Speed: 20 MPH	Dir: W	Veh Mnvr/Ped Actn:				4	Obj Strk:						
Unit	2 : 4	Alchl/Drugs:	0	Speed: 10 MPH	Dir: W	Veh Mnvr/Ped Actn:				11	Obj Strk:						
543	103175916	27.759	06/11/2011 14:54	REAR END, SLOW OR STOP	\$ 8000	0	0	0	0	1	1	1	3	0	0		
Unit	1 : 2	Alchl/Drugs:	0	Speed: 60 MPH	Dir: W	Veh Mnvr/Ped Actn:				4	Obj Strk:						
Unit	2 : 3	Alchl/Drugs:	0	Speed: 0 MPH	Dir: W	Veh Mnvr/Ped Actn:				4	Obj Strk:						
Unit	3 : 3	Alchl/Drugs:	0	Speed: 0 MPH	Dir: W	Veh Mnvr/Ped Actn:				4	Obj Strk:						
544	102766983	27.859	01/14/2010 08:33	OTHER NON-COLLISION	\$ 6000	0	0	0	0	1	1	1	1	0	0		
Unit	1 : 2	Alchl/Drugs:	0	Speed: 60 MPH	Dir: W	Veh Mnvr/Ped Actn:				4	Obj Strk:		42				
545	102986986	27.859	10/15/2010 15:44	REAR END, SLOW OR STOP	\$ 9300	0	0	0	0	1	1	1	3	0	0		
Unit	1 : 1	Alchl/Drugs:	0	Speed: 45 MPH	Dir: W	Veh Mnvr/Ped Actn:				4	Obj Strk:						
Unit	2 : 3	Alchl/Drugs:	0	Speed: 45 MPH	Dir: W	Veh Mnvr/Ped Actn:				11	Obj Strk:						
Unit	3 : 1	Alchl/Drugs:	0	Speed: 45 MPH	Dir: W	Veh Mnvr/Ped Actn:				1	Obj Strk:						
546	102991605	27.859	10/19/2010 17:25	SIDESWIPE, SAME DIRECTION	\$ 1800	0	0	0	0	1	1	1	1	0	0		
Unit	1 : 2	Alchl/Drugs:	0	Speed: 60 MPH	Dir: NW	Veh Mnvr/Ped Actn:				4	Obj Strk:						
Unit	2 : 1	Alchl/Drugs:	7	Speed: 60 MPH	Dir: NW	Veh Mnvr/Ped Actn:				5	Obj Strk:						
547	103151709	27.859	05/06/2011 18:35	FIXED OBJECT	\$ 5300	0	0	0	0	1	1	1	1	0	0		
Unit	1 : 1	Alchl/Drugs:	0	Speed: 70 MPH	Dir: NW	Veh Mnvr/Ped Actn:				4	Obj Strk:		42				
548	103204650	27.859	07/19/2011 18:49	REAR END, SLOW OR STOP	\$ 5900	0	0	0	0	1	1	1	3	0	0		
Unit	1 : 4	Alchl/Drugs:	0	Speed: 40 MPH	Dir: W	Veh Mnvr/Ped Actn:				4	Obj Strk:						

**North Carolina Department of Transportation
Traffic Engineering Accident Analysis System
Strip Analysis Report**

Acc No	Crash ID	Milepost	Date	Accident Type	Total Damage	Injuries				Condition			Road		Trfc Ctl		
						F	A	B	C	R	L	W	Ch	Ci	Dv	Op	
Unit	2 : 4	Alchl/Drgs:	0	Speed:	40 MPH	Dir:	W	Veh Mnvr/Ped Actn:				11	Obj Strk:				
549	103011491	27.959	11/12/2010 15:30	REAR END, SLOW OR STOP	\$ 13750			0	0	0	0	1	1	1	3	0	0
Unit	1 : 1	Alchl/Drgs:	0	Speed:	55 MPH	Dir:	W	Veh Mnvr/Ped Actn:				4	Obj Strk:				
Unit	2 : 4	Alchl/Drgs:	0	Speed:	55 MPH	Dir:	W	Veh Mnvr/Ped Actn:				11	Obj Strk:				
Unit	3 : 3	Alchl/Drgs:	0	Speed:	55 MPH	Dir:	W	Veh Mnvr/Ped Actn:				11	Obj Strk:				
550	103019464	27.959	11/20/2010 19:50	REAR END, SLOW OR STOP	\$ 13000			0	0	0	0	1	5	1	1	0	0
Unit	1 : 2	Alchl/Drgs:	7	Speed:	60 MPH	Dir:	N	Veh Mnvr/Ped Actn:				4	Obj Strk:				
Unit	2 : 1	Alchl/Drgs:	0	Speed:	60 MPH	Dir:	N	Veh Mnvr/Ped Actn:				11	Obj Strk:				
Unit	3 : 1	Alchl/Drgs:	0	Speed:	60 MPH	Dir:	N	Veh Mnvr/Ped Actn:				4	Obj Strk:				
551	103191545	27.959	07/02/2011 14:12	REAR END, SLOW OR STOP	\$ 12250			0	0	0	0	1	1	1	2	0	0
Unit	1 : 2	Alchl/Drgs:	0	Speed:	0 MPH	Dir:	W	Veh Mnvr/Ped Actn:				11	Obj Strk:				
Unit	2 : 3	Alchl/Drgs:	0	Speed:	10 MPH	Dir:	W	Veh Mnvr/Ped Actn:				11	Obj Strk:				
Unit	3 : 4	Alchl/Drgs:	0	Speed:	10 MPH	Dir:	W	Veh Mnvr/Ped Actn:				11	Obj Strk:				
Unit	4 : 1	Alchl/Drgs:	7	Speed:	30 MPH	Dir:	W	Veh Mnvr/Ped Actn:				4	Obj Strk:				
552	102709693	28.059	10/18/2009 15:38	REAR END, SLOW OR STOP	\$ 5000			0	0	0	2	1	1	1	1	0	
Unit	1 : 1	Alchl/Drgs:	0	Speed:	60 MPH	Dir:	E	Veh Mnvr/Ped Actn:				4	Obj Strk:				
Unit	2 : 4	Alchl/Drgs:	0	Speed:	60 MPH	Dir:	E	Veh Mnvr/Ped Actn:				11	Obj Strk:				
553	102930377	28.059	08/04/2010 18:09	REAR END, SLOW OR STOP	\$ 300			0	0	0	0	1	1	1	1	0	0
Unit	1 : 2	Alchl/Drgs:	0	Speed:	15 MPH	Dir:	NW	Veh Mnvr/Ped Actn:				4	Obj Strk:				
Unit	2 : 2	Alchl/Drgs:	0	Speed:	10 MPH	Dir:	NW	Veh Mnvr/Ped Actn:				11	Obj Strk:				
554	103011474	28.059	11/12/2010 15:30	SIDESWIPE, SAME DIRECTION	\$ 500			0	0	0	0	1	1	1	3	0	0
Unit	1 : 1	Alchl/Drgs:	0	Speed:	30 MPH	Dir:	W	Veh Mnvr/Ped Actn:				5	Obj Strk:				
Unit	2 : 2	Alchl/Drgs:	0	Speed:	45 MPH	Dir:	W	Veh Mnvr/Ped Actn:				4	Obj Strk:				
555	103195068	28.059	07/02/2011 14:13	REAR END, SLOW OR STOP	\$ 16500			0	0	1	1	1	1	1	3	0	0
Unit	1 : 1	Alchl/Drgs:	0	Speed:	60 MPH	Dir:	N	Veh Mnvr/Ped Actn:				4	Obj Strk:				
Unit	2 : 2	Alchl/Drgs:	0	Speed:	0 MPH	Dir:	N	Veh Mnvr/Ped Actn:				1	Obj Strk:				
556	103275860	28.059	10/16/2011 16:20	REAR END, SLOW OR STOP	\$ 3000			0	0	0	0	1	1	1	3	0	0
Unit	1 : 1	Alchl/Drgs:	0	Speed:	60 MPH	Dir:	W	Veh Mnvr/Ped Actn:				4	Obj Strk:				
Unit	2 : 1	Alchl/Drgs:	0	Speed:	60 MPH	Dir:	W	Veh Mnvr/Ped Actn:				11	Obj Strk:				

**North Carolina Department of Transportation
Traffic Engineering Accident Analysis System
Strip Analysis Report**

Acc No	Crash ID	Milepost	Date	Accident Type	Total Damage	Injuries				Condition			Road		Trfc Ctl	
						F	A	B	C	R	L	W	Ch	Ci	Dv	Op
557	103495560	28.059	07/11/2012 16:53	REAR END, SLOW OR STOP	\$ 9000	0	0	0	0	2	1	3	1	0	0	
Unit	1 : 1	Alchl/Drgs:	0	Speed: 40 MPH Dir: W		Veh Mnvr/Ped Actn: 4				Obj Strk:						
Unit	2 : 4	Alchl/Drgs:	0	Speed: 45 MPH Dir: W		Veh Mnvr/Ped Actn: 11				Obj Strk:						
558	102722432	28.159	11/15/2009 01:44	OTHER COLLISION WITH VEHICLE	\$ 2000	0	0	0	0	1	5	1	1	0	1	1
Unit	1 : 1	Alchl/Drgs:	7	Speed: 15 MPH Dir: NW		Veh Mnvr/Ped Actn: 12				Obj Strk:						
Unit	2 : 1	Alchl/Drgs:	0	Speed: 50 MPH Dir: N		Veh Mnvr/Ped Actn: 4				Obj Strk:						
559	102741040	28.159	12/08/2009 13:40	REAR END, SLOW OR STOP	\$ 6000	0	0	0	1	2	1	3	3	0	0	
Unit	1 : 1	Alchl/Drgs:	1	Speed: 35 MPH Dir: S		Veh Mnvr/Ped Actn: 4				Obj Strk:						
Unit	2 : 1	Alchl/Drgs:	0	Speed: 10 MPH Dir: S		Veh Mnvr/Ped Actn: 11				Obj Strk:						
560	102898196	28.159	06/25/2010 16:25	REAR END, SLOW OR STOP	\$ 7000	0	0	0	1	1	1	2	1	0	0	
Unit	1 : 1	Alchl/Drgs:	0	Speed: 45 MPH Dir: W		Veh Mnvr/Ped Actn: 11				Obj Strk:						
Unit	2 : 2	Alchl/Drgs:	0	Speed: 45 MPH Dir: W		Veh Mnvr/Ped Actn: 4				Obj Strk:						
561	102980919	28.159	10/08/2010 19:58	SIDESWIPE, SAME DIRECTION	\$ 4000	0	0	0	0	1	2	1	1	0	0	
Unit	1 : 1	Alchl/Drgs:	0	Speed: 5 MPH Dir: N		Veh Mnvr/Ped Actn: 5				Obj Strk:						
Unit	2 : 14	Alchl/Drgs:	0	Speed: 5 MPH Dir: N		Veh Mnvr/Ped Actn: 4				Obj Strk:						
562	103061891	28.159	01/08/2011 10:00	REAR END, SLOW OR STOP	\$ 6550	0	0	0	0	5	1	4	1	0	0	
Unit	1 : 14	Alchl/Drgs:	0	Speed: 45 MPH Dir: W		Veh Mnvr/Ped Actn: 11				Obj Strk:						
Unit	2 : 1	Alchl/Drgs:	0	Speed: 45 MPH Dir: W		Veh Mnvr/Ped Actn: 4				Obj Strk:						
563	103101188	28.159	03/01/2011 16:09	SIDESWIPE, SAME DIRECTION	\$ 1000	0	0	0	0	1	1	1	3	0	0	
Unit	1 : 1	Alchl/Drgs:	0	Speed: 60 MPH Dir: W		Veh Mnvr/Ped Actn: 5				Obj Strk:						
Unit	2 : 4	Alchl/Drgs:	0	Speed: 60 MPH Dir: W		Veh Mnvr/Ped Actn: 4				Obj Strk:						
564	103175907	28.159	06/11/2011 16:22	REAR END, SLOW OR STOP	\$ 800	0	0	0	0	1	1	2	3	0	0	
Unit	1 : 1	Alchl/Drgs:	7	Speed: 15 MPH Dir: W		Veh Mnvr/Ped Actn: 4				Obj Strk:						
Unit	2 : 5	Alchl/Drgs:	0	Speed: 15 MPH Dir: W		Veh Mnvr/Ped Actn: 1				Obj Strk:						
Unit	3 : 4	Alchl/Drgs:	0	Speed: 15 MPH Dir: W		Veh Mnvr/Ped Actn: 1				Obj Strk:						
565	103275706	28.159	10/16/2011 02:06	ANIMAL	\$ 2000	0	0	0	0	1	5	1	1	0	0	
Unit	1 : 2	Alchl/Drgs:	0	Speed: 60 MPH Dir: SE		Veh Mnvr/Ped Actn: 4				Obj Strk:		17				

**North Carolina Department of Transportation
Traffic Engineering Accident Analysis System
Strip Analysis Report**

Acc No	Crash ID	Milepost	Date	Accident Type	Total Damage	Injuries				Condition			Road		Trfc Ctl	
						F	A	B	C	R	L	W	Ch	Ci	Dv	Op
566	103025967	28.273	11/21/2010 11:10	REAR END, SLOW OR STOP	\$ 4500	0	0	0	0	1	1	2	3	0	0	
Unit	1 : 1	Alchl/Drgs:	0	Speed: 60 MPH Dir: W		Veh Mnvr/Ped Actn: 4				Obj Strk:						
Unit	2 : 1	Alchl/Drgs:	0	Speed: 20 MPH Dir: W		Veh Mnvr/Ped Actn: 11				Obj Strk:						

567	102980930	28.320	10/08/2010 21:37	REAR END, SLOW OR STOP	\$ 6500	0	0	0	0	1	5	1	1	0	0	
Unit	1 : 1	Alchl/Drgs:	0	Speed: 60 MPH Dir: N		Veh Mnvr/Ped Actn: 4				Obj Strk:						
Unit	2 : 1	Alchl/Drgs:	0	Speed: 60 MPH Dir: N		Veh Mnvr/Ped Actn: 1				Obj Strk:						
Unit	3 : 1	Alchl/Drgs:	0	Speed: 60 MPH Dir: N		Veh Mnvr/Ped Actn: 1				Obj Strk:						

568	102693397	28.359	10/07/2009 20:50	REAR END, SLOW OR STOP	\$ 3700	0	0	0	0	1	5	1	1	0	0	
Unit	1 : 4	Alchl/Drgs:	0	Speed: 50 MPH Dir: E		Veh Mnvr/Ped Actn: 4				Obj Strk:						
Unit	2 : 1	Alchl/Drgs:	0	Speed: 50 MPH Dir: E		Veh Mnvr/Ped Actn: 11				Obj Strk:						

569	102980998	28.359	10/08/2010 16:32	REAR END, SLOW OR STOP	\$ 2000	0	0	0	0	1	1	1	1	0	0	
Unit	1 : 2	Alchl/Drgs:	0	Speed: 50 MPH Dir: W		Veh Mnvr/Ped Actn: 4				Obj Strk:						
Unit	2 : 1	Alchl/Drgs:	0	Speed: 10 MPH Dir: W		Veh Mnvr/Ped Actn: 4				Obj Strk:						

570	103214068	28.359	07/11/2011 07:51	SIDESWIPE, SAME DIRECTION	\$ 600	0	0	0	0	1	1	1	1	0	0	
Unit	1 : 14	Alchl/Drgs:	0	Speed: 50 MPH Dir: SE		Veh Mnvr/Ped Actn: 4				Obj Strk:						
Unit	2 : 1	Alchl/Drgs:	0	Speed: 50 MPH Dir: SE		Veh Mnvr/Ped Actn: 5				Obj Strk:						

571	103488137	28.359	06/28/2012 22:19	SIDESWIPE, SAME DIRECTION	\$ 1300	0	0	0	0	1	5	1	1	0	0	
Unit	1 : 1	Alchl/Drgs:	0	Speed: 20 MPH Dir: S		Veh Mnvr/Ped Actn: 5				Obj Strk:						
Unit	2 : 25	Alchl/Drgs:	0	Speed: 15 MPH Dir: S		Veh Mnvr/Ped Actn: 4				Obj Strk:						

572	103488211	28.586	06/30/2012 15:05	REAR END, SLOW OR STOP	\$ 4500	0	0	0	0	1	1	1	1	0	0	
Unit	1 : 4	Alchl/Drgs:	0	Speed: 60 MPH Dir: W		Veh Mnvr/Ped Actn: 4				Obj Strk:						
Unit	2 : 5	Alchl/Drgs:	0	Speed: 60 MPH Dir: W		Veh Mnvr/Ped Actn: 11				Obj Strk:						

573	103387477	29.046	02/24/2012 13:30	FIXED OBJECT	\$ 2000	0	0	0	1	2	1	2	1	0	0	
Unit	1 : 1	Alchl/Drgs:	0	Speed: 45 MPH Dir: E		Veh Mnvr/Ped Actn: 4				Obj Strk: 42						

574	103165066	29.186	05/25/2011 23:50	REAR END, SLOW OR STOP	\$ 8500	0	0	0	1	1	5	1	1	0	0	
Unit	1 : 14	Alchl/Drgs:	0	Speed: 45 MPH Dir: N		Veh Mnvr/Ped Actn: 4				Obj Strk:						
Unit	2 : 1	Alchl/Drgs:	0	Speed: 65 MPH Dir: N		Veh Mnvr/Ped Actn: 4				Obj Strk:						

**North Carolina Department of Transportation
Traffic Engineering Accident Analysis System
Strip Analysis Report**

Acc No	Crash ID	Milepost	Date	Accident Type	Total Damage	Injuries				Condition			Road		Trfc Ctl	
						F	A	B	C	R	L	W	Ch	Ci	Dv	Op
575	102958671	29.207	09/11/2010 13:50	REAR END, SLOW OR STOP	\$ 15800	0	0	0	1	2	1	3	1	0	0	
Unit	1 : 2	Alchl/Drgs:	0	Speed:	20 MPH Dir: W	Veh Mnvr/Ped Actn:				11	Obj Strk:		17			
Unit	2 : 1	Alchl/Drgs:	0	Speed:	60 MPH Dir: W	Veh Mnvr/Ped Actn:				4	Obj Strk:					
Unit	3 : 4	Alchl/Drgs:	0	Speed:	60 MPH Dir: W	Veh Mnvr/Ped Actn:				4	Obj Strk:					
576	102715246	29.214	10/23/2009 19:26	REAR END, SLOW OR STOP	\$ 13000	0	0	0	0	2	5	3	1	0		
Unit	1 : 4	Alchl/Drgs:	0	Speed:	55 MPH Dir: NW	Veh Mnvr/Ped Actn:				4	Obj Strk:					
Unit	2 : 2	Alchl/Drgs:	1	Speed:	45 MPH Dir: NW	Veh Mnvr/Ped Actn:				11	Obj Strk:					
577	102851725	29.226	04/26/2010 20:15	SIDESWIPE, SAME DIRECTION	\$ 7000	0	0	0	0	1	5	2	1	0	0	
Unit	1 : 12	Alchl/Drgs:	7	Speed:	60 MPH Dir: E	Veh Mnvr/Ped Actn:				16	Obj Strk:					
Unit	2 : 4	Alchl/Drgs:	0	Speed:	50 MPH Dir: E	Veh Mnvr/Ped Actn:				4	Obj Strk:		44			
578	102702419	29.286	10/23/2009 16:03	REAR END, SLOW OR STOP	\$ 600	0	0	0	0	2	1	3	1	0	0	
Unit	1 : 1	Alchl/Drgs:	0	Speed:	60 MPH Dir: W	Veh Mnvr/Ped Actn:				11	Obj Strk:					
Unit	2 : 4	Alchl/Drgs:	0	Speed:	60 MPH Dir: W	Veh Mnvr/Ped Actn:				1	Obj Strk:					
579	102752304	29.286	12/21/2009 21:31	MOVABLE OBJECT	\$ 1000	0	0	0	0	2	5	2	3	0	0	
Unit	1 : 2	Alchl/Drgs:	0	Speed:	55 MPH Dir: SE	Veh Mnvr/Ped Actn:				4	Obj Strk:					
Unit	2 : 1	Alchl/Drgs:	0	Speed:	55 MPH Dir: SE	Veh Mnvr/Ped Actn:				4	Obj Strk:					
580	102788754	29.286	01/24/2010 08:30	SIDESWIPE, SAME DIRECTION	\$ 4000	0	0	0	1	2	1	3	1	0	0	
Unit	1 : 4	Alchl/Drgs:	0	Speed:	55 MPH Dir: W	Veh Mnvr/Ped Actn:				5	Obj Strk:					
Unit	2 : 32	Alchl/Drgs:	7	Speed:	45 MPH Dir: W	Veh Mnvr/Ped Actn:				4	Obj Strk:					
581	103446738	29.286	05/08/2012 12:45	REAR END, SLOW OR STOP	\$ 2850	0	0	0	0	1	1	1	1	0	0	
Unit	1 : 4	Alchl/Drgs:	0	Speed:	60 MPH Dir: E	Veh Mnvr/Ped Actn:				4	Obj Strk:					
Unit	2 : 1	Alchl/Drgs:	0	Speed:	60 MPH Dir: E	Veh Mnvr/Ped Actn:				4	Obj Strk:					
582	102658373	29.353	08/18/2009 22:01	REAR END, SLOW OR STOP	\$ 2200	0	0	0	1	1	5	1	1	0		
Unit	1 : 4	Alchl/Drgs:	0	Speed:	50 MPH Dir: E	Veh Mnvr/Ped Actn:				11	Obj Strk:					
Unit	2 : 1	Alchl/Drgs:	0	Speed:	65 MPH Dir: E	Veh Mnvr/Ped Actn:				4	Obj Strk:					
583	103319257	29.386	12/02/2011 18:10	REAR END, SLOW OR STOP	\$ 5500	0	0	0	0	1	5	1	7	0	0	
Unit	1 : 2	Alchl/Drgs:	7	Speed:	40 MPH Dir: SE	Veh Mnvr/Ped Actn:				4	Obj Strk:					
Unit	2 : 3	Alchl/Drgs:	0	Speed:	35 MPH Dir: SE	Veh Mnvr/Ped Actn:				5	Obj Strk:		42			

**North Carolina Department of Transportation
Traffic Engineering Accident Analysis System
Strip Analysis Report**

Acc No	Crash ID	Milepost	Date	Accident Type	Total Damage	Injuries				Condition			Road		Trfc Ctl	
						F	A	B	C	R	L	W	Ch	Ci	Dv	Op
584	103382395	29.476	02/20/2012 22:19	SIDESWIPE, SAME DIRECTION	\$ 16000	0	0	0	0	1	5	1	1	0	0	
Unit	1 : 14	Alchl/Drgs:	0	Speed: 60 MPH Dir: W		Veh Mnvr/Ped Actn:				5	Obj Strk:					
Unit	2 : 1	Alchl/Drgs:	0	Speed: 60 MPH Dir: W		Veh Mnvr/Ped Actn:				4	Obj Strk:		42			

585	102931874	29.586	08/08/2010 13:01	REAR END, SLOW OR STOP	\$ 4000	0	0	0	0	1	1	1	1	0	0	
Unit	1 : 4	Alchl/Drgs:	0	Speed: 0 MPH Dir: W		Veh Mnvr/Ped Actn:				1	Obj Strk:					
Unit	2 : 2	Alchl/Drgs:	0	Speed: 20 MPH Dir: W		Veh Mnvr/Ped Actn:				4	Obj Strk:					

586	103182009	29.586	06/19/2011 23:48	REAR END, SLOW OR STOP	\$ 15600	1	0	0	0	1	5	2	1	0	0	
Unit	1 : 14	Alchl/Drgs:	0	Speed: 60 MPH Dir: W		Veh Mnvr/Ped Actn:				4	Obj Strk:					
Unit	2 : 20	Alchl/Drgs:	1	Speed: 100 MPH Dir: W		Veh Mnvr/Ped Actn:				6	Obj Strk:					
Unit	3 : 5	Alchl/Drgs:	0	Speed: 60 MPH Dir: W		Veh Mnvr/Ped Actn:				4	Obj Strk:		14			

587	103191109	29.586	06/24/2011 05:03	MOVABLE OBJECT	\$ 800	0	0	0	0	1	5	1	1	2	0	
Unit	1 : 4	Alchl/Drgs:	0	Speed: 65 MPH Dir: NW		Veh Mnvr/Ped Actn:				4	Obj Strk:		18			

588	103327922	29.676	12/13/2011 10:16	REAR END, SLOW OR STOP	\$ 14000	0	0	0	0	1	1	1	1	0	0	
Unit	1 : 2	Alchl/Drgs:	0	Speed: 65 MPH Dir: E		Veh Mnvr/Ped Actn:				4	Obj Strk:					
Unit	2 : 2	Alchl/Drgs:	0	Speed: 70 MPH Dir: E		Veh Mnvr/Ped Actn:				4	Obj Strk:					

589	102679302	29.686	09/09/2009 06:05	REAR END, SLOW OR STOP	\$ 17000	0	0	1	0	1	5	2	1	0	0	
Unit	1 : 14	Alchl/Drgs:	0	Speed: 60 MPH Dir: W		Veh Mnvr/Ped Actn:				4	Obj Strk:					
Unit	2 : 4	Alchl/Drgs:	0	Speed: 30 MPH Dir: W		Veh Mnvr/Ped Actn:				4	Obj Strk:					

590	103446752	29.686	05/08/2012 10:40	REAR END, SLOW OR STOP	\$ 7150	0	0	0	1	1	1	1	1	0	0	
Unit	1 : 2	Alchl/Drgs:	0	Speed: 45 MPH Dir: W		Veh Mnvr/Ped Actn:				4	Obj Strk:					
Unit	2 : 5	Alchl/Drgs:	0	Speed: 60 MPH Dir: W		Veh Mnvr/Ped Actn:				4	Obj Strk:					

591	103443962	29.696	05/07/2012 09:42	SIDESWIPE, SAME DIRECTION	\$ 1200	0	0	0	0	1	1	1	1	0	0	
Unit	1 : 1	Alchl/Drgs:	0	Speed: 65 MPH Dir: NW		Veh Mnvr/Ped Actn:				4	Obj Strk:					
Unit	2 : 4	Alchl/Drgs:	0	Speed: 65 MPH Dir: NW		Veh Mnvr/Ped Actn:				5	Obj Strk:					

592	102863908	29.786	05/15/2010 06:58	SIDESWIPE, SAME DIRECTION	\$ 4300	0	0	0	0	1	3	1	1	0	0	
Unit	1 : 1	Alchl/Drgs:	0	Speed: 60 MPH Dir: N		Veh Mnvr/Ped Actn:				5	Obj Strk:					
Unit	2 : 4	Alchl/Drgs:	0	Speed: 60 MPH Dir: N		Veh Mnvr/Ped Actn:				4	Obj Strk:					

**North Carolina Department of Transportation
Traffic Engineering Accident Analysis System
Strip Analysis Report**

Acc No	Crash ID	Milepost	Date	Accident Type	Total Damage	Injuries				Condition			Road		Trfc Ctl	
						F	A	B	C	R	L	W	Ch	Ci	Dv	Op
593	103388068	29.786	02/25/2012 14:30	MOVABLE OBJECT	\$ 500	0	0	0	0	1	1	1	1	0	0	
Unit	1 : 1	Alchl/Drgs:	0	Speed:	55 MPH	Dir:	W	Veh Mnvr/Ped Actn:				4	Obj Strk:		18	
Unit	2 : 5	Alchl/Drgs:	0	Speed:	50 MPH	Dir:	W	Veh Mnvr/Ped Actn:				2	Obj Strk:			
594	102769803	29.824	01/17/2010 14:05	REAR END, SLOW OR STOP	\$ 11000	0	0	0	1	2	1	2	1	0	0	
Unit	1 : 1	Alchl/Drgs:	0	Speed:	0 MPH	Dir:	W	Veh Mnvr/Ped Actn:				1	Obj Strk:			
Unit	2 : 1	Alchl/Drgs:	0	Speed:	60 MPH	Dir:	W	Veh Mnvr/Ped Actn:				4	Obj Strk:			
595	103363756	29.867	01/27/2012 16:24	REAR END, SLOW OR STOP	\$ 1000	0	0	0	1	1	1	1	1	0	0	
Unit	1 : 4	Alchl/Drgs:	0	Speed:	65 MPH	Dir:	W	Veh Mnvr/Ped Actn:				4	Obj Strk:			
Unit	2 : 1	Alchl/Drgs:	0	Speed:	65 MPH	Dir:	W	Veh Mnvr/Ped Actn:				4	Obj Strk:			
596	103504879	29.886	07/25/2012 00:22	SIDESWIPE, SAME DIRECTION	\$ 8500	0	0	0	0	1	1	1	1	0	0	
Unit	1 : 10	Alchl/Drgs:	0	Speed:	65 MPH	Dir:	E	Veh Mnvr/Ped Actn:				5	Obj Strk:			
Unit	2 : 1	Alchl/Drgs:	0	Speed:	60 MPH	Dir:	E	Veh Mnvr/Ped Actn:				4	Obj Strk:		44	
597	103137826	29.896	04/18/2011 17:50	MOVABLE OBJECT	\$ 250	0	0	0	0	1	1	1	1	2	0	
Unit	1 : 4	Alchl/Drgs:	0	Speed:	60 MPH	Dir:	N	Veh Mnvr/Ped Actn:				4	Obj Strk:		18	
598	102695101	29.986	10/01/2009 21:54	SIDESWIPE, SAME DIRECTION	\$ 3800	0	0	0	0	1	4	1	5	0	10	1
Unit	1 : 1	Alchl/Drgs:	0	Speed:	55 MPH	Dir:	SE	Veh Mnvr/Ped Actn:				5	Obj Strk:			
Unit	2 : 3	Alchl/Drgs:	0	Speed:	55 MPH	Dir:	SE	Veh Mnvr/Ped Actn:				4	Obj Strk:			
599	102804230	29.996	02/28/2010 20:25	FIXED OBJECT	\$ 3800	0	0	0	0	1	5	1	1	0	0	
Unit	1 : 1	Alchl/Drgs:	1	Speed:	60 MPH	Dir:	E	Veh Mnvr/Ped Actn:				4	Obj Strk:		44	
600	103169286	30.067	05/29/2011 15:34	FIXED OBJECT	\$ 6500	0	0	0	0	1	1	1	1	0	0	
Unit	1 : 1	Alchl/Drgs:	0	Speed:	65 MPH	Dir:	N	Veh Mnvr/Ped Actn:				4	Obj Strk:		44	
Unit	2 : 32	Alchl/Drgs:	7	Speed:	65 MPH	Dir:	N	Veh Mnvr/Ped Actn:				5	Obj Strk:			
601	103311591	30.096	11/25/2011 13:15	ANIMAL	\$ 6000	0	0	0	0	1	1	1	1	0	0	
Unit	1 : 4	Alchl/Drgs:	0	Speed:	55 MPH	Dir:	SE	Veh Mnvr/Ped Actn:				4	Obj Strk:		17	
602	102895661	30.176	06/22/2010 16:20	SIDESWIPE, SAME DIRECTION	\$ 4300	0	0	0	0	1	1	1	1	0	0	
Unit	1 : 3	Alchl/Drgs:	0	Speed:	60 MPH	Dir:	W	Veh Mnvr/Ped Actn:				4	Obj Strk:			
Unit	2 : 1	Alchl/Drgs:	0	Speed:	60 MPH	Dir:	W	Veh Mnvr/Ped Actn:				5	Obj Strk:		42	

**North Carolina Department of Transportation
Traffic Engineering Accident Analysis System
Strip Analysis Report**

Acc No	Crash ID	Milepost	Date	Accident Type	Total Damage	Injuries				Condition			Road		Trfc Ctl	
						F	A	B	C	R	L	W	Ch	Ci	Dv	Op
603	103087764	30.186	02/09/2011 19:35	FIXED OBJECT	\$ 250	0	0	0	0	1	4	1	1	0	0	
Unit	1 : 1	Alchl/Drgs:	3	Speed:	60 MPH	Dir:	S	Veh Mnvr/Ped Actn:				4	Obj Strk:			
Unit	2 : 1	Alchl/Drgs:	0	Speed:	60 MPH	Dir:	S	Veh Mnvr/Ped Actn:				4	Obj Strk:		64	
604	103437449	30.186	04/29/2012 16:09	SIDESWIPE, SAME DIRECTION	\$ 14500	0	0	0	0	1	1	1	1	0	0	
Unit	1 : 1	Alchl/Drgs:	0	Speed:	80 MPH	Dir:	W	Veh Mnvr/Ped Actn:				5	Obj Strk:		44	
Unit	2 : 1	Alchl/Drgs:	0	Speed:	60 MPH	Dir:	W	Veh Mnvr/Ped Actn:				4	Obj Strk:		44	
605	103439542	30.186	05/01/2012 15:40	SIDESWIPE, SAME DIRECTION	\$ 5000	0	0	0	0	2	1	3	1	0	0	
Unit	1 : 1	Alchl/Drgs:	0	Speed:	65 MPH	Dir:	W	Veh Mnvr/Ped Actn:				4	Obj Strk:			
Unit	2 : 4	Alchl/Drgs:	0	Speed:	60 MPH	Dir:	W	Veh Mnvr/Ped Actn:				4	Obj Strk:			
606	103503856	30.196	07/23/2012 13:19	FIXED OBJECT	\$ 3400	0	0	0	1	1	1	2	1	0	0	
Unit	1 : 2	Alchl/Drgs:	0	Speed:	60 MPH	Dir:	NW	Veh Mnvr/Ped Actn:				4	Obj Strk:		44	
607	102908580	30.210	07/10/2010 04:25	FIXED OBJECT	\$ 903	0	0	1	0	1	5	1	1	0	0	
Unit	1 : 1	Alchl/Drgs:	0	Speed:	60 MPH	Dir:	W	Veh Mnvr/Ped Actn:				4	Obj Strk:		44	
608	103214926	30.296	07/30/2011 12:13	SIDESWIPE, SAME DIRECTION	\$ 39400	0	0	0	2	1	1	1	5	0	0	
Unit	1 : 4	Alchl/Drgs:	0	Speed:	60 MPH	Dir:	SE	Veh Mnvr/Ped Actn:				5	Obj Strk:		42	
Unit	2 : 4	Alchl/Drgs:	0	Speed:	60 MPH	Dir:	SE	Veh Mnvr/Ped Actn:				4	Obj Strk:		44	
Unit	3 : 2	Alchl/Drgs:	0	Speed:	60 MPH	Dir:	NW	Veh Mnvr/Ped Actn:				4	Obj Strk:		18	
609	102788203	30.467	02/11/2010 05:59	MOVABLE OBJECT	\$ 2000	0	0	1	0	1	5	7	1	6	0	
Unit	1 : 2	Alchl/Drgs:	0	Speed:	60 MPH	Dir:	W	Veh Mnvr/Ped Actn:				4	Obj Strk:		33	
610	102901423	30.467	06/30/2010 06:55	FIXED OBJECT	\$ 4000	0	0	0	0	1	3	1	1	0	0	
Unit	1 : 5	Alchl/Drgs:	0	Speed:	60 MPH	Dir:	W	Veh Mnvr/Ped Actn:				4	Obj Strk:		44	
611	103052575	30.467	12/27/2010 08:23	RAN OFF ROAD - RIGHT	\$ 1700	0	0	0	0	4	1	1	1	0	0	
Unit	1 : 1	Alchl/Drgs:	0	Speed:	60 MPH	Dir:	W	Veh Mnvr/Ped Actn:				4	Obj Strk:		38	
612	103052776	30.467	12/27/2010 09:20	RAN OFF ROAD - LEFT	\$ 1500	0	0	0	1	4	1	2	1	1	0	
Unit	1 : 5	Alchl/Drgs:	0	Speed:	45 MPH	Dir:	W	Veh Mnvr/Ped Actn:				4	Obj Strk:		18	
613	103487076	30.467	06/30/2012 13:30	REAR END, SLOW OR STOP	\$ 3000	0	0	0	0	1	1	1	1	0	0	
Unit	1 : 4	Alchl/Drgs:	0	Speed:	60 MPH	Dir:	W	Veh Mnvr/Ped Actn:				4	Obj Strk:			

**North Carolina Department of Transportation
Traffic Engineering Accident Analysis System
Strip Analysis Report**

Acc No	Crash ID	Milepost	Date	Accident Type	Total Damage	Injuries				Condition			Road		Trfc Ctl	
						F	A	B	C	R	L	W	Ch	Ci	Dv	Op
Unit	2 : 4	Alchl/Drgs:	0	Speed:	60 MPH	Dir:	W	Veh Mnvr/Ped Actn:				4	Obj Strk:			
614	102709818	30.486	10/18/2009 14:30	REAR END, SLOW OR STOP	\$ 2700	0	0	0	0	1	1	1	1	0	0	
Unit	1 : 4	Alchl/Drgs:	0	Speed:	60 MPH	Dir:	E	Veh Mnvr/Ped Actn:				4	Obj Strk:			
Unit	2 : 1	Alchl/Drgs:	0	Speed:	60 MPH	Dir:	E	Veh Mnvr/Ped Actn:				1	Obj Strk:			
615	103437439	30.486	04/18/2012 04:55	FIXED OBJECT	\$ 3000	0	0	0	0	2	5	3	1	0	0	
Unit	1 : 1	Alchl/Drgs:	7	Speed:	65 MPH	Dir:	W	Veh Mnvr/Ped Actn:				4	Obj Strk: 44			
616	103196332	30.496	07/08/2011 13:58	FIXED OBJECT	\$ 2750	0	0	0	0	2	1	3	1	0	0	
Unit	1 : 1	Alchl/Drgs:	0	Speed:	60 MPH	Dir:	E	Veh Mnvr/Ped Actn:				4	Obj Strk: 42			
617	103338865	30.540	12/17/2011 10:40	REAR END, SLOW OR STOP	\$ 4500	0	0	0	0	1	1	1	1	0	0	
Unit	1 : 2	Alchl/Drgs:	1	Speed:	65 MPH	Dir:	W	Veh Mnvr/Ped Actn:				4	Obj Strk:			
Unit	2 : 4	Alchl/Drgs:	0	Speed:	55 MPH	Dir:	W	Veh Mnvr/Ped Actn:				4	Obj Strk:			
618	103416523	30.576	04/02/2012 15:11	OTHER COLLISION WITH VEHICLE	\$ 2000	0	0	0	0	1	1	1	1	0	0	
Unit	1 : 14	Alchl/Drgs:	0	Speed:	60 MPH	Dir:	W	Veh Mnvr/Ped Actn:				4	Obj Strk:			
Unit	2 : 1	Alchl/Drgs:	0	Speed:	60 MPH	Dir:	W	Veh Mnvr/Ped Actn:				5	Obj Strk:			
619	103437361	30.586	04/29/2012 16:49	REAR END, SLOW OR STOP	\$ 4100	0	0	0	0	1	1	1	1	0	0	
Unit	1 : 4	Alchl/Drgs:	0	Speed:	65 MPH	Dir:	W	Veh Mnvr/Ped Actn:				1	Obj Strk:			
Unit	2 : 1	Alchl/Drgs:	0	Speed:	65 MPH	Dir:	W	Veh Mnvr/Ped Actn:				4	Obj Strk:			
620	102916838	30.596	07/16/2010 22:54	SIDESWIPE, SAME DIRECTION	\$ 4700	0	0	0	0	1	5	1	1	0	0	
Unit	1 : 4	Alchl/Drgs:	7	Speed:	80 MPH	Dir:	SE	Veh Mnvr/Ped Actn:				4	Obj Strk:			
Unit	2 : 1	Alchl/Drgs:	0	Speed:	55 MPH	Dir:	SE	Veh Mnvr/Ped Actn:				4	Obj Strk:			
621	102941559	30.626	08/17/2010 16:10	SIDESWIPE, SAME DIRECTION	\$ 7000	0	0	0	0	2	1	3	1	0	0	
Unit	1 : 1	Alchl/Drgs:	0	Speed:	60 MPH	Dir:	W	Veh Mnvr/Ped Actn:				5	Obj Strk: 44			
Unit	2 : 2	Alchl/Drgs:	0	Speed:	60 MPH	Dir:	W	Veh Mnvr/Ped Actn:				4	Obj Strk: 44			
622	102882876	30.640	06/09/2010 08:39	OVERTURN/ROLLOVER	\$ 4000	0	0	0	1	1	1	2	3	0	0	
Unit	1 : 4	Alchl/Drgs:	0	Speed:	60 MPH	Dir:	NW	Veh Mnvr/Ped Actn:				4	Obj Strk:			
623	102920329	30.740	07/25/2010 17:45	FIXED OBJECT	\$ 2200	0	0	0	0	2	1	3	1	0	0	
Unit	1 : 1	Alchl/Drgs:	0	Speed:	55 MPH	Dir:	E	Veh Mnvr/Ped Actn:				4	Obj Strk: 42			

**North Carolina Department of Transportation
Traffic Engineering Accident Analysis System
Strip Analysis Report**

Acc No	Crash ID	Milepost	Date	Accident Type	Total Damage	Injuries				Condition			Road		Trfc Ctl	
						F	A	B	C	R	L	W	Ch	Ci	Dv	Op
624	103403598	30.796	03/16/2012 19:14	FIXED OBJECT	\$ 2900	0	0	0	0	2	2	3	1	0	0	
Unit	1 : 1	Alchl/Drgs:	0	Speed: 60 MPH	Dir: W	Veh Mnvr/Ped Actn:				4	Obj Strk:		44			
625	103288098	30.967	10/28/2011 15:15	SIDESWIPE, SAME DIRECTION	\$ 27800	0	0	0	0	2	1	3	1	0	0	
Unit	1 : 4	Alchl/Drgs:	0	Speed: 70 MPH	Dir: W	Veh Mnvr/Ped Actn:				5	Obj Strk:		44			
Unit	2 : 1	Alchl/Drgs:	0	Speed: 60 MPH	Dir: W	Veh Mnvr/Ped Actn:				4	Obj Strk:		42			
Unit	3 : 4	Alchl/Drgs:	0	Speed: 60 MPH	Dir: W	Veh Mnvr/Ped Actn:				4	Obj Strk:					
626	102705479	30.986	10/12/2009 03:59	FIXED OBJECT	\$ 16800	0	0	0	1	1	5	1	1	0	10	1
Unit	1 : 1	Alchl/Drgs:	2	Speed: 65 MPH	Dir: NW	Veh Mnvr/Ped Actn:				4	Obj Strk:		44			
627	102783526	31.140	01/15/2010 21:10	FIXED OBJECT	\$ 12500	0	0	0	0	1	5	1	1	0		
Unit	1 : 1	Alchl/Drgs:	0	Speed: 60 MPH	Dir: W	Veh Mnvr/Ped Actn:				4	Obj Strk:		37			
628	103214577	31.167	07/30/2011 12:40	REAR END, SLOW OR STOP	\$ 10000	0	0	0	0	1	1	1	1	0	0	
Unit	1 : 5	Alchl/Drgs:	0	Speed: 35 MPH	Dir: W	Veh Mnvr/Ped Actn:				4	Obj Strk:					
Unit	2 : 2	Alchl/Drgs:	0	Speed: 5 MPH	Dir: W	Veh Mnvr/Ped Actn:				1	Obj Strk:					
629	103178059	31.186	06/11/2011 18:01	SIDESWIPE, SAME DIRECTION	\$ 1500	0	0	0	0	1	1	1	1	0	0	
Unit	1 : 4	Alchl/Drgs:	0	Speed: 60 MPH	Dir: E	Veh Mnvr/Ped Actn:				4	Obj Strk:					
Unit	2 : 1	Alchl/Drgs:	7	Speed: 60 MPH	Dir: E	Veh Mnvr/Ped Actn:				5	Obj Strk:					
630	103342509	31.296	12/31/2011 15:00	FIXED OBJECT	\$ 5300	0	0	0	2	1	5	1	1	0	0	
Unit	1 : 1	Alchl/Drgs:	0	Speed: 60 MPH	Dir: S	Veh Mnvr/Ped Actn:				4	Obj Strk:		42			
631	102994865	31.386	10/24/2010 23:30	REAR END, SLOW OR STOP	\$ 7000	0	0	0	2	1	5	1	1	0	0	
Unit	1 : 14	Alchl/Drgs:	0	Speed: 45 MPH	Dir: E	Veh Mnvr/Ped Actn:				11	Obj Strk:					
Unit	2 : 1	Alchl/Drgs:	0	Speed: 60 MPH	Dir: E	Veh Mnvr/Ped Actn:				11	Obj Strk:					
632	102821369	31.396	03/24/2010 12:15	SIDESWIPE, SAME DIRECTION	\$ 2700	0	0	0	0	1	5	1	1	0	0	
Unit	1 : 14	Alchl/Drgs:	0	Speed: 55 MPH	Dir: W	Veh Mnvr/Ped Actn:				4	Obj Strk:					
Unit	2 : 1	Alchl/Drgs:	0	Speed: 60 MPH	Dir: W	Veh Mnvr/Ped Actn:				5	Obj Strk:					
633	103175854	31.440	06/11/2011 12:46	FIXED OBJECT	\$ 1400	0	0	0	0	1	1	1	1	0	0	
Unit	1 : 1	Alchl/Drgs:	0	Speed: 65 MPH	Dir: W	Veh Mnvr/Ped Actn:				4	Obj Strk:		44			

**North Carolina Department of Transportation
Traffic Engineering Accident Analysis System
Strip Analysis Report**

Acc No	Crash ID	Milepost	Date	Accident Type	Total Damage	Injuries				Condition			Road		Trfc Ctl	
						F	A	B	C	R	L	W	Ch	Ci	Dv	Op
634	103329902	31.440	12/15/2011 14:12	ANIMAL	\$ 1400	0	0	0	0	1	1	1	1	0	0	
Unit	1 : 1	Alchl/Drgs:	0	Speed: 60 MPH	Dir: E	Veh Mnvr/Ped Actn:				4	Obj Strk:		17			
635	102694231	31.467	09/29/2009 16:09	SIDESWIPE, SAME DIRECTION	\$ 7600	0	1	0	0	1	1	1	1	0	0	
Unit	1 : 1	Alchl/Drgs:	7	Speed: 0 MPH	Dir: E	Veh Mnvr/Ped Actn:				3	Obj Strk:		20			
Unit	2 : 4	Alchl/Drgs:	0	Speed: 60 MPH	Dir: E	Veh Mnvr/Ped Actn:				15	Obj Strk:		14			
Unit	3 : 24	Alchl/Drgs:	0	Speed: 0 MPH	Dir:	Veh Mnvr/Ped Actn:					Obj Strk:		14			
636	103490750	31.821	07/05/2012 14:26	REAR END, SLOW OR STOP	\$ 2800	0	0	0	0	1	1	2	1	0	0	
Unit	1 : 1	Alchl/Drgs:	0	Speed: 60 MPH	Dir: NW	Veh Mnvr/Ped Actn:				4	Obj Strk:					
Unit	2 : 4	Alchl/Drgs:	0	Speed: 65 MPH	Dir: NW	Veh Mnvr/Ped Actn:				11	Obj Strk:					
637	102959839	31.832	09/13/2010 14:11	SIDESWIPE, SAME DIRECTION	\$ 1850	0	0	0	0	1	1	1	1	0	0	
Unit	1 : 2	Alchl/Drgs:	0	Speed: 60 MPH	Dir: W	Veh Mnvr/Ped Actn:				5	Obj Strk:					
Unit	2 : 1	Alchl/Drgs:	0	Speed: 60 MPH	Dir: W	Veh Mnvr/Ped Actn:				4	Obj Strk:					
638	103012561	31.840	10/24/2010 22:53	REAR END, SLOW OR STOP	\$ 157100	5	4	2	4	1	5	1	1	0	0	
Unit	1 : 14	Alchl/Drgs:	6	Speed: 70 MPH	Dir: SE	Veh Mnvr/Ped Actn:				4	Obj Strk:		44			
Unit	2 : 1	Alchl/Drgs:	0	Speed: 0 MPH	Dir: SE	Veh Mnvr/Ped Actn:				1	Obj Strk:		44			
Unit	3 : 4	Alchl/Drgs:	0	Speed: 0 MPH	Dir: SE	Veh Mnvr/Ped Actn:				1	Obj Strk:		44			
Unit	4 : 4	Alchl/Drgs:	0	Speed: 0 MPH	Dir: SE	Veh Mnvr/Ped Actn:				1	Obj Strk:					
Unit	5 : 1	Alchl/Drgs:	0	Speed: 0 MPH	Dir: SE	Veh Mnvr/Ped Actn:				1	Obj Strk:					
Unit	6 : 3	Alchl/Drgs:	0	Speed: 0 MPH	Dir: SE	Veh Mnvr/Ped Actn:				1	Obj Strk:					
Unit	7 : 1	Alchl/Drgs:	0	Speed: 0 MPH	Dir: SE	Veh Mnvr/Ped Actn:				1	Obj Strk:					
Unit	8 : 2	Alchl/Drgs:	0	Speed: 0 MPH	Dir: SE	Veh Mnvr/Ped Actn:				1	Obj Strk:					
Unit	9 : 14	Alchl/Drgs:	0	Speed: 0 MPH	Dir: SE	Veh Mnvr/Ped Actn:				1	Obj Strk:					
639	103130245	31.840	04/07/2011 06:28	SIDESWIPE, SAME DIRECTION	\$ 8000	0	0	0	0	1	3	1	1	0	0	
Unit	1 : 15	Alchl/Drgs:	0	Speed: 25 MPH	Dir: E	Veh Mnvr/Ped Actn:				4	Obj Strk:					
Unit	2 : 14	Alchl/Drgs:	0	Speed: 10 MPH	Dir: E	Veh Mnvr/Ped Actn:				4	Obj Strk:					
640	102891672	31.859	06/18/2010 17:30	SIDESWIPE, SAME DIRECTION	\$ 14700	0	0	0	0	1	1	1	1	0	0	
Unit	1 : 1	Alchl/Drgs:	1	Speed: 70 MPH	Dir: E	Veh Mnvr/Ped Actn:				4	Obj Strk:					
Unit	2 : 4	Alchl/Drgs:	0	Speed: 60 MPH	Dir: E	Veh Mnvr/Ped Actn:				4	Obj Strk:					
641	103491013	31.867	07/05/2012 14:35	FIXED OBJECT	\$ 2500	0	0	0	0	1	1	1	1	0	0	
Unit	1 : 2	Alchl/Drgs:	0	Speed: 60 MPH	Dir: W	Veh Mnvr/Ped Actn:				4	Obj Strk:		44			

**North Carolina Department of Transportation
Traffic Engineering Accident Analysis System
Strip Analysis Report**

Acc No	Crash ID	Milepost	Date	Accident Type	Total Damage	Injuries				Condition			Road		Trfc Ctl	
						F	A	B	C	R	L	W	Ch	Ci	Dv	Op
642	102847555	31.940	04/23/2010 13:41	SIDESWIPE, SAME DIRECTION	\$ 3800	0	1	1	0	1	1	1	1	0	0	
Unit	1 : 20	Alchl/Drgs:	0	Speed: 55 MPH Dir: NW		Veh Mnvr/Ped Actn: 4				Obj Strk:						
Unit	2 : 20	Alchl/Drgs:	0	Speed: 40 MPH Dir: NW		Veh Mnvr/Ped Actn: 11				Obj Strk:						
643	103468825	31.967	06/06/2012 19:50	REAR END, SLOW OR STOP	\$ 2500	0	0	0	0	1	1	1	1	4	0	
Unit	1 : 4	Alchl/Drgs:	0	Speed: 55 MPH Dir: W		Veh Mnvr/Ped Actn: 4				Obj Strk:						
Unit	2 : 4	Alchl/Drgs:	0	Speed: 50 MPH Dir: W		Veh Mnvr/Ped Actn: 11				Obj Strk:						
644	103483074	31.967	06/25/2012 11:48	REAR END, SLOW OR STOP	\$ 6000	0	0	0	0	1	1	1	1	0	0	
Unit	1 : 4	Alchl/Drgs:	0	Speed: 60 MPH Dir: W		Veh Mnvr/Ped Actn: 11				Obj Strk:						
Unit	2 : 1	Alchl/Drgs:	0	Speed: 60 MPH Dir: W		Veh Mnvr/Ped Actn: 11				Obj Strk:						
645	102996145	32.067	10/24/2010 23:00	REAR END, SLOW OR STOP	\$ 5500	0	0	0	0	1	5	2	1	0	0	
Unit	1 : 1	Alchl/Drgs:	0	Speed: 15 MPH Dir: E		Veh Mnvr/Ped Actn: 4				Obj Strk:						
Unit	2 : 2	Alchl/Drgs:	0	Speed: 5 MPH Dir: E		Veh Mnvr/Ped Actn: 11				Obj Strk:						
646	103504546	32.067	07/23/2012 14:01	SIDESWIPE, SAME DIRECTION	\$ 3800	0	0	0	0	1	1	1	1	0	0	
Unit	1 : 1	Alchl/Drgs:	0	Speed: 10 MPH Dir: W		Veh Mnvr/Ped Actn: 11				Obj Strk:						
Unit	2 : 2	Alchl/Drgs:	0	Speed: 60 MPH Dir: W		Veh Mnvr/Ped Actn: 4				Obj Strk: 42						
647	102722835	32.086	10/29/2009 12:19	FIXED OBJECT	\$ 750	0	0	0	0	1	1	1	1	0	0	
Unit	1 : 2	Alchl/Drgs:	0	Speed: 60 MPH Dir: W		Veh Mnvr/Ped Actn: 4				Obj Strk: 44						
648	102753540	32.140	11/27/2009 18:00	SIDESWIPE, SAME DIRECTION	\$ 2000	0	0	0	0	1	5	1	1	0	0	
Unit	1 : 1	Alchl/Drgs:	0	Speed: 60 MPH Dir: E		Veh Mnvr/Ped Actn: 4				Obj Strk:						
Unit	2 : 1	Alchl/Drgs:	0	Speed: 60 MPH Dir: E		Veh Mnvr/Ped Actn: 4				Obj Strk:						
649	102677565	32.167	09/05/2009 20:19	FIXED OBJECT	\$ 4500	0	0	0	1	1	5	1	1	0	0	
Unit	1 : 1	Alchl/Drgs:	1	Speed: 75 MPH Dir: W		Veh Mnvr/Ped Actn: 4				Obj Strk: 42						
650	103344026	32.276	01/02/2012 20:21	REAR END, SLOW OR STOP	\$ 2500	0	0	0	0	5	5	4	1	0	0	
Unit	1 : 5	Alchl/Drgs:	0	Speed: 45 MPH Dir: S		Veh Mnvr/Ped Actn: 4				Obj Strk:						
Unit	2 : 4	Alchl/Drgs:	0	Speed: 30 MPH Dir: S		Veh Mnvr/Ped Actn: 4				Obj Strk:						
651	102751082	32.286	12/05/2009 18:22	ANIMAL	\$ 3000	0	0	0	0	1	5	2		0		
Unit	1 : 4	Alchl/Drgs:	0	Speed: 0 MPH Dir: W		Veh Mnvr/Ped Actn: 16				Obj Strk: 17						

**North Carolina Department of Transportation
Traffic Engineering Accident Analysis System
Strip Analysis Report**

Acc No	Crash ID	Milepost	Date	Accident Type	Total Damage	Injuries				Condition			Road		Trfc Ctl	
						F	A	B	C	R	L	W	Ch	Ci	Dv	Op
652	103012570	32.286	11/11/2010 11:29	SIDESWIPE, SAME DIRECTION	\$ 2000	0	0	0	0	1	1	1	1	0	0	
Unit	1 : 4	Alchl/Drgs:	0	Speed: 60 MPH Dir: E		Veh Mnvr/Ped Actn:				4	Obj Strk:		44			
Unit	2 : 4	Alchl/Drgs:	0	Speed: 50 MPH Dir: E		Veh Mnvr/Ped Actn:				5	Obj Strk:					
653	102720347	32.367	11/13/2009 19:13	REAR END, SLOW OR STOP	\$ 2000	0	0	0	0	1	5	1	1	0	0	
Unit	1 : 1	Alchl/Drgs:	0	Speed: 30 MPH Dir: E		Veh Mnvr/Ped Actn:				4	Obj Strk:					
Unit	2 : 1	Alchl/Drgs:	0	Speed: 60 MPH Dir: E		Veh Mnvr/Ped Actn:				4	Obj Strk:					
654	102808822	32.367	03/05/2010 21:13	REAR END, SLOW OR STOP	\$ 15700	0	0	0	1	1	5	1	1	0	0	
Unit	1 : 1	Alchl/Drgs:	0	Speed: 60 MPH Dir: E		Veh Mnvr/Ped Actn:				4	Obj Strk:					
Unit	2 : 4	Alchl/Drgs:	7	Speed: 75 MPH Dir: E		Veh Mnvr/Ped Actn:				4	Obj Strk:					
655	102928095	32.367	08/02/2010 14:53	SIDESWIPE, SAME DIRECTION	\$ 1500	0	0	0	0	1	1	1	5	0	0	
Unit	1 : 4	Alchl/Drgs:	0	Speed: 65 MPH Dir: N		Veh Mnvr/Ped Actn:				5	Obj Strk:					
Unit	2 : 4	Alchl/Drgs:	0	Speed: 65 MPH Dir: N		Veh Mnvr/Ped Actn:				4	Obj Strk:					
656	103129978	32.367	04/07/2011 05:36	FIXED OBJECT	\$ 16000	0	0	1	0	1	5	1	5	0	0	
Unit	1 : 4	Alchl/Drgs:	0	Speed: 80 MPH Dir: NW		Veh Mnvr/Ped Actn:				4	Obj Strk:		42			
657	103344949	32.367	01/02/2012 20:00	FIXED OBJECT	\$ 1300	0	0	0	0	4	5	4	1	0	0	
Unit	1 : 1	Alchl/Drgs:	7	Speed: 45 MPH Dir: S		Veh Mnvr/Ped Actn:				4	Obj Strk:		38			
658	103486791	32.367	06/29/2012 18:00	MOVABLE OBJECT	\$ 800	0	0	0	0	1	1	1	1	0	0	
Unit	1 : 4	Alchl/Drgs:	0	Speed: 60 MPH Dir: E		Veh Mnvr/Ped Actn:				4	Obj Strk:		18			
659	103458599	32.386	05/23/2012 09:05	FIXED OBJECT	\$ 3300	0	0	0	0	2	1	2	1	0	0	
Unit	1 : 4	Alchl/Drgs:	0	Speed: 50 MPH Dir: E		Veh Mnvr/Ped Actn:				4	Obj Strk:		42			
660	102914530	32.433	07/17/2010 12:54	REAR END, SLOW OR STOP	\$ 3850	0	0	0	0	2	1	2	1	0	0	
Unit	1 : 5	Alchl/Drgs:	0	Speed: 60 MPH Dir: E		Veh Mnvr/Ped Actn:				4	Obj Strk:					
Unit	2 : 1	Alchl/Drgs:	0	Speed: 60 MPH Dir: E		Veh Mnvr/Ped Actn:				11	Obj Strk:					
661	103076325	32.476	01/23/2011 18:25	REAR END, SLOW OR STOP	\$ 5000	0	0	0	0	1	5	1	1	0	0	
Unit	1 : 1	Alchl/Drgs:	0	Speed: 15 MPH Dir: E		Veh Mnvr/Ped Actn:				4	Obj Strk:					
Unit	2 : 1	Alchl/Drgs:	0	Speed: 50 MPH Dir: E		Veh Mnvr/Ped Actn:				4	Obj Strk:					

**North Carolina Department of Transportation
Traffic Engineering Accident Analysis System
Strip Analysis Report**

Acc No	Crash ID	Milepost	Date	Accident Type	Total Damage	Injuries				Condition			Road		Trfc Ctl	
						F	A	B	C	R	L	W	Ch	Ci	Dv	Op
662	103488200	32.486	06/29/2012 14:56	REAR END, SLOW OR STOP	\$ 3000	0	0	0	1	1	1	1	1	0	0	
Unit	1 : 2	Alchl/Drgs:	0	Speed: 60 MPH Dir: E		Veh Mnvr/Ped Actn: 4				Obj Strk:						
Unit	2 : 1	Alchl/Drgs:	0	Speed: 65 MPH Dir: E		Veh Mnvr/Ped Actn: 4				Obj Strk:						
663	103219475	32.516	08/03/2011 09:05	SIDESWIPE, SAME DIRECTION	\$ 15500	0	0	0	0	1	1	1	5	0	0	
Unit	1 : 14	Alchl/Drgs:	0	Speed: 60 MPH Dir: SE		Veh Mnvr/Ped Actn: 4				Obj Strk:						
Unit	2 : 1	Alchl/Drgs:	0	Speed: 60 MPH Dir: SE		Veh Mnvr/Ped Actn: 4				Obj Strk:						
664	102873706	32.536	05/26/2010 12:49	SIDESWIPE, SAME DIRECTION	\$ 4000	0	0	0	1	1	1	1	1	0	0	
Unit	1 : 13	Alchl/Drgs:	7	Speed: 65 MPH Dir: E		Veh Mnvr/Ped Actn: 16				Obj Strk:						
Unit	2 : 1	Alchl/Drgs:	0	Speed: 65 MPH Dir: E		Veh Mnvr/Ped Actn: 4				Obj Strk:		44				
665	102670250	32.567	09/09/2009 10:32	REAR END, SLOW OR STOP	\$ 1400	0	0	0	0	1	1	1	1	0	0	
Unit	1 : 1	Alchl/Drgs:	0	Speed: 15 MPH Dir: W		Veh Mnvr/Ped Actn: 4				Obj Strk:						
Unit	2 : 4	Alchl/Drgs:	0	Speed: 15 MPH Dir: W		Veh Mnvr/Ped Actn: 11				Obj Strk:						
666	102911213	32.567	07/10/2010 11:44	SIDESWIPE, SAME DIRECTION	\$ 7000	0	0	0	0	1	1	1	1	0	2	1
Unit	1 : 1	Alchl/Drgs:	7	Speed: 65 MPH Dir: SE		Veh Mnvr/Ped Actn: 5				Obj Strk:						
Unit	2 : 1	Alchl/Drgs:	0	Speed: 60 MPH Dir: SE		Veh Mnvr/Ped Actn: 4				Obj Strk:						
667	102659354	32.586	08/10/2009 10:52	REAR END, SLOW OR STOP	\$ 6000	0	0	1	0	1	1	1	1	0	0	
Unit	1 : 10	Alchl/Drgs:	0	Speed: 65 MPH Dir: W		Veh Mnvr/Ped Actn: 4				Obj Strk:						
Unit	2 : 2	Alchl/Drgs:	0	Speed: 65 MPH Dir: W		Veh Mnvr/Ped Actn: 4				Obj Strk:						
668	102739389	32.586	11/18/2009 16:50	FIXED OBJECT	\$ 2400	0	0	0	0	2	2	2	1	5		
Unit	1 : 31	Alchl/Drgs:	0	Speed: 50 MPH Dir: E		Veh Mnvr/Ped Actn: 6				Obj Strk:		42				
669	102997017	32.586	10/24/2010 21:00	FIXED OBJECT	\$ 10000	0	0	0	0	1	5	1	1	0	0	
Unit	1 : 11	Alchl/Drgs:	0	Speed: 50 MPH Dir: E		Veh Mnvr/Ped Actn: 4				Obj Strk:		50				
670	103313567	32.586	11/28/2011 15:52	FIXED OBJECT	\$ 1000	0	0	0	0	2	1	2	1	0	0	
Unit	1 : 2	Alchl/Drgs:	0	Speed: 65 MPH Dir: E		Veh Mnvr/Ped Actn: 4				Obj Strk:		44				
671	103343042	32.586	01/01/2012 13:14	SIDESWIPE, SAME DIRECTION	\$ 4450	0	0	0	0	1	1	1	1	0	0	
Unit	1 : 1	Alchl/Drgs:	0	Speed: 60 MPH Dir: E		Veh Mnvr/Ped Actn: 5				Obj Strk:						
Unit	2 : 1	Alchl/Drgs:	0	Speed: 65 MPH Dir: E		Veh Mnvr/Ped Actn: 4				Obj Strk:						

**North Carolina Department of Transportation
Traffic Engineering Accident Analysis System
Strip Analysis Report**

Acc No	Crash ID	Milepost	Date	Accident Type	Total Damage	Injuries				Condition			Road		Trfc Ctl	
						F	A	B	C	R	L	W	Ch	Ci	Dv	Op
672	102695330	32.667	10/14/2009 14:50	REAR END, SLOW OR STOP	\$ 6700	0	0	0	0	2	1	3	1	0	0	
Unit	1 : 5	Alchl/Drgs:	0	Speed: 55 MPH Dir: S		Veh Mnvr/Ped Actn:				4	Obj Strk:					
Unit	2 : 4	Alchl/Drgs:	0	Speed: 45 MPH Dir: S		Veh Mnvr/Ped Actn:				4	Obj Strk:					
673	103120998	32.667	03/25/2011 16:11	REAR END, SLOW OR STOP	\$ 6300	0	0	0	0	1	1	1	1	0	0	
Unit	1 : 1	Alchl/Drgs:	0	Speed: 50 MPH Dir: W		Veh Mnvr/Ped Actn:				11	Obj Strk:					
Unit	2 : 1	Alchl/Drgs:	0	Speed: 50 MPH Dir: E		Veh Mnvr/Ped Actn:				11	Obj Strk:					
Unit	3 : 1	Alchl/Drgs:	0	Speed: 50 MPH Dir: W		Veh Mnvr/Ped Actn:				11	Obj Strk:					
Unit	4 : 5	Alchl/Drgs:	0	Speed: 50 MPH Dir: W		Veh Mnvr/Ped Actn:				11	Obj Strk:					
674	103179669	32.667	06/16/2011 17:43	MOVABLE OBJECT	\$ 3000	0	0	0	0	1	1	1	1	0	0	
Unit	1 : 1	Alchl/Drgs:	0	Speed: 65 MPH Dir: W		Veh Mnvr/Ped Actn:				4	Obj Strk:		18			
675	103344007	32.667	01/02/2012 19:45	REAR END, SLOW OR STOP	\$ 2700	0	0	0	0	5	5	4	1	0	0	
Unit	1 : 1	Alchl/Drgs:	0	Speed: 40 MPH Dir: S		Veh Mnvr/Ped Actn:				4	Obj Strk:					
Unit	2 : 1	Alchl/Drgs:	0	Speed: 40 MPH Dir: S		Veh Mnvr/Ped Actn:				4	Obj Strk:					
676	103481677	32.686	06/22/2012 16:40	REAR END, SLOW OR STOP	\$ 11500	0	0	1	2	2	1	2	1	0	0	
Unit	1 : 2	Alchl/Drgs:	0	Speed: 55 MPH Dir: W		Veh Mnvr/Ped Actn:				1	Obj Strk:					
Unit	2 : 1	Alchl/Drgs:	0	Speed: 55 MPH Dir: W		Veh Mnvr/Ped Actn:				1	Obj Strk:					
Unit	3 : 1	Alchl/Drgs:	0	Speed: 60 MPH Dir: W		Veh Mnvr/Ped Actn:				4	Obj Strk:					
677	103094201	32.727	02/18/2011 15:11	REAR END, SLOW OR STOP	\$ 4500	0	0	0	0	1	1	1	1	0	0	
Unit	1 : 2	Alchl/Drgs:	0	Speed: 75 MPH Dir: N		Veh Mnvr/Ped Actn:				4	Obj Strk:		42			
Unit	2 : 1	Alchl/Drgs:	0	Speed: 65 MPH Dir: N		Veh Mnvr/Ped Actn:				4	Obj Strk:					
678	102742836	32.786	11/23/2009 22:20	MOVABLE OBJECT	\$ 900	0	0	0	0	1	5	1	1	0	0	
Unit	1 : 14	Alchl/Drgs:	0	Speed: 55 MPH Dir: W		Veh Mnvr/Ped Actn:				4	Obj Strk:					
Unit	2 : 1	Alchl/Drgs:	0	Speed: 55 MPH Dir: W		Veh Mnvr/Ped Actn:				4	Obj Strk:		18			
679	103247552	32.927	09/11/2011 11:15	FIXED OBJECT	\$ 1400	0	0	0	0	1	1	1	1	0	0	
Unit	1 : 1	Alchl/Drgs:	0	Speed: 55 MPH Dir: E		Veh Mnvr/Ped Actn:				4	Obj Strk:		42			
680	102664964	33.067	08/31/2009 11:44	MOVABLE OBJECT	\$ 900	0	0	0	0	2	1	2	1	0	0	
Unit	1 : 1	Alchl/Drgs:	0	Speed: 65 MPH Dir: E		Veh Mnvr/Ped Actn:				4	Obj Strk:		18			
Unit	2 : 5	Alchl/Drgs:	0	Speed: 65 MPH Dir: E		Veh Mnvr/Ped Actn:				4	Obj Strk:					

**North Carolina Department of Transportation
Traffic Engineering Accident Analysis System
Strip Analysis Report**

Acc No	Crash ID	Milepost	Date	Accident Type	Total Damage	Injuries				Condition			Road		Trfc Ctl	
						F	A	B	C	R	L	W	Ch	Ci	Dv	Op
681	102995873	33.133	10/24/2010 21:05	MOVABLE OBJECT	\$ 15000	0	0	0	0	1	5	1	1	0	0	
Unit	1 : 11	Alchl/Drgs:	0	Speed:	55 MPH Dir: E	Veh Mnvr/Ped Actn:				4	Obj Strk:		18			
Unit	2 : 1	Alchl/Drgs:	0	Speed:	65 MPH Dir: E	Veh Mnvr/Ped Actn:				4	Obj Strk:		18			
682	102996079	33.133	10/24/2010 21:11	MOVABLE OBJECT	\$ 12800	0	0	0	0	1	5	2	1	0	0	
Unit	1 : 11	Alchl/Drgs:	0	Speed:	50 MPH Dir: E	Veh Mnvr/Ped Actn:				4	Obj Strk:		18			
Unit	2 : 1	Alchl/Drgs:	0	Speed:	60 MPH Dir: E	Veh Mnvr/Ped Actn:				4	Obj Strk:		18			
683	102731707	33.186	11/07/2009 03:55	ANIMAL	\$ 1500	0	0	0	0	1	5	1	1	0	0	
Unit	1 : 1	Alchl/Drgs:	0	Speed:	60 MPH Dir: W	Veh Mnvr/Ped Actn:				4	Obj Strk:		17			
684	102942919	33.193	08/20/2010 13:11	FIXED OBJECT	\$ 1500	0	0	0	0	1	1	1	1	0	0	
Unit	1 : 1	Alchl/Drgs:	0	Speed:	65 MPH Dir: W	Veh Mnvr/Ped Actn:				4	Obj Strk:		42			
685	103504005	33.193	07/21/2012 12:01	REAR END, SLOW OR STOP	\$ 5000	0	0	0	0	1	1	2	1	0	0	
Unit	1 : 4	Alchl/Drgs:	0	Speed:	60 MPH Dir: W	Veh Mnvr/Ped Actn:				4	Obj Strk:					
Unit	2 : 4	Alchl/Drgs:	0	Speed:	60 MPH Dir: W	Veh Mnvr/Ped Actn:				4	Obj Strk:					
686	103191204	33.227	07/03/2011 06:39	FIXED OBJECT	\$ 4250	0	0	1	0	1	1	1	5	0	0	
Unit	1 : 3	Alchl/Drgs:	0	Speed:	65 MPH Dir: SE	Veh Mnvr/Ped Actn:				4	Obj Strk:		42			
687	103298200	33.286	11/09/2011 21:00	SIDESWIPE, SAME DIRECTION	\$ 800	0	0	0	0	2	5	3	1	0	0	
Unit	1 : 14	Alchl/Drgs:	0	Speed:	55 MPH Dir: E	Veh Mnvr/Ped Actn:				5	Obj Strk:					
Unit	2 : 1	Alchl/Drgs:	0	Speed:	55 MPH Dir: E	Veh Mnvr/Ped Actn:				4	Obj Strk:					
688	103214385	33.293	07/30/2011 13:32	RAN OFF ROAD - LEFT	\$ 1500	0	0	0	0	1	1	1	1	0	0	
Unit	1 : 2	Alchl/Drgs:	0	Speed:	45 MPH Dir: W	Veh Mnvr/Ped Actn:				4	Obj Strk:		18			
689	102650709	33.386	08/09/2009 14:45	RAN OFF ROAD - LEFT	\$ 3300	0	0	0	0	1	1	1	1	0	0	
Unit	1 : 1	Alchl/Drgs:	0	Speed:	50 MPH Dir: E	Veh Mnvr/Ped Actn:				4	Obj Strk:					
Unit	2 : 2	Alchl/Drgs:	0	Speed:	45 MPH Dir: E	Veh Mnvr/Ped Actn:				4	Obj Strk:					
690	102871087	33.427	05/18/2010 18:54	SIDESWIPE, SAME DIRECTION	\$ 650	0	0	0	0	1	1	1	1	0	0	
Unit	1 : 2	Alchl/Drgs:	0	Speed:	65 MPH Dir: W	Veh Mnvr/Ped Actn:				4	Obj Strk:					
Unit	2 : 1	Alchl/Drgs:	7	Speed:	65 MPH Dir: W	Veh Mnvr/Ped Actn:				4	Obj Strk:					

**North Carolina Department of Transportation
Traffic Engineering Accident Analysis System
Strip Analysis Report**

Acc No	Crash ID	Milepost	Date	Accident Type	Total Damage	Injuries				Condition			Road		Trfc Ctl	
						F	A	B	C	R	L	W	Ch	Ci	Dv	Op
691	102749717	33.486	12/18/2009 14:30	RAN OFF ROAD - RIGHT	\$ 3000	0	0	0	0	5	1	4	1	0	0	
Unit	1 : 2	Alchl/Drgs:	0	Speed: 40 MPH	Dir: W	Veh Mnvr/Ped Actn:				4	Obj Strk:		59			
692	103259032	33.486	09/25/2011 01:42	RAN OFF ROAD - RIGHT	\$ 75	0	0	0	1	1	5	2	1	0	0	
Unit	1 : 1	Alchl/Drgs:	7	Speed: 55 MPH	Dir: E	Veh Mnvr/Ped Actn:				4	Obj Strk:		42			
693	103253809	33.493	09/19/2011 02:10	REAR END, SLOW OR STOP	\$ 10000	0	0	1	1	1	5	2	1	0	0	
Unit	1 : 5	Alchl/Drgs:	0	Speed: 30 MPH	Dir: W	Veh Mnvr/Ped Actn:				4	Obj Strk:					
Unit	2 : 1	Alchl/Drgs:	0	Speed: 70 MPH	Dir: W	Veh Mnvr/Ped Actn:				4	Obj Strk:					
694	102792360	33.586	02/12/2010 18:00	FIXED OBJECT	\$ 2000	0	0	0	0	5	2	4	1	0	0	
Unit	1 : 4	Alchl/Drgs:	0	Speed: 55 MPH	Dir: NW	Veh Mnvr/Ped Actn:				4	Obj Strk:		59			
695	103488210	33.586	07/01/2012 16:25	REAR END, SLOW OR STOP	\$ 1850	0	0	0	0	1	1	1	1	0	0	
Unit	1 : 1	Alchl/Drgs:	0	Speed: 65 MPH	Dir: E	Veh Mnvr/Ped Actn:				4	Obj Strk:					
Unit	2 : 1	Alchl/Drgs:	0	Speed: 65 MPH	Dir: E	Veh Mnvr/Ped Actn:				4	Obj Strk:					
696	102696620	33.693	10/04/2009 02:14	PARKED MOTOR VEHICLE	\$ 17000	1	0	0	0	1	5	1	1	0	0	
Unit	1 : 10	Alchl/Drgs:	7	Speed: 0 MPH	Dir: NE	Veh Mnvr/Ped Actn:				3	Obj Strk:		20			
Unit	2 : 1	Alchl/Drgs:	0	Speed: 65 MPH	Dir: N	Veh Mnvr/Ped Actn:				4	Obj Strk:		20			
697	102723434	33.786	11/16/2009 17:17	FIXED OBJECT	\$ 1500	0	0	0	0	1	1	2	1	0	0	
Unit	1 : 1	Alchl/Drgs:	0	Speed: 60 MPH	Dir: SE	Veh Mnvr/Ped Actn:				4	Obj Strk:		44			
698	102991507	33.786	10/21/2010 16:04	REAR END, SLOW OR STOP	\$ 3100	0	0	0	0	1	1	1	3	0	0	
Unit	1 : 14	Alchl/Drgs:	0	Speed: 65 MPH	Dir: W	Veh Mnvr/Ped Actn:				11	Obj Strk:					
Unit	2 : 1	Alchl/Drgs:	0	Speed: 65 MPH	Dir: W	Veh Mnvr/Ped Actn:				4	Obj Strk:					
699	103344038	33.916	01/03/2012 00:22	FIXED OBJECT	\$ 2000	0	0	0	0	5	5	4	1	0	0	
Unit	1 : 1	Alchl/Drgs:	0	Speed: 45 MPH	Dir: N	Veh Mnvr/Ped Actn:				4	Obj Strk:		59			
700	103299037	33.986	11/06/2011 09:50	MOVABLE OBJECT	\$ 1100	0	0	0	0	1	1	1	1	0	0	
Unit	1 : 4	Alchl/Drgs:	0	Speed: 65 MPH	Dir: W	Veh Mnvr/Ped Actn:				4	Obj Strk:					
Unit	2 : 1	Alchl/Drgs:	0	Speed: 65 MPH	Dir: W	Veh Mnvr/Ped Actn:				4	Obj Strk:		18			
701	103106992	34.016	03/08/2011 21:32	FIXED OBJECT	\$ 3000	0	0	0	0	1	5	1	1	0	0	
Unit	1 : 1	Alchl/Drgs:	0	Speed: 65 MPH	Dir: W	Veh Mnvr/Ped Actn:				4	Obj Strk:		42			

**North Carolina Department of Transportation
Traffic Engineering Accident Analysis System
Strip Analysis Report**

Acc No	Crash ID	Milepost	Date	Accident Type	Total Damage	Injuries				Condition			Road		Trfc Ctl	
						F	A	B	C	R	L	W	Ch	Ci	Dv	Op
702	102709091	34.093	11/01/2009 02:00	FIXED OBJECT	\$ 2000	0	0	0	0	2	5	3	1	6	0	
Unit	1 : 2	Alchl/Drgs:	0	Speed:	65 MPH	Dir:	N	Veh Mnvr/Ped Actn:				4	Obj Strk:		33	
703	102996172	34.186	10/27/2010 00:40	MOVABLE OBJECT	\$ 1000	0	0	0	0	2	5	2	3	0	0	
Unit	1 : 5	Alchl/Drgs:	0	Speed:	65 MPH	Dir:	W	Veh Mnvr/Ped Actn:				4	Obj Strk:		18	
704	103470190	34.316	06/04/2012 15:30	REAR END, SLOW OR STOP	\$ 3600	0	0	0	0	1	1	1	1	0	0	
Unit	1 : 2	Alchl/Drgs:	0	Speed:	60 MPH	Dir:	E	Veh Mnvr/Ped Actn:				4	Obj Strk:			
Unit	2 : 1	Alchl/Drgs:	0	Speed:	60 MPH	Dir:	E	Veh Mnvr/Ped Actn:				11	Obj Strk:			
705	102683616	34.386	09/16/2009 18:55	SIDESWIPE, SAME DIRECTION	\$ 700	0	0	0	0	1	1	2	1	0	0	
Unit	1 : 5	Alchl/Drgs:	7	Speed:	70 MPH	Dir:	E	Veh Mnvr/Ped Actn:				5	Obj Strk:			
Unit	2 : 1	Alchl/Drgs:	0	Speed:	65 MPH	Dir:	E	Veh Mnvr/Ped Actn:				4	Obj Strk:			
706	102927064	34.467	08/02/2010 17:00	RAN OFF ROAD - RIGHT	\$ 1300	0	0	0	0	1	1	2	1	0	0	
Unit	1 : 2	Alchl/Drgs:	0	Speed:	55 MPH	Dir:	E	Veh Mnvr/Ped Actn:				4	Obj Strk:		42	
707	103331847	34.486	12/17/2011 15:50	OTHER COLLISION WITH VEHICLE	\$ 2750	0	0	0	0	1	1	1	1	0	0	
Unit	1 : 5	Alchl/Drgs:	2	Speed:	65 MPH	Dir:	E	Veh Mnvr/Ped Actn:				5	Obj Strk:			
Unit	2 : 4	Alchl/Drgs:	0	Speed:	65 MPH	Dir:	E	Veh Mnvr/Ped Actn:				4	Obj Strk:			
708	103255423	34.493	09/20/2011 15:09	RAN OFF ROAD - RIGHT	\$ 6000	0	0	1	0	1	1	2	1	0	0	
Unit	1 : 4	Alchl/Drgs:	0	Speed:	70 MPH	Dir:	NW	Veh Mnvr/Ped Actn:				4	Obj Strk:		33	
709	102702791	34.516	10/15/2009 06:25	MOVABLE OBJECT	\$ 200	0	0	0	0	2	3	2	1	0	0	
Unit	1 : 1	Alchl/Drgs:	0	Speed:	65 MPH	Dir:	W	Veh Mnvr/Ped Actn:				4	Obj Strk:		18	
710	103067779	34.516	01/15/2011 06:50	MOVABLE OBJECT	\$ 600	0	0	0	0	1	1	1	1	0	0	
Unit	1 : 4	Alchl/Drgs:	0	Speed:	60 MPH	Dir:	SE	Veh Mnvr/Ped Actn:				4	Obj Strk:		18	
711	103507427	34.616	07/27/2012 16:30	REAR END, SLOW OR STOP	\$ 4000	0	0	0	1	1	1	1	7	0	0	
Unit	1 : 1	Alchl/Drgs:	0	Speed:	50 MPH	Dir:	SE	Veh Mnvr/Ped Actn:				4	Obj Strk:			
Unit	2 : 2	Alchl/Drgs:	0	Speed:	40 MPH	Dir:	SE	Veh Mnvr/Ped Actn:				4	Obj Strk:			
712	102742654	34.686	11/20/2009 19:16	REAR END, SLOW OR STOP	\$ 37300	0	0	3	4	1	5	1	1	0	10	1
Unit	1 : 14	Alchl/Drgs:	0	Speed:	55 MPH	Dir:	N	Veh Mnvr/Ped Actn:				4	Obj Strk:			

**North Carolina Department of Transportation
Traffic Engineering Accident Analysis System
Strip Analysis Report**

Acc No	Crash ID	Milepost	Date	Accident Type	Total Damage	Injuries				Condition			Road		Trfc Ctl		
						F	A	B	C	R	L	W	Ch	Ci	Dv	Op	
Unit	2 : 3	Alchl/Drugs:	0	Speed:	40 MPH	Dir:	N	Veh Mnvr/Ped Actn:				1	Obj Strk:				
Unit	3 : 1	Alchl/Drugs:	0	Speed:	40 MPH	Dir:	N	Veh Mnvr/Ped Actn:				1	Obj Strk:				
Unit	4 : 1	Alchl/Drugs:	0	Speed:	40 MPH	Dir:	N	Veh Mnvr/Ped Actn:				1	Obj Strk:				
713	103487809	34.716	06/30/2012 15:29	REAR END, SLOW OR STOP	\$ 4300			0	0	0	0	1	1	1	1	0	0
Unit	1 : 4	Alchl/Drugs:	0	Speed:	65 MPH	Dir:	NW	Veh Mnvr/Ped Actn:				11	Obj Strk:				
Unit	2 : 1	Alchl/Drugs:	0	Speed:	65 MPH	Dir:	NW	Veh Mnvr/Ped Actn:				4	Obj Strk:				
Unit	3 : 1	Alchl/Drugs:	0	Speed:	65 MPH	Dir:	NW	Veh Mnvr/Ped Actn:				11	Obj Strk:				
Unit	4 : 1	Alchl/Drugs:	0	Speed:	65 MPH	Dir:	NW	Veh Mnvr/Ped Actn:				4	Obj Strk:				
714	102991488	34.816	10/21/2010 14:03	MOVABLE OBJECT	\$ 500			0	0	0	0	1	1	1	1	0	0
Unit	1 : 2	Alchl/Drugs:	0	Speed:	65 MPH	Dir:	E	Veh Mnvr/Ped Actn:				4	Obj Strk:				
Unit	2 : 1	Alchl/Drugs:	0	Speed:	65 MPH	Dir:	E	Veh Mnvr/Ped Actn:				4	Obj Strk:				
715	103191179	34.816	07/01/2011 13:45	FIXED OBJECT	\$ 1500			0	0	0	0	1	1	1	1	0	0
Unit	1 : 5	Alchl/Drugs:	0	Speed:	65 MPH	Dir:	W	Veh Mnvr/Ped Actn:				4	Obj Strk: 44				
716	102750366	34.886	11/25/2009 17:50	REAR END, SLOW OR STOP	\$ 3400			0	0	0	0	1	5	1	1	0	0
Unit	1 : 10	Alchl/Drugs:	0	Speed:	45 MPH	Dir:	E	Veh Mnvr/Ped Actn:				4	Obj Strk:				
Unit	2 : 4	Alchl/Drugs:	0	Speed:	45 MPH	Dir:	E	Veh Mnvr/Ped Actn:				11	Obj Strk:				
Unit	3 : 4	Alchl/Drugs:	7	Speed:	45 MPH	Dir:	E	Veh Mnvr/Ped Actn:				11	Obj Strk:				
717	102785514	34.916	02/08/2010 07:09	REAR END, SLOW OR STOP	\$ 26000			0	0	1	1	1	3	2	1	0	0
Unit	1 : 6	Alchl/Drugs:	0	Speed:	60 MPH	Dir:	E	Veh Mnvr/Ped Actn:				4	Obj Strk:				
Unit	2 : 2	Alchl/Drugs:	0	Speed:	35 MPH	Dir:	E	Veh Mnvr/Ped Actn:				11	Obj Strk:				
Unit	3 : 2	Alchl/Drugs:	0	Speed:	35 MPH	Dir:	E	Veh Mnvr/Ped Actn:				11	Obj Strk:				
Unit	4 : 2	Alchl/Drugs:	0	Speed:	30 MPH	Dir:	E	Veh Mnvr/Ped Actn:				11	Obj Strk:				
718	102862174	34.916	05/11/2010 08:47	SIDESWIPE, SAME DIRECTION	\$ 4000			0	0	0	1	2	1	2	1	0	0
Unit	1 : 1	Alchl/Drugs:	0	Speed:	65 MPH	Dir:	W	Veh Mnvr/Ped Actn:				4	Obj Strk:				
Unit	2 : 1	Alchl/Drugs:	0	Speed:	65 MPH	Dir:	W	Veh Mnvr/Ped Actn:				5	Obj Strk:				
719	103167305	34.916	05/24/2011 15:14	FIXED OBJECT	\$ 6800			0	0	0	1	1	1	1	1	0	0
Unit	1 : 1	Alchl/Drugs:	0	Speed:	65 MPH	Dir:	S	Veh Mnvr/Ped Actn:				4	Obj Strk: 44				
720	103277206	34.916	10/17/2011 11:58	REAR END, SLOW OR STOP	\$ 1000			0	0	0	0	1	1	1	1	0	0
Unit	1 : 1	Alchl/Drugs:	0	Speed:	15 MPH	Dir:	W	Veh Mnvr/Ped Actn:				4	Obj Strk:				
Unit	2 : 5	Alchl/Drugs:	0	Speed:	15 MPH	Dir:	W	Veh Mnvr/Ped Actn:				4	Obj Strk:				

**North Carolina Department of Transportation
Traffic Engineering Accident Analysis System
Strip Analysis Report**

Acc No	Crash ID	Milepost	Date	Accident Type	Total Damage	Injuries				Condition			Road		Trfc Ctl	
						F	A	B	C	R	L	W	Ch	Ci	Dv	Op
721	103359108	34.916	01/22/2012 06:23	RAN OFF ROAD - RIGHT	\$ 4000	0	0	0	0	2	4	2	1	0	0	
Unit	1 : 2	Alchl/Drgs:	0	Speed: 65 MPH	Dir: W	Veh Mnvr/Ped Actn:				16	Obj Strk:		18			
722	102697634	34.993	10/18/2009 13:50	REAR END, SLOW OR STOP	\$ 9000	0	0	0	1	1	1	1	1	0	0	
Unit	1 : 1	Alchl/Drgs:	0	Speed: 30 MPH	Dir: E	Veh Mnvr/Ped Actn:				4	Obj Strk:					
Unit	2 : 4	Alchl/Drgs:	0	Speed: 0 MPH	Dir: E	Veh Mnvr/Ped Actn:				1	Obj Strk:					
723	103344027	34.993	01/02/2012 21:19	FIXED OBJECT	\$ 6000	0	0	0	0	5	5	4	3	0	0	
Unit	1 : 2	Alchl/Drgs:	0	Speed: 45 MPH	Dir: N	Veh Mnvr/Ped Actn:				4	Obj Strk:		44			
Unit	2 : 1	Alchl/Drgs:	0	Speed: 40 MPH	Dir: N	Veh Mnvr/Ped Actn:				4	Obj Strk:					
724	103046784	35.016	12/20/2010 06:41	SIDESWIPE, SAME DIRECTION	\$ 8000	0	0	0	0	1	5	1	1	0	0	
Unit	1 : 14	Alchl/Drgs:	0	Speed: 60 MPH	Dir: W	Veh Mnvr/Ped Actn:				4	Obj Strk:					
Unit	2 : 2	Alchl/Drgs:	0	Speed: 60 MPH	Dir: W	Veh Mnvr/Ped Actn:				4	Obj Strk:					
725	103344008	35.056	01/02/2012 19:44	FIXED OBJECT	\$ 3500	0	0	0	0	5	5	4	1	0	0	
Unit	1 : 2	Alchl/Drgs:	0	Speed: 45 MPH	Dir: S	Veh Mnvr/Ped Actn:				4	Obj Strk:		42			
726	102981261	35.216	10/08/2010 16:56	REAR END, SLOW OR STOP	\$ 4500	0	0	0	0	1	1	1	1	0	0	
Unit	1 : 2	Alchl/Drgs:	0	Speed: 55 MPH	Dir: W	Veh Mnvr/Ped Actn:				4	Obj Strk:					
Unit	2 : 2	Alchl/Drgs:	0	Speed: 45 MPH	Dir: W	Veh Mnvr/Ped Actn:				4	Obj Strk:					
Unit	3 : 1	Alchl/Drgs:	0	Speed: 0 MPH	Dir: W	Veh Mnvr/Ped Actn:				1	Obj Strk:		44			
727	103181970	35.216	06/20/2011 16:43	FIXED OBJECT	\$ 7750	0	0	0	0	1	1	1	1	0	0	
Unit	1 : 1	Alchl/Drgs:	0	Speed: 65 MPH	Dir: W	Veh Mnvr/Ped Actn:				4	Obj Strk:		44			
728	103438528	35.286	04/29/2012 17:56	SIDESWIPE, SAME DIRECTION	\$ 4400	0	0	0	0	1	1	1	1	0	0	
Unit	1 : 14	Alchl/Drgs:	0	Speed: 65 MPH	Dir: E	Veh Mnvr/Ped Actn:				5	Obj Strk:					
Unit	2 : 1	Alchl/Drgs:	0	Speed: 65 MPH	Dir: E	Veh Mnvr/Ped Actn:				4	Obj Strk:					
729	103467845	35.286	06/05/2012 14:29	REAR END, SLOW OR STOP	\$ 2500	0	0	0	1	1	1	1	1	0	0	
Unit	1 : 1	Alchl/Drgs:	0	Speed: 65 MPH	Dir: E	Veh Mnvr/Ped Actn:				4	Obj Strk:					
Unit	2 : 2	Alchl/Drgs:	0	Speed: 65 MPH	Dir: E	Veh Mnvr/Ped Actn:				11	Obj Strk:					
730	102809274	35.293	03/06/2010 15:11	MOVABLE OBJECT	\$ 4500	0	0	0	0	1	1	1	1	2	0	
Unit	1 : 1	Alchl/Drgs:	0	Speed: 65 MPH	Dir: W	Veh Mnvr/Ped Actn:				4	Obj Strk:		18			

**North Carolina Department of Transportation
Traffic Engineering Accident Analysis System
Strip Analysis Report**

Acc No	Crash ID	Milepost	Date	Accident Type	Total Damage	Injuries				Condition			Road		Trfc Ctl	
						F	A	B	C	R	L	W	Ch	Ci	Dv	Op
731	102666316	35.386	08/19/2009 20:32	OTHER NON-COLLISION	\$ 1800	0	0	0	0	1	5	2	1	0	0	
Unit	1 : 1	Alchl/Drgs:	0	Speed:	65 MPH Dir: NW	Veh Mnvr/Ped Actn:				4	Obj Strk:					
732	103319255	35.416	12/04/2011 20:22	ANIMAL	\$ 4500	0	0	0	0	1	5	1	1	0	0	
Unit	1 : 4	Alchl/Drgs:	0	Speed:	60 MPH Dir: NW	Veh Mnvr/Ped Actn:				4	Obj Strk: 17					
733	102980619	35.493	10/08/2010 16:02	REAR END, SLOW OR STOP	\$ 1700	0	0	0	0	1	1	1	1	0	0	
Unit	1 : 2	Alchl/Drgs:	0	Speed:	45 MPH Dir: W	Veh Mnvr/Ped Actn:				4	Obj Strk:					
Unit	2 : 5	Alchl/Drgs:	0	Speed:	35 MPH Dir: W	Veh Mnvr/Ped Actn:				11	Obj Strk:					
734	103252916	35.493	09/13/2011 07:37	SIDESWIPE, SAME DIRECTION	\$ 3100	0	0	0	0	10	1	1	1	0	0	
Unit	1 : 12	Alchl/Drgs:	0	Speed:	60 MPH Dir: N	Veh Mnvr/Ped Actn:				4	Obj Strk:					
Unit	2 : 1	Alchl/Drgs:	0	Speed:	65 MPH Dir: N	Veh Mnvr/Ped Actn:				4	Obj Strk:					
735	102984916	35.586	10/13/2010 15:25	REAR END, SLOW OR STOP	\$ 2550	0	0	0	0	1	1	1	5	0	0	
Unit	1 : 2	Alchl/Drgs:	0	Speed:	40 MPH Dir: W	Veh Mnvr/Ped Actn:				4	Obj Strk:					
Unit	2 : 11	Alchl/Drgs:	0	Speed:	65 MPH Dir: W	Veh Mnvr/Ped Actn:				4	Obj Strk:					
736	103151696	35.586	05/08/2011 17:46	FIXED OBJECT	\$ 9600	0	0	0	0	1	1	1	3	0	0	
Unit	1 : 2	Alchl/Drgs:	1	Speed:	60 MPH Dir: W	Veh Mnvr/Ped Actn:				4	Obj Strk: 42					
737	102980639	35.693	10/08/2010 17:25	REAR END, SLOW OR STOP	\$ 32000	0	0	0	0	1	1	1	1	0	0	
Unit	1 : 2	Alchl/Drgs:	0	Speed:	60 MPH Dir: W	Veh Mnvr/Ped Actn:				4	Obj Strk:					
Unit	2 : 1	Alchl/Drgs:	0	Speed:	65 MPH Dir: W	Veh Mnvr/Ped Actn:				11	Obj Strk:					
Unit	3 : 4	Alchl/Drgs:	0	Speed:	65 MPH Dir: W	Veh Mnvr/Ped Actn:				11	Obj Strk:					
Unit	4 : 1	Alchl/Drgs:	0	Speed:	65 MPH Dir: W	Veh Mnvr/Ped Actn:				11	Obj Strk:					
738	102892098	35.816	06/19/2010 17:24	REAR END, SLOW OR STOP	\$ 7150	0	0	1	0	1	1	1	1	0	0	
Unit	1 : 5	Alchl/Drgs:	0	Speed:	65 MPH Dir: E	Veh Mnvr/Ped Actn:				4	Obj Strk:					
Unit	2 : 4	Alchl/Drgs:	0	Speed:	65 MPH Dir: E	Veh Mnvr/Ped Actn:				4	Obj Strk:					
739	102980616	35.893	10/04/2010 17:28	REAR END, SLOW OR STOP	\$ 2300	0	0	0	0	1	1	1	1	0	0	
Unit	1 : 2	Alchl/Drgs:	0	Speed:	65 MPH Dir: W	Veh Mnvr/Ped Actn:				4	Obj Strk:					
Unit	2 : 4	Alchl/Drgs:	0	Speed:	65 MPH Dir: W	Veh Mnvr/Ped Actn:				11	Obj Strk:					
740	102980615	35.893	10/08/2010 16:43	REAR END, SLOW OR STOP	\$ 4900	0	0	0	0	1	1	1	1	0	0	
Unit	1 : 14	Alchl/Drgs:	0	Speed:	45 MPH Dir: W	Veh Mnvr/Ped Actn:				4	Obj Strk:					

**North Carolina Department of Transportation
Traffic Engineering Accident Analysis System
Strip Analysis Report**

Acc No	Crash ID	Milepost	Date	Accident Type	Total Damage	Injuries				Condition			Road		Trfc Ctl		
						F	A	B	C	R	L	W	Ch	Ci	Dv	Op	
Unit	2 : 2	Alchl/Drgs:	0	Speed:	45 MPH	Dir:	W	Veh Mnvr/Ped Actn:				11	Obj Strk:				
Unit	3 : 4	Alchl/Drgs:	0	Speed:	45 MPH	Dir:	W	Veh Mnvr/Ped Actn:				11	Obj Strk:				
741	102675407	35.927	08/22/2009 14:30	REAR END, SLOW OR STOP	\$ 22500			0	0	6	2	1	1	1	3	0	
Unit	1 : 5	Alchl/Drgs:	0	Speed:	65 MPH	Dir:	W	Veh Mnvr/Ped Actn:				4	Obj Strk:				
Unit	2 : 4	Alchl/Drgs:	0	Speed:	0 MPH	Dir:	W	Veh Mnvr/Ped Actn:				1	Obj Strk:				
Unit	3 : 1	Alchl/Drgs:	0	Speed:	0 MPH	Dir:	W	Veh Mnvr/Ped Actn:				1	Obj Strk:				
Unit	4 : 2	Alchl/Drgs:	0	Speed:	0 MPH	Dir:	W	Veh Mnvr/Ped Actn:				1	Obj Strk:				
742	103238240	35.927	08/21/2011 12:45	REAR END, SLOW OR STOP	\$ 4800			0	0	0	0	1	1	1	3	0	0
Unit	1 : 4	Alchl/Drgs:	0	Speed:	40 MPH	Dir:	E	Veh Mnvr/Ped Actn:				11	Obj Strk:				
Unit	2 : 2	Alchl/Drgs:	0	Speed:	40 MPH	Dir:	E	Veh Mnvr/Ped Actn:				11	Obj Strk:				
Unit	3 : 2	Alchl/Drgs:	0	Speed:	65 MPH	Dir:	E	Veh Mnvr/Ped Actn:				4	Obj Strk:				
Unit	4 : 2	Alchl/Drgs:	0	Speed:	65 MPH	Dir:	E	Veh Mnvr/Ped Actn:				4	Obj Strk:				
743	102721151	36.027	10/31/2009 15:30	FIXED OBJECT	\$ 9000			0	0	0	0	2	1	3	1	0	0
Unit	1 : 1	Alchl/Drgs:	0	Speed:	55 MPH	Dir:	W	Veh Mnvr/Ped Actn:				4	Obj Strk: 44				
744	102776784	36.193	01/28/2010 05:32	ANIMAL	\$ 2500			0	0	0	0	1	5	1	1	0	0
Unit	1 : 2	Alchl/Drgs:	0	Speed:	65 MPH	Dir:	W	Veh Mnvr/Ped Actn:				4	Obj Strk: 17				
745	102882371	36.327	06/06/2010 23:30	MOVABLE OBJECT	\$ 2500			0	0	0	0	1	5	1	1	2	0
Unit	1 : 1	Alchl/Drgs:	0	Speed:	60 MPH	Dir:	SE	Veh Mnvr/Ped Actn:				4	Obj Strk: 18				
746	102746180	36.393	12/17/2009 02:19	ANIMAL	\$ 5000			0	0	0	0	1	5	1	3	0	0
Unit	1 : 2	Alchl/Drgs:	0	Speed:	60 MPH	Dir:	W	Veh Mnvr/Ped Actn:				4	Obj Strk: 17				
747	103471637	36.393	06/10/2012 20:54	REAR END, SLOW OR STOP	\$ 9500			0	0	3	0	2	3	3	1	0	0
Unit	1 : 1	Alchl/Drgs:	5	Speed:	100 MPH	Dir:	W	Veh Mnvr/Ped Actn:				4	Obj Strk: 44				
Unit	2 : 4	Alchl/Drgs:	0	Speed:	65 MPH	Dir:	W	Veh Mnvr/Ped Actn:				4	Obj Strk: 42				
748	103510385	36.627	07/31/2012 08:11	SIDESWIPE, SAME DIRECTION	\$ 2000			0	0	0	0	1	1	2	1	0	0
Unit	1 : 1	Alchl/Drgs:	0	Speed:	65 MPH	Dir:	NW	Veh Mnvr/Ped Actn:				5	Obj Strk:				
Unit	2 : 4	Alchl/Drgs:	0	Speed:	65 MPH	Dir:	NW	Veh Mnvr/Ped Actn:				4	Obj Strk:				
749	102846943	36.693	04/23/2010 16:00	MOVABLE OBJECT	\$ 3000			0	0	0	0	1	1	1	1	0	0
Unit	1 : 14	Alchl/Drgs:	0	Speed:	60 MPH	Dir:	E	Veh Mnvr/Ped Actn:				5	Obj Strk: 18				

**North Carolina Department of Transportation
Traffic Engineering Accident Analysis System
Strip Analysis Report**

Acc No	Crash ID	Milepost	Date	Accident Type	Total Damage	Injuries				Condition			Road		Trfc Ctl	
						F	A	B	C	R	L	W	Ch	Ci	Dv	Op
750	102881191	36.727	06/06/2010 14:15	SIDESWIPE, SAME DIRECTION	\$ 3900	0	0	0	0	1	1	1	3	0	0	
Unit	1 : 1	Alchl/Drgs:	0	Speed: 65 MPH Dir: E		Veh Mnvr/Ped Actn:				4	Obj Strk:					
Unit	2 : 1	Alchl/Drgs:	0	Speed: 65 MPH Dir: E		Veh Mnvr/Ped Actn:				5	Obj Strk:					
751	103434784	36.727	04/08/2012 18:23	OVERTURN/ROLLOVER	\$ 2000	0	0	4	0	1	1	1	7	0	0	
Unit	1 : 4	Alchl/Drgs:	0	Speed: 65 MPH Dir: NW		Veh Mnvr/Ped Actn:				4	Obj Strk:					
752	102873386	36.793	05/27/2010 10:50	REAR END, SLOW OR STOP	\$ 1550	0	0	0	0	1	1	1	3	0	0	
Unit	1 : 2	Alchl/Drgs:	0	Speed: 45 MPH Dir: E		Veh Mnvr/Ped Actn:				4	Obj Strk:					
Unit	2 : 4	Alchl/Drgs:	0	Speed: 45 MPH Dir: E		Veh Mnvr/Ped Actn:				1	Obj Strk:					
Unit	3 : 4	Alchl/Drgs:	0	Speed: 35 MPH Dir: E		Veh Mnvr/Ped Actn:				1	Obj Strk:					
753	103400750	36.886	03/11/2012 16:15	SIDESWIPE, SAME DIRECTION	\$ 1800	0	0	0	0	1	1	1	5	0	0	
Unit	1 : 1	Alchl/Drgs:	0	Speed: 65 MPH Dir: E		Veh Mnvr/Ped Actn:				4	Obj Strk:		42			
Unit	2 : 5	Alchl/Drgs:	0	Speed: 65 MPH Dir: W		Veh Mnvr/Ped Actn:				5	Obj Strk:					
754	102780622	37.186	01/29/2010 19:45	REAR END, SLOW OR STOP	\$ 3500	0	0	0	0	5	5	2	3	0	0	
Unit	1 : 4	Alchl/Drgs:	0	Speed: 40 MPH Dir: W		Veh Mnvr/Ped Actn:				11	Obj Strk:					
Unit	2 : 1	Alchl/Drgs:	0	Speed: 40 MPH Dir: W		Veh Mnvr/Ped Actn:				11	Obj Strk:					
755	103358944	37.186	01/21/2012 01:51	OTHER NON-COLLISION	\$ 1000	0	0	0	0	2	5	3	1	0	0	
Unit	1 : 15	Alchl/Drgs:	0	Speed: 60 MPH Dir: W		Veh Mnvr/Ped Actn:				4	Obj Strk:					
756	103420164	37.186	04/08/2012 10:48	REAR END, SLOW OR STOP	\$ 2200	0	0	0	0	1	1	1	1	0	0	
Unit	1 : 1	Alchl/Drgs:	0	Speed: 60 MPH Dir: W		Veh Mnvr/Ped Actn:				4	Obj Strk:					
Unit	2 : 5	Alchl/Drgs:	0	Speed: 50 MPH Dir: W		Veh Mnvr/Ped Actn:				11	Obj Strk:					
757	102860747	37.193	05/10/2010 17:47	SIDESWIPE, SAME DIRECTION	\$ 3800	0	0	0	0	2	1	3	1	0	0	
Unit	1 : 14	Alchl/Drgs:	0	Speed: 65 MPH Dir: W		Veh Mnvr/Ped Actn:				4	Obj Strk:					
Unit	2 : 1	Alchl/Drgs:	0	Speed: 65 MPH Dir: W		Veh Mnvr/Ped Actn:				4	Obj Strk:		44			
758	103155943	37.193	05/12/2011 14:49	RAN OFF ROAD - LEFT	\$ 8900	0	0	0	0	2	1	3	5	0	0	
Unit	1 : 1	Alchl/Drgs:	0	Speed: 65 MPH Dir: E		Veh Mnvr/Ped Actn:				4	Obj Strk:		44			
759	102791635	37.293	01/29/2010 21:57	REAR END, SLOW OR STOP	\$ 3500	0	0	0	1	5	5	4	1	0		
Unit	1 : 14	Alchl/Drgs:	0	Speed: 35 MPH Dir: W		Veh Mnvr/Ped Actn:				4	Obj Strk:					
Unit	2 : 1	Alchl/Drgs:	0	Speed: 35 MPH Dir: W		Veh Mnvr/Ped Actn:				4	Obj Strk:					

**North Carolina Department of Transportation
Traffic Engineering Accident Analysis System
Strip Analysis Report**

Acc No	Crash ID	Milepost	Date	Accident Type	Total Damage	Injuries				Condition			Road		Trfc Ctl	
						F	A	B	C	R	L	W	Ch	Ci	Dv	Op
760	102957265	37.293	09/07/2010 18:41	SIDESWIPE, SAME DIRECTION	\$ 3500	0	0	0	0	1	1	1	5	0	0	
Unit	1 : 14	Alchl/Drgs:	0	Speed: 60 MPH Dir: E		Veh Mnvr/Ped Actn:				5	Obj Strk:					
Unit	2 : 5	Alchl/Drgs:	0	Speed: 60 MPH Dir: E		Veh Mnvr/Ped Actn:				4	Obj Strk:					
761	103119053	37.293	03/23/2011 16:40	MOVABLE OBJECT	\$ 4900	0	0	0	0	1	1	1	1	0	0	
Unit	1 : 14	Alchl/Drgs:	0	Speed: 65 MPH Dir: E		Veh Mnvr/Ped Actn:				4	Obj Strk:					
Unit	2 : 10	Alchl/Drgs:	0	Speed: 65 MPH Dir: E		Veh Mnvr/Ped Actn:				4	Obj Strk:		18			
Unit	3 : 1	Alchl/Drgs:	0	Speed: 65 MPH Dir: E		Veh Mnvr/Ped Actn:				4	Obj Strk:		18			
Unit	4 : 1	Alchl/Drgs:	0	Speed: 65 MPH Dir: E		Veh Mnvr/Ped Actn:				4	Obj Strk:		18			
Unit	5 : 1	Alchl/Drgs:	0	Speed: 65 MPH Dir: E		Veh Mnvr/Ped Actn:				4	Obj Strk:		18			
Unit	6 : 2	Alchl/Drgs:	0	Speed: 65 MPH Dir: E		Veh Mnvr/Ped Actn:				4	Obj Strk:		18			
762	103125969	37.293	04/01/2011 16:16	SIDESWIPE, SAME DIRECTION	\$ 1300	0	0	0	0	1	1	1	1	0	0	
Unit	1 : 2	Alchl/Drgs:	0	Speed: 65 MPH Dir: W		Veh Mnvr/Ped Actn:				5	Obj Strk:					
Unit	2 : 1	Alchl/Drgs:	0	Speed: 65 MPH Dir: W		Veh Mnvr/Ped Actn:				4	Obj Strk:					
763	103366441	37.393	01/31/2012 15:36	FIXED OBJECT	\$ 2100	0	0	0	0	1	1	1	1	0	0	
Unit	1 : 1	Alchl/Drgs:	0	Speed: 65 MPH Dir: W		Veh Mnvr/Ped Actn:				4	Obj Strk:		44			
764	102937163	37.427	08/13/2010 11:12	REAR END, SLOW OR STOP	\$ 10000	0	0	0	0	1	1	1	1	0	0	
Unit	1 : 1	Alchl/Drgs:	0	Speed: 65 MPH Dir: E		Veh Mnvr/Ped Actn:				4	Obj Strk:					
Unit	2 : 1	Alchl/Drgs:	0	Speed: 60 MPH Dir: E		Veh Mnvr/Ped Actn:				4	Obj Strk:					
765	102926201	37.486	07/30/2010 09:08	FIXED OBJECT	\$ 3400	0	0	0	0	1	1	1	1	0	0	
Unit	1 : 3	Alchl/Drgs:	0	Speed: 65 MPH Dir: W		Veh Mnvr/Ped Actn:				4	Obj Strk:		44			
766	102653823	37.493	08/09/2009 23:03	REAR END, SLOW OR STOP	\$ 4000	0	0	0	0	1	5	1	1	0	0	
Unit	1 : 1	Alchl/Drgs:	0	Speed: 30 MPH Dir: E		Veh Mnvr/Ped Actn:				4	Obj Strk:					
Unit	2 : 1	Alchl/Drgs:	0	Speed: 30 MPH Dir: E		Veh Mnvr/Ped Actn:				11	Obj Strk:					
767	103051133	37.493	12/25/2010 01:50	REAR END, SLOW OR STOP	\$ 3000	0	0	0	0	5	1	4	1	0	0	
Unit	1 : 5	Alchl/Drgs:	0	Speed: 30 MPH Dir: E		Veh Mnvr/Ped Actn:				4	Obj Strk:					
Unit	2 : 4	Alchl/Drgs:	7	Speed: 40 MPH Dir: E		Veh Mnvr/Ped Actn:				4	Obj Strk:					
768	103420155	37.493	04/08/2012 10:10	SIDESWIPE, SAME DIRECTION	\$ 4500	0	0	1	0	9	1	1	1	0	0	
Unit	1 : 4	Alchl/Drgs:	0	Speed: 60 MPH Dir: W		Veh Mnvr/Ped Actn:				5	Obj Strk:					
Unit	2 : 1	Alchl/Drgs:	0	Speed: 55 MPH Dir: W		Veh Mnvr/Ped Actn:				4	Obj Strk:		59			

**North Carolina Department of Transportation
Traffic Engineering Accident Analysis System
Strip Analysis Report**

Acc No	Crash ID	Milepost	Date	Accident Type	Total Damage	Injuries				Condition			Road		Trfc Ctl	
						F	A	B	C	R	L	W	Ch	Ci	Dv	Op
769	103269919	37.593	10/09/2011 16:17	FIXED OBJECT	\$ 3500	0	0	0	0	1	1	1	5	0	0	
Unit	1 : 1	Alchl/Drgs:	0	Speed:	65 MPH	Dir:	N	Veh Mnvr/Ped Actn:				4	Obj Strk:		59	
770	103189842	37.693	06/30/2011 14:16	FIXED OBJECT	\$ 6000	0	1	0	0	1	1	1	1	0	0	
Unit	1 : 2	Alchl/Drgs:	0	Speed:	65 MPH	Dir:	W	Veh Mnvr/Ped Actn:				4	Obj Strk:		44	
771	103437451	37.893	04/17/2012 10:13	SIDESWIPE, SAME DIRECTION	\$ 300	0	0	0	0	1	1	1	1	0	0	
Unit	1 : 2	Alchl/Drgs:	0	Speed:	65 MPH	Dir:	SE	Veh Mnvr/Ped Actn:				4	Obj Strk:			
Unit	2 : 4	Alchl/Drgs:	7	Speed:	70 MPH	Dir:	SE	Veh Mnvr/Ped Actn:				6	Obj Strk:			
772	103170318	37.993	06/03/2011 15:00	FIXED OBJECT	\$ 2000	0	0	0	0	1	1	1	1	0	0	
Unit	1 : 1	Alchl/Drgs:	0	Speed:	65 MPH	Dir:	W	Veh Mnvr/Ped Actn:				4	Obj Strk:		44	
773	103237124	37.993	08/27/2011 22:00	SIDESWIPE, SAME DIRECTION	\$ 6000	0	0	0	3	1	5	1	1	0	0	
Unit	1 : 2	Alchl/Drgs:	3	Speed:	75 MPH	Dir:	E	Veh Mnvr/Ped Actn:				4	Obj Strk:			
Unit	2 : 4	Alchl/Drgs:	0	Speed:	60 MPH	Dir:	E	Veh Mnvr/Ped Actn:				4	Obj Strk:			
774	102695098	38.093	10/01/2009 11:38	SIDESWIPE, SAME DIRECTION	\$ 650	0	0	0	0	1	1	1	7	0	0	
Unit	1 : 1	Alchl/Drgs:	0	Speed:	55 MPH	Dir:	E	Veh Mnvr/Ped Actn:				5	Obj Strk:			
Unit	2 : 1	Alchl/Drgs:	0	Speed:	55 MPH	Dir:	E	Veh Mnvr/Ped Actn:				4	Obj Strk:			
775	102748673	38.093	12/19/2009 08:35	OVERTURN/ROLLOVER	\$ 4500	0	0	0	1	5	1	2	1	1	0	
Unit	1 : 1	Alchl/Drgs:	0	Speed:	60 MPH	Dir:	W	Veh Mnvr/Ped Actn:				4	Obj Strk:			
776	102756622	38.093	12/29/2009 13:01	REAR END, SLOW OR STOP	\$ 800	0	0	0	0	1	1	1	1	0	0	
Unit	1 : 2	Alchl/Drgs:	0	Speed:	65 MPH	Dir:	W	Veh Mnvr/Ped Actn:				4	Obj Strk:			
Unit	2 : 32	Alchl/Drgs:	7	Speed:	35 MPH	Dir:	W	Veh Mnvr/Ped Actn:				5	Obj Strk:			
777	102993228	38.093	10/22/2010 19:24	SIDESWIPE, SAME DIRECTION	\$ 3200	0	0	0	0	1	5	1	1	0	0	
Unit	1 : 14	Alchl/Drgs:	0	Speed:	5 MPH	Dir:	NW	Veh Mnvr/Ped Actn:				4	Obj Strk:			
Unit	2 : 1	Alchl/Drgs:	0	Speed:	5 MPH	Dir:	NW	Veh Mnvr/Ped Actn:				5	Obj Strk:			
778	103050922	38.093	12/25/2010 02:00	FIXED OBJECT	\$ 2150	0	0	0	0	5	1	4	1	0	0	
Unit	1 : 2	Alchl/Drgs:	0	Speed:	35 MPH	Dir:	E	Veh Mnvr/Ped Actn:				4	Obj Strk:		42	

**North Carolina Department of Transportation
Traffic Engineering Accident Analysis System
Strip Analysis Report**

Acc No	Crash ID	Milepost	Date	Accident Type	Total Damage	Injuries				Condition			Road		Trfc Ctl	
						F	A	B	C	R	L	W	Ch	Ci	Dv	Op
779	103156857	38.093	05/15/2011 16:15	SIDESWIPE, SAME DIRECTION	\$ 3500	0	0	0	0	1	1	1	1	0	0	
Unit	1 : 4	Alchl/Drgs:	0	Speed: 65 MPH Dir: W		Veh Mnvr/Ped Actn:				5	Obj Strk:					
Unit	2 : 1	Alchl/Drgs:	0	Speed: 65 MPH Dir: W		Veh Mnvr/Ped Actn:				4	Obj Strk:					

780	103191451	38.093	07/01/2011 16:00	MOVABLE OBJECT	\$ 1700	0	0	0	0	1	1	1	1	0	0	
Unit	1 : 2	Alchl/Drgs:	0	Speed: 60 MPH Dir: W		Veh Mnvr/Ped Actn:				4	Obj Strk:					
Unit	2 : 1	Alchl/Drgs:	0	Speed: 60 MPH Dir: W		Veh Mnvr/Ped Actn:				4	Obj Strk:		18			
Unit	3 : 1	Alchl/Drgs:	0	Speed: 60 MPH Dir: W		Veh Mnvr/Ped Actn:				4	Obj Strk:		18			

781	102832732	38.149	03/29/2010 18:17	REAR END, SLOW OR STOP	\$ 5500	0	0	0	0	1	1	1	1	0	0	
Unit	1 : 10	Alchl/Drgs:	0	Speed: 55 MPH Dir: S		Veh Mnvr/Ped Actn:				4	Obj Strk:					
Unit	2 : 1	Alchl/Drgs:	0	Speed: 55 MPH Dir: S		Veh Mnvr/Ped Actn:				11	Obj Strk:					

782	102971405	38.167	09/26/2010 20:03	ANGLE	\$ 16750	0	0	2	2	3	5	3	1	0	2	1
Unit	1 : 14	Alchl/Drgs:	0	Speed: 55 MPH Dir: SE		Veh Mnvr/Ped Actn:				4	Obj Strk:					
Unit	2 : 1	Alchl/Drgs:	0	Speed: 55 MPH Dir: SE		Veh Mnvr/Ped Actn:				4	Obj Strk:					
Unit	3 : 1	Alchl/Drgs:	0	Speed: 45 MPH Dir: NE		Veh Mnvr/Ped Actn:				5	Obj Strk:					

783	103078504	38.193	01/29/2011 19:57	ANIMAL	\$ 7000	0	0	0	0	1	5	1	1	0	0	
Unit	1 : 4	Alchl/Drgs:	0	Speed: 60 MPH Dir: SE		Veh Mnvr/Ped Actn:				4	Obj Strk:		17			

784	103269718	38.193	10/08/2011 09:55	SIDESWIPE, SAME DIRECTION	\$ 5400	0	0	0	0	1	1	1	1	0	0	
Unit	1 : 3	Alchl/Drgs:	0	Speed: 55 MPH Dir: E		Veh Mnvr/Ped Actn:				5	Obj Strk:					
Unit	2 : 1	Alchl/Drgs:	0	Speed: 55 MPH Dir: E		Veh Mnvr/Ped Actn:				4	Obj Strk:					

785	103334218	38.193	12/20/2011 18:50	ANGLE	\$ 8000	0	0	0	1	2	5	3	1	0	0	
Unit	1 : 1	Alchl/Drgs:	0	Speed: 65 MPH Dir: E		Veh Mnvr/Ped Actn:				4	Obj Strk:					
Unit	2 : 1	Alchl/Drgs:	1	Speed: 50 MPH Dir: E		Veh Mnvr/Ped Actn:				5	Obj Strk:					

786	102791535	38.203	02/14/2010 04:07	FIXED OBJECT	\$ 9600	0	0	2	0	2	5	1	1	0	0	
Unit	1 : 4	Alchl/Drgs:	1	Speed: 80 MPH Dir: E		Veh Mnvr/Ped Actn:				4	Obj Strk:		44			

787	103504877	38.203	07/23/2012 21:33	SIDESWIPE, SAME DIRECTION	\$ 2000	0	0	0	0	1	5	1	1	0	0	
Unit	1 : 2	Alchl/Drgs:	0	Speed: 60 MPH Dir: E		Veh Mnvr/Ped Actn:				4	Obj Strk:					
Unit	2 : 5	Alchl/Drgs:	0	Speed: 60 MPH Dir: E		Veh Mnvr/Ped Actn:				4	Obj Strk:					

**North Carolina Department of Transportation
Traffic Engineering Accident Analysis System
Strip Analysis Report**

Acc No	Crash ID	Milepost	Date	Accident Type	Total Damage	Injuries				Condition			Road		Trfc Ctl	
						F	A	B	C	R	L	W	Ch	Ci	Dv	Op
788	102677930	38.231	09/07/2009 17:47	REAR END, SLOW OR STOP	\$ 39800	0	0	0	2	2	1	3	1	0		
Unit	1 : 4	Alchl/Drgs:	0	Speed:	60 MPH Dir: N	Veh Mnvr/Ped Actn:				4	Obj Strk:					
Unit	2 : 2	Alchl/Drgs:	0	Speed:	60 MPH Dir: N	Veh Mnvr/Ped Actn:				4	Obj Strk:					
Unit	3 : 4	Alchl/Drgs:	0	Speed:	25 MPH Dir: N	Veh Mnvr/Ped Actn:				11	Obj Strk:		44			
Unit	4 : 1	Alchl/Drgs:	0	Speed:	25 MPH Dir: N	Veh Mnvr/Ped Actn:				11	Obj Strk:		44			

789	103229766	38.238	07/30/2011 02:11	RAN OFF ROAD - LEFT	\$ 14000	1	0	2	0	1	5	1	5	0	0	
Unit	1 : 4	Alchl/Drgs:	1	Speed:	65 MPH Dir: NE	Veh Mnvr/Ped Actn:				4	Obj Strk:		42			

790	103042733	38.288	12/04/2010 13:59	REAR END, SLOW OR STOP	\$ 45500	0	0	0	1	2	1	3	1	0	0	
Unit	1 : 14	Alchl/Drgs:	0	Speed:	65 MPH Dir: E	Veh Mnvr/Ped Actn:				4	Obj Strk:					
Unit	2 : 1	Alchl/Drgs:	0	Speed:	65 MPH Dir: E	Veh Mnvr/Ped Actn:				11	Obj Strk:					
Unit	3 : 14	Alchl/Drgs:	0	Speed:	65 MPH Dir: E	Veh Mnvr/Ped Actn:				11	Obj Strk:					
Unit	4 : 1	Alchl/Drgs:	0	Speed:	65 MPH Dir: E	Veh Mnvr/Ped Actn:				11	Obj Strk:					

791	102669364	38.293	09/05/2009 12:09	REAR END, SLOW OR STOP	\$ 3200	0	0	0	0	1	1	1	1	0	0	
Unit	1 : 1	Alchl/Drgs:	0	Speed:	65 MPH Dir: W	Veh Mnvr/Ped Actn:				4	Obj Strk:					
Unit	2 : 4	Alchl/Drgs:	0	Speed:	65 MPH Dir: W	Veh Mnvr/Ped Actn:				11	Obj Strk:					

792	102822401	38.293	03/16/2010 11:25	SIDESWIPE, SAME DIRECTION	\$ 55	0	0	0	0	1	1	1	1	0	0	
Unit	1 : 14	Alchl/Drgs:	0	Speed:	65 MPH Dir: SE	Veh Mnvr/Ped Actn:				4	Obj Strk:					
Unit	2 : 1	Alchl/Drgs:	0	Speed:	60 MPH Dir: SE	Veh Mnvr/Ped Actn:				4	Obj Strk:					

793	102833360	38.293	04/01/2010 06:07	REAR END, SLOW OR STOP	\$ 2800	0	0	0	0	1	5	1	1	0	0	
Unit	1 : 2	Alchl/Drgs:	0	Speed:	58 MPH Dir: SE	Veh Mnvr/Ped Actn:				4	Obj Strk:					
Unit	2 : 1	Alchl/Drgs:	0	Speed:	70 MPH Dir: SE	Veh Mnvr/Ped Actn:				4	Obj Strk:					

794	102891993	38.293	06/19/2010 13:10	REAR END, SLOW OR STOP	\$ 7000	0	0	0	0	1	1	1	1	0	0	
Unit	1 : 1	Alchl/Drgs:	0	Speed:	65 MPH Dir: W	Veh Mnvr/Ped Actn:				1	Obj Strk:					
Unit	2 : 4	Alchl/Drgs:	0	Speed:	65 MPH Dir: W	Veh Mnvr/Ped Actn:				11	Obj Strk:					
Unit	3 : 14	Alchl/Drgs:	0	Speed:	65 MPH Dir: W	Veh Mnvr/Ped Actn:				4	Obj Strk:					

795	102892042	38.293	06/19/2010 13:50	REAR END, SLOW OR STOP	\$ 5800	0	0	0	1	1	1	1	1	0	0	
Unit	1 : 1	Alchl/Drgs:	0	Speed:	45 MPH Dir: W	Veh Mnvr/Ped Actn:				4	Obj Strk:					
Unit	2 : 2	Alchl/Drgs:	0	Speed:	45 MPH Dir: W	Veh Mnvr/Ped Actn:				11	Obj Strk:					

796	103241764	38.293	09/03/2011 11:43	REAR END, SLOW OR STOP	\$ 4502	0	0	0	0	1	1	1	1	0	0	
Unit	1 : 1	Alchl/Drgs:	0	Speed:	60 MPH Dir: W	Veh Mnvr/Ped Actn:				4	Obj Strk:					

**North Carolina Department of Transportation
Traffic Engineering Accident Analysis System
Strip Analysis Report**

Acc No	Crash ID	Milepost	Date	Accident Type	Total Damage	Injuries				Condition			Road		Trfc Ctl	
						F	A	B	C	R	L	W	Ch	Ci	Dv	Op
Unit	2 : 1	Alchl/Drgs:	0	Speed:	60 MPH Dir: W	Veh Mnvr/Ped Actn:				11	Obj Strk:					
797	103420159	38.293	04/08/2012 10:40	REAR END, SLOW OR STOP	\$ 3200	0	0	0	0	1	1	1	1	0	0	
Unit	1 : 1	Alchl/Drgs:	0	Speed:	20 MPH Dir: W	Veh Mnvr/Ped Actn:				4	Obj Strk:					
Unit	2 : 1	Alchl/Drgs:	0	Speed:	45 MPH Dir: W	Veh Mnvr/Ped Actn:				4	Obj Strk:					
798	103471075	38.293	06/09/2012 17:08	SIDESWIPE, SAME DIRECTION	\$ 4500	0	0	0	0	1	1	1	1	0	0	
Unit	1 : 4	Alchl/Drgs:	0	Speed:	55 MPH Dir: E	Veh Mnvr/Ped Actn:				5	Obj Strk:					
Unit	2 : 1	Alchl/Drgs:	0	Speed:	60 MPH Dir: E	Veh Mnvr/Ped Actn:				4	Obj Strk:					
799	102652189	38.393	08/12/2009 18:56	FIXED OBJECT	\$ 3500	0	0	0	1	1	1	1	7	0	0	
Unit	1 : 1	Alchl/Drgs:	1	Speed:	50 MPH Dir: N	Veh Mnvr/Ped Actn:				4	Obj Strk: 41					
800	102811780	38.393	03/09/2010 13:40	REAR END, SLOW OR STOP	\$ 200	0	0	0	0	1	1	1	1	0	0	
Unit	1 : 14	Alchl/Drgs:	0	Speed:	60 MPH Dir: E	Veh Mnvr/Ped Actn:				4	Obj Strk:					
Unit	2 : 4	Alchl/Drgs:	0	Speed:	40 MPH Dir: E	Veh Mnvr/Ped Actn:				4	Obj Strk:					
801	103059268	38.393	12/12/2010 08:37	FIXED OBJECT	\$ 1500	0	0	0	0	5	1	4	1	0	0	
Unit	1 : 4	Alchl/Drgs:	0	Speed:	60 MPH Dir: W	Veh Mnvr/Ped Actn:				4	Obj Strk: 33					
802	102705536	38.486	10/16/2009 07:08	MOVABLE OBJECT	\$ 3600	0	0	0	0	1	5	1	1	0	0	
Unit	1 : 14	Alchl/Drgs:	0	Speed:	65 MPH Dir: E	Veh Mnvr/Ped Actn:				4	Obj Strk:					
Unit	2 : 2	Alchl/Drgs:	0	Speed:	65 MPH Dir: E	Veh Mnvr/Ped Actn:				4	Obj Strk:					
803	103476067	38.593	06/14/2012 17:13	FIXED OBJECT	\$ 8000	0	0	1	0	1	1	1	1	0	0	
Unit	1 : 1	Alchl/Drgs:	3	Speed:	70 MPH Dir: E	Veh Mnvr/Ped Actn:				4	Obj Strk: 44					
804	103454485	38.686	05/20/2012 15:50	REAR END, SLOW OR STOP	\$ 1700	0	0	0	0	1	1	1	1	0	0	
Unit	1 : 2	Alchl/Drgs:	0	Speed:	65 MPH Dir: E	Veh Mnvr/Ped Actn:				4	Obj Strk:					
Unit	2 : 1	Alchl/Drgs:	0	Speed:	65 MPH Dir: E	Veh Mnvr/Ped Actn:				4	Obj Strk:					
805	102993235	38.693	10/10/2010 02:10	MOVABLE OBJECT	\$ 1100	0	0	0	0	1	5	1	1	2	0	
Unit	1 : 1	Alchl/Drgs:	0	Speed:	60 MPH Dir: SE	Veh Mnvr/Ped Actn:				4	Obj Strk: 18					
806	103258735	38.893	09/23/2011 17:30	FIXED OBJECT	\$ 3800	0	0	0	0	1	1	1	1	0	0	
Unit	1 : 2	Alchl/Drgs:	0	Speed:	60 MPH Dir: E	Veh Mnvr/Ped Actn:				4	Obj Strk: 44					

**North Carolina Department of Transportation
Traffic Engineering Accident Analysis System
Strip Analysis Report**

Acc No	Crash ID	Milepost	Date	Accident Type	Total Damage	Injuries				Condition			Road		Trfc Ctl		
						F	A	B	C	R	L	W	Ch	Ci	Dv	Op	
807	103069048	38.993	01/18/2011 06:58	SIDESWIPE, SAME DIRECTION	\$ 4100	0	0	0	0	2	5	2	1	0	0		
Unit	1 : 10	Alchl/Drgs:	0	Speed: 65 MPH Dir: S		Veh Mnvr/Ped Actn:				5	Obj Strk:						
Unit	2 : 1	Alchl/Drgs:	0	Speed: 65 MPH Dir: S		Veh Mnvr/Ped Actn:				4	Obj Strk:						
808	102898766	39.093	06/27/2010 07:40	RAN OFF ROAD - RIGHT	\$ 30000	0	0	0	0	1	1	1	1	0	0		
Unit	1 : 2	Alchl/Drgs:	0	Speed: 50 MPH Dir: E		Veh Mnvr/Ped Actn:				4	Obj Strk:		59				
809	102656178	39.193	08/19/2009 21:05	OTHER COLLISION WITH VEHICLE	\$ 100	0	0	0	0	2	5	1	1	0	0		
Unit	1 : 14	Alchl/Drgs:	0	Speed: 65 MPH Dir: W		Veh Mnvr/Ped Actn:				4	Obj Strk:						
Unit	2 : 32	Alchl/Drgs:	7	Speed: 60 MPH Dir: W		Veh Mnvr/Ped Actn:				16	Obj Strk:						
810	102808755	39.193	03/03/2010 15:25	OTHER COLLISION WITH VEHICLE	\$ 200	0	0	0	0	1	1	1	1	0	0		
Unit	1 : 2	Alchl/Drgs:	0	Speed: 65 MPH Dir: W		Veh Mnvr/Ped Actn:				4	Obj Strk:						
Unit	2 : 32	Alchl/Drgs:	7	Speed: 65 MPH Dir: W		Veh Mnvr/Ped Actn:				16	Obj Strk:						
811	102826278	39.264	03/29/2010 17:44	REAR END, SLOW OR STOP	\$ 16500	0	0	1	1	1	1	1	1	0	0		
Unit	1 : 1	Alchl/Drgs:	0	Speed: 65 MPH Dir: E		Veh Mnvr/Ped Actn:				4	Obj Strk:						
Unit	2 : 4	Alchl/Drgs:	0	Speed: 65 MPH Dir: E		Veh Mnvr/Ped Actn:				11	Obj Strk:						
812	103146175	39.586	04/30/2011 14:30	REAR END, SLOW OR STOP	\$ 1300	0	0	0	0	1	1	1	1	0	0		
Unit	1 : 4	Alchl/Drgs:	0	Speed: 65 MPH Dir: W		Veh Mnvr/Ped Actn:				4	Obj Strk:						
Unit	2 : 2	Alchl/Drgs:	0	Speed: 70 MPH Dir: W		Veh Mnvr/Ped Actn:				4	Obj Strk:						
813	103408612	39.746	03/22/2012 15:32	MOVABLE OBJECT	\$ 3700	0	0	0	0	1	1	1	1	2	0		
Unit	1 : 14	Alchl/Drgs:	0	Speed: 65 MPH Dir: NW		Veh Mnvr/Ped Actn:				4	Obj Strk:						
Unit	2 : 5	Alchl/Drgs:	0	Speed: 60 MPH Dir: NW		Veh Mnvr/Ped Actn:				15	Obj Strk:		18				
814	102784702	39.893	02/08/2010 01:37	RAN OFF ROAD - LEFT	\$ 5000	0	0	0	0	1	5	1	1	0	0		
Unit	1 : 14	Alchl/Drgs:	0	Speed: 65 MPH Dir: E		Veh Mnvr/Ped Actn:				4	Obj Strk:		44				
815	102987438	39.946	10/17/2010 16:38	REAR END, SLOW OR STOP	\$ 3500	0	0	0	0	1	1	1	1	0	0		
Unit	1 : 1	Alchl/Drgs:	0	Speed: 65 MPH Dir: E		Veh Mnvr/Ped Actn:				1	Obj Strk:						
Unit	2 : 1	Alchl/Drgs:	0	Speed: 65 MPH Dir: E		Veh Mnvr/Ped Actn:				4	Obj Strk:						
816	103208602	39.960	07/24/2011 16:41	MOVABLE OBJECT	\$ 1500	0	0	0	0	1	1	1	1	0	0		
Unit	1 : 2	Alchl/Drgs:	0	Speed: 60 MPH Dir: W		Veh Mnvr/Ped Actn:				4	Obj Strk:						
Unit	2 : 1	Alchl/Drgs:	0	Speed: 65 MPH Dir: W		Veh Mnvr/Ped Actn:				4	Obj Strk:		18				

**North Carolina Department of Transportation
Traffic Engineering Accident Analysis System
Strip Analysis Report**

Acc No	Crash ID	Milepost	Date	Accident Type	Total Damage	Injuries				Condition			Road		Trfc Ctl	
						F	A	B	C	R	L	W	Ch	Ci	Dv	Op
817	103303891	39.960	11/16/2011 08:00	FIXED OBJECT	\$ 3000	0	0	0	0	2	1	3	3	0	0	
Unit	1 : 1	Alchl/Drgs:	0	Speed:	65 MPH Dir: W	Veh Mnvr/Ped Actn:				4	Obj Strk:		44			
818	102958425	40.060	09/11/2010 07:53	FIXED OBJECT	\$ 4500	0	0	1	0	2	1	2	1	0	0	
Unit	1 : 1	Alchl/Drgs:	0	Speed:	80 MPH Dir: W	Veh Mnvr/Ped Actn:				4	Obj Strk:		44			
819	103103232	40.193	03/02/2011 14:12	OTHER NON-COLLISION	\$ 250	0	0	0	0	1	1	1	1	0	0	
Unit	1 : 11	Alchl/Drgs:	0	Speed:	55 MPH Dir: S	Veh Mnvr/Ped Actn:				4	Obj Strk:					
Unit	2 : 4	Alchl/Drgs:	0	Speed:	65 MPH Dir: S	Veh Mnvr/Ped Actn:				4	Obj Strk:					
820	103143177	40.193	04/25/2011 08:45	SIDESWIPE, SAME DIRECTION	\$ 2500	0	0	0	0	1	1	1	1	0	0	
Unit	1 : 4	Alchl/Drgs:	1	Speed:	65 MPH Dir: W	Veh Mnvr/Ped Actn:				5	Obj Strk:					
Unit	2 : 4	Alchl/Drgs:	0	Speed:	65 MPH Dir: W	Veh Mnvr/Ped Actn:				4	Obj Strk:					
821	103025809	40.194	11/24/2010 17:48	REAR END, SLOW OR STOP	\$ 4000	0	0	0	0	1	2	1	1	0	0	
Unit	1 : 1	Alchl/Drgs:	0	Speed:	60 MPH Dir: E	Veh Mnvr/Ped Actn:				11	Obj Strk:					
Unit	2 : 4	Alchl/Drgs:	0	Speed:	55 MPH Dir: E	Veh Mnvr/Ped Actn:				11	Obj Strk:					
822	103346974	40.240	01/05/2012 11:17	REAR END, SLOW OR STOP	\$ 5500	0	0	0	0	1	1	1	1	0	0	
Unit	1 : 1	Alchl/Drgs:	0	Speed:	65 MPH Dir: W	Veh Mnvr/Ped Actn:				4	Obj Strk:					
Unit	2 : 1	Alchl/Drgs:	0	Speed:	65 MPH Dir: W	Veh Mnvr/Ped Actn:				11	Obj Strk:					
823	103023425	40.260	11/24/2010 17:46	REAR END, SLOW OR STOP	\$ 14000	0	0	0	1	1	1	1	1	0	0	
Unit	1 : 4	Alchl/Drgs:	0	Speed:	65 MPH Dir: E	Veh Mnvr/Ped Actn:				1	Obj Strk:					
Unit	2 : 1	Alchl/Drgs:	0	Speed:	65 MPH Dir: E	Veh Mnvr/Ped Actn:				1	Obj Strk:					
Unit	3 : 1	Alchl/Drgs:	0	Speed:	65 MPH Dir: E	Veh Mnvr/Ped Actn:				1	Obj Strk:					
Unit	4 : 1	Alchl/Drgs:	0	Speed:	65 MPH Dir: E	Veh Mnvr/Ped Actn:				4	Obj Strk:					
824	102885107	40.271	06/10/2010 11:25	MOVABLE OBJECT	\$ 1050	0	0	1	0	1	1	1	1	2	0	
Unit	1 : 20	Alchl/Drgs:	0	Speed:	65 MPH Dir: W	Veh Mnvr/Ped Actn:				4	Obj Strk:		18			
825	103226615	40.286	08/13/2011 14:47	RAN OFF ROAD - LEFT	\$ 1200	0	0	0	0	1	1	2	5	0	0	
Unit	1 : 1	Alchl/Drgs:	0	Speed:	65 MPH Dir: W	Veh Mnvr/Ped Actn:				4	Obj Strk:		59			
826	103287600	40.360	10/28/2011 13:51	REAR END, SLOW OR STOP	\$ 1300	0	0	0	0	2	1	2	1	0	0	
Unit	1 : 5	Alchl/Drgs:	0	Speed:	15 MPH Dir: W	Veh Mnvr/Ped Actn:				4	Obj Strk:					

**North Carolina Department of Transportation
Traffic Engineering Accident Analysis System
Strip Analysis Report**

Acc No	Crash ID	Milepost	Date	Accident Type	Total Damage	Injuries				Condition			Road		Trfc Ctl	
						F	A	B	C	R	L	W	Ch	Ci	Dv	Op
Unit	2 : 4	Alchl/Drgs:	0	Speed:	10 MPH	Dir:	W	Veh Mnvr/Ped Actn:				1	Obj Strk:			
827	102675485	40.386	08/28/2009 16:22	MOVABLE OBJECT	\$ 1025	0	0	0	0	1	1	2	1	0	0	
Unit	1 : 2	Alchl/Drgs:	7	Speed:	65 MPH	Dir:	E	Veh Mnvr/Ped Actn:				4	Obj Strk: 18			
Unit	2 : 1	Alchl/Drgs:	0	Speed:	65 MPH	Dir:	E	Veh Mnvr/Ped Actn:				4	Obj Strk: 18			
828	102832396	40.440	04/05/2010 18:55	FIXED OBJECT	\$ 2500	0	0	0	1	2	1	3	3	0	0	
Unit	1 : 1	Alchl/Drgs:	0	Speed:	80 MPH	Dir:	N	Veh Mnvr/Ped Actn:				4	Obj Strk: 59			
829	102729487	40.460	11/24/2009 11:02	LEFT TURN, DIFFERENT ROADWAYS	\$ 27000	0	0	2	0	1	1	2	1	0	0	
Unit	1 : 2	Alchl/Drgs:	0	Speed:	65 MPH	Dir:	NW	Veh Mnvr/Ped Actn:				4	Obj Strk:			
Unit	2 : 1	Alchl/Drgs:	0	Speed:	35 MPH	Dir:	S	Veh Mnvr/Ped Actn:				8	Obj Strk:			
830	103025094	40.540	11/24/2010 17:46	REAR END, SLOW OR STOP	\$ 3100	0	0	0	0	1	5	1	1	0	0	
Unit	1 : 1	Alchl/Drgs:	0	Speed:	65 MPH	Dir:	E	Veh Mnvr/Ped Actn:				4	Obj Strk:			
Unit	2 : 2	Alchl/Drgs:	0	Speed:	65 MPH	Dir:	E	Veh Mnvr/Ped Actn:				1	Obj Strk:			
831	102963049	40.586	09/15/2010 12:35	FIXED OBJECT	\$ 850	0	0	0	0	1	1	1	1	0	0	
Unit	1 : 1	Alchl/Drgs:	0	Speed:	65 MPH	Dir:	W	Veh Mnvr/Ped Actn:				4	Obj Strk: 59			
832	102913030	40.640	07/15/2010 14:25	FIXED OBJECT	\$ 1900	0	0	0	0	1	1	1	1	0	0	
Unit	1 : 4	Alchl/Drgs:	0	Speed:	60 MPH	Dir:	S	Veh Mnvr/Ped Actn:				4	Obj Strk: 44			
833	102832199	40.660	04/01/2010 09:46	MOVABLE OBJECT	\$ 400	0	0	0	0	1	1	1	3	0	0	
Unit	1 : 14	Alchl/Drgs:	0	Speed:	60 MPH	Dir:	SE	Veh Mnvr/Ped Actn:				4	Obj Strk:			
Unit	2 : 1	Alchl/Drgs:	0	Speed:	65 MPH	Dir:	SE	Veh Mnvr/Ped Actn:				4	Obj Strk: 18			
834	103491711	40.740	07/06/2012 23:04	MOVABLE OBJECT	\$ 1000	0	0	0	0	1	5	1	1	0	0	
Unit	1 : 1	Alchl/Drgs:	0	Speed:	65 MPH	Dir:	E	Veh Mnvr/Ped Actn:				4	Obj Strk: 18			
835	103410046	40.746	03/22/2012 15:33	MOVABLE OBJECT	\$ 3700	0	0	0	0	1	1	1	1	2	0	
Unit	1 : 14	Alchl/Drgs:	0	Speed:	60 MPH	Dir:	NW	Veh Mnvr/Ped Actn:				4	Obj Strk:			
Unit	2 : 1	Alchl/Drgs:	0	Speed:	65 MPH	Dir:	NW	Veh Mnvr/Ped Actn:				4	Obj Strk: 18			
836	102698762	40.786	09/28/2009 11:40	REAR END, SLOW OR STOP	\$ 1250	0	0	0	0	1	1	1	1	0	0	
Unit	1 : 1	Alchl/Drgs:	0	Speed:	55 MPH	Dir:	W	Veh Mnvr/Ped Actn:				4	Obj Strk:			
Unit	2 : 5	Alchl/Drgs:	0	Speed:	55 MPH	Dir:	W	Veh Mnvr/Ped Actn:				4	Obj Strk:			

**North Carolina Department of Transportation
Traffic Engineering Accident Analysis System
Strip Analysis Report**

Acc No	Crash ID	Milepost	Date	Accident Type	Total Damage	Injuries				Condition			Road		Trfc Ctl	
						F	A	B	C	R	L	W	Ch	Ci	Dv	Op
837	103138546	40.786	04/17/2011 17:02	REAR END, SLOW OR STOP	\$ 7725	0	0	2	0	1	1	1	1	0	0	
Unit	1 : 20	Alchl/Drgs:	0	Speed: 150 MPH Dir: S		Veh Mnvr/Ped Actn:				16	Obj Strk:					
Unit	2 : 31	Alchl/Drgs:	0	Speed: 90 MPH Dir: S		Veh Mnvr/Ped Actn:				4	Obj Strk:					
838	103405457	40.836	03/16/2012 12:04	PARKED MOTOR VEHICLE	\$ 20000	0	1	0	0	1	1	1	1	0	0	
Unit	1 : 14	Alchl/Drgs:	7	Speed: 0 MPH Dir: W		Veh Mnvr/Ped Actn:				2	Obj Strk:		20			
Unit	2 : 1	Alchl/Drgs:	0	Speed: 65 MPH Dir: W		Veh Mnvr/Ped Actn:				4	Obj Strk:		20			
839	103234336	40.893	08/23/2011 19:40	FIXED OBJECT	\$ 20800	0	2	1	0	1	1	1	5	0	0	
Unit	1 : 1	Alchl/Drgs:	0	Speed: 70 MPH Dir: W		Veh Mnvr/Ped Actn:				4	Obj Strk:		44			
840	103461858	40.893	05/29/2012 13:02	REAR END, SLOW OR STOP	\$ 10500	0	0	0	0	1	1	1	5	0	0	
Unit	1 : 14	Alchl/Drgs:	0	Speed: 65 MPH Dir: W		Veh Mnvr/Ped Actn:				4	Obj Strk:					
Unit	2 : 2	Alchl/Drgs:	1	Speed: 70 MPH Dir: W		Veh Mnvr/Ped Actn:				4	Obj Strk:		44			
841	102800891	41.060	02/09/2010 19:50	ANIMAL	\$ 1500	0	0	0	0	1	5	1	1	0	0	
Unit	1 : 1	Alchl/Drgs:	0	Speed: 60 MPH Dir: W		Veh Mnvr/Ped Actn:				4	Obj Strk:		17			
842	103227817	41.060	08/12/2011 22:26	SIDESWIPE, SAME DIRECTION	\$ 3000	0	0	0	0	2	5	2	1	0	0	
Unit	1 : 3	Alchl/Drgs:	5	Speed: 60 MPH Dir: SE		Veh Mnvr/Ped Actn:				4	Obj Strk:					
Unit	2 : 2	Alchl/Drgs:	0	Speed: 55 MPH Dir: SE		Veh Mnvr/Ped Actn:				4	Obj Strk:					
843	102666228	41.176	09/02/2009 10:28	SIDESWIPE, SAME DIRECTION	\$ 4000	0	0	0	0	1	1	1	5	0	0	
Unit	1 : 5	Alchl/Drgs:	0	Speed: 65 MPH Dir: E		Veh Mnvr/Ped Actn:				4	Obj Strk:					
Unit	2 : 5	Alchl/Drgs:	0	Speed: 65 MPH Dir: E		Veh Mnvr/Ped Actn:				4	Obj Strk:					
844	102967173	41.193	09/22/2010 08:58	OTHER NON-COLLISION	\$ 2000	0	0	0	0	1	1	1	1	0	0	
Unit	1 : 14	Alchl/Drgs:	0	Speed: 60 MPH Dir: E		Veh Mnvr/Ped Actn:				4	Obj Strk:					
Unit	2 : 32	Alchl/Drgs:	7	Speed: 65 MPH Dir: E		Veh Mnvr/Ped Actn:				5	Obj Strk:					
Unit	3 : 1	Alchl/Drgs:	0	Speed: 65 MPH Dir: E		Veh Mnvr/Ped Actn:				4	Obj Strk:					
845	103059257	41.240	12/12/2010 02:00	RAN OFF ROAD - LEFT	\$ 2000	0	0	0	0	5	5	4	1	0	0	
Unit	1 : 4	Alchl/Drgs:	0	Speed: 45 MPH Dir: S		Veh Mnvr/Ped Actn:				4	Obj Strk:		44			
846	103179409	41.340	06/13/2011 16:48	SIDESWIPE, SAME DIRECTION	\$ 11800	0	0	0	0	1	1	1	1	0	0	
Unit	1 : 1	Alchl/Drgs:	0	Speed: 65 MPH Dir: W		Veh Mnvr/Ped Actn:				5	Obj Strk:					
Unit	2 : 1	Alchl/Drgs:	0	Speed: 65 MPH Dir: W		Veh Mnvr/Ped Actn:				4	Obj Strk:		42			

**North Carolina Department of Transportation
Traffic Engineering Accident Analysis System
Strip Analysis Report**

Acc No	Crash ID	Milepost	Date	Accident Type	Total Damage	Injuries				Condition			Road		Trfc Ctl	
						F	A	B	C	R	L	W	Ch	Ci	Dv	Op
Unit	3 : 2	Alchl/Drgs:	0	Speed:	65 MPH	Dir:	W	Veh Mnvr/Ped Actn:				4	Obj Strk:			
847	103292103	41.440	10/28/2011 16:59	REAR END, SLOW OR STOP	\$ 4500	0	0	0	0	1	1	2	1	0	0	
Unit	1 : 1	Alchl/Drgs:	0	Speed:	65 MPH	Dir:	W	Veh Mnvr/Ped Actn:				4	Obj Strk:			
Unit	2 : 1	Alchl/Drgs:	0	Speed:	65 MPH	Dir:	W	Veh Mnvr/Ped Actn:				11	Obj Strk:			
848	103391145	41.440	02/28/2012 05:17	FIXED OBJECT	\$ 4000	0	0	1	0	1	5	1	1	0	0	
Unit	1 : 1	Alchl/Drgs:	0	Speed:	70 MPH	Dir:	W	Veh Mnvr/Ped Actn:				4	Obj Strk:			
849	103497359	41.440	07/13/2012 18:25	MOVABLE OBJECT	\$ 1500	0	0	0	0	2	1	2	1	2	0	
Unit	1 : 1	Alchl/Drgs:	0	Speed:	55 MPH	Dir:	E	Veh Mnvr/Ped Actn:				4	Obj Strk: 18			
850	102860751	41.540	05/11/2010 19:39	FIXED OBJECT	\$ 1800	0	0	0	0	2	2	2	1	0	0	
Unit	1 : 1	Alchl/Drgs:	0	Speed:	65 MPH	Dir:	W	Veh Mnvr/Ped Actn:				4	Obj Strk: 44			
851	103025073	41.540	11/11/2010 19:08	SIDESWIPE, SAME DIRECTION	\$ 6000	0	0	0	0	1	5	1	1	0	0	
Unit	1 : 14	Alchl/Drgs:	0	Speed:	65 MPH	Dir:	W	Veh Mnvr/Ped Actn:				4	Obj Strk:			
Unit	2 : 4	Alchl/Drgs:	0	Speed:	60 MPH	Dir:	W	Veh Mnvr/Ped Actn:				5	Obj Strk:			
852	103059330	41.586	01/04/2011 20:32	SIDESWIPE, SAME DIRECTION	\$ 900	0	0	0	0	1	5	1	1	0	0	
Unit	1 : 1	Alchl/Drgs:	0	Speed:	65 MPH	Dir:	E	Veh Mnvr/Ped Actn:				4	Obj Strk:			
Unit	2 : 1	Alchl/Drgs:	0	Speed:	65 MPH	Dir:	E	Veh Mnvr/Ped Actn:				4	Obj Strk:			
853	102799654	41.640	02/23/2010 08:44	SIDESWIPE, SAME DIRECTION	\$ 4500	0	0	0	0	1	1	1	1	0	0	
Unit	1 : 14	Alchl/Drgs:	0	Speed:	60 MPH	Dir:	W	Veh Mnvr/Ped Actn:				4	Obj Strk:			
Unit	2 : 1	Alchl/Drgs:	0	Speed:	65 MPH	Dir:	W	Veh Mnvr/Ped Actn:				5	Obj Strk:			
854	102868317	41.640	05/20/2010 14:18	MOVABLE OBJECT	\$ 1200	0	0	0	0	1	1	1	1	0	0	
Unit	1 : 10	Alchl/Drgs:	0	Speed:	55 MPH	Dir:	E	Veh Mnvr/Ped Actn:				4	Obj Strk: 18			
855	102952718	41.640	09/02/2010 11:00	REAR END, SLOW OR STOP	\$ 16900	0	0	1	2	1	1	1	1	0	0	
Unit	1 : 2	Alchl/Drgs:	0	Speed:	60 MPH	Dir:	W	Veh Mnvr/Ped Actn:				4	Obj Strk:			
Unit	2 : 5	Alchl/Drgs:	0	Speed:	60 MPH	Dir:	W	Veh Mnvr/Ped Actn:				11	Obj Strk:			
Unit	3 : 2	Alchl/Drgs:	0	Speed:	45 MPH	Dir:	W	Veh Mnvr/Ped Actn:				1	Obj Strk:			
856	103139202	41.640	04/16/2011 12:10	MOVABLE OBJECT	\$ 3500	0	0	0	0	1	1	1	1	2	0	
Unit	1 : 2	Alchl/Drgs:	0	Speed:	60 MPH	Dir:	N	Veh Mnvr/Ped Actn:				4	Obj Strk: 18			

**North Carolina Department of Transportation
Traffic Engineering Accident Analysis System
Strip Analysis Report**

Acc No	Crash ID	Milepost	Date	Accident Type	Total Damage	Injuries				Condition			Road		Trfc Ctl	
						F	A	B	C	R	L	W	Ch	Ci	Dv	Op
857	103287277	41.640	10/27/2011 14:55	FIXED OBJECT	\$ 2100	0	0	0	0	1	1	1	1	0	0	
Unit	1 : 1	Alchl/Drgs:	0	Speed:	60 MPH	Dir:	NW	Veh Mnvr/Ped Actn:				4	Obj Strk:	44		
Unit	2 : 1	Alchl/Drgs:	7	Speed:	65 MPH	Dir:	NW	Veh Mnvr/Ped Actn:				5	Obj Strk:			
858	102912757	41.683	07/10/2010 13:38	REAR END, SLOW OR STOP	\$ 4300	0	0	0	0	1	1	1	1	0	0	
Unit	1 : 1	Alchl/Drgs:	0	Speed:	20 MPH	Dir:	NW	Veh Mnvr/Ped Actn:				4	Obj Strk:	44		
Unit	2 : 4	Alchl/Drgs:	0	Speed:	0 MPH	Dir:	NW	Veh Mnvr/Ped Actn:				1	Obj Strk:			
859	103194536	41.740	07/07/2011 09:12	FIXED OBJECT	\$ 400	0	0	0	0	1	1	1	1	0	0	
Unit	1 : 10	Alchl/Drgs:	0	Speed:	65 MPH	Dir:	W	Veh Mnvr/Ped Actn:				4	Obj Strk:			
Unit	2 : 1	Alchl/Drgs:	0	Speed:	65 MPH	Dir:	W	Veh Mnvr/Ped Actn:				4	Obj Strk:	46		
860	103419851	41.740	04/06/2012 11:16	REAR END, SLOW OR STOP	\$ 4000	0	0	0	2	1	1	2	1	4	0	
Unit	1 : 5	Alchl/Drgs:	0	Speed:	55 MPH	Dir:	E	Veh Mnvr/Ped Actn:				4	Obj Strk:			
Unit	2 : 2	Alchl/Drgs:	0	Speed:	50 MPH	Dir:	E	Veh Mnvr/Ped Actn:				11	Obj Strk:			
861	103427118	41.740	04/14/2012 19:15	MOVABLE OBJECT	\$ 100	0	0	0	0	1	1	1	1	4	0	
Unit	1 : 10	Alchl/Drgs:	0	Speed:	60 MPH	Dir:	SE	Veh Mnvr/Ped Actn:				4	Obj Strk:	18		
862	102789185	41.759	02/11/2010 10:15	ANIMAL	\$ 950	0	0	0	0	1	1	1	1	0	0	
Unit	1 : 1	Alchl/Drgs:	0	Speed:	65 MPH	Dir:	E	Veh Mnvr/Ped Actn:				4	Obj Strk:	17		
863	103448937	41.786	05/11/2012 19:56	REAR END, SLOW OR STOP	\$ 12000	0	0	1	1	1	1	1	1	0	0	
Unit	1 : 1	Alchl/Drgs:	0	Speed:	120 MPH	Dir:	E	Veh Mnvr/Ped Actn:				5	Obj Strk:			
Unit	2 : 5	Alchl/Drgs:	0	Speed:	55 MPH	Dir:	E	Veh Mnvr/Ped Actn:				4	Obj Strk:			
864	103200588	41.806	07/11/2011 11:18	SIDESWIPE, SAME DIRECTION	\$ 6800	0	0	0	1	1	1	1	1	0	0	
Unit	1 : 14	Alchl/Drgs:	0	Speed:	55 MPH	Dir:	W	Veh Mnvr/Ped Actn:				5	Obj Strk:			
Unit	2 : 1	Alchl/Drgs:	0	Speed:	60 MPH	Dir:	W	Veh Mnvr/Ped Actn:				4	Obj Strk:	46		
865	102808831	41.840	03/05/2010 18:11	ANIMAL	\$ 2500	0	0	0	0	1	5	1	1	0	0	
Unit	1 : 1	Alchl/Drgs:	0	Speed:	60 MPH	Dir:	W	Veh Mnvr/Ped Actn:				4	Obj Strk:	17		
866	102881841	41.840	06/06/2010 13:27	MOVABLE OBJECT	\$ 1400	0	0	0	0	1	1	1	1	0	0	
Unit	1 : 2	Alchl/Drgs:	0	Speed:	65 MPH	Dir:	S	Veh Mnvr/Ped Actn:				4	Obj Strk:	18		
Unit	2 : 1	Alchl/Drgs:	0	Speed:	65 MPH	Dir:	S	Veh Mnvr/Ped Actn:				4	Obj Strk:	18		

**North Carolina Department of Transportation
Traffic Engineering Accident Analysis System
Strip Analysis Report**

Acc No	Crash ID	Milepost	Date	Accident Type	Total Damage	Injuries				Condition			Road		Trfc Ctl	
						F	A	B	C	R	L	W	Ch	Ci	Dv	Op
867	102875260	41.940	05/19/2010 09:50	MOVABLE OBJECT	\$ 500	0	0	0	0	1	1	1	3	0	0	
Unit	1 : 5	Alchl/Drgs:	0	Speed:	60 MPH	Dir:	E	Veh Mnvr/Ped Actn:				4	Obj Strk:			
Unit	2 : 14	Alchl/Drgs:	7	Speed:	60 MPH	Dir:	E	Veh Mnvr/Ped Actn:				4	Obj Strk:			
868	103431809	42.086	04/20/2012 17:45	SIDESWIPE, SAME DIRECTION	\$ 1600	0	0	0	0	1	1	1	1	0	0	
Unit	1 : 5	Alchl/Drgs:	0	Speed:	60 MPH	Dir:	W	Veh Mnvr/Ped Actn:				4	Obj Strk:			
Unit	2 : 1	Alchl/Drgs:	0	Speed:	50 MPH	Dir:	W	Veh Mnvr/Ped Actn:				4	Obj Strk:			
869	103508019	42.093	07/27/2012 11:26	RAN OFF ROAD - RIGHT	\$ 90000	0	0	0	0	1	1	1	1	0	0	
Unit	1 : 12	Alchl/Drgs:	0	Speed:	65 MPH	Dir:	E	Veh Mnvr/Ped Actn:				4	Obj Strk: 20			
Unit	2 : 12	Alchl/Drgs:	7	Speed:	0 MPH	Dir:	E	Veh Mnvr/Ped Actn:				2	Obj Strk: 20			
870	103485462	42.140	06/26/2012 21:17	MOVABLE OBJECT	\$ 13000	0	0	0	0	1	2	1	1	4	10	1
Unit	1 : 4	Alchl/Drgs:	0	Speed:	65 MPH	Dir:	NW	Veh Mnvr/Ped Actn:				4	Obj Strk: 62			
871	103134867	42.240	04/13/2011 14:30	OTHER NON-COLLISION	\$ 500	0	0	0	0	1	1	1	1	0	0	
Unit	1 : 11	Alchl/Drgs:	0	Speed:	60 MPH	Dir:	W	Veh Mnvr/Ped Actn:				4	Obj Strk:			
Unit	2 : 14	Alchl/Drgs:	0	Speed:	60 MPH	Dir:	W	Veh Mnvr/Ped Actn:				4	Obj Strk:			
872	103311178	42.240	11/24/2011 10:28	FIXED OBJECT	\$ 6300	0	0	0	0	1	1	1	1	0	0	
Unit	1 : 1	Alchl/Drgs:	0	Speed:	60 MPH	Dir:	SE	Veh Mnvr/Ped Actn:				4	Obj Strk: 44			
873	103496707	42.240	07/13/2012 11:10	SIDESWIPE, SAME DIRECTION	\$ 5000	0	0	0	0	2	1	3	1	0	0	
Unit	1 : 2	Alchl/Drgs:	0	Speed:	60 MPH	Dir:	W	Veh Mnvr/Ped Actn:				5	Obj Strk:			
Unit	2 : 2	Alchl/Drgs:	0	Speed:	60 MPH	Dir:	W	Veh Mnvr/Ped Actn:				4	Obj Strk:			
874	103232141	42.286	08/19/2011 07:01	SIDESWIPE, SAME DIRECTION	\$ 1300	0	0	0	0	1	1	1	5	0	0	
Unit	1 : 14	Alchl/Drgs:	0	Speed:	60 MPH	Dir:	E	Veh Mnvr/Ped Actn:				4	Obj Strk:			
Unit	2 : 1	Alchl/Drgs:	0	Speed:	60 MPH	Dir:	E	Veh Mnvr/Ped Actn:				5	Obj Strk:			
875	102797502	42.367	02/21/2010 07:00	FIXED OBJECT	\$ 5800	0	0	2	0	1	5	1	5	0	0	
Unit	1 : 1	Alchl/Drgs:	1	Speed:	65 MPH	Dir:	W	Veh Mnvr/Ped Actn:				4	Obj Strk: 42			
876	103287588	42.373	10/28/2011 09:26	FIXED OBJECT	\$ 38000	0	0	0	0	2	1	3	1	0	0	
Unit	1 : 14	Alchl/Drgs:	0	Speed:	45 MPH	Dir:	W	Veh Mnvr/Ped Actn:				4	Obj Strk: 44			

**North Carolina Department of Transportation
Traffic Engineering Accident Analysis System
Strip Analysis Report**

Acc No	Crash ID	Milepost	Date	Accident Type	Total Damage	Injuries				Condition			Road		Trfc Ctl	
						F	A	B	C	R	L	W	Ch	Ci	Dv	Op
877	103202027	42.397	07/16/2011 14:21	REAR END, SLOW OR STOP	\$ 6600	1	0	3	1	1	1	2	1	0	0	
Unit	1 : 1	Alchl/Drgs:	0	Speed: 65 MPH Dir: W		Veh Mnvr/Ped Actn:				1	Obj Strk:					
Unit	2 : 20	Alchl/Drgs:	0	Speed: 65 MPH Dir: W		Veh Mnvr/Ped Actn:				4	Obj Strk:					
Unit	3 : 20	Alchl/Drgs:	0	Speed: 65 MPH Dir: W		Veh Mnvr/Ped Actn:				4	Obj Strk:					
Unit	4 : 20	Alchl/Drgs:	0	Speed: 65 MPH Dir: W		Veh Mnvr/Ped Actn:				4	Obj Strk:					
Unit	5 : 20	Alchl/Drgs:	0	Speed: 65 MPH Dir: W		Veh Mnvr/Ped Actn:				4	Obj Strk:					
878	103184223	42.476	06/20/2011 18:15	SIDESWIPE, SAME DIRECTION	\$ 2500	0	0	0	0	1	1	1	1	0	0	
Unit	1 : 1	Alchl/Drgs:	0	Speed: 65 MPH Dir: W		Veh Mnvr/Ped Actn:				4	Obj Strk:					
Unit	2 : 2	Alchl/Drgs:	0	Speed: 60 MPH Dir: W		Veh Mnvr/Ped Actn:				4	Obj Strk:					
879	103205217	42.540	07/16/2011 14:32	REAR END, SLOW OR STOP	\$ 2000	0	0	0	0	1	1	2	1	0	0	
Unit	1 : 1	Alchl/Drgs:	0	Speed: 40 MPH Dir: W		Veh Mnvr/Ped Actn:				4	Obj Strk:					
Unit	2 : 5	Alchl/Drgs:	0	Speed: 30 MPH Dir: W		Veh Mnvr/Ped Actn:				4	Obj Strk:					
880	103263132	42.540	09/27/2011 20:45	FIXED OBJECT	\$ 1800	0	0	0	0	1	5	1	1	0	0	
Unit	1 : 1	Alchl/Drgs:	7	Speed: 60 MPH Dir: W		Veh Mnvr/Ped Actn:				4	Obj Strk: 64					
881	102824778	42.640	03/27/2010 08:40	REAR END, SLOW OR STOP	\$ 3600	0	0	0	1	1	1	1	1	0	0	
Unit	1 : 2	Alchl/Drgs:	0	Speed: 60 MPH Dir: W		Veh Mnvr/Ped Actn:				4	Obj Strk:					
Unit	2 : 1	Alchl/Drgs:	0	Speed: 60 MPH Dir: W		Veh Mnvr/Ped Actn:				11	Obj Strk:					
882	102816806	42.740	03/17/2010 15:27	MOVABLE OBJECT	\$ 500	0	0	0	0	1	1	2	1	0	0	
Unit	1 : 1	Alchl/Drgs:	0	Speed: 60 MPH Dir: W		Veh Mnvr/Ped Actn:				4	Obj Strk: 18					
Unit	2 : 2	Alchl/Drgs:	0	Speed: 60 MPH Dir: W		Veh Mnvr/Ped Actn:				4	Obj Strk: 18					
883	103151458	42.740	05/08/2011 04:48	FIXED OBJECT	\$ 3800	0	0	1	1	1	5	1	7	0	0	
Unit	1 : 1	Alchl/Drgs:	1	Speed: 70 MPH Dir: NW		Veh Mnvr/Ped Actn:				4	Obj Strk: 44					
884	102912921	42.783	07/14/2010 12:18	SIDESWIPE, SAME DIRECTION	\$ 30900	0	0	0	0	1	1	1	3	0	0	
Unit	1 : 2	Alchl/Drgs:	0	Speed: 65 MPH Dir: SE		Veh Mnvr/Ped Actn:				5	Obj Strk: 44					
Unit	2 : 1	Alchl/Drgs:	0	Speed: 65 MPH Dir: SE		Veh Mnvr/Ped Actn:				4	Obj Strk:					
885	102754734	42.802	11/25/2009 19:54	SIDESWIPE, SAME DIRECTION	\$ 4000	0	0	0	0	1	1	1	1	0	0	
Unit	1 : 1	Alchl/Drgs:	0	Speed: 60 MPH Dir: W		Veh Mnvr/Ped Actn:				5	Obj Strk:					
Unit	2 : 5	Alchl/Drgs:	0	Speed: 65 MPH Dir: W		Veh Mnvr/Ped Actn:				4	Obj Strk:					

**North Carolina Department of Transportation
Traffic Engineering Accident Analysis System
Strip Analysis Report**

Acc No	Crash ID	Milepost	Date	Accident Type	Total Damage	Injuries				Condition			Road		Trfc Ctl	
						F	A	B	C	R	L	W	Ch	Ci	Dv	Op
886	102741575	42.940	11/21/2009 03:20	OVERTURN/ROLLOVER	\$ 2000	0	0	1	0	1	5	1	5	0	0	
Unit	1 : 2	Alchl/Drugs:	0	Speed:	60 MPH Dir: NW	Veh Mnvr/Ped Actn:				4	Obj Strk:					
887	102751080	42.940	12/02/2009 16:10	FIXED OBJECT	\$ 3000	0	0	0	0	2	1	3	1	0	0	
Unit	1 : 5	Alchl/Drugs:	0	Speed:	60 MPH Dir: E	Veh Mnvr/Ped Actn:				4	Obj Strk:		44			
888	102938146	42.940	08/14/2010 17:15	FIXED OBJECT	\$ 100	0	0	0	0	1	1	1	7	0	0	
Unit	1 : 1	Alchl/Drugs:	3	Speed:	40 MPH Dir: E	Veh Mnvr/Ped Actn:				4	Obj Strk:		44			
889	103423626	42.940	04/09/2012 08:40	FIXED OBJECT	\$ 1700	0	0	0	0	1	1	1	1	0	0	
Unit	1 : 5	Alchl/Drugs:	0	Speed:	60 MPH Dir: E	Veh Mnvr/Ped Actn:				4	Obj Strk:		44			
890	103458822	42.940	05/12/2012 22:51	OTHER NON-COLLISION	\$ 2400	0	0	0	2	1	5	1	7	2	0	
Unit	1 : 4	Alchl/Drugs:	0	Speed:	50 MPH Dir: E	Veh Mnvr/Ped Actn:				4	Obj Strk:					
Unit	2 : 1	Alchl/Drugs:	0	Speed:	55 MPH Dir: E	Veh Mnvr/Ped Actn:				4	Obj Strk:		18			
891	102677339	43.240	09/21/2009 19:25	FIXED OBJECT	\$ 8000	0	0	0	0	2	5	2	5	0	0	
Unit	1 : 4	Alchl/Drugs:	0	Speed:	55 MPH Dir: W	Veh Mnvr/Ped Actn:				4	Obj Strk:		59			
892	102766977	43.240	01/14/2010 07:10	SIDESWIPE, SAME DIRECTION	\$ 1150	0	0	0	0	1	5	1	7	0	0	
Unit	1 : 1	Alchl/Drugs:	0	Speed:	65 MPH Dir: E	Veh Mnvr/Ped Actn:				4	Obj Strk:					
Unit	2 : 2	Alchl/Drugs:	0	Speed:	55 MPH Dir: E	Veh Mnvr/Ped Actn:				4	Obj Strk:					
893	103367276	43.240	02/01/2012 14:03	SIDESWIPE, SAME DIRECTION	\$ 2400	0	0	0	0	2	1	2	1	0	0	
Unit	1 : 2	Alchl/Drugs:	0	Speed:	50 MPH Dir: E	Veh Mnvr/Ped Actn:				5	Obj Strk:					
Unit	2 : 1	Alchl/Drugs:	0	Speed:	60 MPH Dir: E	Veh Mnvr/Ped Actn:				4	Obj Strk:					
894	102667757	43.340	09/04/2009 17:20	REAR END, SLOW OR STOP	\$ 5250	0	0	0	1	1	1	1	1	0	0	
Unit	1 : 1	Alchl/Drugs:	0	Speed:	60 MPH Dir: E	Veh Mnvr/Ped Actn:				5	Obj Strk:					
Unit	2 : 1	Alchl/Drugs:	0	Speed:	60 MPH Dir: E	Veh Mnvr/Ped Actn:				4	Obj Strk:					
Unit	3 : 1	Alchl/Drugs:	0	Speed:	60 MPH Dir: E	Veh Mnvr/Ped Actn:				4	Obj Strk:					
895	102685431	43.340	09/26/2009 11:48	FIXED OBJECT	\$ 8000	0	0	0	1	2	1	2	7	0	0	
Unit	1 : 1	Alchl/Drugs:	0	Speed:	55 MPH Dir: E	Veh Mnvr/Ped Actn:				4	Obj Strk:		48			
896	103375555	43.340	02/12/2012 18:00	FIXED OBJECT	\$ 2500	0	0	0	1	1	1	1	1	0	0	
Unit	1 : 1	Alchl/Drugs:	0	Speed:	60 MPH Dir: W	Veh Mnvr/Ped Actn:				5	Obj Strk:		42			

**North Carolina Department of Transportation
Traffic Engineering Accident Analysis System
Strip Analysis Report**

Acc No	Crash ID	Milepost	Date	Accident Type	Total Damage	Injuries				Condition			Road		Trfc Ctl	
						F	A	B	C	R	L	W	Ch	Ci	Dv	Op
897	103050056	43.386	12/20/2010 06:55	SIDESWIPE, SAME DIRECTION	\$ 4480	0	0	0	0	1	1	1	1	0	0	
Unit	1 : 1	Alchl/Drgs:	0	Speed: 55 MPH Dir: E		Veh Mnvr/Ped Actn:				4	Obj Strk:					
Unit	2 : 1	Alchl/Drgs:	0	Speed: 55 MPH Dir: E		Veh Mnvr/Ped Actn:				5	Obj Strk:					
898	102656572	43.440	08/17/2009 08:25	FIXED OBJECT	\$ 4000	0	0	0	0	1	1	5	7	0	0	
Unit	1 : 1	Alchl/Drgs:	0	Speed: 55 MPH Dir: E		Veh Mnvr/Ped Actn:				4	Obj Strk:		48			
899	103283476	43.540	10/24/2011 00:26	FIXED OBJECT	\$ 18300	0	0	0	0	1	1	1	7	0	0	
Unit	1 : 4	Alchl/Drgs:	0	Speed: 55 MPH Dir: S		Veh Mnvr/Ped Actn:				4	Obj Strk:		42			
900	103312477	43.540	11/26/2011 15:36	OVERTURN/ROLLOVER	\$ 4000	1	0	0	0	1	1	2	3	0	0	
Unit	1 : 20	Alchl/Drgs:	0	Speed: 60 MPH Dir: NW		Veh Mnvr/Ped Actn:				4	Obj Strk:		44			
901	102900780	43.640	06/29/2010 13:52	FIXED OBJECT	\$ 4500	0	0	0	1	2	1	3	1	0	0	
Unit	1 : 2	Alchl/Drgs:	0	Speed: 55 MPH Dir: N		Veh Mnvr/Ped Actn:				4	Obj Strk:		48			
902	102948114	43.640	08/26/2010 16:30	FIXED OBJECT	\$ 2000	0	0	0	0	2	1	2	5	0	0	
Unit	1 : 1	Alchl/Drgs:	0	Speed: 60 MPH Dir: E		Veh Mnvr/Ped Actn:				4	Obj Strk:		42			
903	103169377	43.640	06/02/2011 16:11	REAR END, SLOW OR STOP	\$ 3500	0	0	0	0	2	1	2	1	0	0	
Unit	1 : 1	Alchl/Drgs:	0	Speed: 55 MPH Dir: E		Veh Mnvr/Ped Actn:				4	Obj Strk:					
Unit	2 : 1	Alchl/Drgs:	0	Speed: 55 MPH Dir: E		Veh Mnvr/Ped Actn:				11	Obj Strk:					
904	103238704	43.710	08/30/2011 11:02	REAR END, SLOW OR STOP	\$ 5000	0	0	0	0	1	1	1	3	0	0	
Unit	1 : 14	Alchl/Drgs:	0	Speed: 35 MPH Dir: W		Veh Mnvr/Ped Actn:				4	Obj Strk:					
Unit	2 : 1	Alchl/Drgs:	0	Speed: 60 MPH Dir: W		Veh Mnvr/Ped Actn:				4	Obj Strk:					
905	102903198	43.740	07/01/2010 17:46	OTHER COLLISION WITH VEHICLE	\$ 2000	0	0	0	2	1	1	1	3	0	0	
Unit	1 : 2	Alchl/Drgs:	0	Speed: 65 MPH Dir: E		Veh Mnvr/Ped Actn:				4	Obj Strk:					
Unit	2 : 2	Alchl/Drgs:	0	Speed: 70 MPH Dir: E		Veh Mnvr/Ped Actn:				5	Obj Strk:					
906	103087782	43.740	01/26/2011 17:17	MOVABLE OBJECT	\$ 3000	0	0	0	0	1	2	2	1	0	0	
Unit	1 : 4	Alchl/Drgs:	0	Speed: 65 MPH Dir: E		Veh Mnvr/Ped Actn:				5	Obj Strk:		18			
907	103447667	43.740	05/11/2012 08:59	FIXED OBJECT	\$ 5800	0	0	1	0	1	1	1	7	0	0	
Unit	1 : 1	Alchl/Drgs:	0	Speed: 55 MPH Dir: SE		Veh Mnvr/Ped Actn:				4	Obj Strk:		44			

**North Carolina Department of Transportation
Traffic Engineering Accident Analysis System
Strip Analysis Report**

Acc No	Crash ID	Milepost	Date	Accident Type	Total Damage	Injuries				Condition			Road		Trfc Ctl	
						F	A	B	C	R	L	W	Ch	Ci	Dv	Op
908	102659227	43.840	08/23/2009 17:18	FIXED OBJECT	\$ 8000	0	0	0	0	2	1	2	1	0	0	
Unit	1 : 1	Alchl/Drgs:	0	Speed: 65 MPH	Dir: E	Veh Mnvr/Ped Actn:				4	Obj Strk:		44			
909	102699243	43.840	10/20/2009 08:51	REAR END, SLOW OR STOP	\$ 5000	0	0	0	0	1	1	1	3	0	0	
Unit	1 : 14	Alchl/Drgs:	0	Speed: 35 MPH	Dir: W	Veh Mnvr/Ped Actn:				4	Obj Strk:					
Unit	2 : 14	Alchl/Drgs:	0	Speed: 25 MPH	Dir: W	Veh Mnvr/Ped Actn:				11	Obj Strk:					
910	102843904	43.840	04/19/2010 20:08	FIXED OBJECT	\$ 7500	0	0	0	0	1	5	1	7	0	0	
Unit	1 : 1	Alchl/Drgs:	1	Speed: 60 MPH	Dir: S	Veh Mnvr/Ped Actn:				4	Obj Strk:		48			
911	103097194	43.840	02/23/2011 07:59	ANIMAL	\$ 2500	0	0	0	0	1	1	1	1	0	0	
Unit	1 : 1	Alchl/Drgs:	0	Speed: 0 MPH	Dir: N	Veh Mnvr/Ped Actn:				4	Obj Strk:		17			
912	103224433	43.840	08/10/2011 06:17	SIDESWIPE, SAME DIRECTION	\$ 2700	0	0	0	0	1	1	1	1	0	0	
Unit	1 : 4	Alchl/Drgs:	0	Speed: 65 MPH	Dir: E	Veh Mnvr/Ped Actn:				4	Obj Strk:					
Unit	2 : 2	Alchl/Drgs:	0	Speed: 60 MPH	Dir: E	Veh Mnvr/Ped Actn:				4	Obj Strk:					
913	103015987	43.960	11/16/2010 18:00	ANIMAL	\$ 8500	0	0	0	0	1	5	1		0		
Unit	1 : 1	Alchl/Drgs:	0	Speed: 55 MPH	Dir: N	Veh Mnvr/Ped Actn:				4	Obj Strk:		17			
914	103319642	43.986	11/27/2011 15:00	REAR END, SLOW OR STOP	\$ 4500	0	0	0	2	1	1	2	3	0	0	
Unit	1 : 1	Alchl/Drgs:	0	Speed: 55 MPH	Dir: N	Veh Mnvr/Ped Actn:				4	Obj Strk:					
Unit	2 : 4	Alchl/Drgs:	0	Speed: 55 MPH	Dir: N	Veh Mnvr/Ped Actn:				4	Obj Strk:					
915	103348073	43.986	01/02/2012 22:28	FIXED OBJECT	\$ 5000	0	0	0	0	5	5	4	7	0	0	
Unit	1 : 1	Alchl/Drgs:	0	Speed: 45 MPH	Dir: W	Veh Mnvr/Ped Actn:				4	Obj Strk:		48			
916	102917186	44.140	07/21/2010 00:57	RAN OFF ROAD - RIGHT	\$ 17500	0	0	0	0	1	5	1	7	0	0	
Unit	1 : 12	Alchl/Drgs:	0	Speed: 70 MPH	Dir: W	Veh Mnvr/Ped Actn:				4	Obj Strk:					
917	103041018	44.140	12/14/2010 09:49	MOVABLE OBJECT	\$ 1500	0	0	0	0	1	1	1	7	0	0	
Unit	1 : 2	Alchl/Drgs:	0	Speed: 55 MPH	Dir: W	Veh Mnvr/Ped Actn:				4	Obj Strk:					
Unit	2 : 5	Alchl/Drgs:	0	Speed: 55 MPH	Dir: W	Veh Mnvr/Ped Actn:				4	Obj Strk:		18			
918	103043345	44.140	12/14/2010 22:47	FIXED OBJECT	\$ 8000	0	0	0	1	1	5	2	1	0	0	
Unit	1 : 1	Alchl/Drgs:	0	Speed: 65 MPH	Dir: E	Veh Mnvr/Ped Actn:				4	Obj Strk:		44			

**North Carolina Department of Transportation
Traffic Engineering Accident Analysis System
Strip Analysis Report**

Acc No	Crash ID	Milepost	Date	Accident Type	Total Damage	Injuries				Condition			Road		Trfc Ctl	
						F	A	B	C	R	L	W	Ch	Ci	Dv	Op
919	103069687	44.193	01/18/2011 20:32	REAR END, SLOW OR STOP	\$ 800	0	0	0	0	2	5	5	3	0	0	
Unit	1 : 1	Alchl/Drgs:	0	Speed: 65 MPH Dir: E		Veh Mnvr/Ped Actn:				4	Obj Strk:					
Unit	2 : 32	Alchl/Drgs:	7	Speed: 70 MPH Dir: E		Veh Mnvr/Ped Actn:				4	Obj Strk:					
920	102897667	44.260	06/25/2010 15:39	FIXED OBJECT	\$ 7750	0	0	0	0	2	1	3	7	0	0	
Unit	1 : 1	Alchl/Drgs:	0	Speed: 45 MPH Dir: W		Veh Mnvr/Ped Actn:				4	Obj Strk:		44			
921	103200907	44.286	07/14/2011 12:59	SIDESWIPE, SAME DIRECTION	\$ 4100	0	0	0	0	1	1	1	3	0	0	
Unit	1 : 1	Alchl/Drgs:	0	Speed: 45 MPH Dir: N		Veh Mnvr/Ped Actn:				1	Obj Strk:					
Unit	2 : 5	Alchl/Drgs:	0	Speed: 60 MPH Dir: N		Veh Mnvr/Ped Actn:				4	Obj Strk:		42			
922	102971038	44.305	09/27/2010 10:42	REAR END, SLOW OR STOP	\$ 5500	0	0	0	2	2	1	3	7	0	0	
Unit	1 : 4	Alchl/Drgs:	0	Speed: 55 MPH Dir: W		Veh Mnvr/Ped Actn:				1	Obj Strk:					
Unit	2 : 1	Alchl/Drgs:	0	Speed: 50 MPH Dir: W		Veh Mnvr/Ped Actn:				1	Obj Strk:					
Unit	3 : 2	Alchl/Drgs:	0	Speed: 55 MPH Dir: W		Veh Mnvr/Ped Actn:				4	Obj Strk:					
923	102720317	44.340	11/11/2009 19:08	FIXED OBJECT	\$ 1200	0	0	0	0	2	5	2	7	0	0	
Unit	1 : 1	Alchl/Drgs:	0	Speed: 55 MPH Dir: SE		Veh Mnvr/Ped Actn:				4	Obj Strk:		46			
924	102770275	44.340	12/14/2009 09:45	FIXED OBJECT	\$ 4500	0	0	0	0	1	1	1	7	0		
Unit	1 : 1	Alchl/Drgs:	0	Speed: 55 MPH Dir: E		Veh Mnvr/Ped Actn:				4	Obj Strk:		46			
925	102845940	44.340	04/22/2010 17:00	FIXED OBJECT	\$ 9300	0	0	0	0	1	1	1	1	0	0	
Unit	1 : 1	Alchl/Drgs:	0	Speed: 60 MPH Dir: S		Veh Mnvr/Ped Actn:				4	Obj Strk:		44			
926	103121267	44.340	03/26/2011 16:52	RAN OFF ROAD - LEFT	\$ 2000	0	0	0	0	2	1	3	7	0	0	
Unit	1 : 4	Alchl/Drgs:	0	Speed: 55 MPH Dir: E		Veh Mnvr/Ped Actn:				4	Obj Strk:		48			
927	103448860	44.440	05/13/2012 00:01	OTHER COLLISION WITH VEHICLE	\$ 1000	0	0	0	0	1	5	1	7	2	0	
Unit	1 : 4	Alchl/Drgs:	0	Speed: 50 MPH Dir: E		Veh Mnvr/Ped Actn:				4	Obj Strk:					
Unit	2 : 1	Alchl/Drgs:	0	Speed: 55 MPH Dir: E		Veh Mnvr/Ped Actn:				4	Obj Strk:		18			
928	102831156	44.536	03/26/2010 15:57	REAR END, SLOW OR STOP	\$ 7300	0	0	0	0	1	1	1	1	0	0	
Unit	1 : 4	Alchl/Drgs:	0	Speed: 55 MPH Dir: SE		Veh Mnvr/Ped Actn:				4	Obj Strk:					
Unit	2 : 1	Alchl/Drgs:	0	Speed: 55 MPH Dir: SE		Veh Mnvr/Ped Actn:				11	Obj Strk:					
Unit	3 : 4	Alchl/Drgs:	0	Speed: 55 MPH Dir: SE		Veh Mnvr/Ped Actn:				11	Obj Strk:					

**North Carolina Department of Transportation
Traffic Engineering Accident Analysis System
Strip Analysis Report**

Acc No	Crash ID	Milepost	Date	Accident Type	Total Damage	Injuries				Condition			Road		Trfc Ctl	
						F	A	B	C	R	L	W	Ch	Ci	Dv	Op
929	102824683	44.536	03/26/2010 16:00	REAR END, SLOW OR STOP	\$ 3400	0	0	0	0	1	1	1	1	0	0	
Unit	1 : 1	Alchl/Drgs:	0	Speed: 55 MPH Dir: E		Veh Mnvr/Ped Actn:				4	Obj Strk:					
Unit	2 : 1	Alchl/Drgs:	0	Speed: 55 MPH Dir: E		Veh Mnvr/Ped Actn:				11	Obj Strk:					
930	102925920	44.536	07/31/2010 16:21	FIXED OBJECT	\$ 22000	0	0	0	0	2	1	2	1	0	0	
Unit	1 : 2	Alchl/Drgs:	0	Speed: 55 MPH Dir: E		Veh Mnvr/Ped Actn:				5	Obj Strk:		50			
931	103316889	44.536	11/30/2011 03:53	FIXED OBJECT	\$ 950	0	0	0	0	4	5	2	5	0	0	
Unit	1 : 1	Alchl/Drgs:	0	Speed: 50 MPH Dir: E		Veh Mnvr/Ped Actn:				4	Obj Strk:		50			
932	103403631	44.536	03/16/2012 16:15	REAR END, SLOW OR STOP	\$ 21800	0	0	1	1	2	1	2	1	0	0	
Unit	1 : 2	Alchl/Drgs:	0	Speed: 55 MPH Dir: W		Veh Mnvr/Ped Actn:				11	Obj Strk:					
Unit	2 : 4	Alchl/Drgs:	0	Speed: 55 MPH Dir: W		Veh Mnvr/Ped Actn:				11	Obj Strk:					
Unit	3 : 1	Alchl/Drgs:	0	Speed: 55 MPH Dir: W		Veh Mnvr/Ped Actn:				11	Obj Strk:					
Unit	4 : 5	Alchl/Drgs:	0	Speed: 55 MPH Dir: W		Veh Mnvr/Ped Actn:				11	Obj Strk:					
933	103418396	44.536	04/03/2012 21:56	FIXED OBJECT	\$ 74000	0	0	1	0	2	5	1	7	0	0	
Unit	1 : 14	Alchl/Drgs:	0	Speed: 65 MPH Dir: E		Veh Mnvr/Ped Actn:				4	Obj Strk:		48			
934	103444281	44.536	05/07/2012 12:15	SIDESWIPE, SAME DIRECTION	\$ 4300	0	0	0	1	1	1	1	1	0	0	
Unit	1 : 14	Alchl/Drgs:	0	Speed: 55 MPH Dir: S		Veh Mnvr/Ped Actn:				5	Obj Strk:					
Unit	2 : 4	Alchl/Drgs:	0	Speed: 55 MPH Dir: S		Veh Mnvr/Ped Actn:				6	Obj Strk:		50			
935	103448766	44.536	05/12/2012 23:50	MOVABLE OBJECT	\$ 1000	0	0	0	0	1	6	1	3	2	0	
Unit	1 : 2	Alchl/Drgs:	0	Speed: 50 MPH Dir: E		Veh Mnvr/Ped Actn:				4	Obj Strk:					
Unit	2 : 20	Alchl/Drgs:	0	Speed: 55 MPH Dir: SE		Veh Mnvr/Ped Actn:				4	Obj Strk:		18			
936	102935181	44.586	08/10/2010 14:10	OVERTURN/ROLLOVER	\$ 6500	0	0	1	1	1	1	2	1	0	0	
Unit	1 : 4	Alchl/Drgs:	0	Speed: 65 MPH Dir: E		Veh Mnvr/Ped Actn:				4	Obj Strk:					
937	103344006	44.640	01/02/2012 23:27	PARKED MOTOR VEHICLE	\$ 6500	0	0	0	0	5	5	4	3	0	0	
Unit	1 : 12	Alchl/Drgs:	0	Speed: 40 MPH Dir: N		Veh Mnvr/Ped Actn:				4	Obj Strk:					
Unit	2 : 10	Alchl/Drgs:	7	Speed: 0 MPH Dir: N		Veh Mnvr/Ped Actn:				3	Obj Strk:		20			
Unit	3 : 1	Alchl/Drgs:	0	Speed: 40 MPH Dir: N		Veh Mnvr/Ped Actn:				4	Obj Strk:		20			
938	102881848	44.740	06/07/2010 12:20	FIXED OBJECT	\$ 12500	0	0	0	0	1	1	1	7	0	0	
Unit	1 : 12	Alchl/Drgs:	0	Speed: 20 MPH Dir: N		Veh Mnvr/Ped Actn:				4	Obj Strk:		41			

**North Carolina Department of Transportation
Traffic Engineering Accident Analysis System
Strip Analysis Report**

Acc No	Crash ID	Milepost	Date	Accident Type	Total Damage	Injuries				Condition			Road		Trfc Ctl	
						F	A	B	C	R	L	W	Ch	Ci	Dv	Op
939	103294545	44.740	11/06/2011 16:16	REAR END, SLOW OR STOP	\$ 4500	0	0	0	0	1	1	1	3	0	0	
Unit	1 : 1	Alchl/Drgs:	0	Speed: 55 MPH Dir: SE		Veh Mnvr/Ped Actn:				4	Obj Strk:					
Unit	2 : 2	Alchl/Drgs:	0	Speed: 55 MPH Dir: SE		Veh Mnvr/Ped Actn:				4	Obj Strk:					
940	102871143	44.760	05/21/2010 15:24	OTHER COLLISION WITH VEHICLE	\$ 900	0	0	0	0	2	1	2	3	0	0	
Unit	1 : 14	Alchl/Drgs:	0	Speed: 55 MPH Dir: E		Veh Mnvr/Ped Actn:				4	Obj Strk:					
Unit	2 : 1	Alchl/Drgs:	0	Speed: 55 MPH Dir: E		Veh Mnvr/Ped Actn:				4	Obj Strk:					
941	102666303	44.786	08/16/2009 18:15	OVERTURN/ROLLOVER	\$ 23000	0	0	0	1	1	1	2	1	0	0	
Unit	1 : 1	Alchl/Drgs:	0	Speed: 65 MPH Dir: W		Veh Mnvr/Ped Actn:				4	Obj Strk:		44			
942	102684412	44.790	09/15/2009 13:15	REAR END, SLOW OR STOP	\$ 3500	0	0	0	0	1	1	1	3	0	0	
Unit	1 : 32	Alchl/Drgs:	7	Speed: 55 MPH Dir: W		Veh Mnvr/Ped Actn:				11	Obj Strk:					
Unit	2 : 1	Alchl/Drgs:	0	Speed: 55 MPH Dir: W		Veh Mnvr/Ped Actn:				11	Obj Strk:					
943	102930226	44.840	08/05/2010 11:20	LEFT TURN, SAME ROADWAY	\$ 8500	0	0	0	0	1	1	1	1	0	0	
Unit	1 : 11	Alchl/Drgs:	0	Speed: 35 MPH Dir: E		Veh Mnvr/Ped Actn:				8	Obj Strk:					
Unit	2 : 1	Alchl/Drgs:	0	Speed: 55 MPH Dir: E		Veh Mnvr/Ped Actn:				4	Obj Strk:					
944	102869293	44.860	05/21/2010 13:18	RAN OFF ROAD - LEFT	\$ 2000	0	0	0	0	2	1	3	7	0	0	
Unit	1 : 1	Alchl/Drgs:	0	Speed: 60 MPH Dir: E		Veh Mnvr/Ped Actn:				4	Obj Strk:		48			
945	103428092	44.860	04/17/2012 00:52	FIXED OBJECT	\$ 1800	0	0	0	0	1	5	1	3	0	0	
Unit	1 : 1	Alchl/Drgs:	7	Speed: 20 MPH Dir: SE		Veh Mnvr/Ped Actn:				4	Obj Strk:		44			
946	102776658	44.886	01/26/2010 13:59	MOVABLE OBJECT	\$ 6000	0	0	0	0	1	1	1	7	0	10	1
Unit	1 : 2	Alchl/Drgs:	0	Speed: 55 MPH Dir: S		Veh Mnvr/Ped Actn:				4	Obj Strk:		18			
947	102958645	44.940	09/10/2010 11:45	SIDESWIPE, SAME DIRECTION	\$ 5700	0	0	0	0	1	1	1	1	0	0	
Unit	1 : 14	Alchl/Drgs:	0	Speed: 50 MPH Dir: E		Veh Mnvr/Ped Actn:				5	Obj Strk:					
Unit	2 : 1	Alchl/Drgs:	0	Speed: 55 MPH Dir: E		Veh Mnvr/Ped Actn:				4	Obj Strk:					
948	103002520	44.940	11/03/2010 07:11	RAN OFF ROAD - LEFT	\$ 12500	0	0	0	0	1	3	1	7	0	0	
Unit	1 : 10	Alchl/Drgs:	0	Speed: 50 MPH Dir: E		Veh Mnvr/Ped Actn:				4	Obj Strk:		18			

**North Carolina Department of Transportation
Traffic Engineering Accident Analysis System
Strip Analysis Report**

Acc No	Crash ID	Milepost	Date	Accident Type	Total Damage	Injuries				Condition			Road		Trfc Ctl	
						F	A	B	C	R	L	W	Ch	Ci	Dv	Op
949	103497221	44.940	07/15/2012 12:12	FIXED OBJECT	\$ 4000	0	0	0	0	2	1	3	7	0	0	
Unit	1 : 1	Alchl/Drugs:	0	Speed: 60 MPH	Dir: W	Veh Mnvr/Ped Actn:				4	Obj Strk:		44			
950	103135072	44.960	04/13/2011 23:56	ANIMAL	\$ 1500	0	0	0	0	1	5	1	2	0	0	
Unit	1 : 4	Alchl/Drugs:	0	Speed: 55 MPH	Dir: W	Veh Mnvr/Ped Actn:				4	Obj Strk:		17			
951	102834635	45.040	04/06/2010 15:51	SIDESWIPE, SAME DIRECTION	\$ 6600	0	0	0	1	1	1	1	5	0	0	
Unit	1 : 12	Alchl/Drugs:	0	Speed: 50 MPH	Dir: W	Veh Mnvr/Ped Actn:				4	Obj Strk:					
Unit	2 : 1	Alchl/Drugs:	0	Speed: 70 MPH	Dir: W	Veh Mnvr/Ped Actn:				4	Obj Strk:		50			
952	102752190	45.090	12/23/2009 10:45	SIDESWIPE, SAME DIRECTION	\$ 525	0	0	0	0	2	1	1	1	0	0	
Unit	1 : 5	Alchl/Drugs:	0	Speed: 65 MPH	Dir: E	Veh Mnvr/Ped Actn:				4	Obj Strk:					
Unit	2 : 1	Alchl/Drugs:	0	Speed: 65 MPH	Dir: SE	Veh Mnvr/Ped Actn:				4	Obj Strk:					
953	103476995	45.140	06/17/2012 22:48	REAR END, SLOW OR STOP	\$ 4000	0	0	0	0	1	5	1	1	0	0	
Unit	1 : 1	Alchl/Drugs:	0	Speed: 0 MPH	Dir: W	Veh Mnvr/Ped Actn:				5	Obj Strk:					
Unit	2 : 1	Alchl/Drugs:	0	Speed: 0 MPH	Dir: W	Veh Mnvr/Ped Actn:				1	Obj Strk:					
954	103348027	45.186	01/02/2012 20:26	FIXED OBJECT	\$ 5000	0	0	0	0	5	5	4	5	0	0	
Unit	1 : 2	Alchl/Drugs:	0	Speed: 55 MPH	Dir: E	Veh Mnvr/Ped Actn:				4	Obj Strk:		44			
955	103348489	45.186	01/02/2012 21:49	REAR END, SLOW OR STOP	\$ 3000	0	0	0	0	5	5	4	5	0	0	
Unit	1 : 4	Alchl/Drugs:	0	Speed: 35 MPH	Dir: W	Veh Mnvr/Ped Actn:				4	Obj Strk:					
Unit	2 : 2	Alchl/Drugs:	0	Speed: 45 MPH	Dir: W	Veh Mnvr/Ped Actn:				11	Obj Strk:					
956	103384423	45.186	02/22/2012 18:50	FIXED OBJECT	\$ 1000	0	0	0	0	1	5	1	1	0	0	
Unit	1 : 1	Alchl/Drugs:	0	Speed: 50 MPH	Dir: W	Veh Mnvr/Ped Actn:				4	Obj Strk:		44			
957	102768355	45.240	01/15/2010 12:00	REAR END, SLOW OR STOP	\$ 15250	0	1	0	0	1	1	1	3	0	0	
Unit	1 : 12	Alchl/Drugs:	0	Speed: 25 MPH	Dir: E	Veh Mnvr/Ped Actn:				4	Obj Strk:					
Unit	2 : 5	Alchl/Drugs:	0	Speed: 55 MPH	Dir: E	Veh Mnvr/Ped Actn:				4	Obj Strk:					
958	102912982	45.286	07/12/2010 21:22	ANIMAL	\$ 1000	0	0	0	0	1	5	1	1	0	0	
Unit	1 : 1	Alchl/Drugs:	0	Speed: 65 MPH	Dir: W	Veh Mnvr/Ped Actn:				4	Obj Strk:		17			
959	103179580	45.340	06/16/2011 13:28	REAR END, SLOW OR STOP	\$ 5300	0	0	0	0	1	1	1	1	0	0	
Unit	1 : 2	Alchl/Drugs:	0	Speed: 65 MPH	Dir: W	Veh Mnvr/Ped Actn:				4	Obj Strk:					

**North Carolina Department of Transportation
Traffic Engineering Accident Analysis System
Strip Analysis Report**

Acc No	Crash ID	Milepost	Date	Accident Type	Total Damage	Injuries				Condition			Road		Trfc Ctl	
						F	A	B	C	R	L	W	Ch	Ci	Dv	Op
Unit	2 : 4	Alchl/Drugs:	0	Speed:	65 MPH	Dir:	W	Veh Mnvr/Ped Actn:				11	Obj Strk:			
960	102766986	45.360	01/10/2010 12:05	FIXED OBJECT	\$ 850	0	0	0	0	1	1	1	7	0	0	
Unit	1 : 1	Alchl/Drugs:	0	Speed:	55 MPH	Dir:	NW	Veh Mnvr/Ped Actn:				4	Obj Strk:			
961	103165263	45.386	05/26/2011 15:45	FIXED OBJECT	\$ 5000	0	0	0	0	1	1	1	5	0	0	
Unit	1 : 2	Alchl/Drugs:	0	Speed:	60 MPH	Dir:	W	Veh Mnvr/Ped Actn:				4	Obj Strk:			
962	103312042	45.386	11/21/2011 15:57	OVERTURN/ROLLOVER	\$ 16300	0	0	1	0	2	1	2	5	0	0	
Unit	1 : 4	Alchl/Drugs:	2	Speed:	70 MPH	Dir:	E	Veh Mnvr/Ped Actn:				4	Obj Strk:			
963	102752950	45.460	12/26/2009 06:45	FIXED OBJECT	\$ 3500	0	0	0	0	4	5	1	5	0	0	
Unit	1 : 2	Alchl/Drugs:	0	Speed:	55 MPH	Dir:	W	Veh Mnvr/Ped Actn:				4	Obj Strk:			
964	103236077	45.460	08/19/2011 23:37	REAR END, SLOW OR STOP	\$ 5500	0	0	0	0	1	5	1	1	0	0	
Unit	1 : 2	Alchl/Drugs:	0	Speed:	65 MPH	Dir:	W	Veh Mnvr/Ped Actn:				11	Obj Strk:			
Unit	2 : 1	Alchl/Drugs:	0	Speed:	65 MPH	Dir:	W	Veh Mnvr/Ped Actn:				4	Obj Strk:			
965	103383408	45.460	02/20/2012 03:29	JACKKNIFE	\$ 12600	0	0	0	0	4	5	2	7	0	0	
Unit	1 : 2	Alchl/Drugs:	0	Speed:	65 MPH	Dir:	NW	Veh Mnvr/Ped Actn:				4	Obj Strk:			
966	103510268	45.460	07/31/2012 10:50	RAN OFF ROAD - RIGHT	\$ 36000	0	0	1	0	2	1	3	3	0	0	
Unit	1 : 14	Alchl/Drugs:	0	Speed:	55 MPH	Dir:	E	Veh Mnvr/Ped Actn:				4	Obj Strk:			
967	102752646	45.540	12/26/2009 06:12	RAN OFF ROAD - LEFT	\$ 13500	0	0	0	0	4	5	1	1	1	0	
Unit	1 : 4	Alchl/Drugs:	0	Speed:	60 MPH	Dir:	E	Veh Mnvr/Ped Actn:				4	Obj Strk:			
968	102675477	45.686	08/30/2009 11:30	OVERTURN/ROLLOVER	\$ 3500	0	1	0	0	1	1	1	1	0	0	
Unit	1 : 1	Alchl/Drugs:	3	Speed:	60 MPH	Dir:	W	Veh Mnvr/Ped Actn:				4	Obj Strk:			
969	103239931	45.730	08/31/2011 14:31	FIXED OBJECT	\$ 2500	0	0	1	0	1	1	1	3	0	0	
Unit	1 : 1	Alchl/Drugs:	0	Speed:	60 MPH	Dir:	NW	Veh Mnvr/Ped Actn:				4	Obj Strk:			
Unit	2 : 1	Alchl/Drugs:	0	Speed:	65 MPH	Dir:	NW	Veh Mnvr/Ped Actn:				4	Obj Strk:			
970	102878491	45.840	06/02/2010 16:37	MOVABLE OBJECT	\$ 800	0	0	1	0	2	1	3	1	0	0	
Unit	1 : 14	Alchl/Drugs:	0	Speed:	60 MPH	Dir:	W	Veh Mnvr/Ped Actn:				4	Obj Strk:			
Unit	2 : 1	Alchl/Drugs:	0	Speed:	60 MPH	Dir:	W	Veh Mnvr/Ped Actn:				4	Obj Strk:			

**North Carolina Department of Transportation
Traffic Engineering Accident Analysis System
Strip Analysis Report**

Acc No	Crash ID	Milepost	Date	Accident Type	Total Damage	Injuries				Condition			Road		Trfc Ctl	
						F	A	B	C	R	L	W	Ch	Ci	Dv	Op
971	103374810	45.840	02/10/2012 22:24	FIXED OBJECT	\$ 3000	0	0	2	0	1	5	2	7	2	0	
Unit	1 : 1	Alchl/Drgs:	0	Speed:	65 MPH	Dir:	W	Veh Mnvr/Ped Actn:				15	Obj Strk:		33	
972	102937502	45.960	08/11/2010 14:30	SIDESWIPE, SAME DIRECTION	\$ 3000	0	0	0	0	1	1	1	1	0	0	
Unit	1 : 4	Alchl/Drgs:	0	Speed:	65 MPH	Dir:	E	Veh Mnvr/Ped Actn:				5	Obj Strk:			
Unit	2 : 1	Alchl/Drgs:	0	Speed:	65 MPH	Dir:	E	Veh Mnvr/Ped Actn:				4	Obj Strk:			
973	103185862	45.986	06/24/2011 14:21	ANIMAL	\$ 2000	0	0	0	0	1	1	1	3	0	0	
Unit	1 : 1	Alchl/Drgs:	0	Speed:	65 MPH	Dir:	N	Veh Mnvr/Ped Actn:				4	Obj Strk:		17	
974	103192690	46.060	07/03/2011 07:10	FIXED OBJECT	\$ 6000	0	0	0	1	1	3	1	1	0	0	
Unit	1 : 1	Alchl/Drgs:	0	Speed:	65 MPH	Dir:	W	Veh Mnvr/Ped Actn:				4	Obj Strk:		44	
975	103500600	46.090	07/15/2012 12:15	FIXED OBJECT	\$ 1950	0	0	0	0	1	1	1	3	0	0	
Unit	1 : 2	Alchl/Drgs:	0	Speed:	60 MPH	Dir:	E	Veh Mnvr/Ped Actn:				5	Obj Strk:			
Unit	2 : 1	Alchl/Drgs:	0	Speed:	65 MPH	Dir:	E	Veh Mnvr/Ped Actn:				4	Obj Strk:		42	
976	103265593	46.140	10/03/2011 15:26	FIXED OBJECT	\$ 3800	0	0	0	0	10	1	1	3	0	0	
Unit	1 : 2	Alchl/Drgs:	0	Speed:	60 MPH	Dir:	W	Veh Mnvr/Ped Actn:				8	Obj Strk:		43	
977	102918535	46.190	07/21/2010 12:32	MOVABLE OBJECT	\$ 250	0	0	0	0	1	1	1	3	0	0	
Unit	1 : 2	Alchl/Drgs:	0	Speed:	65 MPH	Dir:	W	Veh Mnvr/Ped Actn:				6	Obj Strk:		18	
978	102927106	46.290	07/31/2010 18:02	ANIMAL	\$ 1200	0	0	0	0	2	1	2	5	0	0	
Unit	1 : 1	Alchl/Drgs:	0	Speed:	65 MPH	Dir:	W	Veh Mnvr/Ped Actn:				4	Obj Strk:		17	
979	102747178	46.340	12/17/2009 23:49	REAR END, SLOW OR STOP	\$ 900	0	0	0	0	1	5	2	1	0	0	
Unit	1 : 4	Alchl/Drgs:	1	Speed:	70 MPH	Dir:	S	Veh Mnvr/Ped Actn:				4	Obj Strk:			
Unit	2 : 1	Alchl/Drgs:	0	Speed:	65 MPH	Dir:	S	Veh Mnvr/Ped Actn:				4	Obj Strk:			
980	103272096	46.340	10/10/2011 10:12	FIXED OBJECT	\$ 1500	0	0	0	0	1	1	2	1	0	0	
Unit	1 : 1	Alchl/Drgs:	0	Speed:	65 MPH	Dir:	E	Veh Mnvr/Ped Actn:				4	Obj Strk:		44	
981	103369874	46.340	02/04/2012 13:53	FIXED OBJECT	\$ 8800	0	0	1	0	2	1	2	5	0	0	
Unit	1 : 2	Alchl/Drgs:	0	Speed:	75 MPH	Dir:	NW	Veh Mnvr/Ped Actn:				4	Obj Strk:		44	

**North Carolina Department of Transportation
Traffic Engineering Accident Analysis System
Strip Analysis Report**

Acc No	Crash ID	Milepost	Date	Accident Type	Total Damage	Injuries				Condition			Road		Trfc Ctl	
						F	A	B	C	R	L	W	Ch	Ci	Dv	Op
982	103205241	46.540	07/15/2011 14:07	FIXED OBJECT	\$ 4000	0	0	0	0	2	1	2	3	0	0	
Unit	1 : 1	Alchl/Drgs:	0	Speed:	60 MPH Dir: E	Veh Mnvr/Ped Actn:				4	Obj Strk:		44			
Unit	2 : 5	Alchl/Drgs:	0	Speed:	55 MPH Dir: E	Veh Mnvr/Ped Actn:				4	Obj Strk:					
983	103299957	46.590	11/10/2011 18:00	ANIMAL	\$ 3500	0	0	0	0	1	5	1	3	0	0	
Unit	1 : 1	Alchl/Drgs:	0	Speed:	60 MPH Dir: NW	Veh Mnvr/Ped Actn:				4	Obj Strk:		17			
984	103179553	46.690	06/16/2011 11:37	ANIMAL	\$ 5000	0	0	0	0	1	1	1	1	0	0	
Unit	1 : 1	Alchl/Drgs:	0	Speed:	65 MPH Dir: E	Veh Mnvr/Ped Actn:				4	Obj Strk:		17			
985	103053363	46.840	12/27/2010 22:22	FIXED OBJECT	\$ 10000	0	0	0	1	2	5	1	1	0	0	
Unit	1 : 1	Alchl/Drgs:	0	Speed:	55 MPH Dir: E	Veh Mnvr/Ped Actn:				4	Obj Strk:		48			
986	103369751	47.000	02/02/2012 00:06	FIXED OBJECT	\$ 4000	0	0	0	0	2	5	3	1	0	0	
Unit	1 : 1	Alchl/Drgs:	0	Speed:	75 MPH Dir: N	Veh Mnvr/Ped Actn:				4	Obj Strk:		42			
987	103373442	47.810	02/08/2012 08:26	FIXED OBJECT	\$ 3000	0	0	0	0	1	1	1	3	0	0	
Unit	1 : 1	Alchl/Drgs:	0	Speed:	65 MPH Dir: W	Veh Mnvr/Ped Actn:				4	Obj Strk:		42			
988	102837471	48.140	04/11/2010 01:30	ANIMAL	\$ 9000	0	0	0	0	1	1	1	1	0	0	
Unit	1 : 1	Alchl/Drgs:	0	Speed:	60 MPH Dir: W	Veh Mnvr/Ped Actn:				4	Obj Strk:		17			
989	103506426	48.195	07/26/2012 13:16	MOVABLE OBJECT	\$ 1000	0	0	0	0	1	1	1	1	0	0	
Unit	1 : 1	Alchl/Drgs:	0	Speed:	60 MPH Dir: W	Veh Mnvr/Ped Actn:				4	Obj Strk:		18			
990	102710289	48.200	10/19/2009 16:55	OVERTURN/ROLLOVER	\$ 7800	0	0	0	0	1	1	1	3	0		
Unit	1 : 4	Alchl/Drgs:	0	Speed:	65 MPH Dir: W	Veh Mnvr/Ped Actn:				4	Obj Strk:		41			
991	103025008	48.200	11/27/2010 15:30	ANIMAL	\$ 1500	0	0	0	0	1	1	1	3	0	0	
Unit	1 : 1	Alchl/Drgs:	0	Speed:	60 MPH Dir: W	Veh Mnvr/Ped Actn:				4	Obj Strk:		17			
992	103185952	48.495	06/26/2011 12:58	FIXED OBJECT	\$ 1500	0	0	0	0	1	1	1	1	0	0	
Unit	1 : 1	Alchl/Drgs:	0	Speed:	65 MPH Dir: W	Veh Mnvr/Ped Actn:				4	Obj Strk:		44			
993	102837472	48.540	04/11/2010 02:00	REAR END, SLOW OR STOP	\$ 11200	0	0	0	0	1	1	1	1	0	0	
Unit	1 : 12	Alchl/Drgs:	0	Speed:	60 MPH Dir: W	Veh Mnvr/Ped Actn:				4	Obj Strk:					

**North Carolina Department of Transportation
Traffic Engineering Accident Analysis System
Strip Analysis Report**

Acc No	Crash ID	Milepost	Date	Accident Type	Total Damage	Injuries				Condition			Road		Trfc Ctl	
						F	A	B	C	R	L	W	Ch	Ci	Dv	Op
Unit	2 : 4	Alchl/Drgs:	0	Speed:	65 MPH Dir: W	Veh Mnvr/Ped Actn:				4	Obj Strk:					
994	103404414	48.595	03/16/2012 17:28	REAR END, SLOW OR STOP	\$ 7000	0	0	0	0	2	1	2	5	0	0	
Unit	1 : 1	Alchl/Drgs:	0	Speed:	50 MPH Dir: W	Veh Mnvr/Ped Actn:				4	Obj Strk:					
Unit	2 : 2	Alchl/Drgs:	0	Speed:	50 MPH Dir: W	Veh Mnvr/Ped Actn:				1	Obj Strk:					
995	103417606	48.670	03/29/2012 09:03	ANIMAL	\$ 1500	0	0	0	0	1	1	1	1	0	0	
Unit	1 : 1	Alchl/Drgs:	0	Speed:	65 MPH Dir: W	Veh Mnvr/Ped Actn:				4	Obj Strk: 17					
996	103420103	48.700	04/08/2012 09:02	ANIMAL	\$ 1000	0	0	0	0	1	1	1	1	0	0	
Unit	1 : 5	Alchl/Drgs:	0	Speed:	60 MPH Dir: E	Veh Mnvr/Ped Actn:				4	Obj Strk: 17					
997	102800545	48.723	02/05/2010 09:00	FIXED OBJECT	\$ 8150	0	0	0	2	4	1	6	1	0	0	
Unit	1 : 1	Alchl/Drgs:	0	Speed:	65 MPH Dir: E	Veh Mnvr/Ped Actn:				4	Obj Strk: 64					
998	102888231	48.795	06/15/2010 13:05	REAR END, SLOW OR STOP	\$ 1000	0	0	0	0	1	1	1	3	0	0	
Unit	1 : 10	Alchl/Drgs:	0	Speed:	0 MPH Dir: W	Veh Mnvr/Ped Actn:				4	Obj Strk:					
Unit	2 : 1	Alchl/Drgs:	0	Speed:	0 MPH Dir: W	Veh Mnvr/Ped Actn:				1	Obj Strk:					
999	103037631	48.810	12/10/2010 08:40	FIXED OBJECT	\$ 5000	0	0	1	1	1	1	1	1	0	0	
Unit	1 : 1	Alchl/Drgs:	0	Speed:	65 MPH Dir: W	Veh Mnvr/Ped Actn:				4	Obj Strk: 59					
1000	102784469	49.010	02/02/2010 11:15	FIXED OBJECT	\$ 800	0	0	0	0	2	1	3	5	0	0	
Unit	1 : 1	Alchl/Drgs:	0	Speed:	65 MPH Dir: W	Veh Mnvr/Ped Actn:				4	Obj Strk: 44					
1001	102952655	49.200	08/29/2010 13:18	SIDESWIPE, SAME DIRECTION	\$ 9000	0	0	0	0	1	1	1	1	0	0	
Unit	1 : 4	Alchl/Drgs:	0	Speed:	55 MPH Dir: W	Veh Mnvr/Ped Actn:				5	Obj Strk:					
Unit	2 : 1	Alchl/Drgs:	0	Speed:	65 MPH Dir: W	Veh Mnvr/Ped Actn:				4	Obj Strk:					
1002	102752870	49.210	12/26/2009 05:06	RAN OFF ROAD - RIGHT	\$ 2000	0	0	0	0	4	5	1	1	1	0	
Unit	1 : 1	Alchl/Drgs:	0	Speed:	60 MPH Dir: W	Veh Mnvr/Ped Actn:				4	Obj Strk: 33					
1003	102877653	49.210	05/31/2010 22:00	FIXED OBJECT	\$ 8000	0	0	1	0	1	5	2	1	0	0	
Unit	1 : 1	Alchl/Drgs:	1	Speed:	75 MPH Dir: W	Veh Mnvr/Ped Actn:				4	Obj Strk: 59					
1004	103093999	49.210	02/20/2011 07:52	FIXED OBJECT	\$ 10000	1	0	0	0	1	1	1	7	0	0	
Unit	1 : 2	Alchl/Drgs:	6	Speed:	95 MPH Dir: W	Veh Mnvr/Ped Actn:				4	Obj Strk: 42					

**North Carolina Department of Transportation
Traffic Engineering Accident Analysis System
Strip Analysis Report**

Acc No	Crash ID	Milepost	Date	Accident Type	Total Damage	Injuries				Condition			Road		Trfc Ctl	
						F	A	B	C	R	L	W	Ch	Ci	Dv	Op
1005	103318660	49.210	12/03/2011 01:05	OTHER COLLISION WITH VEHICLE	\$ 26000	0	0	0	0	1	5	1	1	0	0	
Unit	1 : 12	Alchl/Drugs:	0	Speed: 55 MPH	Dir: E	Veh Mnvr/Ped Actn:				4	Obj Strk:					
Unit	2 : 2	Alchl/Drugs:	0	Speed: 70 MPH	Dir: E	Veh Mnvr/Ped Actn:				4	Obj Strk:					
1006	103315737	49.310	11/30/2011 06:20	FIXED OBJECT	\$ 5000	0	0	0	0	4	5	1	1	0	0	
Unit	1 : 1	Alchl/Drugs:	0	Speed: 65 MPH	Dir: E	Veh Mnvr/Ped Actn:				4	Obj Strk: 59					

Legend for Report Details:

- Acc No - Accident Number
- Injuries: F - Fatal, A - Class A, B - Class B, C - Class C
- Condition: R - Road Surface, L - Ambient Light, W - Weather
- Rd Ch - Road Character
- Rd Ci - Roadway Contributing Circumstances
- Trfc Ctl - Traffic Control: Dv - Device, Op - Operating
- Alchl/Drugs - Alcohol Drugs Suspected
- Veh Mnvr/Ped Actn - Vehicle Maneuver/Pedestrian Action
- Obj Strk - Object Struck

**North Carolina Department of Transportation
Traffic Engineering Accident Analysis System
Strip Analysis Report**

Summary Statistics

High Level Crash Summary

Crash Type	Number of Crashes	Percent of Total
Total Crashes	1006	100.00
Fatal Crashes	9	0.89
Non-Fatal Injury Crashes	265	26.34
Total Injury Crashes	274	27.24
Property Damage Only Crashes	732	72.76
Night Crashes	248	24.65
Wet Crashes	201	19.98
Alcohol/Drugs Involvement Crashes	42	4.17

Crash Severity Summary

Crash Type	Number of Crashes	Percent of Total
Total Crashes	1006	100.00
Fatal Crashes	9	0.89
Class A Crashes	11	1.09
Class B Crashes	88	8.75
Class C Crashes	166	16.50
Property Damage Only Crashes	732	72.76

Vehicle Exposure Statistics

Annual ADT = 58000

Total Length = 30.36 (Miles) 48.86 (Kilometers)

Total Vehicle Exposure = 1929.92 (MVMT) 3105.91 (MVKMT)

Crash Rate	Crashes Per 100 Million Vehicle Miles	Crashes Per 100 Million Vehicle Kilometers
Total Crash Rate	52.13	32.39
Fatal Crash Rate	0.47	0.29
Non Fatal Crash Rate	13.73	8.53
Night Crash Rate	12.85	7.98
Wet Crash Rate	10.41	6.47
EPDO Rate	228.07	141.72

**North Carolina Department of Transportation
Traffic Engineering Accident Analysis System
Strip Analysis Report**

Miscellaneous Statistics

Severity Index = 4.38
 EPDO Crash Index = 4401.60
 Estimated Property Damage Total = \$ 5714351.00

Accident Type Summary

Accident Type	Number of Crashes	Percent of Total
ANGLE	6	0.60
ANIMAL	36	3.58
BACKING UP	1	0.10
FIXED OBJECT	203	20.18
JACKKNIFE	3	0.30
LEFT TURN, DIFFERENT ROADWAYS	1	0.10
LEFT TURN, SAME ROADWAY	1	0.10
MOVABLE OBJECT	68	6.76
OTHER COLLISION WITH VEHICLE	20	1.99
OTHER NON-COLLISION	15	1.49
OVERTURN/ROLLOVER	22	2.19
PARKED MOTOR VEHICLE	4	0.40
PEDESTRIAN	2	0.20
RAN OFF ROAD - LEFT	36	3.58
RAN OFF ROAD - RIGHT	34	3.38
REAR END, SLOW OR STOP	386	38.37
REAR END, TURN	1	0.10
RIGHT TURN, DIFFERENT ROADWAYS	1	0.10
SIDESWIPE, SAME DIRECTION	166	16.50

Injury Summary

Injury Type	Number of Injuries	Percent of Total
Fatal Injuries	13	3.10
Class A Injuries	16	3.81
Class B Injuries	122	29.05
Class C Injuries	269	64.05
Total Non-Fatal Injuries	407	96.90
Total Injuries	420	100.00

North Carolina Department of Transportation
Traffic Engineering Accident Analysis System
Strip Analysis Report

Monthly Summary

Month	Number of Crashes	Percent of Total
Jan	68	6.76
Feb	54	5.37
Mar	66	6.56
Apr	78	7.75
May	65	6.46
Jun	117	11.63
Jul	120	11.93
Aug	88	8.75
Sep	73	7.26
Oct	125	12.43
Nov	73	7.26
Dec	79	7.85

Daily Summary

Day	Number of Crashes	Percent of Total
Mon	124	12.33
Tue	124	12.33
Wed	125	12.43
Thu	133	13.22
Fri	204	20.28
Sat	160	15.90
Sun	136	13.52

**North Carolina Department of Transportation
Traffic Engineering Accident Analysis System
Strip Analysis Report**

Hourly Summary

Hour	Number of Crashes	Percent of Total
0000-0059	17	1.69
0100-0159	12	1.19
0200-0259	13	1.29
0300-0359	11	1.09
0400-0459	9	0.89
0500-0559	11	1.09
0600-0659	32	3.18
0700-0759	37	3.68
0800-0859	42	4.17
0900-0959	38	3.78
1000-1059	37	3.68
1100-1159	61	6.06
1200-1259	58	5.77
1300-1359	62	6.16
1400-1459	89	8.85
1500-1559	93	9.24
1600-1659	85	8.45
1700-1759	79	7.85
1800-1859	64	6.36
1900-1959	47	4.67
2000-2059	32	3.18
2100-2159	34	3.38
2200-2259	21	2.09
2300-2359	22	2.19

**North Carolina Department of Transportation
Traffic Engineering Accident Analysis System
Strip Analysis Report**

Light and Road Conditions Summary

Condition	Dry	Wet	Other	Total
Day	554	146	28	728
Dark	176	47	25	248
Other	21	8	1	30
Total	751	201	54	1006

Object Struck Summary

Object Type	Times Struck	Percent of Total
ANIMAL	36	7.36
BRIDGE RAIL END	1	0.20
BRIDGE RAIL FACE	5	1.02
CATCH BASIN OR CULVERT ON SHOULDER	2	0.41
CONSTRUCTION BARRIER	2	0.41
DITCH	2	0.41
EMBANKMENT	41	8.38
FENCE OR FENCE POST	1	0.20
GUARDRAIL END IN MEDIAN	1	0.20
GUARDRAIL END ON SHOULDER	7	1.43
GUARDRAIL FACE IN MEDIAN	137	28.02
GUARDRAIL FACE ON SHOULDER	92	18.81
MEDIAN BARRIER FACE	28	5.73
MOVABLE OBJECT	82	16.77
OFFICIAL HIGHWAY SIGN BREAKAWAY	5	1.02
OFFICIAL HIGHWAY SIGN NON-BREAKAWAY	3	0.61
OTHER FIXED OBJECT	7	1.43
PARKED MOTOR VEHICLE	11	2.25
PEDESTRIAN	8	1.64
SHOULDER BARRIER FACE	9	1.84
TREE	8	1.64
UTILITY POLE	1	0.20

Vehicle Type Summary

Vehicle Type	Number Involved	Percent of Total
ACTIVITY BUS	1	0.06
COMMERCIAL BUS	1	0.06
EMS VEHICLE, AMBULANCE, RESCUE SQUAD	1	0.06
LIGHT TRUCK (MINI-VAN, PANEL)	27	1.49

**North Carolina Department of Transportation
Traffic Engineering Accident Analysis System
Strip Analysis Report**

Vehicle Type	Number Involved	Percent of Total
MOTOR HOME/RECREATIONAL VEHICLE	4	0.22
MOTORCYCLE	23	1.27
OTHER BUS	1	0.06
PASSENGER CAR	848	46.82
PEDESTRIAN	3	0.17
PICKUP	284	15.68
POLICE	4	0.22
SINGLE UNIT TRUCK (2-AXLE, 6-TIRE)	33	1.82
SINGLE UNIT TRUCK (3 OR MORE AXLES)	12	0.66
SPORT UTILITY	330	18.22
TRACTOR/DOULBES	7	0.39
TRACTOR/SEMI-TRAILER	106	5.85
TRUCK/TRACTOR	1	0.06
TRUCK/TRAILER	22	1.21
UNKNOWN	16	0.88
VAN	87	4.80

North Carolina Department of Transportation
Traffic Engineering Accident Analysis System
Strip Analysis Report

Yearly Totals Summary

Accident Totals

Year	Total Accidents	Fatal Accidents	Injury Accidents	Property Damage Only Accidents
2009	140	1	42	97
2010	370	1	99	270
2011	292	6	78	208
2012	204	1	46	157
Total	1006	9	265	732

Injury Totals

Year	Fatal Injuries	Class A, B, or C Injuries
2009	1	64
2010	5	153
2011	6	126
2012	1	64
Total	13	407

Miscellaneous Totals

Year	Property Damage	EPDO Index
2009	\$ 743655	731.80
2010	\$ 2070904	1452.00
2011	\$ 1548872	1460.80
2012	\$ 1350920	757.00
Total	\$ 5714351	4401.60

Type of Accident Totals

Year	Left Turn	Right Turn	Rear End	Run Off Road &			
				Fixed Object	Angle	Side Swipe	Other
2009	1	0	56	33	0	21	29
2010	1	0	159	85	2	64	59
2011	0	1	100	91	2	50	48
2012	0	0	72	64	2	31	35
Total	2	1	387	273	6	166	171

**North Carolina Department of Transportation
Traffic Engineering Accident Analysis System
Strip Analysis Report**

Strip Diagram

Features	Milepost	Crash IDs
I 40 I 240 US 74 EXIT 31 STRUCTURE	18.95	
	18.96	103346360
	18.97	103032037
	18.98	
	18.99	102789500
	19.00	
	19.01	103502976 103162626
	19.02	
	19.03	
	19.04	
	19.05	102894961 103106332 103382120 103425156 103483107
	19.06	
	19.07	
	19.08	
	19.09	
	19.10	
	19.11	
	19.12	
	19.13	
	19.14	
	19.15	102683889 102705375 102698879 103316308
	19.16	
	19.17	
	19.18	
	19.19	103429664
	19.20	102800065 102988220
	19.21	
	19.22	
	19.23	
	19.24	
	19.25	103197337 103219739 103499265
	19.26	
	19.27	
	19.28	
	19.29	
	19.30	102708121
	19.31	
	19.32	
	19.33	
	19.34	
	19.35	

**North Carolina Department of Transportation
Traffic Engineering Accident Analysis System
Strip Analysis Report**

Features	Milepost	Crash IDs
	19.36	
	19.37	
	19.38	
	19.39	102950515
	19.40	102850417
	19.41	
MILE MARKER	19.42	103026612
	19.43	
	19.44	
	19.45	102863083 103035366 103302517 103324320 103324329 103388471
	19.46	103229786
	19.47	102711532
	19.48	103162663
	19.49	
	19.50	103406972
	19.51	102684237 102802570 102929299 102963837 103193167 103434652
	19.52	
	19.53	
	19.54	
	19.55	
	19.56	
	19.57	
	19.58	
	19.59	
	19.60	103509868
	19.61	
	19.62	102686217
	19.63	
	19.64	
	19.65	103114693 103233826 103254981
	19.66	
	19.67	
	19.68	
SR 3431 POND STRUCTURE	19.69	
	19.70	
	19.71	
	19.72	
	19.73	
	19.74	
	19.75	
	19.76	
	19.77	
	19.78	

**North Carolina Department of Transportation
Traffic Engineering Accident Analysis System
Strip Analysis Report**

Features	Milepost	Crash IDs
	19.79	
MILE MARKER	19.80	
	19.81	102984230
	19.82	
	19.83	
	19.84	
	19.85	
	19.86	
	19.87	
	19.88	
	19.89	
	19.90	
	19.91	
MILE MARKER	19.92	
	19.93	
	19.94	
	19.95	102959180 103153037 103396041 103396064 103396062 103412884 103455000
	19.96	
	19.97	
	19.98	
	19.99	
	20.00	
	20.01	102924612 102956037 103228625
	20.02	
	20.03	
	20.04	
	20.05	
	20.06	
	20.07	
	20.08	
	20.09	
	20.10	102992638
	20.11	
	20.12	102984238
	20.13	
	20.14	
	20.15	
	20.16	
	20.17	
	20.18	
	20.19	
	20.20	103245113
	20.21	102684228 102822984
	20.22	
	20.23	

**North Carolina Department of Transportation
Traffic Engineering Accident Analysis System
Strip Analysis Report**

Features	Milepost	Crash IDs
	20.24	
	20.25	102855182
	20.26	102950229 103230678
	20.27	
	20.28	
	20.29	
	20.30	103345638
	20.31	102796195 102835071 102850411 103213665 103418254
	20.32	103403644
	20.33	
	20.34	103316375
	20.35	
	20.36	
	20.37	
	20.38	
	20.39	
	20.40	
	20.41	102900239 103223969 103378055 103472140 103503359
MILE MARKER	20.42	103179347 103369147 103219755
	20.43	
	20.44	
	20.45	102843045 103058761
	20.46	
	20.47	
	20.48	103219754
	20.49	102799999 103021891 103164481 103215134
	20.50	
NC 191 BREVARD EXIT 33	20.51	102683643 102855859 103114696 103162668 103179036 103219752 103229336 103369153 103511035 103506986 103519490
	20.52	102840444 102962178 103145474
	20.53	102850445 102950781
	20.54	
	20.55	102683901 102968573 103187239
	20.56	
	20.57	102659772
	20.58	
	20.59	102947016
	20.60	
	20.61	102850850 102859690 102903247 103136443 103213642 103322297 103403814 103404264 103462749

**North Carolina Department of Transportation
Traffic Engineering Accident Analysis System
Strip Analysis Report**

Features	Milepost	Crash IDs
	20.62	103341576
	20.63	
	20.64	
	20.65	
	20.66	
	20.67	
	20.68	
	20.69	
	20.70	103498053
	20.71	102890670 103021876 103020511 103020504 103223967 103386029 103399046 103454816
	20.72	
	20.73	102950228 103353453
	20.74	
	20.75	
	20.76	102988223 102988219
	20.77	
	20.78	
	20.79	103411796
MILE MARKER	20.80	
	20.81	102780818 103279178 103425899
STRUCTURE	20.82	
	20.83	
	20.84	
	20.85	
	20.86	
	20.87	
	20.88	
	20.89	102652100
	20.90	
	20.91	102986666
MILE MARKER	20.92	102980990 103191629 103285554
	20.93	
	20.94	
	20.95	103414309
	20.96	
	20.97	
	20.98	
	20.99	
	21.00	
	21.01	102654673 102767999 103184369 103297198 103287966 103320344 103498045
	21.02	103247241 103299466 103385106 103508395
	21.03	
	21.04	

**North Carolina Department of Transportation
Traffic Engineering Accident Analysis System
Strip Analysis Report**

Features	Milepost	Crash IDs
	21.05	
	21.06	102802431
	21.07	
	21.08	
	21.09	
	21.10	
	21.11	
	21.12	
	21.13	
	21.14	102963834 103021331
	21.15	
	21.16	
	21.17	102988231
	21.18	
	21.19	
	21.20	
	21.21	
	21.22	103011412
	21.23	
	21.24	
	21.25	
	21.26	
	21.27	
	21.28	
	21.29	
MILE MARKER	21.30	
	21.31	103160118 103403966
	21.32	102883418 103280978 103511870
	21.33	
	21.34	
	21.35	
	21.36	
	21.37	
	21.38	
	21.39	103061708
	21.40	
	21.41	
MILE MARKER	21.42	102742270 102757661 102955839 102971476
	21.43	
	21.44	103299445 103459084
	21.45	
	21.46	
	21.47	
	21.48	103403633
	21.49	102914255

**North Carolina Department of Transportation
Traffic Engineering Accident Analysis System
Strip Analysis Report**

Features	Milepost	Crash IDs
	21.50	
	21.51	102651619 102855256 102897986 102925444 102949203 102961637 103317205 103417563
	21.52	102862354 103097490 103221163 103284420 103281334 103471375
	21.53	
	21.54	103197829
	21.55	
	21.56	103120130
	21.57	
	21.58	102907481
	21.59	
	21.60	102789352
	21.61	102658727 102674911
	21.62	102752573 102897729 102917753 103159528 103200811 103294093 103392407 103455669
	21.63	
	21.64	
	21.65	
	21.66	
	21.67	
	21.68	
SR 3482 FERRY	21.69	
	21.70	
	21.71	
	21.72	102988379
	21.73	
	21.74	
	21.75	
	21.76	
	21.77	
	21.78	
	21.79	
MILE MARKER	21.80	
	21.81	
	21.82	103166263
	21.83	
	21.84	
	21.85	
	21.86	
	21.87	
	21.88	103470805
	21.89	
	21.90	
	21.91	103487391

**North Carolina Department of Transportation
Traffic Engineering Accident Analysis System
Strip Analysis Report**

Features	Milepost	Crash IDs
MILE MARKER	21.92	102980991 103062262 103129586 103252721 103476236 103493568
	21.93	
	21.94	
	21.95	
	21.96	103235582
	21.97	
	21.98	
	21.99	
	22.00	
	22.01	102880028
	22.02	102778898 102984984 103196323 103485004
	22.03	
	22.04	103143869
	22.05	
	22.06	
	22.07	
	22.08	
	22.09	102680235
	22.10	
	22.11	
	22.12	103190354 103237059 103338917
	22.13	
	22.14	
	22.15	
	22.16	
	22.17	
	22.18	
	22.19	
	22.20	
	22.21	
	22.22	103391175
	22.23	
	22.24	
	22.25	
	22.26	
	22.27	
	22.28	
	22.29	
	22.30	
	22.31	
	22.32	102975723 102993756 103046146 103284422
	22.33	
	22.34	
	22.35	
	22.36	

**North Carolina Department of Transportation
Traffic Engineering Accident Analysis System
Strip Analysis Report**

Features	Milepost	Crash IDs
	22.37	
	22.38	
	22.39	103126456
	22.40	
	22.41	103387228
MILE MARKER	22.42	102661037 102993819 102997974 103181104 103234251 103282168
	22.43	
	22.44	
STRUCTURE	22.45	102887814 102951805 103134173 103294104
	22.46	
	22.47	
	22.48	
	22.49	
	22.50	
	22.51	102813104 102826428 102846937 102856611
	22.52	102966694 102992785 103043516 103279138
	22.53	
	22.54	
	22.55	103064102
	22.56	
	22.57	
	22.58	
	22.59	
	22.60	
	22.61	102911207 103292632 103404494
	22.62	102878472 102897508 103114761 103221151 103226851
	22.63	
	22.64	
	22.65	
	22.66	
	22.67	
	22.68	
	22.69	
	22.70	
	22.71	102906199
	22.72	102898085
	22.73	
	22.74	
	22.75	
	22.76	
	22.77	
	22.78	
	22.79	

**North Carolina Department of Transportation
Traffic Engineering Accident Analysis System
Strip Analysis Report**

Features	Milepost	Crash IDs
MILE MARKER	22.80	
	22.81	
	22.82	103068183 103187919 103464019 103485257
	22.83	
	22.84	
	22.85	
	22.86	
	22.87	
	22.88	
	22.89	
	22.90	
	22.91	
MILE MARKER	22.92	102762410 103222281 103236626 103272011 103489285
	22.93	
	22.94	
	22.95	
	22.96	
	22.97	103481753
	22.98	
	22.99	
	23.00	
	23.01	103156155 103404226
	23.02	
	23.03	
	23.04	102865865 102899193
	23.05	
	23.06	
	23.07	
	23.08	102659499
	23.09	
	23.10	
	23.11	103328104
	23.12	103139620
	23.13	
	23.14	102815969
	23.15	
	23.16	
	23.17	103496504
	23.18	
	23.19	
	23.20	
	23.21	102809406
	23.22	
	23.23	

**North Carolina Department of Transportation
Traffic Engineering Accident Analysis System
Strip Analysis Report**

Features	Milepost	Crash IDs
	23.24	102943216
	23.25	
	23.26	
	23.27	
	23.28	
	23.29	
	23.30	
	23.31	
	23.32	102960184 103051194 103428769
	23.33	
	23.34	102951806
	23.35	
	23.36	
	23.37	
	23.38	
	23.39	
	23.40	
	23.41	
MILE MARKER	23.42	102742228 102918976 102925940 102959761 103032991 102980989 103123359 103464546
	23.43	
	23.44	103200065
	23.45	
	23.46	
	23.47	
	23.48	
	23.49	
	23.50	
	23.51	103080273 103499847
	23.52	103151532
	23.53	
	23.54	
	23.55	
	23.56	
	23.57	
	23.58	
	23.59	
	23.60	
	23.61	
	23.62	103079446 103174666 103231790
	23.63	
	23.64	103156892
	23.65	
	23.66	
	23.67	102898297 103171195

**North Carolina Department of Transportation
Traffic Engineering Accident Analysis System
Strip Analysis Report**

Features	Milepost	Crash IDs
	23.68	
	23.69	
	23.70	
	23.71	
	23.72	
	23.73	
	23.74	
	23.75	
	23.76	
	23.77	
	23.78	
	23.79	
MILE MARKER	23.80	
	23.81	
	23.82	102683917 102851546 103299391
	23.83	
	23.84	
	23.85	
	23.86	
	23.87	
	23.88	102993345
	23.89	
	23.90	
	23.91	103000907
MILE MARKER	23.92	102740520 102792368 102851599 102951043 102961546 103031472 103046230 103180406 103190811 103384298 103407371
	23.93	
	23.94	103051278 103231953
	23.95	
	23.96	
	23.97	
	23.98	103182380
	23.99	
	24.00	
	24.01	
	24.02	102825431 102980598 103028436 103415204 103456417
	24.03	
	24.04	102986976
	24.05	103497085
	24.06	103203655
	24.07	
BLUE RIDGE	24.08	102758575
	24.09	

**North Carolina Department of Transportation
Traffic Engineering Accident Analysis System
Strip Analysis Report**

Features	Milepost	Crash IDs
	24.10	
	24.11	
	24.12	103170591 103310725
	24.13	
	24.14	102802559 102884421 103018878 103027650 103057232 103171617
	24.15	
	24.16	
	24.17	
	24.18	103309938
	24.19	
	24.20	
	24.21	
	24.22	102773486 102980594 103107924 103486600
	24.23	
	24.24	
	24.25	102768315
	24.26	103497278
	24.27	
	24.28	
	24.29	
	24.30	103508468
	24.31	
	24.32	102710172 102739886 102887830 103030944 103073837 103176293 103351140 103379527 103416736
	24.33	
	24.34	102908715
	24.35	103065862
	24.36	
	24.37	
	24.38	
	24.39	102768314
	24.40	102774315
	24.41	102752424 103414360
MILE MARKER	24.42	103033003 103398312
	24.43	103243506
	24.44	
	24.45	
	24.46	
	24.47	
	24.48	
	24.49	
	24.50	
	24.51	

**North Carolina Department of Transportation
Traffic Engineering Accident Analysis System
Strip Analysis Report**

Features	Milepost	Crash IDs
	24.52	102869533 102908605 102953660 102974290 102973460 103157756 103168557 103179144 103304263
STRUCTURE	24.53	102653206
	24.54	102697099
	24.55	
	24.56	
	24.57	
	24.58	102701040
	24.59	
	24.60	
	24.61	
	24.62	102691180 102908662
	24.63	
	24.64	102757656 102897627 102898145 103024448 103146479
	24.65	
	24.66	
	24.67	
	24.68	
	24.69	
	24.70	
	24.71	102940880
	24.72	102738830
	24.73	
	24.74	102728312 103123358 103200073
	24.75	
	24.76	
	24.77	
	24.78	
	24.79	102789991 102789994
MILE MARKER	24.80	102657279
	24.81	102784138
	24.82	103444671
	24.83	
	24.84	102765301 102827298 102901421 102903627 102932028 103104153 103287472
	24.85	
	24.86	
	24.87	
	24.88	
	24.89	102943464 103481712
	24.90	
	24.91	
MILE MARKER	24.92	102920025 103096674 103191175 103269005

**North Carolina Department of Transportation
Traffic Engineering Accident Analysis System
Strip Analysis Report**

Features	Milepost	Crash IDs
		103342915
	24.93	
	24.94	102707661 102767704 102848679 102886109
		103051147 103051218 103236610
	24.95	
	24.96	
	24.97	
	24.98	
	24.99	
	25.00	102770478
	25.01	103192456
	25.02	
	25.03	
	25.04	102677384 102707344 102750934 102751978
		102768613 102768630 102780641 102841745
		103196287 103244821 103281305 103353856
	25.05	
	25.06	
	25.07	
	25.08	
	25.09	
	25.10	
	25.11	
	25.12	
	25.13	
NC 146 LONG SHOALS STRUCTURE	25.14	102767709 103509947
	25.15	102779644
	25.16	103005632
	25.17	
	25.18	
	25.19	
	25.20	
	25.21	
	25.22	103148984
	25.23	
	25.24	102702477 102733523 102756359 102796203
		102834887 102993560 103279210 103336680
		103482374
	25.25	
	25.26	
	25.27	102897214
	25.28	103374978
	25.29	
	25.30	
	25.31	

**North Carolina Department of Transportation
Traffic Engineering Accident Analysis System
Strip Analysis Report**

Features	Milepost	Crash IDs
	25.32	103270003 103419924
	25.33	
	25.34	102779616 102838437 102864193 102891859 102920213 102920256 103436818 103471580
	25.35	
	25.36	
	25.37	
	25.38	
	25.39	102753761
	25.40	103191324
	25.41	
MILE MARKER	25.42	
	25.43	
	25.44	102679595 103011601 103336685
	25.45	
	25.46	
	25.47	102751747
	25.48	
	25.49	
	25.50	
	25.51	
	25.52	102914299 103095745 103288122
	25.53	
	25.54	
	25.55	
	25.56	103208440
	25.57	
	25.58	
	25.59	
	25.60	
	25.61	
	25.62	103190801
	25.63	
	25.64	102751751 102751856 102875197 103479415 103479425 103479435
	25.65	
	25.66	
	25.67	
	25.68	
	25.69	
	25.70	
	25.71	
	25.72	
	25.73	
	25.74	102773600

**North Carolina Department of Transportation
Traffic Engineering Accident Analysis System
Strip Analysis Report**

Features	Milepost	Crash IDs
	25.75	
STRUCTURE	25.76	
	25.77	
	25.78	
	25.79	
MILE MARKER	25.80	
	25.81	
	25.82	
	25.83	
	25.84	102901155
	25.85	
	25.86	
	25.87	103496496
	25.88	
	25.89	
	25.90	
	25.91	
MILE MARKER	25.92	102852621 103507715
	25.93	
	25.94	103370062
	25.95	
	25.96	
	25.97	
	25.98	
	25.99	
	26.00	
	26.01	
	26.02	
	26.03	
	26.04	
	26.05	
	26.06	
	26.07	
	26.08	
	26.09	
	26.10	102676042
	26.11	
	26.12	102917767 102961196
	26.13	
	26.14	102902166 102929244 102991639 103000588 103275600
	26.15	
	26.16	
	26.17	
	26.18	
	26.19	

**North Carolina Department of Transportation
Traffic Engineering Accident Analysis System
Strip Analysis Report**

Features	Milepost	Crash IDs
	26.20	
	26.21	
	26.22	102993149 103236853 103284684
	26.23	
	26.24	
	26.25	
	26.26	102809194 102852842 102999724 103501965
	26.27	102748635
	26.28	
	26.29	
	26.30	
	26.31	
	26.32	
	26.33	
	26.34	
	26.35	
	26.36	
	26.37	
	26.38	
	26.39	
	26.40	
	26.41	
MILE MARKER	26.42	102952802 103486743
	26.43	
	26.44	
	26.45	102994771
	26.46	
	26.47	
	26.48	
	26.49	
	26.50	
	26.51	
	26.52	103406570 103410339
	26.53	
	26.54	
	26.55	
	26.56	
	26.57	
	26.58	
	26.59	
	26.60	
	26.61	
	26.62	102732537 102851549 103419784
	26.63	
	26.64	
	26.65	

**North Carolina Department of Transportation
Traffic Engineering Accident Analysis System
Strip Analysis Report**

Features	Milepost	Crash IDs
	26.66	102645182
	26.67	102738888 103489396
	26.68	
	26.69	
	26.70	
	26.71	
	26.72	
	26.73	
	26.74	
	26.75	
	26.76	103001279
	26.77	
	26.78	
	26.79	
MILE MARKER	26.80	
	26.81	
	26.82	103213393
	26.83	
	26.84	
	26.85	
	26.86	
	26.87	
	26.88	
	26.89	
	26.90	
	26.91	
MILE MARKER	26.92	102751883
	26.93	
	26.94	
	26.95	
	26.96	
	26.97	
	26.98	
	26.99	
	27.00	
	27.01	
	27.02	102680429 102986559 102991490 103024027 103185788
	27.03	
	27.04	
SR 3495 GLENN BRIDGE STRUCTURE	27.05	103254546
	27.06	
	27.07	
	27.08	
	27.09	
	27.10	

**North Carolina Department of Transportation
Traffic Engineering Accident Analysis System
Strip Analysis Report**

Features	Milepost	Crash IDs
	27.11	
	27.12	103256261
	27.13	
	27.14	103189004
	27.15	
	27.16	
	27.17	
	27.18	
	27.19	
	27.20	
	27.21	
	27.22	102706306 102964464 103291052
	27.23	
	27.24	103208163
	27.25	
	27.26	102696600 102756952 103008576 103019583 103088682 103481671
	27.27	
	27.28	102879897
	27.29	
	27.30	
	27.31	
	27.32	102964528 103191238 103247642 103255321 103419777 103496731
	27.33	
	27.34	
	27.35	
	27.36	
	27.37	
	27.38	
	27.39	
	27.40	102700919
	27.41	
MILE MARKER	27.42	
	27.43	
	27.44	
	27.45	
	27.46	102986582 103112407
	27.47	
	27.48	
	27.49	
	27.50	
	27.51	
	27.52	103254282 103496491
	27.53	

**North Carolina Department of Transportation
Traffic Engineering Accident Analysis System
Strip Analysis Report**

Features	Milepost	Crash IDs
	27.54	
	27.55	103279862
	27.56	102724420 103294669
	27.57	
	27.58	
	27.59	
	27.60	
	27.61	
	27.62	103207541
	27.63	
	27.64	
	27.65	102747225
	27.66	102897719
	27.67	
	27.68	
	27.69	
	27.70	
	27.71	
	27.72	
	27.73	
	27.74	
	27.75	
	27.76	102936321 102964051 103175916
	27.77	
	27.78	
	27.79	
MILE MARKER	27.80	
	27.81	
	27.82	
	27.83	
	27.84	
	27.85	
	27.86	102766983 102986986 102991605 103151709 103204650
	27.87	
	27.88	
	27.89	
	27.90	
	27.91	
MILE MARKER	27.92	
	27.93	
	27.94	
	27.95	
	27.96	103011491 103019464 103191545
	27.97	

**North Carolina Department of Transportation
Traffic Engineering Accident Analysis System
Strip Analysis Report**

Features	Milepost	Crash IDs
	27.98	
	27.99	
	28.00	
	28.01	
	28.02	
	28.03	
	28.04	
	28.05	
	28.06	102709693 102930377 103011474 103195068 103275860 103495560
	28.07	
	28.08	
	28.09	
	28.10	
	28.11	
	28.12	
	28.13	
	28.14	
	28.15	
	28.16	102722432 102741040 102898196 102980919 103061891 103101188 103175907 103275706
	28.17	
	28.18	
	28.19	
	28.20	
	28.21	
	28.22	
	28.23	
	28.24	
CL-HENDERSON	28.25	
NC 280 AIRPORT	28.26	
	28.27	103025967
	28.28	
	28.29	
	28.30	
	28.31	
	28.32	102980930
	28.33	
	28.34	
	28.35	
	28.36	102693397 102980998 103214068 103488137
	28.37	
	28.38	
	28.39	
	28.40	
	28.41	

**North Carolina Department of Transportation
Traffic Engineering Accident Analysis System
Strip Analysis Report**

Features	Milepost	Crash IDs	
MILE MARKER	28.42		
	28.43		
	28.44		
	28.45		
	28.46		
	28.47		
	28.48		
	28.49		
	28.50		
	28.51		
	28.52		
	28.53		
	28.54		
	28.55		
	28.56		
	28.57		
	CL-HENDERSON	28.58	
		28.59	103488211
		28.60	
		28.61	
28.62			
28.63			
28.64			
28.65			
28.66			
28.67			
28.68			
28.69			
28.70			
28.71			
28.72			
28.73			
28.74			
28.75			
28.76			
28.77			
28.78			
28.79			
MILE MARKER	28.80		
	28.81		
	28.82		
	28.83		
	28.84		
	28.85		
	28.86		
	28.87		

**North Carolina Department of Transportation
Traffic Engineering Accident Analysis System
Strip Analysis Report**

Features	Milepost	Crash IDs
	28.88	
SR 3539 FANNING BRIDGE	28.89	
	28.90	
	28.91	
MILE MARKER	28.92	
	28.93	
	28.94	
	28.95	
	28.96	
	28.97	
	28.98	
	28.99	
	29.00	
	29.01	
	29.02	
	29.03	
	29.04	
	29.05	103387477
	29.06	
	29.07	
	29.08	
	29.09	
	29.10	
	29.11	
	29.12	
	29.13	
	29.14	
	29.15	
	29.16	
	29.17	
CL-HENDERSON CL-BUNCOMBE	29.18	
NC 280 AIRPORT NEW AIRPORT	29.19	103165066
	29.20	
	29.21	102958671 102715246
	29.22	
	29.23	102851725
	29.24	
	29.25	
	29.26	
	29.27	
	29.28	
MILE MARKER	29.29	102702419 102752304 102788754 103446738
	29.30	
	29.31	
	29.32	
	29.33	

**North Carolina Department of Transportation
Traffic Engineering Accident Analysis System
Strip Analysis Report**

Features	Milepost	Crash IDs
	29.34	
	29.35	102658373
	29.36	
	29.37	
	29.38	
	29.39	103319257
	29.40	
	29.41	
	29.42	
	29.43	
	29.44	
	29.45	
	29.46	
	29.47	
	29.48	103382395
	29.49	
	29.50	
CL-BUNCOMBE	29.51	
	29.52	
	29.53	
	29.54	
	29.55	
	29.56	
	29.57	
	29.58	
	29.59	102931874 103182009 103191109
	29.60	
	29.61	
	29.62	
	29.63	
	29.64	
	29.65	
	29.66	
MILE MARKER	29.67	
	29.68	103327922
	29.69	102679302 103446752
	29.70	103443962
	29.71	
	29.72	
	29.73	
	29.74	
	29.75	
	29.76	
	29.77	
	29.78	
	29.79	102863908 103388068

**North Carolina Department of Transportation
Traffic Engineering Accident Analysis System
Strip Analysis Report**

Features	Milepost	Crash IDs
SR 1358 SR 1419	29.80	
	29.81	
	29.82	102769803
	29.83	
	29.84	
	29.85	
	29.86	
	29.87	103363756
	29.88	
	29.89	103504879
	29.90	103137826
	29.91	
	29.92	
	29.93	
	29.94	
	29.95	
	29.96	
	29.97	
	29.98	
	29.99	102695101
	30.00	102804230
	30.01	
	30.02	
	30.03	
30.04		
30.05		
30.06		
30.07	103169286	
30.08		
30.09		
CL-BUNCOMBE	30.10	103311591
	30.11	
	30.12	
	30.13	
	30.14	
	30.15	
	30.16	
	30.17	
	30.18	102895661
	30.19	103087764 103437449 103439542
	30.20	103503856
	30.21	102908580
	30.22	
	30.23	
	30.24	

**North Carolina Department of Transportation
Traffic Engineering Accident Analysis System
Strip Analysis Report**

Features	Milepost	Crash IDs
	30.25	
	30.26	
	30.27	
	30.28	
MILE MARKER	30.29	
	30.30	103214926
	30.31	
	30.32	
	30.33	
	30.34	
	30.35	
	30.36	
	30.37	
	30.38	
	30.39	
	30.40	
	30.41	
	30.42	
	30.43	
	30.44	
	30.45	
	30.46	
	30.47	102788203 102901423 103052575 103052776 103487076
	30.48	
	30.49	102709818 103437439
	30.50	103196332
	30.51	
	30.52	
	30.53	
	30.54	103338865
	30.55	
	30.56	
	30.57	
	30.58	103416523
	30.59	103437361
	30.60	102916838
	30.61	
	30.62	
STRUCTURE	30.63	102941559
	30.64	102882876
	30.65	
	30.66	
MILE MARKER	30.67	
	30.68	

**North Carolina Department of Transportation
Traffic Engineering Accident Analysis System
Strip Analysis Report**

Features	Milepost	Crash IDs
	30.69	
	30.70	
	30.71	
	30.72	
	30.73	
	30.74	102920329
	30.75	
	30.76	
	30.77	
	30.78	
	30.79	
	30.80	103403598
	30.81	
	30.82	
	30.83	
	30.84	
	30.85	
	30.86	
	30.87	
	30.88	
	30.89	
	30.90	
	30.91	
	30.92	
	30.93	
	30.94	
	30.95	
	30.96	
	30.97	103288098
	30.98	
STRUCTURE	30.99	102705479
	31.00	
	31.01	
	31.02	
	31.03	
	31.04	
	31.05	
	31.06	
	31.07	
	31.08	
	31.09	
	31.10	
	31.11	
	31.12	
	31.13	
	31.14	102783526

**North Carolina Department of Transportation
Traffic Engineering Accident Analysis System
Strip Analysis Report**

Features	Milepost	Crash IDs
	31.15	
	31.16	
	31.17	103214577
	31.18	
	31.19	103178059
	31.20	
	31.21	
	31.22	
	31.23	
	31.24	
	31.25	
	31.26	
	31.27	
	31.28	
MILE MARKER	31.29	
	31.30	103342509
	31.31	
	31.32	
	31.33	
	31.34	
	31.35	
	31.36	
	31.37	
	31.38	
	31.39	102994865
	31.40	102821369
	31.41	
	31.42	
	31.43	
	31.44	103175854 103329902
	31.45	
	31.46	
	31.47	102694231
	31.48	
	31.49	
	31.50	
	31.51	
	31.52	
	31.53	
	31.54	
	31.55	
	31.56	
	31.57	
	31.58	
	31.59	
	31.60	

**North Carolina Department of Transportation
Traffic Engineering Accident Analysis System
Strip Analysis Report**

Features	Milepost	Crash IDs
	31.61	
	31.62	
	31.63	
	31.64	
	31.65	
	31.66	
MILE MARKER	31.67	
	31.68	
	31.69	
	31.70	
	31.71	
	31.72	
	31.73	
	31.74	
	31.75	
	31.76	
	31.77	
	31.78	
	31.79	
	31.80	
	31.81	
	31.82	103490750
	31.83	102959839
SR 1345 BUTLER BRIDGE	31.84	103012561 103130245
	31.85	
	31.86	102891672
	31.87	103491013
	31.88	
	31.89	
	31.90	
	31.91	
	31.92	
	31.93	
	31.94	102847555
	31.95	
	31.96	
	31.97	103468825 103483074
	31.98	
	31.99	
	32.00	
	32.01	
	32.02	
	32.03	
	32.04	
	32.05	
	32.06	

**North Carolina Department of Transportation
Traffic Engineering Accident Analysis System
Strip Analysis Report**

Features	Milepost	Crash IDs
	32.07	102996145 103504546
	32.08	
	32.09	102722835
	32.10	
	32.11	
	32.12	
	32.13	
	32.14	102753540
	32.15	
	32.16	
	32.17	102677565
	32.18	
	32.19	
	32.20	
	32.21	
	32.22	
	32.23	
	32.24	
	32.25	
	32.26	
	32.27	
	32.28	103344026
MILE MARKER	32.29	102751082 103012570
	32.30	
	32.31	
	32.32	
	32.33	
	32.34	
	32.35	
	32.36	
	32.37	102720347 102808822 102928095 103129978 103344949 103486791
	32.38	
	32.39	103458599
	32.40	
	32.41	
	32.42	
	32.43	102914530
	32.44	
	32.45	
	32.46	
US 25 US 25BUS EXIT 44	32.47	
	32.48	103076325
	32.49	103488200
	32.50	

**North Carolina Department of Transportation
Traffic Engineering Accident Analysis System
Strip Analysis Report**

Features	Milepost	Crash IDs
	32.51	
	32.52	103219475
	32.53	
	32.54	102873706
	32.55	
	32.56	
	32.57	102670250 102911213
	32.58	
STRUCTURE	32.59	102659354 102739389 102997017 103313567 103343042
	32.60	
	32.61	
	32.62	
	32.63	
	32.64	
	32.65	
	32.66	
MILE MARKER	32.67	102695330 103120998 103179669 103344007
	32.68	
	32.69	103481677
	32.70	
	32.71	
	32.72	
	32.73	103094201
	32.74	
	32.75	
	32.76	
	32.77	
	32.78	
	32.79	102742836
	32.80	
	32.81	
	32.82	
	32.83	
	32.84	
	32.85	
	32.86	
	32.87	
	32.88	
	32.89	
	32.90	
	32.91	
	32.92	
	32.93	103247552
	32.94	
	32.95	

**North Carolina Department of Transportation
Traffic Engineering Accident Analysis System
Strip Analysis Report**

Features	Milepost	Crash IDs
	32.96	
	32.97	
	32.98	
	32.99	
	33.00	
	33.01	
	33.02	
	33.03	
	33.04	
	33.05	
	33.06	
	33.07	102664964
	33.08	
	33.09	
	33.10	
	33.11	
	33.12	
SR 1534 NAPLE	33.13	102995873 102996079
	33.14	
	33.15	
	33.16	
	33.17	
	33.18	
	33.19	102731707 102942919 103504005
	33.20	
	33.21	
	33.22	
	33.23	103191204
	33.24	
	33.25	
	33.26	
	33.27	
	33.28	
MILE MARKER	33.29	103298200 103214385
	33.30	
	33.31	
	33.32	
	33.33	
	33.34	
	33.35	
	33.36	
	33.37	
	33.38	
	33.39	102650709
	33.40	
	33.41	

**North Carolina Department of Transportation
Traffic Engineering Accident Analysis System
Strip Analysis Report**

Features	Milepost	Crash IDs
	33.42	
	33.43	102871087
	33.44	
	33.45	
	33.46	
	33.47	
	33.48	
	33.49	102749717 103259032 103253809
	33.50	
	33.51	
	33.52	
	33.53	
	33.54	
	33.55	
	33.56	
	33.57	
	33.58	
	33.59	102792360 103488210
	33.60	
	33.61	
	33.62	
	33.63	
	33.64	
	33.65	
	33.66	
MILE MARKER	33.67	
	33.68	
	33.69	102696620
	33.70	
	33.71	
	33.72	
	33.73	
	33.74	
	33.75	
	33.76	
	33.77	
	33.78	
	33.79	102723434 102991507
	33.80	
	33.81	
	33.82	
	33.83	
	33.84	
	33.85	
	33.86	
	33.87	

**North Carolina Department of Transportation
Traffic Engineering Accident Analysis System
Strip Analysis Report**

Features	Milepost	Crash IDs
	33.88	
	33.89	
	33.90	
	33.91	
	33.92	103344038
	33.93	
	33.94	
	33.95	
	33.96	
	33.97	
	33.98	
	33.99	103299037
	34.00	
	34.01	
	34.02	103106992
	34.03	
	34.04	
	34.05	
	34.06	
	34.07	
	34.08	
	34.09	102709091
	34.10	
	34.11	
	34.12	
	34.13	
	34.14	
	34.15	
	34.16	
	34.17	
	34.18	
	34.19	102996172
	34.20	
	34.21	
	34.22	
	34.23	
	34.24	
	34.25	
	34.26	
	34.27	
	34.28	
MILE MARKER	34.29	
	34.30	
	34.31	
	34.32	103470190
	34.33	

**North Carolina Department of Transportation
Traffic Engineering Accident Analysis System
Strip Analysis Report**

Features	Milepost	Crash IDs
	34.34	
	34.35	
	34.36	
	34.37	
	34.38	
	34.39	102683616
	34.40	
	34.41	
	34.42	
	34.43	
	34.44	
	34.45	
	34.46	
	34.47	102927064
	34.48	
	34.49	103331847 103255423
	34.50	
	34.51	
	34.52	102702791 103067779
	34.53	
	34.54	
	34.55	
	34.56	
	34.57	
	34.58	
	34.59	
	34.60	
	34.61	
	34.62	103507427
	34.63	
	34.64	
	34.65	
	34.66	
MILE MARKER	34.67	
	34.68	
	34.69	102742654
	34.70	
	34.71	
	34.72	103487809
	34.73	
	34.74	
	34.75	
	34.76	
	34.77	
	34.78	
	34.79	

**North Carolina Department of Transportation
Traffic Engineering Accident Analysis System
Strip Analysis Report**

Features	Milepost	Crash IDs
	34.80	
	34.81	
	34.82	102991488 103191179
	34.83	
	34.84	
	34.85	
	34.86	
	34.87	
	34.88	
	34.89	102750366
	34.90	
	34.91	
	34.92	102785514 102862174 103167305 103277206 103359108
	34.93	
	34.94	
	34.95	
	34.96	
	34.97	
	34.98	
	34.99	102697634 103344027
	35.00	
	35.01	
SR 1528 BROOKSIDE BROOKSIDE CAMP	35.02	103046784
	35.03	
	35.04	
	35.05	
	35.06	103344008
	35.07	
	35.08	
	35.09	
	35.10	
	35.11	
	35.12	
	35.13	
	35.14	
	35.15	
	35.16	
	35.17	
	35.18	
	35.19	
	35.20	
	35.21	
STRUCTURE	35.22	102981261 103181970
	35.23	
	35.24	

**North Carolina Department of Transportation
Traffic Engineering Accident Analysis System
Strip Analysis Report**

Features	Milepost	Crash IDs
	35.25	
	35.26	
	35.27	
	35.28	
MILE MARKER	35.29	103438528 103467845 102809274
	35.30	
	35.31	
	35.32	
	35.33	
	35.34	
	35.35	
	35.36	
	35.37	
	35.38	
	35.39	102666316
	35.40	
	35.41	
	35.42	103319255
	35.43	
	35.44	
	35.45	
	35.46	
	35.47	
	35.48	
	35.49	102980619 103252916
	35.50	
	35.51	
	35.52	
	35.53	
	35.54	
	35.55	
	35.56	
	35.57	
	35.58	
	35.59	102984916 103151696
	35.60	
	35.61	
	35.62	
	35.63	
	35.64	
	35.65	
	35.66	
MILE MARKER	35.67	
	35.68	
	35.69	102980639
	35.70	

**North Carolina Department of Transportation
Traffic Engineering Accident Analysis System
Strip Analysis Report**

Features	Milepost	Crash IDs
	35.71	
	35.72	
	35.73	
	35.74	
	35.75	
	35.76	
	35.77	
	35.78	
	35.79	
	35.80	
	35.81	
	35.82	102892098
	35.83	
	35.84	
	35.85	
	35.86	
	35.87	
	35.88	
	35.89	102980616 102980615
	35.90	
	35.91	
	35.92	
	35.93	102675407 103238240
	35.94	
	35.95	
	35.96	
	35.97	
	35.98	
	35.99	
	36.00	
	36.01	
	36.02	
	36.03	102721151
	36.04	
	36.05	
	36.06	
	36.07	
	36.08	
	36.09	
	36.10	
	36.11	
	36.12	
	36.13	
	36.14	
	36.15	
	36.16	

**North Carolina Department of Transportation
Traffic Engineering Accident Analysis System
Strip Analysis Report**

Features	Milepost	Crash IDs
	36.17	
	36.18	
	36.19	102776784
	36.20	
	36.21	
	36.22	
	36.23	
	36.24	
	36.25	
	36.26	
	36.27	
	36.28	
MILE MARKER	36.29	
	36.30	
	36.31	
	36.32	
	36.33	102882371
	36.34	
	36.35	
	36.36	
	36.37	
	36.38	
	36.39	102746180 103471637
	36.40	
	36.41	
	36.42	
	36.43	
	36.44	
	36.45	
	36.46	
	36.47	
	36.48	
	36.49	
	36.50	
	36.51	
	36.52	
	36.53	
	36.54	
	36.55	
	36.56	
	36.57	
	36.58	
	36.59	
	36.60	
	36.61	
	36.62	

**North Carolina Department of Transportation
Traffic Engineering Accident Analysis System
Strip Analysis Report**

Features	Milepost	Crash IDs
	36.63	103510385
	36.64	
	36.65	
	36.66	
MILE MARKER	36.67	
	36.68	
	36.69	102846943
	36.70	
	36.71	
	36.72	
	36.73	102881191 103434784
	36.74	
	36.75	
	36.76	
	36.77	
	36.78	
	36.79	102873386
	36.80	
	36.81	
	36.82	
	36.83	
	36.84	
	36.85	
	36.86	
	36.87	
	36.88	
	36.89	103400750
	36.90	
	36.91	
	36.92	
SR 1503 CLEAR CREEK	36.93	
	36.94	
	36.95	
	36.96	
	36.97	
	36.98	
	36.99	
	37.00	
	37.01	
	37.02	
	37.03	
	37.04	
	37.05	
	37.06	
	37.07	
	37.08	

**North Carolina Department of Transportation
Traffic Engineering Accident Analysis System
Strip Analysis Report**

Features	Milepost	Crash IDs
	37.09	
	37.10	
	37.11	
	37.12	
	37.13	
	37.14	
	37.15	
	37.16	
	37.17	
	37.18	
	37.19	102780622 103358944 103420164 102860747 103155943
	37.20	
	37.21	
	37.22	
	37.23	
STRUCTURE	37.24	
	37.25	
	37.26	
	37.27	
	37.28	
MILE MARKER	37.29	102791635 102957265 103119053 103125969
	37.30	
	37.31	
	37.32	
	37.33	
	37.34	
	37.35	
	37.36	
	37.37	
	37.38	
	37.39	103366441
	37.40	
	37.41	
	37.42	
	37.43	102937163
	37.44	
	37.45	
	37.46	
	37.47	
	37.48	
	37.49	102926201 102653823 103051133 103420155
	37.50	
	37.51	
	37.52	
	37.53	

**North Carolina Department of Transportation
Traffic Engineering Accident Analysis System
Strip Analysis Report**

Features	Milepost	Crash IDs
	37.54	
	37.55	
	37.56	
	37.57	
	37.58	
	37.59	103269919
	37.60	
	37.61	
	37.62	
	37.63	
	37.64	
	37.65	
	37.66	
MILE MARKER	37.67	
	37.68	
	37.69	103189842
	37.70	
	37.71	
	37.72	
	37.73	
ML-HENDERSONVILLE	37.74	
	37.75	
	37.76	
	37.77	
	37.78	
	37.79	
	37.80	
	37.81	
	37.82	
	37.83	
	37.84	
	37.85	
	37.86	
	37.87	
	37.88	
	37.89	103437451
	37.90	
	37.91	
	37.92	
	37.93	
	37.94	
	37.95	
	37.96	
	37.97	
	37.98	
	37.99	103170318 103237124

**North Carolina Department of Transportation
Traffic Engineering Accident Analysis System
Strip Analysis Report**

Features	Milepost	Crash IDs
	38.00	
	38.01	
	38.02	
	38.03	
	38.04	
	38.05	
	38.06	
	38.07	
	38.08	
	38.09	102695098 102748673 102756622 102993228 103050922 103156857 103191451
	38.10	
	38.11	
	38.12	
	38.13	
	38.14	
	38.15	102832732
	38.16	
	38.17	102971405
	38.18	
US 64 FOUR SEASONS EXIT 49	38.19	103078504 103269718 103334218
	38.20	102791535 103504877
	38.21	
	38.22	
	38.23	102677930
	38.24	103229766
	38.25	
	38.26	
	38.27	
	38.28	
MILE MARKER	38.29	103042733 102669364 102822401 102833360 102891993 102892042 103241764 103420159 103471075
	38.30	
	38.31	
	38.32	
	38.33	
	38.34	
	38.35	
	38.36	
	38.37	
	38.38	
ML-HENDERSONVILLE	38.39	102652189 102811780 103059268
	38.40	
	38.41	

**North Carolina Department of Transportation
Traffic Engineering Accident Analysis System
Strip Analysis Report**

Features	Milepost	Crash IDs
	38.42	
	38.43	
	38.44	
	38.45	
	38.46	
	38.47	
	38.48	
	38.49	102705536
	38.50	
	38.51	
	38.52	
	38.53	
	38.54	
	38.55	
	38.56	
	38.57	
	38.58	
	38.59	103476067
	38.60	
	38.61	
	38.62	
	38.63	
	38.64	
	38.65	
	38.66	
MILE MARKER	38.67	
	38.68	
	38.69	103454485 102993235
	38.70	
	38.71	
	38.72	
	38.73	
	38.74	
	38.75	
	38.76	
	38.77	
	38.78	
	38.79	
	38.80	
	38.81	
	38.82	
	38.83	
	38.84	
	38.85	
	38.86	
	38.87	

**North Carolina Department of Transportation
Traffic Engineering Accident Analysis System
Strip Analysis Report**

Features	Milepost	Crash IDs
	38.88	
	38.89	103258735
	38.90	
	38.91	
	38.92	
	38.93	
	38.94	
	38.95	
	38.96	
	38.97	
	38.98	
	38.99	103069048
	39.00	
	39.01	
	39.02	
	39.03	
	39.04	
	39.05	
	39.06	
	39.07	
	39.08	
	39.09	102898766
	39.10	
	39.11	
	39.12	
	39.13	
	39.14	
	39.15	
	39.16	
	39.17	
	39.18	
	39.19	102656178 102808755
	39.20	
	39.21	
	39.22	
	39.23	
	39.24	
SR 1525 DANA	39.25	
	39.26	102826278
	39.27	
	39.28	
MILE MARKER	39.29	
	39.30	
	39.31	
	39.32	
	39.33	

**North Carolina Department of Transportation
Traffic Engineering Accident Analysis System
Strip Analysis Report**

Features	Milepost	Crash IDs
	39.34	
	39.35	
	39.36	
	39.37	
	39.38	
	39.39	
	39.40	
	39.41	
	39.42	
	39.43	
	39.44	
	39.45	
	39.46	
	39.47	
	39.48	
	39.49	
	39.50	
	39.51	
	39.52	
	39.53	
	39.54	
	39.55	
	39.56	
	39.57	
	39.58	
	39.59	103146175
	39.60	
	39.61	
	39.62	
	39.63	
	39.64	
	39.65	
	39.66	
MILE MARKER	39.67	
	39.68	
	39.69	
	39.70	
	39.71	
	39.72	
	39.73	
	39.74	
	39.75	103408612
	39.76	
	39.77	
	39.78	
	39.79	

**North Carolina Department of Transportation
Traffic Engineering Accident Analysis System
Strip Analysis Report**

Features	Milepost	Crash IDs
	39.80	
	39.81	
	39.82	
	39.83	
	39.84	
	39.85	
	39.86	
	39.87	
STRUCTURE	39.88	
	39.89	102784702
	39.90	
	39.91	
	39.92	
	39.93	
	39.94	
	39.95	102987438
	39.96	103208602 103303891
	39.97	
	39.98	
	39.99	
	40.00	
	40.01	
	40.02	
	40.03	
	40.04	
	40.05	
	40.06	102958425
	40.07	
	40.08	
	40.09	
	40.10	
	40.11	
	40.12	
	40.13	
	40.14	
	40.15	
	40.16	
	40.17	
	40.18	
	40.19	103103232 103143177 103025809
	40.20	
	40.21	
	40.22	
	40.23	
	40.24	103346974
	40.25	

**North Carolina Department of Transportation
Traffic Engineering Accident Analysis System
Strip Analysis Report**

Features	Milepost	Crash IDs
SR 1793 TRACY GROVE	40.26	103023425
	40.27	102885107
	40.28	
MILE MARKER	40.29	103226615
	40.30	
	40.31	
	40.32	
	40.33	
	40.34	
	40.35	
	40.36	103287600
	40.37	
	40.38	
	40.39	102675485
	40.40	
	40.41	
	40.42	
	40.43	
	40.44	102832396
	40.45	
	40.46	102729487
	40.47	
	40.48	
	40.49	
	40.50	
	40.51	
	40.52	
	40.53	
	40.54	103025094
	40.55	
	40.56	
	40.57	
	40.58	
40.59	102963049	
40.60		
40.61		
40.62		
40.63		
40.64	102913030	
40.65		
40.66	102832199	
MILE MARKER	40.67	
	40.68	
	40.69	
	40.70	

**North Carolina Department of Transportation
Traffic Engineering Accident Analysis System
Strip Analysis Report**

Features	Milepost	Crash IDs
	40.71	
	40.72	
	40.73	
	40.74	103491711
	40.75	103410046
	40.76	
	40.77	
	40.78	
	40.79	102698762 103138546
	40.80	
	40.81	
	40.82	
	40.83	
	40.84	103405457
	40.85	
	40.86	
	40.87	
	40.88	
	40.89	103234336 103461858
	40.90	
	40.91	
	40.92	
	40.93	
	40.94	
	40.95	
	40.96	
	40.97	
	40.98	
	40.99	
	41.00	
	41.01	
	41.02	
	41.03	
	41.04	
	41.05	
	41.06	102800891 103227817
	41.07	
	41.08	
	41.09	
	41.10	
	41.11	
	41.12	
	41.13	
	41.14	
	41.15	
	41.16	

**North Carolina Department of Transportation
Traffic Engineering Accident Analysis System
Strip Analysis Report**

Features	Milepost	Crash IDs
	41.17	
	41.18	102666228
	41.19	102967173
	41.20	
	41.21	
	41.22	
	41.23	
	41.24	103059257
	41.25	
	41.26	
	41.27	
	41.28	
MILE MARKER	41.29	
	41.30	
	41.31	
	41.32	
	41.33	
	41.34	103179409
	41.35	
	41.36	
	41.37	
	41.38	
	41.39	
	41.40	
	41.41	
	41.42	
	41.43	
	41.44	103292103 103391145 103497359
	41.45	
	41.46	
	41.47	
	41.48	
	41.49	
	41.50	
	41.51	
	41.52	
	41.53	
	41.54	102860751 103025073
	41.55	
	41.56	
	41.57	
	41.58	
	41.59	103059330
	41.60	
	41.61	
	41.62	

**North Carolina Department of Transportation
Traffic Engineering Accident Analysis System
Strip Analysis Report**

Features	Milepost	Crash IDs
	41.63	
	41.64	102799654 102868317 102952718 103139202 103287277
	41.65	
	41.66	
MILE MARKER	41.67	
	41.68	102912757
	41.69	
	41.70	
	41.71	
	41.72	
	41.73	
SR 1783 UPWARD EXIT 53	41.74	103194536 103419851 103427118
	41.75	
	41.76	102789185
	41.77	
	41.78	
	41.79	103448937
	41.80	
STRUCTURE	41.81	103200588
	41.82	
	41.83	
	41.84	102808831 102881841
	41.85	
	41.86	
	41.87	
	41.88	
	41.89	
	41.90	
	41.91	
	41.92	
	41.93	
	41.94	102875260
	41.95	
	41.96	
	41.97	
	41.98	
	41.99	
	42.00	
	42.01	
	42.02	
	42.03	
	42.04	
	42.05	
	42.06	

**North Carolina Department of Transportation
Traffic Engineering Accident Analysis System
Strip Analysis Report**

Features	Milepost	Crash IDs
	42.07	
	42.08	
	42.09	103431809 103508019
	42.10	
	42.11	
	42.12	
	42.13	
	42.14	103485462
	42.15	
	42.16	
	42.17	
	42.18	
	42.19	
	42.20	
	42.21	
	42.22	
	42.23	
	42.24	103134867 103311178 103496707
	42.25	
	42.26	
	42.27	
	42.28	
MILE MARKER	42.29	103232141
	42.30	
	42.31	
	42.32	
	42.33	
SR 1803 CREST	42.34	
	42.35	
	42.36	
	42.37	102797502 103287588
	42.38	
	42.39	
	42.40	103202027
	42.41	
	42.42	
	42.43	
	42.44	
	42.45	
	42.46	
	42.47	
	42.48	103184223
	42.49	
	42.50	
	42.51	
	42.52	

**North Carolina Department of Transportation
Traffic Engineering Accident Analysis System
Strip Analysis Report**

Features	Milepost	Crash IDs
	42.53	
	42.54	103205217 103263132
	42.55	
	42.56	
	42.57	
	42.58	
	42.59	
	42.60	
	42.61	
	42.62	
	42.63	
	42.64	102824778
	42.65	
	42.66	
MILE MARKER	42.67	
	42.68	
	42.69	
	42.70	
	42.71	
	42.72	
	42.73	
	42.74	102816806 103151458
	42.75	
	42.76	
	42.77	
	42.78	102912921
	42.79	
	42.80	102754734
	42.81	
	42.82	
	42.83	
US 25 NC 225 EXIT 54	42.84	
	42.85	
	42.86	
	42.87	
	42.88	
	42.89	
	42.90	
	42.91	
	42.92	
	42.93	
	42.94	102741575 102751080 102938146 103423626 103458822
	42.95	
	42.96	
	42.97	

**North Carolina Department of Transportation
Traffic Engineering Accident Analysis System
Strip Analysis Report**

Features	Milepost	Crash IDs
	42.98	
	42.99	
	43.00	
	43.01	
	43.02	
	43.03	
	43.04	
	43.05	
	43.06	
	43.07	
	43.08	
	43.09	
	43.10	
	43.11	
	43.12	
	43.13	
	43.14	
	43.15	
	43.16	
	43.17	
	43.18	
	43.19	
	43.20	
	43.21	
	43.22	
	43.23	
	43.24	102677339 102766977 103367276
	43.25	
	43.26	
	43.27	
	43.28	
MILE MARKER	43.29	
	43.30	
	43.31	
	43.32	
	43.33	
	43.34	102667757 102685431 103375555
	43.35	
	43.36	
	43.37	
	43.38	
	43.39	103050056
	43.40	
	43.41	
	43.42	
	43.43	

**North Carolina Department of Transportation
Traffic Engineering Accident Analysis System
Strip Analysis Report**

Features	Milepost	Crash IDs
	43.44	102656572
	43.45	
	43.46	
	43.47	
	43.48	
	43.49	
	43.50	
	43.51	
	43.52	
	43.53	
	43.54	103283476 103312477
	43.55	
	43.56	
	43.57	
	43.58	
	43.59	
	43.60	
	43.61	
	43.62	
	43.63	
	43.64	102900780 102948114 103169377
	43.65	
MILE MARKER	43.66	
	43.67	
	43.68	
	43.69	
	43.70	
	43.71	103238704
	43.72	
	43.73	
	43.74	102903198 103087782 103447667
	43.75	
	43.76	
	43.77	
	43.78	
	43.79	
	43.80	
	43.81	
	43.82	
	43.83	
	43.84	102659227 102699243 102843904 103097194 103224433
	43.85	
	43.86	
	43.87	
	43.88	

**North Carolina Department of Transportation
Traffic Engineering Accident Analysis System
Strip Analysis Report**

Features	Milepost	Crash IDs
	43.89	
	43.90	
	43.91	
	43.92	
	43.93	
	43.94	
	43.95	
	43.96	103015987
	43.97	
	43.98	
	43.99	103319642 103348073
	44.00	
	44.01	
	44.02	
	44.03	
	44.04	
	44.05	
	44.06	
	44.07	
	44.08	
	44.09	
	44.10	
	44.11	
	44.12	
	44.13	
	44.14	102917186 103041018 103043345
	44.15	
	44.16	
	44.17	
	44.18	
	44.19	103069687
	44.20	
	44.21	
	44.22	
	44.23	
	44.24	
	44.25	
	44.26	102897667
	44.27	
	44.28	
MILE MARKER	44.29	103200907
	44.30	
	44.31	102971038
	44.32	
	44.33	
	44.34	102720317 102770275 102845940 103121267

**North Carolina Department of Transportation
Traffic Engineering Accident Analysis System
Strip Analysis Report**

Features	Milepost	Crash IDs
	44.35	
	44.36	
	44.37	
	44.38	
	44.39	
	44.40	
	44.41	
	44.42	
	44.43	
	44.44	103448860
	44.45	
	44.46	
	44.47	
	44.48	
	44.49	
	44.50	
	44.51	
	44.52	
	44.53	
STRUCTURE	44.54	102831156 102824683 102925920 103316889 103403631 103418396 103444281 103448766
	44.55	
	44.56	
	44.57	
	44.58	
	44.59	102935181
	44.60	
	44.61	
	44.62	
	44.63	
	44.64	103344006
	44.65	
	44.66	
MILE MARKER	44.67	
	44.68	
	44.69	
	44.70	
	44.71	
	44.72	
	44.73	
	44.74	102881848 103294545
	44.75	
	44.76	102871143
	44.77	
	44.78	
	44.79	102666303 102684412

**North Carolina Department of Transportation
Traffic Engineering Accident Analysis System
Strip Analysis Report**

Features	Milepost	Crash IDs
	44.80	
	44.81	
	44.82	
	44.83	
	44.84	102930226
	44.85	
	44.86	102869293 103428092
	44.87	
	44.88	
	44.89	102776658
	44.90	
	44.91	
	44.92	
	44.93	
	44.94	102958645 103002520 103497221
	44.95	
	44.96	103135072
	44.97	
	44.98	
	44.99	
	45.00	
	45.01	
	45.02	
	45.03	
	45.04	102834635
	45.05	
	45.06	
	45.07	
	45.08	
	45.09	102752190
	45.10	
	45.11	
	45.12	
	45.13	
	45.14	103476995
	45.15	
	45.16	
	45.17	
	45.18	
	45.19	103348027 103348489 103384423
	45.20	
	45.21	
	45.22	
	45.23	
	45.24	102768355
	45.25	

**North Carolina Department of Transportation
Traffic Engineering Accident Analysis System
Strip Analysis Report**

Features	Milepost	Crash IDs
	45.26	
	45.27	
	45.28	
MILE MARKER	45.29	102912982
	45.30	
	45.31	
	45.32	
	45.33	
	45.34	103179580
	45.35	
	45.36	102766986
	45.37	
	45.38	
	45.39	103165263 103312042
	45.40	
	45.41	
	45.42	
	45.43	
	45.44	
	45.45	
SR 1832 SR 1834 SR 1835 SR 1919 HOWARD GAP MACEDONIA STRUCTURE	45.46	102752950 103236077 103383408 103510268
	45.47	
	45.48	
	45.49	
	45.50	
	45.51	
	45.52	
	45.53	
	45.54	102752646
	45.55	
	45.56	
	45.57	
	45.58	
	45.59	
	45.60	
	45.61	
	45.62	
	45.63	
	45.64	
	45.65	
	45.66	
MILE MARKER	45.67	
	45.68	
	45.69	102675477
	45.70	

**North Carolina Department of Transportation
Traffic Engineering Accident Analysis System
Strip Analysis Report**

Features	Milepost	Crash IDs
	45.71	
	45.72	
	45.73	103239931
	45.74	
	45.75	
	45.76	
	45.77	
	45.78	
	45.79	
	45.80	
	45.81	
	45.82	
	45.83	
	45.84	102878491 103374810
	45.85	
	45.86	
	45.87	
	45.88	
	45.89	
	45.90	
	45.91	
	45.92	
	45.93	
	45.94	
	45.95	
	45.96	102937502
	45.97	
	45.98	
	45.99	103185862
	46.00	
	46.01	
	46.02	
	46.03	
	46.04	
	46.05	
	46.06	103192690
	46.07	
	46.08	
	46.09	103500600
	46.10	
	46.11	
	46.12	
	46.13	
	46.14	103265593
	46.15	
	46.16	

**North Carolina Department of Transportation
Traffic Engineering Accident Analysis System
Strip Analysis Report**

Features	Milepost	Crash IDs
	46.17	
	46.18	
	46.19	102918535
	46.20	
	46.21	
	46.22	
	46.23	
	46.24	
	46.25	
	46.26	
	46.27	
	46.28	
MILE MARKER	46.29	102927106
	46.30	
	46.31	
	46.32	
	46.33	
	46.34	102747178 103272096 103369874
	46.35	
	46.36	
	46.37	
	46.38	
	46.39	
	46.40	
	46.41	
	46.42	
	46.43	
	46.44	
	46.45	
	46.46	
	46.47	
	46.48	
	46.49	
	46.50	
	46.51	
	46.52	
	46.53	
	46.54	103205241
	46.55	
	46.56	
	46.57	
	46.58	
	46.59	103299957
	46.60	
	46.61	
	46.62	

**North Carolina Department of Transportation
Traffic Engineering Accident Analysis System
Strip Analysis Report**

Features	Milepost	Crash IDs
	46.63	
	46.64	
	46.65	
	46.66	
MILE MARKER	46.67	
	46.68	
CL-POLK	46.69	103179553
	46.70	
	46.71	
	46.72	
SR 1183 SR 1918 HOWARD GAP	46.73	
	46.74	
	46.75	
	46.76	
	46.77	
	46.78	
	46.79	
	46.80	
	46.81	
	46.82	
	46.83	
	46.84	103053363
	46.85	
	46.86	
	46.87	
	46.88	
	46.89	
	46.90	
	46.91	
	46.92	
	46.93	
	46.94	
	46.95	
	46.96	
	46.97	
	46.98	
	46.99	
	47.00	103369751
	47.01	
	47.02	
	47.03	
	47.04	
	47.05	
	47.06	
	47.07	
	47.08	

North Carolina Department of Transportation
Traffic Engineering Accident Analysis System
Strip Analysis Report

Features	Milepost	Crash IDs
	47.09	
	47.10	
	47.11	
	47.12	
	47.13	
	47.14	
	47.15	
	47.16	
	47.17	
	47.18	
	47.19	
	47.20	
	47.21	
	47.22	
	47.23	
	47.24	
	47.25	
	47.26	
	47.27	
	47.28	
	47.29	
	47.30	
	47.31	
	47.32	
	47.33	
	47.34	
	47.35	
	47.36	
	47.37	
	47.38	
	47.39	
	47.40	
	47.41	
	47.42	
	47.43	
	47.44	
	47.45	
	47.46	
	47.47	
	47.48	
	47.49	
	47.50	
	47.51	
	47.52	
	47.53	
	47.54	
	47.55	

North Carolina Department of Transportation
Traffic Engineering Accident Analysis System
Strip Analysis Report

Features	Milepost	Crash IDs
	47.56	
	47.57	
	47.58	
	47.59	
	47.60	
	47.61	
	47.62	
	47.63	
	47.64	
	47.65	
	47.66	
	47.67	
	47.68	
	47.69	
	47.70	
	47.71	
	47.72	
	47.73	
	47.74	
	47.75	
	47.76	
	47.77	
	47.78	
	47.79	
	47.80	
	47.81	103373442
	47.82	
	47.83	
	47.84	
	47.85	
	47.86	
	47.87	
	47.88	
	47.89	
	47.90	
	47.91	
	47.92	
	47.93	
	47.94	
	47.95	
	47.96	
	47.97	
	47.98	
	47.99	
SR 1142 CL-HENDERSON	48.00	
	48.01	

**North Carolina Department of Transportation
Traffic Engineering Accident Analysis System
Strip Analysis Report**

Features	Milepost	Crash IDs
	48.02	
	48.03	
SR 1183 HOWARD GAP	48.04	
	48.05	
	48.06	
	48.07	
	48.08	
	48.09	
	48.10	
	48.11	
	48.12	
	48.13	
	48.14	102837471
	48.15	
	48.16	
	48.17	
	48.18	
	48.19	103506426
	48.20	102710289 103025008
MILE MARKER	48.21	
	48.22	
	48.23	
	48.24	
	48.25	
	48.26	
	48.27	
	48.28	
	48.29	
	48.30	
	48.31	
	48.32	
	48.33	
	48.34	
	48.35	
	48.36	
	48.37	
	48.38	
	48.39	
	48.40	
	48.41	
	48.42	
	48.43	
	48.44	
	48.45	
	48.46	
	48.47	

**North Carolina Department of Transportation
Traffic Engineering Accident Analysis System
Strip Analysis Report**

Features	Milepost	Crash IDs
	48.48	
	48.49	103185952
	48.50	
	48.51	
	48.52	
	48.53	
	48.54	102837472
	48.55	
	48.56	
	48.57	
	48.58	
	48.59	
	48.60	103404414
	48.61	
	48.62	
	48.63	
	48.64	
	48.65	
	48.66	
	48.67	103417606
	48.68	
MILE MARKER	48.69	
	48.70	103420103
	48.71	
	48.72	102800545
	48.73	
	48.74	
	48.75	
	48.76	
	48.77	
	48.78	
	48.79	102888231
	48.80	
	48.81	103037631
	48.82	
	48.83	
	48.84	
	48.85	
	48.86	
	48.87	
	48.88	
	48.89	
	48.90	
	48.91	
	48.92	
	48.93	

**North Carolina Department of Transportation
Traffic Engineering Accident Analysis System
Strip Analysis Report**

Features	Milepost	Crash IDs
	48.94	
	48.95	
	48.96	
	48.97	
	48.98	
	48.99	
	49.00	
	49.01	102784469
	49.02	
	49.03	
	49.04	
	49.05	
	49.06	
	49.07	
	49.08	
	49.09	
	49.10	
	49.11	
	49.12	
	49.13	
	49.14	
	49.15	
	49.16	
	49.17	
	49.18	
	49.19	
	49.20	102952655
	49.21	102752870 102877653 103093999 103318660
MILE MARKER	49.22	
	49.23	
	49.24	
	49.25	
	49.26	
	49.27	
	49.28	
	49.29	
	49.30	
SR 1142 HOLBERT COVE OZONE STRUCTURE	49.31	103315737

**North Carolina Department of Transportation
Traffic Engineering Accident Analysis System
Strip Analysis Report**

Study Criteria

Study Name	Log No.	PH No.	TIP No.	K/A Cf.	B/C Cf.	ADT	ADT Route
I4400UPDATE			I4700	76.8	8.4	58000	

Request Date	Courier Service	Phone No.	Ext.	Fax No.

County			Municipality						
Name	Code	Div.	Name	Code	Y-Line Ft.	Begin Date	End Date	Years	
BUNCOMBE	10	13	All and Rural		150	8/1/2009	7/31/2012	3.00	

Location Text	Requestor
I-26-US 74 from I-40 interchange in Buncombe County through Henderson County to SR 1142-Holbert Cove Rd in Polk County	Elise Groundwater Congestion Management

Included Accidents	Old MP	New MP	Type
103346360		18.959	I
103032037		18.965	I
102789500		18.988	I
103502976		19.007	I
103162626		19.01	I
103425156		19.05	I
102894961		19.05	I
103483107		19.05	I
103106332		19.05	I
103382120		19.05	I
102705375		19.15	I
102683889		19.15	I
102698879		19.15	I
103316308		19.15	I
103429664		19.19	I
102988220		19.2	I
102800065		19.2	I
103499265		19.25	I
103197337		19.25	I
103219739		19.25	I
102708121		19.3	I
102950515		19.393	I
102850417		19.4	I
103026612		19.42	I
103388471		19.45	I
103324320		19.45	I

**North Carolina Department of Transportation
Traffic Engineering Accident Analysis System
Strip Analysis Report**

103324329	19.45	I
103302517	19.45	I
102863083	19.45	I
103035366	19.45	I
103229786	19.456	I
102711532	19.47	I
103162663	19.48	I
103406972	19.5	I
102929299	19.51	I
102802570	19.51	I
102684237	19.51	I
103434652	19.51	I
103193167	19.51	I
102963837	19.51	I
103509868	19.6	I
102686217	19.62	I
103233826	19.65	I
103254981	19.65	I
103114693	19.65	I
102984230	19.81	I
103412884	19.95	I
103396041	19.95	I
102959180	19.95	I
103396064	19.95	I
103396062	19.95	I
103153037	19.95	I
103455000	19.95	I
102924612	20.01	I
102956037	20.01	I
103228625	20.01	I
102992638	20.1	I
102984238	20.12	I
103245113	20.2	I
102684228	20.21	I
102822984	20.21	I
102855182	20.25	I
103230678	20.26	I
102950229	20.26	I
103345638	20.3	I
102850411	20.31	I
103213665	20.31	I

**North Carolina Department of Transportation
Traffic Engineering Accident Analysis System
Strip Analysis Report**

102796195	20.31	I
103418254	20.31	I
102835071	20.31	I
103403644	20.32	I
103316375	20.34	I
103223969	20.41	I
103503359	20.41	I
103472140	20.41	I
103378055	20.41	I
102900239	20.41	I
103369147	20.42	I
103179347	20.42	I
103219755	20.425	I
103058761	20.45	I
102843045	20.45	I
103219754	20.482	I
102799999	20.491	I
103215134	20.491	I
103164481	20.491	I
103021891	20.491	I
102855859	20.51	I
103519490	20.51	I
103506986	20.51	I
103229336	20.51	I
103219752	20.51	I
103179036	20.51	I
103162668	20.51	I
103114696	20.51	I
102683643	20.51	I
103369153	20.51	I
103511035	20.51	I
102840444	20.52	I
102962178	20.52	I
103145474	20.521	I
102850445	20.529	I
102950781	20.529	I
103187239	20.548	I
102683901	20.548	I
102968573	20.548	I
102659772	20.567	I
102947016	20.586	I

**North Carolina Department of Transportation
Traffic Engineering Accident Analysis System
Strip Analysis Report**

103322297	20.61	I
103462749	20.61	I
103213642	20.61	I
103136443	20.61	I
102859690	20.61	I
102850850	20.61	I
103404264	20.61	I
103403814	20.61	I
102903247	20.61	I
103341576	20.62	I
103498053	20.7	I
103399046	20.71	I
103223967	20.71	I
103454816	20.71	I
102890670	20.71	I
103386029	20.71	I
103021876	20.71	I
103020504	20.71	I
103020511	20.71	I
103353453	20.73	I
102950228	20.73	I
102988219	20.76	I
102988223	20.76	I
103411796	20.79	I
103425899	20.81	I
102780818	20.81	I
103279178	20.81	I
102652100	20.89	I
102986666	20.91	I
103191629	20.92	I
102980990	20.92	I
103285554	20.92	I
103414309	20.946	I
103498045	21.01	I
103297198	21.01	I
103184369	21.01	I
103320344	21.01	I
103287966	21.01	I
102767999	21.01	I
102654673	21.01	I
103508395	21.02	I

**North Carolina Department of Transportation
Traffic Engineering Accident Analysis System
Strip Analysis Report**

103299466	21.02	I
103385106	21.02	I
103247241	21.02	I
102802431	21.06	I
102963834	21.138	I
103021331	21.138	I
102988231	21.171	I
103011412	21.22	I
103403966	21.31	I
103160118	21.31	I
103280978	21.32	I
102883418	21.32	I
103511870	21.32	I
103061708	21.39	I
102757661	21.42	I
102742270	21.42	I
102971476	21.42	I
102955839	21.42	I
103299445	21.439	I
103459084	21.44	I
103403633	21.48	I
102914255	21.49	I
102949203	21.51	I
102925444	21.51	I
103317205	21.51	I
102897986	21.51	I
102651619	21.51	I
103417563	21.51	I
102855256	21.51	I
102961637	21.51	I
103221163	21.52	I
103284420	21.52	I
103281334	21.52	I
103471375	21.52	I
102862354	21.52	I
103097490	21.52	I
103197829	21.54	I
103120130	21.56	I
102907481	21.58	I
102789352	21.6	I
102674911	21.61	I

**North Carolina Department of Transportation
Traffic Engineering Accident Analysis System
Strip Analysis Report**

102658727	21.61	I
102752573	21.62	I
103455669	21.62	I
103294093	21.62	I
103200811	21.62	I
102917753	21.62	I
103159528	21.62	I
103392407	21.62	I
102897729	21.62	I
102988379	21.72	I
103166263	21.82	I
103470805	21.882	I
103487391	21.91	I
102980991	21.92	I
103062262	21.92	I
103129586	21.92	I
103476236	21.92	I
103493568	21.92	I
103252721	21.92	I
103235582	21.96	I
102880028	22.01	I
103485004	22.02	I
102984984	22.02	I
103196323	22.02	I
102778898	22.02	I
103143869	22.04	I
102680235	22.09	I
103190354	22.12	I
103237059	22.12	I
103338917	22.12	I
103391175	22.22	I
103284422	22.32	I
103046146	22.32	I
102975723	22.32	I
102993756	22.32	I
103126456	22.39	I
103387228	22.41	I
103282168	22.42	I
103234251	22.42	I
102993819	22.42	I
103181104	22.42	I

**North Carolina Department of Transportation
Traffic Engineering Accident Analysis System
Strip Analysis Report**

102997974	22.42	I
102661037	22.42	I
103134173	22.45	I
103294104	22.45	I
102951805	22.45	I
102887814	22.45	I
102856611	22.51	I
102846937	22.51	I
102826428	22.51	I
102813104	22.51	I
102992785	22.52	I
103279138	22.52	I
103043516	22.52	I
102966694	22.52	I
103064102	22.55	I
103404494	22.61	I
103292632	22.61	I
102911207	22.61	I
102897508	22.62	I
103221151	22.62	I
102878472	22.62	I
103114761	22.62	I
103226851	22.62	I
102906199	22.71	I
102898085	22.72	I
103187919	22.82	I
103068183	22.82	I
103464019	22.82	I
103485257	22.82	I
103222281	22.92	I
102762410	22.92	I
103489285	22.92	I
103236626	22.92	I
103272011	22.92	I
103481753	22.967	I
103404226	23.01	I
103156155	23.01	I
102899193	23.038	I
102865865	23.038	I
102659499	23.08	I
103328104	23.11	I

**North Carolina Department of Transportation
Traffic Engineering Accident Analysis System
Strip Analysis Report**

103139620	23.12	I
102815969	23.138	I
103496504	23.17	I
102809406	23.21	I
102943216	23.238	I
103051194	23.32	I
102960184	23.32	I
103428769	23.32	I
102951806	23.338	I
102959761	23.42	I
103123359	23.42	I
102980989	23.42	I
102925940	23.42	I
102918976	23.42	I
102742228	23.42	I
103464546	23.42	I
103032991	23.42	I
103200065	23.438	I
103080273	23.51	I
103499847	23.51	I
103151532	23.52	I
103231790	23.62	I
103174666	23.62	I
103079446	23.62	I
103156892	23.638	I
102898297	23.67	I
103171195	23.67	I
103299391	23.82	I
102851546	23.82	I
102683917	23.82	I
102993345	23.88	I
103000907	23.909	I
102792368	23.92	I
102961546	23.92	I
103031472	23.92	I
103384298	23.92	I
103180406	23.92	I
103046230	23.92	I
103190811	23.92	I
102951043	23.92	I
102851599	23.92	I

**North Carolina Department of Transportation
Traffic Engineering Accident Analysis System
Strip Analysis Report**

102740520	23.92	I
103407371	23.92	I
103231953	23.938	I
103051278	23.938	I
103182380	23.98	I
103028436	24.02	I
102825431	24.02	I
103456417	24.02	I
103415204	24.02	I
102980598	24.02	I
102986976	24.038	I
103497085	24.05	I
103203655	24.061	I
102758575	24.08	I
103310725	24.12	I
103170591	24.12	I
102802559	24.138	I
103057232	24.138	I
103171617	24.138	I
103027650	24.138	I
103018878	24.138	I
102884421	24.138	I
103309938	24.18	I
102773486	24.22	I
103107924	24.22	I
102980594	24.22	I
103486600	24.22	I
102768315	24.25	I
103497278	24.26	I
103508468	24.3	I
103379527	24.32	I
103073837	24.32	I
103176293	24.32	I
103351140	24.32	I
102887830	24.32	I
103030944	24.32	I
103416736	24.32	I
102739886	24.32	I
102710172	24.32	I
102908715	24.338	I
103065862	24.35	I

**North Carolina Department of Transportation
Traffic Engineering Accident Analysis System
Strip Analysis Report**

102768314	24.39	I
102774315	24.398	I
103414360	24.41	I
102752424	24.41	I
103033003	24.42	I
103398312	24.42	I
103243506	24.43	I
102974290	24.52	I
103179144	24.52	I
103157756	24.52	I
102973460	24.52	I
102953660	24.52	I
103168557	24.52	I
102908605	24.52	I
102869533	24.52	I
103304263	24.52	I
102653206	24.53	I
102697099	24.538	I
102701040	24.58	I
102691180	24.62	I
102908662	24.62	I
102897627	24.638	I
102757656	24.638	I
103146479	24.638	I
103024448	24.638	I
102898145	24.638	I
102940880	24.71	I
102738830	24.72	I
103123358	24.738	I
103200073	24.738	I
102728312	24.738	I
102789994	24.788	I
102789991	24.788	I
102657279	24.8	I
102784138	24.81	I
103444671	24.82	I
102932028	24.838	I
102903627	24.838	I
103287472	24.838	I
103104153	24.838	I
102901421	24.838	I

**North Carolina Department of Transportation
Traffic Engineering Accident Analysis System
Strip Analysis Report**

102827298	24.838	I
102765301	24.838	I
102943464	24.888	I
103481712	24.888	I
102920025	24.92	I
103269005	24.92	I
103342915	24.92	I
103191175	24.92	I
103096674	24.92	I
103236610	24.938	I
102886109	24.938	I
102707661	24.938	I
103051218	24.938	I
103051147	24.938	I
102848679	24.938	I
102767704	24.938	I
102770478	25	I
103192456	25.01	I
102768613	25.038	I
102768630	25.038	I
102707344	25.038	I
102677384	25.038	I
103244821	25.038	I
103196287	25.038	I
103353856	25.038	I
103281305	25.038	I
102841745	25.038	I
102780641	25.038	I
102751978	25.038	I
102750934	25.038	I
103509947	25.138	I
102767709	25.138	I
102779644	25.151	I
103005632	25.157	I
103148984	25.22	I
103482374	25.238	I
102834887	25.238	I
102796203	25.238	I
102756359	25.238	I
102733523	25.238	I
102702477	25.238	I

**North Carolina Department of Transportation
Traffic Engineering Accident Analysis System
Strip Analysis Report**

103336680	25.238	I
103279210	25.238	I
102993560	25.238	I
102897214	25.27	I
103374978	25.28	I
103270003	25.32	I
103419924	25.32	I
102920256	25.338	I
102920213	25.338	I
102779616	25.338	I
103471580	25.338	I
103436818	25.338	I
102864193	25.338	I
102838437	25.338	I
102891859	25.338	I
102753761	25.388	I
103191324	25.395	I
103336685	25.438	I
103011601	25.438	I
102679595	25.438	I
102751747	25.47	I
103288122	25.52	I
103095745	25.52	I
102914299	25.52	I
103208440	25.56	I
103190801	25.62	I
103479425	25.638	I
103479415	25.638	I
103479435	25.638	I
102751856	25.638	I
102751751	25.638	I
102875197	25.638	I
102773600	25.738	I
102901155	25.84	I
103496496	25.87	I
102852621	25.92	I
103507715	25.92	I
103370062	25.938	I
102676042	26.1	I
102917767	26.12	I
102961196	26.12	I

**North Carolina Department of Transportation
Traffic Engineering Accident Analysis System
Strip Analysis Report**

103275600	26.138	I
103000588	26.138	I
102929244	26.138	I
102991639	26.138	I
102902166	26.138	I
103284684	26.22	I
103236853	26.22	I
102993149	26.22	I
103501965	26.259	I
102852842	26.259	I
102999724	26.259	I
102809194	26.259	I
102748635	26.27	I
103486743	26.42	I
102952802	26.42	I
102994771	26.454	I
103406570	26.52	I
103410339	26.52	I
102851549	26.62	I
102732537	26.62	I
103419784	26.62	I
102645182	26.659	I
103489396	26.67	I
102738888	26.67	I
103001279	26.759	I
103213393	26.82	I
102751883	26.92	I
102680429	27.02	I
102986559	27.02	I
103024027	27.02	I
103185788	27.02	I
102991490	27.02	I
103254546	27.052	I
103256261	27.12	I
103189004	27.138	I
102964464	27.22	I
102706306	27.22	I
103291052	27.22	I
103208163	27.24	I
103088682	27.259	I
103019583	27.259	I

**North Carolina Department of Transportation
Traffic Engineering Accident Analysis System
Strip Analysis Report**

103481671	27.259	I
103008576	27.259	I
102756952	27.259	I
102696600	27.259	I
102879897	27.28	I
103191238	27.32	I
102964528	27.32	I
103496731	27.32	I
103419777	27.32	I
103255321	27.32	I
103247642	27.32	I
102700919	27.403	I
103112407	27.459	I
102986582	27.459	I
103496491	27.52	I
103254282	27.52	I
103279862	27.552	I
102724420	27.559	I
103294669	27.56	I
103207541	27.62	I
102747225	27.652	I
102897719	27.659	I
103175916	27.759	I
102936321	27.759	I
102964051	27.759	I
103151709	27.859	I
102991605	27.859	I
103204650	27.859	I
102986986	27.859	I
102766983	27.859	I
103019464	27.959	I
103011491	27.959	I
103191545	27.959	I
103275860	28.059	I
103195068	28.059	I
103011474	28.059	I
102930377	28.059	I
103495560	28.059	I
102709693	28.059	I
102980919	28.159	I
102741040	28.159	I

**North Carolina Department of Transportation
Traffic Engineering Accident Analysis System
Strip Analysis Report**

102722432	28.159	I
103275706	28.159	I
103175907	28.159	I
103101188	28.159	I
103061891	28.159	I
102898196	28.159	I
103025967	28.273	I
102980930	28.32	I
103214068	28.359	I
102693397	28.359	I
103488137	28.359	I
102980998	28.359	I
103488211	28.586	I
103387477	29.046	I
103165066	29.186	I
102958671	29.207	I
102715246	29.214	I
102851725	29.226	I
102752304	29.286	I
103446738	29.286	I
102788754	29.286	I
102702419	29.286	I
102658373	29.353	I
103319257	29.386	I
103382395	29.476	I
102931874	29.586	I
103191109	29.586	I
103182009	29.586	I
103327922	29.676	I
102679302	29.686	I
103446752	29.686	I
103443962	29.696	I
103388068	29.786	I
102863908	29.786	I
102769803	29.824	I
103363756	29.867	I
103504879	29.886	I
103137826	29.896	I
102695101	29.986	I
102804230	29.996	I
103169286	30.067	I

**North Carolina Department of Transportation
Traffic Engineering Accident Analysis System
Strip Analysis Report**

103311591	30.096	I
102895661	30.176	I
103439542	30.186	I
103437449	30.186	I
103087764	30.186	I
103503856	30.196	I
102908580	30.21	I
103214926	30.296	I
103487076	30.467	I
103052776	30.467	I
103052575	30.467	I
102901423	30.467	I
102788203	30.467	I
102709818	30.486	I
103437439	30.486	I
103196332	30.496	I
103338865	30.54	I
103416523	30.576	I
103437361	30.586	I
102916838	30.596	I
102941559	30.626	I
102882876	30.64	I
102920329	30.74	I
103403598	30.796	I
103288098	30.967	I
102705479	30.986	I
102783526	31.14	I
103214577	31.167	I
103178059	31.186	I
103342509	31.296	I
102994865	31.386	I
102821369	31.396	I
103329902	31.44	I
103175854	31.44	I
102694231	31.467	I
103490750	31.821	I
102959839	31.832	I
103130245	31.84	I
103012561	31.84	I
102891672	31.859	I
103491013	31.867	I

**North Carolina Department of Transportation
Traffic Engineering Accident Analysis System
Strip Analysis Report**

102847555	31.94	I
103468825	31.967	I
103483074	31.967	I
102996145	32.067	I
103504546	32.067	I
102722835	32.086	I
102753540	32.14	I
102677565	32.167	I
103344026	32.276	I
103012570	32.286	I
102751082	32.286	I
102928095	32.367	I
102808822	32.367	I
103344949	32.367	I
103129978	32.367	I
102720347	32.367	I
103486791	32.367	I
103458599	32.386	I
102914530	32.433	I
103076325	32.476	I
103488200	32.486	I
103219475	32.516	I
102873706	32.536	I
102670250	32.567	I
102911213	32.567	I
102659354	32.586	I
102997017	32.586	I
103343042	32.586	I
102739389	32.586	I
103313567	32.586	I
103179669	32.667	I
103120998	32.667	I
103344007	32.667	I
102695330	32.667	I
103481677	32.686	I
103094201	32.727	I
102742836	32.786	I
103247552	32.927	I
102664964	33.067	I
102996079	33.133	I
102995873	33.133	I

**North Carolina Department of Transportation
Traffic Engineering Accident Analysis System
Strip Analysis Report**

102731707	33.186	I
103504005	33.193	I
102942919	33.193	I
103191204	33.227	I
103298200	33.286	I
103214385	33.293	I
102650709	33.386	I
102871087	33.427	I
103259032	33.486	I
102749717	33.486	I
103253809	33.493	I
103488210	33.586	I
102792360	33.586	I
102696620	33.693	I
102723434	33.786	I
102991507	33.786	I
103344038	33.916	I
103299037	33.986	I
103106992	34.016	I
102709091	34.093	I
102996172	34.186	I
103470190	34.316	I
102683616	34.386	I
102927064	34.467	I
103331847	34.486	I
103255423	34.493	I
103067779	34.516	I
102702791	34.516	I
103507427	34.616	I
102742654	34.686	I
103487809	34.716	I
103191179	34.816	I
102991488	34.816	I
102750366	34.886	I
103359108	34.916	I
103277206	34.916	I
102862174	34.916	I
102785514	34.916	I
103167305	34.916	I
103344027	34.993	I
102697634	34.993	I

**North Carolina Department of Transportation
Traffic Engineering Accident Analysis System
Strip Analysis Report**

103046784	35.016	I
103344008	35.056	I
102981261	35.216	I
103181970	35.216	I
103467845	35.286	I
103438528	35.286	I
102809274	35.293	I
102666316	35.386	I
103319255	35.416	I
103252916	35.493	I
102980619	35.493	I
103151696	35.586	I
102984916	35.586	I
102980639	35.693	I
102892098	35.816	I
102980616	35.893	I
102980615	35.893	I
103238240	35.927	I
102675407	35.927	I
102721151	36.027	I
102776784	36.193	I
102882371	36.327	I
103471637	36.393	I
102746180	36.393	I
103510385	36.627	I
102846943	36.693	I
103434784	36.727	I
102881191	36.727	I
102873386	36.793	I
103400750	36.886	I
103420164	37.186	I
103358944	37.186	I
102780622	37.186	I
103155943	37.193	I
102860747	37.193	I
103125969	37.293	I
103119053	37.293	I
102957265	37.293	I
102791635	37.293	I
103366441	37.393	I
102937163	37.427	I

**North Carolina Department of Transportation
Traffic Engineering Accident Analysis System
Strip Analysis Report**

102926201	37.486	I
103420155	37.493	I
103051133	37.493	I
102653823	37.493	I
103269919	37.593	I
103189842	37.693	I
103437451	37.893	I
103237124	37.993	I
103170318	37.993	I
102993228	38.093	I
103191451	38.093	I
103156857	38.093	I
103050922	38.093	I
102756622	38.093	I
102748673	38.093	I
102695098	38.093	I
102832732	38.149	I
102971405	38.167	I
103334218	38.193	I
103269718	38.193	I
103078504	38.193	I
103504877	38.203	I
102791535	38.203	I
102677930	38.231	I
103229766	38.238	I
103042733	38.288	I
103471075	38.293	I
103420159	38.293	I
102891993	38.293	I
102892042	38.293	I
102669364	38.293	I
103241764	38.293	I
102833360	38.293	I
102822401	38.293	I
102811780	38.393	I
103059268	38.393	I
102652189	38.393	I
102705536	38.486	I
103476067	38.593	I
103454485	38.686	I
102993235	38.693	I

**North Carolina Department of Transportation
Traffic Engineering Accident Analysis System
Strip Analysis Report**

103258735	38.893	I
103069048	38.993	I
102898766	39.093	I
102808755	39.193	I
102656178	39.193	I
102826278	39.264	I
103146175	39.586	I
103408612	39.746	I
102784702	39.893	I
102987438	39.946	I
103303891	39.96	I
103208602	39.96	I
102958425	40.06	I
103143177	40.193	I
103103232	40.193	I
103025809	40.194	I
103346974	40.24	I
103023425	40.26	I
102885107	40.271	I
103226615	40.286	I
103287600	40.36	I
102675485	40.386	I
102832396	40.44	I
102729487	40.46	I
103025094	40.54	I
102963049	40.586	I
102913030	40.64	I
102832199	40.66	I
103491711	40.74	I
103410046	40.746	I
102698762	40.786	I
103138546	40.786	I
103405457	40.836	I
103461858	40.893	I
103234336	40.893	I
102800891	41.06	I
103227817	41.06	I
102666228	41.176	I
102967173	41.193	I
103059257	41.24	I
103179409	41.34	I

**North Carolina Department of Transportation
Traffic Engineering Accident Analysis System
Strip Analysis Report**

103497359	41.44	I
103391145	41.44	I
103292103	41.44	I
102860751	41.54	I
103025073	41.54	I
103059330	41.586	I
102952718	41.64	I
103287277	41.64	I
102868317	41.64	I
102799654	41.64	I
103139202	41.64	I
102912757	41.683	I
103427118	41.74	I
103419851	41.74	I
103194536	41.74	I
102789185	41.759	I
103448937	41.786	I
103200588	41.806	I
102881841	41.84	I
102808831	41.84	I
102875260	41.94	I
103431809	42.086	I
103508019	42.093	I
103485462	42.14	I
103496707	42.24	I
103134867	42.24	I
103311178	42.24	I
103232141	42.286	I
102797502	42.367	I
103287588	42.373	I
103202027	42.397	I
103184223	42.476	I
103263132	42.54	I
103205217	42.54	I
102824778	42.64	I
103151458	42.74	I
102816806	42.74	I
102912921	42.783	I
102754734	42.802	I
103458822	42.94	I
103423626	42.94	I

**North Carolina Department of Transportation
Traffic Engineering Accident Analysis System
Strip Analysis Report**

102938146	42.94	I
102741575	42.94	I
102751080	42.94	I
102677339	43.24	I
102766977	43.24	I
103367276	43.24	I
103375555	43.34	I
102685431	43.34	I
102667757	43.34	I
103050056	43.386	I
102656572	43.44	I
103283476	43.54	I
103312477	43.54	I
102948114	43.64	I
102900780	43.64	I
103169377	43.64	I
103238704	43.71	I
102903198	43.74	I
103087782	43.74	I
103447667	43.74	I
102843904	43.84	I
102699243	43.84	I
103224433	43.84	I
102659227	43.84	I
103097194	43.84	I
103015987	43.96	I
103319642	43.986	I
103348073	43.986	I
103041018	44.14	I
102917186	44.14	I
103043345	44.14	I
103069687	44.193	I
102897667	44.26	I
103200907	44.286	I
102971038	44.305	I
103121267	44.34	I
102770275	44.34	I
102720317	44.34	I
102845940	44.34	I
103448860	44.44	I
103403631	44.536	I

**North Carolina Department of Transportation
Traffic Engineering Accident Analysis System
Strip Analysis Report**

103448766	44.536	I
103444281	44.536	I
102831156	44.536	I
102824683	44.536	I
103316889	44.536	I
103418396	44.536	I
102925920	44.536	I
102935181	44.586	I
103344006	44.64	I
103294545	44.74	I
102881848	44.74	I
102871143	44.76	I
102666303	44.786	I
102684412	44.79	I
102930226	44.84	I
103428092	44.86	I
102869293	44.86	I
102776658	44.886	I
103497221	44.94	I
103002520	44.94	I
102958645	44.94	I
103135072	44.96	I
102834635	45.04	I
102752190	45.09	I
103476995	45.14	I
103384423	45.186	I
103348489	45.186	I
103348027	45.186	I
102768355	45.24	I
102912982	45.286	I
103179580	45.34	I
102766986	45.36	I
103312042	45.386	I
103165263	45.386	I
103510268	45.46	I
103383408	45.46	I
102752950	45.46	I
103236077	45.46	I
102752646	45.54	I
102675477	45.686	I
103239931	45.73	I

**North Carolina Department of Transportation
Traffic Engineering Accident Analysis System
Strip Analysis Report**

103374810	45.84	I
102878491	45.84	I
102937502	45.96	I
103185862	45.986	I
103192690	46.06	I
103500600	46.09	I
103265593	46.14	I
102918535	46.19	I
102927106	46.29	I
103369874	46.34	I
103272096	46.34	I
102747178	46.34	I
103205241	46.54	I
103299957	46.59	I
103179553	46.69	I
103053363	46.84	I
103369751	47	I
103373442	47.81	I
102837471	48.14	I
103506426	48.195	I
103025008	48.2	I
102710289	48.2	I
103185952	48.495	I
102837472	48.54	I
103404414	48.595	I
103417606	48.67	I
103420103	48.7	I
102800545	48.723	I
102888231	48.795	I
103037631	48.81	I
102784469	49.01	I
102952655	49.2	I
103318660	49.21	I
103093999	49.21	I
102877653	49.21	I
102752870	49.21	I
103315737	49.31	I

Fiche Roads

Name	Code
I 1	10000001

**North Carolina Department of Transportation
Traffic Engineering Accident Analysis System
Strip Analysis Report**

Fiche Roads

Name	Code
I 26	10000026
US 74	20000074
US 25	20000025

Strip Road

Name	Code	Begin MP	End MP	Miles	Kilometers
I 1	10000001	18.950	49.310	30.360	48.860

**North Carolina Department of Transportation
Traffic Engineering Accident Analysis System
Fiche, Intersection, and Strip Reports Code Index**

T - Type of Accident Codes

0 = UNKNOWN
1 = RAN OFF ROAD - RIGHT
2 = RAN OFF ROAD - LEFT
3 = RAN OFF ROAD - STRAIGHT
4 = JACKKNIFE
5 = OVERTURN/ROLLOVER
13 = OTHER NON-COLLISION
14 = PEDESTRIAN
15 = PEDALCYCLIST
16 = RR TRAIN, ENGINE
17 = ANIMAL
18 = MOVABLE OBJECT
19 = FIXED OBJECT
20 = PARKED MOTOR VEHICLE
21 = REAR END, SLOW OR STOP
22 = REAR END, TURN
23 = LEFT TURN, SAME ROADWAY
24 = LEFT TURN, DIFFERENT ROADWAYS
25 = RIGHT TURN, SAME ROADWAY
26 = RIGHT TURN, DIFFERENT ROADWAYS
27 = HEAD ON
28 = SIDESWIPE, SAME DIRECTION
29 = SIDESWIPE, OPPOSITE DIRECTION
30 = ANGLE
31 = BACKING UP
32 = OTHER COLLISION WITH VEHICLE

F - Road Feature Codes

0 = NO SPECIAL FEATURE
1 = BRIDGE
2 = BRIDGE APPROACH
3 = UNDERPASS
4 = DRIVEWAY, PUBLIC
5 = DRIVEWAY, PRIVATE
6 = ALLEY INTERSECTION
7 = FOUR-WAY INTERSECTION
8 = T-INTERSECTION
9 = Y-INTERSECTION
10 = TRAFFIC CIRCLE/ROUNDBOUT
11 = FIVE-POINT, OR MORE
12 = RELATED TO INTERSECTION
13 = NON-INTERSECTION MEDIAN CROSSING
14 = END OR BEGINNING - DIVIDED HIGHWAY
15 = OFF RAMP ENTRY
16 = OFF RAMP PROPER
17 = OFF RAMP TERMINAL ON CROSSROAD
18 = MERGE LANE BETWEEN ON AND OFF RAMP
19 = ON RAMP ENTRY
20 = ON RAMP PROPER
21 = ON RAMP TERMINAL ON CROSSROAD
22 = RAILROAD CROSSING
23 = TUNNEL
24 = SHARED-USE PATHS OR TRAILS
25 = OTHER

R - Road Condition Codes

1 = DRY
2 = WET
3 = WATER (STANDING, MOVING)
4 = ICE
5 = SNOW
6 = SLUSH
7 = SAND, MUD, DIRT, GRAVEL
8 = FUEL, OIL
9 = OTHER
10 = UNKNOWN

L - Light Condition Codes

1 = DAYLIGHT
2 = DUSK
3 = DAWN
4 = DARK - LIGHTED ROADWAY
5 = DARK - ROADWAY NOT LIGHTED
6 = DARK - UNKNOWN LIGHTING
7 = OTHER
8 = UNKNOWN

W - Weather Condition Codes

1 = CLEAR
2 = CLOUDY
3 = RAIN
4 = SNOW
5 = FOG, SMOG, SMOKE
6 = SLEET, HAIL, FREEZING RAIN/DRIZZLE
7 = SEVERE CROSSWINDS
8 = BLOWING SAND, DIRT, SNOW
9 = OTHER

S - Accident Severity Codes

K = FATAL
A = A-LEVEL INJURY
B = B-LEVEL INJURY
C = C-LEVEL INJURY
O = PROPERTY DAMAGE ONLY

Ch - Road Character

1 = STRAIGHT, LEVEL
2 = STRAIGHT, HILLCREST
3 = STRAIGHT, GRADE
4 = STRAIGHT, BOTTOM (SAG)
5 = CURVE, LEVEL
6 = CURVE, HILLCREST
7 = CURVE, GRADE
8 = CURVE, BOTTOM (SAG)
9 = OTHER

Op - Traffic Control Operating

1 = YES
2 = NO
3 = UNKNOWN

**North Carolina Department of Transportation
Traffic Engineering Accident Analysis System
Fiche, Intersection, and Strip Reports Code Index**

Veh Mnvr - Vehicle Maneuver Codes

1 = STOPPED IN TRAVEL LANE
2 = PARKED OUT OF TRAVEL LANES
3 = PARKED IN TRAVEL LANES
4 = GOING STRAIGHT AHEAD
5 = CHANGING LANES OR MERGING
6 = PASSING
7 = MAKING RIGHT TURN
8 = MAKING LEFT TURN
9 = MAKING U-TURN
10 = BACKING
11 = SLOWING OR STOPPING
12 = STARTING IN ROADWAY
13 = PARKING
14 = LEAVING PARKED POSITION
15 = AVOIDING OBJECT IN ROAD

Dv - Traffic Control Device

0 = NO CONTROL PRESENT
1 = STOP SIGN
2 = YIELD SIGN
3 = STOP AND GO SIGNAL
4 = FLASHING SIGNAL WITH STOP SIGN
5 = FLASHING SIGNAL WITHOUT STOP SIGN
6 = RR GATE AND FLASHER
7 = RR FLASHER
8 = RR CROSSBUCKS ONLY
9 = HUMAN CONTROL
10 = WARNING SIGN
11 = SCHOOL ZONE SIGNS
12 = FLASHING STOP AND GO SIGNAL
13 = DOUBLE YELLOW LINE, NO PASSING ZONE
14 = OTHER

Alchl/Drugs - Driver Alcohol/Drugs Suspected Status Codes

0 = NO
1 = YES - ALCOHOL, IMPAIRMENT SUSPECTED
2 = YES - ALCOHOL, NO IMPAIRMENT DETECTED
3 = YES - OTHER DRUGS, IMPAIRMENT SUSPECTED
4 = YES - OTHER DRUGS, NO IMPAIRMENT DETECTED
5 = YES - ALCOHOL AND OTHER DRUGS, IMPAIRMENT SUSPECTED
6 = YES - ALCOHOL AND OTHER DRUGS, NO IMPAIRMENT DETECTED
7 = UNKNOWN

Ped Actn - Pedestrian Action Codes

1 = ENTERING OR CROSSING SPECIFIED LOCATION
2 = WALKING, RIDING, RUNNING/JOGGING WITH TRAFFIC
3 = WALKING, RIDING, RUNNING/JOGGING AGAINST TRAFFIC
4 = WORKING
5 = PUSHING VEHICLE
6 = APPROACHING OR LEAVING VEHICLE
7 = PLAYING
8 = STANDING
9 = OTHER

Ci - Roadway Contributing Circumstances

0 = NONE (NO UNUSUAL CONDITIONS)
1 = ROAD SURFACE CONDITION
2 = DEBRIS
3 = RUT, HOLES, BUMPS
4 = WORK ZONE (CONSTRUCTION, MAINTENANCE, UTILITY)
5 = WORN TRAVEL-POLISHED SURFACE
6 = OBSTRUCTION IN ROADWAY
7 = TRAFFIC CONTROL DEVICE INOPERATIVE, NOT VISIBLE OR MISSING
8 = SHOULDERS LOW, SOFT OR HIGH
9 = NO SHOULDERS
10 = NON-HIGHWAY WORK
11 = OTHER
12 = UNKNOWN

**North Carolina Department of Transportation
Traffic Engineering Accident Analysis System
Fiche, Intersection, and Strip Reports Code Index**

Obj Strk - Object Struck Codes

14 = PEDESTRIAN
15 = PEDALCYCLIST
17 = ANIMAL
18 = MOVABLE OBJECT
20 = PARKED MOTOR VEHICLE
33 = TREE
34 = UTILITY POLE
35 = LUMINAIRE POLE NON-BREAKAWAY
36 = LUMINAIRE POLE BREAKAWAY
37 = OFFICIAL HIGHWAY SIGN NON-BREAKAWAY
38 = OFFICIAL HIGHWAY SIGN BREAKAWAY
39 = OVERHEAD SIGN SUPPORT
40 = COMMERCIAL SIGN
41 = GUARDRAIL END ON SHOULDER
42 = GUARDRAIL FACE ON SHOULDER
43 = GUARDRAIL END IN MEDIAN
44 = GUARDRAIL FACE IN MEDIAN
45 = SHOULDER BARRIER END
46 = SHOULDER BARRIER FACE
47 = MEDIAN BARRIER END
48 = MEDIAN BARRIER FACE
49 = BRIDGE RAIL END
50 = BRIDGE RAIL FACE
51 = OVERHEAD PART UNDERPASS
52 = PIER ON SHOULDER OF UNDERPASS
53 = PIER IN MEDIAN OF UNDERPASS
54 = ABUTMENT OF UNDERPASS
55 = TRAFFIC ISLAND CURB OR MEDIAN
56 = CATCH BASIN OR CULVERT ON SHOULDER
57 = CATCH BASIN OR CULVERT ON MEDIAN
58 = DITCH
59 = EMBANKMENT
60 = MAILBOX
61 = FENCE OR FENCE POST
62 = CONSTRUCTION BARRIER
63 = CRASH CUSHION
64 = OTHER FIXED OBJECT

Unit # - Vehicle Style Codes

1 = PASSENGER CAR
2 = PICKUP
3 = LIGHT TRUCK (MINI-VAN, PANEL)
4 = SPORT UTILITY
5 = VAN
6 = COMMERCIAL BUS
7 = SCHOOL BUS
8 = ACTIVITY BUS
9 = OTHER BUS
10 = SINGLE UNIT TRUCK (2-AXLE, 6-TIRE)
11 = SINGLE UNIT TRUCK (3 OR MORE AXLES)
12 = TRUCK/TRAILER
13 = TRUCK/TRACTOR
14 = TRACTOR/SEMI-TRAILER
15 = TRACTOR/DOULBES
16 = UNKNOWN HEAVY TRUCK
17 = TAXICAB
18 = FARM EQUIPMENT
19 = FARM TRACTOR
20 = MOTORCYCLE
21 = MOPED
22 = MOTOR SCOOTER OR MOTOR BIKE
23 = PEDALCYCLE
24 = PEDESTRIAN
25 = MOTOR HOME/RECREATIONAL VEHICLE
26 = OTHER
27 = ALL TERRAIN VEHICLE (ATV)
28 = FIRETRUCK
29 = EMS VEHICLE, AMBULANCE, RESCUE SQUAD
30 = MILITARY
31 = POLICE
32 = UNKNOWN

Appendix I – Failure Year Analysis

I-26 Mainline Segment Capacity Check

Basic Freeway Segment	Name	X-Line	Type	No-Build LOS						Build 6 Lane LOS						Build 8 Lane LOS								
				2011	2015	2020	2025	2030	2035	2040	2011	2015	2020	2025	2030	2035	2040	2011	2015	2020	2025	2030	2035	2040
I-40 to NC 191	B1	I-26	Basic	F	F	F	F	F	F	F	D	E	E	E	E	E	F	C	C	D	D	D	D	D
				64.0	67.6	72.5	78.1	84.6	92.3	101.4	34.1	35.5	37.5	39.6	41.9	44.5	47.3	24.2	25.1	26.2	27.4	28.7	30.0	31.4
NC 146 to NC 280	B2	I-26	Basic	E	F	F	F	F	F	F	D	D	D	D	E	E	E	C	C	C	C	D	D	D
				43.9	46.1	49.2	52.6	56.6	61.1	66.3	28.5	29.9	31.9	34.1	36.5	39.1	42.2	21.3	22.3	23.6	25.0	26.4	28.0	29.6
NC 280 to US 25	B3	I-26	Basic	D	D	E	E	F	F	F	C	C	C	D	D	D	E	B	B	C	C	C	C	D
				30.0	32.6	36.3	40.7	46.1	52.8	61.4	21.2	22.8	25.0	27.5	30.2	33.4	37.1	16.4	17.8	19.5	21.2	23.0	24.9	27
US 25 to US 64 (Balfour Pkwy in 2040)	B4	I-26	Basic	C	D	D	D	E	E	E	B	C	C	C	D	D	D	B	B	B	C	C	C	C
				25.4	27.3	29.9	32.8	36.2	40.0	44.6	17.7	19.3	21.3	23.6	26.0	28.8	31.9	13.6	14.9	16.5	18.2	19.9	21.7	23.6
US 64 to Upward Road	B5	I-26	Basic	C	C	D	D	D	E	E	B	B	C	C	C	D	D	B	B	B	B	B	C	C
				23.2	25.2	27.9	30.9	34.4	38.5	43.3	15.4	16.9	18.8	20.8	23.0	25.4	28	11.7	12.9	14.3	15.8	17.3	18.8	20.4

Basic Freeway Segment	Name	X-Line	Type	No-Build Volume						Build 6 Lane Volume						Build 8 Lane Volume								
				2011	2015	2020	2025	2030	2035	2040	2011	2015	2020	2025	2030	2035	2040	2011	2015	2020	2025	2030	2035	2040
I-40 to NC 191	B1	I-26	Basic	4,423	4,493	4,579	4,666	4,753	4,840	4,927	5,020	5,148	5,308	5,468	5,629	5,789	5,949	5,165	5,327	5,531	5,734	5,937	6,140	6,343
NC 146 to NC 280	B2	I-26	Basic	3,888	3,977	4,088	4,198	4,309	4,420	4,531	4,496	4,665	4,877	5,088	5,300	5,511	5,723	4,645	4,856	5,120	5,383	5,647	5,910	6,174
NC 280 to US 25	B3	I-26	Basic	3,074	3,252	3,475	3,698	3,920	4,143	4,366	3,415	3,672	3,992	4,313	4,634	4,954	5,275	3,516	3,813	4,183	4,554	4,925	5,295	5,666
US 25 to US 64 (Balfour Pkwy in 2040)	B4	I-26	Basic	2,810	2,967	3,162	3,358	3,554	3,749	3,945	3,073	3,331	3,654	3,977	4,299	4,622	4,945	3,151	3,449	3,821	4,193	4,565	4,937	5,309
US 64 to Upward Road	B5	I-26	Basic	2,619	2,795	3,015	3,235	3,454	3,674	3,894	2,670	2,927	3,249	3,571	3,893	4,214	4,536	2,699	2,971	3,311	3,651	3,992	4,332	4,672

* HCS basic freeway segment volume based on highest AM/PM EB/WB peak hour breakout volume between adjacent interchanges to present worst case LOS/delay.

Interpolating Intermediate Traffic Volumes

Location : I-26
Description : No-Build I-40 to NC 191

Input Beginning Year = Beginning Avg Delay =
 Input Ending Year = Ending Avg Delay =

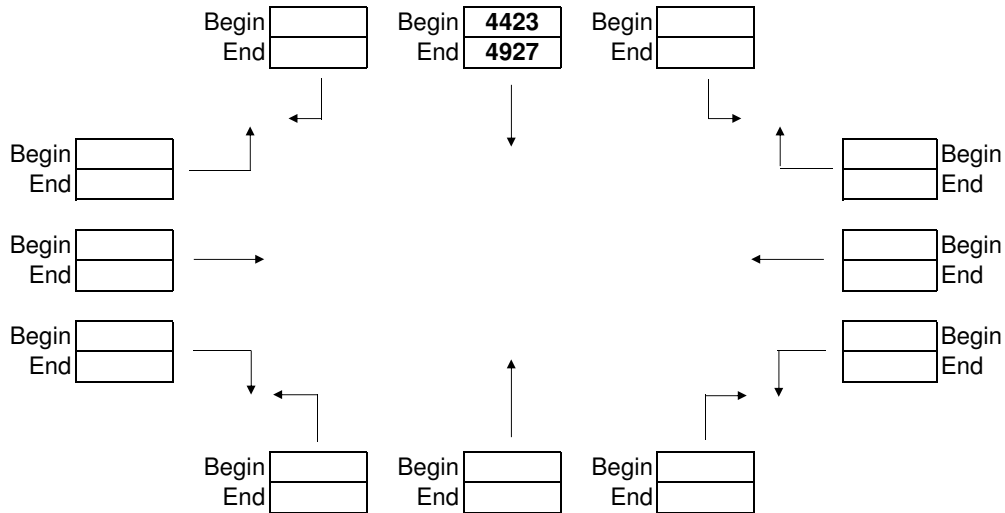

Year	Avg Delay in secs.	EB LT Volume	EB TH Volume	EB RT Volume	WB LT Volume	WB TH Volume	WB RT Volume	NB LT Volume	NB TH Volume	NB RT Volume	SB LT Volume	SB TH Volume	SB RT Volume
2011	0	0	0	0	0	0	0	0	0	0	0	4423	0
2012	0.0	0	0	0	0	0	0	0	0	0	0	4440	0
2013	0.0	0	0	0	0	0	0	0	0	0	0	4458	0
2014	0.0	0	0	0	0	0	0	0	0	0	0	4475	0
2015	0.0	0	0	0	0	0	0	0	0	0	0	4493	0
2016	0.0	0	0	0	0	0	0	0	0	0	0	4510	0
2017	0.0	0	0	0	0	0	0	0	0	0	0	4527	0
2018	0.0	0	0	0	0	0	0	0	0	0	0	4545	0
2019	0.0	0	0	0	0	0	0	0	0	0	0	4562	0
2020	0.0	0	0	0	0	0	0	0	0	0	0	4579	0
2021	0.0	0	0	0	0	0	0	0	0	0	0	4597	0
2022	0.0	0	0	0	0	0	0	0	0	0	0	4614	0
2023	0.0	0	0	0	0	0	0	0	0	0	0	4632	0
2024	0.0	0	0	0	0	0	0	0	0	0	0	4649	0
2025	0.0	0	0	0	0	0	0	0	0	0	0	4666	0
2026	0.0	0	0	0	0	0	0	0	0	0	0	4684	0
2027	0.0	0	0	0	0	0	0	0	0	0	0	4701	0
2028	0.0	0	0	0	0	0	0	0	0	0	0	4718	0
2029	0.0	0	0	0	0	0	0	0	0	0	0	4736	0
2030	0.0	0	0	0	0	0	0	0	0	0	0	4753	0
2031	0.0	0	0	0	0	0	0	0	0	0	0	4771	0
2032	0.0	0	0	0	0	0	0	0	0	0	0	4788	0
2033	0.0	0	0	0	0	0	0	0	0	0	0	4805	0
2034	0.0	0	0	0	0	0	0	0	0	0	0	4823	0
2035	0.0	0	0	0	0	0	0	0	0	0	0	4840	0
2036	0.0	0	0	0	0	0	0	0	0	0	0	4857	0
2037	0.0	0	0	0	0	0	0	0	0	0	0	4875	0
2038	0.0	0	0	0	0	0	0	0	0	0	0	4892	0
2039	0.0	0	0	0	0	0	0	0	0	0	0	4910	0

Note : Average Delay in seconds is not a straight line interpolation and should only be used as a reference.

Interpolating Intermediate Traffic Volumes

Location : I-26
Description : No-Build NC 146 to NC 280

Input Beginning Year = Beginning Avg Delay =
 Input Ending Year = Ending Avg Delay =

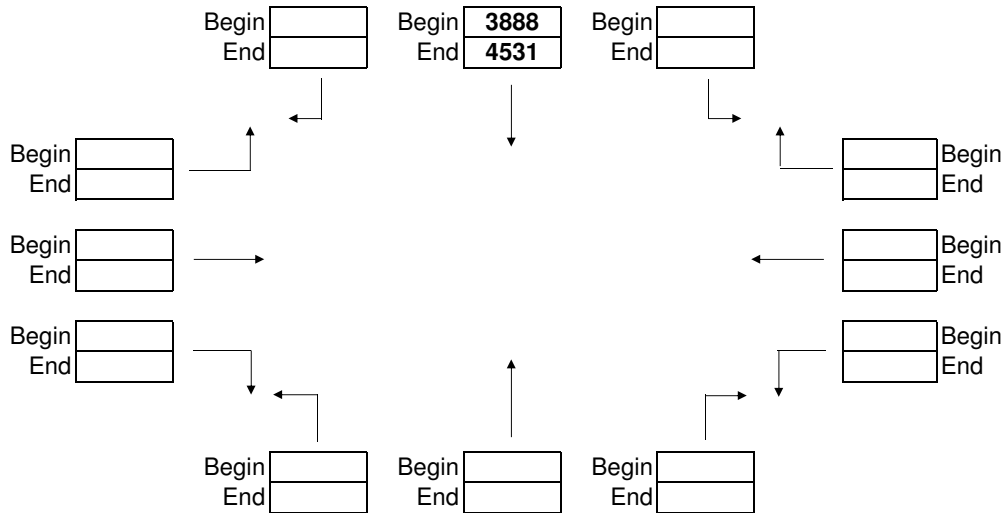

Year	Avg Delay in secs.	EB LT Volume	EB TH Volume	EB RT Volume	WB LT Volume	WB TH Volume	WB RT Volume	NB LT Volume	NB TH Volume	NB RT Volume	SB LT Volume	SB TH Volume	SB RT Volume
2011	0	0	0	0	0	0	0	0	0	0	0	3888	0
2012	0.0	0	0	0	0	0	0	0	0	0	0	3910	0
2013	0.0	0	0	0	0	0	0	0	0	0	0	3932	0
2014	0.0	0	0	0	0	0	0	0	0	0	0	3955	0
2015	0.0	0	0	0	0	0	0	0	0	0	0	3977	0
2016	0.0	0	0	0	0	0	0	0	0	0	0	3999	0
2017	0.0	0	0	0	0	0	0	0	0	0	0	4021	0
2018	0.0	0	0	0	0	0	0	0	0	0	0	4043	0
2019	0.0	0	0	0	0	0	0	0	0	0	0	4065	0
2020	0.0	0	0	0	0	0	0	0	0	0	0	4088	0
2021	0.0	0	0	0	0	0	0	0	0	0	0	4110	0
2022	0.0	0	0	0	0	0	0	0	0	0	0	4132	0
2023	0.0	0	0	0	0	0	0	0	0	0	0	4154	0
2024	0.0	0	0	0	0	0	0	0	0	0	0	4176	0
2025	0.0	0	0	0	0	0	0	0	0	0	0	4198	0
2026	0.0	0	0	0	0	0	0	0	0	0	0	4221	0
2027	0.0	0	0	0	0	0	0	0	0	0	0	4243	0
2028	0.0	0	0	0	0	0	0	0	0	0	0	4265	0
2029	0.0	0	0	0	0	0	0	0	0	0	0	4287	0
2030	0.0	0	0	0	0	0	0	0	0	0	0	4309	0
2031	0.0	0	0	0	0	0	0	0	0	0	0	4331	0
2032	0.0	0	0	0	0	0	0	0	0	0	0	4354	0
2033	0.0	0	0	0	0	0	0	0	0	0	0	4376	0
2034	0.0	0	0	0	0	0	0	0	0	0	0	4398	0
2035	0.0	0	0	0	0	0	0	0	0	0	0	4420	0
2036	0.0	0	0	0	0	0	0	0	0	0	0	4442	0
2037	0.0	0	0	0	0	0	0	0	0	0	0	4464	0
2038	0.0	0	0	0	0	0	0	0	0	0	0	4487	0
2039	0.0	0	0	0	0	0	0	0	0	0	0	4509	0

Note : Average Delay in seconds is not a straight line interpolation and should only be used as a reference.

Interpolating Intermediate Traffic Volumes

Location : I-26
Description : No-Build NC 280 to US 25

Input Beginning Year = Beginning Avg Delay =
 Input Ending Year = Ending Avg Delay =

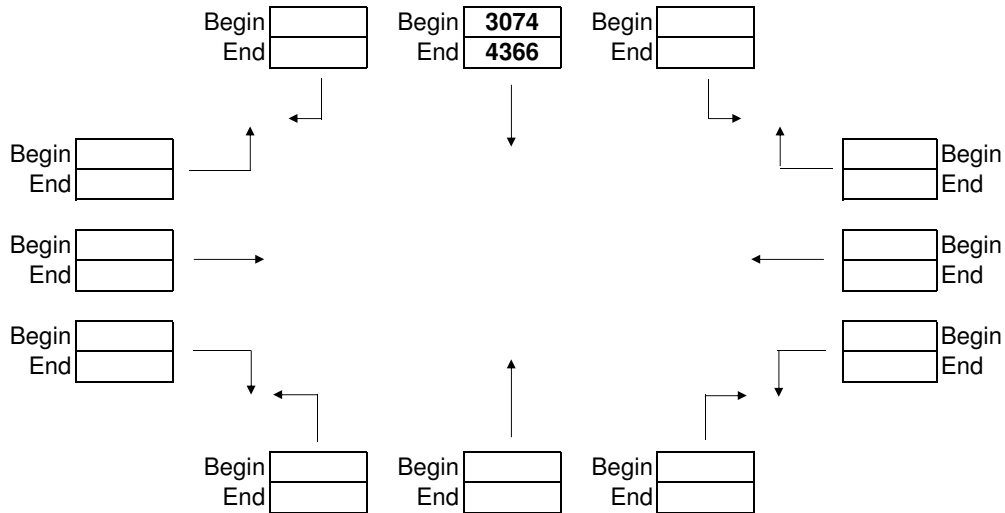

Year	Avg Delay in secs.	EB LT Volume	EB TH Volume	EB RT Volume	WB LT Volume	WB TH Volume	WB RT Volume	NB LT Volume	NB TH Volume	NB RT Volume	SB LT Volume	SB TH Volume	SB RT Volume
2011	0	0	0	0	0	0	0	0	0	0	0	3074	0
2012	0.0	0	0	0	0	0	0	0	0	0	0	3119	0
2013	0.0	0	0	0	0	0	0	0	0	0	0	3163	0
2014	0.0	0	0	0	0	0	0	0	0	0	0	3208	0
2015	0.0	0	0	0	0	0	0	0	0	0	0	3252	0
2016	0.0	0	0	0	0	0	0	0	0	0	0	3297	0
2017	0.0	0	0	0	0	0	0	0	0	0	0	3341	0
2018	0.0	0	0	0	0	0	0	0	0	0	0	3386	0
2019	0.0	0	0	0	0	0	0	0	0	0	0	3430	0
2020	0.0	0	0	0	0	0	0	0	0	0	0	3475	0
2021	0.0	0	0	0	0	0	0	0	0	0	0	3520	0
2022	0.0	0	0	0	0	0	0	0	0	0	0	3564	0
2023	0.0	0	0	0	0	0	0	0	0	0	0	3609	0
2024	0.0	0	0	0	0	0	0	0	0	0	0	3653	0
2025	0.0	0	0	0	0	0	0	0	0	0	0	3698	0
2026	0.0	0	0	0	0	0	0	0	0	0	0	3742	0
2027	0.0	0	0	0	0	0	0	0	0	0	0	3787	0
2028	0.0	0	0	0	0	0	0	0	0	0	0	3831	0
2029	0.0	0	0	0	0	0	0	0	0	0	0	3876	0
2030	0.0	0	0	0	0	0	0	0	0	0	0	3920	0
2031	0.0	0	0	0	0	0	0	0	0	0	0	3965	0
2032	0.0	0	0	0	0	0	0	0	0	0	0	4010	0
2033	0.0	0	0	0	0	0	0	0	0	0	0	4054	0
2034	0.0	0	0	0	0	0	0	0	0	0	0	4099	0
2035	0.0	0	0	0	0	0	0	0	0	0	0	4143	0
2036	0.0	0	0	0	0	0	0	0	0	0	0	4188	0
2037	0.0	0	0	0	0	0	0	0	0	0	0	4232	0
2038	0.0	0	0	0	0	0	0	0	0	0	0	4277	0
2039	0.0	0	0	0	0	0	0	0	0	0	0	4321	0

Note : Average Delay in seconds is not a straight line interpolation and should only be used as a reference.

Interpolating Intermediate Traffic Volumes

Location : I-26
Description : No-Build US 25 to US 64

Input Beginning Year = Beginning Avg Delay =
 Input Ending Year = Ending Avg Delay =

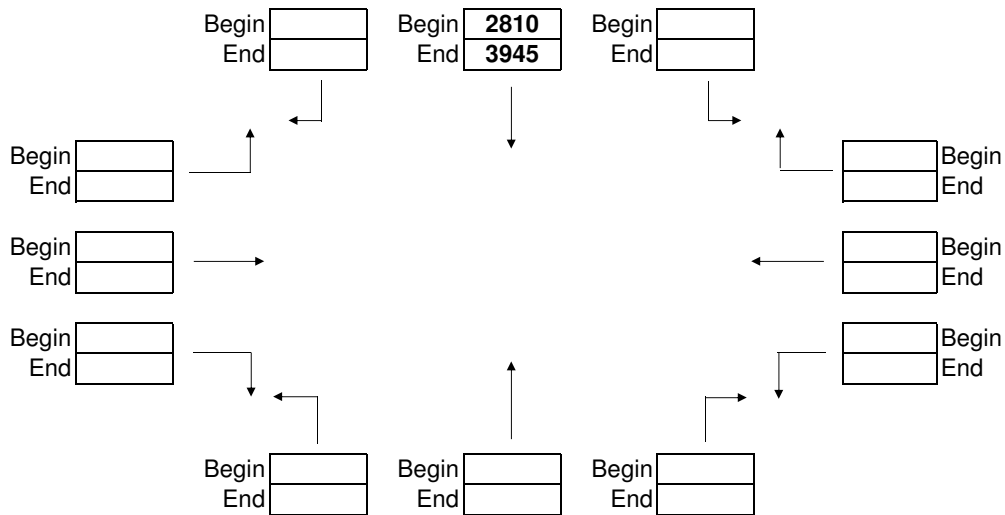

Year	Avg Delay in secs.	EB LT Volume	EB TH Volume	EB RT Volume	WB LT Volume	WB TH Volume	WB RT Volume	NB LT Volume	NB TH Volume	NB RT Volume	SB LT Volume	SB TH Volume	SB RT Volume
2011	0	0	0	0	0	0	0	0	0	0	0	2810	0
2012	0.0	0	0	0	0	0	0	0	0	0	0	2849	0
2013	0.0	0	0	0	0	0	0	0	0	0	0	2888	0
2014	0.0	0	0	0	0	0	0	0	0	0	0	2927	0
2015	0.0	0	0	0	0	0	0	0	0	0	0	2967	0
2016	0.0	0	0	0	0	0	0	0	0	0	0	3006	0
2017	0.0	0	0	0	0	0	0	0	0	0	0	3045	0
2018	0.0	0	0	0	0	0	0	0	0	0	0	3084	0
2019	0.0	0	0	0	0	0	0	0	0	0	0	3123	0
2020	0.0	0	0	0	0	0	0	0	0	0	0	3162	0
2021	0.0	0	0	0	0	0	0	0	0	0	0	3201	0
2022	0.0	0	0	0	0	0	0	0	0	0	0	3241	0
2023	0.0	0	0	0	0	0	0	0	0	0	0	3280	0
2024	0.0	0	0	0	0	0	0	0	0	0	0	3319	0
2025	0.0	0	0	0	0	0	0	0	0	0	0	3358	0
2026	0.0	0	0	0	0	0	0	0	0	0	0	3397	0
2027	0.0	0	0	0	0	0	0	0	0	0	0	3436	0
2028	0.0	0	0	0	0	0	0	0	0	0	0	3475	0
2029	0.0	0	0	0	0	0	0	0	0	0	0	3514	0
2030	0.0	0	0	0	0	0	0	0	0	0	0	3554	0
2031	0.0	0	0	0	0	0	0	0	0	0	0	3593	0
2032	0.0	0	0	0	0	0	0	0	0	0	0	3632	0
2033	0.0	0	0	0	0	0	0	0	0	0	0	3671	0
2034	0.0	0	0	0	0	0	0	0	0	0	0	3710	0
2035	0.0	0	0	0	0	0	0	0	0	0	0	3749	0
2036	0.0	0	0	0	0	0	0	0	0	0	0	3788	0
2037	0.0	0	0	0	0	0	0	0	0	0	0	3828	0
2038	0.0	0	0	0	0	0	0	0	0	0	0	3867	0
2039	0.0	0	0	0	0	0	0	0	0	0	0	3906	0

Note : Average Delay in seconds is not a straight line interpolation and should only be used as a reference.

Interpolating Intermediate Traffic Volumes

Location : I-26
Description : No-Build US 64 to Upward Rd

Input Beginning Year = Beginning Avg Delay =
 Input Ending Year = Ending Avg Delay =

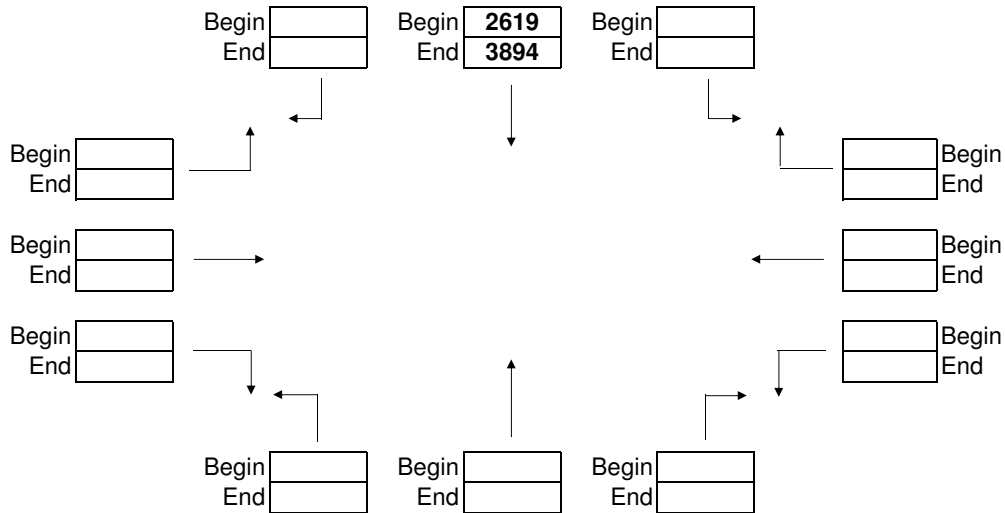

Year	Avg Delay in secs.	EB LT Volume	EB TH Volume	EB RT Volume	WB LT Volume	WB TH Volume	WB RT Volume	NB LT Volume	NB TH Volume	NB RT Volume	SB LT Volume	SB TH Volume	SB RT Volume
2011	0	0	0	0	0	0	0	0	0	0	0	2619	0
2012	0.0	0	0	0	0	0	0	0	0	0	0	2663	0
2013	0.0	0	0	0	0	0	0	0	0	0	0	2707	0
2014	0.0	0	0	0	0	0	0	0	0	0	0	2751	0
2015	0.0	0	0	0	0	0	0	0	0	0	0	2795	0
2016	0.0	0	0	0	0	0	0	0	0	0	0	2839	0
2017	0.0	0	0	0	0	0	0	0	0	0	0	2883	0
2018	0.0	0	0	0	0	0	0	0	0	0	0	2927	0
2019	0.0	0	0	0	0	0	0	0	0	0	0	2971	0
2020	0.0	0	0	0	0	0	0	0	0	0	0	3015	0
2021	0.0	0	0	0	0	0	0	0	0	0	0	3059	0
2022	0.0	0	0	0	0	0	0	0	0	0	0	3103	0
2023	0.0	0	0	0	0	0	0	0	0	0	0	3147	0
2024	0.0	0	0	0	0	0	0	0	0	0	0	3191	0
2025	0.0	0	0	0	0	0	0	0	0	0	0	3235	0
2026	0.0	0	0	0	0	0	0	0	0	0	0	3278	0
2027	0.0	0	0	0	0	0	0	0	0	0	0	3322	0
2028	0.0	0	0	0	0	0	0	0	0	0	0	3366	0
2029	0.0	0	0	0	0	0	0	0	0	0	0	3410	0
2030	0.0	0	0	0	0	0	0	0	0	0	0	3454	0
2031	0.0	0	0	0	0	0	0	0	0	0	0	3498	0
2032	0.0	0	0	0	0	0	0	0	0	0	0	3542	0
2033	0.0	0	0	0	0	0	0	0	0	0	0	3586	0
2034	0.0	0	0	0	0	0	0	0	0	0	0	3630	0
2035	0.0	0	0	0	0	0	0	0	0	0	0	3674	0
2036	0.0	0	0	0	0	0	0	0	0	0	0	3718	0
2037	0.0	0	0	0	0	0	0	0	0	0	0	3762	0
2038	0.0	0	0	0	0	0	0	0	0	0	0	3806	0
2039	0.0	0	0	0	0	0	0	0	0	0	0	3850	0

Note : Average Delay in seconds is not a straight line interpolation and should only be used as a reference.

Interpolating Intermediate Traffic Volumes

Location : I-26
Description : Build 6 Lane I-40 to NC 191

Input Beginning Year = Beginning Avg Delay =
 Input Ending Year = Ending Avg Delay =

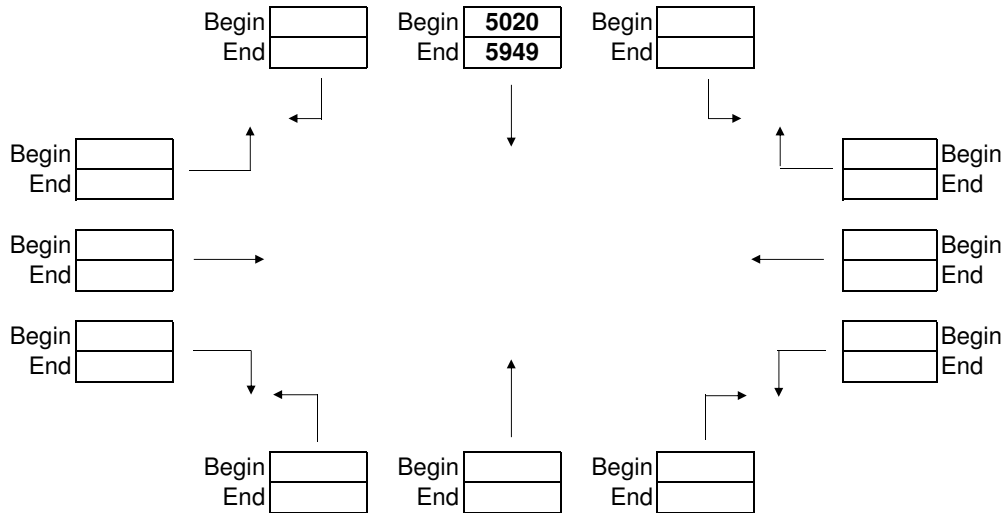

Year	Avg Delay in secs.	EB LT Volume	EB TH Volume	EB RT Volume	WB LT Volume	WB TH Volume	WB RT Volume	NB LT Volume	NB TH Volume	NB RT Volume	SB LT Volume	SB TH Volume	SB RT Volume
2011	0	0	0	0	0	0	0	0	0	0	0	5020	0
2012	0.0	0	0	0	0	0	0	0	0	0	0	5052	0
2013	0.0	0	0	0	0	0	0	0	0	0	0	5084	0
2014	0.0	0	0	0	0	0	0	0	0	0	0	5116	0
2015	0.0	0	0	0	0	0	0	0	0	0	0	5148	0
2016	0.0	0	0	0	0	0	0	0	0	0	0	5180	0
2017	0.0	0	0	0	0	0	0	0	0	0	0	5212	0
2018	0.0	0	0	0	0	0	0	0	0	0	0	5244	0
2019	0.0	0	0	0	0	0	0	0	0	0	0	5276	0
2020	0.0	0	0	0	0	0	0	0	0	0	0	5308	0
2021	0.0	0	0	0	0	0	0	0	0	0	0	5340	0
2022	0.0	0	0	0	0	0	0	0	0	0	0	5372	0
2023	0.0	0	0	0	0	0	0	0	0	0	0	5404	0
2024	0.0	0	0	0	0	0	0	0	0	0	0	5436	0
2025	0.0	0	0	0	0	0	0	0	0	0	0	5468	0
2026	0.0	0	0	0	0	0	0	0	0	0	0	5501	0
2027	0.0	0	0	0	0	0	0	0	0	0	0	5533	0
2028	0.0	0	0	0	0	0	0	0	0	0	0	5565	0
2029	0.0	0	0	0	0	0	0	0	0	0	0	5597	0
2030	0.0	0	0	0	0	0	0	0	0	0	0	5629	0
2031	0.0	0	0	0	0	0	0	0	0	0	0	5661	0
2032	0.0	0	0	0	0	0	0	0	0	0	0	5693	0
2033	0.0	0	0	0	0	0	0	0	0	0	0	5725	0
2034	0.0	0	0	0	0	0	0	0	0	0	0	5757	0
2035	0.0	0	0	0	0	0	0	0	0	0	0	5789	0
2036	0.0	0	0	0	0	0	0	0	0	0	0	5821	0
2037	0.0	0	0	0	0	0	0	0	0	0	0	5853	0
2038	0.0	0	0	0	0	0	0	0	0	0	0	5885	0
2039	0.0	0	0	0	0	0	0	0	0	0	0	5917	0

Note : Average Delay in seconds is not a straight line interpolation and should only be used as a reference.

Interpolating Intermediate Traffic Volumes

Location : I-26
Description : Build 6 Lane NC 146 to NC 280

Input Beginning Year = Beginning Avg Delay =
Input Ending Year = Ending Avg Delay =

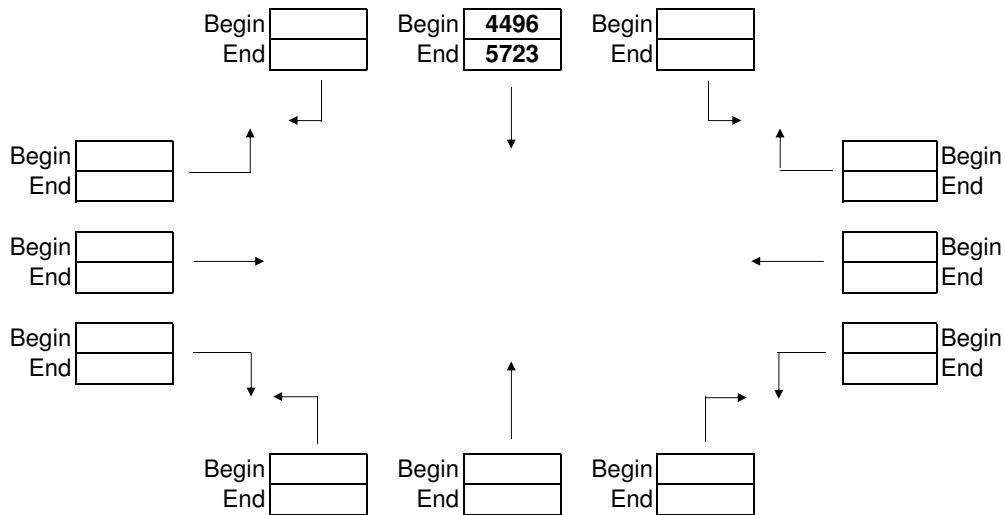

Year	Avg Delay in secs.	EB LT Volume	EB TH Volume	EB RT Volume	WB LT Volume	WB TH Volume	WB RT Volume	NB LT Volume	NB TH Volume	NB RT Volume	SB LT Volume	SB TH Volume	SB RT Volume
2011	0	0	0	0	0	0	0	0	0	0	0	4496	0
2012	0.0	0	0	0	0	0	0	0	0	0	0	4538	0
2013	0.0	0	0	0	0	0	0	0	0	0	0	4581	0
2014	0.0	0	0	0	0	0	0	0	0	0	0	4623	0
2015	0.0	0	0	0	0	0	0	0	0	0	0	4665	0
2016	0.0	0	0	0	0	0	0	0	0	0	0	4708	0
2017	0.0	0	0	0	0	0	0	0	0	0	0	4750	0
2018	0.0	0	0	0	0	0	0	0	0	0	0	4792	0
2019	0.0	0	0	0	0	0	0	0	0	0	0	4834	0
2020	0.0	0	0	0	0	0	0	0	0	0	0	4877	0
2021	0.0	0	0	0	0	0	0	0	0	0	0	4919	0
2022	0.0	0	0	0	0	0	0	0	0	0	0	4961	0
2023	0.0	0	0	0	0	0	0	0	0	0	0	5004	0
2024	0.0	0	0	0	0	0	0	0	0	0	0	5046	0
2025	0.0	0	0	0	0	0	0	0	0	0	0	5088	0
2026	0.0	0	0	0	0	0	0	0	0	0	0	5131	0
2027	0.0	0	0	0	0	0	0	0	0	0	0	5173	0
2028	0.0	0	0	0	0	0	0	0	0	0	0	5215	0
2029	0.0	0	0	0	0	0	0	0	0	0	0	5258	0
2030	0.0	0	0	0	0	0	0	0	0	0	0	5300	0
2031	0.0	0	0	0	0	0	0	0	0	0	0	5342	0
2032	0.0	0	0	0	0	0	0	0	0	0	0	5385	0
2033	0.0	0	0	0	0	0	0	0	0	0	0	5427	0
2034	0.0	0	0	0	0	0	0	0	0	0	0	5469	0
2035	0.0	0	0	0	0	0	0	0	0	0	0	5511	0
2036	0.0	0	0	0	0	0	0	0	0	0	0	5554	0
2037	0.0	0	0	0	0	0	0	0	0	0	0	5596	0
2038	0.0	0	0	0	0	0	0	0	0	0	0	5638	0
2039	0.0	0	0	0	0	0	0	0	0	0	0	5681	0

Note : Average Delay in seconds is not a straight line interpolation and should only be used as a reference.

Interpolating Intermediate Traffic Volumes

Location : I-26
Description : Build 6 Lane NC 280 to US 25

Input Beginning Year = Beginning Avg Delay =
Input Ending Year = Ending Avg Delay =

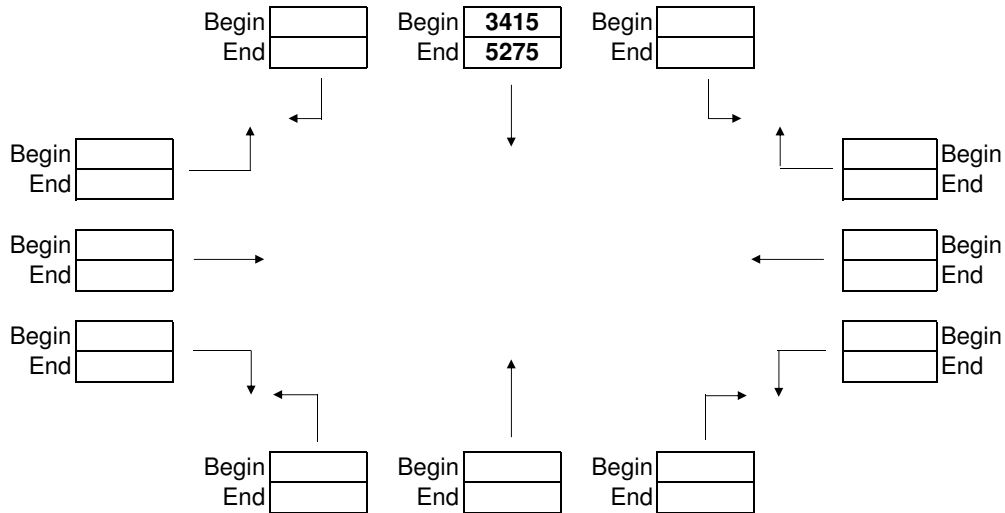

Year	Avg Delay in secs.	EB LT Volume	EB TH Volume	EB RT Volume	WB LT Volume	WB TH Volume	WB RT Volume	NB LT Volume	NB TH Volume	NB RT Volume	SB LT Volume	SB TH Volume	SB RT Volume
2011	0	0	0	0	0	0	0	0	0	0	0	3415	0
2012	0.0	0	0	0	0	0	0	0	0	0	0	3479	0
2013	0.0	0	0	0	0	0	0	0	0	0	0	3543	0
2014	0.0	0	0	0	0	0	0	0	0	0	0	3607	0
2015	0.0	0	0	0	0	0	0	0	0	0	0	3672	0
2016	0.0	0	0	0	0	0	0	0	0	0	0	3736	0
2017	0.0	0	0	0	0	0	0	0	0	0	0	3800	0
2018	0.0	0	0	0	0	0	0	0	0	0	0	3864	0
2019	0.0	0	0	0	0	0	0	0	0	0	0	3928	0
2020	0.0	0	0	0	0	0	0	0	0	0	0	3992	0
2021	0.0	0	0	0	0	0	0	0	0	0	0	4056	0
2022	0.0	0	0	0	0	0	0	0	0	0	0	4121	0
2023	0.0	0	0	0	0	0	0	0	0	0	0	4185	0
2024	0.0	0	0	0	0	0	0	0	0	0	0	4249	0
2025	0.0	0	0	0	0	0	0	0	0	0	0	4313	0
2026	0.0	0	0	0	0	0	0	0	0	0	0	4377	0
2027	0.0	0	0	0	0	0	0	0	0	0	0	4441	0
2028	0.0	0	0	0	0	0	0	0	0	0	0	4505	0
2029	0.0	0	0	0	0	0	0	0	0	0	0	4569	0
2030	0.0	0	0	0	0	0	0	0	0	0	0	4634	0
2031	0.0	0	0	0	0	0	0	0	0	0	0	4698	0
2032	0.0	0	0	0	0	0	0	0	0	0	0	4762	0
2033	0.0	0	0	0	0	0	0	0	0	0	0	4826	0
2034	0.0	0	0	0	0	0	0	0	0	0	0	4890	0
2035	0.0	0	0	0	0	0	0	0	0	0	0	4954	0
2036	0.0	0	0	0	0	0	0	0	0	0	0	5018	0
2037	0.0	0	0	0	0	0	0	0	0	0	0	5083	0
2038	0.0	0	0	0	0	0	0	0	0	0	0	5147	0
2039	0.0	0	0	0	0	0	0	0	0	0	0	5211	0

Note : Average Delay in seconds is not a straight line interpolation and should only be used as a reference.

Interpolating Intermediate Traffic Volumes

Location : I-26
Description : Build 6 Lane US 25 to US 64

Input Beginning Year = Beginning Avg Delay =
 Input Ending Year = Ending Avg Delay =

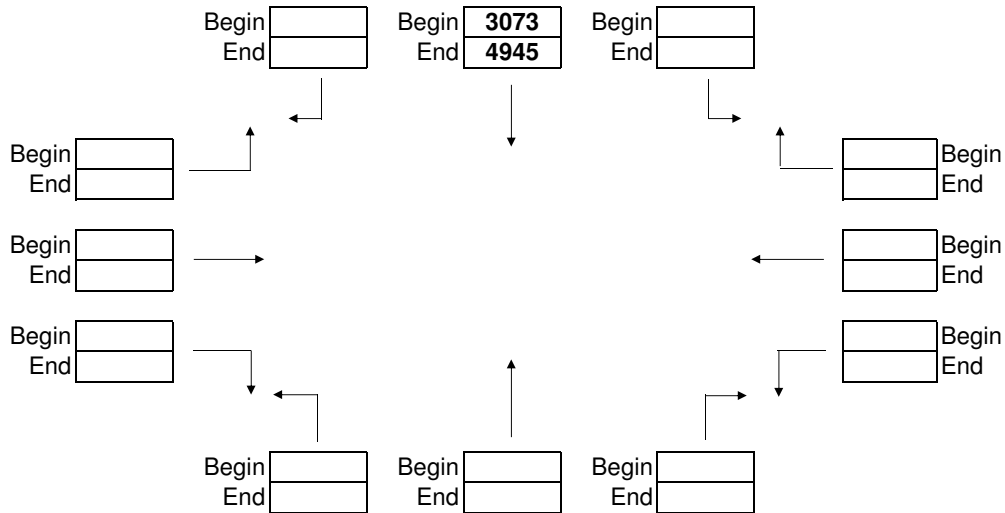

Year	Avg Delay in secs.	EB LT Volume	EB TH Volume	EB RT Volume	WB LT Volume	WB TH Volume	WB RT Volume	NB LT Volume	NB TH Volume	NB RT Volume	SB LT Volume	SB TH Volume	SB RT Volume
2011	0	0	0	0	0	0	0	0	0	0	0	3073	0
2012	0.0	0	0	0	0	0	0	0	0	0	0	3138	0
2013	0.0	0	0	0	0	0	0	0	0	0	0	3202	0
2014	0.0	0	0	0	0	0	0	0	0	0	0	3267	0
2015	0.0	0	0	0	0	0	0	0	0	0	0	3331	0
2016	0.0	0	0	0	0	0	0	0	0	0	0	3396	0
2017	0.0	0	0	0	0	0	0	0	0	0	0	3460	0
2018	0.0	0	0	0	0	0	0	0	0	0	0	3525	0
2019	0.0	0	0	0	0	0	0	0	0	0	0	3589	0
2020	0.0	0	0	0	0	0	0	0	0	0	0	3654	0
2021	0.0	0	0	0	0	0	0	0	0	0	0	3719	0
2022	0.0	0	0	0	0	0	0	0	0	0	0	3783	0
2023	0.0	0	0	0	0	0	0	0	0	0	0	3848	0
2024	0.0	0	0	0	0	0	0	0	0	0	0	3912	0
2025	0.0	0	0	0	0	0	0	0	0	0	0	3977	0
2026	0.0	0	0	0	0	0	0	0	0	0	0	4041	0
2027	0.0	0	0	0	0	0	0	0	0	0	0	4106	0
2028	0.0	0	0	0	0	0	0	0	0	0	0	4170	0
2029	0.0	0	0	0	0	0	0	0	0	0	0	4235	0
2030	0.0	0	0	0	0	0	0	0	0	0	0	4299	0
2031	0.0	0	0	0	0	0	0	0	0	0	0	4364	0
2032	0.0	0	0	0	0	0	0	0	0	0	0	4429	0
2033	0.0	0	0	0	0	0	0	0	0	0	0	4493	0
2034	0.0	0	0	0	0	0	0	0	0	0	0	4558	0
2035	0.0	0	0	0	0	0	0	0	0	0	0	4622	0
2036	0.0	0	0	0	0	0	0	0	0	0	0	4687	0
2037	0.0	0	0	0	0	0	0	0	0	0	0	4751	0
2038	0.0	0	0	0	0	0	0	0	0	0	0	4816	0
2039	0.0	0	0	0	0	0	0	0	0	0	0	4880	0

Note : Average Delay in seconds is not a straight line interpolation and should only be used as a reference.

Interpolating Intermediate Traffic Volumes

Location : I-26
Description : Build 6 Lane US 64 to Upward Rd

Input Beginning Year = Beginning Avg Delay =
 Input Ending Year = Ending Avg Delay =

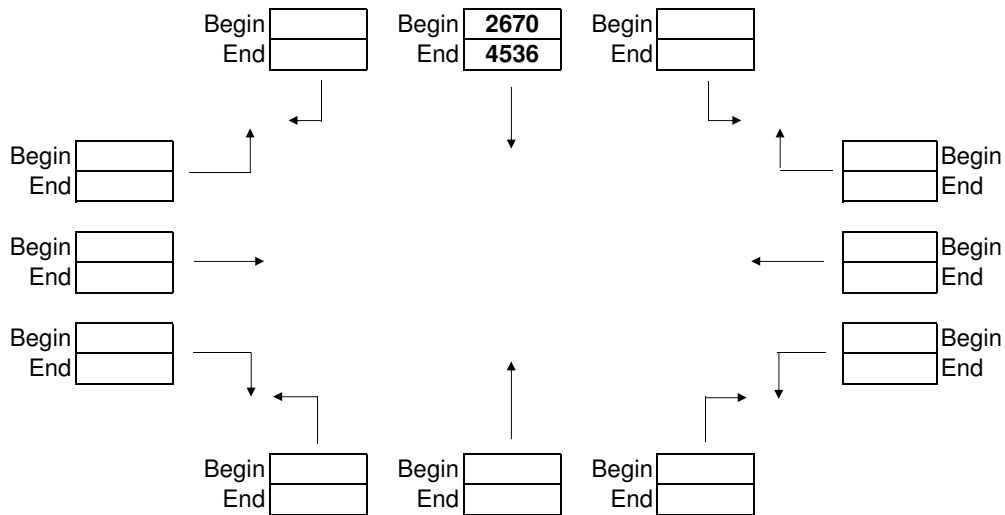

Year	Avg Delay in secs.	EB LT Volume	EB TH Volume	EB RT Volume	WB LT Volume	WB TH Volume	WB RT Volume	NB LT Volume	NB TH Volume	NB RT Volume	SB LT Volume	SB TH Volume	SB RT Volume
2011	0	0	0	0	0	0	0	0	0	0	0	2670	0
2012	0.0	0	0	0	0	0	0	0	0	0	0	2734	0
2013	0.0	0	0	0	0	0	0	0	0	0	0	2799	0
2014	0.0	0	0	0	0	0	0	0	0	0	0	2863	0
2015	0.0	0	0	0	0	0	0	0	0	0	0	2927	0
2016	0.0	0	0	0	0	0	0	0	0	0	0	2992	0
2017	0.0	0	0	0	0	0	0	0	0	0	0	3056	0
2018	0.0	0	0	0	0	0	0	0	0	0	0	3120	0
2019	0.0	0	0	0	0	0	0	0	0	0	0	3185	0
2020	0.0	0	0	0	0	0	0	0	0	0	0	3249	0
2021	0.0	0	0	0	0	0	0	0	0	0	0	3313	0
2022	0.0	0	0	0	0	0	0	0	0	0	0	3378	0
2023	0.0	0	0	0	0	0	0	0	0	0	0	3442	0
2024	0.0	0	0	0	0	0	0	0	0	0	0	3506	0
2025	0.0	0	0	0	0	0	0	0	0	0	0	3571	0
2026	0.0	0	0	0	0	0	0	0	0	0	0	3635	0
2027	0.0	0	0	0	0	0	0	0	0	0	0	3700	0
2028	0.0	0	0	0	0	0	0	0	0	0	0	3764	0
2029	0.0	0	0	0	0	0	0	0	0	0	0	3828	0
2030	0.0	0	0	0	0	0	0	0	0	0	0	3893	0
2031	0.0	0	0	0	0	0	0	0	0	0	0	3957	0
2032	0.0	0	0	0	0	0	0	0	0	0	0	4021	0
2033	0.0	0	0	0	0	0	0	0	0	0	0	4086	0
2034	0.0	0	0	0	0	0	0	0	0	0	0	4150	0
2035	0.0	0	0	0	0	0	0	0	0	0	0	4214	0
2036	0.0	0	0	0	0	0	0	0	0	0	0	4279	0
2037	0.0	0	0	0	0	0	0	0	0	0	0	4343	0
2038	0.0	0	0	0	0	0	0	0	0	0	0	4407	0
2039	0.0	0	0	0	0	0	0	0	0	0	0	4472	0

Note : Average Delay in seconds is not a straight line interpolation and should only be used as a reference.

Interpolating Intermediate Traffic Volumes

Location : I-26
Description : Build 8 Lane I-40 to NC 191

Input Beginning Year = Beginning Avg Delay =
 Input Ending Year = Ending Avg Delay =

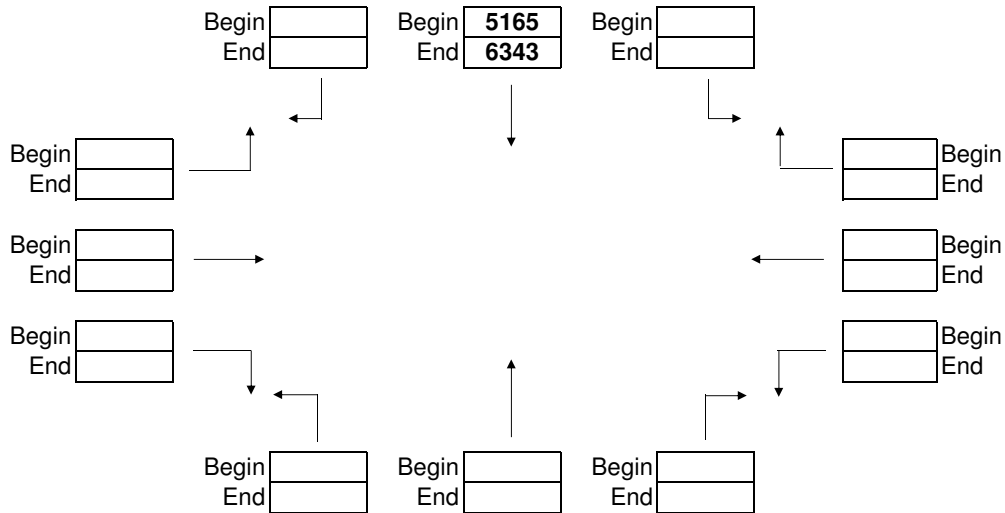

Year	Avg Delay in secs.	EB LT Volume	EB TH Volume	EB RT Volume	WB LT Volume	WB TH Volume	WB RT Volume	NB LT Volume	NB TH Volume	NB RT Volume	SB LT Volume	SB TH Volume	SB RT Volume
2011	0	0	0	0	0	0	0	0	0	0	0	5165	0
2012	0.0	0	0	0	0	0	0	0	0	0	0	5206	0
2013	0.0	0	0	0	0	0	0	0	0	0	0	5246	0
2014	0.0	0	0	0	0	0	0	0	0	0	0	5287	0
2015	0.0	0	0	0	0	0	0	0	0	0	0	5327	0
2016	0.0	0	0	0	0	0	0	0	0	0	0	5368	0
2017	0.0	0	0	0	0	0	0	0	0	0	0	5409	0
2018	0.0	0	0	0	0	0	0	0	0	0	0	5449	0
2019	0.0	0	0	0	0	0	0	0	0	0	0	5490	0
2020	0.0	0	0	0	0	0	0	0	0	0	0	5531	0
2021	0.0	0	0	0	0	0	0	0	0	0	0	5571	0
2022	0.0	0	0	0	0	0	0	0	0	0	0	5612	0
2023	0.0	0	0	0	0	0	0	0	0	0	0	5652	0
2024	0.0	0	0	0	0	0	0	0	0	0	0	5693	0
2025	0.0	0	0	0	0	0	0	0	0	0	0	5734	0
2026	0.0	0	0	0	0	0	0	0	0	0	0	5774	0
2027	0.0	0	0	0	0	0	0	0	0	0	0	5815	0
2028	0.0	0	0	0	0	0	0	0	0	0	0	5856	0
2029	0.0	0	0	0	0	0	0	0	0	0	0	5896	0
2030	0.0	0	0	0	0	0	0	0	0	0	0	5937	0
2031	0.0	0	0	0	0	0	0	0	0	0	0	5977	0
2032	0.0	0	0	0	0	0	0	0	0	0	0	6018	0
2033	0.0	0	0	0	0	0	0	0	0	0	0	6059	0
2034	0.0	0	0	0	0	0	0	0	0	0	0	6099	0
2035	0.0	0	0	0	0	0	0	0	0	0	0	6140	0
2036	0.0	0	0	0	0	0	0	0	0	0	0	6181	0
2037	0.0	0	0	0	0	0	0	0	0	0	0	6221	0
2038	0.0	0	0	0	0	0	0	0	0	0	0	6262	0
2039	0.0	0	0	0	0	0	0	0	0	0	0	6302	0

Note : Average Delay in seconds is not a straight line interpolation and should only be used as a reference.

Interpolating Intermediate Traffic Volumes

Location : I-26
Description : Build 8 Lane NC 146 to NC 280

Input Beginning Year = Beginning Avg Delay =
Input Ending Year = Ending Avg Delay =

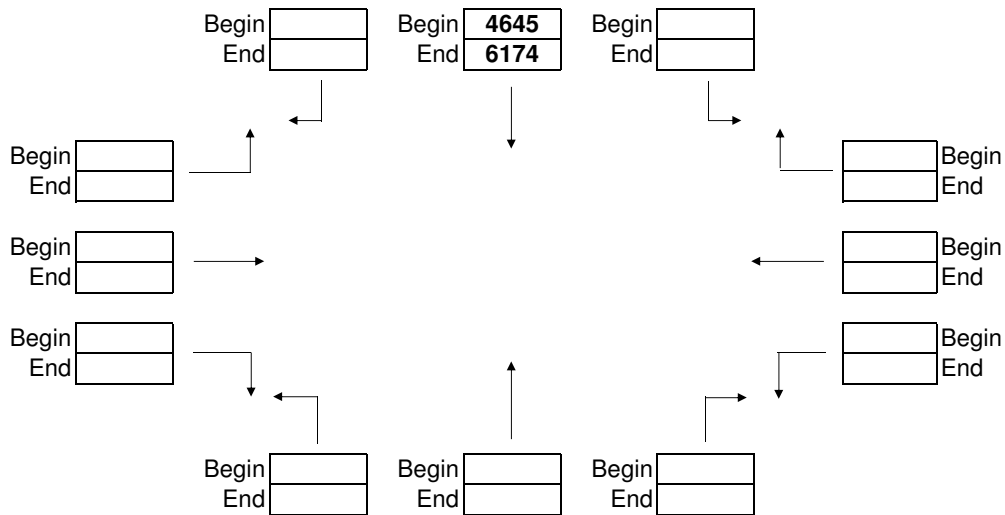

Year	Avg Delay in secs.	EB LT Volume	EB TH Volume	EB RT Volume	WB LT Volume	WB TH Volume	WB RT Volume	NB LT Volume	NB TH Volume	NB RT Volume	SB LT Volume	SB TH Volume	SB RT Volume
2011	0	0	0	0	0	0	0	0	0	0	0	4645	0
2012	0.0	0	0	0	0	0	0	0	0	0	0	4698	0
2013	0.0	0	0	0	0	0	0	0	0	0	0	4750	0
2014	0.0	0	0	0	0	0	0	0	0	0	0	4803	0
2015	0.0	0	0	0	0	0	0	0	0	0	0	4856	0
2016	0.0	0	0	0	0	0	0	0	0	0	0	4909	0
2017	0.0	0	0	0	0	0	0	0	0	0	0	4961	0
2018	0.0	0	0	0	0	0	0	0	0	0	0	5014	0
2019	0.0	0	0	0	0	0	0	0	0	0	0	5067	0
2020	0.0	0	0	0	0	0	0	0	0	0	0	5120	0
2021	0.0	0	0	0	0	0	0	0	0	0	0	5172	0
2022	0.0	0	0	0	0	0	0	0	0	0	0	5225	0
2023	0.0	0	0	0	0	0	0	0	0	0	0	5278	0
2024	0.0	0	0	0	0	0	0	0	0	0	0	5330	0
2025	0.0	0	0	0	0	0	0	0	0	0	0	5383	0
2026	0.0	0	0	0	0	0	0	0	0	0	0	5436	0
2027	0.0	0	0	0	0	0	0	0	0	0	0	5489	0
2028	0.0	0	0	0	0	0	0	0	0	0	0	5541	0
2029	0.0	0	0	0	0	0	0	0	0	0	0	5594	0
2030	0.0	0	0	0	0	0	0	0	0	0	0	5647	0
2031	0.0	0	0	0	0	0	0	0	0	0	0	5699	0
2032	0.0	0	0	0	0	0	0	0	0	0	0	5752	0
2033	0.0	0	0	0	0	0	0	0	0	0	0	5805	0
2034	0.0	0	0	0	0	0	0	0	0	0	0	5858	0
2035	0.0	0	0	0	0	0	0	0	0	0	0	5910	0
2036	0.0	0	0	0	0	0	0	0	0	0	0	5963	0
2037	0.0	0	0	0	0	0	0	0	0	0	0	6016	0
2038	0.0	0	0	0	0	0	0	0	0	0	0	6069	0
2039	0.0	0	0	0	0	0	0	0	0	0	0	6121	0

Note : Average Delay in seconds is not a straight line interpolation and should only be used as a reference.

Interpolating Intermediate Traffic Volumes

Location : I-26
Description : Build 8 Lane NC 280 to US 25

Input Beginning Year = Beginning Avg Delay =
Input Ending Year = Ending Avg Delay =

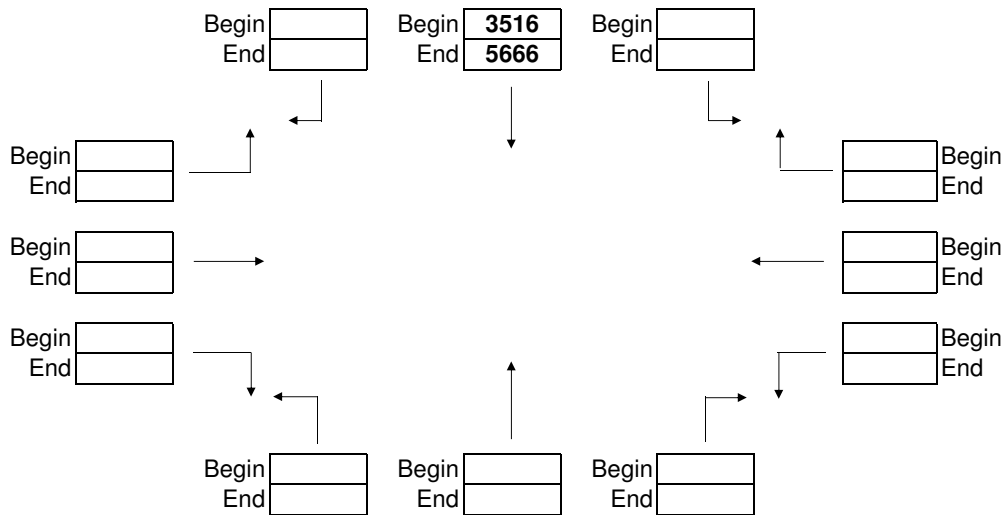

Year	Avg Delay in secs.	EB LT Volume	EB TH Volume	EB RT Volume	WB LT Volume	WB TH Volume	WB RT Volume	NB LT Volume	NB TH Volume	NB RT Volume	SB LT Volume	SB TH Volume	SB RT Volume
2011	0	0	0	0	0	0	0	0	0	0	0	3516	0
2012	0.0	0	0	0	0	0	0	0	0	0	0	3590	0
2013	0.0	0	0	0	0	0	0	0	0	0	0	3664	0
2014	0.0	0	0	0	0	0	0	0	0	0	0	3738	0
2015	0.0	0	0	0	0	0	0	0	0	0	0	3813	0
2016	0.0	0	0	0	0	0	0	0	0	0	0	3887	0
2017	0.0	0	0	0	0	0	0	0	0	0	0	3961	0
2018	0.0	0	0	0	0	0	0	0	0	0	0	4035	0
2019	0.0	0	0	0	0	0	0	0	0	0	0	4109	0
2020	0.0	0	0	0	0	0	0	0	0	0	0	4183	0
2021	0.0	0	0	0	0	0	0	0	0	0	0	4257	0
2022	0.0	0	0	0	0	0	0	0	0	0	0	4332	0
2023	0.0	0	0	0	0	0	0	0	0	0	0	4406	0
2024	0.0	0	0	0	0	0	0	0	0	0	0	4480	0
2025	0.0	0	0	0	0	0	0	0	0	0	0	4554	0
2026	0.0	0	0	0	0	0	0	0	0	0	0	4628	0
2027	0.0	0	0	0	0	0	0	0	0	0	0	4702	0
2028	0.0	0	0	0	0	0	0	0	0	0	0	4776	0
2029	0.0	0	0	0	0	0	0	0	0	0	0	4850	0
2030	0.0	0	0	0	0	0	0	0	0	0	0	4925	0
2031	0.0	0	0	0	0	0	0	0	0	0	0	4999	0
2032	0.0	0	0	0	0	0	0	0	0	0	0	5073	0
2033	0.0	0	0	0	0	0	0	0	0	0	0	5147	0
2034	0.0	0	0	0	0	0	0	0	0	0	0	5221	0
2035	0.0	0	0	0	0	0	0	0	0	0	0	5295	0
2036	0.0	0	0	0	0	0	0	0	0	0	0	5369	0
2037	0.0	0	0	0	0	0	0	0	0	0	0	5444	0
2038	0.0	0	0	0	0	0	0	0	0	0	0	5518	0
2039	0.0	0	0	0	0	0	0	0	0	0	0	5592	0

Note : Average Delay in seconds is not a straight line interpolation and should only be used as a reference.

Interpolating Intermediate Traffic Volumes

Location : I-26
Description : Build 8 Lane US 25 to US 64

Input Beginning Year = Beginning Avg Delay =
 Input Ending Year = Ending Avg Delay =

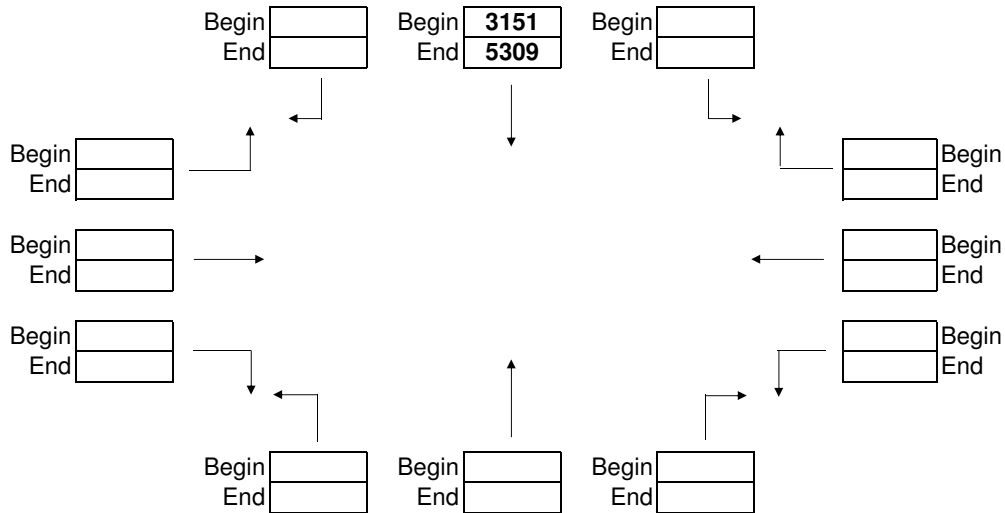

Year	Avg Delay in secs.	EB LT Volume	EB TH Volume	EB RT Volume	WB LT Volume	WB TH Volume	WB RT Volume	NB LT Volume	NB TH Volume	NB RT Volume	SB LT Volume	SB TH Volume	SB RT Volume
2011	0	0	0	0	0	0	0	0	0	0	0	3151	0
2012	0.0	0	0	0	0	0	0	0	0	0	0	3225	0
2013	0.0	0	0	0	0	0	0	0	0	0	0	3300	0
2014	0.0	0	0	0	0	0	0	0	0	0	0	3374	0
2015	0.0	0	0	0	0	0	0	0	0	0	0	3449	0
2016	0.0	0	0	0	0	0	0	0	0	0	0	3523	0
2017	0.0	0	0	0	0	0	0	0	0	0	0	3597	0
2018	0.0	0	0	0	0	0	0	0	0	0	0	3672	0
2019	0.0	0	0	0	0	0	0	0	0	0	0	3746	0
2020	0.0	0	0	0	0	0	0	0	0	0	0	3821	0
2021	0.0	0	0	0	0	0	0	0	0	0	0	3895	0
2022	0.0	0	0	0	0	0	0	0	0	0	0	3970	0
2023	0.0	0	0	0	0	0	0	0	0	0	0	4044	0
2024	0.0	0	0	0	0	0	0	0	0	0	0	4118	0
2025	0.0	0	0	0	0	0	0	0	0	0	0	4193	0
2026	0.0	0	0	0	0	0	0	0	0	0	0	4267	0
2027	0.0	0	0	0	0	0	0	0	0	0	0	4342	0
2028	0.0	0	0	0	0	0	0	0	0	0	0	4416	0
2029	0.0	0	0	0	0	0	0	0	0	0	0	4490	0
2030	0.0	0	0	0	0	0	0	0	0	0	0	4565	0
2031	0.0	0	0	0	0	0	0	0	0	0	0	4639	0
2032	0.0	0	0	0	0	0	0	0	0	0	0	4714	0
2033	0.0	0	0	0	0	0	0	0	0	0	0	4788	0
2034	0.0	0	0	0	0	0	0	0	0	0	0	4863	0
2035	0.0	0	0	0	0	0	0	0	0	0	0	4937	0
2036	0.0	0	0	0	0	0	0	0	0	0	0	5011	0
2037	0.0	0	0	0	0	0	0	0	0	0	0	5086	0
2038	0.0	0	0	0	0	0	0	0	0	0	0	5160	0
2039	0.0	0	0	0	0	0	0	0	0	0	0	5235	0

Note : Average Delay in seconds is not a straight line interpolation and should only be used as a reference.

Interpolating Intermediate Traffic Volumes

Location : I-26
Description : Build 8 Lane US 64 to Upward Rd

Input Beginning Year = Beginning Avg Delay =
 Input Ending Year = Ending Avg Delay =

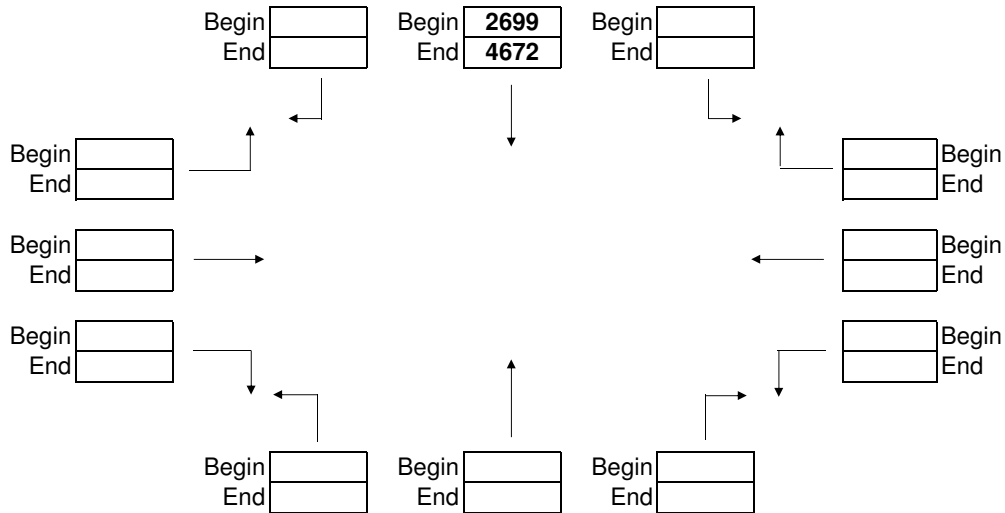

Year	Avg Delay in secs.	EB LT Volume	EB TH Volume	EB RT Volume	WB LT Volume	WB TH Volume	WB RT Volume	NB LT Volume	NB TH Volume	NB RT Volume	SB LT Volume	SB TH Volume	SB RT Volume
2011	0	0	0	0	0	0	0	0	0	0	0	2699	0
2012	0.0	0	0	0	0	0	0	0	0	0	0	2767	0
2013	0.0	0	0	0	0	0	0	0	0	0	0	2835	0
2014	0.0	0	0	0	0	0	0	0	0	0	0	2903	0
2015	0.0	0	0	0	0	0	0	0	0	0	0	2971	0
2016	0.0	0	0	0	0	0	0	0	0	0	0	3039	0
2017	0.0	0	0	0	0	0	0	0	0	0	0	3107	0
2018	0.0	0	0	0	0	0	0	0	0	0	0	3175	0
2019	0.0	0	0	0	0	0	0	0	0	0	0	3243	0
2020	0.0	0	0	0	0	0	0	0	0	0	0	3311	0
2021	0.0	0	0	0	0	0	0	0	0	0	0	3379	0
2022	0.0	0	0	0	0	0	0	0	0	0	0	3447	0
2023	0.0	0	0	0	0	0	0	0	0	0	0	3515	0
2024	0.0	0	0	0	0	0	0	0	0	0	0	3583	0
2025	0.0	0	0	0	0	0	0	0	0	0	0	3651	0
2026	0.0	0	0	0	0	0	0	0	0	0	0	3720	0
2027	0.0	0	0	0	0	0	0	0	0	0	0	3788	0
2028	0.0	0	0	0	0	0	0	0	0	0	0	3856	0
2029	0.0	0	0	0	0	0	0	0	0	0	0	3924	0
2030	0.0	0	0	0	0	0	0	0	0	0	0	3992	0
2031	0.0	0	0	0	0	0	0	0	0	0	0	4060	0
2032	0.0	0	0	0	0	0	0	0	0	0	0	4128	0
2033	0.0	0	0	0	0	0	0	0	0	0	0	4196	0
2034	0.0	0	0	0	0	0	0	0	0	0	0	4264	0
2035	0.0	0	0	0	0	0	0	0	0	0	0	4332	0
2036	0.0	0	0	0	0	0	0	0	0	0	0	4400	0
2037	0.0	0	0	0	0	0	0	0	0	0	0	4468	0
2038	0.0	0	0	0	0	0	0	0	0	0	0	4536	0
2039	0.0	0	0	0	0	0	0	0	0	0	0	4604	0

Note : Average Delay in seconds is not a straight line interpolation and should only be used as a reference.

No-Build

BASIC FREEWAY SEGMENTS WORKSHEET			
General Information		Site Information	
Analyst	BAR	Highway/Direction of Travel I-26	
Agency or Company	HNTB North Carolina, PC	From/To	I-40 to NC 191
Date Performed	7/12/2013	Jurisdiction	Buncombe County
Analysis Time Period	Peak	Analysis Year	2011 No Build
Project Description STIP I4400/I-4700 - I-26 Widening			
<input checked="" type="checkbox"/> Oper.(LOS)		<input type="checkbox"/> Des.(N)	
<input type="checkbox"/> Planning Data			
Flow Inputs			
Volume, V	4423	veh/h	Peak-Hour Factor, PHF 0.90
AADT		veh/day	%Trucks and Buses, P _T 6
Peak-Hr Prop. of AADT, K			%RVs, P _R 0
Peak-Hr Direction Prop, D			General Terrain: Rolling
DDHV = AADT x K x D		veh/h	Grade % Length mi
			Up/Down %
Calculate Flow Adjustments			
f _p	1.00	E _R	2.0
E _T	2.5	f _{HV} = 1/[1+P _T (E _T - 1) + P _R (E _R - 1)] 0.917	
Speed Inputs		Calc Speed Adj and FFS	
Lane Width	ft		
Rt-Side Lat. Clearance	ft	f _{LW}	mph
Number of Lanes, N	2	f _{LC}	mph
Total Ramp Density, TRD	ramps/mi	TRD Adjustment	mph
FFS (measured)	65.0	FFS	65.0
Base free-flow Speed, BFFS	mph		mph
LOS and Performance Measures		Design (N)	
<u>Operational (LOS)</u>		<u>Design (N)</u>	
v _p = (V or DDHV) / (PHF x N x f _{HV} x f _p)		Design LOS	
v _p	2678	v _p = (V or DDHV) / (PHF x N x f _{HV} x f _p)	pc/h/ln
S	41.8	S	mph
D = v _p / S	64.0	D = v _p / S	pc/mi/ln
LOS	F	Required Number of Lanes, N	
Glossary		Factor Location	
N - Number of lanes	S - Speed	E _R - Exhibits 11-10, 11-12	f _{LW} - Exhibit 11-8
V - Hourly volume	D - Density	E _T - Exhibits 11-10, 11-11, 11-13	f _{LC} - Exhibit 11-9
v _p - Flow rate	FFS - Free-flow speed	f _p - Page 11-18	TRD - Page 11-11
LOS - Level of service	BFFS - Base free-flow speed	LOS, S, FFS, v _p - Exhibits 11-2, 11-3	
DDHV - Directional design hour volume			

BASIC FREEWAY SEGMENTS WORKSHEET											
General Information		Site Information									
Analyst	BAR	Highway/Direction of Travel I-26									
Agency or Company	HNTB North Carolina, PC	From/To	NC 146 to NC 280								
Date Performed	7/12/2013	Jurisdiction	Buncombe County								
Analysis Time Period	Peak	Analysis Year	2011 No Build								
Project Description STIP I4400/I-4700 - I-26 Widening											
<input checked="" type="checkbox"/> Oper.(LOS)		<input type="checkbox"/> Des.(N)									
<input type="checkbox"/> Planning Data											
Flow Inputs											
Volume, V	3888	veh/h	Peak-Hour Factor, PHF 0.90								
AADT		veh/day	%Trucks and Buses, P _T 5								
Peak-Hr Prop. of AADT, K			%RVs, P _R 0								
Peak-Hr Direction Prop, D			General Terrain: Rolling								
DDHV = AADT x K x D		veh/h	Grade % Length mi Up/Down %								
Calculate Flow Adjustments											
f _p	1.00	E _R	2.0								
E _T	2.5	f _{HV} = 1/[1+P _T (E _T - 1) + P _R (E _R - 1)] 0.930									
Speed Inputs		Calc Speed Adj and FFS									
Lane Width	ft	<table style="width:100%; border-collapse: collapse;"> <tr> <td style="padding: 5px;">f_{LW}</td> <td style="padding: 5px;">mph</td> </tr> <tr> <td style="padding: 5px;">f_{LC}</td> <td style="padding: 5px;">mph</td> </tr> <tr> <td style="padding: 5px;">TRD Adjustment</td> <td style="padding: 5px;">mph</td> </tr> <tr> <td style="padding: 5px;">FFS</td> <td style="padding: 5px;">65.0 mph</td> </tr> </table>		f _{LW}	mph	f _{LC}	mph	TRD Adjustment	mph	FFS	65.0 mph
f _{LW}	mph										
f _{LC}	mph										
TRD Adjustment	mph										
FFS	65.0 mph										
Rt-Side Lat. Clearance	ft										
Number of Lanes, N	2										
Total Ramp Density, TRD	ramps/mi										
FFS (measured)	65.0 mph										
Base free-flow Speed, BFFS	mph										
LOS and Performance Measures		Design (N)									
<u>Operational (LOS)</u>		<u>Design (N)</u>									
v _p = (V or DDHV) / (PHF x N x f _{HV} x f _p)	2322 pc/h/ln	Design LOS									
S	52.9 mph	v _p = (V or DDHV) / (PHF x N x f _{HV} x f _p)	pc/h/ln								
D = v _p / S	43.9 pc/mi/ln	S	mph								
LOS	E	D = v _p / S	pc/mi/ln								
		Required Number of Lanes, N									
Glossary		Factor Location									
N - Number of lanes	S - Speed	E _R - Exhibits 11-10, 11-12	f _{LW} - Exhibit 11-8								
V - Hourly volume	D - Density	E _T - Exhibits 11-10, 11-11, 11-13	f _{LC} - Exhibit 11-9								
v _p - Flow rate	FFS - Free-flow speed	f _p - Page 11-18	TRD - Page 11-11								
LOS - Level of service speed	BFFS - Base free-flow speed	LOS, S, FFS, v _p - Exhibits 11-2, 11-3									
DDHV - Directional design hour volume											

BASIC FREEWAY SEGMENTS WORKSHEET			
General Information		Site Information	
Analyst	BAR	Highway/Direction of Travel I-26	
Agency or Company	HNTB North Carolina, PC	From/To	NC 280 to US 25
Date Performed	7/12/2013	Jurisdiction	Buncombe County
Analysis Time Period	Peak	Analysis Year	2011 No Build
Project Description STIP I4400/I-4700 - I-26 Widening			
<input checked="" type="checkbox"/> Oper.(LOS)		<input type="checkbox"/> Des.(N)	
<input type="checkbox"/> Planning Data			
Flow Inputs			
Volume, V	3074	veh/h	Peak-Hour Factor, PHF 0.90
AADT		veh/day	%Trucks and Buses, P _T 6
Peak-Hr Prop. of AADT, K			%RVs, P _R 0
Peak-Hr Direction Prop, D			General Terrain: Rolling
DDHV = AADT x K x D		veh/h	Grade % Length mi
			Up/Down %
Calculate Flow Adjustments			
f _p	1.00	E _R	2.0
E _T	2.5	f _{HV} = 1/[1+P _T (E _T - 1) + P _R (E _R - 1)] 0.917	
Speed Inputs		Calc Speed Adj and FFS	
Lane Width	ft		
Rt-Side Lat. Clearance	ft	f _{LW}	mph
Number of Lanes, N	2	f _{LC}	mph
Total Ramp Density, TRD	ramps/mi	TRD Adjustment	mph
FFS (measured)	65.0	FFS	65.0
Base free-flow Speed, BFFS	mph		mph
LOS and Performance Measures		Design (N)	
<u>Operational (LOS)</u>		<u>Design (N)</u>	
v _p = (V or DDHV) / (PHF x N x f _{HV} x f _p)		Design LOS	
1861	pc/h/ln	v _p = (V or DDHV) / (PHF x N x f _{HV} x f _p)	
S	62.0	mph	pc/h/ln
D = v _p / S	30.0	pc/mi/ln	S
LOS	D	D = v _p / S	
		pc/mi/ln	
		Required Number of Lanes, N	
Glossary		Factor Location	
N - Number of lanes	S - Speed	E _R - Exhibits 11-10, 11-12	f _{LW} - Exhibit 11-8
V - Hourly volume	D - Density	E _T - Exhibits 11-10, 11-11, 11-13	f _{LC} - Exhibit 11-9
v _p - Flow rate	FFS - Free-flow speed	f _p - Page 11-18	TRD - Page 11-11
LOS - Level of service	BFFS - Base free-flow speed	LOS, S, FFS, v _p - Exhibits 11-2, 11-3	
DDHV - Directional design hour volume			

BASIC FREEWAY SEGMENTS WORKSHEET			
General Information		Site Information	
Analyst	BAR	Highway/Direction of Travel	I-26
Agency or Company	HNTB North Carolina, PC	From/To	US 25 to US 64
Date Performed	7/12/2013	Jurisdiction	Buncombe County
Analysis Time Period	Peak	Analysis Year	2011 No Build
Project Description <i>STIP I4400/I-4700 - I-26 Widening</i>			
<input checked="" type="checkbox"/> Oper.(LOS)		<input type="checkbox"/> Des.(N)	<input type="checkbox"/> Planning Data
Flow Inputs			
Volume, V	2810	veh/h	Peak-Hour Factor, PHF
AADT		veh/day	0.90
Peak-Hr Prop. of AADT, K			%Trucks and Buses, P _T
Peak-Hr Direction Prop, D			6
DDHV = AADT x K x D		veh/h	%RVs, P _R
			0
			General Terrain:
			Rolling
			Grade % Length
			mi
			Up/Down %
Calculate Flow Adjustments			
f _p	1.00	E _R	2.0
E _T	2.5	f _{HV} = 1/[1+P _T (E _T - 1) + P _R (E _R - 1)]	0.917
Speed Inputs		Calc Speed Adj and FFS	
Lane Width	ft		
Rt-Side Lat. Clearance	ft	f _{LW}	mph
Number of Lanes, N	2	f _{LC}	mph
Total Ramp Density, TRD	ramps/mi	TRD Adjustment	mph
FFS (measured)	70.0	FFS	70.0
Base free-flow Speed, BFFS	mph		
LOS and Performance Measures		Design (N)	
<u>Operational (LOS)</u>		<u>Design (N)</u>	
v _p = (V or DDHV) / (PHF x N x f _{HV} x f _p)		Design LOS	
1702	pc/h/ln	v _p = (V or DDHV) / (PHF x N x f _{HV} x f _p)	
S	67.1	pc/h/ln	
D = v _p / S	25.4	S	
LOS	C	mph	
		D = v _p / S	
		pc/mi/ln	
		Required Number of Lanes, N	
Glossary		Factor Location	
N - Number of lanes	S - Speed	E _R - Exhibits 11-10, 11-12	f _{LW} - Exhibit 11-8
V - Hourly volume	D - Density	E _T - Exhibits 11-10, 11-11, 11-13	f _{LC} - Exhibit 11-9
v _p - Flow rate	FFS - Free-flow speed	f _p - Page 11-18	TRD - Page 11-11
LOS - Level of service	BFFS - Base free-flow speed	LOS, S, FFS, v _p - Exhibits 11-2, 11-3	
DDHV - Directional design hour volume			

BASIC FREEWAY SEGMENTS WORKSHEET			
General Information		Site Information	
Analyst	BAR	Highway/Direction of Travel	I-26
Agency or Company	HNTB North Carolina, PC	From/To	US 64 to Upward Road
Date Performed	7/12/2013	Jurisdiction	Buncombe County
Analysis Time Period	Peak	Analysis Year	2011 No Build
Project Description <i>STIP I4400/I-4700 - I-26 Widening</i>			
<input checked="" type="checkbox"/> Oper.(LOS)		<input type="checkbox"/> Des.(N)	
<input type="checkbox"/> Planning Data			
Flow Inputs			
Volume, V	2619	veh/h	Peak-Hour Factor, PHF
AADT		veh/day	0.90
Peak-Hr Prop. of AADT, K			%Trucks and Buses, P _T
Peak-Hr Direction Prop, D			6
DDHV = AADT x K x D		veh/h	%RVs, P _R
			0
			General Terrain:
			Rolling
			Grade % Length
			mi
			Up/Down %
Calculate Flow Adjustments			
f _p	1.00	E _R	2.0
E _T	2.5	f _{HV} = 1/[1+P _T (E _T - 1) + P _R (E _R - 1)]	
Speed Inputs		Calc Speed Adj and FFS	
Lane Width	ft		
Rt-Side Lat. Clearance	ft	f _{LW}	mph
Number of Lanes, N	2	f _{LC}	mph
Total Ramp Density, TRD	ramps/mi	TRD Adjustment	mph
FFS (measured)	70.0	FFS	70.0
Base free-flow Speed, BFFS	mph		
LOS and Performance Measures		Design (N)	
<u>Operational (LOS)</u>		<u>Design (N)</u>	
v _p = (V or DDHV) / (PHF x N x f _{HV} x f _p)		Design LOS	
1586	pc/h/ln	v _p = (V or DDHV) / (PHF x N x f _{HV} x f _p)	
S	68.3	pc/h/ln	
D = v _p / S	23.2	S	
LOS	C	mph	
		D = v _p / S	
		pc/mi/ln	
		Required Number of Lanes, N	
Glossary		Factor Location	
N - Number of lanes	S - Speed	E _R - Exhibits 11-10, 11-12	f _{LW} - Exhibit 11-8
V - Hourly volume	D - Density	E _T - Exhibits 11-10, 11-11, 11-13	f _{LC} - Exhibit 11-9
v _p - Flow rate	FFS - Free-flow speed	f _p - Page 11-18	TRD - Page 11-11
LOS - Level of service	BFFS - Base free-flow speed	LOS, S, FFS, v _p - Exhibits 11-2, 11-3	
DDHV - Directional design hour volume			

BASIC FREEWAY SEGMENTS WORKSHEET			
General Information		Site Information	
Analyst	BAR	Highway/Direction of Travel	I-26
Agency or Company	HNTB North Carolina, PC	From/To	I 40 to NC 191
Date Performed	7/12/2013	Jurisdiction	Buncombe County
Analysis Time Period	Peak	Analysis Year	2015 No Build
Project Description <i>STIP I4400/I-4700 - I-26 Widening</i>			
<input checked="" type="checkbox"/> Oper.(LOS)		<input type="checkbox"/> Des.(N)	
<input type="checkbox"/> Planning Data			
Flow Inputs			
Volume, V	4493	veh/h	Peak-Hour Factor, PHF
AADT		veh/day	0.90
Peak-Hr Prop. of AADT, K			%Trucks and Buses, P _T
Peak-Hr Direction Prop, D			6
DDHV = AADT x K x D		veh/h	%RVs, P _R
			0
			General Terrain:
			Rolling
			Grade % Length
			mi
			Up/Down %
Calculate Flow Adjustments			
f _p	1.00	E _R	2.0
E _T	2.5	f _{HV} = 1/[1+P _T (E _T - 1) + P _R (E _R - 1)]	0.917
Speed Inputs		Calc Speed Adj and FFS	
Lane Width	ft		
Rt-Side Lat. Clearance	ft	f _{LW}	mph
Number of Lanes, N	2	f _{LC}	mph
Total Ramp Density, TRD	ramps/mi	TRD Adjustment	mph
FFS (measured)	65.0	FFS	65.0
Base free-flow Speed, BFFS	mph		mph
LOS and Performance Measures		Design (N)	
<u>Operational (LOS)</u>		<u>Design (N)</u>	
v _p = (V or DDHV) / (PHF x N x f _{HV})		Design LOS	
2721	pc/h/ln	v _p = (V or DDHV) / (PHF x N x f _{HV})	
x f _p)		pc/h/ln	
S	40.3	x f _p)	
D = v _p / S	67.6	S	
LOS	F	mph	
		D = v _p / S	
		pc/mi/ln	
		Required Number of Lanes, N	
Glossary		Factor Location	
N - Number of lanes	S - Speed	E _R - Exhibits 11-10, 11-12	f _{LW} - Exhibit 11-8
V - Hourly volume	D - Density	E _T - Exhibits 11-10, 11-11, 11-13	f _{LC} - Exhibit 11-9
v _p - Flow rate	FFS - Free-flow speed	f _p - Page 11-18	TRD - Page 11-11
LOS - Level of service	BFFS - Base free-flow speed	LOS, S, FFS, v _p - Exhibits 11-2, 11-3	
DDHV - Directional design hour volume			

BASIC FREEWAY SEGMENTS WORKSHEET											
General Information		Site Information									
Analyst	BAR	Highway/Direction of Travel I-26									
Agency or Company	HNTB North Carolina, PC	From/To	NC 146 to NC 280								
Date Performed	7/12/2013	Jurisdiction	Buncombe County								
Analysis Time Period	Peak	Analysis Year	2015 No Build								
Project Description STIP I4400/I-4700 - I-26 Widening											
<input checked="" type="checkbox"/> Oper.(LOS)		<input type="checkbox"/> Des.(N)									
<input type="checkbox"/> Planning Data											
Flow Inputs											
Volume, V	3977	veh/h	Peak-Hour Factor, PHF 0.90								
AADT		veh/day	%Trucks and Buses, P _T 5								
Peak-Hr Prop. of AADT, K			%RVs, P _R 0								
Peak-Hr Direction Prop, D			General Terrain: Rolling								
DDHV = AADT x K x D		veh/h	Grade % Length mi								
			Up/Down %								
Calculate Flow Adjustments											
f _p	1.00	E _R	2.0								
E _T	2.5	f _{HV} = 1/[1+P _T (E _T - 1) + P _R (E _R - 1)] 0.930									
Speed Inputs		Calc Speed Adj and FFS									
Lane Width	ft	<table style="width:100%; border-collapse: collapse;"> <tr> <td style="padding: 5px;">f_{LW}</td> <td style="padding: 5px;">mph</td> </tr> <tr> <td style="padding: 5px;">f_{LC}</td> <td style="padding: 5px;">mph</td> </tr> <tr> <td style="padding: 5px;">TRD Adjustment</td> <td style="padding: 5px;">mph</td> </tr> <tr> <td style="padding: 5px;">FFS</td> <td style="padding: 5px;">65.0 mph</td> </tr> </table>		f _{LW}	mph	f _{LC}	mph	TRD Adjustment	mph	FFS	65.0 mph
f _{LW}	mph										
f _{LC}	mph										
TRD Adjustment	mph										
FFS	65.0 mph										
Rt-Side Lat. Clearance	ft										
Number of Lanes, N	2										
Total Ramp Density, TRD	ramps/mi										
FFS (measured)	65.0 mph										
Base free-flow Speed, BFFS	mph										
LOS and Performance Measures		Design (N)									
<u>Operational (LOS)</u>		<u>Design (N)</u>									
v _p = (V or DDHV) / (PHF x N x f _{HV} x f _p)	2375 pc/h/ln	Design LOS									
S	51.5 mph	v _p = (V or DDHV) / (PHF x N x f _{HV} x f _p)	pc/h/ln								
D = v _p / S	46.1 pc/mi/ln	S	mph								
LOS	F	D = v _p / S	pc/mi/ln								
		Required Number of Lanes, N									
Glossary		Factor Location									
N - Number of lanes	S - Speed	E _R - Exhibits 11-10, 11-12	f _{LW} - Exhibit 11-8								
V - Hourly volume	D - Density	E _T - Exhibits 11-10, 11-11, 11-13	f _{LC} - Exhibit 11-9								
v _p - Flow rate	FFS - Free-flow speed	f _p - Page 11-18	TRD - Page 11-11								
LOS - Level of service speed	BFFS - Base free-flow speed	LOS, S, FFS, v _p - Exhibits 11-2, 11-3									
DDHV - Directional design hour volume											

BASIC FREEWAY SEGMENTS WORKSHEET			
General Information		Site Information	
Analyst	BAR	Highway/Direction of Travel I-26	
Agency or Company	HNTB North Carolina, PC	From/To	NC 280 to US 25
Date Performed	7/12/2013	Jurisdiction	Buncombe County
Analysis Time Period	Peak	Analysis Year	2015 No Build
Project Description STIP I4400/I-4700 - I-26 Widening			
<input checked="" type="checkbox"/> Oper.(LOS)		<input type="checkbox"/> Des.(N)	
<input type="checkbox"/> Planning Data			
Flow Inputs			
Volume, V	3252	veh/h	Peak-Hour Factor, PHF 0.90
AADT		veh/day	%Trucks and Buses, P _T 6
Peak-Hr Prop. of AADT, K			%RVs, P _R 0
Peak-Hr Direction Prop, D			General Terrain: Rolling
DDHV = AADT x K x D		veh/h	Grade % Length mi
			Up/Down %
Calculate Flow Adjustments			
f _p	1.00	E _R	2.0
E _T	2.5	f _{HV} = 1/[1+P _T (E _T - 1) + P _R (E _R - 1)] 0.917	
Speed Inputs		Calc Speed Adj and FFS	
Lane Width	ft		
Rt-Side Lat. Clearance	ft	f _{LW}	mph
Number of Lanes, N	2	f _{LC}	mph
Total Ramp Density, TRD	ramps/mi	TRD Adjustment	mph
FFS (measured)	65.0	FFS	65.0
Base free-flow Speed, BFFS	mph		mph
LOS and Performance Measures		Design (N)	
<u>Operational (LOS)</u>		<u>Design (N)</u>	
v _p = (V or DDHV) / (PHF x N x f _{HV} x f _p)		Design LOS	
v _p	1969	v _p = (V or DDHV) / (PHF x N x f _{HV} x f _p)	pc/h/ln
S	60.4	S	mph
D = v _p / S	32.6	D = v _p / S	pc/mi/ln
LOS	D	Required Number of Lanes, N	
Glossary		Factor Location	
N - Number of lanes	S - Speed	E _R - Exhibits 11-10, 11-12	f _{LW} - Exhibit 11-8
V - Hourly volume	D - Density	E _T - Exhibits 11-10, 11-11, 11-13	f _{LC} - Exhibit 11-9
v _p - Flow rate	FFS - Free-flow speed	f _p - Page 11-18	TRD - Page 11-11
LOS - Level of service	BFFS - Base free-flow speed	LOS, S, FFS, v _p - Exhibits 11-2, 11-3	
DDHV - Directional design hour volume			

BASIC FREEWAY SEGMENTS WORKSHEET			
General Information		Site Information	
Analyst	BAR	Highway/Direction of Travel	I-26
Agency or Company	HNTB North Carolina, PC	From/To	US 25 to US 64
Date Performed	7/12/2013	Jurisdiction	Buncombe County
Analysis Time Period	Peak	Analysis Year	2015 No Build
Project Description <i>STIP I4400/I-4700 - I-26 Widening</i>			
<input checked="" type="checkbox"/> Oper.(LOS)		<input type="checkbox"/> Des.(N)	
<input type="checkbox"/> Planning Data			
Flow Inputs			
Volume, V	2967	veh/h	Peak-Hour Factor, PHF
AADT		veh/day	0.90
Peak-Hr Prop. of AADT, K			%Trucks and Buses, P _T
Peak-Hr Direction Prop, D			6
DDHV = AADT x K x D		veh/h	%RVs, P _R
			0
			General Terrain:
			Rolling
			Grade % Length
			mi
			Up/Down %
Calculate Flow Adjustments			
f _p	1.00	E _R	2.0
E _T	2.5	f _{HV} = 1/[1+P _T (E _T - 1) + P _R (E _R - 1)]	0.917
Speed Inputs		Calc Speed Adj and FFS	
Lane Width	ft		
Rt-Side Lat. Clearance	ft	f _{LW}	mph
Number of Lanes, N	2	f _{LC}	mph
Total Ramp Density, TRD	ramps/mi	TRD Adjustment	mph
FFS (measured)	70.0	FFS	70.0
Base free-flow Speed, BFFS	mph		mph
LOS and Performance Measures		Design (N)	
<u>Operational (LOS)</u>		<u>Design (N)</u>	
v _p = (V or DDHV) / (PHF x N x f _{HV} x f _p)		Design LOS	
1797	pc/h/ln	v _p = (V or DDHV) / (PHF x N x f _{HV} x f _p)	
S	65.9	pc/h/ln	
D = v _p / S	27.3	S	
LOS	D	mph	
		D = v _p / S	
		pc/mi/ln	
		Required Number of Lanes, N	
Glossary		Factor Location	
N - Number of lanes	S - Speed	E _R - Exhibits 11-10, 11-12	f _{LW} - Exhibit 11-8
V - Hourly volume	D - Density	E _T - Exhibits 11-10, 11-11, 11-13	f _{LC} - Exhibit 11-9
v _p - Flow rate	FFS - Free-flow speed	f _p - Page 11-18	TRD - Page 11-11
LOS - Level of service	BFFS - Base free-flow speed	LOS, S, FFS, v _p - Exhibits 11-2, 11-3	
DDHV - Directional design hour volume			

BASIC FREEWAY SEGMENTS WORKSHEET			
General Information		Site Information	
Analyst	BAR	Highway/Direction of Travel	I-26
Agency or Company	HNTB North Carolina, PC	From/To	US 64 to Upward Road
Date Performed	7/12/2013	Jurisdiction	Buncombe County
Analysis Time Period	Peak	Analysis Year	2015 No Build
Project Description STIP I4400/I-4700 - I-26 Widening			
<input checked="" type="checkbox"/> Oper.(LOS)		<input type="checkbox"/> Des.(N)	<input type="checkbox"/> Planning Data
Flow Inputs			
Volume, V	2795	veh/h	Peak-Hour Factor, PHF 0.90
AADT		veh/day	%Trucks and Buses, P _T 6
Peak-Hr Prop. of AADT, K			%RVs, P _R 0
Peak-Hr Direction Prop, D			General Terrain: Rolling
DDHV = AADT x K x D		veh/h	Grade % Length mi
			Up/Down %
Calculate Flow Adjustments			
f _p	1.00	E _R	2.0
E _T	2.5	f _{HV} = 1/[1+P _T (E _T - 1) + P _R (E _R - 1)]	0.917
Speed Inputs		Calc Speed Adj and FFS	
Lane Width		ft	
Rt-Side Lat. Clearance		ft	f _{LW} mph
Number of Lanes, N	2		f _{LC} mph
Total Ramp Density, TRD		ramps/mi	TRD Adjustment mph
FFS (measured)	70.0	mph	FFS 70.0 mph
Base free-flow Speed, BFFS		mph	
LOS and Performance Measures		Design (N)	
<u>Operational (LOS)</u>		<u>Design (N)</u>	
v _p = (V or DDHV) / (PHF x N x f _{HV} x f _p)		Design LOS	
	1693	pc/h/ln	v _p = (V or DDHV) / (PHF x N x f _{HV} x f _p)
S	67.2	mph	S
D = v _p / S	25.2	pc/mi/ln	D = v _p / S
LOS	C		Required Number of Lanes, N
Glossary		Factor Location	
N - Number of lanes	S - Speed	E _R - Exhibits 11-10, 11-12	f _{LW} - Exhibit 11-8
V - Hourly volume	D - Density	E _T - Exhibits 11-10, 11-11, 11-13	f _{LC} - Exhibit 11-9
v _p - Flow rate	FFS - Free-flow speed	f _p - Page 11-18	TRD - Page 11-11
LOS - Level of service	BFFS - Base free-flow speed	LOS, S, FFS, v _p - Exhibits 11-2, 11-3	
DDHV - Directional design hour volume			

BASIC FREEWAY SEGMENTS WORKSHEET			
General Information		Site Information	
Analyst	BAR	Highway/Direction of Travel	I-26
Agency or Company	HNTB North Carolina, PC	From/To	I 40 to NC 191
Date Performed	7/12/2013	Jurisdiction	Buncombe County
Analysis Time Period	Peak	Analysis Year	2020 No Build
Project Description <i>STIP I4400/I-4700 - I-26 Widening</i>			
<input checked="" type="checkbox"/> Oper.(LOS)		<input type="checkbox"/> Des.(N)	
<input type="checkbox"/> Planning Data			
Flow Inputs			
Volume, V	4579	veh/h	Peak-Hour Factor, PHF
AADT		veh/day	0.90
Peak-Hr Prop. of AADT, K			%Trucks and Buses, P _T
Peak-Hr Direction Prop, D			6
DDHV = AADT x K x D		veh/h	%RVs, P _R
			0
			General Terrain:
			Rolling
			Grade % Length
			mi
			Up/Down %
Calculate Flow Adjustments			
f _p	1.00	E _R	2.0
E _T	2.5	f _{HV} = 1/[1+P _T (E _T - 1) + P _R (E _R - 1)]	
Speed Inputs		Calc Speed Adj and FFS	
Lane Width	ft		
Rt-Side Lat. Clearance	ft	f _{LW}	mph
Number of Lanes, N	2	f _{LC}	mph
Total Ramp Density, TRD	ramps/mi	TRD Adjustment	mph
FFS (measured)	65.0	FFS	65.0
Base free-flow Speed, BFFS	mph		mph
LOS and Performance Measures		Design (N)	
<u>Operational (LOS)</u>		<u>Design (N)</u>	
v _p = (V or DDHV) / (PHF x N x f _{HV})		Design LOS	
2773	pc/h/ln	v _p = (V or DDHV) / (PHF x N x f _{HV})	
x f _p)		pc/h/ln	
S	38.3	x f _p)	
S	mph	S	mph
D = v _p / S	72.5	D = v _p / S	pc/mi/ln
72.5	pc/mi/ln	Required Number of Lanes, N	
LOS	F		
Glossary		Factor Location	
N - Number of lanes	S - Speed	E _R - Exhibits 11-10, 11-12	f _{LW} - Exhibit 11-8
V - Hourly volume	D - Density	E _T - Exhibits 11-10, 11-11, 11-13	f _{LC} - Exhibit 11-9
v _p - Flow rate	FFS - Free-flow speed	f _p - Page 11-18	TRD - Page 11-11
LOS - Level of service	BFFS - Base free-flow speed	LOS, S, FFS, v _p - Exhibits 11-2, 11-3	
DDHV - Directional design hour volume			

BASIC FREEWAY SEGMENTS WORKSHEET											
General Information		Site Information									
Analyst	BAR	Highway/Direction of Travel I-26									
Agency or Company	HNTB North Carolina, PC	From/To	NC 146 to NC 280								
Date Performed	7/12/2013	Jurisdiction	Buncombe County								
Analysis Time Period	Peak	Analysis Year	2020 No Build								
Project Description STIP I4400/I-4700 - I-26 Widening											
<input checked="" type="checkbox"/> Oper.(LOS)		<input type="checkbox"/> Des.(N)									
<input type="checkbox"/> Planning Data											
Flow Inputs											
Volume, V	4088	veh/h	Peak-Hour Factor, PHF 0.90								
AADT		veh/day	%Trucks and Buses, P _T 5								
Peak-Hr Prop. of AADT, K			%RVs, P _R 0								
Peak-Hr Direction Prop, D			General Terrain: Rolling								
DDHV = AADT x K x D		veh/h	Grade % Length mi								
			Up/Down %								
Calculate Flow Adjustments											
f _p	1.00	E _R	2.0								
E _T	2.5	f _{HV} = 1/[1+P _T (E _T - 1) + P _R (E _R - 1)] 0.930									
Speed Inputs		Calc Speed Adj and FFS									
Lane Width	ft	<table style="width:100%; border-collapse: collapse;"> <tr> <td style="padding: 5px;">f_{LW}</td> <td style="padding: 5px;">mph</td> </tr> <tr> <td style="padding: 5px;">f_{LC}</td> <td style="padding: 5px;">mph</td> </tr> <tr> <td style="padding: 5px;">TRD Adjustment</td> <td style="padding: 5px;">mph</td> </tr> <tr> <td style="padding: 5px;">FFS</td> <td style="padding: 5px;">65.0 mph</td> </tr> </table>		f _{LW}	mph	f _{LC}	mph	TRD Adjustment	mph	FFS	65.0 mph
f _{LW}	mph										
f _{LC}	mph										
TRD Adjustment	mph										
FFS	65.0 mph										
Rt-Side Lat. Clearance	ft										
Number of Lanes, N	2										
Total Ramp Density, TRD	ramps/mi										
FFS (measured)	65.0 mph										
Base free-flow Speed, BFFS	mph										
LOS and Performance Measures		Design (N)									
<u>Operational (LOS)</u>		<u>Design (N)</u>									
v _p = (V or DDHV) / (PHF x N x f _{HV} x f _p)	2441 pc/h/ln	Design LOS									
S	49.6 mph	v _p = (V or DDHV) / (PHF x N x f _{HV} x f _p)	pc/h/ln								
D = v _p / S	49.2 pc/mi/ln	S	mph								
LOS	F	D = v _p / S	pc/mi/ln								
		Required Number of Lanes, N									
Glossary		Factor Location									
N - Number of lanes	S - Speed	E _R - Exhibits 11-10, 11-12	f _{LW} - Exhibit 11-8								
V - Hourly volume	D - Density	E _T - Exhibits 11-10, 11-11, 11-13	f _{LC} - Exhibit 11-9								
v _p - Flow rate	FFS - Free-flow speed	f _p - Page 11-18	TRD - Page 11-11								
LOS - Level of service	BFFS - Base free-flow speed	LOS, S, FFS, v _p - Exhibits 11-2, 11-3									
DDHV - Directional design hour volume											

BASIC FREEWAY SEGMENTS WORKSHEET			
General Information		Site Information	
Analyst	BAR	Highway/Direction of Travel I-26	
Agency or Company	HNTB North Carolina, PC	From/To	NC 280 to US 25
Date Performed	7/12/2013	Jurisdiction	Buncombe County
Analysis Time Period	Peak	Analysis Year	2020 No Build
Project Description STIP I4400/I-4700 - I-26 Widening			
<input checked="" type="checkbox"/> Oper.(LOS)		<input type="checkbox"/> Des.(N)	
<input type="checkbox"/> Planning Data			
Flow Inputs			
Volume, V	3475	veh/h	Peak-Hour Factor, PHF 0.90
AADT		veh/day	%Trucks and Buses, P _T 6
Peak-Hr Prop. of AADT, K			%RVs, P _R 0
Peak-Hr Direction Prop, D			General Terrain: Rolling
DDHV = AADT x K x D		veh/h	Grade % Length mi
			Up/Down %
Calculate Flow Adjustments			
f _p	1.00	E _R	2.0
E _T	2.5	f _{HV} = 1/[1+P _T (E _T - 1) + P _R (E _R - 1)] 0.917	
Speed Inputs		Calc Speed Adj and FFS	
Lane Width	ft		
Rt-Side Lat. Clearance	ft	f _{LW}	mph
Number of Lanes, N	2	f _{LC}	mph
Total Ramp Density, TRD	ramps/mi	TRD Adjustment	mph
FFS (measured)	65.0	FFS	65.0
Base free-flow Speed, BFFS	mph		mph
LOS and Performance Measures		Design (N)	
<u>Operational (LOS)</u>		<u>Design (N)</u>	
v _p = (V or DDHV) / (PHF x N x f _{HV} x f _p)	2104 pc/h/ln	Design LOS	
S	58.0 mph	v _p = (V or DDHV) / (PHF x N x f _{HV} x f _p)	pc/h/ln
D = v _p / S	36.3 pc/mi/ln	S	mph
LOS	E	D = v _p / S	pc/mi/ln
		Required Number of Lanes, N	
Glossary		Factor Location	
N - Number of lanes	S - Speed	E _R - Exhibits 11-10, 11-12	f _{LW} - Exhibit 11-8
V - Hourly volume	D - Density	E _T - Exhibits 11-10, 11-11, 11-13	f _{LC} - Exhibit 11-9
v _p - Flow rate	FFS - Free-flow speed	f _p - Page 11-18	TRD - Page 11-11
LOS - Level of service	BFFS - Base free-flow speed	LOS, S, FFS, v _p - Exhibits 11-2, 11-3	
DDHV - Directional design hour volume			

BASIC FREEWAY SEGMENTS WORKSHEET			
General Information		Site Information	
Analyst	BAR	Highway/Direction of Travel	I-26
Agency or Company	HNTB North Carolina, PC	From/To	US 25 to US 64
Date Performed	7/12/2013	Jurisdiction	Buncombe County
Analysis Time Period	Peak	Analysis Year	2020 No Build
Project Description <i>STIP I4400/I-4700 - I-26 Widening</i>			
<input checked="" type="checkbox"/> Oper.(LOS)		<input type="checkbox"/> Des.(N)	<input type="checkbox"/> Planning Data
Flow Inputs			
Volume, V	3162	veh/h	Peak-Hour Factor, PHF
AADT		veh/day	0.90
Peak-Hr Prop. of AADT, K			%Trucks and Buses, P _T
Peak-Hr Direction Prop, D			6
DDHV = AADT x K x D		veh/h	%RVs, P _R
			0
			General Terrain:
			Rolling
			Grade % Length
			mi
			Up/Down %
Calculate Flow Adjustments			
f _p	1.00	E _R	2.0
E _T	2.5	f _{HV} = 1/[1+P _T (E _T - 1) + P _R (E _R - 1)]	0.917
Speed Inputs		Calc Speed Adj and FFS	
Lane Width	ft		
Rt-Side Lat. Clearance	ft	f _{LW}	mph
Number of Lanes, N	2	f _{LC}	mph
Total Ramp Density, TRD	ramps/mi	TRD Adjustment	mph
FFS (measured)	70.0	FFS	70.0
Base free-flow Speed, BFFS	mph		
LOS and Performance Measures		Design (N)	
<u>Operational (LOS)</u>		<u>Design (N)</u>	
v _p = (V or DDHV) / (PHF x N x f _{HV} x f _p)		Design LOS	
1915	pc/h/ln	v _p = (V or DDHV) / (PHF x N x f _{HV} x f _p)	
S	64.1	pc/h/ln	
D = v _p / S	29.9	S	
LOS	D	mph	
		D = v _p / S	
		pc/mi/ln	
		Required Number of Lanes, N	
Glossary		Factor Location	
N - Number of lanes	S - Speed	E _R - Exhibits 11-10, 11-12	f _{LW} - Exhibit 11-8
V - Hourly volume	D - Density	E _T - Exhibits 11-10, 11-11, 11-13	f _{LC} - Exhibit 11-9
v _p - Flow rate	FFS - Free-flow speed	f _p - Page 11-18	TRD - Page 11-11
LOS - Level of service	BFFS - Base free-flow speed	LOS, S, FFS, v _p - Exhibits 11-2, 11-3	
DDHV - Directional design hour volume			

BASIC FREEWAY SEGMENTS WORKSHEET			
General Information		Site Information	
Analyst	BAR	Highway/Direction of Travel	I-26
Agency or Company	HNTB North Carolina, PC	From/To	US 64 to Upward Road
Date Performed	7/12/2013	Jurisdiction	Buncombe County
Analysis Time Period	Peak	Analysis Year	2020 No Build
Project Description <i>STIP I4400/I-4700 - I-26 Widening</i>			
<input checked="" type="checkbox"/> Oper.(LOS)		<input type="checkbox"/> Des.(N)	<input type="checkbox"/> Planning Data
Flow Inputs			
Volume, V	3015	veh/h	Peak-Hour Factor, PHF
AADT		veh/day	0.90
Peak-Hr Prop. of AADT, K			%Trucks and Buses, P _T
Peak-Hr Direction Prop, D			6
DDHV = AADT x K x D		veh/h	%RVs, P _R
			0
			General Terrain:
			Rolling
			Grade % Length
			mi
			Up/Down %
Calculate Flow Adjustments			
f _p	1.00	E _R	2.0
E _T	2.5	f _{HV} = 1/[1+P _T (E _T - 1) + P _R (E _R - 1)]	0.917
Speed Inputs		Calc Speed Adj and FFS	
Lane Width	ft		
Rt-Side Lat. Clearance	ft	f _{LW}	mph
Number of Lanes, N	2	f _{LC}	mph
Total Ramp Density, TRD	ramps/mi	TRD Adjustment	mph
FFS (measured)	70.0	FFS	70.0
Base free-flow Speed, BFFS	mph		mph
LOS and Performance Measures		Design (N)	
<u>Operational (LOS)</u>		<u>Design (N)</u>	
v _p = (V or DDHV) / (PHF x N x f _{HV} x f _p)		Design LOS	
1826	pc/h/ln	v _p = (V or DDHV) / (PHF x N x f _{HV} x f _p)	
S	65.5	mph	pc/h/ln
D = v _p / S	27.9	S	mph
LOS	D	D = v _p / S	pc/mi/ln
		Required Number of Lanes, N	
Glossary		Factor Location	
N - Number of lanes	S - Speed	E _R - Exhibits 11-10, 11-12	f _{LW} - Exhibit 11-8
V - Hourly volume	D - Density	E _T - Exhibits 11-10, 11-11, 11-13	f _{LC} - Exhibit 11-9
v _p - Flow rate	FFS - Free-flow speed	f _p - Page 11-18	TRD - Page 11-11
LOS - Level of service	BFFS - Base free-flow speed	LOS, S, FFS, v _p - Exhibits 11-2, 11-3	
DDHV - Directional design hour volume			

BASIC FREEWAY SEGMENTS WORKSHEET			
General Information		Site Information	
Analyst	BAR	Highway/Direction of Travel I-26	
Agency or Company	HNTB North Carolina, PC	From/To	I-40 to NC 191
Date Performed	7/12/2013	Jurisdiction	Buncombe County
Analysis Time Period	Peak	Analysis Year	2025 No Build
Project Description STIP I4400/I-4700 - I-26 Widening			
<input checked="" type="checkbox"/> Oper.(LOS)		<input type="checkbox"/> Des.(N)	
<input type="checkbox"/> Planning Data			
Flow Inputs			
Volume, V	4666	veh/h	Peak-Hour Factor, PHF 0.90
AADT		veh/day	%Trucks and Buses, P _T 6
Peak-Hr Prop. of AADT, K			%RVs, P _R 0
Peak-Hr Direction Prop, D			General Terrain: Rolling
DDHV = AADT x K x D		veh/h	Grade % Length mi
			Up/Down %
Calculate Flow Adjustments			
f _p	1.00	E _R	2.0
E _T	2.5	f _{HV} = 1/[1+P _T (E _T - 1) + P _R (E _R - 1)] 0.917	
Speed Inputs		Calc Speed Adj and FFS	
Lane Width	ft		
Rt-Side Lat. Clearance	ft	f _{LW}	mph
Number of Lanes, N	2	f _{LC}	mph
Total Ramp Density, TRD	ramps/mi	TRD Adjustment	mph
FFS (measured)	65.0	FFS	65.0
Base free-flow Speed, BFFS	mph		mph
LOS and Performance Measures		Design (N)	
<u>Operational (LOS)</u>		<u>Design (N)</u>	
v _p = (V or DDHV) / (PHF x N x f _{HV} x f _p)	2826	pc/h/ln	Design LOS
S	36.2	mph	v _p = (V or DDHV) / (PHF x N x f _{HV} x f _p)
D = v _p / S	78.1	pc/mi/ln	pc/h/ln
LOS	F		S
			mph
			D = v _p / S
			pc/mi/ln
			Required Number of Lanes, N
Glossary		Factor Location	
N - Number of lanes	S - Speed	E _R - Exhibits 11-10, 11-12	f _{LW} - Exhibit 11-8
V - Hourly volume	D - Density	E _T - Exhibits 11-10, 11-11, 11-13	f _{LC} - Exhibit 11-9
v _p - Flow rate	FFS - Free-flow speed	f _p - Page 11-18	TRD - Page 11-11
LOS - Level of service	BFFS - Base free-flow speed	LOS, S, FFS, v _p - Exhibits 11-2, 11-3	
DDHV - Directional design hour volume			

BASIC FREEWAY SEGMENTS WORKSHEET			
General Information		Site Information	
Analyst	BAR	Highway/Direction of Travel I-26	
Agency or Company	HNTB North Carolina, PC	From/To	NC 146 to NC 280
Date Performed	7/12/2013	Jurisdiction	Buncombe County
Analysis Time Period	Peak	Analysis Year	2025 No Build
Project Description STIP I4400/I-4700 - I-26 Widening			
<input checked="" type="checkbox"/> Oper.(LOS)		<input type="checkbox"/> Des.(N)	
<input type="checkbox"/> Planning Data			
Flow Inputs			
Volume, V	4198	veh/h	Peak-Hour Factor, PHF 0.90
AADT		veh/day	%Trucks and Buses, P _T 5
Peak-Hr Prop. of AADT, K			%RVs, P _R 0
Peak-Hr Direction Prop, D			General Terrain: Rolling
DDHV = AADT x K x D		veh/h	Grade % Length mi
			Up/Down %
Calculate Flow Adjustments			
f _p	1.00	E _R	2.0
E _T	2.5	f _{HV} = 1/[1+P _T (E _T - 1) + P _R (E _R - 1)] 0.930	
Speed Inputs		Calc Speed Adj and FFS	
Lane Width	ft		
Rt-Side Lat. Clearance	ft	f _{LW}	mph
Number of Lanes, N	2	f _{LC}	mph
Total Ramp Density, TRD	ramps/mi	TRD Adjustment	mph
FFS (measured)	65.0	FFS	65.0
Base free-flow Speed, BFFS	mph		mph
LOS and Performance Measures		Design (N)	
<u>Operational (LOS)</u>		<u>Design (N)</u>	
v _p = (V or DDHV) / (PHF x N x f _{HV} x f _p)	2507	pc/h/ln	Design LOS
S	47.6	mph	v _p = (V or DDHV) / (PHF x N x f _{HV} x f _p)
D = v _p / S	52.6	pc/mi/ln	pc/h/ln
LOS	F		S
			mph
			D = v _p / S
			pc/mi/ln
			Required Number of Lanes, N
Glossary		Factor Location	
N - Number of lanes	S - Speed	E _R - Exhibits 11-10, 11-12	f _{LW} - Exhibit 11-8
V - Hourly volume	D - Density	E _T - Exhibits 11-10, 11-11, 11-13	f _{LC} - Exhibit 11-9
v _p - Flow rate	FFS - Free-flow speed	f _p - Page 11-18	TRD - Page 11-11
LOS - Level of service	BFFS - Base free-flow speed	LOS, S, FFS, v _p - Exhibits 11-2, 11-3	
DDHV - Directional design hour volume			

BASIC FREEWAY SEGMENTS WORKSHEET															
General Information		Site Information													
Analyst	BAR	Highway/Direction of Travel I-26													
Agency or Company	HNTB North Carolina, PC	From/To	NC 280 to US 25												
Date Performed	7/12/2013	Jurisdiction	Buncombe County												
Analysis Time Period	Peak	Analysis Year	2025 No Build												
Project Description STIP I4400/I-4700 - I-26 Widening															
<input checked="" type="checkbox"/> Oper.(LOS)		<input type="checkbox"/> Des.(N)													
<input type="checkbox"/> Planning Data															
Flow Inputs															
Volume, V	3698	veh/h	Peak-Hour Factor, PHF 0.90												
AADT		veh/day	%Trucks and Buses, P _T 6												
Peak-Hr Prop. of AADT, K			%RVs, P _R 0												
Peak-Hr Direction Prop, D			General Terrain: Rolling												
DDHV = AADT x K x D		veh/h	Grade % Length mi Up/Down %												
Calculate Flow Adjustments															
f _p	1.00	E _R	2.0												
E _T	2.5	f _{HV} = 1/[1+P _T (E _T - 1) + P _R (E _R - 1)] 0.917													
Speed Inputs		Calc Speed Adj and FFS													
Lane Width	ft	<table style="width:100%; border-collapse: collapse;"> <tr> <td style="padding: 5px;">f_{LW}</td> <td style="padding: 5px;">mph</td> </tr> <tr> <td style="padding: 5px;">f_{LC}</td> <td style="padding: 5px;">mph</td> </tr> <tr> <td style="padding: 5px;">TRD Adjustment</td> <td style="padding: 5px;">mph</td> </tr> <tr> <td style="padding: 5px;">FFS (measured)</td> <td style="padding: 5px;">65.0 mph</td> </tr> <tr> <td style="padding: 5px;">Base free-flow Speed, BFFS</td> <td style="padding: 5px;">mph</td> </tr> <tr> <td style="padding: 5px;">FFS</td> <td style="padding: 5px;">65.0 mph</td> </tr> </table>		f _{LW}	mph	f _{LC}	mph	TRD Adjustment	mph	FFS (measured)	65.0 mph	Base free-flow Speed, BFFS	mph	FFS	65.0 mph
f _{LW}	mph														
f _{LC}	mph														
TRD Adjustment	mph														
FFS (measured)	65.0 mph														
Base free-flow Speed, BFFS	mph														
FFS	65.0 mph														
Rt-Side Lat. Clearance	ft														
Number of Lanes, N	2														
Total Ramp Density, TRD	ramps/mi														
FFS (measured)	65.0 mph														
Base free-flow Speed, BFFS	mph														
LOS and Performance Measures		Design (N)													
<u>Operational (LOS)</u>		<u>Design (N)</u>													
v _p = (V or DDHV) / (PHF x N x f _{HV} x f _p)	2239 pc/h/ln	Design LOS													
S	55.0 mph	v _p = (V or DDHV) / (PHF x N x f _{HV} x f _p)	pc/h/ln												
D = v _p / S	40.7 pc/mi/ln	S	mph												
LOS	E	D = v _p / S	pc/mi/ln												
		Required Number of Lanes, N													
Glossary		Factor Location													
N - Number of lanes	S - Speed	E _R - Exhibits 11-10, 11-12	f _{LW} - Exhibit 11-8												
V - Hourly volume	D - Density	E _T - Exhibits 11-10, 11-11, 11-13	f _{LC} - Exhibit 11-9												
v _p - Flow rate	FFS - Free-flow speed	f _p - Page 11-18	TRD - Page 11-11												
LOS - Level of service speed	BFFS - Base free-flow speed	LOS, S, FFS, v _p - Exhibits 11-2, 11-3													
DDHV - Directional design hour volume															

BASIC FREEWAY SEGMENTS WORKSHEET			
General Information		Site Information	
Analyst	BAR	Highway/Direction of Travel	I-26
Agency or Company	HNTB North Carolina, PC	From/To	US 25 to US 64
Date Performed	7/12/2013	Jurisdiction	Buncombe County
Analysis Time Period	Peak	Analysis Year	2025 No Build
Project Description <i>STIP I4400/I-4700 - I-26 Widening</i>			
<input checked="" type="checkbox"/> Oper.(LOS)		<input type="checkbox"/> Des.(N)	
<input type="checkbox"/> Planning Data			
Flow Inputs			
Volume, V	3358	veh/h	Peak-Hour Factor, PHF
AADT		veh/day	0.90
Peak-Hr Prop. of AADT, K			%Trucks and Buses, P _T
Peak-Hr Direction Prop, D			6
DDHV = AADT x K x D		veh/h	%RVs, P _R
			0
			General Terrain:
			Rolling
			Grade % Length
			mi
			Up/Down %
Calculate Flow Adjustments			
f _p	1.00	E _R	2.0
E _T	2.5	f _{HV} = 1/[1+P _T (E _T - 1) + P _R (E _R - 1)]	
Speed Inputs		Calc Speed Adj and FFS	
Lane Width	ft		
Rt-Side Lat. Clearance	ft	f _{LW}	mph
Number of Lanes, N	2	f _{LC}	mph
Total Ramp Density, TRD	ramps/mi	TRD Adjustment	mph
FFS (measured)	70.0	FFS	70.0
Base free-flow Speed, BFFS	mph		
LOS and Performance Measures		Design (N)	
<u>Operational (LOS)</u>		<u>Design (N)</u>	
v _p = (V or DDHV) / (PHF x N x f _{HV} x f _p)		Design LOS	
2033	pc/h/ln	v _p = (V or DDHV) / (PHF x N x f _{HV} x f _p)	
S	62.0	pc/h/ln	
D = v _p / S	32.8	S	
LOS	D	mph	
		D = v _p / S	
		pc/mi/ln	
		Required Number of Lanes, N	
Glossary		Factor Location	
N - Number of lanes	S - Speed	E _R - Exhibits 11-10, 11-12	f _{LW} - Exhibit 11-8
V - Hourly volume	D - Density	E _T - Exhibits 11-10, 11-11, 11-13	f _{LC} - Exhibit 11-9
v _p - Flow rate	FFS - Free-flow speed	f _p - Page 11-18	TRD - Page 11-11
LOS - Level of service	BFFS - Base free-flow speed	LOS, S, FFS, v _p - Exhibits 11-2, 11-3	
DDHV - Directional design hour volume			

BASIC FREEWAY SEGMENTS WORKSHEET			
General Information		Site Information	
Analyst	BAR	Highway/Direction of Travel	I-26
Agency or Company	HNTB North Carolina, PC	From/To	US 64 to Upward Road
Date Performed	7/12/2013	Jurisdiction	Buncombe County
Analysis Time Period	Peak	Analysis Year	2025 No Build
Project Description <i>STIP I4400/I-4700 - I-26 Widening</i>			
<input checked="" type="checkbox"/> Oper.(LOS)		<input type="checkbox"/> Des.(N)	<input type="checkbox"/> Planning Data
Flow Inputs			
Volume, V	3235	veh/h	Peak-Hour Factor, PHF
AADT		veh/day	0.90
Peak-Hr Prop. of AADT, K			%Trucks and Buses, P _T
Peak-Hr Direction Prop, D			6
DDHV = AADT x K x D		veh/h	%RVs, P _R
			0
			General Terrain:
			Rolling
			Grade % Length
			mi
			Up/Down %
Calculate Flow Adjustments			
f _p	1.00	E _R	2.0
E _T	2.5	f _{HV} = 1/[1+P _T (E _T - 1) + P _R (E _R - 1)]	0.917
Speed Inputs		Calc Speed Adj and FFS	
Lane Width	ft		
Rt-Side Lat. Clearance	ft	f _{LW}	mph
Number of Lanes, N	2	f _{LC}	mph
Total Ramp Density, TRD	ramps/mi	TRD Adjustment	mph
FFS (measured)	70.0	FFS	70.0
Base free-flow Speed, BFFS	mph		mph
LOS and Performance Measures		Design (N)	
<u>Operational (LOS)</u>		<u>Design (N)</u>	
v _p = (V or DDHV) / (PHF x N x f _{HV} x f _p)		Design LOS	
1959	pc/h/ln	v _p = (V or DDHV) / (PHF x N x f _{HV} x f _p)	
S	63.3	pc/h/ln	
D = v _p / S	30.9	S	
LOS	D	mph	
		D = v _p / S	
		pc/mi/ln	
		Required Number of Lanes, N	
Glossary		Factor Location	
N - Number of lanes	S - Speed	E _R - Exhibits 11-10, 11-12	f _{LW} - Exhibit 11-8
V - Hourly volume	D - Density	E _T - Exhibits 11-10, 11-11, 11-13	f _{LC} - Exhibit 11-9
v _p - Flow rate	FFS - Free-flow speed	f _p - Page 11-18	TRD - Page 11-11
LOS - Level of service	BFFS - Base free-flow speed	LOS, S, FFS, v _p - Exhibits 11-2, 11-3	
DDHV - Directional design hour volume			

BASIC FREEWAY SEGMENTS WORKSHEET			
General Information		Site Information	
Analyst	BAR	Highway/Direction of Travel	I-26
Agency or Company	HNTB North Carolina, PC	From/To	I 40 to NC 191
Date Performed	7/12/2013	Jurisdiction	Buncombe County
Analysis Time Period	Peak	Analysis Year	2030 No Build
Project Description <i>STIP I4400/I-4700 - I-26 Widening</i>			
<input checked="" type="checkbox"/> Oper.(LOS)		<input type="checkbox"/> Des.(N)	
<input type="checkbox"/> Planning Data			
Flow Inputs			
Volume, V	4753	veh/h	Peak-Hour Factor, PHF
AADT		veh/day	0.90
Peak-Hr Prop. of AADT, K			%Trucks and Buses, P _T
Peak-Hr Direction Prop, D			6
DDHV = AADT x K x D		veh/h	%RVs, P _R
			0
			General Terrain:
			Rolling
			Grade % Length
			mi
			Up/Down %
Calculate Flow Adjustments			
f _p	1.00	E _R	2.0
E _T	2.5	f _{HV} = 1/[1+P _T (E _T - 1) + P _R (E _R - 1)]	
Speed Inputs		Calc Speed Adj and FFS	
Lane Width	ft		
Rt-Side Lat. Clearance	ft	f _{LW}	mph
Number of Lanes, N	2	f _{LC}	mph
Total Ramp Density, TRD	ramps/mi	TRD Adjustment	mph
FFS (measured)	65.0	FFS	65.0
Base free-flow Speed, BFFS	mph		mph
LOS and Performance Measures		Design (N)	
<u>Operational (LOS)</u>		<u>Design (N)</u>	
v _p = (V or DDHV) / (PHF x N x f _{HV})		Design LOS	
2878	pc/h/ln	v _p = (V or DDHV) / (PHF x N x f _{HV})	
x f _p)		pc/h/ln	
S	34.0	x f _p)	
S	mph	S	mph
D = v _p / S	84.6	D = v _p / S	pc/mi/ln
84.6	pc/mi/ln	Required Number of Lanes, N	
LOS	F		
Glossary		Factor Location	
N - Number of lanes	S - Speed	E _R - Exhibits 11-10, 11-12	f _{LW} - Exhibit 11-8
V - Hourly volume	D - Density	E _T - Exhibits 11-10, 11-11, 11-13	f _{LC} - Exhibit 11-9
v _p - Flow rate	FFS - Free-flow speed	f _p - Page 11-18	TRD - Page 11-11
LOS - Level of service	BFFS - Base free-flow speed	LOS, S, FFS, v _p - Exhibits 11-2, 11-3	
DDHV - Directional design hour volume			

BASIC FREEWAY SEGMENTS WORKSHEET			
General Information		Site Information	
Analyst	BAR	Highway/Direction of Travel	I-26
Agency or Company	HNTB North Carolina, PC	From/To	NC 146 to NC 280
Date Performed	7/12/2013	Jurisdiction	Buncombe County
Analysis Time Period	Peak	Analysis Year	2030 No Build
Project Description <i>STIP I4400/I-4700 - I-26 Widening</i>			
<input checked="" type="checkbox"/> Oper.(LOS)		<input type="checkbox"/> Des.(N)	<input type="checkbox"/> Planning Data
Flow Inputs			
Volume, V	4309	veh/h	Peak-Hour Factor, PHF
AADT		veh/day	0.90
Peak-Hr Prop. of AADT, K			%Trucks and Buses, P _T
Peak-Hr Direction Prop, D			5
DDHV = AADT x K x D		veh/h	%RVs, P _R
			0
			General Terrain:
			Rolling
			Grade % Length
			mi
			Up/Down %
Calculate Flow Adjustments			
f _p	1.00	E _R	2.0
E _T	2.5	f _{HV} = 1/[1+P _T (E _T - 1) + P _R (E _R - 1)]	0.930
Speed Inputs		Calc Speed Adj and FFS	
Lane Width	ft		
Rt-Side Lat. Clearance	ft	f _{LW}	mph
Number of Lanes, N	2	f _{LC}	mph
Total Ramp Density, TRD	ramps/mi	TRD Adjustment	mph
FFS (measured)	65.0	FFS	65.0
Base free-flow Speed, BFFS	mph		mph
LOS and Performance Measures		Design (N)	
<u>Operational (LOS)</u>		<u>Design (N)</u>	
v _p = (V or DDHV) / (PHF x N x f _{HV})		Design LOS	
2573	pc/h/ln	v _p = (V or DDHV) / (PHF x N x f _{HV})	
x f _p)		pc/h/ln	
S	45.5	x f _p)	
D = v _p / S	56.6	S	
LOS	F	mph	
		D = v _p / S	
		pc/mi/ln	
		Required Number of Lanes, N	
Glossary		Factor Location	
N - Number of lanes	S - Speed	E _R - Exhibits 11-10, 11-12	f _{LW} - Exhibit 11-8
V - Hourly volume	D - Density	E _T - Exhibits 11-10, 11-11, 11-13	f _{LC} - Exhibit 11-9
v _p - Flow rate	FFS - Free-flow speed	f _p - Page 11-18	TRD - Page 11-11
LOS - Level of service	BFFS - Base free-flow speed	LOS, S, FFS, v _p - Exhibits 11-2, 11-3	
DDHV - Directional design hour volume			

BASIC FREEWAY SEGMENTS WORKSHEET			
General Information		Site Information	
Analyst	BAR	Highway/Direction of Travel I-26	
Agency or Company	HNTB North Carolina, PC	From/To	NC 280 to US 25
Date Performed	7/12/2013	Jurisdiction	Buncombe County
Analysis Time Period	Peak	Analysis Year	2030 No Build
Project Description STIP I4400/I-4700 - I-26 Widening			
<input checked="" type="checkbox"/> Oper.(LOS)		<input type="checkbox"/> Des.(N)	
<input type="checkbox"/> Planning Data			
Flow Inputs			
Volume, V	3920	veh/h	Peak-Hour Factor, PHF 0.90
AADT		veh/day	%Trucks and Buses, P _T 6
Peak-Hr Prop. of AADT, K			%RVs, P _R 0
Peak-Hr Direction Prop, D			General Terrain: Rolling
DDHV = AADT x K x D		veh/h	Grade % Length mi
			Up/Down %
Calculate Flow Adjustments			
f _p	1.00	E _R	2.0
E _T	2.5	f _{HV} = 1/[1+P _T (E _T - 1) + P _R (E _R - 1)] 0.917	
Speed Inputs		Calc Speed Adj and FFS	
Lane Width	ft		
Rt-Side Lat. Clearance	ft	f _{LW}	mph
Number of Lanes, N	2	f _{LC}	mph
Total Ramp Density, TRD	ramps/mi	TRD Adjustment	mph
FFS (measured)	65.0	FFS	65.0
Base free-flow Speed, BFFS	mph		mph
LOS and Performance Measures		Design (N)	
<u>Operational (LOS)</u>		<u>Design (N)</u>	
v _p = (V or DDHV) / (PHF x N x f _{HV} x f _p)	2374 pc/h/ln	Design LOS	
S	51.5 mph	v _p = (V or DDHV) / (PHF x N x f _{HV} x f _p)	pc/h/ln
D = v _p / S	46.1 pc/mi/ln	S	mph
LOS	F	D = v _p / S	pc/mi/ln
		Required Number of Lanes, N	
Glossary		Factor Location	
N - Number of lanes	S - Speed	E _R - Exhibits 11-10, 11-12	f _{LW} - Exhibit 11-8
V - Hourly volume	D - Density	E _T - Exhibits 11-10, 11-11, 11-13	f _{LC} - Exhibit 11-9
v _p - Flow rate	FFS - Free-flow speed	f _p - Page 11-18	TRD - Page 11-11
LOS - Level of service	BFFS - Base free-flow speed	LOS, S, FFS, v _p - Exhibits 11-2, 11-3	
DDHV - Directional design hour volume			

BASIC FREEWAY SEGMENTS WORKSHEET			
General Information		Site Information	
Analyst	BAR	Highway/Direction of Travel	I-26
Agency or Company	HNTB North Carolina, PC	From/To	US 25 to US 64
Date Performed	7/12/2013	Jurisdiction	Buncombe County
Analysis Time Period	Peak	Analysis Year	2030 No Build
Project Description <i>STIP I4400/I-4700 - I-26 Widening</i>			
<input checked="" type="checkbox"/> Oper.(LOS)		<input type="checkbox"/> Des.(N)	
<input type="checkbox"/> Planning Data			
Flow Inputs			
Volume, V	3554	veh/h	Peak-Hour Factor, PHF
AADT		veh/day	0.90
Peak-Hr Prop. of AADT, K			%Trucks and Buses, P _T
Peak-Hr Direction Prop, D			6
DDHV = AADT x K x D		veh/h	%RVs, P _R
			0
			General Terrain:
			Rolling
			Grade % Length
			mi
			Up/Down %
Calculate Flow Adjustments			
f _p	1.00	E _R	2.0
E _T	2.5	f _{HV} = 1/[1+P _T (E _T - 1) + P _R (E _R - 1)]	
Speed Inputs		Calc Speed Adj and FFS	
Lane Width	ft		
Rt-Side Lat. Clearance	ft	f _{LW}	mph
Number of Lanes, N	2	f _{LC}	mph
Total Ramp Density, TRD	ramps/mi	TRD Adjustment	mph
FFS (measured)	70.0	FFS	70.0
Base free-flow Speed, BFFS	mph		
LOS and Performance Measures		Design (N)	
<u>Operational (LOS)</u>		<u>Design (N)</u>	
v _p = (V or DDHV) / (PHF x N x f _{HV})		Design LOS	
2152	pc/h/ln	v _p = (V or DDHV) / (PHF x N x f _{HV})	
x f _p)		pc/h/ln	
S	59.5	x f _p)	
S	mph	S	mph
D = v _p / S	36.2	D = v _p / S	pc/mi/ln
36.2	pc/mi/ln	Required Number of Lanes, N	
LOS	E		
Glossary		Factor Location	
N - Number of lanes	S - Speed	E _R - Exhibits 11-10, 11-12	f _{LW} - Exhibit 11-8
V - Hourly volume	D - Density	E _T - Exhibits 11-10, 11-11, 11-13	f _{LC} - Exhibit 11-9
v _p - Flow rate	FFS - Free-flow speed	f _p - Page 11-18	TRD - Page 11-11
LOS - Level of service	BFFS - Base free-flow speed	LOS, S, FFS, v _p - Exhibits 11-2, 11-3	
DDHV - Directional design hour volume			

BASIC FREEWAY SEGMENTS WORKSHEET			
General Information		Site Information	
Analyst	BAR	Highway/Direction of Travel	I-26
Agency or Company	HNTB North Carolina, PC	From/To	US 64 to Upward Road
Date Performed	7/12/2013	Jurisdiction	Buncombe County
Analysis Time Period	Peak	Analysis Year	2030 No Build
Project Description <i>STIP I4400/I-4700 - I-26 Widening</i>			
<input checked="" type="checkbox"/> Oper.(LOS)		<input type="checkbox"/> Des.(N)	
<input type="checkbox"/> Planning Data			
Flow Inputs			
Volume, V	3454	veh/h	Peak-Hour Factor, PHF
AADT		veh/day	0.90
Peak-Hr Prop. of AADT, K			%Trucks and Buses, P _T
Peak-Hr Direction Prop, D			6
DDHV = AADT x K x D		veh/h	%RVs, P _R
			0
			General Terrain:
			Rolling
			Grade % Length
			mi
			Up/Down %
Calculate Flow Adjustments			
f _p	1.00	E _R	2.0
E _T	2.5	f _{HV} = 1/[1+P _T (E _T - 1) + P _R (E _R - 1)]	
Speed Inputs			
Lane Width		Calc Speed Adj and FFS	
Rt-Side Lat. Clearance	ft	f _{LW}	mph
Number of Lanes, N	2	f _{LC}	mph
Total Ramp Density, TRD	ramps/mi	TRD Adjustment	mph
FFS (measured)	70.0	FFS	70.0
Base free-flow Speed, BFFS	mph		mph
LOS and Performance Measures		Design (N)	
<u>Operational (LOS)</u>		<u>Design (N)</u>	
v _p = (V or DDHV) / (PHF x N x f _{HV} x f _p)		Design LOS	
S	60.8	v _p = (V or DDHV) / (PHF x N x f _{HV} x f _p)	pc/h/ln
D = v _p / S	34.4	S	mph
LOS	D	D = v _p / S	pc/mi/ln
		Required Number of Lanes, N	
Glossary		Factor Location	
N - Number of lanes	S - Speed	E _R - Exhibits 11-10, 11-12	f _{LW} - Exhibit 11-8
V - Hourly volume	D - Density	E _T - Exhibits 11-10, 11-11, 11-13	f _{LC} - Exhibit 11-9
v _p - Flow rate	FFS - Free-flow speed	f _p - Page 11-18	TRD - Page 11-11
LOS - Level of service	BFFS - Base free-flow speed	LOS, S, FFS, v _p - Exhibits 11-2, 11-3	
DDHV - Directional design hour volume			

BASIC FREEWAY SEGMENTS WORKSHEET			
General Information		Site Information	
Analyst	BAR	Highway/Direction of Travel	I-26
Agency or Company	HNTB North Carolina, PC	From/To	I-40 to NC 191
Date Performed	7/12/2013	Jurisdiction	Buncombe County
Analysis Time Period	Peak	Analysis Year	2035 No Build
Project Description <i>STIP I4400/I-4700 - I-26 Widening</i>			
<input checked="" type="checkbox"/> Oper.(LOS)		<input type="checkbox"/> Des.(N)	
<input type="checkbox"/> Planning Data			
Flow Inputs			
Volume, V	4840	veh/h	Peak-Hour Factor, PHF
AADT		veh/day	0.90
Peak-Hr Prop. of AADT, K			%Trucks and Buses, P _T
Peak-Hr Direction Prop, D			6
DDHV = AADT x K x D		veh/h	%RVs, P _R
			0
			General Terrain:
			Rolling
			Grade % Length
			mi
			Up/Down %
Calculate Flow Adjustments			
f _p	1.00	E _R	2.0
E _T	2.5	f _{HV} = 1/[1+P _T (E _T - 1) + P _R (E _R - 1)]	
Speed Inputs		Calc Speed Adj and FFS	
Lane Width	ft		
Rt-Side Lat. Clearance	ft	f _{LW}	mph
Number of Lanes, N	2	f _{LC}	mph
Total Ramp Density, TRD	ramps/mi	TRD Adjustment	mph
FFS (measured)	65.0	FFS	65.0
Base free-flow Speed, BFFS	mph		
LOS and Performance Measures		Design (N)	
<u>Operational (LOS)</u>		<u>Design (N)</u>	
v _p = (V or DDHV) / (PHF x N x f _{HV})		Design LOS	
2931	pc/h/ln	v _p = (V or DDHV) / (PHF x N x f _{HV})	
x f _p)		pc/h/ln	
S	31.8	x f _p)	
S	mph	S	mph
D = v _p / S	92.3	D = v _p / S	pc/mi/ln
92.3	pc/mi/ln	Required Number of Lanes, N	
LOS	F		
Glossary		Factor Location	
N - Number of lanes	S - Speed	E _R - Exhibits 11-10, 11-12	f _{LW} - Exhibit 11-8
V - Hourly volume	D - Density	E _T - Exhibits 11-10, 11-11, 11-13	f _{LC} - Exhibit 11-9
v _p - Flow rate	FFS - Free-flow speed	f _p - Page 11-18	TRD - Page 11-11
LOS - Level of service	BFFS - Base free-flow speed	LOS, S, FFS, v _p - Exhibits 11-2, 11-3	
DDHV - Directional design hour volume			

BASIC FREEWAY SEGMENTS WORKSHEET			
General Information		Site Information	
Analyst	BAR	Highway/Direction of Travel I-26	
Agency or Company	HNTB North Carolina, PC	From/To	NC 146 to NC 280
Date Performed	7/12/2013	Jurisdiction	Buncombe County
Analysis Time Period	Peak	Analysis Year	2035 No Build
Project Description STIP I4400/I-4700 - I-26 Widening			
<input checked="" type="checkbox"/> Oper.(LOS)		<input type="checkbox"/> Des.(N)	
<input type="checkbox"/> Planning Data			
Flow Inputs			
Volume, V	4420	veh/h	Peak-Hour Factor, PHF 0.90
AADT		veh/day	%Trucks and Buses, P _T 5
Peak-Hr Prop. of AADT, K			%RVs, P _R 0
Peak-Hr Direction Prop, D			General Terrain: Rolling
DDHV = AADT x K x D		veh/h	Grade % Length mi
			Up/Down %
Calculate Flow Adjustments			
f _p	1.00	E _R	2.0
E _T	2.5	f _{HV} = 1/[1+P _T (E _T - 1) + P _R (E _R - 1)] 0.930	
Speed Inputs		Calc Speed Adj and FFS	
Lane Width	ft		
Rt-Side Lat. Clearance	ft	f _{LW}	mph
Number of Lanes, N	2	f _{LC}	mph
Total Ramp Density, TRD	ramps/mi	TRD Adjustment	mph
FFS (measured)	65.0	FFS	65.0
Base free-flow Speed, BFFS	mph		mph
LOS and Performance Measures		Design (N)	
<u>Operational (LOS)</u>		<u>Design (N)</u>	
v _p = (V or DDHV) / (PHF x N x f _{HV} x f _p)	2640 pc/h/ln	Design LOS	
S	43.2 mph	v _p = (V or DDHV) / (PHF x N x f _{HV} x f _p)	pc/h/ln
D = v _p / S	61.1 pc/mi/ln	S	mph
LOS	F	D = v _p / S	pc/mi/ln
		Required Number of Lanes, N	
Glossary		Factor Location	
N - Number of lanes	S - Speed	E _R - Exhibits 11-10, 11-12	f _{LW} - Exhibit 11-8
V - Hourly volume	D - Density	E _T - Exhibits 11-10, 11-11, 11-13	f _{LC} - Exhibit 11-9
v _p - Flow rate	FFS - Free-flow speed	f _p - Page 11-18	TRD - Page 11-11
LOS - Level of service	BFFS - Base free-flow speed	LOS, S, FFS, v _p - Exhibits 11-2, 11-3	
DDHV - Directional design hour volume			

BASIC FREEWAY SEGMENTS WORKSHEET															
General Information		Site Information													
Analyst	BAR	Highway/Direction of Travel I-26													
Agency or Company	HNTB North Carolina, PC	From/To	NC 280 to US 25												
Date Performed	7/12/2013	Jurisdiction	Buncombe County												
Analysis Time Period	Peak	Analysis Year	2035 No Build												
Project Description STIP I4400/I-4700 - I-26 Widening															
<input checked="" type="checkbox"/> Oper.(LOS)		<input type="checkbox"/> Des.(N)													
<input type="checkbox"/> Planning Data															
Flow Inputs															
Volume, V	4143	veh/h	Peak-Hour Factor, PHF 0.90												
AADT		veh/day	%Trucks and Buses, P _T 6												
Peak-Hr Prop. of AADT, K			%RVs, P _R 0												
Peak-Hr Direction Prop, D			General Terrain: Rolling												
DDHV = AADT x K x D		veh/h	Grade % Length mi												
			Up/Down %												
Calculate Flow Adjustments															
f _p	1.00	E _R	2.0												
E _T	2.5	f _{HV} = 1/[1+P _T (E _T - 1) + P _R (E _R - 1)] 0.917													
Speed Inputs		Calc Speed Adj and FFS													
Lane Width	ft	<table style="width:100%; border-collapse: collapse;"> <tr> <td style="padding: 5px;">f_{LW}</td> <td style="padding: 5px;">mph</td> </tr> <tr> <td style="padding: 5px;">f_{LC}</td> <td style="padding: 5px;">mph</td> </tr> <tr> <td style="padding: 5px;">TRD Adjustment</td> <td style="padding: 5px;">mph</td> </tr> <tr> <td style="padding: 5px;">FFS (measured)</td> <td style="padding: 5px;">65.0 mph</td> </tr> <tr> <td style="padding: 5px;">Base free-flow Speed, BFFS</td> <td style="padding: 5px;">mph</td> </tr> <tr> <td style="padding: 5px;">FFS</td> <td style="padding: 5px;">65.0 mph</td> </tr> </table>		f _{LW}	mph	f _{LC}	mph	TRD Adjustment	mph	FFS (measured)	65.0 mph	Base free-flow Speed, BFFS	mph	FFS	65.0 mph
f _{LW}	mph														
f _{LC}	mph														
TRD Adjustment	mph														
FFS (measured)	65.0 mph														
Base free-flow Speed, BFFS	mph														
FFS	65.0 mph														
Rt-Side Lat. Clearance	ft														
Number of Lanes, N	2														
Total Ramp Density, TRD	ramps/mi														
FFS (measured)	65.0 mph														
Base free-flow Speed, BFFS	mph														
LOS and Performance Measures		Design (N)													
<u>Operational (LOS)</u>		<u>Design (N)</u>													
v _p = (V or DDHV) / (PHF x N x f _{HV} x f _p)	2509 pc/h/ln	Design LOS													
S	47.6 mph	v _p = (V or DDHV) / (PHF x N x f _{HV} x f _p)	pc/h/ln												
D = v _p / S	52.8 pc/mi/ln	S	mph												
LOS	F	D = v _p / S	pc/mi/ln												
		Required Number of Lanes, N													
Glossary		Factor Location													
N - Number of lanes	S - Speed	E _R - Exhibits 11-10, 11-12	f _{LW} - Exhibit 11-8												
V - Hourly volume	D - Density	E _T - Exhibits 11-10, 11-11, 11-13	f _{LC} - Exhibit 11-9												
v _p - Flow rate	FFS - Free-flow speed	f _p - Page 11-18	TRD - Page 11-11												
LOS - Level of service	BFFS - Base free-flow speed	LOS, S, FFS, v _p - Exhibits 11-2, 11-3													
DDHV - Directional design hour volume															

BASIC FREEWAY SEGMENTS WORKSHEET			
General Information		Site Information	
Analyst	BAR	Highway/Direction of Travel	I-26
Agency or Company	HNTB North Carolina, PC	From/To	US 25 to US 64
Date Performed	7/12/2013	Jurisdiction	Buncombe County
Analysis Time Period	Peak	Analysis Year	2035 No Build
Project Description <i>STIP I4400/I-4700 - I-26 Widening</i>			
<input checked="" type="checkbox"/> Oper.(LOS)		<input type="checkbox"/> Des.(N)	
<input type="checkbox"/> Planning Data			
Flow Inputs			
Volume, V	3749	veh/h	Peak-Hour Factor, PHF
AADT		veh/day	0.90
Peak-Hr Prop. of AADT, K			%Trucks and Buses, P _T
Peak-Hr Direction Prop, D			6
DDHV = AADT x K x D		veh/h	%RVs, P _R
			0
			General Terrain:
			Rolling
			Grade % Length
			mi
			Up/Down %
Calculate Flow Adjustments			
f _p	1.00	E _R	2.0
E _T	2.5	f _{HV} = 1/[1+P _T (E _T - 1) + P _R (E _R - 1)]	0.917
Speed Inputs		Calc Speed Adj and FFS	
Lane Width	ft		
Rt-Side Lat. Clearance	ft	f _{LW}	mph
Number of Lanes, N	2	f _{LC}	mph
Total Ramp Density, TRD	ramps/mi	TRD Adjustment	mph
FFS (measured)	70.0	FFS	70.0
Base free-flow Speed, BFFS	mph		mph
LOS and Performance Measures		Design (N)	
<u>Operational (LOS)</u>		<u>Design (N)</u>	
v _p = (V or DDHV) / (PHF x N x f _{HV} x f _p)		Design LOS	
2270	pc/h/ln	v _p = (V or DDHV) / (PHF x N x f _{HV} x f _p)	
S	56.7	mph	pc/h/ln
D = v _p / S	40.0	pc/mi/ln	S
LOS	E	D = v _p / S	pc/mi/ln
		Required Number of Lanes, N	
Glossary		Factor Location	
N - Number of lanes	S - Speed	E _R - Exhibits 11-10, 11-12	f _{LW} - Exhibit 11-8
V - Hourly volume	D - Density	E _T - Exhibits 11-10, 11-11, 11-13	f _{LC} - Exhibit 11-9
v _p - Flow rate	FFS - Free-flow speed	f _p - Page 11-18	TRD - Page 11-11
LOS - Level of service	BFFS - Base free-flow speed	LOS, S, FFS, v _p - Exhibits 11-2, 11-3	
DDHV - Directional design hour volume			

BASIC FREEWAY SEGMENTS WORKSHEET			
General Information		Site Information	
Analyst	BAR	Highway/Direction of Travel	I-26
Agency or Company	HNTB North Carolina, PC	From/To	US 64 to Upward Road
Date Performed	7/12/2013	Jurisdiction	Buncombe County
Analysis Time Period	Peak	Analysis Year	2035 No Build
Project Description <i>STIP I4400/I-4700 - I-26 Widening</i>			
<input checked="" type="checkbox"/> Oper.(LOS)		<input type="checkbox"/> Des.(N)	
<input type="checkbox"/> Planning Data			
Flow Inputs			
Volume, V	3674	veh/h	Peak-Hour Factor, PHF
AADT		veh/day	0.90
Peak-Hr Prop. of AADT, K			%Trucks and Buses, P _T
Peak-Hr Direction Prop, D			6
DDHV = AADT x K x D		veh/h	%RVs, P _R
			0
			General Terrain:
			Rolling
			Grade % Length
			mi
			Up/Down %
Calculate Flow Adjustments			
f _p	1.00	E _R	2.0
E _T	2.5	f _{HV} = 1/[1+P _T (E _T - 1) + P _R (E _R - 1)]	
Speed Inputs		Calc Speed Adj and FFS	
Lane Width	ft		
Rt-Side Lat. Clearance	ft	f _{LW}	mph
Number of Lanes, N	2	f _{LC}	mph
Total Ramp Density, TRD	ramps/mi	TRD Adjustment	mph
FFS (measured)	70.0	FFS	70.0
Base free-flow Speed, BFFS	mph		mph
LOS and Performance Measures		Design (N)	
<u>Operational (LOS)</u>		<u>Design (N)</u>	
v _p = (V or DDHV) / (PHF x N x f _{HV} x f _p)		Design LOS	
2225	pc/h/ln	v _p = (V or DDHV) / (PHF x N x f _{HV} x f _p)	
S	57.8	mph	pc/h/ln
D = v _p / S	38.5	pc/mi/ln	mph
LOS	E	D = v _p / S	
		pc/mi/ln	
		Required Number of Lanes, N	
Glossary		Factor Location	
N - Number of lanes	S - Speed	E _R - Exhibits 11-10, 11-12	f _{LW} - Exhibit 11-8
V - Hourly volume	D - Density	E _T - Exhibits 11-10, 11-11, 11-13	f _{LC} - Exhibit 11-9
v _p - Flow rate	FFS - Free-flow speed	f _p - Page 11-18	TRD - Page 11-11
LOS - Level of service	BFFS - Base free-flow speed	LOS, S, FFS, v _p - Exhibits 11-2, 11-3	
DDHV - Directional design hour volume			

BASIC FREEWAY SEGMENTS WORKSHEET			
General Information		Site Information	
Analyst	BAR	Highway/Direction of Travel	I-26
Agency or Company	HNTB North Carolina, PC	From/To	I 40 to NC 191
Date Performed	7/12/2013	Jurisdiction	Buncombe County
Analysis Time Period	Peak	Analysis Year	2040 No Build
Project Description <i>STIP I4400/I-4700 - I-26 Widening</i>			
<input checked="" type="checkbox"/> Oper.(LOS)		<input type="checkbox"/> Des.(N)	
<input type="checkbox"/> Planning Data			
Flow Inputs			
Volume, V	4927	veh/h	Peak-Hour Factor, PHF
AADT		veh/day	0.90
Peak-Hr Prop. of AADT, K			%Trucks and Buses, P _T
Peak-Hr Direction Prop, D			6
DDHV = AADT x K x D		veh/h	%RVs, P _R
			0
			General Terrain:
			Rolling
			Grade % Length
			mi
			Up/Down %
Calculate Flow Adjustments			
f _p	1.00	E _R	2.0
E _T	2.5	f _{HV} = 1/[1+P _T (E _T - 1) + P _R (E _R - 1)]	
Speed Inputs		Calc Speed Adj and FFS	
Lane Width	ft		
Rt-Side Lat. Clearance	ft	f _{LW}	mph
Number of Lanes, N	2	f _{LC}	mph
Total Ramp Density, TRD	ramps/mi	TRD Adjustment	mph
FFS (measured)	65.0	FFS	65.0
Base free-flow Speed, BFFS	mph		mph
LOS and Performance Measures		Design (N)	
<u>Operational (LOS)</u>		<u>Design (N)</u>	
v _p = (V or DDHV) / (PHF x N x f _{HV})		Design LOS	
2984	pc/h/ln	v _p = (V or DDHV) / (PHF x N x f _{HV})	
x f _p)		pc/h/ln	
S	29.4	x f _p)	
D = v _p / S	101.4	S	mph
LOS	F	D = v _p / S	pc/mi/ln
		Required Number of Lanes, N	
Glossary		Factor Location	
N - Number of lanes	S - Speed	E _R - Exhibits 11-10, 11-12	f _{LW} - Exhibit 11-8
V - Hourly volume	D - Density	E _T - Exhibits 11-10, 11-11, 11-13	f _{LC} - Exhibit 11-9
v _p - Flow rate	FFS - Free-flow speed	f _p - Page 11-18	TRD - Page 11-11
LOS - Level of service	BFFS - Base free-flow speed	LOS, S, FFS, v _p - Exhibits 11-2, 11-3	
DDHV - Directional design hour volume			

BASIC FREEWAY SEGMENTS WORKSHEET			
General Information		Site Information	
Analyst	BAR	Highway/Direction of Travel	I-26
Agency or Company	HNTB North Carolina, PC	From/To	NC 146 to NC 280
Date Performed	7/12/2013	Jurisdiction	Buncombe County
Analysis Time Period	Peak	Analysis Year	2040 No Build
Project Description <i>STIP I4400/I-4700 - I-26 Widening</i>			
<input checked="" type="checkbox"/> Oper.(LOS)		<input type="checkbox"/> Des.(N)	
<input type="checkbox"/> Planning Data			
Flow Inputs			
Volume, V	4531	veh/h	Peak-Hour Factor, PHF
AADT		veh/day	0.90
Peak-Hr Prop. of AADT, K			%Trucks and Buses, P _T
Peak-Hr Direction Prop, D			5
DDHV = AADT x K x D		veh/h	%RVs, P _R
			0
			General Terrain:
			Rolling
			Grade % Length
			mi
			Up/Down %
Calculate Flow Adjustments			
f _p	1.00	E _R	2.0
E _T	2.5	f _{HV} = 1/[1+P _T (E _T - 1) + P _R (E _R - 1)]	0.930
Speed Inputs		Calc Speed Adj and FFS	
Lane Width	ft		
Rt-Side Lat. Clearance	ft	f _{LW}	mph
Number of Lanes, N	2	f _{LC}	mph
Total Ramp Density, TRD	ramps/mi	TRD Adjustment	mph
FFS (measured)	65.0	FFS	65.0
Base free-flow Speed, BFFS	mph		mph
LOS and Performance Measures		Design (N)	
<u>Operational (LOS)</u>		<u>Design (N)</u>	
v _p = (V or DDHV) / (PHF x N x f _{HV})		Design LOS	
2706	pc/h/ln	v _p = (V or DDHV) / (PHF x N x f _{HV})	
x f _p)		pc/h/ln	
S	40.8	x f _p)	
D = v _p / S	66.3	S	
LOS	F	D = v _p / S	
		pc/mi/ln	
		Required Number of Lanes, N	
Glossary		Factor Location	
N - Number of lanes	S - Speed	E _R - Exhibits 11-10, 11-12	f _{LW} - Exhibit 11-8
V - Hourly volume	D - Density	E _T - Exhibits 11-10, 11-11, 11-13	f _{LC} - Exhibit 11-9
v _p - Flow rate	FFS - Free-flow speed	f _p - Page 11-18	TRD - Page 11-11
LOS - Level of service	BFFS - Base free-flow speed	LOS, S, FFS, v _p - Exhibits 11-2, 11-3	
DDHV - Directional design hour volume			

BASIC FREEWAY SEGMENTS WORKSHEET			
General Information		Site Information	
Analyst	BAR	Highway/Direction of Travel I-26	
Agency or Company	HNTB North Carolina, PC	From/To	NC 280 to US 25
Date Performed	7/12/2013	Jurisdiction	Buncombe County
Analysis Time Period	Peak	Analysis Year	2040 No Build
Project Description STIP I4400/I-4700 - I-26 Widening			
<input checked="" type="checkbox"/> Oper.(LOS)		<input type="checkbox"/> Des.(N)	
<input type="checkbox"/> Planning Data			
Flow Inputs			
Volume, V	4366	veh/h	Peak-Hour Factor, PHF 0.90
AADT		veh/day	%Trucks and Buses, P _T 6
Peak-Hr Prop. of AADT, K			%RVs, P _R 0
Peak-Hr Direction Prop, D			General Terrain: Rolling
DDHV = AADT x K x D		veh/h	Grade % Length mi
			Up/Down %
Calculate Flow Adjustments			
f _p	1.00	E _R	2.0
E _T	2.5	f _{HV} = 1/[1+P _T (E _T - 1) + P _R (E _R - 1)] 0.917	
Speed Inputs		Calc Speed Adj and FFS	
Lane Width	ft		
Rt-Side Lat. Clearance	ft	f _{LW}	mph
Number of Lanes, N	2	f _{LC}	mph
Total Ramp Density, TRD	ramps/mi	TRD Adjustment	mph
FFS (measured)	65.0	FFS	65.0
Base free-flow Speed, BFFS	mph		mph
LOS and Performance Measures		Design (N)	
<u>Operational (LOS)</u>		<u>Design (N)</u>	
v _p = (V or DDHV) / (PHF x N x f _{HV} x f _p)	2644	Design LOS	
S	43.1	v _p = (V or DDHV) / (PHF x N x f _{HV} x f _p)	pc/h/ln
D = v _p / S	61.4	S	mph
LOS	F	D = v _p / S	pc/mi/ln
		Required Number of Lanes, N	
Glossary		Factor Location	
N - Number of lanes	S - Speed	E _R - Exhibits 11-10, 11-12	f _{LW} - Exhibit 11-8
V - Hourly volume	D - Density	E _T - Exhibits 11-10, 11-11, 11-13	f _{LC} - Exhibit 11-9
v _p - Flow rate	FFS - Free-flow speed	f _p - Page 11-18	TRD - Page 11-11
LOS - Level of service	BFFS - Base free-flow speed	LOS, S, FFS, v _p - Exhibits 11-2, 11-3	
DDHV - Directional design hour volume			

BASIC FREEWAY SEGMENTS WORKSHEET			
General Information		Site Information	
Analyst	BAR	Highway/Direction of Travel	I-26
Agency or Company	HNTB North Carolina, PC	From/To	US 25 to US 64
Date Performed	7/12/2013	Jurisdiction	Buncombe County
Analysis Time Period	Peak	Analysis Year	2040 No Build
Project Description <i>STIP I4400/I-4700 - I-26 Widening</i>			
<input checked="" type="checkbox"/> Oper.(LOS)		<input type="checkbox"/> Des.(N)	
<input type="checkbox"/> Planning Data			
Flow Inputs			
Volume, V	3945	veh/h	Peak-Hour Factor, PHF
AADT		veh/day	0.90
Peak-Hr Prop. of AADT, K			%Trucks and Buses, P _T
Peak-Hr Direction Prop, D			6
DDHV = AADT x K x D		veh/h	%RVs, P _R
			0
			General Terrain:
			Rolling
			Grade % Length
			mi
			Up/Down %
Calculate Flow Adjustments			
f _p	1.00	E _R	2.0
E _T	2.5	f _{HV} = 1/[1+P _T (E _T - 1) + P _R (E _R - 1)]	
Speed Inputs		Calc Speed Adj and FFS	
Lane Width	ft		
Rt-Side Lat. Clearance	ft	f _{LW}	mph
Number of Lanes, N	2	f _{LC}	mph
Total Ramp Density, TRD	ramps/mi	TRD Adjustment	mph
FFS (measured)	70.0	FFS	70.0
Base free-flow Speed, BFFS	mph		
LOS and Performance Measures		Design (N)	
<u>Operational (LOS)</u>		<u>Design (N)</u>	
v _p = (V or DDHV) / (PHF x N x f _{HV} x f _p)		Design LOS	
2389	pc/h/ln	v _p = (V or DDHV) / (PHF x N x f _{HV} x f _p)	
S	53.6	pc/h/ln	
D = v _p / S	44.6	S	
LOS	E	mph	
		D = v _p / S	
		pc/mi/ln	
		Required Number of Lanes, N	
Glossary		Factor Location	
N - Number of lanes	S - Speed	E _R - Exhibits 11-10, 11-12	f _{LW} - Exhibit 11-8
V - Hourly volume	D - Density	E _T - Exhibits 11-10, 11-11, 11-13	f _{LC} - Exhibit 11-9
v _p - Flow rate	FFS - Free-flow speed	f _p - Page 11-18	TRD - Page 11-11
LOS - Level of service	BFFS - Base free-flow speed	LOS, S, FFS, v _p - Exhibits 11-2, 11-3	
DDHV - Directional design hour volume			

BASIC FREEWAY SEGMENTS WORKSHEET			
General Information		Site Information	
Analyst	BAR	Highway/Direction of Travel	I-26
Agency or Company	HNTB North Carolina, PC	From/To	US 64 to Upward Road
Date Performed	7/12/2013	Jurisdiction	Buncombe County
Analysis Time Period	Peak	Analysis Year	2040 No Build
Project Description <i>STIP I4400/I-4700 - I-26 Widening</i>			
<input checked="" type="checkbox"/> Oper.(LOS)		<input type="checkbox"/> Des.(N)	
<input type="checkbox"/> Planning Data			
Flow Inputs			
Volume, V	3894	veh/h	Peak-Hour Factor, PHF
AADT		veh/day	0.90
Peak-Hr Prop. of AADT, K			%Trucks and Buses, P _T
Peak-Hr Direction Prop, D			6
DDHV = AADT x K x D		veh/h	%RVs, P _R
			0
			General Terrain:
			Rolling
			Grade % Length
			mi
			Up/Down %
Calculate Flow Adjustments			
f _p	1.00	E _R	2.0
E _T	2.5	f _{HV} = 1/[1+P _T (E _T - 1) + P _R (E _R - 1)]	
Speed Inputs		Calc Speed Adj and FFS	
Lane Width	ft		
Rt-Side Lat. Clearance	ft	f _{LW}	mph
Number of Lanes, N	2	f _{LC}	mph
Total Ramp Density, TRD	ramps/mi	TRD Adjustment	mph
FFS (measured)	70.0	FFS	70.0
Base free-flow Speed, BFFS	mph		
LOS and Performance Measures		Design (N)	
<u>Operational (LOS)</u>		<u>Design (N)</u>	
v _p = (V or DDHV) / (PHF x N x f _{HV} x f _p)		Design LOS	
2358	pc/h/ln	v _p = (V or DDHV) / (PHF x N x f _{HV} x f _p)	
S	54.4	mph	pc/h/ln
D = v _p / S	43.3	pc/mi/ln	S
LOS	E	D = v _p / S	
		pc/mi/ln	
		Required Number of Lanes, N	
Glossary		Factor Location	
N - Number of lanes	S - Speed	E _R - Exhibits 11-10, 11-12	f _{LW} - Exhibit 11-8
V - Hourly volume	D - Density	E _T - Exhibits 11-10, 11-11, 11-13	f _{LC} - Exhibit 11-9
v _p - Flow rate	FFS - Free-flow speed	f _p - Page 11-18	TRD - Page 11-11
LOS - Level of service	BFFS - Base free-flow speed	LOS, S, FFS, v _p - Exhibits 11-2, 11-3	
DDHV - Directional design hour volume			

Build 6 Lane

BASIC FREEWAY SEGMENTS WORKSHEET			
General Information		Site Information	
Analyst	BAR	Highway/Direction of Travel I-26	
Agency or Company	HNTB North Carolina, PC	From/To	I-40 to NC 191
Date Performed	7/12/2013	Jurisdiction	Buncombe County
Analysis Time Period	Peak	Analysis Year	2011 Build 6 Lanes
Project Description STIP I4400/I-4700 - I-26 Widening			
<input checked="" type="checkbox"/> Oper.(LOS)		<input type="checkbox"/> Des.(N)	
<input type="checkbox"/> Planning Data			
Flow Inputs			
Volume, V	5020	veh/h	Peak-Hour Factor, PHF 0.90
AADT		veh/day	%Trucks and Buses, P _T 6
Peak-Hr Prop. of AADT, K			%RVs, P _R 0
Peak-Hr Direction Prop, D			General Terrain: Rolling
DDHV = AADT x K x D		veh/h	Grade % Length mi
			Up/Down %
Calculate Flow Adjustments			
f _p	1.00	E _R	2.0
E _T	2.5	f _{HV} = 1/[1+P _T (E _T - 1) + P _R (E _R - 1)] 0.917	
Speed Inputs		Calc Speed Adj and FFS	
Lane Width	ft		
Rt-Side Lat. Clearance	ft	f _{LW}	mph
Number of Lanes, N	3	f _{LC}	mph
Total Ramp Density, TRD	ramps/mi	TRD Adjustment	mph
FFS (measured)	65.0	FFS	65.0
Base free-flow Speed, BFFS	mph		mph
LOS and Performance Measures		Design (N)	
<u>Operational (LOS)</u>		<u>Design (N)</u>	
v _p = (V or DDHV) / (PHF x N x f _{HV})		Design LOS	
2027	pc/h/ln	v _p = (V or DDHV) / (PHF x N x f _{HV})	
x f _p)		pc/h/ln	
S	59.4	x f _p)	
S	mph	S	mph
D = v _p / S	34.1	D = v _p / S	pc/mi/ln
34.1	pc/mi/ln	Required Number of Lanes, N	
LOS	D		
Glossary		Factor Location	
N - Number of lanes	S - Speed	E _R - Exhibits 11-10, 11-12	f _{LW} - Exhibit 11-8
V - Hourly volume	D - Density	E _T - Exhibits 11-10, 11-11, 11-13	f _{LC} - Exhibit 11-9
v _p - Flow rate	FFS - Free-flow speed	f _p - Page 11-18	TRD - Page 11-11
LOS - Level of service	BFFS - Base free-flow speed	LOS, S, FFS, v _p - Exhibits 11-2, 11-3	
DDHV - Directional design hour volume			

BASIC FREEWAY SEGMENTS WORKSHEET			
General Information		Site Information	
Analyst	BAR	Highway/Direction of Travel I-26	
Agency or Company	HNTB North Carolina, PC	From/To	NC 146 to NC 280
Date Performed	7/12/2013	Jurisdiction	Buncombe County
Analysis Time Period	Peak	Analysis Year	2011 Build 6 Lanes
Project Description STIP I4400/I-4700 - I-26 Widening			
<input checked="" type="checkbox"/> Oper.(LOS)		<input type="checkbox"/> Des.(N)	
<input type="checkbox"/> Planning Data			
Flow Inputs			
Volume, V	4496	veh/h	Peak-Hour Factor, PHF 0.90
AADT		veh/day	%Trucks and Buses, P _T 5
Peak-Hr Prop. of AADT, K			%RVs, P _R 0
Peak-Hr Direction Prop, D			General Terrain: Rolling
DDHV = AADT x K x D		veh/h	Grade % Length mi
			Up/Down %
Calculate Flow Adjustments			
f _p	1.00	E _R	2.0
E _T	2.5	f _{HV} = 1/[1+P _T (E _T - 1) + P _R (E _R - 1)] 0.930	
Speed Inputs		Calc Speed Adj and FFS	
Lane Width	ft		
Rt-Side Lat. Clearance	ft	f _{LW}	mph
Number of Lanes, N	3	f _{LC}	mph
Total Ramp Density, TRD	ramps/mi	TRD Adjustment	mph
FFS (measured)	65.0	FFS	65.0
Base free-flow Speed, BFFS	mph		
LOS and Performance Measures		Design (N)	
<u>Operational (LOS)</u>		<u>Design (N)</u>	
v _p = (V or DDHV) / (PHF x N x f _{HV} x f _p)	1790 pc/h/ln	Design LOS	
S	62.8 mph	v _p = (V or DDHV) / (PHF x N x f _{HV} x f _p)	pc/h/ln
D = v _p / S	28.5 pc/mi/ln	S	mph
LOS	D	D = v _p / S	pc/mi/ln
		Required Number of Lanes, N	
Glossary		Factor Location	
N - Number of lanes	S - Speed	E _R - Exhibits 11-10, 11-12	f _{LW} - Exhibit 11-8
V - Hourly volume	D - Density	E _T - Exhibits 11-10, 11-11, 11-13	f _{LC} - Exhibit 11-9
v _p - Flow rate	FFS - Free-flow speed	f _p - Page 11-18	TRD - Page 11-11
LOS - Level of service speed	BFFS - Base free-flow speed	LOS, S, FFS, v _p - Exhibits 11-2, 11-3	
DDHV - Directional design hour volume			

BASIC FREEWAY SEGMENTS WORKSHEET			
General Information		Site Information	
Analyst	BAR	Highway/Direction of Travel I-26	
Agency or Company	HNTB North Carolina, PC	From/To	NC 280 to US 25
Date Performed	7/12/2013	Jurisdiction	Buncombe County
Analysis Time Period	Peak	Analysis Year	2011 Build 6 Lanes
Project Description STIP I4400/I-4700 - I-26 Widening			
<input checked="" type="checkbox"/> Oper.(LOS)		<input type="checkbox"/> Des.(N)	
<input type="checkbox"/> Planning Data			
Flow Inputs			
Volume, V	3415	veh/h	Peak-Hour Factor, PHF 0.90
AADT		veh/day	%Trucks and Buses, P _T 6
Peak-Hr Prop. of AADT, K			%RVs, P _R 0
Peak-Hr Direction Prop, D			General Terrain: Rolling
DDHV = AADT x K x D		veh/h	Grade % Length mi
			Up/Down %
Calculate Flow Adjustments			
f _p	1.00	E _R	2.0
E _T	2.5	f _{HV} = 1/[1+P _T (E _T - 1) + P _R (E _R - 1)] 0.917	
Speed Inputs		Calc Speed Adj and FFS	
Lane Width	ft		
Rt-Side Lat. Clearance	ft	f _{LW}	mph
Number of Lanes, N	3	f _{LC}	mph
Total Ramp Density, TRD	ramps/mi	TRD Adjustment	mph
FFS (measured)	65.0	FFS	65.0
Base free-flow Speed, BFFS	mph		mph
LOS and Performance Measures		Design (N)	
<u>Operational (LOS)</u>		<u>Design (N)</u>	
v _p = (V or DDHV) / (PHF x N x f _{HV})		Design LOS	
1379	pc/h/ln	v _p = (V or DDHV) / (PHF x N x f _{HV})	
x f _p)		pc/h/ln	
S	65.0	x f _p)	
S	mph	S	mph
D = v _p / S	21.2	D = v _p / S	pc/mi/ln
21.2	pc/mi/ln	Required Number of Lanes, N	
LOS	C		
Glossary		Factor Location	
N - Number of lanes	S - Speed	E _R - Exhibits 11-10, 11-12	f _{LW} - Exhibit 11-8
V - Hourly volume	D - Density	E _T - Exhibits 11-10, 11-11, 11-13	f _{LC} - Exhibit 11-9
v _p - Flow rate	FFS - Free-flow speed	f _p - Page 11-18	TRD - Page 11-11
LOS - Level of service	BFFS - Base free-flow speed	LOS, S, FFS, v _p - Exhibits 11-2, 11-3	
DDHV - Directional design hour volume			

BASIC FREEWAY SEGMENTS WORKSHEET			
General Information		Site Information	
Analyst	BAR	Highway/Direction of Travel	I-26
Agency or Company	HNTB North Carolina, PC	From/To	US 25 to US 64
Date Performed	7/12/2013	Jurisdiction	Buncombe County
Analysis Time Period	Peak	Analysis Year	2011 Build 6 Lanes
Project Description <i>STIP I4400/I-4700 - I-26 Widening</i>			
<input checked="" type="checkbox"/> Oper.(LOS)		<input type="checkbox"/> Des.(N)	
<input type="checkbox"/> Planning Data			
Flow Inputs			
Volume, V	3073	veh/h	Peak-Hour Factor, PHF
AADT		veh/day	0.90
Peak-Hr Prop. of AADT, K			%Trucks and Buses, P _T
Peak-Hr Direction Prop, D			6
DDHV = AADT x K x D		veh/h	%RVs, P _R
			0
			General Terrain:
			Rolling
			Grade % Length
			mi
			Up/Down %
Calculate Flow Adjustments			
f _p	1.00	E _R	2.0
E _T	2.5	f _{HV} = 1/[1+P _T (E _T - 1) + P _R (E _R - 1)]	0.917
Speed Inputs		Calc Speed Adj and FFS	
Lane Width	ft		
Rt-Side Lat. Clearance	ft	f _{LW}	mph
Number of Lanes, N	3	f _{LC}	mph
Total Ramp Density, TRD	ramps/mi	TRD Adjustment	mph
FFS (measured)	70.0	FFS	70.0
Base free-flow Speed, BFFS	mph		mph
LOS and Performance Measures		Design (N)	
<u>Operational (LOS)</u>		<u>Design (N)</u>	
v _p = (V or DDHV) / (PHF x N x f _{HV} x f _p)	1241 pc/h/ln	Design LOS	
S	70.0 mph	v _p = (V or DDHV) / (PHF x N x f _{HV} x f _p)	pc/h/ln
D = v _p / S	17.7 pc/mi/ln	S	mph
LOS	B	D = v _p / S	pc/mi/ln
		Required Number of Lanes, N	
Glossary		Factor Location	
N - Number of lanes	S - Speed	E _R - Exhibits 11-10, 11-12	f _{LW} - Exhibit 11-8
V - Hourly volume	D - Density	E _T - Exhibits 11-10, 11-11, 11-13	f _{LC} - Exhibit 11-9
v _p - Flow rate	FFS - Free-flow speed	f _p - Page 11-18	TRD - Page 11-11
LOS - Level of service	BFFS - Base free-flow speed	LOS, S, FFS, v _p - Exhibits 11-2, 11-3	
DDHV - Directional design hour volume			

BASIC FREEWAY SEGMENTS WORKSHEET			
General Information		Site Information	
Analyst	BAR	Highway/Direction of Travel	I-26
Agency or Company	HNTB North Carolina, PC	From/To	US 64 to Upward Road
Date Performed	7/12/2013	Jurisdiction	Buncombe County
Analysis Time Period	Peak	Analysis Year	2011 Build 6 Lanes
Project Description <i>STIP I4400/I-4700 - I-26 Widening</i>			
<input checked="" type="checkbox"/> Oper.(LOS)		<input type="checkbox"/> Des.(N)	
<input type="checkbox"/> Planning Data			
Flow Inputs			
Volume, V	2670	veh/h	Peak-Hour Factor, PHF
AADT		veh/day	0.90
Peak-Hr Prop. of AADT, K			%Trucks and Buses, P _T
Peak-Hr Direction Prop, D			6
DDHV = AADT x K x D		veh/h	%RVs, P _R
			0
			General Terrain:
			Rolling
			Grade % Length
			mi
			Up/Down %
Calculate Flow Adjustments			
f _p	1.00	E _R	2.0
E _T	2.5	f _{HV} = 1/[1+P _T (E _T - 1) + P _R (E _R - 1)]	
Speed Inputs		Calc Speed Adj and FFS	
Lane Width	ft		
Rt-Side Lat. Clearance	ft	f _{LW}	mph
Number of Lanes, N	3	f _{LC}	mph
Total Ramp Density, TRD	ramps/mi	TRD Adjustment	mph
FFS (measured)	70.0	FFS	70.0
Base free-flow Speed, BFFS	mph		
LOS and Performance Measures		Design (N)	
<u>Operational (LOS)</u>		<u>Design (N)</u>	
v _p = (V or DDHV) / (PHF x N x f _{HV} x f _p)		Design LOS	
1078	pc/h/ln	v _p = (V or DDHV) / (PHF x N x f _{HV} x f _p)	
S	70.0	mph	pc/h/ln
D = v _p / S	15.4	pc/mi/ln	S
LOS	B	D = v _p / S	
		pc/mi/ln	
		Required Number of Lanes, N	
Glossary		Factor Location	
N - Number of lanes	S - Speed	E _R - Exhibits 11-10, 11-12	f _{LW} - Exhibit 11-8
V - Hourly volume	D - Density	E _T - Exhibits 11-10, 11-11, 11-13	f _{LC} - Exhibit 11-9
v _p - Flow rate	FFS - Free-flow speed	f _p - Page 11-18	TRD - Page 11-11
LOS - Level of service	BFFS - Base free-flow speed	LOS, S, FFS, v _p - Exhibits 11-2, 11-3	
DDHV - Directional design hour volume			

BASIC FREEWAY SEGMENTS WORKSHEET			
General Information		Site Information	
Analyst	BAR	Highway/Direction of Travel	I-26
Agency or Company	HNTB North Carolina, PC	From/To	I 40 to NC 191
Date Performed	7/12/2013	Jurisdiction	Buncombe County
Analysis Time Period	Peak	Analysis Year	2015 Build 6 Lanes
Project Description <i>STIP I4400/I-4700 - I-26 Widening</i>			
<input checked="" type="checkbox"/> Oper.(LOS)		<input type="checkbox"/> Des.(N)	
<input type="checkbox"/> Planning Data			
Flow Inputs			
Volume, V	5148	veh/h	Peak-Hour Factor, PHF
AADT		veh/day	0.90
Peak-Hr Prop. of AADT, K			%Trucks and Buses, P _T
Peak-Hr Direction Prop, D			6
DDHV = AADT x K x D		veh/h	%RVs, P _R
			0
			General Terrain:
			Rolling
			Grade % Length
			mi
			Up/Down %
Calculate Flow Adjustments			
f _p	1.00	E _R	2.0
E _T	2.5	f _{HV} = 1/[1+P _T (E _T - 1) + P _R (E _R - 1)]	
Speed Inputs		Calc Speed Adj and FFS	
Lane Width	ft		
Rt-Side Lat. Clearance	ft	f _{LW}	mph
Number of Lanes, N	3	f _{LC}	mph
Total Ramp Density, TRD	ramps/mi	TRD Adjustment	mph
FFS (measured)	65.0	FFS	65.0
Base free-flow Speed, BFFS	mph		mph
LOS and Performance Measures		Design (N)	
<u>Operational (LOS)</u>		<u>Design (N)</u>	
v _p = (V or DDHV) / (PHF x N x f _{HV})		Design LOS	
2078	pc/h/ln	v _p = (V or DDHV) / (PHF x N x f _{HV})	
x f _p)		pc/h/ln	
S	58.5	x f _p)	
S	mph	S	mph
D = v _p / S	35.5	D = v _p / S	pc/mi/ln
35.5	pc/mi/ln	Required Number of Lanes, N	
LOS	E		
Glossary		Factor Location	
N - Number of lanes	S - Speed	E _R - Exhibits 11-10, 11-12	f _{LW} - Exhibit 11-8
V - Hourly volume	D - Density	E _T - Exhibits 11-10, 11-11, 11-13	f _{LC} - Exhibit 11-9
v _p - Flow rate	FFS - Free-flow speed	f _p - Page 11-18	TRD - Page 11-11
LOS - Level of service	BFFS - Base free-flow speed	LOS, S, FFS, v _p - Exhibits 11-2, 11-3	
DDHV - Directional design hour volume			

BASIC FREEWAY SEGMENTS WORKSHEET			
General Information		Site Information	
Analyst	BAR	Highway/Direction of Travel I-26	
Agency or Company	HNTB North Carolina, PC	From/To	NC 146 to NC 280
Date Performed	7/12/2013	Jurisdiction	Buncombe County
Analysis Time Period	Peak	Analysis Year	2015 Build 6 Lanes
Project Description STIP I4400/I-4700 - I-26 Widening			
<input checked="" type="checkbox"/> Oper.(LOS)		<input type="checkbox"/> Des.(N)	
<input type="checkbox"/> Planning Data			
Flow Inputs			
Volume, V	4665	veh/h	Peak-Hour Factor, PHF 0.90
AADT		veh/day	%Trucks and Buses, P _T 5
Peak-Hr Prop. of AADT, K			%RVs, P _R 0
Peak-Hr Direction Prop, D			General Terrain: Rolling
DDHV = AADT x K x D		veh/h	Grade % Length mi
			Up/Down %
Calculate Flow Adjustments			
f _p	1.00	E _R	2.0
E _T	2.5	f _{HV} = 1/[1+P _T (E _T - 1) + P _R (E _R - 1)] 0.930	
Speed Inputs		Calc Speed Adj and FFS	
Lane Width	ft		
Rt-Side Lat. Clearance	ft	f _{LW}	mph
Number of Lanes, N	3	f _{LC}	mph
Total Ramp Density, TRD	ramps/mi	TRD Adjustment	mph
FFS (measured)	65.0	FFS	65.0
Base free-flow Speed, BFFS	mph		
LOS and Performance Measures		Design (N)	
<u>Operational (LOS)</u>		<u>Design (N)</u>	
v _p = (V or DDHV) / (PHF x N x f _{HV} x f _p)	1857 pc/h/ln	Design LOS	
S	62.0 mph	v _p = (V or DDHV) / (PHF x N x f _{HV} x f _p)	pc/h/ln
D = v _p / S	29.9 pc/mi/ln	S	mph
LOS	D	D = v _p / S	pc/mi/ln
		Required Number of Lanes, N	
Glossary		Factor Location	
N - Number of lanes	S - Speed	E _R - Exhibits 11-10, 11-12	f _{LW} - Exhibit 11-8
V - Hourly volume	D - Density	E _T - Exhibits 11-10, 11-11, 11-13	f _{LC} - Exhibit 11-9
v _p - Flow rate	FFS - Free-flow speed	f _p - Page 11-18	TRD - Page 11-11
LOS - Level of service	BFFS - Base free-flow speed	LOS, S, FFS, v _p - Exhibits 11-2, 11-3	
DDHV - Directional design hour volume			

BASIC FREEWAY SEGMENTS WORKSHEET			
General Information		Site Information	
Analyst	BAR	Highway/Direction of Travel I-26	
Agency or Company	HNTB North Carolina, PC	From/To	NC 280 to US 25
Date Performed	7/12/2013	Jurisdiction	Buncombe County
Analysis Time Period	Peak	Analysis Year	2015 Build 6 Lanes
Project Description STIP I4400/I-4700 - I-26 Widening			
<input checked="" type="checkbox"/> Oper.(LOS)		<input type="checkbox"/> Des.(N)	
<input type="checkbox"/> Planning Data			
Flow Inputs			
Volume, V	3672	veh/h	Peak-Hour Factor, PHF 0.90
AADT		veh/day	%Trucks and Buses, P _T 6
Peak-Hr Prop. of AADT, K			%RVs, P _R 0
Peak-Hr Direction Prop, D			General Terrain: Rolling
DDHV = AADT x K x D		veh/h	Grade % Length mi
			Up/Down %
Calculate Flow Adjustments			
f _p	1.00	E _R	2.0
E _T	2.5	f _{HV} = 1/[1+P _T (E _T - 1) + P _R (E _R - 1)] 0.917	
Speed Inputs		Calc Speed Adj and FFS	
Lane Width	ft		
Rt-Side Lat. Clearance	ft	f _{LW}	mph
Number of Lanes, N	3	f _{LC}	mph
Total Ramp Density, TRD	ramps/mi	TRD Adjustment	mph
FFS (measured)	65.0	FFS	65.0
Base free-flow Speed, BFFS	mph		mph
LOS and Performance Measures		Design (N)	
<u>Operational (LOS)</u>		<u>Design (N)</u>	
v _p = (V or DDHV) / (PHF x N x f _{HV} x f _p)		Design LOS	
1482	pc/h/ln	v _p = (V or DDHV) / (PHF x N x f _{HV} x f _p)	
S	64.9	mph	pc/h/ln
D = v _p / S	22.8	pc/mi/ln	S
LOS	C	D = v _p / S	
		pc/mi/ln	
		Required Number of Lanes, N	
Glossary		Factor Location	
N - Number of lanes	S - Speed	E _R - Exhibits 11-10, 11-12	f _{LW} - Exhibit 11-8
V - Hourly volume	D - Density	E _T - Exhibits 11-10, 11-11, 11-13	f _{LC} - Exhibit 11-9
v _p - Flow rate	FFS - Free-flow speed	f _p - Page 11-18	TRD - Page 11-11
LOS - Level of service	BFFS - Base free-flow speed	LOS, S, FFS, v _p - Exhibits 11-2, 11-3	
DDHV - Directional design hour volume			

BASIC FREEWAY SEGMENTS WORKSHEET			
General Information		Site Information	
Analyst	BAR	Highway/Direction of Travel	I-26
Agency or Company	HNTB North Carolina, PC	From/To	US 25 to US 64
Date Performed	7/12/2013	Jurisdiction	Buncombe County
Analysis Time Period	Peak	Analysis Year	2015 Build 6 Lanes
Project Description <i>STIP I4400/I-4700 - I-26 Widening</i>			
<input checked="" type="checkbox"/> Oper.(LOS)		<input type="checkbox"/> Des.(N)	
<input type="checkbox"/> Planning Data			
Flow Inputs			
Volume, V	3331	veh/h	Peak-Hour Factor, PHF
AADT		veh/day	0.90
Peak-Hr Prop. of AADT, K			%Trucks and Buses, P _T
Peak-Hr Direction Prop, D			6
DDHV = AADT x K x D		veh/h	%RVs, P _R
			0
			General Terrain:
			Rolling
			Grade % Length
			mi
			Up/Down %
Calculate Flow Adjustments			
f _p	1.00	E _R	2.0
E _T	2.5	f _{HV} = 1/[1+P _T (E _T - 1) + P _R (E _R - 1)]	
Speed Inputs		Calc Speed Adj and FFS	
Lane Width	ft		
Rt-Side Lat. Clearance	ft	f _{LW}	mph
Number of Lanes, N	3	f _{LC}	mph
Total Ramp Density, TRD	ramps/mi	TRD Adjustment	mph
FFS (measured)	70.0	FFS	70.0
Base free-flow Speed, BFFS	mph		
LOS and Performance Measures		Design (N)	
<u>Operational (LOS)</u>		<u>Design (N)</u>	
v _p = (V or DDHV) / (PHF x N x f _{HV} x f _p)		Design LOS	
1345	pc/h/ln	v _p = (V or DDHV) / (PHF x N x f _{HV} x f _p)	
S	69.8	pc/h/ln	
D = v _p / S	19.3	S	
LOS	C	mph	
		D = v _p / S	
		pc/mi/ln	
		Required Number of Lanes, N	
Glossary		Factor Location	
N - Number of lanes	S - Speed	E _R - Exhibits 11-10, 11-12	f _{LW} - Exhibit 11-8
V - Hourly volume	D - Density	E _T - Exhibits 11-10, 11-11, 11-13	f _{LC} - Exhibit 11-9
v _p - Flow rate	FFS - Free-flow speed	f _p - Page 11-18	TRD - Page 11-11
LOS - Level of service	BFFS - Base free-flow speed	LOS, S, FFS, v _p - Exhibits 11-2, 11-3	
DDHV - Directional design hour volume			

BASIC FREEWAY SEGMENTS WORKSHEET			
General Information		Site Information	
Analyst	BAR	Highway/Direction of Travel	I-26
Agency or Company	HNTB North Carolina, PC	From/To	US 64 to Upward Road
Date Performed	7/12/2013	Jurisdiction	Buncombe County
Analysis Time Period	Peak	Analysis Year	2015 Build 6 Lanes
Project Description STIP I4400/I-4700 - I-26 Widening			
<input checked="" type="checkbox"/> Oper.(LOS)		<input type="checkbox"/> Des.(N)	<input type="checkbox"/> Planning Data
Flow Inputs			
Volume, V	2927	veh/h	Peak-Hour Factor, PHF 0.90
AADT		veh/day	%Trucks and Buses, P _T 6
Peak-Hr Prop. of AADT, K			%RVs, P _R 0
Peak-Hr Direction Prop, D			General Terrain: Rolling
DDHV = AADT x K x D		veh/h	Grade % Length mi
			Up/Down %
Calculate Flow Adjustments			
f _p	1.00	E _R	2.0
E _T	2.5	f _{HV} = 1/[1+P _T (E _T - 1) + P _R (E _R - 1)]	0.917
Speed Inputs		Calc Speed Adj and FFS	
Lane Width		ft	
Rt-Side Lat. Clearance		ft	f _{LW} mph
Number of Lanes, N	3		f _{LC} mph
Total Ramp Density, TRD		ramps/mi	TRD Adjustment mph
FFS (measured)	70.0	mph	FFS 70.0 mph
Base free-flow Speed, BFFS		mph	
LOS and Performance Measures		Design (N)	
<u>Operational (LOS)</u>		<u>Design (N)</u>	
v _p = (V or DDHV) / (PHF x N x f _{HV} x f _p)	1182	pc/h/ln	v _p = (V or DDHV) / (PHF x N x f _{HV} x f _p)
S	70.0	mph	S
D = v _p / S	16.9	pc/mi/ln	D = v _p / S
LOS	B		Required Number of Lanes, N
Glossary		Factor Location	
N - Number of lanes	S - Speed	E _R - Exhibits 11-10, 11-12	f _{LW} - Exhibit 11-8
V - Hourly volume	D - Density	E _T - Exhibits 11-10, 11-11, 11-13	f _{LC} - Exhibit 11-9
v _p - Flow rate	FFS - Free-flow speed	f _p - Page 11-18	TRD - Page 11-11
LOS - Level of service	BFFS - Base free-flow speed	LOS, S, FFS, v _p - Exhibits 11-2, 11-3	
DDHV - Directional design hour volume			

BASIC FREEWAY SEGMENTS WORKSHEET			
General Information		Site Information	
Analyst	BAR	Highway/Direction of Travel	I-26
Agency or Company	HNTB North Carolina, PC	From/To	I 40 to NC 191
Date Performed	7/12/2013	Jurisdiction	Buncombe County
Analysis Time Period	Peak	Analysis Year	2020 Build 6 Lanes
Project Description <i>STIP I4400/I-4700 - I-26 Widening</i>			
<input checked="" type="checkbox"/> Oper.(LOS)		<input type="checkbox"/> Des.(N)	
<input type="checkbox"/> Planning Data			
Flow Inputs			
Volume, V	5308	veh/h	Peak-Hour Factor, PHF
AADT		veh/day	0.90
Peak-Hr Prop. of AADT, K			%Trucks and Buses, P _T
Peak-Hr Direction Prop, D			6
DDHV = AADT x K x D		veh/h	%RVs, P _R
			0
			General Terrain:
			Rolling
			Grade % Length
			mi
			Up/Down %
Calculate Flow Adjustments			
f _p	1.00	E _R	2.0
E _T	2.5	f _{HV} = 1/[1+P _T (E _T - 1) + P _R (E _R - 1)]	
Speed Inputs		Calc Speed Adj and FFS	
Lane Width	ft		
Rt-Side Lat. Clearance	ft	f _{LW}	mph
Number of Lanes, N	3	f _{LC}	mph
Total Ramp Density, TRD	ramps/mi	TRD Adjustment	mph
FFS (measured)	65.0	FFS	65.0
Base free-flow Speed, BFFS	mph		mph
LOS and Performance Measures		Design (N)	
<u>Operational (LOS)</u>		<u>Design (N)</u>	
v _p = (V or DDHV) / (PHF x N x f _{HV})		Design LOS	
2143	pc/h/ln	v _p = (V or DDHV) / (PHF x N x f _{HV})	
x f _p)		pc/h/ln	
S	57.2	x f _p)	
S	mph	S	mph
D = v _p / S	37.5	D = v _p / S	pc/mi/ln
pc/mi/ln		Required Number of Lanes, N	
LOS	E		
Glossary		Factor Location	
N - Number of lanes	S - Speed	E _R - Exhibits 11-10, 11-12	f _{LW} - Exhibit 11-8
V - Hourly volume	D - Density	E _T - Exhibits 11-10, 11-11, 11-13	f _{LC} - Exhibit 11-9
v _p - Flow rate	FFS - Free-flow speed	f _p - Page 11-18	TRD - Page 11-11
LOS - Level of service	BFFS - Base free-flow speed	LOS, S, FFS, v _p - Exhibits 11-2, 11-3	
DDHV - Directional design hour volume			

BASIC FREEWAY SEGMENTS WORKSHEET											
General Information		Site Information									
Analyst	BAR	Highway/Direction of Travel I-26									
Agency or Company	HNTB North Carolina, PC	From/To	NC 146 to NC 280								
Date Performed	7/12/2013	Jurisdiction	Buncombe County								
Analysis Time Period	Peak	Analysis Year	2020 Build 6 Lanes								
Project Description STIP I4400/I-4700 - I-26 Widening											
<input checked="" type="checkbox"/> Oper.(LOS)		<input type="checkbox"/> Des.(N)									
<input type="checkbox"/> Planning Data											
Flow Inputs											
Volume, V	4877	veh/h	Peak-Hour Factor, PHF 0.90								
AADT		veh/day	%Trucks and Buses, P _T 5								
Peak-Hr Prop. of AADT, K			%RVs, P _R 0								
Peak-Hr Direction Prop, D			General Terrain: Rolling								
DDHV = AADT x K x D		veh/h	Grade % Length mi								
			Up/Down %								
Calculate Flow Adjustments											
f _p	1.00	E _R	2.0								
E _T	2.5	f _{HV} = 1/[1+P _T (E _T - 1) + P _R (E _R - 1)] 0.930									
Speed Inputs		Calc Speed Adj and FFS									
Lane Width	ft	<table style="width:100%; border-collapse: collapse;"> <tr> <td style="padding: 5px;">f_{LW}</td> <td style="padding: 5px;">mph</td> </tr> <tr> <td style="padding: 5px;">f_{LC}</td> <td style="padding: 5px;">mph</td> </tr> <tr> <td style="padding: 5px;">TRD Adjustment</td> <td style="padding: 5px;">mph</td> </tr> <tr> <td style="padding: 5px;">FFS</td> <td style="padding: 5px;">65.0 mph</td> </tr> </table>		f _{LW}	mph	f _{LC}	mph	TRD Adjustment	mph	FFS	65.0 mph
f _{LW}	mph										
f _{LC}	mph										
TRD Adjustment	mph										
FFS	65.0 mph										
Rt-Side Lat. Clearance	ft										
Number of Lanes, N	3										
Total Ramp Density, TRD	ramps/mi										
FFS (measured)	65.0 mph										
Base free-flow Speed, BFFS	mph										
LOS and Performance Measures		Design (N)									
<u>Operational (LOS)</u>		<u>Design (N)</u>									
v _p = (V or DDHV) / (PHF x N x f _{HV} x f _p)	1942 pc/h/ln	Design LOS									
S	60.8 mph	v _p = (V or DDHV) / (PHF x N x f _{HV} x f _p)	pc/h/ln								
D = v _p / S	31.9 pc/mi/ln	S	mph								
LOS	D	D = v _p / S	pc/mi/ln								
		Required Number of Lanes, N									
Glossary		Factor Location									
N - Number of lanes	S - Speed	E _R - Exhibits 11-10, 11-12	f _{LW} - Exhibit 11-8								
V - Hourly volume	D - Density	E _T - Exhibits 11-10, 11-11, 11-13	f _{LC} - Exhibit 11-9								
v _p - Flow rate	FFS - Free-flow speed	f _p - Page 11-18	TRD - Page 11-11								
LOS - Level of service	BFFS - Base free-flow speed	LOS, S, FFS, v _p - Exhibits 11-2, 11-3									
DDHV - Directional design hour volume											

BASIC FREEWAY SEGMENTS WORKSHEET			
General Information		Site Information	
Analyst	BAR	Highway/Direction of Travel I-26	
Agency or Company	HNTB North Carolina, PC	From/To	NC 280 to US 25
Date Performed	7/12/2013	Jurisdiction	Buncombe County
Analysis Time Period	Peak	Analysis Year	2020 Build 6 Lanes
Project Description STIP I4400/I-4700 - I-26 Widening			
<input checked="" type="checkbox"/> Oper.(LOS)		<input type="checkbox"/> Des.(N)	
<input type="checkbox"/> Planning Data			
Flow Inputs			
Volume, V	3992	veh/h	Peak-Hour Factor, PHF 0.90
AADT		veh/day	%Trucks and Buses, P _T 6
Peak-Hr Prop. of AADT, K			%RVs, P _R 0
Peak-Hr Direction Prop, D			General Terrain: Rolling
DDHV = AADT x K x D		veh/h	Grade % Length mi
			Up/Down %
Calculate Flow Adjustments			
f _p	1.00	E _R	2.0
E _T	2.5	f _{HV} = 1/[1+P _T (E _T - 1) + P _R (E _R - 1)] 0.917	
Speed Inputs		Calc Speed Adj and FFS	
Lane Width	ft		
Rt-Side Lat. Clearance	ft	f _{LW}	mph
Number of Lanes, N	3	f _{LC}	mph
Total Ramp Density, TRD	ramps/mi	TRD Adjustment	mph
FFS (measured)	65.0	FFS	65.0
Base free-flow Speed, BFFS	mph		
LOS and Performance Measures		Design (N)	
<u>Operational (LOS)</u>		<u>Design (N)</u>	
v _p = (V or DDHV) / (PHF x N x f _{HV} x f _p)	1612 pc/h/ln	Design LOS	
S	64.4 mph	v _p = (V or DDHV) / (PHF x N x f _{HV} x f _p)	pc/h/ln
D = v _p / S	25.0 pc/mi/ln	S	mph
LOS	C	D = v _p / S	pc/mi/ln
		Required Number of Lanes, N	
Glossary		Factor Location	
N - Number of lanes	S - Speed	E _R - Exhibits 11-10, 11-12	f _{LW} - Exhibit 11-8
V - Hourly volume	D - Density	E _T - Exhibits 11-10, 11-11, 11-13	f _{LC} - Exhibit 11-9
v _p - Flow rate	FFS - Free-flow speed	f _p - Page 11-18	TRD - Page 11-11
LOS - Level of service	BFFS - Base free-flow speed	LOS, S, FFS, v _p - Exhibits 11-2, 11-3	
DDHV - Directional design hour volume			

BASIC FREEWAY SEGMENTS WORKSHEET			
General Information		Site Information	
Analyst	BAR	Highway/Direction of Travel	I-26
Agency or Company	HNTB North Carolina, PC	From/To	US 25 to US 64
Date Performed	7/12/2013	Jurisdiction	Buncombe County
Analysis Time Period	Peak	Analysis Year	2020 Build 6 Lanes
Project Description <i>STIP I4400/I-4700 - I-26 Widening</i>			
<input checked="" type="checkbox"/> Oper.(LOS)		<input type="checkbox"/> Des.(N)	
<input type="checkbox"/> Planning Data			
Flow Inputs			
Volume, V	3654	veh/h	Peak-Hour Factor, PHF
AADT		veh/day	0.90
Peak-Hr Prop. of AADT, K			%Trucks and Buses, P _T
Peak-Hr Direction Prop, D			6
DDHV = AADT x K x D		veh/h	%RVs, P _R
			0
			General Terrain:
			Rolling
			Grade % Length
			mi
			Up/Down %
Calculate Flow Adjustments			
f _p	1.00	E _R	2.0
E _T	2.5	f _{HV} = 1/[1+P _T (E _T - 1) + P _R (E _R - 1)]	
Speed Inputs		Calc Speed Adj and FFS	
Lane Width	ft		
Rt-Side Lat. Clearance	ft	f _{LW}	mph
Number of Lanes, N	3	f _{LC}	mph
Total Ramp Density, TRD	ramps/mi	TRD Adjustment	mph
FFS (measured)	70.0	FFS	70.0
Base free-flow Speed, BFFS	mph		
LOS and Performance Measures		Design (N)	
<u>Operational (LOS)</u>		<u>Design (N)</u>	
v _p = (V or DDHV) / (PHF x N x f _{HV} x f _p)		Design LOS	
1475	pc/h/ln	v _p = (V or DDHV) / (PHF x N x f _{HV} x f _p)	
S	69.1	pc/h/ln	
D = v _p / S	21.3	S	
LOS	C	mph	
		D = v _p / S	
		pc/mi/ln	
		Required Number of Lanes, N	
Glossary		Factor Location	
N - Number of lanes	S - Speed	E _R - Exhibits 11-10, 11-12	f _{LW} - Exhibit 11-8
V - Hourly volume	D - Density	E _T - Exhibits 11-10, 11-11, 11-13	f _{LC} - Exhibit 11-9
v _p - Flow rate	FFS - Free-flow speed	f _p - Page 11-18	TRD - Page 11-11
LOS - Level of service	BFFS - Base free-flow speed	LOS, S, FFS, v _p - Exhibits 11-2, 11-3	
DDHV - Directional design hour volume			

BASIC FREEWAY SEGMENTS WORKSHEET			
General Information		Site Information	
Analyst	BAR	Highway/Direction of Travel	I-26
Agency or Company	HNTB North Carolina, PC	From/To	US 64 to Upward Road
Date Performed	7/12/2013	Jurisdiction	Buncombe County
Analysis Time Period	Peak	Analysis Year	2020 Build 6 Lanes
Project Description <i>STIP I4400/I-4700 - I-26 Widening</i>			
<input checked="" type="checkbox"/> Oper.(LOS)		<input type="checkbox"/> Des.(N)	
<input type="checkbox"/> Planning Data			
Flow Inputs			
Volume, V	3249	veh/h	Peak-Hour Factor, PHF
AADT		veh/day	0.90
Peak-Hr Prop. of AADT, K			%Trucks and Buses, P _T
Peak-Hr Direction Prop, D			6
DDHV = AADT x K x D		veh/h	%RVs, P _R
			0
			General Terrain:
			Rolling
			Grade % Length
			mi
			Up/Down %
Calculate Flow Adjustments			
f _p	1.00	E _R	2.0
E _T	2.5	f _{HV} = 1/[1+P _T (E _T - 1) + P _R (E _R - 1)]	
Speed Inputs		Calc Speed Adj and FFS	
Lane Width	ft		
Rt-Side Lat. Clearance	ft	f _{LW}	mph
Number of Lanes, N	3	f _{LC}	mph
Total Ramp Density, TRD	ramps/mi	TRD Adjustment	mph
FFS (measured)	70.0	FFS	70.0
Base free-flow Speed, BFFS	mph		
LOS and Performance Measures		Design (N)	
<u>Operational (LOS)</u>		<u>Design (N)</u>	
v _p = (V or DDHV) / (PHF x N x f _{HV} x f _p)		Design LOS	
1312	pc/h/ln	v _p = (V or DDHV) / (PHF x N x f _{HV} x f _p)	
S	69.9	pc/h/ln	
D = v _p / S	18.8	S	
LOS	C	mph	
		D = v _p / S	
		pc/mi/ln	
		Required Number of Lanes, N	
Glossary		Factor Location	
N - Number of lanes	S - Speed	E _R - Exhibits 11-10, 11-12	f _{LW} - Exhibit 11-8
V - Hourly volume	D - Density	E _T - Exhibits 11-10, 11-11, 11-13	f _{LC} - Exhibit 11-9
v _p - Flow rate	FFS - Free-flow speed	f _p - Page 11-18	TRD - Page 11-11
LOS - Level of service	BFFS - Base free-flow speed	LOS, S, FFS, v _p - Exhibits 11-2, 11-3	
DDHV - Directional design hour volume			

BASIC FREEWAY SEGMENTS WORKSHEET			
General Information		Site Information	
Analyst	BAR	Highway/Direction of Travel I-26	
Agency or Company	HNTB North Carolina, PC	From/To	I-40 to NC 191
Date Performed	7/12/2013	Jurisdiction	Buncombe County
Analysis Time Period	Peak	Analysis Year	2025 Build 6 Lanes
Project Description STIP I4400/I-4700 - I-26 Widening			
<input checked="" type="checkbox"/> Oper.(LOS)		<input type="checkbox"/> Des.(N)	
<input type="checkbox"/> Planning Data			
Flow Inputs			
Volume, V	5468	veh/h	Peak-Hour Factor, PHF 0.90
AADT		veh/day	%Trucks and Buses, P _T 6
Peak-Hr Prop. of AADT, K			%RVs, P _R 0
Peak-Hr Direction Prop, D			General Terrain: Rolling
DDHV = AADT x K x D		veh/h	Grade % Length mi
			Up/Down %
Calculate Flow Adjustments			
f _p	1.00	E _R	2.0
E _T	2.5	f _{HV} = 1/[1+P _T (E _T - 1) + P _R (E _R - 1)] 0.917	
Speed Inputs		Calc Speed Adj and FFS	
Lane Width	ft		
Rt-Side Lat. Clearance	ft	f _{LW}	mph
Number of Lanes, N	3	f _{LC}	mph
Total Ramp Density, TRD	ramps/mi	TRD Adjustment	mph
FFS (measured)	65.0	FFS	65.0
Base free-flow Speed, BFFS	mph		mph
LOS and Performance Measures		Design (N)	
<u>Operational (LOS)</u>		<u>Design (N)</u>	
v _p = (V or DDHV) / (PHF x N x f _{HV} x f _p)	2207	pc/h/ln	
S	55.8	mph	v _p = (V or DDHV) / (PHF x N x f _{HV} x f _p)
D = v _p / S	39.6	pc/mi/ln	pc/h/ln
LOS	E	S	mph
		D = v _p / S	pc/mi/ln
		Required Number of Lanes, N	
Glossary		Factor Location	
N - Number of lanes	S - Speed	E _R - Exhibits 11-10, 11-12	f _{LW} - Exhibit 11-8
V - Hourly volume	D - Density	E _T - Exhibits 11-10, 11-11, 11-13	f _{LC} - Exhibit 11-9
v _p - Flow rate	FFS - Free-flow speed	f _p - Page 11-18	TRD - Page 11-11
LOS - Level of service	BFFS - Base free-flow speed	LOS, S, FFS, v _p - Exhibits 11-2, 11-3	
DDHV - Directional design hour volume			

BASIC FREEWAY SEGMENTS WORKSHEET			
General Information		Site Information	
Analyst	BAR	Highway/Direction of Travel I-26	
Agency or Company	HNTB North Carolina, PC	From/To	NC 146 to NC 280
Date Performed	7/12/2013	Jurisdiction	Buncombe County
Analysis Time Period	Peak	Analysis Year	2025 Build 6 Lanes
Project Description STIP I4400/I-4700 - I-26 Widening			
<input checked="" type="checkbox"/> Oper.(LOS)		<input type="checkbox"/> Des.(N)	
<input type="checkbox"/> Planning Data			
Flow Inputs			
Volume, V	5088	veh/h	Peak-Hour Factor, PHF 0.90
AADT		veh/day	%Trucks and Buses, P _T 5
Peak-Hr Prop. of AADT, K			%RVs, P _R 0
Peak-Hr Direction Prop, D			General Terrain: Rolling
DDHV = AADT x K x D		veh/h	Grade % Length mi
			Up/Down %
Calculate Flow Adjustments			
f _p	1.00	E _R	2.0
E _T	2.5	f _{HV} = 1/[1+P _T (E _T - 1) + P _R (E _R - 1)] 0.930	
Speed Inputs		Calc Speed Adj and FFS	
Lane Width	ft		
Rt-Side Lat. Clearance	ft	f _{LW}	mph
Number of Lanes, N	3	f _{LC}	mph
Total Ramp Density, TRD	ramps/mi	TRD Adjustment	mph
FFS (measured)	65.0	FFS	65.0
Base free-flow Speed, BFFS	mph		mph
LOS and Performance Measures		Design (N)	
<u>Operational (LOS)</u>		<u>Design (N)</u>	
v _p = (V or DDHV) / (PHF x N x f _{HV} x f _p)		Design LOS	
2026	pc/h/ln	v _p = (V or DDHV) / (PHF x N x f _{HV} x f _p)	
S	59.4	mph	pc/h/ln
D = v _p / S	34.1	pc/mi/ln	S
LOS	D	D = v _p / S	
		pc/mi/ln	
		Required Number of Lanes, N	
Glossary		Factor Location	
N - Number of lanes	S - Speed	E _R - Exhibits 11-10, 11-12	f _{LW} - Exhibit 11-8
V - Hourly volume	D - Density	E _T - Exhibits 11-10, 11-11, 11-13	f _{LC} - Exhibit 11-9
v _p - Flow rate	FFS - Free-flow speed	f _p - Page 11-18	TRD - Page 11-11
LOS - Level of service	BFFS - Base free-flow speed	LOS, S, FFS, v _p - Exhibits 11-2, 11-3	
DDHV - Directional design hour volume			

BASIC FREEWAY SEGMENTS WORKSHEET			
General Information		Site Information	
Analyst	BAR	Highway/Direction of Travel	I-26
Agency or Company	HNTB North Carolina, PC	From/To	NC 280 to US 25
Date Performed	7/12/2013	Jurisdiction	Buncombe County
Analysis Time Period	Peak	Analysis Year	2025 Build 6 Lanes
Project Description <i>STIP I4400/I-4700 - I-26 Widening</i>			
<input checked="" type="checkbox"/> Oper.(LOS)		<input type="checkbox"/> Des.(N)	
<input type="checkbox"/> Planning Data			
Flow Inputs			
Volume, V	4313	veh/h	Peak-Hour Factor, PHF
AADT		veh/day	0.90
Peak-Hr Prop. of AADT, K			%Trucks and Buses, P _T
Peak-Hr Direction Prop, D			6
DDHV = AADT x K x D		veh/h	%RVs, P _R
			0
			General Terrain:
			Rolling
			Grade % Length
			mi
			Up/Down %
Calculate Flow Adjustments			
f _p	1.00	E _R	2.0
E _T	2.5	f _{HV} = 1/[1+P _T (E _T - 1) + P _R (E _R - 1)]	
Speed Inputs		Calc Speed Adj and FFS	
Lane Width	ft		
Rt-Side Lat. Clearance	ft	f _{LW}	mph
Number of Lanes, N	3	f _{LC}	mph
Total Ramp Density, TRD	ramps/mi	TRD Adjustment	mph
FFS (measured)	65.0	FFS	65.0
Base free-flow Speed, BFFS	mph		
LOS and Performance Measures		Design (N)	
<u>Operational (LOS)</u>		<u>Design (N)</u>	
v _p = (V or DDHV) / (PHF x N x f _{HV} x f _p)		Design LOS	
1741	pc/h/ln	v _p = (V or DDHV) / (PHF x N x f _{HV} x f _p)	
S	63.4	pc/h/ln	
D = v _p / S	27.5	S	
LOS	D	mph	
		D = v _p / S	
		pc/mi/ln	
		Required Number of Lanes, N	
Glossary		Factor Location	
N - Number of lanes	S - Speed	E _R - Exhibits 11-10, 11-12	f _{LW} - Exhibit 11-8
V - Hourly volume	D - Density	E _T - Exhibits 11-10, 11-11, 11-13	f _{LC} - Exhibit 11-9
v _p - Flow rate	FFS - Free-flow speed	f _p - Page 11-18	TRD - Page 11-11
LOS - Level of service	BFFS - Base free-flow speed	LOS, S, FFS, v _p - Exhibits 11-2, 11-3	
DDHV - Directional design hour volume			

BASIC FREEWAY SEGMENTS WORKSHEET			
General Information		Site Information	
Analyst	BAR	Highway/Direction of Travel	I-26
Agency or Company	HNTB North Carolina, PC	From/To	US 25 to US 64
Date Performed	7/12/2013	Jurisdiction	Buncombe County
Analysis Time Period	Peak	Analysis Year	2025 Build 6 Lanes
Project Description <i>STIP I4400/I-4700 - I-26 Widening</i>			
<input checked="" type="checkbox"/> Oper.(LOS)		<input type="checkbox"/> Des.(N)	
<input type="checkbox"/> Planning Data			
Flow Inputs			
Volume, V	3977	veh/h	Peak-Hour Factor, PHF
AADT		veh/day	0.90
Peak-Hr Prop. of AADT, K			%Trucks and Buses, P _T
Peak-Hr Direction Prop, D			6
DDHV = AADT x K x D		veh/h	%RVs, P _R
			0
			General Terrain:
			Rolling
			Grade % Length
			mi
			Up/Down %
Calculate Flow Adjustments			
f _p	1.00	E _R	2.0
E _T	2.5	f _{HV} = 1/[1+P _T (E _T - 1) + P _R (E _R - 1)]	0.917
Speed Inputs		Calc Speed Adj and FFS	
Lane Width	ft		
Rt-Side Lat. Clearance	ft	f _{LW}	mph
Number of Lanes, N	3	f _{LC}	mph
Total Ramp Density, TRD	ramps/mi	TRD Adjustment	mph
FFS (measured)	70.0	FFS	70.0
Base free-flow Speed, BFFS	mph		mph
LOS and Performance Measures		Design (N)	
<u>Operational (LOS)</u>		<u>Design (N)</u>	
v _p = (V or DDHV) / (PHF x N x f _{HV} x f _p)		Design LOS	
1606	pc/h/ln	v _p = (V or DDHV) / (PHF x N x f _{HV} x f _p)	
S	68.1	mph	pc/h/ln
D = v _p / S	23.6	pc/mi/ln	S
LOS	C		mph
			pc/mi/ln
			D = v _p / S
			pc/mi/ln
			Required Number of Lanes, N
Glossary		Factor Location	
N - Number of lanes	S - Speed	E _R - Exhibits 11-10, 11-12	f _{LW} - Exhibit 11-8
V - Hourly volume	D - Density	E _T - Exhibits 11-10, 11-11, 11-13	f _{LC} - Exhibit 11-9
v _p - Flow rate	FFS - Free-flow speed	f _p - Page 11-18	TRD - Page 11-11
LOS - Level of service	BFFS - Base free-flow speed	LOS, S, FFS, v _p - Exhibits 11-2, 11-3	
DDHV - Directional design hour volume			

BASIC FREEWAY SEGMENTS WORKSHEET			
General Information		Site Information	
Analyst	BAR	Highway/Direction of Travel	I-26
Agency or Company	HNTB North Carolina, PC	From/To	US 64 to Upward Road
Date Performed	7/12/2013	Jurisdiction	Buncombe County
Analysis Time Period	Peak	Analysis Year	2025 Build 6 Lanes
Project Description STIP I4400/I-4700 - I-26 Widening			
<input checked="" type="checkbox"/> Oper.(LOS)		<input type="checkbox"/> Des.(N)	<input type="checkbox"/> Planning Data
Flow Inputs			
Volume, V	3571	veh/h	Peak-Hour Factor, PHF 0.90
AADT		veh/day	%Trucks and Buses, P _T 6
Peak-Hr Prop. of AADT, K			%RVs, P _R 0
Peak-Hr Direction Prop, D			General Terrain: Rolling
DDHV = AADT x K x D		veh/h	Grade % Length mi
			Up/Down %
Calculate Flow Adjustments			
f _p	1.00	E _R	2.0
E _T	2.5	f _{HV} = 1/[1+P _T (E _T - 1) + P _R (E _R - 1)]	0.917
Speed Inputs		Calc Speed Adj and FFS	
Lane Width		ft	
Rt-Side Lat. Clearance		ft	f _{LW} mph
Number of Lanes, N	3		f _{LC} mph
Total Ramp Density, TRD		ramps/mi	TRD Adjustment mph
FFS (measured)	70.0	mph	FFS 70.0 mph
Base free-flow Speed, BFFS		mph	
LOS and Performance Measures		Design (N)	
<u>Operational (LOS)</u>		<u>Design (N)</u>	
v _p = (V or DDHV) / (PHF x N x f _{HV} x f _p)	1442	pc/h/ln	v _p = (V or DDHV) / (PHF x N x f _{HV} x f _p)
S	69.3	mph	S
D = v _p / S	20.8	pc/mi/ln	D = v _p / S
LOS	C		Required Number of Lanes, N
Glossary		Factor Location	
N - Number of lanes	S - Speed	E _R - Exhibits 11-10, 11-12	f _{LW} - Exhibit 11-8
V - Hourly volume	D - Density	E _T - Exhibits 11-10, 11-11, 11-13	f _{LC} - Exhibit 11-9
v _p - Flow rate	FFS - Free-flow speed	f _p - Page 11-18	TRD - Page 11-11
LOS - Level of service	BFFS - Base free-flow speed	LOS, S, FFS, v _p - Exhibits 11-2, 11-3	
DDHV - Directional design hour volume			

BASIC FREEWAY SEGMENTS WORKSHEET			
General Information		Site Information	
Analyst	BAR	Highway/Direction of Travel	I-26
Agency or Company	HNTB North Carolina, PC	From/To	I 40 to NC 191
Date Performed	7/12/2013	Jurisdiction	Buncombe County
Analysis Time Period	Peak	Analysis Year	2030 Build 6 Lanes
Project Description <i>STIP I4400/I-4700 - I-26 Widening</i>			
<input checked="" type="checkbox"/> Oper.(LOS)		<input type="checkbox"/> Des.(N)	
<input type="checkbox"/> Planning Data			
Flow Inputs			
Volume, V	5629	veh/h	Peak-Hour Factor, PHF
AADT		veh/day	0.90
Peak-Hr Prop. of AADT, K			%Trucks and Buses, P _T
Peak-Hr Direction Prop, D			6
DDHV = AADT x K x D		veh/h	%RVs, P _R
			0
			General Terrain:
			Rolling
			Grade % Length
			mi
			Up/Down %
Calculate Flow Adjustments			
f _p	1.00	E _R	2.0
E _T	2.5	f _{HV} = 1/[1+P _T (E _T - 1) + P _R (E _R - 1)]	0.917
Speed Inputs		Calc Speed Adj and FFS	
Lane Width	ft		
Rt-Side Lat. Clearance	ft	f _{LW}	mph
Number of Lanes, N	3	f _{LC}	mph
Total Ramp Density, TRD	ramps/mi	TRD Adjustment	mph
FFS (measured)	65.0	FFS	65.0
Base free-flow Speed, BFFS	mph		mph
LOS and Performance Measures		Design (N)	
<u>Operational (LOS)</u>		<u>Design (N)</u>	
v _p = (V or DDHV) / (PHF x N x f _{HV})		Design LOS	
2272	pc/h/ln	v _p = (V or DDHV) / (PHF x N x f _{HV})	
x f _p)		pc/h/ln	
S	54.2	x f _p)	
S	mph	S	mph
D = v _p / S	41.9	D = v _p / S	pc/mi/ln
41.9	pc/mi/ln	Required Number of Lanes, N	
LOS	E		
Glossary		Factor Location	
N - Number of lanes	S - Speed	E _R - Exhibits 11-10, 11-12	f _{LW} - Exhibit 11-8
V - Hourly volume	D - Density	E _T - Exhibits 11-10, 11-11, 11-13	f _{LC} - Exhibit 11-9
v _p - Flow rate	FFS - Free-flow speed	f _p - Page 11-18	TRD - Page 11-11
LOS - Level of service	BFFS - Base free-flow speed	LOS, S, FFS, v _p - Exhibits 11-2, 11-3	
DDHV - Directional design hour volume			

BASIC FREEWAY SEGMENTS WORKSHEET			
General Information		Site Information	
Analyst	BAR	Highway/Direction of Travel I-26	
Agency or Company	HNTB North Carolina, PC	From/To	NC 146 to NC 280
Date Performed	7/12/2013	Jurisdiction	Buncombe County
Analysis Time Period	Peak	Analysis Year	2030 Build 6 Lanes
Project Description STIP I4400/I-4700 - I-26 Widening			
<input checked="" type="checkbox"/> Oper.(LOS)		<input type="checkbox"/> Des.(N)	
<input type="checkbox"/> Planning Data			
Flow Inputs			
Volume, V	5300	veh/h	Peak-Hour Factor, PHF 0.90
AADT		veh/day	%Trucks and Buses, P _T 5
Peak-Hr Prop. of AADT, K			%RVs, P _R 0
Peak-Hr Direction Prop, D			General Terrain: Rolling
DDHV = AADT x K x D		veh/h	Grade % Length mi
			Up/Down %
Calculate Flow Adjustments			
f _p	1.00	E _R	2.0
E _T	2.5	f _{HV} = 1/[1+P _T (E _T - 1) + P _R (E _R - 1)] 0.930	
Speed Inputs		Calc Speed Adj and FFS	
Lane Width	ft		
Rt-Side Lat. Clearance	ft	f _{LW}	mph
Number of Lanes, N	3	f _{LC}	mph
Total Ramp Density, TRD	ramps/mi	TRD Adjustment	mph
FFS (measured)	65.0	FFS	65.0
Base free-flow Speed, BFFS	mph		mph
LOS and Performance Measures		Design (N)	
<u>Operational (LOS)</u>		<u>Design (N)</u>	
v _p = (V or DDHV) / (PHF x N x f _{HV} x f _p)		Design LOS	
2110	pc/h/ln	v _p = (V or DDHV) / (PHF x N x f _{HV} x f _p)	
S	57.9	mph	pc/h/ln
D = v _p / S	36.5	pc/mi/ln	S
LOS	E	D = v _p / S	
		pc/mi/ln	
		Required Number of Lanes, N	
Glossary		Factor Location	
N - Number of lanes	S - Speed	E _R - Exhibits 11-10, 11-12	f _{LW} - Exhibit 11-8
V - Hourly volume	D - Density	E _T - Exhibits 11-10, 11-11, 11-13	f _{LC} - Exhibit 11-9
v _p - Flow rate	FFS - Free-flow speed	f _p - Page 11-18	TRD - Page 11-11
LOS - Level of service	BFFS - Base free-flow speed	LOS, S, FFS, v _p - Exhibits 11-2, 11-3	
DDHV - Directional design hour volume			

BASIC FREEWAY SEGMENTS WORKSHEET			
General Information		Site Information	
Analyst	BAR	Highway/Direction of Travel I-26	
Agency or Company	HNTB North Carolina, PC	From/To	NC 280 to US 25
Date Performed	7/12/2013	Jurisdiction	Buncombe County
Analysis Time Period	Peak	Analysis Year	2030 Build 6 Lanes
Project Description STIP I4400/I-4700 - I-26 Widening			
<input checked="" type="checkbox"/> Oper.(LOS)		<input type="checkbox"/> Des.(N)	
<input type="checkbox"/> Planning Data			
Flow Inputs			
Volume, V	4634	veh/h	Peak-Hour Factor, PHF 0.90
AADT		veh/day	%Trucks and Buses, P _T 6
Peak-Hr Prop. of AADT, K			%RVs, P _R 0
Peak-Hr Direction Prop, D			General Terrain: Rolling
DDHV = AADT x K x D		veh/h	Grade % Length mi
			Up/Down %
Calculate Flow Adjustments			
f _p	1.00	E _R	2.0
E _T	2.5	f _{HV} = 1/[1+P _T (E _T - 1) + P _R (E _R - 1)] 0.917	
Speed Inputs		Calc Speed Adj and FFS	
Lane Width	ft		
Rt-Side Lat. Clearance	ft	f _{LW}	mph
Number of Lanes, N	3	f _{LC}	mph
Total Ramp Density, TRD	ramps/mi	TRD Adjustment	mph
FFS (measured)	65.0	FFS	65.0
Base free-flow Speed, BFFS	mph		mph
LOS and Performance Measures		Design (N)	
<u>Operational (LOS)</u>		<u>Design (N)</u>	
v _p = (V or DDHV) / (PHF x N x f _{HV} x f _p)	1871 pc/h/ln	Design LOS	
S	61.9 mph	v _p = (V or DDHV) / (PHF x N x f _{HV} x f _p)	pc/h/ln
D = v _p / S	30.2 pc/mi/ln	S	mph
LOS	D	D = v _p / S	pc/mi/ln
		Required Number of Lanes, N	
Glossary		Factor Location	
N - Number of lanes	S - Speed	E _R - Exhibits 11-10, 11-12	f _{LW} - Exhibit 11-8
V - Hourly volume	D - Density	E _T - Exhibits 11-10, 11-11, 11-13	f _{LC} - Exhibit 11-9
v _p - Flow rate	FFS - Free-flow speed	f _p - Page 11-18	TRD - Page 11-11
LOS - Level of service	BFFS - Base free-flow speed	LOS, S, FFS, v _p - Exhibits 11-2, 11-3	
DDHV - Directional design hour volume			

BASIC FREEWAY SEGMENTS WORKSHEET			
General Information		Site Information	
Analyst	BAR	Highway/Direction of Travel	I-26
Agency or Company	HNTB North Carolina, PC	From/To	US 25 to US 64
Date Performed	7/12/2013	Jurisdiction	Buncombe County
Analysis Time Period	Peak	Analysis Year	2030 Build 6 Lanes
Project Description <i>STIP I4400/I-4700 - I-26 Widening</i>			
<input checked="" type="checkbox"/> Oper.(LOS)		<input type="checkbox"/> Des.(N)	<input type="checkbox"/> Planning Data
Flow Inputs			
Volume, V	4299	veh/h	Peak-Hour Factor, PHF
AADT		veh/day	0.90
Peak-Hr Prop. of AADT, K			%Trucks and Buses, P _T
Peak-Hr Direction Prop, D			6
DDHV = AADT x K x D		veh/h	%RVs, P _R
			0
			General Terrain:
			Rolling
			Grade % Length
			mi
			Up/Down %
Calculate Flow Adjustments			
f _p	1.00	E _R	2.0
E _T	2.5	f _{HV} = 1/[1+P _T (E _T - 1) + P _R (E _R - 1)]	
Speed Inputs		Calc Speed Adj and FFS	
Lane Width	ft		
Rt-Side Lat. Clearance	ft	f _{LW}	mph
Number of Lanes, N	3	f _{LC}	mph
Total Ramp Density, TRD	ramps/mi	TRD Adjustment	mph
FFS (measured)	70.0	FFS	70.0
Base free-flow Speed, BFFS	mph		
LOS and Performance Measures		Design (N)	
<u>Operational (LOS)</u>		<u>Design (N)</u>	
v _p = (V or DDHV) / (PHF x N x f _{HV} x f _p)		Design LOS	
1736	pc/h/ln	v _p = (V or DDHV) / (PHF x N x f _{HV} x f _p)	
S	66.7	pc/h/ln	
D = v _p / S	26.0	S	
LOS	D	mph	
		D = v _p / S	
		pc/mi/ln	
		Required Number of Lanes, N	
Glossary		Factor Location	
N - Number of lanes	S - Speed	E _R - Exhibits 11-10, 11-12	f _{LW} - Exhibit 11-8
V - Hourly volume	D - Density	E _T - Exhibits 11-10, 11-11, 11-13	f _{LC} - Exhibit 11-9
v _p - Flow rate	FFS - Free-flow speed	f _p - Page 11-18	TRD - Page 11-11
LOS - Level of service	BFFS - Base free-flow speed	LOS, S, FFS, v _p - Exhibits 11-2, 11-3	
DDHV - Directional design hour volume			

BASIC FREEWAY SEGMENTS WORKSHEET			
General Information		Site Information	
Analyst	BAR	Highway/Direction of Travel	I-26
Agency or Company	HNTB North Carolina, PC	From/To	US 64 to Upward Road
Date Performed	7/12/2013	Jurisdiction	Buncombe County
Analysis Time Period	Peak	Analysis Year	2030 Build 6 Lanes
Project Description <i>STIP I4400/I-4700 - I-26 Widening</i>			
<input checked="" type="checkbox"/> Oper.(LOS)		<input type="checkbox"/> Des.(N)	
<input type="checkbox"/> Planning Data			
Flow Inputs			
Volume, V	3893	veh/h	Peak-Hour Factor, PHF
AADT		veh/day	0.90
Peak-Hr Prop. of AADT, K			%Trucks and Buses, P _T
Peak-Hr Direction Prop, D			6
DDHV = AADT x K x D		veh/h	%RVs, P _R
			0
			General Terrain:
			Rolling
			Grade % Length
			mi
			Up/Down %
Calculate Flow Adjustments			
f _p	1.00	E _R	2.0
E _T	2.5	f _{HV} = 1/[1+P _T (E _T - 1) + P _R (E _R - 1)]	
Speed Inputs		Calc Speed Adj and FFS	
Lane Width	ft		
Rt-Side Lat. Clearance	ft	f _{LW}	mph
Number of Lanes, N	3	f _{LC}	mph
Total Ramp Density, TRD	ramps/mi	TRD Adjustment	mph
FFS (measured)	70.0	FFS	70.0
Base free-flow Speed, BFFS	mph		
LOS and Performance Measures		Design (N)	
<u>Operational (LOS)</u>		<u>Design (N)</u>	
v _p = (V or DDHV) / (PHF x N x f _{HV} x f _p)		Design LOS	
1572	pc/h/ln	v _p = (V or DDHV) / (PHF x N x f _{HV} x f _p)	
S	68.4	pc/h/ln	
D = v _p / S	23.0	S	
LOS	C	mph	
		D = v _p / S	
		pc/mi/ln	
		Required Number of Lanes, N	
Glossary		Factor Location	
N - Number of lanes	S - Speed	E _R - Exhibits 11-10, 11-12	f _{LW} - Exhibit 11-8
V - Hourly volume	D - Density	E _T - Exhibits 11-10, 11-11, 11-13	f _{LC} - Exhibit 11-9
v _p - Flow rate	FFS - Free-flow speed	f _p - Page 11-18	TRD - Page 11-11
LOS - Level of service	BFFS - Base free-flow speed	LOS, S, FFS, v _p - Exhibits 11-2, 11-3	
DDHV - Directional design hour volume			

BASIC FREEWAY SEGMENTS WORKSHEET			
General Information		Site Information	
Analyst	BAR	Highway/Direction of Travel I-26	
Agency or Company	HNTB North Carolina, PC	From/To	I-40 to NC 191
Date Performed	7/12/2013	Jurisdiction	Buncombe County
Analysis Time Period	Peak	Analysis Year	2035 Build 6 Lanes
Project Description STIP I4400/I-4700 - I-26 Widening			
<input checked="" type="checkbox"/> Oper.(LOS)		<input type="checkbox"/> Des.(N)	
<input type="checkbox"/> Planning Data			
Flow Inputs			
Volume, V	5789	veh/h	Peak-Hour Factor, PHF 0.90
AADT		veh/day	%Trucks and Buses, P _T 6
Peak-Hr Prop. of AADT, K			%RVs, P _R 0
Peak-Hr Direction Prop, D			General Terrain: Rolling
DDHV = AADT x K x D		veh/h	Grade % Length mi
			Up/Down %
Calculate Flow Adjustments			
f _p	1.00	E _R	2.0
E _T	2.5	f _{HV} = 1/[1+P _T (E _T - 1) + P _R (E _R - 1)] 0.917	
Speed Inputs		Calc Speed Adj and FFS	
Lane Width	ft		
Rt-Side Lat. Clearance	ft	f _{LW}	mph
Number of Lanes, N	3	f _{LC}	mph
Total Ramp Density, TRD	ramps/mi	TRD Adjustment	mph
FFS (measured)	65.0	FFS	65.0
Base free-flow Speed, BFFS	mph		mph
LOS and Performance Measures		Design (N)	
<u>Operational (LOS)</u>		<u>Design (N)</u>	
v _p = (V or DDHV) / (PHF x N x f _{HV} x f _p)	2337 pc/h/ln	Design LOS	
S	52.6 mph	v _p = (V or DDHV) / (PHF x N x f _{HV} x f _p)	pc/h/ln
D = v _p / S	44.5 pc/mi/ln	S	mph
LOS	E	D = v _p / S	pc/mi/ln
		Required Number of Lanes, N	
Glossary		Factor Location	
N - Number of lanes	S - Speed	E _R - Exhibits 11-10, 11-12	f _{LW} - Exhibit 11-8
V - Hourly volume	D - Density	E _T - Exhibits 11-10, 11-11, 11-13	f _{LC} - Exhibit 11-9
v _p - Flow rate	FFS - Free-flow speed	f _p - Page 11-18	TRD - Page 11-11
LOS - Level of service	BFFS - Base free-flow speed	LOS, S, FFS, v _p - Exhibits 11-2, 11-3	
DDHV - Directional design hour volume			

BASIC FREEWAY SEGMENTS WORKSHEET			
General Information		Site Information	
Analyst	BAR	Highway/Direction of Travel I-26	
Agency or Company	HNTB North Carolina, PC	From/To	NC 146 to NC 280
Date Performed	7/12/2013	Jurisdiction	Buncombe County
Analysis Time Period	Peak	Analysis Year	2035 Build 6 Lanes
Project Description STIP I4400/I-4700 - I-26 Widening			
<input checked="" type="checkbox"/> Oper.(LOS)		<input type="checkbox"/> Des.(N)	
<input type="checkbox"/> Planning Data			
Flow Inputs			
Volume, V	5511	veh/h	Peak-Hour Factor, PHF 0.90
AADT		veh/day	%Trucks and Buses, P _T 5
Peak-Hr Prop. of AADT, K			%RVs, P _R 0
Peak-Hr Direction Prop, D			General Terrain: Rolling
DDHV = AADT x K x D		veh/h	Grade % Length mi
			Up/Down %
Calculate Flow Adjustments			
f _p	1.00	E _R	2.0
E _T	2.5	f _{HV} = 1/[1+P _T (E _T - 1) + P _R (E _R - 1)] 0.930	
Speed Inputs		Calc Speed Adj and FFS	
Lane Width	ft		
Rt-Side Lat. Clearance	ft	f _{LW}	mph
Number of Lanes, N	3	f _{LC}	mph
Total Ramp Density, TRD	ramps/mi	TRD Adjustment	mph
FFS (measured)	65.0	FFS	65.0
Base free-flow Speed, BFFS	mph		
LOS and Performance Measures		Design (N)	
<u>Operational (LOS)</u>		<u>Design (N)</u>	
v _p = (V or DDHV) / (PHF x N x f _{HV} x f _p)	2194 pc/h/ln	Design LOS	
S	56.1 mph	v _p = (V or DDHV) / (PHF x N x f _{HV} x f _p)	pc/h/ln
D = v _p / S	39.1 pc/mi/ln	S	mph
LOS	E	D = v _p / S	pc/mi/ln
		Required Number of Lanes, N	
Glossary		Factor Location	
N - Number of lanes	S - Speed	E _R - Exhibits 11-10, 11-12	f _{LW} - Exhibit 11-8
V - Hourly volume	D - Density	E _T - Exhibits 11-10, 11-11, 11-13	f _{LC} - Exhibit 11-9
v _p - Flow rate	FFS - Free-flow speed	f _p - Page 11-18	TRD - Page 11-11
LOS - Level of service	BFFS - Base free-flow speed	LOS, S, FFS, v _p - Exhibits 11-2, 11-3	
DDHV - Directional design hour volume			

BASIC FREEWAY SEGMENTS WORKSHEET											
General Information		Site Information									
Analyst	BAR	Highway/Direction of Travel I-26									
Agency or Company	HNTB North Carolina, PC	From/To	NC 280 to US 25								
Date Performed	7/12/2013	Jurisdiction	Buncombe County								
Analysis Time Period	Peak	Analysis Year	2035 Build 6 Lanes								
Project Description STIP I4400/I-4700 - I-26 Widening											
<input checked="" type="checkbox"/> Oper.(LOS)		<input type="checkbox"/> Des.(N)									
<input type="checkbox"/> Planning Data											
Flow Inputs											
Volume, V	4954	veh/h	Peak-Hour Factor, PHF 0.90								
AADT		veh/day	%Trucks and Buses, P _T 6								
Peak-Hr Prop. of AADT, K			%RVs, P _R 0								
Peak-Hr Direction Prop, D			General Terrain: Rolling								
DDHV = AADT x K x D		veh/h	Grade % Length mi								
			Up/Down %								
Calculate Flow Adjustments											
f _p	1.00	E _R	2.0								
E _T	2.5	f _{HV} = 1/[1+P _T (E _T - 1) + P _R (E _R - 1)] 0.917									
Speed Inputs		Calc Speed Adj and FFS									
Lane Width	ft	<table style="width:100%; border-collapse: collapse;"> <tr> <td style="padding: 5px;">f_{LW}</td> <td style="padding: 5px;">mph</td> </tr> <tr> <td style="padding: 5px;">f_{LC}</td> <td style="padding: 5px;">mph</td> </tr> <tr> <td style="padding: 5px;">TRD Adjustment</td> <td style="padding: 5px;">mph</td> </tr> <tr> <td style="padding: 5px;">FFS</td> <td style="padding: 5px;">65.0 mph</td> </tr> </table>		f _{LW}	mph	f _{LC}	mph	TRD Adjustment	mph	FFS	65.0 mph
f _{LW}	mph										
f _{LC}	mph										
TRD Adjustment	mph										
FFS	65.0 mph										
Rt-Side Lat. Clearance	ft										
Number of Lanes, N	3										
Total Ramp Density, TRD	ramps/mi										
FFS (measured)	65.0 mph										
Base free-flow Speed, BFFS	mph										
LOS and Performance Measures		Design (N)									
<u>Operational (LOS)</u>		<u>Design (N)</u>									
v _p = (V or DDHV) / (PHF x N x f _{HV} x f _p)	2000 pc/h/ln	Design LOS									
S	59.9 mph	v _p = (V or DDHV) / (PHF x N x f _{HV} x f _p)	pc/h/ln								
D = v _p / S	33.4 pc/mi/ln	S	mph								
LOS	D	D = v _p / S	pc/mi/ln								
		Required Number of Lanes, N									
Glossary		Factor Location									
N - Number of lanes	S - Speed	E _R - Exhibits 11-10, 11-12	f _{LW} - Exhibit 11-8								
V - Hourly volume	D - Density	E _T - Exhibits 11-10, 11-11, 11-13	f _{LC} - Exhibit 11-9								
v _p - Flow rate	FFS - Free-flow speed	f _p - Page 11-18	TRD - Page 11-11								
LOS - Level of service	BFFS - Base free-flow speed	LOS, S, FFS, v _p - Exhibits 11-2, 11-3									
DDHV - Directional design hour volume											

BASIC FREEWAY SEGMENTS WORKSHEET			
General Information		Site Information	
Analyst	BAR	Highway/Direction of Travel	I-26
Agency or Company	HNTB North Carolina, PC	From/To	US 25 to US 64
Date Performed	7/12/2013	Jurisdiction	Buncombe County
Analysis Time Period	Peak	Analysis Year	2035 Build 6 Lanes
Project Description <i>STIP I4400/I-4700 - I-26 Widening</i>			
<input checked="" type="checkbox"/> Oper.(LOS)		<input type="checkbox"/> Des.(N)	
<input type="checkbox"/> Planning Data			
Flow Inputs			
Volume, V	4622	veh/h	Peak-Hour Factor, PHF
AADT		veh/day	0.90
Peak-Hr Prop. of AADT, K			%Trucks and Buses, P _T
Peak-Hr Direction Prop, D			6
DDHV = AADT x K x D		veh/h	%RVs, P _R
			0
			General Terrain:
			Rolling
			Grade % Length
			mi
			Up/Down %
Calculate Flow Adjustments			
f _p	1.00	E _R	2.0
E _T	2.5	f _{HV} = 1/[1+P _T (E _T - 1) + P _R (E _R - 1)]	
Speed Inputs		Calc Speed Adj and FFS	
Lane Width	ft		
Rt-Side Lat. Clearance	ft	f _{LW}	mph
Number of Lanes, N	3	f _{LC}	mph
Total Ramp Density, TRD	ramps/mi	TRD Adjustment	mph
FFS (measured)	70.0	FFS	70.0
Base free-flow Speed, BFFS	mph		
LOS and Performance Measures		Design (N)	
<u>Operational (LOS)</u>		<u>Design (N)</u>	
v _p = (V or DDHV) / (PHF x N x f _{HV} x f _p)	1866	Design LOS	
S	64.9	v _p = (V or DDHV) / (PHF x N x f _{HV} x f _p)	pc/h/ln
D = v _p / S	28.8	S	mph
LOS	D	D = v _p / S	pc/mi/ln
		Required Number of Lanes, N	
Glossary		Factor Location	
N - Number of lanes	S - Speed	E _R - Exhibits 11-10, 11-12	f _{LW} - Exhibit 11-8
V - Hourly volume	D - Density	E _T - Exhibits 11-10, 11-11, 11-13	f _{LC} - Exhibit 11-9
v _p - Flow rate	FFS - Free-flow speed	f _p - Page 11-18	TRD - Page 11-11
LOS - Level of service	BFFS - Base free-flow speed	LOS, S, FFS, v _p - Exhibits 11-2, 11-3	
DDHV - Directional design hour volume			

BASIC FREEWAY SEGMENTS WORKSHEET			
General Information		Site Information	
Analyst	BAR	Highway/Direction of Travel	I-26
Agency or Company	HNTB North Carolina, PC	From/To	US 64 to Upward Road
Date Performed	7/12/2013	Jurisdiction	Buncombe County
Analysis Time Period	Peak	Analysis Year	2035 Build 6 Lanes
Project Description <i>STIP I4400/I-4700 - I-26 Widening</i>			
<input checked="" type="checkbox"/> Oper.(LOS)		<input type="checkbox"/> Des.(N)	
<input type="checkbox"/> Planning Data			
Flow Inputs			
Volume, V	4214	veh/h	Peak-Hour Factor, PHF
AADT		veh/day	0.90
Peak-Hr Prop. of AADT, K			%Trucks and Buses, P _T
Peak-Hr Direction Prop, D			6
DDHV = AADT x K x D		veh/h	%RVs, P _R
			0
			General Terrain:
			Rolling
			Grade % Length
			mi
			Up/Down %
Calculate Flow Adjustments			
f _p	1.00	E _R	2.0
E _T	2.5	f _{HV} = 1/[1+P _T (E _T - 1) + P _R (E _R - 1)]	0.917
Speed Inputs		Calc Speed Adj and FFS	
Lane Width	ft		
Rt-Side Lat. Clearance	ft	f _{LW}	mph
Number of Lanes, N	3	f _{LC}	mph
Total Ramp Density, TRD	ramps/mi	TRD Adjustment	mph
FFS (measured)	70.0	FFS	70.0
Base free-flow Speed, BFFS	mph		mph
LOS and Performance Measures		Design (N)	
<u>Operational (LOS)</u>		<u>Design (N)</u>	
v _p = (V or DDHV) / (PHF x N x f _{HV} x f _p)		Design LOS	
1701	pc/h/ln	v _p = (V or DDHV) / (PHF x N x f _{HV} x f _p)	
S	67.1	mph	pc/h/ln
D = v _p / S	25.4	pc/mi/ln	mph
LOS	C	D = v _p / S	
		pc/mi/ln	
		Required Number of Lanes, N	
Glossary		Factor Location	
N - Number of lanes	S - Speed	E _R - Exhibits 11-10, 11-12	f _{LW} - Exhibit 11-8
V - Hourly volume	D - Density	E _T - Exhibits 11-10, 11-11, 11-13	f _{LC} - Exhibit 11-9
v _p - Flow rate	FFS - Free-flow speed	f _p - Page 11-18	TRD - Page 11-11
LOS - Level of service	BFFS - Base free-flow speed	LOS, S, FFS, v _p - Exhibits 11-2, 11-3	
DDHV - Directional design hour volume			

BASIC FREEWAY SEGMENTS WORKSHEET			
General Information		Site Information	
Analyst	BAR	Highway/Direction of Travel	I-26
Agency or Company	HNTB North Carolina, PC	From/To	I 40 to NC 191
Date Performed	7/12/2013	Jurisdiction	Buncombe County
Analysis Time Period	Peak	Analysis Year	2040 Build 6 Lanes
Project Description <i>STIP I4400/I-4700 - I-26 Widening</i>			
<input checked="" type="checkbox"/> Oper.(LOS)		<input type="checkbox"/> Des.(N)	
<input type="checkbox"/> Planning Data			
Flow Inputs			
Volume, V	5949	veh/h	Peak-Hour Factor, PHF
AADT		veh/day	0.90
Peak-Hr Prop. of AADT, K			%Trucks and Buses, P _T
Peak-Hr Direction Prop, D			6
DDHV = AADT x K x D		veh/h	%RVs, P _R
			0
			General Terrain:
			Rolling
			Grade % Length
			mi
			Up/Down %
Calculate Flow Adjustments			
f _p	1.00	E _R	2.0
E _T	2.5	f _{HV} = 1/[1+P _T (E _T - 1) + P _R (E _R - 1)]	0.917
Speed Inputs		Calc Speed Adj and FFS	
Lane Width	ft		
Rt-Side Lat. Clearance	ft	f _{LW}	mph
Number of Lanes, N	3	f _{LC}	mph
Total Ramp Density, TRD	ramps/mi	TRD Adjustment	mph
FFS (measured)	65.0	FFS	65.0
Base free-flow Speed, BFFS	mph		mph
LOS and Performance Measures		Design (N)	
<u>Operational (LOS)</u>		<u>Design (N)</u>	
v _p = (V or DDHV) / (PHF x N x f _{HV})		Design LOS	
2402	pc/h/ln	v _p = (V or DDHV) / (PHF x N x f _{HV})	
x f _p)		pc/h/ln	
S	50.8	x f _p)	
S	mph	S	mph
D = v _p / S	47.3	D = v _p / S	pc/mi/ln
47.3	pc/mi/ln	Required Number of Lanes, N	
LOS	F		
Glossary		Factor Location	
N - Number of lanes	S - Speed	E _R - Exhibits 11-10, 11-12	f _{LW} - Exhibit 11-8
V - Hourly volume	D - Density	E _T - Exhibits 11-10, 11-11, 11-13	f _{LC} - Exhibit 11-9
v _p - Flow rate	FFS - Free-flow speed	f _p - Page 11-18	TRD - Page 11-11
LOS - Level of service	BFFS - Base free-flow speed	LOS, S, FFS, v _p - Exhibits 11-2, 11-3	
DDHV - Directional design hour volume			

BASIC FREEWAY SEGMENTS WORKSHEET			
General Information		Site Information	
Analyst	BAR	Highway/Direction of Travel I-26	
Agency or Company	HNTB North Carolina, PC	From/To	NC 146 to NC 280
Date Performed	7/12/2013	Jurisdiction	Buncombe County
Analysis Time Period	Peak	Analysis Year	2040 Build 6 Lanes
Project Description STIP I4400/I-4700 - I-26 Widening			
<input checked="" type="checkbox"/> Oper.(LOS)		<input type="checkbox"/> Des.(N)	
<input type="checkbox"/> Planning Data			
Flow Inputs			
Volume, V	5723	veh/h	Peak-Hour Factor, PHF 0.90
AADT		veh/day	%Trucks and Buses, P _T 5
Peak-Hr Prop. of AADT, K			%RVs, P _R 0
Peak-Hr Direction Prop, D			General Terrain: Rolling
DDHV = AADT x K x D		veh/h	Grade % Length mi
			Up/Down %
Calculate Flow Adjustments			
f _p	1.00	E _R	2.0
E _T	2.5	f _{HV} = 1/[1+P _T (E _T - 1) + P _R (E _R - 1)] 0.930	
Speed Inputs		Calc Speed Adj and FFS	
Lane Width	ft		
Rt-Side Lat. Clearance	ft	f _{LW}	mph
Number of Lanes, N	3	f _{LC}	mph
Total Ramp Density, TRD	ramps/mi	TRD Adjustment	mph
FFS (measured)	65.0	FFS	65.0
Base free-flow Speed, BFFS	mph		mph
LOS and Performance Measures		Design (N)	
<u>Operational (LOS)</u>		<u>Design (N)</u>	
v _p = (V or DDHV) / (PHF x N x f _{HV} x f _p)	2279 pc/h/ln	Design LOS	
S	54.0 mph	v _p = (V or DDHV) / (PHF x N x f _{HV} x f _p)	pc/h/ln
D = v _p / S	42.2 pc/mi/ln	S	mph
LOS	E	D = v _p / S	pc/mi/ln
		Required Number of Lanes, N	
Glossary		Factor Location	
N - Number of lanes	S - Speed	E _R - Exhibits 11-10, 11-12	f _{LW} - Exhibit 11-8
V - Hourly volume	D - Density	E _T - Exhibits 11-10, 11-11, 11-13	f _{LC} - Exhibit 11-9
v _p - Flow rate	FFS - Free-flow speed	f _p - Page 11-18	TRD - Page 11-11
LOS - Level of service	BFFS - Base free-flow speed	LOS, S, FFS, v _p - Exhibits 11-2, 11-3	
DDHV - Directional design hour volume			

BASIC FREEWAY SEGMENTS WORKSHEET			
General Information		Site Information	
Analyst	BAR	Highway/Direction of Travel I-26	
Agency or Company	HNTB North Carolina, PC	From/To	NC 280 to US 25
Date Performed	7/12/2013	Jurisdiction	Buncombe County
Analysis Time Period	Peak	Analysis Year	2040 Build 6 Lanes
Project Description STIP I4400/I-4700 - I-26 Widening			
<input checked="" type="checkbox"/> Oper.(LOS)		<input type="checkbox"/> Des.(N)	
<input type="checkbox"/> Planning Data			
Flow Inputs			
Volume, V	5275	veh/h	Peak-Hour Factor, PHF 0.90
AADT		veh/day	%Trucks and Buses, P _T 6
Peak-Hr Prop. of AADT, K			%RVs, P _R 0
Peak-Hr Direction Prop, D			General Terrain: Rolling
DDHV = AADT x K x D		veh/h	Grade % Length mi
			Up/Down %
Calculate Flow Adjustments			
f _p	1.00	E _R	2.0
E _T	2.5	f _{HV} = 1/[1+P _T (E _T - 1) + P _R (E _R - 1)] 0.917	
Speed Inputs		Calc Speed Adj and FFS	
Lane Width	ft		
Rt-Side Lat. Clearance	ft	f _{LW}	mph
Number of Lanes, N	3	f _{LC}	mph
Total Ramp Density, TRD	ramps/mi	TRD Adjustment	mph
FFS (measured)	65.0	FFS	65.0
Base free-flow Speed, BFFS	mph		
LOS and Performance Measures		Design (N)	
<u>Operational (LOS)</u>		<u>Design (N)</u>	
v _p = (V or DDHV) / (PHF x N x f _{HV})		Design LOS	
2130	pc/h/ln	v _p = (V or DDHV) / (PHF x N x f _{HV})	
x f _p)		pc/h/ln	
S	57.4	x f _p)	
S	mph	S	mph
D = v _p / S	37.1	D = v _p / S	pc/mi/ln
37.1	pc/mi/ln	Required Number of Lanes, N	
LOS	E		
Glossary		Factor Location	
N - Number of lanes	S - Speed	E _R - Exhibits 11-10, 11-12	f _{LW} - Exhibit 11-8
V - Hourly volume	D - Density	E _T - Exhibits 11-10, 11-11, 11-13	f _{LC} - Exhibit 11-9
v _p - Flow rate	FFS - Free-flow speed	f _p - Page 11-18	TRD - Page 11-11
LOS - Level of service	BFFS - Base free-flow speed	LOS, S, FFS, v _p - Exhibits 11-2, 11-3	
DDHV - Directional design hour volume			

BASIC FREEWAY SEGMENTS WORKSHEET			
General Information		Site Information	
Analyst	BAR	Highway/Direction of Travel	I-26
Agency or Company	HNTB North Carolina, PC	From/To	US 25 to US 64
Date Performed	7/12/2013	Jurisdiction	Buncombe County
Analysis Time Period	Peak	Analysis Year	2040 Build 6 Lanes
Project Description <i>STIP I4400/I-4700 - I-26 Widening</i>			
<input checked="" type="checkbox"/> Oper.(LOS)		<input type="checkbox"/> Des.(N)	
<input type="checkbox"/> Planning Data			
Flow Inputs			
Volume, V	4945	veh/h	Peak-Hour Factor, PHF
AADT		veh/day	0.90
Peak-Hr Prop. of AADT, K			%Trucks and Buses, P _T
Peak-Hr Direction Prop, D			6
DDHV = AADT x K x D		veh/h	%RVs, P _R
			0
			General Terrain:
			Rolling
			Grade % Length
			mi
			Up/Down %
Calculate Flow Adjustments			
f _p	1.00	E _R	2.0
E _T	2.5	f _{HV} = 1/[1+P _T (E _T - 1) + P _R (E _R - 1)]	0.917
Speed Inputs		Calc Speed Adj and FFS	
Lane Width	ft		
Rt-Side Lat. Clearance	ft	f _{LW}	mph
Number of Lanes, N	3	f _{LC}	mph
Total Ramp Density, TRD	ramps/mi	TRD Adjustment	mph
FFS (measured)	70.0	FFS	70.0
Base free-flow Speed, BFFS	mph		mph
LOS and Performance Measures		Design (N)	
<u>Operational (LOS)</u>		<u>Design (N)</u>	
v _p = (V or DDHV) / (PHF x N x f _{HV} x f _p)		Design LOS	
1996	pc/h/ln	v _p = (V or DDHV) / (PHF x N x f _{HV} x f _p)	
S	62.7	mph	pc/h/ln
D = v _p / S	31.9	pc/mi/ln	mph
LOS	D	D = v _p / S	
		pc/mi/ln	
		Required Number of Lanes, N	
Glossary		Factor Location	
N - Number of lanes	S - Speed	E _R - Exhibits 11-10, 11-12	f _{LW} - Exhibit 11-8
V - Hourly volume	D - Density	E _T - Exhibits 11-10, 11-11, 11-13	f _{LC} - Exhibit 11-9
v _p - Flow rate	FFS - Free-flow speed	f _p - Page 11-18	TRD - Page 11-11
LOS - Level of service	BFFS - Base free-flow speed	LOS, S, FFS, v _p - Exhibits 11-2, 11-3	
DDHV - Directional design hour volume			

BASIC FREEWAY SEGMENTS WORKSHEET			
General Information		Site Information	
Analyst	BAR	Highway/Direction of Travel	I-26
Agency or Company	HNTB North Carolina, PC	From/To	US 64 to Upward Road
Date Performed	7/12/2013	Jurisdiction	Buncombe County
Analysis Time Period	Peak	Analysis Year	2040 Build 6 Lanes
Project Description <i>STIP I4400/I-4700 - I-26 Widening</i>			
<input checked="" type="checkbox"/> Oper.(LOS)		<input type="checkbox"/> Des.(N)	
<input type="checkbox"/> Planning Data			
Flow Inputs			
Volume, V	4536	veh/h	Peak-Hour Factor, PHF
AADT		veh/day	0.90
Peak-Hr Prop. of AADT, K			%Trucks and Buses, P _T
Peak-Hr Direction Prop, D			6
DDHV = AADT x K x D		veh/h	%RVs, P _R
			0
			General Terrain:
			Rolling
			Grade % Length
			mi
			Up/Down %
Calculate Flow Adjustments			
f _p	1.00	E _R	2.0
E _T	2.5	f _{HV} = 1/[1+P _T (E _T - 1) + P _R (E _R - 1)]	
Speed Inputs		Calc Speed Adj and FFS	
Lane Width	ft		
Rt-Side Lat. Clearance	ft	f _{LW}	mph
Number of Lanes, N	3	f _{LC}	mph
Total Ramp Density, TRD	ramps/mi	TRD Adjustment	mph
FFS (measured)	70.0	FFS	70.0
Base free-flow Speed, BFFS	mph		
LOS and Performance Measures		Design (N)	
<u>Operational (LOS)</u>		<u>Design (N)</u>	
v _p = (V or DDHV) / (PHF x N x f _{HV} x f _p)		Design LOS	
1831	pc/h/ln	v _p = (V or DDHV) / (PHF x N x f _{HV} x f _p)	
S	65.4	pc/h/ln	
D = v _p / S	28.0	S	
LOS	D	mph	
		D = v _p / S	
		pc/mi/ln	
		Required Number of Lanes, N	
Glossary		Factor Location	
N - Number of lanes	S - Speed	E _R - Exhibits 11-10, 11-12	f _{LW} - Exhibit 11-8
V - Hourly volume	D - Density	E _T - Exhibits 11-10, 11-11, 11-13	f _{LC} - Exhibit 11-9
v _p - Flow rate	FFS - Free-flow speed	f _p - Page 11-18	TRD - Page 11-11
LOS - Level of service	BFFS - Base free-flow speed	LOS, S, FFS, v _p - Exhibits 11-2, 11-3	
DDHV - Directional design hour volume			

Build 8 Lane

BASIC FREEWAY SEGMENTS WORKSHEET			
General Information		Site Information	
Analyst	BAR	Highway/Direction of Travel I-26	
Agency or Company	HNTB North Carolina, PC	From/To	I-40 to NC 191
Date Performed	7/12/2013	Jurisdiction	Buncombe County
Analysis Time Period	Peak	Analysis Year	2011 Build 8 Lanes
Project Description STIP I4400/I-4700 - I-26 Widening			
<input checked="" type="checkbox"/> Oper.(LOS)		<input type="checkbox"/> Des.(N)	
<input type="checkbox"/> Planning Data			
Flow Inputs			
Volume, V	5165	veh/h	Peak-Hour Factor, PHF 0.90
AADT		veh/day	%Trucks and Buses, P _T 6
Peak-Hr Prop. of AADT, K			%RVs, P _R 0
Peak-Hr Direction Prop, D			General Terrain: Rolling
DDHV = AADT x K x D		veh/h	Grade % Length mi
			Up/Down %
Calculate Flow Adjustments			
f _p	1.00	E _R	2.0
E _T	2.5	f _{HV} = 1/[1+P _T (E _T - 1) + P _R (E _R - 1)] 0.917	
Speed Inputs		Calc Speed Adj and FFS	
Lane Width	ft		
Rt-Side Lat. Clearance	ft	f _{LW}	mph
Number of Lanes, N	4	f _{LC}	mph
Total Ramp Density, TRD	ramps/mi	TRD Adjustment	mph
FFS (measured)	65.0	FFS	65.0
Base free-flow Speed, BFFS	mph		mph
LOS and Performance Measures		Design (N)	
<u>Operational (LOS)</u>		<u>Design (N)</u>	
v _p = (V or DDHV) / (PHF x N x f _{HV} x f _p)		Design LOS	
v _p	1564	v _p = (V or DDHV) / (PHF x N x f _{HV} x f _p)	pc/h/ln
S	64.6	S	mph
D = v _p / S	24.2	D = v _p / S	pc/mi/ln
LOS	C	Required Number of Lanes, N	
Glossary		Factor Location	
N - Number of lanes	S - Speed	E _R - Exhibits 11-10, 11-12	f _{LW} - Exhibit 11-8
V - Hourly volume	D - Density	E _T - Exhibits 11-10, 11-11, 11-13	f _{LC} - Exhibit 11-9
v _p - Flow rate	FFS - Free-flow speed	f _p - Page 11-18	TRD - Page 11-11
LOS - Level of service	BFFS - Base free-flow speed	LOS, S, FFS, v _p - Exhibits 11-2, 11-3	
DDHV - Directional design hour volume			

BASIC FREEWAY SEGMENTS WORKSHEET											
General Information		Site Information									
Analyst	BAR	Highway/Direction of Travel I-26									
Agency or Company	HNTB North Carolina, PC	From/To	NC 146 to NC 280								
Date Performed	7/12/2013	Jurisdiction	Buncombe County								
Analysis Time Period	Peak	Analysis Year	2011 Build 8 Lanes								
Project Description STIP I4400/I-4700 - I-26 Widening											
<input checked="" type="checkbox"/> Oper.(LOS)		<input type="checkbox"/> Des.(N)									
<input type="checkbox"/> Planning Data											
Flow Inputs											
Volume, V	4645	veh/h	Peak-Hour Factor, PHF 0.90								
AADT		veh/day	%Trucks and Buses, P _T 5								
Peak-Hr Prop. of AADT, K			%RVs, P _R 0								
Peak-Hr Direction Prop, D			General Terrain: Rolling								
DDHV = AADT x K x D		veh/h	Grade % Length mi								
			Up/Down %								
Calculate Flow Adjustments											
f _p	1.00	E _R	2.0								
E _T	2.5	f _{HV} = 1/[1+P _T (E _T - 1) + P _R (E _R - 1)] 0.930									
Speed Inputs		Calc Speed Adj and FFS									
Lane Width	ft	<table style="width:100%; border-collapse: collapse;"> <tr> <td style="padding: 5px;">f_{LW}</td> <td style="padding: 5px;">mph</td> </tr> <tr> <td style="padding: 5px;">f_{LC}</td> <td style="padding: 5px;">mph</td> </tr> <tr> <td style="padding: 5px;">TRD Adjustment</td> <td style="padding: 5px;">mph</td> </tr> <tr> <td style="padding: 5px;">FFS</td> <td style="padding: 5px;">65.0 mph</td> </tr> </table>		f _{LW}	mph	f _{LC}	mph	TRD Adjustment	mph	FFS	65.0 mph
f _{LW}	mph										
f _{LC}	mph										
TRD Adjustment	mph										
FFS	65.0 mph										
Rt-Side Lat. Clearance	ft										
Number of Lanes, N	4										
Total Ramp Density, TRD	ramps/mi										
FFS (measured)	65.0 mph										
Base free-flow Speed, BFFS	mph										
LOS and Performance Measures		Design (N)									
<u>Operational (LOS)</u>		<u>Design (N)</u>									
v _p = (V or DDHV) / (PHF x N x f _{HV} x f _p)	1387 pc/h/ln	Design LOS									
S	65.0 mph	v _p = (V or DDHV) / (PHF x N x f _{HV} x f _p)	pc/h/ln								
D = v _p / S	21.3 pc/mi/ln	S	mph								
LOS	C	D = v _p / S	pc/mi/ln								
		Required Number of Lanes, N									
Glossary		Factor Location									
N - Number of lanes	S - Speed	E _R - Exhibits 11-10, 11-12	f _{LW} - Exhibit 11-8								
V - Hourly volume	D - Density	E _T - Exhibits 11-10, 11-11, 11-13	f _{LC} - Exhibit 11-9								
v _p - Flow rate	FFS - Free-flow speed	f _p - Page 11-18	TRD - Page 11-11								
LOS - Level of service speed	BFFS - Base free-flow speed	LOS, S, FFS, v _p - Exhibits 11-2, 11-3									
DDHV - Directional design hour volume											

BASIC FREEWAY SEGMENTS WORKSHEET			
General Information		Site Information	
Analyst	BAR	Highway/Direction of Travel I-26	
Agency or Company	HNTB North Carolina, PC	From/To	NC 280 to US 25
Date Performed	7/12/2013	Jurisdiction	Buncombe County
Analysis Time Period	Peak	Analysis Year	2011 Build 8 Lanes
Project Description STIP I4400/I-4700 - I-26 Widening			
<input checked="" type="checkbox"/> Oper.(LOS)		<input type="checkbox"/> Des.(N)	
<input type="checkbox"/> Planning Data			
Flow Inputs			
Volume, V	3516	veh/h	Peak-Hour Factor, PHF 0.90
AADT		veh/day	%Trucks and Buses, P _T 6
Peak-Hr Prop. of AADT, K			%RVs, P _R 0
Peak-Hr Direction Prop, D			General Terrain: Rolling
DDHV = AADT x K x D		veh/h	Grade % Length mi
			Up/Down %
Calculate Flow Adjustments			
f _p	1.00	E _R	2.0
E _T	2.5	f _{HV} = 1/[1+P _T (E _T - 1) + P _R (E _R - 1)] 0.917	
Speed Inputs		Calc Speed Adj and FFS	
Lane Width	ft		
Rt-Side Lat. Clearance	ft	f _{LW}	mph
Number of Lanes, N	4	f _{LC}	mph
Total Ramp Density, TRD	ramps/mi	TRD Adjustment	mph
FFS (measured)	65.0	FFS	65.0
Base free-flow Speed, BFFS	mph		mph
LOS and Performance Measures		Design (N)	
<u>Operational (LOS)</u>		<u>Design (N)</u>	
v _p = (V or DDHV) / (PHF x N x f _{HV} x f _p)	1065 pc/h/ln	Design LOS	
S	65.0 mph	v _p = (V or DDHV) / (PHF x N x f _{HV} x f _p)	pc/h/ln
D = v _p / S	16.4 pc/mi/ln	S	mph
LOS	B	D = v _p / S	pc/mi/ln
		Required Number of Lanes, N	
Glossary		Factor Location	
N - Number of lanes	S - Speed	E _R - Exhibits 11-10, 11-12	f _{LW} - Exhibit 11-8
V - Hourly volume	D - Density	E _T - Exhibits 11-10, 11-11, 11-13	f _{LC} - Exhibit 11-9
v _p - Flow rate	FFS - Free-flow speed	f _p - Page 11-18	TRD - Page 11-11
LOS - Level of service	BFFS - Base free-flow speed	LOS, S, FFS, v _p - Exhibits 11-2, 11-3	
DDHV - Directional design hour volume			

BASIC FREEWAY SEGMENTS WORKSHEET			
General Information		Site Information	
Analyst	BAR	Highway/Direction of Travel	I-26
Agency or Company	HNTB North Carolina, PC	From/To	US 25 to US 64
Date Performed	7/12/2013	Jurisdiction	Buncombe County
Analysis Time Period	Peak	Analysis Year	2011 Build 8 Lanes
Project Description <i>STIP I4400/I-4700 - I-26 Widening</i>			
<input checked="" type="checkbox"/> Oper.(LOS)		<input type="checkbox"/> Des.(N)	
<input type="checkbox"/> Planning Data			
Flow Inputs			
Volume, V	3151	veh/h	Peak-Hour Factor, PHF
AADT		veh/day	0.90
Peak-Hr Prop. of AADT, K			%Trucks and Buses, P _T
Peak-Hr Direction Prop, D			6
DDHV = AADT x K x D		veh/h	%RVs, P _R
			0
			General Terrain:
			Rolling
			Grade % Length
			mi
			Up/Down %
Calculate Flow Adjustments			
f _p	1.00	E _R	2.0
E _T	2.5	f _{HV} = 1/[1+P _T (E _T - 1) + P _R (E _R - 1)]	0.917
Speed Inputs		Calc Speed Adj and FFS	
Lane Width	ft		
Rt-Side Lat. Clearance	ft	f _{LW}	mph
Number of Lanes, N	4	f _{LC}	mph
Total Ramp Density, TRD	ramps/mi	TRD Adjustment	mph
FFS (measured)	70.0	FFS	70.0
Base free-flow Speed, BFFS	mph		mph
LOS and Performance Measures		Design (N)	
<u>Operational (LOS)</u>		<u>Design (N)</u>	
v _p = (V or DDHV) / (PHF x N x f _{HV})	954	Design LOS	
x f _p)		v _p = (V or DDHV) / (PHF x N x f _{HV})	pc/h/ln
S	70.0	x f _p)	
D = v _p / S	13.6	S	mph
LOS	B	D = v _p / S	pc/mi/ln
		Required Number of Lanes, N	
Glossary		Factor Location	
N - Number of lanes	S - Speed	E _R - Exhibits 11-10, 11-12	f _{LW} - Exhibit 11-8
V - Hourly volume	D - Density	E _T - Exhibits 11-10, 11-11, 11-13	f _{LC} - Exhibit 11-9
v _p - Flow rate	FFS - Free-flow speed	f _p - Page 11-18	TRD - Page 11-11
LOS - Level of service	BFFS - Base free-flow speed	LOS, S, FFS, v _p - Exhibits 11-2, 11-3	
DDHV - Directional design hour volume			

BASIC FREEWAY SEGMENTS WORKSHEET			
General Information		Site Information	
Analyst	BAR	Highway/Direction of Travel	I-26
Agency or Company	HNTB North Carolina, PC	From/To	US 64 to Upward Road
Date Performed	7/12/2013	Jurisdiction	Buncombe County
Analysis Time Period	Peak	Analysis Year	2011 Build 8 Lanes
Project Description <i>STIP I4400/I-4700 - I-26 Widening</i>			
<input checked="" type="checkbox"/> Oper.(LOS)		<input type="checkbox"/> Des.(N)	
<input type="checkbox"/> Planning Data			
Flow Inputs			
Volume, V	2699	veh/h	Peak-Hour Factor, PHF
AADT		veh/day	0.90
Peak-Hr Prop. of AADT, K			%Trucks and Buses, P _T
Peak-Hr Direction Prop, D			6
DDHV = AADT x K x D		veh/h	%RVs, P _R
			0
			General Terrain:
			Rolling
			Grade % Length
			mi
			Up/Down %
Calculate Flow Adjustments			
f _p	1.00	E _R	2.0
E _T	2.5	f _{HV} = 1/[1+P _T (E _T - 1) + P _R (E _R - 1)]	
Speed Inputs		Calc Speed Adj and FFS	
Lane Width	ft		
Rt-Side Lat. Clearance	ft	f _{LW}	mph
Number of Lanes, N	4	f _{LC}	mph
Total Ramp Density, TRD	ramps/mi	TRD Adjustment	mph
FFS (measured)	70.0	FFS	70.0
Base free-flow Speed, BFFS	mph		
LOS and Performance Measures		Design (N)	
<u>Operational (LOS)</u>		<u>Design (N)</u>	
v _p = (V or DDHV) / (PHF x N x f _{HV})		Design LOS	
817	pc/h/ln	v _p = (V or DDHV) / (PHF x N x f _{HV})	
x f _p)		pc/h/ln	
S	70.0	S	mph
D = v _p / S	11.7	D = v _p / S	pc/mi/ln
LOS	B	Required Number of Lanes, N	
Glossary		Factor Location	
N - Number of lanes	S - Speed	E _R - Exhibits 11-10, 11-12	f _{LW} - Exhibit 11-8
V - Hourly volume	D - Density	E _T - Exhibits 11-10, 11-11, 11-13	f _{LC} - Exhibit 11-9
v _p - Flow rate	FFS - Free-flow speed	f _p - Page 11-18	TRD - Page 11-11
LOS - Level of service	BFFS - Base free-flow speed	LOS, S, FFS, v _p - Exhibits 11-2, 11-3	
DDHV - Directional design hour volume			

BASIC FREEWAY SEGMENTS WORKSHEET			
General Information		Site Information	
Analyst	BAR	Highway/Direction of Travel	I-26
Agency or Company	HNTB North Carolina, PC	From/To	I 40 to NC 191
Date Performed	7/12/2013	Jurisdiction	Buncombe County
Analysis Time Period	Peak	Analysis Year	2015 Build 8 Lanes
Project Description <i>STIP I4400/I-4700 - I-26 Widening</i>			
<input checked="" type="checkbox"/> Oper.(LOS)		<input type="checkbox"/> Des.(N)	
<input type="checkbox"/> Planning Data			
Flow Inputs			
Volume, V	5327	veh/h	Peak-Hour Factor, PHF
AADT		veh/day	0.90
Peak-Hr Prop. of AADT, K			%Trucks and Buses, P _T
Peak-Hr Direction Prop, D			6
DDHV = AADT x K x D		veh/h	%RVs, P _R
			0
			General Terrain:
			Rolling
			Grade % Length
			mi
			Up/Down %
Calculate Flow Adjustments			
f _p	1.00	E _R	2.0
E _T	2.5	f _{HV} = 1/[1+P _T (E _T - 1) + P _R (E _R - 1)]	
Speed Inputs			
Lane Width		Calc Speed Adj and FFS	
Rt-Side Lat. Clearance		f _{LW}	
Number of Lanes, N		mph	
Total Ramp Density, TRD		f _{LC}	
FFS (measured)		TRD Adjustment	
Base free-flow Speed, BFFS		mph	
65.0		FFS	
mph		65.0	
mph		mph	
LOS and Performance Measures			
Design (N)		Design (N)	
Operational (LOS)		Design (N)	
v _p = (V or DDHV) / (PHF x N x f _{HV} x f _p)		Design LOS	
1613 pc/h/ln		v _p = (V or DDHV) / (PHF x N x f _{HV} x f _p)	
S		mph	
64.4		S	
D = v _p / S		mph	
25.1		D = v _p / S	
LOS		pc/mi/ln	
C		Required Number of Lanes, N	
Glossary			
Factor Location		Factor Location	
N - Number of lanes		E _R - Exhibits 11-10, 11-12	
S - Speed		f _{LW} - Exhibit 11-8	
V - Hourly volume		E _T - Exhibits 11-10, 11-11, 11-13	
D - Density		f _{LC} - Exhibit 11-9	
v _p - Flow rate		f _p - Page 11-18	
FFS - Free-flow speed		TRD - Page 11-11	
LOS - Level of service		LOS, S, FFS, v _p - Exhibits 11-2, 11-3	
BFFS - Base free-flow speed			
DDHV - Directional design hour volume			

BASIC FREEWAY SEGMENTS WORKSHEET			
General Information		Site Information	
Analyst	BAR	Highway/Direction of Travel I-26	
Agency or Company	HNTB North Carolina, PC	From/To	NC 146 to NC 280
Date Performed	7/12/2013	Jurisdiction	Buncombe County
Analysis Time Period	Peak	Analysis Year	2015 Build 8 Lanes
Project Description STIP I4400/I-4700 - I-26 Widening			
<input checked="" type="checkbox"/> Oper.(LOS)		<input type="checkbox"/> Des.(N)	
<input type="checkbox"/> Planning Data			
Flow Inputs			
Volume, V	4856	veh/h	Peak-Hour Factor, PHF 0.90
AADT		veh/day	%Trucks and Buses, P _T 5
Peak-Hr Prop. of AADT, K			%RVs, P _R 0
Peak-Hr Direction Prop, D			General Terrain: Rolling
DDHV = AADT x K x D		veh/h	Grade % Length mi
			Up/Down %
Calculate Flow Adjustments			
f _p	1.00	E _R	2.0
E _T	2.5	f _{HV} = 1/[1+P _T (E _T - 1) + P _R (E _R - 1)] 0.930	
Speed Inputs		Calc Speed Adj and FFS	
Lane Width	ft		
Rt-Side Lat. Clearance	ft	f _{LW}	mph
Number of Lanes, N	4	f _{LC}	mph
Total Ramp Density, TRD	ramps/mi	TRD Adjustment	mph
FFS (measured)	65.0	FFS	65.0
Base free-flow Speed, BFFS	mph		mph
LOS and Performance Measures		Design (N)	
<u>Operational (LOS)</u>		<u>Design (N)</u>	
v _p = (V or DDHV) / (PHF x N x f _{HV})		Design LOS	
1450	pc/h/ln	v _p = (V or DDHV) / (PHF x N x f _{HV})	
x f _p)		pc/h/ln	
S	65.0	mph	x f _p)
D = v _p / S	22.3	pc/mi/ln	S
LOS	C		D = v _p / S
			pc/mi/ln
		Required Number of Lanes, N	
Glossary		Factor Location	
N - Number of lanes	S - Speed	E _R - Exhibits 11-10, 11-12	f _{LW} - Exhibit 11-8
V - Hourly volume	D - Density	E _T - Exhibits 11-10, 11-11, 11-13	f _{LC} - Exhibit 11-9
v _p - Flow rate	FFS - Free-flow speed	f _p - Page 11-18	TRD - Page 11-11
LOS - Level of service	BFFS - Base free-flow speed	LOS, S, FFS, v _p - Exhibits 11-2, 11-3	
DDHV - Directional design hour volume			

BASIC FREEWAY SEGMENTS WORKSHEET			
General Information		Site Information	
Analyst	BAR	Highway/Direction of Travel I-26	
Agency or Company	HNTB North Carolina, PC	From/To	NC 280 to US 25
Date Performed	7/12/2013	Jurisdiction	Buncombe County
Analysis Time Period	Peak	Analysis Year	2015 Build 8 Lanes
Project Description STIP I4400/I-4700 - I-26 Widening			
<input checked="" type="checkbox"/> Oper.(LOS)		<input type="checkbox"/> Des.(N)	
<input type="checkbox"/> Planning Data			
Flow Inputs			
Volume, V	3813	veh/h	Peak-Hour Factor, PHF 0.90
AADT		veh/day	%Trucks and Buses, P _T 6
Peak-Hr Prop. of AADT, K			%RVs, P _R 0
Peak-Hr Direction Prop, D			General Terrain: Rolling
DDHV = AADT x K x D		veh/h	Grade % Length mi
			Up/Down %
Calculate Flow Adjustments			
f _p	1.00	E _R	2.0
E _T	2.5	f _{HV} = 1/[1+P _T (E _T - 1) + P _R (E _R - 1)] 0.917	
Speed Inputs		Calc Speed Adj and FFS	
Lane Width	ft		
Rt-Side Lat. Clearance	ft	f _{LW}	mph
Number of Lanes, N	4	f _{LC}	mph
Total Ramp Density, TRD	ramps/mi	TRD Adjustment	mph
FFS (measured)	65.0	FFS	65.0
Base free-flow Speed, BFFS	mph		mph
LOS and Performance Measures		Design (N)	
<u>Operational (LOS)</u>		<u>Design (N)</u>	
v _p = (V or DDHV) / (PHF x N x f _{HV} x f _p)	1154 pc/h/ln	Design LOS	
S	65.0 mph	v _p = (V or DDHV) / (PHF x N x f _{HV} x f _p)	pc/h/ln
D = v _p / S	17.8 pc/mi/ln	S	mph
LOS	B	D = v _p / S	pc/mi/ln
		Required Number of Lanes, N	
Glossary		Factor Location	
N - Number of lanes	S - Speed	E _R - Exhibits 11-10, 11-12	f _{LW} - Exhibit 11-8
V - Hourly volume	D - Density	E _T - Exhibits 11-10, 11-11, 11-13	f _{LC} - Exhibit 11-9
v _p - Flow rate	FFS - Free-flow speed	f _p - Page 11-18	TRD - Page 11-11
LOS - Level of service	BFFS - Base free-flow speed	LOS, S, FFS, v _p - Exhibits 11-2, 11-3	
DDHV - Directional design hour volume			

BASIC FREEWAY SEGMENTS WORKSHEET			
General Information		Site Information	
Analyst	BAR	Highway/Direction of Travel	I-26
Agency or Company	HNTB North Carolina, PC	From/To	US 25 to US 64
Date Performed	7/12/2013	Jurisdiction	Buncombe County
Analysis Time Period	Peak	Analysis Year	2015 Build 8 Lanes
Project Description <i>STIP I4400/I-4700 - I-26 Widening</i>			
<input checked="" type="checkbox"/> Oper.(LOS)		<input type="checkbox"/> Des.(N)	
<input type="checkbox"/> Planning Data			
Flow Inputs			
Volume, V	3449	veh/h	Peak-Hour Factor, PHF
AADT		veh/day	0.90
Peak-Hr Prop. of AADT, K			%Trucks and Buses, P _T
Peak-Hr Direction Prop, D			6
DDHV = AADT x K x D		veh/h	%RVs, P _R
			0
			General Terrain:
			Rolling
			Grade % Length
			mi
			Up/Down %
Calculate Flow Adjustments			
f _p	1.00	E _R	2.0
E _T	2.5	f _{HV} = 1/[1+P _T (E _T - 1) + P _R (E _R - 1)]	0.917
Speed Inputs		Calc Speed Adj and FFS	
Lane Width	ft		
Rt-Side Lat. Clearance	ft	f _{LW}	mph
Number of Lanes, N	4	f _{LC}	mph
Total Ramp Density, TRD	ramps/mi	TRD Adjustment	mph
FFS (measured)	70.0	FFS	70.0
Base free-flow Speed, BFFS	mph		mph
LOS and Performance Measures		Design (N)	
<u>Operational (LOS)</u>		<u>Design (N)</u>	
v _p = (V or DDHV) / (PHF x N x f _{HV} x f _p)		Design LOS	
1044	pc/h/ln	v _p = (V or DDHV) / (PHF x N x f _{HV} x f _p)	
S	70.0	mph	pc/h/ln
D = v _p / S	14.9	pc/mi/ln	S
LOS	B		mph
			pc/mi/ln
			D = v _p / S
			Required Number of Lanes, N
Glossary		Factor Location	
N - Number of lanes	S - Speed	E _R - Exhibits 11-10, 11-12	f _{LW} - Exhibit 11-8
V - Hourly volume	D - Density	E _T - Exhibits 11-10, 11-11, 11-13	f _{LC} - Exhibit 11-9
v _p - Flow rate	FFS - Free-flow speed	f _p - Page 11-18	TRD - Page 11-11
LOS - Level of service	BFFS - Base free-flow speed	LOS, S, FFS, v _p - Exhibits 11-2, 11-3	
DDHV - Directional design hour volume			

BASIC FREEWAY SEGMENTS WORKSHEET			
General Information		Site Information	
Analyst	BAR	Highway/Direction of Travel	I-26
Agency or Company	HNTB North Carolina, PC	From/To	US 64 to Upward Road
Date Performed	7/12/2013	Jurisdiction	Buncombe County
Analysis Time Period	Peak	Analysis Year	2015 Build 8 Lanes
Project Description <i>STIP I4400/I-4700 - I-26 Widening</i>			
<input checked="" type="checkbox"/> Oper.(LOS)		<input type="checkbox"/> Des.(N)	<input type="checkbox"/> Planning Data
Flow Inputs			
Volume, V	2971	veh/h	Peak-Hour Factor, PHF
AADT		veh/day	0.90
Peak-Hr Prop. of AADT, K			%Trucks and Buses, P _T
Peak-Hr Direction Prop, D			6
DDHV = AADT x K x D		veh/h	%RVs, P _R
			0
			General Terrain:
			Rolling
			Grade % Length
			mi
			Up/Down %
Calculate Flow Adjustments			
f _p	1.00	E _R	2.0
E _T	2.5	f _{HV} = 1/[1+P _T (E _T - 1) + P _R (E _R - 1)]	0.917
Speed Inputs		Calc Speed Adj and FFS	
Lane Width	ft		
Rt-Side Lat. Clearance	ft	f _{LW}	mph
Number of Lanes, N	4	f _{LC}	mph
Total Ramp Density, TRD	ramps/mi	TRD Adjustment	mph
FFS (measured)	70.0	FFS	70.0
Base free-flow Speed, BFFS	mph		mph
LOS and Performance Measures		Design (N)	
<u>Operational (LOS)</u>		<u>Design (N)</u>	
v _p = (V or DDHV) / (PHF x N x f _{HV})		Design LOS	
900	pc/h/ln	v _p = (V or DDHV) / (PHF x N x f _{HV})	
x f _p)		pc/h/ln	
S	70.0	S	mph
D = v _p / S	12.9	D = v _p / S	pc/mi/ln
LOS	B	Required Number of Lanes, N	
Glossary		Factor Location	
N - Number of lanes	S - Speed	E _R - Exhibits 11-10, 11-12	f _{LW} - Exhibit 11-8
V - Hourly volume	D - Density	E _T - Exhibits 11-10, 11-11, 11-13	f _{LC} - Exhibit 11-9
v _p - Flow rate	FFS - Free-flow speed	f _p - Page 11-18	TRD - Page 11-11
LOS - Level of service	BFFS - Base free-flow speed	LOS, S, FFS, v _p - Exhibits 11-2, 11-3	
DDHV - Directional design hour volume			

BASIC FREEWAY SEGMENTS WORKSHEET			
General Information		Site Information	
Analyst	BAR	Highway/Direction of Travel	I-26
Agency or Company	HNTB North Carolina, PC	From/To	I 40 to NC 191
Date Performed	7/12/2013	Jurisdiction	Buncombe County
Analysis Time Period	Peak	Analysis Year	2020 Build 8 Lanes
Project Description <i>STIP I4400/I-4700 - I-26 Widening</i>			
<input checked="" type="checkbox"/> Oper.(LOS)		<input type="checkbox"/> Des.(N)	
<input type="checkbox"/> Planning Data			
Flow Inputs			
Volume, V	5531	veh/h	Peak-Hour Factor, PHF
AADT		veh/day	0.90
Peak-Hr Prop. of AADT, K			%Trucks and Buses, P _T
Peak-Hr Direction Prop, D			6
DDHV = AADT x K x D		veh/h	%RVs, P _R
			0
			General Terrain:
			Rolling
			Grade % Length
			mi
			Up/Down %
Calculate Flow Adjustments			
f _p	1.00	E _R	2.0
E _T	2.5	f _{HV} = 1/[1+P _T (E _T - 1) + P _R (E _R - 1)]	
Speed Inputs			
Lane Width		Calc Speed Adj and FFS	
Rt-Side Lat. Clearance		f _{LW}	
Number of Lanes, N		mph	
Total Ramp Density, TRD		f _{LC}	
FFS (measured)		TRD Adjustment	
Base free-flow Speed, BFFS		mph	
65.0		FFS	
mph		65.0	
mph		mph	
LOS and Performance Measures			
Design (N)		Design (N)	
Operational (LOS)		Design (N)	
v _p = (V or DDHV) / (PHF x N x f _{HV})		Design LOS	
1675 pc/h/ln		v _p = (V or DDHV) / (PHF x N x f _{HV})	
x f _p)		pc/h/ln	
S		x f _p)	
63.9 mph		S	
D = v _p / S		mph	
26.2 pc/mi/ln		D = v _p / S	
LOS		pc/mi/ln	
D		Required Number of Lanes, N	
Glossary			
Factor Location		Factor Location	
N - Number of lanes		E _R - Exhibits 11-10, 11-12	
S - Speed		f _{LW} - Exhibit 11-8	
V - Hourly volume		E _T - Exhibits 11-10, 11-11, 11-13	
D - Density		f _{LC} - Exhibit 11-9	
FFS - Free-flow speed		f _p - Page 11-18	
BFFS - Base free-flow speed		TRD - Page 11-11	
DDHV - Directional design hour volume		LOS, S, FFS, v _p - Exhibits 11-2, 11-3	

BASIC FREEWAY SEGMENTS WORKSHEET			
General Information		Site Information	
Analyst	BAR	Highway/Direction of Travel I-26	
Agency or Company	HNTB North Carolina, PC	From/To	NC 146 to NC 280
Date Performed	7/12/2013	Jurisdiction	Buncombe County
Analysis Time Period	Peak	Analysis Year	2020 Build 8 Lanes
Project Description STIP I4400/I-4700 - I-26 Widening			
<input checked="" type="checkbox"/> Oper.(LOS)		<input type="checkbox"/> Des.(N)	
<input type="checkbox"/> Planning Data			
Flow Inputs			
Volume, V	5120	veh/h	Peak-Hour Factor, PHF 0.90
AADT		veh/day	%Trucks and Buses, P _T 5
Peak-Hr Prop. of AADT, K			%RVs, P _R 0
Peak-Hr Direction Prop, D			General Terrain: Rolling
DDHV = AADT x K x D		veh/h	Grade % Length mi
			Up/Down %
Calculate Flow Adjustments			
f _p	1.00	E _R	2.0
E _T	2.5	f _{HV} = 1/[1+P _T (E _T - 1) + P _R (E _R - 1)] 0.930	
Speed Inputs		Calc Speed Adj and FFS	
Lane Width	ft		
Rt-Side Lat. Clearance	ft	f _{LW}	mph
Number of Lanes, N	4	f _{LC}	mph
Total Ramp Density, TRD	ramps/mi	TRD Adjustment	mph
FFS (measured)	65.0	FFS	65.0
Base free-flow Speed, BFFS	mph		mph
LOS and Performance Measures		Design (N)	
<u>Operational (LOS)</u>		<u>Design (N)</u>	
v _p = (V or DDHV) / (PHF x N x f _{HV} x f _p)		Design LOS	
1529	pc/h/ln	v _p = (V or DDHV) / (PHF x N x f _{HV} x f _p)	
S	64.8	mph	pc/h/ln
D = v _p / S	23.6	pc/mi/ln	S
LOS	C	D = v _p / S	
		pc/mi/ln	
		Required Number of Lanes, N	
Glossary		Factor Location	
N - Number of lanes	S - Speed	E _R - Exhibits 11-10, 11-12	f _{LW} - Exhibit 11-8
V - Hourly volume	D - Density	E _T - Exhibits 11-10, 11-11, 11-13	f _{LC} - Exhibit 11-9
v _p - Flow rate	FFS - Free-flow speed	f _p - Page 11-18	TRD - Page 11-11
LOS - Level of service	BFFS - Base free-flow speed	LOS, S, FFS, v _p - Exhibits 11-2, 11-3	
DDHV - Directional design hour volume			

BASIC FREEWAY SEGMENTS WORKSHEET			
General Information		Site Information	
Analyst	BAR	Highway/Direction of Travel I-26	
Agency or Company	HNTB North Carolina, PC	From/To	NC 280 to US 25
Date Performed	7/12/2013	Jurisdiction	Buncombe County
Analysis Time Period	Peak	Analysis Year	2020 Build 8 Lanes
Project Description STIP I4400/I-4700 - I-26 Widening			
<input checked="" type="checkbox"/> Oper.(LOS)		<input type="checkbox"/> Des.(N)	
<input type="checkbox"/> Planning Data			
Flow Inputs			
Volume, V	4183	veh/h	Peak-Hour Factor, PHF 0.90
AADT		veh/day	%Trucks and Buses, P _T 6
Peak-Hr Prop. of AADT, K			%RVs, P _R 0
Peak-Hr Direction Prop, D			General Terrain: Rolling
DDHV = AADT x K x D		veh/h	Grade % Length mi
			Up/Down %
Calculate Flow Adjustments			
f _p	1.00	E _R	2.0
E _T	2.5	f _{HV} = 1/[1+P _T (E _T - 1) + P _R (E _R - 1)] 0.917	
Speed Inputs		Calc Speed Adj and FFS	
Lane Width	ft		
Rt-Side Lat. Clearance	ft	f _{LW}	mph
Number of Lanes, N	4	f _{LC}	mph
Total Ramp Density, TRD	ramps/mi	TRD Adjustment	mph
FFS (measured)	65.0	FFS	65.0
Base free-flow Speed, BFFS	mph		mph
LOS and Performance Measures		Design (N)	
<u>Operational (LOS)</u>		<u>Design (N)</u>	
v _p = (V or DDHV) / (PHF x N x f _{HV} x f _p)	1267 pc/h/ln	Design LOS	
S	65.0 mph	v _p = (V or DDHV) / (PHF x N x f _{HV} x f _p)	pc/h/ln
D = v _p / S	19.5 pc/mi/ln	S	mph
LOS	C	D = v _p / S	pc/mi/ln
		Required Number of Lanes, N	
Glossary		Factor Location	
N - Number of lanes	S - Speed	E _R - Exhibits 11-10, 11-12	f _{LW} - Exhibit 11-8
V - Hourly volume	D - Density	E _T - Exhibits 11-10, 11-11, 11-13	f _{LC} - Exhibit 11-9
v _p - Flow rate	FFS - Free-flow speed	f _p - Page 11-18	TRD - Page 11-11
LOS - Level of service	BFFS - Base free-flow speed	LOS, S, FFS, v _p - Exhibits 11-2, 11-3	
DDHV - Directional design hour volume			

BASIC FREEWAY SEGMENTS WORKSHEET			
General Information		Site Information	
Analyst	BAR	Highway/Direction of Travel	I-26
Agency or Company	HNTB North Carolina, PC	From/To	US 25 to US 64
Date Performed	7/12/2013	Jurisdiction	Buncombe County
Analysis Time Period	Peak	Analysis Year	2020 Build 8 Lanes
Project Description <i>STIP I4400/I-4700 - I-26 Widening</i>			
<input checked="" type="checkbox"/> Oper.(LOS)		<input type="checkbox"/> Des.(N)	
<input type="checkbox"/> Planning Data			
Flow Inputs			
Volume, V	3821	veh/h	Peak-Hour Factor, PHF
AADT		veh/day	0.90
Peak-Hr Prop. of AADT, K			%Trucks and Buses, P _T
Peak-Hr Direction Prop, D			6
DDHV = AADT x K x D		veh/h	%RVs, P _R
			0
			General Terrain:
			Rolling
			Grade % Length
			mi
			Up/Down %
Calculate Flow Adjustments			
f _p	1.00	E _R	2.0
E _T	2.5	f _{HV} = 1/[1+P _T (E _T - 1) + P _R (E _R - 1)]	
Speed Inputs			
Lane Width		Calc Speed Adj and FFS	
Rt-Side Lat. Clearance		f _{LW}	
Number of Lanes, N		mph	
Total Ramp Density, TRD		f _{LC}	
FFS (measured)		TRD Adjustment	
Base free-flow Speed, BFFS		mph	
70.0		FFS	
70.0		70.0	
70.0		70.0	
LOS and Performance Measures			
Design (N)		Design (N)	
Operational (LOS)		Design (N)	
v _p = (V or DDHV) / (PHF x N x f _{HV} x f _p)		Design LOS	
1157 pc/h/ln		v _p = (V or DDHV) / (PHF x N x f _{HV} x f _p)	
S		S	
70.0 mph		mph	
D = v _p / S		D = v _p / S	
16.5 pc/mi/ln		pc/mi/ln	
LOS		Required Number of Lanes, N	
B			
Glossary			
Factor Location		Factor Location	
N - Number of lanes		E _R - Exhibits 11-10, 11-12	
S - Speed		f _{LW} - Exhibit 11-8	
V - Hourly volume		E _T - Exhibits 11-10, 11-11, 11-13	
D - Density		f _{LC} - Exhibit 11-9	
FFS - Free-flow speed		f _p - Page 11-18	
BFFS - Base free-flow speed		TRD - Page 11-11	
DDHV - Directional design hour volume		LOS, S, FFS, v _p - Exhibits 11-2, 11-3	

BASIC FREEWAY SEGMENTS WORKSHEET			
General Information		Site Information	
Analyst	BAR	Highway/Direction of Travel	I-26
Agency or Company	HNTB North Carolina, PC	From/To	US 64 to Upward Road
Date Performed	7/12/2013	Jurisdiction	Buncombe County
Analysis Time Period	Peak	Analysis Year	2020 Build 8 Lanes
Project Description <i>STIP I4400/I-4700 - I-26 Widening</i>			
<input checked="" type="checkbox"/> Oper.(LOS)		<input type="checkbox"/> Des.(N)	
<input type="checkbox"/> Planning Data			
Flow Inputs			
Volume, V	3311	veh/h	Peak-Hour Factor, PHF
AADT		veh/day	0.90
Peak-Hr Prop. of AADT, K			%Trucks and Buses, P _T
Peak-Hr Direction Prop, D			6
DDHV = AADT x K x D		veh/h	%RVs, P _R
			0
			General Terrain:
			Rolling
			Grade % Length
			mi
			Up/Down %
Calculate Flow Adjustments			
f _p	1.00	E _R	2.0
E _T	2.5	f _{HV} = 1/[1+P _T (E _T - 1) + P _R (E _R - 1)]	0.917
Speed Inputs		Calc Speed Adj and FFS	
Lane Width	ft		
Rt-Side Lat. Clearance	ft	f _{LW}	mph
Number of Lanes, N	4	f _{LC}	mph
Total Ramp Density, TRD	ramps/mi	TRD Adjustment	mph
FFS (measured)	70.0	FFS	70.0
Base free-flow Speed, BFFS	mph		mph
LOS and Performance Measures		Design (N)	
<u>Operational (LOS)</u>		<u>Design (N)</u>	
v _p = (V or DDHV) / (PHF x N x f _{HV} x f _p)		Design LOS	
1002	pc/h/ln	v _p = (V or DDHV) / (PHF x N x f _{HV} x f _p)	
S	70.0	S	mph
D = v _p / S	14.3	D = v _p / S	pc/mi/ln
LOS	B	Required Number of Lanes, N	
Glossary		Factor Location	
N - Number of lanes	S - Speed	E _R - Exhibits 11-10, 11-12	f _{LW} - Exhibit 11-8
V - Hourly volume	D - Density	E _T - Exhibits 11-10, 11-11, 11-13	f _{LC} - Exhibit 11-9
v _p - Flow rate	FFS - Free-flow speed	f _p - Page 11-18	TRD - Page 11-11
LOS - Level of service	BFFS - Base free-flow speed	LOS, S, FFS, v _p - Exhibits 11-2, 11-3	
DDHV - Directional design hour volume			

BASIC FREEWAY SEGMENTS WORKSHEET			
General Information		Site Information	
Analyst	BAR	Highway/Direction of Travel	I-26
Agency or Company	HNTB North Carolina, PC	From/To	I-40 to NC 191
Date Performed	7/12/2013	Jurisdiction	Buncombe County
Analysis Time Period	Peak	Analysis Year	2025 Build 8 Lanes
Project Description <i>STIP I4400/I-4700 - I-26 Widening</i>			
<input checked="" type="checkbox"/> Oper.(LOS)		<input type="checkbox"/> Des.(N)	
<input type="checkbox"/> Planning Data			
Flow Inputs			
Volume, V	5734	veh/h	Peak-Hour Factor, PHF
AADT		veh/day	0.90
Peak-Hr Prop. of AADT, K			%Trucks and Buses, P _T
Peak-Hr Direction Prop, D			6
DDHV = AADT x K x D		veh/h	%RVs, P _R
			0
			General Terrain:
			Rolling
			Grade % Length
			mi
			Up/Down %
Calculate Flow Adjustments			
f _p	1.00	E _R	2.0
E _T	2.5	f _{HV} = 1/[1+P _T (E _T - 1) + P _R (E _R - 1)]	0.917
Speed Inputs		Calc Speed Adj and FFS	
Lane Width	ft		
Rt-Side Lat. Clearance	ft	f _{LW}	mph
Number of Lanes, N	4	f _{LC}	mph
Total Ramp Density, TRD	ramps/mi	TRD Adjustment	mph
FFS (measured)	65.0	FFS	65.0
Base free-flow Speed, BFFS	mph		mph
LOS and Performance Measures		Design (N)	
<u>Operational (LOS)</u>		<u>Design (N)</u>	
v _p = (V or DDHV) / (PHF x N x f _{HV})		Design LOS	
1736	pc/h/ln	v _p = (V or DDHV) / (PHF x N x f _{HV})	
x f _p)		pc/h/ln	
S	63.4	x f _p)	
S	mph	S	mph
D = v _p / S	27.4	D = v _p / S	pc/mi/ln
27.4	pc/mi/ln	Required Number of Lanes, N	
LOS	D		
Glossary		Factor Location	
N - Number of lanes	S - Speed	E _R - Exhibits 11-10, 11-12	f _{LW} - Exhibit 11-8
V - Hourly volume	D - Density	E _T - Exhibits 11-10, 11-11, 11-13	f _{LC} - Exhibit 11-9
v _p - Flow rate	FFS - Free-flow speed	f _p - Page 11-18	TRD - Page 11-11
LOS - Level of service	BFFS - Base free-flow speed	LOS, S, FFS, v _p - Exhibits 11-2, 11-3	
DDHV - Directional design hour volume			

BASIC FREEWAY SEGMENTS WORKSHEET			
General Information		Site Information	
Analyst	BAR	Highway/Direction of Travel I-26	
Agency or Company	HNTB North Carolina, PC	From/To	NC 146 to NC 280
Date Performed	7/12/2013	Jurisdiction	Buncombe County
Analysis Time Period	Peak	Analysis Year	2025 Build 8 Lanes
Project Description STIP I4400/I-4700 - I-26 Widening			
<input checked="" type="checkbox"/> Oper.(LOS)		<input type="checkbox"/> Des.(N)	
<input type="checkbox"/> Planning Data			
Flow Inputs			
Volume, V	5383	veh/h	Peak-Hour Factor, PHF 0.90
AADT		veh/day	%Trucks and Buses, P _T 5
Peak-Hr Prop. of AADT, K			%RVs, P _R 0
Peak-Hr Direction Prop, D			General Terrain: Rolling
DDHV = AADT x K x D		veh/h	Grade % Length mi
			Up/Down %
Calculate Flow Adjustments			
f _p	1.00	E _R	2.0
E _T	2.5	f _{HV} = 1/[1+P _T (E _T - 1) + P _R (E _R - 1)] 0.930	
Speed Inputs		Calc Speed Adj and FFS	
Lane Width	ft		
Rt-Side Lat. Clearance	ft	f _{LW}	mph
Number of Lanes, N	4	f _{LC}	mph
Total Ramp Density, TRD	ramps/mi	TRD Adjustment	mph
FFS (measured)	65.0	FFS	65.0
Base free-flow Speed, BFFS	mph		
LOS and Performance Measures		Design (N)	
<u>Operational (LOS)</u>		<u>Design (N)</u>	
v _p = (V or DDHV) / (PHF x N x f _{HV} x f _p)	1607 pc/h/ln	Design LOS	
S	64.4 mph	v _p = (V or DDHV) / (PHF x N x f _{HV} x f _p)	pc/h/ln
D = v _p / S	25.0 pc/mi/ln	S	mph
LOS	C	D = v _p / S	pc/mi/ln
		Required Number of Lanes, N	
Glossary		Factor Location	
N - Number of lanes	S - Speed	E _R - Exhibits 11-10, 11-12	f _{LW} - Exhibit 11-8
V - Hourly volume	D - Density	E _T - Exhibits 11-10, 11-11, 11-13	f _{LC} - Exhibit 11-9
v _p - Flow rate	FFS - Free-flow speed	f _p - Page 11-18	TRD - Page 11-11
LOS - Level of service	BFFS - Base free-flow speed	LOS, S, FFS, v _p - Exhibits 11-2, 11-3	
DDHV - Directional design hour volume			

BASIC FREEWAY SEGMENTS WORKSHEET			
General Information		Site Information	
Analyst	BAR	Highway/Direction of Travel I-26	
Agency or Company	HNTB North Carolina, PC	From/To	NC 280 to US 25
Date Performed	7/12/2013	Jurisdiction	Buncombe County
Analysis Time Period	Peak	Analysis Year	2025 Build 8 Lanes
Project Description STIP I4400/I-4700 - I-26 Widening			
<input checked="" type="checkbox"/> Oper.(LOS)		<input type="checkbox"/> Des.(N)	
<input type="checkbox"/> Planning Data			
Flow Inputs			
Volume, V	4554	veh/h	Peak-Hour Factor, PHF 0.90
AADT		veh/day	%Trucks and Buses, P _T 6
Peak-Hr Prop. of AADT, K			%RVs, P _R 0
Peak-Hr Direction Prop, D			General Terrain: Rolling
DDHV = AADT x K x D		veh/h	Grade % Length mi
			Up/Down %
Calculate Flow Adjustments			
f _p	1.00	E _R	2.0
E _T	2.5	f _{HV} = 1/[1+P _T (E _T - 1) + P _R (E _R - 1)] 0.917	
Speed Inputs		Calc Speed Adj and FFS	
Lane Width	ft		
Rt-Side Lat. Clearance	ft		
Number of Lanes, N	4		
Total Ramp Density, TRD	ramps/mi		
FFS (measured)	65.0		
Base free-flow Speed, BFFS	mph		
		f _{LW}	mph
		f _{LC}	mph
		TRD Adjustment	mph
		FFS	65.0
			mph
LOS and Performance Measures		Design (N)	
<u>Operational (LOS)</u>		<u>Design (N)</u>	
v _p = (V or DDHV) / (PHF x N x f _{HV} x f _p)		Design LOS	
1379	pc/h/ln	v _p = (V or DDHV) / (PHF x N x f _{HV} x f _p)	
S	65.0	pc/h/ln	
D = v _p / S	21.2	S	
LOS	C	mph	
		D = v _p / S	
		pc/mi/ln	
		Required Number of Lanes, N	
Glossary		Factor Location	
N - Number of lanes	S - Speed	E _R - Exhibits 11-10, 11-12	f _{LW} - Exhibit 11-8
V - Hourly volume	D - Density	E _T - Exhibits 11-10, 11-11, 11-13	f _{LC} - Exhibit 11-9
v _p - Flow rate	FFS - Free-flow speed	f _p - Page 11-18	TRD - Page 11-11
LOS - Level of service	BFFS - Base free-flow speed	LOS, S, FFS, v _p - Exhibits 11-2, 11-3	
DDHV - Directional design hour volume			

BASIC FREEWAY SEGMENTS WORKSHEET			
General Information		Site Information	
Analyst	BAR	Highway/Direction of Travel	I-26
Agency or Company	HNTB North Carolina, PC	From/To	US 25 to US 64
Date Performed	7/12/2013	Jurisdiction	Buncombe County
Analysis Time Period	Peak	Analysis Year	2025 Build 8 Lanes
Project Description <i>STIP I4400/I-4700 - I-26 Widening</i>			
<input checked="" type="checkbox"/> Oper.(LOS)		<input type="checkbox"/> Des.(N)	
<input type="checkbox"/> Planning Data			
Flow Inputs			
Volume, V	4193	veh/h	Peak-Hour Factor, PHF
AADT		veh/day	0.90
Peak-Hr Prop. of AADT, K			%Trucks and Buses, P _T
Peak-Hr Direction Prop, D			6
DDHV = AADT x K x D		veh/h	%RVs, P _R
			0
			General Terrain:
			Rolling
			Grade % Length
			mi
			Up/Down %
Calculate Flow Adjustments			
f _p	1.00	E _R	2.0
E _T	2.5	f _{HV} = 1/[1+P _T (E _T - 1) + P _R (E _R - 1)]	
Speed Inputs		Calc Speed Adj and FFS	
Lane Width	ft		
Rt-Side Lat. Clearance	ft	f _{LW}	mph
Number of Lanes, N	4	f _{LC}	mph
Total Ramp Density, TRD	ramps/mi	TRD Adjustment	mph
FFS (measured)	70.0	FFS	70.0
Base free-flow Speed, BFFS	mph		mph
LOS and Performance Measures		Design (N)	
<u>Operational (LOS)</u>		<u>Design (N)</u>	
v _p = (V or DDHV) / (PHF x N x f _{HV} x f _p)		Design LOS	
1270	pc/h/ln	v _p = (V or DDHV) / (PHF x N x f _{HV} x f _p)	
S	69.9	mph	pc/h/ln
D = v _p / S	18.2	pc/mi/ln	S
LOS	C		mph
			pc/mi/ln
			D = v _p / S
			Required Number of Lanes, N
Glossary		Factor Location	
N - Number of lanes	S - Speed	E _R - Exhibits 11-10, 11-12	f _{LW} - Exhibit 11-8
V - Hourly volume	D - Density	E _T - Exhibits 11-10, 11-11, 11-13	f _{LC} - Exhibit 11-9
v _p - Flow rate	FFS - Free-flow speed	f _p - Page 11-18	TRD - Page 11-11
LOS - Level of service	BFFS - Base free-flow speed	LOS, S, FFS, v _p - Exhibits 11-2, 11-3	
DDHV - Directional design hour volume			

BASIC FREEWAY SEGMENTS WORKSHEET			
General Information		Site Information	
Analyst	BAR	Highway/Direction of Travel	I-26
Agency or Company	HNTB North Carolina, PC	From/To	US 64 to Upward Road
Date Performed	7/12/2013	Jurisdiction	Buncombe County
Analysis Time Period	Peak	Analysis Year	2025 Build 8 Lanes
Project Description <i>STIP I4400/I-4700 - I-26 Widening</i>			
<input checked="" type="checkbox"/> Oper.(LOS)		<input type="checkbox"/> Des.(N)	
<input type="checkbox"/> Planning Data			
Flow Inputs			
Volume, V	3651	veh/h	Peak-Hour Factor, PHF
AADT		veh/day	0.90
Peak-Hr Prop. of AADT, K			%Trucks and Buses, P _T
Peak-Hr Direction Prop, D			6
DDHV = AADT x K x D		veh/h	%RVs, P _R
			0
			General Terrain:
			Rolling
			Grade % Length
			mi
			Up/Down %
Calculate Flow Adjustments			
f _p	1.00	E _R	2.0
E _T	2.5	f _{HV} = 1/[1+P _T (E _T - 1) + P _R (E _R - 1)]	0.917
Speed Inputs		Calc Speed Adj and FFS	
Lane Width	ft		
Rt-Side Lat. Clearance	ft	f _{LW}	mph
Number of Lanes, N	4	f _{LC}	mph
Total Ramp Density, TRD	ramps/mi	TRD Adjustment	mph
FFS (measured)	70.0	FFS	70.0
Base free-flow Speed, BFFS	mph		mph
LOS and Performance Measures		Design (N)	
<u>Operational (LOS)</u>		<u>Design (N)</u>	
v _p = (V or DDHV) / (PHF x N x f _{HV} x f _p)		Design LOS	
1105	pc/h/ln	v _p = (V or DDHV) / (PHF x N x f _{HV} x f _p)	
S	70.0	S	mph
D = v _p / S	15.8	D = v _p / S	pc/mi/ln
LOS	B	Required Number of Lanes, N	
Glossary		Factor Location	
N - Number of lanes	S - Speed	E _R - Exhibits 11-10, 11-12	f _{LW} - Exhibit 11-8
V - Hourly volume	D - Density	E _T - Exhibits 11-10, 11-11, 11-13	f _{LC} - Exhibit 11-9
v _p - Flow rate	FFS - Free-flow speed	f _p - Page 11-18	TRD - Page 11-11
LOS - Level of service	BFFS - Base free-flow speed	LOS, S, FFS, v _p - Exhibits 11-2, 11-3	
DDHV - Directional design hour volume			

BASIC FREEWAY SEGMENTS WORKSHEET			
General Information		Site Information	
Analyst	BAR	Highway/Direction of Travel	I-26
Agency or Company	HNTB North Carolina, PC	From/To	I 40 to NC 191
Date Performed	7/12/2013	Jurisdiction	Buncombe County
Analysis Time Period	Peak	Analysis Year	2030 Build 8 Lanes
Project Description STIP I4400/I-4700 - I-26 Widening			
<input checked="" type="checkbox"/> Oper.(LOS)		<input type="checkbox"/> Des.(N)	<input type="checkbox"/> Planning Data
Flow Inputs			
Volume, V	5937	veh/h	Peak-Hour Factor, PHF 0.90
AADT		veh/day	%Trucks and Buses, P _T 6
Peak-Hr Prop. of AADT, K			%RVs, P _R 0
Peak-Hr Direction Prop, D			General Terrain: Rolling
DDHV = AADT x K x D		veh/h	Grade % Length mi
			Up/Down %
Calculate Flow Adjustments			
f _p	1.00	E _R	2.0
E _T	2.5	f _{HV} = 1/[1+P _T (E _T - 1) + P _R (E _R - 1)]	0.917
Speed Inputs		Calc Speed Adj and FFS	
Lane Width		ft	
Rt-Side Lat. Clearance		ft	f _{LW} mph
Number of Lanes, N	4		f _{LC} mph
Total Ramp Density, TRD		ramps/mi	TRD Adjustment mph
FFS (measured)	65.0	mph	FFS 65.0 mph
Base free-flow Speed, BFFS		mph	
LOS and Performance Measures		Design (N)	
<u>Operational (LOS)</u>		<u>Design (N)</u>	
v _p = (V or DDHV) / (PHF x N x f _{HV})		Design LOS	
	1798	pc/h/ln	v _p = (V or DDHV) / (PHF x N x f _{HV})
			x f _p)
S	62.8	mph	S
D = v _p / S	28.7	pc/mi/ln	D = v _p / S
LOS	D		Required Number of Lanes, N
Glossary		Factor Location	
N - Number of lanes	S - Speed	E _R - Exhibits 11-10, 11-12	f _{LW} - Exhibit 11-8
V - Hourly volume	D - Density	E _T - Exhibits 11-10, 11-11, 11-13	f _{LC} - Exhibit 11-9
v _p - Flow rate	FFS - Free-flow speed	f _p - Page 11-18	TRD - Page 11-11
LOS - Level of service	BFFS - Base free-flow speed	LOS, S, FFS, v _p - Exhibits 11-2, 11-3	
DDHV - Directional design hour volume			

BASIC FREEWAY SEGMENTS WORKSHEET			
General Information		Site Information	
Analyst	BAR	Highway/Direction of Travel I-26	
Agency or Company	HNTB North Carolina, PC	From/To	NC 146 to NC 280
Date Performed	7/12/2013	Jurisdiction	Buncombe County
Analysis Time Period	Peak	Analysis Year	2030 Build 8 Lanes
Project Description STIP I4400/I-4700 - I-26 Widening			
<input checked="" type="checkbox"/> Oper.(LOS)		<input type="checkbox"/> Des.(N)	
<input type="checkbox"/> Planning Data			
Flow Inputs			
Volume, V	5647	veh/h	Peak-Hour Factor, PHF 0.90
AADT		veh/day	%Trucks and Buses, P _T 5
Peak-Hr Prop. of AADT, K			%RVs, P _R 0
Peak-Hr Direction Prop, D			General Terrain: Rolling
DDHV = AADT x K x D		veh/h	Grade % Length mi
			Up/Down %
Calculate Flow Adjustments			
f _p	1.00	E _R	2.0
E _T	2.5	f _{HV} = 1/[1+P _T (E _T - 1) + P _R (E _R - 1)] 0.930	
Speed Inputs		Calc Speed Adj and FFS	
Lane Width	ft		
Rt-Side Lat. Clearance	ft	f _{LW}	mph
Number of Lanes, N	4	f _{LC}	mph
Total Ramp Density, TRD	ramps/mi	TRD Adjustment	mph
FFS (measured)	65.0	FFS	65.0
Base free-flow Speed, BFFS	mph		
LOS and Performance Measures		Design (N)	
<u>Operational (LOS)</u>		<u>Design (N)</u>	
v _p = (V or DDHV) / (PHF x N x f _{HV} x f _p)	1686 pc/h/ln	Design LOS	
S	63.8 mph	v _p = (V or DDHV) / (PHF x N x f _{HV} x f _p)	pc/h/ln
D = v _p / S	26.4 pc/mi/ln	S	mph
LOS	D	D = v _p / S	pc/mi/ln
		Required Number of Lanes, N	
Glossary		Factor Location	
N - Number of lanes	S - Speed	E _R - Exhibits 11-10, 11-12	f _{LW} - Exhibit 11-8
V - Hourly volume	D - Density	E _T - Exhibits 11-10, 11-11, 11-13	f _{LC} - Exhibit 11-9
v _p - Flow rate	FFS - Free-flow speed	f _p - Page 11-18	TRD - Page 11-11
LOS - Level of service	BFFS - Base free-flow speed	LOS, S, FFS, v _p - Exhibits 11-2, 11-3	
DDHV - Directional design hour volume			

BASIC FREEWAY SEGMENTS WORKSHEET			
General Information		Site Information	
Analyst	BAR	Highway/Direction of Travel I-26	
Agency or Company	HNTB North Carolina, PC	From/To	NC 280 to US 25
Date Performed	7/12/2013	Jurisdiction	Buncombe County
Analysis Time Period	Peak	Analysis Year	2030 Build 8 Lanes
Project Description STIP I4400/I-4700 - I-26 Widening			
<input checked="" type="checkbox"/> Oper.(LOS)		<input type="checkbox"/> Des.(N)	
<input type="checkbox"/> Planning Data			
Flow Inputs			
Volume, V	4925	veh/h	Peak-Hour Factor, PHF 0.90
AADT		veh/day	%Trucks and Buses, P _T 6
Peak-Hr Prop. of AADT, K			%RVs, P _R 0
Peak-Hr Direction Prop, D			General Terrain: Rolling
DDHV = AADT x K x D		veh/h	Grade % Length mi
			Up/Down %
Calculate Flow Adjustments			
f _p	1.00	E _R	2.0
E _T	2.5	f _{HV} = 1/[1+P _T (E _T - 1) + P _R (E _R - 1)] 0.917	
Speed Inputs		Calc Speed Adj and FFS	
Lane Width	ft		
Rt-Side Lat. Clearance	ft	f _{LW}	mph
Number of Lanes, N	4	f _{LC}	mph
Total Ramp Density, TRD	ramps/mi	TRD Adjustment	mph
FFS (measured)	65.0	FFS	65.0
Base free-flow Speed, BFFS	mph		mph
LOS and Performance Measures		Design (N)	
<u>Operational (LOS)</u>		<u>Design (N)</u>	
v _p = (V or DDHV) / (PHF x N x f _{HV} x f _p)	1491 pc/h/ln	Design LOS	
S	64.9 mph	v _p = (V or DDHV) / (PHF x N x f _{HV} x f _p)	pc/h/ln
D = v _p / S	23.0 pc/mi/ln	S	mph
LOS	C	D = v _p / S	pc/mi/ln
		Required Number of Lanes, N	
Glossary		Factor Location	
N - Number of lanes	S - Speed	E _R - Exhibits 11-10, 11-12	f _{LW} - Exhibit 11-8
V - Hourly volume	D - Density	E _T - Exhibits 11-10, 11-11, 11-13	f _{LC} - Exhibit 11-9
v _p - Flow rate	FFS - Free-flow speed	f _p - Page 11-18	TRD - Page 11-11
LOS - Level of service	BFFS - Base free-flow speed	LOS, S, FFS, v _p - Exhibits 11-2, 11-3	
DDHV - Directional design hour volume			

BASIC FREEWAY SEGMENTS WORKSHEET			
General Information		Site Information	
Analyst	BAR	Highway/Direction of Travel	I-26
Agency or Company	HNTB North Carolina, PC	From/To	US 25 to US 64
Date Performed	7/12/2013	Jurisdiction	Buncombe County
Analysis Time Period	Peak	Analysis Year	2030 Build 8 Lanes
Project Description <i>STIP I4400/I-4700 - I-26 Widening</i>			
<input checked="" type="checkbox"/> Oper.(LOS)		<input type="checkbox"/> Des.(N)	
<input type="checkbox"/> Planning Data			
Flow Inputs			
Volume, V	4565	veh/h	Peak-Hour Factor, PHF
AADT		veh/day	0.90
Peak-Hr Prop. of AADT, K			%Trucks and Buses, P _T
Peak-Hr Direction Prop, D			6
DDHV = AADT x K x D		veh/h	%RVs, P _R
			0
			General Terrain:
			Rolling
			Grade % Length
			mi
			Up/Down %
Calculate Flow Adjustments			
f _p	1.00	E _R	2.0
E _T	2.5	f _{HV} = 1/[1+P _T (E _T - 1) + P _R (E _R - 1)]	
Speed Inputs		Calc Speed Adj and FFS	
Lane Width	ft		
Rt-Side Lat. Clearance	ft	f _{LW}	mph
Number of Lanes, N	4	f _{LC}	mph
Total Ramp Density, TRD	ramps/mi	TRD Adjustment	mph
FFS (measured)	70.0	FFS	70.0
Base free-flow Speed, BFFS	mph		mph
LOS and Performance Measures		Design (N)	
<u>Operational (LOS)</u>		<u>Design (N)</u>	
v _p = (V or DDHV) / (PHF x N x f _{HV} x f _p)		Design LOS	
1382	pc/h/ln	v _p = (V or DDHV) / (PHF x N x f _{HV} x f _p)	
S	69.6	mph	pc/h/ln
D = v _p / S	19.9	pc/mi/ln	S
LOS	C		mph
			pc/mi/ln
			D = v _p / S
			pc/mi/ln
			Required Number of Lanes, N
Glossary		Factor Location	
N - Number of lanes	S - Speed	E _R - Exhibits 11-10, 11-12	f _{LW} - Exhibit 11-8
V - Hourly volume	D - Density	E _T - Exhibits 11-10, 11-11, 11-13	f _{LC} - Exhibit 11-9
v _p - Flow rate	FFS - Free-flow speed	f _p - Page 11-18	TRD - Page 11-11
LOS - Level of service	BFFS - Base free-flow speed	LOS, S, FFS, v _p - Exhibits 11-2, 11-3	
DDHV - Directional design hour volume			

BASIC FREEWAY SEGMENTS WORKSHEET			
General Information		Site Information	
Analyst	BAR	Highway/Direction of Travel	I-26
Agency or Company	HNTB North Carolina, PC	From/To	US 64 to Upward Road
Date Performed	7/12/2013	Jurisdiction	Buncombe County
Analysis Time Period	Peak	Analysis Year	2030 Build 8 Lanes
Project Description <i>STIP I4400/I-4700 - I-26 Widening</i>			
<input checked="" type="checkbox"/> Oper.(LOS)		<input type="checkbox"/> Des.(N)	
<input type="checkbox"/> Planning Data			
Flow Inputs			
Volume, V	3992	veh/h	Peak-Hour Factor, PHF
AADT		veh/day	0.90
Peak-Hr Prop. of AADT, K			%Trucks and Buses, P _T
Peak-Hr Direction Prop, D			6
DDHV = AADT x K x D		veh/h	%RVs, P _R
			0
			General Terrain:
			Rolling
			Grade % Length
			mi
			Up/Down %
Calculate Flow Adjustments			
f _p	1.00	E _R	2.0
E _T	2.5	f _{HV} = 1/[1+P _T (E _T - 1) + P _R (E _R - 1)]	
Speed Inputs		Calc Speed Adj and FFS	
Lane Width	ft		
Rt-Side Lat. Clearance	ft	f _{LW}	mph
Number of Lanes, N	4	f _{LC}	mph
Total Ramp Density, TRD	ramps/mi	TRD Adjustment	mph
FFS (measured)	70.0	FFS	70.0
Base free-flow Speed, BFFS	mph		
LOS and Performance Measures		Design (N)	
<u>Operational (LOS)</u>		<u>Design (N)</u>	
v _p = (V or DDHV) / (PHF x N x f _{HV} x f _p)		Design LOS	
1209	pc/h/ln	v _p = (V or DDHV) / (PHF x N x f _{HV} x f _p)	
S	70.0	S	mph
D = v _p / S	17.3	D = v _p / S	pc/mi/ln
LOS	B	Required Number of Lanes, N	
Glossary		Factor Location	
N - Number of lanes	S - Speed	E _R - Exhibits 11-10, 11-12	f _{LW} - Exhibit 11-8
V - Hourly volume	D - Density	E _T - Exhibits 11-10, 11-11, 11-13	f _{LC} - Exhibit 11-9
v _p - Flow rate	FFS - Free-flow speed	f _p - Page 11-18	TRD - Page 11-11
LOS - Level of service	BFFS - Base free-flow speed	LOS, S, FFS, v _p - Exhibits 11-2, 11-3	
DDHV - Directional design hour volume			

BASIC FREEWAY SEGMENTS WORKSHEET			
General Information		Site Information	
Analyst	BAR	Highway/Direction of Travel I-26	
Agency or Company	HNTB North Carolina, PC	From/To	I-40 to NC 191
Date Performed	7/12/2013	Jurisdiction	Buncombe County
Analysis Time Period	Peak	Analysis Year	2035 Build 8 Lanes
Project Description STIP I4400/I-4700 - I-26 Widening			
<input checked="" type="checkbox"/> Oper.(LOS)		<input type="checkbox"/> Des.(N)	
<input type="checkbox"/> Planning Data			
Flow Inputs			
Volume, V	6140	veh/h	Peak-Hour Factor, PHF 0.90
AADT		veh/day	%Trucks and Buses, P _T 6
Peak-Hr Prop. of AADT, K			%RVs, P _R 0
Peak-Hr Direction Prop, D			General Terrain: Rolling
DDHV = AADT x K x D		veh/h	Grade % Length mi
			Up/Down %
Calculate Flow Adjustments			
f _p	1.00	E _R	2.0
E _T	2.5	f _{HV} = 1/[1+P _T (E _T - 1) + P _R (E _R - 1)] 0.917	
Speed Inputs		Calc Speed Adj and FFS	
Lane Width	ft		
Rt-Side Lat. Clearance	ft	f _{LW}	mph
Number of Lanes, N	4	f _{LC}	mph
Total Ramp Density, TRD	ramps/mi	TRD Adjustment	mph
FFS (measured)	65.0	FFS	65.0
Base free-flow Speed, BFFS	mph		mph
LOS and Performance Measures		Design (N)	
<u>Operational (LOS)</u>		<u>Design (N)</u>	
v _p = (V or DDHV) / (PHF x N x f _{HV} x f _p)	1859 pc/h/ln	Design LOS	
S	62.0 mph	v _p = (V or DDHV) / (PHF x N x f _{HV} x f _p)	pc/h/ln
D = v _p / S	30.0 pc/mi/ln	S	mph
LOS	D	D = v _p / S	pc/mi/ln
		Required Number of Lanes, N	
Glossary		Factor Location	
N - Number of lanes	S - Speed	E _R - Exhibits 11-10, 11-12	f _{LW} - Exhibit 11-8
V - Hourly volume	D - Density	E _T - Exhibits 11-10, 11-11, 11-13	f _{LC} - Exhibit 11-9
v _p - Flow rate	FFS - Free-flow speed	f _p - Page 11-18	TRD - Page 11-11
LOS - Level of service	BFFS - Base free-flow speed	LOS, S, FFS, v _p - Exhibits 11-2, 11-3	
DDHV - Directional design hour volume			

BASIC FREEWAY SEGMENTS WORKSHEET			
General Information		Site Information	
Analyst	BAR	Highway/Direction of Travel	I-26
Agency or Company	HNTB North Carolina, PC	From/To	NC 146 to NC 280
Date Performed	7/12/2013	Jurisdiction	Buncombe County
Analysis Time Period	Peak	Analysis Year	2035 Build 8 Lanes
Project Description <i>STIP I4400/I-4700 - I-26 Widening</i>			
<input checked="" type="checkbox"/> Oper.(LOS)		<input type="checkbox"/> Des.(N)	
<input type="checkbox"/> Planning Data			
Flow Inputs			
Volume, V	5910	veh/h	Peak-Hour Factor, PHF
AADT		veh/day	0.90
Peak-Hr Prop. of AADT, K			%Trucks and Buses, P _T
Peak-Hr Direction Prop, D			5
DDHV = AADT x K x D		veh/h	%RVs, P _R
			0
			General Terrain:
			Rolling
			Grade % Length
			mi
			Up/Down %
Calculate Flow Adjustments			
f _p	1.00	E _R	2.0
E _T	2.5	f _{HV} = 1/[1+P _T (E _T - 1) + P _R (E _R - 1)]	0.930
Speed Inputs		Calc Speed Adj and FFS	
Lane Width	ft		
Rt-Side Lat. Clearance	ft	f _{LW}	mph
Number of Lanes, N	4	f _{LC}	mph
Total Ramp Density, TRD	ramps/mi	TRD Adjustment	mph
FFS (measured)	65.0	FFS	65.0
Base free-flow Speed, BFFS	mph		mph
LOS and Performance Measures		Design (N)	
<u>Operational (LOS)</u>		<u>Design (N)</u>	
v _p = (V or DDHV) / (PHF x N x f _{HV} x f _p)	1765 pc/h/ln	Design LOS	
S	63.1 mph	v _p = (V or DDHV) / (PHF x N x f _{HV} x f _p)	pc/h/ln
D = v _p / S	28.0 pc/mi/ln	S	mph
LOS	D	D = v _p / S	pc/mi/ln
		Required Number of Lanes, N	
Glossary		Factor Location	
N - Number of lanes	S - Speed	E _R - Exhibits 11-10, 11-12	f _{LW} - Exhibit 11-8
V - Hourly volume	D - Density	E _T - Exhibits 11-10, 11-11, 11-13	f _{LC} - Exhibit 11-9
v _p - Flow rate	FFS - Free-flow speed	f _p - Page 11-18	TRD - Page 11-11
LOS - Level of service speed	BFFS - Base free-flow speed	LOS, S, FFS, v _p - Exhibits 11-2, 11-3	
DDHV - Directional design hour volume			

BASIC FREEWAY SEGMENTS WORKSHEET			
General Information		Site Information	
Analyst	BAR	Highway/Direction of Travel	I-26
Agency or Company	HNTB North Carolina, PC	From/To	NC 280 to US 25
Date Performed	7/12/2013	Jurisdiction	Buncombe County
Analysis Time Period	Peak	Analysis Year	2035 Build 8 Lanes
Project Description <i>STIP I4400/I-4700 - I-26 Widening</i>			
<input checked="" type="checkbox"/> Oper.(LOS)		<input type="checkbox"/> Des.(N)	
<input type="checkbox"/> Planning Data			
Flow Inputs			
Volume, V	5295	veh/h	Peak-Hour Factor, PHF
AADT		veh/day	0.90
Peak-Hr Prop. of AADT, K			%Trucks and Buses, P _T
Peak-Hr Direction Prop, D			6
DDHV = AADT x K x D		veh/h	%RVs, P _R
			0
			General Terrain:
			Rolling
			Grade % Length
			mi
			Up/Down %
Calculate Flow Adjustments			
f _p	1.00	E _R	2.0
E _T	2.5	f _{HV} = 1/[1+P _T (E _T - 1) + P _R (E _R - 1)]	
Speed Inputs		Calc Speed Adj and FFS	
Lane Width	ft		
Rt-Side Lat. Clearance	ft	f _{LW}	mph
Number of Lanes, N	4	f _{LC}	mph
Total Ramp Density, TRD	ramps/mi	TRD Adjustment	mph
FFS (measured)	65.0	FFS	65.0
Base free-flow Speed, BFFS	mph		
LOS and Performance Measures		Design (N)	
<u>Operational (LOS)</u>		<u>Design (N)</u>	
v _p = (V or DDHV) / (PHF x N x f _{HV} x f _p)		Design LOS	
1603	pc/h/ln	v _p = (V or DDHV) / (PHF x N x f _{HV} x f _p)	
S	64.4	pc/h/ln	
D = v _p / S	24.9	S	
LOS	C	mph	
		D = v _p / S	
		pc/mi/ln	
		Required Number of Lanes, N	
Glossary		Factor Location	
N - Number of lanes	S - Speed	E _R - Exhibits 11-10, 11-12	f _{LW} - Exhibit 11-8
V - Hourly volume	D - Density	E _T - Exhibits 11-10, 11-11, 11-13	f _{LC} - Exhibit 11-9
v _p - Flow rate	FFS - Free-flow speed	f _p - Page 11-18	TRD - Page 11-11
LOS - Level of service	BFFS - Base free-flow speed	LOS, S, FFS, v _p - Exhibits 11-2, 11-3	
DDHV - Directional design hour volume			

BASIC FREEWAY SEGMENTS WORKSHEET			
General Information		Site Information	
Analyst	BAR	Highway/Direction of Travel	I-26
Agency or Company	HNTB North Carolina, PC	From/To	US 25 to US 64
Date Performed	7/12/2013	Jurisdiction	Buncombe County
Analysis Time Period	Peak	Analysis Year	2035 Build 8 Lanes
Project Description <i>STIP I4400/I-4700 - I-26 Widening</i>			
<input checked="" type="checkbox"/> Oper.(LOS)		<input type="checkbox"/> Des.(N)	
<input type="checkbox"/> Planning Data			
Flow Inputs			
Volume, V	4937	veh/h	Peak-Hour Factor, PHF
AADT		veh/day	0.90
Peak-Hr Prop. of AADT, K			%Trucks and Buses, P _T
Peak-Hr Direction Prop, D			6
DDHV = AADT x K x D		veh/h	%RVs, P _R
			0
			General Terrain:
			Rolling
			Grade % Length
			mi
			Up/Down %
Calculate Flow Adjustments			
f _p	1.00	E _R	2.0
E _T	2.5	f _{HV} = 1/[1+P _T (E _T - 1) + P _R (E _R - 1)]	0.917
Speed Inputs		Calc Speed Adj and FFS	
Lane Width	ft		
Rt-Side Lat. Clearance	ft	f _{LW}	mph
Number of Lanes, N	4	f _{LC}	mph
Total Ramp Density, TRD	ramps/mi	TRD Adjustment	mph
FFS (measured)	70.0	FFS	70.0
Base free-flow Speed, BFFS	mph		mph
LOS and Performance Measures		Design (N)	
<u>Operational (LOS)</u>		<u>Design (N)</u>	
v _p = (V or DDHV) / (PHF x N x f _{HV} x f _p)	1495	Design LOS	
S	69.0	v _p = (V or DDHV) / (PHF x N x f _{HV} x f _p)	pc/h/ln
D = v _p / S	21.7	S	mph
LOS	C	D = v _p / S	pc/mi/ln
		Required Number of Lanes, N	
Glossary		Factor Location	
N - Number of lanes	S - Speed	E _R - Exhibits 11-10, 11-12	f _{LW} - Exhibit 11-8
V - Hourly volume	D - Density	E _T - Exhibits 11-10, 11-11, 11-13	f _{LC} - Exhibit 11-9
v _p - Flow rate	FFS - Free-flow speed	f _p - Page 11-18	TRD - Page 11-11
LOS - Level of service	BFFS - Base free-flow speed	LOS, S, FFS, v _p - Exhibits 11-2, 11-3	
DDHV - Directional design hour volume			

BASIC FREEWAY SEGMENTS WORKSHEET			
General Information		Site Information	
Analyst	BAR	Highway/Direction of Travel	I-26
Agency or Company	HNTB North Carolina, PC	From/To	US 64 to Upward Road
Date Performed	7/12/2013	Jurisdiction	Buncombe County
Analysis Time Period	Peak	Analysis Year	2035 Build 8 Lanes
Project Description <i>STIP I4400/I-4700 - I-26 Widening</i>			
<input checked="" type="checkbox"/> Oper.(LOS)		<input type="checkbox"/> Des.(N)	
<input type="checkbox"/> Planning Data			
Flow Inputs			
Volume, V	4332	veh/h	Peak-Hour Factor, PHF
AADT		veh/day	0.90
Peak-Hr Prop. of AADT, K			%Trucks and Buses, P _T
Peak-Hr Direction Prop, D			6
DDHV = AADT x K x D		veh/h	%RVs, P _R
			0
			General Terrain:
			Rolling
			Grade % Length
			mi
			Up/Down %
Calculate Flow Adjustments			
f _p	1.00	E _R	2.0
E _T	2.5	f _{HV} = 1/[1+P _T (E _T - 1) + P _R (E _R - 1)]	
Speed Inputs		Calc Speed Adj and FFS	
Lane Width	ft		
Rt-Side Lat. Clearance	ft	f _{LW}	mph
Number of Lanes, N	4	f _{LC}	mph
Total Ramp Density, TRD	ramps/mi	TRD Adjustment	mph
FFS (measured)	70.0	FFS	70.0
Base free-flow Speed, BFFS	mph		
LOS and Performance Measures		Design (N)	
<u>Operational (LOS)</u>		<u>Design (N)</u>	
v _p = (V or DDHV) / (PHF x N x f _{HV} x f _p)		Design LOS	
1312	pc/h/ln	v _p = (V or DDHV) / (PHF x N x f _{HV} x f _p)	
S	69.9	pc/h/ln	
D = v _p / S	18.8	S	
LOS	C	mph	
		D = v _p / S	
		pc/mi/ln	
		Required Number of Lanes, N	
Glossary		Factor Location	
N - Number of lanes	S - Speed	E _R - Exhibits 11-10, 11-12	f _{LW} - Exhibit 11-8
V - Hourly volume	D - Density	E _T - Exhibits 11-10, 11-11, 11-13	f _{LC} - Exhibit 11-9
v _p - Flow rate	FFS - Free-flow speed	f _p - Page 11-18	TRD - Page 11-11
LOS - Level of service	BFFS - Base free-flow speed	LOS, S, FFS, v _p - Exhibits 11-2, 11-3	
DDHV - Directional design hour volume			

BASIC FREEWAY SEGMENTS WORKSHEET			
General Information		Site Information	
Analyst	BAR	Highway/Direction of Travel	I-26
Agency or Company	HNTB North Carolina, PC	From/To	I 40 to NC 191
Date Performed	7/12/2013	Jurisdiction	Buncombe County
Analysis Time Period	Peak	Analysis Year	2040 Build 8 Lanes
Project Description <i>STIP I4400/I-4700 - I-26 Widening</i>			
<input checked="" type="checkbox"/> Oper.(LOS)		<input type="checkbox"/> Des.(N)	
<input type="checkbox"/> Planning Data			
Flow Inputs			
Volume, V	6343	veh/h	Peak-Hour Factor, PHF
AADT		veh/day	0.90
Peak-Hr Prop. of AADT, K			%Trucks and Buses, P _T
Peak-Hr Direction Prop, D			6
DDHV = AADT x K x D		veh/h	%RVs, P _R
			0
			General Terrain:
			Rolling
			Grade % Length
			mi
			Up/Down %
Calculate Flow Adjustments			
f _p	1.00	E _R	2.0
E _T	2.5	f _{HV} = 1/[1+P _T (E _T - 1) + P _R (E _R - 1)]	0.917
Speed Inputs		Calc Speed Adj and FFS	
Lane Width	ft		
Rt-Side Lat. Clearance	ft	f _{LW}	mph
Number of Lanes, N	4	f _{LC}	mph
Total Ramp Density, TRD	ramps/mi	TRD Adjustment	mph
FFS (measured)	65.0	FFS	65.0
Base free-flow Speed, BFFS	mph		mph
LOS and Performance Measures		Design (N)	
<u>Operational (LOS)</u>		<u>Design (N)</u>	
v _p = (V or DDHV) / (PHF x N x f _{HV} x f _p)	1921	Design LOS	
S	61.2	v _p = (V or DDHV) / (PHF x N x f _{HV} x f _p)	pc/h/ln
D = v _p / S	31.4	S	mph
LOS	D	D = v _p / S	pc/mi/ln
		Required Number of Lanes, N	
Glossary		Factor Location	
N - Number of lanes	S - Speed	E _R - Exhibits 11-10, 11-12	f _{LW} - Exhibit 11-8
V - Hourly volume	D - Density	E _T - Exhibits 11-10, 11-11, 11-13	f _{LC} - Exhibit 11-9
v _p - Flow rate	FFS - Free-flow speed	f _p - Page 11-18	TRD - Page 11-11
LOS - Level of service	BFFS - Base free-flow speed	LOS, S, FFS, v _p - Exhibits 11-2, 11-3	
DDHV - Directional design hour volume			

BASIC FREEWAY SEGMENTS WORKSHEET			
General Information		Site Information	
Analyst	BAR	Highway/Direction of Travel I-26	
Agency or Company	HNTB North Carolina, PC	From/To	NC 146 to NC 280
Date Performed	7/12/2013	Jurisdiction	Buncombe County
Analysis Time Period	Peak	Analysis Year	2040 Build 8 Lanes
Project Description STIP I4400/I-4700 - I-26 Widening			
<input checked="" type="checkbox"/> Oper.(LOS)		<input type="checkbox"/> Des.(N)	
<input type="checkbox"/> Planning Data			
Flow Inputs			
Volume, V	6174	veh/h	Peak-Hour Factor, PHF 0.90
AADT		veh/day	%Trucks and Buses, P _T 5
Peak-Hr Prop. of AADT, K			%RVs, P _R 0
Peak-Hr Direction Prop, D			General Terrain: Rolling
DDHV = AADT x K x D		veh/h	Grade % Length mi
			Up/Down %
Calculate Flow Adjustments			
f _p	1.00	E _R	2.0
E _T	2.5	f _{HV} = 1/[1+P _T (E _T - 1) + P _R (E _R - 1)] 0.930	
Speed Inputs		Calc Speed Adj and FFS	
Lane Width	ft		
Rt-Side Lat. Clearance	ft	f _{LW}	mph
Number of Lanes, N	4	f _{LC}	mph
Total Ramp Density, TRD	ramps/mi	TRD Adjustment	mph
FFS (measured)	65.0	FFS	65.0
Base free-flow Speed, BFFS	mph		mph
LOS and Performance Measures		Design (N)	
<u>Operational (LOS)</u>		<u>Design (N)</u>	
v _p = (V or DDHV) / (PHF x N x f _{HV} x f _p)	1844 pc/h/ln	Design LOS	
S	62.2 mph	v _p = (V or DDHV) / (PHF x N x f _{HV} x f _p)	pc/h/ln
D = v _p / S	29.6 pc/mi/ln	S	mph
LOS	D	D = v _p / S	pc/mi/ln
		Required Number of Lanes, N	
Glossary		Factor Location	
N - Number of lanes	S - Speed	E _R - Exhibits 11-10, 11-12	f _{LW} - Exhibit 11-8
V - Hourly volume	D - Density	E _T - Exhibits 11-10, 11-11, 11-13	f _{LC} - Exhibit 11-9
v _p - Flow rate	FFS - Free-flow speed	f _p - Page 11-18	TRD - Page 11-11
LOS - Level of service	BFFS - Base free-flow speed	LOS, S, FFS, v _p - Exhibits 11-2, 11-3	
DDHV - Directional design hour volume			

BASIC FREEWAY SEGMENTS WORKSHEET			
General Information		Site Information	
Analyst	BAR	Highway/Direction of Travel I-26	
Agency or Company	HNTB North Carolina, PC	From/To	NC 280 to US 25
Date Performed	7/12/2013	Jurisdiction	Buncombe County
Analysis Time Period	Peak	Analysis Year	2040 Build 8 Lanes
Project Description STIP I4400/I-4700 - I-26 Widening			
<input checked="" type="checkbox"/> Oper.(LOS)		<input type="checkbox"/> Des.(N)	
<input type="checkbox"/> Planning Data			
Flow Inputs			
Volume, V	5666	veh/h	Peak-Hour Factor, PHF 0.90
AADT		veh/day	%Trucks and Buses, P _T 6
Peak-Hr Prop. of AADT, K			%RVs, P _R 0
Peak-Hr Direction Prop, D			General Terrain: Rolling
DDHV = AADT x K x D		veh/h	Grade % Length mi
			Up/Down %
Calculate Flow Adjustments			
f _p	1.00	E _R	2.0
E _T	2.5	f _{HV} = 1/[1+P _T (E _T - 1) + P _R (E _R - 1)] 0.917	
Speed Inputs		Calc Speed Adj and FFS	
Lane Width	ft		
Rt-Side Lat. Clearance	ft	f _{LW}	mph
Number of Lanes, N	4	f _{LC}	mph
Total Ramp Density, TRD	ramps/mi	TRD Adjustment	mph
FFS (measured)	65.0	FFS	65.0
Base free-flow Speed, BFFS	mph		mph
LOS and Performance Measures		Design (N)	
<u>Operational (LOS)</u>		<u>Design (N)</u>	
v _p = (V or DDHV) / (PHF x N x f _{HV} x f _p)	1716 pc/h/ln	Design LOS	
S	63.6 mph	v _p = (V or DDHV) / (PHF x N x f _{HV} x f _p)	pc/h/ln
D = v _p / S	27.0 pc/mi/ln	S	mph
LOS	D	D = v _p / S	pc/mi/ln
		Required Number of Lanes, N	
Glossary		Factor Location	
N - Number of lanes	S - Speed	E _R - Exhibits 11-10, 11-12	f _{LW} - Exhibit 11-8
V - Hourly volume	D - Density	E _T - Exhibits 11-10, 11-11, 11-13	f _{LC} - Exhibit 11-9
v _p - Flow rate	FFS - Free-flow speed	f _p - Page 11-18	TRD - Page 11-11
LOS - Level of service	BFFS - Base free-flow speed	LOS, S, FFS, v _p - Exhibits 11-2, 11-3	
DDHV - Directional design hour volume			

BASIC FREEWAY SEGMENTS WORKSHEET			
General Information		Site Information	
Analyst	BAR	Highway/Direction of Travel	I-26
Agency or Company	HNTB North Carolina, PC	From/To	US 25 to US 64
Date Performed	7/12/2013	Jurisdiction	Buncombe County
Analysis Time Period	Peak	Analysis Year	2040 Build 8 Lanes
Project Description <i>STIP I4400/I-4700 - I-26 Widening</i>			
<input checked="" type="checkbox"/> Oper.(LOS)		<input type="checkbox"/> Des.(N)	
<input type="checkbox"/> Planning Data			
Flow Inputs			
Volume, V	5309	veh/h	Peak-Hour Factor, PHF
AADT		veh/day	0.90
Peak-Hr Prop. of AADT, K			%Trucks and Buses, P _T
Peak-Hr Direction Prop, D			6
DDHV = AADT x K x D		veh/h	%RVs, P _R
			0
			General Terrain:
			Rolling
			Grade % Length
			mi
			Up/Down %
Calculate Flow Adjustments			
f _p	1.00	E _R	2.0
E _T	2.5	f _{HV} = 1/[1+P _T (E _T - 1) + P _R (E _R - 1)]	
Speed Inputs		Calc Speed Adj and FFS	
Lane Width	ft		
Rt-Side Lat. Clearance	ft	f _{LW}	mph
Number of Lanes, N	4	f _{LC}	mph
Total Ramp Density, TRD	ramps/mi	TRD Adjustment	mph
FFS (measured)	70.0	FFS	70.0
Base free-flow Speed, BFFS	mph		
LOS and Performance Measures		Design (N)	
<u>Operational (LOS)</u>		<u>Design (N)</u>	
v _p = (V or DDHV) / (PHF x N x f _{HV} x f _p)		Design LOS	
1607	pc/h/ln	v _p = (V or DDHV) / (PHF x N x f _{HV} x f _p)	
S	68.1	pc/h/ln	
D = v _p / S	23.6	S	
LOS	C	mph	
		D = v _p / S	
		pc/mi/ln	
		Required Number of Lanes, N	
Glossary		Factor Location	
N - Number of lanes	S - Speed	E _R - Exhibits 11-10, 11-12	f _{LW} - Exhibit 11-8
V - Hourly volume	D - Density	E _T - Exhibits 11-10, 11-11, 11-13	f _{LC} - Exhibit 11-9
v _p - Flow rate	FFS - Free-flow speed	f _p - Page 11-18	TRD - Page 11-11
LOS - Level of service	BFFS - Base free-flow speed	LOS, S, FFS, v _p - Exhibits 11-2, 11-3	
DDHV - Directional design hour volume			

BASIC FREEWAY SEGMENTS WORKSHEET			
General Information		Site Information	
Analyst	BAR	Highway/Direction of Travel	I-26
Agency or Company	HNTB North Carolina, PC	From/To	US 64 to Upward Road
Date Performed	7/12/2013	Jurisdiction	Buncombe County
Analysis Time Period	Peak	Analysis Year	2040 Build 8 Lanes
Project Description <i>STIP I4400/I-4700 - I-26 Widening</i>			
<input checked="" type="checkbox"/> Oper.(LOS)		<input type="checkbox"/> Des.(N)	
<input type="checkbox"/> Planning Data			
Flow Inputs			
Volume, V	4672	veh/h	Peak-Hour Factor, PHF
AADT		veh/day	0.90
Peak-Hr Prop. of AADT, K			%Trucks and Buses, P _T
Peak-Hr Direction Prop, D			6
DDHV = AADT x K x D		veh/h	%RVs, P _R
			0
			General Terrain:
			Rolling
			Grade % Length
			mi
			Up/Down %
Calculate Flow Adjustments			
f _p	1.00	E _R	2.0
E _T	2.5	f _{HV} = 1/[1+P _T (E _T - 1) + P _R (E _R - 1)]	0.917
Speed Inputs		Calc Speed Adj and FFS	
Lane Width	ft		
Rt-Side Lat. Clearance	ft	f _{LW}	mph
Number of Lanes, N	4	f _{LC}	mph
Total Ramp Density, TRD	ramps/mi	TRD Adjustment	mph
FFS (measured)	70.0	FFS	70.0
Base free-flow Speed, BFFS	mph		mph
LOS and Performance Measures		Design (N)	
<u>Operational (LOS)</u>		<u>Design (N)</u>	
v _p = (V or DDHV) / (PHF x N x f _{HV} x f _p)		Design LOS	
1415	pc/h/ln	v _p = (V or DDHV) / (PHF x N x f _{HV} x f _p)	
S	69.5	pc/h/ln	
D = v _p / S	20.4	S	
LOS	C	mph	
		D = v _p / S	
		pc/mi/ln	
		Required Number of Lanes, N	
Glossary		Factor Location	
N - Number of lanes	S - Speed	E _R - Exhibits 11-10, 11-12	f _{LW} - Exhibit 11-8
V - Hourly volume	D - Density	E _T - Exhibits 11-10, 11-11, 11-13	f _{LC} - Exhibit 11-9
v _p - Flow rate	FFS - Free-flow speed	f _p - Page 11-18	TRD - Page 11-11
LOS - Level of service	BFFS - Base free-flow speed	LOS, S, FFS, v _p - Exhibits 11-2, 11-3	
DDHV - Directional design hour volume			