



STATE OF NORTH CAROLINA  
DEPARTMENT OF TRANSPORTATION

MICHAEL F. EASLEY  
GOVERNOR

LYNDO TIPPETT  
SECRETARY

May 16, 2006

MEMORANDUM TO: Mr. Michael A. Pettyjohn, PE  
Division 11 Engineer

FROM: Philip S. Harris, III, P.E., Unit Head *PHS*  
Natural Environment Unit  
Project Development and Environmental Analysis Branch

SUBJECT: Yadkin County, Widening of NC 67 from SR 1355 to US  
601 in Boonville; T.I.P. Number R-3415; State Project  
6.771008

Attached is the U. S. Army Corps of Engineers 404 Individual Permit and the special conditions for the 401 Water Quality Certification for the above referenced project. All environmental permits have been received for the construction of this project.

PSH/gyb

Attachment

Mr. Majed Alghandour, P. E., Programming and TIP  
Mr. Jay Bennett, P.E., Roadway Design  
Dr. David Chang, P.E., Hydraulics  
Mr. Randy Garris, P.E. State Contract Officer  
Mr. Art McMillan, P.E., Highway Design  
Mr. Greg Perfetti, P.E., Structure Design  
Mr. Mark Staley, Roadside Environmental  
Mr. John F. Sullivan, FHWA  
Ms. Teresa Hart, P.E., PDEA Western Region Unit Head  
Mr. Heath Slaughter, Division Environmental Officer

# PROJECT COMMITMENTS

Widening of NC 67 from SR 1355 to US 601 in Booneville  
Yadkin County  
State Project No. 6.771008  
TIP No.: R-3415

In addition to the standard Individual Section 404 and 401 Permit Conditions, State Consistency Conditions, NCDOT's Guidelines for Best Management Practices for Protection of Surface Waters, the following special commitments have been agreed to by NCDOT:

## **Commitments Developed through Permitting**

### **Division 11**

The temporary diversion structures included in the permit plans at L-stations 119+06 (80 linear feet of stream channel), 141+90 (60 linear feet of stream channel) shall be constructed in accordance with Section 5.2 of the North Carolina Department of Transportation "Best Management Practices for Construction and Maintenance Activities" dated August 2003. All temporary fill shall be removed in its entirety upon completion of the construction at that site.

Sills shall be installed in all multi-barrel box culverts to maintain low-flow velocities and depths for aquatic life passage.

Approximately six (6) months after the installation of a culvert greater than 48 inches in diameter the upstream and downstream areas adjacent to the structure shall be inspected for erosional areas, headcutting, perching, ect. Eighteen (18) months after installation another visional inspection shall be conducted. The appropriate Regional DWQ staff member shall be notified of any problems found during the inspections. NCDOT shall consult with the Regional DWQ staff member to determine if any steps will be necessary to correct the problem and if a permit modification will be needed prior to conducting any work.



**DEPARTMENT OF THE ARMY  
WILMINGTON DISTRICT, CORPS OF ENGINEERS**

P. O. BOX 1890  
WILMINGTON, NORTH CAROLINA 28402-1890

May 10, 2006

IN REPLY REFER TO

Regulatory Division

SUBJECT: Action ID 200520314, TIP No. R-3415

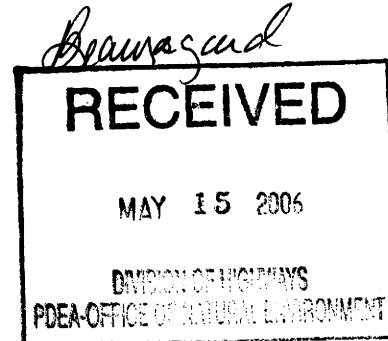

Gregory J. Thorpe, Ph.D.  
Environmental Management Director, PDEA  
N. C. Department of Transportation  
1548 Mail Service Center  
Raleigh, North Carolina 27699-1548

Dear Mr. Thorpe:

Enclosed is a Department of the Army (DA) permit to authorize the discharge of fill material into waters of the United States, for construction of the NC 67 widening and improvements (T.I.P. No. R-3415), impacting Lineberry Creek and its tributaries, Williams Creek and its tributaries, and unnamed tributaries of North Deep Creek, from the intersection of US 601 west to SR 1355 (Messick Road), west of Booneville, in Yadkin County North Carolina. The Corps is issuing this permit in response to your written request of January 11, 2005, and the ensuing administrative record.

Any deviation in the authorized work will likely require modification of this permit. If a change in the authorized work is necessary, you should promptly submit revised plans to the Corps showing the proposed changes. You may not undertake the proposed changes until the Corps notifies you that your permit has been modified.

Carefully read your permit. The general and special conditions are important. Your failure to comply with these conditions could result in a violation of Federal law. Certain significant conditions require that:

- a. You must complete construction before December 31, 2011.
- b. You must notify this office in advance as to when you intend to commence and complete work.
- c. You must allow representatives from this office to make periodic visits to your worksite as deemed necessary to assure compliance with permit plans and conditions.

-2-

You should address all questions regarding this authorization to Mr. John Thomas of my Raleigh Regulatory Field Office at (919) 806-8441, extension 25.

Sincerely,

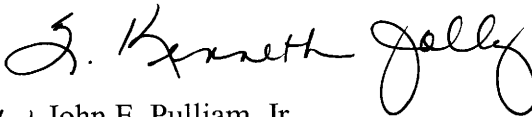
  
John E. Pulliam, Jr.  
Colonel, U.S. Army  
District Engineer

Enclosures

Copy Furnished (with enclosures):

Chief, Source Data Unit  
NOAA/National Ocean Service  
ATTN: Sharon Tear N/CS261  
1315 East-West Hwy., Rm 7316  
Silver Spring, MD 20910-3282

Copies Furnished (with special conditions and plans):

Mr. Ronald Mikulak, Chief  
Wetlands Section - Region IV  
Water Management Division  
U.S. Environmental Protection Agency  
Atlanta Federal Center  
61 Forsyth Street, SW  
Atlanta, Georgia 30303

Mr. Pete Benjamin, Field Supervisor  
U.S. Fish and Wildlife Service  
Fish and Wildlife Enhancement  
Post Office Box 33726  
Raleigh, North Carolina 27636-3726



Mr. Ron Sechler  
National Marine Fisheries  
Service, NOAA  
Pivers Island  
Beaufort, North Carolina 28516

Mr. Doug Huggett  
Division of Coastal Management  
N.C. Department of Environment  
and Natural Resources  
Division of Coastal Management  
400 Commerce Avenue  
Morehead City, North Carolina 28557-3421

Mr. Dave Rackley  
National Marine Fisheries  
Service, NOAA  
Pivers Island  
Beaufort, North Carolina 28516

DEPARTMENT OF THE ARMY PERMIT

Permittee: NORTH CAROLINA DEPARTMENT OF TRANSPORTATION  
GREGORY J. THORPE, Ph.,D.

Permit No: 200520314

Issuing Office: USAED, WILMINGTON

**RECEIVED**  
APR 27 2006  
**REGULATORY**  
WILM. FLD. OFC.

**RECEIVED**  
APR 19 2006  
DIVISION OF HIGHWAYS  
PDEA-OFFICE OF NATURAL ENVIRONMENT

RECEIVED  
APR 19 2006  
PROJECT ENGINEER  
DIVISION OF HIGHWAYS  
PDEA-OFFICE OF NATURAL ENVIRONMENT

**NOTE:** The term "you" and its derivatives, as used in this permit, means the permittee or any future transferee. The term "this office" refers to the appropriate district or division office of the Corps of Engineers having jurisdiction over the permitted activity or the appropriate official of the office acting under the authority of the commanding officer.

You are authorized to perform work in the accordance with the terms and conditions specified below.

**Project Description:** Place fill material impacting approximately 1212 linear feet of stream channel in the jurisdictional waters of the Yadkin Pee-Dee River basin for construction of the NC 67 widening and improvements (T.I.P. No. R-3415).

**Project Location:** From the intersection of US 601 west to SR 1355 (Messick Road), west of Booneville, in Yadkin County, North Carolina.

**Permit Conditions:**

**General Conditions:**

1. The time Limit for completing the work authorized ends on December 31, 2011. If you find that you need more time to complete the authorized activity, submit your request for a time extension to this office for consideration at least one month before the above date is reached.
2. You must maintain the activity authorized by this permit in good condition and in conformance with the terms and conditions of this permit. You are not relieved of this requirement if you abandon the permitted activity, although you may make a good faith transfer to a third party in compliance with General Conditions 4 below. Should you wish to cease to maintain the authorized activity or should you desire to abandon it without a good faith transfer, you must obtain a modification of this permit from this office, which may require restoration of the area.
3. If you discover any previously unknown historic or archeological remains while accomplishing the activity authorized by this permit, you must immediately notify this office of what you have found. We will initiate the Federal and state coordination required to determine if the remains warrant a recovery effort or if the site eligible for listing in the National Register of Historic Places.

4. If you sell the property associate with this permit, you must obtain the signature of the new owner in the space provided and forward a copy of the permit to this office to validate the transfer of this authorization.

5. If a conditioned water quality certification has been issued for your project, you must comply with the conditions specified in the certification as special conditions to this permit. For your convenience, a copy of the certification is attached if it contains such conditions.

6. You must allow representatives from this office to inspect the authorized activity at any time deemed necessary to ensure that it is being or has been accomplished in accordance with the terms and conditions of your permit.

**Special Conditions:**

\*SEE ATTACHED SPECIAL CONDITIONS

**Further Information:**

1. Congressional Authorities: You have been authorized to undertake the activity described above pursuant to:

( ) Section 10 of the Rivers and Harbors Act of 1899 (33 U.S. C. 403).

(X) Section 404 of the clean Water Act (33 U.S.C. 1344).

( ) Section 103 of the Marine Protection, Research and Sanctuaries Act of 1972 (33 U.S.C. 1413).

2. Limits of this authorization.

a. This permit does not obviate the need to obtain other Federal, state, or local authorizations required by law.

b. This permit does not grant any property rights or exclusive privileges.

c. This permit does not authorize any injury to the property or rights of others.

d. This permit does not authorize interference with any existing or proposed Federal project.

3. Limits of Federal Liability. In issuing this permit, the Federal Government does not assume any liability for the following:

a. Damages to the permitted project or uses thereof as a result of other permitted or unpermitted activities or from natural causes.

b. Damages to the permitted project or uses thereof as a result of current or future activities undertaken by or on behalf of the United states in the public interest.

c. Damages to persons, property, or to other permitted or unpermitted activities or structures caused by the activity authorized by this permit.

d. Design or construction deficiencies associated with the permitted work.

e. Damage claims associated with any future modification, suspension, or revocation of this permit.

4. Reliance on Applicant's Data: The determination of this office that issuance of this permit is not contrary to the public interest was made in reliance on the information you provided.

5. Reevaluation of Permit Decision. This office may reevaluate its decision on this permit at any time the circumstances warrant. Circumstances that could require a reevaluation include, but are not limited to, the following:

- a. You fail to comply with the terms and conditions of this permit.
- b. The information provided by you in support of your permit application proves to have been false, incomplete, or inaccurate (see 4 above).
- c. Significant new information surfaces which this office did not consider in reaching the original public interest decision.

Such a reevaluation may result in a determination that it is appropriate to use the suspension, modification, and revocation procedures contained in 33 CFR 325.7 or enforcement procedures such as those contained in 33CFR 326.4 and 326.5. The referenced enforcement procedures provide for the issuance of an administrative order requiring you to comply with the terms and conditions of your permit and for the initiation of legal action where appropriate. You will be required to pay for any corrective measures ordered by this office, and if you fail to comply with such directive, this office may in certain situations (such as those specified in 33 CFR 209.170) accomplish the corrective measure by contract or otherwise and bill you for the cost.

6. Extensions. General condition 1 establishes a time limit for the completion of the activity authorized by this permit. Unless there are circumstances requiring either a prompt completion of the authorized activity or a reevaluation of the public interest decision, the Corps will normally give favorable consideration to a request for an extension of this time limit.

Your signature below, as permittee, indicates that you accept and agree to comply with the terms and conditions of this permit.

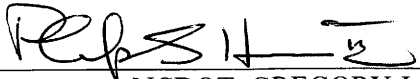
  
\_\_\_\_\_  
(PERMITTEE) NCDOT, GREGORY J. THORPE, Ph.,D. 4/25/06  
\_\_\_\_\_  
(DATE)

This permit becomes effective when the Federal official, designated to act for the Secretary of the Army, has signed below.

  
\_\_\_\_\_  
(DISTRICT ENGINEER) JOHN E. PULLIAM, JR., COLONEL 5/10/06  
\_\_\_\_\_  
(DATE)

When the structures or work authorized by this permit are still in existence at the time the property is transferred, the terms and conditions of this permit will continue to be binding on the new owner(s) of the property. To validate the transfer of this permit and the associated liabilities associated with compliance with its terms and conditions, have the transferee sign and date below.

\_\_\_\_\_  
(TRANSFEE) \_\_\_\_\_  
(DATE)

SPECIAL CONDITIONS (Action ID. 200520314; NCDOT/TIP R-3415)

COMPLIANCE WITH PLANS

a. All work must be performed in strict compliance with the attached plans including plans for temporary fill impacts in jurisdictional waters, which are a part of this permit. Any modification to the permit plans must be approved by the USACE prior to implementation.

COMPLIANCE WITH SPECIAL CONDITIONS

b. Failure to institute and carry out the details of the following special conditions, below, would result in a directive to cease all ongoing and permitted work within waters and/or wetlands associated with the permitted project, or such other remedies and/or fines as the District Engineer or his authorized representatives may seek.

CONSTRUCTION PLANS

c. The permittee would ensure that the construction design plans for this project do not deviate from the permit plans attached to this authorization. Written verification shall be provided that the final construction drawings comply with the attached permit drawings prior to any active construction in waters of the United States, including wetlands. Any deviation in the construction design plans would be brought to the attention of the Corps of Engineers, Raleigh Regulatory Field Office prior to any active construction in jurisdictional waters including jurisdictional wetlands.

PRECONSTRUCTION MEETING

d. The permittee shall schedule a preconstruction meeting between its representatives, the contractor's representatives, and the Corps of Engineers, Raleigh Regulatory Field Office, NCDOT Regulatory Project Manager, prior to any work within jurisdictional waters including jurisdictional wetlands to ensure that there is a mutual understanding of all of the terms and conditions contained within this Department of the Army Permit. The permittee shall provide the USACE, Raleigh Regulatory Field Office, NCDOT Regulatory Project Manager, with a copy of the final plans at least two weeks prior to the preconstruction meeting along with a description of any changes that have been made to the project's design, construction methodology or construction timeframe. The permittee shall schedule the preconstruction meeting for a time when the USACE and North Carolina Division of Water Quality (NCDWQ) Project Managers can attend. The permittee shall invite the Corps and NCDWQ Project Managers a minimum of thirty (30) days in advance of the scheduled meeting in order to provide those individuals with ample opportunity to schedule and participate in the required meeting.

CONTRACTOR COMPLIANCE

e. The permittee shall require its contractors and/or agents to comply with the terms and conditions of this permit in the construction and maintenance of this project, and shall provide each of its contractors and/or agents associated with the construction or maintenance of this project with a copy of this permit, and any authorized modifications. A copy of this permit, and any authorized modifications, including all conditions, shall be available at the project site during construction and maintenance of this project.

## CONSTRUCTION DRAWINGS

f. Prior to commencing construction within jurisdictional waters of the United States for any portion of the proposed highway project, the permittee shall forward the latest version of project construction drawings to the Corps of Engineers, Raleigh Regulatory Field Office NCDOT Regulatory Project Manager. Half-size drawings will be acceptable.

## ACTIVITIES NOT AUTHORIZED

g. Except as authorized by this permit or any USACE approved modification to this permit, no excavation, fill, or mechanized land-clearing activities shall take place at any time in the construction or maintenance of this project, within jurisdictional waters including jurisdictional wetlands, or shall any activities take place that cause the degradation of jurisdictional waters including jurisdictional wetlands. In addition, except as specified in the plans attached to this permit, no excavation, fill or mechanized land-clearing activities shall take place at any time in the construction or maintenance of this project, in such a manner as to impair normal flows and circulation patterns within, into, or out of jurisdictional waters including jurisdictional wetlands or to reduce the reach of jurisdictional waters including jurisdictional wetlands.

This permit does not authorize temporary placement or double handling of excavated or fill material within jurisdictional waters including jurisdictional wetlands outside the permitted area defined by the attached plans that are a part of this permit. In addition, no construction material or equipment will be placed or stored within jurisdictional waters including jurisdictional wetlands outside the permitted area.

## BORROW AND WASTE

h. To ensure that all borrow and waste activities occur on high ground and do not result in the degradation of adjacent wetlands and streams, except as authorized by this permit, the permittee shall require its contractors and/or agents to identify all areas to be used to borrow material, or to dispose of dredged, fill, or waste material. The permittee shall provide the USACE with appropriate maps indicating the locations of proposed borrow or waste sites as soon as the permittee has that information. The permittee will coordinate with the USACE before approving any borrow or waste sites that are within 400 feet of any streams or wetlands. All jurisdictional wetland lines on borrow and waste sites shall be verified by the Corps of Engineers and shown on the approved reclamation plans. The permittee shall ensure that all such areas comply with the **preceding condition** of this permit, and shall require and maintain documentation of the location and characteristics of all borrow and disposal sites associated with this project. This information will include data regarding soils, vegetation and hydrology sufficient to clearly demonstrate compliance with the **preceding condition**. All information will be available to the USACE upon request. NCDOT shall require its contractors to complete and execute reclamation plans for each waste and borrow site and provide written documentation that the reclamation plans have been implemented and all work is completed. This documentation will be provided to the Corps of Engineers within 30 days of the completion of the reclamation work.

## REPORTING OF VIOLATIONS

i. The permittee will report any violation of these conditions or violations of Section 404 of the Clean Water Act or Section 10 of the Rivers and Harbors Act in writing to the Wilmington District, U. S Army Corps of Engineers, within 24 hours of the permittee's discovery of the violation.

## SEDIMENTATION AND EROSION CONTROL MEASURES

j. The permittee shall use appropriate sediment and erosion control practices which equal or exceed those outlined in the most recent version of the "North Carolina Sediment and Erosion Control Planning and Design Manual" to assure compliance with the appropriate turbidity water quality standard. Erosion and sediment control practices must be in full compliance with all specifications governing the proper design, installation and operation and maintenance of such Best Management Practices in order to assure compliance with the appropriate turbidity water quality standards. Additionally, the project must remain in full compliance with all aspects of the Sedimentation Pollution Control Act of 1973 (North Carolina General Statutes Chapter 113A Article 4).

Adequate sedimentation and erosion control measures must be implemented prior to any ground disturbing activities to minimize impacts to downstream aquatic resources. These measures must be inspected and maintained regularly, especially following rainfall events. All fill material must be adequately stabilized at the earliest practicable date to prevent sediment from entering into adjacent jurisdictional waters including jurisdictional wetlands.

The permittee shall remove all sediment and erosion control measures placed in jurisdictional waters including jurisdictional wetlands, and shall restore natural grades in those areas, prior to project completion.

During the clearing phase of the project, heavy equipment must not be operated in surface waters or stream channels. Temporary stream crossings will be used to access the opposite sides of stream channels. All temporary diversion channels and stream crossings will be constructed of nonerodable materials. Grubbing of riparian vegetation will not occur until immediately before construction begins on a given segment of stream channel.

## CULVERTS

k. All authorized culverts will be installed to allow the passage of low stream flows and the continued movement of fish and other aquatic life as well as to prevent headcutting of the streambed. For all box culverts and for pipes greater than 48 inches in diameter, the bottom of the pipe will be buried at least one foot below the bed of the stream unless burial would be impractical and the Corps of Engineers has waived this requirement. For culverts 48 inches in diameter or smaller, the bottom of the pipe must be buried below the bed of the stream to a depth equal to or greater than 20 percent of the diameter of the culvert. . Design and placement of culverts and other structures including temporary erosion control measures shall not be conducted in a manner that may result in disequilibrium of wetlands or streambeds or banks, adjacent to, upstream or downstream of the structures. In order to allow for the continued movement of bed load and aquatic organisms, existing stream channel widths and depths will be maintained at the inlet and outlet ends of culverts. Riprap armoring of streams at culvert inlets will be constructed in accordance with the North Carolina Department of Transportation "Best Management Practices for Construction and Maintenance Activities" dated August 2003.

## WET CONCRETE

l. The permittee shall take measures to prevent live or fresh concrete from coming into contact with any surface waters until the concrete has hardened.

## POLLUTION SPILLS

m. All mechanized equipment will be regularly inspected and maintained to prevent contamination of jurisdictional waters including jurisdictional wetlands from fuels, lubricants, hydraulic fluids, or other toxic materials. No equipment staging or storage of construction material will occur in wetlands. Hydro-seeding equipment will not be discharged or washed out into any surface waters or wetlands. In the event of a spill of petroleum products or any other hazardous waste, the permittee shall immediately report it to the N.C. Division of Water Quality at (919) 733-5083 or (800) 662-7956 and provisions of the North Carolina Oil Pollution and Hazardous Substances Control Act will be followed.

## CLEAN FILL MATERIAL

n. Unless otherwise authorized by this permit, all fill material placed in jurisdictional waters including jurisdictional wetlands shall be generated from an upland source and will be clean and free of any pollutants except in trace quantities. Metal products, organic materials (including debris from land clearing activities), or unsightly debris will not be used.

## OTHER AUTHORIZATIONS

o. This Department of the Army permit does not obviate the need to obtain other Federal, state, or local authorizations required by law.

## PROPERTY RIGHTS

p. This permit does not grant any property rights or exclusive privileges.

## GOVERNMENT LIABILITY

q. In issuing this permit, the Federal Government does not assume any liability for:

Damages to the permitted project or uses thereof as a result of other permitted or unpermitted activities or from natural causes.

Damages to the permitted project or uses thereof as a result of current or future Federal activities initiated on behalf of the general public.

Damages to other permitted or un-permitted activities or structures caused by the authorized activity.

Design and construction deficiencies associated with the permitted work.

Damage claims associated with any future modification, suspension, or revocation of this permit.

## TEMPORARY FILLS

r. The temporary diversion structures included in the permit plans at L-stations 119+06 (80 linear feet of stream channel), 141+90 (60 linear feet of stream channel), and 171+37 (55 linear feet of stream channel) shall be constructed in accordance with Section 5.2 of the North Carolina Department of Transportation "Best Management Practices for Construction and Maintenance



Activities” dated August 2003. All temporary fill shall be removed in its entirety upon completion of the construction at that site.

## **MITIGATION**

s. Compensatory mitigation for the unavoidable permanent impacts to 1212 linear feet of stream channel within the Yadkin Pee-Dee River Basin (HU 03040101) shall be provided by the North Carolina Ecosystem Enhancement Program (EEP), as outlined in the letter dated March 16, 2005, from William D. Gilmore, EEP Transition Manager. Pursuant to the EEP Memorandum of Agreement (MOA) between the State of North Carolina and the US Army Corps of Engineers signed on July 22, 2003, the EEP will provide 937 linear feet of restoration equivalent cool water stream channel and 275 linear feet of restoration equivalent warm water stream channel in the Yadkin Pee-Dee River Basin (HU 03040101) by one year of the date of this permit.

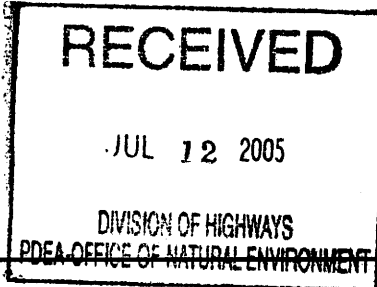

*Beauregard*

Michael F. Easley, Governor

William G. Ross Jr., Secretary  
North Carolina Department of Environment and Natural Resources

Alan W. Klimek, P.E. Director  
Division of Water Quality

July 1, 2005

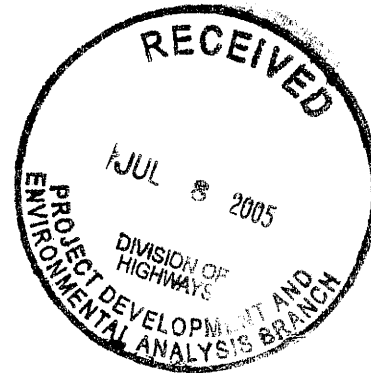

Dr. Gregory J. Thorpe, PhD., Manager  
Planning and Environmental Branch  
North Carolina Department of Transportation  
1548 Mail Service Center  
Raleigh, North Carolina, 27699-1548

Dear Dr. Thorpe:

Re: Modification to 401 Water Quality Certification Pursuant to Section 401 of the Federal Clean Water Act for the Proposed Widening to NC 67 from SR 1355 to US 601, TIP No. R-3415 Individual WQC No. 3502 Yadkin County

Attached hereto is a copy of modified Certification No. 3502 issued to The North Carolina Department of Transportation dated June 3, 2005. The certification has been issued to modify condition #3. This Certification hereby replaces the Certification No. 3502 issued March 28, 2005 and the Modification issued June 3, 2005.

If we can be of further assistance, do not hesitate to contact Sue Homewood at 336-771-4600 extension 287 or at Sue.Homewood@ncmail.net.

Sincerely,

Alan W. Klimek, P.E.  
Director

cc: John Thomas, Army Corps of Engineers Raleigh Regulatory Field Office  
Heath Slaughter, Division Environmental Officer, NCDOT Division 11  
Marla Chambers, NC Wildlife Resources Commission  
Marella Buncick, US Fish and Wildlife Services  
Central Files  
401 Wetlands Transportation Unit  
DWQ Winston-Salem Regional Office

One North Carolina  
*Naturally*

**APPROVAL OF 401 Water Quality Certification and Additional Conditions**

**THIS CERTIFICATION** is issued in conformity with the requirements of Section 401 Public Laws 92-500 and 95-217 of the United States and subject to the North Carolina Division of Water Quality (DWQ) Regulations in 15 NCAC 2H, Section .0500, and 15 NCAC 2B .0259. This certification authorizes the NCDOT to place permanent to place temporary fill material in 260 feet of streams in Yadkin County and permanent fill material, culverts, and piping in 1,212 linear feet of streams in Yadkin County. The project shall be constructed pursuant to the application and supplemental information dated January 7, 2004 (received January 11, 2005) and March 21, 2005 (received March 21, 2005), respectively, and the modification application dated May 18, 2004 (received May 24, 2005) to improve the section of NC 67 from SR 1355 (Messick Road) to US 601 in Yadkin County. The approved design is that submitted in your application, supplemental information, and modification dated January 7, 2004 and March 21, 2005, and May 18, 2005 respectively. The authorized impacts are as described below:

**Table 1. Surface Water Impacts for the Yadkin-Pee Dee River Basin**

<b>Section</b>	<b>Stream</b>	<b>Temporary Stream Impacts (linear feet)</b>	<b>Stream Impacts (linear feet)</b>	<b>Stream Type</b>	<b>Mitigation Required (linear feet)</b>
Site 1	Lineberry Creek	65	32	Perennial	0
Site 1	UT to Lineberry Creek		325	Perennial	325
Site 2	Williams Creek	80	28	Perennial	28
Site 3	Williams Creek	60	254	Perennial	254
Site 3	UT to Williams Creek		74	Perennial	0
Site 4	UT to Williams Creek		60	Perennial	0
Site 5	UT to Williams Creek	55	38	Perennial	0
Site 6	UT to North Deep Creek		126	Perennial	0
Site 7	UT to North Deep Creek		48	Perennial	0
Site 8	UT to North Deep Creek		49	Perennial	0
Site 9	UT to North Deep Creek		98	Perennial	0
Site 10	UT to North Deep Creek		80	Perennial	0
<b>Total</b>		<b>260</b>	<b>1,212</b>		<b>607</b>

The application provides adequate assurance that the discharge of fill material into the waters of the Yadkin-Pee Dee River Basin in conjunction with the proposed development will not result in a violation of applicable Water Quality Standards and discharge guidelines. Therefore, the State of North Carolina certifies that this activity will not violate the applicable portions of Sections 301, 302, 303, 306, 307 of PL 92-500 and PL 95-217 if conducted in accordance with the application and conditions hereinafter set forth.

This approval is only valid for the purpose and design that you submitted in your application, as described in the Public Notice. Should your project change, you are required to notify the DWQ and submit a new application. If the property is sold, the new owner must be given a copy of this Certification and approval letter, and is thereby responsible for complying with all the conditions. If any additional wetland impacts, or stream impacts, for this project (now or in the future) exceed one acre or 150 linear feet, respectively, additional compensatory mitigation may be required as described in 15A NCAC 2H .0506 (h) (6) and (7). For this approval to remain valid, you are required to comply with all the conditions listed below. In addition, you should obtain all other federal, state or local permits before proceeding with your project including (but not limited to) Sediment and Erosion control, Coastal Stormwater, Non-discharge and Water Supply watershed regulations. This Certification shall expire three years from the date of the cover letter from DWQ or on the same day as the expiration date of the corresponding Corps of Engineers Permit, whichever is sooner.

Condition(s) of Certification:

Project Specific Conditions of Certification:

1. We understand that you have chosen to perform compensatory mitigation for 607 linear feet of impacts to streams through an in-lieu payment to the North Carolina Ecosystem Enhancement Program (NCEEP). NCEEP has indicated in a letter dated March 16, 2005 that they will assume responsibility for satisfying the federal Clean Water Act compensatory mitigation requirements for the above-referenced project as detailed in the table below.

Type of Impact	Amount of Impact
Streams	607 lf

2. Sills shall be installed in all multi-barrel box culverts to maintain low-flow velocities and depths for aquatic life passage.
3. Approximately six (6) months after the installation of a culvert greater than 48 inches in diameter the upstream and downstream areas adjacent to the structure shall be inspected for erosional areas, headcutting, perching, etc. Eighteen (18) months after installation another visual inspection shall be conducted. The appropriate Regional DWQ staff member shall be notified of any problems found during the inspections. NCDOT shall consult with the Regional DWQ staff member to determine if any steps will be necessary to correct the problem and if a permit modification will be needed prior to conducting any work.

General Conditions of Certification:

4. The dimension, pattern and profile of the stream above and below the crossing should not be modified by widening the stream channel or reducing the depth of the stream. Disturbed floodplains and streams should be restored to natural geomorphic conditions. All stream relocation and restoration activities shall comply with the final natural channel design plans approved by the NC Division of Water Quality.

5. Construction will be conducted in such a manner as to prevent a significant increase in turbidity outside the area of construction or construction-related discharge. Erosion and sediment control practices must be in full compliance with all specifications governing the proper design, installation and operation and maintenance of such Best Management Practices in order to assure compliance with the appropriate turbidity water quality standard.
  - a. The erosion and sediment control measures for the project must equal or exceed the proper design, installation, operation and maintenance outlined in the most recent version of the North Carolina Sediment and Erosion Control Planning and Design Manual. These devices shall be maintained on all construction sites, borrow sites, and waste pile (spoil) projects, including contractor-owned or leased borrow pits associated with the project.
  - b. For borrow pit sites, the erosion and sediment control measures must equal or exceed the proper design, installation, operation and maintenance outlined in the most recent version of the North Carolina Surface Mining Manual. The reclamation measures and implementation must comply with the reclamation in accordance with the requirements of the Sedimentation Pollution Control Act.
6. All sediment and erosion control measures shall not be placed in wetlands or waters to the maximum extent practicable. If placement of sediment and erosion control devices in wetlands and waters is unavoidable, they shall be removed and the natural grade restored after the Division of Land Resources has released the project.
7. If an environmental document is required, this Certification is not valid until a FONSI or ROD is issued by the State Clearinghouse. All water quality-related conditions of the FONSI or ROD shall become conditions of this Certification.
8. No live or fresh concrete shall come into contact with waters of the state until the concrete has hardened.
9. There shall be no excavation from or waste disposal into jurisdictional wetlands or waters associated with this permit without appropriate modification of this permit. Should waste or borrow sites be located in wetlands or stream, compensatory mitigation will be required since it is a direct impact from road construction activities.
10. Excavation of the stream crossings should be conducted in the dry. Sandbags, cofferdams, flexible pipe, or other diversion structures should be used to minimize excavation in flowing water.
11. All channel relocations will be constructed in a dry work area, and stabilized before stream flows are diverted. Channel relocations will be completed and stabilized prior to diverting water into the new channel. Whenever possible, channel relocations shall be allowed to stabilize for an entire growing season. Vegetation used for bank stabilization shall be limited to native woody species, and should include establishment of a 30 foot wide wooded and an adjacent 20 foot wide vegetated buffer on both sides of the relocated channel to the maximum extent practical. A transitional phase incorporating coir fiber and seedling establishment is allowable. Also, rip-rap may be allowed if it is necessary to maintain the physical integrity of the stream, but the applicant must provide written justification and any calculations used to determine the extent of rip-rap coverage requested.
12. Upon completion of the project, the NCDOT shall complete and return the enclosed "Certification of Completion Form" to notify DWQ when all work included in the 401 Certification has been completed. The responsible party shall complete the attached form and return it to the 401/Wetlands Unit of the Division of Water Quality upon completion of the project.

13. Placement of culverts and other structures in waters, streams, and wetlands must be placed below the elevation of the streambed to allow low flow passage of water and aquatic life unless it can be shown to DWQ that providing passage would be impractical. Design and placement of culverts and other structures including temporary erosion control measures shall not be conducted in a manner that may result in dis-equilibrium of wetlands or streambeds or banks, adjacent to or upstream and down stream of the above structures. The applicant is required to provide evidence that the equilibrium shall be maintained if requested in writing by DWQ.
14. During the construction of the project, no staging of equipment of any kind is permitted in waters of the U.S., or protected riparian buffers.
15. All temporary fills in wetlands and surface waters shall be removed upon completion of the project. In addition, the post-construction removal of any temporary bridge structures or fill will need to return the project site to its preconstruction contours and elevations. The revegetation of the impacted areas with appropriate native species will be required.
16. Riparian vegetation must be reestablished within the construction limits of the project by the end of the growing season following completion of construction.
17. Heavy equipment should be operated from the bank rather than in the stream channel whenever possible in order to minimize sedimentation and reduce the likelihood of introducing other pollutants into the stream. All mechanized equipment operated near surface waters must be regularly inspected and maintained to prevent contamination of stream waters from fuels, lubricants, hydraulic fluids, or other toxic materials.
18. Discharging hydroseed mixtures and washing out hydroseeders and other equipment in or adjacent to surface waters is prohibited.
19. Two copies of the final construction drawings shall be furnished to NCDWQ prior to the pre-construction meeting. Written verification shall be provided that the final construction drawings comply with the attached permit drawings contained in the application dated January 7, 2004.
20. The outside buffer, wetland or water boundary located within the construction corridor approved by this authorization shall be clearly marked by highly visible fencing prior to any land disturbing activities. Impacts to areas within the fencing are prohibited unless otherwise authorized by this certification.
21. NCDOT, and its authorized agents, shall conduct its activities in a manner consistent with State water quality standards (including any requirements resulting from compliance with §303(d) of the Clean Water Act) and any other appropriate requirements of State law and Federal law. If DWQ determines that such standards or laws are not being met (including the failure to sustain a designated or achieved use) or that State or federal law is being violated, or that further conditions are necessary to assure compliance, DWQ may reevaluate and modify this certification to include conditions appropriate to assure compliance with such standards and requirements in accordance with 15A NCAC 2H.0507(d). Before modifying the certification, DWQ shall notify NCDOT and the US Army Corps of Engineers, provide public notice in accordance with 15A NCAC 2H.0503 and provide opportunity for public hearing in accordance with 15A NCAC 2H.0504. Any new or revised conditions shall be provided to NCDOT in writing, shall be provided to the United States Army Corps of Engineers for reference in any permit issued pursuant to Section 404 of the Clean Water Act, and shall also become conditions of the 404 Permit for the project.

22. A copy of this Water Quality Certification shall be posted on the construction site at all times. In addition, the Water Quality Certification (and all subsequent modifications, if any, shall be maintained with the Division Engineer and the on-site project manager.
23. Culverts that are less than 48-inch in diameter should be buried to a depth equal to or greater than 20% of their size to allow for aquatic life passage. Culverts that are 48-inch in diameter or larger should be buried at least 12 inches below the stream bottom to allow natural stream bottom material to become established in the culvert following installation and to provide aquatic life passage during periods of low flow. These measurements must be based on natural thalweg depths.

Violations of any condition herein set forth may result in revocation of this Certification and may result in criminal and/or civil penalties. This Certification shall become null and void unless the above conditions are made conditions of the Federal 404 and/or Coastal Area Management Act Permit. This Certification shall expire upon the expiration of the 404 permit.

If this Certification is unacceptable to you have the right to an adjudicatory hearing upon written request within sixty (60) days following receipt of this Certification. This request must be in the form of a written petition conforming to Chapter 150B of the North Carolina General Statutes and filed with the Office of Administrative Hearings, P.O. Box 27447, Raleigh, N.C. 27611-7447. If modifications are made to an original Certification, you have the right to an adjudicatory hearing on the modifications upon written request within sixty (60) days following receipt of the Certification. Unless such demands are made, this Certification shall be final and binding.

This the 1<sup>st</sup> day of July 2005

DIVISION OF WATER QUALITY

Alan W. Klimek, P.E.

Director

**DWQ Project No.:** 3502                      **County:** Yadkin

**Applicant:** NC Department of Transportation

**Project Name:** \_\_\_\_\_

**Date of Issuance of 401 Water Quality Certification:** \_\_\_\_\_

**Certificate of Completion**

Upon completion of all work approved within the 401 Water Quality Certification or applicable Buffer Rules, and any subsequent modifications, the applicant is required to return this certificate to the 401/Wetlands Unit, North Carolina Division of Water Quality, 1650 Mail Service Center, Raleigh, NC, 27699-1650. This form may be returned to DWQ by the applicant, the applicant's authorized agent, or the project engineer. It is not necessary to send certificates from all of these.

**Applicant's Certification**

I, \_\_\_\_\_, hereby state that, to the best of my abilities, due care and diligence was used in the observation of the construction such that the construction was observed to be built within substantial compliance and intent of the 401 Water Quality Certification and Buffer Rules, the approved plans and specifications, and other supporting materials.

Signature: \_\_\_\_\_ Date: \_\_\_\_\_

**Agent's Certification**

I, \_\_\_\_\_, hereby state that, to the best of my abilities, due care and diligence was used in the observation of the construction such that the construction was observed to be built within substantial compliance and intent of the 401 Water Quality Certification and Buffer Rules, the approved plans and specifications, and other supporting materials.

Signature: \_\_\_\_\_ Date: \_\_\_\_\_

**Engineer's Certification**

\_\_\_\_\_ Partial                      \_\_\_\_\_ Final

I, \_\_\_\_\_, as a duly registered Professional Engineer in the State of North Carolina, having been authorized to observe (periodically, weekly, full time) the construction of the project, for the Permittee hereby state that, to the best of my abilities, due care and diligence was used in the observation of the construction such that the construction was observed to be built within substantial compliance and intent of the 401 Water Quality Certification and Buffer Rules, the approved plans and specifications, and other supporting materials.

Signature \_\_\_\_\_

Registration No. \_\_\_\_\_

Date \_\_\_\_\_



# YADKIN COUNTY NORTH CAROLINA

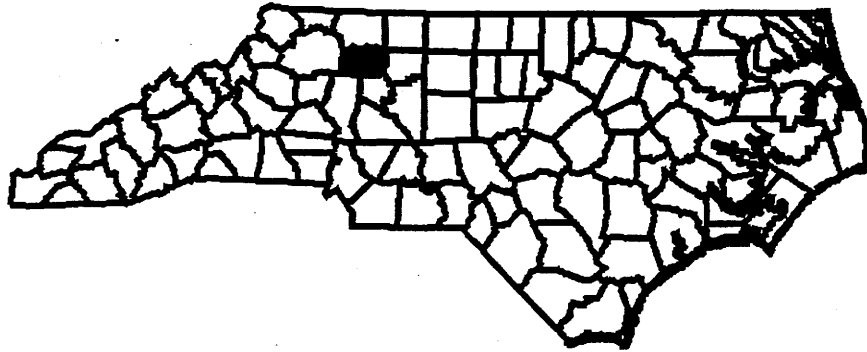

END PROJECT

BEGIN PROJECT

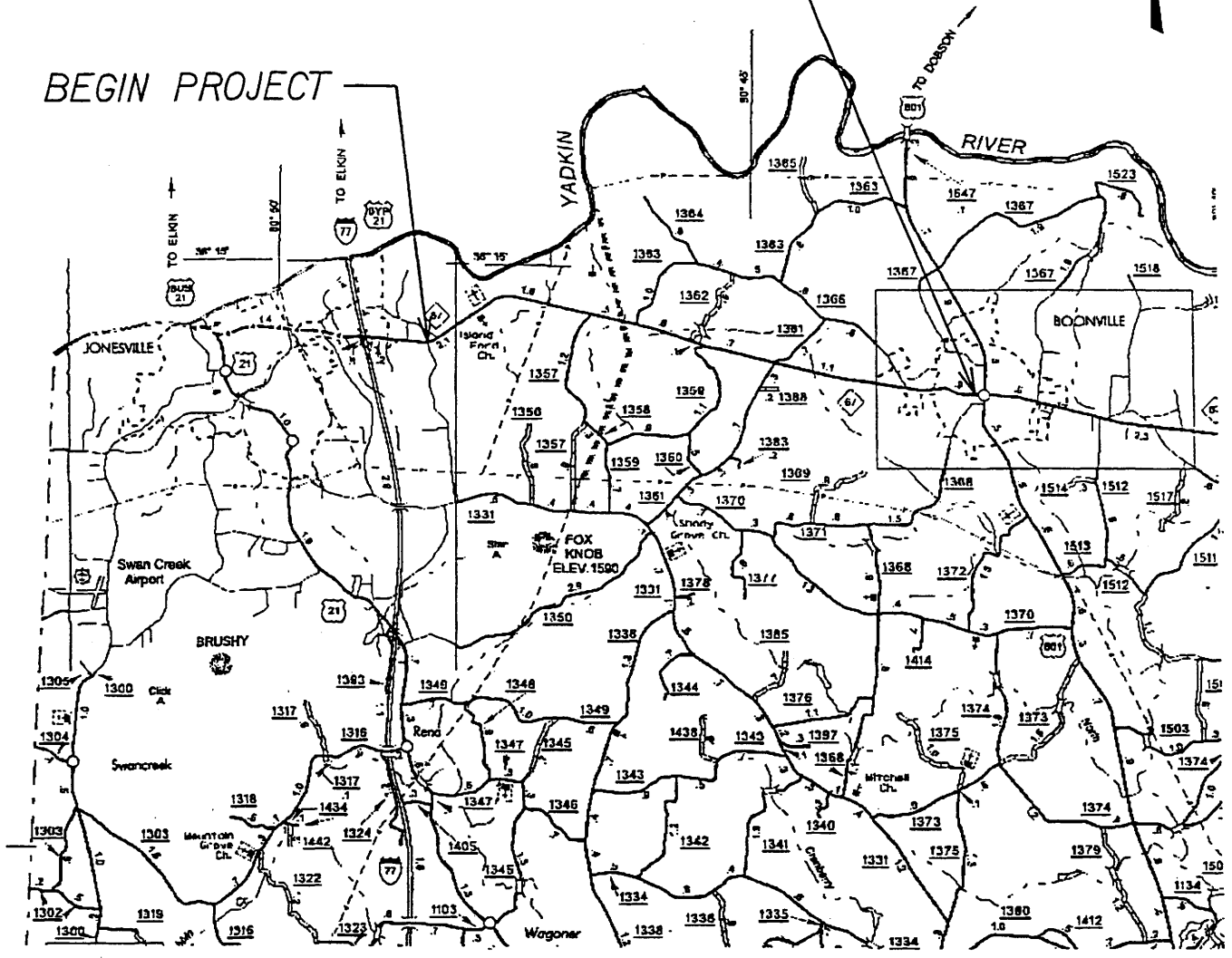

VICINITY  
MAP

DIVISION OF HIGHWAYS  
N.C. DEPT. OF TRANSPORTATION  
YADKIN COUNTY

PROJECT: R-3415  
IMPROVEMENT OF NC 67 FROM SR 1355  
(MESSICK) ROAD TO JUST WEST OF  
BOONVILLE

# LEGEND

— WLB — WETLAND BOUNDARY

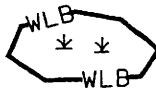
 WETLAND

 DENOTES FILL IN WETLAND

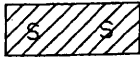
 DENOTES FILL IN SURFACE WATER

 DENOTES FILL IN SURFACE WATER (POND)

 DENOTES TEMPORARY FILL IN WETLAND

 DENOTES EXCAVATION IN WETLAND

 DENOTES TEMPORARY FILL IN SURFACE WATER

 DENOTES MECHANIZED CLEARING

— — FLOW DIRECTION

— TB — TOP OF BANK

.. WE .. EDGE OF WATER

— C — PROP. LIMIT OF CUT

— F — PROP. LIMIT OF FILL

—▲— PROP. RIGHT OF WAY

— NG — NATURAL GROUND

— PL — PROPERTY LINE

— TDE — TEMP. DRAINAGE EASEMENT

— PDE — PERMANENT DRAINAGE EASEMENT

— EAB — EXIST. ENDANGERED ANIMAL BOUNDARY

— EPB — EXIST. ENDANGERED PLANT BOUNDARY

— ∇ — WATER SURFACE

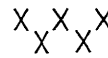
 LIVE STAKES

 BOULDER

— — — COIR FIBER ROLLS

 ADJACENT PROPERTY OWNER OR PARCEL NUMBER

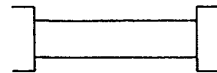
 PROPOSED BRIDGE

 PROPOSED BOX CULVERT

 PROPOSED PIPE CULVERT

(DASHED LINES DENOTE EXISTING STRUCTURES)

 SINGLE TREE

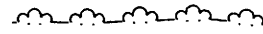
 WOODS LINE

 DRAINAGE INLET

 ROOTWAD

 VANE

 RIP RAP

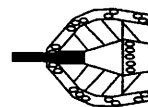
 RIP RAP ENERGY DISSIPATOR BASIN

— — — — — BUFFER ZONE

# LEGEND

**DIVISION OF HIGHWAYS  
N.C. DEPT. OF TRANSPORTATION  
YADKIN COUNTY**

**PROJECT: R-3415  
IMPROVEMENT OF NC 67 FROM SR 1355  
(MESSICK) ROAD TO JUST WEST OF  
BOONVILLE**

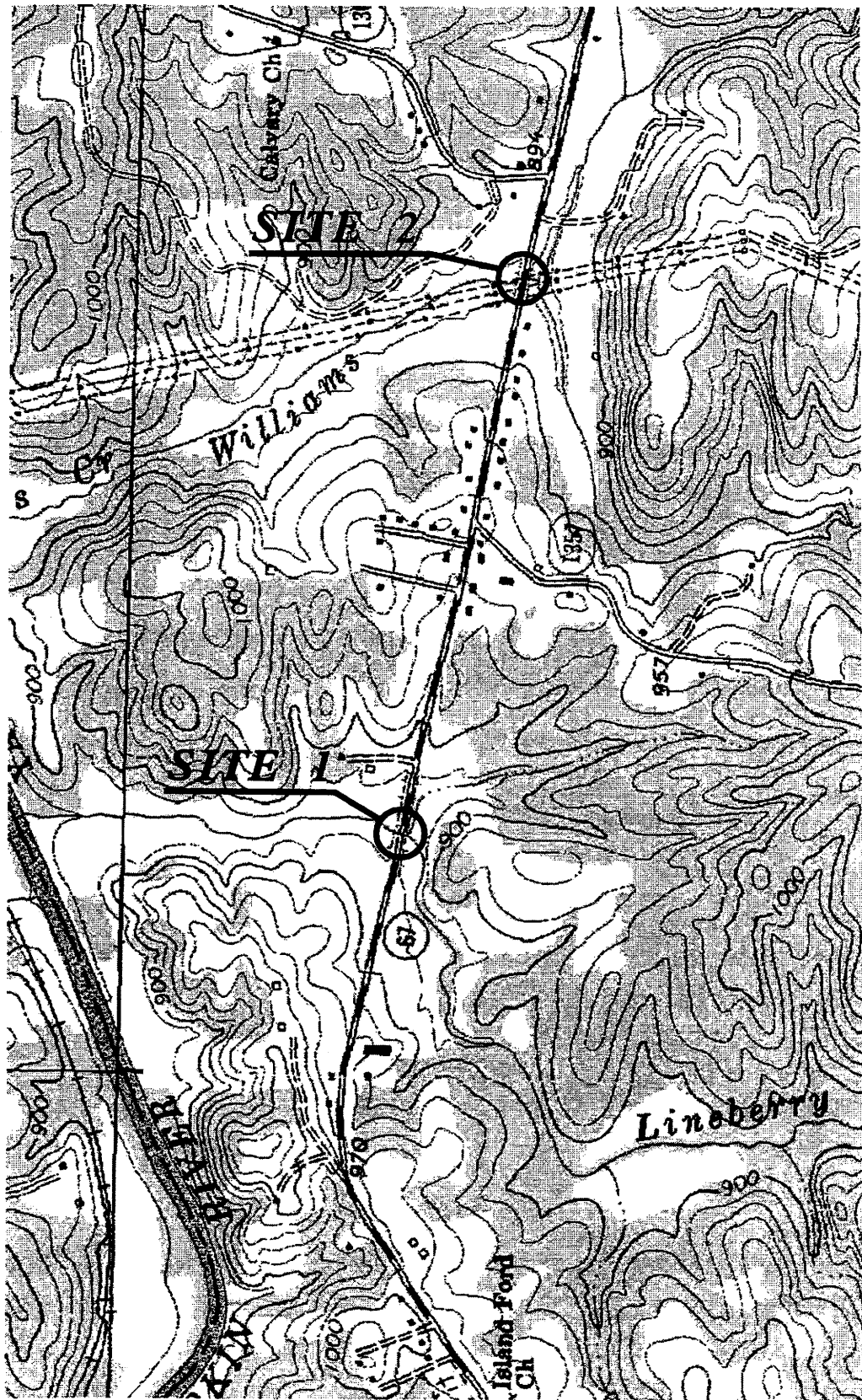

**SITE MAPS  
(SITES 1 & 2)**

**DIVISION OF HIGHWAYS  
N.C. DEPT. OF TRANSPORTATION  
YADKIN COUNTY**

**PROJECT: R-3415  
IMPROVEMENT OF NC 67 FROM SR 1355  
(MESSICK) ROAD TO JUST WEST OF  
BOONVILLE**

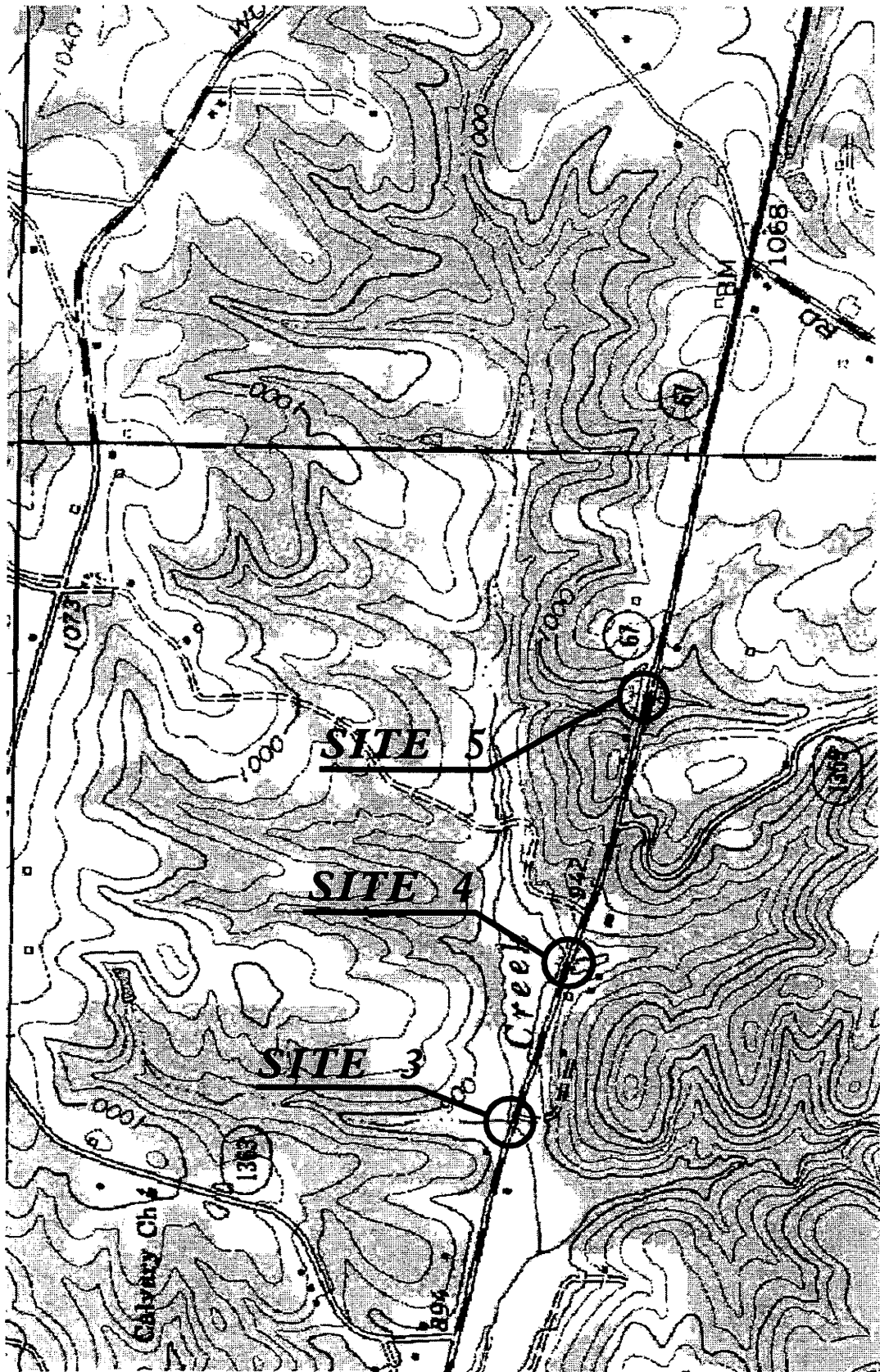

**SITE MAPS  
(SITES 3 - 5)**

**DIVISION OF HIGHWAYS  
N.C. DEPT. OF TRANSPORTATION  
YADKIN COUNTY**

**PROJECT: R-3415  
IMPROVEMENT OF NC 67 FROM SR 1355  
(MESSICK) ROAD TO JUST WEST OF  
BOONVILLE**

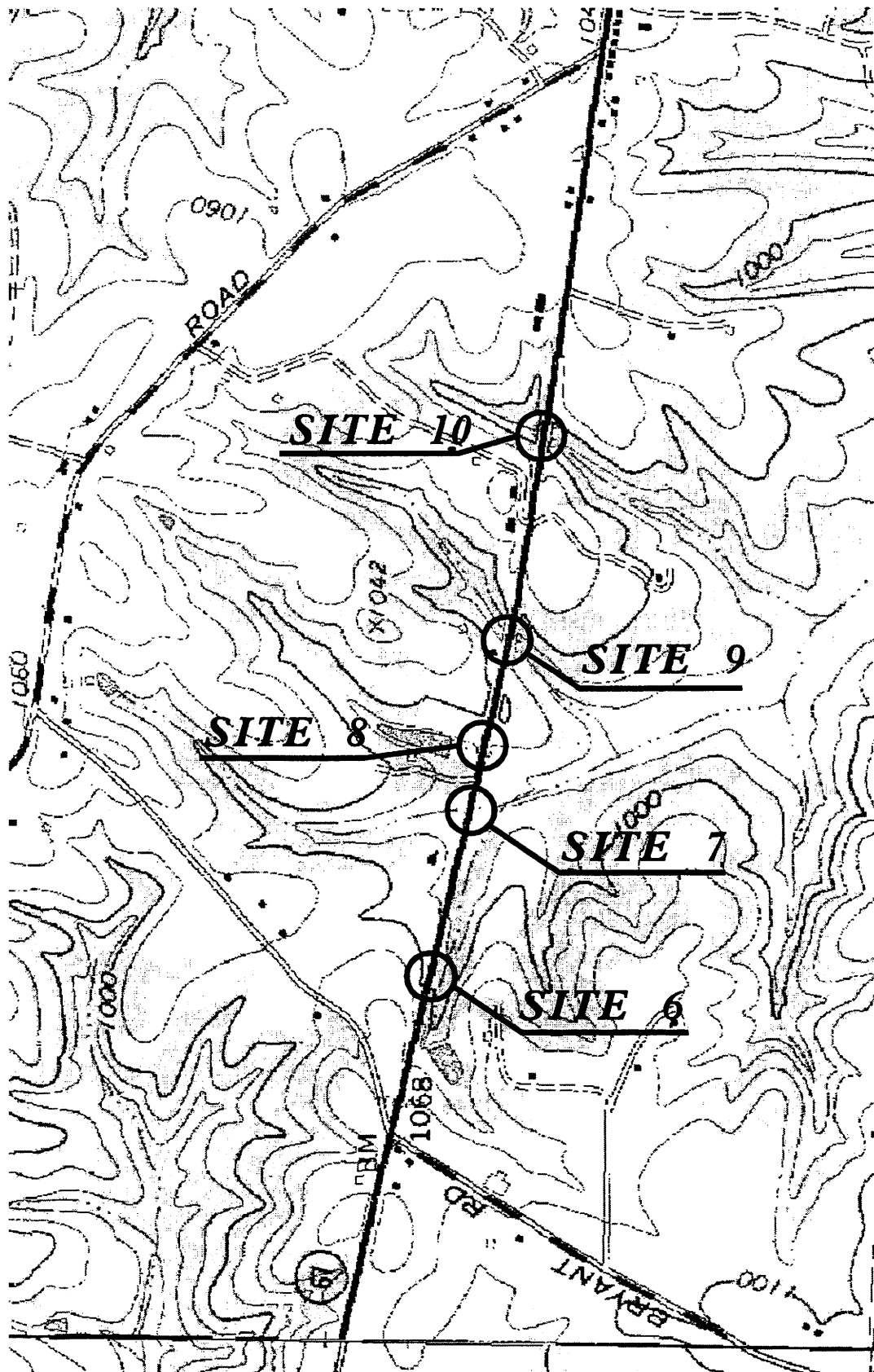

**SITE MAPS  
(SITES 6 - 10)**

**DIVISION OF HIGHWAYS  
N.C. DEPT. OF TRANSPORTATION  
YADKIN COUNTY**

**PROJECT: R-3415  
IMPROVEMENT OF NC 67 FROM SR 1355  
(MESSICK) ROAD TO JUST WEST OF  
BOONVILLE**

# WETLAND PERMIT IMPACT SUMMARY

Site No.	Station (From/To)	Structure (Size/Type)	WETLAND IMPACTS			SURFACE WATER IMPACTS				Natural Stream Design (FT)	
			Fill In Wetlands (Ac)	Temp. Fill In Wetlands (Ac)	Excavation In Wetlands (Ac)	Mechanized Clearing (Method III) (Ac)	Fill In SW (Natural) (Ac)	Temp Exist Channel Impact (FT)	Temp Fill In SW (Ac)		Existing Channel Impact (FT)
1	-L- 79+43.01	EXTEND 309'X15' RCBC					0.014			32'	
	-L- 81+00 RT	LATERAL DITCH CONST.					0.019			325'	
2	-L- 119+06.31	EXTEND 308'X12' RCBC					0.010			28'	
3	-L- 141+90.62	EXTEND 208'X8' RCBC					0.009			32'	
	-L- 141+50 LT	LATERAL DITCH CONST.					0.004			74'	
	-L- 143+00 LT	LATERAL DITCH CONST.					0.018			208'	
4	-L- 153+48	RETAIN, COLLAR & EXTEND EX. 4'X5' RCBC W/ 60' RCP					0.008			60'	
5	-L- 171+37.35	EXTEND 6'X5' RCBC					0.016			38'	
6	-L- 209+25 RT	LATERAL DITCH CONST.					0.010			126'	
7	-L- 209+25 RT	RETAIN & EXTEND EX. 4'X5' RCBC W/ 60' RCP					0.006			48'	
8	-L- 222+41.60	RETAIN & EXTEND EX. 4'X4' RCBC W/ 54' RCP					0.006			49'	
PAGE TOTAL:							0.120			1030	1024

**DIVISION OF HIGHWAYS  
N.C. DEPT. OF TRANSPORTATION  
YADKIN COUNTY**

**PROJECT: R-3415  
IMPROVEMENT OF NC 67 FROM SR 1355  
(MESSICK) ROAD TO JUST WEST OF  
BOONVILLE**

# WETLAND PERMIT IMPACT SUMMARY

Site No.	Station (From/To)	Structure (Size/Type)	WETLAND IMPACTS				SURFACE WATER IMPACTS					
			Fill In Wetlands (Ac)	Temp. Fill In Wetlands (Ac)	Excavation In Wetlands (Ac)	Mechanized Clearing (Method III) (Ac)	Fill In SW (Natural) (Ac)	Temp Exist Channel Impact (Ft)	Temp Fill In SW (Ac)	Existing Channel Impact (Ft)	Natural Stream Design (Ft)	
9	-L- 233+96.76	RETAIN & EXTEND EX. 4'X4' RCBC W/ 54" RCP					0.019				98'	
10	-L- 233+96.76	RETAIN & EXTEND EX. 3'X4' RCBC W/ 48" RCP					0.016				80'	
PAGE TOTAL:							0.035				178'	
PREVIOUS PAGE TOTAL:							0.120				1030' +100'	
PROJECT TOTAL:							0.155				1198' +100'	

**DIVISION OF HIGHWAYS**  
**N.C. DEPT. OF TRANSPORTATION**  
**YADKIN COUNTY**  
  
**PROJECT: R-3415**  
**IMPROVEMENT OF NC 67 FROM SR 1355**  
**(MESSICK) ROAD TO JUST WEST OF**  
**BOONVILLE**  
  
 SHEET 7 OF 28 8/03/04

# PROPERTY OWNER

## NAME AND ADDRESS

PARCEL NO.	OWNER'S NAME	ADDRESS
38	LINDBURG SWAIM & WIFE ANN SWAIM DB 140 PG 244	109 PARK CIRLE DRIVE JONESVILLE, NC 28642
41	JAMIE PHILLIPS & WIFE STEPHANIE PHILLIPS DB 455 PG 238	2439 NC HWY 67 JONESVILLE, NC 28642
42	DENNIS HUTTA & WIFE JOAN HUTTA DB 372 PG 352	2452 NC HWY 67 JONESVILLE, NC 28642
43	MICKEY P.HOLCOMB DB 415 PG 469	2517 NC HWY 67 JONESVILLE, NC 28642
68	J.A. WILLIAMS FARMS, INC. DB 114 PG 508 DB 316 PG 144	3744 WOODRUFF ROAD JONESVILLE, NC 28642
69	TONY MUNCUS & WIFE ALYCE MUNCUS DB 438 PG 293	905 DINKINS ROAD LEWISVILLE, NC 27023
70	MARIE VESTAL DB 248 PG 57	3904 VESTAL ROAD JONESVILLE, NC 28642
77	JOHN WRENN & WIFE RHONDA WRENN DB 287 PG 308	2925 NC HWY 67 JONESVILLE, NC 28642
78	WALTER SMITH & WIFE NELLIE SMITH DB 287 PG 308	2944 NC HWY 67 JONESVILLE, NC 28642
79	FAITH TABERNACLE CHURCH (C/O WILLIAM A. JONES DB 374 PG 340	3925 GOLF COURSE ROAD BOONVILLE, NC 27011
81	JOHNNY SHEW & WIFE KARON SHEW DB 304 PG 177	3016 NC HWY 67 JONESVILLE, NC 28642

**DIVISION OF HIGHWAYS  
N.C. DEPT. OF TRANSPORTATION  
YADKIN COUNTY**

**PROJECT: R-3415  
IMPROVEMENT OF NC 67 FROM SR 1355  
(MESSICK ROAD) TO JUST WEST OF  
BOONVILLE**



# PROPERTY OWNER

## NAME AND ADDRESS

PARCEL NO.	OWNER'S NAME	ADDRESS
82	KENNETH VANHOY DB 287 PG 310 DB 117 PG 184 DB 88 PG 311	3028 NC HWY 67 JONESVILLE, NC 28642
83	KENNETH WHITLOCK & WIFE JANIE WHITLOCK DB 412 PG 379	7687 GRAPEVINE ROAD LEWISVILLE, NC 27023
86	THOMAS M. POPLIN DB 315 PG 473	2000 THORTON PLACE JONESVILLE, NC 28642
87	WALTER BROWN & WIFE JOAN BROWN DB 236 PG 137	1216 HENRY STREET YADKINVILLE, NC 27055
88	DALE & LYNN ROSE & FOY DEAN DAVIS. DB 495 PG 885	WOODRUFF RD BOONVILLE, NC 27011
90	JUANITA BRYANT, ETAL. WB 8 PG 304 WB 70E PG 18	4021 BRYANT ROAD BOONVILLE, NC 27011
91	JAMES KNIGHT & AMY KNIGHT DB 512 PG 167	3541 NC HWY 67 BOONVILLE, NC 27011
92	ROY W. REECE DB 48 PG 20	P.O. BOX 127 BOONVILLE, NC 27011
93	LARRY WHITT, JAMES KNIGHT, & AMY KNIGHT DB 295 PG 378	3541 NC HWY 67 BOONVILLE, NC 27011
95	NANCY C. WOOTEN, BILLY COLLINS, & THOMAS COLLINS, JR. DB 75 PG 62	718 MAPLEWOOD LN. STATESVILLE, NC 28625
97	VAUGHAN BASSETT FURNITURE CO. DB 415 PG 820	403 E. MAIN STREET ELKIN, NC 28621
98	JOHN COLLINS & WIFE RUTH COLLINS DB 62 PG 334	3836 NC HWY 67 BOONVILLE, NC 27011

**DIVISION OF HIGHWAYS  
N.C. DEPT. OF TRANSPORTATION  
YADKIN COUNTY**

**PROJECT: R-3415  
IMPROVEMENT OF NC 67 FROM SR 1355  
(MESSICK ROAD) TO JUST WEST OF  
BOONVILLE**

# WETLAND PERMIT IMPACT SUMMARY

Site No.	Station (From/To)	Structure (Size/Type)	WETLAND IMPACTS				SURFACE WATER IMPACTS				
			Fill In Wetlands (Ac)	Temp. Fill In Wetlands (Ac)	Excavation In Wetlands (Ac)	Mechanized Clearing (Method III) (Ac)	Fill In SW (Natural) (Ac)	Temp Exist Channel Impact (Ft)	Temp Fill In SW (Ac)	Existing Channel Impact (Ft)	Natural Stream Design (Ft)
1	-L- 79+43.01	EXTEND 368'X18' RCBC					0.014	65'	0.014'	32'	
	-L- 81+00 RT	LATERAL DITCH CONST.					0.019			325'	
2	-L- 119+06.31	EXTEND 368'X18' RCBC					0.010	80'	0.021	28'	
3	-L- 141+80.62	EXTEND 288'X8' RCBC					0.009	60'	0.006	46'	
	-L- 141+50 LT	LATERAL DITCH CONST.					0.004			74'	
	-L- 143+00 LT	LATERAL DITCH CONST.					0.018			208'	
4	-L- 153+48	RETAIN, COLLAR & EXTEND EX. 4'X5' RCBC W/ 60" RCP					0.008			60'	
5	-L- 171+37.35	EXTEND 6'X5' RCBC					0.016	55'	0.004	38'	
6	-L- 209+25 RT	LATERAL DITCH CONST.					0.010			126'	
7	-L- 209+25 RT	RETAIN & EXTEND EX. 4'X5' RCBC W/ 60" RCP					0.006			48'	
8	-L- 222+41.60	RETAIN & EXTEND EX. 4'X5' RCBC W/ 54" RCP					0.006			49'	
PAGE TOTAL							0.180	260'	0.045	1034'	

**DIVISION OF HIGHWAYS  
N.C. DEPT. OF TRANSPORTATION  
YADKIN COUNTY**

**PROJECT: R-3415  
IMPROVEMENT OF NC 67 FROM SR 1355  
(MESSICK) ROAD TO JUST WEST OF  
BOONVILLE**

# WETLAND PERMIT IMPACT SUMMARY

Site No.	Station (From/To)	Structure (Size/Type)	WETLAND IMPACTS				SURFACE WATER IMPACTS								
			Fill in Wetlands (Ac)	Temp. Fill in Wetlands (Ac)	Excavation in Wetlands (Ac)	Mechanized Clearing (Method III) (Ac)	Fill in SW (Natural) (Ac)	Temp Exlet Channel Impact (FT)	Temp Fill in SW (Ac)	Existing Channel Impact (FT)	Natural Stream Design (FT)				
9	-L- 233+96.76	RETAIN & EXTEND EX. 4'X4' RCBC W/ 54" RCP					0.019			96'					
10	-L- 233+96.76	RETAIN & EXTEND EX. 3'X4' RCBC W/ 48" RCP					0.016			80'					
PAGE TOTAL:							0.035						178'		
PREVIOUS PAGE TOTAL:							0.120						260'		1034'
PROJECT TOTAL:							0.155						260'		1212'

**DIVISION OF HIGHWAYS**  
**N.C. DEPT. OF TRANSPORTATION**  
**YADKIN COUNTY**  
 PROJECT: R-3415  
 IMPROVEMENT OF NC 67 FROM SR 1355  
 (MESSICK) ROAD TO JUST WEST OF  
 BOONVILLE  
 SHEET 7 OF 28 rev. 4/27/05 8/03/04

STATE	STATE PROJECT REFERENCE NO.	SHEET NO.	TOTAL SHEETS
N.C.	R-3415	1	
STATE PROJ. NO.	F.A. PROJ. NO.	DESCRIPTION	
34541.1.1		P.E.	
34541.2.1		RW & UTILITIES	
34541.3.1		CONSTR.	

Sheet 10 of 28

STATE OF NORTH CAROLINA  
DIVISION OF HIGHWAYS

**YADKIN**

LOCATION: NC 67 FROM SR 1355 (MESSICK ROAD)  
TO JUST WEST OF BOONVILLE

TYPE OF WORK: GRADING, PAVING, WIDENING, AND DRAINAGE

See Sheet 1-A For Index of Sheets

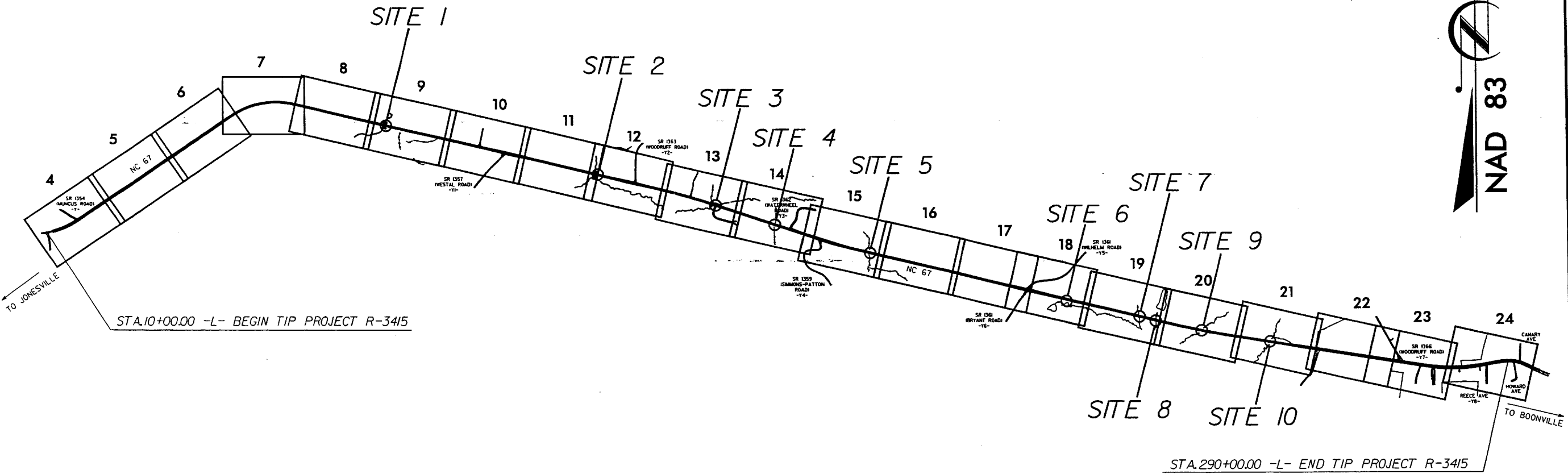
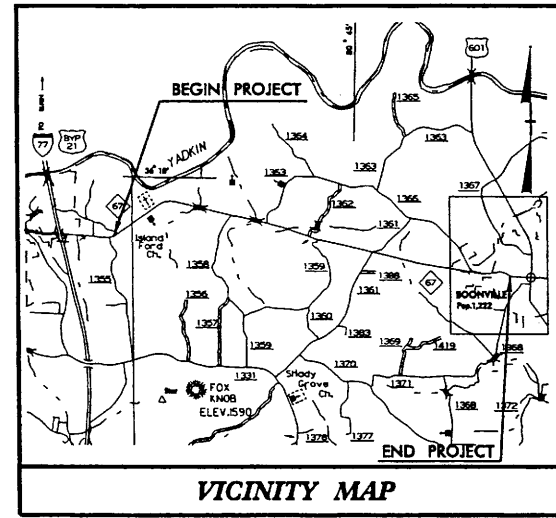

METHOD III CLEARING

PERMIT DRAWINGS 8/03/04

PRELIMINARY PLANS  
DO NOT USE FOR CONSTRUCTION

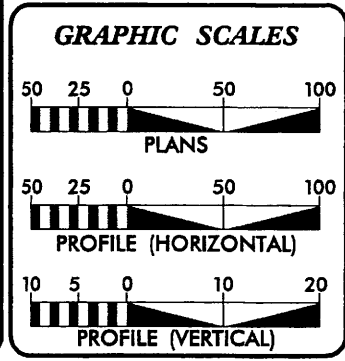

DESIGN DATA

ADT 2000 =	7600
ADT 2025 =	13800
DHV =	10 %
D =	60 %
T =	5 % *
V =	50 MPH
* TTST 2 %	DUAL 3 %

PROJECT LENGTH

LENGTH ROADWAY TIP PROJECT R-3415 =	5.303 MILES
TOTAL LENGTH TIP PROJECT R-3415 =	5.303 MILES

Prepared in the Office of:  
**DIVISION OF HIGHWAYS**  
801 Statesville Rd., North Wilkesboro, NC 28659

2002 STANDARD SPECIFICATIONS

RIGHT OF WAY DATE:  
AUGUST 21, 2003

LETTING DATE:  
MARCH 15, 2005

DIVISION ENGINEER  
R.C. McCANN, PE

SIGNATURE: \_\_\_\_\_ P.E.  
DATE: \_\_\_\_\_

DIVISION OPERATIONS ENGINEER  
W.O. ATKINS, PE

SIGNATURE: \_\_\_\_\_ P.E.  
DATE: \_\_\_\_\_

DIVISION DESIGN ENGINEER  
JOSEPH L. LAWS, PE

SIGNATURE: \_\_\_\_\_ P.E.  
DATE: \_\_\_\_\_

PROJECT: 6.771008 R-3415

09/08/04 15:53 CR:cdw-r-3415-permit-title-sheet.dgn

8/17/99

PROJECT REFERENCE NO. R-3415	SHEET NO. 9
RW SHEET NO.	
ROADWAY DESIGN ENGINEER	HYDRAULICS ENGINEER
PRELIMINARY PLANS DO NOT USE FOR CONSTRUCTION	

Sheet 11 of 28  
rev. 4/27/05

**NOTE**  
FOR -L- PROFILE SEE SHEETS 27,28  
ALL DRIVEWAY RADII ARE 15' UNLESS NOTED

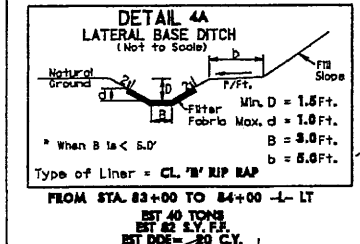
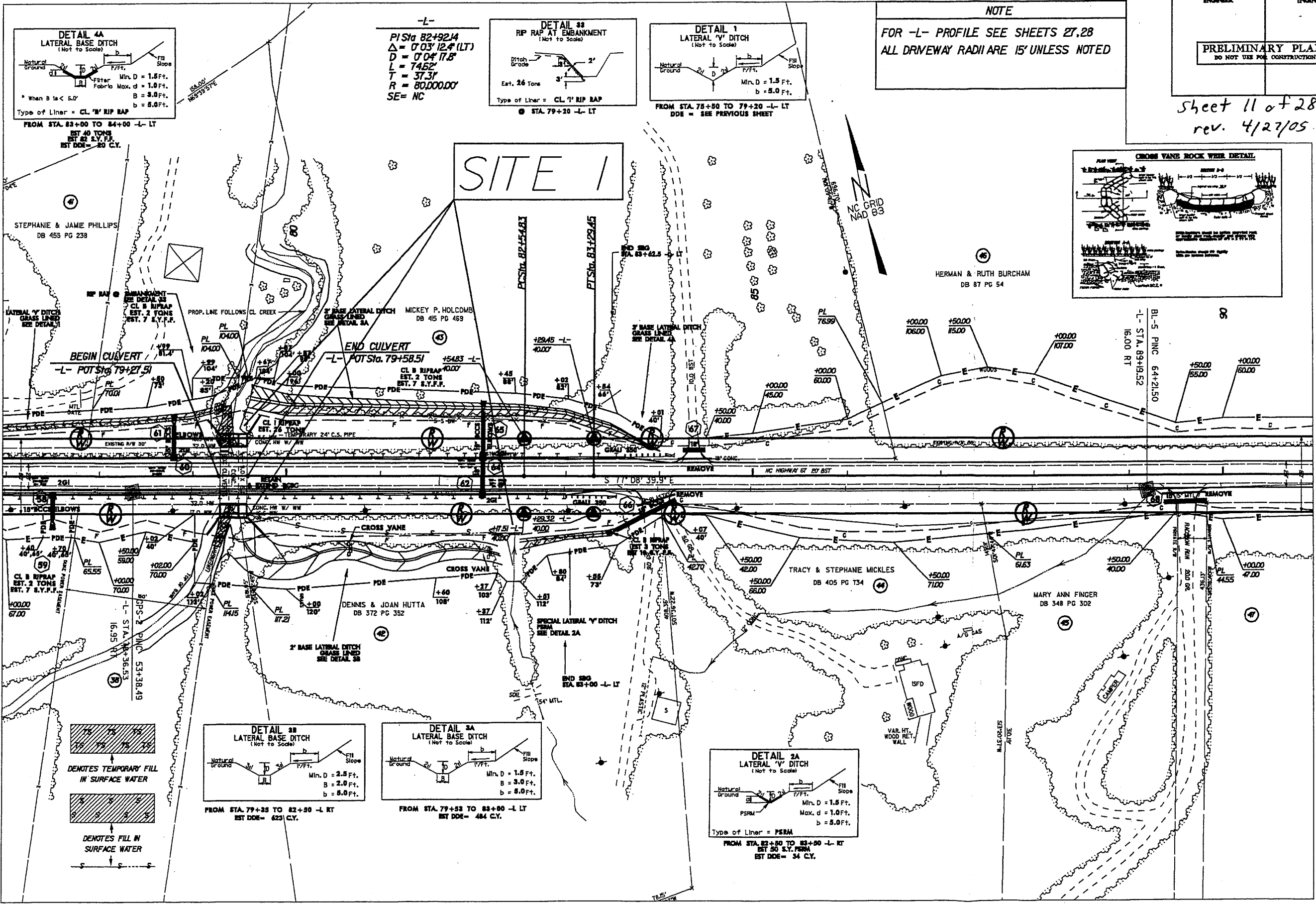

-L-  
PI Sta 82+92.14  
 $\Delta = 0'03'12.4''$  (LT)  
D = 0'04'17.5''  
L = 74.62'  
T = 37.3'  
R = 80,000.00'  
SE = NC

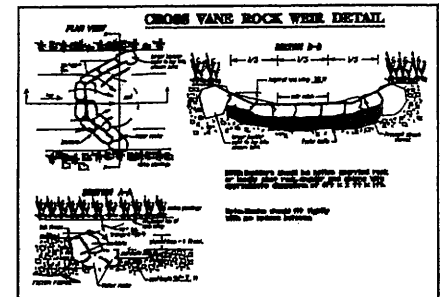
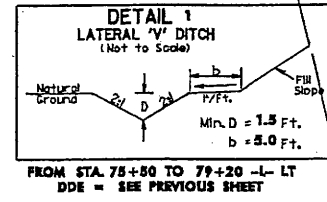
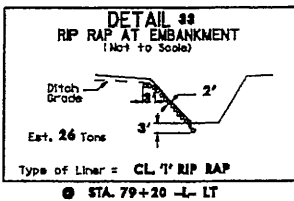

MATCH LINE SHEET 8

MATCH LINE SHEET 10

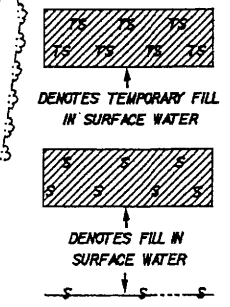
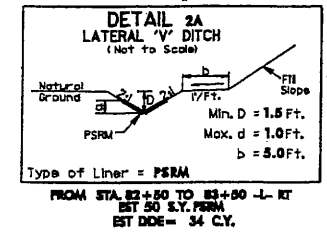
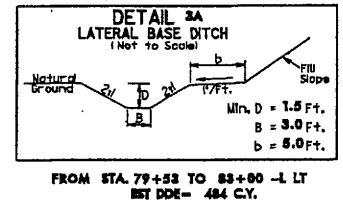
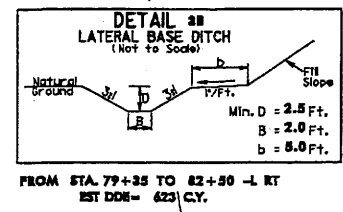

27-APR-2005 15:17  
C:\NAD\27-3415\27-3415.dwg  
C:\NAD\27-3415\27-3415.dgn  
C:\NAD\27-3415\27-3415.dgn

Sheet 12 of 28  
rev. 4/27/05

**NOTE**  
FOR -L- PROFILE SEE SHEETS 27,28  
ALL DRIVEWAY RADII ARE 15' UNLESS NOTED

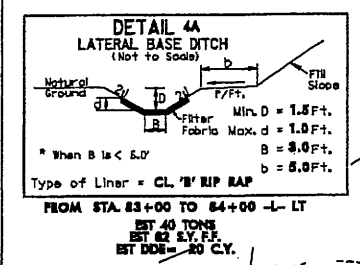

-L-  
PI Sta 82+92.4  
 $\Delta = 0'03'12.4''$  (LT)  
D = 0'04'17.8''  
L = 746.2'  
T = 37.3'  
R = 80,000.00'  
SE = NC

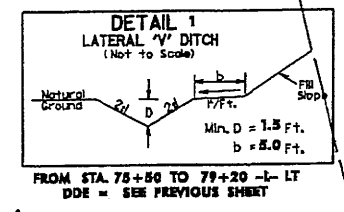
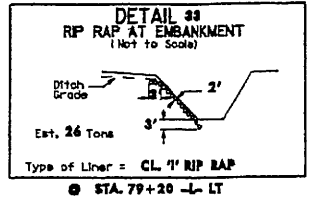

MATCH LINE SHEET 8

MATCH LINE SHEET 10

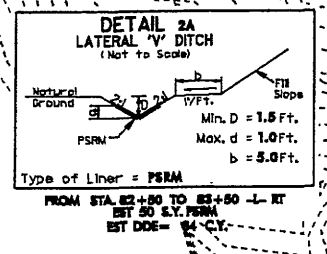
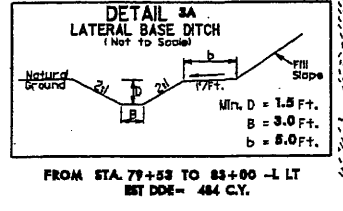
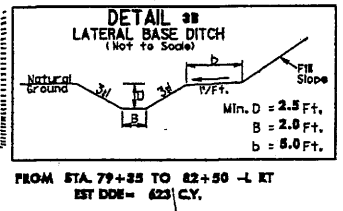
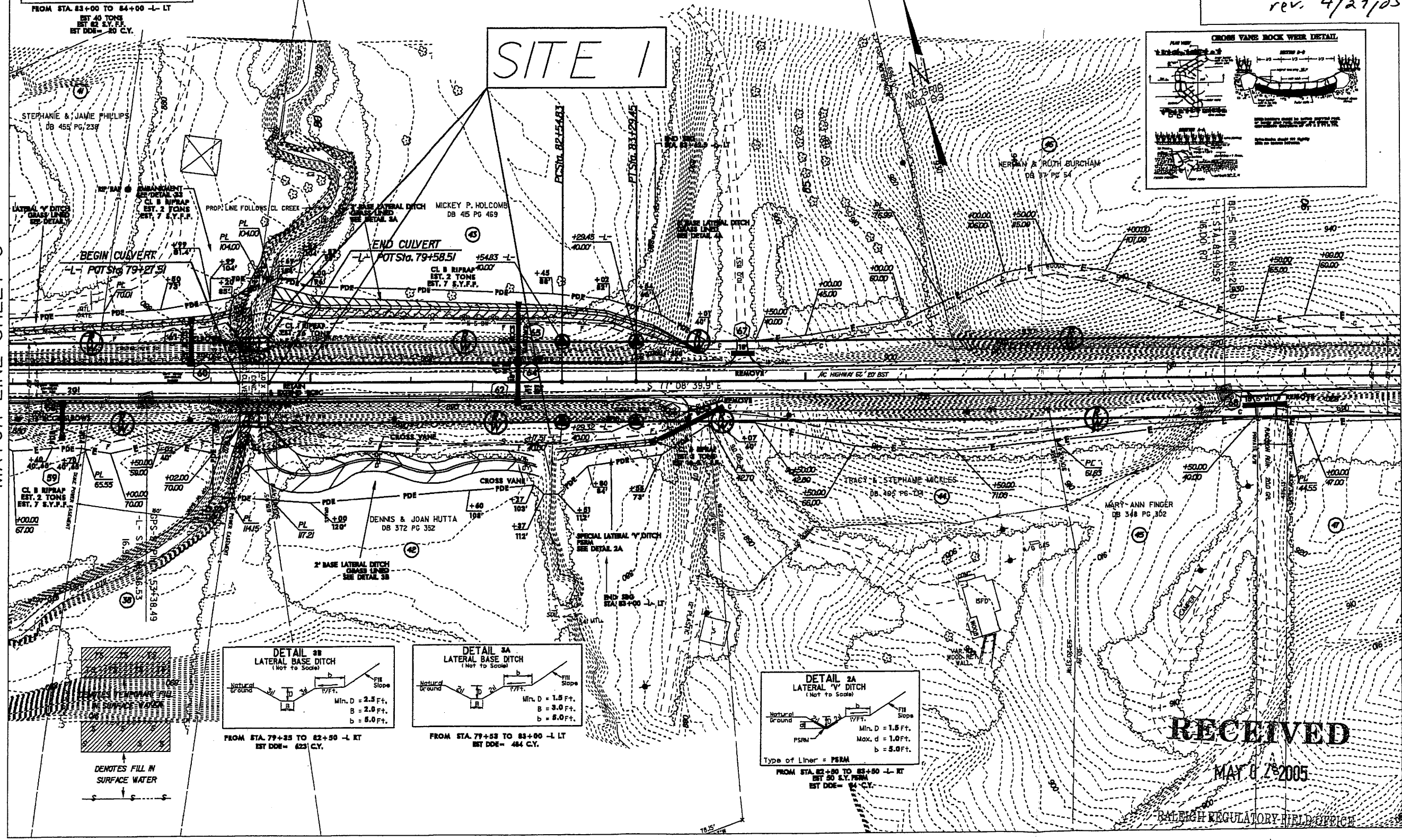

↑  
DENOTES FILL IN  
SURFACE WATER

**RECEIVED**  
MAY 10 2005  
RALEIGH REGULATORY FIELD OFFICE

8/17/99  
27-APR-2005 15:18  
c:\p\d\p-3415\152902 permit.sate\1.dgn  
c:\p\d\p-3415\152902 permit.sate\1.dgn



PROJECT REFERENCE NO. R-3415	SHEET NO. 9
R/W SHEET NO.	
ROADWAY DESIGN ENGINEER	HYDRAULICS ENGINEER
<b>PRELIMINARY PLANS</b> DO NOT USE FOR CONSTRUCTION	

Sheet 12 of 28

**NOTE**  
FOR -L- PROFILE SEE SHEETS 27,28  
ALL DRIVEWAY RADII ARE 15' UNLESS NOTED

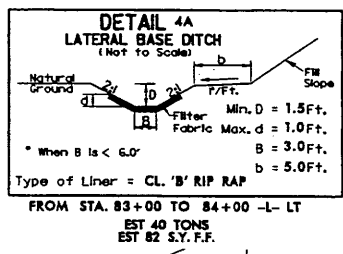

-L-  
PI Sta 82+92.14  
 $\Delta = 0' 03' 12.4" (LT)$   
D = 0' 04' 17.8"  
L = 74.62'  
T = 37.31'  
R = 80,000.00'  
SE =

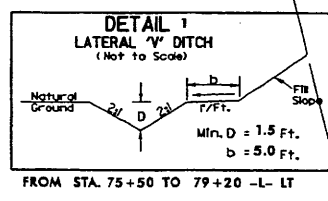
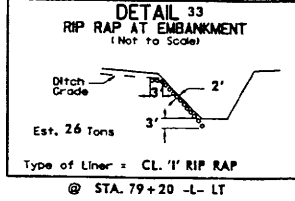

MATCH LINE SHEET 8

MATCH LINE SHEET 10

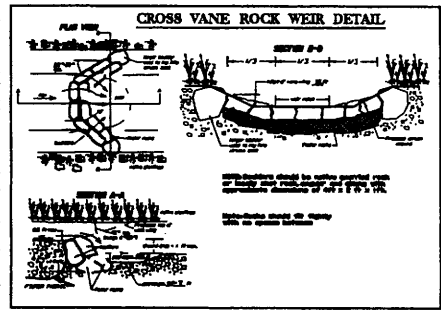
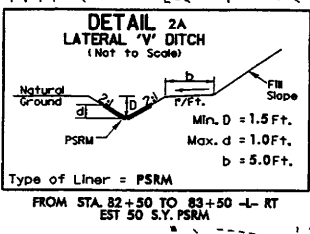
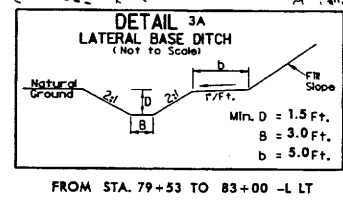
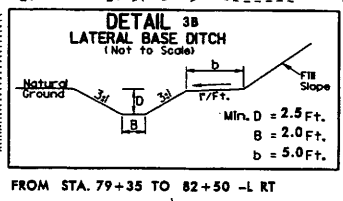
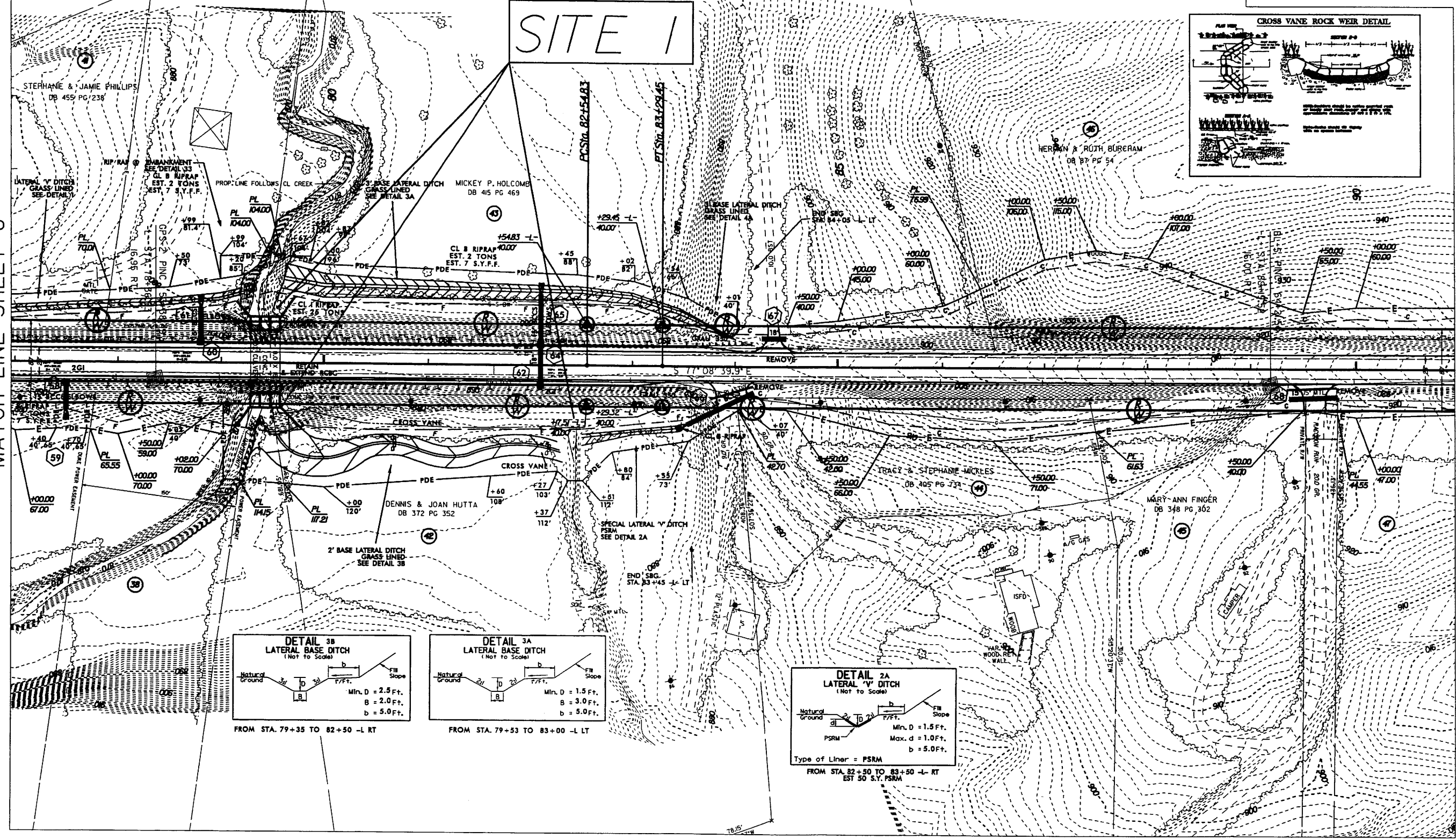

REVISIONS

sheet 13 of 28  
rev. 4/27/05

**NOTE**  
FOR -L- PROFILE SEE SHEET 29  
FOR -D2,D3,D4- PROFILES SEE SHEET 38  
ALL DRIVEWAY RADII ARE 15' UNLESS NOTED

8/17/99

MATCH LINE SHEET II

MATCH LINE SHEET 13

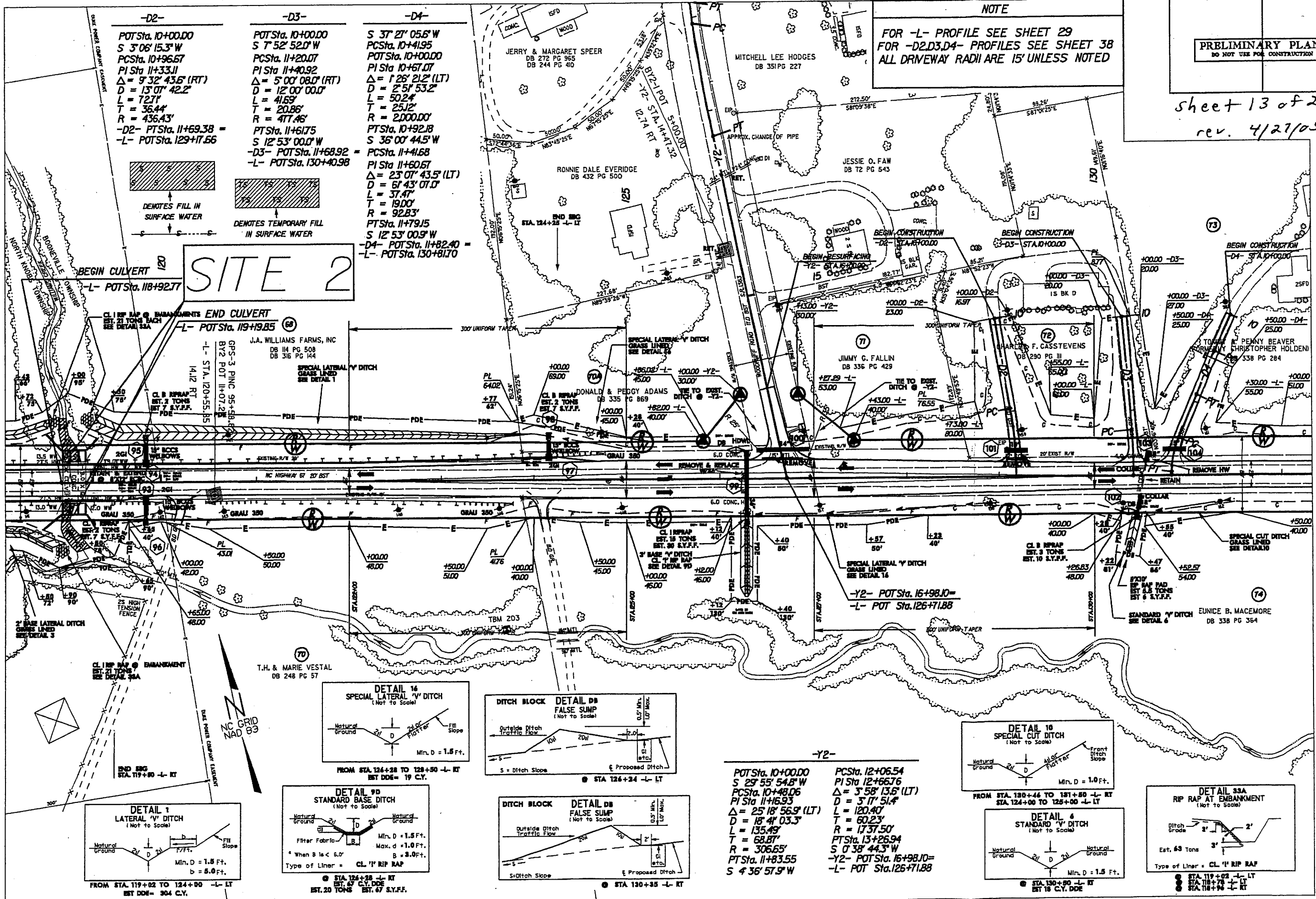

-D2-	-D3-	-D4-
POT Sta. 10+00.00 S 3° 06' 15.3" W PC Sta. 10+96.67 PI Sta. 11+33.11 Δ = 9° 32' 43.6" (RT) D = 13° 07' 42.2" L = 72.71' T = 36.44' R = 436.43'	POT Sta. 10+00.00 S 7° 52' 52.0" W PC Sta. 11+20.07 PI Sta. 11+40.92 Δ = 5° 00' 08.0" (RT) D = 12° 00' 00.0" L = 41.69' T = 20.86' R = 477.46'	S 37° 27' 05.6" W PC Sta. 10+41.95 POT Sta. 10+00.00 PI Sta. 10+67.07 Δ = 1° 26' 21.2" (LT) D = 2° 51' 53.2" L = 50.24' T = 25.12' R = 2000.00'
-D2- PT Sta. 11+69.38 = -L- POT Sta. 129+17.66	PT Sta. 11+61.75 S 12° 53' 00.0" W -D3- POT Sta. 11+68.92 = -L- POT Sta. 130+40.98	PT Sta. 10+92.18 S 36° 00' 44.5" W PC Sta. 11+41.68 PI Sta. 11+60.67 Δ = 23° 07' 43.5" (LT) D = 61° 43' 07.0" L = 37.47' T = 19.00' R = 92.83'
		PT Sta. 11+79.15 S 12° 53' 00.9" W -D4- POT Sta. 11+82.40 = -L- POT Sta. 130+81.70

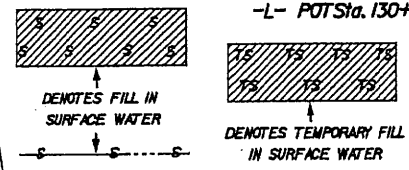

**SITE 2**

BEGIN CULVERT  
-L- POT Sta. 118+92.77

END CULVERT  
-L- POT Sta. 119+19.85

CL 18" RIP RAP  
EST. 2 TONS  
SEE DETAIL 33A

CL 18" RIP RAP  
EST. 2 TONS  
SEE DETAIL 33A

CL 18" RIP RAP  
EST. 2 TONS  
SEE DETAIL 33A

CL 18" RIP RAP  
EST. 2 TONS  
SEE DETAIL 33A

CL 18" RIP RAP  
EST. 2 TONS  
SEE DETAIL 33A

CL 18" RIP RAP  
EST. 2 TONS  
SEE DETAIL 33A

CL 18" RIP RAP  
EST. 2 TONS  
SEE DETAIL 33A

CL 18" RIP RAP  
EST. 2 TONS  
SEE DETAIL 33A

CL 18" RIP RAP  
EST. 2 TONS  
SEE DETAIL 33A

CL 18" RIP RAP  
EST. 2 TONS  
SEE DETAIL 33A

CL 18" RIP RAP  
EST. 2 TONS  
SEE DETAIL 33A

CL 18" RIP RAP  
EST. 2 TONS  
SEE DETAIL 33A

CL 18" RIP RAP  
EST. 2 TONS  
SEE DETAIL 33A

CL 18" RIP RAP  
EST. 2 TONS  
SEE DETAIL 33A

CL 18" RIP RAP  
EST. 2 TONS  
SEE DETAIL 33A

CL 18" RIP RAP  
EST. 2 TONS  
SEE DETAIL 33A

CL 18" RIP RAP  
EST. 2 TONS  
SEE DETAIL 33A

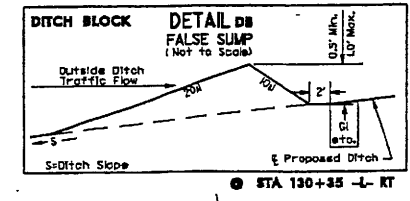
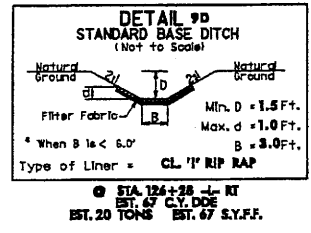
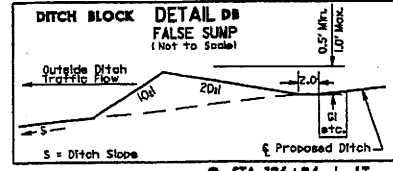
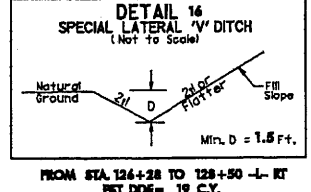

POT Sta. 10+00.00 S 29° 55' 54.8" W PC Sta. 10+48.06 PI Sta. 11+16.93 Δ = 25° 18' 56.9" (LT) D = 15° 41' 03.3" L = 135.49' T = 68.87' R = 306.65'	PC Sta. 12+06.54 PI Sta. 12+66.76 Δ = 3° 58' 13.6" (LT) D = 3° 17' 51.4" L = 120.40' T = 60.23' R = 1737.50'
PT Sta. 11+83.55 S 4° 36' 57.9" W	PT Sta. 13+26.94 S 0° 38' 44.3" W -Y2- POT Sta. 15+98.10 = -L- POT Sta. 126+71.88

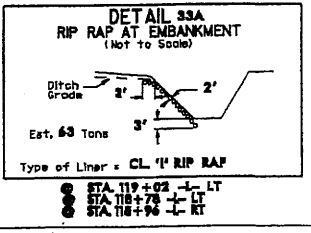
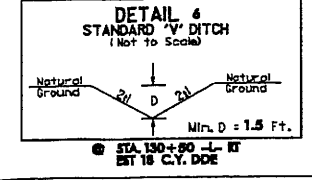
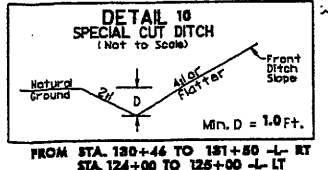

4/28/04 MOVE TO STA. 10+50 -D4- ON PARCEL 73

27 APR 2005 12:15 PM  
C:\D:\PROJECTS\2005\12\15\121528.dwg  
C:\D:\PROJECTS\2005\12\15\121528.dwg



PROJECT REFERENCE NO. R-3415	SHEET NO. 12
RW SHEET NO.	
ROADWAY DESIGN ENGINEER	HYDRAULICS ENGINEER
<b>PRELIMINARY PLANS</b> DO NOT USE FOR CONSTRUCTION	

Sheet 13 of 28

**NOTE**  
FOR -L- PROFILE SEE SHEET 29  
FOR -D2,D3,D4- PROFILES SEE SHEET 38  
ALL DRIVEWAY RADII ARE 15' UNLESS NOTED

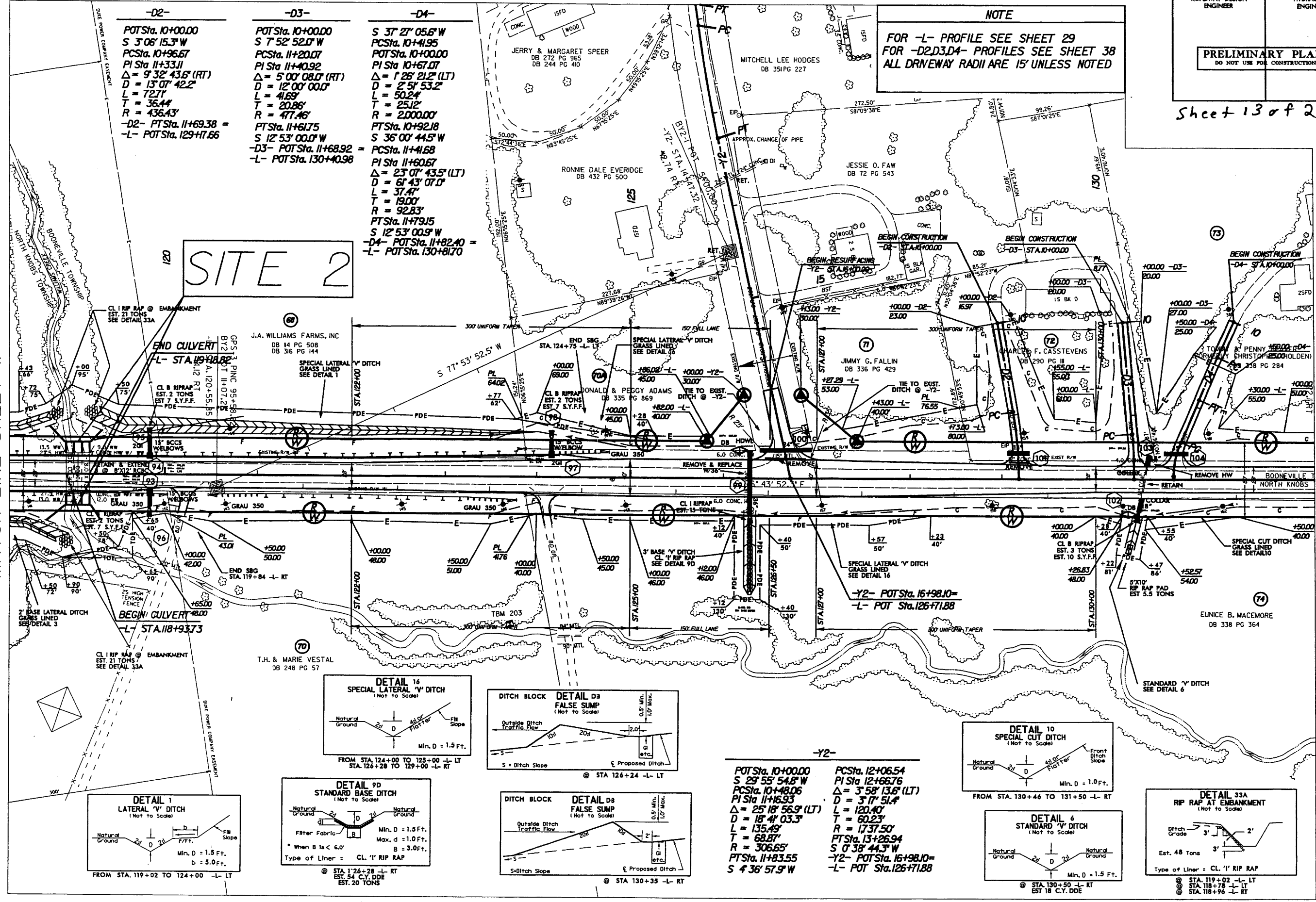

**-D2-**  
POTSta. 10+00.00  
S 3° 06' 15.3" W  
PCSta. 10+96.67  
PISta. 11+33.11  
Δ = 9° 32' 43.6" (RT)  
D = 13° 07' 42.2"  
L = 72.71'  
T = 36.44'  
R = 436.43'  
-D2- POTSta. 11+69.38 =  
-L- POTSta. 129+17.66

**-D3-**  
POTSta. 10+00.00  
S 7° 52' 52.0" W  
PCSta. 11+20.07  
PISta. 11+40.92  
Δ = 5° 00' 08.0" (RT)  
D = 12° 00' 00.0"  
L = 41.69'  
T = 20.86'  
R = 477.46'  
POTSta. 11+61.75  
S 12° 53' 00.0" W  
-D3- POTSta. 11+68.92 =  
-L- POTSta. 130+40.98

**-D4-**  
S 37° 27' 05.6" W  
PCSta. 10+41.95  
POTSta. 10+00.00  
PISta. 10+67.07  
Δ = 1° 26' 21.2" (LT)  
D = 2° 51' 53.2"  
L = 50.24'  
T = 25.12'  
R = 2000.00'  
POTSta. 10+92.18  
S 36° 00' 44.5" W  
PCSta. 11+41.68  
PISta. 11+60.67  
Δ = 23° 07' 43.5" (LT)  
D = 6° 43' 07.0"  
L = 37.47'  
T = 19.00'  
R = 92.83'  
POTSta. 11+79.15  
S 12° 53' 00.9" W  
-D4- POTSta. 11+82.40 =  
-L- POTSta. 130+81.70

**SITE 2**

MATCH LINE SHEET 11

MATCH LINE SHEET 13

4/28/04 MOVE TCE TO STA. 10+50 -D4- ON PARCEL 73

09-DEC-2004 15:49  
C:\p\d\1-3415\ps12-permit.site\*2.dgn  
Lash

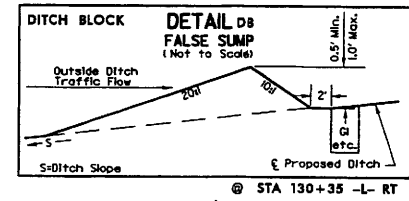
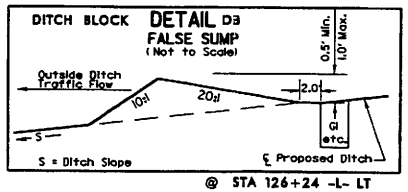
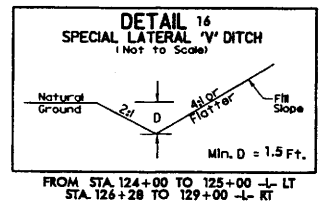
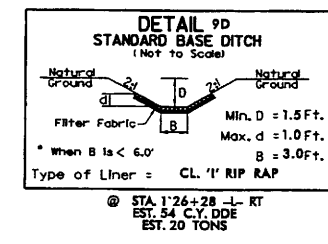
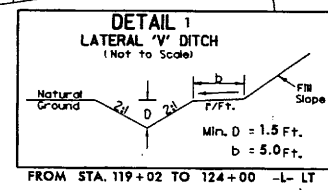

**-Y2-**  
POTSta. 10+00.00  
S 29° 55' 54.8" W  
PCSta. 10+48.06  
PISta. 11+16.93  
Δ = 25° 18' 56.9" (LT)  
D = 18° 41' 03.3"  
L = 135.49'  
T = 68.87'  
R = 306.65'  
POTSta. 11+83.55  
S 4° 36' 57.9" W

PCSta. 12+06.54  
PISta. 12+66.76  
Δ = 3° 58' 13.6" (LT)  
D = 3° 17' 51.4"  
L = 120.40'  
T = 60.23'  
R = 1737.50'  
POTSta. 13+26.94  
S 0° 38' 44.3" W  
-Y2- POTSta. 16+98.10 =  
-L- POTSta. 126+71.88

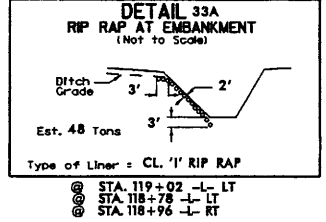
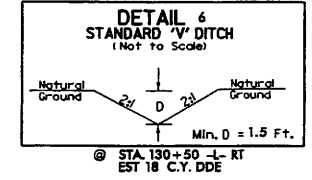
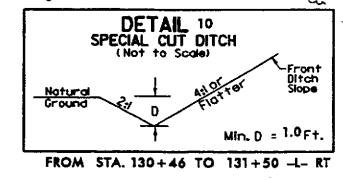

8/17/99

PROJECT REFERENCE NO. R-3415	SHEET NO. 12
RW SHEET NO.	
ROADWAY DESIGN ENGINEER	HYDRAULICS ENGINEER
PRELIMINARY PLANS DO NOT USE FOR CONSTRUCTION	

Sheet 14 of 28  
rev. 4/27/05

NOTE  
FOR -L- PROFILE SEE SHEET 29  
FOR -D2,D3,D4- PROFILES SEE SHEET 38  
ALL DRIVEWAY RADII ARE 15' UNLESS NOTED

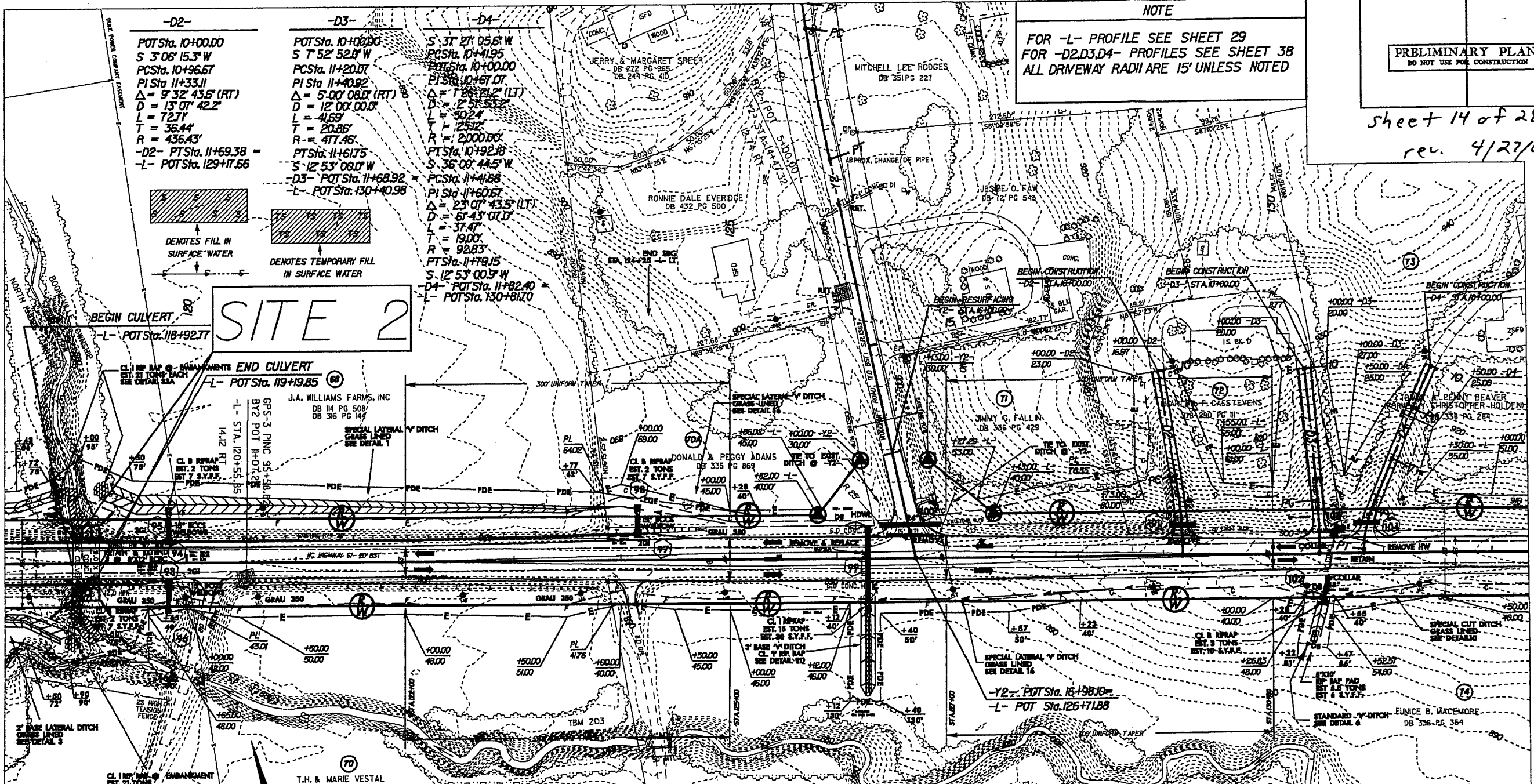

MATCH LINE SHEET II

MATCH LINE SHEET 13

**-D2-**  
 POT Sta. 10+00.00  
 S 3° 06' 15.3" W  
 PCS Sta. 10+196.67  
 PI Sta. 11+33.11  
 $\Delta = 93° 32' 43.6"$  (RT)  
 $D = 13° 07' 42.2"$   
 $L = 72.71'$   
 $T = 36.44'$   
 $R = 436.43'$   
 -D2- POT Sta. 11+69.38 =  
 -L- POT Sta. 129+17.66

**-D3-**  
 POT Sta. 10+00.00  
 S 7° 52' 52.0" W  
 PCS Sta. 11+20.07  
 PI Sta. 11+40.92  
 $\Delta = 5° 00' 08.0"$  (RT)  
 $D = 12° 00' 00.0"$   
 $L = 41.69'$   
 $T = 20.86'$   
 $R = 477.46'$   
 POT Sta. 11+61.75  
 S 12° 53' 09.0" W  
 -D3- POT Sta. 11+68.92 =  
 -L- POT Sta. 130+10.98

**-D4-**  
 S 37° 27' 05.6" W  
 PCS Sta. 10+11.95  
 PI Sta. 10+10.00  
 POTS Sta. 10+67.07  
 $\Delta = 1° 26' 21.2"$  (LT)  
 $D = 2° 58' 53.2"$   
 $L = 30.24'$   
 $T = 25.92'$   
 $R = 2000.00'$   
 POT Sta. 10+92.18  
 S 36° 00' 44.5" W  
 PCS Sta. 11+41.88  
 PI Sta. 11+60.67  
 $\Delta = 23° 07' 43.5"$  (LT)  
 $D = 61° 43' 01.0"$   
 $L = 37.47'$   
 $T = 19.00'$   
 $R = 92.83'$   
 POT Sta. 11+79.15  
 S 12° 53' 00.9" W  
 -D4- POT Sta. 11+82.40 =  
 -L- POT Sta. 130+16.10

SITE 2

BEGIN CULVERT  
-L- POT Sta. 118+92.77

END CULVERT  
-L- POT Sta. 119+19.85

J.A. WILLIAMS FARMS, INC  
 DB 14 PG 508  
 DB 36 PG 144

GPS-3 PINC. 95+18.85  
 BYZ POT 11+07.22  
 STA. 120+55.85

CL 8 W/PAV  
 EST. 2 TONS  
 EST. 7 S.Y.F.F.

CL 8 W/PAV  
 EST. 2 TONS  
 EST. 7 S.Y.F.F.

CL 8 W/PAV  
 EST. 2 TONS  
 EST. 7 S.Y.F.F.

CL 8 W/PAV  
 EST. 2 TONS  
 EST. 7 S.Y.F.F.

CL 8 W/PAV  
 EST. 2 TONS  
 EST. 7 S.Y.F.F.

CL 8 W/PAV  
 EST. 2 TONS  
 EST. 7 S.Y.F.F.

CL 8 W/PAV  
 EST. 2 TONS  
 EST. 7 S.Y.F.F.

CL 8 W/PAV  
 EST. 2 TONS  
 EST. 7 S.Y.F.F.

CL 8 W/PAV  
 EST. 2 TONS  
 EST. 7 S.Y.F.F.

CL 8 W/PAV  
 EST. 2 TONS  
 EST. 7 S.Y.F.F.

CL 8 W/PAV  
 EST. 2 TONS  
 EST. 7 S.Y.F.F.

CL 8 W/PAV  
 EST. 2 TONS  
 EST. 7 S.Y.F.F.

CL 8 W/PAV  
 EST. 2 TONS  
 EST. 7 S.Y.F.F.

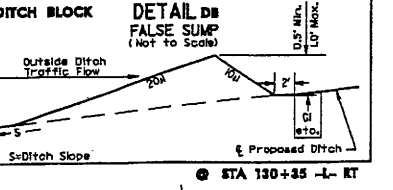
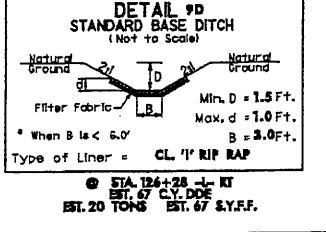
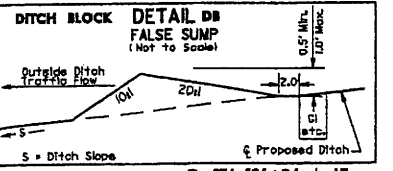
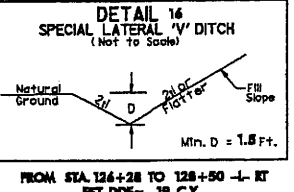

POT Sta. 10+00.00  
 S 29° 55' 54.8" W  
 PCS Sta. 10+148.06  
 PI Sta. 11+16.93  
 $\Delta = 25° 18' 56.9"$  (LT)  
 $D = 18° 41' 03.3"$   
 $L = 135.49'$   
 $T = 68.87'$   
 $R = 306.65'$   
 POT Sta. 11+83.55  
 S 4° 36' 57.9" W

PCS Sta. 12+06.54  
 PI Sta. 12+66.76  
 $\Delta = 3° 58' 13.6"$  (LT)  
 $D = 3° 17' 51.4"$   
 $L = 120.40'$   
 $T = 60.23'$   
 $R = 1737.50'$   
 POT Sta. 13+26.94  
 S 0° 38' 44.3" W  
 -Y2- POT Sta. 16+98.10 =  
 -L- POT Sta. 126+71.88

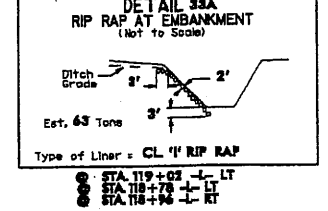
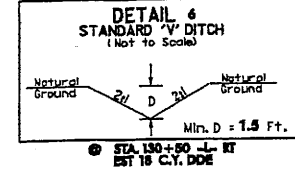
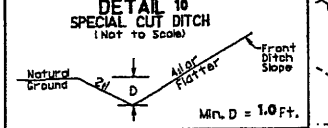

4/28/04 MOVE TCE TO STA. 10+50 -D4- ON PARCEL 73

27-APR-2005 (5:48:41 PM)  
 C:\v-dw\2-3415\12-3415.dwg  
 Author: J. D. DODD  
 Plot: J. D. DODD

sheet 14 of 28

**NOTE**  
 FOR -L- PROFILE SEE SHEET 29  
 FOR -D2,D3,D4- PROFILES SEE SHEET 38  
 ALL DRIVEWAY RADII ARE 15' UNLESS NOTED

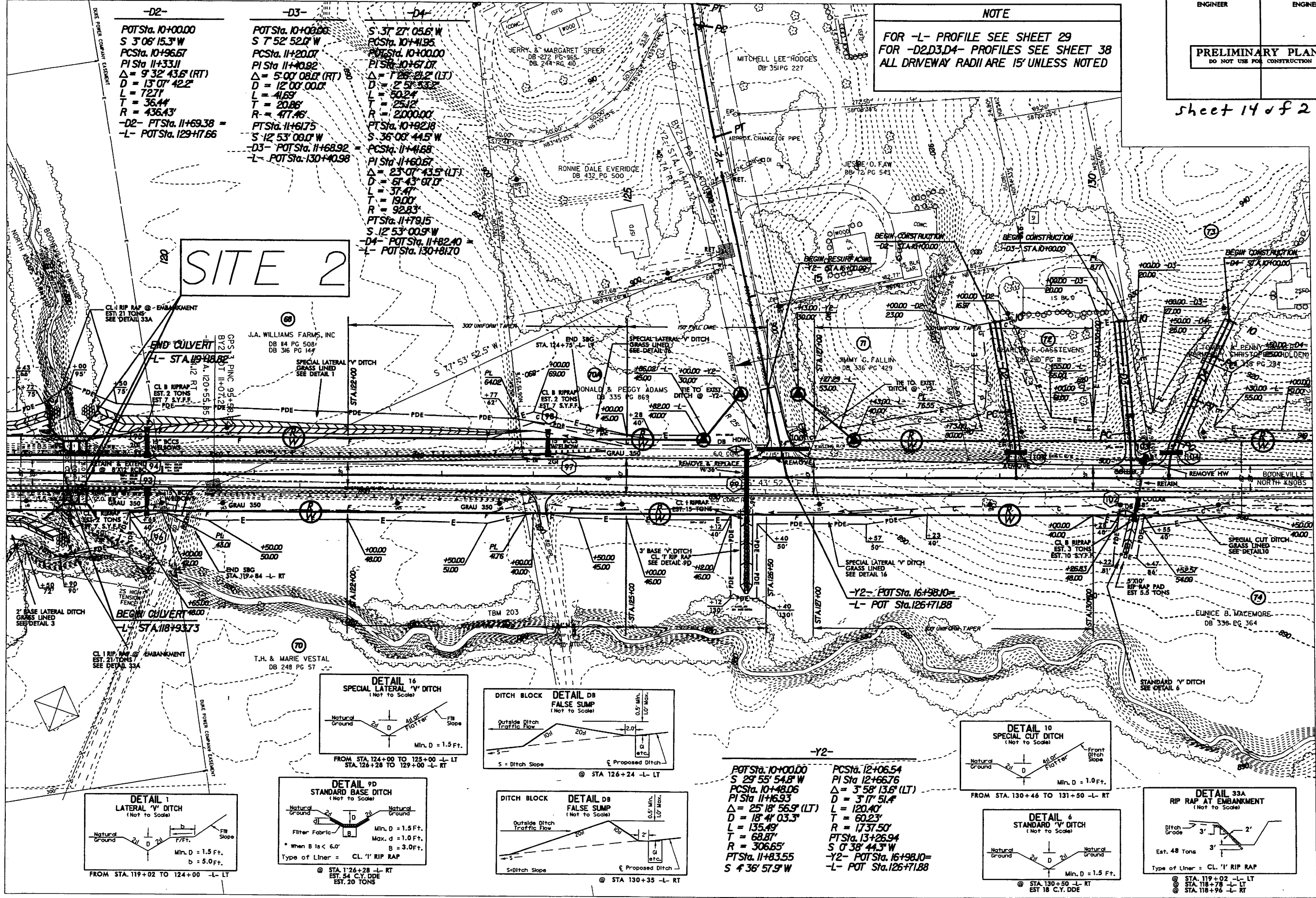

**-D2-**  
 POT Sta. 10+00.00  
 S 3° 06' 15.3" W  
 PCS Sta. 10+96.67  
 PI Sta. 11+33.11  
 $\Delta = 9' 32' 43.6"$  (RT)  
 $D = 13' 07' 42.2"$   
 $L = 72.71'$   
 $T = 36.44'$   
 $R = 436.43'$   
 -D2- PTS Sta. 11+69.38 =  
 -L- POT Sta. 129+17.66

**-D3-**  
 POT Sta. 10+00.00  
 S 7° 52' 52.0" W  
 PCS Sta. 11+20.07  
 PI Sta. 11+40.92  
 $\Delta = 5' 00' 08.0"$  (RT)  
 $D = 12' 00' 00.0"$   
 $L = 41.69'$   
 $T = 20.86'$   
 $R = 477.46'$   
 PTS Sta. 11+61.75  
 S 12° 53' 08.0" W  
 -D3- POT Sta. 11+68.92  
 -L- POT Sta. 130+10.98

**-D4-**  
 S 37° 27' 05.6" W  
 PCS Sta. 10+41.95  
 PI Sta. 10+100.00  
 PI Sta. 10+67.07  
 $\Delta = 1' 28' 21.2"$  (LT)  
 $D = 2' 51' 53.2"$   
 $L = 50.24'$   
 $T = 25.12'$   
 $R = 2000.00'$   
 PTS Sta. 10+82.18  
 S 36° 08' 44.5" W  
 PCS Sta. 11+41.68  
 PI Sta. 11+60.67  
 $\Delta = 23' 07' 43.5"$  (LT)  
 $D = 61' 43' 97.0"$   
 $L = 37.47'$   
 $T = 19.00'$   
 $R = 928.3'$   
 PTS Sta. 11+79.15  
 S 12° 53' 00.9" W  
 -D4- POT Sta. 11+82.40 =  
 -L- POT Sta. 130+81.70

**SITE 2**

MATCH LINE SHEET 11

MATCH LINE SHEET 13

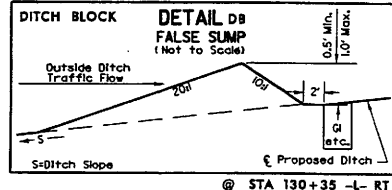
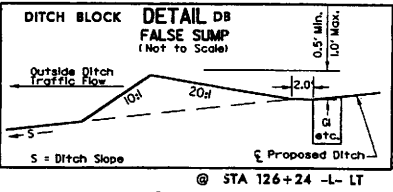
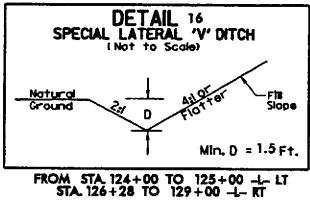
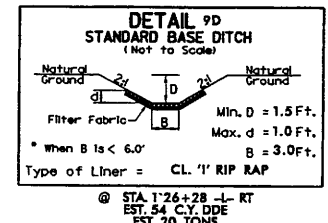
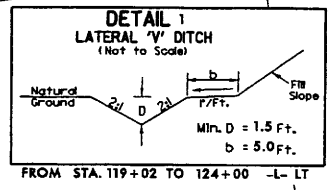

**-Y2-**  
 POT Sta. 10+00.00  
 S 29° 55' 54.8" W  
 PCS Sta. 10+48.06  
 PI Sta. 11+69.93  
 $\Delta = 25' 18' 56.9"$  (LT)  
 $D = 18' 41' 03.3"$   
 $L = 135.49'$   
 $T = 68.87'$   
 $R = 306.65'$   
 PTS Sta. 11+83.55  
 S 4° 36' 57.9" W

PCS Sta. 12+06.54  
 PI Sta. 12+66.76  
 $\Delta = 3' 58' 13.6"$  (LT)  
 $D = 3' 17' 51.4"$   
 $L = 120.40'$   
 $T = 60.23'$   
 $R = 1737.50'$   
 PTS Sta. 13+26.94  
 S 0° 38' 44.3" W  
 -Y2- POT Sta. 16+98.10 =  
 -L- POT Sta. 126+71.88

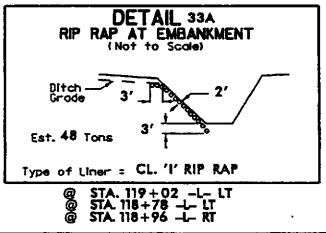
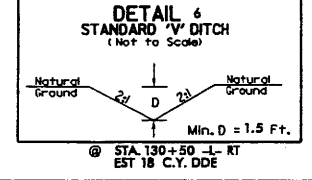
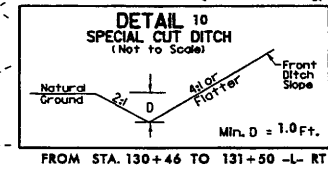

REVISIONS

4/28/04 MOVE TCE TO STA.10+50 -D4- ON PARCEL 73

09-DEC-2004 8:14  
 C:\p\p\3415\3415ps12-permit.site\*2.dgn

8/17/99



PROJECT REFERENCE NO. R-3415	SHEET NO. 13
HW SHEET NO.	
ROADWAY DESIGN ENGINEER	HYDRAULICS ENGINEER
<p align="center"><b>PRELIMINARY PLANS</b> DO NOT USE FOR CONSTRUCTION</p>	

Sheet 15 of 28  
rev. 4/27/05

**NOTE**  
FOR -L- PROFILE SEE SHEETS 29,30  
FOR -D5- PROFILE SEE SHEET 38  
ALL DRIVEWAY RADII ARE 15' UNLESS NOTED

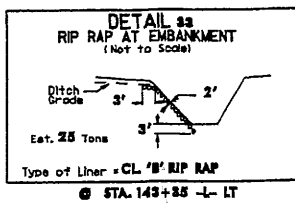

MATCH LINE SHEET 12

MATCH LINE SHEET 14

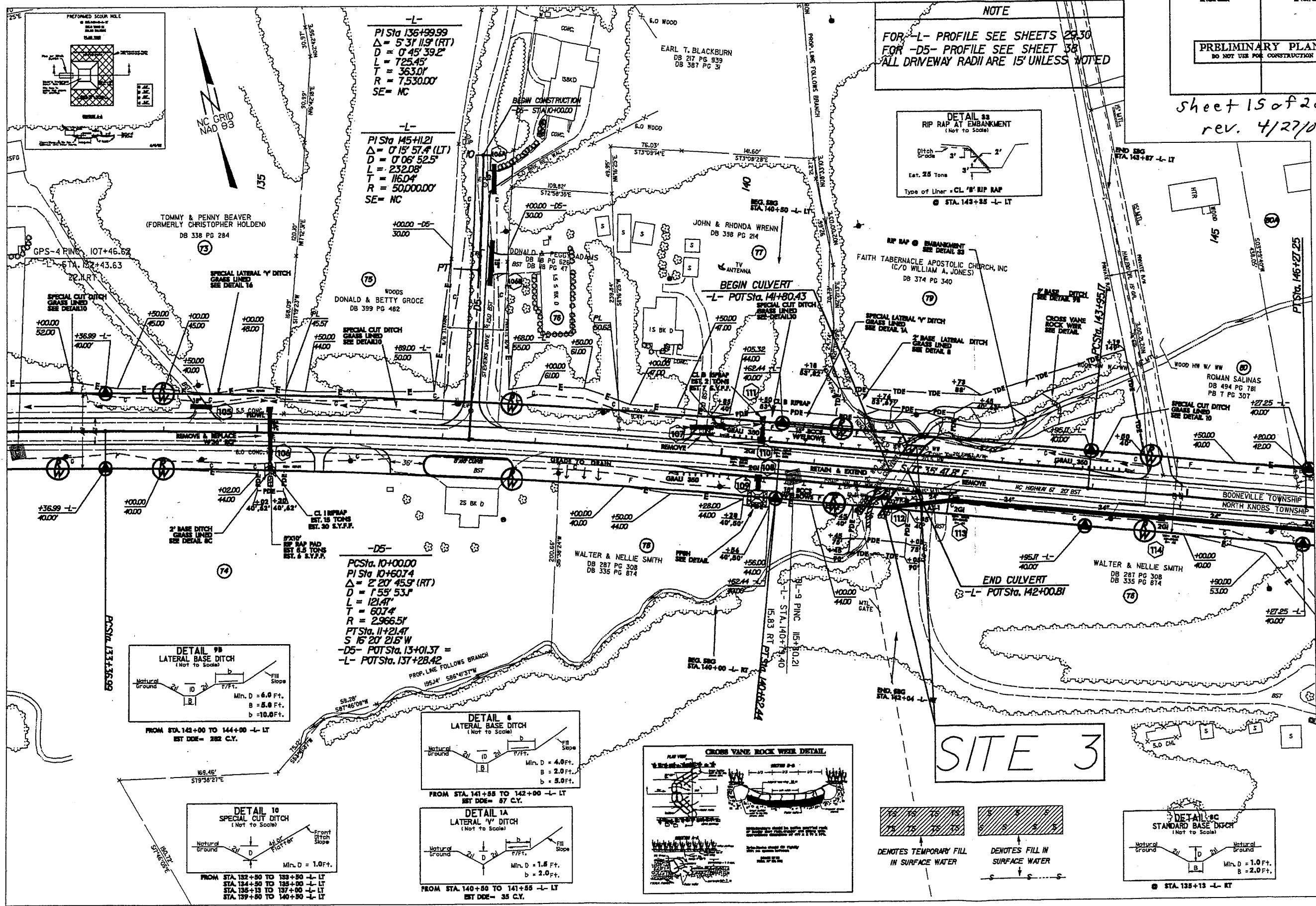

-L-  
PI Sta 136+99.99  
 $\Delta = 5' 31'' 11.9'' (RT)$   
 $D = 0' 45' 39.2''$   
 $L = 725.45'$   
 $T = 363.01'$   
 $R = 7,530.00'$   
SE= NC

-L-  
PI Sta 145+11.21  
 $\Delta = 0' 15' 57.4'' (LT)$   
 $D = 0' 06' 52.5''$   
 $L = 232.08'$   
 $T = 116.04'$   
 $R = 50,000.00'$   
SE= NC

-D5-  
PCSta. 10+00.00  
PI Sta. 10+60.74  
 $\Delta = 2' 20' 45.9'' (RT)$   
 $D = 1' 55' 53.1''$   
 $L = 121.47'$   
 $T = 60.74'$   
 $R = 2,966.51'$   
PT Sta. 11+21.47  
S 16° 20' 21.8" W  
-D5- POT Sta. 13+01.37 =  
-L- POT Sta. 137+28.42

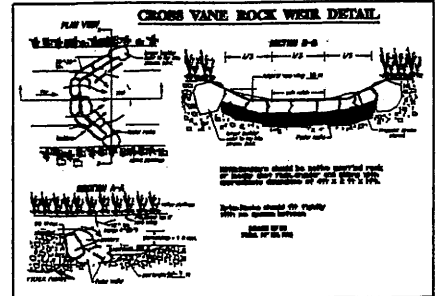
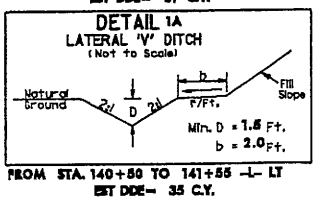
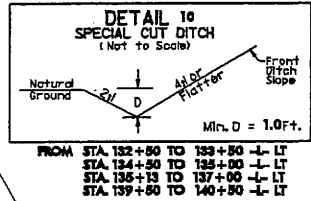
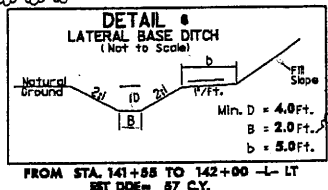
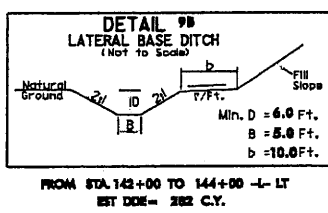

DENOTES TEMPORARY FILL IN SURFACE WATER

DENOTES FILL IN SURFACE WATER

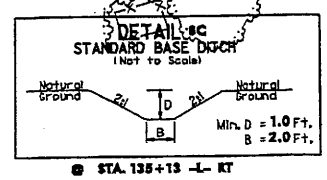

SITE 3

REVISIONS

27-APR-2005 15:17  
C:\pwworkspace\133883188\133883188.dgn  
Created by: [unclear]

PROJECT REFERENCE NO. R-3415	SHEET NO. 13
RW SHEET NO.	
ROADWAY DESIGN ENGINEER	HYDRAULICS ENGINEER
PRELIMINARY PLANS DO NOT USE FOR CONSTRUCTION	

Sheet 15 of 28

**NOTE**  
FOR -L- PROFILE SEE SHEETS 29,30  
FOR -D5- PROFILE SEE SHEET 38  
ALL DRIVEWAY RADII ARE 15' UNLESS NOTED

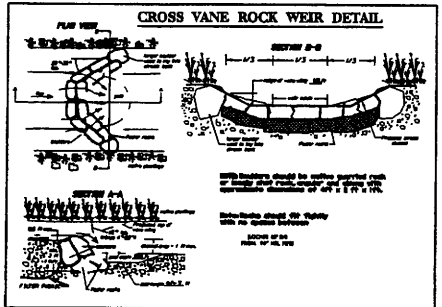
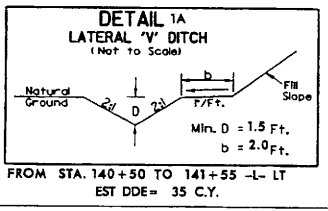
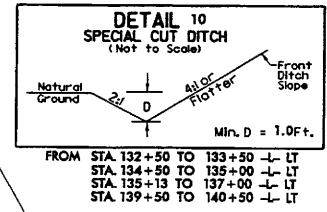
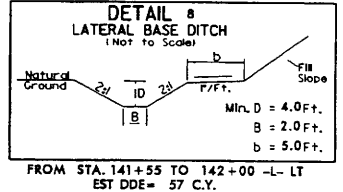
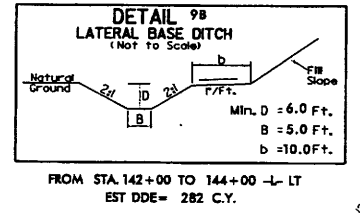
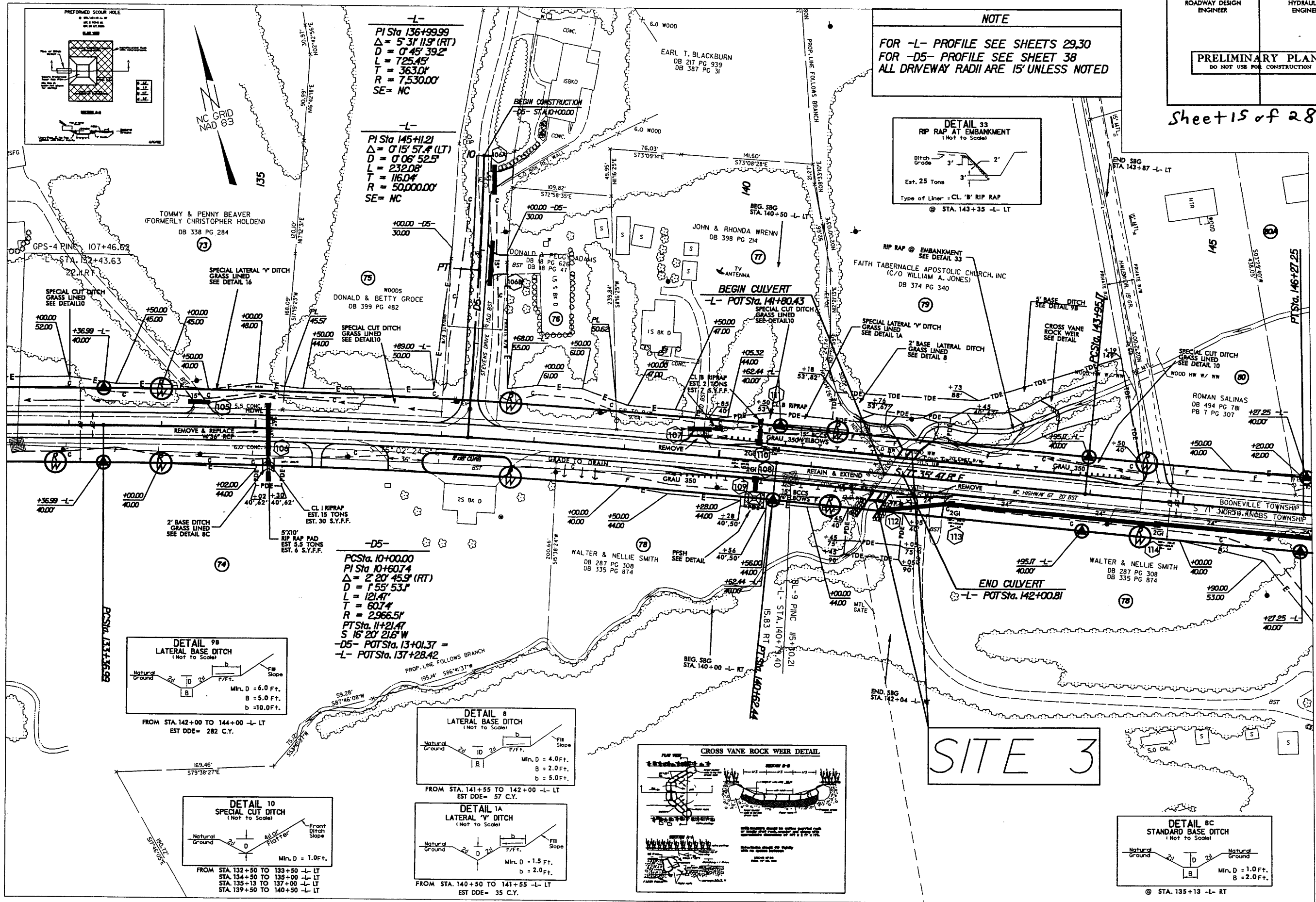
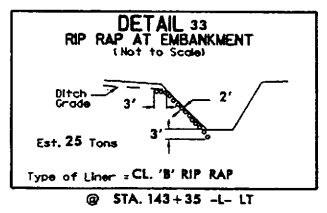

SITE 3

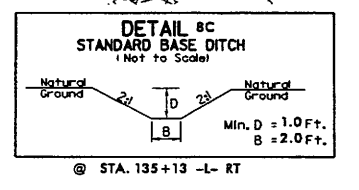

MATCH LINE SHEET 12

MATCH LINE SHEET 14

REVISIONS

03-JAN-2005 14:22  
C:\Users\jv\My Documents\3415\3415.dwg  
3415.dwg

PROJECT REFERENCE NO. R-3415	SHEET NO. 13
HW SHEET NO.	
ROADWAY DESIGN ENGINEER	HYDRAULICS ENGINEER
PRELIMINARY PLANS DO NOT USE FOR CONSTRUCTION	

Sheet 16 of 28  
REV. 4/27/05

B/17/99

MATCH LINE SHEET 12

MATCH LINE SHEET 14

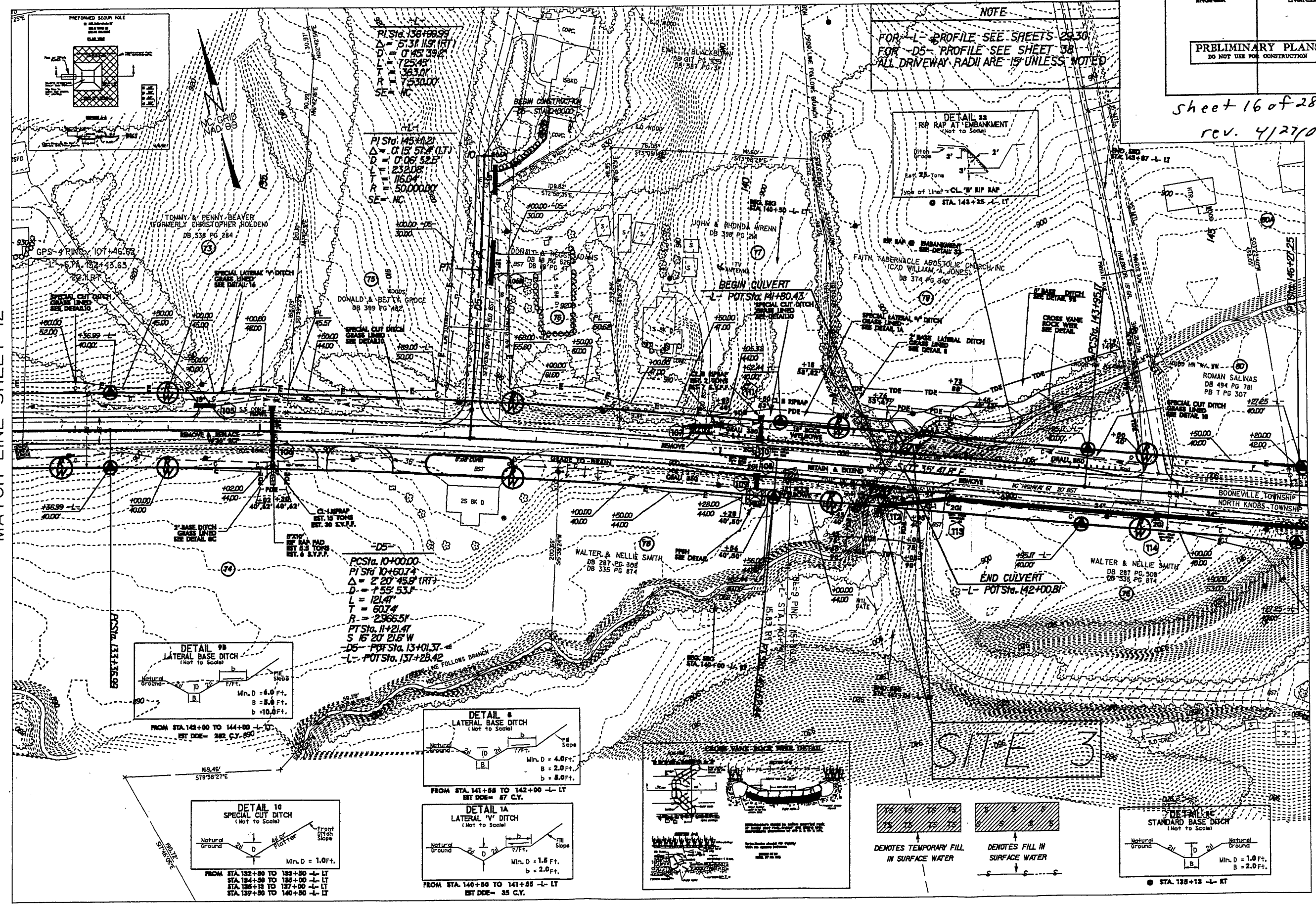

NOTE  
FOR -L- PROFILE SEE SHEETS 25,30  
FOR -D5- PROFILE SEE SHEET 38  
ALL DRIVEWAY RADII ARE 15' UNLESS NOTED

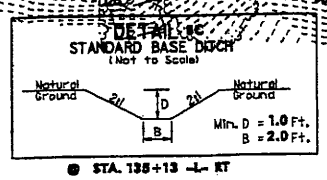
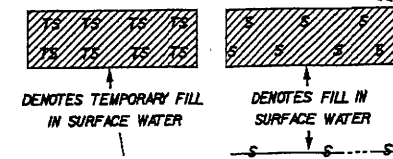
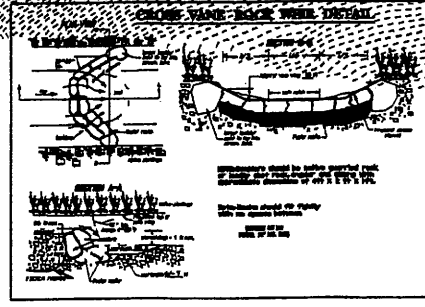
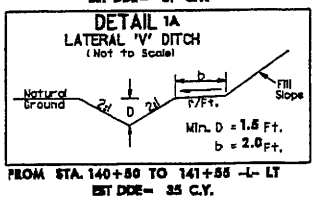
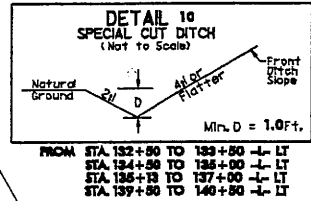
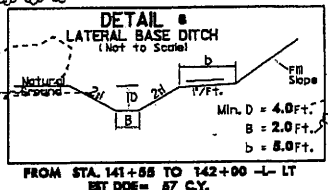
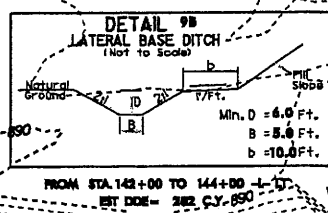
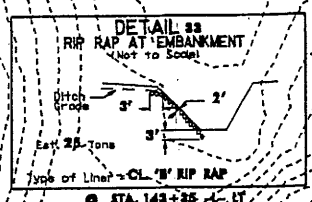

REVISIONS

27-APR-2005 15:18:43 13.dwg  
27-APR-2005 15:18:43 13.dwg  
27-APR-2005 15:18:43 13.dwg



PROJECT REFERENCE NO. R-3415	SHEET NO. 13
RWY SHEET NO.	
ROADWAY DESIGN ENGINEER	HYDRAULICS ENGINEER
<b>PRELIMINARY PLANS</b> DO NOT USE FOR CONSTRUCTION	

Sheet 16 of 28

**NOTE**

FOR -L- PROFILE SEE SHEETS 29,30  
FOR -D5- PROFILE SEE SHEET 38  
ALL DRIVEWAY RADII ARE 15' UNLESS NOTED

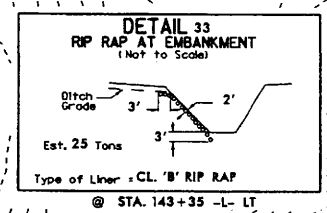

MATCH LINE SHEET 12

MATCH LINE SHEET 14

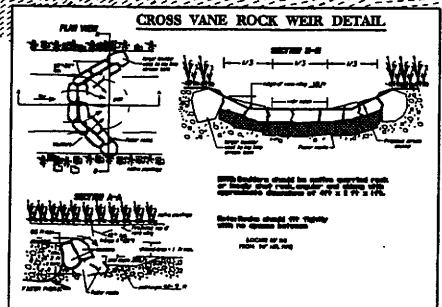
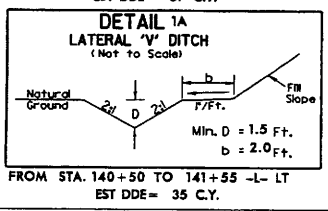
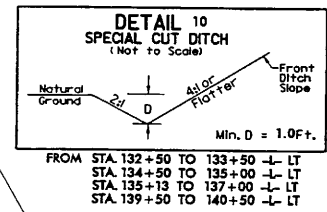
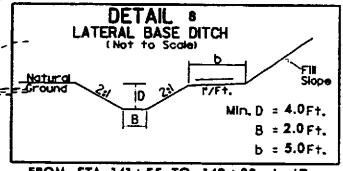
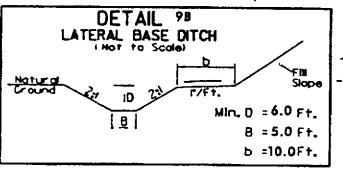
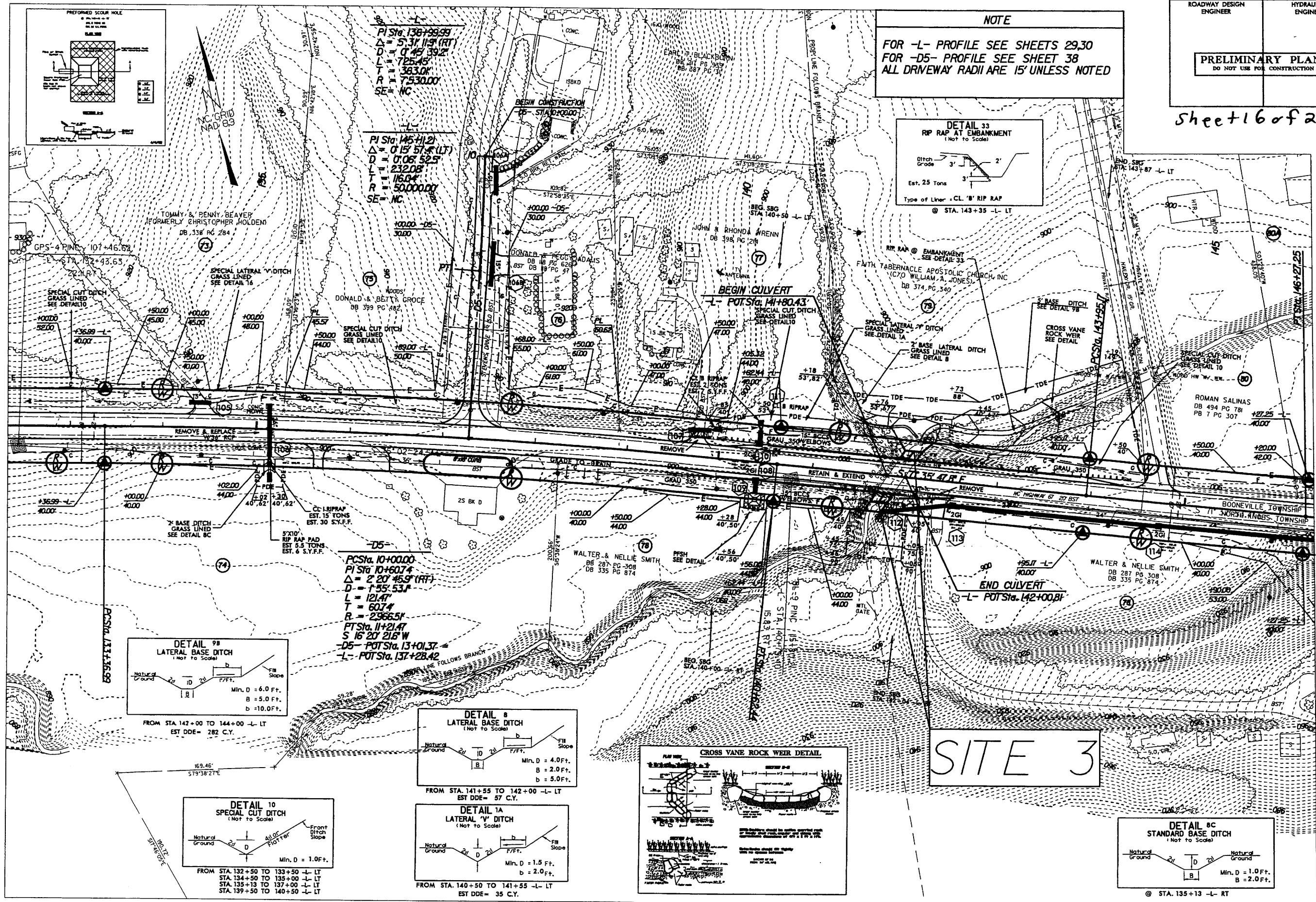

SITE 3

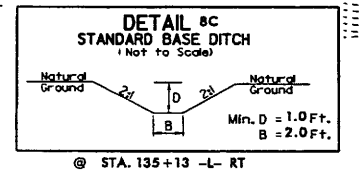

REVISIONS

03-JAN-2005 4:23 PM V:\3415\3415.dwg





PROJECT REFERENCE NO. R-3415	SHEET NO. 14
RW SHEET NO.	
ROADWAY DESIGN ENGINEER	HYDRAULICS ENGINEER
<b>PRELIMINARY PLANS</b> DO NOT USE FOR CONSTRUCTION	

Sheet 18 of 28

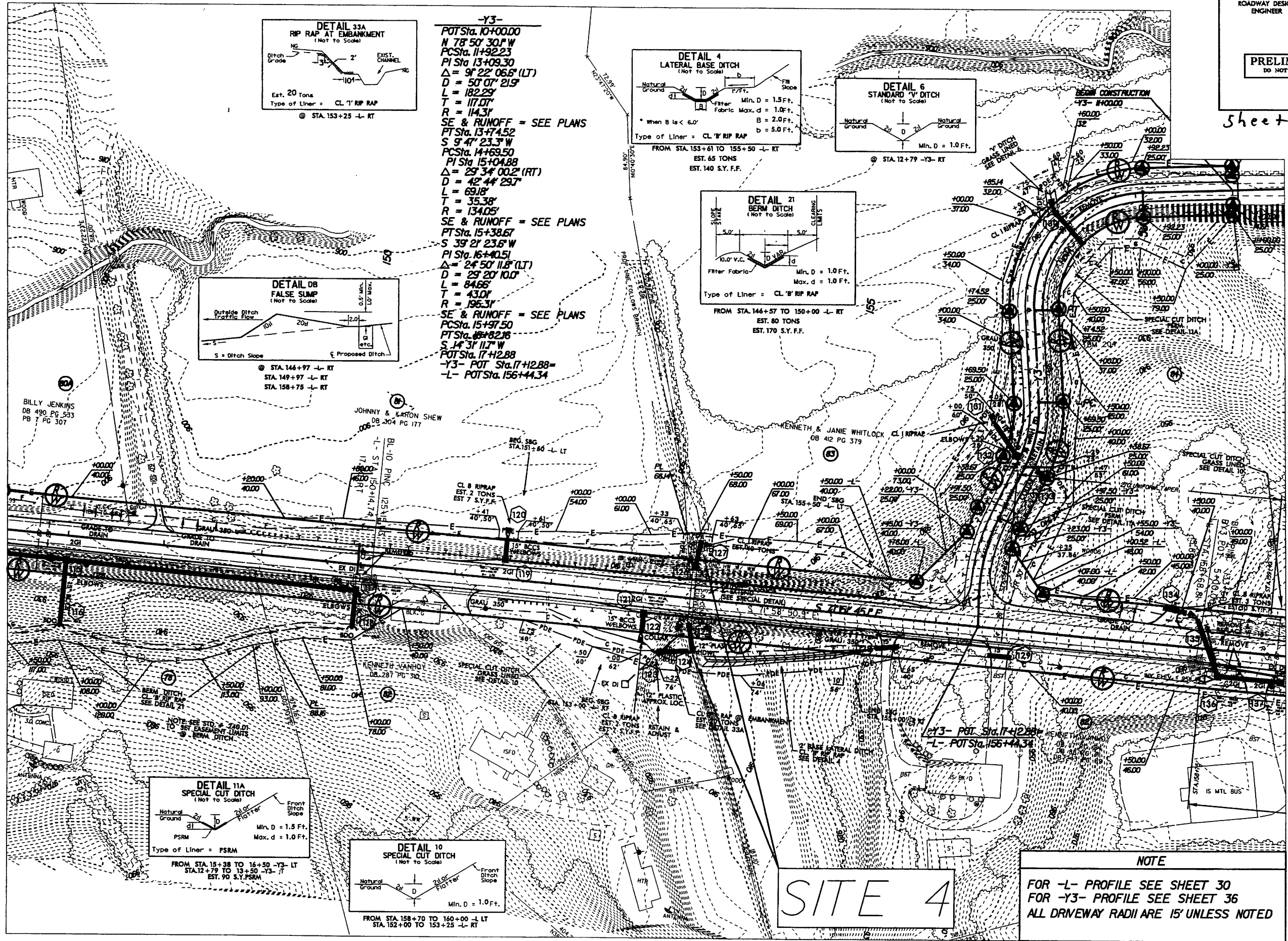

**-Y3-**  
 POT Sta. 10+00.00  
 N 78° 50' 30" W  
 PC Sta. 11+92.23  
 PI Sta. 13+09.30  
 $\Delta = 9' 22' 06.6"$  (LT)  
 $D = 50' 07' 21.9"$   
 $L = 182.29'$   
 $T = 117.07'$   
 $R = 114.31'$   
 SE & RUNOFF = SEE PLANS  
 PT Sta. 13+74.52  
 S 9° 47' 23.3" W  
 PC Sta. 14+69.50  
 PI Sta. 15+04.88  
 $\Delta = 29' 34' 00.2"$  (RT)  
 $D = 42' 44' 29.7"$   
 $L = 69.18'$   
 $T = 35.38'$   
 $R = 134.05'$   
 SE & RUNOFF = SEE PLANS  
 PT Sta. 15+38.67  
 S 39° 21' 23.6" W  
 PI Sta. 16+40.51  
 $\Delta = 24' 50' 11.8"$  (LT)  
 $D = 29' 20' 10.0"$   
 $L = 84.66'$   
 $T = 43.01'$   
 $R = 196.31'$   
 SE & RUNOFF = SEE PLANS  
 PC Sta. 15+97.50  
 PT Sta. 16+82.16  
 S 14° 31' 11.7" W  
 POT Sta. 17+42.88  
 -Y3- POT Sta. 17+42.88  
 -L- POT Sta. 156+44.34

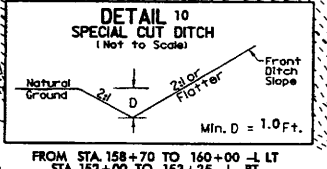
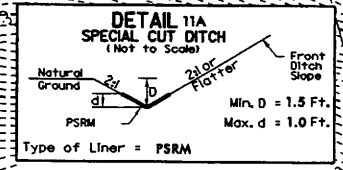
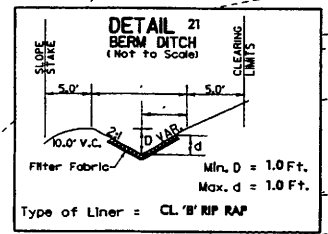
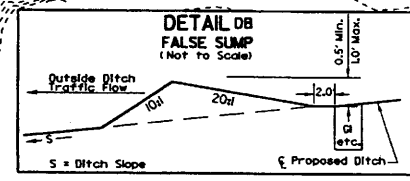
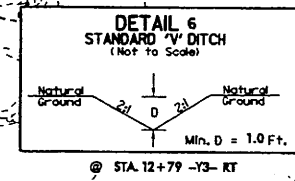
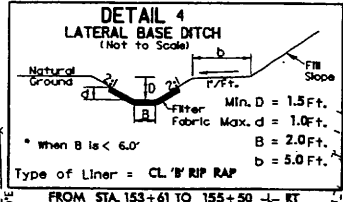
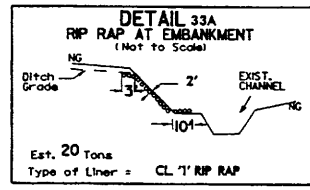

**SITE 4**

**NOTE**  
 FOR -L- PROFILE SEE SHEET 30  
 FOR -Y3- PROFILE SEE SHEET 36  
 ALL DRIVEWAY RADII ARE 15' UNLESS NOTED

REVISIONS

MATCH LINE SHEET 13

MATCH LINE SHEET 15

2/24/04 ADDED RAW MON TO -Y3- ON PT/S/PCS

09-DEC-2004 16:17  
 C:\p\d\p\p-3415\3415ps14\_permt.site\*4.dgn

Sheet 19 of 28  
rev. 4/27/05

**NOTE**  
FOR -L- PROFILE SEE SHEET 30  
ALL DRIVEWAY RADII ARE 15' UNLESS NOTED

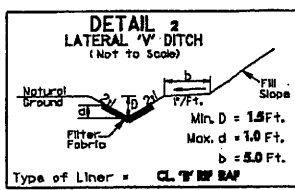
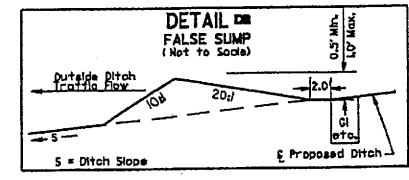
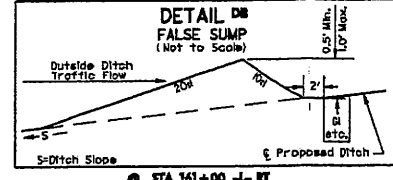
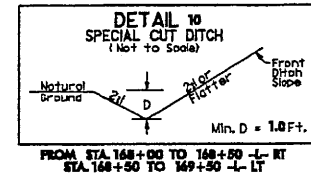
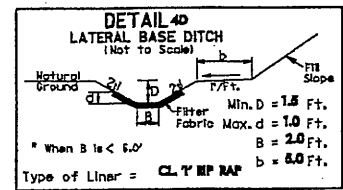
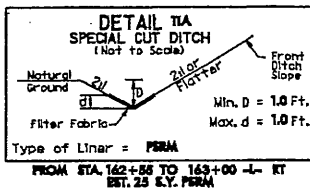

MATCH LINE SHEET 14

MATCH LINE SHEET 16

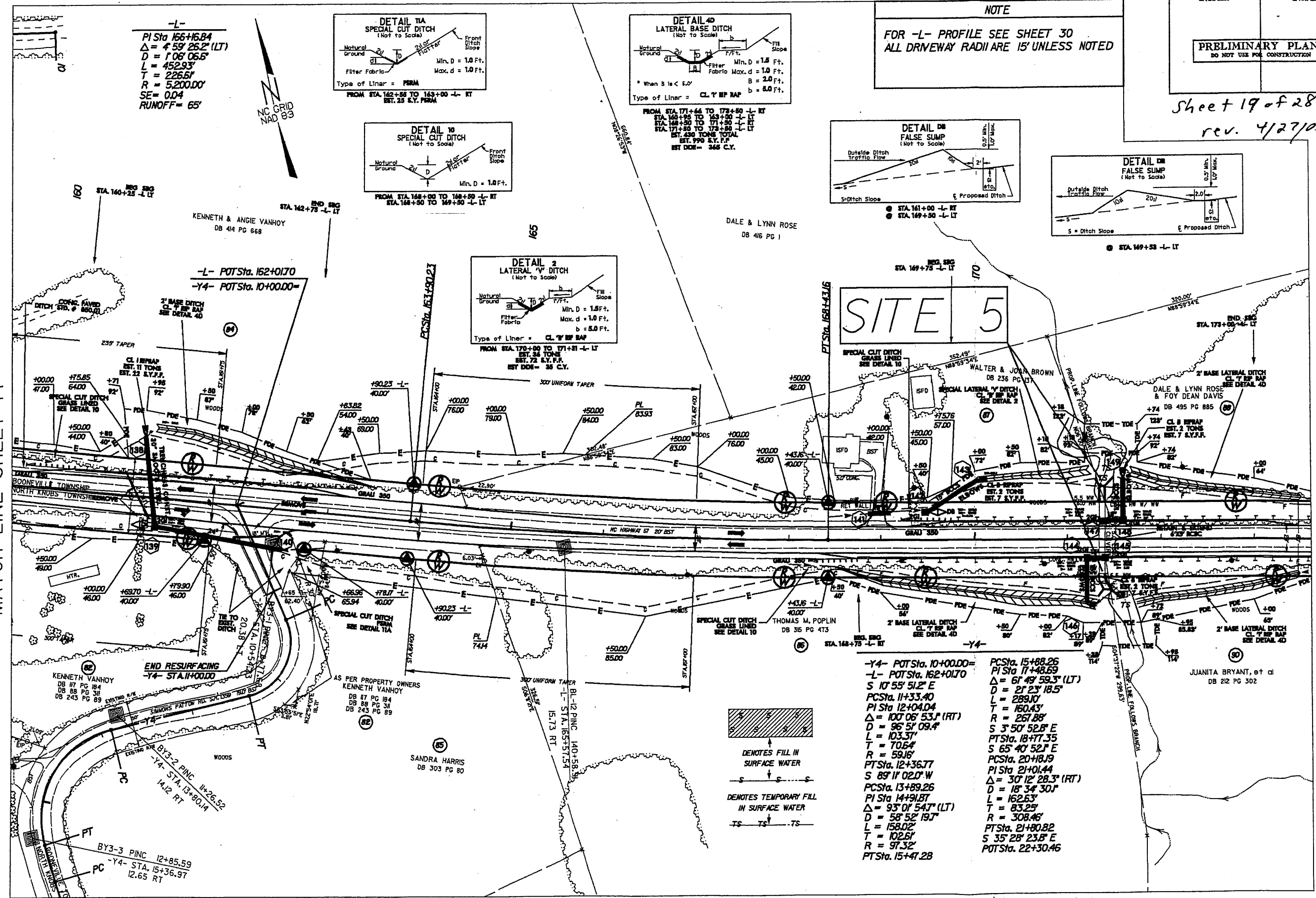

-Y4- POT Sta. 10+00.00=  
-L- POT Sta. 162+01.70  
S 10° 55' 51.2" E  
PC Sta. 11+33.40  
PI Sta. 12+04.04  
Δ = 107° 08' 53.1" (RT)  
D = 96° 51' 09.4"  
L = 103.37'  
T = 70.64'  
R = 59.16'  
PT Sta. 12+36.77  
S 89° 11' 02.0" W  
PC Sta. 13+89.26  
PI Sta. 14+91.87  
Δ = 93° 01' 54.7" (LT)  
D = 58° 52' 19.7"  
L = 158.02'  
T = 102.61'  
R = 97.32'  
PT Sta. 15+47.28

PC Sta. 15+88.26  
PI Sta. 17+48.69  
Δ = 61° 49' 59.3" (LT)  
D = 21° 23' 18.5"  
L = 289.10'  
T = 160.43'  
R = 267.88'  
S 3° 50' 52.8" E  
PT Sta. 18+77.35  
S 65° 40' 52.1" E  
PC Sta. 20+88.19  
PI Sta. 21+01.44  
Δ = 30° 12' 28.3" (RT)  
D = 18° 34' 30.1"  
L = 162.63'  
T = 83.25'  
R = 308.46'  
PT Sta. 21+80.82  
S 35° 28' 23.8" E  
POT Sta. 22+30.46

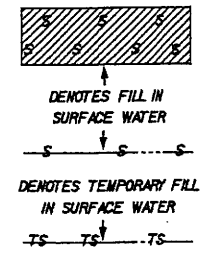

8/17/99  
REVISIONS  
27 APR 2005 [initials]  
21 NOV 2004 [initials]  
15 JUL 2004 [initials]

Sheet 19 of 28

**NOTE**  
FOR -L- PROFILE SEE SHEET 30  
ALL DRIVEWAY RADII ARE 15' UNLESS NOTED

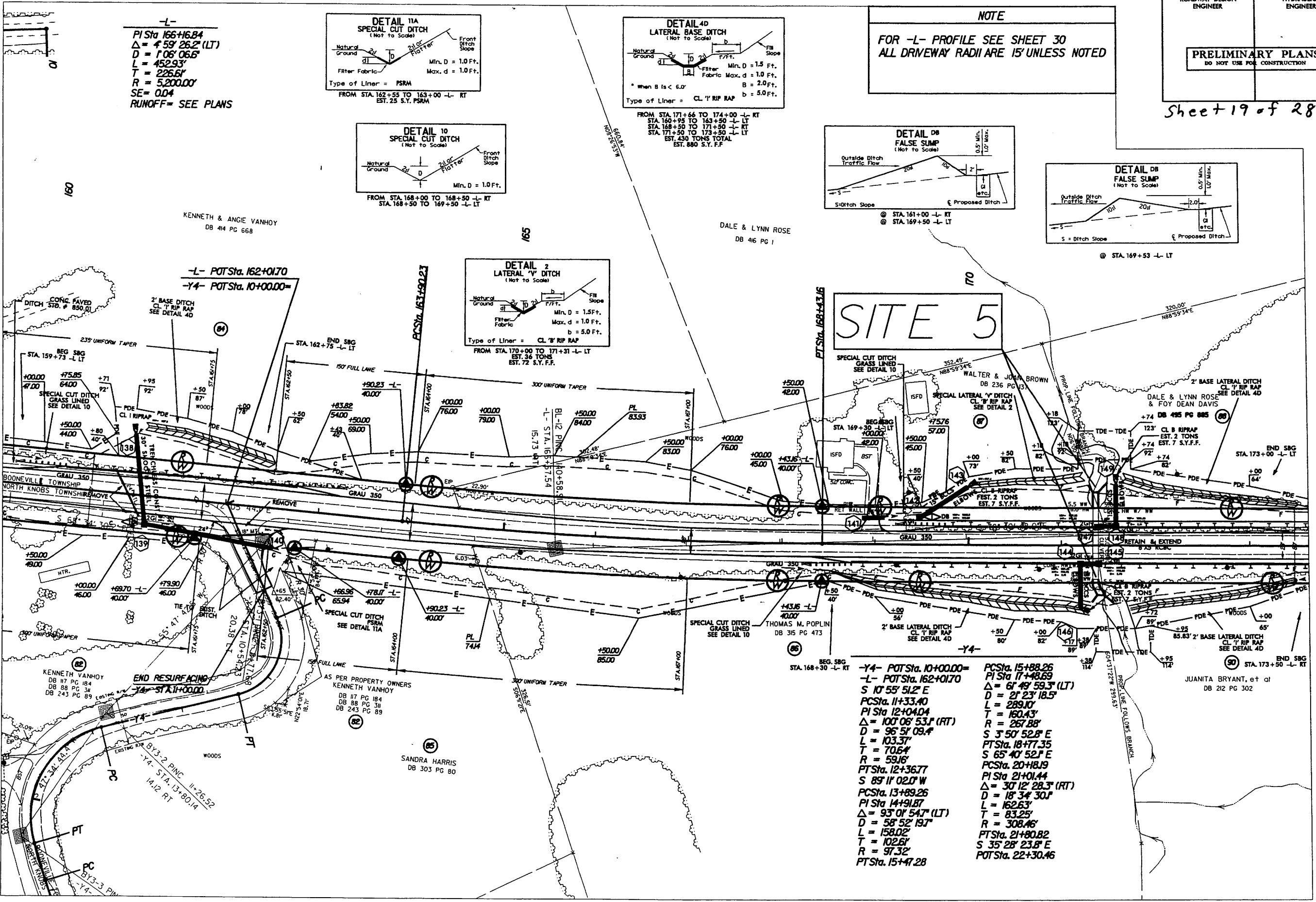

-L-  
PI Sta 166+16.84  
 $\Delta = 4' 59'' 26.2''$  (LT)  
D = 1'08' 06.6"  
L = 452.93'  
T = 226.61'  
R = 5200.00'  
SE = 0.04  
RUNOFF = SEE PLANS

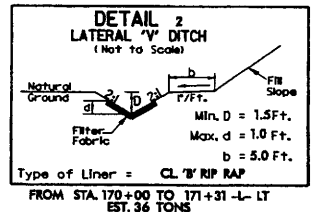
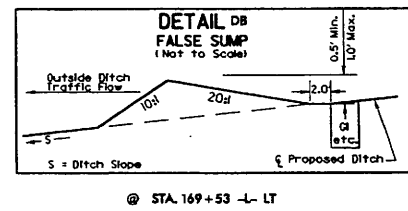
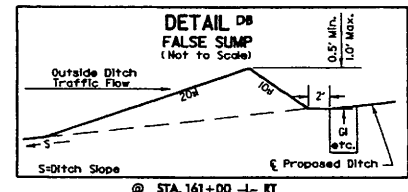
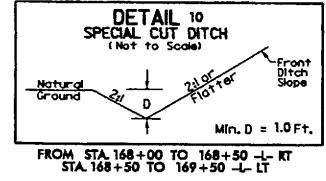
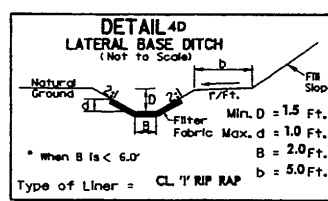
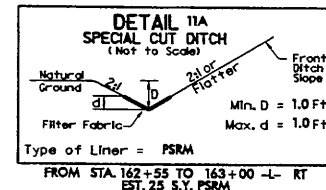

**SITE 5**

MATCH LINE SHEET 14

MATCH LINE SHEET 16

END RESURFACING  
-Y4- STA. 10+00.00 =

AS PER PROPERTY OWNERS  
KENNETH VANHOY  
DB 17 PG 184  
DB 88 PG 311  
DB 243 PG 89

SANDRA HARRIS  
DB 303 PG 80

JUANITA BRYANT, et al  
DB 212 PG 302

END S.B.G.  
STA. 173+50 -L- LT

END S.B.G.  
STA. 168+30 -L- RT

-Y4- POT Sta. 10+00.00 =

-L- POT Sta. 162+01.70

PC Sta. 11+33.40  
PI Sta. 12+04.04  
 $\Delta = 100' 06'' 53.1''$  (RT)  
D = 96' 51'' 09.4"  
L = 103.37'  
T = 70.64'  
R = 59.16'  
PT Sta. 12+36.77  
S 89° 11' 02.0" W  
PC Sta. 13+89.26  
PI Sta. 14+91.87  
 $\Delta = 93' 01'' 54.7''$  (LT)  
D = 58' 52'' 19.7"  
L = 158.02'  
T = 102.61'  
R = 97.32'  
PT Sta. 15+47.28

PC Sta. 15+88.26  
PI Sta. 17+48.69  
 $\Delta = 61' 49'' 59.3''$  (LT)  
D = 21' 23'' 18.5"  
L = 289.10'  
T = 160.43'  
R = 267.88'  
S 3° 50' 52.8" E  
PT Sta. 18+77.35  
S 65° 40' 52.1" E  
PC Sta. 20+18.19  
PI Sta. 21+01.44  
 $\Delta = 30' 12'' 28.3''$  (RT)  
D = 18' 34'' 30.1"  
L = 162.63'  
T = 83.25'  
R = 308.46'  
PT Sta. 21+80.82  
S 35° 28' 23.8" E  
POT Sta. 22+30.46



Sheet 20 of 28  
rev. 4/27/05

**NOTE**  
FOR -L- PROFILE SEE SHEET 30  
ALL DRIVEWAY RADII ARE 15' UNLESS NOTED

**-L-**  
PI Sta 166+16.84  
 $\Delta = 4^{\circ} 59' 26.2" (LT)$   
D = 1'08" 06.5"  
L = 452.93'  
T = 226.61'  
R = 5,200.00'  
SE = 0.04  
RUNOFF = 65'

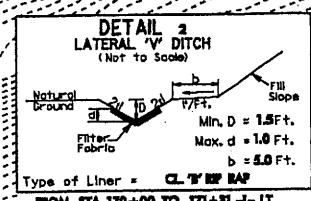
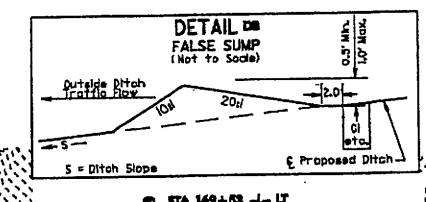
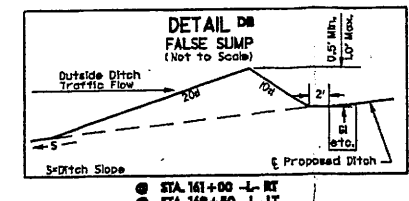
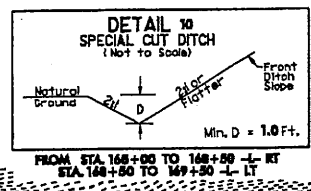
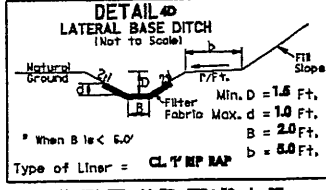
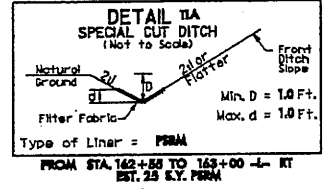

**SITE 5**

MATCH LINE SHEET 14

MATCH LINE SHEET 16

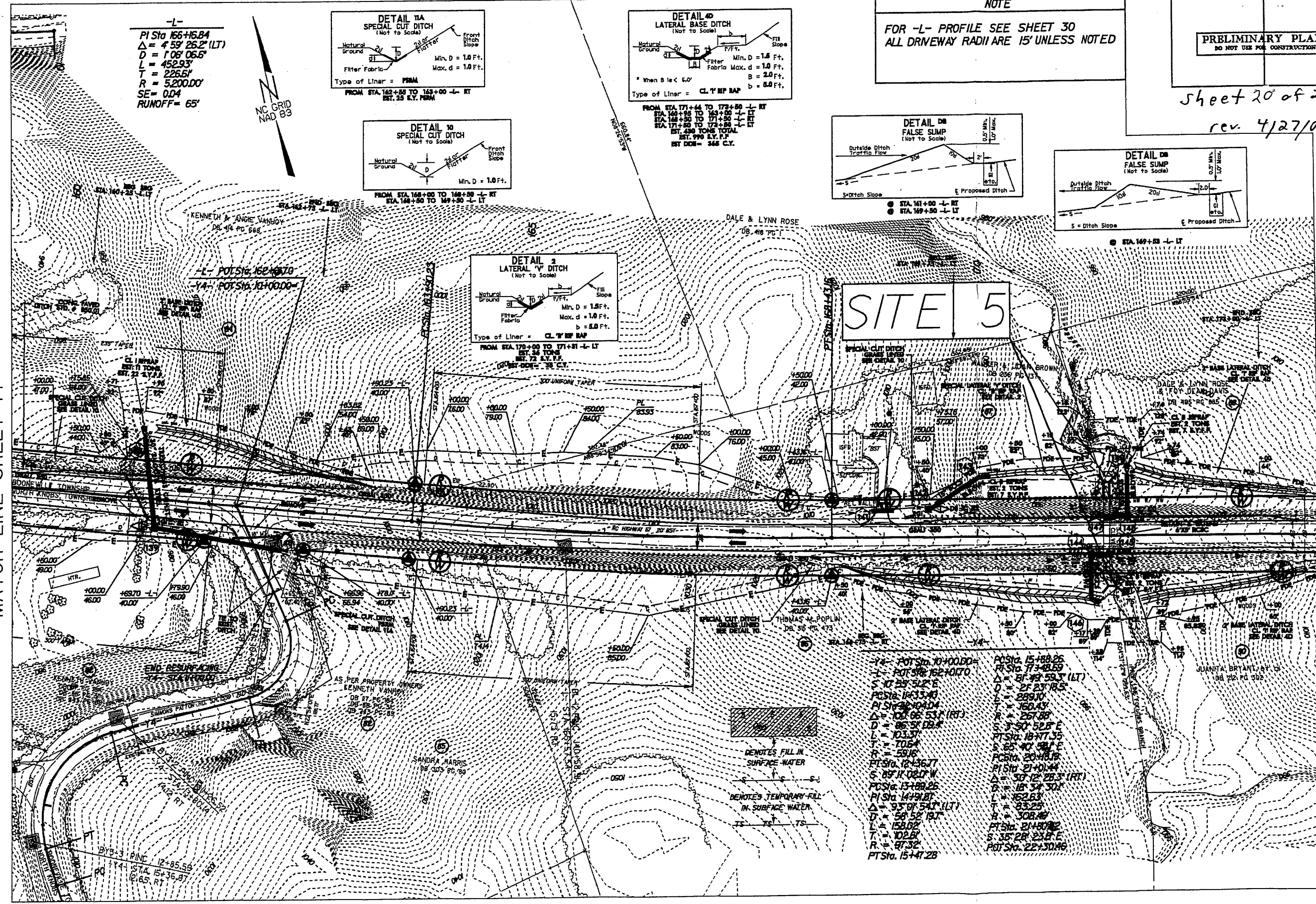

Y4 - POT Sta. 10+00.00  
 -L- POT Sta. 162+10.70  
 S RT 85 51.2' E  
 PC Sta. 164.33 40  
 PI Sta. 164.04 04  
 $\Delta = 100^{\circ} 06' 53.7" (RT)$   
 D = 86.51 02.8'  
 L = 103.37'  
 T = 105.4'  
 R = 5916'  
 PT Sta. 12+436.71  
 S RT 11 02.0' W  
 PC Sta. 13+189.26  
 PI Sta. 14+91.87  
 $\Delta = 93^{\circ} 01' 54.7" (LT)$   
 D = 50.52 19.7'  
 L = 158.02'  
 T = 102.61'  
 R = 97.32'  
 PT Sta. 15+147.28  
  
 PC Sta. 15+188.26  
 PI Sta. 17+48.69  
 $\Delta = 51^{\circ} 49' 59.3" (LT)$   
 D = 21.23 13.5'  
 L = 289.10'  
 T = 160.43'  
 R = 257.89'  
 S 3 50 52.8' E  
 PT Sta. 18+171.35  
 S 65 40 58.1' E  
 PC Sta. 20+18.18  
 PI Sta. 21+10.44  
 $\Delta = 50^{\circ} 12' 28.3" (RT)$   
 D = 18.31 30.1'  
 L = 162.63'  
 T = 83.25'  
 R = 308.46'  
 PT Sta. 21+180.82  
 S 35 28 23.8' E  
 POT Sta. 22+301.96

21 APR 2005 15:48:41 15:48:41 15:48:41 15:48:41 15:48:41  
 21 APR 2005 15:48:41 15:48:41 15:48:41 15:48:41 15:48:41  
 21 APR 2005 15:48:41 15:48:41 15:48:41 15:48:41 15:48:41

Sheet 20 of 28

**NOTE**  
FOR -L- PROFILE SEE SHEET 30  
ALL DRIVEWAY RADII ARE 15' UNLESS NOTED

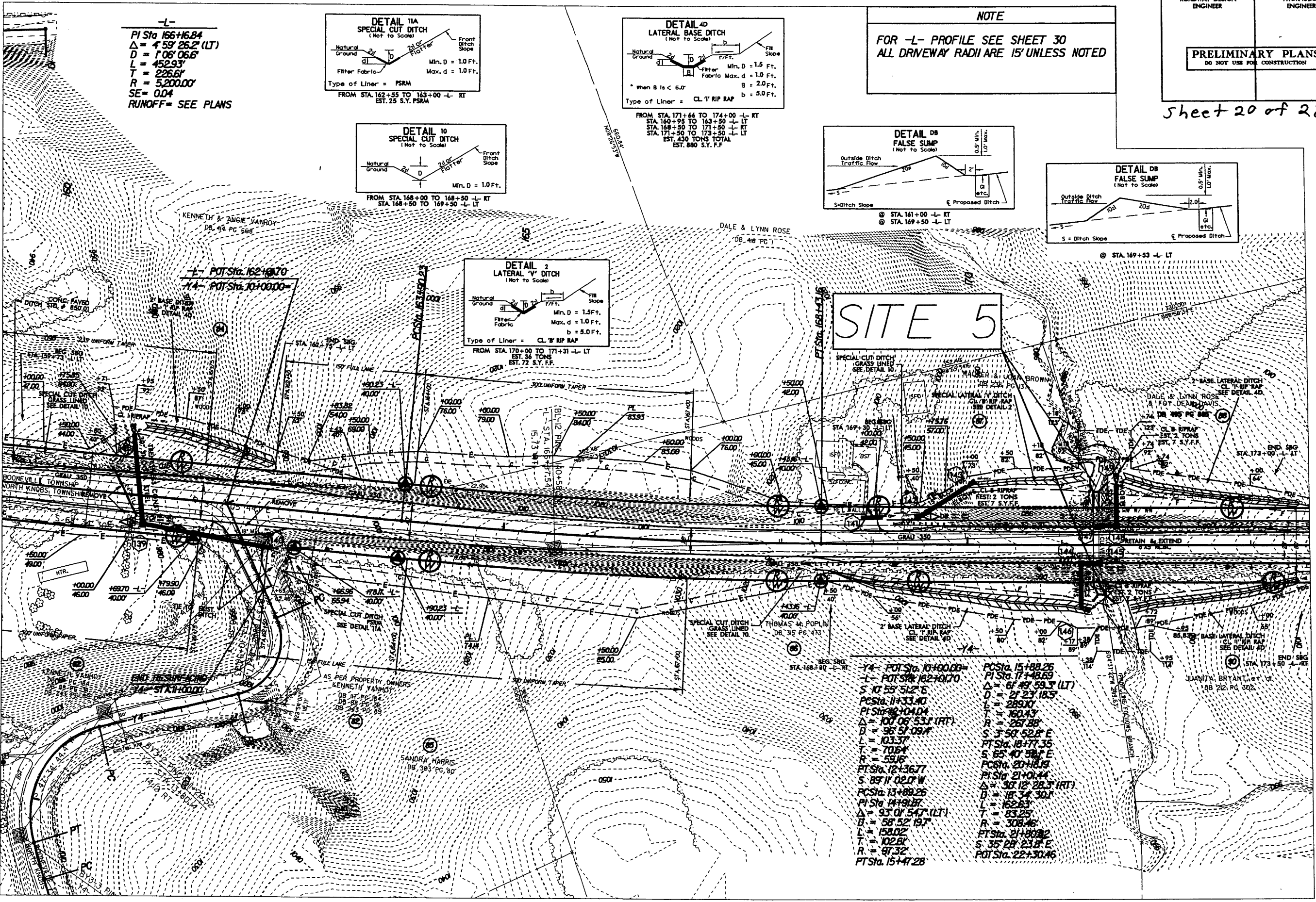

**-L-**  
PI Sta 166+16.84  
 $\Delta = 4' 59'' 26.2''$  (LT)  
 $D = 1' 06'' 06.6''$   
 $L = 452.93'$   
 $T = 226.61'$   
 $R = 5200.00'$   
 $SE = 0.04$   
RUNOFF = SEE PLANS

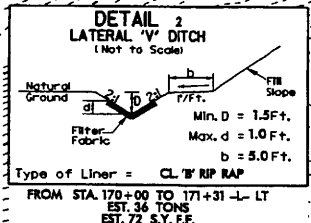
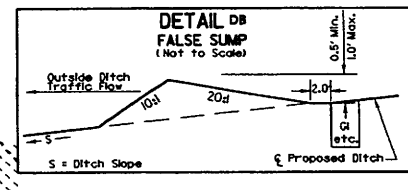
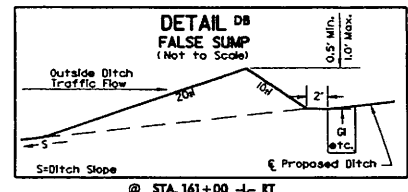
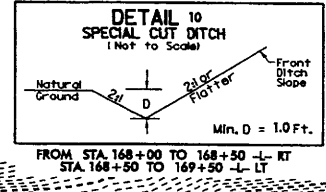
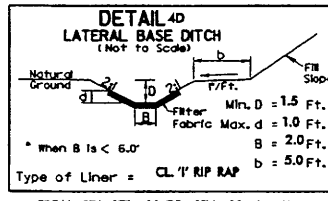
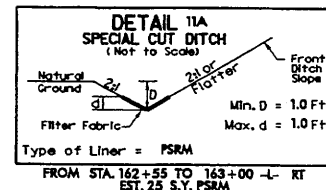

**SITE 5**

Y4- POT Sta. 10+00.00	PC Sta. 15+88.26
-L- POT Sta. 162+01.70	PI Sta. 17+48.69
S 10° 55' 51.2" E	$\Delta = 61' 49'' 59.3''$ (LT)
PC Sta. 11+33.40	$D = 21' 23'' 18.3''$
PI Sta. 12+04.04	$L = 289.10'$
$\Delta = 100' 08'' 53.1''$ (RT)	$T = 160.43'$
$D = 96' 51'' 09.7''$	$R = 267.88'$
$L = 103.37'$	$S 3' 50'' 52.8''$ E
$T = 70.64'$	PT Sta. 18+77.35
$R = 59.16'$	$S 85' 40'' 58.1''$ E
PT Sta. 12+36.77	PC Sta. 20+18.19
$S 85' 11'' 02.0''$ W	PI Sta. 21+01.44
PC Sta. 13+89.26	$\Delta = 30' 12'' 28.3''$ (RT)
PI Sta. 14+19.87	$D = 18' 34'' 30.1''$
$\Delta = 93' 01'' 54.7''$ (LT)	$L = 162.63'$
$B = 58' 52'' 19.7''$	$T = 83.25'$
$L = 158.02'$	$R = 308.46'$
$T = 102.61'$	PT Sta. 21+10.82
$R = 97.32'$	$S 35' 28'' 23.8''$ E
PT Sta. 15+47.28	POT Sta. 22+30.46

8/17/99

REVISIONS

MATCH LINE SHEET 14

MATCH LINE SHEET 16

Sheet 21 of 28

**NOTE**  
FOR -L- PROFILE SEE SHEET 32  
ALL DRIVEWAY RADII ARE 15' UNLESS NOTED

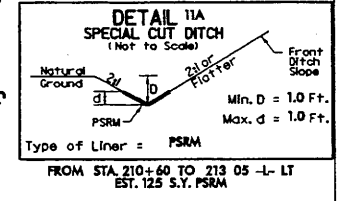
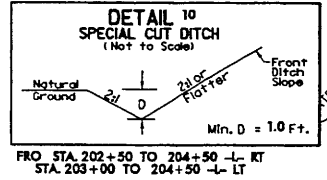
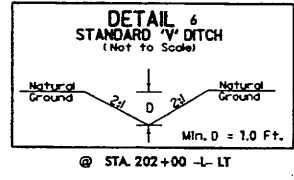

LINDA S. JOHNSON,  
ORRIN D. SHAW, JR.,  
STEVEN F. BRYANT,  
DEBRA M. BRYANT,  
JAY S. BRYANT,  
FRANK L. SMITH,  
DANIEL B. SMITH,  
HUGH W. BRYANT,  
DOROTHY B. CHILTON,  
SUSAN L. BRYANT,  
AND LISA G. BRYANT  
DB 385 PG 702

**-Y5-**  
POT Sta. 10+00.00  
S 39° 52' 40.2" W  
PCSta. 11+90.00  
PI Sta. 13+92.89  
Δ = 44° 05' 44.5" (RT)  
D = 11' 26' 12.6"  
L = 385.56'  
T = 202.89'  
R = 500.98'  
SE=  
PTSta. 15+75.56  
S 83° 58' 24.8" W  
PCSta. 18+21.80  
PI Sta. 19+06.14  
Δ = 37° 35' 09.8" (LT)  
D = 23° 07' 01.1"  
L = 162.59'  
T = 84.34'  
R = 247.85'  
SE=  
PTSta. 19+84.39  
S 46° 23' 14.9" W

**-Y6-**  
POT Sta. 10+00.00=  
-L- POT Sta. 201+43.13  
S 34° 34' 18.6" W  
PCSta. 11+49.45  
PI Sta. 13+68.25  
Δ = 2° 10' 19.9" (LT)  
D = 0° 29' 47.2"  
L = 437.55'  
T = 218.80'  
R = 11541.23'  
SE=  
PTSta. 15+87.00  
S 32° 23' 58.7" W  
POT Sta. 16+49.41

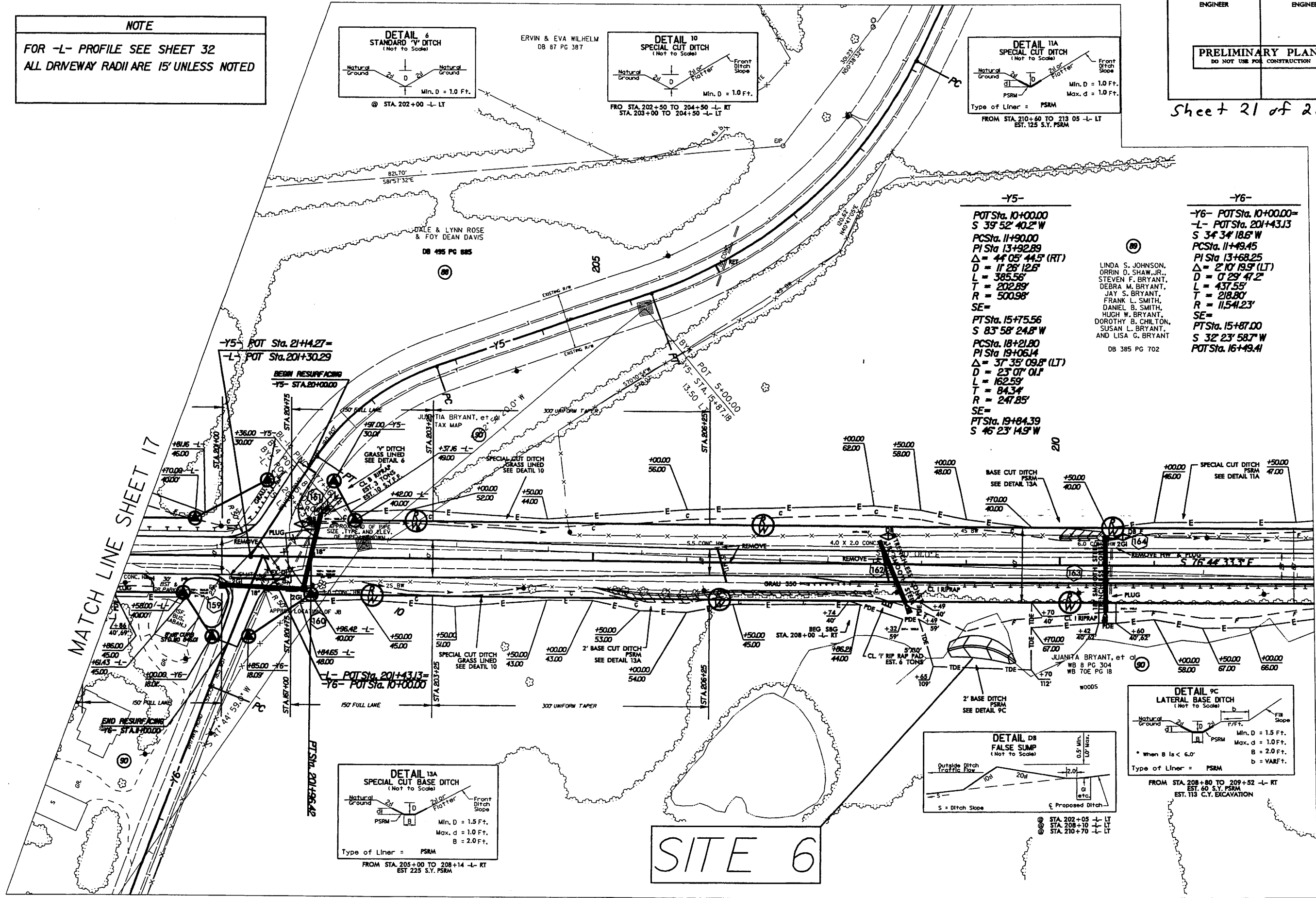

**SITE 6**

MATCH LINE SHEET 17

MATCH LINE SHEET 19

REVISIONS

8/17/95

08-DEC-2004 15:44  
C:\p\d\1-3415\18-permit.ssite#6.dgn



Sheet 22 of 28

**NOTE**  
FOR -L- PROFILE SEE SHEET 32  
ALL DRIVEWAY RADII ARE 15' UNLESS NOTED

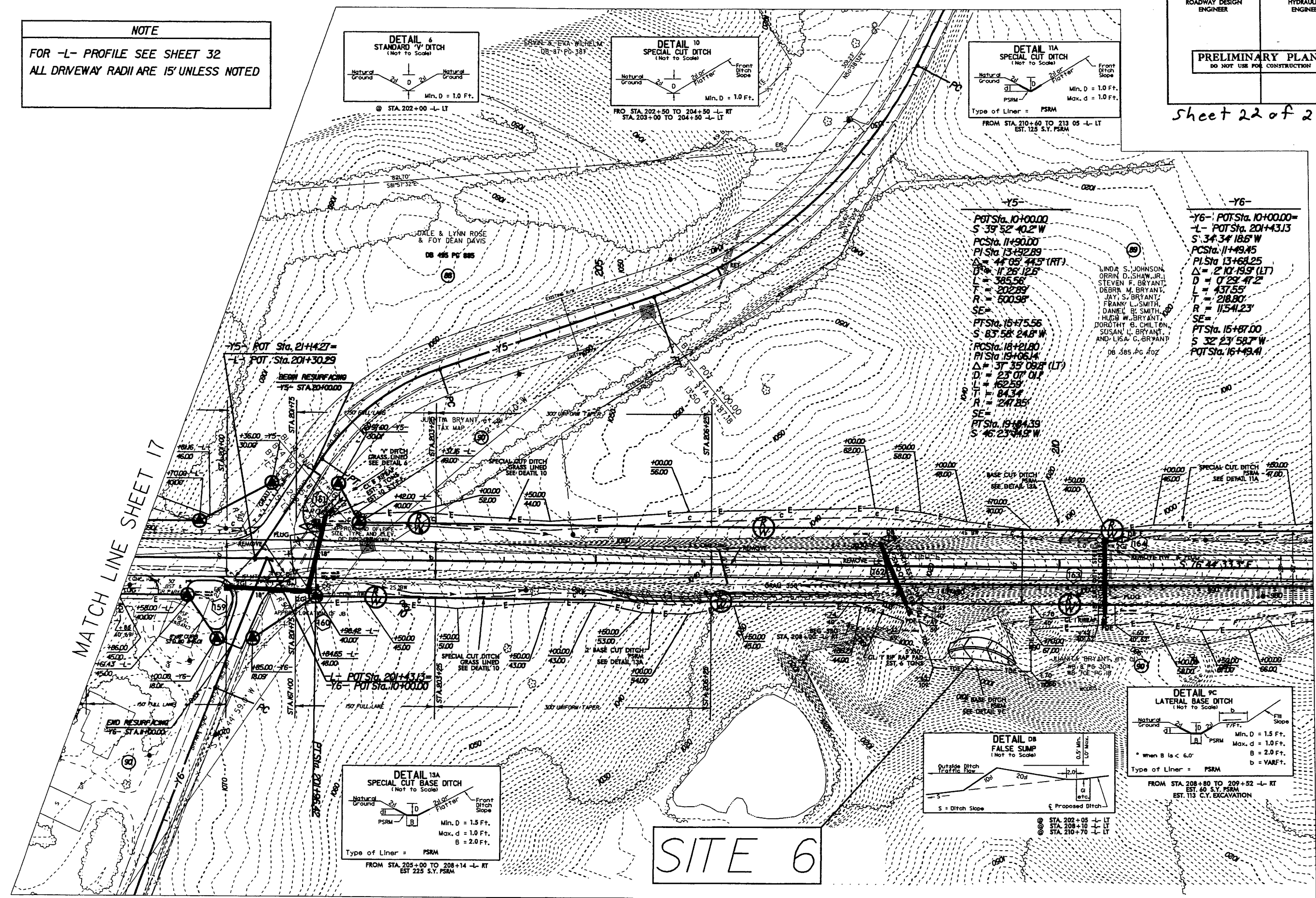
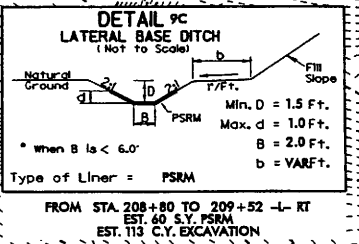
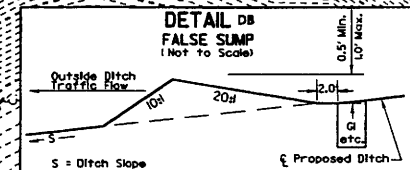
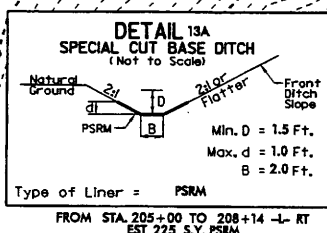
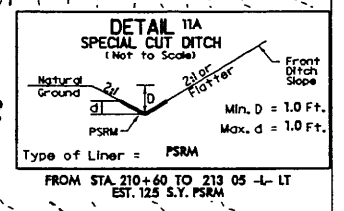
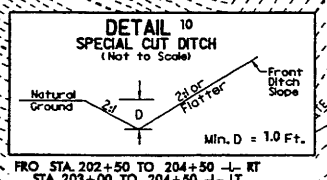
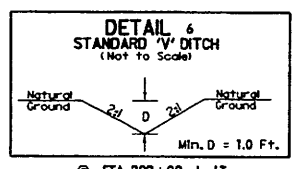

**SITE 6**

MATCH LINE SHEET 17

MATCH LINE SHEET 19

8/17/99

REVISIONS

03-DEC-2004 15:43:15 R-3415ps18\_permit.sst#6.dgn

PROJECT REFERENCE NO. R-3415	SHEET NO. 19
RW SHEET NO.	
ROADWAY DESIGN ENGINEER	HYDRAULICS ENGINEER
<b>PRELIMINARY PLANS</b> DO NOT USE FOR CONSTRUCTION	

Sheet 23 of 28

**NOTE**  
FOR -L- PROFILE SEE SHEET 32  
ALL DRIVEWAY RADII ARE 15' UNLESS NOTED

-L-  
PI Sta 222+34.56  
 $\Delta = 0^{\circ} 06' 51.0" (LT)$   
 $D = 0^{\circ} 03' 26.3"$   
 $L = 199.24'$   
 $T = 99.62'$   
 $R = 100,000.00'$   
SE=

LINDA S. JOHNSON,  
ORRIN D. SHAW, JR.,  
STEVEN F. BRYANT,  
DEBRA M. BRYANT,  
JAY S. BRYANT,  
FRANK L. SMITH,  
DANIEL B. SMITH,  
HUGH W. BRYANT,  
DOROTHY B. CHILTON,  
SUSAN L. BRYANT,  
AND LISA G. BRYANT  
DB 385 PG 702

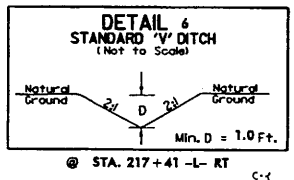
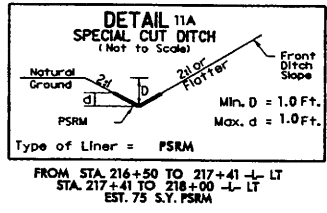

MATCH LINE SHEET 18

MATCH LINE SHEET 20

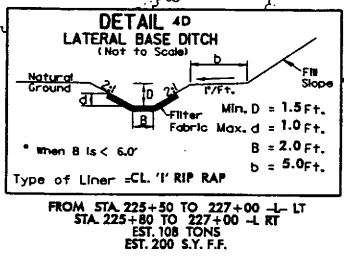
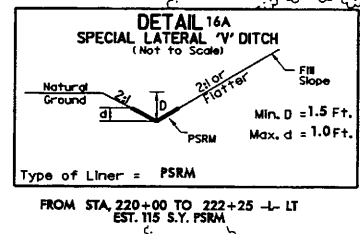
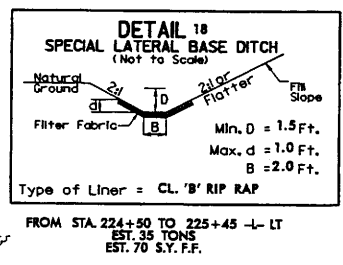
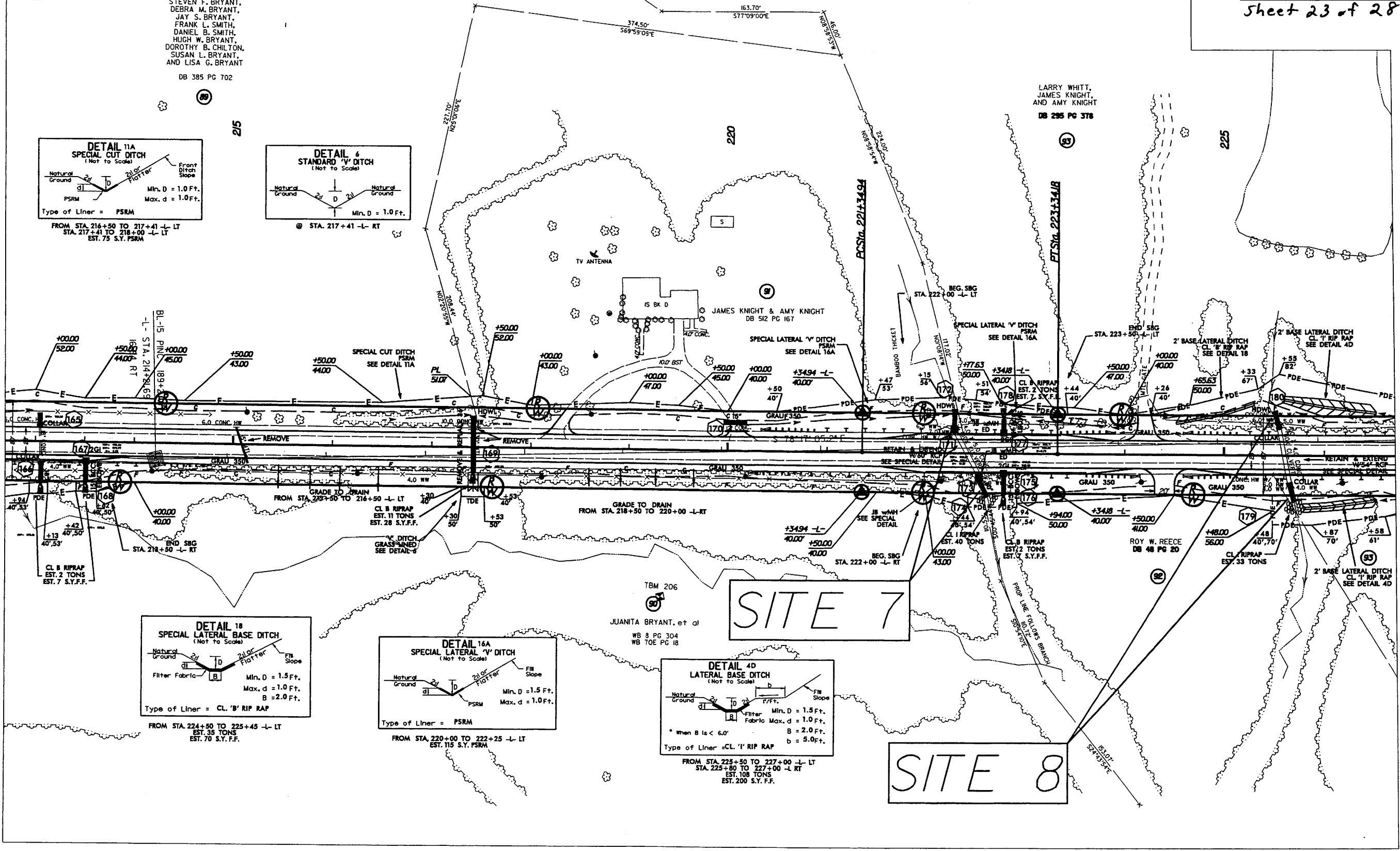

REVISIONS  
6/22/04 ADDED 20' GRAVEL DRIVEWAY AND MODIFIED GUARDRAIL AT -L- STA. 224+40 RT

09-DEC-2004 15:24  
C:\p\d\15-3415ps19\_permit.site\*7-8.dgn  
Lash

8/17/99



PROJECT REFERENCE NO.	SHEET NO.
R-3415	19
RW SHEET NO.	
ROADWAY DESIGN ENGINEER	HYDRAULICS ENGINEER
PRELIMINARY PLANS DO NOT USE FOR CONSTRUCTION	

Sheet 24 of 28

**NOTE**  
FOR -L- PROFILE SEE SHEET 32  
ALL DRIVEWAY RADII ARE 15' UNLESS NOTED

-L-  
PI Sta 222+34.56  
 $\Delta = 0' 06' 51.0" (LT)$   
 $D = 0' 03' 26.3"$   
 $L = 199.24'$   
 $T = 99.62'$   
 $R = 100,000.00'$   
SE=

LINDA S. JOHNSON,  
ORRIN D. SHAW, JR.,  
STEVEN F. BRYANT,  
DEBRA M. BRYANT,  
JAY S. BRYANT,  
FRANK L. SMITH,  
DANIEL B. SMITH,  
HUGH W. BRYANT,  
DOROTHY B. CHILTON,  
SUSAN L. BRYANT,  
AND LISA G. BRYANT  
DB 385 PG 702

LARRY WHITT,  
JAMES KNIGHT,  
AND AMY KNIGHT  
DB 296 PG 378

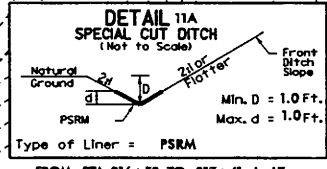

FROM STA 216+50 TO 217+41 -L- LT  
STA 217+41 TO 218+00 -L- LT  
EST. 75 S.Y. PSRM

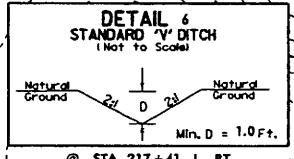

@ STA. 217+41 -L- RT

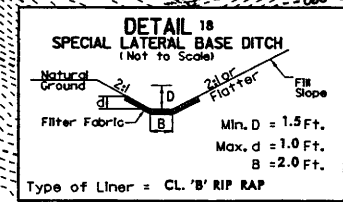

FROM STA 224+50 TO 225+45 -L- LT  
EST. 35 TONS  
EST. 70 S.Y. F.F.

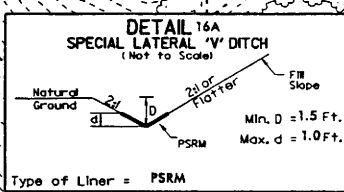

FROM STA 220+00 TO 222+25 -L- LT  
EST. 115 S.Y. PSRM

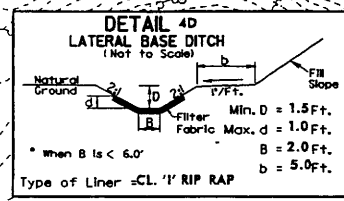

FROM STA 225+50 TO 227+00 -L- LT  
STA 225+80 TO 227+00 -L- RT  
EST. 108 TONS  
EST. 200 S.Y. F.F.

SITE 7

SITE 8

MATCH LINE SHEET 18

MATCH LINE SHEET 20

REVISIONS  
6/22/04 ADDED 20' GRAVEL DRIVEWAY AND MODIFIED GUARDRAIL AT -L- STA. 224+40 RT

09-DEC-2004 15:25  
C:\p\d\11-3415\11-3415ps19.permit.site\*7-8.dgn  
Castro

8/17/99

PROJECT REFERENCE NO. R-3415	SHEET NO. 20
RW SHEET NO.	
ROADWAY DESIGN ENGINEER	HYDRAULICS ENGINEER
<b>PRELIMINARY PLANS</b> DO NOT USE FOR CONSTRUCTION	

Sheet 25 of 28

**NOTE**  
FOR -L- PROFILE SEE SHEET 33  
ALL DRIVEWAY RADII ARE 15' UNLESS NOTED

-L-  
PI Sta 234+95.73  
 $\Delta = 4' 08" 21.2" (LT)$   
 $D = 0' 30" 46.1"$   
 $L = 807.16'$   
 $T = 403.76'$   
 $R = 11,722.88'$   
SE =

MATCH LINE SHEET 19

MATCH LINE SHEET 21

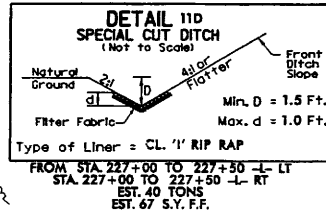
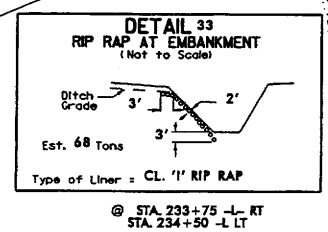
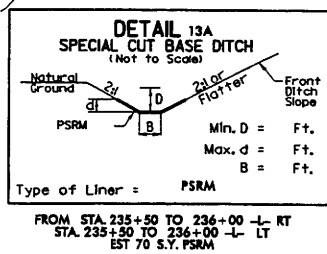
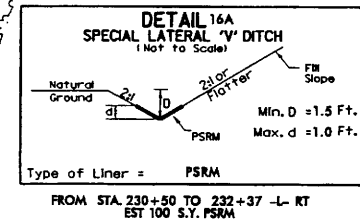
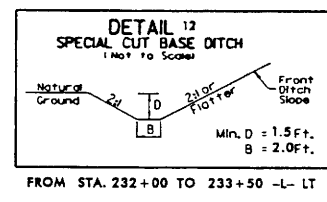
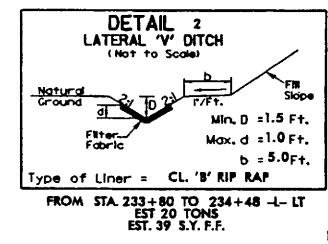
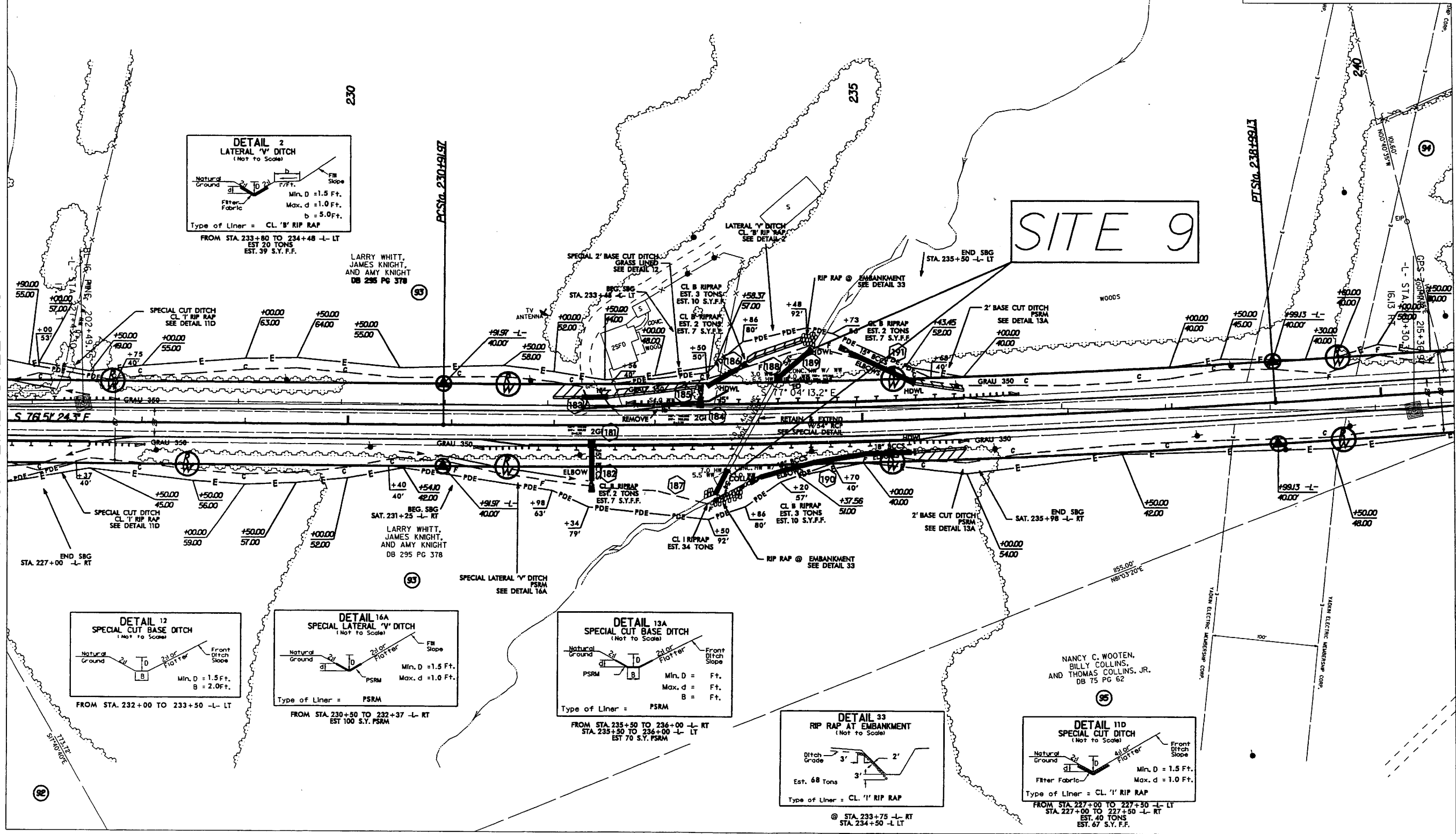

REVISIONS

09-DEC-2004 15:25  
C:\p\p\1-3415\1-3415ps20.permit.site\*9.dgn

PROJECT REFERENCE NO. R-3415	SHEET NO. 20
RW SHEET NO.	
ROADWAY DESIGN ENGINEER	HYDRAULICS ENGINEER
<b>PRELIMINARY PLANS</b> DO NOT USE FOR CONSTRUCTION	

**NOTE**  
FOR -L- PROFILE SEE SHEET 33  
ALL DRIVEWAY RADII ARE 15' UNLESS NOTED

-L-  
PI Sta 234+95.73  
 $\Delta = 4'08''21.2''$  (LT)  
 $D = 0'30''46.1''$   
 $L = 807.16'$   
 $T = 403.76'$   
 $R = 11,728.88'$   
SE =

Sheet 26 of 28

MATCH LINE SHEET 19

MATCH LINE SHEET 21

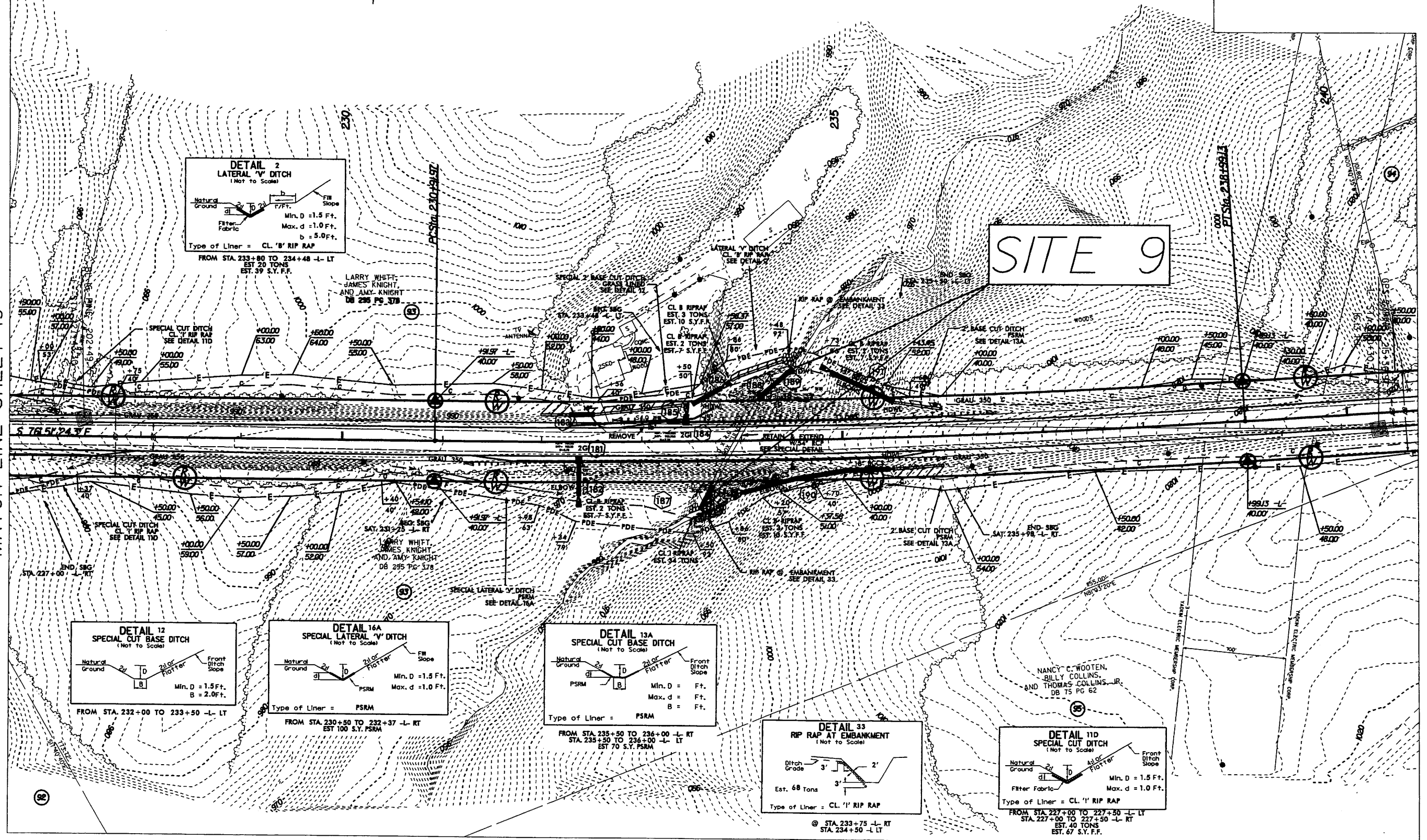

REVISIONS

08-DEC-2004 15:26  
C:\rd\p\3415\3415ps20\_permit.site#9.dgn

Sheet 27 of 28

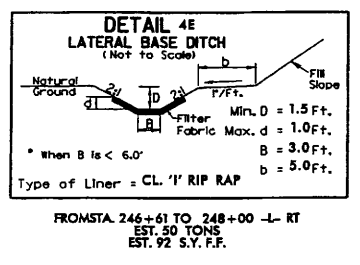
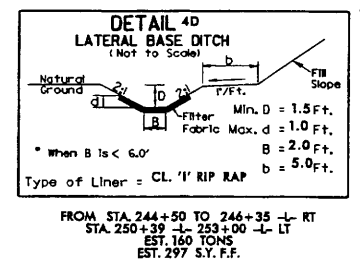
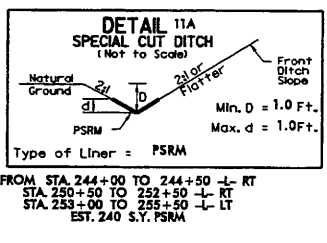
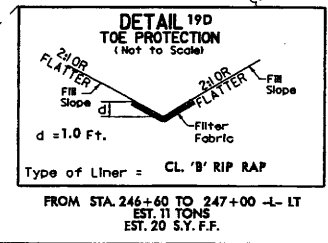
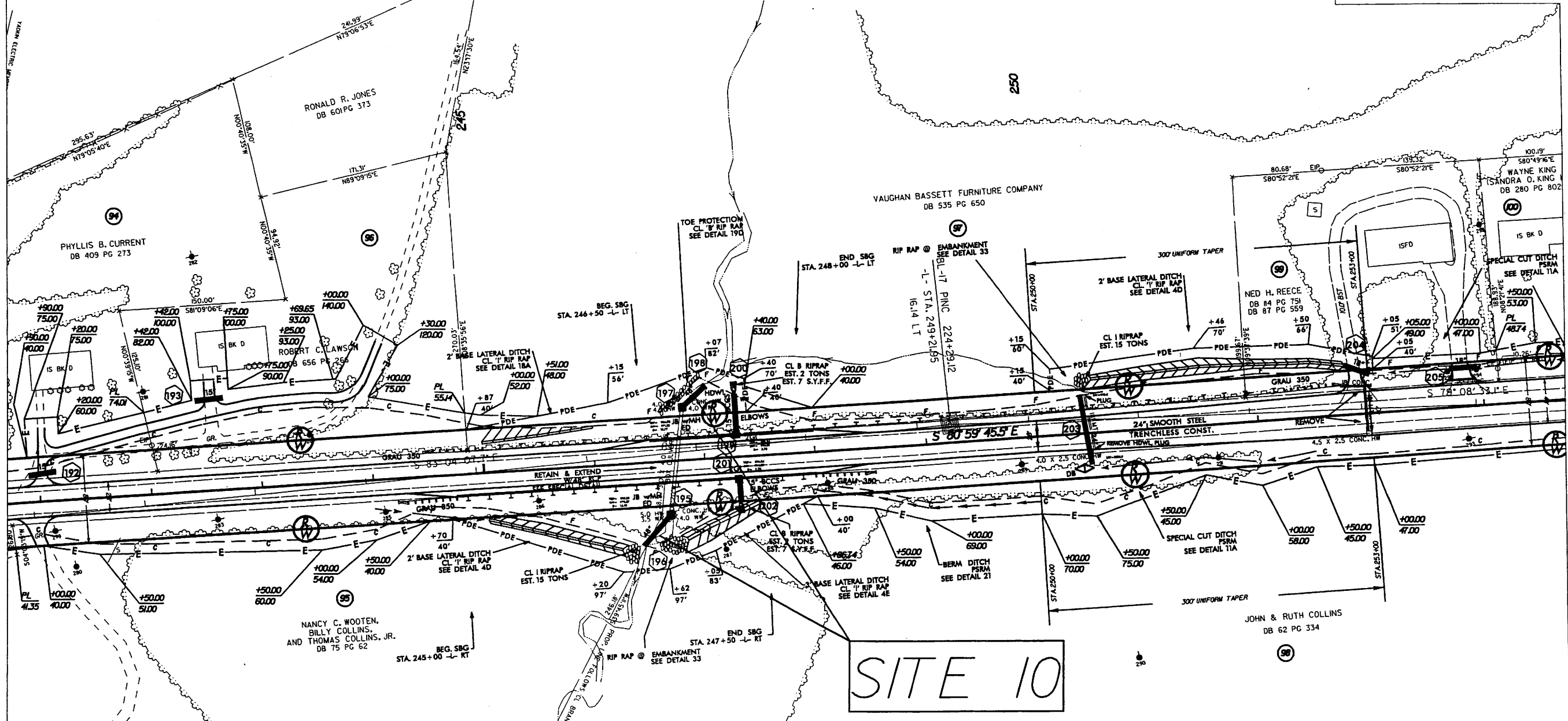
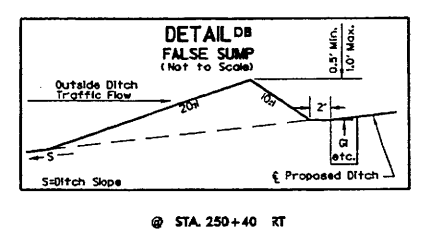
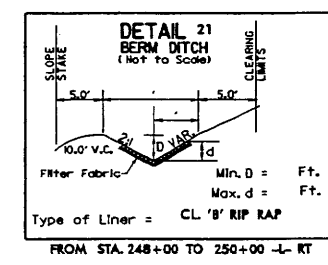
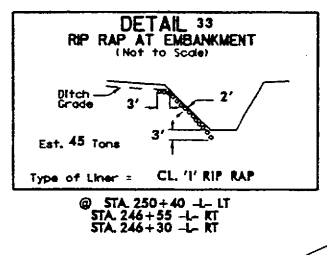
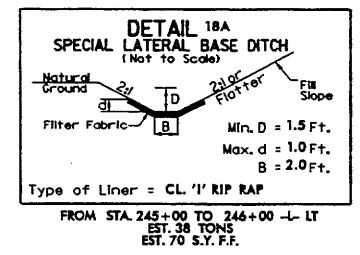

**NOTE**

FOR -L- PROFILE SEE SHEET 33  
ALL DRIVEWAY RADII ARE 15' UNLESS NOTED

MATCH LINE SHEET 20

MATCH LINE SHEET 22

8/17/99  
08-DEC-2004 15:27  
C:\pdx\p-3415\p-3415ps21.permt.site#10.dgn



8/17/99

PROJECT REFERENCE NO. <b>R-3415</b>	SHEET NO. <b>21</b>
RW SHEET NO.	
ROADWAY DESIGN ENGINEER	HYDRAULICS ENGINEER
<b>PRELIMINARY PLANS</b> DO NOT USE FOR CONSTRUCTION	

Sheet 28 of 28

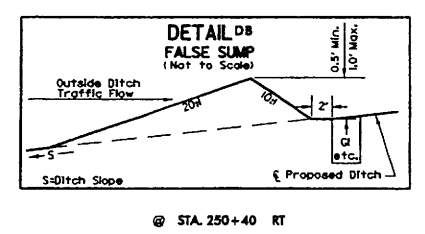
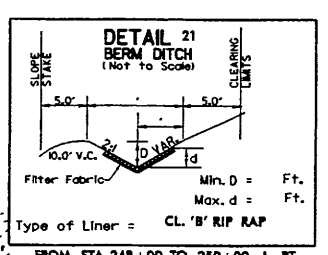
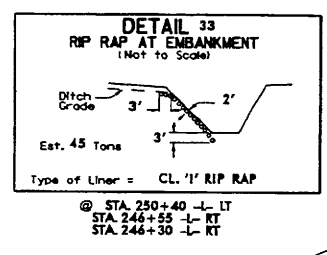
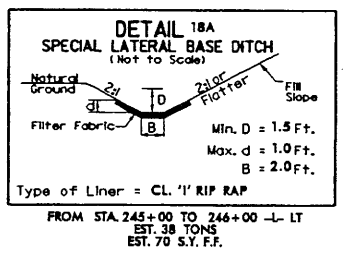

MATCH LINE SHEET 20

MATCH LINE SHEET 22

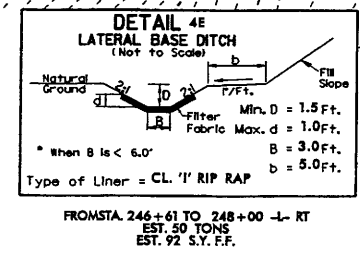
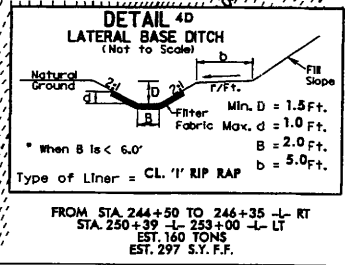
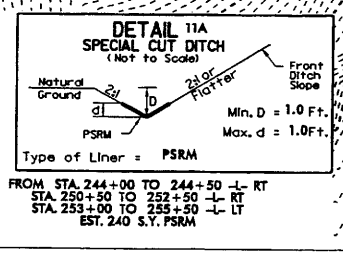
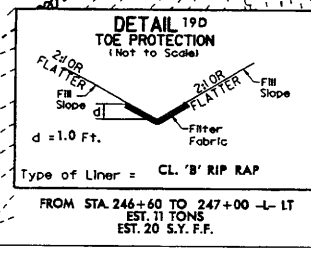
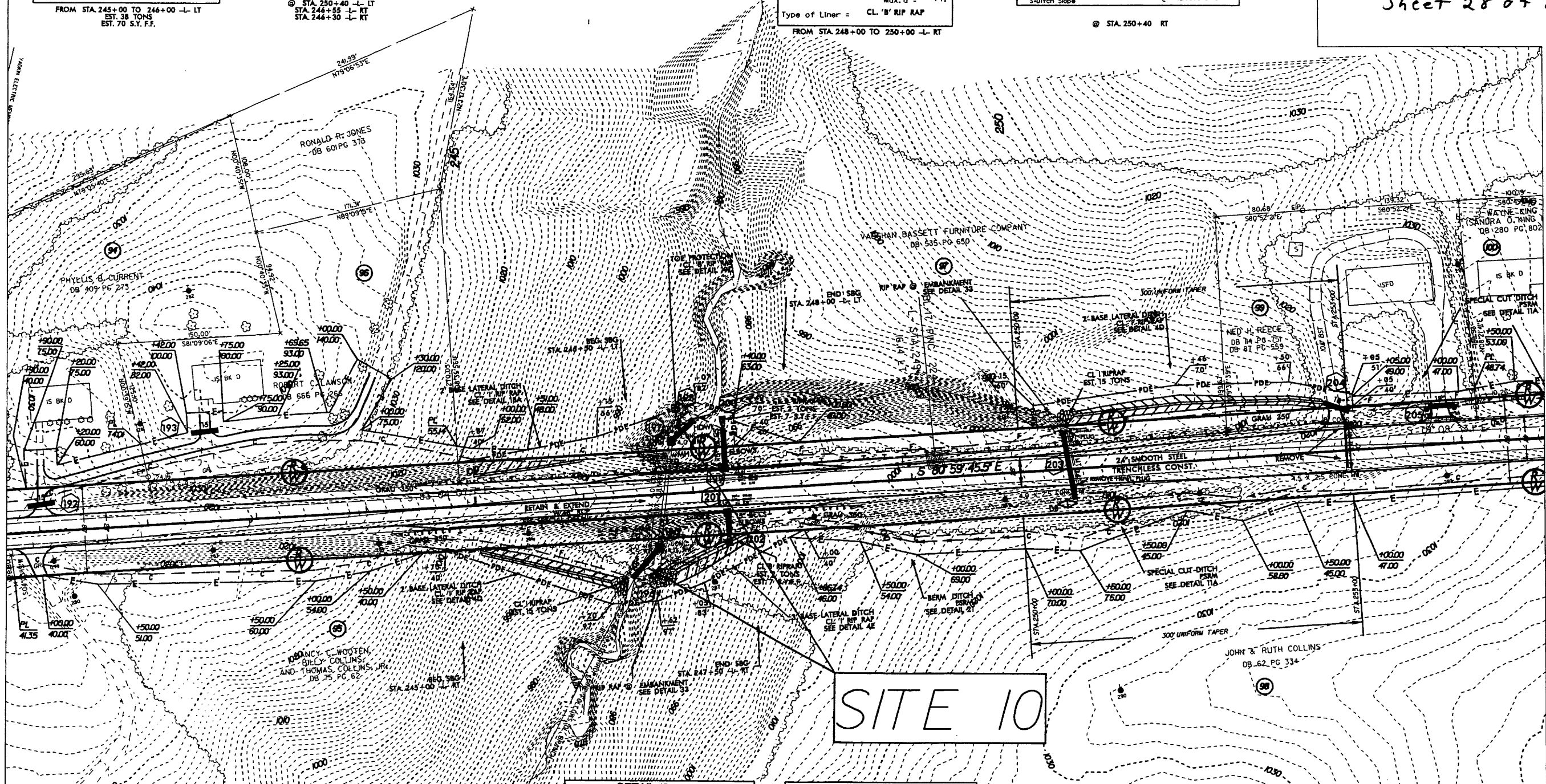

**NOTE**

FOR -L- PROFILE SEE SHEET 33  
ALL DRIVEWAY RADII ARE 15' UNLESS NOTED

REVISIONS

08-DEC-2004 15:23 415pa21\_permit.site\*10.dgn