



STATE OF NORTH CAROLINA
DEPARTMENT OF TRANSPORTATION

MICHAEL F. EASLEY
GOVERNOR

LYNDO TIPPETT
SECRETARY

November 10, 2003

MEMORANDUM TO: Mr. C. E. Lassiter, Jr., P.E.
Division 2 Engineer

FROM: Philip S. Harris, III, P.E., Manager
Office of the Natural Environment
Project Development and
Environmental Analysis Branch

SUBJECT: Pamlico County; NC 55 from SR 1127 (Bayleaf Road) to East of
SR 1129 (Bennett-Tingle Road); State Project No. 8.1170901;
T.I.P. # R-2539B

Attached are the U. S. Army Corps of Engineers Individual Permit, the DWQ 401 Water Quality Certification, and the NCDCM CAMA Major permit. All environmental permits have been received for the construction of this project.

PSH/eah

Attachment

cc: Ms. Debbie Barbour, P.E.
Mr. Jay Bennett, P.E.
Mr. David Chang, P.E.
Mr. Randy Garris, P.E.
Mr. Greg Perfetti, P.E.
Mr. Mark Staley
Mr. John F. Sullivan, III, FHWA
Mr. Omar Sultan
Mr. Jay Johnson, Division 2 Environmental Officer

MAILING ADDRESS:
NC DEPARTMENT OF TRANSPORTATION
PROJECT DEVELOPMENT AND ENVIRONMENTAL ANALYSIS
1598 MAIL SERVICE CENTER
RALEIGH NC 27699-1598

TELEPHONE: 919-715-1500
FAX: 919-715-1501

WEBSITE: www.NCDOT.ORG

LOCATION:
TRANSPORTATION BUILDING
1 SOUTH WILMINGTON STREET
RALEIGH NC

TIP Project No. R-2539 B

Widening of NC 55 From SR 1127 (Bayleaf Road) to East of SR 1129 (Bennett-Tingle Road) in Pamlico County Federal Aid Project No. STP-55(1) State Project No. 8.1170901

In addition to the standard Section 404 Individual Permit General Conditions, Section 401 Major Water Quality Certification Conditions, and Coastal Resources Commission (CAMA) Permit general conditions, the following special commitments have been agreed to by NCDOT.

COMMITMENTS DEVELOPED THROUGH PROJECT DEVELOPMENT AND DESIGN

All standard procedures and measures, including Best Management Practices for the Protection of Surface Waters and Sedimentation, will be implemented to avoid or minimize environmental impacts.

Roadway Design Unit, Division 2

The North Carolina Bicycling Highway Ocracoke Option designates NC 55 as a bicycle route from US 17 to SR 1005 (Neuse Road). The paved shoulder design for this project will accommodate the needs of bicycle traffic. In order to accommodate the needs of bicyclists through Reelsboro, the proposed curb and gutter section of roadway will be striped with a 3.6-meter (12-foot) center turn lane, 3.3-meter (11-foot) inside travel lanes, and 4.5-meter (14-foot) outside travel lanes.

The proposed bicycle accommodations have been incorporated into the design for R-2539 A. The portion of the project that extends through Reelsboro is part of R-2539 B and will be addressed in a future R-2539 B Construction Consultation.

Hydraulics Unit, Division 2 Construction

NCDOT's Best Management Practices include designing culverts to maintain the existing water surface conditions during normal flow periods. The culvert alignments and inverts will be designed to prevent interruptions to the natural stream flow. To ensure that the project will not impede fish migration, NCDOT will follow the draft design guidelines entitled "Stream Crossing Guidelines for Anadromous Fish Passage." As discussed in these guidelines, instream activities will be minimized during the spring migrating period of March, April, and May. Where spanning structures are not practicable, NCDOT will incorporate these guidelines into the culvert design.

Culvert designs for the project have incorporated both Best Management Practices and Stream Crossing Guidelines. Minimization of instream activities during the spring migrating period will be incorporated into the construction plans for the project.

Division 2 Construction

Notify PDEA and REU when construction is complete for the onsite mitigation sites at Upper Broad Creek, Deep Run Creek, and Goose Creek.

COMMITMENTS DEVELOPED THROUGH PERMITTING

In addition to the commitments specified in the Greensheet developed for construction of Section A dated 5/15/03, the following special commitments apply:

Division 2 Construction, R.E.U.

CAMA Condition 9) Turbidity curtains shall be used to isolate all work areas from the stream at Deep Run Creek and Goose Creek, including pile or casement installation, placement of riprap, excavation or filling. The turbidity curtains shall be installed parallel to the stream banks on each side of the stream. The turbidity curtains shall extend past the construction limits and attach to the silt fences containing the work site. The turbidity curtains shall not encircle a work area or extend across the streams. The turbidity curtains are to be properly maintained and retained in the water until construction is complete and shall be removed when turbidity within the curtains reaches ambient levels.

401 Conditions 17 and 29. During the construction of the project, no staging of equipment of any kind is permitted in Waters of the U.S. or protected riparian buffers. Heavy equipment must be operated from the banks rather than in any of the stream channels.

Division 2 Construction, Roadway Design, Structures

CAMA Condition 10) Debris resulting from demolition of the existing bridge, including deck components, shall not enter wetlands or waters of the United States, even temporarily.

CAMA Condition 12) The Goose Creek bridge shall be constructed utilizing top down construction methods with driven piles or drilled shaft construction, specifically piles shall not be jetted. Should jetting of any bridge piles become necessary, a modification to the permit will be required.

Division 2 Construction, R.E.U., Hydraulics, O.N.E.

Stream Mitigation

401 Condition 8. All channel relocations will be constructed in a dry work area and stabilized before stream flows are diverted. Channel relocations shall be allowed to stabilize for an entire growing season. Vegetation used for bank stabilization shall be limited to native woody species and should include establishment of a 30-foot wide wooded and adjacent 20-foot wide vegetated buffer on both sides of the relocated channel to the maximum extent possible. A transitional phase incorporating coir fiber and

seedling establishment is allowable. Also, rip-rap may be allowed if it is necessary to maintain the physical integrity of the stream, but the NCDOT must provide written justification and any calculations used to determine the extent of rip-rap coverage requested.

401 Condition 10. [Other than the original 135 feet proposed as onsite stream mitigation,] no additional compensatory mitigation for impacts to streams shall be required.

401 Condition 21. When design plans are completed for R-2539C, a modification to the 401 WQC and the Neuse River Riparian Buffer Certification shall be submitted with seven copies and fees to the NC DWQ. No construction activities that impact any wetlands, streams, surface waters, or buffers located in R-2539C shall begin until after NCDOT receives written modifications.

Wetland Mitigation

401 Condition 14. Prior to planting any of the vegetation for the wetland restoration sites, a planting plan shall be submitted to, and approved by, the NC DWQ. No species except those in the approved planting plan shall be planted at the wetland restoration sites.

CAMA Condition 14) Except as specified by conditions of this major modification, on-site mitigation will be carried out as described in the document titled “Restoration plan for swamp hardwood wetlands at existing bridge causeways of NC 55, Upper Broad Creek, Deep Run, and Goose Creek in Craven and Pamlico Counties” dated December 11, 2002 and revised on January 24, 2003 and August 29, 2003.

CAMA Condition 15) The existing causeways and railroad bed sites will be graded to an elevation sufficient to induce wetland propagation in and around the surrounding areas. The compacted ground will then be ripped to remove the soil compaction from the old railroad bed and for planting purposes. After ripping, the elevation of the ripped soils will be identical to the surrounding wetland elevation.

CAMA Condition 16) The NCDOT will ensure the removal of all unsuitable existing causeway fill material to prevent potential contamination of the adjacent water bodies. The NCDOT will fill any void left by the removal of this unsuitable existing causeway fill material with suitable organic substrate.

O.N.E., Division 2 Construction

CAMA Condition 17), 404 Condition a., 401 Condition 9. The final design for TIP No. R-2539B includes 0.05 acres of impacts to non-riverine wetlands in addition to what was authorized by the original CAMA permit for this project. Therefore, the NCDOT shall debit 0.10 acres (0.12 acres, per 404 permit) of non-riverine wetlands credits from the Croatan Wetland Mitigation Bank in addition to what was already required by the original CAMA permit. Therefore, the NCDOT shall debit a total of 28.70 acres of non-

riverine wetlands credits from the Croatan Mitigation Site for TIP No. R-2539. *No work within waters or wetlands authorized by the 404 permit shall begin until documentation has been received by the USACE that the credits have been debited from the Bank.*

CAMA Condition 19) Due to corrections made by the NCDOT to the calculation of wetland enhancement areas on TIP Nos. R-2539A and R-2539B, and the modification to final wetland and stream impacts based upon final design for TIP Nos. R-2539B and R-2539C, the NCDOT shall submit to DCM, the DWQ and the USACE a table summarizing the final wetland and stream impacts incurred by TIP No. R-2539A/B/C, along with the final compensatory mitigation plan proposed for these impacts. This information shall be submitted with the authorization request for TIP No. R-2539C. The NCDOT must receive approval from DCM, DWQ and USACE on the final compensatory mitigation plan *prior to initiating construction on TIP No. R-2539C.*

CAMA Condition 21) Based upon the estimates of wetland mitigation provided by the NCDOT in the 10/22/03 memorandum, the NCDOT anticipates a surplus of 2.84 acres of riverine wetland restoration credits and a surplus of 11.99 acres of riverine wetland enhancement credits after TIP No. R-2539 is complete. DCM does not object to the NCDOT's request to bank the remaining credits as compensatory mitigation for offsite riverine wetland impacts on future projects that are deemed appropriate by DCM. However, in order for DCM to agree with the request, the NCDOT must revise the document titled "Restoration Plan for Swamp Hardwood Wetlands at existing Bridge Causeways of NC 55, Upper Broad Creek, Deep Run, and Goose Creek in Craven and Pamlico Counties" dated December 11, 2002 and revised on January 24, 2003 and August 29, 2003. The NCDOT must submit the revised mitigation plan to DCM for approval, and receive approval from DCM, *prior to initiating any construction on TIP No. R-2539B.* (See permit for specific plan inclusions.)

O.N.E.

CAMA Condition 18) The annual monitoring report for the Croatan Mitigation Site shall include a debit ledger that reflects that credits for 28.70 acres of wetland restoration have been debited for TIP Nos. R-2539A/B/C. The debit ledger shall also show the remaining credits available at the Croatan Mitigation site.

CAMA Condition 20) In a memorandum to DCM, DWQ and USACE dated 10/22/03, the NCDOT submitted revised onsite riverine mitigation acreages for TIP No. R-2539A and TIP No. R-2539B. According to the NCDOT, removal of existing bridge and railroad causeway fill material in wetlands will result in 4.23 acres of riverine wetland restoration and 11.99 acres of riverine wetland enhancement. When DCM receives the revised workplan drawings depicting wetland restoration and wetland enhancement areas from the NCDOT as requested by Condition No. 2 of this permit, a final determination will be made as to whether the revised onsite riverine mitigation acreages are appropriate.

Roadside Environmental Unit, O.N.E

401 Condition 24. Riparian vegetation must be reestablished within the construction limits of the project by the end of the growing season following completion of construction.

Division 2 Construction, Design Services-Utilities, ROW-Utilities

CAMA Condition 25) Any relocation of utility lines that is not already depicted on the attached workplan drawings, or described within the attached permit application, will require additional authorization, either by way of a modification of this permit or by the utility company obtaining separate authorization.

401 Condition 22. All clearing of vegetation for the purpose of relocating overhead power lines within jurisdictional wetlands shall be performed without the use of mechanized equipment.

PERMIT EXPIRATION DATES:

404 Permit expires on December 31, 2006

401 WQC expires upon expiration of 404 or CAMA

CAMA Major Development permit expires on December 31, 2006

Restoration Plan for Swamp Hardwood Wetlands
at existing Bridge Causeways of NC 55
Upper Broad Creek, Deep Run, and Goose Creek
in Craven and Pamlico Counties

R-2539

December 11, 2002

1st Revision January 24, 2003

2nd Revision August 29, 2003

The NCDOT will perform on-site mitigation for riverine bottomland hardwood swamp at the NC 55 overpasses of Upper Broad Creek, Deep Run, and Goose Creek in Craven and Pamlico counties. The NCDOT will remove approximately 1.78 acres of existing bridge causeway fill in Section A and approximately ~~0.88~~ 2.45 acres in Section B in order to lengthen the bridges and restore the underlying wetlands.

~~The existing causeways will be removed and graded down approximately three feet below the grade of the surrounding wetlands. The excavated areas will be back filled with undercut material (muck) removed during the construction of R-2539. The existing causeways and railroad bed sites will be graded to an elevation sufficient to induce wetland propagation in and around the surrounding areas. This elevation will be identical to the surrounding wetland elevation. The compacted ground will then be ripped to remove the soil compaction from the old roadbed and for planting purposes.~~ The portions of the site with adequate aerial clearance will be revegetated with swamp hardwood trees. Since all species are not available every year from local nurseries, the seedling mixture will mimic the surrounding wetland to the maximum extent possible. The final species mix will be subject to agency review prior to planting. The species to be planted will include an equal representation of green ash (*Fraxinus pennsylvanica*), bald cypress (*Taxodium distichum*), yellow poplar (*Liriodendron tulipifera*), swamp black gum (*Nyssa biflora*), and water tupelo (*Nyssa aquatica*). Twelve- to eighteen-inch bareroot seedlings will be planted at a density of 680 trees per acre. We also expect natural seeding from the adjacent swamp hardwoods. The remaining portion, with restricted overhead clearance, will be seeded with grasses immediately following construction, in order to stabilize the site and allowed to revegetate naturally from the local herbaceous seed source. Total on-site riverine wetland mitigation anticipated for this project will be ~~2.66~~ 4.23 acres.

After planting has been completed, an initial evaluation will be performed to verify satisfactory planting technique and to determine initial species composition and density. Vegetation sampling plots will be established and permanently located within the three swamp hardwood mitigation areas.

Success criteria have been established to verify that the mitigation areas support vegetation necessary for a jurisdictional determination and that the restored area exhibits

wetland hydrology. Based on the success criteria listed below, an annual report summarizing mitigation will be submitted to the regulatory agencies for their review and acceptance. Five years after project completion, NCDOT will schedule an agency field meeting to determine whether the areas have attained jurisdictional wetland status.

Vegetation Monitoring

For swamp hardwood areas planted in tree species, an annual update will consist of photographs provided during the agency monitoring report meeting and brief report on the progress of these areas attaining wetland jurisdictional status. The vegetative characteristics of the restoration area will then be compared to the immediately adjacent existing wetland complex (Reference Site).

Hydrologic Monitoring

When the existing causeways were constructed, the swamp hardwood wetland systems impacted had at least some amount of standing water throughout most of the growing season. Therefore, it is reasonable to expect that the removal of the causeways and minor site preparation will restore the area to wetland status. The restored hydrology of the site will be assessed concurrently with the vegetation monitoring. The site will be evaluated to determine if the restored area exhibits signs of wetland hydrology. The site will be evaluated using the same criteria outlined in the 1987 Wetland Delineation Manual, published by the United States Army Corps of Engineers, for field identification of a jurisdictional wetland. The hydrologic characteristics of the restoration area will then be compared to the immediately adjacent existing wetland complex (Reference Site).



REPLY TO
ATTENTION OF:

DEPARTMENT OF THE ARMY
WILMINGTON DISTRICT, CORPS OF ENGINEERS
P.O. BOX 1890
WILMINGTON, NORTH CAROLINA 28402-1890

October 1, 2003



Regulatory Division

Action ID No. 199303531

Dr. Gregory J. Thorpe, Ph.D.
Environmental Management Director, PEDDA
North Carolina Department of Transportation
1548 Mail Service Center
Raleigh, North Carolina 27699-1548

Dear Mr. Thorpe:

Reference the Department of the Army (DA) permit issued to you on May 9, 2003, associated with the widening of approximately 14.2 miles of NC 55 from 0.7 miles east of US 17 in Bridgeton to NC 304 in Bayboro, Craven and Pamlico Counties, North Carolina (TIP R-2539, Federal Aid Project STP-55(1), State Project No. 8.1170901). Also reference your subsequent written request dated July 21, 2003, for a permit modification to:

1. Submit final permit drawings and relevant information for R-2539 Section B. The final design revisions resulted in two sites differing from those submitted with the original permit application.

Site 1, Permit Sheet 7 of 40. Because of low grade and minimal drainage potential of the natural ground elevation at this site, NCDOT proposes to install a V-ditch with 6:1 side slopes to drain the subgrade of the new road. The new ditch will drain 0.06 acres of non-riverine wetlands.

Site 4, Permit Sheet 10 of 40. At this site an area of mechanized clearing in wetlands has been changed to excavation to accommodate a drainage swale.

2. Mitigate for the additional non-riverine wetland impacts by restoring 28.72 acres of wetlands instead of the permitted 28.60 acres.

This modification request was coordinated with the North Carolina Division of Water Quality, and other appropriate State and Federal agencies. The coordination revealed no objections to this modification request. Therefore, the permit is hereby modified in accordance with the specific work activities described above and in the enclosed plans. It is understood that all conditions of the original permit remain applicable and that the expiration date is unchanged. In addition, the permittee will comply with the following special permit conditions:

a. The Permittee shall debit an additional .12 acres of non-riverine restoration acres from the Croatan Wetland Mitigation Bank. No work within waters or wetlands authorized by this permit shall begin until documentation has been received by the COE that the credits have been debited from the Bank in accordance with the Mitigation Banking Instrument signed April 2003, attached hereto and incorporated herein by reference. The NCDOT shall perform all activities required of the Bank Sponsor in the "Agreement To Establish The Croatan Mitigation Bank In Craven County, North Carolina," including the "Final Mitigation Plan," dated April 2002.

Any questions regarding this correspondence may be directed to Mr. Michael Bell, NCDOT Coordinator/Regulatory Project Manager at the Washington Regulatory Field Office, telephone (252) 975-1616, extension 26.

Sincerely,



for
Charles R. Alexander, Jr.
Colonel, US Army
District Engineer

Copies Furnished:

Ms. Cathey Brittingham
Division of Coastal Management
1638 Mail Service Center
Raleigh, North Carolina 27699-16387

Mr. John Hennessy
NCDENR-DWQ
Wetlands Section
1621 Mail Service Center
Raleigh, North Carolina 27699-1621

National Marine Fisheries Service
Pivers Island
Beaufort, North Carolina 28516

Mr. Gary Jordan
U.S. Fish and Wildlife Service
Fish and Wildlife Enhancement
Post Office Box 33726
Raleigh, North Carolina 27636-3726

Mr. Ronald Mikulak, Chief
Wetlands Regulatory Section - Region IV
Environmental Protection Agency
Atlanta Federal Center
100 Alabama Street, SW
Atlanta, Georgia 30365



Michael F. Easley, Governor
William G. Ross Jr., Secretary
North Carolina Department of Environment and Natural Resources

Alan W. Klimek, P.E. Director
Division of Water Quality
Coleen H. Sullins, Deputy Director
Division of Water Quality

4/11/03

October 27, 2003

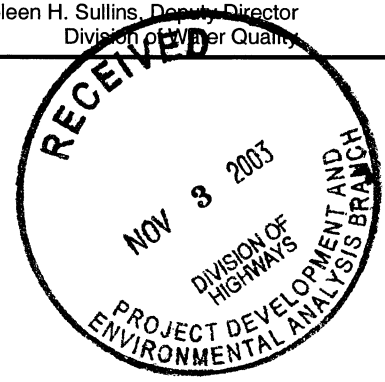

Dr. Gregory J. Thorpe, PhD., Manager
Planning and Environmental Branch
North Carolina Department of Transportation
1548 Mail Service Center
Raleigh, North Carolina, 27699-1548

Dear Dr. Thorpe:

Re: Modification to the 401 Water Quality Certification Pursuant to Section 401 of the Federal Clean Water Act, Widening of NC 55 from US 17 in Bridgeton to NC 304 in Bayboro in Craven and Pamlico Counties. WQC Project No. 021232

Attached hereto is a copy of modification to Certification No. 3415 issued to The North Carolina Department of Transportation on March 17, 2003. This certification authorizes the NCDOT to place fill in 1.87 acres of jurisdictional wetlands, excavate 0.25 acres of jurisdictional wetlands, perform mechanized clearing in 1.51 acres of jurisdictional wetlands, and drain 0.06 acres of jurisdictional wetlands. In addition, this certification authorizes impacts to 295 linear feet of streams, and impacts to 0.99 acres of protected riparian buffers in Zone 1 and 0.68 acres of protected riparian buffers in Zone 2. This certification modifies only segment B of the widening of NC 55 from Bridgeton to Bayboro and shall be constructed pursuant to the application dated on the July 21, 2003 for the NC 55 widening from Bridgeton to Bayboro, and the subsequent addendum dated October 8, 2003. All the authorized activities and conditions of the certification associated with the original Water Quality Certification dated March 17, 2003 and all subsequent modifications still apply except where superceded by this certification.

If we can be of further assistance, do not hesitate to contact us.

Sincerely,

[Handwritten Signature]
Alan W. Klimek, P.E.
Director

Attachments

cc: Wilmington District Corps of Engineers
Corps of Engineers Raleigh Field Office
DWQ Raleigh Regional Office
Central Files
File Copy





**Modification of 401 Water Quality Certification and ADDITIONAL CONDITIONS
 and Neuse River Buffer Rules**

THIS CERTIFICATION is issued in conformity with the requirements of Section 401 Public Laws 92-500 and 95-217 of the United States and subject to the North Carolina Division of Water Quality (DWQ) Regulations in 15 NCAC 2H, Section .0500, and 15 NCAC 2B .0233. This certification authorizes the NCDOT to place fill in 1.87 acres of jurisdictional wetlands, excavate 0.25 acres of jurisdictional wetlands, perform mechanized clearing in 1.51 acres of jurisdictional wetlands, and drain 0.06 acres of jurisdictional wetlands. In addition, this certification authorizes impacts to 295 linear feet of streams, and impacts to 0.99 acres of protected riparian buffers in Zone 1 and 0.68 acres of protected riparian buffers in Zone 2. This certification modifies only segment B of the widening of NC 55 from Bridgeton to Bayboro and shall be constructed pursuant to the application dated on the July 21, 2003 for the NC 55 widening from Bridgeton to Bayboro, and the subsequent addendum dated October 8, 2003. All the authorized activities and conditions of the certification associated with the original Water Quality Certification dated March 17, 2003 and all subsequent modifications still apply except where superceded by this certification. The impacts shall occur as described below:

Wetland & Surface Water Impacts in the Neuse River Basin

Section	Impacts to Wetlands (Acres)			Impacts to Streams (Feet)	Impacts to other Surface Waters (Acres)	Impacts to Buffers (Acres)	
	Fill in Wetlands	Excavation & Drainage	Mechanized Clearing			Zone 1	Zone 2
R-2539B (Original 401 WQC)	1.88	0.24	1.52	295.2	0.03	0.59	0.32
R-2539B (Additional Impacts with this Modification)	-0.01	0.01	-0.01	0	0	0.40	0.36
Total	1.87	0.25	1.51	295.2	0.03	0.99	0.68



Neuse River Riparian Buffer Impacts & Mitigation

Site	Zone 1 (Acres)	Zone 2 (Acres)
Site 2	0.11	0.06
Site 4	0.13	0.18
Site 5	0.11	0.07
Site 7	0.18	0.10
Site 13	0.30	0.16
Site 16	0.17	0.11
Total Additional Impacts	1.0	0.68

The application provides adequate assurance that the discharge of fill material into the waters of the Neuse and Cape Fear River Basins in conjunction with the proposed development will not result in a violation of applicable Water Quality Standards and discharge guidelines. Therefore, the State of North Carolina certifies that this activity will not violate the applicable portions of Sections 301, 302, 303, 306, 307 of PL 92-500 and PL 95-217 if conducted in accordance with the application and conditions hereinafter set forth.

This approval is only valid for the purpose and design that you submitted in your application, as described in the Public Notice. Should your project change, you are required to notify the DWQ and submit a new application. If the property is sold, the new owner must be given a copy of this Certification and approval letter, and is thereby responsible for complying with all the conditions. If additional wetland impacts, or stream impacts, for this project (now or in the future) exceed one acre or 150 linear feet, respectively, additional compensatory mitigation may be required as described in 15A NCAC 2H .0506 (h) (6) and (7). For this approval to remain valid, you are required to comply with all the conditions listed below. In addition, you should obtain all other federal, state or local permits before proceeding with your project including (but not limited to) Sediment and Erosion control, Coastal Stormwater, Non-discharge and Water Supply watershed regulations. This Certification shall expire three years from the date of the cover letter from DWQ or on the same day as the expiration date of the corresponding Corps of Engineers Permit, whichever is sooner.

Condition(s) of Certification:

- 1.) No waste, spoil, solids, or fill of any kind shall occur in wetlands, waters, or riparian areas beyond the footprint of the impacts depicted in the application. All construction activities, including the design, installation, operation, and maintenance of sediment and erosion control Best Management Practices, shall be performed so that no violations of state water quality standards, statutes, or rules occur.
- 2.) Erosion and sediment control practices must be in full compliance with all specifications governing the proper design, installation and operation and maintenance of such Best Management Practices:
 - a. The erosion and sediment control measures for the project must be designed, installed, operated, and maintained in accordance with the most recent version of the *North Carolina Sediment and Erosion Control Planning and Design Manual*.
 - b. The design, installation, operation, and maintenance of the sediment and erosion control measures must be such that they equal, or exceed, the requirements specified in the most recent version of the *North Carolina Sediment and Erosion Control Manual*. The devices shall be maintained on all construction sites, borrow sites, and waste pile (spoil) projects, including contractor-owned or leased borrow pits associated with the project.



- c. For borrow pit sites, the erosion and sediment control measures must be designed, installed, operated, and maintained in accordance with the most recent version of the *North Carolina Surface Mining Manual*.
 - d. The reclamation measures and implementation must comply with the reclamation in accordance with the requirements of the Sedimentation Pollution Control Act.
- 3.) During the construction of the project, DOT shall strictly adhere to the *Best Management Practices for the Protection of Surface Waters* (NCDOT March 1997), specifically using all applicable preventive and control measures during the design, construction, and maintenance of the project. These measures shall be implemented prior to any ground disturbing activities.
 - 4.) All sediment and erosion control measures shall not be placed in wetlands or waters to the maximum extent practicable. If placement of sediment and erosion control devices in wetlands and waters is unavoidable, they shall be removed and the natural grade restored after the Division of Land Resources has released the project;
 - 5.) If an environmental document is required, this Certification is not valid until a FONSI or ROD is issued by the State Clearinghouse. All water quality-related conditions of the FONSI or ROD shall become conditions of this Certification;
 - 6.) No live or fresh concrete shall come into contact with waters of the state until the concrete has hardened;
 - 7.) There shall be no excavation from or waste disposal into jurisdictional wetlands or waters associated with this permit without appropriate modification of this permit. Should waste or borrow sites be located in wetlands or stream, compensatory mitigation will be required since it is a direct impact from road construction activities.
 - 8.) All channel relocations will be constructed in a dry work area, and stabilized before stream flows are diverted. Channel relocations will be completed and stabilized prior to diverting water into the new channel. Whenever possible, channel relocations shall be allowed to stabilize for an entire growing season. Vegetation used for bank stabilization shall be limited to native woody species, and should include establishment of a 30 foot wide wooded and an adjacent 20 foot wide vegetated buffer on both sides of the relocated channel to the maximum extent practical. A transitional phase incorporating coir fiber and seedling establishment is allowable. Also, rip-rap may be allowed if it is necessary to maintain the physical integrity of the stream, but the applicant must provide written justification and any calculations used to determine the extent of rip-rap coverage requested.
 - 9.) Additional compensatory mitigation for impacts to non-riverine wetlands shall be done for 0.05 acres. Applying a replacement ration of 2:1, total mitigation for 0.12 acres of non-riverine wetlandsshall be provided as described below:

Mitigation Site	Acres of WL Debited from Site	Type of Mitigation	Replacement Ratio	Acres of Mitigation Credited
Croatan Mitigation Site	0.10	Restoration	1:1	0.10



- 10.) No additional compensatory mitigation for impacts to streams shall be required.
- 11.) No additional compensatory mitigation is required for the additional 0.76 acres of impacts to Neuse River Riparian Buffers. Compensatory mitigation credits shall be generated for 0.40 acres of Neuse River Riparian Buffers planted at Site 13 from Station 134+75 to Station 137+30.
- 12.) Placement of culverts and other structures in waters, streams, and wetlands must be placed below the elevation of the streambed by one foot for all culverts with a diameter greater than 48 inches, and 20 percent of the culvert diameter for culverts having a diameter less than 48 inches, to allow low flow passage of water and aquatic life. Design and placement of culverts and other structures including temporary erosion control measures shall not be conducted in a manner that may result in dis-equilibrium of wetlands or stream beds or banks, adjacent to or upstream and down stream of the above structures. The applicant is required to provide evidence that the equilibrium shall be maintained if requested in writing by DWQ.
- 13.) All stormwater runoff shall be directed to sheetflow through stream buffers at nonerosive velocities, unless approved otherwise by this certification.
- 14.) Prior to planting any of the vegetation for the wetland restoration sites located at Station 75+55 to Station 76+55, and Station 148+40 to Station 150+60, a planting plan shall be submitted to, and approved by, the NC Division of Water Quality. No species except those in the approved planting plan shall be planted at the aforementioned restoration site.
- 15.) For the aforementioned wetland mitigation sites located from Station 75+55 to Station 76+55, and from Station 148+40 to Station 150+60, NCDOT shall plant 680 stems/acre of the approved planting list. Vegetation success shall be measured by survivability over a 5-year monitoring period. Survivability will be based on 320 stems/acre after 3 years and 260 stems after 5 years. A survey of vegetation during the growing season shall be conducted annually over the 5-year monitoring period, and submitted to the NC Division of Water Quality. If the surviving vegetation densities are below the required thresholds after the 5-year monitoring period, the site may still be declared successful, at the discretion, and with written approval from, the NC Division of Water Quality.
- 16.) For the wetland mitigation sites located from Station 75+55 to Station 76+55, and Station 148+40 to Station 150+60, hydrologic success of the sites will be attained by restoration of a hydrologic regime that results in inundation or saturation of the soils within 12 inches of the ground surface for at least 12.5 percent of the growing season, and inundation or saturation of the soils within 12 inches of the ground surface within 20 percent of hydrologic monitoring gauges located in the adjacent wetland reference. The hydrologic monitoring shall persist for a total of 5 years. In addition, after the 5-year monitoring period, if the monitoring requirements are not met, the site may still be declared successful, at the discretion, and with written approval from, the NC Division of Water Quality.
- 17.) During the construction of the project, no staging of equipment of any kind is permitted in waters of the U.S., or protected riparian buffers.
- 18.) The onsite mitigation sites located at stations L 41+50 (Upper Broad Creek), L 76+25 (Deep Run Creek), L 149+40 (Goose Creek), will result in a total of 4.23 acres of riverine wetland restoration credit. In addition, they will generate 11.99 acres of riverine wetland enhancement credit. Of the 4.23 acres of wetland restoration, 1.39 acres were authorized for use on this project in the original Water Quality Certification dated March 17, 2003. The remaining 2.84 acres of restoration credits, and 11.99 acres of enhancement credits are available for use on other DOT projects located in the same 8 digit hydrologic unit as the sites.



- 19.) The post-construction removal of any temporary bridge structures will need to return the project site to its preconstruction contours and elevations. The revegetation of the impacted areas with appropriate native species may also be necessary.
- 20.) No changes to the horizontal or vertical placement of the stormwater outfall locations, the horizontal or vertical placement of the culverts, the horizontal or vertical placement of bridges, the horizontal or vertical placement of grassed swales, or the horizontal or vertical placement of open ditches is permitted without written approval from the NC Division of Water Quality 401 Wetlands Unit. In addition, no changes to the flow spreader locations or designs, preformed scour hole locations or designs are permitted without written approval from the NC Division of Water Quality 401 Wetlands Unit. Any request for changes to the referenced items above will require submittal of a modification request, with seven copies, and corresponding fees will need to be submitted to the North Carolina Division of Water Quality.
- 21.) When final design plans are completed for R-2539 Section C, a modification to the 401 Water Quality Certification and the Neuse River Riparian Buffer Certification shall be submitted with seven copies and fees to the NC Division of Water Quality. Final designs shall reflect all appropriate avoidance, minimization, and mitigation for impacts to wetlands, streams, and other surface waters, and buffers. No construction activities that impact any wetlands, streams, surface waters, or buffers located in R-2539 Section shall begin until after NCDOT applies for, and receives a written modification 401 Water Quality Neuse River Riparian Buffer Certification from the NC Division of Water Quality.
- 22.) In accordance with commitments made in your application, all clearing of vegetation for purpose of relocating overhead power lines within jurisdictional wetlands shall performed without the use of mechanized equipment.
- 23.) All fill slopes located in jurisdictional wetlands shall be placed at slopes no flatter than 3:1.
- 24.) Riparian vegetation must be reestablished within the construction limits of the project by the end of the growing season following completion of construction.
- 25.) Culverts that are less than 48-inch in diameter should be buried to a depth equal to or greater than 20% of their size to allow for aquatic life passage. Culverts that are 48-inch in diameter or larger should be buried at least 12 inches below the stream bottom to allow natural stream bottom material to become established in the culvert following installation and to provide aquatic life passage during periods of low flow. These measurements must be based on natural thalweg depths.
- 26.) The dimension, pattern and profile of the stream above and below the crossing should not be modified by widening the stream channel or reducing the depth of the stream. Disturbed floodplains and streams should be restored to natural geomorphic conditions.
- 27.) Any riprap used must not interfere with thalweg performance and aquatic life passage during low flow conditions.
- 28.) Heavy equipment must be operated from the banks rather than in any of the stream channels in order to minimize sedimentation and reduce the likelihood of introducing other pollutants into the stream.
- 29.) All mechanized equipment operated near surface waters must be regularly inspected and maintained to prevent contamination of stream waters from fuels, lubricants, hydraulic fluids, or other toxic materials.
- 30.) The presence of equipment in the channels must be minimized. Under no circumstances must rock, sand or other materials be dredged from the wetted stream channel under authorization of this permit, except in the immediate vicinity of the culverts.



- 31.) All work shall be performed during low flow conditions.
- 32.) Discharging hydroseed mixtures and washing out hydroseeders and other equipment in or adjacent to surface waters is prohibited.
- 33.) Upon completion of the project, the NCDOT shall complete and return the enclosed "Certificate of Completion" form to notify NCDWQ when all work included in the 401 Certification has been completed. The responsible party shall complete the attached form and return it to the 401/Wetlands Unit of the NC Division of Water Quality upon completion of the project. NCDOT is strongly advised to send in photographs upstream and downstream of each structure to document correct installation.

Violations of any condition herein set forth may result in revocation of this Certification and may result in criminal and/or civil penalties. This Certification shall become null and void unless the above conditions are made conditions of the Federal 404 and/or Coastal Area Management Act Permit. This Certification shall expire upon the expiration of the 404 or CAMA permit.

If this Certification is unacceptable to you have the right to an adjudicatory hearing upon written request within sixty (60) days following receipt of this Certification. This request must be in the form of a written petition conforming to Chapter 150B of the North Carolina General Statutes and filed with the Office of Administrative Hearings, P.O. Box 27447, Raleigh, N.C. 27611-7447. If modifications are made to an original Certification, you have the right to an adjudicatory hearing on the modifications upon written request within sixty (60) days following receipt of the Certification. Unless such demands are made, this Certification shall be final and binding.

This the 27th day of October 2003

DIVISION OF WATER QUALITY

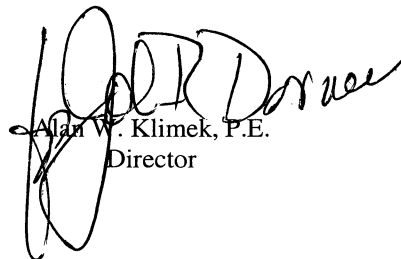

Alan W. Klimek, P.E.
Director

Modification to WQC No. 3415



DWQ Project No.: _____ County: _____

Applicant: _____

Project Name: _____

Date of Issuance of 401 Water Quality Certification: _____

Certificate of Completion

Upon completion of all work approved within the 401 Water Quality Certification or applicable Buffer Rules, and any subsequent modifications, the applicant is required to return this certificate to the 401/Wetlands Unit, North Carolina Division of Water Quality, 1621 Mail Service Center, Raleigh, NC, 27699-1621. This form may be returned to DWQ by the applicant, the applicant's authorized agent, or the project engineer. It is not necessary to send certificates from all of these.

Applicant's Certification

I, _____, hereby state that, to the best of my abilities, due care and diligence was used in the observation of the construction such that the construction was observed to be built within substantial compliance and intent of the 401 Water Quality Certification and Buffer Rules, the approved plans and specifications, and other supporting materials.

Signature: _____ Date: _____

Agent's Certification

I, _____, hereby state that, to the best of my abilities, due care and diligence was used in the observation of the construction such that the construction was observed to be built within substantial compliance and intent of the 401 Water Quality Certification and Buffer Rules, the approved plans and specifications, and other supporting materials.

Signature: _____ Date: _____

Engineer's Certification

_____ Partial _____ Final

I, _____, as a duly registered Professional Engineer in the State of North Carolina, having been authorized to observe (periodically, weekly, full time) the construction of the project, for the Permittee hereby state that, to the best of my abilities, due care and diligence was used in the observation of the construction such that the construction was observed to be built within substantial compliance and intent of the 401 Water Quality Certification and Buffer Rules, the approved plans and specifications, and other supporting materials.

Signature _____ Registration No. _____

Date _____

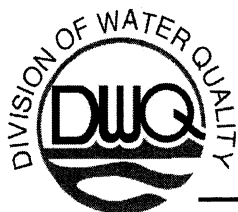

Michael F. Easley, Governor
William G. Ross Jr., Secretary
North Carolina Department of Environment and Natural Resources

Alan W. Klimek, P.E. Director
Division of Water Quality
Coleen H. Sullins, Deputy Director
Division of Water Quality

file
AS

October 27, 2003
DWQ No. 021232
Pamlico County

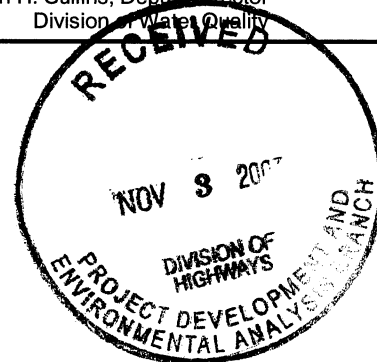

Dr. Gregory J. Thorpe, PhD., Manager
Planning and Environmental Branch
North Carolina Department of Transportation
1548 Mail Service Center
Raleigh, North Carolina, 27699-1548

Re: Pamlico County, Widening of NC 55 from Bridgeton to Bayboro,
Federal Aid Project No. STP-55(1), State Project No. 8.1170901; TIP R-2539B.
UT to Deep Creek [27-103; C NSW]

APPROVAL of NEUSE RIVER BUFFER RULES MINOR VARIANCE with ADDITIONAL CONDITIONS

Dear Dr. Thorpe,

You have our approval, in accordance with the attached conditions, to install a preformed scour in Zone 2 of protected riparian buffers for the purpose of widening of NC 55 from Bridgeton to Bayboro. This authorization permits 3.87 square feet of impacts to protected Neuse River Riparian Buffers to install a preformed scour hole. The preformed scour hole will result in stormwater discharging through the remainder of the buffers as diffuse flow at nonerosive velocities. The preformed scour hole and stormwater collection system that discharges to it shall be constructed according to the design Detail L included in your application dated July 21, 2003 and conditions listed below. This approval shall act as your Authorization Certificate as required within the Neuse River Area Protection Rules (15A NCAC 2B .0233). In addition, you should get any other required federal, state or local permits before you go ahead with your project including (but not limited to) Sediment and Erosion Control.

This approval is only valid for the purpose and design that you described in your application dated July 21, 2003. If you change your project, you must notify us and you may be required to send us a new application. If the property is sold, the new owner must be given a copy of this authorization and approval letter and is thereby responsible for complying with all conditions. For this approval to be valid, you must follow the conditions listed below.

- No changes to the horizontal or vertical placement of the stormwater outfall locations, the horizontal or vertical placement of the culverts, the horizontal or vertical placement of bridges, the horizontal or vertical placement of grassed swales, or the horizontal or vertical placement of open ditches is permitted without written approval from the NC Division of Water Quality 401 Wetlands Unit. In addition, no changes to the flow spreader locations or designs, preformed scour hole locations or designs are permitted without written approval from the NC Division of Water Quality 401 Wetlands Unit. Any request for changes to the referenced items above will require submittal of a modification request, with seven copies, and corresponding fees will need to be submitted to the North Carolina Division of Water Quality.

If you do not accept any of the conditions of this authorization, you may ask for an adjudicatory hearing. You must act within 60 days of the date that you receive this letter. To ask for a hearing, send a written petition, which conforms to Chapter 150B of the North Carolina General Statutes to the Office of Administrative Hearings, P.O. Box 27447, Raleigh, N.C. 27611-7447. This authorization and its conditions are final and binding unless you ask for a hearing.





Michael F. Easley, Governor
William G. Ross Jr., Secretary
North Carolina Department of Environment and Natural Resources
Alan W. Klimek, P.E. Director

This letter completes the review of the Division of Water Quality under the "No Practical Alternatives" determination required in 15A NCAC 2B .0233(8). If you have any questions, please contact John Hennessy at 919-733-5694.

Sincerely,

A handwritten signature in black ink, appearing to read "Alan W. Klimek". The signature is fluid and cursive, with a large, sweeping flourish at the end.

Alan W. Klimek, P.E.
Director

cc: US Army Corps of Engineers Washington Field Office
DWQ Washington Regional Office
File Copy
Central Files

C:\ncdot\R-2539\wqc\021232 R-2539 Minor Variance Approval.doc



4/10/03

North Carolina Department of Environment and Natural Resources
Division of Coastal Management

Michael F. Easley, Governor

Donna D. Moffitt, Director

William G. Ross Jr., Secretary

October 31, 2003

Greg Thorpe, PhD, Manager
Project Development and Environmental Analysis
N.C. Department of Transportation
1548 Mail Service Center
Raleigh, NC 27699-1548

Dear Dr. Thorpe:

The enclosed permit constitutes authorization under the Coastal Area Management Act, and where applicable, the State Dredge and Fill Law, for you to proceed with your project proposal. The original (buff-colored form) is retained by you and it must be available on site when the project is inspected for compliance. Please sign both the original and the copy and return the copy to this office in the enclosed envelope. Signing the permit and proceeding means you have waived your right of appeal described below.

If you object to the permit or any of the conditions, you may request a hearing pursuant to NCGS 113A-121.1 or 113-229. Your petition for a hearing must be filed in accordance with NCGS Chapter 150B with the Office of Administrative Hearings, 6714 Mail Service Center, Raleigh, NC 27611-6714, (919) 733-2698 within twenty (20) days of this decision on your permit. You should also be aware that if another qualified party submits a valid objection to the issuance of this permit within twenty (20) days, the matter must be resolved prior to work initiation. The Coastal Resources Commission makes the final decision on any appeal.

The project plan is subject to those conditions appearing on the permit form. Otherwise, all work must be carried out in accordance with your application. Modifications, time extensions, and future maintenance require additional approval. Please read your permit carefully prior to starting work and review all project plans, as approved. If you are having the work done by a contractor, it would be to your benefit to be sure that he fully understands all permit requirements.

From time to time, Department personnel will visit the project site. To facilitate this review, we request that you complete and mail the enclosed Notice Card just prior to work initiation. However, if questions arise concerning permit conditions, environmental safeguards, or problem areas, you may contact Department personnel at any time for assistance. By working in accordance with the permit, you will be helping to protect our vitally important coastal resources.

Sincerely,

Douglas V. Huggett
Major Permits and Consistency Manager

Enclosure

1638 Mail Service Center, Raleigh, North Carolina 27699-1638
Phone: 919-733-2293 \ FAX: 919-733-1495 \ Internet: <http://dcm2.enr.state.nc.us>

An Equal Opportunity \ Affirmative Action Employer - 50% Recycled \ 10% Post Consumer Paper

Permit Class
MODIFICATION/MAJOR

Permit Number
55-03

STATE OF NORTH CAROLINA
Department of Environment and Natural Resources
and
Coastal Resources Commission

Permit

for

Major Development in an Area of Environmental Concern
pursuant to NCGS 113A-118

Excavation and/or filling pursuant to NCGS 113-229

Issued to **N.C. Department of Transportation, 1548 Mail Service Center, Raleigh, NC 27699-1548**

Authorizing development in Craven and Pamlico County at Upper Broad Creek and Goose Creek, NC 55

Widening from Bridgeton to Bayboro, as requested in the permittee's application dated 8/29/03, 10/22/03 and
10/29/03, including the attached workplan drawings (103): 101 rcvd 7/24/03; 1 rcvd 10/23/03; & 1 rcvd 10/29/03.

This permit, issued on 10/31/03, is subject to compliance with the application (where consistent with the permit), all applicable regulations, special conditions and notes set forth below. Any violation of these terms may be subject to fines, imprisonment or civil action; or may cause the permit to be null and void.

- 1) This major modification authorizes construction of Transportation Improvement Program (TIP) Number R-2539B, from east of SR 1127 (Bayleaf Road) to east of SR 1129 (Bennett-Tingle Road) in Pamlico County, a distance of approximately 6.2 miles, as depicted on the attached workplan drawings.
- 2) The following workplan drawings (6) received on 9/16/03 are not authorized by this major modification because they depict an inaccurate calculation of wetland enhancement areas. Revised workplan drawings depicting wetland restoration and wetland enhancement areas must be submitted to the Division of Coastal Management (DCM), and receive approval from DCM, prior to the initiation of any construction on TIP No. R-2539B.
 - 1/2 size workplan drawings dated 9/11/03: 9, 10, 27, 28, 31 and 31A.

(See attached sheets for Additional Conditions)

This permit action may be appealed by the permittee or other qualified persons within twenty (20) days of the issuing date. An appeal requires resolution prior to work initiation or continuance as the case may be.

This permit must be accessible on-site to Department personnel when the project is inspected for compliance.

Any maintenance work or project modification not covered hereunder requires further Division approval.

All work must cease when the permit expires on

December 31, 2006

In issuing this permit, the State of North Carolina agrees that your project is consistent with the North Carolina Coastal Management Program.

Signed by the authority of the Secretary of DENR and the Chairman of the Coastal Resources Commission.

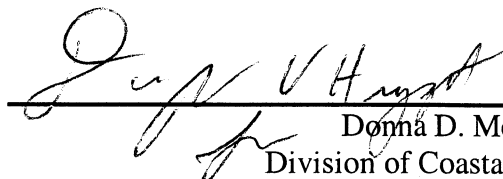
Donna D. Moffitt, Director
Division of Coastal Management

This permit and its conditions are hereby accepted.

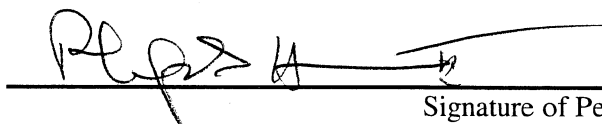
Signature of Permittee

ADDITIONAL CONDITIONS

- 3) The following workplan drawings (103) are authorized by this major modification:
- Permit drawing 31 of 40, dated 5/31/01.
 - Permit drawings 11, 12, 13, 14, 20 and 21 of 40, dated 5/22/02.
 - Permit drawing 37A of 40 dated 12/18/02.
 - Permit drawings 7-10, 16-18, 19 (1 of 2), 22-26 and 32-38 of 40, dated 4/4/03.
 - Permit drawing 15 of 40 dated 10/6/03.
 - Permit drawing 19 (2 of 2) of 40 dated 10/21/03.
 - Buffer drawing B8 of 12, dated 12/18/02.
 - Buffer drawing B9 of 12, dated 4/7/03.
 - Buffer drawing B5 of 12, dated 6/24/03.
 - Buffer drawings B6 and B10 of 12, dated 7/9/03.
 - Buffer drawing B7 of 12 dated 10/6/03.
 - Utility drawings U2-U10 of 13, dated 1/6/03.
 - ½ size workplan drawing 13, dated 2/6/03.
 - ½ size workplan drawings 4-12, 14-27, 29-51, dated 5/22/03.
 - ½ size workplan drawing 28, dated 5/23/03.
 - ½ size workplan drawings 2, 2A, 2B, 2C, 2D, 2E, 2F, 2G, 2H, and 2I, dated as received on 7/24/03.
- 4) The permittee must submit a request for, and receive, CAMA authorization prior to initiating any construction on the remaining segment of this project (TIP No. R-2539C). Final workplan drawings for TIP No. R-2539C, from SR 1129 to NC 304 in Bayboro, shall be submitted to DCM when they are complete to determine appropriate permit processing requirements.
- NOTE:** TIP No. R-2539B will permanently impact approximately 295 linear feet of stream channel, including 0.03 acres of fill in surface waters.
- NOTE:** TIP No. R-2539B will permanently impact approximately 3.69 acres of 404 jurisdictional wetlands, including 0.85 acres of riverine wetlands and 2.84 acres of non-riverine wetlands. The wetland impacts are due to 1.87 acres of fill, 1.59 acres of mechanized clearing, 0.25 acres of excavation and 0.06 acres of drainage. There will also be 0.01 acres of temporary wetland impacts due to pilings for the temporary work bridge at Deep Run Creek and 0.39 acres of temporary wetland impacts due to hand clearing for utility relocations.
- 5) If the permittee determines that additional permanent and/or temporary impacts will occur that are not shown on the attached workplan drawings, additional authorization from DCM will be required.
- 6) Live concrete shall not be allowed to contact the water in or entering into Waters of the State.
- 7) Placement of riprap shall be limited to the areas as depicted on the attached workplan drawings. The riprap material must be free from loose dirt or any pollutant. It must be of a size sufficient to prevent its movement from the site by wave or current action. The riprap material must consist of clean rock or masonry materials such as but not limited to granite or broken concrete.

ADDITIONAL CONDITIONS

- 8) In accordance with environmental commitments made within the original cover letter for TIP No. R-2539, dated 8/13/02, construction related impacts associated with the proposed action will be minimized through the use of High Quality Waters erosion and sediment control measures.
- 9) Turbidity curtains shall be used to isolate all work areas from the stream at Deep Run Creek and Goose Creek, including pile or casement installation, placement of riprap, excavation or filling. The turbidity curtains shall be installed parallel to the stream banks on each side of the stream. The turbidity curtains shall extend past the construction limits and attach to the silt fences containing the work site. The turbidity curtains shall not encircle a work area or extend across the streams. The turbidity curtains are to be properly maintained and retained in the water until construction is complete and shall be removed when turbidity within the curtains reaches ambient levels.

NOTE: Based on coordination with the N.C. Wildlife Resources Commission (WRC) and the N.C. Division of Marine Fisheries (DMF), the Project Commitment made by the permittee within the Environmental Assessment (EA) dated 10/8/07 and the Finding of No Significant Impact (FONSI) dated 9/14/00 to conform with the NCDOT official policy entitled "Stream Crossing Guidelines for Anadromous Fish Passage (May 12, 1997), including a requirement that instream activities be avoided from February 15 to June 15, does not apply to TIP No. R-2539B.

Bridge Replacement, Goose Creek

- 10) Debris resulting from demolition of the existing bridge, including deck components, shall not enter wetlands or waters of the United States, even temporarily.
- 11) All excavated materials and debris associated with the removal of the existing bridge, the existing causeway fill material and the associated concrete retaining wall will be disposed of on an approved upland site.
- 12) The bridge shall be constructed utilizing top down construction methods with driven piles or drilled shaft construction, specifically piles shall not be jetted. Should jetting of any bridge piles become necessary, a modification to this permit will be required.

Stormwater Management

- 13) The N.C. Division of Water Quality (DWQ) approved TIP No. R-2539B under stormwater management rules of the Environmental Management Commission (EMC) under Stormwater Permit No. SW7020722 on 10/7/02. Any violation of the permit approved by the DWQ will be considered a violation of this CAMA permit. If required, a Stormwater Management Permit must be obtained for TIP No. R-2539C, and a copy provided to DCM, prior to initiating any construction of TIP No. R-2539C.

ADDITIONAL CONDITIONS

Mitigation

- 14) Except as specified by conditions of this major modification, on-site mitigation will be carried out as described in the document titled "Restoration plan for swamp hardwood wetlands at existing bridge causeways of NC 55, Upper Broad Creek, Deep Run, and Goose Creek in Craven and Pamlico Counties" dated December 11, 2002 and revised on January 24, 2003 and August 29, 2003.
- 15) The existing causeways and railroad bed sites will be graded to an elevation sufficient to induce wetland propagation in and around the surrounding areas. The compacted ground will then be ripped to remove the soil compaction from the old railroad bed and for planting purposes. After ripping, the elevation of the ripped soils will be identical to the surrounding wetland elevation.
- 16) The permittee will ensure the removal of all unsuitable existing causeway fill material to prevent potential contamination of the adjacent water bodies. The permittee will fill any void left by the removal of this unsuitable existing causeway fill material with suitable organic substrate.
- 17) The final design for TIP No. R-2539B includes 0.05 acres of impacts to non-riverine wetlands in addition to what was authorized by the original CAMA permit for this project. Therefore, the permittee shall debit 0.10 acres of non-riverine wetlands credits from the Croatan Mitigation Site in addition to what was already required by the original CAMA permit. Therefore, the permittee shall debit a total of 28.70 acres of non-riverine wetlands credits from the Croatan Mitigation Site for TIP No. R-2539.
- 18) The annual monitoring report for the Croatan Mitigation Site shall include a debit ledger that reflects that credits for 28.70 acres of wetland restoration have been debited for TIP Nos. R-2539A/B/C. The debit ledger shall also show the remaining credits available at the Croatan Mitigation site.
- 19) Due to corrections made by the permittee to the calculation of wetland enhancement areas on TIP No. R-2539A and TIP No. R-2539B, and the modification to final wetland and stream impacts based upon final design for TIP No. R-2539B and TIP No. R-2539C, the permittee shall submit to DCM, the N.C. Division of Water Quality (DWQ) and the U.S. Army Corps of Engineers (USACE) a table summarizing the final wetland and stream impacts incurred by TIP No. R-2539A/B/C, along with the final compensatory mitigation plan proposed for these impacts. This information shall be submitted with the authorization request for TIP No. R-2539C. The permittee must receive approval from DCM, DWQ and USACE on the final compensatory mitigation plan prior to initiating construction on TIP No. R-2539C.
- 20) In a memorandum to DCM, DWQ and USACE dated 10/22/03, the permittee submitted revised onsite riverine mitigation acreages for TIP No. R-2539A and TIP No. R-2539B. According to the permittee, removal of existing bridge and railroad causeway fill material in wetlands will result in 4.23 acres of riverine wetland restoration and 11.99 acres of riverine wetland enhancement. When DCM receives the revised workplan drawings depicting wetland restoration and wetland enhancement areas from the permittee as requested by Condition No. 2 of this permit, a final determination will be made as to whether the revised onsite riverine mitigation acreages are appropriate.

ADDITIONAL CONDITIONS

- 21) Based upon the estimates of wetland mitigation provided by the permittee in the 10/22/03 memorandum, the permittee anticipates a surplus of 2.84 acres of riverine wetland restoration credits and a surplus of 11.99 acres of riverine wetland enhancement credits after TIP No. R-2539 is complete. DCM does not object to the permittee's request that they be allowed to bank the remaining credits as compensatory mitigation for offsite riverine wetland impacts on future projects that are deemed appropriate by DCM. However, in order for DCM to agree with the permittee's request, the permittee must revise the document titled "Restoration Plan for Swamp Hardwood Wetlands at existing Bridge Causeways of NC 55, Upper Broad Creek, Deep Run, and Goose Creek in Craven and Pamlico Counties" dated December 11, 2002 and revised on January 24, 2003 and August 29, 2003. The permittee must submit the revised mitigation plan to DCM for approval, and receive approval from DCM, prior to initiating any construction on TIP No. R-2539B. The revised mitigation plan shall include the following at a minimum:
- Identification of reference wetlands that are riverine wetlands subject to frequent flooding or inundation.
 - A commitment to conduct an annual detailed comparison of the wetland restoration and enhancement areas to reference wetlands for a period of five years or until vegetative and hydrologic success is documented and approved by DCM, DWQ and USACE. This comparison will include an annual tree count within the wetland restoration areas that are not underneath the new bridges.
 - Incorporation of the requirement in Condition No. 16 of this CAMA permit, and Condition No. 19 of the original CAMA permit.
- 22) This permit does not convey or imply approval of the suitability of any excess mitigation generated by TIP No. R-2539 as compensatory wetland mitigation for any particular future projects. The use of any excess mitigation generated by TIP No. R-2539 as compensatory mitigation for future projects will be approved on a case-by-case basis during the CAMA permit review and/or consistency process.
- 23) If the excess mitigation generated by TIP No. R-2539 is to be used as mitigation for impacts of future projects, written concurrence must be obtained from DCM. Any vegetative and hydrologic monitoring data that is available when the site is proposed for use as mitigation for future projects shall be made available to DCM.

General

- 24) All pipe and culvert inverts will be buried at least one foot below normal bed elevation to allow for passage of water and aquatic life when they are placed within the Public Trust Area of Environmental Concern (AEC) and/or the Estuarine Waters AEC as designated by CAMA, and/or all streams appearing as blue lines on United States Geological Survey (USGS) quad sheets.
- 25) Any relocation of utility lines that is not already depicted on the attached workplan drawings, or described within the attached permit application, will require additional authorization, either by way of a modification of this permit or by the utility company obtaining separate authorization.

ADDITIONAL CONDITIONS

- 26) The N.C. Division of Water Quality has authorized the proposed project under a modification to Water Quality Certification No. 3415 (DWQ Project No. 021232). The modification was issued on 10/27/03. Any violation of the Certification approved by DWQ will be considered a violation of this CAMA permit.
- 27) This major modification must be attached to the original of Permit No. 55-03, which was issued on 4/22/03, and both documents must be readily available on site when a Division representative inspects the project for compliance.
- 28) All conditions and stipulations of the active permit remain in force under this major modification unless altered herein.

NOTE: The U.S. Army Corps of Engineers has assigned the proposed project COE Action ID. No. 199303531.

NOTE: This permit does not eliminate the need to obtain any additional state, federal or local permits, approvals or authorizations that may be required.



STATE OF NORTH CAROLINA
DEPARTMENT OF TRANSPORTATION

MICHAEL F. EASLEY
GOVERNOR

LYNDO TIPPETT
SECRETARY

October 29, 2003

TO: Cathy Brittingham, DCM

FROM: Elizabeth L. Lusk, Environmental Supervisor, O.N.E., PDEA *Elizabeth*

SUBJECT: R-2539B revised permit drawings and summary, sheets 19 and 39 of 40

Please find attached revised permit drawing sheets. These revisions were required in order to prevent hydrologic trespass for a property owner north of NC 55 (property number 18). Two new pre-formed scour holes have been installed to receive additional drainage. Mechanized clearing impacts have increased slightly from 0.44 acres to 0.52 acres. Additional mechanized clearing is required around the two newly placed pre-formed scour holes on the north side at Station No. 113+50.

Please do not hesitate to contact me at (919) 715-1444, if there are further questions.

File: R-2539B

RECEIVED
OCT 29 2003
DIV. OF COASTAL MANAGEMENT
RALEIGH

MAILING ADDRESS:
NC DEPARTMENT OF TRANSPORTATION
PROJECT DEVELOPMENT AND ENVIRONMENTAL ANALYSIS
1598 MAIL SERVICE CENTER
RALEIGH NC 27699-1598

TELEPHONE: 919-715-1500
FAX: 919-715-1501
WEBSITE: WWW.DOH.DOT.STATE.NC.US

LOCATION:
2728 CAPITOL BOULEVARD
PARKER LINCOLN BUILDING, SUITE 168
RALEIGH NC 27699



STATE OF NORTH CAROLINA
DEPARTMENT OF TRANSPORTATION

MICHAEL F. EASLEY
GOVERNOR

LYNDO TIPPETT
SECRETARY

July 21, 2003

Division of Coastal Management
North Carolina Department of Environment And Natural Resources
151-B Hwy. 24, Hestron Plaza II
Morehead City, NC 28557

JUL 24 2003

ATTN.: Mr. Bill Arrington
Transportation Projects

Dear Sir:

Subject: **Application for Division of Coastal Management Modification of the Major Development Permit No. 55-03 for TIP No. R-2539.** NC 55 Widening From US 17 in Bridgeton to NC 304 in Bayboro, Craven and Pamlico Counties, NCDOT Division No. 2. Federal Aid Project STP-55(1). State Project No. 8.1170901. WBS Element No. 34452.1.1. USACE Action ID 199303531. DWQ Project No. 021232, WQC No. 3415.

The North Carolina Department of Transportation (NCDOT), Division of Highways, is requesting a permit modification for the above referenced project. On April 22, 2003 the CAMA Major Development Permit No. 55-03 was issued for the widening of NC 55 from US 17 to NC 304 in Bayboro. The Permit approved the CAMA jurisdictional impacts associated with Section A of the project and requested that modification of the Permit be made for Sections B and C as the final design drawings and jurisdictional impact assessments for those sections were completed. The purpose of this letter is to request a modification to the CAMA Major Development Permit No. 55-03 for approval of impacts associated with Section B of the project. The final permit drawings and relevant information for R-2539B are attached. Another modification request will be submitted for Section C when the design for it is completed.

The completed design for R-2539B does not compromise NCDOT's compliance with the existing permit conditions. No additional mitigation is proposed. The completed design has been evaluated for compliance with the avoidance/minimization criteria and is in compliance with all previous Individual Permit factors, including the following:

- Protected Species,
- Cultural Resources,
- Aquatic Life passage,
- FEMA compliance, and
- Utilities.

Much of the general information in the original Individual Permit application remains the same and is not repeated in this modification request. Information on the purpose and need, project schedule, NEPA document status, and mitigation options is contained in the original permit application.

MAILING ADDRESS:
NC DEPARTMENT OF TRANSPORTATION
PROJECT DEVELOPMENT AND ENVIRONMENTAL ANALYSIS
1598 MAIL SERVICE CENTER
RALEIGH NC 27699-1598

TELEPHONE: 919-715-1500
FAX: 919-715-1501

WEBSITE: WWW.DOH.DOT.STATE.NC.US

LOCATION:
2728 CAPITOL BOULEVARD
PARKER LINCOLN BUILDING, SUITE 168
RALEIGH NC 27699

Summary of Project Impacts: In the August 9, 2002 application, total impacts to CAMA jurisdictional Areas of Environmental Concern (AECs) were estimated to be 118.1 linear feet at a UT to West Fork Goose Creek in Section B. Impacts to 404 jurisdictional areas of the entire R-2539 were estimated at 15.69 acres of permanent wetland, 0.15 acres of fill in surface waters, and 619 linear feet of stream channels. With the revised impacts associated with the final design of Section B, the total project impacts (all three Sections) are now estimated to be 15.74 acres of wetland impacts, 0.15 acres of fill in surface waters, and 619 linear feet of stream channels. The minor differences in impacts are from wetland drainage impacts in the final design of Section B, minor changes in the impact area calculations (rounding), and extension of buffer impact calculations out to the edge of drainage easements rather than limiting calculations to the toe of fill slope.

Permanent impacts associated with the final design of Section B consist of 3.69 acres of 404 jurisdictional wetland impacts and 295 linear feet of stream channel impacts (Tables 1 and 2). Of these 295 feet, 118.1 feet of impacts will be to the UT to West Fork Goose Creek AEC (Site 13). Temporary impacts consist of less than 0.01 acres of fill for the temporary work bridges at Site 4. The riverine (Sites 4 and 16) and non-riverine wetland impacts include 0.65 acres and 2.98 acres, respectively. Fill in wetlands totals 1.87 acres, mechanized clearing totals 1.51 acres, and excavation in wetlands totals 0.25 acres of the total wetland impacts in Section B. Drainage impacts in Section B total 0.06 acres of non-riverine wetlands.

Design Changes: Final design revision resulted in two sites differing from those submitted with the original permit application.

Site 1, Permit Sheet 7 of 40

Station 56+30 left

Because of the low grade and minimal drainage potential of the natural ground elevation at this site, it will be necessary to install a typical V-ditch with 6:1 side slopes to drain the subgrade of the new road. Based on the Boussinesq equation calculations, there will be additional impacts resulting from the drainage impact from this ditch. The Ditch Impact Study, dated July 2003, is attached.

Impact change: increase of 0.06 acres of non-riverine wetland impacts

Site 2, Permit sheet 8 of 40

Station 59+80 left

Drainage effects from the wetland ditch feeding into the pre-formed scour hole were not calculated because this ditch will bring water into the wetland, contributing to the hydrology rather than diminishing it.

Impact change: no change to jurisdictional impacts

Site 4, Permit sheet 10 of 40

Station 77 +00 to 77+20, left

At this site an area of mechanized clearing in wetlands has been changed to excavation to accommodate a drainage swale.

Impact change: no change to jurisdictional impacts

Table 1. Jurisdictional Wetland and Surface Water Impacts on R-2539B

Site	Station From/To	Fill in Wetland (ac)	Excavation in Wetlands (ac)	Mechanized Clearing (ac) (Method III) ²	Drainage Impacts (ac)
1	56 +30/56 +55		0.08	0.02	0.06 (+0.06)
2	59 +70/61 +00	0.13	0.03	0.05	
3	62 +25/63 +60	0.14		0.02	
4 ¹	74 +85/82 +00	0.34	0.01 (+0.01)	0.14 (-0.01)	
5	81 +85/82 +00	0.03		0.01	
6	102 +35/103 +65	0.12		0.09	
7	108 +50/114 +00	0.71		0.44	
8	117 +20/118 +60	0.02		0.09	
9	119 +20/120 +20	0.05		0.06	
10	121 +70/122 +20	0.11		0.03	
11	123 +75/125 +60	0.05		0.04	
12	130 +60/131 +95	Impacts avoided		Impacts avoided	
13	134 +75/137 +30	0.07	0.12	0.33	
14	139 +10/139 +20	0.04	<0.01	0.01	
15	145 +35/146 +75			0.09	
16 ¹	148 +10/151 +40	0.07		0.08	
TOTAL R-2539B		1.87 (-0.01)³	0.25 (+0.01)	1.51 (-0.01)	0.06 (+0.06)

¹ Sites 4 and 16 contain riverine wetlands associated with Deep Run and Goose Creek.

² Clearing and grubbing of vegetation to 10 feet beyond the construction limits.

³ Impact increase or decrease from original IP application is denoted in parentheses.

Table 2. Jurisdictional Stream Information, Sections R-2539B

Site	Station Number (From/To)	Structure	Stream Name	DWQ Index No.	DWQ Rating	Status	Impact (ft)	Onsite Stream Relocation (ft)	Required Mitigation 2:1 (ft)
2	59+70/61+00	1650 RCP	Sassers Branch	27-106-5	SC Sw NSW	P	72.2	0	144.4
4	74+85/77+40	Bridge 328 feet	Deep Run Creek	27-106-6	SC Sw NSW	P	0	0	0
5	81+85/82+00	1050 RCP	UT to Deep Run	27-106-6	SC Sw NSW	I	52.5	0	105
7	108+50/114+00	1.8x1.2 RCBC	UT to Black Creek	27-107-7	SC Sw NSW	I	52.5	0	72.2 ²
13	134+75/137+30	900 RCP	UT to West Fork Goose Creek	27-107-2	C Sw NSW	P	118.1	134.5	0
16	148+10/151+40	Bridge 732 feet	Goose Creek	27-107-(1)	C Sw NSW	P	0	0	0
TOTAL R-2539B							295.2 (-0.1)	134.5	321.6

¹ Impact increase or decrease from original IP application is denoted in parentheses.

² NCDOT proposes that the relocated stream channel at Site 13 will provide onsite mitigation for Site 13 impacts as well as 16 feet of Site 7 impacts, requiring the balance of 36 feet of impact from Site 7 to be mitigated for offsite at a ratio of 2:1.

Summary of Utility Impacts for Section B (permit drawings attached): It will be necessary to relocate several utilities because of road widening activities. No additional 404 jurisdictional impacts will be incurred. Any clearing required will be conducted by hand. Cleared vegetation will remain onsite. Directional boring will be utilized when necessary.

For overhead power lines, utility poles will be relocated to one foot outside the new proposed Right-of-Way lines. At the staged construction of the bridges over Deep Run Creek and Goose Creek, the power will be temporarily relocated to the north side of NC 55 during construction of the southern portion of the structures and then return to the existing alignment after construction. Any clearing for the relocation of overhead power lines within jurisdictional areas will be done by hand.

Underground copper and fiber optic telephone lines in the shoulders of the existing roadway will be relocated to the proposed shoulder or to the edge of the proposed cut or fill slopes. Wetlands and buffer zones will be directionally bored with conduit to avoid jurisdictional impacts. The water line along the length of the project will be relocated within the permitted footprint of the roadway work. Stream and wetland crossings will be directional bored to avoid surface impacts. There is an existing sewer line along the project from Bennett Tingle Road to the eastern project limits. Prior to installation, the sewer design was coordinated with NCDOT and should not require replacement. If any relocation is needed, it will be done by a private contractor within the footprint of the roadway project. No additional impacts to jurisdictional areas will be incurred.

Indirect and Cumulative Impacts: The Indirect and Cumulative Impact Study (attached) for R-2539B indicates that development is expected to continue in the study area and along the NC 55 corridor. The non-residential development along NC 55 will be dependent on population growth and, to a lesser extent, influenced by the widening of the highway. Existing policies and regulations will manage potential indirect impacts to the area's water quality. The construction of R-2539B is not expected to result in any indirect or cumulative impacts that will adversely affect water quality.

Summary of Mitigation: Throughout NEPA and design process this project has been designed to avoid and minimize impacts to jurisdictional areas. Specific strategies, detailed in the original application, remain valid for this application. Highlights include widening NC 55 along the existing roadway, using 3:1 slopes within wetland limits, extending bridge spans at Deep Run Creek and Goose Creek, natural stream design for the relocated stream at Site 13, and wetland restoration associated with the removal of existing bridge causeways and an abandoned railroad bed. Offsite Mitigation for the remaining impacts will still be covered by the Croatan and Brock Mitigation Sites as described in the original permit application.

Application is hereby made for a major modification of the Division of Coastal Management CAMA Permit as required for the above-described activities.

If you have any questions or need additional information, please call Ms. Elizabeth Lusk (919) 715-1444

Sincerely,

JUL 24 2003

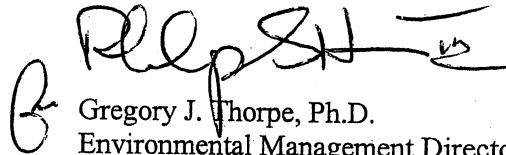

Gregory J. Thorpe, Ph.D.
Environmental Management Director, PDEA

Attachments:

Permit Drawings and Half-size plans
Utility Drawings
Indirect and Cumulative Impact Study
Ditch Impact Study, July 2003

CC: Ms. Cathy Brittingham, NCDCM
M. David Franklin, USACE, Wilmington (Cover Letter Only)
Mr. Mike Bell, NCDOT Coordinator, USACE, Washington
Mr. John Dorney, DWQ, Raleigh
Mr. Jay Bennett, P. E., Roadway Design
Mr. Omar Sultan, Programming and TIP
Ms. Debbie Barbour, P. E., Highway Design
Mr. David Chang, P. E., Hydraulics
Mr. Greg Perfetti, P. E., Structure Design
Mr. Mark Staley, Roadside Environmental
Mr. Jay Johnson, Division 2 Environmental Officer
Ms. Colista Freeman, P. E., NCDOT Project Development and Environmental Analysis
Mr. C. E Lassiter, Jr., P. E. Division 2 Engineer, Greenville

APPLICATION

(To be completed by all applicants)

1. APPLICANT R-2539B

a. Landowner:

Name N.C. Department of Transportation

Address 1548 Mail Service Center

City Raleigh State NC

Zip 27699-1548 Day Phone 919-733-3141

Fax (919) 733-9794

b. Authorized Agent:

Name: _____

Address: _____

City: _____ State: _____

Zip: _____ Day Phone: _____

Fax: _____

c. Project name (if any): T.I.P. R-2539B,
State Project No. 8.1170901, NC 55 Widening

NOTE: *Permit will be issued in name of landowner(s), and/or project name.*

2. LOCATION OF PROPOSED PROJECT

a. County: Pamlico

b. City, town, community or landmark:

Reelsboro; from east of SR 1127 to SR 1129 in Pamlico County

c. Street address or secondary road number:

NC 55

d. Is proposed work within city limits or planning jurisdiction? Yes No

e. Name of body of water nearest project (e.g. river, creek, sound, bay): Sassers Branch, Deep Run Creek, Black Creek, Goose Creek

3. DESCRIPTION AND PLANNED USE OF PROPOSED PROJECT

a. List all development activities you propose (e.g. building a home, motel, marina, bulkhead, pier, and excavation and/or filling activities).
Roadway widening and bridge construction.

b. Is the proposed activity maintenance of an existing project, new work, or both? NEW

c. Will the project be for public, private or commercial use? Public

d. Give a brief description of purpose, use, methods of construction and daily operations of proposed project. If more space is needed, please attach additional pages. Widening of NC 55 from two to five lanes, from east of SR 1127 to SR 1129 in Pamlico County.

Highway construction equipment

JUL 24 2003

4. LAND AND WATER CHARACTERISTICS

- a. Size of entire tract: 74 acres
- b. Size of individual lot(s): N/A
- c. Approximate elevation of tract above MHW or NWL: ±/- 10 feet
- d. Soil type(s) and texture(s) of tract: See original permit
- e. Vegetation on tract See original permit cover letter
- f. Man-made features now on tract Bridge, roadway
- g. What is the CAMA Land Use Plan land classification of the site? (Consult the local land use plan.)
Craven County = C, Pamlico County = P
 Conservation C Transitional
P Developed P Community
P Rural Other
- h. How is the tract zoned by local government?
- i. Is the proposed project consistent with the applicable zoning? X Yes No
(Attach zoning compliance certificate, if applicable)
- j. Has a professional archaeological assessment been done for the tract? X Yes No
If yes, by whom? NC DOT and SHPO
- k. Is the project located in a National Registered Historic District or does it involve a National Register listed or eligible property?
X Yes No
- l. Are there wetlands on the site? X Yes No
Coastal (marsh) Other
If yes, has a delineation been conducted? Yes,
Michael F. Bell, USCOE, Sept. 1, 2001
(Attach documentation, if available)
- m. Describe existing wastewater treatment facilities.
None

- n. Describe location and type of discharges to water of the state. (For example, surface runoff sanitary wastewater, industrial/commercial effluent, "wash down" and residential discharges.) Surface runoff from roadway
- o. Describe existing drinking water supply source.
County water line

5. ADDITIONAL INFORMATION

In addition to the completed application form, the following items must be submitted:

- A copy of the deed (with state application only) or other instrument under which the applicant claims title to the affected properties. If the applicant is not claiming to be the owner of said property, then forward a copy of the deed or other instrument under which the owner claims title, plus written permission from the owner to carry out the project.
- An accurate, dated work plat (including plan view and cross-sectional drawings) drawn to scale in black ink on an 8 1/2" by 11" white paper. (Refer to Coastal Resources Commission Rule 7J.0203 for a detailed description.)

Please note that original drawings are preferred and only high quality copies will be accepted. Blue-line prints or other larger plats are acceptable only if an adequate number of quality copies are provided by applicant. (Contact the U.S. Army Corps of Engineers regarding that agency's use of larger drawings.) A site or location map is a part of plat requirements and it must be sufficiently detailed to guide agency personnel unfamiliar with the area to the site. Include highway or secondary road (SR) numbers, landmarks, and the like.
- A Stormwater Certification, if one is necessary.
SW7020722 issued 10/7/02
- A list of the names and complete addresses of the adjacent waterfront (riparian) landowners and signed return receipts as proof that such owners have received a copy of the application and plats by certified mail. Such landowners must be advised that they have 30 days in which to submit comments on the

proposed project to the Division of Coastal Management. Upon signing this form, the applicant further certifies that such notice has been provided.

See Attached permit drawings

Name _____
Address _____
Phone _____

Name _____
Address _____
Phone _____

Name _____
Address _____
Phone _____

- A list of previous state or federal permits issued for work on the project tract. Include permit numbers, permittee, and issuing dates.

- A check for \$400 made payable to the Department of Environment, Health, and Natural Resources (DEHNR) to cover the costs of processing the application.

- A signed AEC hazard notice for projects in oceanfront and inlet areas.

- A statement of compliance with the N.C. Environmental Policy Act (N.C.G.S. 113A - 1 to 10) If the project involves the expenditure of public funds or use of public lands, attach a statement documenting compliance with the North Carolina Environmental Policy Act.

6. CERTIFICATION AND PERMISSION TO ENTER ON LAND

I understand that any permit issued in response to this application will allow only the development described in the application. The project will be subject to conditions and restrictions contained in the permit.

I certify that to the best of my knowledge, the proposed activity complies with the State of North Carolina's approved Coastal Management Program and will be conducted in a manner consistent with such program.

I certify that I am authorized to grant, and do in fact, grant permission to representatives of state and federal review agencies to enter on the aforementioned lands in connection with evaluating information related to this permit application and follow-up monitoring of the project.

I further certify that the information provided in this application is truthful to the best of my knowledge.

This is the 29 day of August, ~~19~~ 2003

Print Name Gordon Cashin

Signature Gordon E Cashin for
Landowner or Authorized Agent Philip S. Heron

Please indicate attachments pertaining to your proposed project.

- DCM MP-2 Excavation and Fill Information
- DCM MP-3 Upland Development
- DCM MP-4 Structures Information
- DCM MP-5 Bridges and Culverts
- DCM MP-6 Marina Development

NOTE: Please sign and date each attachment in the space provided at the bottom of each form.

BRIDGES AND CULVERTS

JUL 24 2003

Attach this form to Joint Application for CAMA Major Permit, Form DCM-MP-1. Be sure to complete all other sections of the Joint Application that relate to this proposed project.

g. Length of proposed bridges a) 328 ft b) 732 ft

h. Width of proposed bridges a) 67 ft b) 70 ft

i. Height of proposed bridges above wetlands a) 13 ft b) 12 ft

j. Will the proposed bridges affect existing water flow? Yes No ?
If yes, explain _____

k. Navigation clearance underneath proposed bridges a) 6 ft b) 9 ft ?

l. Will the proposed bridge affect navigation by reducing or increasing the existing navigable opening? Yes No
If yes, explain _____

m. Will the proposed bridge cross wetlands containing no navigable waters? Yes No
If yes, explain : The existing causeway fills will be removed and the new bridges will be constructed over existing and restored wetlands.

n. Have you contacted the U.S. Coast Guard concerning their approval? Yes No
If yes, please provide record of their action.

1. BRIDGES R-2539 B

a. Public Private _____

b. Type of bridge (construction material)
two bridges utilizing 36" ppc girders

c. Water body to be crossed by bridges
a) Deep Run Creek and b) Goose Creek

d. Water depth at the proposed crossings at MLW or NWL a) 3ft b) 3.5 ft

e. Will proposed bridge replace an existing bridge?
 Yes No

If yes,

(1) Length of existing bridges a) 70 ft b) 100 ft

(2) Width of existing bridges a) 26 ft b) 26 ft

(3) Navigation clearance underneath existing bridges a) 6 ft b) 9 ft

(4) Will all, or a part of, the existing bridges be removed? (Explain) Yes, the existing bridges and causeways fill will be removed as the new bridges is built.

f. Will proposed bridges replace an existing culvert(s)?
Yes No

If yes,

(1) Length of existing culvert _____

(2) Width of existing culvert _____

(3) Height of the top of the existing culvert above the MHW or NWL _____

(4) Will all, or a part of, the existing culvert be removed? (Explain) _____

2. CULVERTS

a. Water body in which culvert is to be placed
Sassers Branch, UT to Deep Run Creek, UT to Black Creek,

b. Number of culverts proposed 5

c. Type of culvert (construction material, style)
concrete pipe, concrete box culvert

d. Will proposed culverts replace an existing bridge?

Yes No

If yes,

- (1) Length of existing bridge _____
- (2) Width of existing bridge _____
- (3) Navigation clearance underneath existing bridge _____
- (4) Will all, or a part of, the existing bridge be removed? (Explain) _____

e. Will proposed culverts replace an existing culvert? Yes No

If yes, See attached Table MP5-2e

- (1) Length of existing culvert _____
- (2) Width of existing culvert _____
- (3) Height of the top of the existing culvert above the MHW or NWL +/- 2' _____
- (4) Will all, or a part of, the existing culvert be removed? (Explain) No, culverts will be extended

f. Length of proposed culvert See Table MP5-2e

g. Width of proposed culvert Same as existing

h. Height of the top of the proposed culvert above the MHW or NWL +/- 2' _____

i. Will the proposed culvert affect existing water flow? Yes No

If yes, explain _____

j. Will the proposed culvert affect existing navigation potential? Yes No

If yes, explain _____

b. Will the placement of the proposed bridge or culvert require any excavation within: Coastal Wetlands SAVs Other Wetlands

If yes, See Attached Permit Drawings

- (1) Length of area to be excavated _____
- (2) Width of area to be excavated _____
- (3) Amount of material to be excavated in cubic yards _____

c. Will the placement of the proposed bridge or culvert require any highground excavation? Yes No

If yes, See Attached Permit Drawings

- (1) Length of area to be excavated _____
- (2) Width of area to be excavated _____
- (3) Amount of material to be excavated in cubic yards _____

d. If the placement of the bridge or culvert involves any excavation, please complete the following:

- (1) Location of the spoil disposal area Approved upland disposal site.
- (2) Dimensions of spoil disposal area Unknown at this time
- (3) Do you claim title to the disposal area? Yes No
If no, attach a letter granting permission from the owner.
- (4) Will the disposal area be available for future maintenance? Yes No
- (5) Does the disposal area include any coastal wetlands (marsh), SAVs, or other wetlands? Yes No
If yes, give dimensions if different from (2) above. _____
- (6) Does the disposal area include any area below the MHW or NWL? Yes No
If yes, give dimension if different from No. 2 above. _____

3. EXCAVATION AND FILL

a. Will the placement of the proposed bridge or culvert require any excavation below the MHW or NWL? Yes No

See Attached Permit Drawings

If yes,

- (1) Length of area to be excavated _____
- (2) Width of area to be excavated _____
- (3) Depth of area to be excavated _____
- (4) Amount of material to be excavated in cubic yards _____

e. Will the placement of the proposed bridge or culvert result in any fill (other than excavated material described in Item d. above) to be placed below MHW or NWL? Yes No

If yes,

- (1) Length of area to be filled _____
- (2) Width of area to be filled _____
- (3) Purpose of fill _____

f. Will the placement of the proposed bridge or culvert result in any fill (other than excavated material described in Item d. above) to be placed within:

DCM MP5

Culverts

Table MP5-2e. Culverts

Station Number	Water Body	Existing Culvert	Proposed Culvert	Height Above MHW or NWL
A 12+00	UT to Duck Creek	53" x 62' RCP	53" x 131' RCP	2'
B 60+12.4	Sasser's Branch	2 lines of 64" x 65' RCP	2 lines of 65" x 120' RCP	4'
B 82+00	UT to Deep Run Creek	42" x 20' RCP	42" x 105' RCP	
B 112+81.3	UT to Black Creek	48"x70" and 48"x48" x 62' RCBC	48"x70" and 48"x48" x 117' RCBC	3'
B 136+71.8	UT to Goose Creek	70"x48' x 70' RCBC	70"x48' x 103' RCBC	3.6'
B 139+00	UT to Goose Creek	36" x 82' RCP	36" x 118' RCP	

Subject: R-2539B additional mitigation**Date:** Tue, 19 Aug 2003 16:44:39 -0400**From:** Elizabeth Lee Lusk <ellusk@dot.state.nc.us>**Organization:** North Carolina Department of Transportation**To:** "Agency COE (Wash.)- Mike Bell" <Michael.F.Bell@usace.army.mil>,
"Agency DCM (Bill Arrington)" <bill.arrington@ncmail.net>,
"Agency DCM (Cathy Brittingham)" <Cathy.Brittingham@ncmail.net>,
Agency DWQ - John Hennessy <John.Hennessy@ncmail.net>**CC:** "Agency FWS (1-8) - Gary Jordan" <gary_jordan@fws.gov>,
"Agency NCWRC - Travis Wilson (Div. 1-8)" <travis.wilson@ncwildlife.org>

Per earlier conversations today with Mike Bell (both issues) and John Hennessy (the latter issue), I submit the following minor revisions to NCDOT's application for a modification to the R-2539 permits/certifications.

Compensatory Mitigation

- In the original May 2003 permit, the NCDOT estimated non-riverine wetland impacts to be 14.30 acres for the entire project. As compensatory mitigation, 28.60 acres of non-riverine wetland mitigation were provided at the Croatan MBI.

- The July 21, 2003 permit modification request, which was based on final design for Section B, revealed a shortfall of 0.05 acres of non-riverine wetland impacts. In order to mitigate for these additional impacts, the NCDOT will reserve an additional 0.1 acres of non-riverine wetlands from the Croatan MBI.

- Therefore, total non-riverine wetland impacts for the entire project will be 14.35 acres, requiring total compensatory mitigation from the Croatan MBI of 28.70.

Restoration Plan for onsite mitigation

The current Restoration Plan designates onsite wetland restoration by removal of the existing bridge causeways and portions of the adjacent railroad bed. It further stipulates *"The existing causeways will be removed and graded down approximately three feet below the grade of the surrounding wetlands. The excavated areas will be back filled with undercut material (muck) removed during the construction of R-2539"*. This has become a water quality and constructability issue. The resulting 3-foot deep pit would be difficult to backfill without causing significant water quality problems and the need for hydrated muck would create a considerable construction phasing challenge. Per the referenced conversations, I have attached a revised Restoration Plan. I understand that this revision will require permit modifications. Therefore, I will be submitting a separate modification request. In the meantime, I wanted to give everyone a heads up that this request is coming.

Please do not hesitate to call with questions or comments.

Elizabeth

 Restoration Plan.doc	<p>Name: Restoration Plan.doc Type: WINWORD File (application/msword) Encoding: base64 Download Status: Not downloaded with message</p>
--	--

Elizabeth Lee Lusk <ellusk@dot.state.nc.us>
Environmental Supervisor
Project Development & Environmental Analysis



STATE OF NORTH CAROLINA
DEPARTMENT OF TRANSPORTATION

MICHAEL F. EASLEY

LYNDO TIPPETT

GOVERNOR

SECRETARY

Facsimile

To: Mike Bell, USACE, Washington From: Elizabeth L. Lusk,
Cathy Brittingham, DCM Raleigh Office of Natural Environment
Bill Arrington, DCM, Morehead City
John Hennessy, DWQ, Raleigh

Fax: (252) 975-1399 Phone: 715-1444
733-1495
(252) 247-3330
733-6893

Phone: (252) 975-1616 x26 Pages: 3
733-2293 x238
252-808-2808
733-5694

Re: R-2539 revised onsite mitigation Date: 10/22/03

Urgent For Review Please Comment Please Reply Please Recycle

Find attached a memo revising the onsite riverine mitigation acreages for Sections A and B of the NC 55 road widening project in Craven and Pamlico Counties. Revised plan sheets depicting ROW extensions around the mitigation sites are forthcoming next week.

Thanks. *Elizabeth*



STATE OF NORTH CAROLINA
DEPARTMENT OF TRANSPORTATION

MICHAEL F. EASLEY
GOVERNOR

LYNDO TIPPETT
SECRETARY

October 22, 2003

TO: Cathy Brittingham, DCM
Mike Bell, USACE
John Hennessy, DWQ

FROM: Elizabeth L. Lusk, Environmental Supervisor, O.N.E., PDEA *Elizabeth*

SUBJECT: NC 55 Widening in Craven and Pamlico Counties, TIP No. R-2539,
Revised acreages for onsite riverine mitigation at Upper Broad Creek,
Deep Run Creek, and Goose Creek

The NCDOT has revised the mitigation acreages for onsite mitigation. The original wetland restoration acreages were calculated using Microstation and are exact. However, the original wetland enhancement acreages were calculated by hand. These revised enhancement acreages are the result of more precise Microstation calculations.

Wetland enhancement is a result of lifting causeways. In order to quantify the extent of the enhancement, the "Cox semi-circle" method was employed. The area of enhancement was calculated as a $\frac{1}{4}$ circle, the radius of which is the length of the causeway to be removed. In the cases where riprap will be placed within the area of causeway removed, the radius of the $\frac{1}{4}$ circle was shortened by the length of the area covered by riprap. The center of the $\frac{1}{4}$ circle is at the point where the causeway to be removed meets the upland area. The $\frac{1}{4}$ circle was calculated separately for each quadrant of the causeway. Open water was not included in the enhancement area. The following table breaks down the acreages by project section, permit drawing site, wetland mitigation type, and mitigation per water body.

MAILING ADDRESS:
NC DEPARTMENT OF TRANSPORTATION
PROJECT DEVELOPMENT AND ENVIRONMENTAL ANALYSIS
1598 MAIL SERVICE CENTER
RALEIGH NC 27699-1598

TELEPHONE: 919-715-1500
FAX: 919-715-1501

WEBSITE: WWW.DOH.DOT.STATE.NC.US

LOCATION:
2728 CAPITOL BOULEVARD
PARKER LINCOLN BUILDING, SUITE 168
RALEIGH NC 27699

Onsite Riverine Wetland Mitigation for R-2539

Section Site No.	Station No.	Water Body	Restoration	Enhancement (ac)				Total area
			Total area (ac)	NW Quadrant	SW Quadrant	NE Quadrant	SE Quadrant	
A 11 & 12	-L- 41+50	Upper Broad	1.78	0.69	1.31	0.45	0.71	3.16
B 4	-L- 76+25	Deep Run	0.58	0.59	0.70	0.10	0.11	1.50
B 16	-L- 149+40	Goose Creek	1.87	0.94	0.81	2.65	2.93	7.33
Totals			4.23					11.99

The NCDOT proposes to use part of the onsite riverine wetland restoration to mitigate for all riverine wetland impacts (1.39 acres) on Sections A and B. We anticipate a surplus of 2.84 acres of restoration and the entire 11.99 acres of enhancement and respectfully request to bank the remaining credits for offsite riverine wetland impacts.

Revised plan sheets depicting the additional ROW preserving the enhancement areas will be forwarded as soon as they are available. In the interim, please do not hesitate to contact me at (919) 715-1444, if there are questions.

File: R-2539

Page 2 of 10-22-03 memo.

Post-it® Fax Note	7671	Date	10-23-03	# of pages	1
To	Cathy Brittingham		From	Elizabeth	
Co./Dept.			Co.		
Phone #			Phone #	715-1444	
Fax #	733-1495		Fax #		

TECHNICAL MEMORANDUM
DITCH IMPACT STUDY
NC-55
PAMLICO COUNTY, NORTH CAROLINA
TRAFFIC IMPROVEMENT PROJECT (TIP) NO. R-2539B



NORTH CAROLINA DEPARTMENT OF TRANSPORTATION
PROJECT DEVELOPMENT AND ENVIRONMENTAL ANALYSIS BRANCH
RALEIGH, NORTH CAROLINA

JULY 2003

TABLE OF CONTENTS

1.0 INTRODUCTION	1
2.0 METHODS	3
Model Descriptions	3
Model Application.....	3
3.0 RESULTS and CONCLUSIONS	4
4.0 REFERENCES	11

LIST OF FIGURES

Figure 1. Site Location	2
Figure 2. Proposed Impact of Project Ditch on Adjacent Wetlands.....	8

LIST OF TABLES

Table 1. Boussinesq Equation Variables and Results	5
Table 2. Drainmod Input/Output for Project Ditch.....	6
Table 3. Drainmod Input/Output for Project Ditch.....	7

TECHNICAL MEMORANDUM

DITCH IMPACT STUDY NC-55 WIDENING (R-2539B) PAMLICO COUNTY, NORTH CAROLINA

1.0 INTRODUCTION

The North Carolina Department of Transportation (NCDOT) is proposing to widen North Carolina State Highway 55 (NC-55) into a multilane facility in Craven and Pamlico Counties, North Carolina. The improvements to NC-55 are anticipated to occur from US-17 at Bridgeton to NC-304 in Bayboro, North Carolina. The total length of the R-2539 project extends 10.2 miles, broken into several segments. The current study, which is focused on a small portion of segment B near the Town of Olympia, has been undertaken to evaluate the drainage impact to wetlands that a single, special¹ ditch (hereafter referred to as the "project ditch") will create when dug adjacent to the proposed, widened facility. The project ditch occurs at the western terminus of the "B" section for the NC-55 improvement (TIP R-2539B). The results of this modeling effort will be used to determine the amount of wetlands that will be permanently impacted by the project ditch through impacts to the wetland hydroperiod. This impact will be considered cumulative with other filling, excavation, and mechanized clearing activities within jurisdictional areas and is expected to be considered in the Section 404 and Section 401 permit applications. EcoScience Corporation (ESC) has been retained to estimate the drainage influence of the project ditch, as well as determine the amount of jurisdictional wetlands that will be impacted due to this drainage influence. The station number, location and details of the ditch were provided by NCDOT to ESC personnel. The drainage impacts estimated by ESC will be interpreted by NCDOT and included in the Section 404 permit application.

Specifically, the goal of this study is to compare the output of two mathematical models to estimate the linear distance from the edge of the project ditch where the potential exists for drainage impacts to occur within jurisdictional wetlands. As requested by NCDOT, the Boussinesq Equation was used to estimate the area of drainage impacts associated with the project ditch, and then compared to results generated by the hydraulic model DRAINMOD. Subsequently, the acreage of wetlands potentially drained due to the influence of the ditch can be mapped by NCDOT personnel and accounted for in the permit application in addition to filling, excavation, and clearing acreages.

This document provides a summary of the methods used and results in applying the Boussinesq Equation and DRAINMOD computer simulation to the proposed NCDOT ditching activities.

¹Special ditches generally parallel the road corridor and are designed to induce a groundwater withdrawal gradient within adjacent fill material. The withdrawal gradient is intended to protect the roadway's substrate from underlying water.

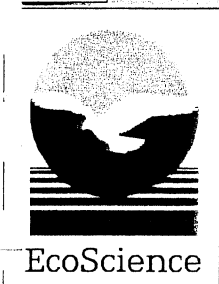
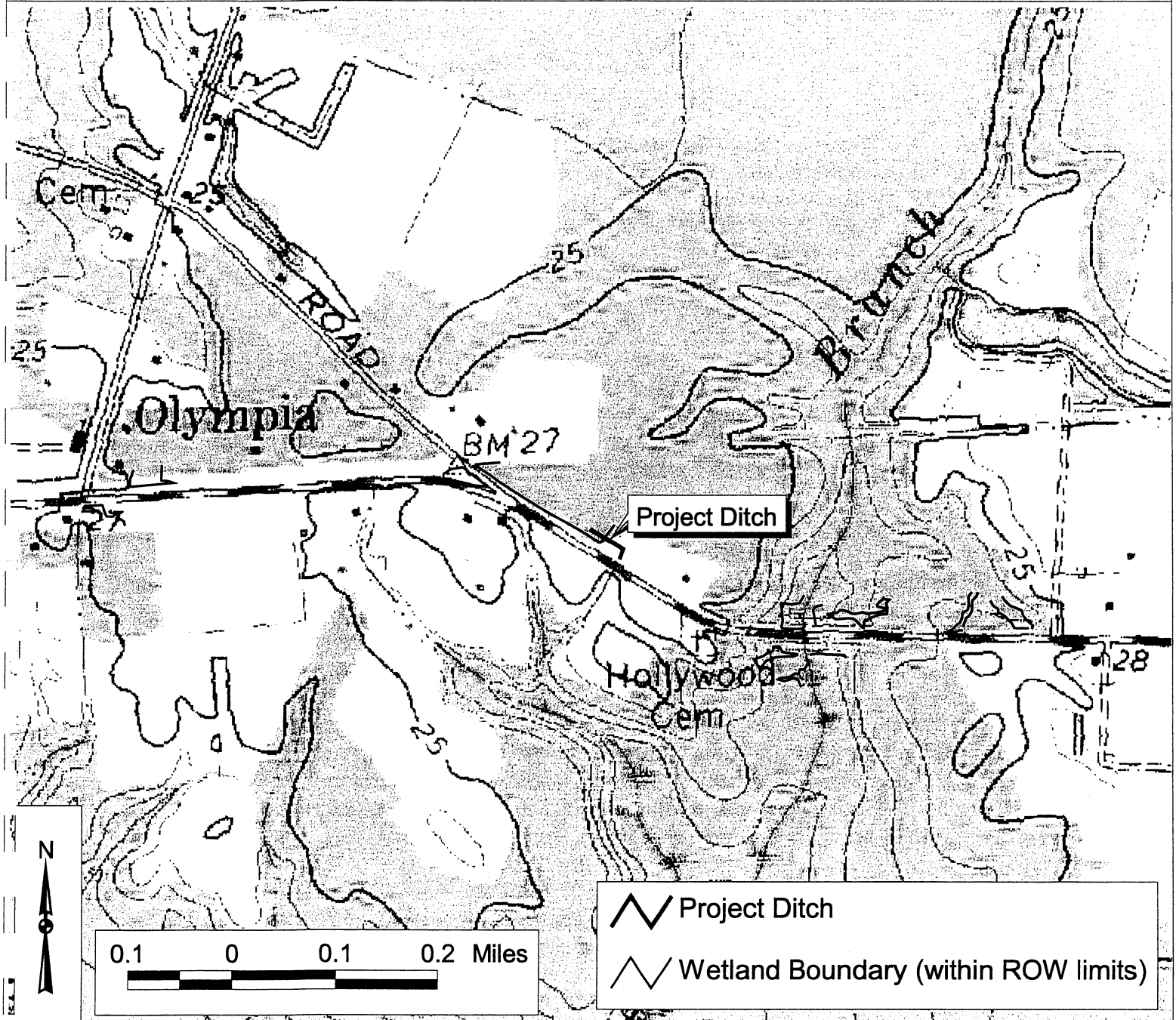
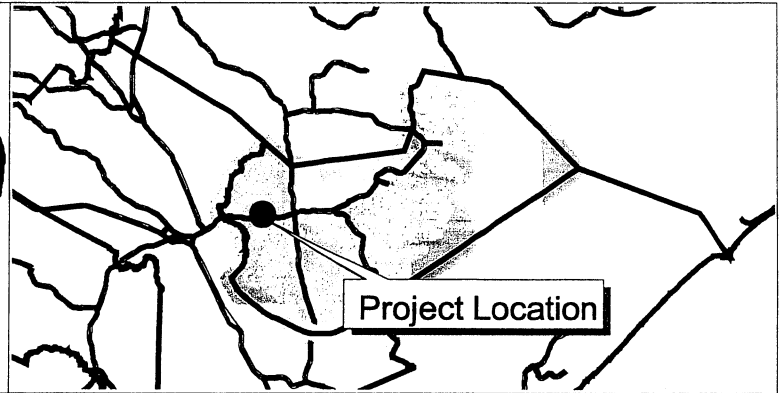
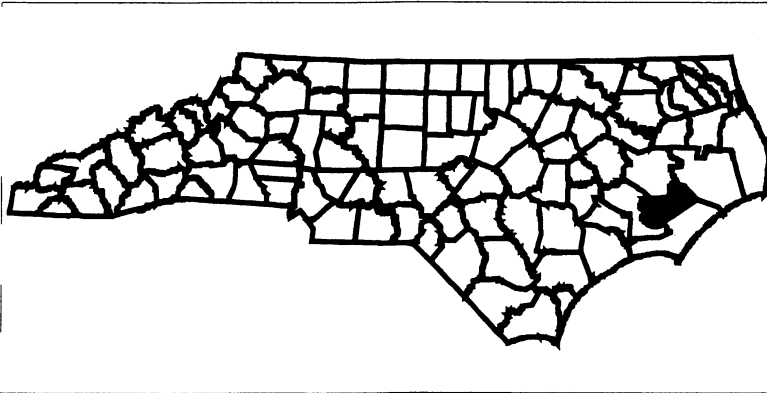

Site Location

NC-55 Ditch Analysis
Pamlico County, NC

Drawn By: MTC	Date: July 2003
Chkd By: APS	Project No: 02-113.23
SCALE: AS SHOWN	

2.0 METHODS

MODEL DESCRIPTIONS

The Boussinesq Equation represents a two dimensional general flow equation for unconfined aquifers. The equation has been applied in the past to predict the decline in elevation of the water table near a pumping well as time progresses. The equation is based primarily on hydraulic conductivity, drainable porosity, and the saturated thickness of the aquifer. One form of the equation is as follows:

$$X = (K h_0 t/f)^{1/2} F(D,H)$$

Where:

K = hydraulic conductivity (in/hr)

h_0 = depth to aquiclude (in)

t = duration (hours)

f = drainable porosity (dimensionless ratio)

F(D,H) = profiles (graphs) relating ditch depth, water table depth, and depth to the aquiclude(h_0)

X = wetland impact distance (in)

DRAINMOD was originally developed to simulate the performance of agricultural drainage and water table control systems on sites with shallow water table conditions. DRAINMOD predicts water balances in the soil-water regime at the midpoint between two drains of equal elevation. The model is capable of calculating hourly values for water table depth, surface runoff, subsurface drainage, infiltration, and actual evapotranspiration over long periods referenced to measured climatological data. The reliability of DRAINMOD has been tested for a wide range of soil, crop, and climatological conditions. Results of tests in North Carolina (Skaggs, 1982), Ohio (Skaggs *et al.* 1981), Louisiana (Gayle *et al.* 1985; Fouss *et al.* 1987), Florida (Rogers 1985), Michigan (Belcher and Merva 1987), and Belgium (Susanto *et al.* 1987) indicate that the model can be used to reliably predict water table elevations and drain flow rates. DRAINMOD has also been used to evaluate wetland hydrology by Skaggs *et al.* (1993). Methods for evaluating water balance equations and equation variables are discussed in detail in Skaggs (1980).

DRAINMOD was modified for application in wetland studies by adding a counter that accumulates the number of events wherein the water table rises above a specified depth and remains above that threshold depth for a given duration during the growing season. Important inputs into the DRAINMOD model include rainfall data, soil and surface storage parameters, evapotranspiration rates, ditch depth and spacing, and hydraulic conductivity values.

MODEL APPLICATION

In this study, the Boussinesq equation was applied to a ditch one foot (0.3 meter) deep to predict where the linear distance of a drawdown in the groundwater exceeds 1 foot for 5- and 12.5-percent of the growing season. These percentages were selected based upon guidance from the U.S. Army Corps of Engineers Wetland Delineation Manual (DOA 1987). We solve the equation for the Wetland Impact Distance with data for the following variables: 1) equivalent hydraulic conductivity; 2) drainable porosity; 3) an estimated depth to the aquiclude, based on regional data; 4) the time duration of the drawdown; 5) target water table depth (1 foot below the soil surface); and 6) ditch depth identified in construction plans.

The dominant soil type along the project ditch is the Lynchburg series, which was determined based upon the Pamlico County soil survey (USDA 1987) and verified in the field. Equivalent hydraulic conductivity (K) was estimated by calculating a weighted average of conductivity data generated by the NRCS-MUUF computer model (Baumer *et al.* 1994) and field measured saturated hydraulic conductivity for the Lynchburg series, cross referenced with values provided in the Pamlico County soil survey. The soil layer depths were obtained from descriptions in the Pamlico County soil survey and verified in the field. For the Lynchburg soil, drainable porosity was calculated using the water depth to drained-volume relationship provided by MUUF. The depth to aquiclude was assumed to be 10 feet. The time variable, t, is based on a 5- and 12.5-percent of the Pamlico County growing season. For the purpose of this study, the growing season is defined as the period between March 7 and November 23 (USDA 1987). Values for F(D,H) were taken from plotted numerical solutions to the Boussinesq equation (Skaggs 1980) where $D=h_0 - (\text{ditch depth} / \text{divided } h_0)$ and $H= h / h_0$. The variable h is equal to the height after drawdown for the water above the aquiclude at distance X from the ditch.

DRAINMOD was used to model the zone of wetland loss resulting from the addition of the project ditch. This zone was derived by determining the threshold drain spacing that would result in the area adjacent to the project ditch meeting the wetland hydrology criterion in just over half of the years simulated. Drains spaced any closer than this threshold distance would result in the entire area experiencing a loss of wetland hydrology. If drains were spaced any further apart than the threshold distance, there would be a strip between the drains which would still meet the wetland hydrology criteria. If only one drain exists, areas outside of half of the threshold distance would still have wetland hydrology. Half of this threshold spacing provides a conservative estimate of the drainage effect that the project ditch will have.

Wetland hydrology is defined for DRAINMOD as groundwater within 12 inches of the ground surface for 14 and 33 consecutive days during the growing season (5- and 12.5-percent of the growing season). Wetland hydrology is achieved in the model if target hydroperiods are met for one half of the years modeled (i.e. 23 out of 45 years). Inputs for soil parameters such as the water table depth/volume drained/upflux relationship, Green-ampt parameters, and the water content/matric suction relationship were obtained from NRCS data utilizing the MUUF computer program. Hydraulic conductivities and ditch depth were calculated as described above. Weather data for a 45 year period was obtained for the New Bern airport located approximately six miles away from the site. Potential evapotranspiration rates calculated based on Thornthwaite's method were adjusted using monthly factors from Washington County. The DRAINMOD simulation was conducted for the time period from 1949 to 1993.

3.0 RESULTS AND CONCLUSIONS

Applying the Boussinesq equation with an equivalent K of 3.66 in/hr, depth to the aquiclude (h_0) of 10 feet, drainable porosity of 0.037, ditch depth of 1 foot, time duration of 14 days (5-percent) and 33 days (12.5-percent), $D=0.9$, $H=0.9$, and F(D,H) of 13, it was predicted that the drainage impact of the ditch would be at least 13 feet for the 14-day scenario and 20 feet for 33 days. DRAINMOD predicted that the ditch effect would be less than 115 feet for 5-percent of the growing season and less than 1,205 feet for 12.5-percent of the growing season. DRAINMOD results predict a *zone* of influence rather than a specific point in the landscape where hydrologic influences are no longer jurisdictional. Model parameters and outputs are provided in Tables 1 and 2. A graphical depiction of the drainage impact from the project ditch to adjacent wetlands is provided in Figure 2.

Table 1. Boussinesq Equation Variables and Results

Boussinesq Equation							
Average K (ft)	h_0 (inches)	t (days)	f	DDitch (ft)	D	F(D,H)	X (ft)
3.66	120	14	0.037	1	0.9	13	13.0
3.66	120	33	0.037	1	0.9	13	20.0

X (Wetland Impact Distance) = $(K h_0 t/f)^{1/2} / F(D,H)$

Where:

K=hydraulic conductivity (in/hr)

h_0 =depth to aquiclude (in)

t= duration (hours)

f=drainable porosity (dimensionless ratio)

F(D,H)=Profiles (graphs) relating ditch depth, water table depth, and depth to the aquiclude(h_0)

Table 2. Drainmod Input/Output for Project Ditch

ANALYSIS OF WETLAND HYDROLOGIC CRITERIA for Lynchburg soil in Pamlico Co., NC
for FOREST: STMAX=2.5cm, STORR=1.5, thwtd=30cm/14days, Ksat=15,4.5, 15

Drain spacing = 7000. cm Drain depth = 30.0 cm

Number of periods with water table closer than 30.00 cm for at least 14 days (5-percent) during the Pamlico County growing season. Counting starts on day 66 and ends on day 327 of each year

Year	No. of Periods of 14 days or more with WTD < 30.0 cm	Longest Consecutive Period In Days	Year	No. of Periods of 14 days or more with WTD < 30.0 cm	Longest Consecutive Period In Days
1949	0	0	1981	0	11
1950	0	9	1982	0	9
1951	0	11	1983	2	42
1952	1	15	1984	1	16
1953	0	10	1985	0	13
1954	0	5	1986	0	12
1955	1	19	1987	0	9
1956	1	19	1988	0	13
1957	0	11	1989	3	21
1958	1	18	1990	0	10
1959	3	19	1991	2	19
1960	1	19	1992	1	17
1961	1	15	1993	0	10
1962	1	21			
1963	0	12			
1964	0	13			
1965	1	15			
1966	1	16			
1967	0	10			
1968	0	13			
1969	2	20			
1970	1	16			
1971	1	15			
1972	0	11			
1973	0	7			
1974	2	23			
1975	1	17			
1976	1	34			
1977	1	15			
1978	0	12			
1979	0	10			
1980	1	28			

Number of Years with at least one period = 23. out of 45 years.

Table 3. Drainmod Input/Output for Project Ditch

ANALYSIS OF WETLAND HYDROLOGIC CRITERIA for Lynchburg soil in Pamlico Co., NC
for FOREST: STMAX=2.5cm, STORR=1.5, thwtd=30cm/14days, Ksat=15,4.5, 15

Drain spacing = 73,500. cm Drain depth = 30.0 cm
Number of periods with water table closer than 30.00 cm for at least 33 days (12.5-percent)
during the Pamlico County growing season. Counting starts on day 66 and ends on day 327 of
each year

Year	No. of Periods of 14 days or more with WTD < 30.0 cm	Longest Consecutive Period In Days	Year	No. of Periods of 14 days or more with WTD < 30.0 cm	Longest Consecutive Period In Days
1949	0	0	1981	0	32
1950	1	38	1982	1	34
1951	0	28	1983	1	54
1952	0	29	1984	2	54
1953	0	21	1985	1	33
1954	0	20	1986	0	16
1955	0	24	1987	1	36
1956	2	51	1988	0	29
1957	1	38	1989	1	65
1958	1	46	1990	0	29
1959	1	41	1991	2	47
1960	0	23	1992	1	35
1961	0	21	1993	1	47
1962	0	25			
1963	0	19			
1964	2	43			
1965	0	31			
1966	0	29			
1967	1	46			
1968	0	22			
1969	0	30			
1970	1	42			
1971	1	55			
1972	0	21			
1973	0	15			
1974	2	52			
1975	0	23			
1976	1	34			
1977	1	42			
1978	0	25			
1979	2	50			
1980	1	35			

Number of Years with at least one period = 23 out of 45 years.



Prepared For:
 North Carolina
 Department of
 Transportation

Project:
 NC-55 Widening
 Ditch Impact Analysis
 Pamlico County
 North Carolina

Figure Name
 Proposed Impact of Project
 Ditch on Adjacent Wetlands
 Boussinesq Equation
 compared to
 DRAINMOD

Drawn By: MTC	Date: July 2003
Chkd By: APS	Project No.: 02-113.23

SCALE:
AS SHOWN

FIGURE
2



Project Ditch Location

Wetland Delineation (within ROW)

DRAINAGE IMPACT

- 12.8-ft (Boussinesq)
- 20-ft (Boussinesq)
- 115-ft (DRAINMOD)
- 1205-ft (DRAINMOD)

Both methods have an ability to support different ditch morphology and features, suggesting that use of these methods in evaluation of drainage impacts from highway ditches is applicable with proper data inputs that fully reflect the differences between highway ditches and agricultural ditches. Performing a comparison of output from both methods is recommended, because their output can be used to predict the lower and upper limits of a range of drainage influence that is likely to occur in real world conditions.

The Boussinesq Equation does not consider the hydroperiod in which the water table drops below 12 inches, therefore the equation does not exhibit any relation to wetland hydrology. Additionally, the Boussinesq Equation requires that different lateral hydraulic conductivities for separate soil layers be combined in a weighted average for use in the equation. Using only one weighted lateral hydraulic conductivity is limiting in comparison to DRAINMOD, which allows the entry of a different lateral hydraulic conductivity for each soil layer. This is an important factor, considering that drainage in the Lynchburg Soil series is considerably different within three separate soil layers that all occur within 80 inches of the surface. In Lynchburg soils, entering a weighted average for lateral hydraulic conductivity has resulted in a lower overall permeability than was measured in the field. The predictive outcome of the Boussinesq equation therefore reflects a cumulatively smaller distance being influenced by the project ditch than may occur if the hydraulic conductivity for all soil layers were considered.

DRAINMOD represents an alternative model that assesses wetland hydroperiods. DRAINMOD uses the ellipse equation as a base-line component of the model. DRAINMOD assesses variability in rainfall, other hydrologic parameters, and adds a time function (counter) that predicts the ditch spacing required to lower the water table below 12 inches for a wetland related hydroperiod. The results from DRAINMOD may have been influenced by shallow dimensions of the project ditch and the marginal wetness that exists naturally in the adjacent areas. In addition, DRAINMOD results predict a zone of influence rather than a specific distance of influence. These results suggest that actual impacts to the wetland hydroperiod will be somewhat less than the 115-foot maximum limit predicted by the model for the 5-percent scenario and less than 1,205 feet for the 12.5-percent model.

In summary, two different methods were used to simulate the drainage impact of a special ditch on the wetland hydroperiod within jurisdictional systems adjacent to NC-55 in Pamlico County. The Boussinesq Equation and DRAINMOD model were utilized to predict the lateral extent of the ditch impact on ground or surface water within one foot of the land surface for various jurisdictional thresholds (*i.e.* 5- or 12.5-percent of the growing season). The Boussinesq Equation determined that wetlands within 13 to 20 feet of the special ditch would be adversely affected by ditch placement within, or adjacent to, wetlands which previously exhibited hydroperiods of five to 12.5 percent of the growing season, respectively. However, it should be noted that the Boussinesq Equation appears to be sensitive to changes in several equation parameters, particularly hydraulic conductivity values. By combining hydraulic conductivities derived from various soils layers and utilizing a mean value in the equation, variability in lateral drainage characteristics within a particular soil type may be masked. The result could potentially be an under-reporting of the lateral extent of drainage impacts on adjacent hydroperiods.

DRAINMOD results indicate an impact zone of 115 feet to 1,205 feet within wetland with pre-project jurisdictional hydroperiods of 5- to 12.5-percent, respectively. However, results are not necessarily absolute and the data only infers that the jurisdictional status of the wetland will be adversely affected somewhere within the reported zone of influence. In addition, the shallow

depth of the special ditch under investigation (i.e. less than one foot) and the lack of repetitive sampling at several locations does not provide for a sensitivity analysis of reported results. Model parameters were estimated based primarily on published information, supplemented by limited field investigation and the modal concept for soil series in the region. Neither of these methods was designed to model highway ditching activities since both models were developed for agricultural ditches. It is recommended that additional sampling be undertaken at multiple sites with similar soil characteristics in order to obtain a database of reliable, field tested information for highway-related projects.

4.0 REFERENCES

- Baumer, O. et al. 1994. MUUF v2.14 Users Manual. Natural Resource Conservation Service.
- Belcher, H.W. and G.E. Merva. 1987. Results of DRAINMOD verification study for Zeigenfuss soil and Michigan climate. ASAE Paper No. 87-2554. ASAE, St. Joseph, MI 49085.
- Fouss, J.L., R.L. Bengtson and C.E. Carter. 1987. Simulating subsurface drainage in the lower Mississippi Valley with DRAINMOD. Transactions of the ASAE 30 (6).(1679 -1688).
- Gayle, G., R.W. Skaggs and C.E. Carter. 1985. Evaluation of a water management model for a Louisiana sugar cane field. J. of Am. Soc. of Sugar Cane Technologists, 4: 18 - 28.
- Rogers, J.S. 1985. Water management model evaluation for shallow sandy soils. Transactions of the ASAE 28 (3): 785-790.
- Skaggs, R.W. 1980. Drainmod Reference Report. Methods for Design and Evaluation of Drainage Water Management Systems for Soils with High Water Tables. Prepared for the U.S. Department of Agriculture. South National Technical Center. Fort Worth, Texas.
- Skaggs, R.W., N.R. Fausey and B.H. Nolte. 1981. Water management evaluation for North Central Ohio. Transactions of the ASAE 24 (4): 922 - 928.
- Skaggs, R.W. 1982. Field evaluation of a water management simulation model. Transactions of the ASAE 25 (3): 666 - 674.
- Skaggs, R.W., et al. 1993. Methods for Evaluating Wetland Hydrology. ASAE meeting presentation Paper No. 921590. 21 p.
- Susanto, R.H., J. Feyen, W. Dierickx and G. Wyseure. 1987. The use of simulation models to evaluate the performance of subsurface drainage systems. Proc. of Third International Drainage Workshop, Ohio State Univ., pp. A67 - A76.
- U.S. Department of Agriculture (USDA). 1987. Soil Survey of Pamlico County, North Carolina. Natural Resource Conservation Service.
- U.S. Department of Agriculture (USDA). 1971. Natural Resource Conservation Service National Engineering Handbook. Section 6.0: Drainage of Agricultural Land. Equation 4-8, and Pages 4-57 to 4-69. NRCS.

**INDIRECT AND CUMULATIVE
IMPACT STUDY**

**R-2539B, PAMLICO COUNTY,
NORTH CAROLINA**



Infrastructure, buildings, environment, communications

**Indirect and Cumulative Impact
Study**

**R-2539B, Pamlico County,
North Carolina**

**Prepared for:
North Carolina Department of
Transportation**

**Prepared by:
ARCADIS G&M of North Carolina, Inc.
801 Corporate Center Drive
Suite 300
Raleigh
North Carolina 27607
Tel 919 854 1282
Fax 919 854 5448**

**Our Ref.:
NC601041.0007.0539**

**Date:
June 2003**

This document is intended only for the use of the individual or entity for which it was prepared and may contain information that is privileged, confidential, and exempt from disclosure under applicable law. Any dissemination, distribution, or copying of this document is strictly prohibited.

Table of Contents

1. Executive Summary	1
2. Project Description	3
3. Identification of Study Area	3
4. Analysis of Study Area	3
4.1 Demographic Characteristics	3
4.2 Local Economy	4
4.3 Existing Land Use	4
4.4 Natural Environment	5
4.5 Zoning	5
4.6 Land Use Plans	5
4.7 Water and Sewer	6
4.8 Water Quality Plans and Programs	7
4.8.1 Neuse River Basinwide Water Quality Plan	7
4.8.2 Other Programs	8
5. Analysis of Future Growth Potential	9
6. Summary of the Effects of the Project	9
7. References	11

Tables

1	1990-2000 Population Growth for State, County, Census Tract, and Block Groups
---	---

Figures

1	Project Study Area
2	Census Block Groups
3	Pamlico County Land Classifications

1. Executive Summary

The proposed project, TIP No. R-2539B, involves the widening of NC 55 in Pamlico County, North Carolina. The project extends from east of SR 1127 (Bayleaf Road) to east of SR 1129 (Bennett-Tingle Road), a distance of approximately 6.2 miles. The focus of this study is to determine whether or not indirect and cumulative impacts resulting from the project will cause a violation of downstream water quality standards. The report analyzes the area's future growth potential, discusses existing plans and programs affecting water quality, and makes a finding as to associated water quality impacts.

Existing Growth and Development

Land use in the study area is primarily agricultural or forested with pockets of residential and scattered commercial uses. Pamlico County's land use plan indicates that the development potential of the study area is limited due to physical limitations and lack of urban services and utilities. Physical limitations in the study area include flood hazard areas, 404 wetland areas, estuarine waters, special secondary nursery areas, and poorly drained soil areas. Given plans to expand sewer service into the study area, it is likely that some development will occur, especially along NC 55, even without the widening of the roadway. Future development along NC 55 will likely be service-type uses to support residential development, as well as travel-related businesses. This development will be dependent on population growth. Pamlico County and the study area experienced low to moderate population growth from 1990 to 2000. According to Pamlico County's land use plan, most of the recent residential development in the county "has been the result of residential construction along estuarine shoreline areas."

Existing Water Quality

The proposed widening of NC 55 crosses tributaries of Upper Broad Creek and Goose Creek. According to the *Neuse River Basinwide Water Quality Plan*, prepared by the North Carolina Division of Water Quality (DWQ), the portion of the Neuse River that Upper Broad Creek and Goose Creek drain into is currently impaired. The latest recommendations on this area of the subbasin advise continued monitoring and implementation of the Neuse Water Nutrient Sensitive Waters strategy, as well as implementation of the Neuse total nitrogen total maximum daily loads (TMDL).

Water Quality Plans and Programs

Pamlico County has a land use plan certified by the Coastal Resources Commission (CRC). The Division of Coastal Management (DCM) uses the plan to make Coastal Area Management Act (CAMA) permit decisions and federal consistency determinations. Proposed projects and activities must be consistent with the enforceable policies of a local land-use plan or the DCM cannot permit a project to go forward. Development in Pamlico County is also subject to the DWQ coastal county stormwater requirements. All development requiring an erosion and sediment control plan must obtain a stormwater permit and comply with the DWQ regulations.

Growth Resulting From Construction of R-2539B

It is not expected that the widening of NC 55 alone will induce extensive development in the study area. However, with the extension of sewer service into the study area, the project will likely play a cumulative role in generating new development in the study area. The project is expected to play a role in development decisions along the corridor and in proximity to existing communities as permitted by local, state, and federal regulations. Pamlico County's land use plan states that the county will "particularly discourage strip development along NC 55 . . ."

Conclusion

- Development is expected to continue in the study area, especially where the sewer service area is expanded. Non-residential development will be focused on the NC 55 corridor. This development will be dependent on population growth and, to a lesser extent, influenced by the widening of NC 55. Overall development in the study area will be limited due primarily to environmental constraints.
- Existing policies and regulations, including a CAMA land use plan, will manage potential indirect impacts to the area's water quality.
- The construction of TIP Project No. R-2539B is not expected to result in any indirect or cumulative impacts that will adversely affect the water quality within the Neuse River Basin.
- No further indirect or cumulative impact analysis is recommended for the proposed project.

2. Project Description

The proposed project, TIP No. R-2539B, involves the widening of NC 55 in Pamlico County, North Carolina, from two to five lanes. The project extends from east of SR 1127 (Bayleaf Road) to east of SR 1129 (Bennett-Tingle Road), a distance of approximately 6.2 miles. The Environmental Assessment (EA) for the project was completed in 1997.

3. Identification of Study Area

The study area was devised by examining the project's location in relation to political and planning boundaries, watershed boundaries, the role the facility plays in the local network, and the development patterns of the region.

The study area is in western Pamlico County. The small town of Grantsboro is at the eastern edge of the study area. The unincorporated communities of Olympia and Reelsboro are also along NC 55 in the study area. Located in sub-basin 03-04-10 of the Neuse River Basin, the study area includes drainage areas for Upper Broad Creek and Goose Creek. (Information about the Neuse River Basinwide Water Quality Plan is included in Section 4.8, Water Quality Plans and Programs of this report.) The study area is shown in Figure 1.

4. Analysis of Study Area

4.1 Demographic Characteristics

The 1990 and 2000 US Census data were used to gather information on the population of the project study area. Block Groups 5 and 6 of Census Tract 9501 encompass the study area for this project. The boundaries of the block groups and study area are shown in Figure 2.

Population growth in Block Group 5 and Block Group 6 of Census Tract 9501 varied considerably from 1990 to 2000. The population of Block Group 5 increased over 17 percent, while the population of Block Group 6 increased only 1.5 percent. In comparison; the population of Census Tract 9501 increased almost 12 percent and the population of Pamlico County increased slightly more at over 13 percent during the same period. Population growth for the state overall during this 10-year period is higher at 21.4 percent. Residential development in the study area mostly occurred along and to the south of NC 55 in proximity to the Reelsboro community (Block

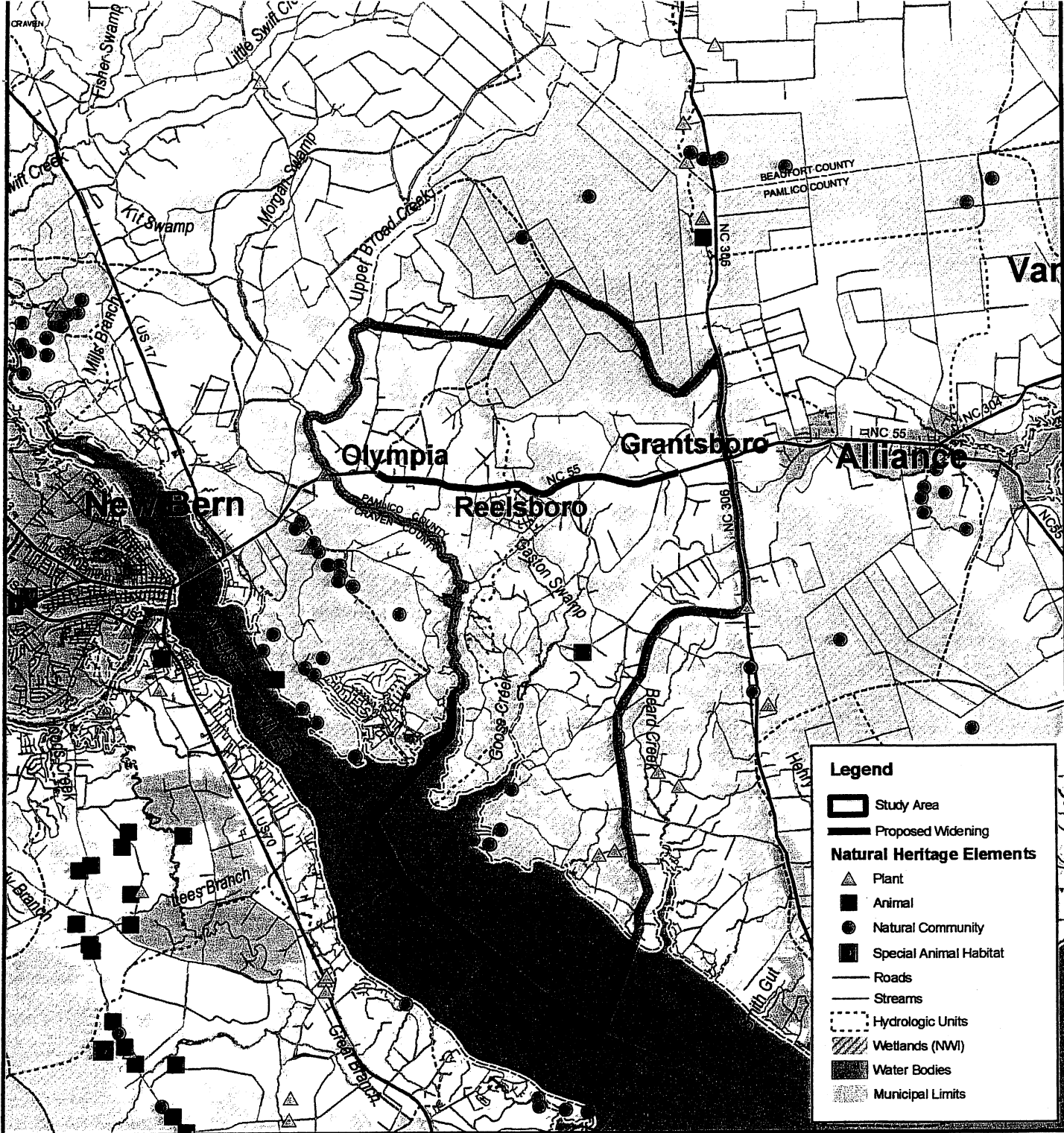

Scale 1:175,887



ARCADIS G&M of North Carolina, Inc.

801 Corporate Center Drive, Suite 300
Raleigh, NC 27607-6073 Tel: 919/854-1282 Fax: 919/854-5448

Prepared For



Source:



PROJECT STUDY AREA

NC 55 WIDENING
T.I.P. No. R-2539B
PAMLICO COUNTY, NORTH CAROLINA

Figure

1

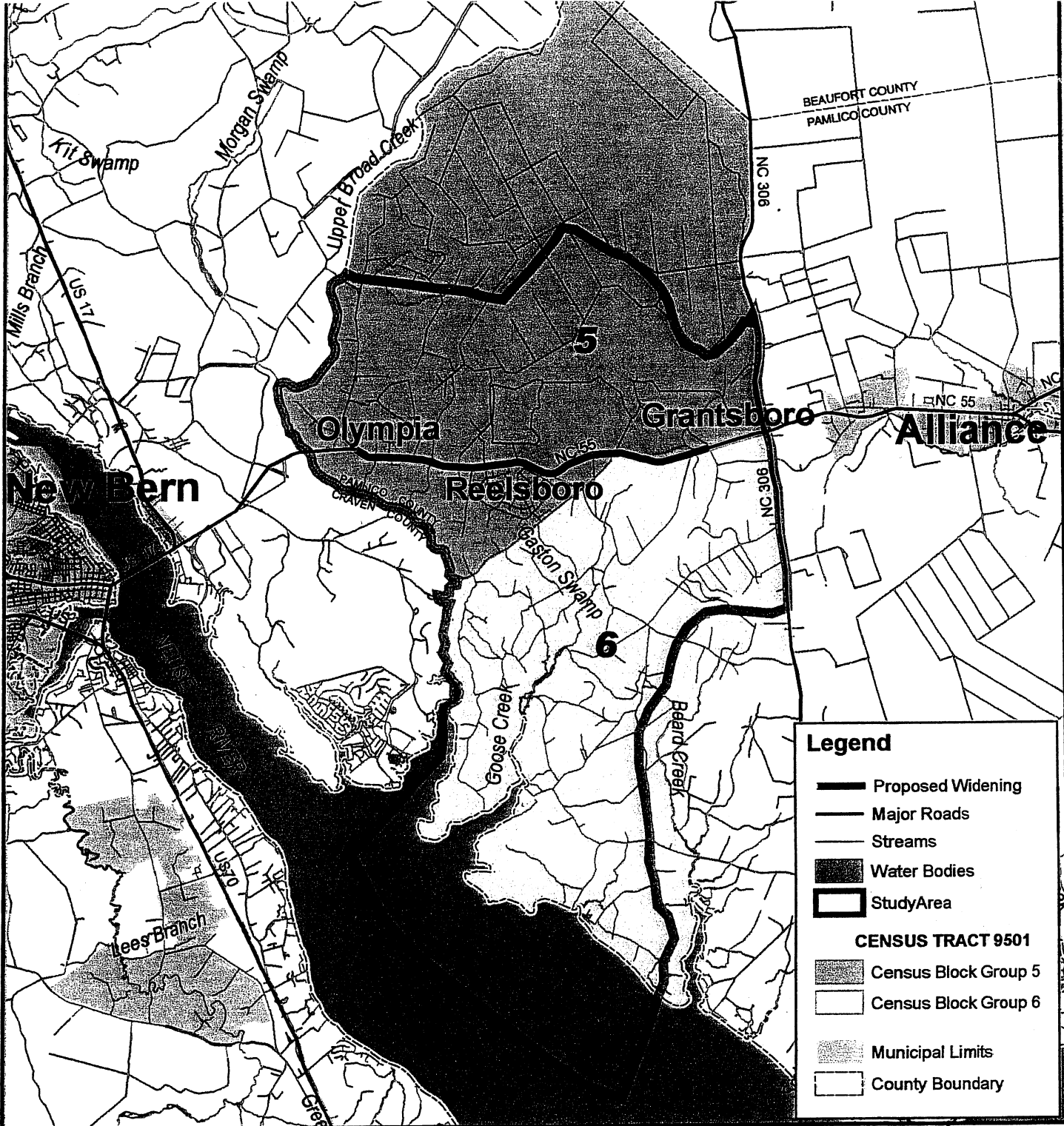

Scale 1:149,691



ARCADIS G&M of North Carolina, Inc.
 801 Corporate Center Drive, Suite 300
 Raleigh, NC 27607-5073 Tel: 919/854-1282 Fax: 919/854-5448

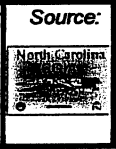
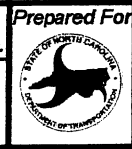

CENSUS BLOCK GROUPS
 NC 55 WIDENING
 T.I.P. No. R-2539B
 PAMLICO COUNTY, NORTH CAROLINA

Figure
2

Group 5). This growth resulted in an additional 151 housing units in Block Group 5, according to census data. It is likely that these new residents use the NC 55 corridor to access services and jobs in the area. Much of Block Group 6 consists of swamp land, which explains the slower growth rates. According to Pamlico County’s land use plan, most of the recent residential development in the county “has been the result of residential construction along estuarine shoreline areas.”

Table 1. 1990 – 2000 Population Growth for State, County, Census Tract, and Block Groups

	2000 Population	1990 Population	% change
North Carolina	8,049,313	6,628,637	21.4%
Pamlico County	12,934	11,372	13.7%
Census Tract 9501	7,305	6,530	11.9%
Block Group 5	1,828	1,554	17.6%
Block Group 6	985	970	1.5%

Note: Grantsboro was recently incorporated and was not listed separately in the 2000 Census.

4.2 Local Economy

According to planning staff, the economy of Pamlico County experienced modest growth in the 1990s. The county has a strong tourist industry that primarily benefits the restaurants, motels, sports fishing, hunting, retail trade, services, construction, real estate, and finance industries. In addition, government sector jobs add to the economic mix. The North Carolina Department of Commerce indicates that 30.4 percent of the workforce is employed in the government sector. The service sector followed with 24.6 percent and the retail trade sector followed with 19.3 percent. In the study area, many of the businesses are service-related businesses located in residences.

4.3 Existing Land Use

The study area is primarily rural. Overall, land use is mostly agricultural or forested with pockets of residential and scattered commercial uses. Residential development includes mostly single-family houses developed linearly along US 55 and NC 306. Commercial uses are also scattered along NC 55, but concentrated in Reelsboro and Grantsboro. Commercial uses in the town of Grantsboro include a gas station,

restaurant, and a post office. In addition, commercial uses include service-sector businesses located in single-family residences throughout the study area. Several churches are also in the study area. Weyerhaeuser has numerous logging operations in the area. Because NC 55 is the primary east-west route in the county, study area residents likely use the roadway to access jobs and services.

4.4 Natural Environment

Geographically the study area is in the Neuse River Basin, the third largest river basin in North Carolina. Specifically, the project is in subbasin 03-04-10. The southern boundary of the study area is the Neuse River. Upper Broad Creek and Goose Creek are the major streams in the study area. The project will cross several tributaries of these creeks, including Sasses Branch, Deep Run, and East Fork Goose Creek. Other tributaries in the study area include West Fork Goose Creek, Deep Run Branch, Simmons Branch, Black Creek, Gaston Swamp, Cypress Creek, and Alexander Swamp. Both Upper Broad Creek and Goose Creek are Class C swamp waters, and transition to Class SB, then Class SC swamp waters before reaching the Neuse River. The Class C designation refers to waters suitable for aquatic life propagation and survival, fishing, wildlife, secondary recreation, and agriculture. The Class SC designation refers to tidal salt waters suitable for aquatic life propagation and survival, fishing, wildlife, and secondary recreation; the Class SB designation refers to tidal salt waters suitable for primary recreation. The swamp water designation is a supplemental water classification including waters having low velocities and other natural characteristics, which are different from adjacent streams.

The study area contains a large area of pocosins and wooded swamps (404 wetlands). Because of these areas, the mostly forested character of the study area has been and should continue to be preserved.

4.5 Zoning

Neither the town of Grantsboro nor Pamlico County currently has zoning ordinances. However, the county updated its subdivision ordinance to improve the regulation of subdivision construction.

4.6 Land Use Plans

Pamlico County is required by the CAMA to have a local land use plan in accordance with guidelines established by the CRC. Pamlico County's land use plan was certified

by the CRC in 1992. The CRC guidelines require that the following five issues be addressed in the plan:

- Resource Protection,
- Resource Production and Management,
- Economic and Community Development,
- Continuing Public Participation, and
- Storm Hazard Mitigation, Post-Disaster Recovery, and Evacuation Plans.

Pamlico County's Land Classification Map indicates that the majority of the study area, especially on the south side of NC 55, is classified as "rural with services." This classification refers to very low-density, primarily residential areas, where water services are available to avert existing or potential health problems. The unincorporated community of Reelsboro, on NC 55, and the town of Grantsboro, on the eastern edge of the study area, are classified as "community" areas. This classification refers to low-density, developed areas where only limited public services are available. Grantsboro does not have a separate land use plan.

Most of the study area north of NC 55 is listed as an "Area of Environmental Concern and other Fragile Areas" in the *Pamlico County 1992 Land Use Plan Update* and is not likely to experience development. (Note: Fragile areas are defined as areas that "could easily be damaged or destroyed by inappropriate or poorly planned development.") The Pamlico County Land Classifications map is shown in Figure 3.

In addition, Pamlico County's land use plan includes a number of transportation policies. The land use plan specifies that the county should regulate future growth and development along transportation routes. Concerning the NC 55 widening project, the land use plan states that the county will "particularly discourage strip development along NC 55 . . ."

4.7 Water and Sewer

Pamlico County provides water to the developed areas of the study area. The county's water system includes water lines installed along most of the major roads in the county.

The preparation of this map was financed in part through a grant provided by the North Carolina Coastal Management Program, through funds provided by the Coastal Zone Management Act of 1972, as amended, which is administered by the Office of Ocean and Coastal Resource Management, National Oceanic and Atmospheric Administration.

BEAUFORT COUNTY

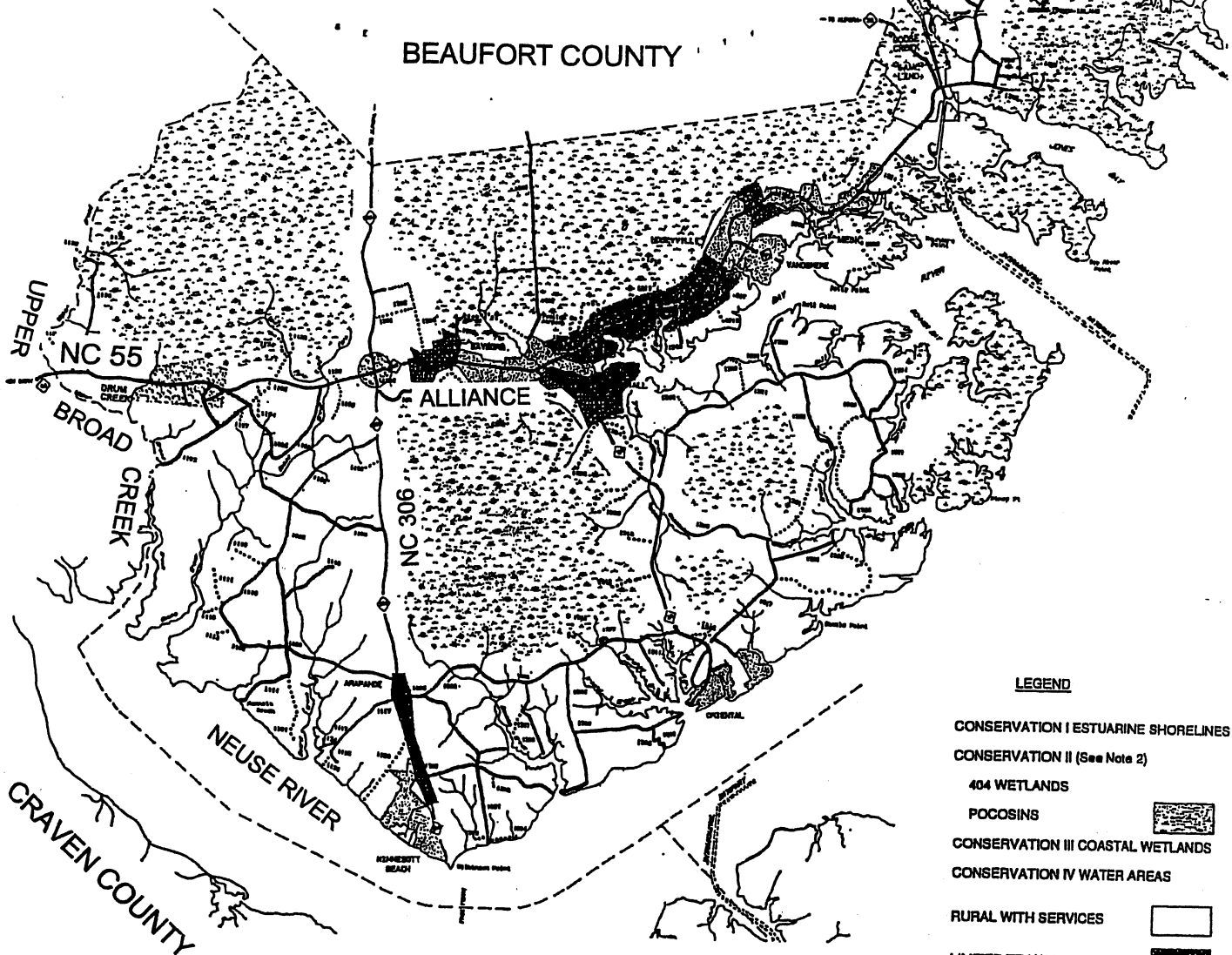

LEGEND

- CONSERVATION I ESTUARINE SHORELINES I
- CONSERVATION II (See Note 2)
- 404 WETLANDS
- POCOSINS
- CONSERVATION III COASTAL WETLANDS
- CONSERVATION IV WATER AREAS
- RURAL WITH SERVICES
- LIMITED TRANSITION
- COMMUNITY
- DEVELOPED
- PAVED ROADS
- UNPAVED ROADS

PAMLICO COUNTY LAND CLASSIFICATIONS

Source: 1992 Pamlico County Land Use Plan Update

ARCADIS G&M of North Carolina, Inc.

801 Corporate Center Drive
Raleigh, NC 27607-5073
Tel: 919/854-1282 Fax: 919/854-5448

Prepared for:



Indirect & Cumulative Impacts

**TIP Project R-2539B
Pamlico County, North Carolina**

**Figure
3**

The water system is supplied by aquifers and is currently operating at approximately 40 percent capacity according to the Pamlico County Water Department.

Pamlico County's *1992 Land Use Plan Update* notes that much of the county is not suitable for septic tanks due to poor soil permeability. However, most of the residents in the study area rely upon individual septic tanks for sewage disposal as there are no wastewater treatment or disposal facilities serving the entire study area. An independent sewer district authority, the Bay River Metropolitan Sewerage District, is Pamlico County's sewer service provider. The sewerage district currently serves only the easternmost portion of the study area. However, work to extend sewer service westward to the Reelsboro community will begin shortly and is scheduled to be complete within two years.

4.8 Water Quality Plans and Programs

As stated above, the CAMA requires Pamlico County to have a local land use plan in accordance with guidelines established by the CRC. The land use plan adopted by the county includes sections on natural resources and fragile areas as well as the importance of marine resources. The land use plan also includes a broad policy statement concerning the county's protection of its natural resources as future development occurs. It is Pamlico County's policy to cooperate with the North Carolina Department of Transportation (NCDOT), the North Carolina Division of Environmental Management (DEM), and other state agencies in mitigating the impact of stormwater runoff on all conservation classified areas. The policy goes on to state that the county will actively support the DEM stormwater runoff retention permitting process.

4.8.1 Neuse River Basinwide Water Quality Plan

The *Neuse River Basinwide Water Quality Plan* specifically addresses the status of Upper Broad Creek and Goose Creek and the section of the Neuse River that they drain into. The portion of the Neuse River that these creeks drain into is currently impaired. Ambient monitoring stations have been set up as part of the Neuse River Estuary Modeling and Monitoring project (MODMON). In addition, a benthic macroinvertebrate monitoring site has been established on Upper Broad Creek where it crosses NC 55 and on Goose Creek near SR 1100. The latest recommendations on this area of the subbasin advise continued monitoring and implementation of the Neuse Water Nutrient Sensitive Waters strategy, as well as implementation of the Neuse total nitrogen total daily maximum loads (TMDL). Because of the complex nature of

estuarine waters, longer periods of data collection and monitoring of management strategies will be needed before water quality goals are met.

The DWQ requires facilities that discharge to any of the state's surface waters to have a National Pollution Discharge Elimination System (NPDES) permit. The permit includes effluent limits that define the load of specific pollutants that may be discharged. According to Section B – Chapter 10 of the *Neuse River Basinwide Water Quality Plan*, there are 19 NPDES wastewater discharge permits in Subbasin 03-04-10. None of these dischargers are in the study area.

Pamlico County is required to comply with the DWQ coastal county stormwater requirements. The goal of these requirements, as with other stormwater programs administered by the DWQ, is to protect surface waters by preventing pollution from entering the waters of the state via stormwater runoff. All development requiring an erosion and sediment control plan must obtain a stormwater permit. The stormwater regulations require developments to maintain a low density of impervious surfaces, maintain vegetative buffers, and transport runoff through vegetative conveyances. Where the low-density criteria cannot be met, the installation of structural best management practices (BMPs) is required to collect and treat the development's stormwater runoff.

4.8.2 Other Programs

Programs are in place to minimize direct, indirect, and cumulative impacts due to the construction of the proposed project and other NCDOT projects that will be built in the study area. These requirements, which are specific to the NCDOT, are precautions taken to protect water quality in the study area and downstream. The NCDOT activities such as general maintenance operations and facilities, construction operations including temporary erosion and sediment control, and project planning and design must comply with standards set forth in the NCDOT handbook titled, "Best Management Practices for Protection of Surface Waters." BMPs include preventative and control measures undertaken to avoid or reduce water pollution.

A NPDES permit that applies throughout the state on NCDOT-owned right-of-way was issued on June 8, 1998. Requirements contained in the permit address a broad range of NCDOT activities. Included is a requirement for development of a procedure to document newly constructed stormwater outfalls and add them to a stormwater system inventory of existing facilities. This documentation process will include the development of project stormwater management plans.

5. Analysis of Future Growth Potential

Future development in the study area will be primarily influenced by environmental constraints and the availability of water and sewer infrastructure. Environmental constraints in the study area include flood hazard areas, 404 wetland areas, estuarine waters, special secondary nursery areas, and poorly drained soil areas. Although adequate water supply does not seem to be a concern in the study area, the availability of a centralized sewage treatment system is limiting growth to some degree in the study area. Development regulations and policies, transportation infrastructure, and population growth also play a role in the development of the area.

According to the *Pamlico County 1992 Land Use Plan Update*, there are limited areas of Pamlico County that are suited for development. The plan predicts that environmental constraints will limit development and “restrict expansion of the county’s water and sewer systems and cause all development to continue to be concentrated along shoreline areas and in “corridors” along state and secondary roads in the interior areas of the county.” Development is likely to occur in incorporated towns and rural communities. In the study area, development is likely to continue along the NC 55 corridor, especially in sewage system expansion areas.

6. Summary of the Effects of the Project

The Council on Environmental Quality defines indirect impacts as those, “. . . which are caused by the action and are later in time or farther removed in distance, but are still reasonably foreseeable (40 CFR 1508.8).” Cumulative impacts are defined as, “. . . impacts on the environment which result from the incremental impact of the action when added to other past, present, and reasonably foreseeable future actions regardless of what agency (federal or nonfederal) or person undertakes such other actions (40 CFR 1508.7).”

Indirect impacts of transportation decisions can involve changes in the type, density, design and locations of development. Influences or disturbances caused by urban development such as increased runoff from impervious areas, erosion and sedimentation, disturbance of riparian vegetation, development in the riparian zone, and pollutant loading can have a cumulative effect on future water quality.

It is likely that some development will occur in the study area, especially along NC 55, even without the widening of the roadway. The expansion of the sewer service area will largely influence development decisions in the study area. Future development

along NC 55 will likely be service-type uses to support residential development, as well as travel-related businesses. This development will be dependent on population growth. Pamlico County and the study area experienced low to moderate population growth from 1990 to 2000. According to Pamlico County's land use plan, most of the recent residential development in the county "has been the result of residential construction along estuarine shoreline areas."

The widening of NC 55, which will accommodate increasing traffic in the area, will play a role in development decisions along the corridor and in adjacent areas as permitted by local, state, and federal regulations. It is not expected that the project alone will result in increased development in the study area. However, with the extension of the Bay River Metropolitan Sewerage District west to the Reelsboro community, the project will likely play a cumulative role in generating new development in the study area. The roadway design, as a five-lane facility, will also play a role in development decisions. Future development will continue to be limited by local regulations and environmental constraints.

Conclusion

Development is expected to continue in the study area, especially where the sewer service area is expanded. Non-residential development will be focused on the NC 55 corridor. This development will be dependent on population growth and, to a lesser extent, influenced by the widening of NC 55. Overall development in the study area will be limited due primarily to environmental constraints. Existing policies and regulations, including a CAMA land use plan, will manage potential indirect impacts to the area's water quality.

Although some development is expected in the study area, the overall indirect and cumulative impacts resulting from the construction of TIP Project No. R-2539B are expected to be minimal because of development limitations and regulations. Therefore, it is determined that construction of TIP Project No. U-2539B will not result in indirect or cumulative impacts that will adversely affect water quality within the Neuse River Basin. No further indirect or cumulative impact analysis is recommended for the proposed project.

7. References

- Bay River Metropolitan Sewer. Personal communication to R. Pugh, ARCADIS, May 2003.
- Council on Environmental Quality. Regulations for Implementing the Procedural Provisions of the National Environmental Policy Act (40 CFR 1508.7 and 1508.8).
- North Carolina Department of Commerce. <http://cmedis.commerce.state.nc.us>. Accessed April 2003.
- North Carolina Department of Natural Resources, Division of Coastal Management. <http://dcm2.enr.state.nc.us/Planning/planning.htm>. Accessed April 2003.
- North Carolina Department of Natural Resources, Division of Water Quality Section. *Neuse River Basinwide Water Quality Plan*. July 2002.
- North Carolina Department of Natural Resources, Division of Water Quality Section. <http://h2o.enr.state.nc.us/wqs/>. Accessed April 2003.
- North Carolina Department of Transportation, 1997. *Best Management Practices for the Protection of Surface Waters*.
- Pamlico County, North Carolina. *1992 Land Use Plan Update*. Holland Consulting Planners. July 1992.
- Sawyer, Rhoda. Pamlico County Water Department Supervisor. Personal communication to R. Pugh, ARCADIS, October, 2002.
- United States Census Data. 1990 and 2000. <http://factfinder.census.gov>. Accessed April 2003.

Wetlands

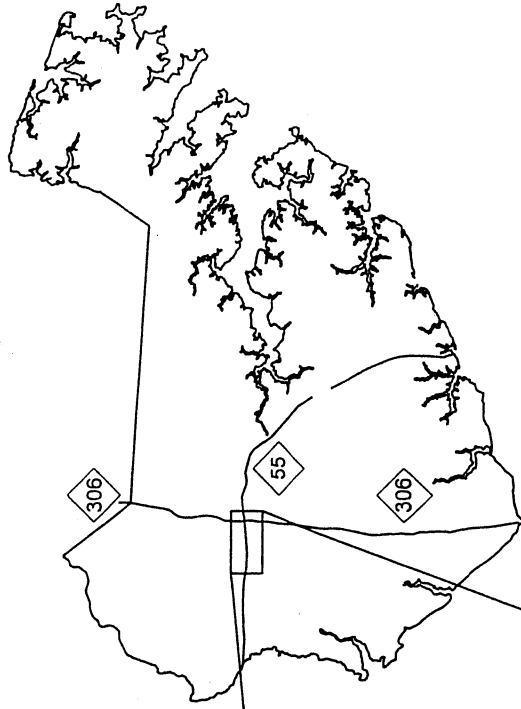
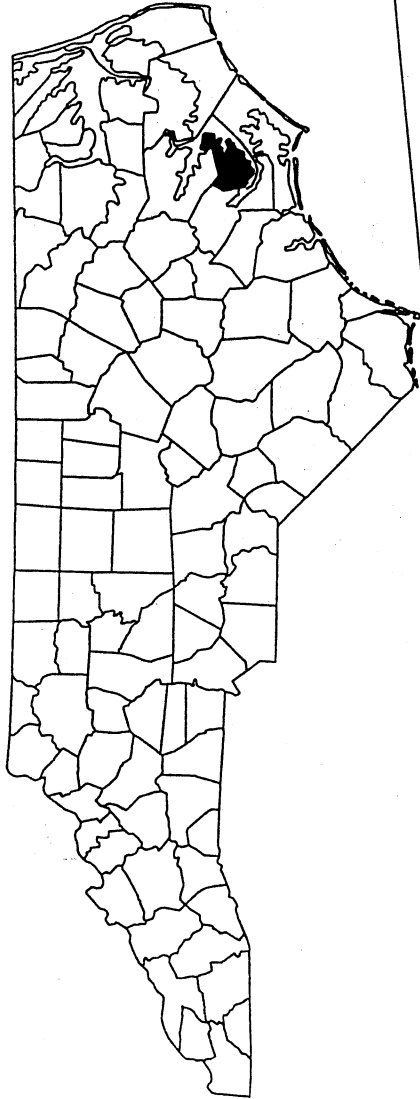

PAMLICO COUNTY

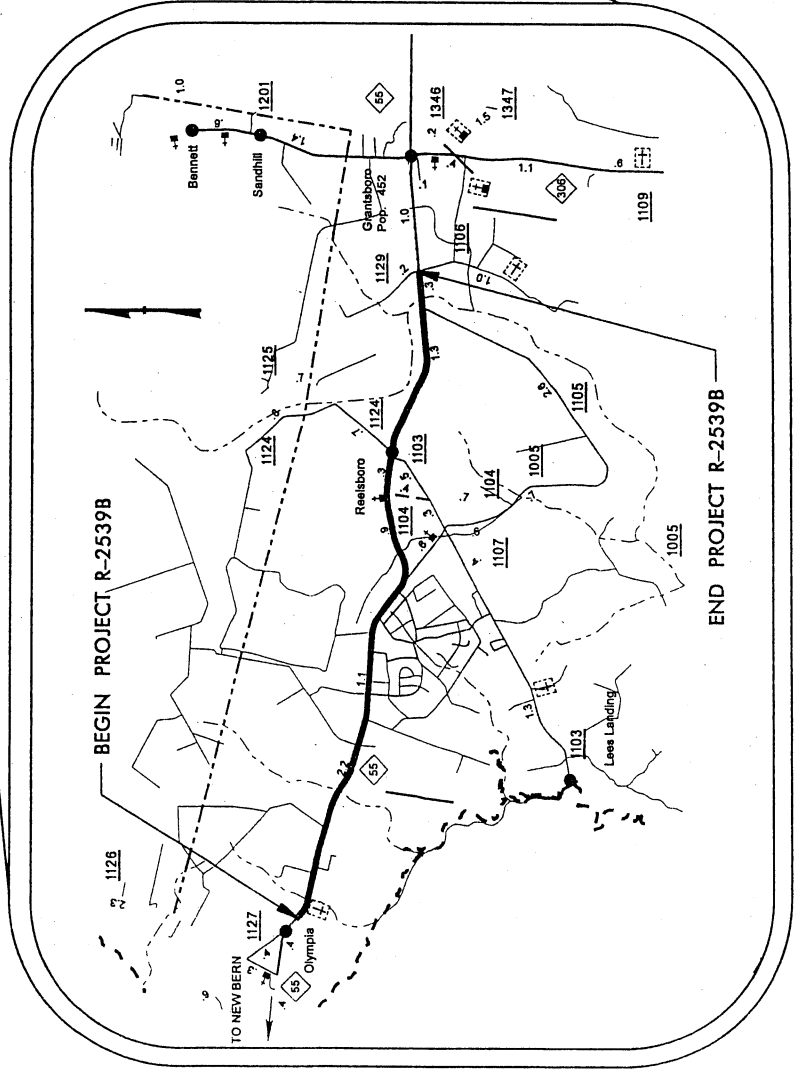

N.C. DEPT. OF TRANSPORTATION
DIVISION OF HIGHWAYS
PAMLICO COUNTY
PROJECT 8.1170901 (R-2539B)
SR 1129
SR 1127 TO EAST OF
SR 1129
SHEET 1 OF 40
05/22/2002

N.C. DEPT. OF TRANSPORTATION
DIVISION OF HIGHWAYS
PAMLICO COUNTY

PROJECT 8.II70901 (R-2539B)

NC 55 FROM EAST OF SR 1127 TO EAST OF
SR 1129

SHEET 2 OF 40

05/22/2002

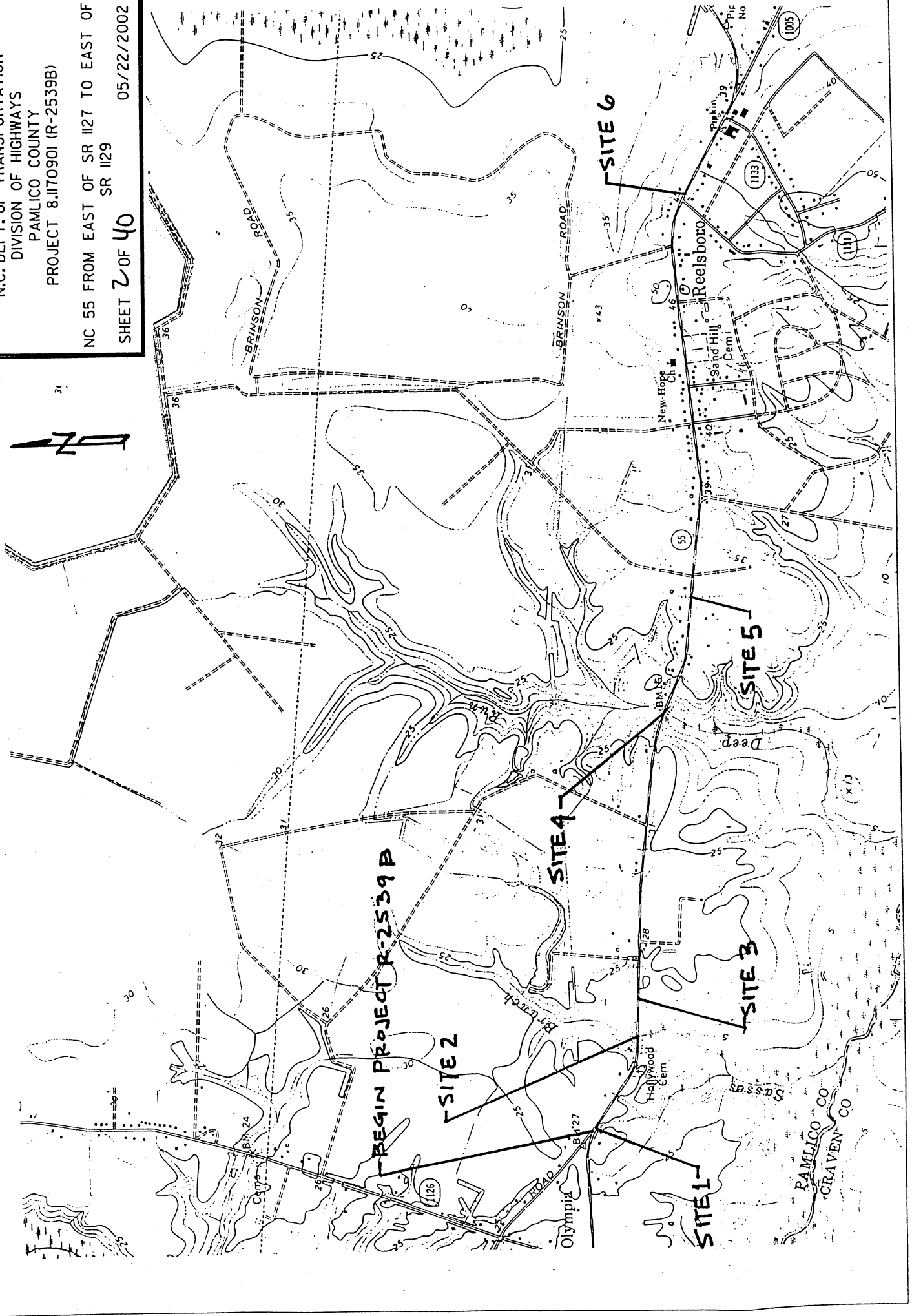
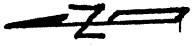

N.C. DEPT. OF TRANSPORTATION
DIVISION OF HIGHWAYS
PAMLICO COUNTY
PROJECT 8.1170901 (R-2539B)

NC 55 FROM EAST OF SR 1127 TO EAST OF
SR 1129
SHEET 3 OF 40 05/22/2002

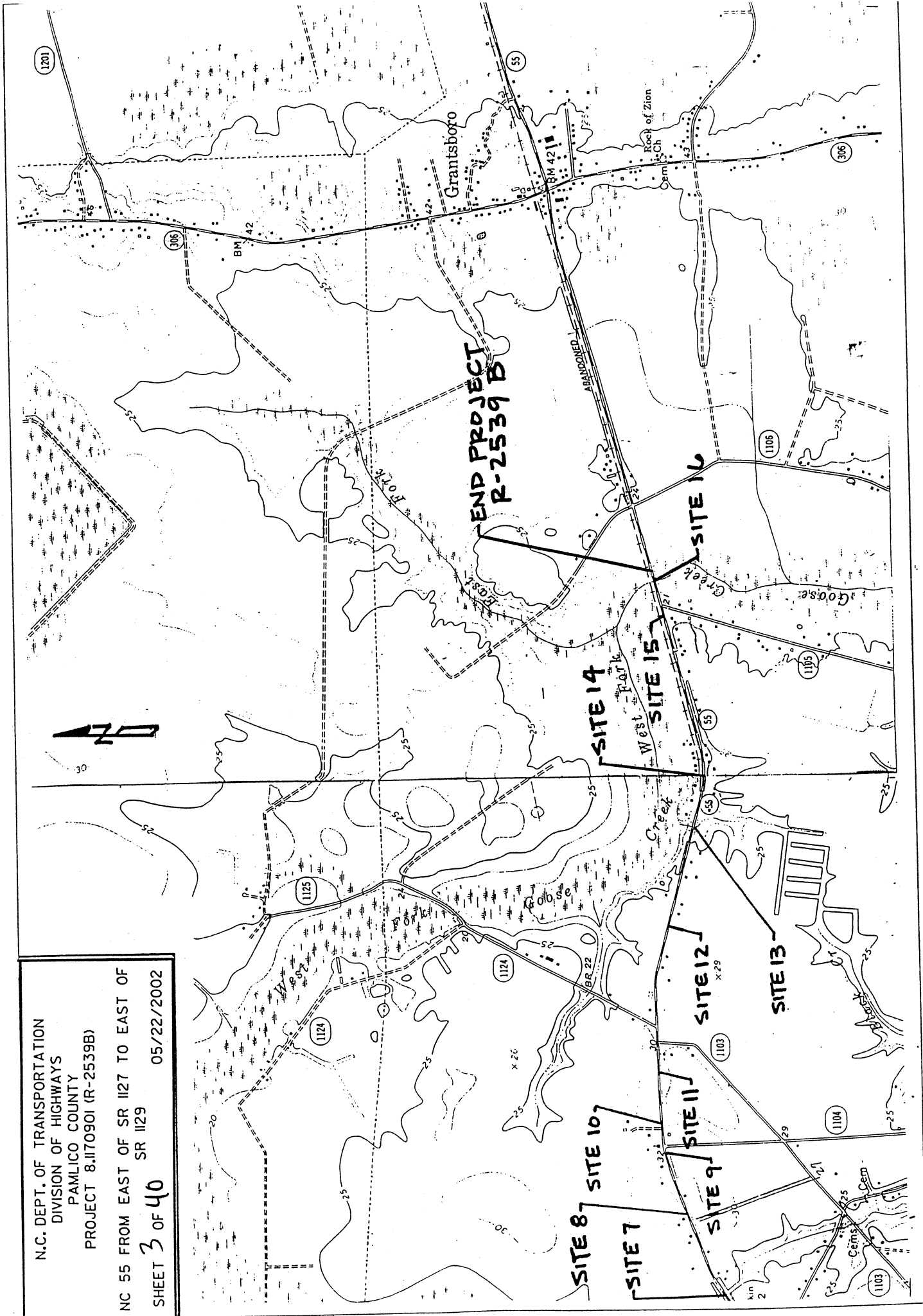
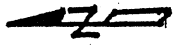

LEGEND

— WLB — WETLAND BOUNDARY

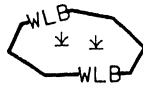
 WETLAND

 DENOTES FILL IN WETLAND

 DENOTES FILL IN SURFACE WATER

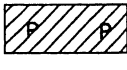
 DENOTES FILL IN SURFACE WATER (POND)

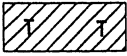
 DENOTES TEMPORARY FILL IN WETLAND

 DENOTES EXCAVATION IN WETLAND

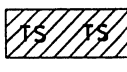
 DENOTES TEMPORARY FILL IN SURFACE WATER

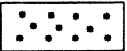
 DENOTES MECHANIZED CLEARING

 DENOTES WETLAND RESTORATION

← ← FLOW DIRECTION

— TB — TOP OF BANK

--- WE --- EDGE OF WATER

— C — PROP. LIMIT OF CUT

— F — PROP. LIMIT OF FILL

—▲— PROP. RIGHT OF WAY

--- NG --- NATURAL GROUND

— PL — PROPERTY LINE

— TOE — TEMP. DRAINAGE EASEMENT

— PDE — PERMANENT DRAINAGE EASEMENT

— EAB — EXIST. ENDANGERED ANIMAL BOUNDARY

— EPB — EXIST. ENDANGERED PLANT BOUNDARY

---▽--- WATER SURFACE

X X X LIVE STAKES
X X

 BOULDER

--- COIR FIBER ROLLS

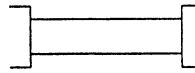

PROPOSED BRIDGE

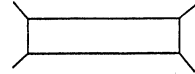

PROPOSED BOX CULVERT



PROPOSED PIPE CULVERT

(DASHED LINES DENOTE EXISTING STRUCTURES)



SINGLE TREE

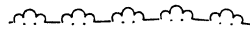

WOODS LINE



DRAINAGE INLET

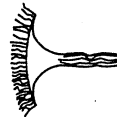

ROOTWAD



RIP RAP



ADJACENT PROPERTY OWNER OR PARCEL NUMBER IF AVAILABLE

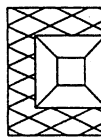

PREFORMED SCOUR HOLE

N. C. DEPT. OF TRANSPORTATION
DIVISION OF HIGHWAYS

PAMILCO COUNTY

PROJECT: 8.1170901 (R-2539B)

NC 55 FROM EAST OF SR 1127 TO EAST OF
SR 1129

SHEET 4 OF 40

07 / 01 / 2002

PROPERTY OWNERS

PARCEL NO.

NAMES

ADDRESSES

PARCEL NO.	NAMES	ADDRESSES
1	JUDY C SPEIGHT	1233 BROAD CREEK RD NEW BERN, NC 28560
2	JULIAN B BROUGHTON, JR.	RT.1, BOX 137B NEW BERN, NC 28560
3	RICHARD DEAN & RONALD HARDISON	6302 HIGHWAY 55 E NEW BERN, NC 28560
4	RAYMOND E DUNN	PO BOX 1389 NEW BERN, NC 28563
5	OSCAR A KRECHEL, JR	4493 HIGHWAY 55 E NEW BERN, NC 28560
6	LESLIE REEL BRINSON, ET AL	PO BOX 56 GRANTSBORO, NC 28529
7	AILEEN S LEE	4849 HIGHWAY 55 E NEW BERN, NC 28560
8	WILLIAM G CAHOON	5025 HIGHWAY 55 E NEW BERN, NC 28560
9	CLARA R BANKS	3058 JANERIO RD ARAPAHOE, NC 28510
10	EVELYN M STEPHENS	5071 HIGHWAY 55 E NEW BERN, NC 28560
11	JOHN C PETERSON	5291 HIGHWAY 55 E NEW BERN, NC 28560
12	ALBERT ROACH	5264 HIGHWAY 55 E NEW BERN, NC 28560
13	MAURICE W BENTON	PO BOX 125 STONEWALL, NC 28583
14	CLAUDIA B ROACH	349 CARMAL DR MELBOURNE, FL 32940
15	ELLEN B JOHNSON	1804 MASHBURN CIRCLE KINSTON, NC 28504
16	D KEITH TYNDALL	6701 HIGHWAY 55 E NEW BERN, NC 28560
17	HOWARD A REEL	7726 HIGHWAY 55 E NEW BERN, NC 28560
18	JERRY CASEY	7389 HIGHWAY 55 E NEW BERN, NC 28560
19	RUBY GOODWIN	7533 HIGHWAY 55 E NEW BERN, NC 28560

N.C. DEPT. OF TRANSPORTATION
DIVISION OF HIGHWAYS

PAMLICO COUNTY
PROJECT 8.1170901 (R-2539B)
NC 55 FROM EAST OF SR 1127 TO EAST OF
SR 1129
SHEET 5 OF 40 05/22/2002

PROPERTY OWNERS

PARCEL NO.	NAMES	ADDRESSES
20	FH REEL JR HEIRS ALLEN K HARKER MYRTIE REEL LEE, HEIRS LESSIE REEL BRINSON	7726 HIGHWAY 55 E NEW BERN, NC 28560
21	ALICE B REEL	PO BOX 128 BRIDGETON, NC 28519
22	CAROLYN L DAVIS	8340 HIGHWAY 55 E NEW BERN, NC 28560
23	JAMES W LEE	3514 COUNTRY CLUB RD MOREHEAD CITY, NC 28557
24	MRS ROY CURTIS	7104 CATLETT ST SPRINGFIELD, VA 22151
25	ELSIE SPIVEY	1822 HIGHWAY 306 N NEW BERN, NC 28560
26	LOTTIE NILES, HEIRS	402 IVY CRESCENT CHESAPEAKE, VA 23325
27	MARY BROWN	PO BOX 1121 NEW BERN, NC 28560
27A	NEHEMIAH WOODARD	8875 HWY. 55 E. NEW BERN, NC 28560
28	BEASLEY FM ACQUISITION GROUP CORP	3033 RIVIERA DR #200 NAPLES, FL 34103
29	RWR LOGGING, INC.	RT. 6 BOX 327-A GOLDSBORO, NC 27530
30	JAMES R KRAUSS	193 BENNETT-TINGLE RD NEW BERN, NC 28560
31	JOHN T HERRING, JR.	810 AIRPORT RD NEW BERN, NC 28560
32	ELIZABETH HARRIS WOZNIAK	300 LEE STREET EMPORIA, VA 23847

N.C. DEPT. OF TRANSPORTATION
DIVISION OF HIGHWAYS

PAMLICO COUNTY
PROJECT 8.1170901 (R-2539B)
NC 55 FROM EAST OF SR 1127 TO EAST OF
SR 1129

SHEET 6 OF 40

05/22/2002

SITE 1 -L- STA. 56 + 30 TO 56 + 55 LT

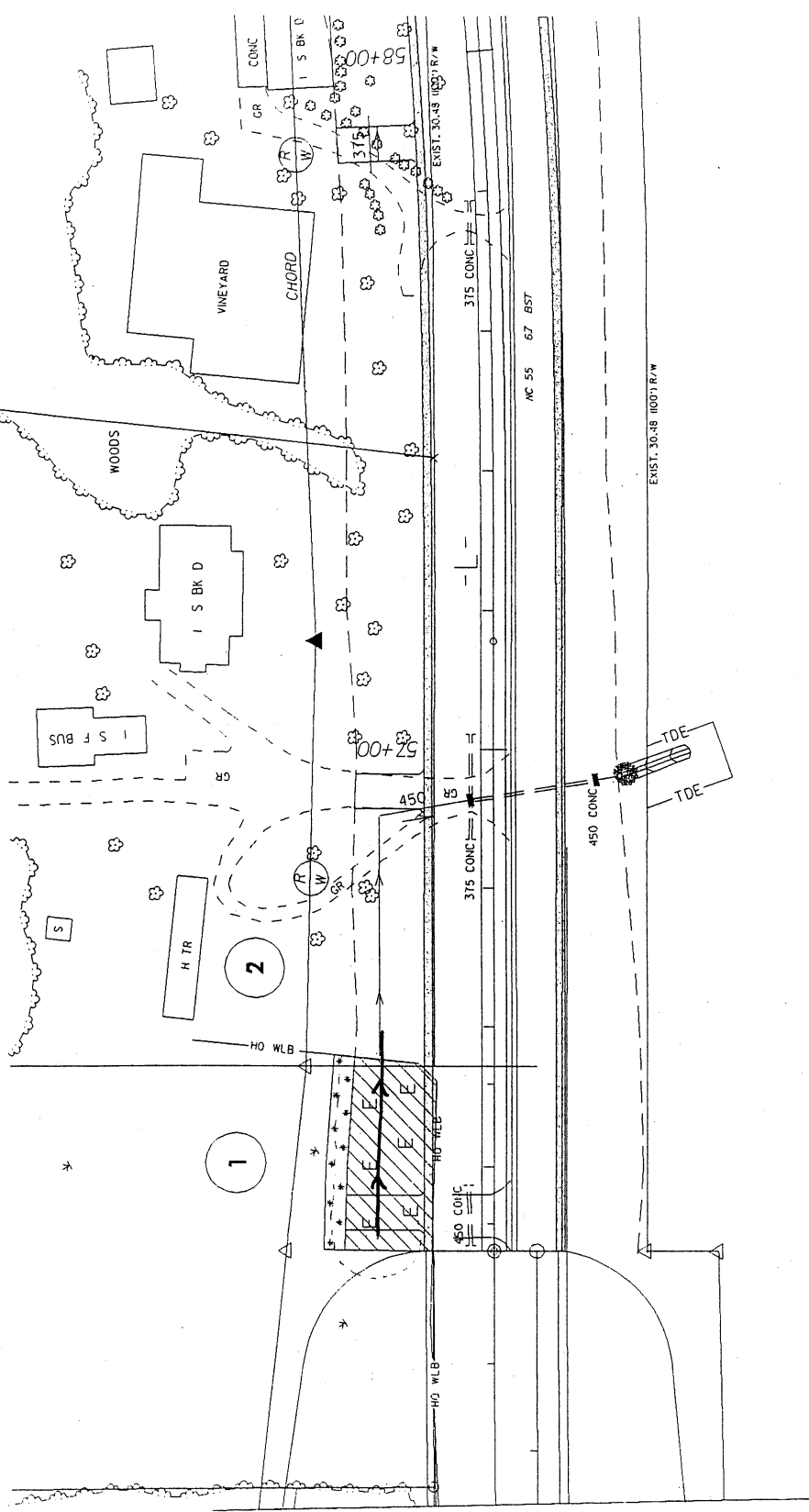

-  DENOTES EXCAVATION IN WETLAND
-  DENOTES MECHANIZED CLEARING

Site 1

N.C. DEPT. OF TRANSPORTATION
DIVISION OF HIGHWAYS

PAMLICO COUNTY



PROJECT 8.1170901 (R-25398)
NC 55 FROM EAST OF SR 1127 TO EAST OF SR 1129

REV. 04/04/03
12/18/2002

SHEET 7 OF 40

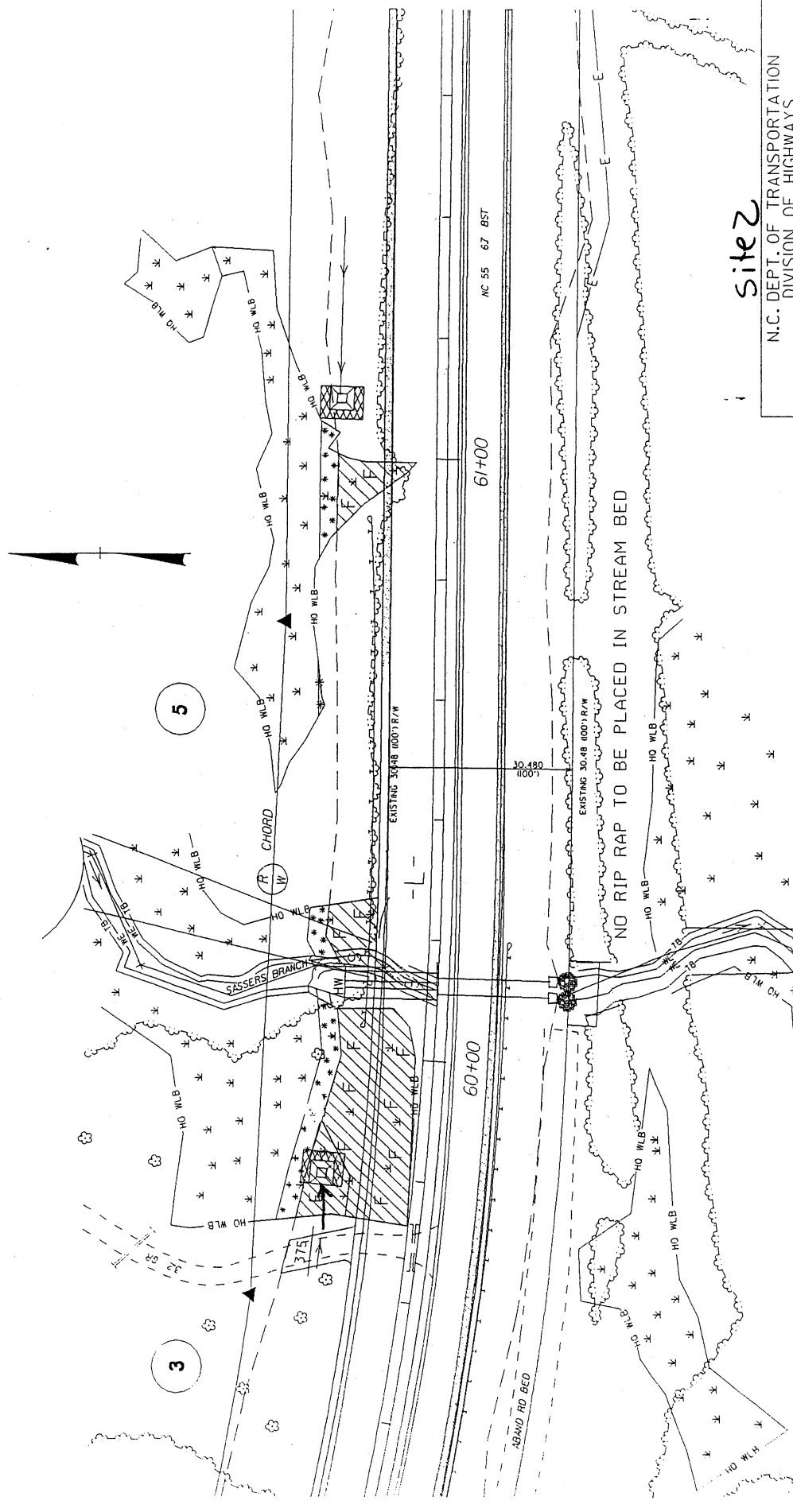
SITE 2 -L- STA. 59+70 TO 61+00 LT

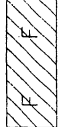

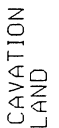
-  DENOTES FILL IN WETLAND
-  DENOTES EXCAVATION IN WETLAND
-  DENOTES FILL IN SURFACE WATER
-  DENOTES MECHANIZED CLEARING

sitez

N.C. DEPT. OF TRANSPORTATION
DIVISION OF HIGHWAYS

PAMLICO COUNTY

PROJECT 8.1170901 (R-2539B)

NC 55 FROM EAST OF SR 1127 TO EAST OF SR 1129

SHEET 8 OF 40
REV. 04/04/03
12/18/2002

SCALE = 1:1000

SITE 5 -L- STA. 62+25 TO 63+60 LT

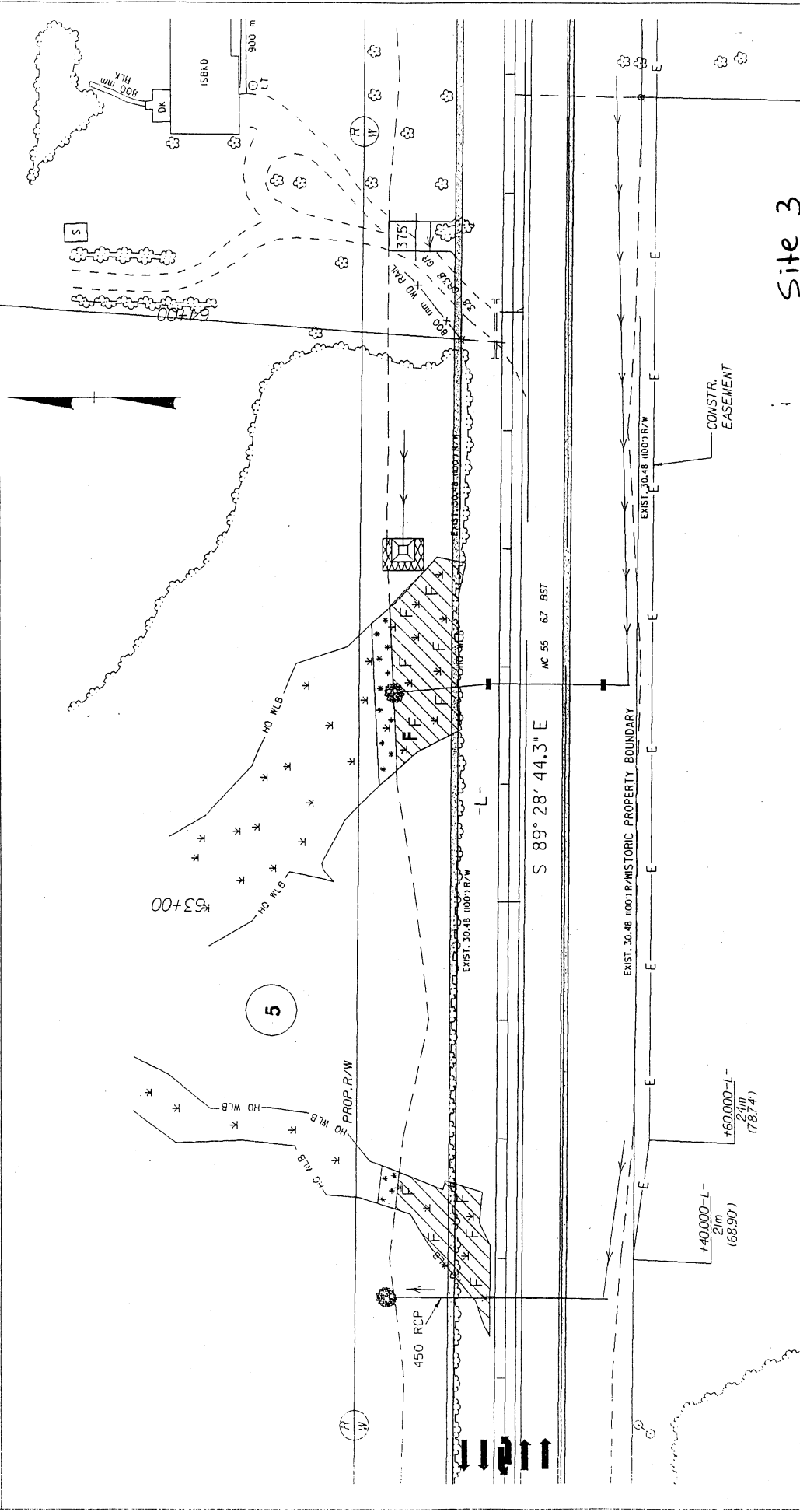

Site 3

N.C. DEPT. OF TRANSPORTATION
DIVISION OF HIGHWAYS

PAMLICO COUNTY

PROJECT 8.II70901 (R-25398)
NC 55 FROM EAST OF SR 1127 TO EAST OF SR 1129

REV. 04/04/03
12/18/2002

Denotes MECHANIZED CLEARING

F F

Denotes FILL IN WETLAND

10
SCALE = 1:10000

SHEET 9 OF 40

SITE 4 -L- STA. 74+85 TO 77+40 RT & LT

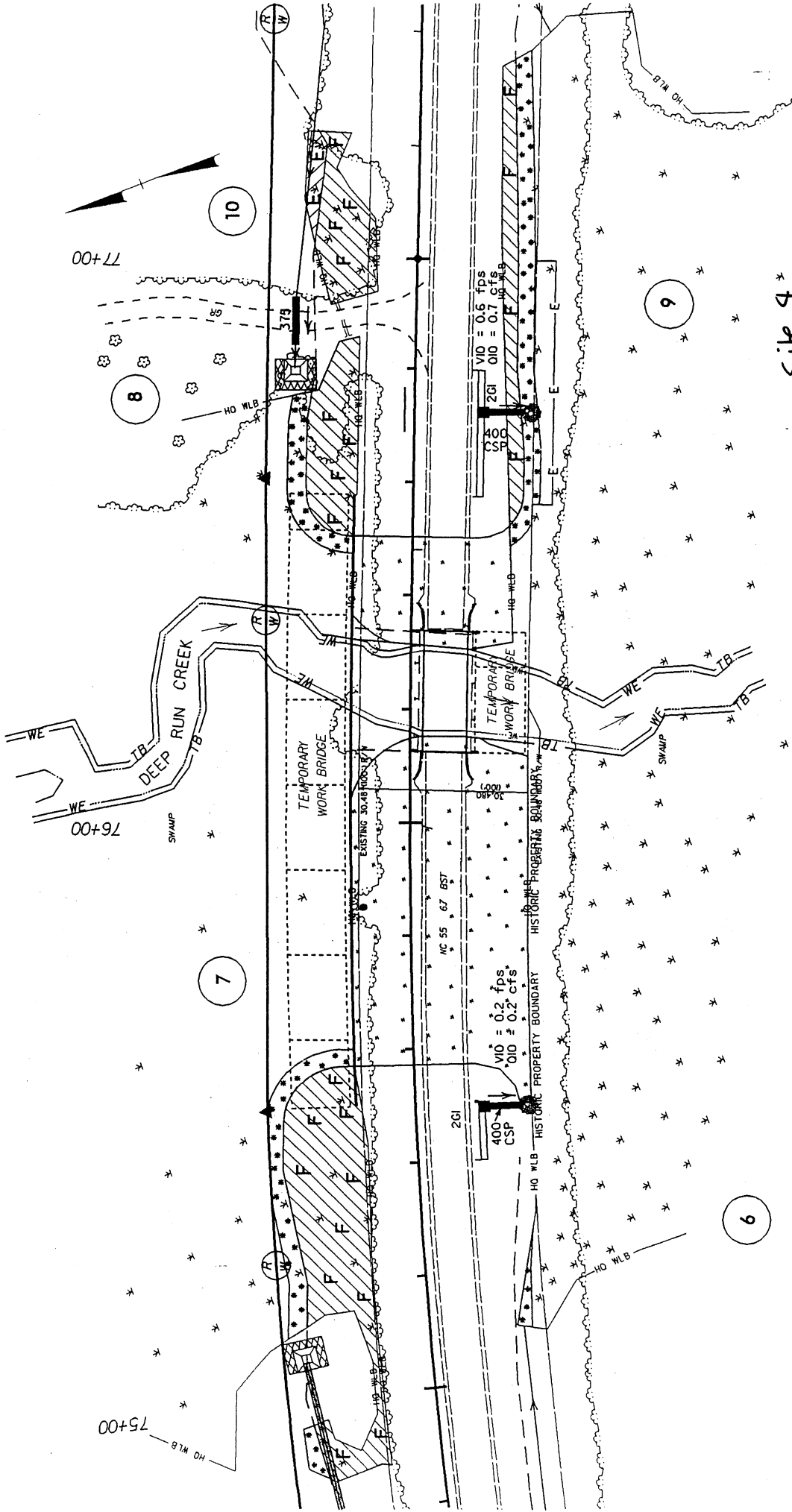

Site 4





N.C. DEPT. OF TRANSPORTATION
DIVISION OF HIGHWAYS

PAMLICO COUNTY

PROJECT 8.I170901 (R-2539B)
NC 55 FROM EAST OF SR 1127 TO EAST OF
SR 1129

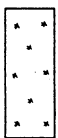
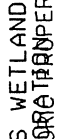
REV. 04/04/03
12/18/2002

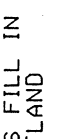
SHEET 10 OF 40

-  DENOTES WETLAND RESTORATION PROPERTY
-  DENOTES EXCAVATION IN WETLAND
-  DENOTES WETLAND
-  DENOTES FILL IN WETLAND
-  DENOTES MECHANIZED CLEARING
-  DENOTES PROPERTY BOUNDARY

SCALE = 1:1000

PI - 75+05.00
 EL - 6.218
 VC - 110m
 G1 - (-)2.604%
 G2 - (-)0.250%

C. PROPOSED BRIDGE
 STA 76+04 -L-
 1143mm PRESTRESSED
 CONCRETE GIRDERS
 5 SPANS @ 20m
 SKEW - 90° G.P. EL - 5.971

PI - 77+24.00
 EL - 5.671
 VC - 125m
 G1 - (-)0.250%
 G2 - (+)2.449%

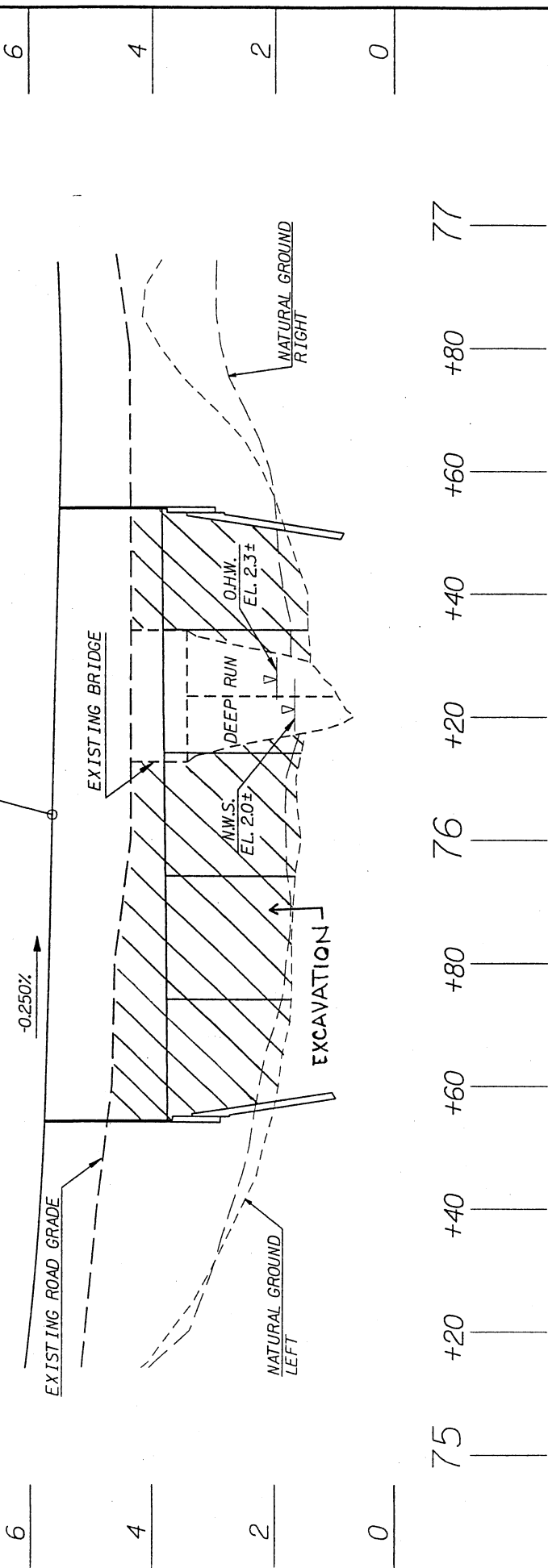

PROFILE SITE 4

N.C. DEPT. OF TRANSPORTATION
 DIVISION OF HIGHWAYS

PAMLICO COUNTY

PROJECT: 8.1170901 (R-2539B)

NC 55 FROM EAST OF SR 1127 TO
 EAST OF SR 1129

SHEET 11 OF 46 05 / 22 / 02

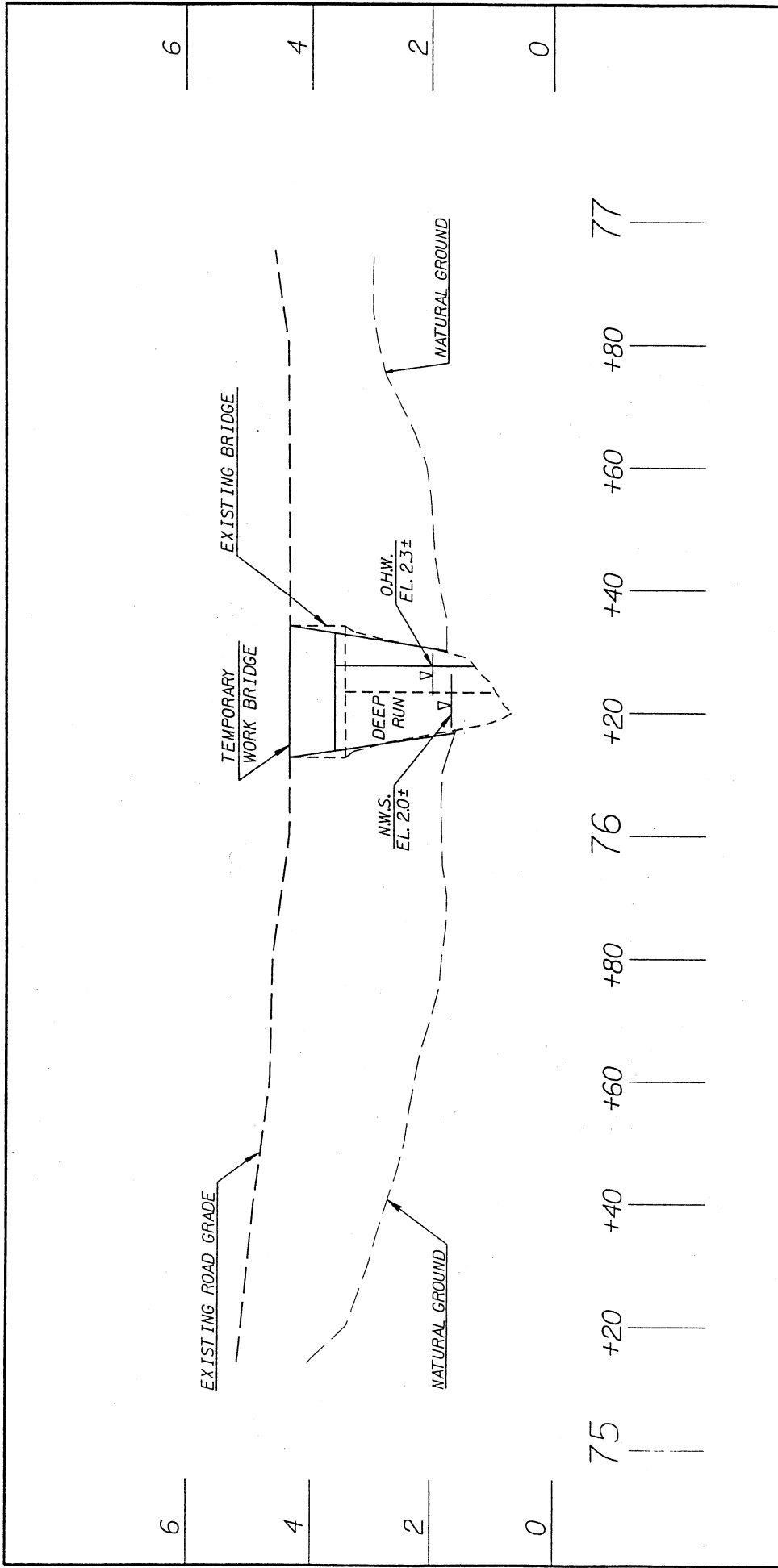

**TEMPORARY
 WORK BRIDGE
 (SOUTH SIDE)
 PROFILE
 SITE 4**

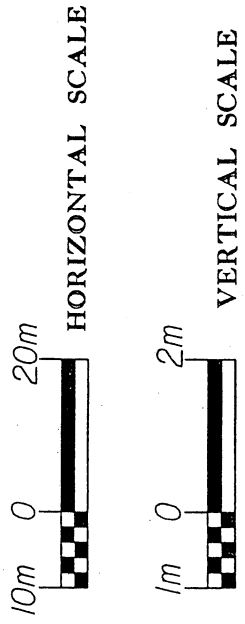

N.C. DEPT. OF TRANSPORTATION
 DIVISION OF HIGHWAYS
 PAMLICO COUNTY
 PROJECT: 8.1170901 (R-2539B)
 NC 55 FROM EAST OF SR 1127 TO
 EAST OF SR 1129
SHEET 12 OF 40 05 / 22 / 02

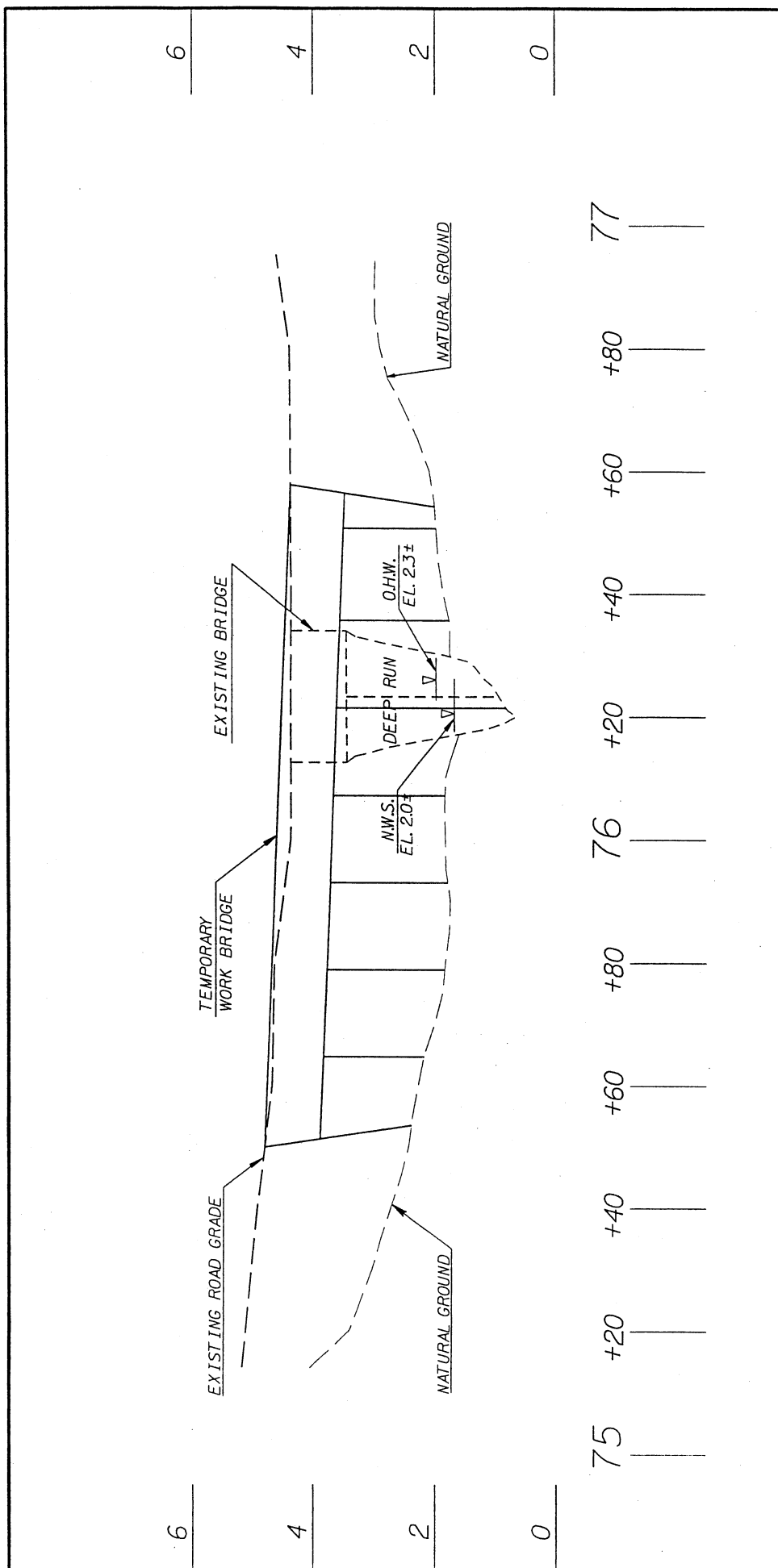

TEMPORARY
WORK BRIDGE
(NORTH SIDE)
PROFILE
SITE 4

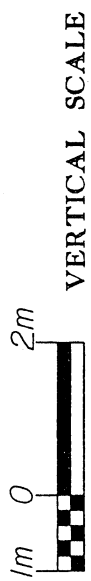

N.C. DEPT. OF TRANSPORTATION
DIVISION OF HIGHWAYS
PAMLICO COUNTY
PROJECT: 8.1170901 (R-2539B)
NC 55 FROM EAST OF SR 1127 TO
EAST OF SR 1129
SHEET 13 OF 40 05 / 22 / 02

TYPICAL SECTION OF NEW ROADWAY
FROM 74+85 TO BEGIN BRIDGE AND FROM END OF BRIDGE TO 77+40

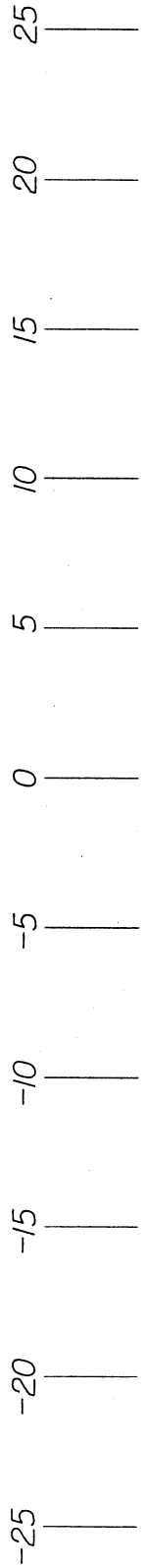
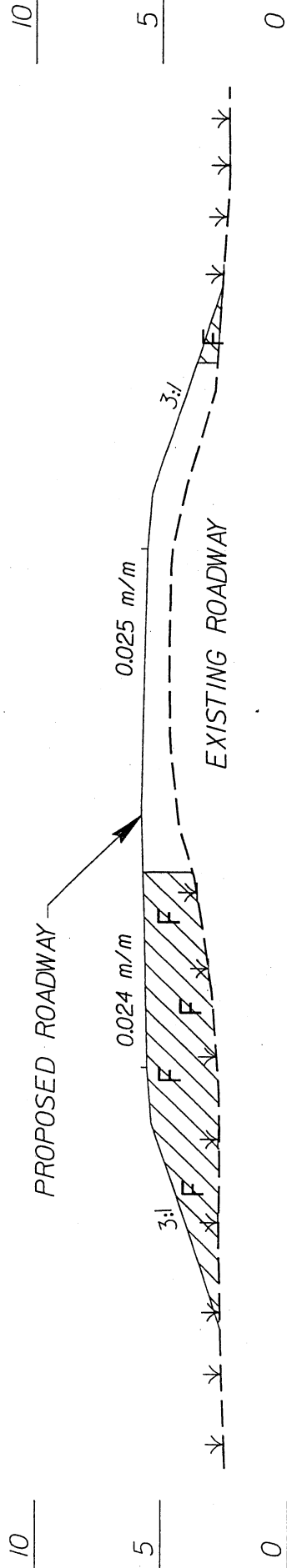

SECTION VIEW
SITE 4

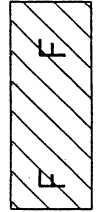
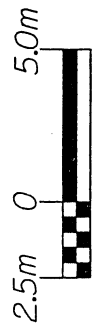

DENOTES FILL IN
WETLAND

N.C. DEPT. OF TRANSPORTATION
DIVISION OF HIGHWAYS

PAMLICO COUNTY

PROJECT: 8.1170901 (R-2539B)



NC 55 FROM EAST OF SR 1127 TO
EAST OF SR 1129

SHEET 14 OF 40

05 / 22 / 02

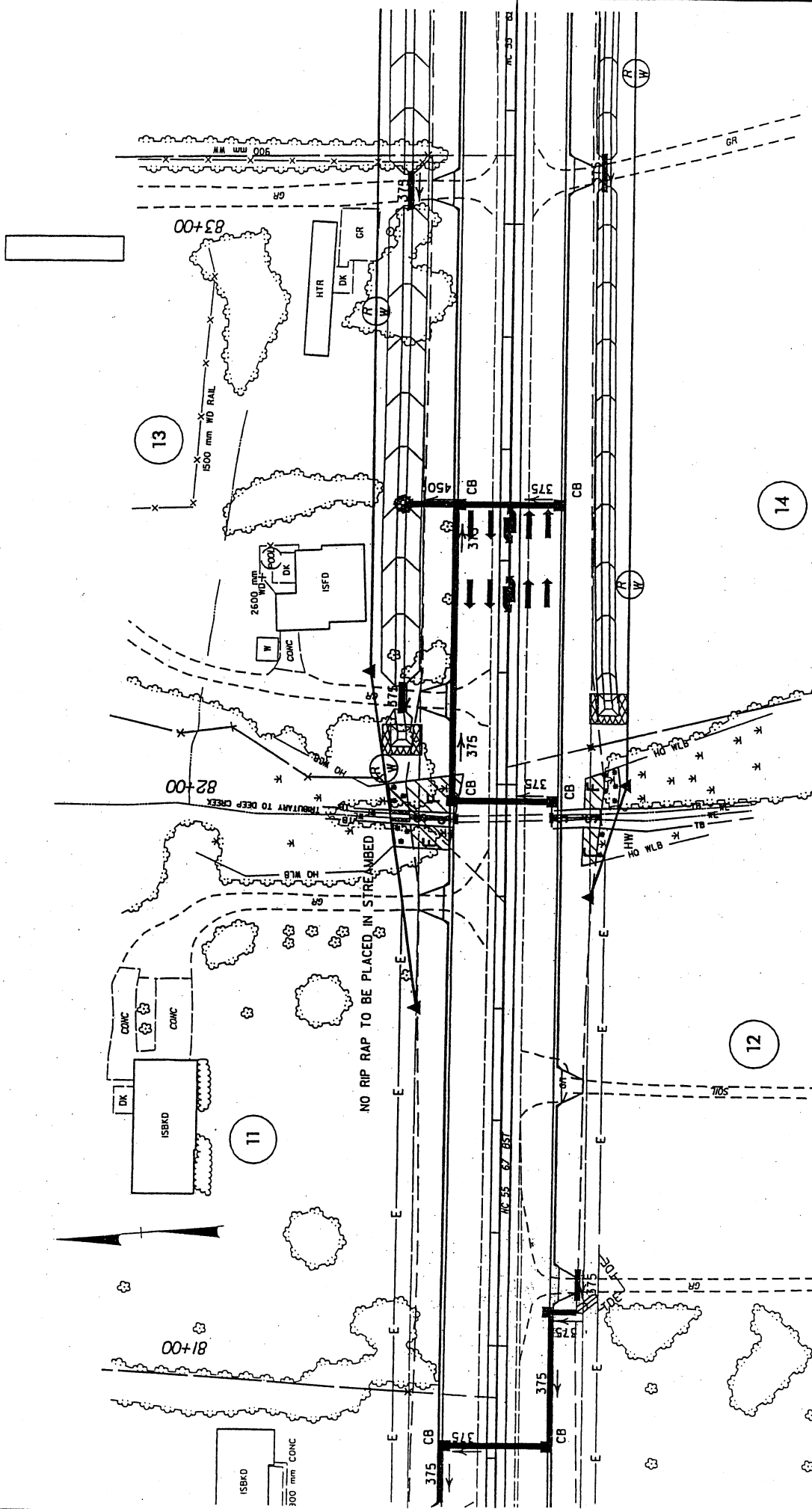
SITE 5 -L- STA. 81+85 TO 82+00 RT & LT



-  DENOTES FILL IN WETLAND
-  DENOTES FILL IN SURFACE WATER
-  DENOTES MECHANIZED CLEARING

RECEIVED
OCT 08 2003
DIV. OF COASTAL MANAGEMENT
RALEIGH

N.C. DEPT. OF TRANSPORTATION
DIVISION OF HIGHWAYS
PAMLICO COUNTY
PROJECT 8.1170901 (R-2539B)
NC 55 FROM EAST OF SR 1127 TO EAST OF SR 1129

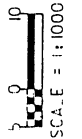

SITE 6 -L- STA. 102+35 TO 103+65 RT & LT

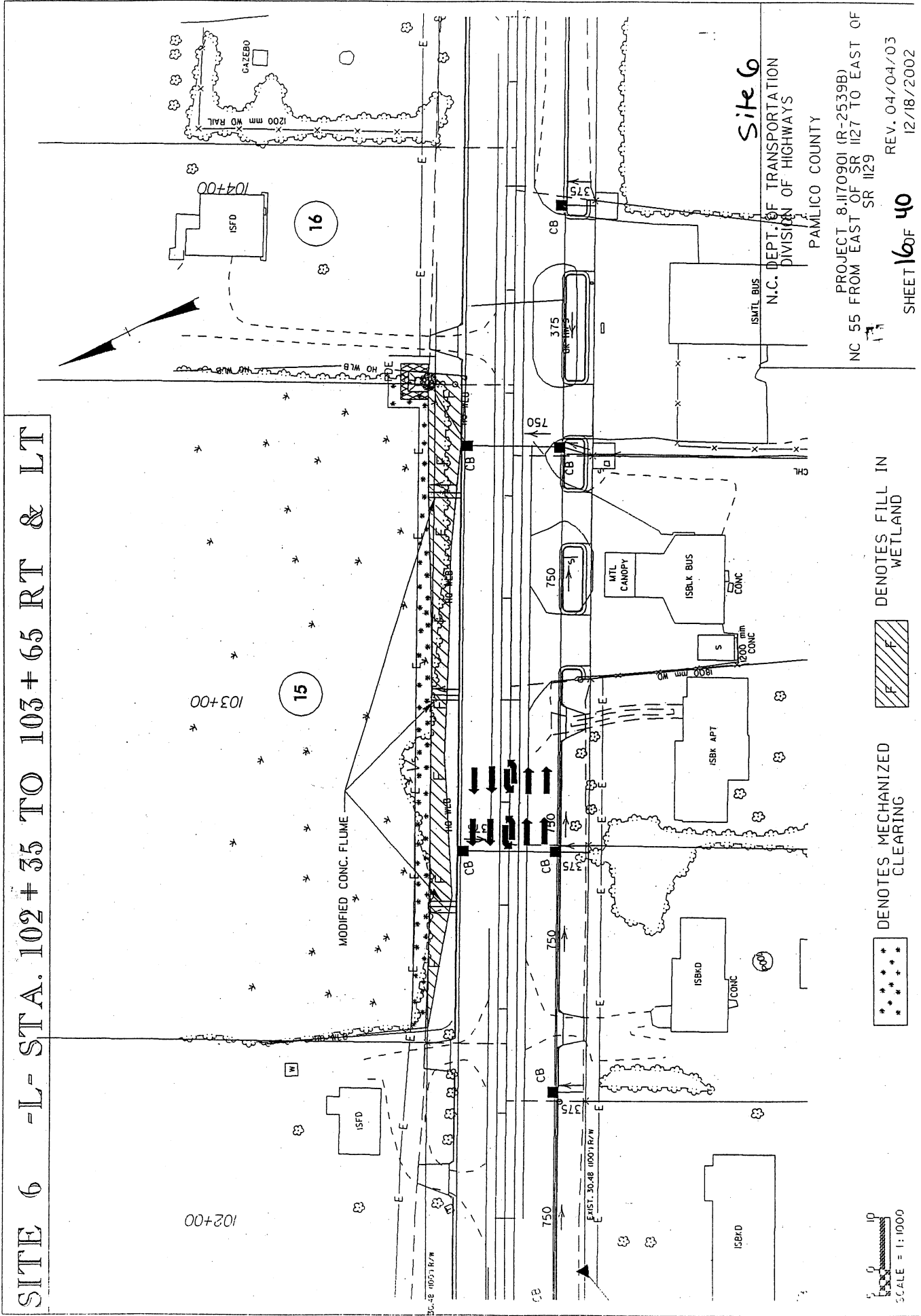

Site 6

N.C. DEPT. OF TRANSPORTATION
DIVISION OF HIGHWAYS

PAMLICO COUNTY

PROJECT 8.1170901 (R-2539B)
NC 55 FROM EAST OF SR 1127 TO EAST OF
SR 1129

SHEET 16 OF 40
REV. 04/04/03
12/18/2002

DENOTES FILL IN
WETLAND

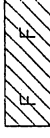

DENOTES MECHANIZED
CLEARING



SCALE = 1:1000

SITE 7 -L- STA. 108+50 TO 110+50 RT & LT

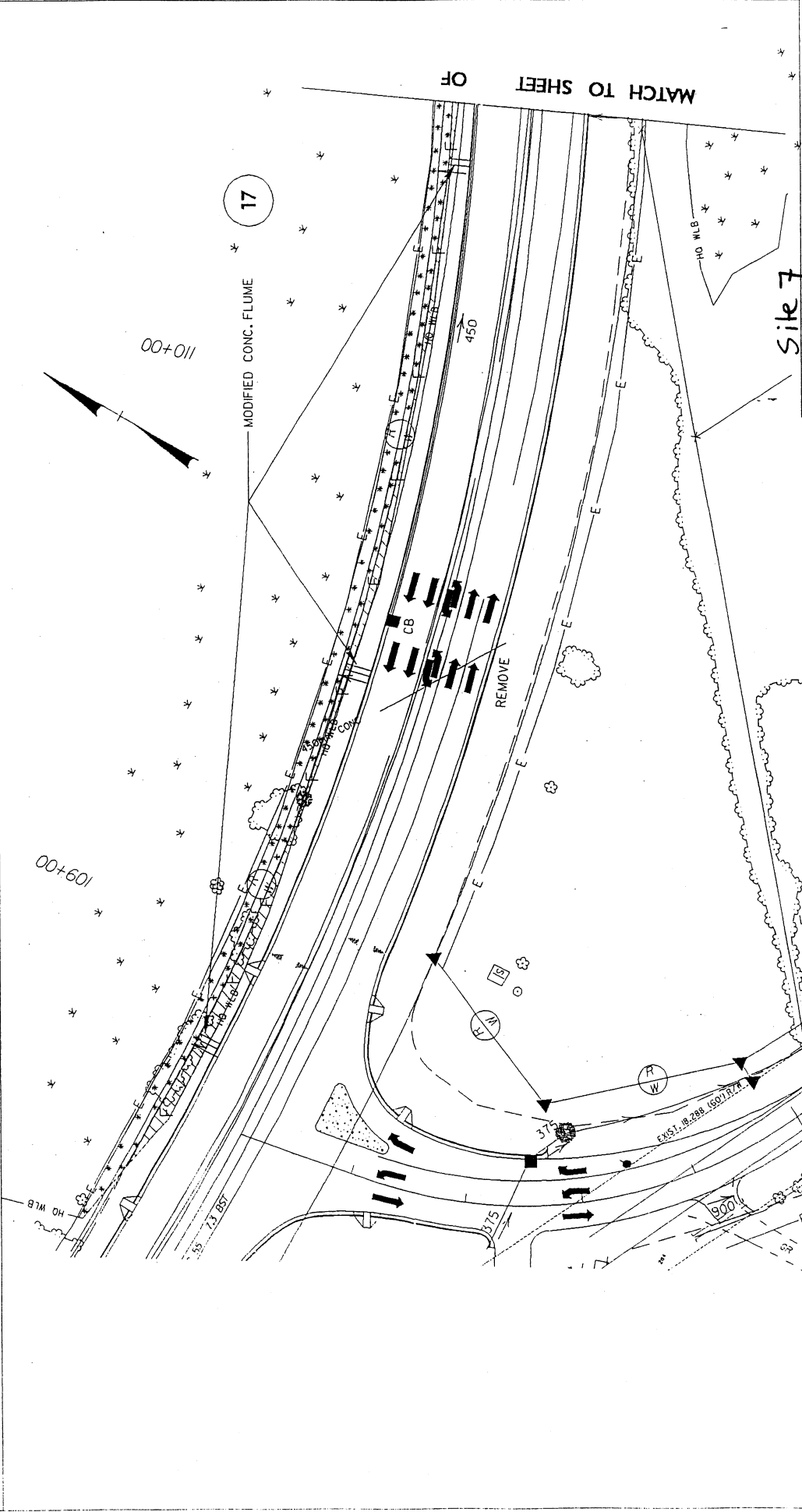

N.C. DEPT. OF TRANSPORTATION
 DIVISION OF HIGHWAYS
 PAMLICO COUNTY
 PROJECT 8.1170901 (R-2539B)
 FROM EAST OF SR 1127 TO EAST OF
 SR 1129
 REV. 04/04/03
 12/18/2002

DENOTES FILL IN
 WETLAND
 DENOTES MECHANIZED
 CLEARING

SCALE = 1:1000

SITE 7 -L- STA. 110+50 TO 112+30 RT & LT

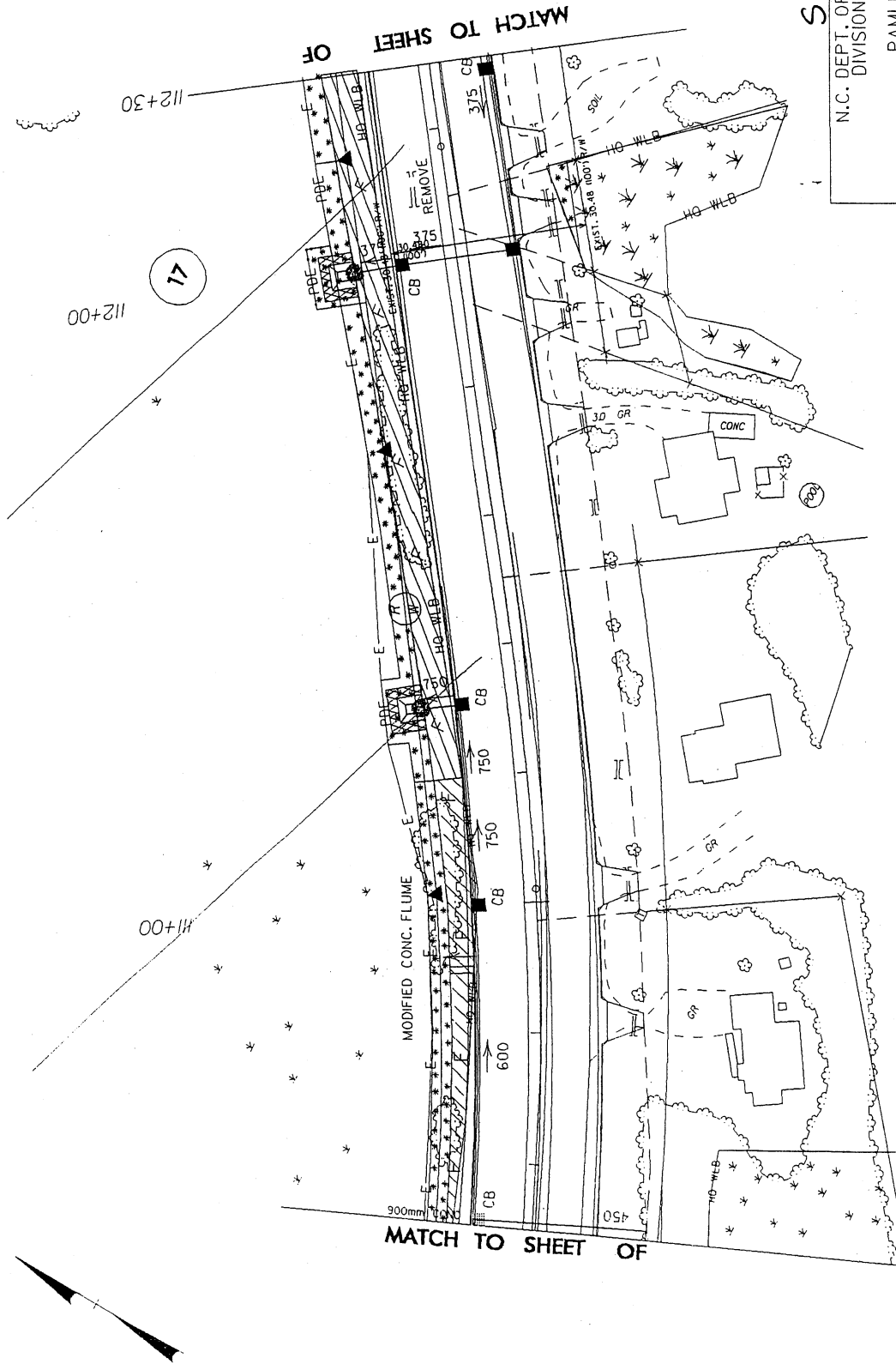

Site 7

N.C. DEPT. OF TRANSPORTATION
DIVISION OF HIGHWAYS

PAMLICO COUNTY

PROJECT 8-I170901 (R-2539B)
NC 55 FROM EAST OF SR 1127 TO EAST OF
SR 1129

REV. 04/04/03
12/18/2002

SHEET 10 OF 40

*** * DENOTES MECHANIZED
CLEARING

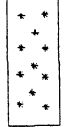

*** ** DENOTES FILL IN
WETLAND

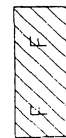

SCALE = 1:1000

SITE 7 -L- STA. 108+50 TO 114+00 RT & LT

RECEIVED

OCT 29 2003

DIV. OF COASTAL MANAGEMENT,
RALEIGH

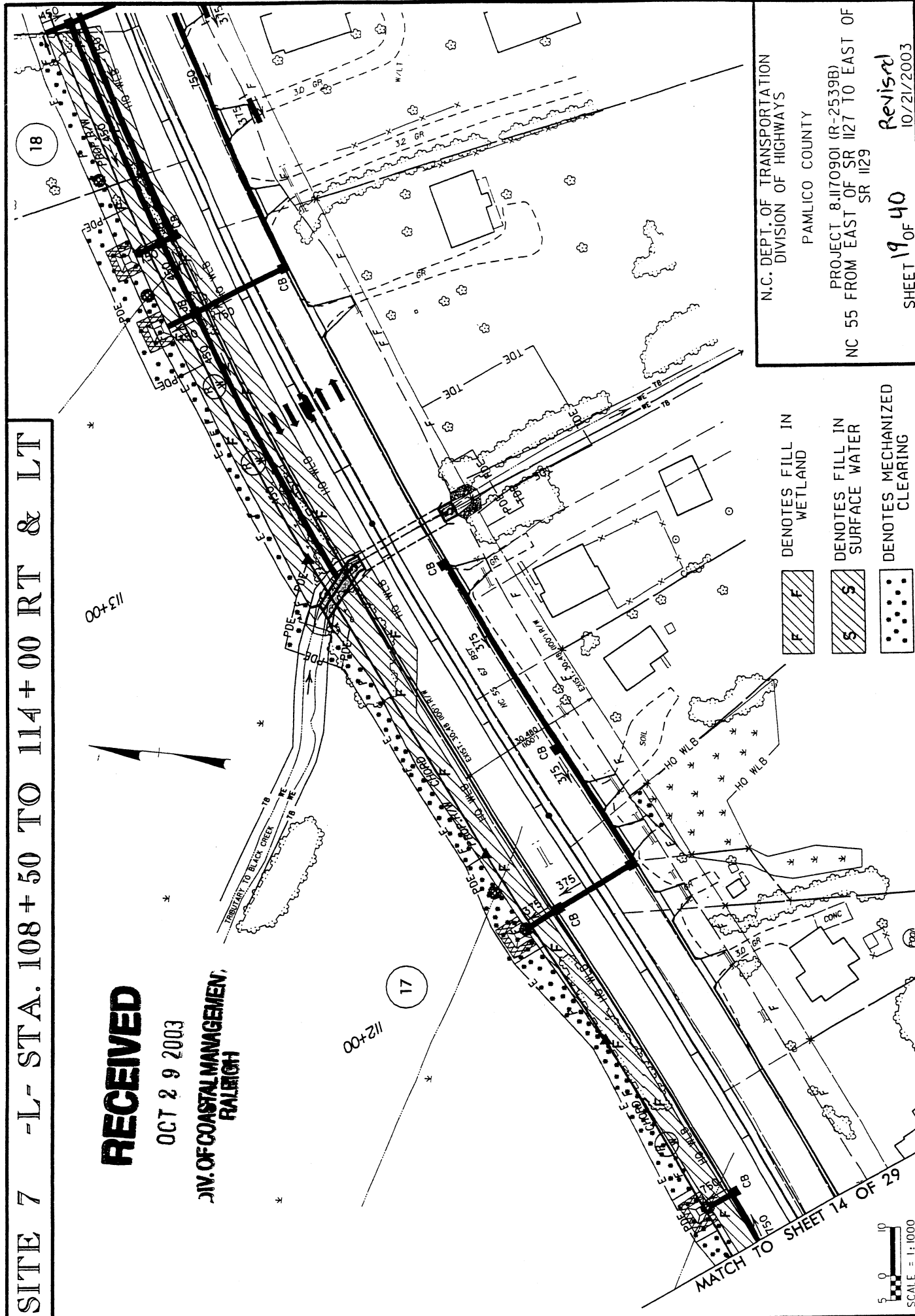

- DENOTES FILL IN WETLAND
- DENOTES FILL IN SURFACE WATER
- DENOTES MECHANIZED CLEARING

N.C. DEPT. OF TRANSPORTATION
DIVISION OF HIGHWAYS
PAMLICO COUNTY
PROJECT 8.1170901 (R-2539B)
NC 55 FROM EAST OF SR 1127 TO EAST OF SR 1129

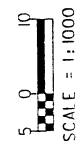

SHEET 19 OF 40

Revised
10/21/2003

(2 of 2)

MATCH TO SHEET 14 OF 29

SITE 7 -L- STA. 112+30 TO 114+00 RT & LT

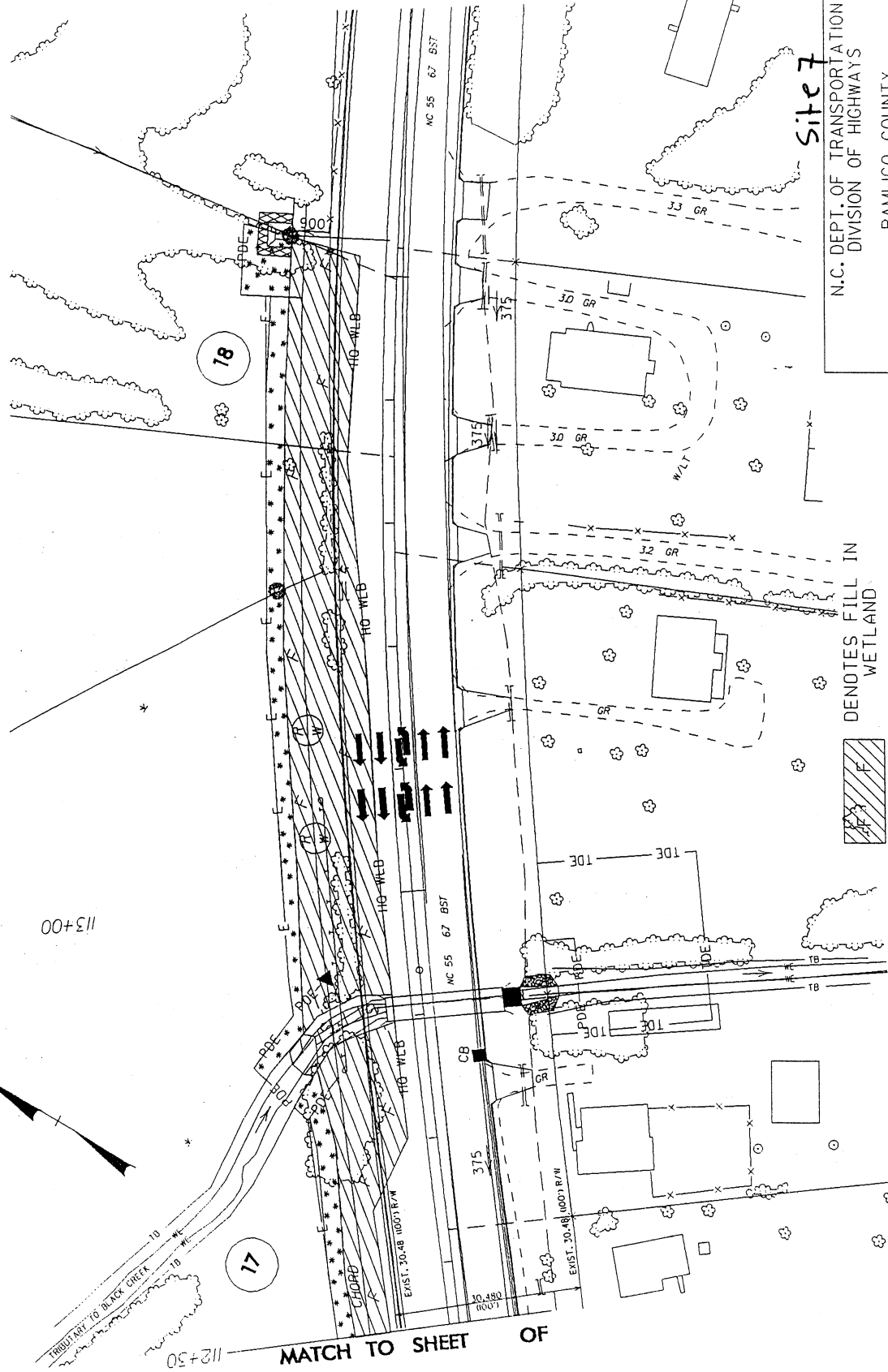

Site 7

N.C. DEPT. OF TRANSPORTATION
DIVISION OF HIGHWAYS
PAMLICO COUNTY
PROJECT 8.1170901 (R-2539B)
FROM EAST OF SR 1127 TO EAST OF
SR 1129
REV. 04/04/03
12/18/2002

- [Symbol: Diagonal lines /] DENOTES FILL IN WETLAND
- [Symbol: Diagonal lines \] DENOTES FILL IN SURFACE WATER
- [Symbol: Asterisks *] DENOTES MECHANIZED CLEARING

SCALE = 1:1000

PI = 113+00.000
 EL = 9.417 m
 VC = 170 m

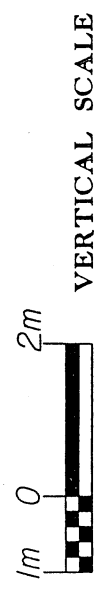
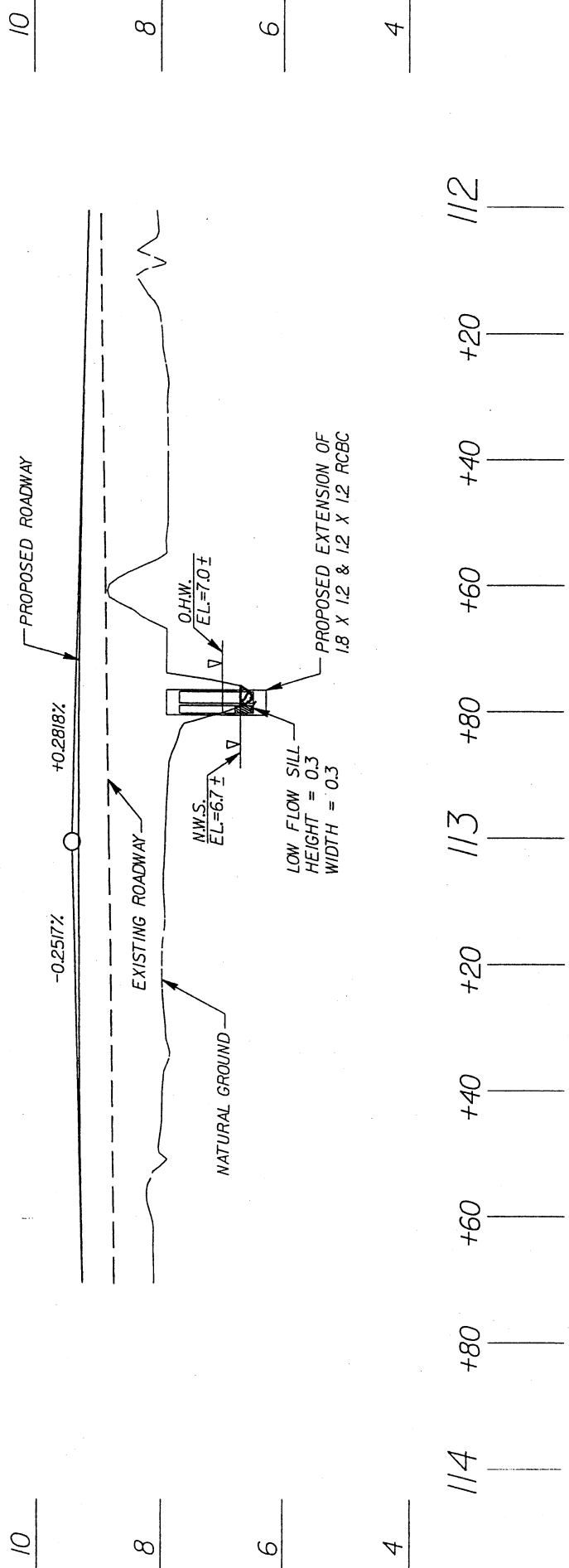

PROFILE SITE 7

 DENOTES FILL IN SURFACE WATER

N.C. DEPT. OF TRANSPORTATION
 DIVISION OF HIGHWAYS
 PAMLICO COUNTY
 PROJECT: 8.1170901 (R-2539B)
 NC 55 FROM EAST OF SR 1127 TO
 EAST OF SR 1129
 SHEET 20 OF 40 05/22/02

TYPICAL SECTION OF NEW ROADWAY
FROM 108+50 TO 114+00

15

15

10

10

5

5

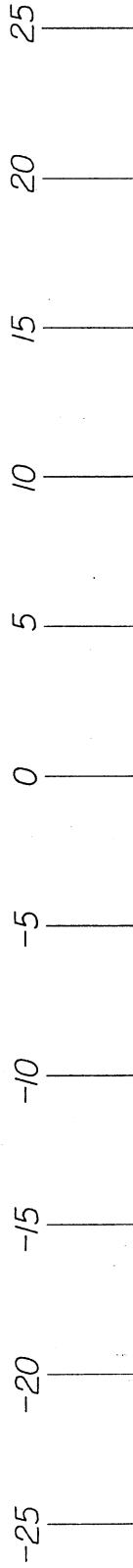
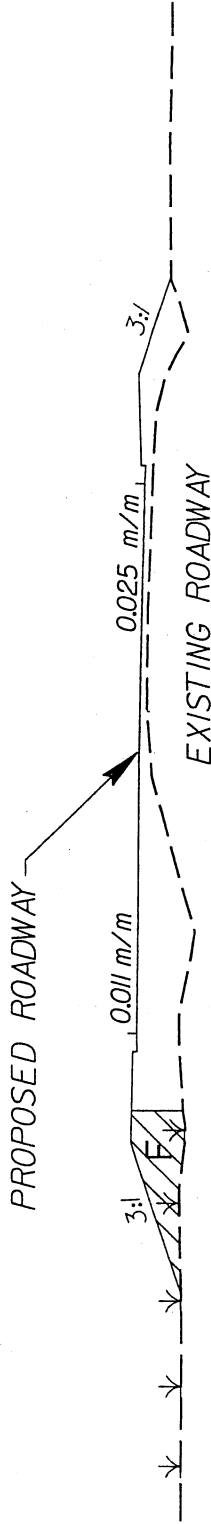

SECTION VIEW
SITE 7

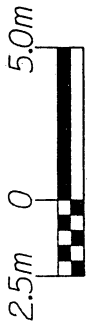

 DENOTES FILL IN WETLAND

N.C. DEPT. OF TRANSPORTATION
DIVISION OF HIGHWAYS

PAMLICO COUNTY

PROJECT: 8.1170901 (R-2539B)

NC 55 FROM EAST OF SR 1127 TO
EAST OF SR 1129

SHEET 21 OF 40

05/22/02

SITE 8 -L- STA. 117+20 TO 118+60 LT

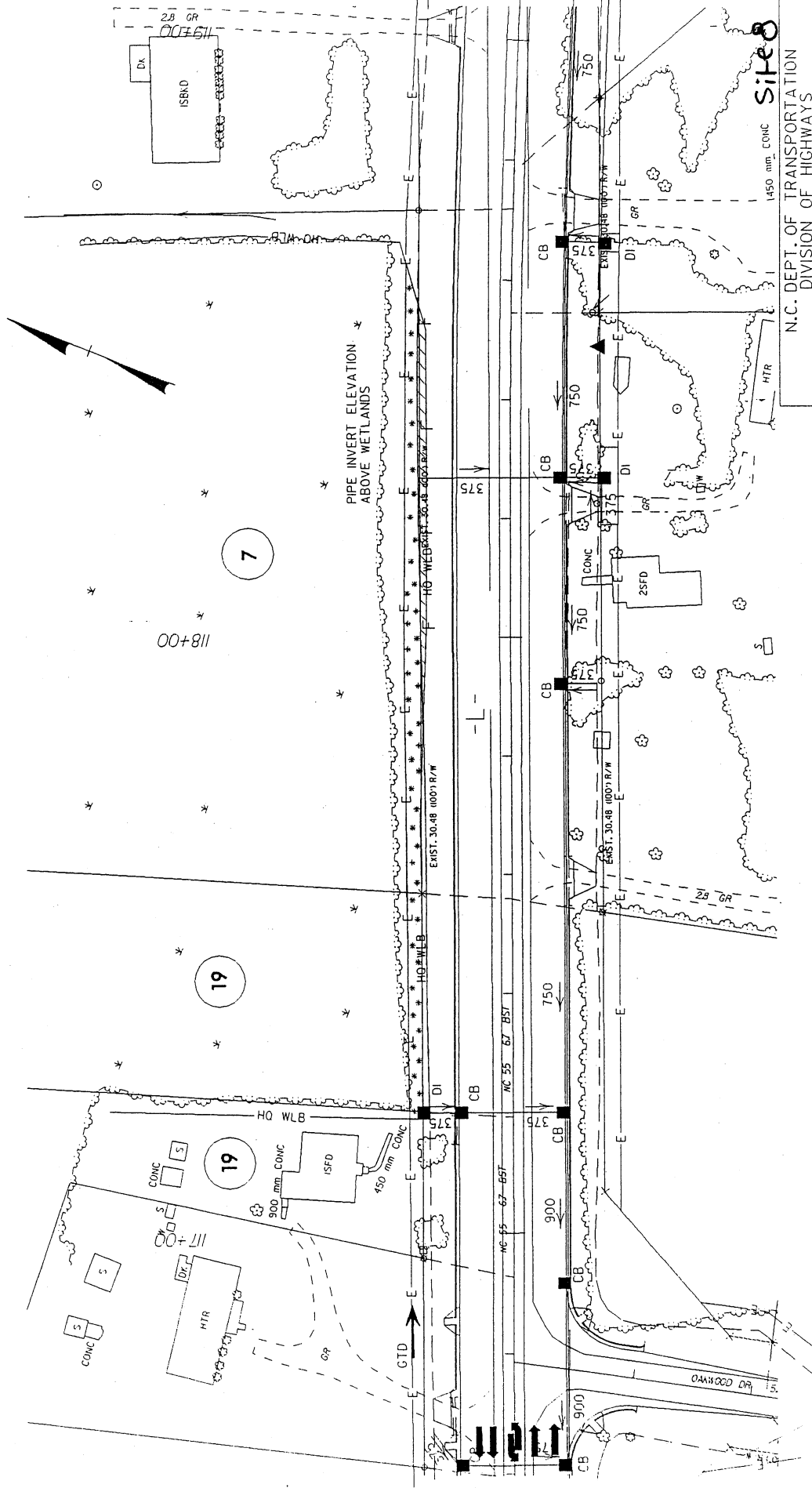

PIPE INVERT ELEVATION ABOVE WETLANDS

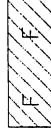
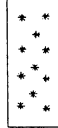
-  DENOTES FILL IN WETLAND
-  DENOTES MECHANIZED CLEARING

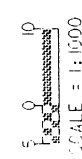

PAMLICO COUNTY
 N.C. DEPT. OF TRANSPORTATION
 DIVISION OF HIGHWAYS
 PROJECT 8.1170901 (R-2539B)
 NC 55 FROM EAST OF SR 1127 TO EAST OF SR 1129
 SR 1129
 REV. 04/04/03
 12/18/2002
SHEET 22 of 40

Site 8

SITE 9 -L- STA. 119+20 TO 120+20 RT

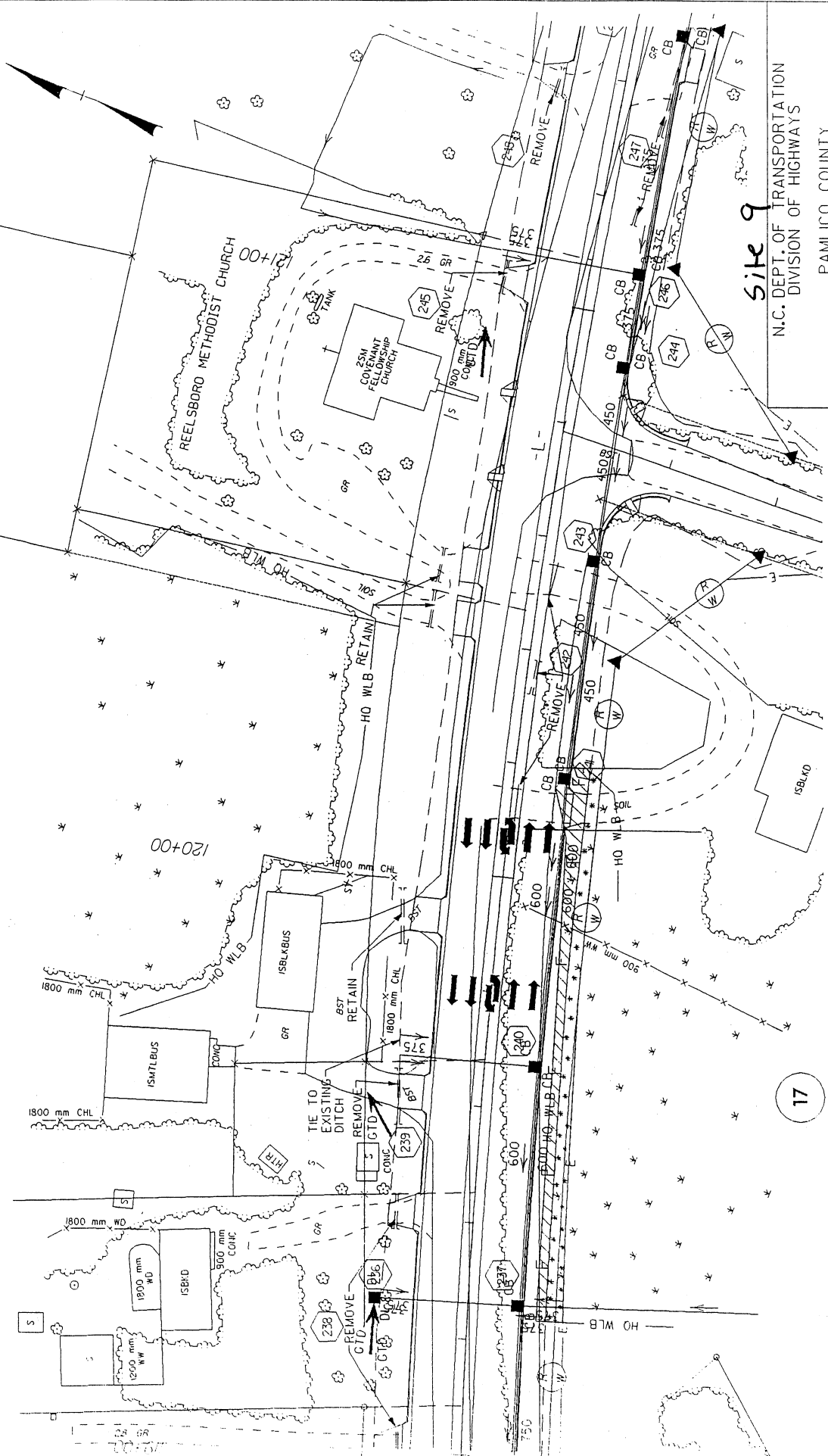

17

Site 9

N.C. DEPT. OF TRANSPORTATION
DIVISION OF HIGHWAYS
FAMLICO COUNTY

PROJECT 8.II7090I (R-2539B)
NC 55 FROM EAST OF SR 1127 TO EAST OF SR 1129

SHEET 23 OF 40
REV. 04/04/03
12/18/2002

***** DENOTES MECHANIZED CLEARING

▨ DENOTES FILL IN WETLAND

SCALE = 1:1000

SITE 10 -L- STA. 121+70 TO 122+20 LT

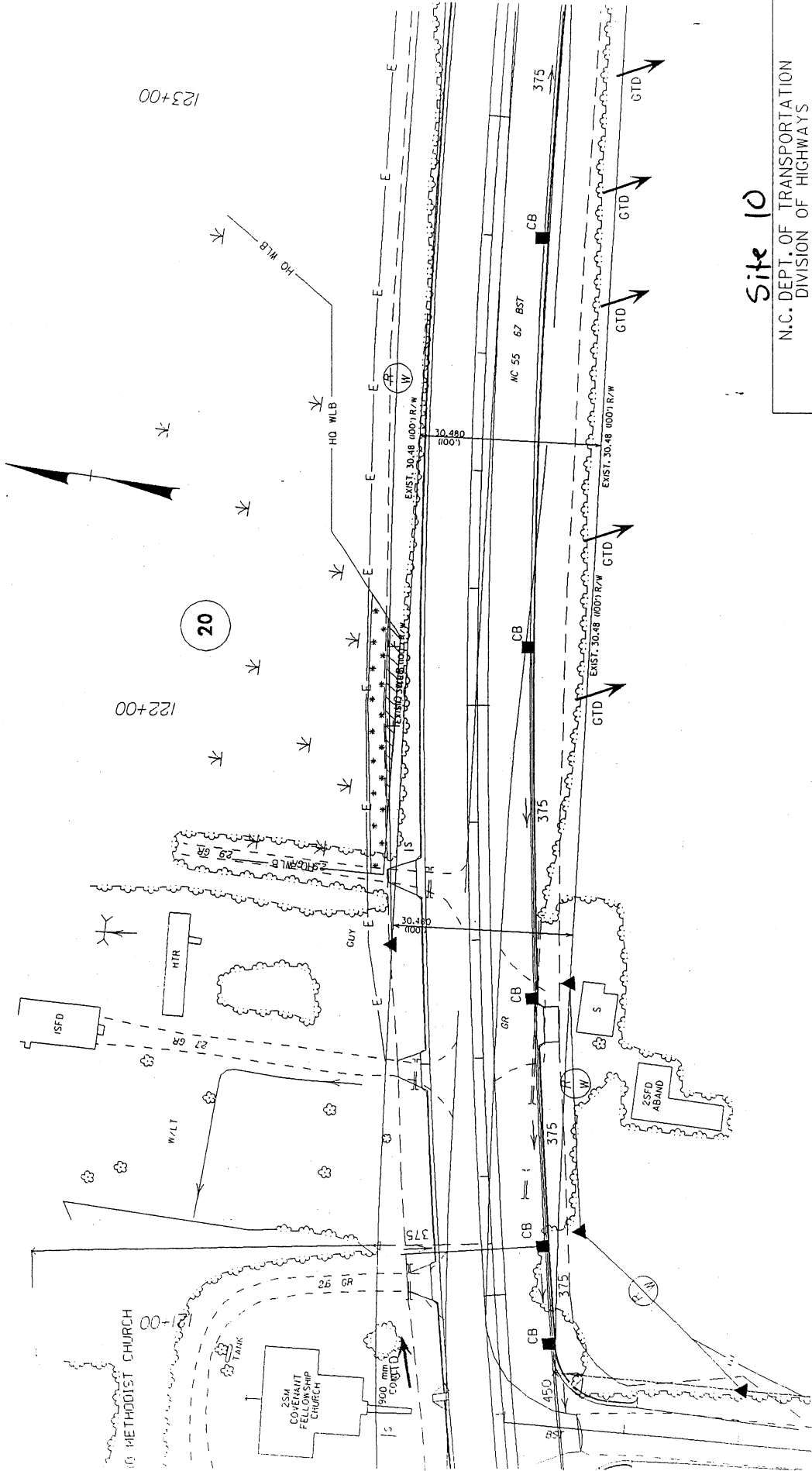

Site 10

N.C. DEPT. OF TRANSPORTATION
DIVISION OF HIGHWAYS

FAMLICO COUNTY

PROJECT 8.II7090I (R-2539B)
FROM EAST OF SR 1127 TO EAST OF
SR 1129

REV. 04/04/03
12/18/2002

SHEET 27 OF 40

***** DENOTES MECHANIZED CLEARING

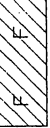

***** DENOTES FILL IN WETLAND

0 10
SCALE = 1:1000

SITE 11 -L- STA. 123+75 TO 125+60 RT & LT

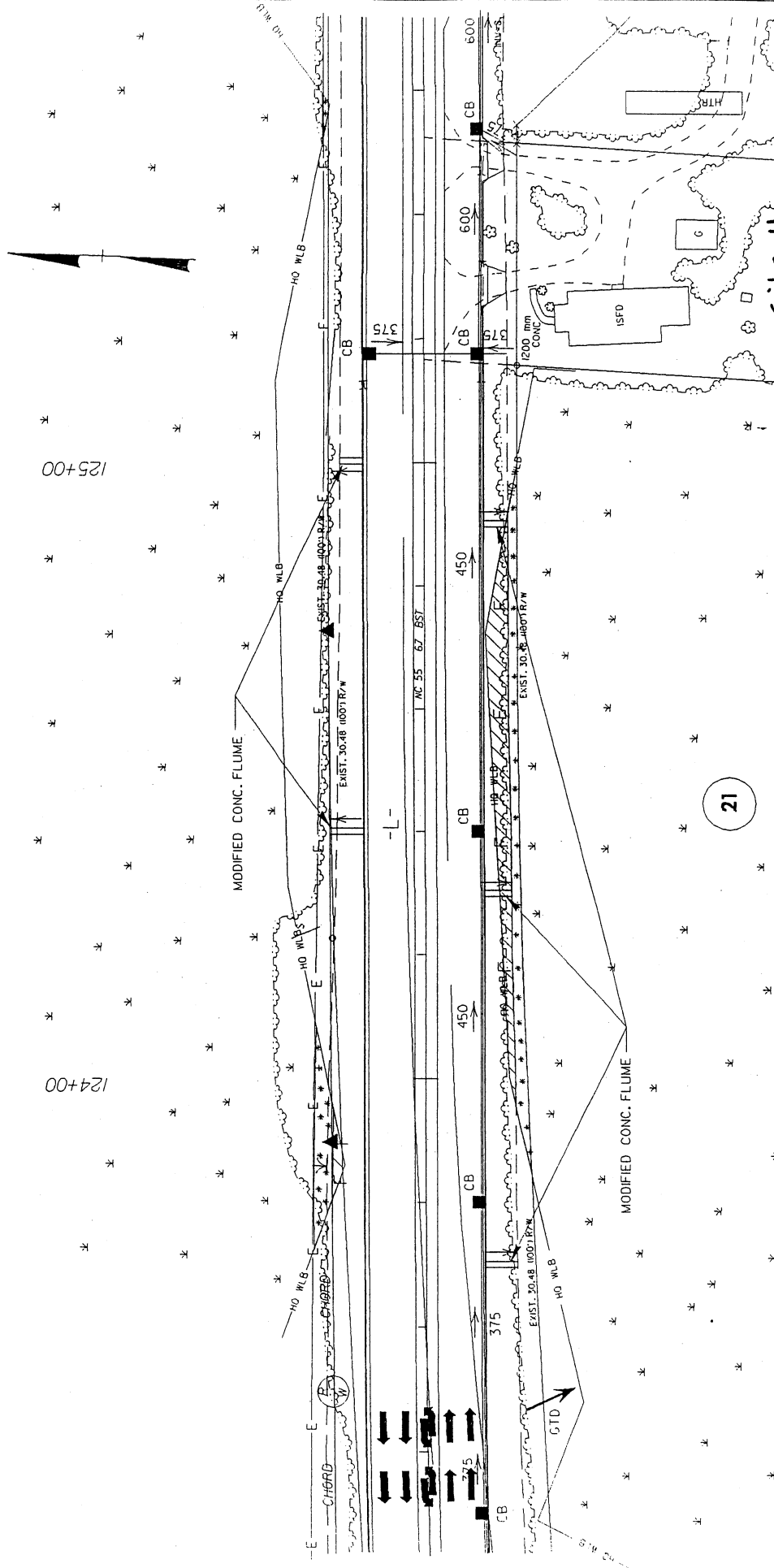

N.C. DEPT. OF TRANSPORTATION
 DIVISION OF HIGHWAYS
 PAMLICO COUNTY
 PROJECT 8J170901 (R-2539B)
 NC-55 FROM EAST OF SR 1127 TO EAST OF
 SR 1129
 REV. 04/04/03
 12/18/2002

21

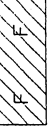

 DENOTES MECHANIZED
 CLEARING



SCALE = 1:1000

SHEET 25 OF 40

SITE 13 -L- STA. 134+75
TO 137+30 RT & LT

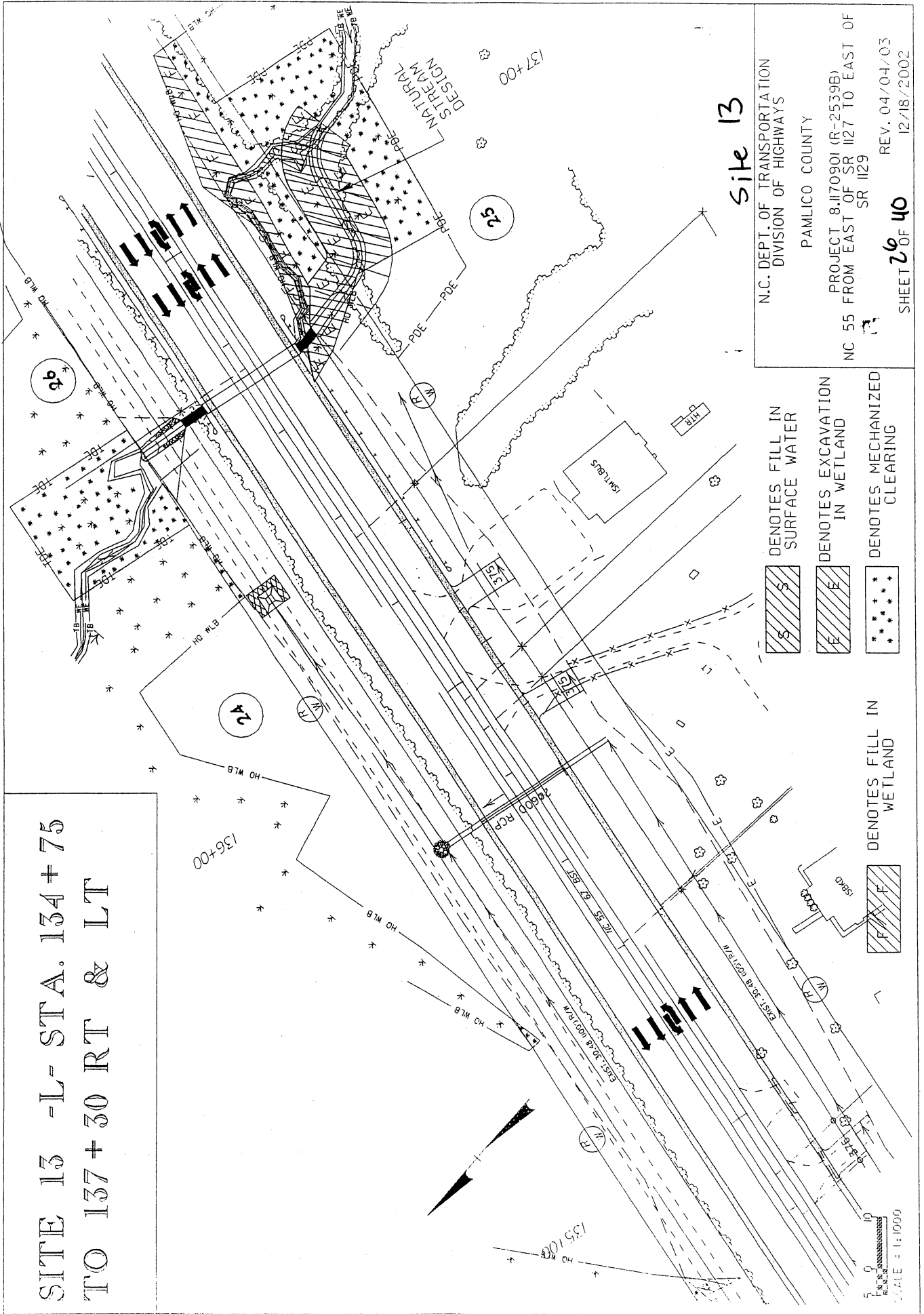



side 13

N.C. DEPT. OF TRANSPORTATION
DIVISION OF HIGHWAYS

PAMLICO COUNTY

PROJECT 8.1170901 (R-2539B)
NC 55 FROM EAST OF SR 1127 TO EAST OF SR 1129

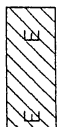
REV. 04/04/03
12/18/2002

 DENOTES FILL IN SURFACE WATER
 DENOTES EXCAVATION IN WETLAND
 DENOTES MECHANIZED CLEARING

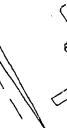
 DENOTES FILL IN WETLAND

SCALE = 1:1000

SHEET 26 OF 40

NCDOT Project I.D. R-2539B
Pamlico County, NC
NC 55 from East of SR 1127 to
East of SR 1129

Prepared by: MA Engineering Consultants, Inc.
598 East Chatham Street, Suite 137
Cary, North Carolina 27511

July 1, 2002

NATURAL CHANNEL DESIGN

WEST FORK GOOSE CREEK TRIBUTARY

Right of Project Station -L- 136+90

The construction of the proposed project will require that a portion of West Fork Goose Creek Tributary be relocated from Project Station -L- 136+73 RT. to Station 137+05 RT., some 41 m (135') in length. The proposed channel relocation is designed according to "natural channel" design principles proposed by Dave Rosgen.

The drainage area is in Pamlico County and is rural with woods in nature. It is not expected to be developed in the future. The stream was found to be intermittent in nature. Neuse River Buffer Rule will be applied for the stream.

There are no hydraulic gage data available neither on this stream nor on nearby streams. Current discharges were estimated using NCDOT procedures for rural watersheds.

Existing Channel

The natural skew angle for the stream crossing is about 50 degree. Most of the natural channel along this reach has been extensively channelized and straightened in the past as the result of the 90-degree box culvert crossing. Most of the floodplain vegetation on the north side has been removed to accommodate the existing roadway embankment. The current channel is parallel to the roadway and has a bottom of silt. The entire channel (from Station -L- 136+72 RT to Station 137+05 RT) was surveyed in detail for the purpose of channel classification, and was found to be an E6 type of stream according to the Rosgen classification scheme.

Sheet 7.7 of 46

Reference Reach

Because of the altered state of the existing channel, a "reference reach" of this stream was also surveyed in order to classify its unaltered natural condition. The selected reach is located some 42 m (138') upstream of the NC 55 crossing. A 66 m (217') long reach was surveyed in detail.

A downstream reach was not selected for the following reasons:

1. The distance from the existing box culvert to the confluence with West Fork Goose Creek is only 60m (197'). The backwater effect of the creek has significant impact on the reach.
2. There is an abandoned railroad embankment across the channel and entire floodplain. It has impact on the natural condition of the reach.

The upstream reach was selected because it is natural and has no impact of human activities for the entire floodplain. It has about the same drainage area as the existing channel site.

Analysis of reference reach's data lead to a stream classification of E6. This portion of channel has a silt bed. Water depth at riffle and pool were about 0.04 m (0.13') and 0.14 m (0.46'), respectively.

Proposed Channel

The proposed channel design has an E6 classification. Design data is given in the attached data table along with existing reach and reference reach data. Channel gradient is controlled by the proposed 1.8m x 1.2m (6' x 4') reinforced concrete box culvert extension downstream and by the natural channel tie-in upstream. Channel sinuosity closely matches that of the reference reach. Mean "bankfull" depth was set at 0.26 m (0.85') close to the measured depth of 0.25 m (0.82') for the reference reaches. This gives a maximum bankfull depth of 0.37 m (1.21'). Above bankfull depth, it is proposed to excavate a flood plain on both sides of meander bend, resulting in approximately an 11.4 m (37') wide flood plain (including the channel). The floodplain width for the reference reach is about 12 m (39').

It is believed that by forming a floodplain above bankfull depth channel stability will be enhanced by reducing velocities for those discharges above the bankfull discharge. This should lead to a more stable channel during the stream form and fluvial processes. It is anticipated that the proposed channel will have a silt bottom. Pool depths of 0.1 m (0.3') are proposed at outside bends of meanders. This is the average depth of pools in the reference reach.

Proposed channel stabilization is shown on the attached detail sheet. It is anticipated that channel banks will be planted with native trees and shrubs above bankfull depth.

Handwritten note: -Mont 78 at 40

The existing drainage area is rural with woods in nature. The only land-disturbing activities may be the agricultural practices near the boundary of the watershed. Very thick and tall vegetation/brush were found along both sides of the stream in the wooded area. They were functioning as natural sediment control filters. During field study, the water in the stream was clean and clear. No visible suspended sediment or clogging of the stream was found. This indicated that reduction of in-stream photosynthesis due to suspended sediment was not likely. The W/D ratio of the reference stream indicated that shear stress was not concentrated near the bank region and the bank erosion was not accelerated. Observed vegetation in the channel and lichens on the streambed also indicated that the bank was stable. The increase in sediment supply to the channel developing from bank erosion and gradually losing its capability to transport sediment was not likely for the stream.

Proposed land use is rural in natural and no development is expected in the future. Impervious area and land-disturbing activities due to farming will not be increased. Thus, the discharge and the sediment input will not be increased. Neuse River Buffer Rule will be applied and all storm drain outlets will be outside the buffer for filtration. Therefore, the potential sediment transport to the stream will be minimized in the future.

The existing stream bed material for the reference reach is silt with uniform size throughout the whole reach. No gravel or pebble was found. Therefore, a pebble count was not feasible. The proposed channel relocation is only 41m (135') with 0.34% slope.

oh to b2 from S

Appendix B

Morphological Measurement Table

Variables	Existing Channel	Proposed Reach	USGS Station	Reference Reach
1. Stream type	Intermittent	Intermittent		Intermittent
2. Drainage area	109 Ac	109 Ac		109 Ac
3. Bankfull width	3.6'	7.8'		7.9'
4. Bankfull mean depth	1.3'	0.9'		0.8'
5. Width/depth ratio	2.80	9.20		9.50
6. Bankfull cross-sectional area	4.6 ft ²	6.6 ft ²		6.6 ft ²
7. Bankfull mean velocity	4.1 ft/s	2.1 ft/s		3.3 ft/s
8. Bankfull discharge, cfs	24.7 cfs	24.7 cfs		24.7 cfs
9. Bankfull max depth	1.7'	1.2'		1.2'
10. Width of flood prone area	69'	37'		39'
11. Entrenchment ratio	19.0	4.8		5.0
12. Meander length	131'	131'		131'
13. Ratio of meander length to bankfull width	36.4	16.8		16.7
14. Radius of curvature	26'	26'		26'
15. Ratio of radius of curvature to bankfull width	7.3	3.4		3.3
16. Belt width	36'	41'		41'
17. Meander width ratio	9.1	4.2		4.2
18. Sinuosity (stream length/valley length)	1.09	1.14		1.15
19. Valley Slope	1.42 %	0.39 %		1.13 %
20. Average slope	1.30 %	0.34 %		0.98 %
21. Pool slope	1.30 %	0.30 %		0.98 %
22. Ratio of pool slope to average slope	1.0	1.0		1.0
23. Maximum pool depth	0.5'	0.6'		0.3'
24. Ratio of pool depth to average bankfull depth	0.41	0.69		0.40
25. Pool width	1.6'	3.0'		4.4'
26. Ratio of pool width to bankfull width	0.45	0.38		0.56
27. Pool to pool spacing	26'	66'		27'
28. Ratio of pool to pool spacing to bankfull width	7.3	8.4		3.4
29. Ratio of lowest bank height to bankfull height (or max bankfull depth)	0.61	0.79		0.44

NC DEPT. OF TRANSPORTATION

PAMLICO COUNTY

PROJECT: R-2539B

WEST FORK GOOSE CREEK TRIBUTARY

-L- 136+90 RT

SHEET 4 OF 5 6-18-02

Sheet 30 of 40

NATURAL CHANNEL DESIGN TYPICALS

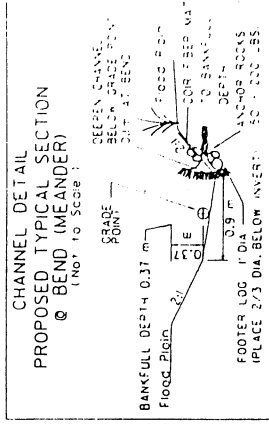
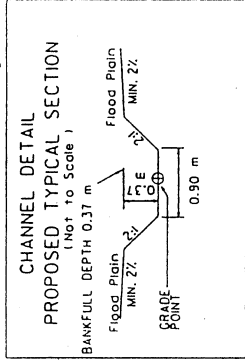
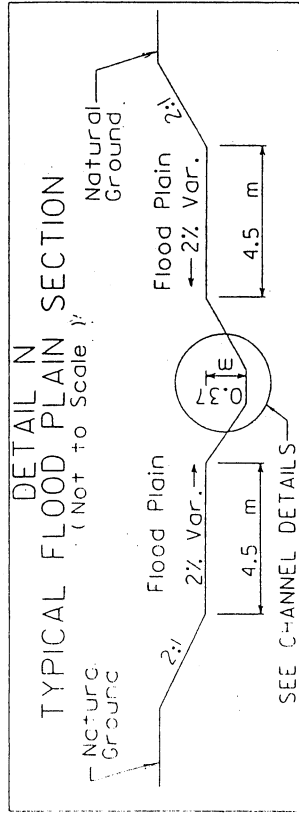

TYPICAL SECTION I BETWEEN BENDS

TYPICAL SECTION 2 AT BENDS

NOTES:

- NUMBER OF ROOTWADS INSTALLED TO BE DETERMINED IN SITE
- ROOTWADS TO BE SPACED 4x DIAMETER OF ROOT BASE
- FOOTER LOG ANCHOR ROCK TO BE PLACED ON THE DOWNSTREAM END OF EACH FOOTER LOG SO THAT IT IS LEANING AGAINST THE LOG ON THE SIDE AWAY FROM THE CHANNEL.
- WHEN BACKFILLING OVER AND AROUND FOOTER LOGS, ROOTWAD LOGS AND ANCHOR ROCKS FIRMLY SECURE ALL COMPONENTS INCLUDING JOINTS, CONNECTIONS AND GAPS.
- PLANTINGS SHOULD BE PLACED ABOVE BANKFULL DEPTH.

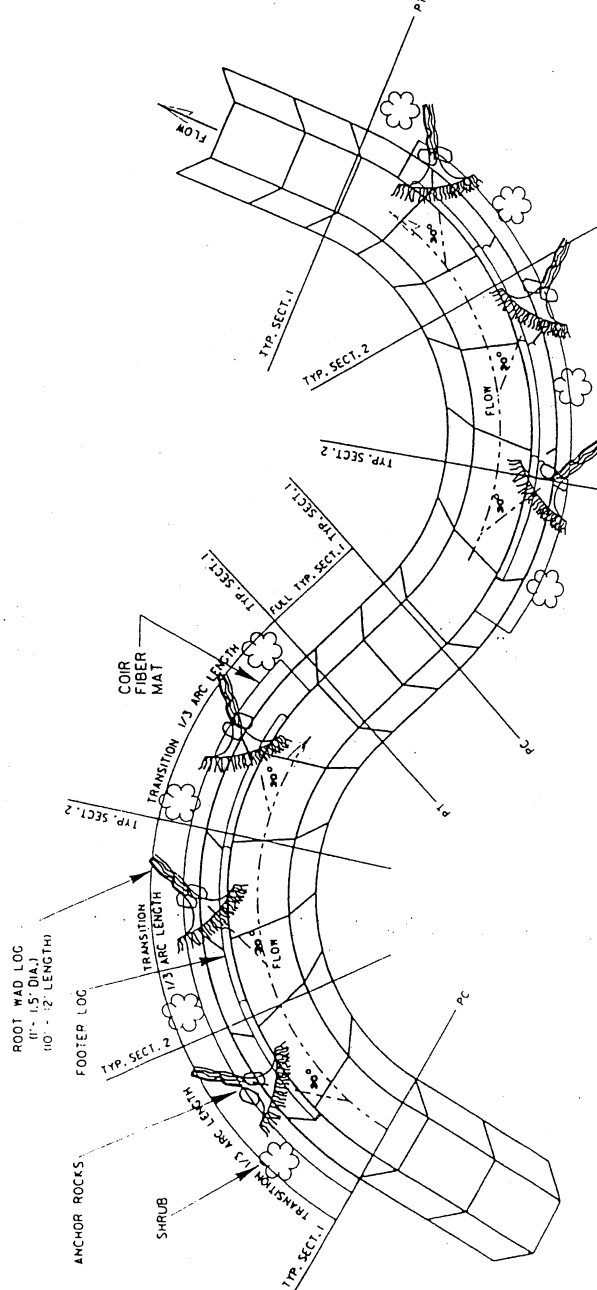

CHANNEL PLAN VIEW WEST FORK GOOSE CREEK TRIBUTARY

N. C. DEPT. OF TRANSPORTATION
DIVISION OF HIGHWAYS

PAMLICO COUNTY
PROJECT: R-2539B

-L- STATION 136 + 90 RT

31 40
SHEET 8 OF 8

5-31-01

CROSS VANE ROCK WEIR DETAIL

PLAN VIEW

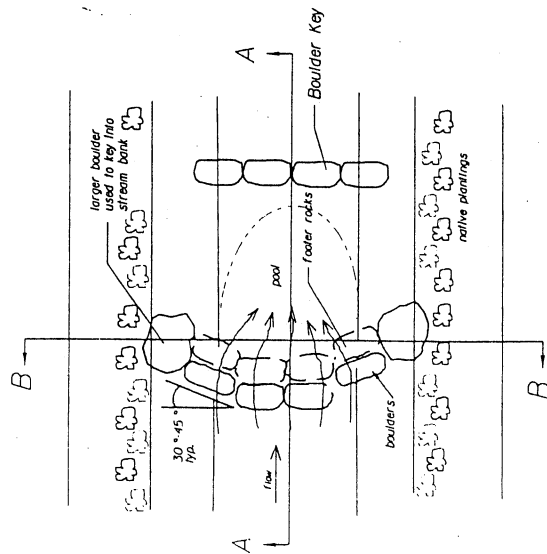

SECTION B-B

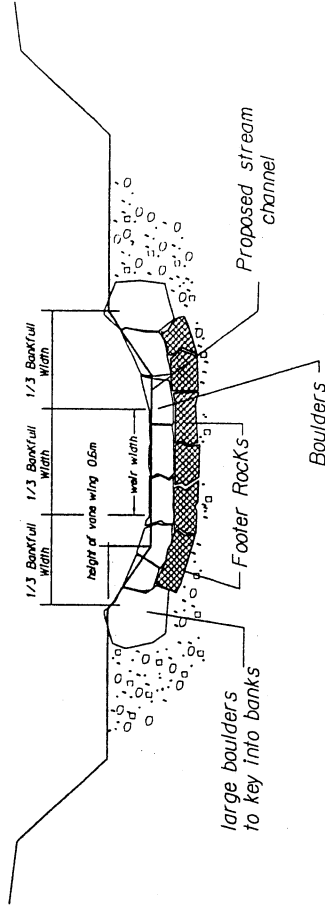

NOTE:

Footer Rocks/Boulders should be native quarried rock or locally shot rock, angular and oblong preferably with flat sides with approximate dimensions of 0.9m x 0.6m x 0.6m

Larger boulders should have approximate dimensions of 1.2m x 0.9m x 0.9m

Rocks should fit tightly with no spaces between PSRM (Permanent Soil Reinforcement Mat)

SECTION A-A

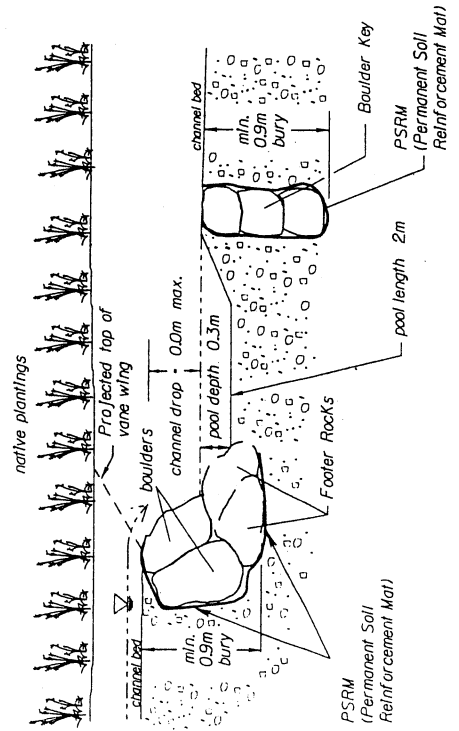

N. C. DEPT. OF TRANSPORTATION
DIVISION OF HIGHWAYS

PAMLICO COUNTY
PROJECT: R-2559B
WEST FORK GOOSE
CREEK TRIBUTARY
-L- 136 + 90 RT

STREAM RELOCATION

-L- STA 136 + 73 RT TO 137 + 05 RT

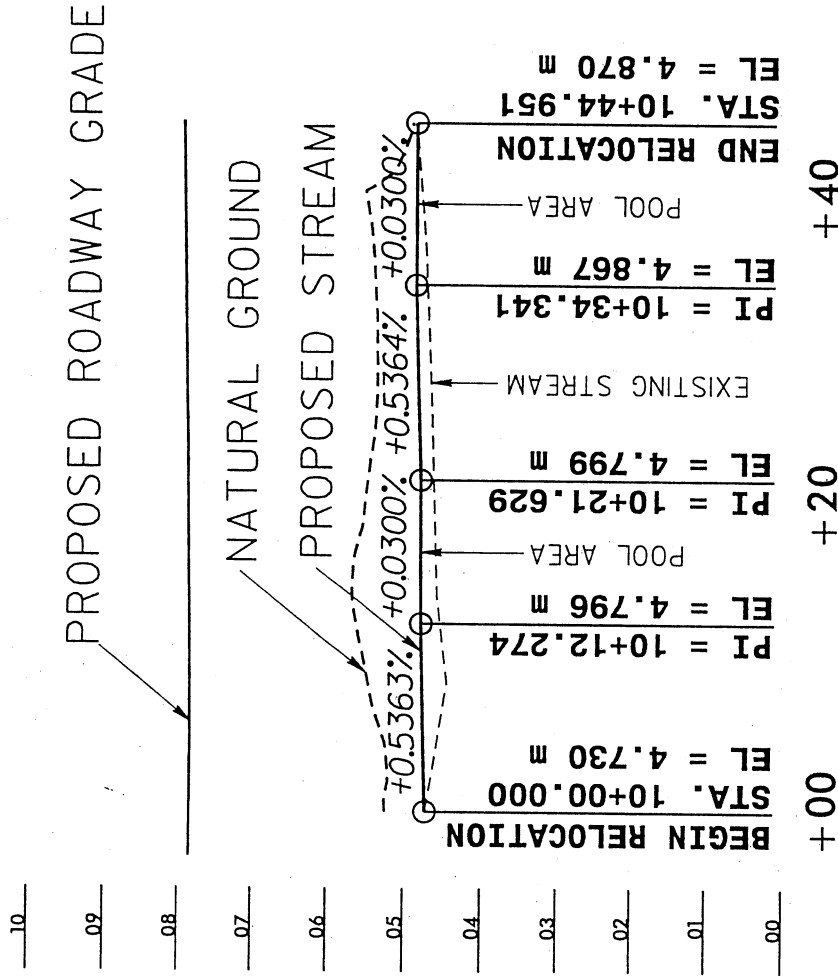

STREAM LENGTH

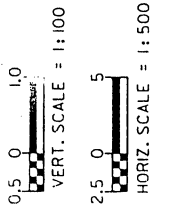

N. C. DEPT. OF TRANSPORTATION
 DIVISION OF HIGHWAYS

PAMLICO COUNTY
 PROJECT: R-2539B
 WEST FORK GOOSE
 CREEK TRIBUTARY
 -L- 136 + 90 RT

STREAM RELOCATION

-L- STA 136+73 RT TO 137+05 RT

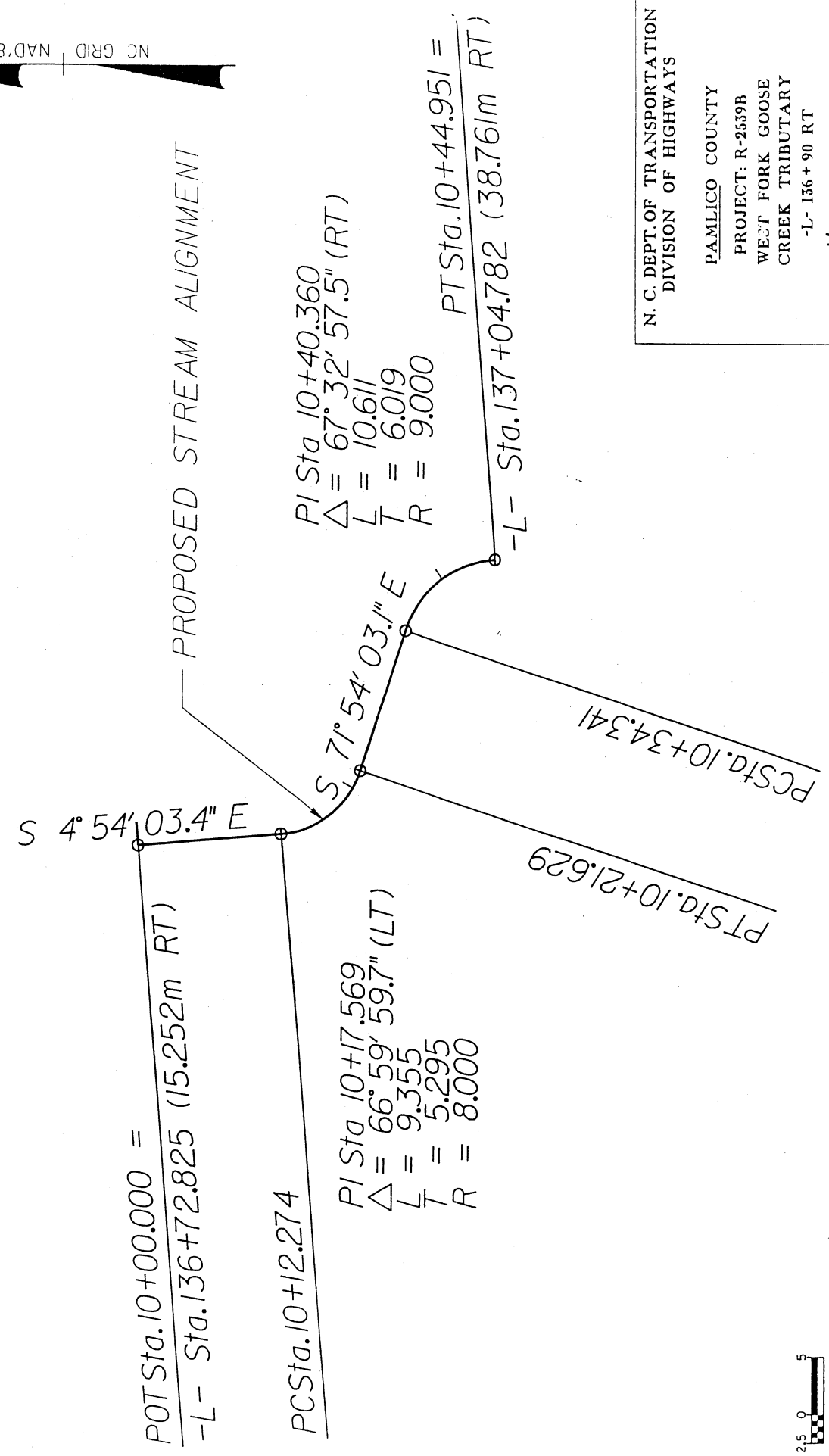
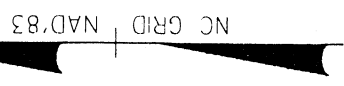

POT Sta. 10+00.000 =
 -L- Sta. 136+72.825 (15.252m RT)

PC Sta. 10+12.274
 PI Sta. 10+17.569
 $\Delta = 66^\circ 59' 59.7''$ (LT)
 $L = 9.355$
 $T = 5.295$
 $R = 8.000$

PI Sta. 10+40.360
 $\Delta = 67^\circ 32' 57.5''$ (RT)
 $L = 10.611$
 $T = 6.019$
 $R = 9.000$

PT Sta. 10+44.951 =
 -L- Sta. 137+04.782 (38.761m RT)

PT Sta. 10+21.629

PC Sta. 10+34.341

PROPOSED STREAM ALIGNMENT



N. C. DEPT. OF TRANSPORTATION
 DIVISION OF HIGHWAYS



PAMLICO COUNTY
 PROJECT: R-2539B
 WEST FORK GOOSE
 CREEK TRIBUTARY
 -L- 136+90 RT

SHEET 34 OF 40
 4-4-03

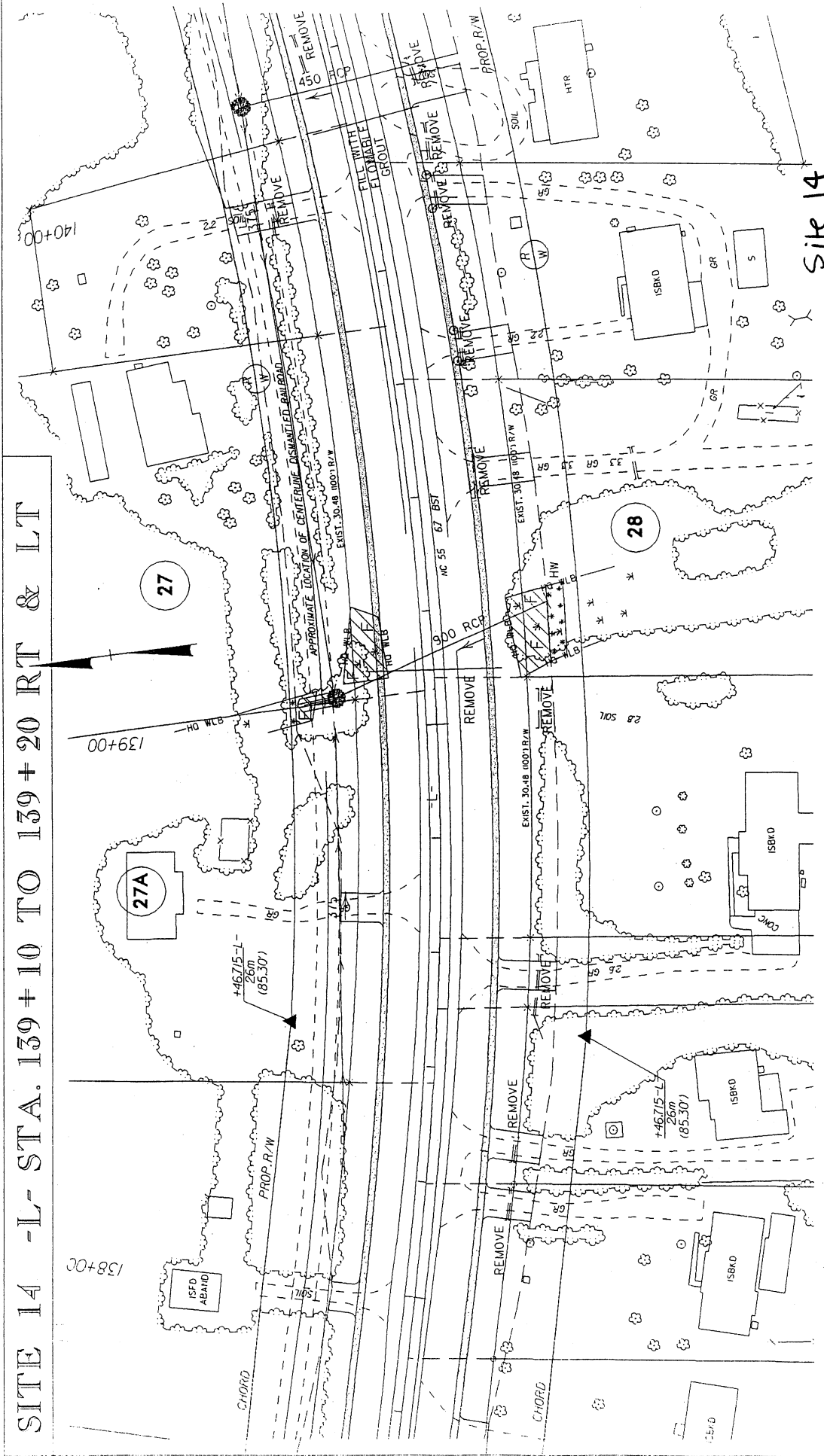
SITE 14 -L- STA. 139+10 TO 139+20 RT & LT

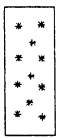

N.C. DEPT. OF TRANSPORTATION
 DIVISION OF HIGHWAYS
 PAMLICO COUNTY
 PROJECT 8.II70901 (R-2539B)
 NC_55 FROM EAST OF SR I127 TO EAST OF
 SR I129
 REV. 04/04/03
 12/18/2002

-  DENOTES FILL IN WETLAND
-  DENOTES EXCAVATION IN WETLAND
-  DENOTES MECHANIZED CLEARING

Site 14

SHEET 35 OF 40

SCALE = 1:1000

SITE 15 -L- STA. 145+35 TO 146+75 LT

147+00

29

146+00

145+00

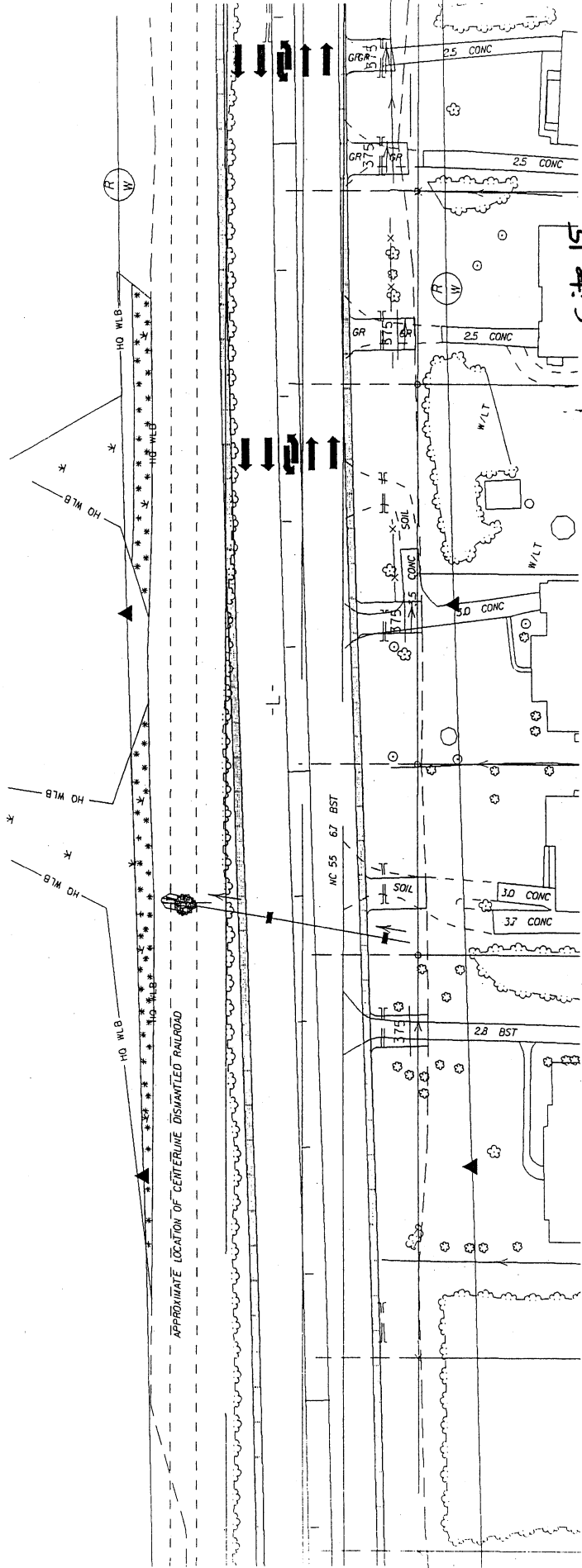

DENOTES MECHANIZED
CLEARING

N.C. DEPT. OF TRANSPORTATION
DIVISION OF HIGHWAYS
PAMLICO COUNTY
PROJECT 8-1170901 (R-2539B)
NC 55 FROM EAST OF SR 1127 TO EAST OF
SR 1129
REV. 04/04/03
12/18/2002

39
SHEET OF 40

Site 15

SITE 16 -L- STA. 148+10 TO 150+00 RT & LT

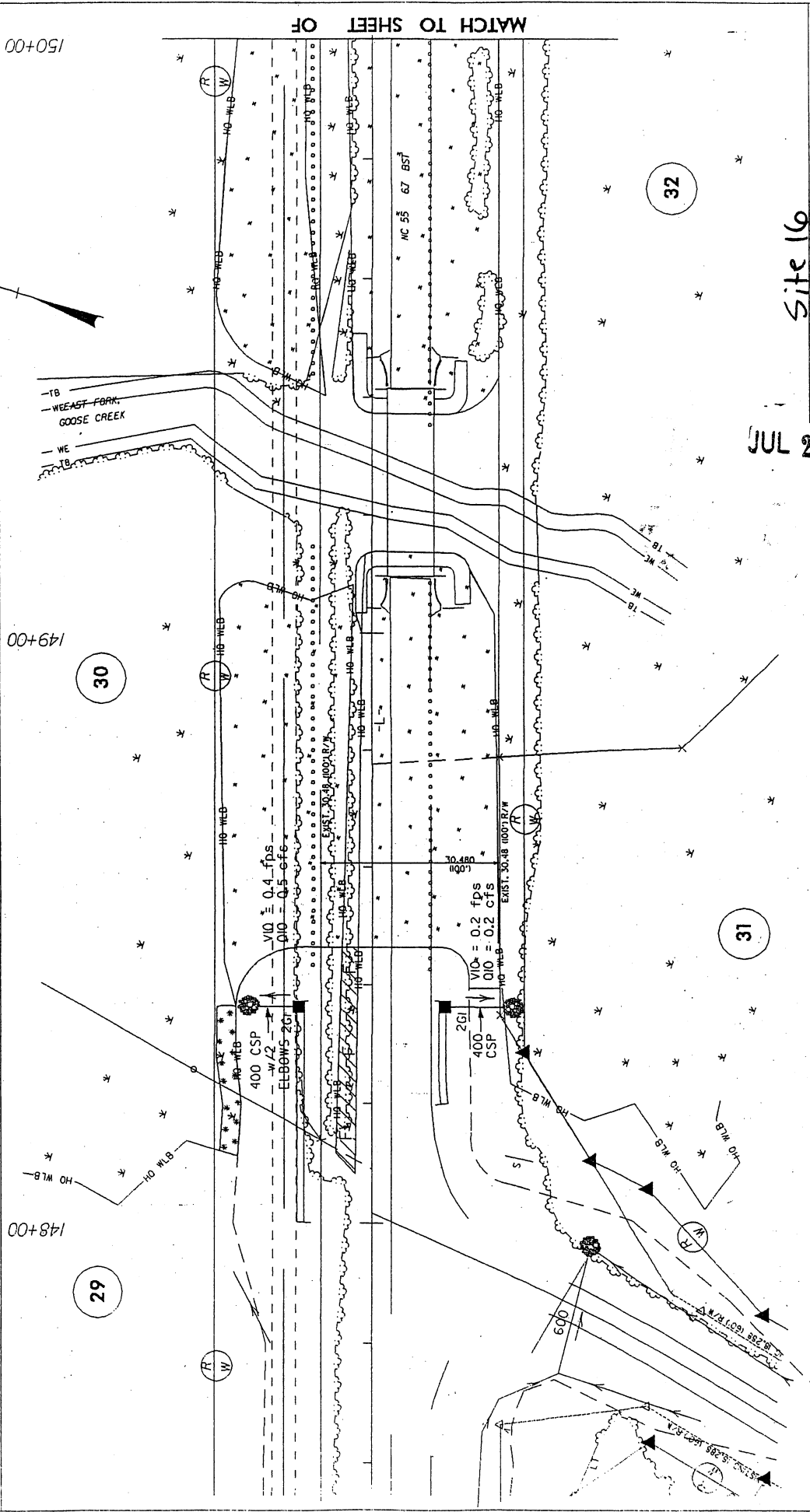

- DENOTES WETLAND RESTORATION
- DENOTES FILL IN WETLAND
- DENOTES MECHANIZED CLEARING

Site 16

JUL 24 2003

N.C. DEPT. OF TRANSPORTATION
 DIVISION OF HIGHWAYS
 PAMLICO COUNTY
 PROJECT 8.1170901 (R-2539B)
 FROM EAST OF SR 1127 TO EAST OF
 SR 1129
 REV. 04/04/03

SCALE = 1:1000

37 un

149+00

148+00

150+00

30

29

32

31

MATCH TO SHEET OF

RECEIVED

OCT 08 2003

**J.N. OF CONSTRUCTION MANAGEMENT
FARMER**

PI - 150+80.00
EL - 7.120m
VC - 30m
G1 - (+0.300%)
G2 - (+0.210%)

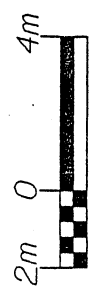
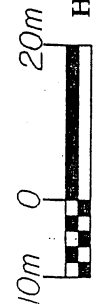
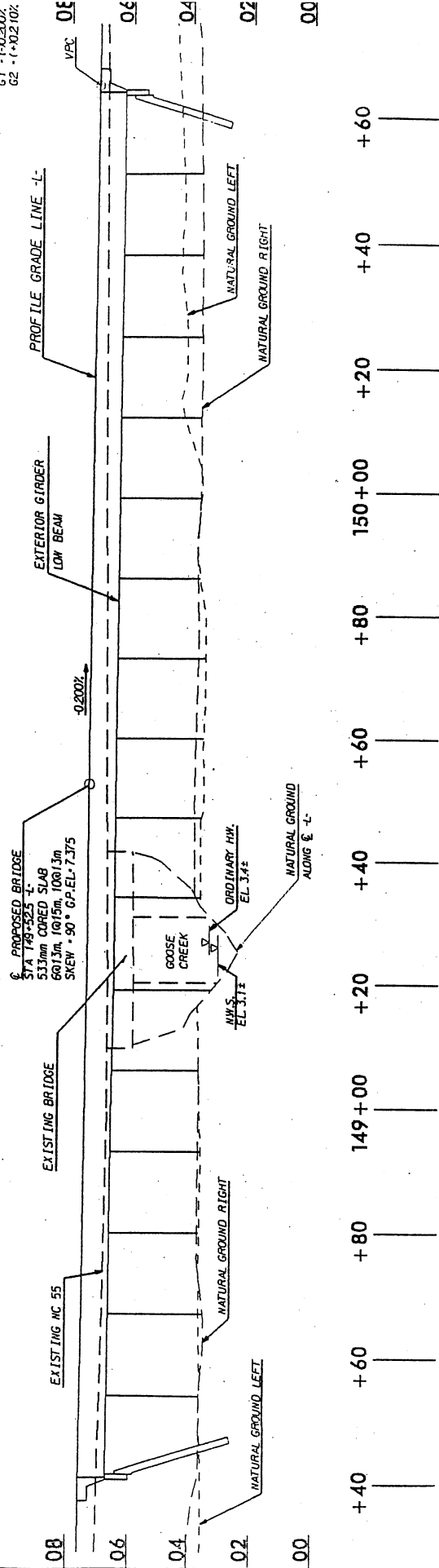

BRIDGE PROFILE SITE 16

NC. DEPT. OF TRANSPORTATION
DIVISION OF HIGHWAYS

PAMLICO COUNTY

PROJECT: 8.1170901 (R-2539B)

NC 55 FROM EAST OF SR 1127 TO
EAST OF SR 1129

SHEET 37-A OF 40

12 / 18 / 02

SITE 16 -L- STA. 150+00 TO 151+40 RT & LT

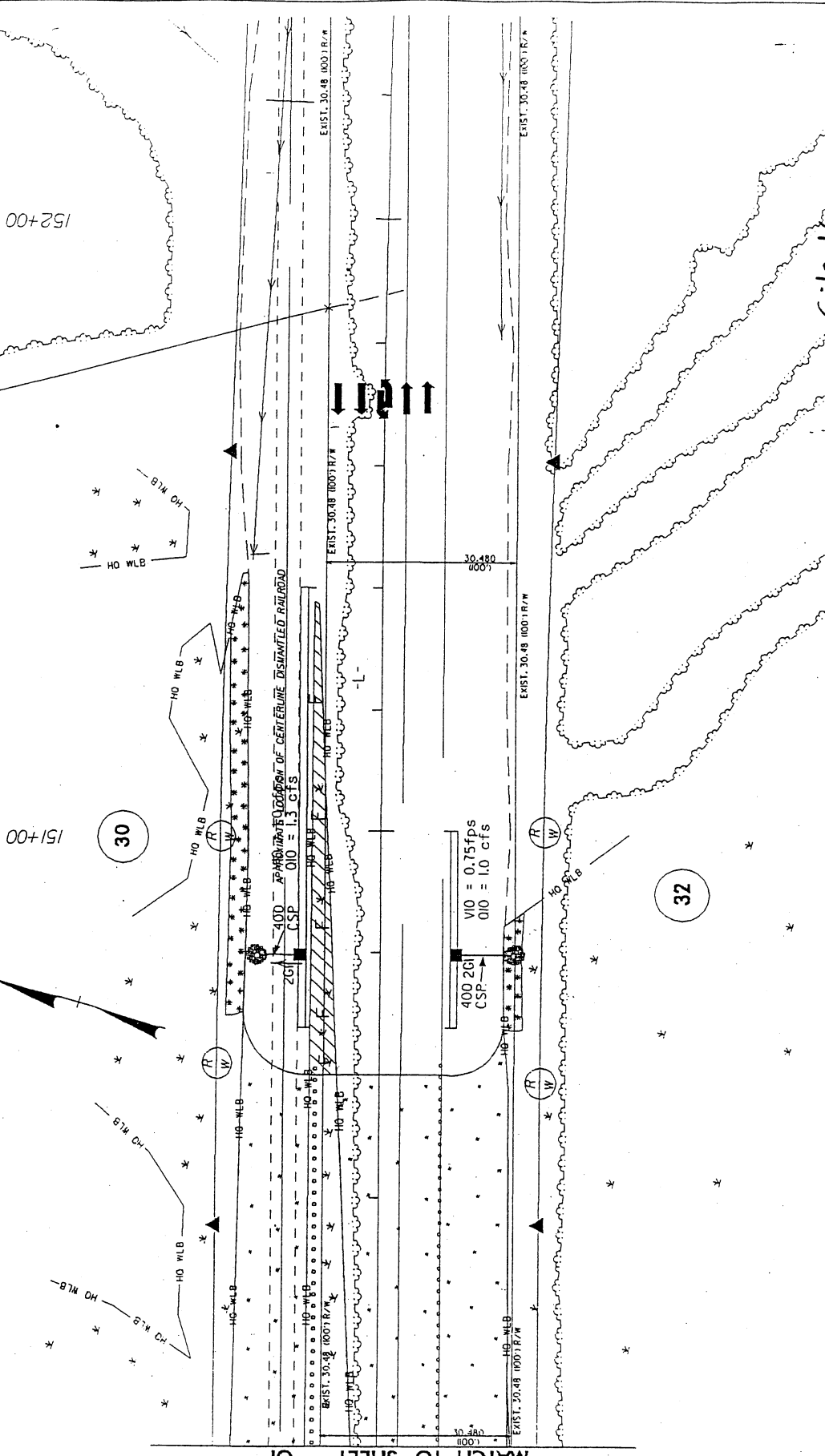

- DENOTES WETLAND RESTORATION
- DENOTES FILL IN WETLAND
- DENOTES MECHANIZED CLEARING

N.C. DEPT. OF TRANSPORTATION
 DIVISION OF HIGHWAYS
 PAMLICO COUNTY
 PROJECT 8-1170901 (R-2539B)
 NC 55 FROM EAST OF SR 1127 TO EAST OF SR 1129
 17 28 110 REV. 04/04/05

Site 16

SCALE = 1:10000

RECEIVED

OCT 29 2003

**DIV. OF COASTAL MANAGEMENT
RALEIGH**

WETLAND PERMIT IMPACT SUMMARY

Site No.	Station (From/To)	Structure Size / Type	WETLAND IMPACTS				SURFACE WATER IMPACTS							
			Fill In Wetlands (ha)	Temp. Fill In Wetlands (ha)	Excavation In Wetlands (ha)	Mechanized Clearing (Methiod III) (ha)	Fill In SW (Natural) (ha)	Fill In SW (Pond) (ha)	Temp. Fill In SW (ha)	Existing Channel Impacted (m)	Natural Stream Design (m)			
1	56+30 TO 56+55				0.034	0.008								
2	59+70 TO 61+00	EXTENSION OF 2 @ 1650 RCP w/COLLARS	0.051		0.012	0.019	0.004					22		
3	62+25 TO 63+60		0.055			0.010								
*4	74+85 TO 77+40	BRIDGE: 5 SPAN (5 @ 20m) = 100m 1143mm PRESTRESSED CONCRETE GIRDERS	0.136	0.003	0.004	0.057								
5	81+85 TO 82+00	EXTENSION OF 1050 RCP w/COLLARS	0.012			0.005	0.001						16	
6	102+35 TO 103+65		0.047			0.038								
7	108+50 TO 114+00	EXTENSION OF 1.8 x 1.2 & 1.2 x 1.2 RCBC (TWO CELLS)	0.286			0.208	0.003						16	
8	117+20 TO 118+60		0.008			0.038								
9	119+20 TO 120+20		0.020			0.023								
10	121+70 TO 122+20		0.045			0.013								
11	123+75 TO 125+60		0.021			0.017								
13	134+75 TO 137+30	EXTENSION OF 1.8 x 1.2 RCBC	0.027		0.048	0.132	0.006					36		41
14	139+10 TO 139+20		0.017		0.002	0.004								
15	145+35 TO 146+75		0.000			0.035								
**16	148+10 TO 151+40	BRIDGE: 17 SPAN (6 @ 13m, 1 @ 15m, 10 @ 13m) = 223m 533mm CORED SLAB	0.030			0.034								
TOTALS:			0.754	0.003	0.100	0.841	0.014	0.000	0.000	0.000	0.000	90	41	

* SITE NO. 4 - EXISTING ROAD REMOVED, RECLAIMED WETLAND = 0.234 (ha)

** SITE NO. 16 - EXISTING ROAD AND RAILROAD EMBANKMENT REMOVED; RECLAIMED WETLAND = 0.754 (ha)

N.C. DEPT. OF TRANSPORTATION
DIVISION OF HIGHWAYS

PAMLICO COUNTY

PROJECT 8.1170901 (R-2539B)
NC 55 FROM EAST OF SR 1127 TO EAST OF SR 1129

39 Revised
SHEET OF 40 10/21/03

WETLAND PERMIT IMPACT SUMMARY

Site No.	Station (From/To)	Structure Size / Type	WETLAND IMPACTS					SURFACE WATER IMPACTS						
			Fill In Wetlands (ac)	Temp. Fill In Wetlands (ac)	Excavation In Wetlands (ac)	Mechanized Clearing (Method III) (ac)	Fill In SW (Natural) (ac)	Fill In SW (Pond) (ac)	Temp. Fill In SW (ac)	Existing Channel Impacted (ft)	Natural Stream Design (ft)			
*1	56+30 TO 56+55				0.08	0.02								
2	59+70 TO 61+00	EXTENSION OF 2@ 1650 RCP w/ COLLARS	0.13		0.03	0.05	0.01						72.2	
3	62+25 TO 63+60		0.14			0.02								
**4	74+85 TO 77+40	EXTENSION OF 1.8 x 1.2 & 1.2 x 1.2 RCBC (TWO CELLS)	0.34	0.01	0.01	0.14								
5	81+85 TO 82+00	EXTENSION OF 1050 BRCP w/ COLLARS	0.03			0.01	0.00						52.5	
6	102+35 TO 103+65		0.12			0.09								
7	108+50 TO 114+00	EXTENSION OF 1.8 x 1.2 & 1.2 x 1.2 RCBC (TWO CELLS)	0.71			0.44	0.01						52.5	
8	117+20 TO 118+60		0.02			0.09								
9	119+20 TO 120+20		0.05			0.06								
10	121+70 TO 122+20		0.11			0.03								
11	123+75 TO 125+60		0.05			0.04								
13	134+75 TO 137+30	EXTENSION OF 1.8 x 1.2 RCBC	0.07		0.12	0.33	0.01						118.1	134.5
14	139+10 TO 139+20		0.04		0.00	0.01								
15	145+35 TO 146+75					0.09								
***16	148+10 TO 151+40	15m, 10 @ 13m) = 223m 533mm CORED SLAB	0.07			0.08								
TOTALS			1.87	0.01	0.25	1.51	0.03	0.00	0.00	0.00	0.00	295.20	134.48	

* SITE NO. 1 - DRAINAGE IMPACTS TOTAL 0.06 ACRES OF NON-RIVERINE WETLAND

** SITE NO. 4 - EXISTING ROAD REMOVED, RECLAIMED WETLAND = 0.58 (ac)

*** SITE NO. 16 - EXISTING ROAD AND RAILROAD EMBANKMENT REMOVED, RECLAIMED WETLAND = 1.87 (ac)

NC DEPARTMENT OF TRANSPORTATION
DIVISION OF HIGHWAYS

PROJECT 8.1170901 (R-2539B)
NC 55 FROM EAST OF SR 1127 TO EAST OF SR 1129

Buffer

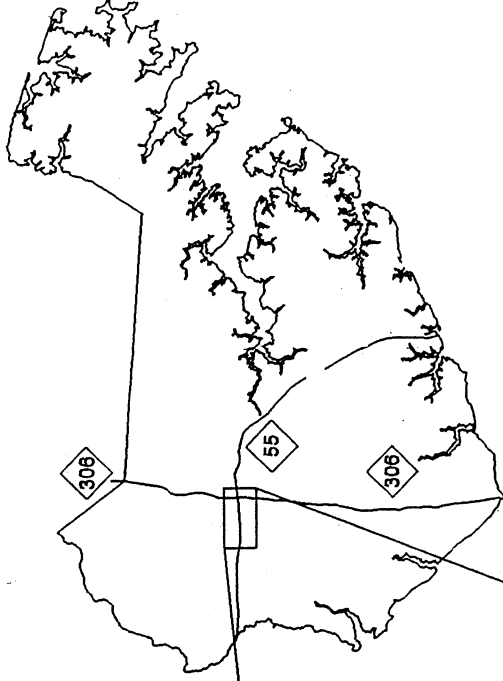
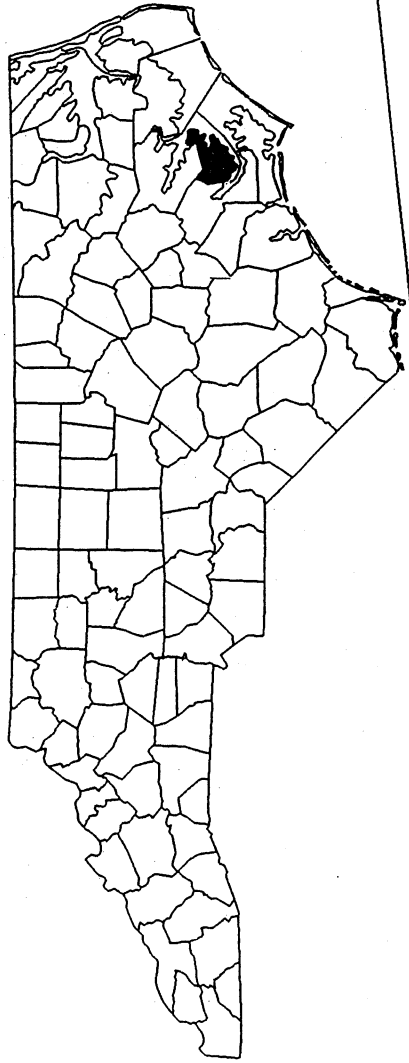

PAMLICO COUNTY

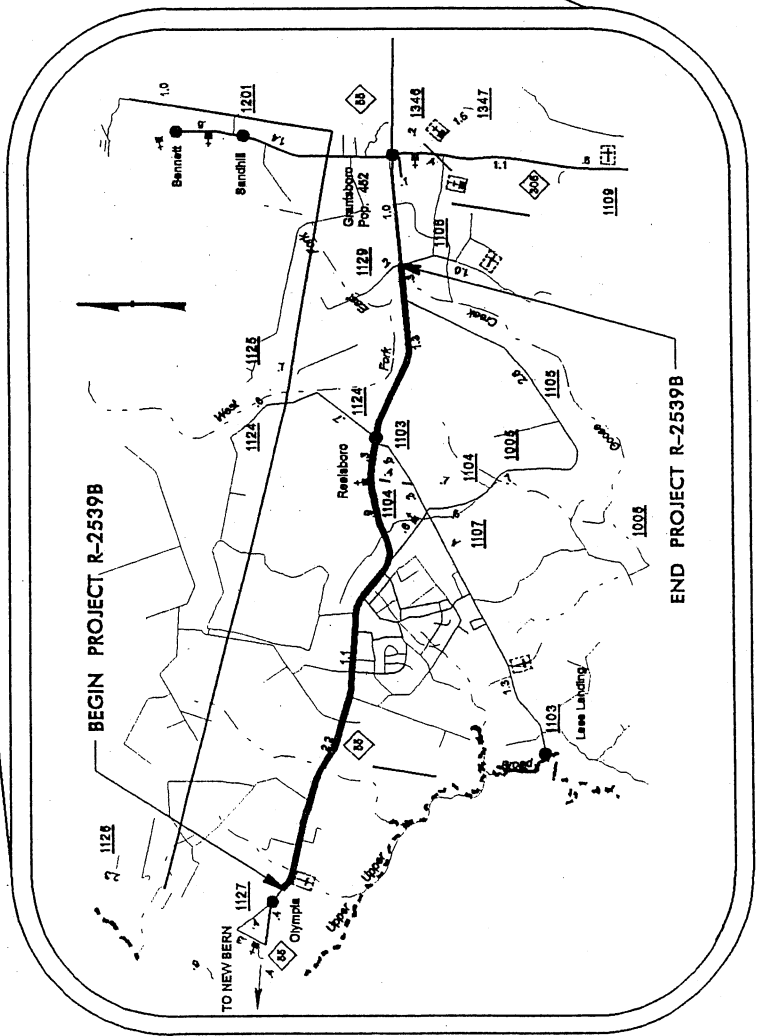

N.C. DEPT. OF TRANSPORTATION
 DIVISION OF HIGHWAYS
 PAMLICO COUNTY
 PROJECT 8.I170901 (R-2539B)

NC 55 FROM EAST OF SR 1127 TO EAST OF SR 1129
 SHEET 61 of 12 12/18/2002

N.C. DEPT. OF TRANSPORTATION
DIVISION OF HIGHWAYS
PAMLICO COUNTY

NC 55 FROM EAST OF SR 1127 TO EAST
SR 1129

SHEET 82 OF 12

05/22/20

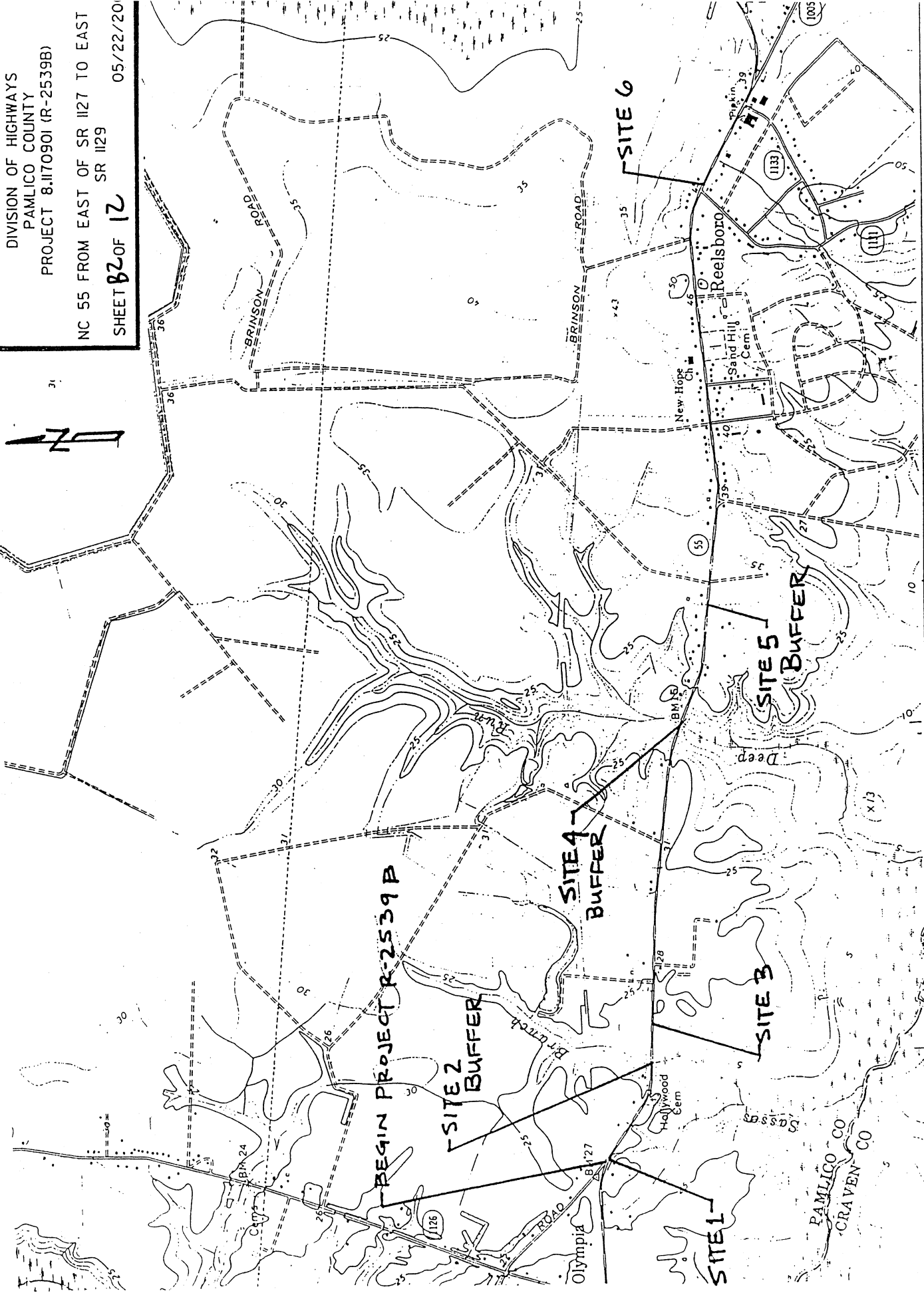

N.C. DEPT. OF TRANSPORTATION
DIVISION OF HIGHWAYS
PAMLICO COUNTY
PROJECT 8.I170901 (R-2539B)

NC 55 FROM EAST OF SR 1127 TO EAST OF
SR 1129
SHEET 03 OF 12

05/22/2002

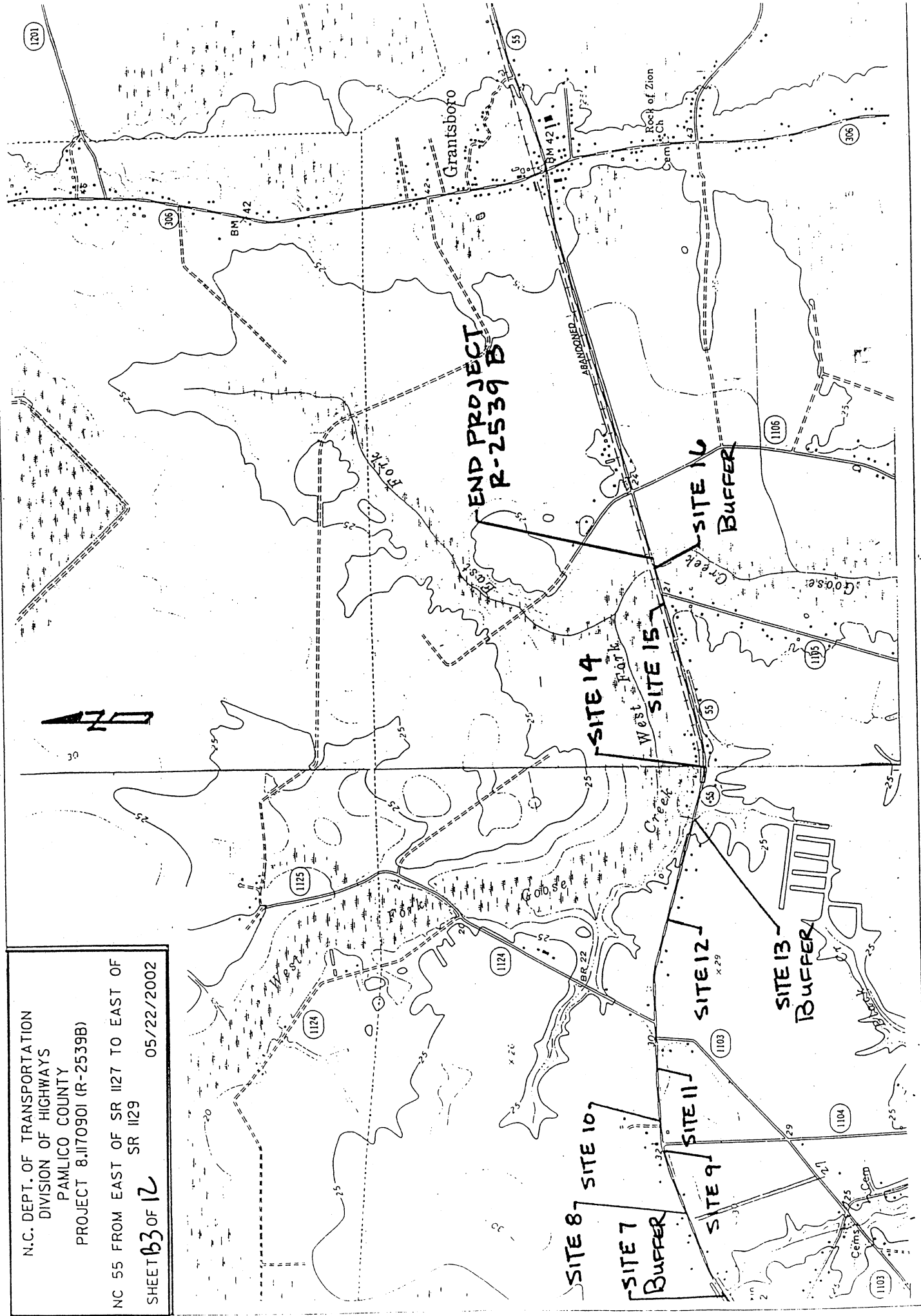

BUFFER LEGEND

—WLB— WETLAND BOUNDARY

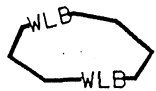
 WETLAND

 ALLOWABLE IMPACTS ZONE 1

 ALLOWABLE IMPACTS ZONE 2

 MITIGABLE IMPACTS ZONE 1

 MITIGABLE IMPACTS ZONE 2

—BZ— RIPARIAN BUFFER ZONE

—BZ1— RIPARIAN BUFFER ZONE 1
30 ft (9.2m)

—BZ2— RIPARIAN BUFFER ZONE 2
20 ft (6.1m)

→ → FLOW DIRECTION

—TB— TOP OF BANK

—WE— EDGE OF WATER

—C— PROP. LIMIT OF CUT

—F— PROP. LIMIT OF FILL

▲ PROP. RIGHT OF WAY

—NG— NATURAL GROUND

—PL— PROPERTY LINE

—TDE— TEMP. DRAINAGE EASEMENT

—PDE— PERMANENT DRAINAGE EASEMENT

—EAB— EXIST. ENDANGERED ANIMAL BOUNDARY

—EPB— EXIST. ENDANGERED PLANT BOUNDARY

—▽— WATER SURFACE

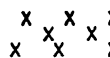
 LIVE STAKES

 BOULDER

— — — CORE FIBER ROLLS

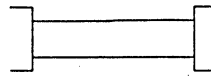
 PROPOSED BRIDGE

 PROPOSED BOX CULVERT

 PROPOSED PIPE CULVERT
12"-48"
PIPES
54" PIPES
& ABOVE

(DASHED LINES DENOTE EXISTING STRUCTURES)

 SINGLE TREE

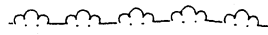
 WOODS LINE

 DRAINAGE INLET

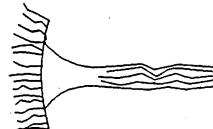
 ROOTWAD

 RIP RAP

 ADJACENT PROPERTY OWNER OR PARCEL NUMBER IF AVAILABLE

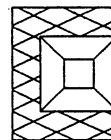
 PREFORMED SCOUR HOLE

 LEVEL SPREADER (LS)

 GRASS SWALE

N. C. DEPT. OF TRANSPORTATION
DIVISION OF HIGHWAYS
PAMLICO COUNTY

PROJECT: 8.1170901 (R-2339B)
NC 55 FROM EAST OF SR 1127
TO EAST OF SR 1129

SHEET **B4** OF 12 12 // 18 // 2002

SITE 2 -L- STA. 59+70 TO 61+00 LT

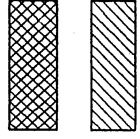
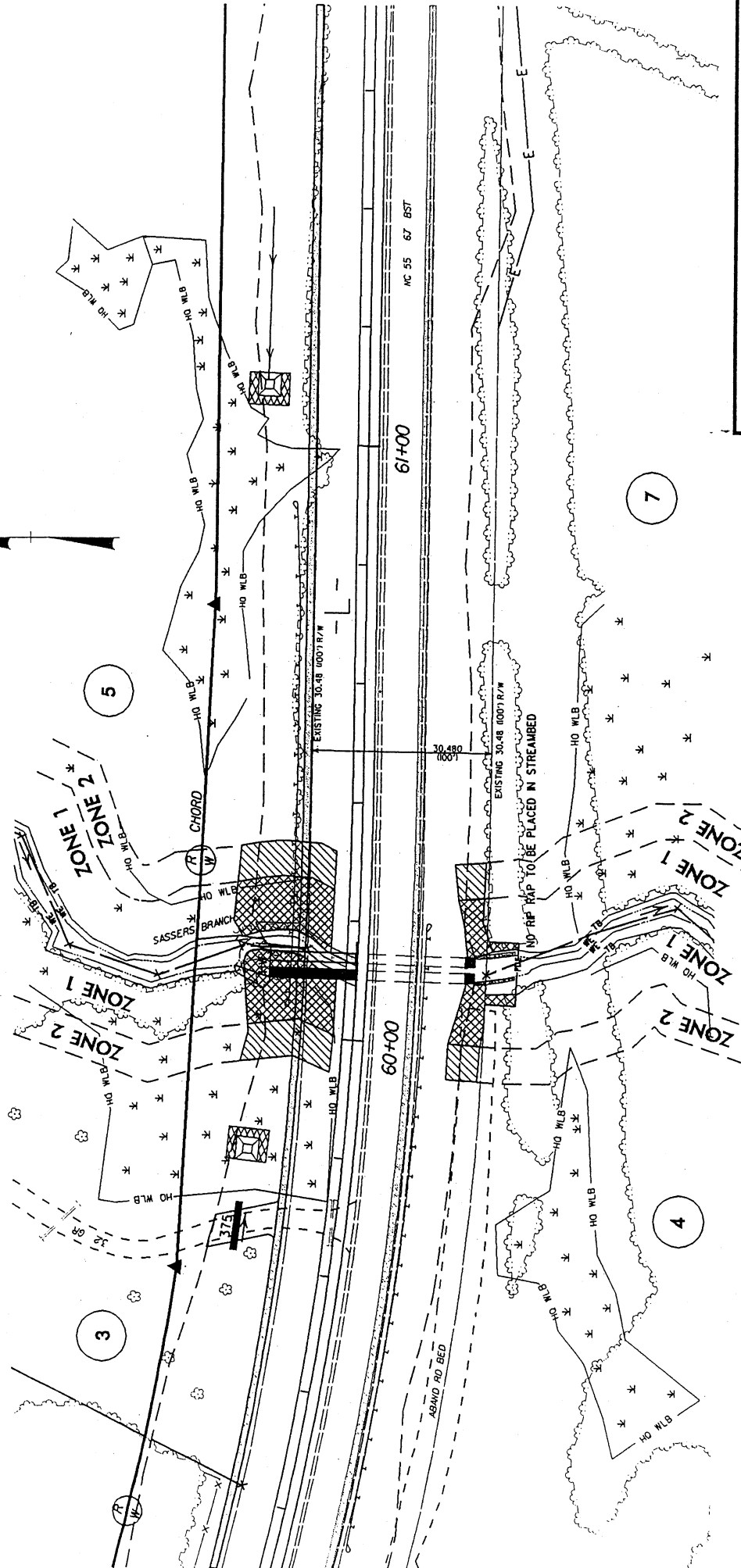
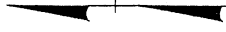

IMPACT ZONE 1

IMPACT ZONE 2

N.C. DEPT. OF TRANSPORTATION
 DIVISION OF HIGHWAYS
 PAMLICO COUNTY
 PROJECT 8.II7090I (R-2539B)
 NC 55 FROM EAST OF SR II27 TO EAST OF SR II29
 SR II29
B5
 SHEET OF 12
 06/24/2003

SCALE = 1:1000

SITE 4 -L- STA. 74+85 TO 77+40 RT & LT

GRASS SWALE
 DA = 1.8 AC
 V₂ = 2 fps
 Q₂ = 4.9 cfs
 V₁₀ = 2.4 fps
 Q₁₀ = 7.8 cfs
 SLOPE = 0.3% TO 1.5;
 SIDE SLOPE = 3:1
 BASE WIDTH = 5'
 LENGTH = 262'

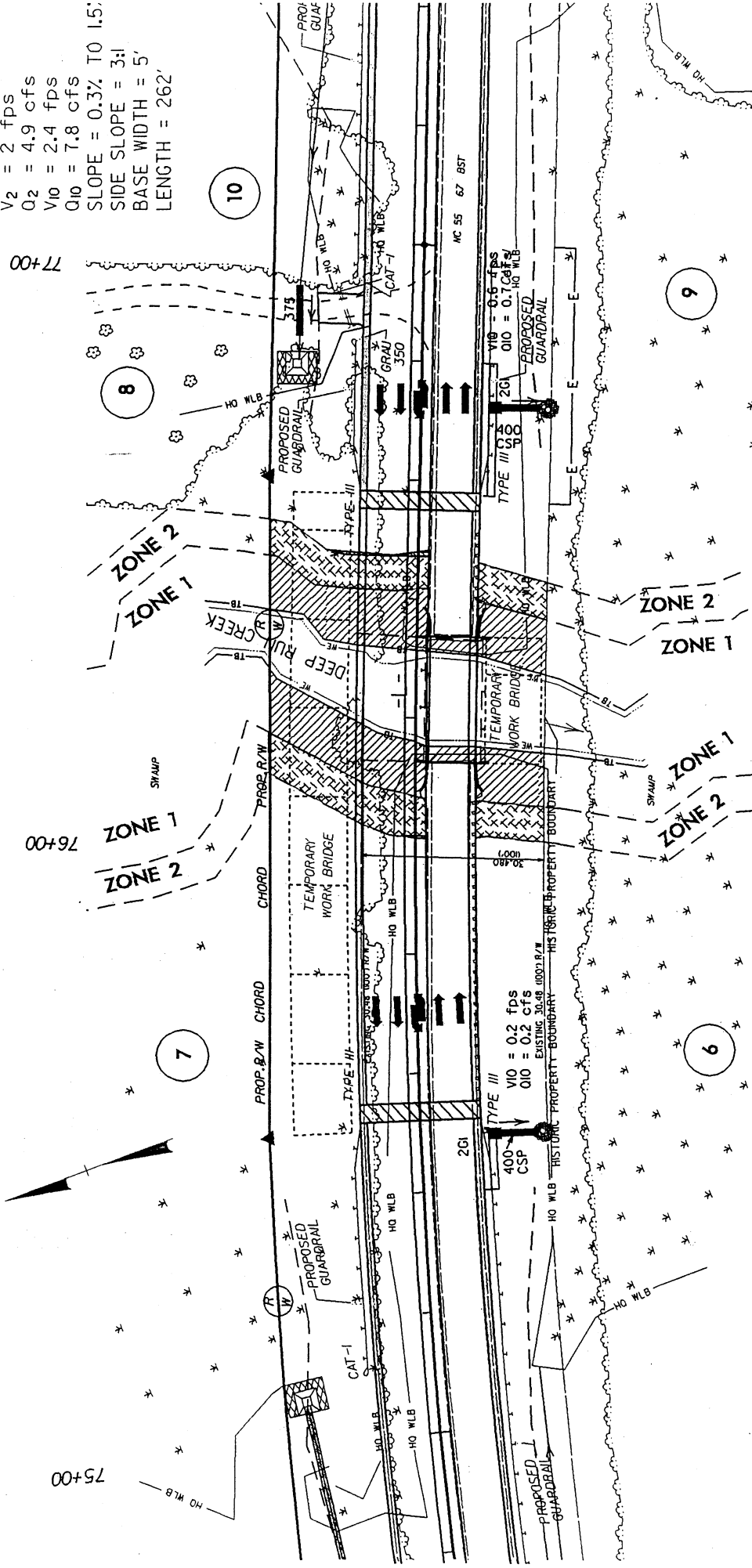

ALLOWABLE IMPACTS ZONE 1
 ALLOWABLE IMPACTS ZONE 2

N.C. DEPT. OF TRANSPORTATION
 DIVISION OF HIGHWAYS
 PAMLICO COUNTY
 PROJECT 8.I170901 (R-2539B)
 NC 55 FROM EAST OF SR 1127 TO EAST
 SR 1129

5 0 10
 SCALE = 1:1000

SHEET **B6** OF 17

7-9-03
 1274872002

SITE 5 -L- STA. 81+85 TO 82+00 RT & LT

GRASS SWALE
 DA = 3.05 AC
 V₂ = 1.7 fps
 Q₂ = 8.8 cfs
 V₁₀ = 2.1 fps
 Q₁₀ = 19.5 cfs
 SLOPE = 0.3% TO 0.46%
 SIDE SLOPE = 3:1
 BASE WIDTH = 5'
 LENGTH = 459'

GRASS SWALE
 DA = 0.45 AC
 V₂ = 1.2 fps
 Q₂ = 0.5 cfs
 V₁₀ = 1.3 fps
 Q₁₀ = 0.8 cfs
 SLOPE = 0.46% TO 2.5%
 SIDE SLOPE = 3:1
 BASE WIDTH = 5'
 LENGTH = 682'

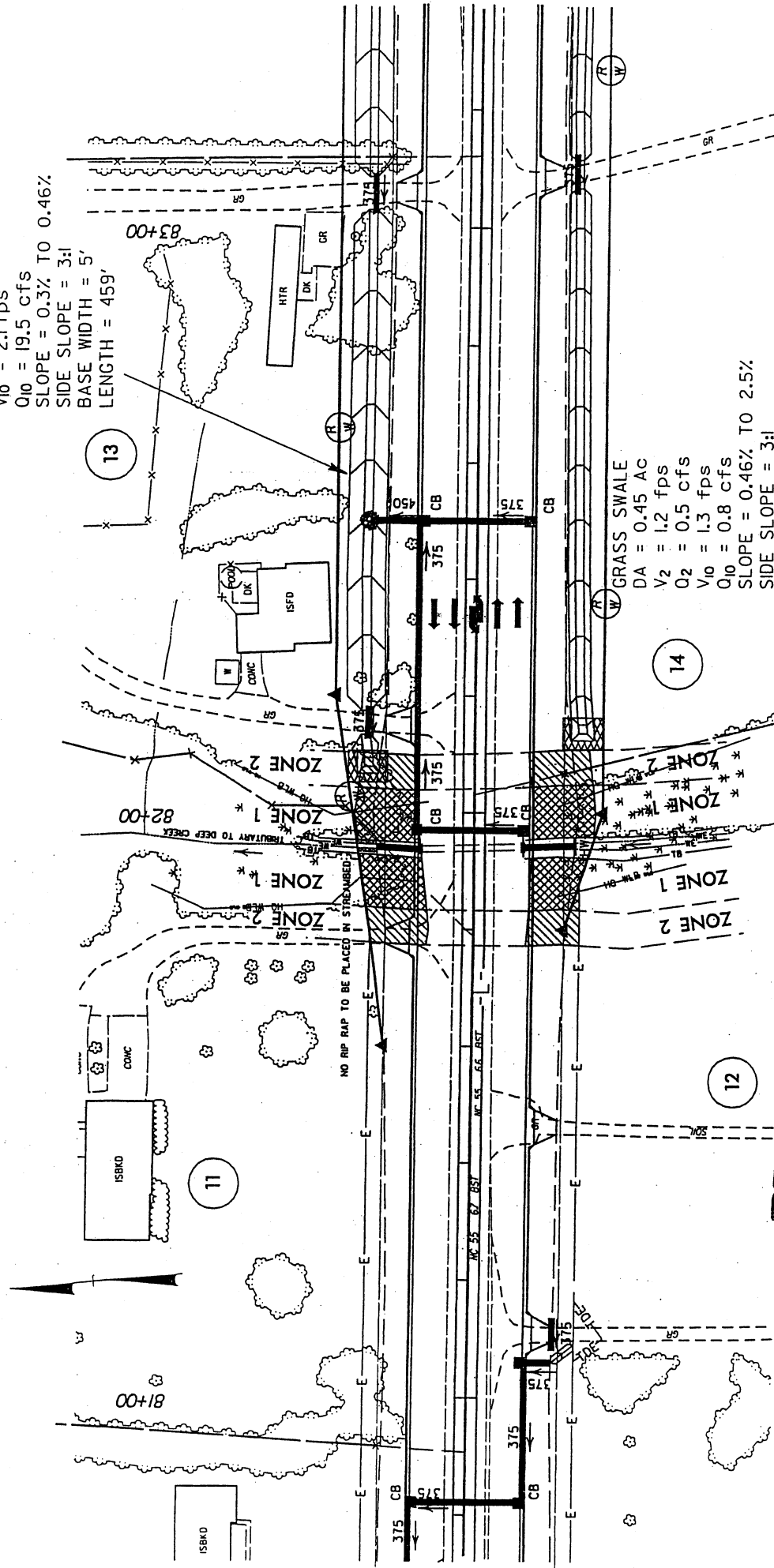

NO RIP RAP TO BE PLACED IN STREAMBED

RECEIVED

OCT 0 8 2003

J.V. OF COASTAL MANAGEMENT
RALEIGH



PERMANENT IMPACT ZONE 1
 PERMANENT IMPACT ZONE 2

N.C. DEPT. OF TRANSPORTATION
 DIVISION OF HIGHWAYS
 PAMLICO COUNTY
 PROJECT 8.II7090I (R-2539B)
 NC 55 FROM EAST OF SR 1127 TO EAST OF SR 1129
 SR 1129
87-rev.
 SHEET OF 12

10/06/2003

SITE 7 -L- STA. 108+50 TO 114+00 RT & LT

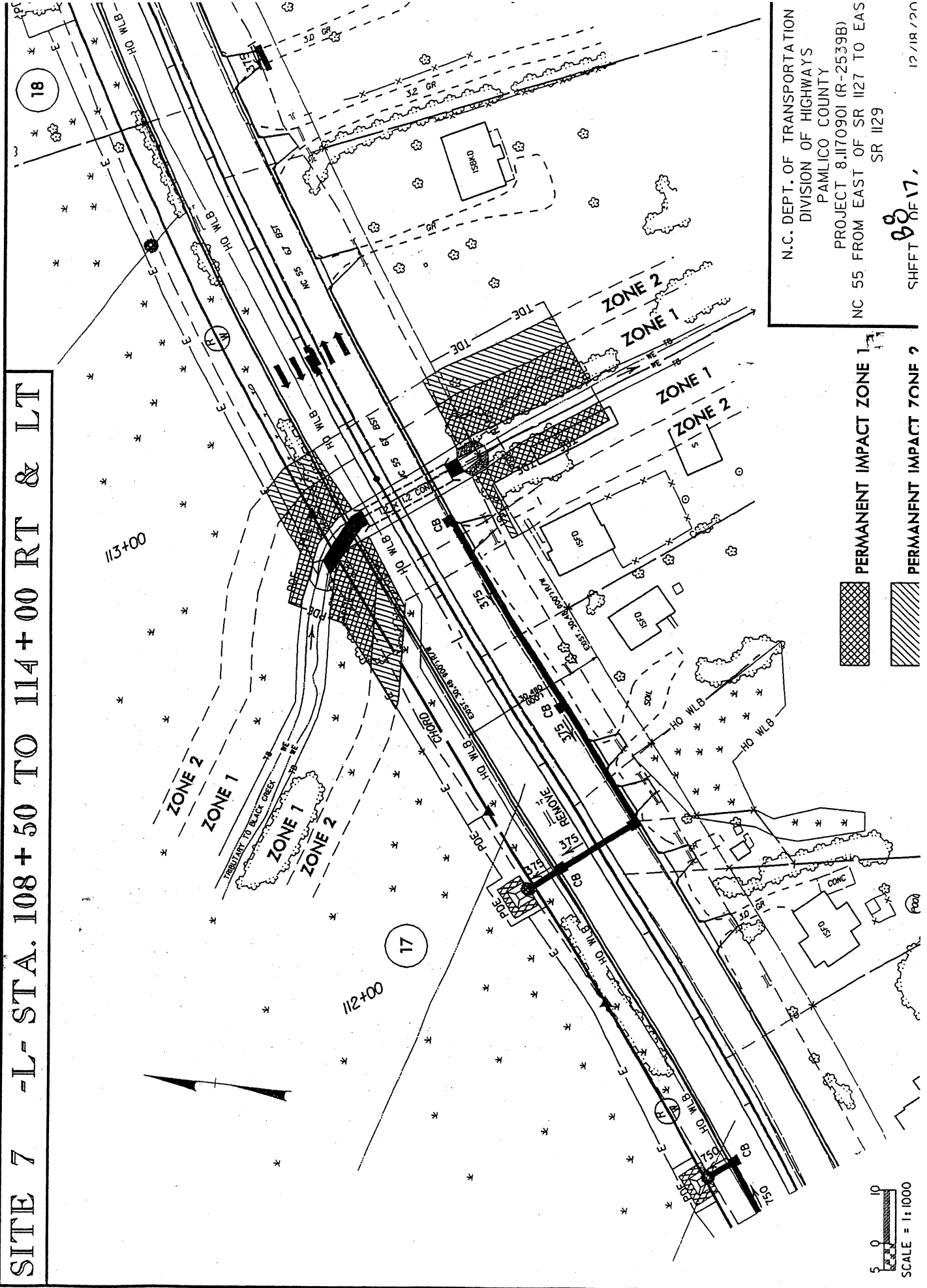

N.C. DEPT. OF TRANSPORTATION
 DIVISION OF HIGHWAYS
 PAMLICO COUNTY
 PROJECT 8.1170901 (R-2539B)
 NC 55 FROM EAST OF SR 1127 TO EAS
 SR 1129

PERMANENT IMPACT ZONE 1
 PERMANENT IMPACT ZONE 2

88 OF 17,
 SHEET 17, 20

SITE 13 -L- STA. 134+75 TO 137+30 RT & LT

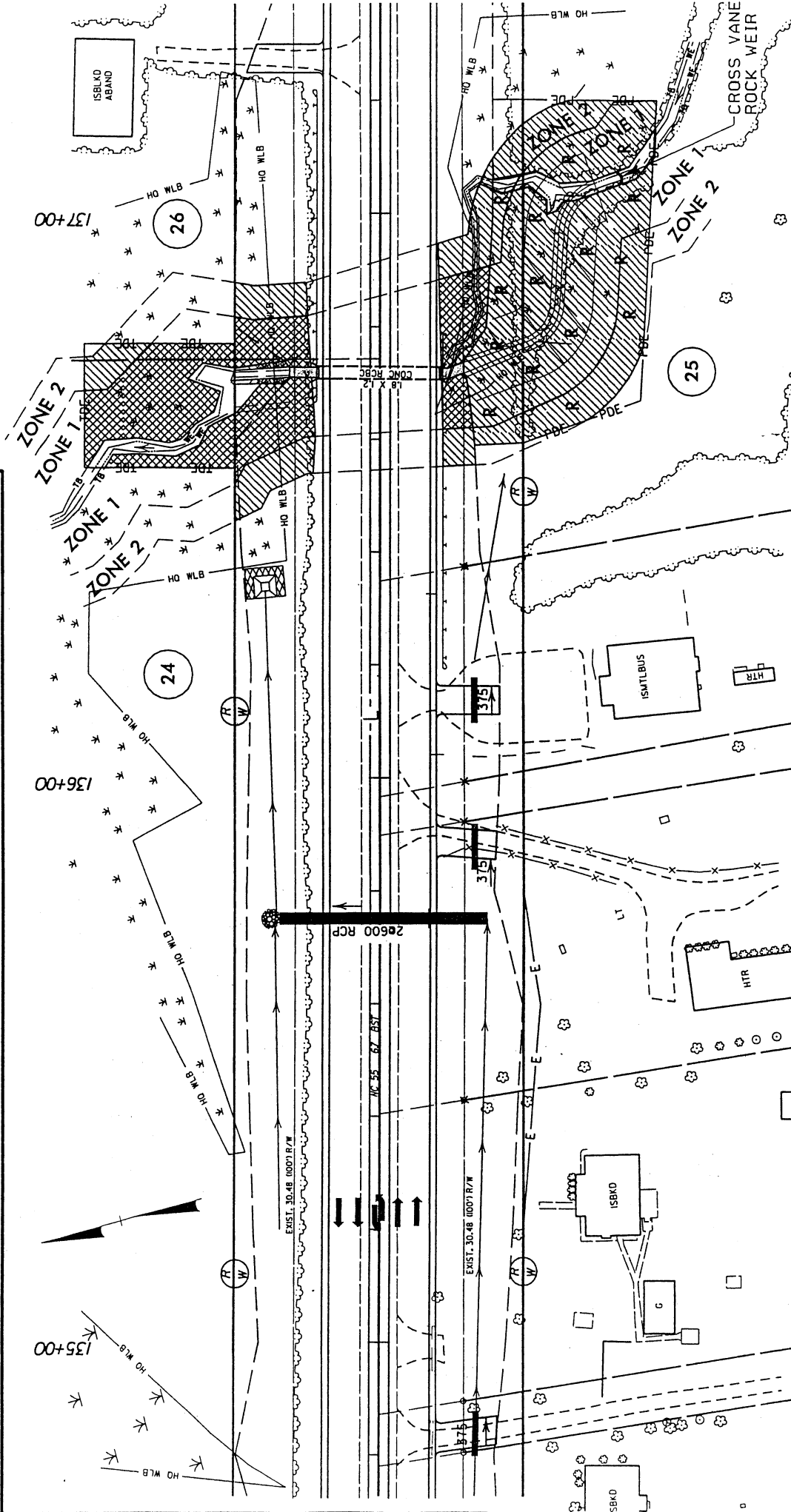

N.C. DEPT. OF TRANSPORTATION
 DIVISION OF HIGHWAYS
 PAMLICO COUNTY
 PROJECT 8.1170901 (R-2539B)
 NC 55 FROM EAST OF SR 1127 TO EAST OF
 SR 1129

PERMANENT IMPACT ZONE 1
 PERMANENT IMPACT ZONE 2

BUFFER REPLACEMENT

SCALE = 1:1000

SHEET 89 OF 12

4/7/2003

SITE 16 -L- STA. 148+10 TO 151+40 RT & LT

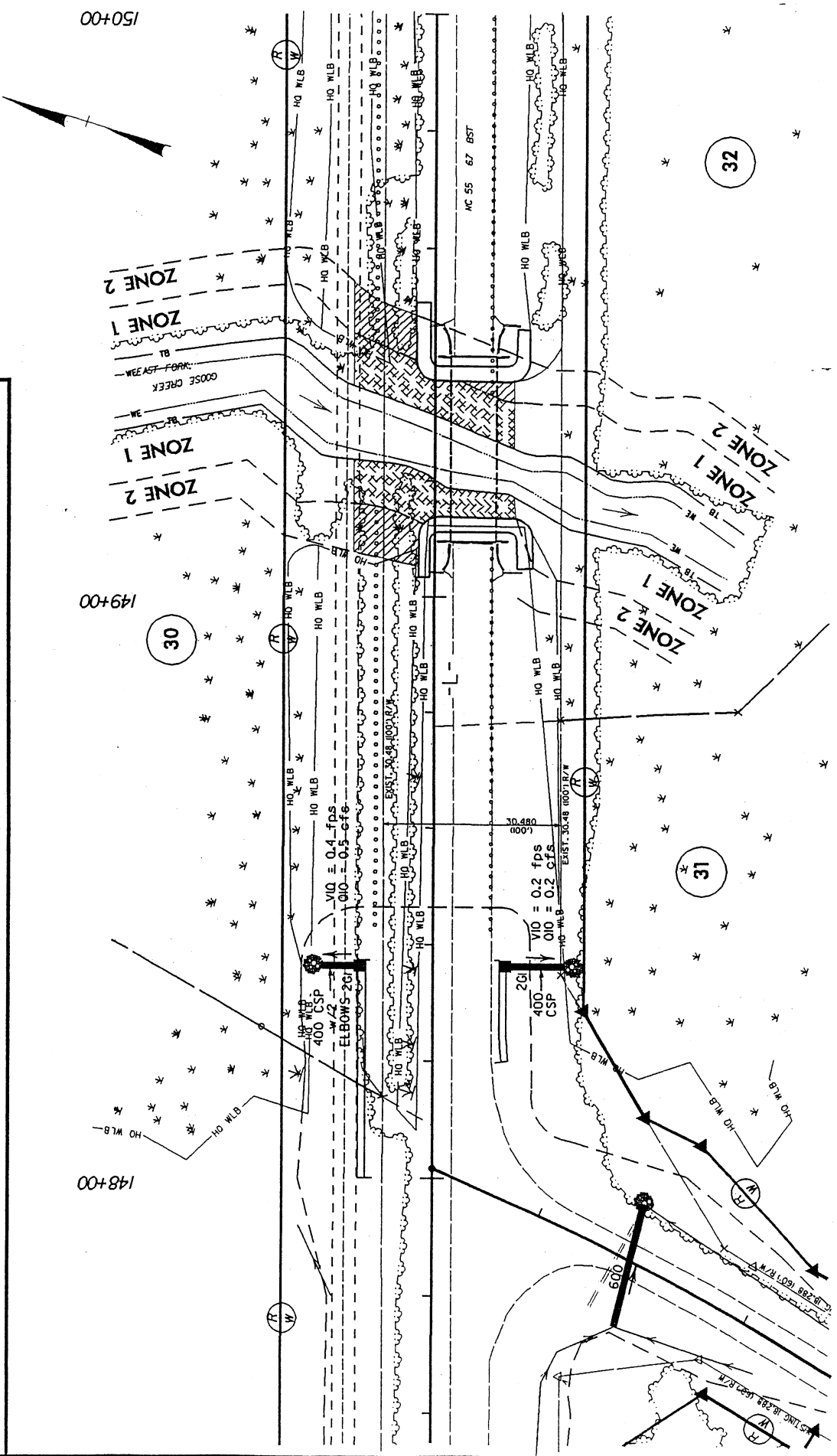

N.C. DEPT. OF TRANSPORTATION
 DIVISION OF HIGHWAYS
 PAMLICO COUNTY
 PROJECT 8.1170901 (R-2539B)
 NC 55 FROM EAST OF SR 1127 TO EAST
 SR 1129

7-9-03
 12-187-2001

ALLOWABLE IMPACTS ZONE 1
 ALLOWABLE IMPACTS ZONE 2

5 0 10
 SCALE = 1:1000

BUFFER IMPACTS SUMMARY

SITE NO.	STRUCTURE SIZE / TYPE	STATION (FROM/TO)	IMPACT								BUFFER REPLACEMENT				
			TYPE		ALLOWABLE		MITIGABLE		ZONE 1	ZONE 2	ZONE 1	ZONE 2			
			ROAD CROSSING	PARALLEL IMPACT	ZONE 1 (ac)	ZONE 2 (ac)	TOTAL (ac)	ZONE 1 (ac)	ZONE 2 (ac)	TOTAL (ac)	(ac)	(ac)			
2	EXTENSION OF 2@ 1650 RCP	-L- Sta 59+70 TO 61+00	X		0.11	0.06	0.17								
4	BRIDGE, 5 SPAN (5@ 20m) = 100m 1143mm PRESTRESSED CONCRETE GIRDERS	-L- Sta 74+85 TO 77+40	X		0.13	0.18	0.31								
5	EXTENSION OF 1050 RCP w/COLLAR	-L- Sta 81+85 TO 82+00	X		0.09	0.06	0.15								
7	EXTENSION OF 1.8 x 1.2 & 1.2 x 1.2 RCBC (TWO CELLS)	-L- Sta 108+50 TO 114+00	X		0.18	0.10	0.27								
13	EXTENSION OF 1.8 x 1.2 RCBC	-L- Sta 134+75 TO 137+30	X		0.21	0.09	0.31						0.33	0.07	
16	BRIDGE, 17 SPAN (6@13m, 1@15m, 10@13m) 533mm CORED SLAB	-L- Sta 148+10 TO 151+40	X		0.09	0.05	0.14								
TOTAL:					0.81	0.54	1.35					0.00	0.33	0.07	

N.C. DEPT. OF TRANSPORTATION
DIVISION OF HIGHWAYS

PAMLICO COUNTY

PROJECT: 8.1170901 (R-2539B)

NC 55 FROM EAST OF SR 1127 TO EAST OF SR 1129

12/18/2002, rev. 7-19-03

SHEET OF 12

B11

BUFFER IMPACTS SUMMARY

SITE NO.	STRUCTURE SIZE / TYPE	STATION (FROM/TO)	IMPACT										BUFFER REPLACEMENT				
			TYPE		ALLOWABLE		MITIGABLE		ZONE 1		ZONE 2		ZONE 1	ZONE 2			
			ROAD CROSSING	PARALLEL IMPACT	ZONE 1 (m ²)	ZONE 2 (m ²)	TOTAL (m ²)	ZONE 1 (m ²)	ZONE 2 (m ²)	TOTAL (m ²)	ZONE 1 (m ²)	ZONE 2 (m ²)	ZONE 1 (m ²)	ZONE 2 (m ²)			
2	EXTENSION OF 2@ 1650 RCP	-L- Sta 59+70 TO 61+00	X		434.9	255.7	690.6										
4	BRIDGE, 5 SPAN (5@ 20m) = 100m 1143mm PRESTRESSED CONCRETE GIRDERS	-L- Sta 74+85 TO 77+40	X		508.4	748.4	1256.8										
5	EXTENSION OF 1050 RCP w/COLLAR	-L- Sta 81+85 TO 82+00	X		372.0	241.0	613.0										
7	EXTENSION OF 1.8 x 1.2 & 1.2 x 1.2 RCBC (TWO CELLS)	-L- Sta 108+50 TO 114+00	X		712.0	388.0	1100.0										
13	EXTENSION OF 1.8 x 1.2 RCBC	-L- Sta 134+75 TO 137+30	X		867.0	374.0	1241.0									1353.0	270.0
16	BRIDGE, 17 SPAN (6@13m, 1@15m, 10@13m) 533mm CORED SLAB	-L- Sta 148+10 TO 151+40	X		384.4	192.2	576.6										
TOTAL:					3278.7	2199.3	5478.0								0.0	1353.0	270.0

N.C. DEPT. OF TRANSPORTATION
DIVISION OF HIGHWAYS

PAMLICO COUNTY

PROJECT: 8.1170901 (R-2539B)

NC 55 FROM EAST OF SR 1127 TO EAST OF SR 1129

12/18/2002, rev. 7-9-03

SHEET OF 12

12

R-2539B
Utility Relocations

Power

CP&L – Power poles located outside of the existing and/or proposed Rights of Way (R/W) will largely remain in place. Poles inside the new R/W will be relocated to 0.3 meters (1 foot) outside the new R/W line. At the staged construction of the bridges over Deep Run Creek and East Fork, Goose Creek, the power will temporarily relocate to the north side of NC 55 during construction of the southern portion of the structures. The power will return to the current alignment after construction. No increase in capacity is expected at this time.

Tideland EMC – Tideland EMC does not have any facilities in conflict with proposed construction in any of the environmentally sensitive areas. Poles will be relocated out of the clear zone or outside the right of way. No increase in capacity is expected at this time.

Telephone

There are copper and fiber optic telephone lines in the shoulders of the existing roadway. These facilities are expected to relocate to the proposed shoulder or to the edge of the proposed cut or fill slopes. Wetlands and buffer zones will be directionally bored with conduit to avoid surface disruptions. No increase in capacity is expected at this time.

Water

There is an eight in water main the length of the project. The water main will be relocated within the permitted footprint of the roadway work. Stream and wetland crossings will be directionally bored to avoid surface disruptions. No increase in capacity is expected at this time.

Sewer

There is an existing sewer from Bennett Tingle Road to the end of the project. This design was coordinated with NCDOT and should not require relocation. If the sewer requires replacement, it will be replaced within the footprint of the roadway project. No increase in capacity is expected at this time.

Utilities
Sheet 01 of 13

SITE 4 -L- STA. 74+85 TO 77+40 RT & LT

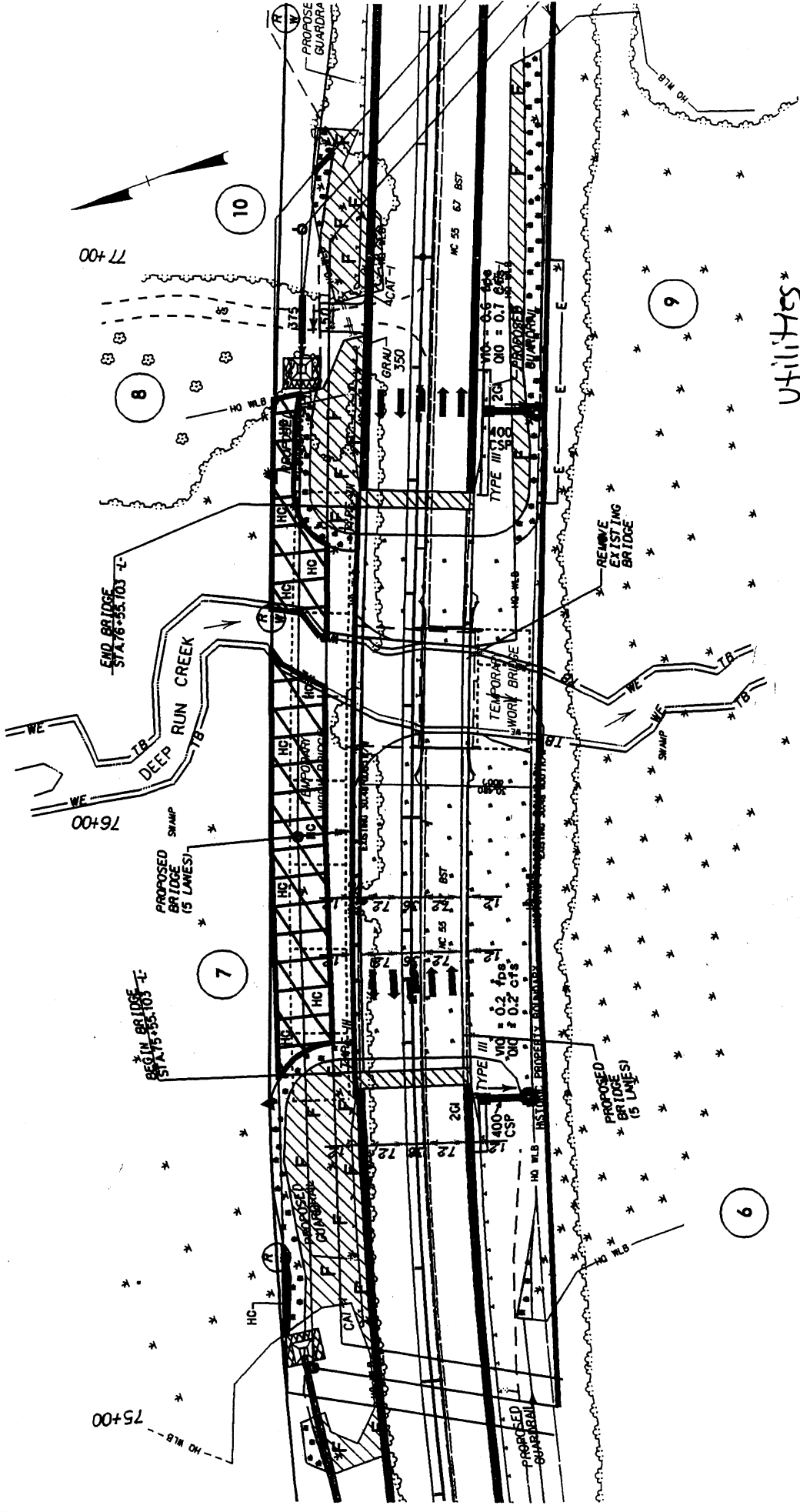

N.C. DEPT. OF TRANSPORTATION
DIVISION OF HIGHWAYS





PAMLICO COUNTY

PROJECT 8-I170901 (R-2539B)
NC 55 FROM EAST OF SR 1127 TO EAST OF
SR 1129

U2 OF 13
SHEET

01/06/2003

UTILITIES *

-  DENOTES WETLAND RESTORATION
-  DENOTES FILL IN WETLAND
-  DENOTES MECHANIZED CLEARING
-  DENOTES HAND CLEARING
-  HISTORIC PROPERTY

SCALE = 1:1000

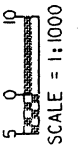

SITE 5 -L- STA. 81+85 TO 82+00 RT & LT

GRASS SWALE
 DA = 3.05 AC
 V₂ = 1.7 fps
 Q₂ = 8.8 cfs
 V₁₀ = 2.1 fps
 Q₁₀ = 19.5 cfs
 SLOPE = 0.3% TO 0.46%
 SIDE SLOPE = 3:1
 BASE WIDTH = 5'
 LENGTH = 459'

GRASS SWALE
 DA = 0.45 AC
 V₂ = 1.2 fps
 Q₂ = 0.5 cfs
 V₁₀ = 1.3 fps
 Q₁₀ = 0.8 cfs
 SLOPE = 0.46% TO 2.5%
 SIDE SLOPE = 3:1
 BASE WIDTH = 5'
 LENGTH = 682'

UTILITIES

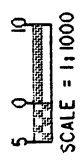
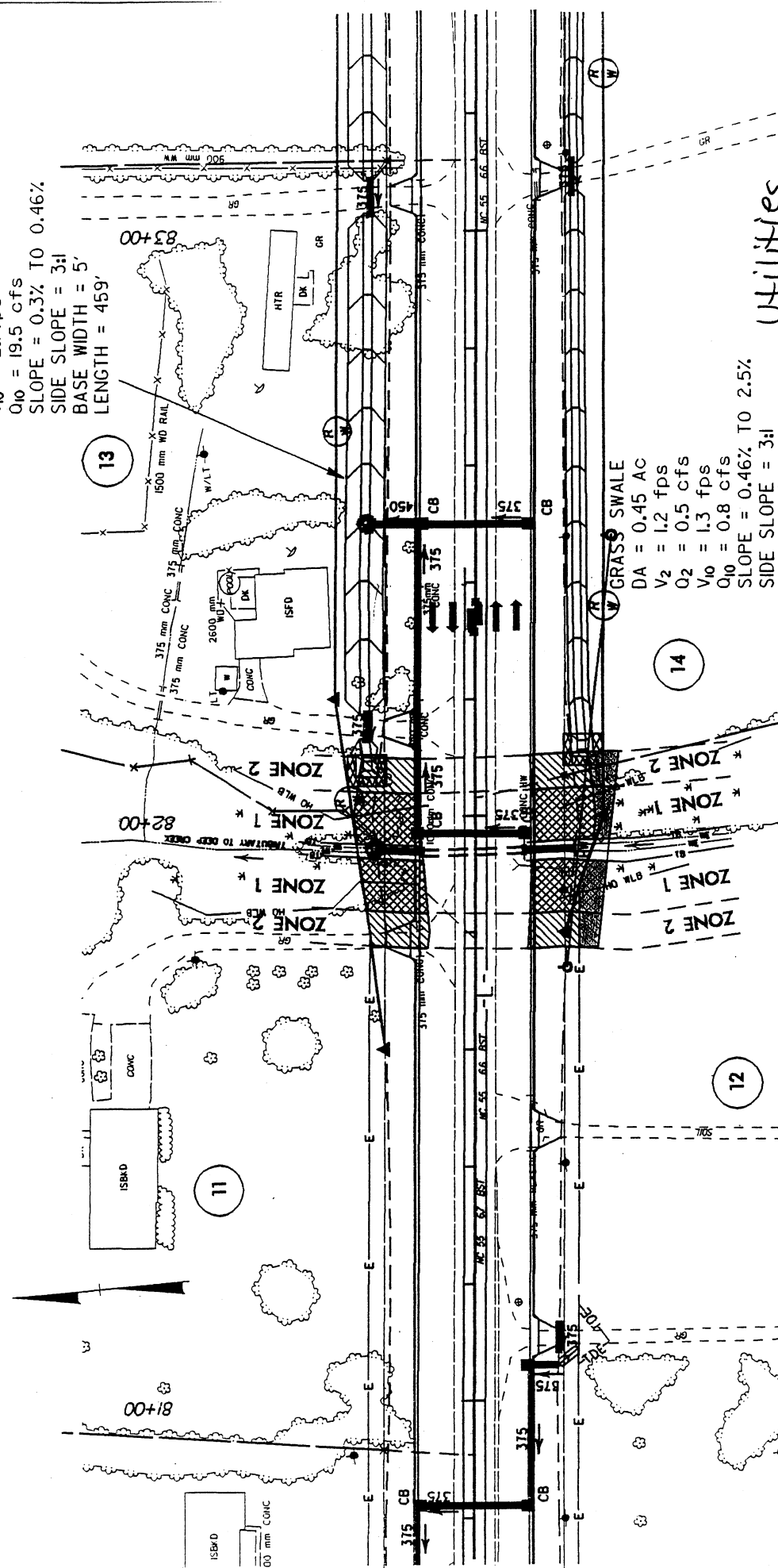

N.C. DEPT. OF TRANSPORTATION
 DIVISION OF HIGHWAYS
 PAMLICO COUNTY
 PROJECT 8.I70901 (R-2539B)
 NC 55 FROM EAST OF SR 1127 TO EAST OF
 SR 1129

SHEET 03 OF 13

1/6/2003

SITE 5 -L- STA. 81+85 TO 82+00 RT & LT

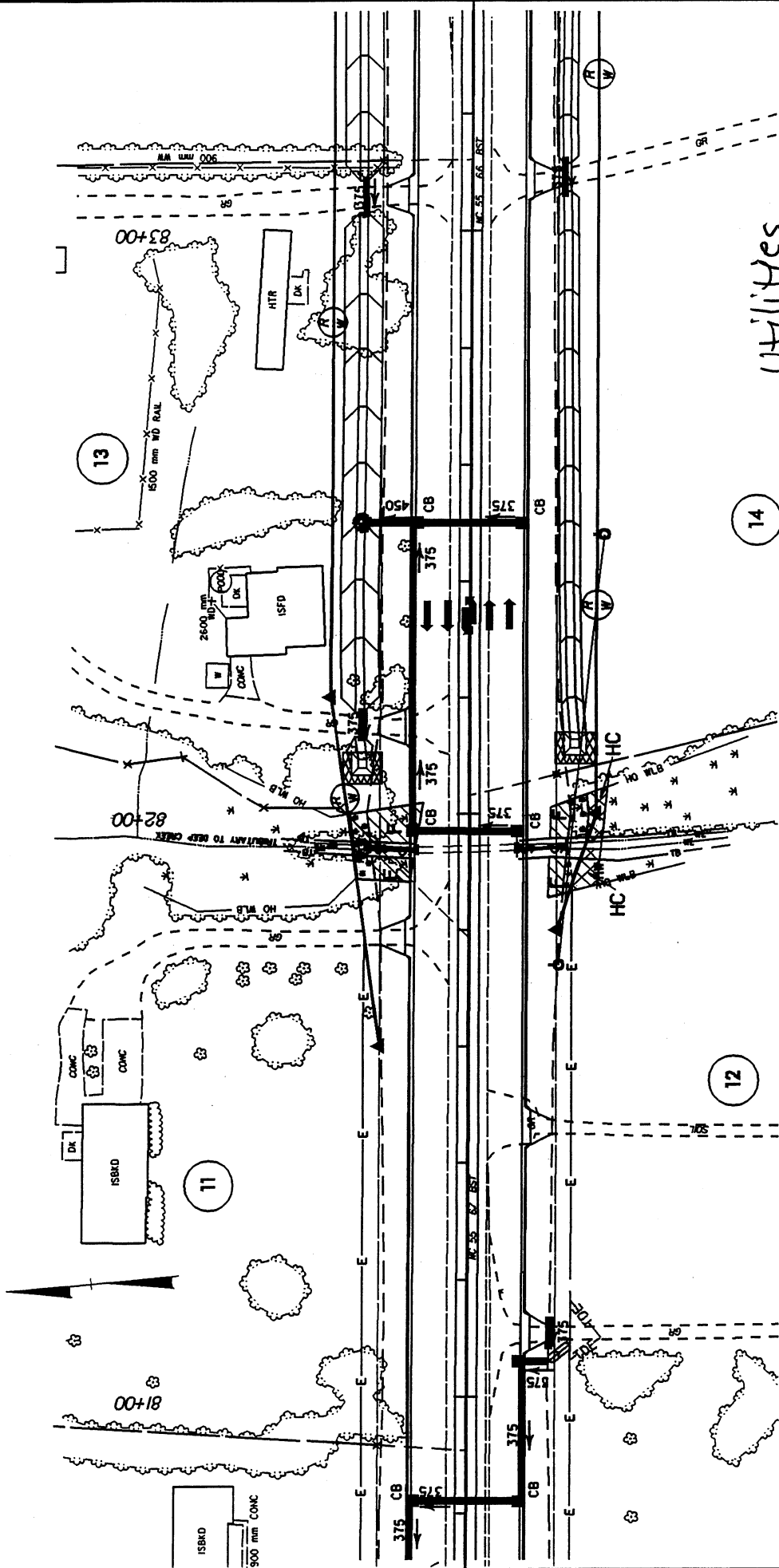

14

- DENOTES FILL IN WETLAND
- DENOTES FILL IN SURFACE WATER
- DENOTES MECHANIZED CLEARING

12

- DENOTES HAND CLEARING



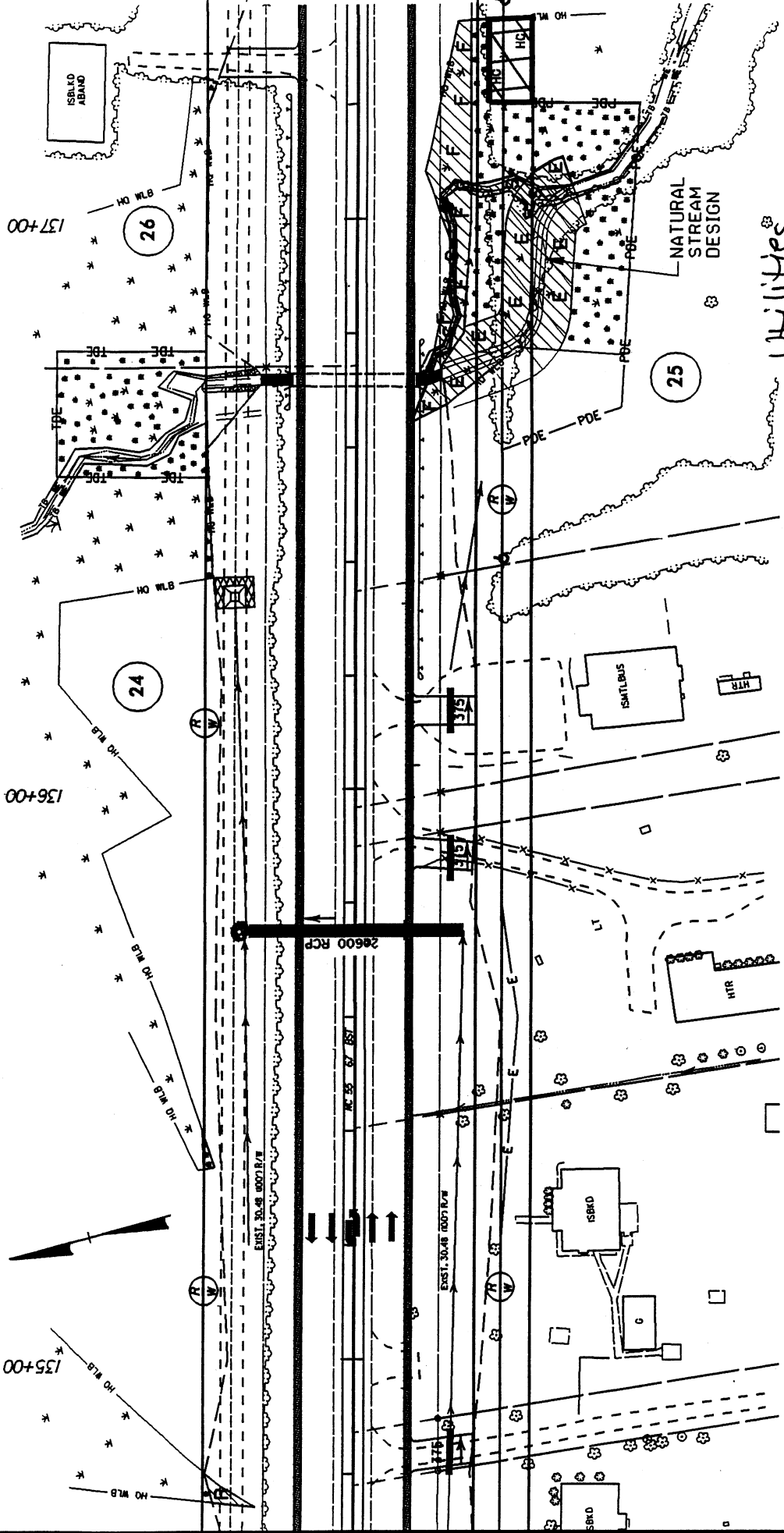

Utilities

N.C. DEPT. OF TRANSPORTATION
 DIVISION OF HIGHWAYS
 PAMLICO COUNTY
 PROJECT 8.I170901 (R-2539B)
 NC 55 FROM EAST OF SR 1127 TO EAST OF
 SR 1129
 SHEET 04 OF 13
 01/06/2003

SITE 13 - L- STA. 134+75 TO 137+30 RT & LT

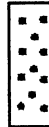

N.C. DEPT. OF TRANSPORTATION
 DIVISION OF HIGHWAYS
 PAMLICO COUNTY
 PROJECT 8.1170901 (R-2539B)
 NC 55 FROM EAST OF SR 1127 TO EAST OF
 SR 1129
 SHEET **05** OF **13**
 01/06/2003

-  DENOTES FILL IN SURFACE WATER
-  DENOTES EXCAVATION IN WETLAND
-  DENOTES MECHANIZED CLEARING
-  DENOTES HAND-CLEARING IN WETLAND
-  DENOTES FILL IN WETLAND

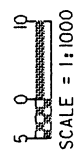

SITE 13 - L- STA. 134+75 TO 137+30 RT & LT

UTILITY IMPACTS TO EXISTING BUFFER ZONES

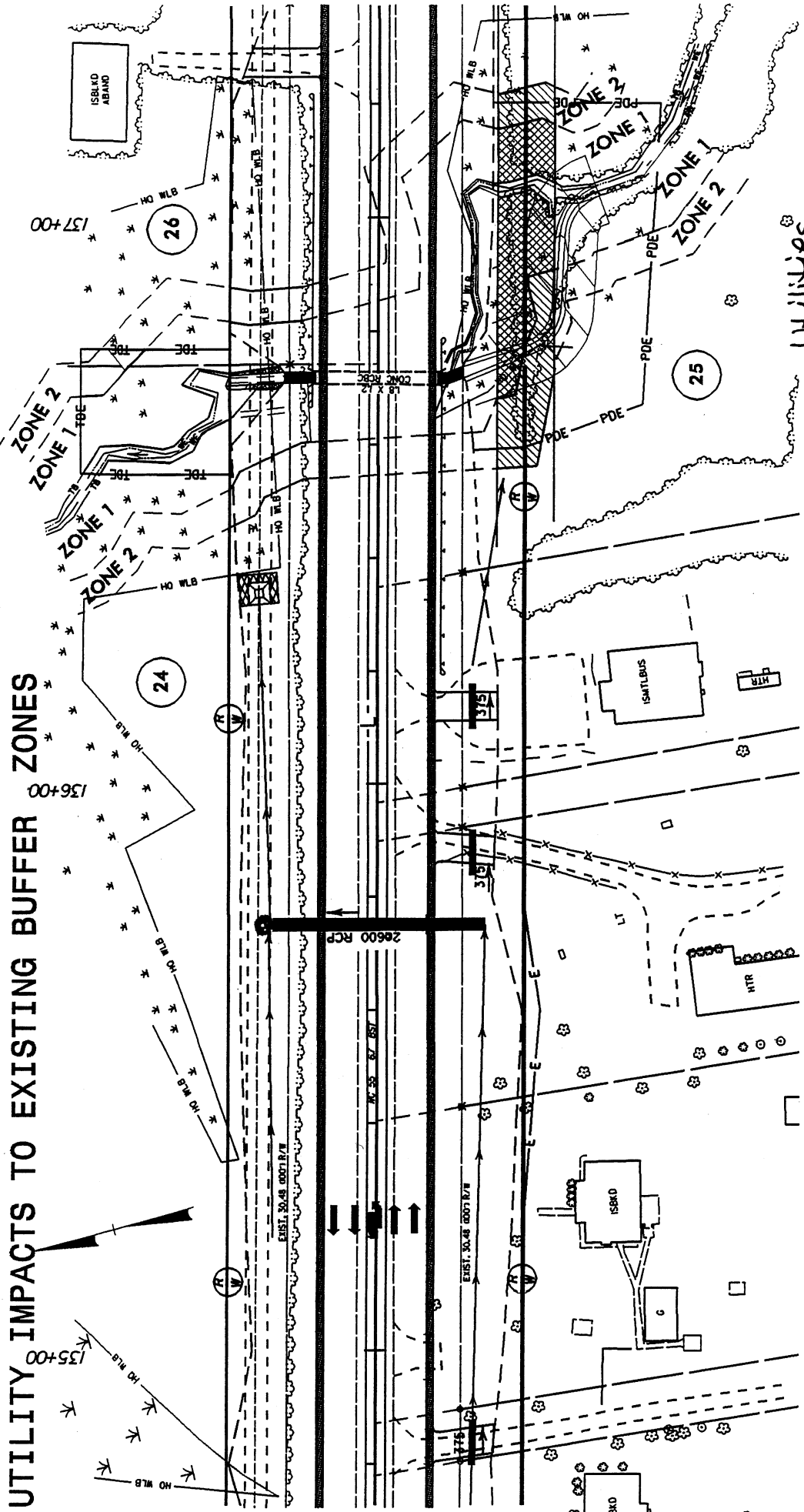

N.C. DEPT. OF TRANSPORTATION
 DIVISION OF HIGHWAYS
 PAMLICO COUNTY
 PROJECT 8.II70901 (R-2539B)
 NC 55 FROM EAST OF SR 1127 TO EAST OF
 SR 1129

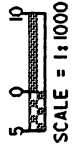



U6
 SHEET OF 13

1/6/2003

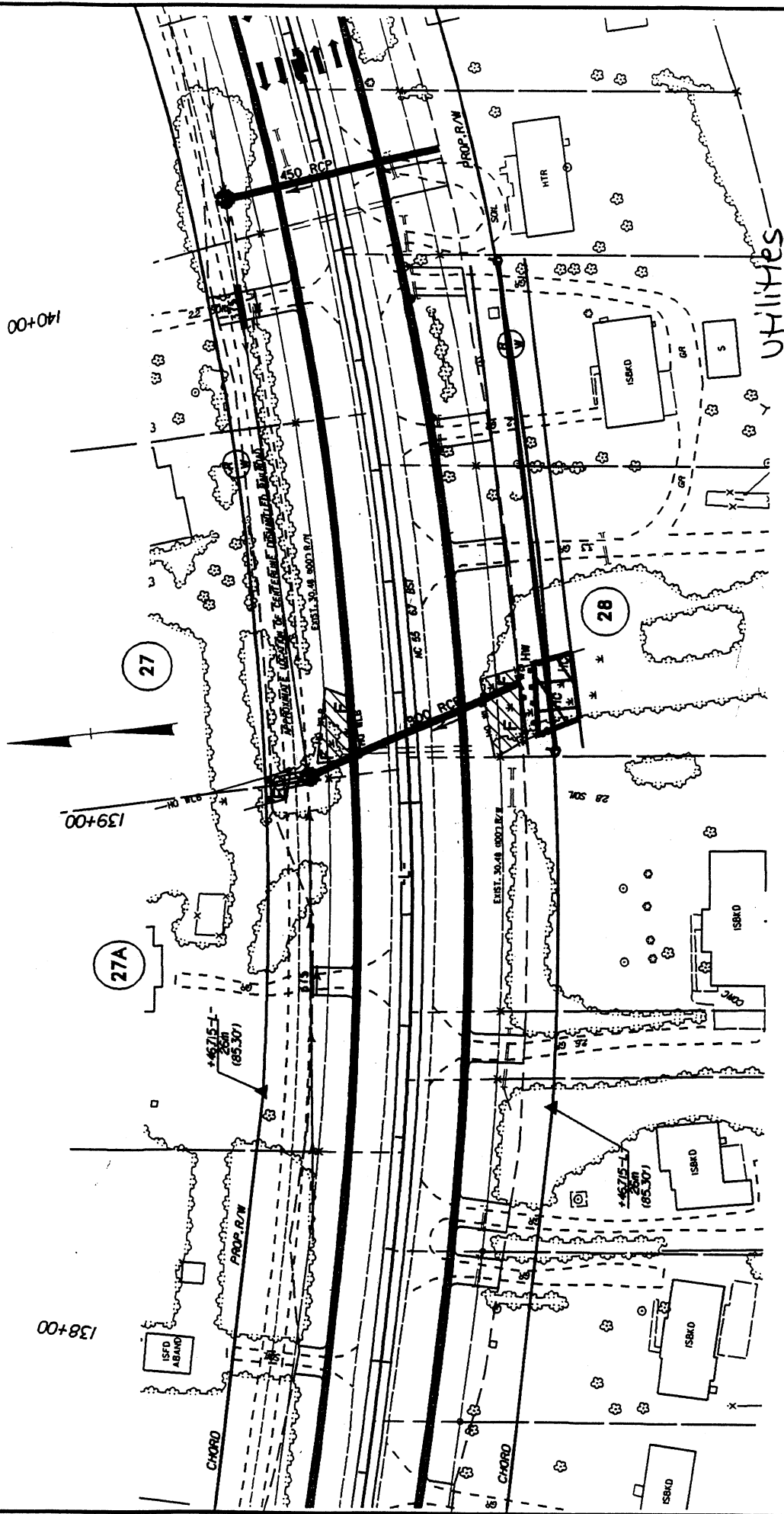
SITE 14 -L- STA. 139+10 TO 139+20 RT & LT



N.C. DEPT. OF TRANSPORTATION
 DIVISION OF HIGHWAYS
 PAMLICO COUNTY
 PROJECT 8.1170901 (R-2539B)
 NC 55 FROM EAST OF SR 1127 TO EAST OF
 SR 1129
 SHEET 13 OF 13

 DENOTES FILL IN WETLAND
 DENOTES EXCAVATION IN WETLAND
 DENOTES MECHANIZED CLEARING

 DENOTES HAND-CLEARING IN WETLAND

 SCALE = 1:1000

SITE 16 -L- STA. 148+10 TO 151+40 RT & LT

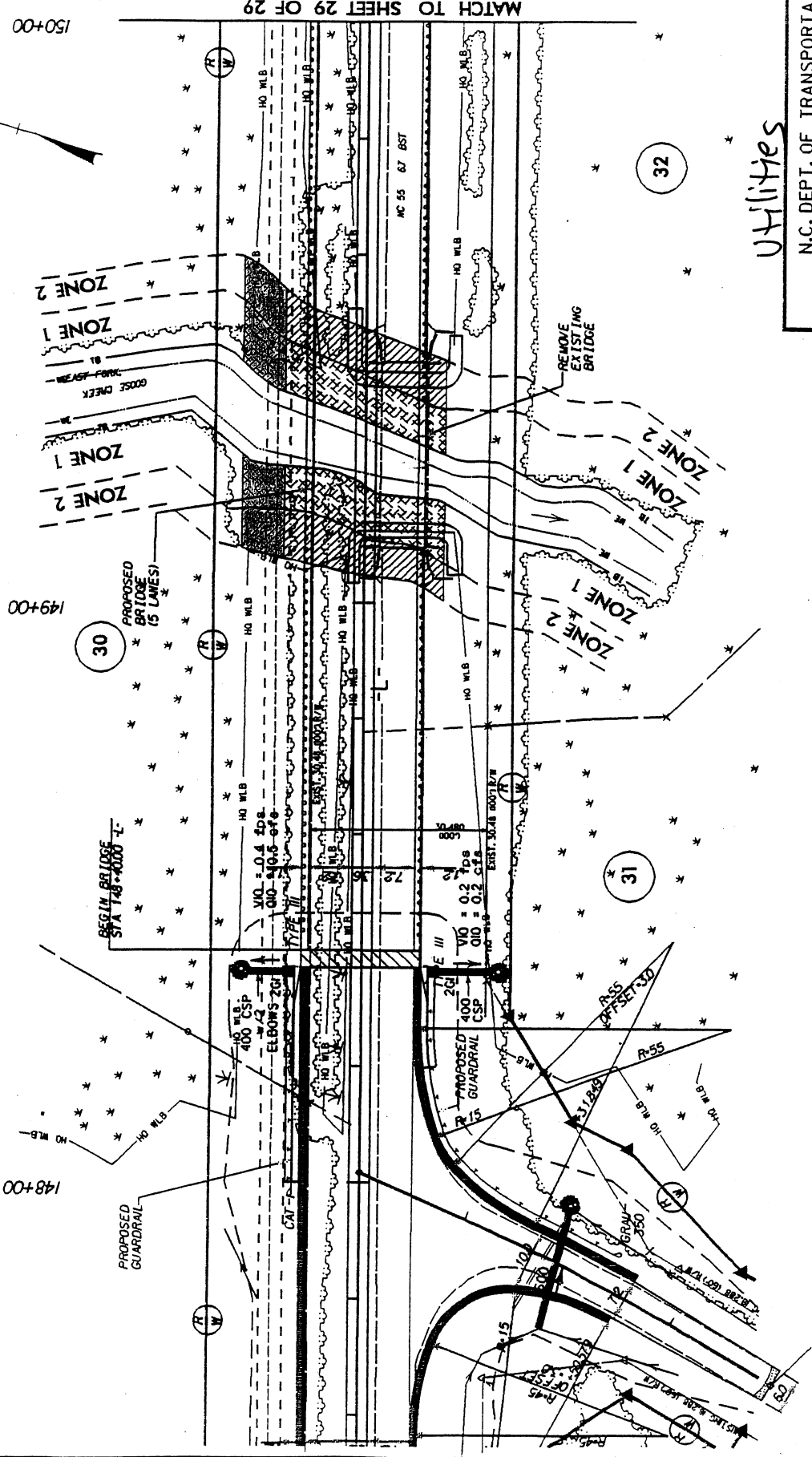

MATCH TO SHEET 29 OF 29

150+00

149+00

148+00

UTILITIES

N.C. DEPT. OF TRANSPORTATION
 DIVISION OF HIGHWAYS
 PAMLICO COUNTY
 PROJECT 8.II7090I (R-25398)
 NC 55 FROM EAST OF SR II27 TO EAST OF
 SR II29
 SR II29

13

SHEET OF 13

1/6/2003

- ALLOWABLE IMPACTS ZONE 1
- ALLOWABLE IMPACTS ZONE 2

5 0 10



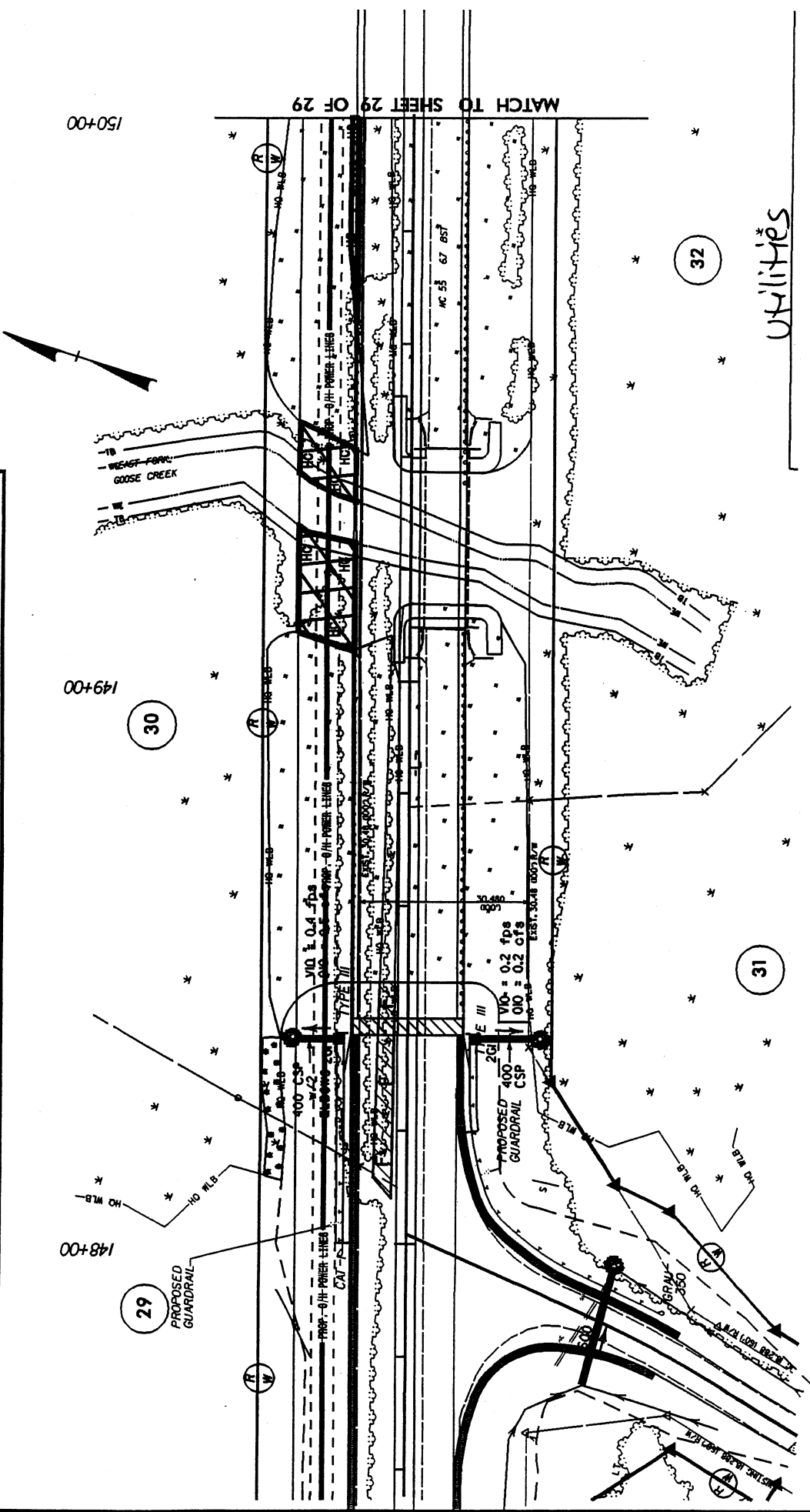

 SCALE = 1:11,000

SITE 16 - L- STA. 148+10 TO 151+40 RT & LT



N.C. DEPT. OF TRANSPORTATION
 DIVISION OF HIGHWAYS
 PAMLICO COUNTY
 PROJECT 8.IIT0901 (R-2539B)
 NC 55 FROM EAST OF SR 1127 TO EAST OF
 SR 1129
 SR 1129

UTILITIES

-  DENOTES WETLAND RESTORATION
-  DENOTES FILL IN WETLAND
-  DENOTES MECHANIZED CLEARING
-  DENOTES HAND-CLEARING IN WETLAND

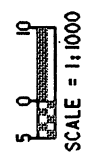

u9
 SHEET OF 13
 1/6/2003

SITE 16 -L- STA. 148+10 TO 151+40 RT & LT

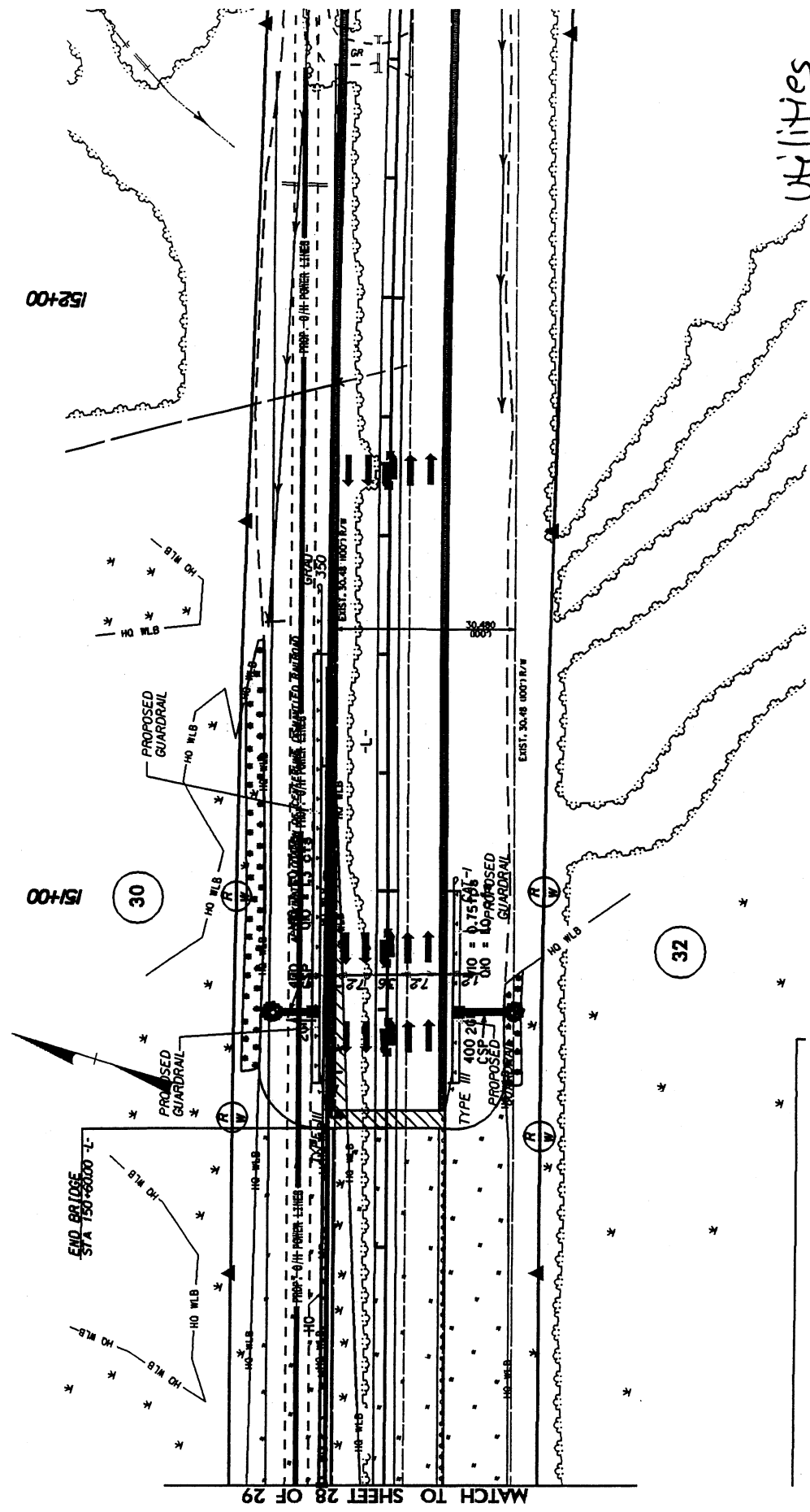

N.C. DEPT. OF TRANSPORTATION
 DIVISION OF HIGHWAYS
 PAMLICO COUNTY
 PROJECT 8JIT0901 (R-2539B)
 NC 55 FROM EAST OF SR 1127 TO EAST OF
 SR 1129
 SHEET 110 OF 13
 1/6/2003

- DENOTES WETLAND RESTORATION
- DENOTES FILL IN WETLAND
- DENOTES MECHANIZED CLEARING

DENOTES HAND-CLEARING IN WETLAND

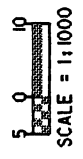

WETLAND PERMIT IMPACT SUMMARY

Site No.	Station (From/To)	Structure Size / Type	WETLAND IMPACTS					SURFACE WATER IMPACTS								
			Fill In Wetlands (ha)	Temp. Fill In Wetlands (ha)	Excavation In Wetlands (ha)	Hand Clearing (Utilities) (ha)	Mechanized Clearing (Method III) (ha)	Fill In SW (Natural) (ha)	Fill In SW (Pond) (ha)	Temp. Fill In SW (ha)	Existing Channel Impacted (m)	Natural Stream Design (m)				
1	56+30 TO 56+55				0.034			0.008								
2	59+70 TO 61+00	EXTENSION OF 2@ 1650 RCP w/COLLARS	0.051		0.012		0.019		0.004				22			
3	62+25 TO 63+60		0.055				0.010									
*4	74+85 TO 77+40	BRIDGE: 5 SPAN (5@ 20m) = 100m 1143mm PRESTRESSED CONCRETE GIRDERS	0.136	0.003		0.094	0.061									
5	81+85 TO 82+00	EXTENSION OF 1050 RCP w/COLLARS	0.012			0.005	0.005		0.001				16			
6	102+35 TO 103+65		0.047				0.038									
7	108+50 TO 114+00	EXTENSION OF 1.8 x 1.2 & 1.2 x 1.2 RCBC (TWO CELLS)	0.286				0.178		0.003				16			
8	117+20 TO 118+60		0.008				0.038									
9	119+20 TO 120+20		0.020				0.023									
10	121+70 TO 122+20		0.045				0.013									
11	123+75 TO 125+60		0.021				0.017									
13	134+75 TO 137+30	EXTENSION OF 1.8 x 1.2 RCBC	0.027		0.048	0.012	0.132		0.006				36		41	
14	139+10 TO 139+20		0.017		0.002	0.009	0.004									
15	145+35 TO 146+75		0.000				0.035									
**16	148+10 TO 151+40	BRIDGE: 17 SPAN (6@ 13m, 1@ 15m, 10@ 13m) = 223m 533mm CORED SLAB	0.030			0.038	0.034									
TOTALS:			0.754	0.003	0.095	0.158	0.614	0.014	0.000	0.000	0.000	0.000	90		41	

* SITE NO. 4 - EXISTING ROAD REMOVED, RECLAIMED WETLAND = 0.234 (ha)

** SITE NO. 16 - EXISTING ROAD AND RAILROAD EMBANKMENT REMOVED; RECLAIMED WETLAND = 0.754 (ha)

Utilities

N.C. DEPT. OF TRANSPORTATION
DIVISION OF HIGHWAYS

PAMILCO COUNTY

PROJECT 8.1170901 (R-2539B)
NC 55 FROM EAST OF SR 1127 TO EAST OF SR 1129

Sheet 13
SHEET OF 16

UTILITY IMPACTS SUMMARY (UTILITIES ONLY)

SITE NO.	STRUCTURE SIZE / TYPE	STATION (FROM/TO)	IMPACT										BUFFER REPLACEMENT				
			TYPE		ALLOWABLE			MITIGABLE			ZONE 1		ZONE 2				
			ROAD CROSSING	PARALLEL IMPACT	ZONE 1 (ac)	ZONE 2 (ac)	TOTAL (ac)	ZONE 1 (ac)	ZONE 2 (ac)	TOTAL (ac)	ZONE 1 (ac)	ZONE 2 (ac)					
2	EXTENSION OF 2@ 1650 RCP	-L- Sta 59+70 TO 61+00	X		0.00	0.00	0.00										
4	BRIDGE, 5 SPAN (5@ 20m) = 100m 1143mm PRESTRESSED CONCRETE GIRDERS	-L- Sta 74+85 TO 77+40	X		0.00	0.00	0.00										
5	EXTENSION OF 1050 RCP w/COLLAR	-L- Sta 81+85 TO 82+00	X		0.01	0.01	0.03										
7	EXTENSION OF 1.8 x 1.2 & 1.2 x 1.2 RCBC (TWO CELLS)	-L- Sta 108+50 TO 114+00	X		0.00	0.00	0.00										
13	EXTENSION OF 1.8 x 1.2 RCBC	-L- Sta 134+75 TO 137+30	X		0.09	0.07	0.15										
16	BRIDGE, 17 SPAN (6@13m, 1@15m, 10@13m) 533mm CORED SLAB	-L- Sta 148+10 TO 151+40	X		0.08	0.06	0.14										
TOTAL:					0.18	0.14	0.32								0.00	0.00	0.00

UTILITIES
N.C. DEPT. OF TRANSPORTATION
DIVISION OF HIGHWAYS

PAMLICO COUNTY
PROJECT: 8.1170901 (R-2539B)
NC 55 FROM EAST OF SR 1127 TO EAST OF SR 1129

12/18/2002
SHEET OF 13
012

BUFFER IMPACTS SUMMARY (UTILITIES ONLY)

SITE NO.	STRUCTURE SIZE / TYPE	STATION (FROM/TO)	IMPACT												
			TYPE		ALLOWABLE		MITIGABLE		BUFFER REPLACEMENT						
			ROAD CROSSING	PARALLEL IMPACT	ZONE 1 (m ²)	ZONE 2 (m ²)	TOTAL (m ²)	ZONE 1 (m ²)	ZONE 2 (m ²)	TOTAL (m ²)	ZONE 1 (m ²)	ZONE 2 (m ²)			
2	EXTENSION OF 2@ 1650 RCP	-L- Sta 59+70 TO 61+00	X				0.0								
4	BRIDGE, 5 SPAN (5@ 20m) = 100m 1143mm PRESTRESSED CONCRETE GIRDERS	-L- Sta 74+85 TO 77+40	X				0.0								
5	EXTENSION OF 1050 RCP w/COLLAR	-L- Sta 81+85 TO 82+00	X		60.7	46.5	107.2								
7	EXTENSION OF 1.8 x 1.2 & 1.2 x 1.2 RCBC (TWO CELLS)	-L- Sta 108+50 TO 114+00	X				0.0								
13	EXTENSION OF 1.8 x 1.2 RCBC	-L- Sta 134+75 TO 137+30	X		344.0	268.5	612.5								
16	BRIDGE, 17 SPAN (6@13m, 10@15m, 10@13m) 533mm CORED SLAB	-L- Sta 148+10 TO 151+40	X		319.0	244.7	563.7								
TOTAL:					723.7	559.7	1283.4							0.0	0.0

Note: buffer impacts are for Utilities only and are not part of the Road Crossing impacts.

Utilities
 N.C. DEPT. OF TRANSPORTATION
 DIVISION OF HIGHWAYS
 PAMILCO COUNTY
 PROJECT: 8.1170901 (R-25398B)
 NC 55 FROM EAST OF SR 1127 TO EAST OF SR 1129

1/6/03
 SHEET OF 13

U13