



STATE OF NORTH CAROLINA
DEPARTMENT OF TRANSPORTATION

MICHAEL F. EASLEY
GOVERNOR

LYNDO TIPPETT
SECRETARY

July 18, 2003

MEMORANDUM TO: Mr. W. F. Rosser, P.E.
Division 8 Engineer

FROM: *PSH* Philip S. Harris, III, P.E., Manager *PSH/mox*
Office of the Natural Environment
Project Development and
Environmental Analysis Branch

SUBJECT: Richmond and Montgomery Counties, US 220 Bypass from
South of SR 1448 to SR 2204; State Work Order Number
8.T550803; T.I.P. Number R-2231

Attached are the U. S. Army Corps of Engineers Individual permit and the Division of Water Quality 401 for the construction of the above referenced project. All environmental permits have been received for the construction of this project.

PSH/eah

Attachment

cc: Ms. Debbie Barbour, P.E.
Mr. Omar Sultan
Mr. Jay Bennett, P.E.
Mr. David Chang, P.E.
Mr. Randy Garris, P.E.
Mr. Greg Perfetti, P.E.
Mr. Mark Staley
Mr. John F. Sullivan, III, FHWA
Mr. Art King, Division 8 Environmental Officer

PROJECT COMMITMENTS

**US 220 BYPASS FROM SOUTH OF SR 1448 TO SR 2204
in Montgomery and Richmond Counties
State Project Number 8.1550801
Federal Aid Project Number F-45-1(42)
TIP No. R-2231**

In addition to the standard Section 404 Permit General Conditions and Section 401 Water Quality Certification (WQC) Conditions the following special commitments have been agreed to by NCDOT.

Commitments Developed through Project Development and Design

1. Roadside Environmental Branch, PDEA Branch, Hydrology Unit

NCDOT will minimize long-term water quality impacts through the use of the NCDOT "Best Management Practices for Protection of Surface Waters". **Standard Environmental Commitment**

The more stringent erosion control measures required by Rule 0.0201(d)(2)(A) and (B) of 15 NCAC 213.0201 will be followed within the Naked Creek and Rock Ford Branch Watershed (outstanding resource waters) crossed by the Preferred Alternative. **Standard Environmental Commitment for areas with outstanding resource waters.**

2. Roadway Design Unit, PDEA Branch

The Preferred Alternative will be designed to avoid or minimize to the extent practicable the jurisdictional wetlands delineated within the corridor. **The project team concurred on May 24, 2000, that the avoidance and minimization requirements required by the Section 404(b)(1) guidelines are satisfied.**

3. PDEA Branch

The wetland mitigation plan will be developed in consultation with the appropriate regulatory agencies. **A plan for wetland and stream mitigation was submitted as a portion of the Section 404 Permit application. The plan includes both Riverine and non-Riverine wetland restoration and both on-site and off-site stream restoration and enhancement. A table showing impacts of the project and proposed compensatory mitigation is attached as Appendix B.**

4. Roadway Design Unit, Hydrology Unit, Roadside Environmental Branch

NCDOT will construct a hazardous spill catch basin at the Rocky Ford Branch crossing (Wetland 'Z') and at the crossing of the Naked Creek Tributary northeast of Norman (Wetland 'S'). **Hazardous spill catch basins are included in the final designs.**

5. Geotechnical Unit

Underground storage tank sites will be avoided to the extent practicable. Where sites can not be avoided, testing and removal will be accomplished in accordance with 40 CFR Part 280 and I SA NCAC 2.2(n). Any required site remediation will be accomplished in accordance with NC Department of Environment, Health and Natural Resources "Guidelines for Remediation of Soil Contaminated by Petroleum". **Standard environmental commitment.**

Commitments Developed through Permitting

O.N.E

1. The NCDOT shall mitigate for 423 linear feet of unavoidable impacts to an unnamed tributary to Big Mountain Creek (Section CB, Impact Site #3), an important stream channel, by completing 423 linear feet of onsite stream relocation. The NCDOT shall mitigate for 253 linear feet of unavoidable impacts to an unnamed tributary to Big Mountain Creek (Section CB, Impact Site #6), an important stream channel, by completing 253 linear feet of onsite stream relocation. NCDOT shall consult with NCWRC on all stream relocations and implement all practicable recommendations in the design of specific site requirements for re-establishment of bank vegetation, and placement of meanders and habitat structures. Vegetation shall be used to the maximum extent practicable to stabilize banks, and riprap and other man-made structural measures shall be minimized.

O.N.E, Division 8 Construction

2. The NCDOT shall construct all channel relocations in a dry work area. The NCDOT shall stabilize the relocated channel before stream flows are directed into the new channel. Whenever possible, channel relocations shall be allowed to stabilize for an entire growing season. Upon completion of the project, an as-built channel survey shall be conducted. It is recommended that stream surveys, for both project construction and project monitoring, follow the methodology contained in the USDA Forest Service Manual, *Stream Channel Reference Sites* (Harrelson, et al, 1994). The survey should document the dimension, pattern and profile of the relocated channel.

3. The NCDOT shall identify a stable reference reach that is close to the proposed relocation site and will not be impacted by the proposed highway construction. The NCDOT will coordinate a field meeting with the Corps of Engineers to approve the reference reach selection prior to channel design and relocation of the existing stream. Baseline data on the reference reach channel dimension, pattern, and profile shall be collected and used as a blueprint for the relocation channel design. A detailed design plan of the relocation stream shall be submitted to USACE Wilmington office for review prior to construction, including clearing activities, at this site (Section C, Impact Site #4 & #5).

4. Vegetation used to stabilize banks shall be limited to native woody species, and should include establishment of a 50 foot wide vegetated buffer on the relocated channel. Stream banks will be planted with native vegetation that represents both woody (trees and shrubs) and herbaceous species. Species selection will be based on a survey of the vegetation from the approved reference reach. Survival of woody species planted at the stream mitigation sites should be at least 320 trees/acre through year three. A ten percent mortality rate will be accepted in year four (288 trees/acre) and another ten percent in year five resulting in a required survival rate of 260 trees/acre through year five.

O.N.E, Roadside Environmental Unit

5. The NCDOT shall monitor the stream relocation mitigation site for a period of five years starting the year following construction. Monitoring data at the site should include the following: reference photos, plant survival and channel stability. Data shall be collected each year for 5 years at the same time of year. No less than two (2) bankfull flow events must be documented through the required 5-year monitoring period. If less than 2 bankfull events occur during the first 5 years, monitoring will continue until the second bankfull event is documented. The bankfull events must occur during separate monitoring years.

O.N.E, Roadside Environmental Unit, cont.

6. If within any monitoring year, bank or stream stability is not acceptable as determined by the Corps of Engineers, and remedial action required by the Corps of Engineers is performed, the five-year monitoring period of the affected portions of the stream will start again at monitor year one. The NCDOT will coordinate all stream mitigation remedial activities with the Corps of Engineers, Wilmington District, prior to taking any remedial action. The NCDOT will submit a brief written report with representative photographs within 90 days after the monitoring year is completed.

7. The NCDOT shall provide the Corps of Engineers, Wilmington District with a stream mitigation construction sequencing schedule within 30 days following the project preconstruction meeting. The plan, shall at a minimum, indicate a date of start of construction at the relocation site, grading schedule, planting schedule, completion of construction, monitoring schedule, and a date of potential diversion into the new channel.

8. The NCDOT and/or current and subsequent property owners shall maintain the mitigation site in its natural condition, as altered by work in the mitigation plan, in perpetuity. Prohibited activities within the mitigation site specifically include, but are not limited to: the construction or placement of roads, walkways, buildings, signs, or structures of any kind (i.e., billboards, interior fences, etc.); filling, grading, excavation, leveling, or any other earth moving activity or activity that may alter the drainage patterns on the property; the cutting, mowing, destruction, removal, or other damage of any vegetation; disposal or storage of any debris, trash, garbage, or other waste material; except as may be authorized by the mitigation plan, or subsequent modifications that are approved by the Corps of Engineers, Wilmington District. In addition, the NCDOT shall take no action, whether on or off the mitigation property, which will adversely impact the wetlands or streams on the mitigation property, except as specifically authorized by this permit, or subsequent modifications that are approved by the Corps of Engineers, Wilmington District.

9. USACE 404 condition: The NCDOT shall mitigate for 6924 linear feet of unavoidable impacts to important stream channel associated with this project by restoring 10,751 linear feet of stream channel in the Yadkin River Basin. 6,183 linear feet of perennial stream shall be restored at the Key Branch Mitigation Site in the Yadkin River Basin (Cataloging Unit 03040104). The stream restoration shall be constructed in accordance with the final mitigation plans that will be submitted and approved by the Corps of Engineers, Wilmington District prior to construction. The final plans should be based on the 60% design plans submitted to the Corps District on 6 September 2002. 4,568 linear feet of perennial stream shall be restored at the Haithcock Road Mitigation site in the Yadkin River Basin (Cataloging Unit 03040104). The stream restoration shall be constructed in accordance with the final mitigation plans that will be submitted and approved by the Corps of Engineers, Wilmington District prior to construction.

b. DWQ 401 condition: Compensatory mitigation for impacts to streams shall be done for 7249 linear feet of stream impact in the Yadkin Basin and 351 linear feet of impact in the Lumber Basin, at a replacement ratio of 1:1. A final plan for the Haithcock Mitigation Site shall be submitted, and written approval received from the NC Division of Water Quality, by October 1, 2003. A final plan for the Key Branch Mitigation Site shall be submitted, and written approval received from the NC Division of Water Quality, by October 1, 2003.

10. The NCDOT shall mitigate for 351 linear feet of unavoidable impacts to important stream channel associated with this project by restoring 702 linear feet of stream channel in the Lumber River Basin (Cataloging Unit 03040203). The stream restoration shall be constructed at the Myrick's Pond Mitigation Site as identified in the Myrick's Pond Mitigation Plan, dated October 2002. The stream restoration shall be constructed in accordance with the final mitigation plans that will be submitted and approved by the Corps of Engineers, Wilmington District prior to construction.

O.N.E, Roadside Environmental Unit, cont.

11. The proposed stream restoration design shall be based on an approved stable reference reach. Baseline data on the reference reach channel dimension, pattern, and profile shall be collected and used as a blueprint for the channel restoration design. A detailed final design plan of the stream restoration shall be submitted to the Corps of Engineers, Wilmington District for review and approval prior to construction.

12. The development of a monitoring plan for the design reach that would assesses geomorphologic and biological parameters will be required and shall be in keeping with "Stream Mitigation Guidelines", dated April 2003. The monitoring plan should include the protocol and provisions for providing reference photographs, channel stability analysis and biological data on a yearly basis. Reference photographs, both longitudinal and lateral, should be taken at least twice a year, preferably in winter and summer and at permanently established locations. Perpendicular transects or cross sections should be permanently established at selected points on the designed reach where channel width, depth, cross-sectional area, and lateral photographs will be collected and provided in the annual monitoring reports. Cross sections shall be established once every 20 bank-full widths and will be divided evenly between riffle and pool bed features. Additional cross sections should be considered for areas where there are structures or other areas where there is a chance of failure.

13. An as-built plan will be required for the design reach. The as-built should also include longitudinal profile (three longitudinal profiles, each covering 20 bankfull-widths) data for the design reach, that should be monitored and data recorded annually. Design reach channel geometry measurements should also be a part of the as-built information. They will include sinuosity, meander wavelength, belt width, meander width ratio and radius of curvature. This plan should also show the location of all proposed attendant features, e.g. in-stream, bank protection or grade control structures, and the location of all sampling plots, transects, photography reference points, etc.

14. USACE 404 requirement: The NCDOT shall mitigate for 2.1 acres of unavoidable impacts to riverine wetlands within the Lumber River Basin (Hydrologic Catalog Unit 03040203) by providing 2.5 acres of riverine wetland restoration at the Myrick's Pond Site as identified in the Myrick's Pond Mitigation Plan, dated October 2002. DWQ 401 requirement: Compensatory mitigation of 55.38 acres shall be done for 27.69 acres of impacts to jurisdictional wetlands in the Yadkin River Basin. In addition, 2.45 acres of compensatory mitigation shall be provided to offset 2.12 acres of jurisdictional wetlands in the Lumber River Basin.

a. The NCDOT shall identify a reference site that is adjacent to or near the proposed restoration site and will not be impacted by the proposed highway construction. The applicant will coordinate a field meeting with the Corps of Engineers to approve the reference site selection prior to final mitigation design and restoration of the mitigation site. Baseline data on the reference site hydrology, surface elevations, and vegetation shall be collected and used as a blueprint for the wetland restoration design. A detailed design plan of the wetland restoration shall be submitted to this office for review prior to construction, including clearing activities, at this site.

b. To meet the success criteria, the monitoring data must show that for each normal precipitation year within the monitoring period, the site exhibits saturation within the upper 12 inches of the soil surface for a minimum of 12.5% or 28 days, or greater consecutive day duration during the growing season and inundation must occur 5 out of 10 years or 50% of the years monitored, at a minimum frequency. Baseline hydrologic data shall be obtained from the reference site, which can be used to support the mitigation site's hydrology success. WETS tables for Richmond County will be utilized as appropriate to determine normal precipitation years.

O.N.E, Roadside Environmental Unit, cont.

c.If there are no normal precipitation years during the first five years of monitoring, to meet performance criteria, the NCDOT will continue to monitor hydrology on the site until it shows that the site has been inundated or saturated as described above during a normal precipitation year.

d.The mitigation site shall be suitably graded to promote the establishment of planted wetland vegetation. If mineral soil is exposed at the desired restoration grade, the site should be graded to at least minus one-foot and brought back to grade by providing at least one foot of wetland topsoil. If organic soil is exposed at the desired restoration grade, the soil should be disked or suitability prepared for planting. Every effort must be made to utilize the topsoil from the impacted wetlands on this project to promote wetland re-vegetation.

e.Vegetation monitoring must begin in the spring just after leaf-out. Permanent randomly located sample plots shall be established at the mitigation site. Plot size should be based on established standards for sampling vegetation planted at the target densities, usually 0.05 acre (50-foot X 50-foot). A minimum of three vegetation sampling plots shall be established at the site. After the first year of monitoring, the sample size (number of plots) shall be checked by use of statistical methods used to identify adequate sample size and if necessary adjusted. The planted tree stock shall be marked by use of tree marking paint and/or tree tags for identification and sampling. Plants that have colonized the sample plot should be identified and noted in the monitoring report but not used in the planted vegetation monitoring calculations. Plant recruitment should be calculated as a separate item and corrective measures may need to be taken if the volunteers are undesirable or are jeopardizing the survival of the planted stock. The measurement of planted stock survival using stem density will be acceptable provided that only planted stock is counted. In addition, in order to get an indication of health and vigor of the planted stock, general observations of lateral plant growth, leaf and bud development should also be annotated in the reports.

f.Continually recording monitoring wells, surface gauges and/or piezometers shall be developed in the reference site and restoration site and be of sufficient numbers and adequately spaced to measure the extent, frequency and duration of the site inundation/saturation. This will aid in quickly identifying problem areas for remediation and determine the hydrologic success of the mitigation effort. The NCDOT must comply with USACE WRP Technical Note HY-IA3.1 for installation and development of the monitor wells and/or piezometers. Monitor wells shall be visited frequently to avoid lengthy down time of non-functioning wells and maintenance shall be scheduled in such a way as to minimize any down time for repairs or replacement. Lengthy down time of wells during the growing season may result in the extension of the monitoring period in order to fill in gaps in the data.

g.The NCDOT and/or current and subsequent property owners shall maintain the mitigation site in its natural condition, as altered by work in the mitigation plan, in perpetuity. Prohibited activities within the mitigation site specifically include, but are not limited to: the construction or placement of roads, walkways, buildings, signs, or structures of any kind (i.e., billboards, interior fences, etc.); filling, grading, excavation, leveling, or any other earth moving activity or activity that may alter the drainage patterns on the property; the cutting, mowing, destruction, removal, or other damage of any vegetation; disposal or storage of any debris, trash, garbage, or other waste material; except as may be authorized by the mitigation plan, or subsequent modifications that are approved by the Corps of Engineers, Wilmington District. In addition, the NCDOT shall take no action, whether on or off the mitigation property, which will adversely impact the wetlands or streams on the mitigation property, except as specifically authorized by this permit, or subsequent modifications that are approved by the Corps of Engineers, Wilmington District.

O.N.E, Roadside Environmental Unit, cont.

15. The NCDOT shall mitigate for 21 acres of unavoidable impacts to riverine wetlands and 6.7 acres of non-riverine wetlands within the Yadkin River Basin (Hydrologic Catalog Units 03040104 & 03040201) by restoring, at a minimum, 55.4 acres of riverine wetlands at the Key Branch Mitigation Site as described in the report entitled "Key Branch Wetland Mitigation Plan" dated August 24, 2001.

16. Except as described in the mitigation plan, no activities shall be initiated, conducted or allowed on the Key Branch Mitigation Site that may disturb, impair, alter, and/or modify the hydrology, vegetation and/or hydric soils of any of the existing wetland areas, including any restored wetlands.

17. The NCDOT and/or current and subsequent property owners shall maintain the Key Branch Mitigation Site, Myrick's Pond Mitigation Site, Haithcock Road Stream Mitigation Site and the on-site mitigation sites in their natural conditions, as altered by work in the mitigation plans, in perpetuity. Prohibited activities within the mitigation sites specifically include, but are not limited to: the construction or placement of roads, walkways, pathways, buildings, signs, or structures of any kind (i.e., billboards, interior fences, etc.); filling, grading, excavating, leveling, or any other earth moving activity that may alter the drainage patterns on the property; the cutting, mowing, destruction, removal, or other damage of any vegetation; disposal or storage of any debris, trash, garbage, or other waste material; except as may be approved by the Corps of Engineers. In addition, the NCDOT and/or current and subsequent property owners shall take no action, whether on or off the mitigation properties, which will adversely impact the wetlands or streams on the mitigation sites, except as specifically authorized by this permit, or subsequent modifications that are approved by the Corps of Engineers, Wilmington District.

18. The applicant shall protect all compensatory mitigation sites from future alterations by placing conservation covenants and restrictions running with the land and recorded with the deed, conveyance, or transfer. The Corps shall approve the language of conservation covenants and restrictions, prior to recordation. The applicant shall record the conservation covenants and restrictions within 4 months after obtaining the land interest. The conservation covenants and restrictions shall be recorded in the land records of their respective counties prior to the start of the mitigation construction of the mitigation sites. The applicant shall submit a copy of the fully executed and recorded deed, with the liber and folio number stamped, thereon, and property plat to the Corps within 30 days following recordation. Upon any offers for purchase, transfer, or grant of the mitigation sites, the purchaser, offerer, or grantee must receive notification that the covenants and restrictions are included in the deed. These covenants and restrictions should include prohibitions against any discharges of dredged or fill material, permanent flooding, discharges of untreated stormwater, excavation, tree cutting, removal of vegetation, or construction within the area of easement, as displayed on the plat map which describes the property being conveyed, granted, or transferred, except as authorized by the Corps. The Corps shall approve any alteration of the language or restrictions in the covenants and restrictions.

19. When final design plans are completed for TIP R-2231 and R3303, any necessary permit modification requests shall be submitted to the Corps of Engineers and the North Carolina Division of Water Quality (NCDWQ). If necessary, a public notice describing the modifications and any additional impacts associated with the modifications will be circulated for public review and comment. Final design plans shall reflect all appropriate avoidance and minimization measures taken to lessen the project impacts on aquatic resources. The NCDOT shall submit a compensatory mitigation plan for proposed additional impacts within streams and wetlands associated with the proposed modifications. Construction within streams and wetlands on TIP R-2231 and R-3303 shall begin only after approval by the Corps of Engineers of the modified impacts.

O.N.E, Division 8 Construction

20. Prior to commencing construction within jurisdictional waters of the United States for any portion of the proposed highway project, the NCDOT shall forward the latest version of project construction drawings to the Corps of Engineers, Wilmington Regulatory Field Office NCDOT Regulatory Project Manager. Half-size drawings will be acceptable.

21. The NCDOT shall schedule a meeting between its representatives, the contractor's representatives, and the Corps of Engineers, Wilmington Regulatory Field Office NCDOT Regulatory Project Manager, prior to any work within jurisdictional waters and wetlands to ensure that there is a mutual understanding of all of the terms and conditions contained within this Department of the Army Permit. The NCDOT shall notify the Corps of Engineers Project Manager a minimum of thirty (30) days in advance of the scheduled meetings in order to provide that individual with ample opportunity to schedule and participate in the required meetings.

22. The NCDOT and its contractors and/or agents shall not excavate, fill, or perform mechanized landclearing at any time in the construction or maintenance of this project within waters and/or wetlands, or cause the degradation of waters and/or wetlands, except as authorized by this permit, or any modification to this permit. There shall be no excavation from, waste disposal into, or degradation of, jurisdictional wetlands or waters associated with this permit without appropriate modification of this permit, including appropriate compensatory mitigation. This prohibition applies to all borrow and fill activities connected with this project.

23. To ensure that all borrow and waste activities occur on high ground and do not result in the degradation of adjacent wetlands and streams, except as authorized by this permit, the NCDOT shall require its contractors and/or agents to identify all areas to be used to borrow material, or to dispose of dredged, fill, or waste material. The NCDOT shall ensure that all such areas comply with the preceding condition of this permit, and shall require and maintain documentation of the location and characteristics of all borrow and disposal sites associated with this project. This information will include data regarding soils, vegetation and hydrology sufficient to clearly demonstrate compliance with the preceding condition. All information will be available to the Corps of Engineers upon request. NCDOT shall require its contractors to complete and execute reclamation plans for each waste and borrow site and provide written documentation that the reclamation plans have been implemented and all work is completed. This documentation will be provided to the Corps of Engineers within 30 days of the completion of the reclamation work.

Hydraulics Unit, Division 8 Construction

24. The NCDOT shall place the inverts of culverts and other structures greater than 48 inches in diameter in waters, streams, and wetlands one foot below the bed of the stream to allow low flow passage of water and aquatic life, unless providing passage would be impractical and the Corps of Engineers has waived this requirement. For culverts 48 inches in diameter or smaller, culverts must be buried below the bed of the stream to a depth equal to or greater than 20 percent of the diameter of the culvert. Design and placement of culverts and other structures including temporary erosion control measures shall not be conducted in a manner that may result in disequilibrium of wetlands or streambeds or banks, adjacent to, upstream or downstream of the structures.

Roadside Environmental Unit, Division 8 Construction

25. The NCDOT shall use appropriate sediment and erosion control practices which equal or exceed those outlined in the most recent version of the "North Carolina Sediment and Erosion Control Planning and Design Manual" to assure compliance with the appropriate turbidity water quality standard (50 NTU's in all streams and rivers, and 25 NTU's in all lakes).

26. The NCDOT shall remove all sediment and erosion control measures placed in wetlands or waters, and shall restore natural grades in those areas, prior to project completion.

27. The NCDOT shall take measures to prevent live or fresh concrete from coming into contact with any surface waters until the concrete has hardened.

Division 8 Construction

28. If the NCDOT discovers any previously unknown historic or archeological remains while accomplishing the authorized work, he shall immediately stop work and notify the Wilmington District Engineer who will initiate the required State/Federal coordination.

29. No excavated or fill material shall be placed at any time in waters or wetlands outside the authorized permit area, nor will it be placed in any location or in any manner so as to impair surface water flow into or out of any wetland area.

30. Upon completion of the project, the NCDOT shall complete and return the enclosed "Certification of Completion Form" to notify DWQ when all work included in the 401 Certification has been completed. The responsible party shall complete the attached form and return it to the 401/Wetlands Unit of the Division of Water Quality upon completion of the project.



REPLY TO
ATTENTION OF:

DEPARTMENT OF THE ARMY
WILMINGTON DISTRICT, CORPS OF ENGINEERS
P.O. BOX 1890
WILMINGTON, NORTH CAROLINA 28402-1890

4HM

July 11, 2003

Regulatory Division

Action ID. 199400590; TIP NO. R-2231 & R-3303

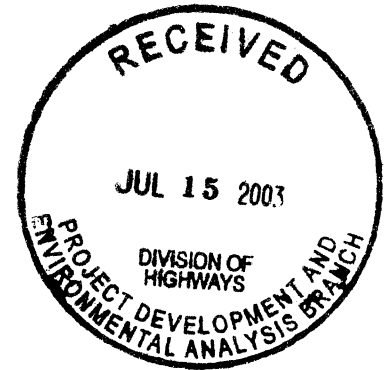

Dr. Gregory J. Thorpe, PhD, Manager
Project Development and Environmental Analysis Branch
North Carolina Department of Transportation
Division of Highways
1548 Mail Service Center
Raleigh, North Carolina 27699-1548

Dear Dr. Thorpe:

In accordance with the written request of February 14, 2003, and the ensuing administrative record, enclosed is a permit to directly discharge dredged and/or fill material into Job's Creek, and tributaries to South Prong Creek, Bell's Creek, Rocky Ford Branch, Rocky Ford Creek, Naked Creek, Big Mountain Creek and Little Mountain Creek impacting a total of 7600 linear feet of streams and 29.8 acres of wetlands to facilitate the construction of the U.S. 220, Transportation Improvements Project (TIP) R-2231, State Project Number 8.T550803, in Montgomery and Richmond Counties, North Carolina and NC 73 Extension, TIP R-3303, State Project Number 8.1581201, in Richmond County, North Carolina. The proposed four-lane, full control of access highway extends from the existing U.S. 220 four-lane facility beginning at the intersection of the existing four-lane roadway south of Ellerbe at SR 1448, in Richmond County, to the intersection of existing US 220 and US 220A, just south of Candor in Montgomery County, including the NC 73, 2-lane 24-foot extension from the intersection of US 220 and NC 73 and connecting with the new US 220 four-lane facility north of SR 1452 in Richmond County, North Carolina. This authorization also includes the discharge of dredged and/or fill material that may be required for the construction of the compensatory mitigation sites at Key Branch, Myrick's Pond, and Haithcock Road.

If any change in the authorized work is required because of unforeseen or altered conditions or for any other reason, the plans revised to show the change must be sent promptly to this office. Such action is necessary, as revised plans must be reviewed and the permit modified.

Carefully read your permit. The general and special conditions are important. Your failure to comply with these conditions could result in a violation of Federal law. Certain significant general conditions require that:

- a. You must complete construction before December 31, 2006.
- b. You must notify this office in advance as to when you intend to commence and complete work.
- c. You must allow representatives from this office to make periodic visits to your worksite as deemed necessary to assure compliance with permit plans and conditions.

Should you have questions, contact Mr. Richard K. Spencer of my Wilmington Field Office regulatory staff at telephone (910) 251-4172.

Sincerely,

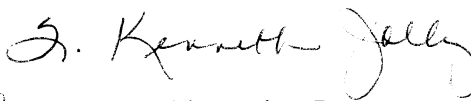
for Charles R. Alexander, Jr.
Colonel, U.S. Army
District Engineer

Enclosures

Copy Furnished with enclosures:

Chief, Source Data Unit
NOAA/National Ocean Service
ATTN: Sharon Tear N/CS261
1315 East-West Hwy., Rm 7316
Silver Spring, MD 20910-3282

Copies Furnished with special conditions and plans:

Mr. Garland Pardue, Field Supervisor
U.S. Fish and Wildlife Service
Fish and Wildlife Enhancement
Post Office Box 33726
Raleigh, North Carolina 27636-3726

Mr. Ron Sechler
National Marine Fisheries
Service, NOAA
101 Pivers Island
Beaufort, North Carolina 28516

Mr. David Rackley
National Marine Fisheries
Service, NOAA
219 Fort Johnson Road
Charleston, South Carolina 29412-9110

Mr. Ronald Mikulak, Chief
Wetlands Section - Region IV
Water Management Division
U.S. Environmental Protection Agency
Atlanta Federal Center
61 Forsyth Street, SW
Atlanta, Georgia 30303

Mr. Doug Huggett
Division of Coastal Management
North Carolina Department of
Environment and Natural Resources
1638 Mail Service Center
Raleigh, North Carolina 27699-1638

Mr. Ronald E. Ferrell, Program Manager
Wetlands Restoration Program
Division of Water Quality
1619 Mail Service Center
Raleigh, North, Carolina 27699-1619

DEPARTMENT OF THE ARMY PERMIT

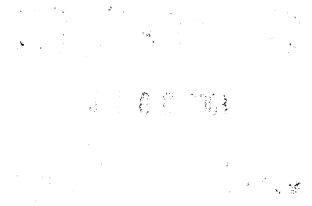

Permittee NC Department of Transportation

Permit No. 199400590

Issuing Office USAED, Wilmington

NOTE: The term "you" and its derivatives, as used in this permit, means the permittee or any future transferee. The term "this office" refers to the appropriate district or division office of the Corps of Engineers having jurisdiction over the permitted activity or the appropriate official of that office acting under the authority of the commanding officer.

You are authorized to perform work in accordance with the terms and conditions specified below.

Project Description:

Directly discharge dredged and/or fill material into Job's Creek, and tributaries to South Prong Creek, Bell's Creek, Rocky Ford Branch, Rocky Ford Creek, Naked Creek, Big Mountain Creek and Little Mountain Creek impacting a total of 7600 linear feet of streams and 29.8 acres of wetlands to facilitate the construction of the U.S. 220, Transportation Improvements Project (TIP) R-2231, State Project Number 8.T550803 and NC 73 Extension, TIP R-3303, State Project Number 8.1581201 and the discharge of dredged and/or fill material that may be required for the construction of the compensatory mitigation sites at Key Branch (Anson County), Myrick's Pond (Richmond County), and Haithcock Road (Montgomery County).

Project Location:

In the Lumber and Yadkin River basins, from the intersection of the existing four-lane roadway south of Ellerbe at SR 1448, in Richmond County, to the intersection of existing US 220 and US 220A, just south of Candor in Montgomery County, including the NC 73, 2-lane 24-foot extension from the intersection of US 220 and NC 73 and connecting with the new US 220 four-lane facility north of SR 1452 in Richmond County, North Carolina.

Permit Conditions:

General Conditions:

1. The time limit for completing the work authorized ends on December 31, 2006. If you find that you need more time to complete the authorized activity, submit your request for a time extension to this office for consideration at least one month before the above date is reached.
2. You must maintain the activity authorized by this permit in good condition and in conformance with the terms and conditions of this permit. You are not relieved of this requirement if you abandon the permitted activity, although you may make a good faith transfer to a third party in compliance with General Condition 4 below. Should you wish to cease to maintain the authorized activity or should you desire to abandon it without a good faith transfer, you must obtain a modification of this permit from this office, which may require restoration of the area.
3. If you discover any previously unknown historic or archeological remains while accomplishing the activity authorized by this permit, you must immediately notify this office of what you have found. We will initiate the Federal and state coordination required to determine if the remains warrant a recovery effort or if the site is eligible for listing in the National Register of Historic Places.

4. If you sell the property associated with this permit, you must obtain the signature of the new owner in the space provided and forward a copy of the permit to this office to validate the transfer of this authorization.

5. If a conditioned water quality certification has been issued for your project, you must comply with the conditions specified in the certification as special conditions to this permit. For your convenience, a copy of the certification is attached if it contains such conditions.

6. You must allow representatives from this office to inspect the authorized activity at any time deemed necessary to ensure that it is being or has been accomplished in accordance with the terms and conditions of your permit.

Special Conditions:

See enclosed sheet.

Further Information:
1. Congressional Authorities: You have been authorized to undertake the activity described above pursuant to:

() Section 10 of the Rivers and Harbors Act of 1899 (33 U.S.C. 403).

(X) Section 404 of the Clean Water Act (33 U.S.C. 1344).

() Section 103 of the Marine Protection, Research and Sanctuaries Act of 1972 (33 U.S.C. 1413).

2. Limits of this authorization.

a. This permit does not obviate the need to obtain other Federal, state, or local authorizations required by law.

b. This permit does not grant any property rights or exclusive privileges.

c. This permit does not authorize any injury to the property or rights of others.

d. This permit does not authorize interference with any existing or proposed Federal project.

3. Limits of Federal Liability. In issuing this permit, the Federal Government does not assume any liability for the following:

a. Damages to the permitted project or uses thereof as a result of other permitted or unpermitted activities or from natural causes.

b. Damages to the permitted project or uses thereof as a result of current or future activities undertaken by or on behalf of the United States in the public interest.

c. Damages to persons, property, or to other permitted or unpermitted activities or structures caused by the activity authorized by this permit.

d. Design or construction deficiencies associated with the permitted work.

SPECIAL CONDITIONS (Action ID. 1994-0-0590; NCDOT/TIP R-2231 & 3303)

1. All work authorized by this permit must be prepared in strict compliance with the attached plans, which are a part of this permit.

2. The permittee shall mitigate for 29.8 acres of unavoidable impacts to riverine wetlands and for 7600 linear feet of impact to important streams, associated with the project, as follows:

a. The permittee shall mitigate for 423 linear feet of unavoidable impacts to an unnamed tributary to Big Mountain Creek (Section CB, Impact Site #3), an important stream channel, by completing 423 linear feet of onsite stream relocation, as described in the permit application. The stream relocation shall be constructed in accordance with the North Carolina Wildlife Resources Commission's (NCWRC) "Stream Relocation Guidelines", and with the attached permit drawings. NCDOT shall consult with NCWRC on all stream relocations and implement all practicable recommendations in the design of specific site requirements for re-establishment of bank vegetation, and placement of meanders and habitat structures. Vegetation shall be used to the maximum extent practicable to stabilize banks, and riprap and other man-made structural measures shall be minimized.

b. The permittee shall mitigate for 253 linear feet of unavoidable impacts to an unnamed tributary to Big Mountain Creek (Section CB, Impact Site #6), an important stream channel, by completing 253 linear feet of onsite stream relocation, as described in the permit application. The stream relocation shall be constructed in accordance with the North Carolina Wildlife Resources Commission's (NCWRC) "Stream Relocation Guidelines", and with the attached permit drawings. NCDOT shall consult with NCWRC on all stream relocations and implement all practicable recommendations in the design of specific site requirements for re-establishment of bank vegetation, and placement of meanders and habitat structures. Vegetation shall be used to the maximum extent practicable to stabilize banks, and riprap and other man-made structural measures shall be minimized.

c. In addition to the stipulation in items a. and b. above, the following stipulation shall also apply to these mitigation sites:

i. The permittee shall construct all channel relocations in a dry work area. The permittee shall stabilize the relocated channel before stream flows are directed into the new channel. Whenever possible, channel relocations shall be allowed to stabilize for an entire growing season. Upon completion of the project, an as-built channel survey shall be conducted. It is recommended that stream surveys, for both project construction and project monitoring, follow the methodology contained in the USDA Forest Service Manual, *Stream Channel Reference Sites* (Harrelson, et.al, 1994). The survey should document the dimension, pattern and profile of the relocated channel.

ii. The permittee shall identify a stable reference reach that is close to the proposed relocation site and will not be impacted by the proposed highway construction. The applicant will coordinate a field meeting with the Corps of Engineers to approve the reference reach selection prior to channel design and relocation of the existing stream. Baseline data on the reference reach channel dimension, pattern, and profile shall be collected and used as a blueprint for the relocation channel design. A detailed design plan of the relocation stream shall be submitted to this office for review prior to construction, including clearing activities, at this site (Section C, Impact Site #4).

iii. Vegetation used to stabilize banks shall be limited to native woody species, and should include establishment of a 50 foot wide vegetated buffer on the relocated channel. Stream banks will be planted with native vegetation that represents both woody (trees and shrubs) and herbaceous species. Species selection will be based on a survey of the vegetation from the approved reference reach. Survival of woody species planted at the stream mitigation sites should be at least 320 trees/acre through year three. A ten percent mortality rate will be accepted in year four (288 trees/acre) and another ten percent in year five resulting in a required survival rate of 260 trees/acre through year five.

iv. The permittee shall monitor the stream relocation mitigation site for a period of five years starting the year following construction. Monitoring data at the site should include the following: reference photos, plant survival and channel stability. Data shall be collected each year for 5 years at the same time of year. No less than two (2) bankfull flow events must be documented through the required 5-year monitoring period. If less than 2 bankfull events occur during the first 5 years, monitoring will continue until the second bankfull event is documented. The bankfull events must occur during separate monitoring years.

v. If within any monitoring year, bank or stream stability is not acceptable as determined by the Corps of Engineers, and remedial action required by the Corps of Engineers is performed, the five-year monitoring period of the affected portions of the stream will start again at monitor year one. The permittee will coordinate all stream mitigation remedial activities with the Corps of Engineers, Wilmington District, prior to taking any remedial action. The permittee will submit a brief written report with representative photographs within 90 days after the monitoring year is completed.

vi. The permittee shall provide the Corps of Engineers, Wilmington District with a stream mitigation construction sequencing schedule within 30 days following the project preconstruction meeting. The plan, shall at a minimum, indicate a date of start of construction at the relocation site, grading schedule, planting schedule, completion of construction, monitoring schedule, and a date of potential diversion into the new channel.

vii. The permittee and/or current and subsequent property owners shall maintain the mitigation site in its natural condition, as altered by work in the mitigation plan, in perpetuity. Prohibited activities within the mitigation site specifically include, but are not limited to: the construction or placement of roads, walkways, buildings, signs, or structures of any kind (i.e., billboards, interior fences, etc.); filling, grading, excavation, leveling, or any other earth

moving activity or activity that may alter the drainage patterns on the property; the cutting, mowing, destruction, removal, or other damage of any vegetation; disposal or storage of any debris, trash, garbage, or other waste material; except as may be authorized by the mitigation plan, or subsequent modifications that are approved by the Corps of Engineers, Wilmington District. In addition, the permittee shall take no action, whether on or off the mitigation property, which will adversely impact the wetlands or streams on the mitigation property, except as specifically authorized by this permit, or subsequent modifications that are approved by the Corps of Engineers, Wilmington District.

d. The permittee shall mitigate for 6924 linear feet of unavoidable impacts to important stream channel associated with this project by restoring 10,751 linear feet of stream channel in the Yadkin River Basin. 6,183 linear feet of perennial stream shall be restored at the Key Branch Mitigation Site in the Yadkin River Basin (Cataloging Unit 03040104). The stream restoration shall be constructed in accordance with the final mitigation plans that will be submitted and approved by the Corps of Engineers, Wilmington District prior to construction. The final plans should be based on the 60% design plans submitted to the Corps District on 6 September 2002. 4,568 linear feet of perennial stream shall be restored at the Haithcock Road Mitigation site in the Yadkin River Basin (Cataloging Unit 03040104). The stream restoration shall be constructed in accordance with the final mitigation plans that will be submitted and approved by the Corps of Engineers, Wilmington District prior to construction.

e. The permittee shall mitigate for 351 linear feet of unavoidable impacts to important stream channel associated with this project by restoring 702 linear feet of stream channel in the Lumber River Basin (Cataloging Unit 03040203). The stream restoration shall be constructed at the Myrick's Pond Mitigation Site as identified in the Myrick's Pond Mitigation Plan, dated October 2002. The stream restoration shall be constructed in accordance with the final mitigation plans that will be submitted and approved by the Corps of Engineers, Wilmington District prior to construction.

f. In addition to the stipulation in items d. and e. above, the following stipulation shall also apply to these mitigation sites:

i. The proposed stream restoration design shall be based on an approved stable reference reach. Baseline data on the reference reach channel dimension, pattern, and profile shall be collected and used as a blueprint for the channel restoration design. A detailed final design plan of the stream restoration shall be submitted to the Corps of Engineers, Wilmington District for review and approval prior to construction.

ii. The development of a monitoring plan for the design reach that would assesses geomorphologic and biological parameters will be required and shall be in keeping with "Stream Mitigation Guidelines", dated April 2003. The monitoring plan should include the protocol and provisions for providing reference photographs, channel stability analysis and biological data on a yearly basis. Reference photographs, both longitudinal and lateral, should be taken at least twice a year, preferably in winter and summer and at permanently established locations. Perpendicular transects or cross sections should be permanently established at

selected points on the designed reach where channel width, depth, cross-sectional area, and lateral photographs will be collected and provided in the annual monitoring reports. Cross sections shall be established once every 20 bank-full widths and will be divided evenly between riffle and pool bed features. Additional cross sections should be considered for areas where there are structures or other areas where there is a chance of failure.

iii. An as-built plan will be required for the design reach. The as-built should also include longitudinal profile (three longitudinal profiles, each covering 20 bankfull-widths) data for the design reach, that should be monitored and data recorded annually. Design reach channel geometry measurements should also be a part of the as-built information. They will include sinuosity, meander wavelength, belt width, meander width ratio and radius of curvature. This plan should also show the location of all proposed attendant features, e.g. in-stream, bank protection or grade control structures, and the location of all sampling plots, transects, photography reference points, etc.

g. The permittee shall mitigate for 2.1 acres of unavoidable impacts to riverine wetlands within the Lumber River Basin (Hydrologic Catalog Unit 03040203) by providing 2.5 acres of riverine wetland restoration at the Myrick's Pond Site as identified in the Myrick's Pond Mitigation Plan, dated October 2002. In addition, the following stipulations shall apply to this mitigation site:

i. The permittee shall identify a reference site that is adjacent to or near the proposed restoration site and will not be impacted by the proposed highway construction. The applicant will coordinate a field meeting with the Corps of Engineers to approve the reference site selection prior to final mitigation design and restoration of the mitigation site. Baseline data on the reference site hydrology, surface elevations, and vegetation shall be collected and used as a blueprint for the wetland restoration design. A detailed design plan of the wetland restoration shall be submitted to this office for review prior to construction, including clearing activities, at this site.

ii. To meet the success criteria, the monitoring data must show that for each normal precipitation year within the monitoring period, the site exhibits saturation within the upper 12 inches of the soil surface for a minimum of 12.5% or 28 days, or greater consecutive day duration during the growing season and inundation must occur 5 out of 10 years or 50% of the years monitored, at a minimum frequency. Baseline hydrologic data shall be obtained from the reference site, which can be used to support the mitigation site's hydrology success. WETS tables for Richmond County will be utilized as appropriate to determine normal precipitation years.

iii. If there are no normal precipitation years during the first five years of monitoring, to meet performance criteria, the permittee will continue to monitor hydrology on the site until it shows that the site has been inundated or saturated as described above during a normal precipitation year.

iv. The mitigation site shall be suitably graded to promote the establishment of planted wetland vegetation. If mineral soil is exposed at the desired restoration grade, the site should be graded to at least minus one-foot and brought back to grade by providing at least one foot of wetland topsoil. If organic soil is exposed at the desired restoration grade, the soil should be disked or suitability prepared for planting. Every effort must be made to utilize the topsoil from the impacted wetlands on this project to promote wetland re-vegetation.

v. The mitigation site will be planted with native vegetation that represents both woody (trees and shrubs) and herbaceous species. Species selection will be based on a survey of the vegetation from the approved reference site. Survival of woody species planted at the mitigation site must be at least 320 trees/acre through year three. A ten percent mortality rate will be accepted in year four (288 trees/acre) and another ten percent in year five resulting in a required survival rate of 260 trees/acre through year five.

vi. Vegetation monitoring must begin in the spring just after leaf-out. Permanent randomly located sample plots shall be established at the mitigation site. Plot size should be based on established standards for sampling vegetation planted at the target densities, usually 0.05 acre (50-foot X 50-foot). A minimum of three vegetation sampling plots shall be established at the site. After the first year of monitoring, the sample size (number of plots) shall be checked by use of statistical methods used to identify adequate sample size and if necessary adjusted. The planted tree stock shall be marked by use of tree marking paint and/or tree tags for identification and sampling. Plants that have colonized the sample plot should be identified and noted in the monitoring report but not used in the planted vegetation monitoring calculations. Plant recruitment should be calculated as a separate item and corrective measures may need to be taken if the volunteers are undesirable or are jeopardizing the survival of the planted stock. The measurement of planted stock survival using stem density will be acceptable provided that only planted stock is counted. In addition, in order to get an indication of health and vigor of the planted stock, general observations of lateral plant growth, leaf and bud development should also be annotated in the reports.

vii. Continually recording monitoring wells, surface gauges and/or piezometers shall be developed in the reference site and restoration site and be of sufficient numbers and adequately spaced to measure the extent, frequency and duration of the site inundation/saturation. This will aid in quickly identifying problem areas for remediation and determine the hydrologic success of the mitigation effort. The permittee must comply with USACE WRP Technical Note HY-IA3.1 for installation and development of the monitor wells and/or piezometers. Monitor wells shall be visited frequently to avoid lengthy down time of non-functioning wells and maintenance shall be scheduled in such a way as to minimize any down time for repairs or replacement. Lengthy down time of wells during the growing season may result in the extension of the monitoring period in order to fill in gaps in the data.

viii. The permittee and/or current and subsequent property owners shall maintain the mitigation site in its natural condition, as altered by work in the mitigation plan, in perpetuity. Prohibited activities within the mitigation site specifically include, but are not limited to: the construction or placement of roads, walkways, buildings, signs, or structures of any kind

(i.e., billboards, interior fences, etc.); filling, grading, excavation, leveling, or any other earth moving activity or activity that may alter the drainage patterns on the property; the cutting, mowing, destruction, removal, or other damage of any vegetation; disposal or storage of any debris, trash, garbage, or other waste material; except as may be authorized by the mitigation plan, or subsequent modifications that are approved by the Corps of Engineers, Wilmington District. In addition, the permittee shall take no action, whether on or off the mitigation property, which will adversely impact the wetlands or streams on the mitigation property, except as specifically authorized by this permit, or subsequent modifications that are approved by the Corps of Engineers, Wilmington District.

h. The permittee shall mitigate for 21 acres of unavoidable impacts to riverine wetlands and 6.7 acres of non-riverine wetlands within the Yadkin River Basin (Hydrologic Catalog Units 03040104 & 03040201) by restoring, at a minimum, 55.4 acres of riverine wetlands at the Key Branch Mitigation Site as described in the report entitled "Key Branch Wetland Mitigation Plan" dated August 24, 2001. In addition, the following stipulations shall apply to this mitigation site:

i. To meet the success criteria, the monitoring data must show that for each normal precipitation year within the monitoring period, the site exhibits saturation within the upper 12 inches of the soil surface for a minimum of 12.5% or 31 days, or greater consecutive day duration during the growing season and inundation must occur 5 out of 10 years or 50% of the years monitored, at a minimum frequency. Baseline hydrologic data shall be obtained from the reference site, which can be used to support the mitigation site's hydrology success. WETS tables for Moore County will be utilized as appropriate to determine normal precipitation years.

ii. The mitigation site will be planted with native vegetation that represents both woody (trees and shrubs) and herbaceous species. Species selection will be based on a survey of the vegetation from the reference sites. Survival of woody species planted at the mitigation site should be at least 320 trees/acre through year three. A ten percent mortality rate will be accepted in year four (288 trees/acre) and another ten percent in year five resulting in a required survival rate of 260 trees/acre through year five.

iii. Vegetation monitoring must begin in the spring just after leaf-out. Permanent randomly located sample plots shall be established at the mitigation site. Plot size should be based on established standards for sampling vegetation planted at the target densities, usually 0.05 acre (50-foot X 50-foot). A minimum of eight vegetation sampling plots shall be established at the site. After the first year of monitoring, the sample size (number of plots) shall be checked by use of statistical methods used to identify adequate sample size and if necessary adjusted. The planted tree stock shall be marked by use of tree marking paint and/or tree tags for identification and sampling. Plants that have colonized the sample plot should be identified and noted in the monitoring report but not used in the planted vegetation monitoring calculations. Plant recruitment should be calculated as a separate item and corrective measures may need to be taken if the volunteers are undesirable or are jeopardizing the survival of the planted stock. The measurement of planted stock survival using stem density will be acceptable provided that only planted stock is counted. In addition, in order to get an indication of health and vigor of the

planted stock, general observations of lateral plant growth, leaf and bud development should also be annotated in the reports.

iv. Continually recording monitoring wells, surface gauges and/or piezometers shall be developed in the reference sites (four wells) and restoration site (eight wells) and be adequately spaced to measure the extent, frequency and duration of the site inundation/saturation. This will aid in quickly identifying problem areas for remediation and determine the hydrologic success of the mitigation effort. The permittee must comply with USACE WRP Technical Note HY-IA3.1 for installation and development of the monitor wells and/or piezometers. Monitor wells shall be visited frequently to avoid lengthy down time of non-functioning wells and maintenance shall be scheduled in such a way as to minimize any down time for repairs or replacement. Lengthy down time of wells during the growing season may result in the extension of the monitoring period in order to fill in gaps in the data.

v. Except as described in the mitigation plan, no activities shall be initiated, conducted or allowed on the Key Branch Mitigation Site that may disturb, impair, alter, and/or modify the hydrology, vegetation and/or hydric soils of any of the existing wetland areas, including any restored wetlands.

i. The permittee and/or current and subsequent property owners shall maintain the Key Branch Mitigation Site, Myrick's Pond Mitigation Site, Haithcock Road Stream Mitigation Site and the on-site mitigation sites in their natural conditions, as altered by work in the mitigation plans, in perpetuity. Prohibited activities within the mitigation sites specifically include, but are not limited to: the construction or placement of roads, walkways, pathways, buildings, signs, or structures of any kind (i.e., billboards, interior fences, etc.); filling, grading, excavating, leveling, or any other earth moving activity that may alter the drainage patterns on the property; the cutting, mowing, destruction, removal, or other damage of any vegetation; disposal or storage of any debris, trash, garbage, or other waste material; except as may be approved by the Corps of Engineers. In addition, the permittee and/or current and subsequent property owners shall take no action, whether on or off the mitigation properties, which will adversely impact the wetlands or streams on the mitigation sites, except as specifically authorized by this permit, or subsequent modifications that are approved by the Corps of Engineers, Wilmington District.

j. The applicant shall protect all compensatory mitigation sites from future alterations by placing conservation covenants and restrictions running with the land and recorded with the deed, conveyance, or transfer. The Corps shall approve the language of conservation covenants and restrictions, prior to recordation. The applicant shall record the conservation covenants and restrictions within 4 months after obtaining the land interest. The conservation covenants and restrictions shall be recorded in the land records of their respective counties prior to the start of the mitigation construction of the mitigation sites. The applicant shall submit a copy of the fully executed and recorded deed, with the liber and folio number stamped, thereon, and property plat to the Corps within 30 days following recordation. Upon any offers for purchase, transfer, or grant of the mitigation sites, the purchaser, offerer, or grantee must receive notification that the covenants and restrictions are included in the deed. These covenants and

restrictions should include prohibitions against any discharges of dredged or fill material, permanent flooding, discharges of untreated stormwater, excavation, tree cutting, removal of vegetation, or construction within the area of easement, as displayed on the plat map which describes the property being conveyed, granted, or transferred, except as authorized by the Corps. The Corps shall approve any alteration of the language or restrictions in the covenants and restrictions.

3. When final design plans are completed for TIP R-2231 and R3303, any necessary permit modification requests shall be submitted to the Corps of Engineers and the North Carolina Division of Water Quality (NCDWQ). If necessary, a public notice describing the modifications and any additional impacts associated with the modifications will be circulated for public review and comment. Final design plans shall reflect all appropriate avoidance and minimization measures taken to lessen the project impacts on aquatic resources. The permittee shall submit a compensatory mitigation plan for proposed additional impacts within streams and wetlands associated with the proposed modifications. Construction within streams and wetlands on TIP R-2231 and R-3303 shall begin only after approval by the Corps of Engineers of the modified impacts.

4. Prior to commencing construction within jurisdictional waters of the United States for any portion of the proposed highway project, the permittee shall forward the latest version of project construction drawings to the Corps of Engineers, Wilmington Regulatory Field Office NCDOT Regulatory Project Manager. Half-size drawings will be acceptable.

5. The permittee shall schedule a meeting between its representatives, the contractor's representatives, and the Corps of Engineers, Wilmington Regulatory Field Office NCDOT Regulatory Project Manager, prior to any work within jurisdictional waters and wetlands to ensure that there is a mutual understanding of all of the terms and conditions contained within this Department of the Army Permit. The permittee shall notify the Corps of Engineers Project Manager a minimum of thirty (30) days in advance of the scheduled meetings in order to provide that individual with ample opportunity to schedule and participate in the required meetings.

6. The permittee and its contractors and/or agents shall not excavate, fill, or perform mechanized landclearing at any time in the construction or maintenance of this project within waters and/or wetlands, or cause the degradation of waters and/or wetlands, except as authorized by this permit, or any modification to this permit. There shall be no excavation from, waste disposal into, or degradation of, jurisdictional wetlands or waters associated with this permit without appropriate modification of this permit, including appropriate compensatory mitigation. This prohibition applies to all borrow and fill activities connected with this project.

7. To ensure that all borrow and waste activities occur on high ground and do not result in the degradation of adjacent wetlands and streams, except as authorized by this permit, the permittee shall require its contractors and/or agents to identify all areas to be used to borrow material, or to dispose of dredged, fill, or waste material. The permittee shall ensure that all such areas comply with the preceding condition (*) of this permit, and shall require and maintain documentation of the location and characteristics of all borrow and disposal sites associated with

this project. This information will include data regarding soils, vegetation and hydrology sufficient to clearly demonstrate compliance with the preceding condition (*). All information will be available to the Corps of Engineers upon request. NCDOT shall require its contractors to complete and execute reclamation plans for each waste and borrow site and provide written documentation that the reclamation plans have been implemented and all work is completed. This documentation will be provided to the Corps of Engineers within 30 days of the completion of the reclamation work.

8. The permittee shall comply with the conditions specified in the water quality certification, No. 3419, issued by the North Carolina Division of Water Quality on April 1, 2003.

9. The permittee shall place the inverts of culverts and other structures greater than 48 inches in diameter in waters, streams, and wetlands one foot below the bed of the stream to allow low flow passage of water and aquatic life, unless providing passage would be impractical and the Corps of Engineers has waived this requirement. For culverts 48 inches in diameter or smaller, culverts must be buried below the bed of the stream to a depth equal to or greater than 20 percent of the diameter of the culvert. Design and placement of culverts and other structures including temporary erosion control measures shall not be conducted in a manner that may result in dis-equilibrium of wetlands or streambeds or banks, adjacent to, upstream or downstream of the structures.

10. The permittee shall use appropriate sediment and erosion control practices which equal or exceed those outlined in the most recent version of the "North Carolina Sediment and Erosion Control Planning and Design Manual" to assure compliance with the appropriate turbidity water quality standard (50 NTU's in all streams and rivers, and 25 NTU's in all lakes).

11. The permittee shall remove all sediment and erosion control measures placed in wetlands or waters, and shall restore natural grades in those areas, prior to project completion.

12. The permittee shall take measures to prevent live or fresh concrete from coming into contact with any surface waters until the concrete has hardened.

13. If the permittee discovers any previously unknown historic or archeological remains while accomplishing the authorized work, he shall immediately stop work and notify the Wilmington District Engineer who will initiate the required State/Federal coordination.

14. No excavated or fill material shall be placed at any time in waters or wetlands outside the authorized permit area, nor will it be placed in any location or in any manner so as to impair surface water flow into or out of any wetland area.

15. The permittee shall maintain the authorized work in good condition and in conformance with the terms and conditions of this permit. The permittee is not relieved of this requirement if he abandons the permitted activity without transferring it to a third party.

16. All fill material shall be clean and free of any pollutants except in trace quantities. Metal products, organic materials, or unsightly debris will not be used.

17. This Department of the Army permit does not obviate the need to obtain other Federal, State, or local authorizations required by law.

18. In issuing this permit, the Federal Government does not assume any liability for:

- a. Damages to the permitted project or uses thereof as a result of other permitted or unpermitted activities or from natural causes.
- b. Damages to the permitted project or uses thereof as a result of current or future Federal activities initiated on behalf of the general public.
- c. Damages to other permitted or un-permitted activities or structures caused by the authorized activity.
- d. Design and construction deficiencies associated with the permitted work.
- e. Damage claims associated with any future modification, suspension, or revocation of this permit.

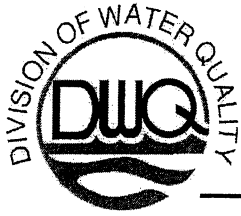

Michael F. Easley, Governor
William G. Ross Jr., Secretary
North Carolina Department of Environment and Natural Resources
Alan W. Klimek, P.E. Director
Division of Water Quality

April 1, 2003

Dr. Gregory J. Thorpe, PhD, Manager
Planning and Environmental Branch
North Carolina Department of Transportation
1548 Mail Service Center
Raleigh, North Carolina, 27699-1548

Dear Dr. Thorpe:

Re: 401 Water Quality Certification Pursuant to Section 401 of the Federal Clean Water Act,
Proposed Ellerbe Bypass and Ellerbe Connector (NC 73 Extension) in Richmond and Montgomery Counties.
WQC Project No. 000874

Attached hereto is a copy of Certification No. 3419 issued to The North Carolina Department of Transportation dated April 1, 2003.

If we can be of further assistance, do not hesitate to contact us.

Sincerely,

Alan W. Klimek, P.E.

Attachments

cc: Wilmington District Corps of Engineers
Corps of Engineers Wilmington Field Office
DWQ Fayetteville Regional Office
Central Files
File Copy



NORTH CAROLINA 401 WATER QUALITY CERTIFICATION

THIS CERTIFICATION is issued in conformity with the requirements of Section 401 Public Laws 92-500 and 95-217 of the United States and subject to the North Carolina Division of Water Quality (DWQ) Regulations in 15 NCAC 2H, Section .0500. This certification authorizes the NCDOT to place fill material in 29.81 acres of jurisdictional wetlands and 7600 linear feet of streams in Richmond and Montgomery Counties. The project shall be constructed pursuant to the application dated February 14, 2003 to construct the Ellerbe Bypass (TIP R-2231) and the Ellerbe Connector (TIP R-3303) in Richmond and Montgomery Counties and the impacts shall occur as described below.

Wetland Impacts in the Yadkin River Basin

Section	Riverine (acres)	Non-Riverine (acres)	Total (acres)
Section A	8.01	4.28	12.29
Section B	5.68	2.38	8.06
Section CA	0.00	0.00	0.00
Section CB	6.02	0.00	6.02
R-3303	1.32	0.00	1.32
Total	21.03	6.66	27.69

Wetland Impacts in the Lumber River Basin

Section	Riverine (acres)	Non-Riverine (acres)	Total (acres)
Section A	0.00	0.00	0.00
Section B	0.25	0.00	0.25
Section CA	1.87	0.00	1.87
Section CB	0.00	0.00	0.00
R-3303	0.00	0.00	0.00
Total	2.12	0.00	2.12

Surface Water Impacts for the Yadkin River Basin

Section	Stream Impacts (linear feet)	Natural Channel Design (linear feet)	Offsite Mitigation Requirement (1:1 Ratio)
Section A	2335	0	2335
Section B	1854	0	1854
Section CA	0	0	0
Section CB	2693	676	2017
R-3303	367	0	367
Total	7249	-676	6573



Surface Water Impacts for the Lumber River Basin

Section	Impacts (linear feet)	Ponds (acres)	On-Site Natural Channel Design (linear feet)	Mitigation Required
Section A	0	0		0
Section B	0	12.36	1066	-1066
Section CA	351	0		351
Section CB	0	0		0
R-3303	0	0		0
Total	351	12.36	1066	-715

The application provides adequate assurance that the discharge of fill material into the waters of Yadkin and Lumber River Basins in conjunction with the proposed development will not result in a violation of applicable Water Quality Standards and discharge guidelines. Therefore, the State of North Carolina certifies that this activity will not violate the applicable portions of Sections 301, 302, 303, 306, 307 of PL 92-500 and PL 95-217 if conducted in accordance with the application and conditions hereinafter set forth.

This approval is only valid for the purpose and design that you submitted in your application, as described in the Public Notice. Should your project change, you are required to notify the DWQ and you may be required to submit a new application. If the property is sold, the new owner must be given a copy of this Certification and approval letter, and is thereby responsible for complying with all the conditions. If any additional wetland impacts, or stream impacts, for this project (now or in the future) exceed one acre or 150 linear feet, respectively, additional compensatory mitigation may be required as described in 15A NCAC 2H .0506 (h) (6) and (7). For this approval to remain valid, you are required to comply with all the conditions listed below. In addition, you should obtain all other federal, state or local permits before proceeding with your project including (but not limited to) Sediment and Erosion control, Coastal Stormwater, Non-discharge and Water Supply watershed regulations. This Certification shall expire three years from the date of the cover letter from DWQ or on the same day as the expiration date of the corresponding Corps of Engineers Permit, whichever is sooner.

Condition(s) of Certification:

1. Appropriate sediment and erosion control practices which equal or exceed those outlined in the most recent version of the "North Carolina Sediment and Erosion Control Planning and Design Manual" or the "North Carolina Surface Mining Manual" whichever is more appropriate (available from the Division of Land Resources (DLR) in the DENR Regional or Central Offices) shall be in full compliance with all specifications governing the proper design, installation and operation and maintenance of such Best Management Practices in order to assure compliance with the appropriate turbidity water quality standard (50 NTUs in all fresh water streams and rivers not designated as trout waters; 25 NTUs in all lakes and reservoirs, and all saltwater classes; and 10 NTUs in trout waters);
2. Sediment and erosion control measures shall not be placed in wetlands or waters to the maximum extent practicable. If placement of sediment and erosion control devices in wetlands and waters is unavoidable, they shall be removed and the natural grade restored within two months of the Division of Land Resources has released the project;

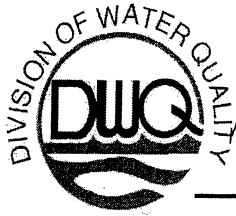

3. If an environmental document is required, this Certification is not valid until a FONSI or ROD is issued by the State Clearinghouse. All water quality-related conditions of the FONSI or ROD shall become conditions of this Certification;
4. Measures shall be taken to prevent live or fresh concrete from coming into contact with waters of the state until the concrete has hardened;
5. There shall be no excavation from or waste disposal into jurisdictional wetlands or waters associated with this permit without appropriate modification of this certification. Should waste or borrow sites be located in wetlands or stream, compensatory mitigation will be required since it is a direct impact from road construction activities.
6. All channel relocations will be constructed in a dry work area, and stabilized before stream flows are diverted. Channel relocations will be completed and stabilized prior to diverting water into the new channel. Whenever possible, channel relocations shall be allowed to stabilize for an entire growing season. Vegetation used for bank stabilization shall be limited to native woody species, and should include establishment of a 30 foot wide wooded and an adjacent 20 foot wide vegetated buffer on both sides of the relocated channel to the maximum extent practical. A transitional phase incorporating coir fiber and seedling establishment is allowable. Also, rip rap may be allowed if it is necessary to maintain the physical integrity of the stream, but the applicant must provide written justification and any calculations used to determine the extent of rip-rap coverage requested.
7. Compensatory mitigation of 55.38 acres shall be done for 27.69 acres of impacts to jurisdictional wetlands in the Yadkin River Basin. In addition, 2.45 acres of compensatory mitigation shall be provided to offset 2.12 acres of jurisdictional wetlands in the Lumber River Basin. The mitigation shall be provided as described below.

Mitigation Site	Acres of WL Debited from Site	Type of Mitigation	River Basin	Acres of Mitigation Credited
Key Branch Mitigation Site	55.38	Restoration	Yadkin	55.38
Myrick Pond Mitigation Site	2.45	Restoration	Lumber	2.45
Total				57.83

8. For the construction activities for the bridge located from Station 190+00 to 191+53, the NCDOT shall strictly adhere to sediment and erosion control Best Management Practices as described for High Quality Waters entitled "Design Standards in Sensitive Watersheds" (15A NCAC 04B .0024) throughout design and construction of the project.



9. Compensatory mitigation for impacts to streams shall be done for 7249 linear feet of stream impact in the Yadkin Basin and 351 linear feet of impact in the Lumber Basin, at a replacement ratio of 1:1. The mitigation shall be provided as described below.

Mitigation Site	Linear Feet of Streams Debited from Site	Type of Mitigation	River Basin	Acres of Mitigation Credited
Sites 3 & 6 in Section B	676	Onsite Restoration	Yadkin	676
Key Branch Mitigation Site	6183	Offsite Restoration	Yadkin	6183
Haithcock Mitigation Site	390	Offsite Restoration	Yadkin	390
Myrick Pond Site	351	Onsite Restoration	Lumber	351
Total				7600

10. A final plan for the Haithcock Mitigation Site shall be submitted, and written approval received from the NC Division of Water Quality, by October 1, 2003.
11. A final plan for the Key Branch Mitigation Site shall be submitted, and written approval received from the NC Division of Water Quality, by October 1, 2003.
12. No construction activities related to the section of the Ellerbe Connector (NC 73 Extension, TIP R-3303) located in Richmond County are authorized by this certification. Prior to any construction activities related to the Ellerbe Connector (NC 73 Extension, TIP R-3303) a modification to this certification is required. A submittal of a modification request, with seven copies, and corresponding fees will have to be submitted to the North Carolina Division of Water Quality.
13. Upon completion of the project, the NCDOT shall complete and return the enclosed "Certification of Completion Form" to notify DWQ when all work included in the 401 Certification has been completed. The responsible party shall complete the attached form and return it to the 401/Wetlands Unit of the Division of Water Quality upon completion of the project.
14. Placement of culverts and other structures in waters, streams, and wetlands must be placed below the elevation of the streambed to allow low flow passage of water and aquatic life unless it can be shown to DWQ that providing passage would be impractical. Design and placement of culverts and other structures including temporary erosion control measures shall not be conducted in a manner that may result in disequilibrium of wetlands or stream beds or banks, adjacent to or upstream and down stream of the above structures. The applicant is required to provide evidence that the equilibrium shall be maintained if requested in writing by DWQ.
15. The permittee shall require its contractors (and/or agents) to comply with all of the terms of this certification, and shall provide each of its contractors (and/or agents) a copy of this certification.



Michael F. Easley, Governor
William G. Ross Jr., Secretary
North Carolina Department of Environment and Natural Resources
Alan W. Klimek, P.E. Director

Violations of any condition herein set forth shall result in revocation of this Certification and may result in criminal and/or civil penalties. This Certification shall become null and void unless the above conditions are made conditions of the Federal 404 and/or Coastal Area Management Act Permit. This Certification shall expire upon the expiration of the 404 or CAMA permit.

If this Certification is unacceptable to you have the right to an adjudicatory hearing upon written request within sixty (60) days following receipt of this Certification. This request must be in the form of a written petition conforming to Chapter 150B of the North Carolina General Statutes and filed with the Office of Administrative Hearings, P.O. Box 27447, Raleigh, N.C. 27611-7447. If modifications are made to an original Certification, you have the right to an adjudicatory hearing on the modifications upon written request within sixty (60) days following receipt of the Certification. Unless such demands are made, this Certification shall be final and binding.

This the 1st day of April 2003

DIVISION OF WATER QUALITY

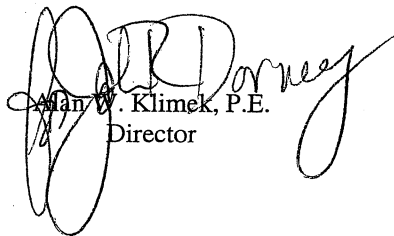
Alan W. Klimek, P.E.
Director

WQC No. 3419



Michael F. Easley, Governor
William G. Ross Jr., Secretary
North Carolina Department of Environment and Natural Resources
Alan W. Klimek, P.E. Director

Certificate of Completeness

DWQ Project No.: _____ County: _____

Applicant: _____

Project Name: _____

Date of Issuance of 401 Water Quality Certification: _____

Certificate of Completion

Upon completion of all work approved within the 401 Water Quality Certification or applicable Buffer Rules, and any subsequent modifications, the applicant is required to return this certificate to the 401/Wetlands Unit, North Carolina Division of Water Quality, 1650 Mail Service Center, Raleigh, NC, 27699-1621. This form may be returned to DWQ by the applicant, the applicant's authorized agent, or the Project Engineer. It is not necessary to send certificates from all of these.

Applicant's Certification

I, _____, hereby state that, to the best of my abilities, due care and diligence was used in the observation of the construction such that the construction was observed to be built within substantial compliance and intent of the 401 Water Quality Certification and Buffer Rules, the approved plans and specifications, and other supporting materials.

Signature: _____

Date: _____

Agent's Certification

I, _____, hereby state that, to the best of my abilities, due care and diligence was used in the observation of the construction such that the construction was observed to be built within substantial compliance and intent of the 401 Water Quality Certification and Buffer Rules, the approved plans and specifications, and other supporting materials.

Signature: _____

Date: _____

If this project was designed by a Certified Professional

I, _____, as a duly registered Professional _____ (i.e., Engineer, Landscape Architect, Surveyor, ect.) in the State of North Carolina, having been authorized to observe (periodically, weekly, full time) the construction of the project, for the Permittee hereby state that, to the best of my abilities, due care and diligence was used in the observation of the construction such that the construction was observed to be built within substantial compliance and intent of the 401 Water Quality Certification and Buffer Rules, the approved plans and specifications, and other supporting materials.

Signature _____

Registration No. _____

Date _____

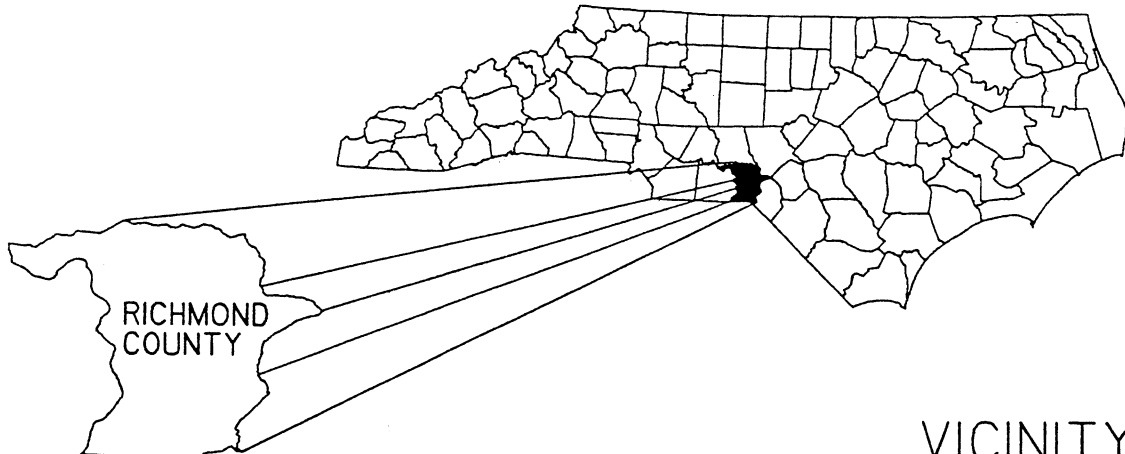

RICHMOND COUNTY

VICINITY MAP

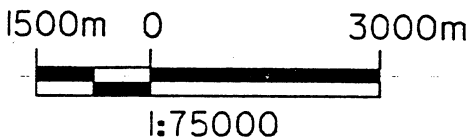
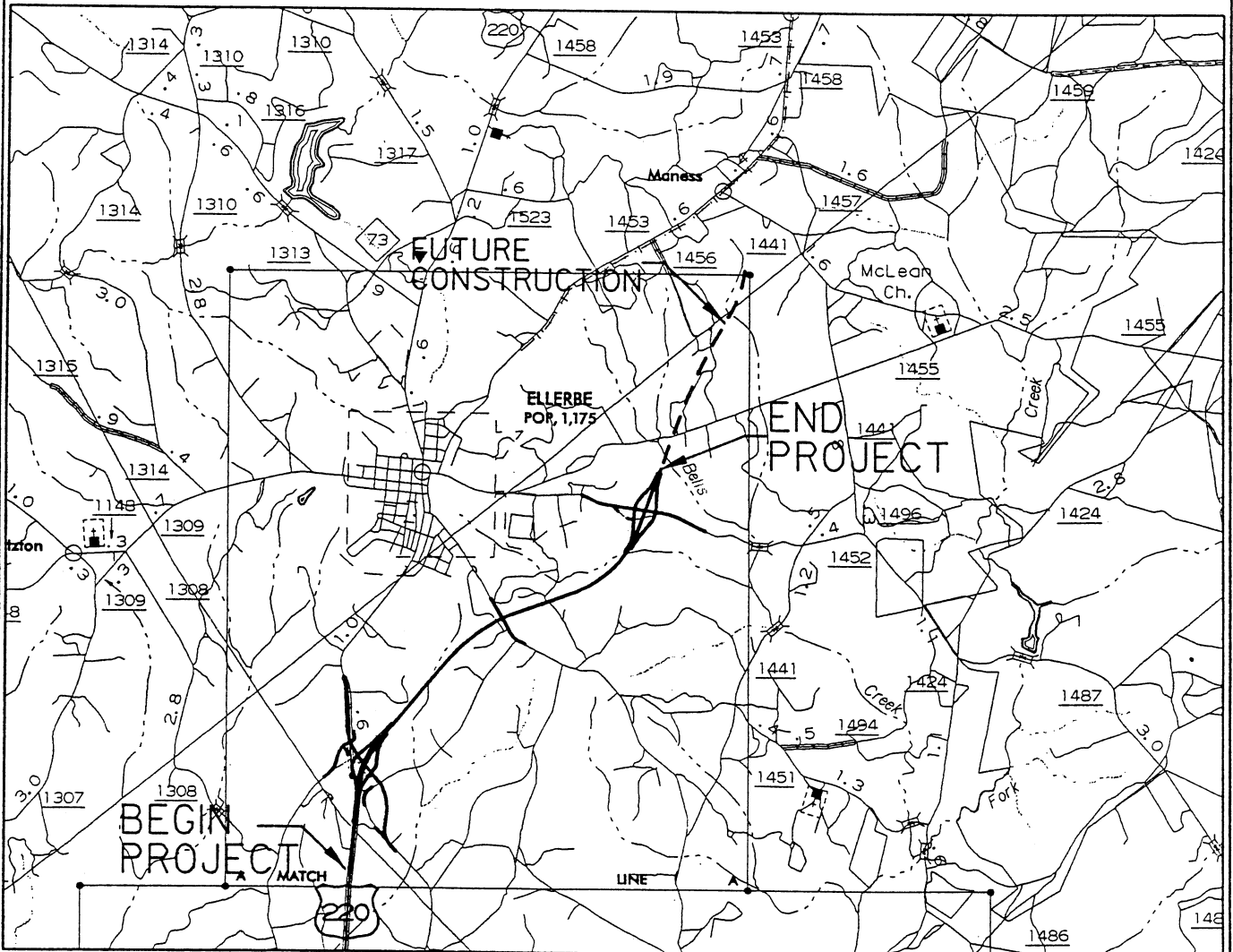













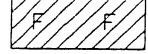

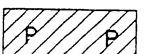
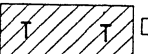

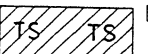
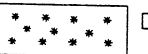
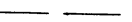
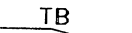
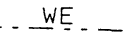
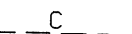
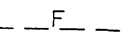

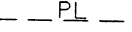
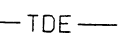
N.C. DEPT. OF TRANSPORTATION
 DIVISION OF HIGHWAYS
 RICHMOND COUNTY

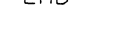
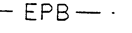
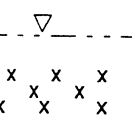
PROJECT R-2231A

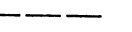
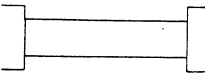
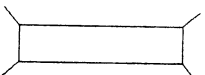
PROPOSED
 US 220 FROM SOUTH OF SR 1448
 TO SOUTH OF SR 1441

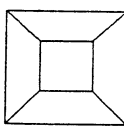
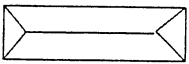
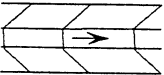
REV. 9-02 SHEET 1 OF 30

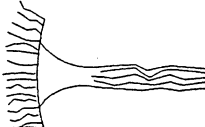
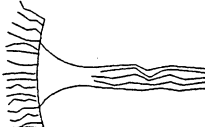
WETLAND LEGEND

-  WETLAND BOUNDARY
-  WETLAND
-  DENOTES FILL IN WETLAND
-  DENOTES FILL IN SURFACE WATER
-  DENOTES FILL IN SURFACE WATER (POND)
-  DENOTES TEMPORARY FILL IN WETLAND
-  DENOTES EXCAVATION IN WETLAND
-  DENOTES TEMPORARY FILL IN SURFACE WATER
-  DENOTES MECHANIZED CLEARING
-  FLOW DIRECTION
-  TOP OF BANK
-  EDGE OF WATER
-  PROP. LIMIT OF CUT
-  PROP. LIMIT OF FILL
-  PROP. RIGHT OF WAY
-  NATURAL GROUND
-  PROPERTY LINE
-  TEMP. DRAINAGE EASEMENT
-  PERMANENT DRAINAGE EASEMENT
-  EXIST. ENDANGERED ANIMAL BOUNDARY
-  EXIST. ENDANGERED PLANT BOUNDARY
-  WATER SURFACE
-  LIVE STAKES
-  BOULDER
-  CORE FIBER ROLLS
-  PROPOSED BRIDGE
-  PROPOSED BOX CULVERT
-  PROPOSED PIPE CULVERT
(DASHED LINES DENOTE EXISTING STRUCTURES)
-  ADJACENT PROPERTY OWNER OR PARCEL NUMBER IF AVAILABLE
-  PREFORMED SCOUR HOLE (PSH)
-  LEVEL SPREADER (LS)
-  GRASS SWALE
-  SINGLE TREE
-  WOODS LINE
-  DRAINAGE INLET
-  ROOTWAD
-  RIP RAP

N. C. DEPT. OF TRANSPORTATION
DIVISION OF HIGHWAYS
RICHMOND COUNTY
PROJECT R-2231A
US 220 FROM SOUTH OF SR 1448
TO SOUTH OF SR 1441
 SHEET 2 OF 30

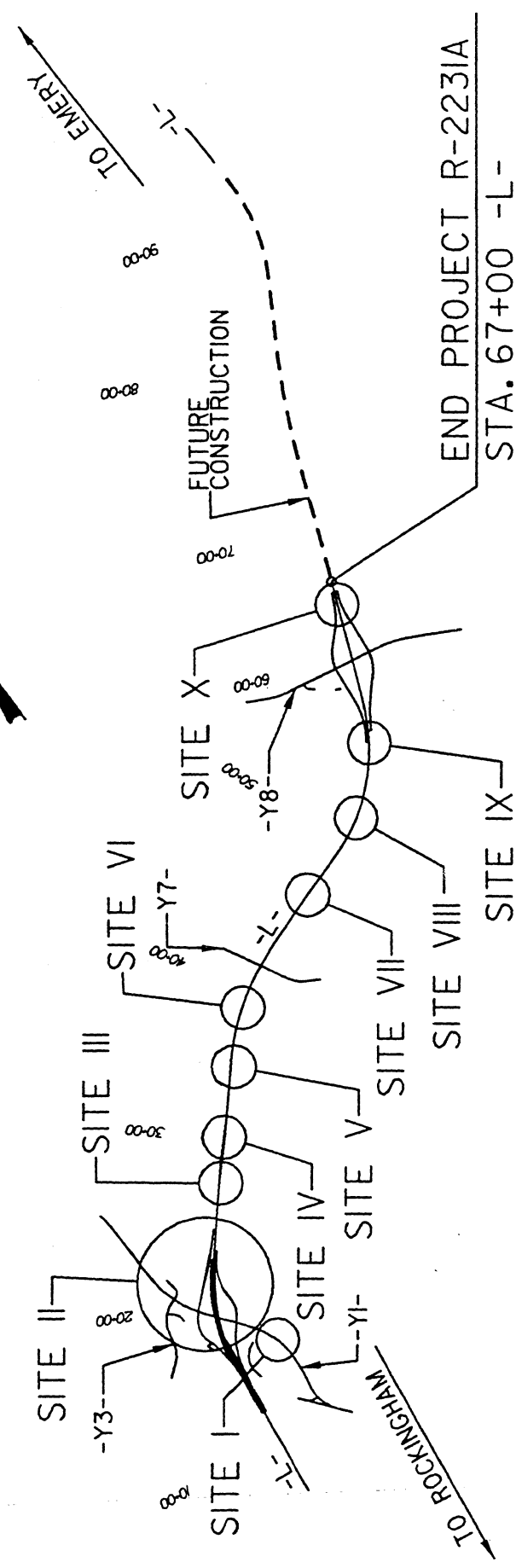
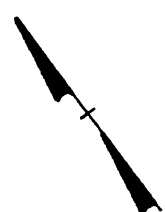

N.C. DEPT. OF TRANSPORTATION
DIVISION OF HIGHWAYS
RICHMOND COUNTY

PROJECT R-223IA

PROPOSED
US 220 FROM SOUTH OS SR 1448
TO SOUTH OF SR 1441

REV. 9-02 [SHEET 3 OF 30]

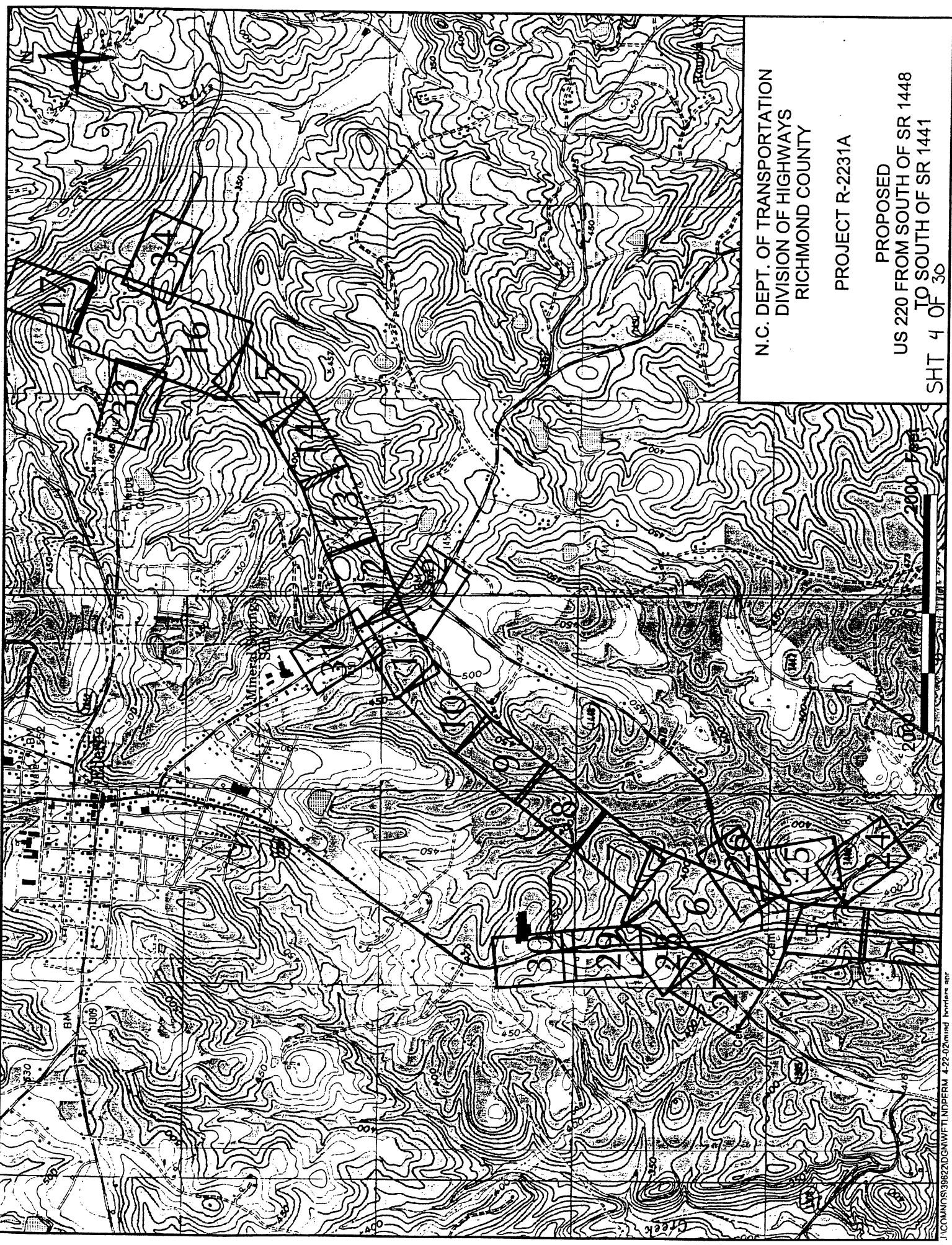

N.C. DEPT. OF TRANSPORTATION
DIVISION OF HIGHWAYS
RICHMOND COUNTY

PROJECT R-2231A

PROPOSED
US 220 FROM SOUTH OF SR 1448
TO SOUTH OF SR 1441
SHT 4 OF 30

PREFORMED SCOUR HOLE WITH LEVEL SPREADER APRON

PLAN VIEW

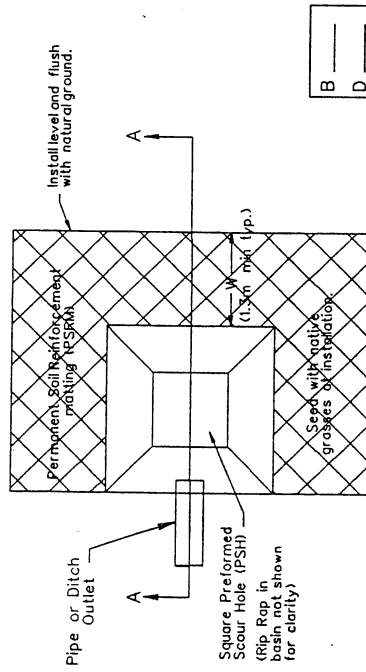

SECTION A-A

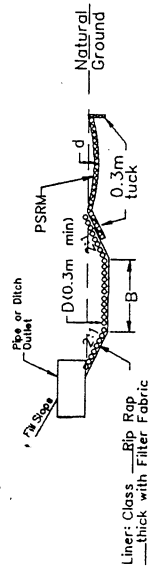

PSH LOCATIONS	B	D	W	d	DIMENSIONS
-L- STA. 29+65 RT	1	0.22m	1.3m	0.15m	3.6mx4.9m
-L- STA. 38+40 RT.	1	0.20m	1.3m	0.15m	7mx9m
-L- STA. 46+80 L.T.	1	0.30m	1.3m	0.15m	6mx7m
-L- STA. 52+40 L.T.	1	0.20m	1.3m	0.15m	7mx9m
-Y5- STA. 10+55 RT.	1	0.30m	1.3m	0.15m	7mx9m

PREFORMED SCOUR HOLE DETAIL

N.C. DEPT. OF TRANSPORTATION
DIVISION OF HIGHWAYS
RICHMOND COUNTY

PROJECT R-2231A

PROPOSED

US 220 FROM SOUTH OF SR 1448
TO SOUTH OF SR 1441

REV. 11-18-02

[SHEET 5 OF 30]

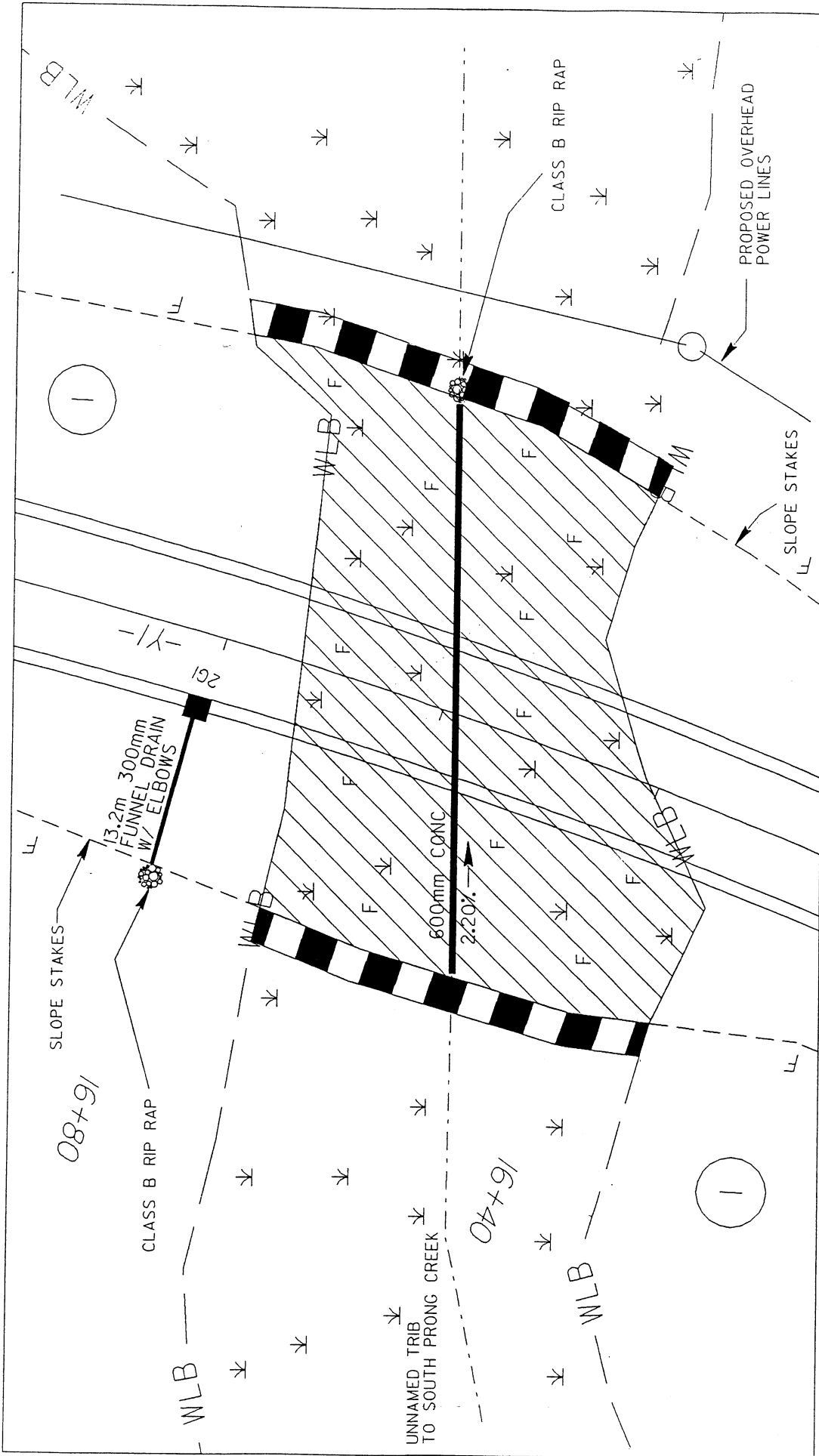

PLAN VIEW - SITE 1

-  DENOTES FILL IN WETLANDS
-  DENOTES MECHANIZED CLEARING IN WETLANDS

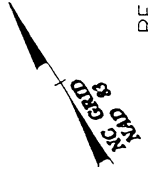
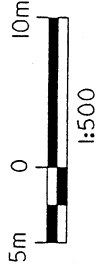

REV 10/02

N.C. DEPT. OF TRANSPORTATION
DIVISION OF HIGHWAYS
RICHMOND COUNTY

PROJECT R-2231A

PROPOSED
US 220 FROM SOUTH OF SR 1448
TO SOUTH OF SR 1441

SHEET 6 OF 30

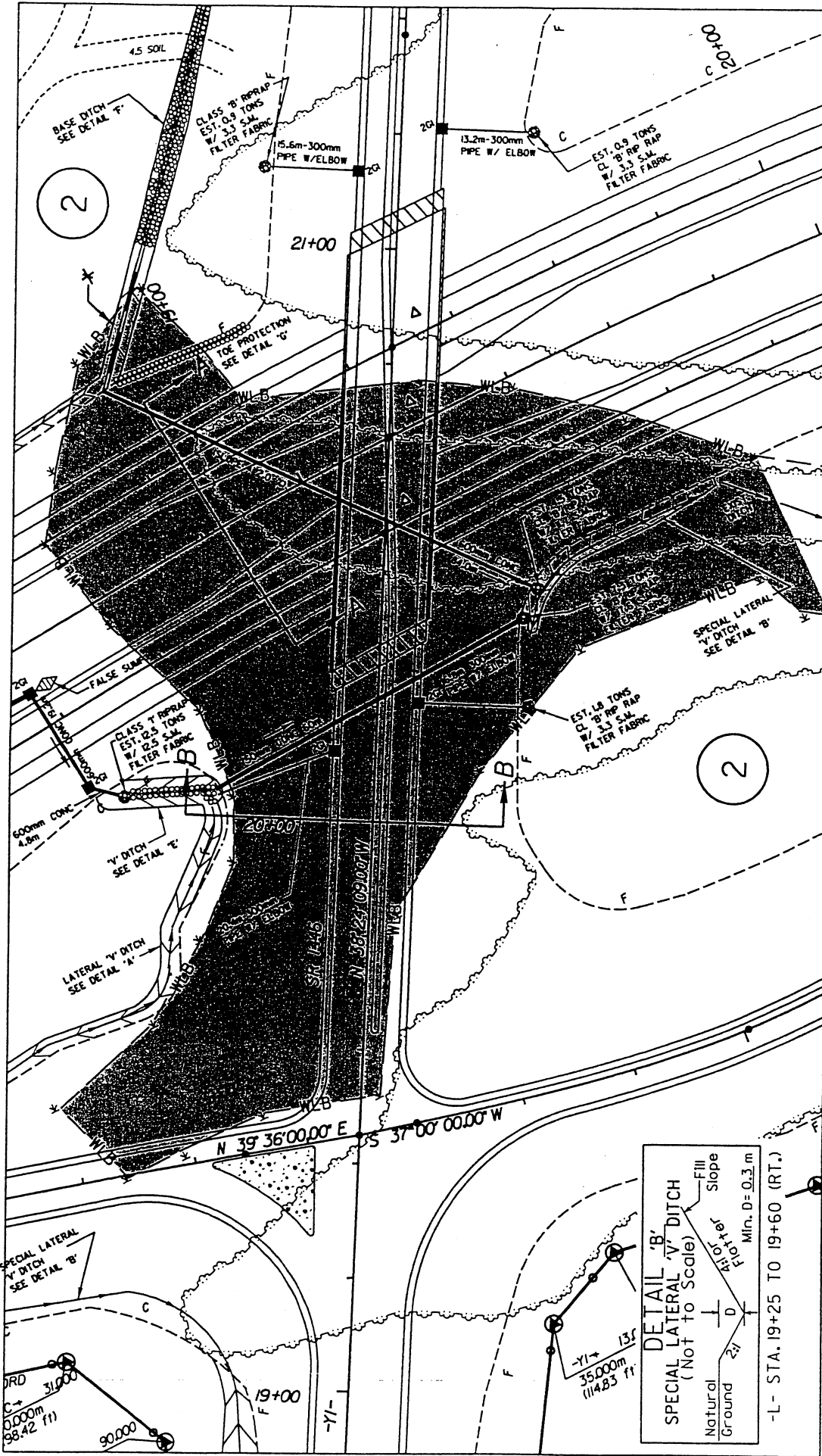

PLAN VIEW - SITE IIA

N.C. DEPT. OF TRANSPORTATION
 DIVISION OF HIGHWAYS
 RICHMOND COUNTY

PROJECT R-2231A

PROPOSED
 US 220 FROM SOUTH OF SR 1448
 TO SOUTH OF SR 1441

REV. 9-02 SHEET 7 OF 30



• NO EXCAVATION AT WBL STA. 19+40 RT.
 DUE TO TOTAL WETLAND IMPACT.

• DENOTES FILL IN WETLANDS



• NO MECHANIZED CLEARING AT WBL
 STA. 18+80 LT. AND 19+40 RT. DUE
 TO TOTAL WETLAND IMPACT.

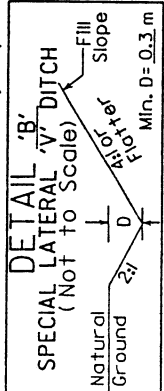

-L- STA. 19+25 TO 19+60 (RT.)

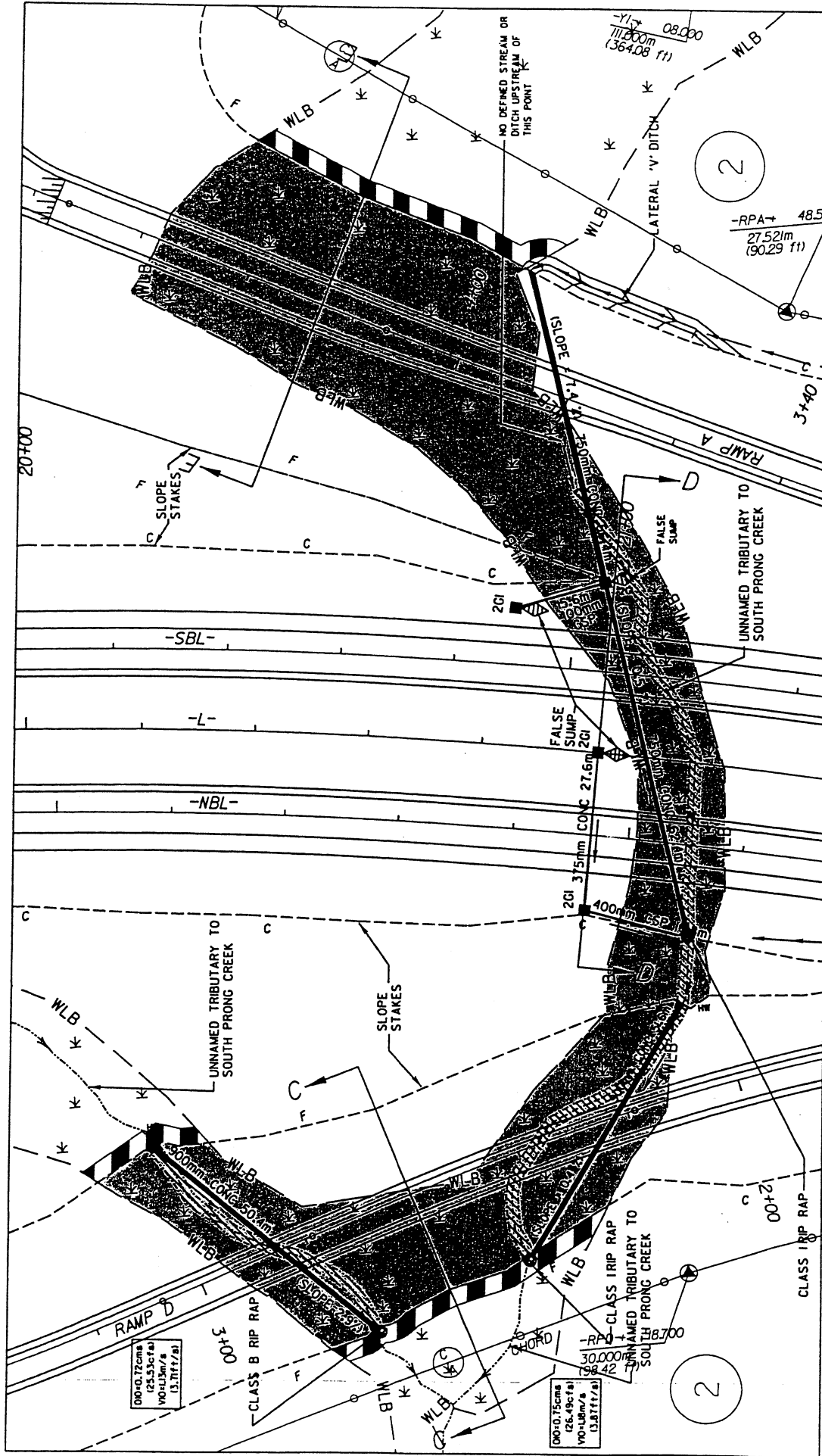

PLAN VIEW - SITE IB



N.C. DEPT. OF TRANSPORTATION
 DIVISION OF HIGHWAYS
 RICHMOND COUNTY

PROJECT R-2231A

PROPOSED
 US 220 FROM SOUTH OF SR 1448
 TO SOUTH OF SR 1441

REV. 9-02

SHEET 8 OF 30

-  DENOTES FILL IN WETLANDS
-  DENOTES MECHANIZED CLEARING IN WETLANDS
-  DENOTES FILL SURFACE WATERS

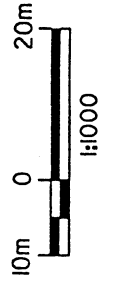
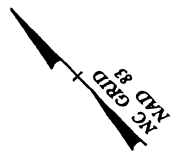

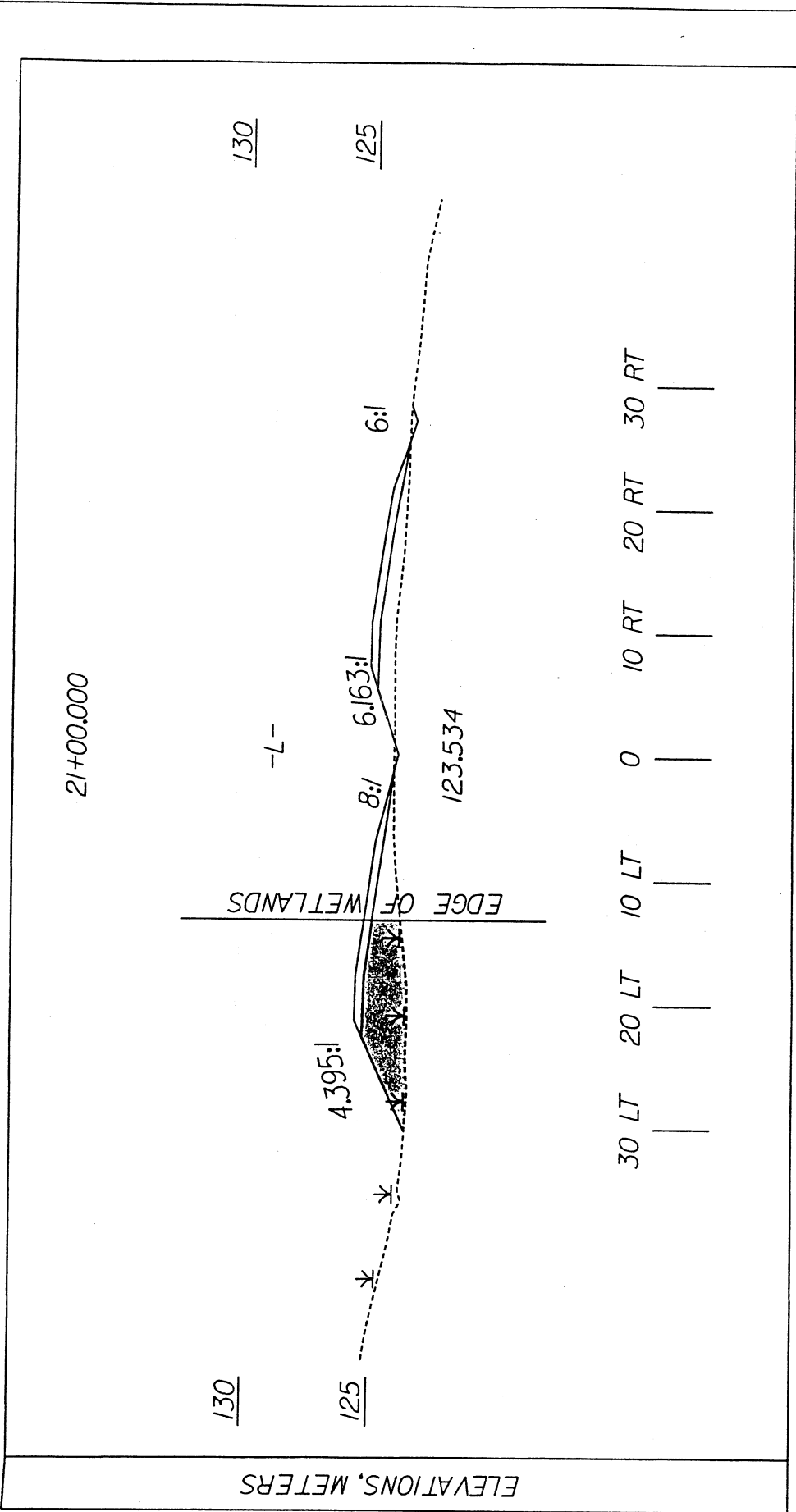

SECTION -D- SITE IIB

DENOTES FILL IN WETLANDS

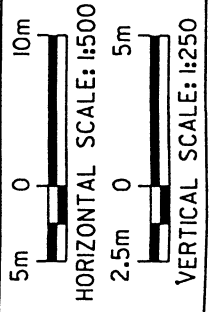

N.C. DEPT. OF TRANSPORTATION
DIVISION OF HIGHWAYS
RICHMOND COUNTY

PROJECT R-2231A

PROPOSED
US 220 FROM SOUTH OF SR 1448
TO SOUTH OF SR 1441

REV. 9-02

SHEET 9 OF 30

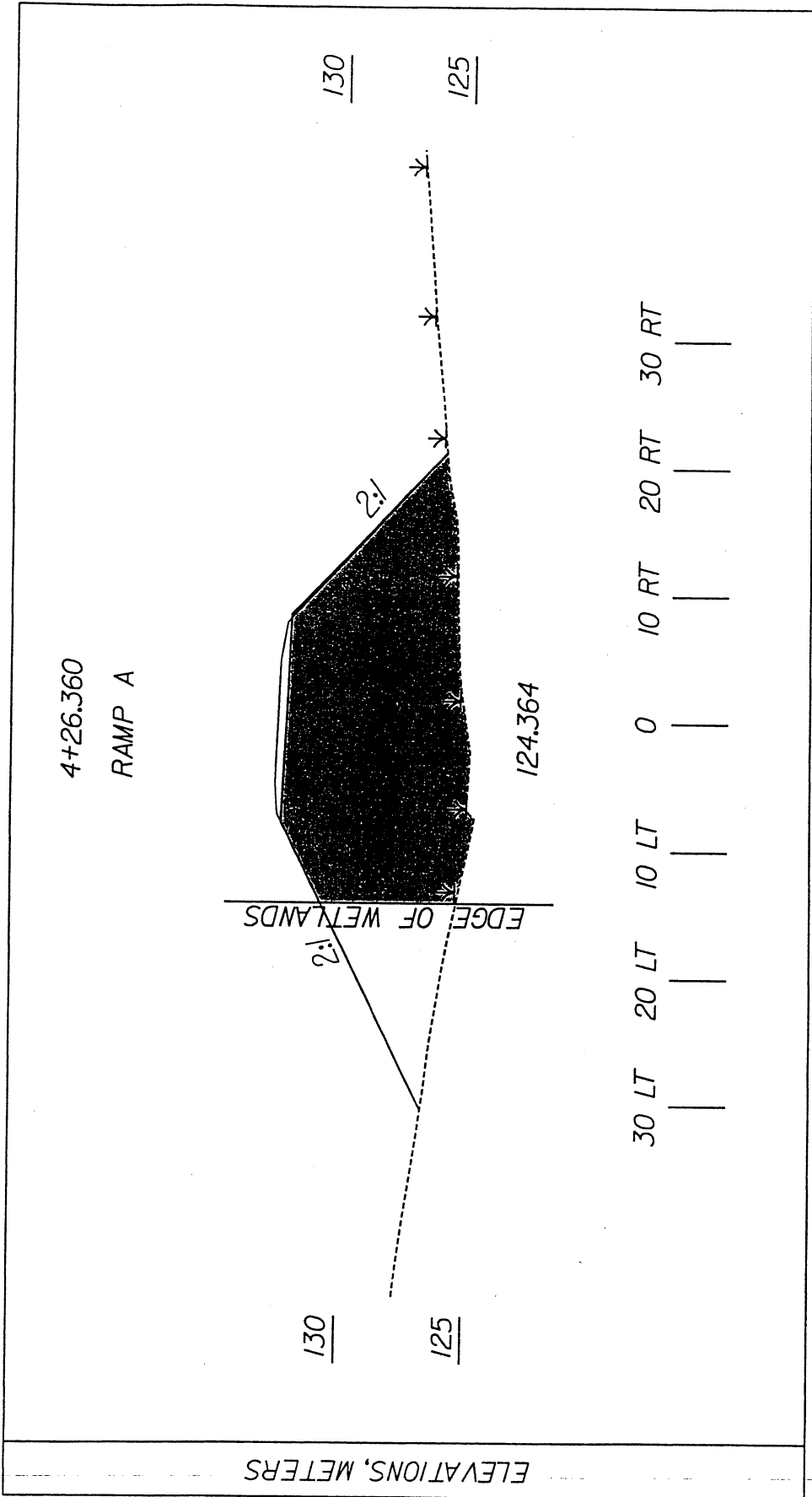

SECTION -E- SITE IIB

N.C. DEPT. OF TRANSPORTATION
 DIVISION OF HIGHWAYS
 RICHMOND COUNTY
 PROJECT R-2231A
 PROPOSED
 US 220 FROM SOUTH OF SR 1448
 TO SOUTH OF SR 1441
 REV. 9-02 SHEET 16 OF 20

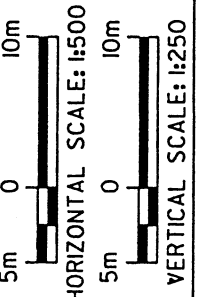



DENOTES FILL IN WETLANDS

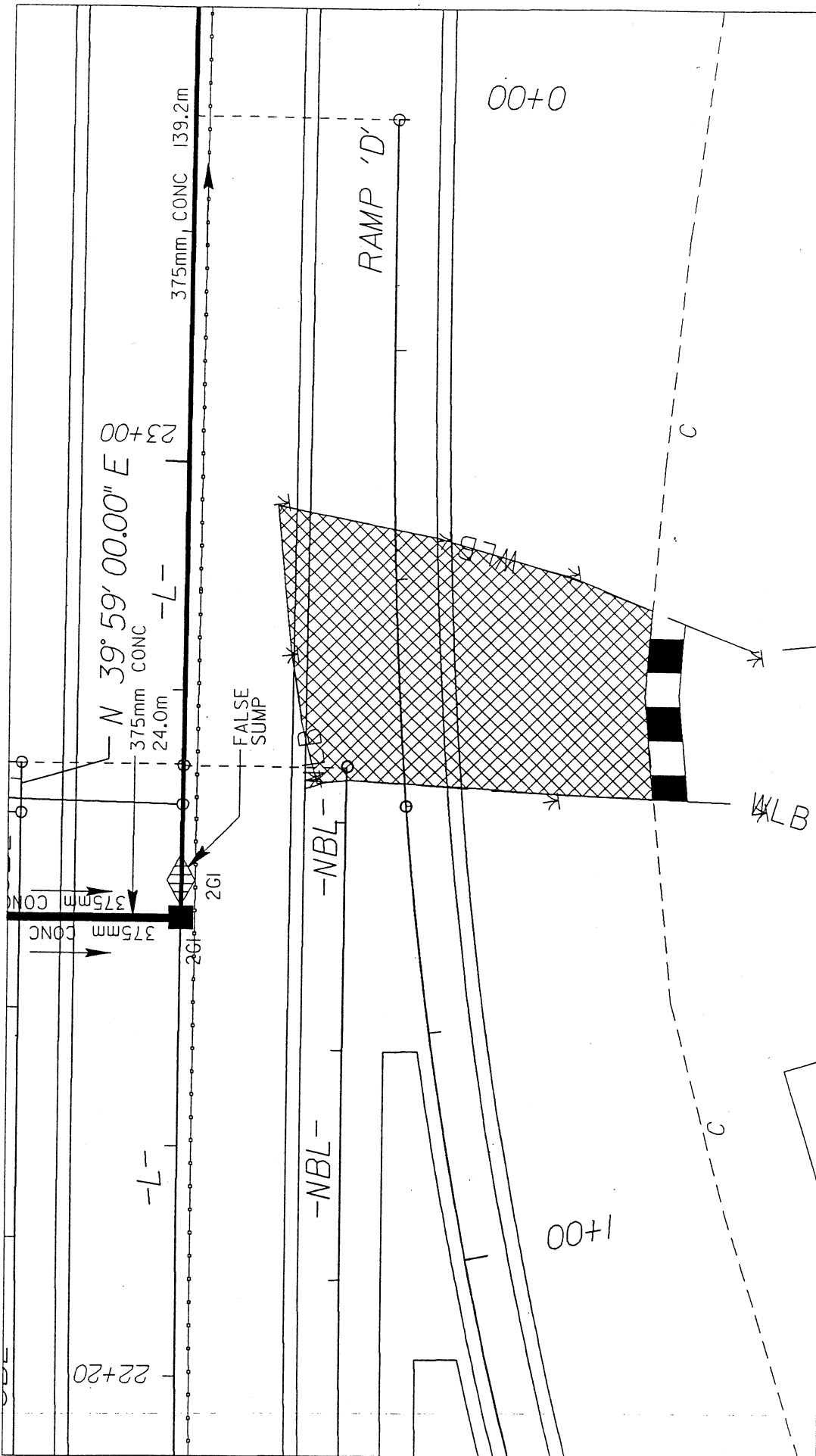

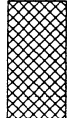

PLAN VIEW - SITE IIC

N.C. DEPT. OF TRANSPORTATION
 DIVISION OF HIGHWAYS
 RICHMOND COUNTY
 PROJECT R-2231A
 PROPOSED
 US 220 FROM SOUTH OF SR 1448
 TO SOUTH OF SR 1441

-  DENOTES UNDERCUT IN WETLANDS
-  DENOTES MECHANIZED TEMPORARY CLEARING IN WETLANDS

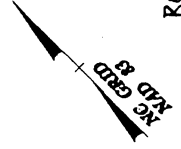
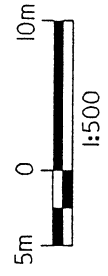

REV. 9/02

SHEET 17 OF 30

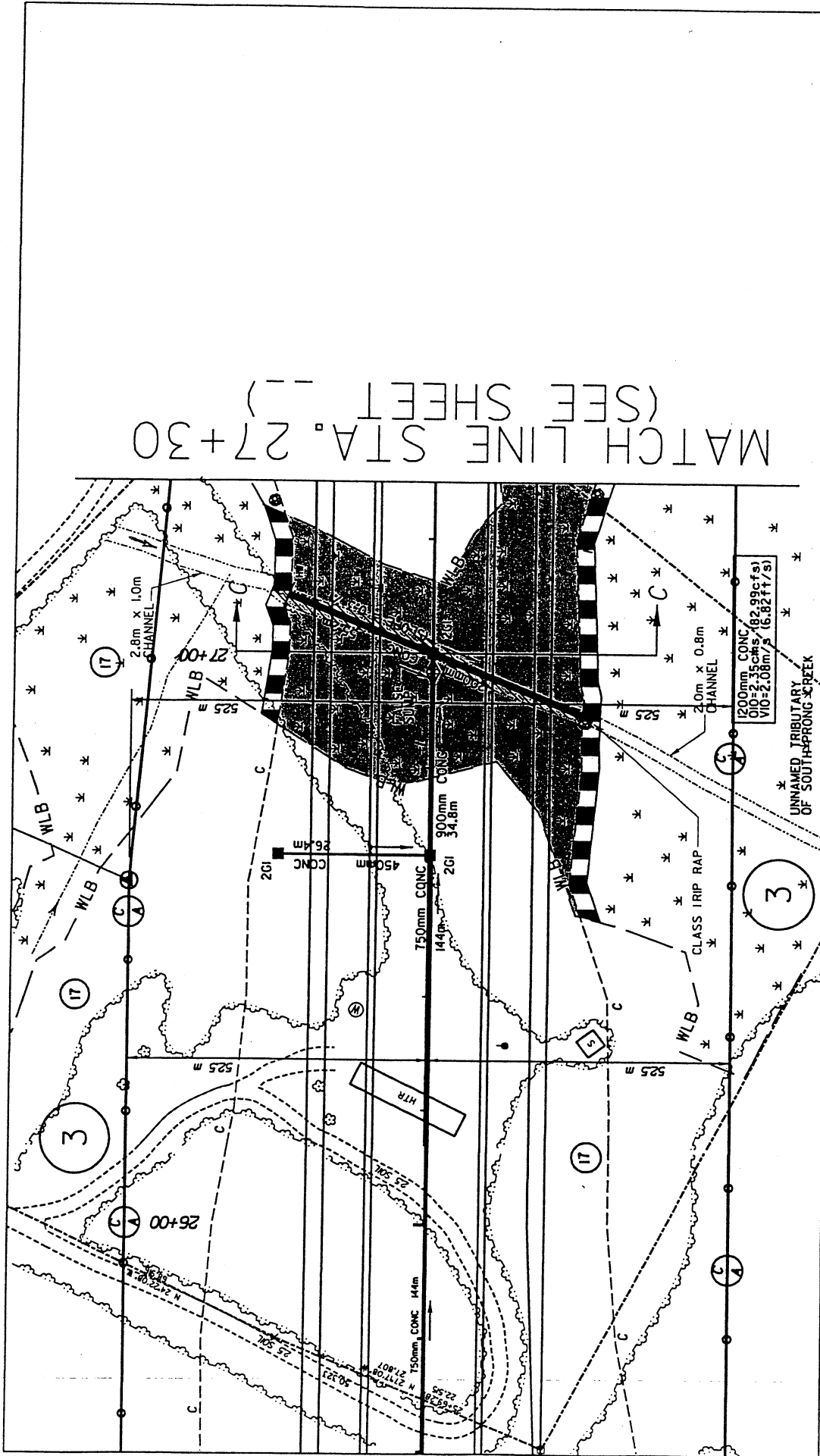



MATCH LINE STA. 27+30
(SEE SHEET _____)

PLAN VIEW - SITE III

N.C. DEPT. OF TRANSPORTATION
DIVISION OF HIGHWAYS
RICHMOND COUNTY
PROJECT R-2231A
PROPOSED
US 220 FROM SOUTH OF SR 1448
TO SOUTH OF SR 1441
REV. 9-02

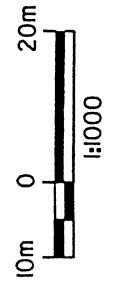
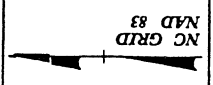

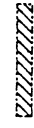
SHEET 12 OF 30

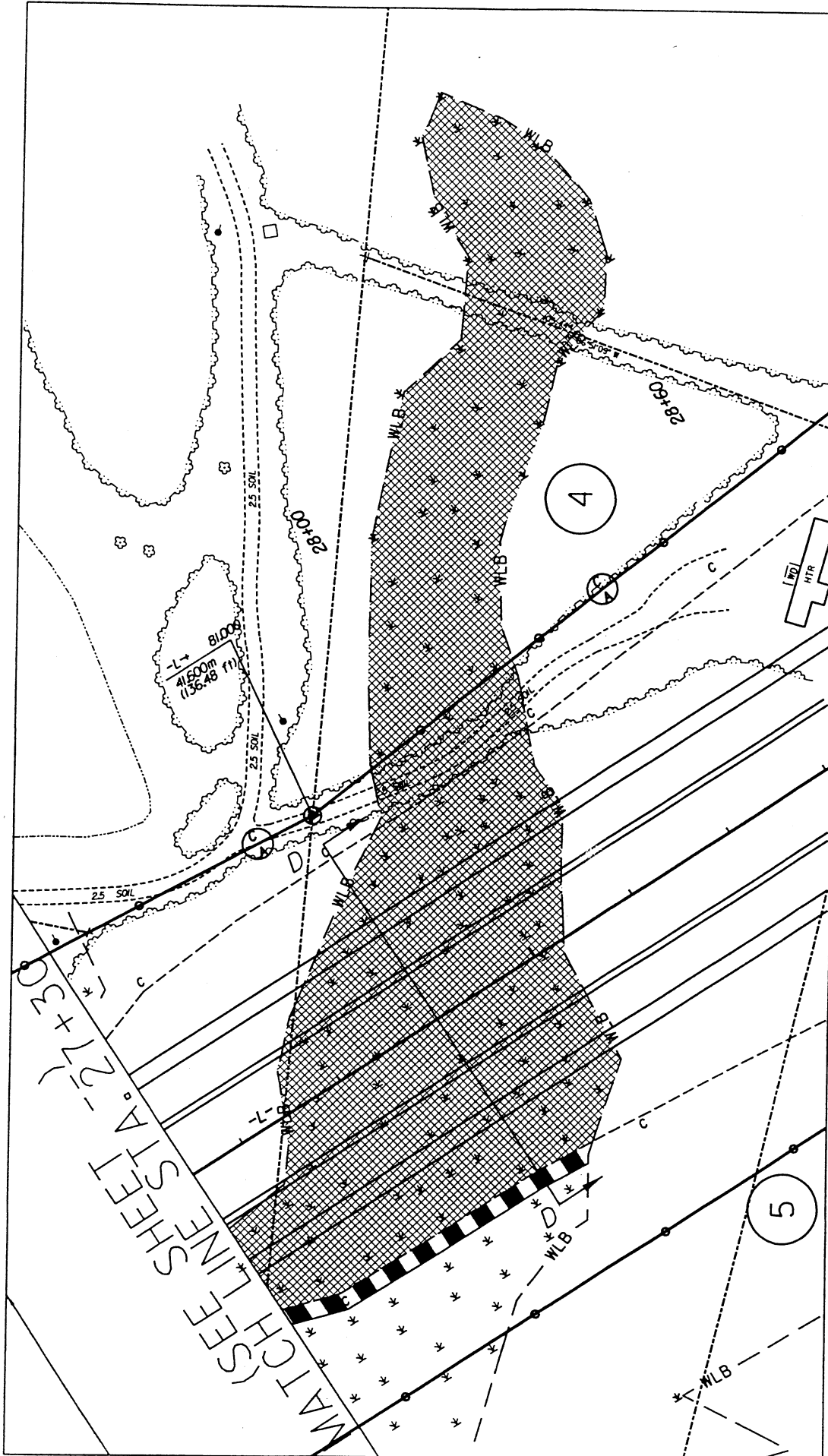

-  DENOTES FILL SURFACE WATERS
-  DENOTES FILL IN WETLANDS
-  DENOTES MECHANIZED CLEARING IN WETLANDS

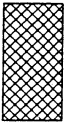

PLAN VIEW - SITE III (CONTINUED)

-  DENOTES UNDERCUT IN WETLANDS
-  DENOTES MECHANIZED CLEARING IN WETLANDS

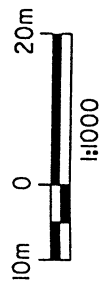
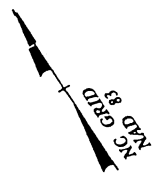

N.C. DEPT. OF TRANSPORTATION
DIVISION OF HIGHWAYS
RICHMOND COUNTY

PROJECT R-2231A

PROPOSED
US 220 FROM SOUTH OF SR 1448
TO SOUTH OF SR 1441

REV. 9-02

SHEET 13 OF 30

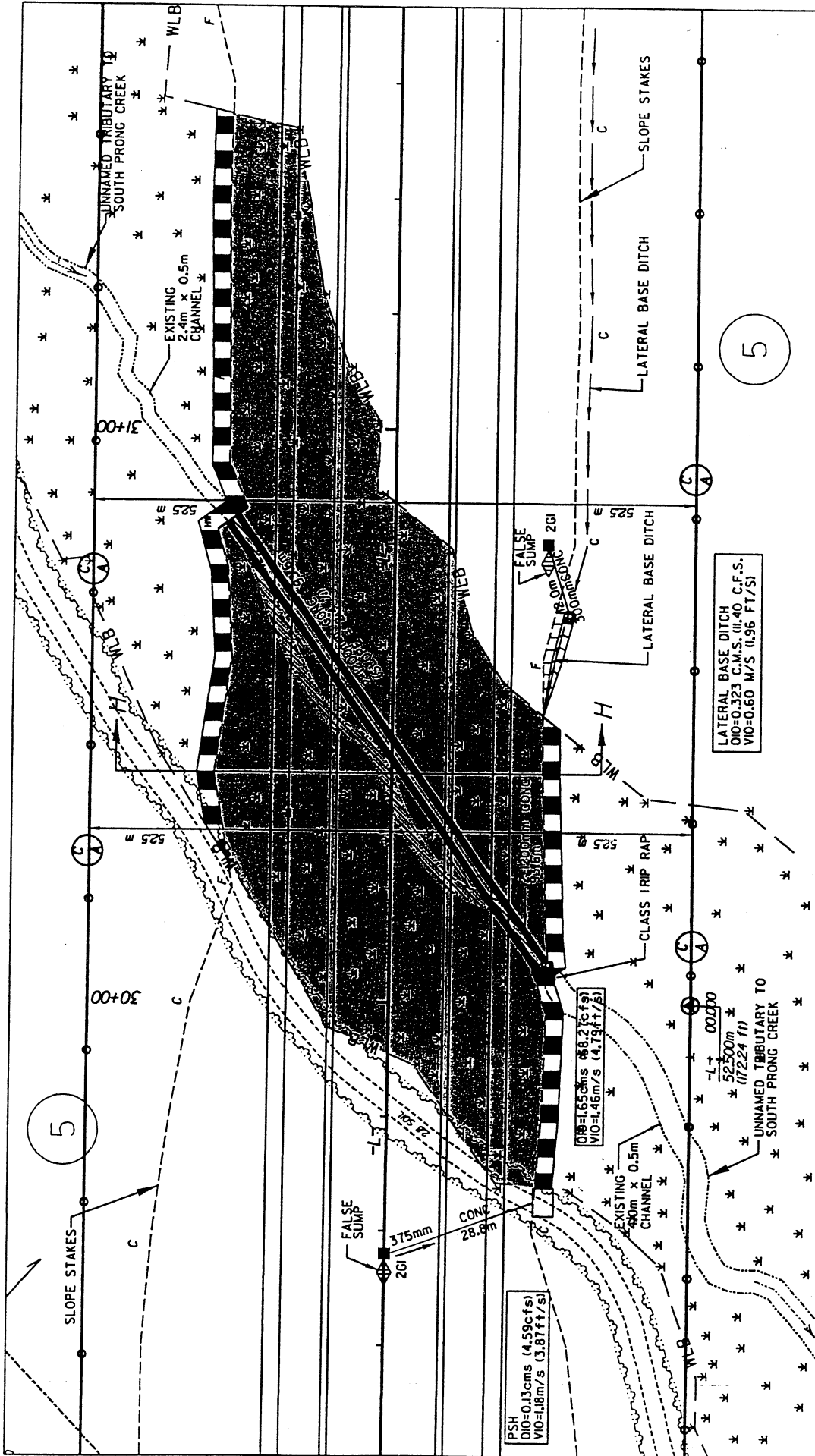

PLAN VIEW - SITE IV

N.C. DEPT. OF TRANSPORTATION
 DIVISION OF HIGHWAYS
 RICHMOND COUNTY

PROJECT R-2231A

PROPOSED
 US 220 FROM SOUTH OF SR 1448
 TO SOUTH OF SR 1441

REV. 9-02 SHEET 14 OF 30

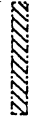
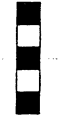

DENOTES FILL IN WETLANDS

DENOTES MECHANIZED CLEARING IN WETLANDS

DENOTES FILL SURFACE WATERS



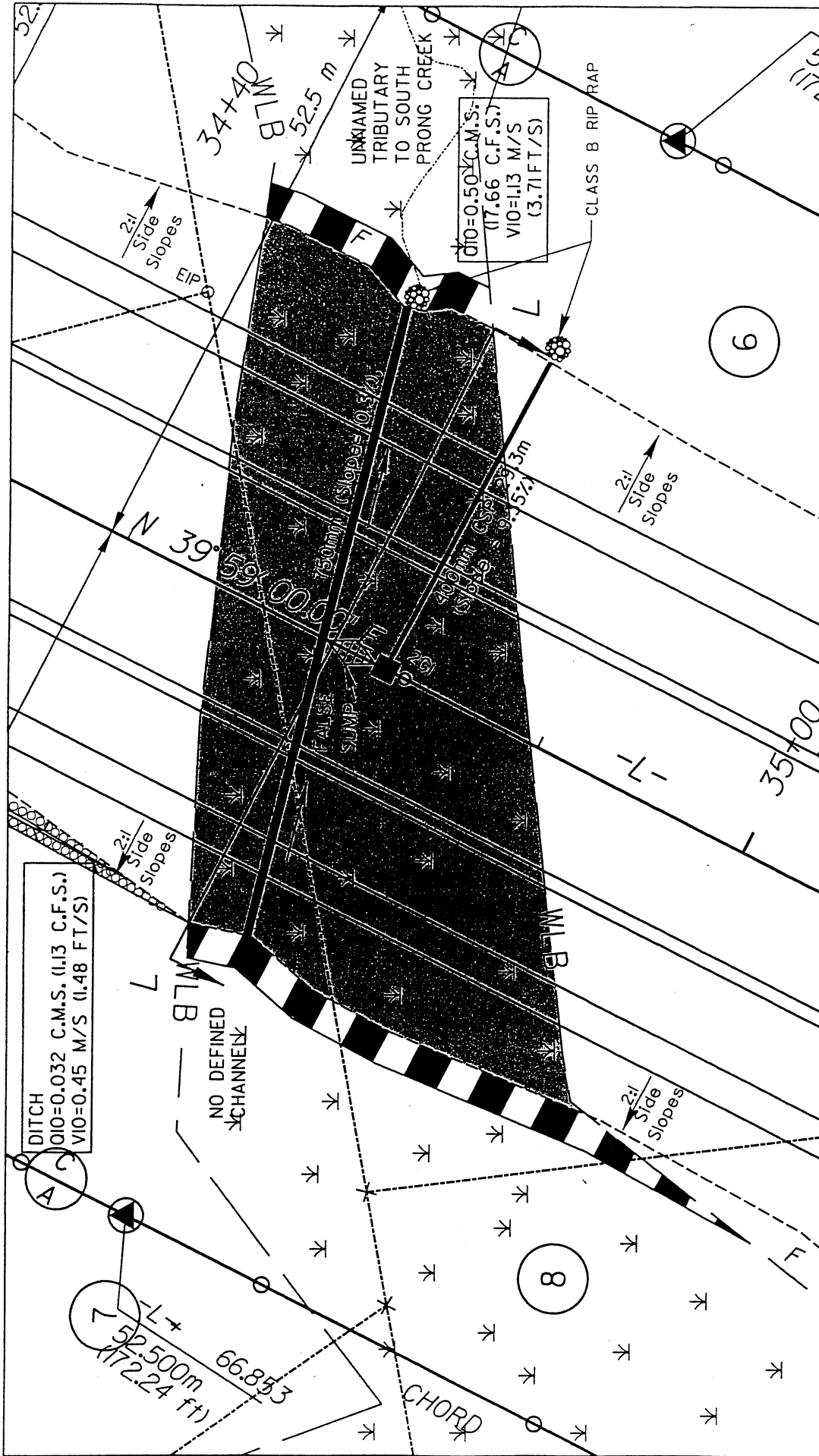

N.C. DEPT. OF TRANSPORTATION
 DIVISION OF HIGHWAYS
 RICHMOND COUNTY

PROJECT R-2231A

PROPOSED
 US 220 FROM SOUTH OF SR 1448
 TO SOUTH OF SR 1441

REV. 9-02 SHEET 15 OF 30

PLAN VIEW - SITE V

NC GRID
 NAD 83

5m 0 10m
 1:500

DENOTES FILL IN WETLANDS
 DENOTES MECHANIZED CLEARING IN WETLANDS

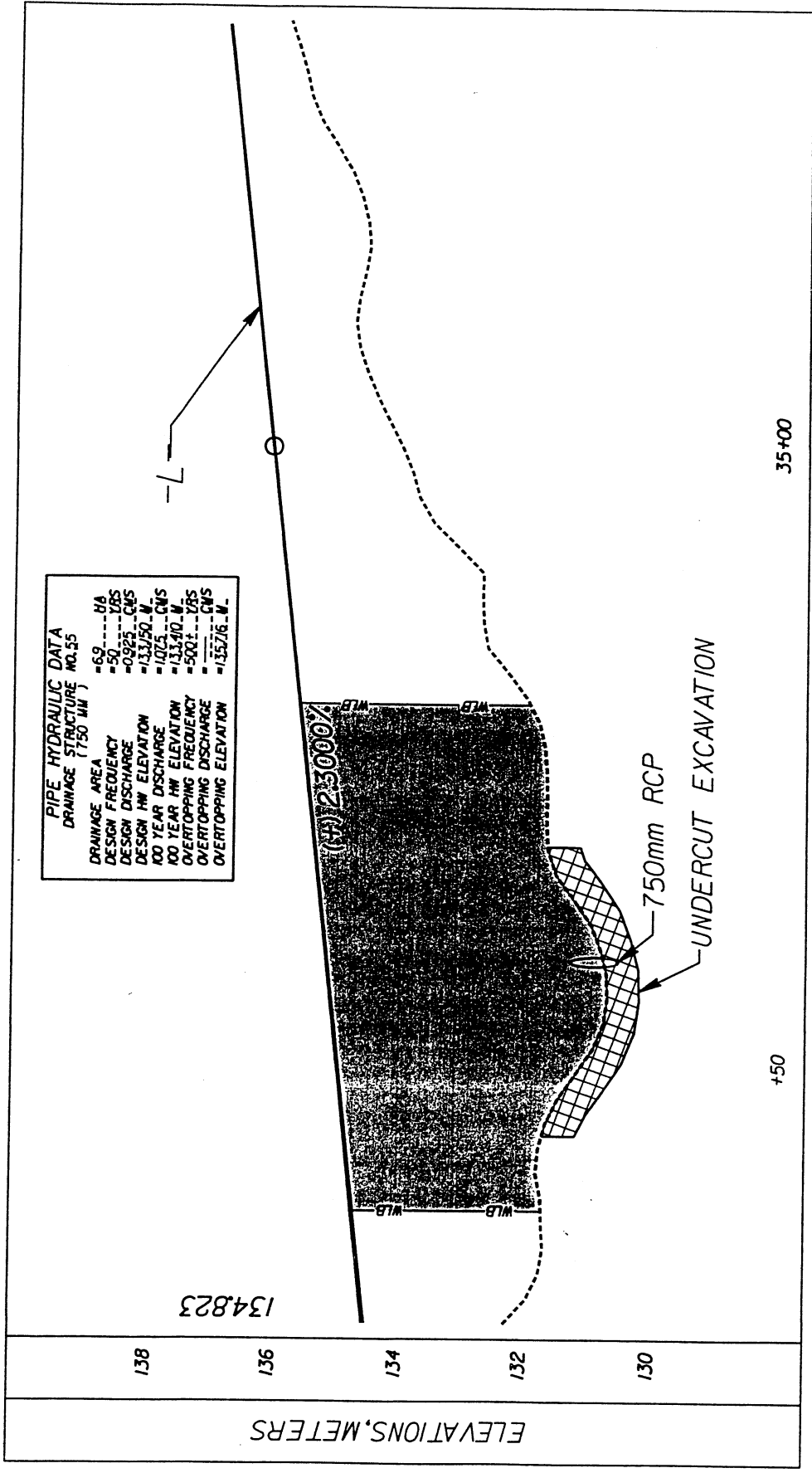

PROFILE VIEW - SITE V - L -

 DENOTES FILL IN WETLANDS
 HORIZONTAL SCALE: 1:500
 VERTICAL SCALE: 1:100

N.C. DEPT. OF TRANSPORTATION
 DIVISION OF HIGHWAYS
 RICHMOND COUNTY

PROJECT R-2231A

PROPOSED
 US 220 FROM SOUTH OF SR 1448
 TO SOUTH OF SR 1441

REV. 9-02 SHEET 16 OF 30

34+60.000

140

140

135

135

130

130

8:1 8:1

2:1

131.397

30 LT 20 LT 10 LT 0 10 RT 20 RT 30 RT



SECTION -L- SITE V



DENOTES FILL IN WETLANDS

5m 0 10m

HORIZONTAL SCALE: 1:500

2.5m 0 5m

VERTICAL SCALE: 1:250

N.C. DEPT. OF TRANSPORTATION
DIVISION OF HIGHWAYS
RICHMOND COUNTY

PROJECT R-2231A



PROPOSED
US 220 FROM SOUTH OF SR 1448
TO SOUTH OF SR 1441

REV. 9 -02

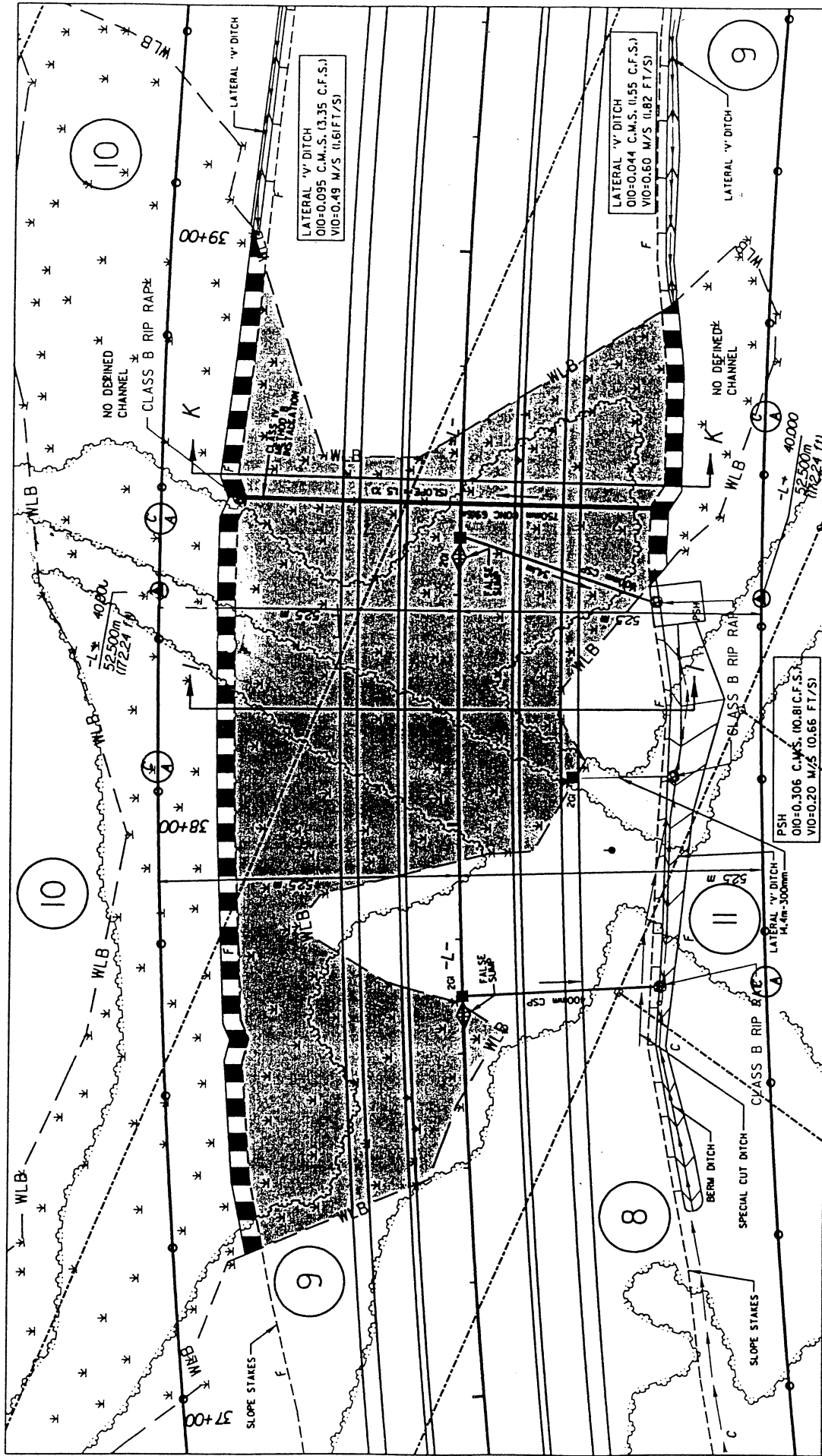
SHEET 17 OF 30



PLAN VIEW - SITE VI

-  DENOTES FILL IN WETLANDS
-  DENOTES MECHANIZED CLEARING IN WETLANDS

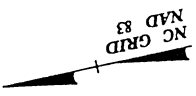
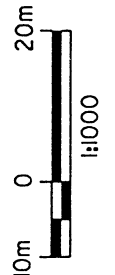

N.C. DEPT. OF TRANSPORTATION
DIVISION OF HIGHWAYS
RICHMOND COUNTY

PROJECT R-2231A

PROPOSED
US 220 FROM SOUTH OF SR 1448
TO SOUTH OF SR 1441

REV. 9-02 SHEET 18 OF 30

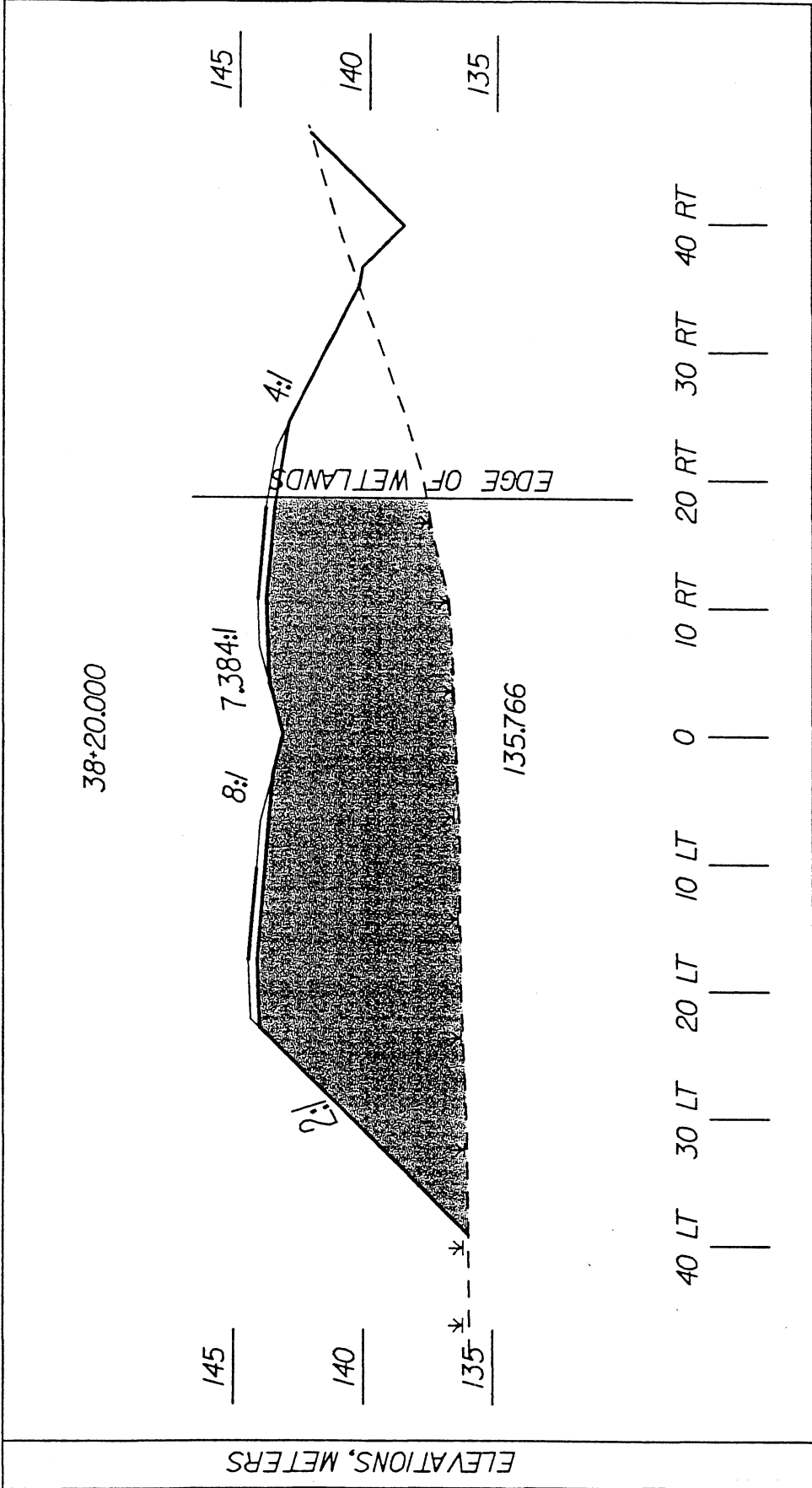

ELEVATIONS, METERS

SECTION -|- SITE VI

DENOTES FILL IN WETLANDS

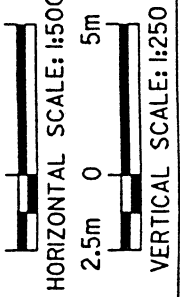

N.C. DEPT. OF TRANSPORTATION
DIVISION OF HIGHWAYS
RICHMOND COUNTY

PROJECT R-2231A

PROPOSED
US 220 FROM SOUTH OF SR 1448
TO SOUTH OF SR 1441

REV. 9-02 SHEET 79 OF 30

TBM 105
 RR SPIKE IN BASE OF 600 mm PINE
 9.5 m RT OF
 -L- STA 37+20.000
 EL: 141.200

PIPE HYDRAULIC DATA
 DRAINAGE STRUCTURE NO. 56

DRAINAGE AREA	- 7.7	HA
DESIGN FREQUENCY	- 50	YRS
DESIGN DISCHARGE	- 0.962	CMS
DESIGN HW ELEVATION	- 137.83	M
100 YEAR DISCHARGE	- 1.18	CMS
100 YEAR HW ELEVATION	- 138.075	M
OVERTOPPING FREQUENCY	- 500	YRS
OVERTOPPING DISCHARGE	- 1.44054	CMS
OVERTOPPING ELEVATION	- 141.054	M

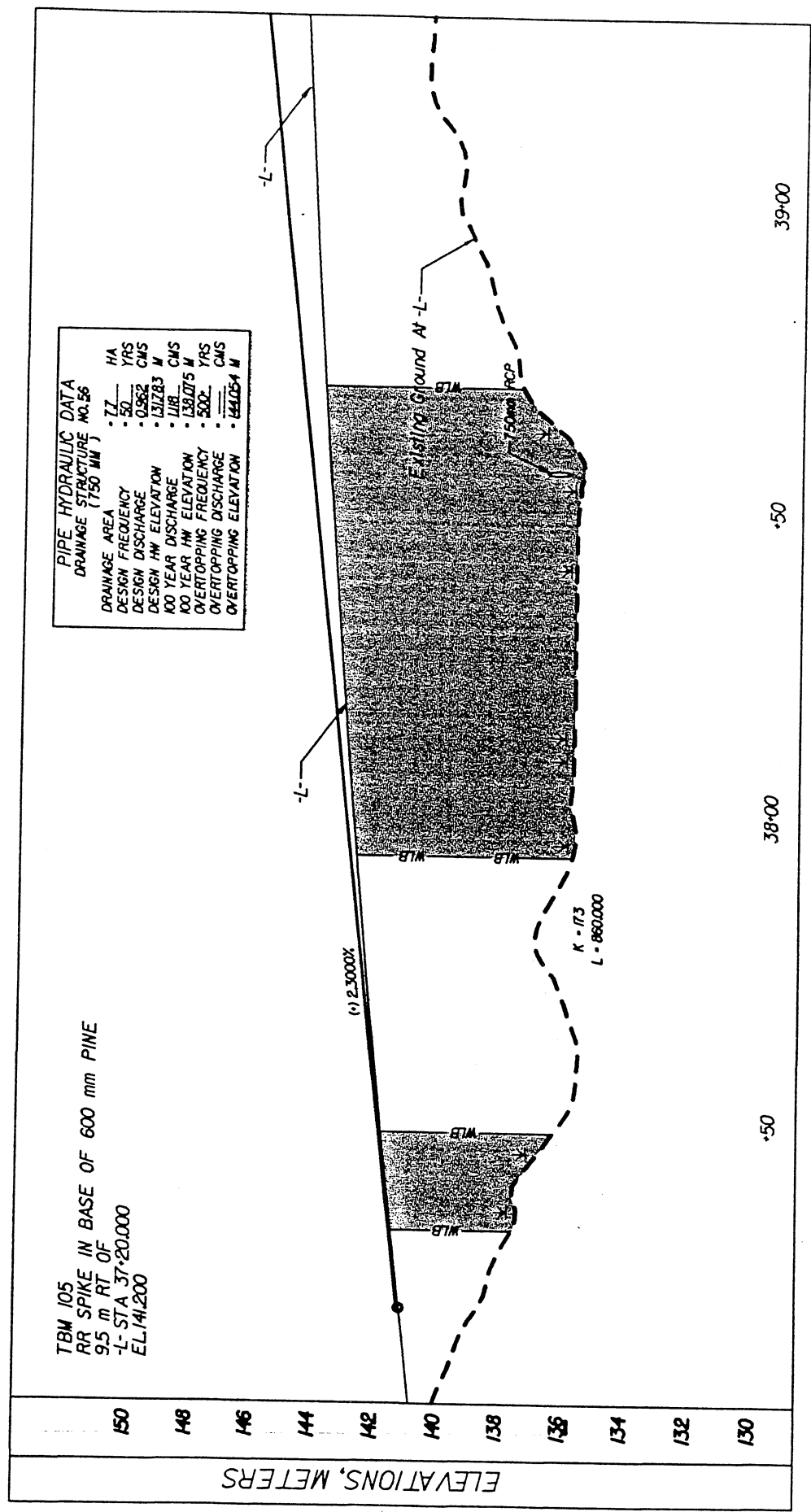

PROFILE VIEW - SITE VI

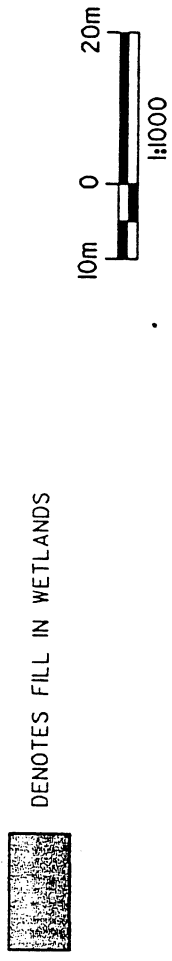

N.C. DEPT. OF TRANSPORTATION
 DIVISION OF HIGHWAYS
 RICHMOND COUNTY

PROJECT R-2231A

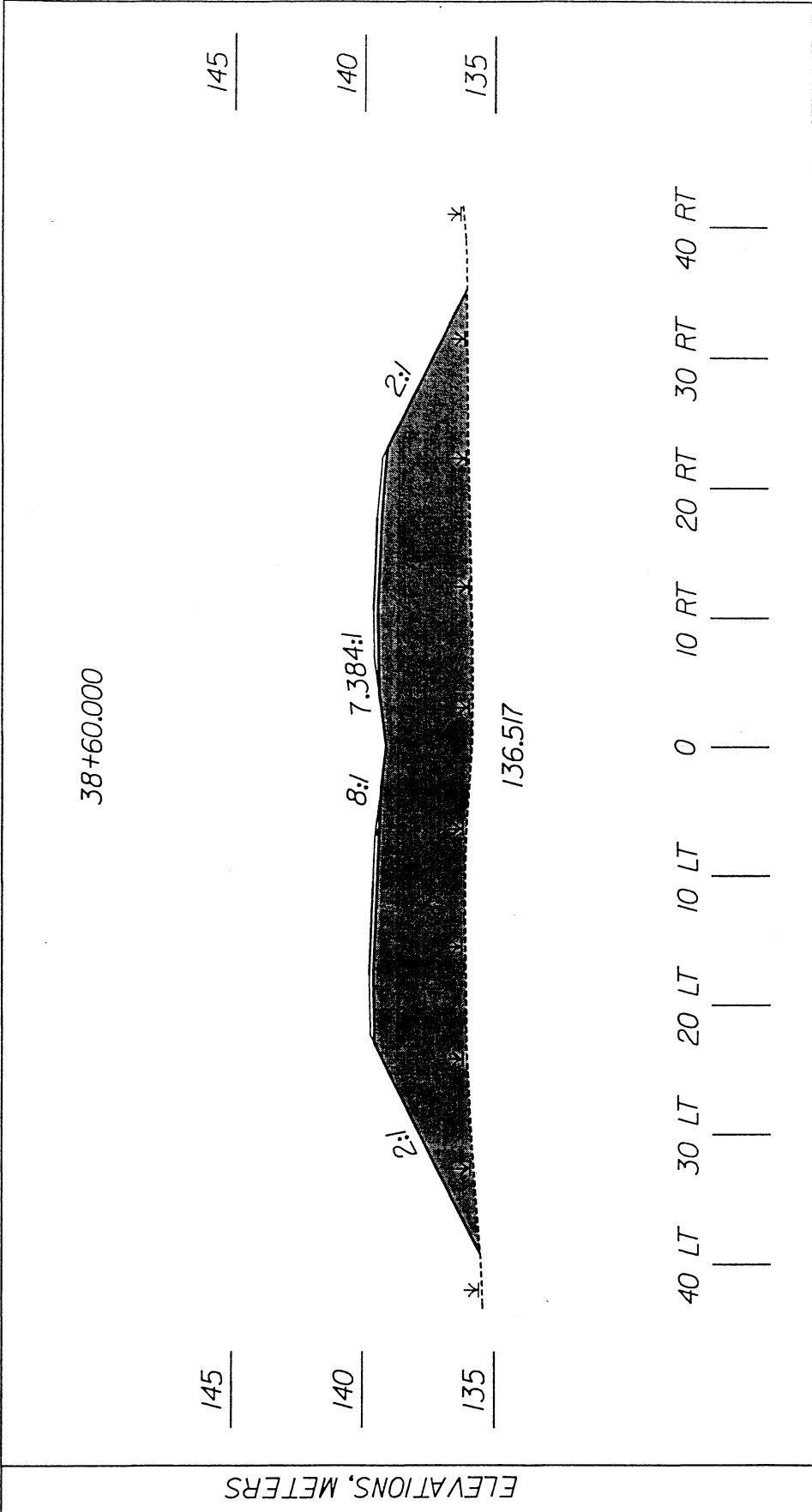

PROPOSED
 US 220 FROM SOUTH OF SR 1448
 TO SOUTH OF SR 1441

REV. 9-02 SHEET 20 OF 30



SECTION -K- SITE VI

 DENOTES FILL IN WETLANDS

 HORIZONTAL SCALE: 1:500
 VERTICAL SCALE: 1:250

N.C. DEPT. OF TRANSPORTATION
 DIVISION OF HIGHWAYS
 RICHMOND COUNTY

PROJECT R-2231A
 PROPOSED
 US 220 FROM SOUTH OF SR 1448
 TO SOUTH OF SR 1441

REV. 9-02 SHEET 21 OF 30

900mmRCP	PSH
O/D=0.42cms (14.83cfs)	O/D=1.214cms (42.87cfs)
V/D=0.34m/s (1.21ft/s)	V/D=0.59m/s (1.94ft/s)
1200mmRCP	
O/D=0.84cms (29.59cfs)	
V/D=0.40m/s (1.31ft/s)	

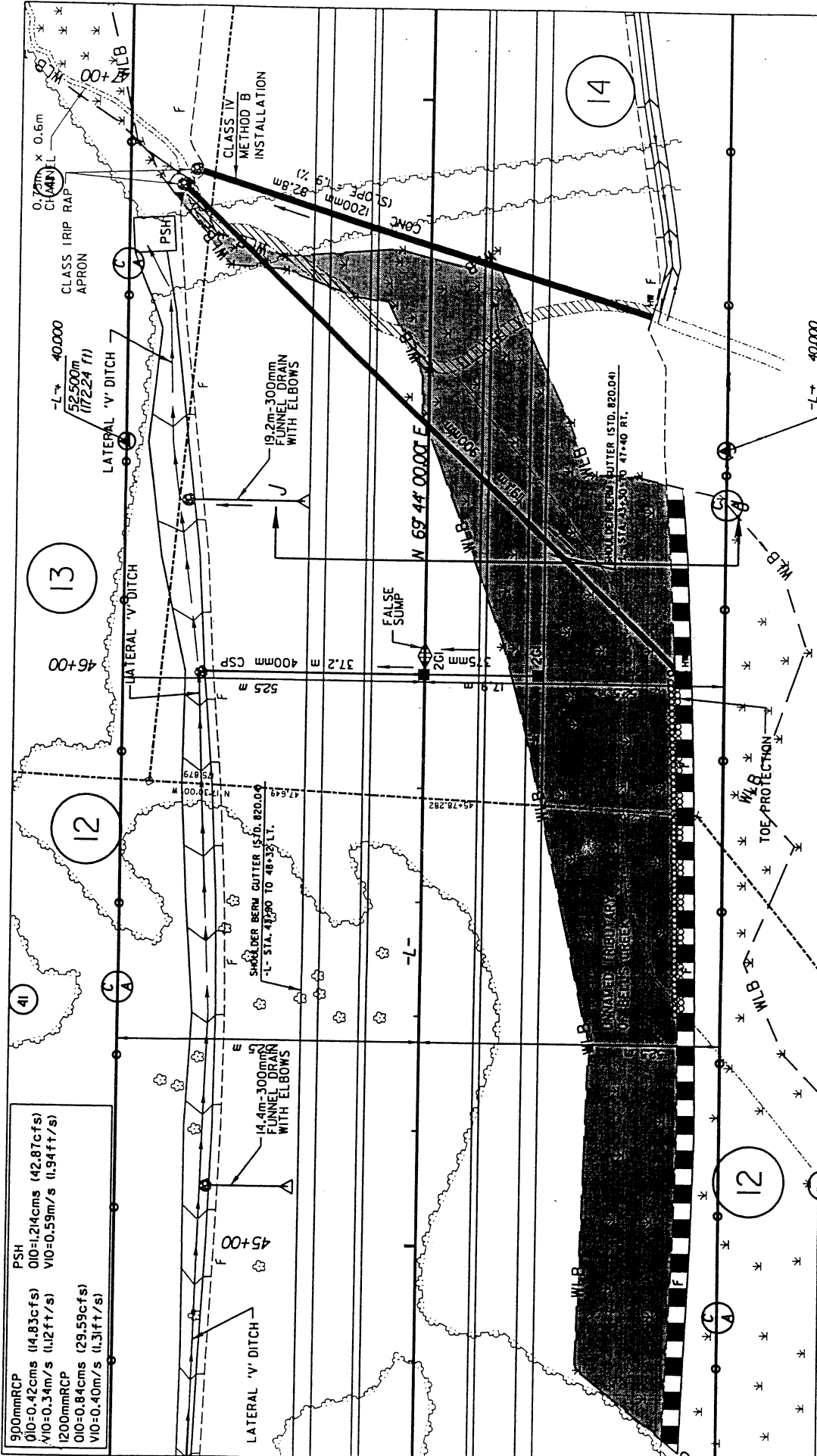

PLAN VIEW - SITE VII

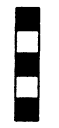
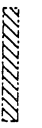
-  DENOTES FILL IN WETLANDS
-  DENOTES MECHANIZED CLEARING IN WETLANDS
-  DENOTES FILL SURFACE WATERS

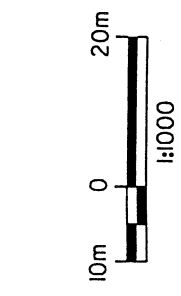

N.C. DEPT. OF TRANSPORTATION
DIVISION OF HIGHWAYS
RICHMOND COUNTY

PROJECT R-2231A

PROPOSED
US 220 FROM SOUTH OF SR 1448
TO SOUTH OF SR 1441

REV. 9-02

SHEET 22 OF 30

ELEVATIONS, METERS

144
142
140
138
136
134
132
130
128
126
124

TBM 107
RR SPIKE IN BASE OF DOUBLE
600 mm PINE 14.2 m LT OF
-L- STA 45+59.000
EL. 132.593

PIPE HYDRAULIC DATA
DRAINAGE STRUCTURE NO. 57

DRAINAGE AREA (1200 MM)	30	HA
DESIGN FREQUENCY	50	YRS
DESIGN DISCHARGE	3.33	CMS
DESIGN HW ELEVATION	128.140	M
100 YEAR DISCHARGE	3.87	CMS
100 YEAR HW ELEVATION	129.640	M
OVERTOPPING FREQUENCY	500	YRS
OVERTOPPING DISCHARGE	137.350	M

CIP 6682X

-L-

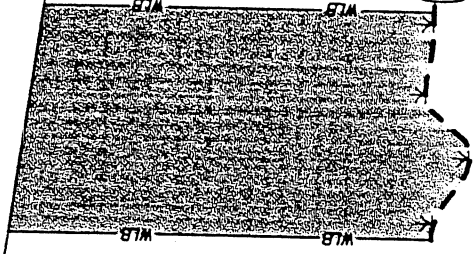

Existing Ground At -L-

45+00 .50 46+00 .50 47+00

PROFILE VIEW - SITE VII



DENOTES FILL IN WETLANDS

N.C. DEPT. OF TRANSPORTATION
DIVISION OF HIGHWAYS
RICHMOND COUNTY

PROJECT R-2231A

PROPOSED
US 220 FROM SOUTH OF SR 1448
TO SOUTH OF SR 1441

REV. 9-02

SHEET 23 OF 30

ELEVATIONS, METERS

46+20.000

-L-

140
135
130

8:1
8:1
2:1

140
135
130

EDGE OF WETLANDS

127.548

2:1

40 LT 30 LT 20 LT 10 LT 0 10 RT 20 RT 30 RT 40 RT

SECTION -J- SITE VII



DENOTES FILL IN WETLANDS

10m 0 20m

HORIZONTAL SCALE: 1:500

10m 0 20m

VERTICAL SCALE: 1:500

N.C. DEPT. OF TRANSPORTATION
DIVISION OF HIGHWAYS
RICHMOND COUNTY

PROJECT R-2231A

PROPOSED
US 220 FROM SOUTH OF SR 144B
TO SOUTH OF SR 144I

REV. 9-02

SHEET 24 OF 30

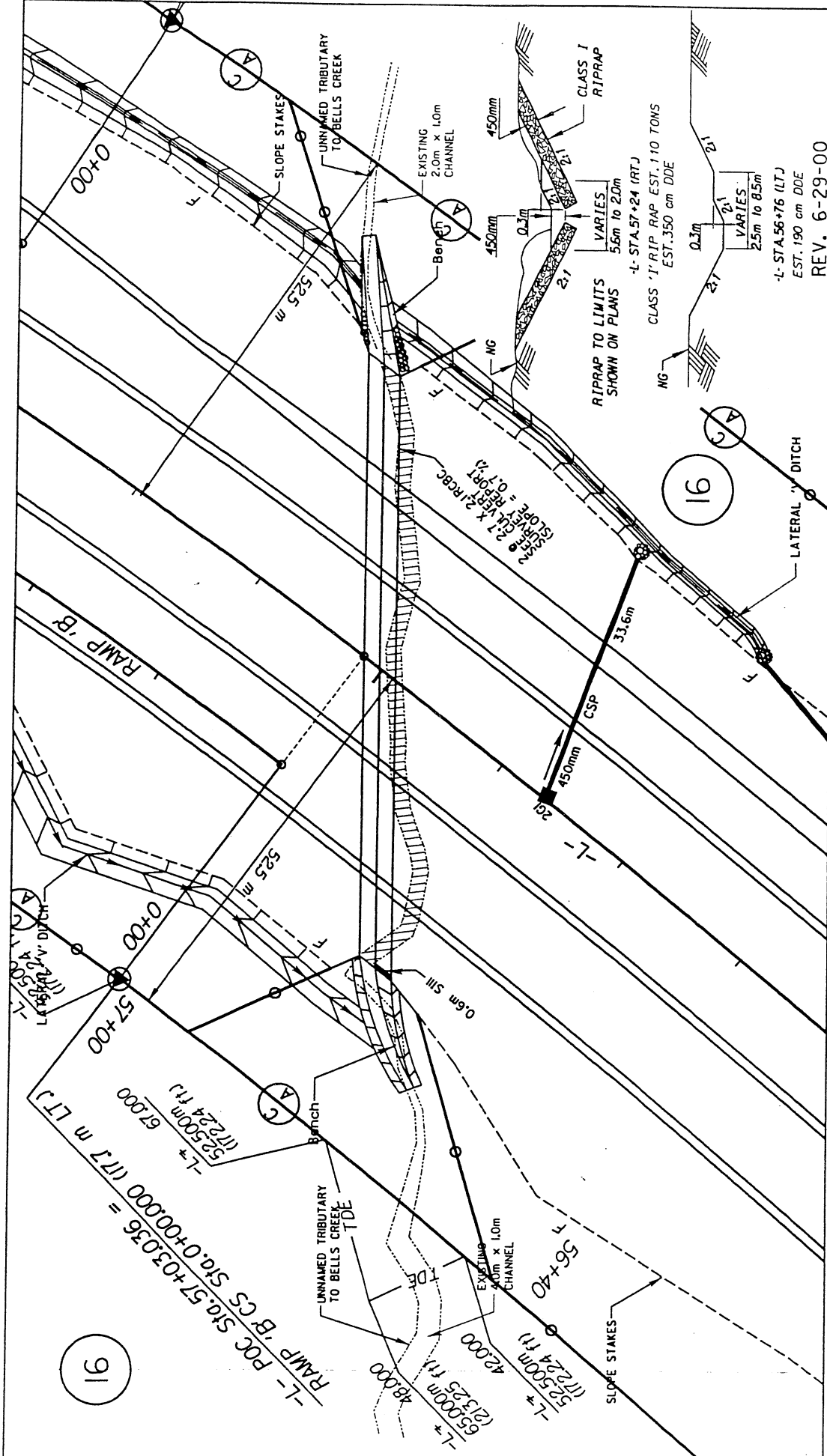

PLAN VIEW - SITE IX

N.C. DEPT. OF TRANSPORTATION
 DIVISION OF HIGHWAYS
 RICHMOND COUNTY

PROJECT R-2231A

PROPOSED
 US 220 FROM SOUTH OF SR 1448
 TO SOUTH OF SR 1441

REV. 9-02

SHEET 26 OF 30

\\\\\\\\\\\\\\\\\\\\ DENOTES FILL SURFACE WATERS

NC H&D 83

7.5m 0 15m

1:750

\\\\\\\\\\\\\\\\\\\\

PARCEL NO.	PROPERTY OWNER NAME	PROPERTY OWNER ADDRESS
①	EMMA & ROLYN ELLERBE	RT 4 BOX 295 WADESBORO, N.C. 28170
②	JOSEPH G. JR. & BETTY DAVIS	915 MORNINGSIDE DR. ROCKINGHAM, N.C. 28379
③	ROBERT LEE & BRENDA KAY THORSBY	PO BOX 212 ELLERBE, N.C. 28338
④	MELVIN G ELLINGER	5341 SW 9TH PLACE CAPE CORAL, FL. 33914
⑤	DUNCAN H & CHARLOTTE Q GRANT	1836 N. US. HWY 220 ELLERBE, N.C. 28338
⑥	NEAL HAYWOOD GRANT	1836 N. US. HWY 220 ELLERBE, N.C. 28338
⑦	JANICE L. BROWN	PO BOX 604 ELLERBE, N.C. 28338
⑧	BOBBY ANN NICHOLSON TERRY	PO BOX 352 ELLERBE, N.C. 28338
⑨ & ⑩	JUANITA ASKEW	1230 SQUIRREL HILL RD. CHARLOTTE, N.C. 28213
⑪	HAROLD JEROME NICHOLSON	PO BOX 152 ELLERBE, N.C. 28338
⑫	WALTER RAY & EMMA STANCIL	127 STANCIL DR. ELLERBE, N.C. 28338
⑬	SANDY THOMAS LEAK	PO BOX 355 ELLERBE, N.C. 28338
⑭	ANTHONY A & BRENDA CAPEL	PO BOX 462 ELLERBE, N.C. 28338
⑮	JORDAN LUMBER & SUPPLY CO.	P.O. BOX 98 MT. GILEAD, N.C. 27306
⑯	ROGER H ALLRED SR	6726 LANGER DR. CHARLOTTE, N.C. 28226

N.C. DEPT. OF TRANSPORTATION
DIVISION OF HIGHWAYS
RICHMOND COUNTY

PROJECT R-2231A

PROPOSED
US 220 FROM SOUTH OF SR 1448
TO SOUTH OF SR 1441

REV. 9-02

SHEET 28 OF 30

WETLAND PERMIT IMPACT SUMMARY

Site No.	Station (From/To)	Structure Size / Type	WETLAND IMPACTS				SURFACE WATER IMPACTS				Natural Stream Design (m)		
			Fill In Wetlands (ha)	Temp. Fill In Wetlands (ha)	Excavation In Wetlands (ha)	Mechanized Clearing (Method III) (ha)	Fill In SW (Natural) (ha)	Fill In SW (Pond) (ha)	Temp. Fill In SW (ha)	Existing Channel Impacted (m)			
I	16+58.9 -L-		0.155			0.022							
IIA	19+00 -L-		0.924										
IIB	21+08.7 -L-		0.528		0.004	0.038		0.038				192.16	
IIC	22+80 -L-				0.065	0.004							
III	27+00 -L-		0.225		0.658	0.051		0.015				61.92	
IV	30+44.5 -L-		0.608			0.064		0.019				97.52	
V	34+58.9 -L-		0.173			0.02							
VI	38+56.2 -L-		0.717			0.067							
VII	46+75 -L-		0.469			0.05		0.018				71.2	
VIII	52+31.4 -L-		0.103			0.011		0.016				93.88	
IX	57+00 -L-	2 @ 2.7m x 2.1m RCBC						0.016				80.84	
X	65+72 -L-							0.023				114.08	
TOTALS:			3.902	0	0.727	0.327	0.145	0	0	0	0	711.60	0

NCDOT

DIVISION OF HIGHWAYS
 RICHMOND COUNTY
 PROJECT: R-2231A
 US 220 BYPASS SOUTH OF SR 1448
 TO SOUTH OF SR 1441

10/16/02

SHEET 29 OF 30

WETLAND PERMIT IMPACT SUMMARY

Site No.	Station (From/To)	Structure Size / Type	WETLAND IMPACTS					SURFACE WATER IMPACTS						
			Fill In Wetlands (ac)	Temp. Fill In Wetlands (ac)	Excavation In Wetlands (ac)	Mechanized Clearing (Method III) (ac)	Fill In SW (Natural) (ac)	Fill In SW (Pond) (ac)	Temp. Fill In SW (ac)	Existing Channel Impacted (ft)	Natural Stream Design (ft)			
I	16+58.9 -L-		0.38			0.05								
IIA	19+00 -L-		2.28											
IIB	21+08.7 -L-		1.30		0.01	0.09	0.09						630.4	
IIC	22+80 -L-				0.16	0.01								
III	27+00 -L-		0.56		1.63	0.13	0.04						203.1	
IV	30+44.5 -L-		1.50			0.16	0.05						319.9	
V	34+58.9 -L-		0.43			0.05								
VI	38+56.2 -L-		1.77			0.17								
VII	46+75 -L-		1.16			0.12	0.04						233.5	
VIII	52+31.4 -L-		0.25			0.03	0.04						308.0	
IX	57+00 -L-	2 @ 9' x 8' RCBC					0.04						265.2	
X	65+72 -L-						0.06						374.3	
TOTALS:			9.63	0	1.80	0.81	0.36	0	0	0	0	2334.4	0	

NC DEPARTMENT OF TRANSPORTATION
 DIVISION OF HIGHWAYS
 RICHMOND COUNTY
 PROJECT: R-2231A
 US 220 BYPASS
 10/16/02 SHEET 30 OF 30

WETLAND LEGEND

— WLB — WETLAND BOUNDARY

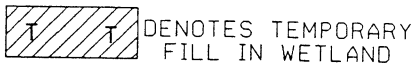
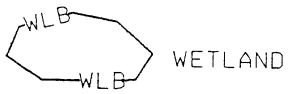

— FLOW DIRECTION

TB — TOP OF BANK

WE — EDGE OF WATER

C — PROP. LIMIT OF CUT

F — PROP. LIMIT OF FILL

▲ — PROP. RIGHT OF WAY

NG — NATURAL GROUND

PL — PROPERTY LINE

TDE — TEMP. DRAINAGE EASEMENT

PDE — PERMANENT DRAINAGE EASEMENT

EAB — EXIST. ENDANGERED ANIMAL BOUNDARY

EPB — EXIST. ENDANGERED PLANT BOUNDARY

▽ — WATER SURFACE

x x x x
x x x x
LIVE STAKES

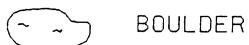

— CORE FIBER ROLLS

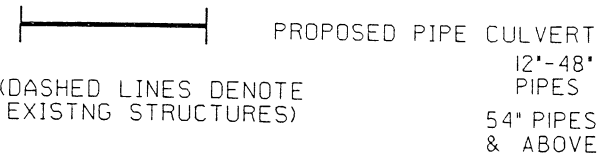

(DASHED LINES DENOTE EXISTING STRUCTURES)

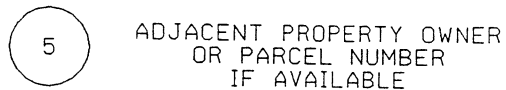
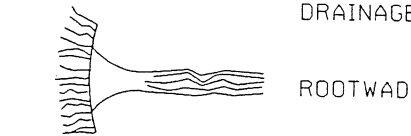

N. C. DEPT. OF TRANSPORTATION
DIVISION OF HIGHWAYS
RICHMOND COUNTY

PROJECT: 8.T550802 (R-2251B)

US 220 BYPASS

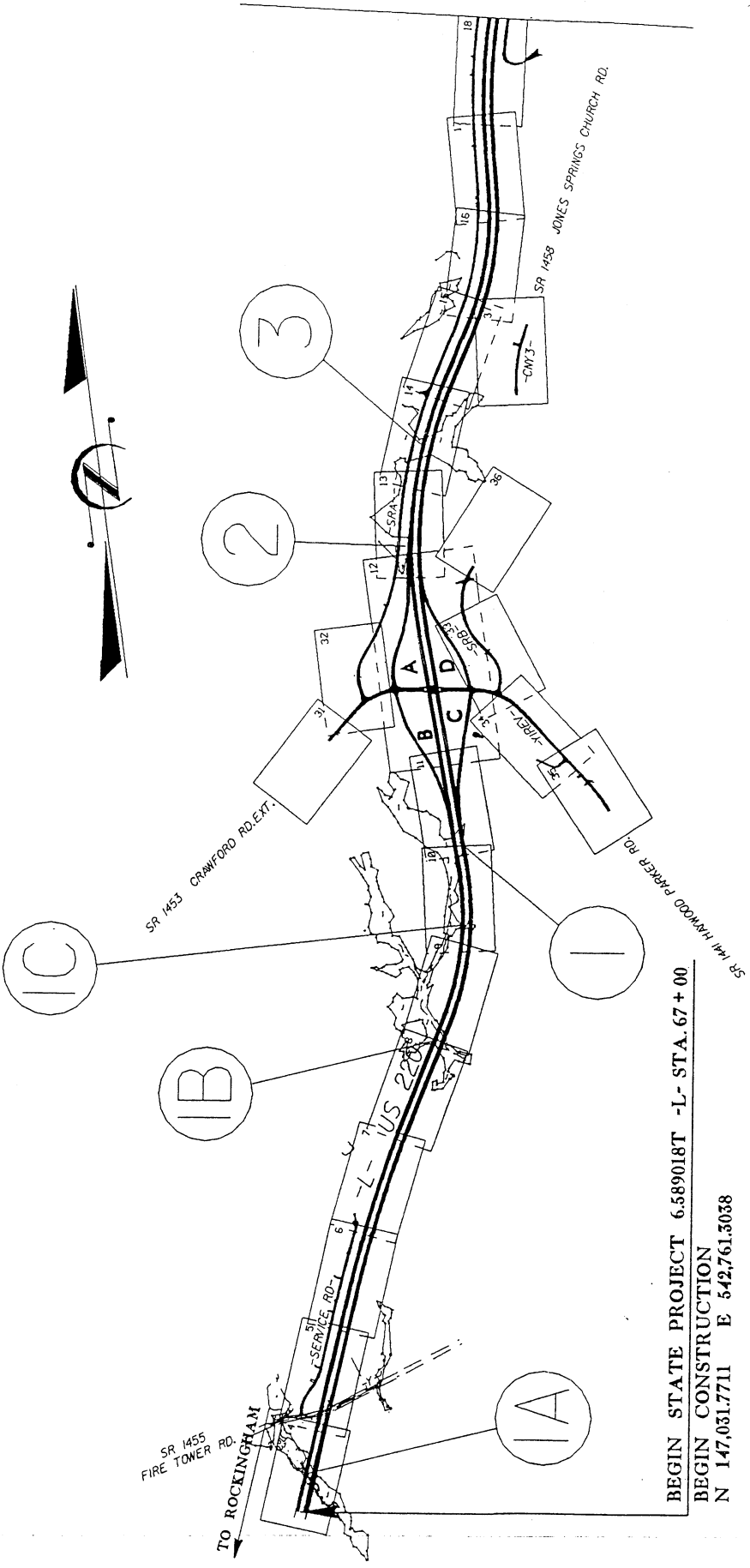

BEGIN STATE PROJECT 6.589018T -L- STA. 67 + 00
 BEGIN CONSTRUCTION
 N 147,031.7711 E 542,761.3038

N. C. DEPT. OF TRANSPORTATION
 DIVISION OF HIGHWAYS
 RICHMOND COUNTY
 PROJECT: 8.T550802 (R-2231B)
 US 220 BYPASS

VICINITY MAP

DETAIL OF RIP-RAPPED DITCH ENERGY DISSIPATOR BASIN

STATE OF NORTH CAROLINA
DIVISION OF HIGHWAYS
RALEIGH, N.C.

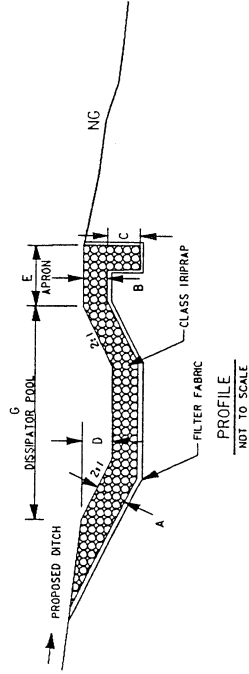

NOT ALL RIP RAP SHOWN

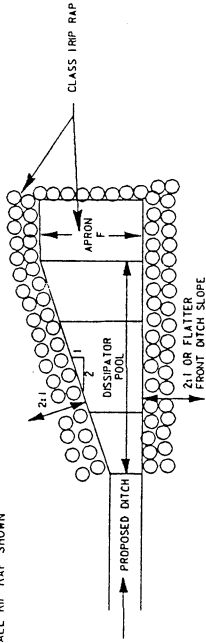

PLAN VIEW
NOT TO SCALE

BASIN #	LOCATION
1	Sta 67+54 To 67+71 -L- (RT)
2	Sta 68+28 To 68+45 -L- (LT)
3	Sta 68+41 To 68+69 -L- (RT)
4	Sta 85+16 To 85+31 -L- (LT)
5	Sta 86+35 To 86+50 -L- (LT)
6	Sta 28+20 To 28+37 -L- (RT)

DIM. (m)	RIP RAP BASIN #					
	1	2	3	4	5	6
A	0.60	0.60	0.60	0.60	0.60	0.60
B	0.60	0.60	0.60	0.60	0.60	0.60
C	0.60	0.60	0.60	0.60	0.60	0.60
D	0.60	0.60	0.60	0.60	0.60	0.60
E	3.0	3.0	3.0	3.0	3.0	3.0
F	6.0	6.0	6.0	6.0	6.0	6.0
G	12.0	12.0	12.0	12.0	12.0	12.0

ALL DIMENSIONS APPROXIMATE

N. C. DEPT. OF TRANSPORTATION
DIVISION OF HIGHWAYS
RICHMOND COUNTY
PROJECT: 8.T550802 (R-2231B)

US 220 BYPASS

9/02

SHEET 5 OF 43

CL SECTION

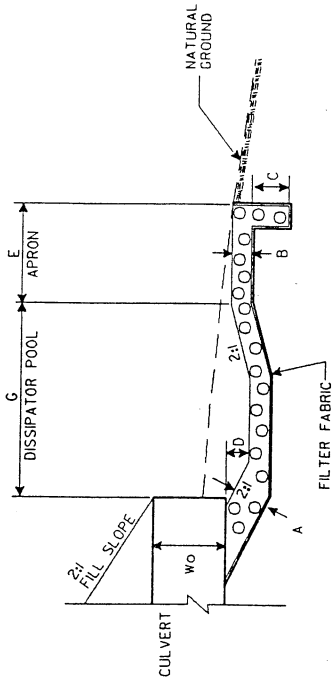

DIM.	1	2	3
RIP RAP BASIN #			
A	0.60	0.60	0.60
B	0.60	0.60	0.60
C	0.60	0.60	0.60
D	0.60	0.60	0.60
E	3.0	3.0	3.0
F	8.4	8.4	8.4
G	6.0	6.0	6.0

ALL DIMENSIONS APPROXIMATE

HALF PLAN

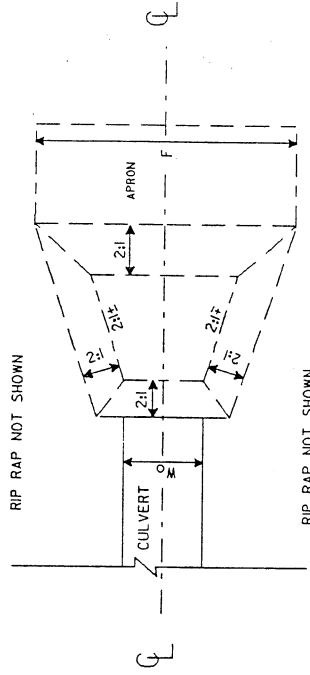

BASIN #	LOCATION (AT OUTLET)
1	Sta 90+80 -L- (L+)
2	Sta 93+80 -L- (L+)
3	Sta 108+04 -L- (R+)

DETAIL OF RIP-RAPPED OUTLET ENERGY DISSIPATOR BASIN

STATE OF NORTH CAROLINA
DIVISION OF HIGHWAYS
RALEIGH, N.C.

N. C. DEPT. OF TRANSPORTATION
DIVISION OF HIGHWAYS
RICHMOND COUNTY
PROJECT: 8.T550802 (R-2231B)

US 220 BYPASS

PREFORMED SCOUR HOLE

PLAN VIEW

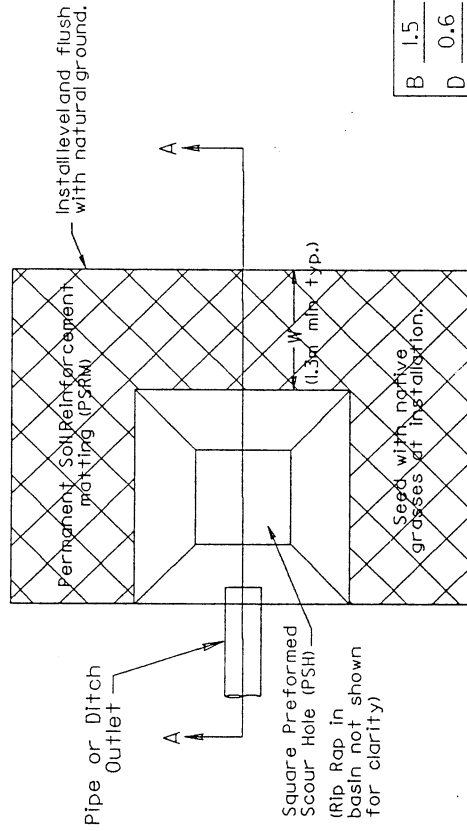

B	1.5
D	0.6
W	2.0
d	0.15

SECTION A-A

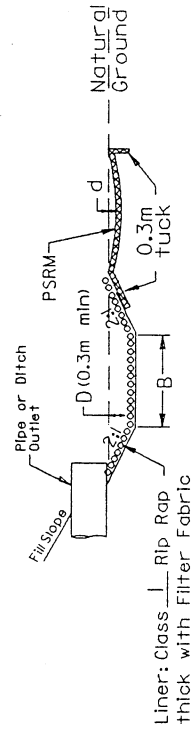

BASIN #	LOCATION (AT OUTLET)
1	Sta 69+34 -L- (Rt)
2	Sta 85+00 -L- (Rt)
3	Sta 85+73 -L- (Rt)
4	Sta 15+81 -SRA- (Lt)
5	Sta 16+67 -SRA- (Lt)
6	Sta 22+78 -Y4REV- (Rt)
7	Sta 141+00 -L- (Lt)

N. C. DEPT. OF TRANSPORTATION
 DIVISION OF HIGHWAYS
 RICHMOND COUNTY
 PROJECT: 8.T550802 (R-2231B)

US 220 BYPASS

9/02

SHEET 7 OF 43

PERMANENT BERM
(Not to Scale)

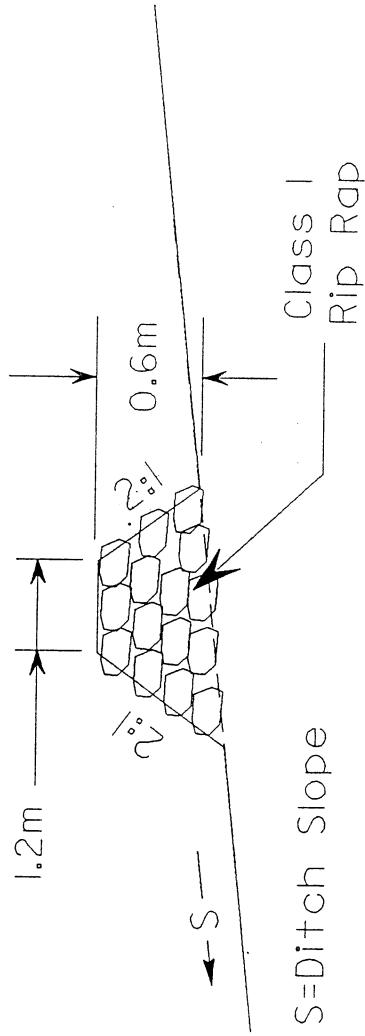

N. C. DEPT. OF TRANSPORTATION
DIVISION OF HIGHWAYS
RICHMOND COUNTY

PROJECT: 8.T550802 (R-2231B)

US 220 BYPASS

7/02

SHEET 8 OF 43

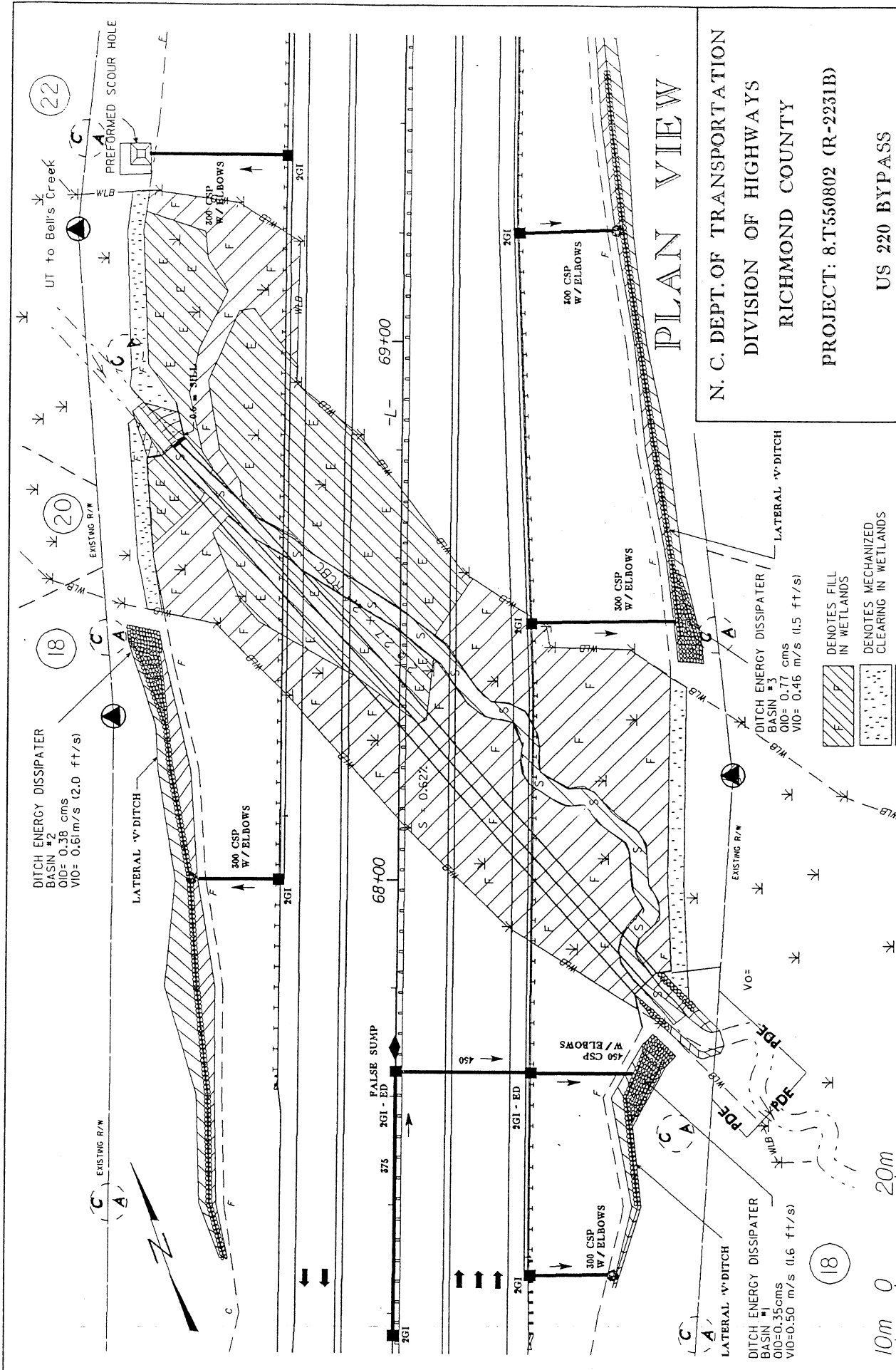

DITCH ENERGY DISSIPATER
 BASIN #2
 O10= 0.38 cms
 V10= 0.61m/s (2.0 ft/s)

DITCH ENERGY DISSIPATER
 BASIN #1
 O10= 0.35cms
 V10= 0.50 m/s (1.6 ft/s)

DITCH ENERGY DISSIPATER
 BASIN #3
 O10= 0.77 cms
 V10= 0.46 m/s (1.5 ft/s)

- DENOTES FILL IN WETLANDS
- DENOTES MECHANIZED CLEARING IN WETLANDS
- DENOTES FILL IN SURFACE WATERS
- DENOTES EXCAVATION IN WETLANDS

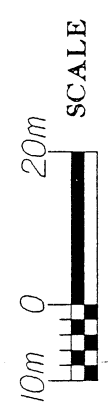

SITE 1A

PLAN VIEW

N. C. DEPT. OF TRANSPORTATION
 DIVISION OF HIGHWAYS
 RICHMOND COUNTY
 PROJECT: 8.T550802 (R-2231B)

US 220 BYPASS

Typical Section 68+40 -L-

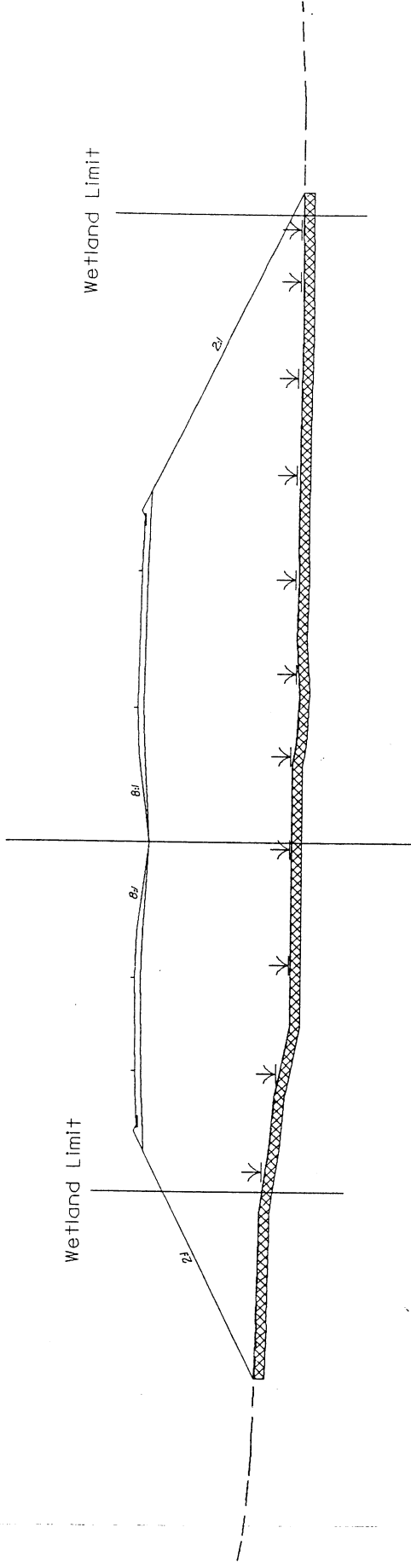

SECTION



HORIZONTAL SCALE



VERTICAL SCALE

N. C. DEPT. OF TRANSPORTATION
DIVISION OF HIGHWAYS
RICHMOND COUNTY
PROJECT: 8.T550802 (R-2231B)

US 220 BYPASS

SHEET 10 OF 43

9/02

PROPOSED GRADE

+3.0000%

-0.5419%

WETLAND LIMIT

END CULVERT
-L- STA 68+37.88

NATURAL GROUND

WETLAND LIMIT

2 @ 2.7m X 2.4m RCBC
BEGIN CULVERT
-L- STA 68+28.812

68

69

PROFILE

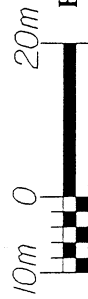

N. C. DEPT. OF TRANSPORTATION
 DIVISION OF HIGHWAYS
 RICHMOND COUNTY
 PROJECT: 8.T550802 (R-2231B)

US 220 BYPASS

SHEET 11 OF 43

9/02

124

120

116

112

108

Elevation (E)

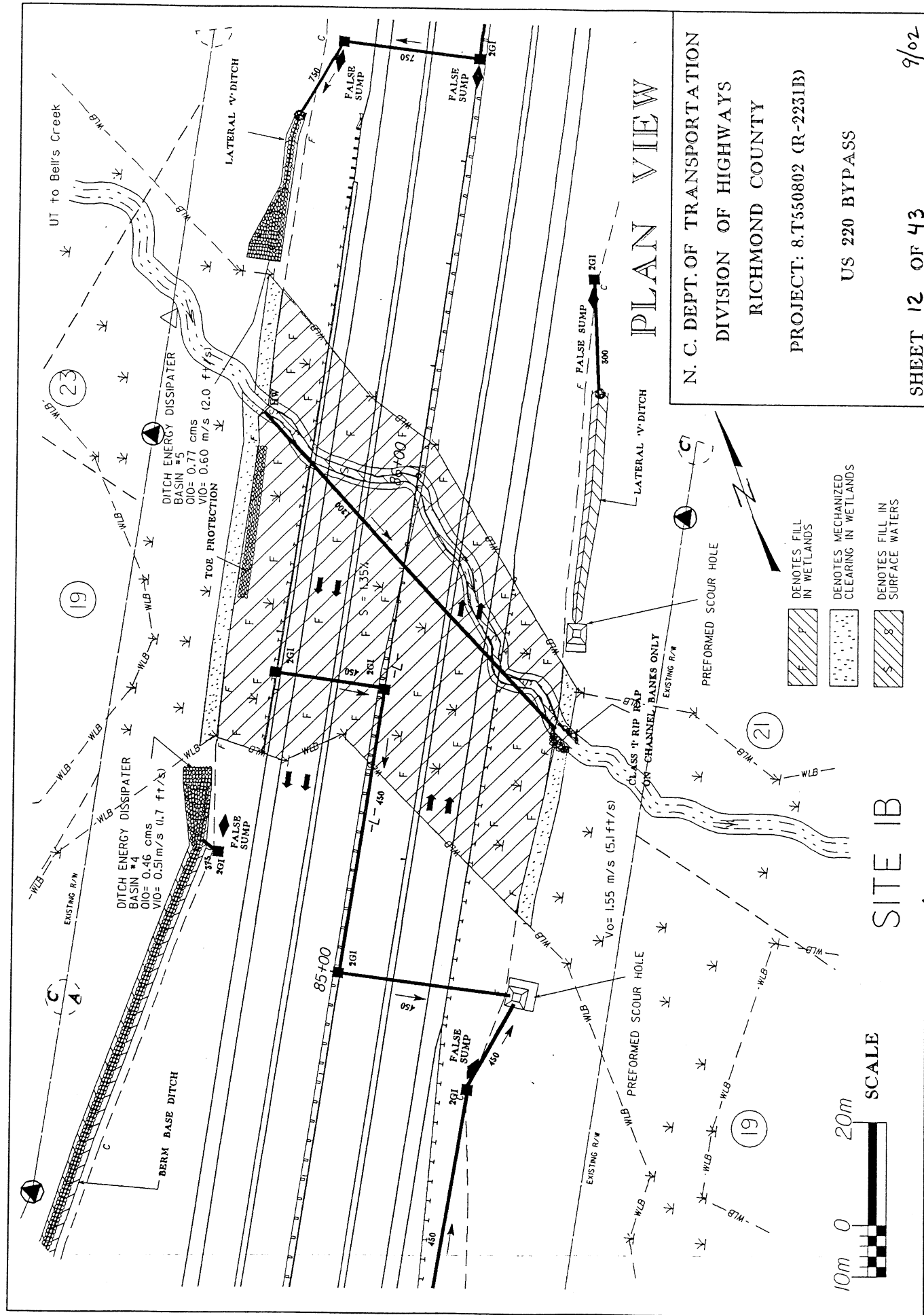

Typical Section
85+60 -L-

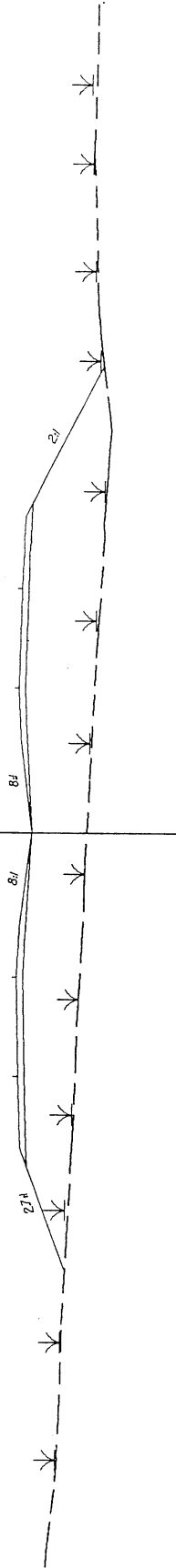

SECTION



HORIZONTAL SCALE

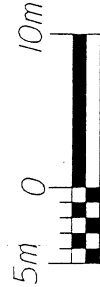

VERTICAL SCALE

N. C. DEPT. OF TRANSPORTATION
DIVISION OF HIGHWAYS
RICHMOND COUNTY
PROJECT: 8.T550802 (R-2231B)

US 220 BYPASS

SHEET 13 OF 43

9/02

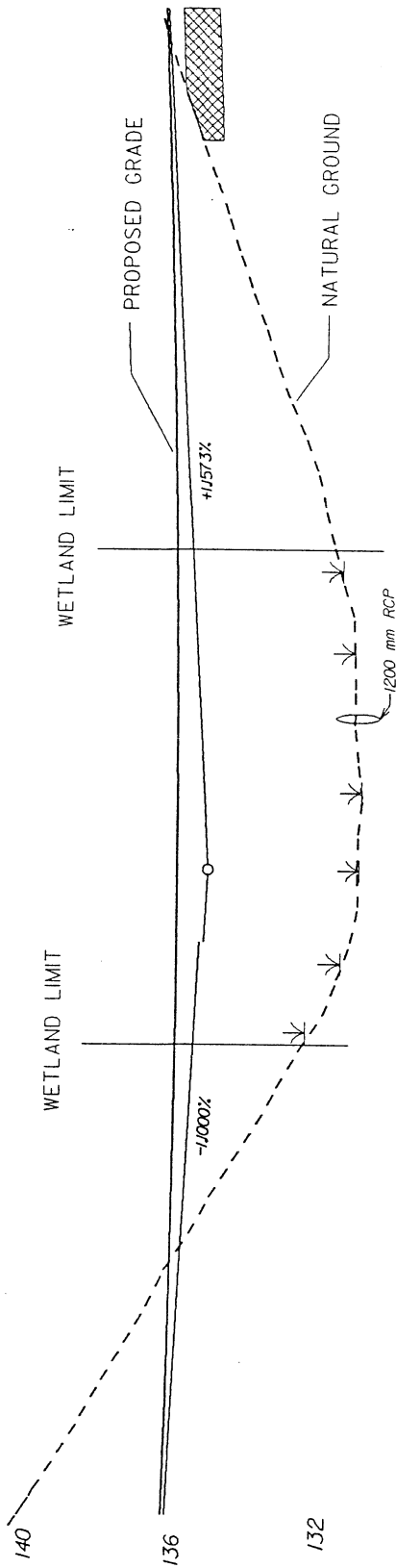

Elevation (m)

86

-LREV-

85

N. C. DEPT. OF TRANSPORTATION
 DIVISION OF HIGHWAYS
 RICHMOND COUNTY
 PROJECT: 8.T550802 (R-2231B)
 US 220 BYPASS

SHEET 14 OF 43 9/02

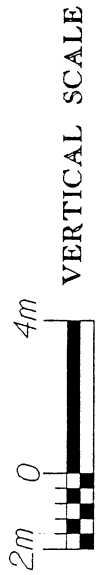

PROFILE

Matchline

PLAN VIEW

N. C. DEPT. OF TRANSPORTATION

DIVISION OF HIGHWAYS

RICHMOND COUNTY

PROJECT: 8.T550802 (R-2231B)

US 220 BYPASS

SHEET 15 OF 43

9/02

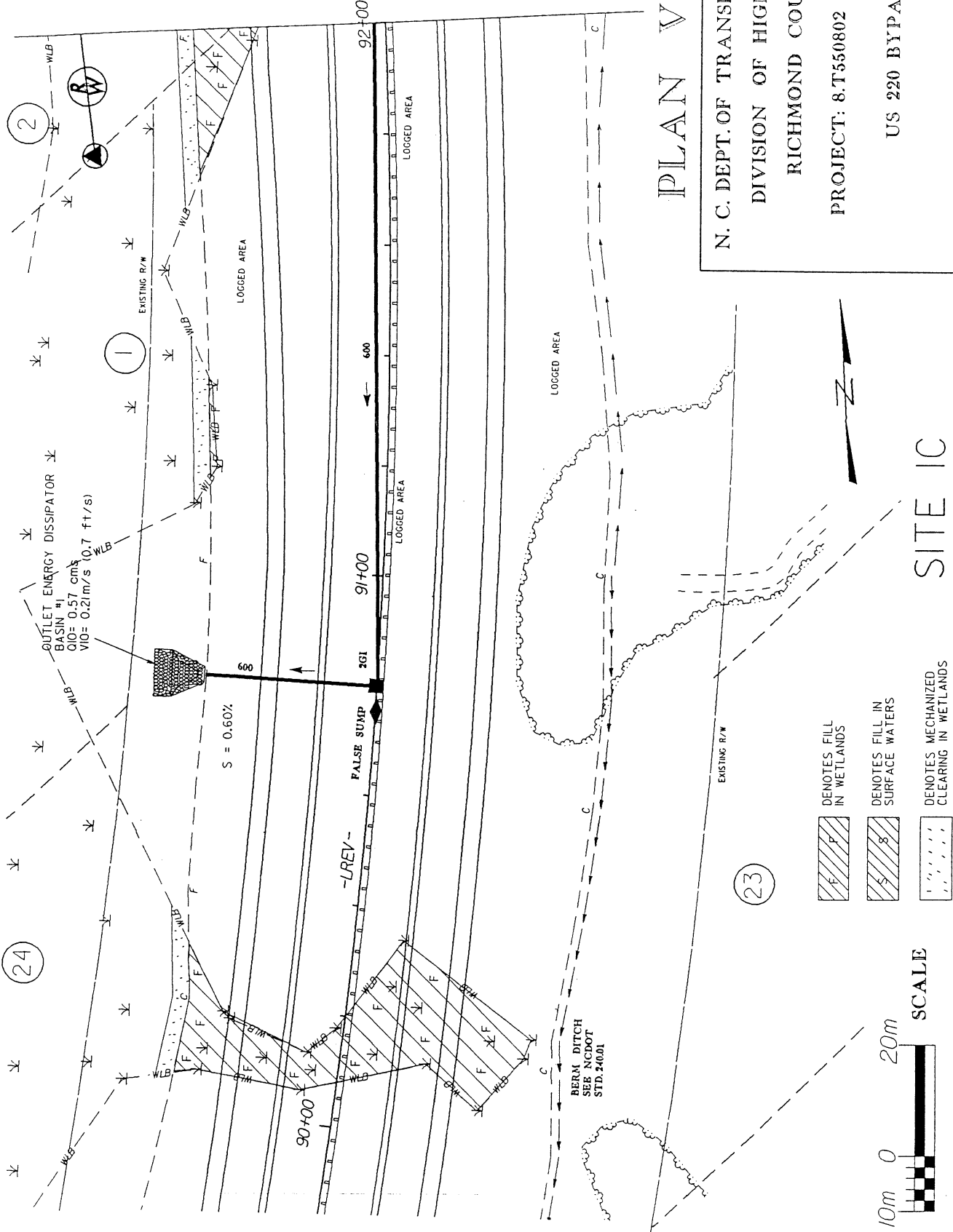

SITE IC

SCALE

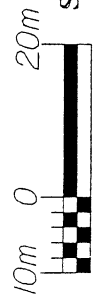

- DENOTES FILL IN WETLANDS
- DENOTES FILL IN SURFACE WATERS
- DENOTES MECHANIZED CLEARING IN WETLANDS

23

24

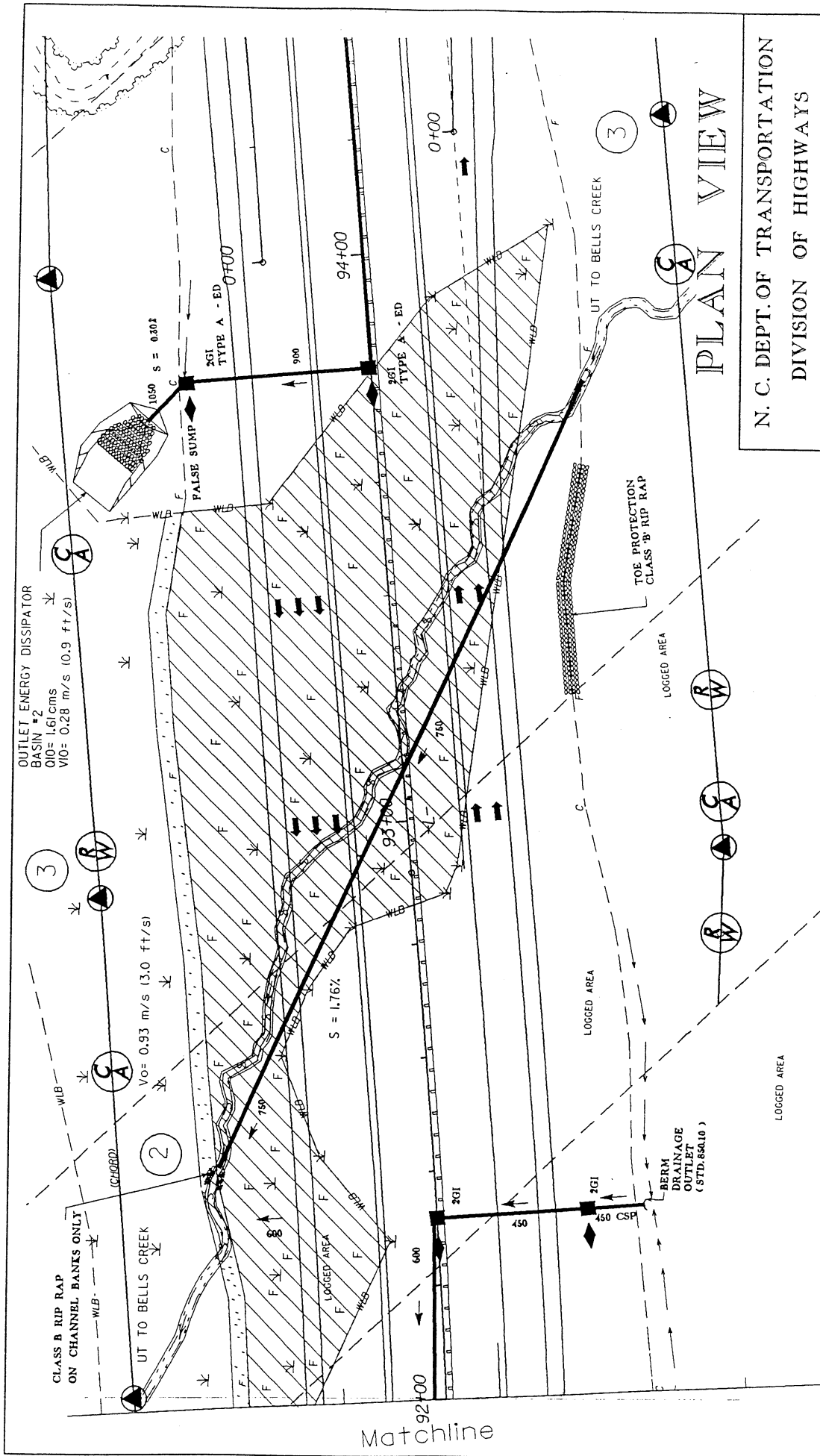

PLAN VIEW

N. C. DEPT. OF TRANSPORTATION
 DIVISION OF HIGHWAYS
 RICHMOND COUNTY
 PROJECT: 8.T550802 (R-2231B)
 US 220 FROM SOUTH OF SR 1448
 TO SOUTH OF SR 1441
 SHEET 16 OF 43
 9/02

- DENOTES FILL IN WETLANDS
- DENOTES FILL IN SURFACE WATERS
- DENOTES MECHANIZED CLEARING IN WETLANDS

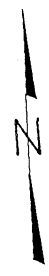

SITE 1

69

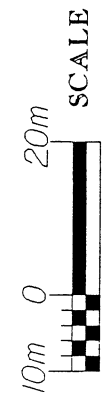

Typical Section 92+80 -L-

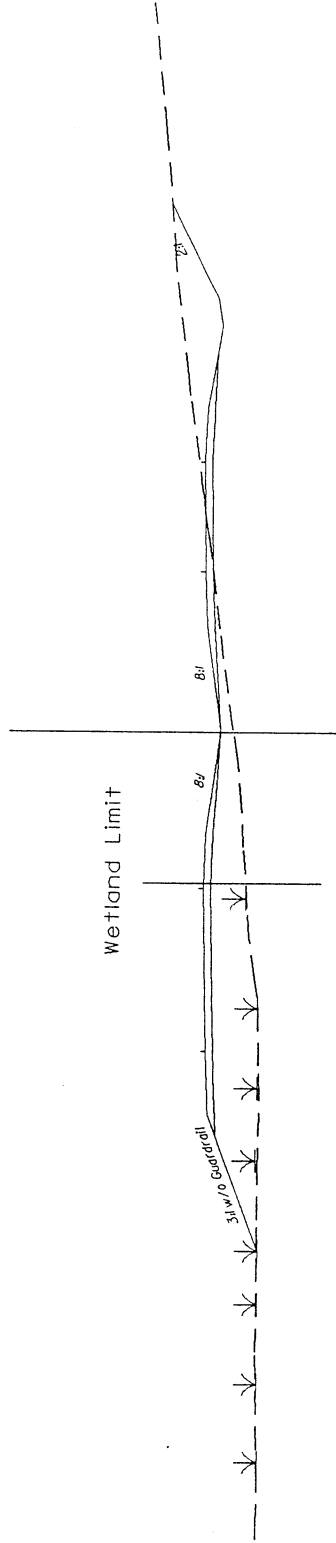

SECTION

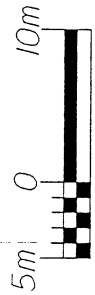

HORIZONTAL SCALE

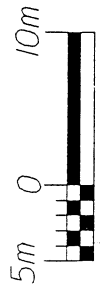

VERTICAL SCALE

N. C. DEPT. OF TRANSPORTATION
DIVISION OF HIGHWAYS
RICHMOND COUNTY
PROJECT: 8.T550803 (R-2231B)

US 220 BYPASS

SHEET 17 OF 43

9/02

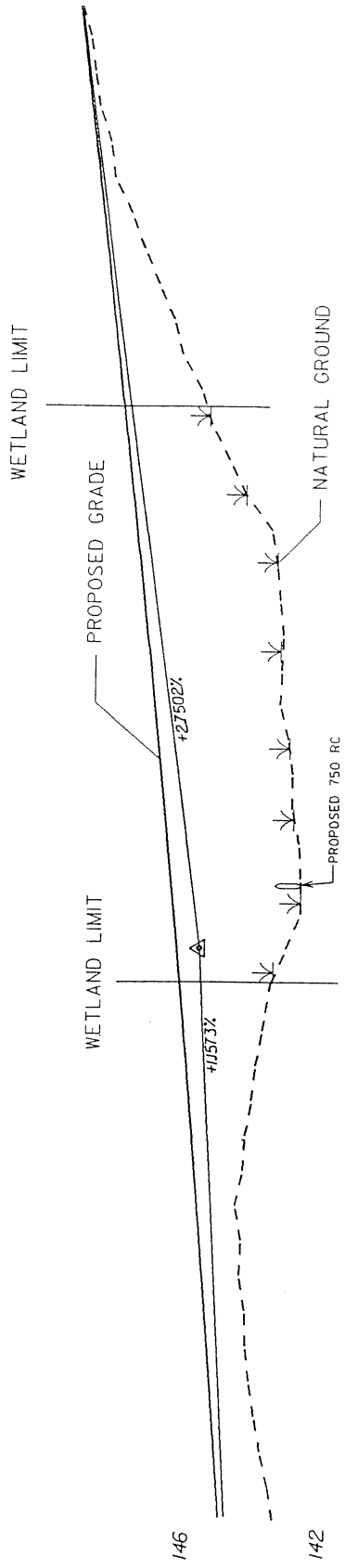

Elevation (m)

94

93

--L--

PROFILE

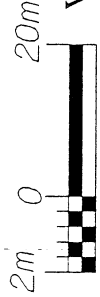

N. C. DEPT. OF TRANSPORTATION
 DIVISION OF HIGHWAYS
 RICHMOND COUNTY
 PROJECT: 8.T550802 (R-2231B)
 US 220 BYPASS

DENOTES FILL
IN WETLANDS

DENOTES MECHANIZED
CLEARING IN WETLANDS

PREPARED SCOUR HOLE

VO = 1.23 m/s (4.0 ft/s)

PREPARED SCOUR HOLE

PLAN VIEW

N. C. DEPT. OF TRANSPORTATION
DIVISION OF HIGHWAYS
RICHMOND COUNTY
PROJECT: 8.T550802 (R-2231B)

US 220 BYPASS

SHEET 19 OF 43 9/02

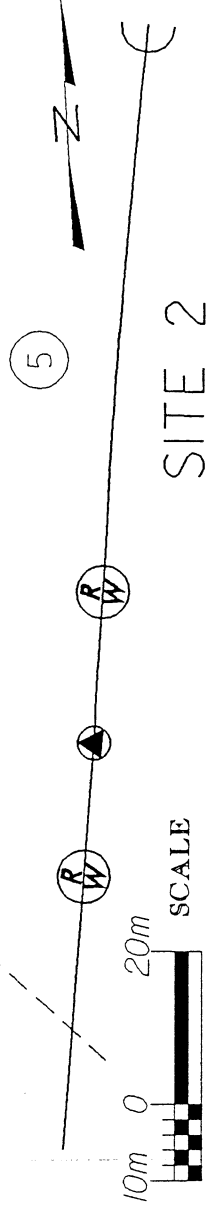
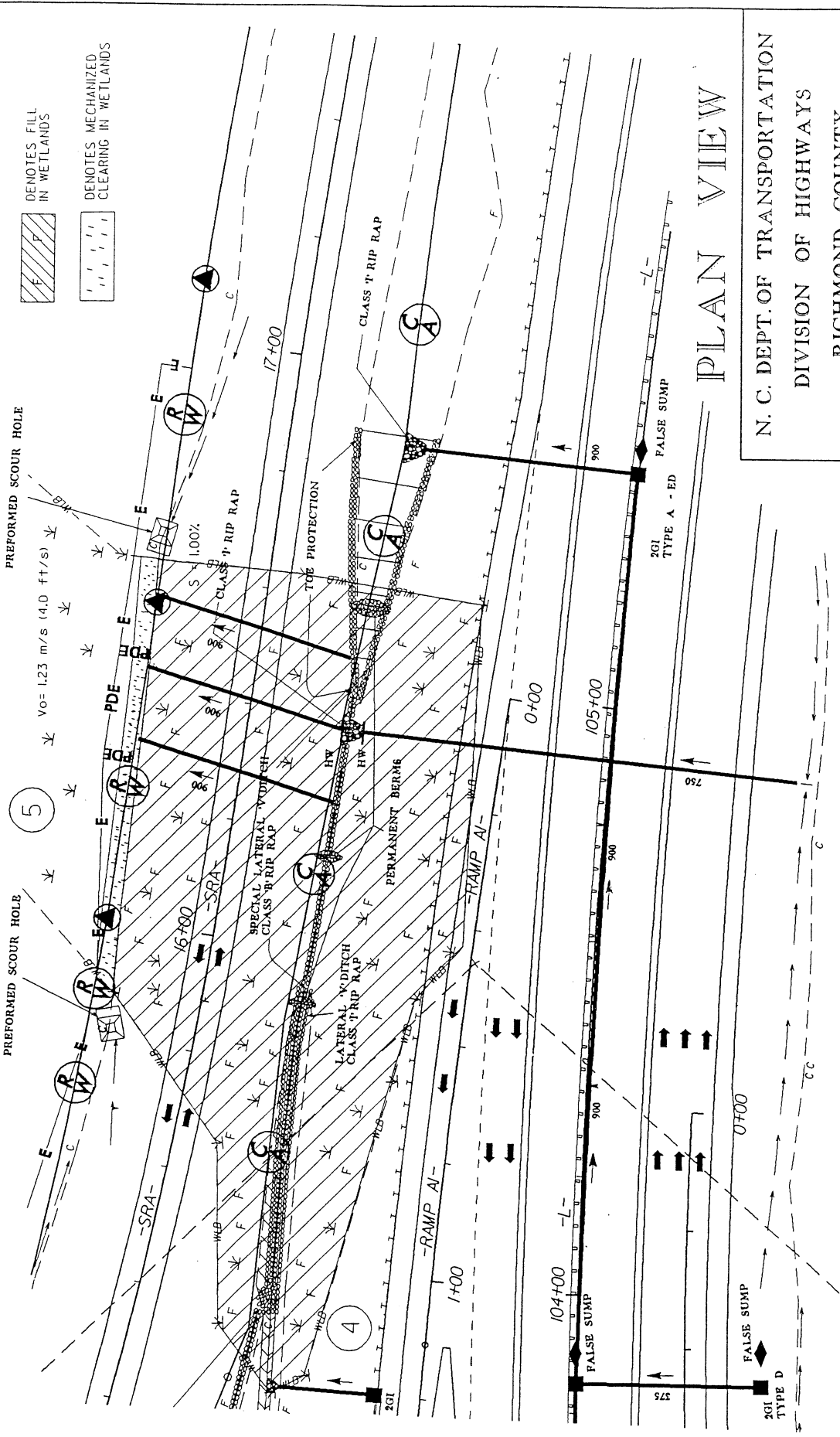

SITE 2

SCALE

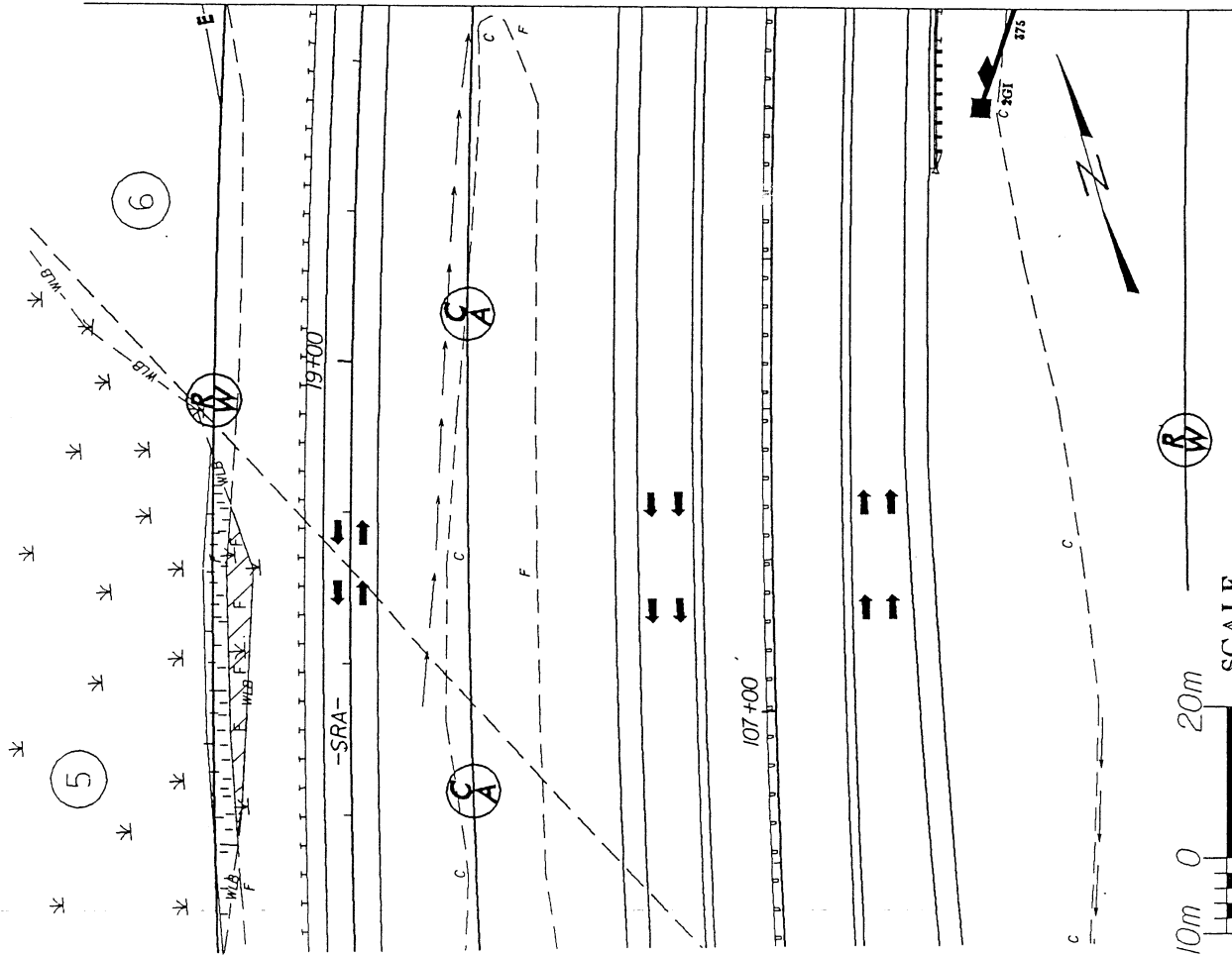

PLAN VIEW

N. C. DEPT. OF TRANSPORTATION
 DIVISION OF HIGHWAYS
 RICHMOND COUNTY
 PROJECT: 8.T550802 (R-2231B)

US 220 BYPASS

SITE 3

Typical Section 105+00 -L-

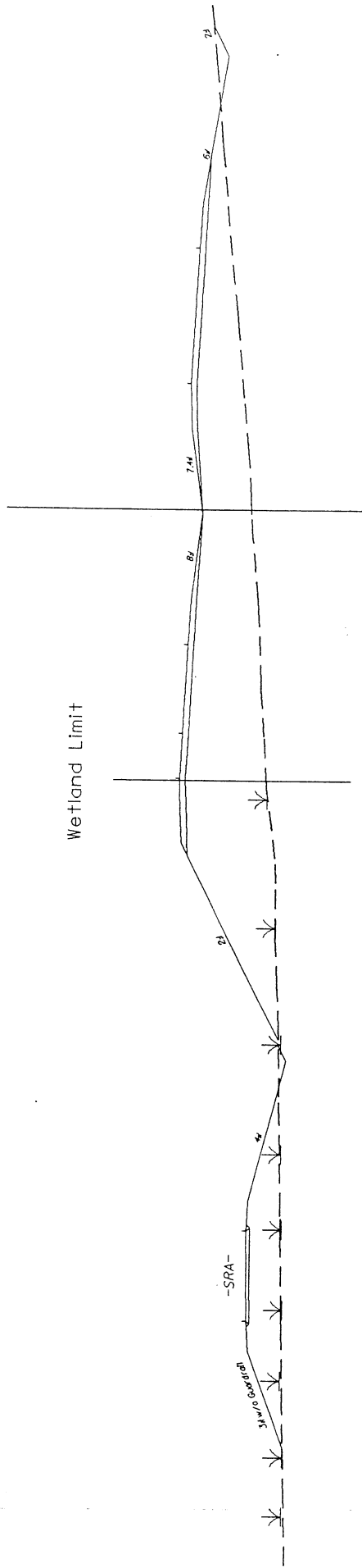

SECTION



HORIZONTAL SCALE

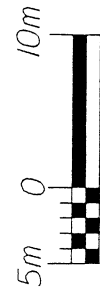

VERTICAL SCALE

N. C. DEPT. OF TRANSPORTATION
DIVISION OF HIGHWAYS
RICHMOND COUNTY
PROJECT: 8.T550803 (R-2231B)

US 220 BYPASS

SHEET 21 OF 43

9/02

WETLAND LIMIT

154

150

WETLAND LIMIT

+1.927%

+0.5824%

146

142

Elevation (m)

PROPOSED 900 RC



16

17

-SRA-

PROFILE



HORIZONTAL SCALE



VERTICAL SCALE

N. C. DEPT. OF TRANSPORTATION
 DIVISION OF HIGHWAYS
 RICHMOND COUNTY
 PROJECT: 8.T550802 (R-2231B)
 US 220 FROM SOUTH OF SR 1448
 TO SOUTH OF SR 1441

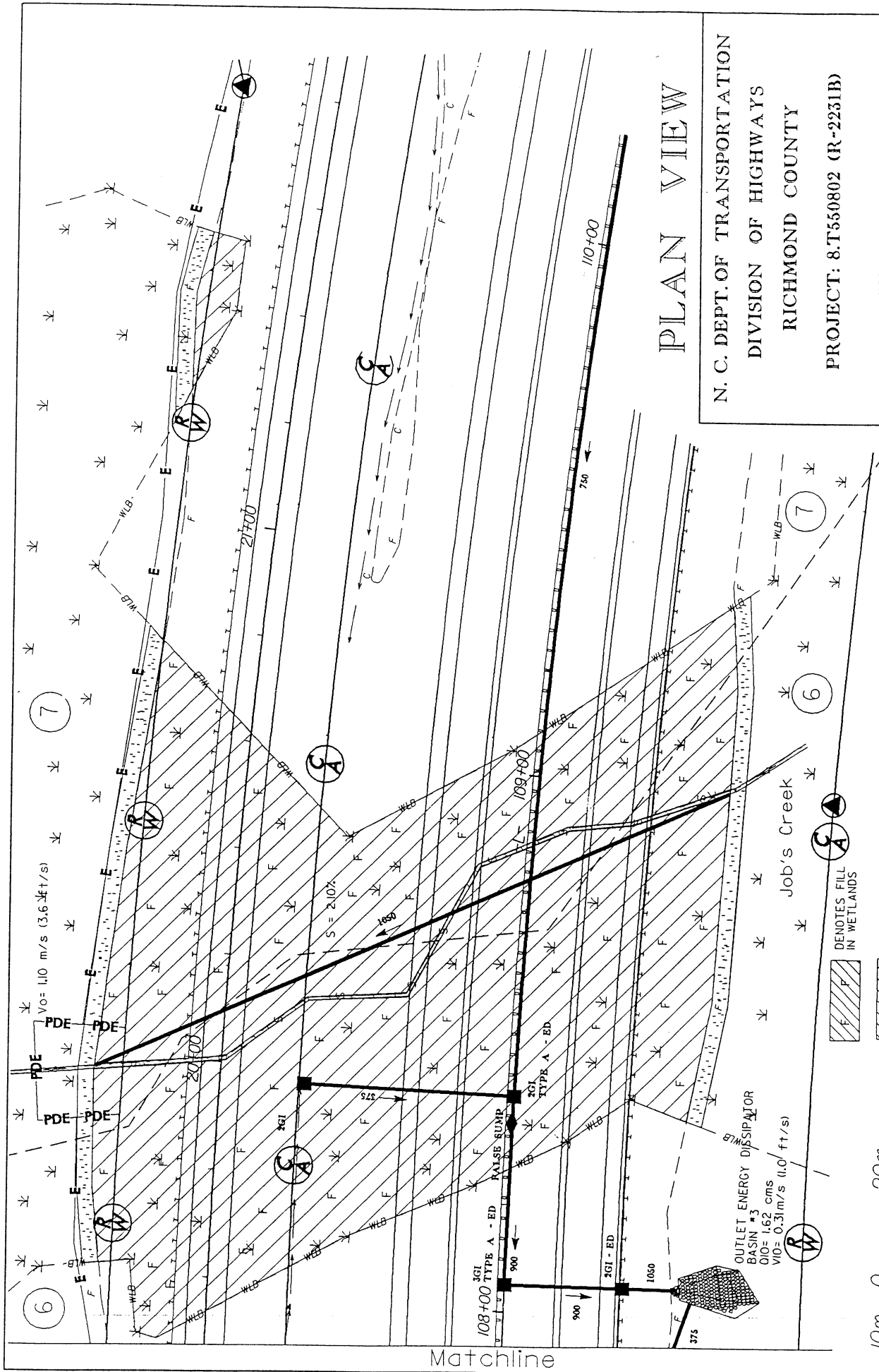

Matchline

PLAN VIEW



N. C. DEPT. OF TRANSPORTATION
 DIVISION OF HIGHWAYS
 RICHMOND COUNTY

PROJECT: 8.T550802 (R-2231B)

US 220 BYPASS

SITE 3

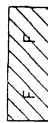
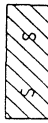

-  DENOTES FILL IN WETLANDS
-  DENOTES FILL IN SURFACE WATERS
-  DENOTES MECHANIZED CLEARING IN WETLANDS

Typical Section 108+40 -L-

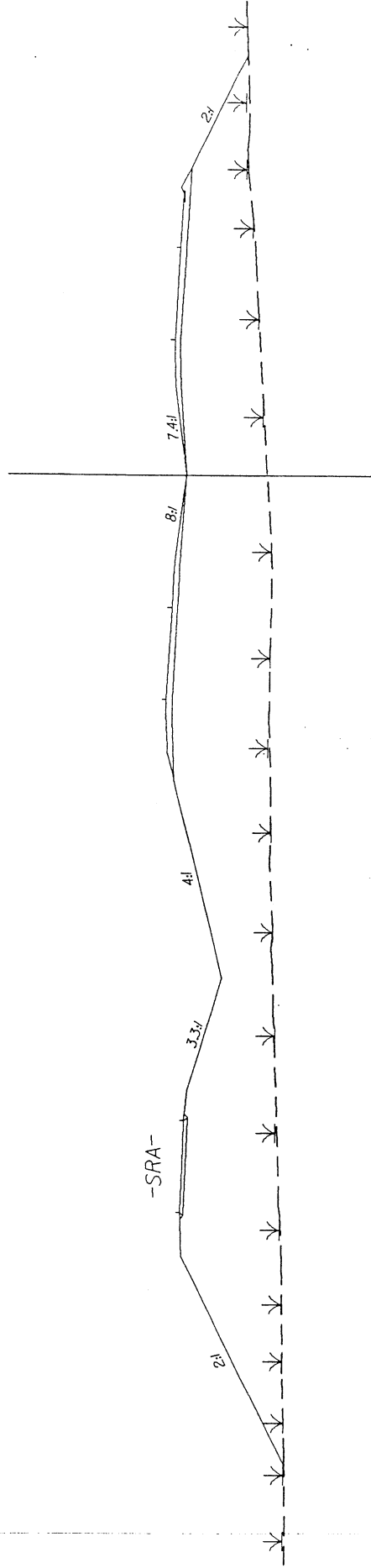

SECTION



HORIZONTAL SCALE



VERTICAL SCALE

N. C. DEPT. OF TRANSPORTATION

DIVISION OF HIGHWAYS

RICHMOND COUNTY

PROJECT: 8.T550803 (R-2231B)

US 220 BYPASS

SHEET 24 OF 43

9/02

WETLAND LIMIT

WETLAND LIMIT

156

152

148

144

Elevation (m)

PROPOSED GRADE

(-)0.861%

(+)1.5903%

NATURAL GROUND

PROPOSED 1050 RC

108

109

PROFILE



HORIZONTAL SCALE



VERTICAL SCALE

N. C. DEPT. OF TRANSPORTATION

DIVISION OF HIGHWAYS

RICHMOND COUNTY

PROJECT: 8.T550802 (R-2231B)

US 220 BYPASS

SHEET 25 OF 43

9/02

Denotes Impact to Pond

Denotes Fill in Wetlands

Denotes Mechanized Clearing in Wetlands

Matchline

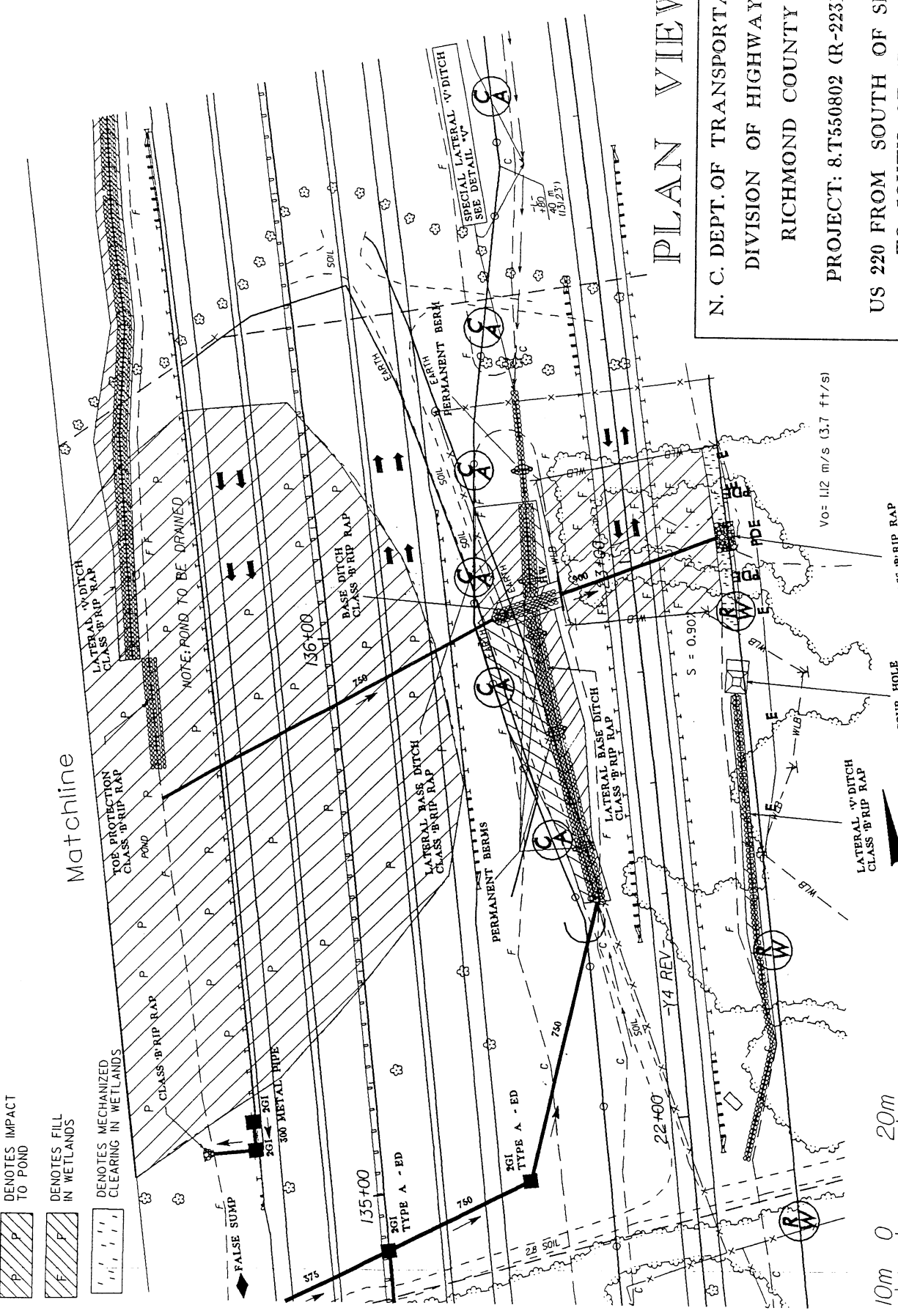

PLAN VIEW

N. C. DEPT. OF TRANSPORTATION
 DIVISION OF HIGHWAYS
 RICHMOND COUNTY
 PROJECT: 8.T550802 (R-2231B)
 US 220 FROM SOUTH OF SR 1448
 TO SOUTH OF SR 1441

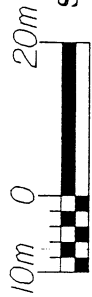

SCALE

PREFORMED SCOUR HOLE CLASS 'B' RIP RAP

NAD 83

SITES 4 & 5

SHEET 26 OF 43

9/02

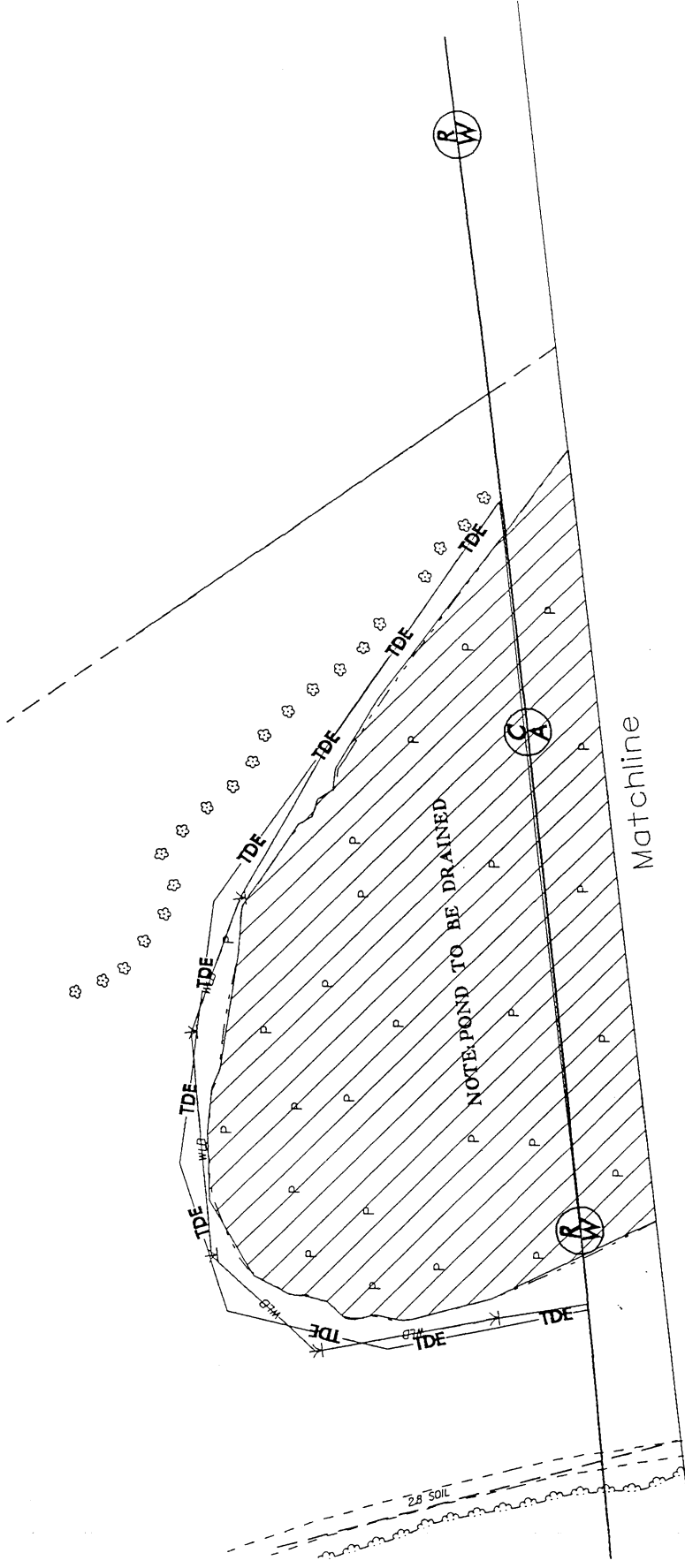

PLAN VIEW

N. C. DEPT. OF TRANSPORTATION
 DIVISION OF HIGHWAYS
 RICHMOND COUNTY

PROJECT: 8.T550802 (R-2231B)

US 220 FROM SOUTH OF SR 1448
 TO SOUTH OF SR 1441

SHEET 27 OF 43

9/02

SITE 5

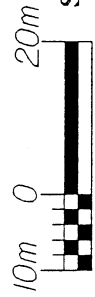

SCALE

 DENOTES IMPACT
 TO POND

MATCHLINE

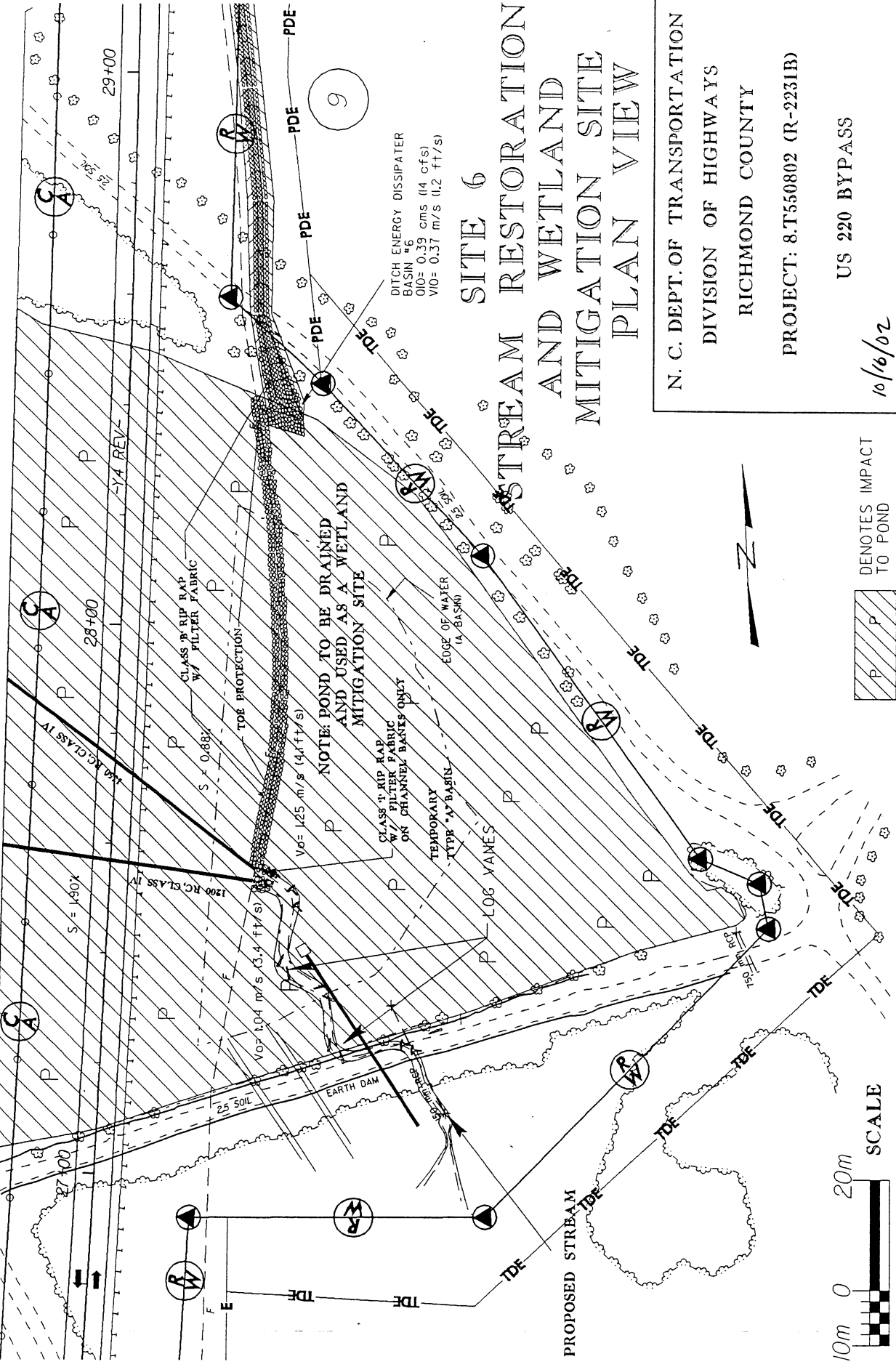

NOTE: POND TO BE DRAINED
AND USED AS A WETLAND
MITIGATION SITE

DITCH ENERGY DISSIPATER
BASIN #6
O10= 0.39 cms (14 cfs)
V10= 0.37 m/s (1.2 ft/s)

SITE 6 STREAM RESTORATION AND WETLAND MITIGATION SITE PLAN VIEW

N. C. DEPT. OF TRANSPORTATION
DIVISION OF HIGHWAYS
RICHMOND COUNTY
PROJECT: 8.T550802 (R-2231B)

US 220 BYPASS

10/16/02

SHEET 28 OF 43

■ DENOTES IMPACT
TO POND

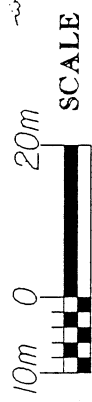

DENOTES IMPACT TO POND

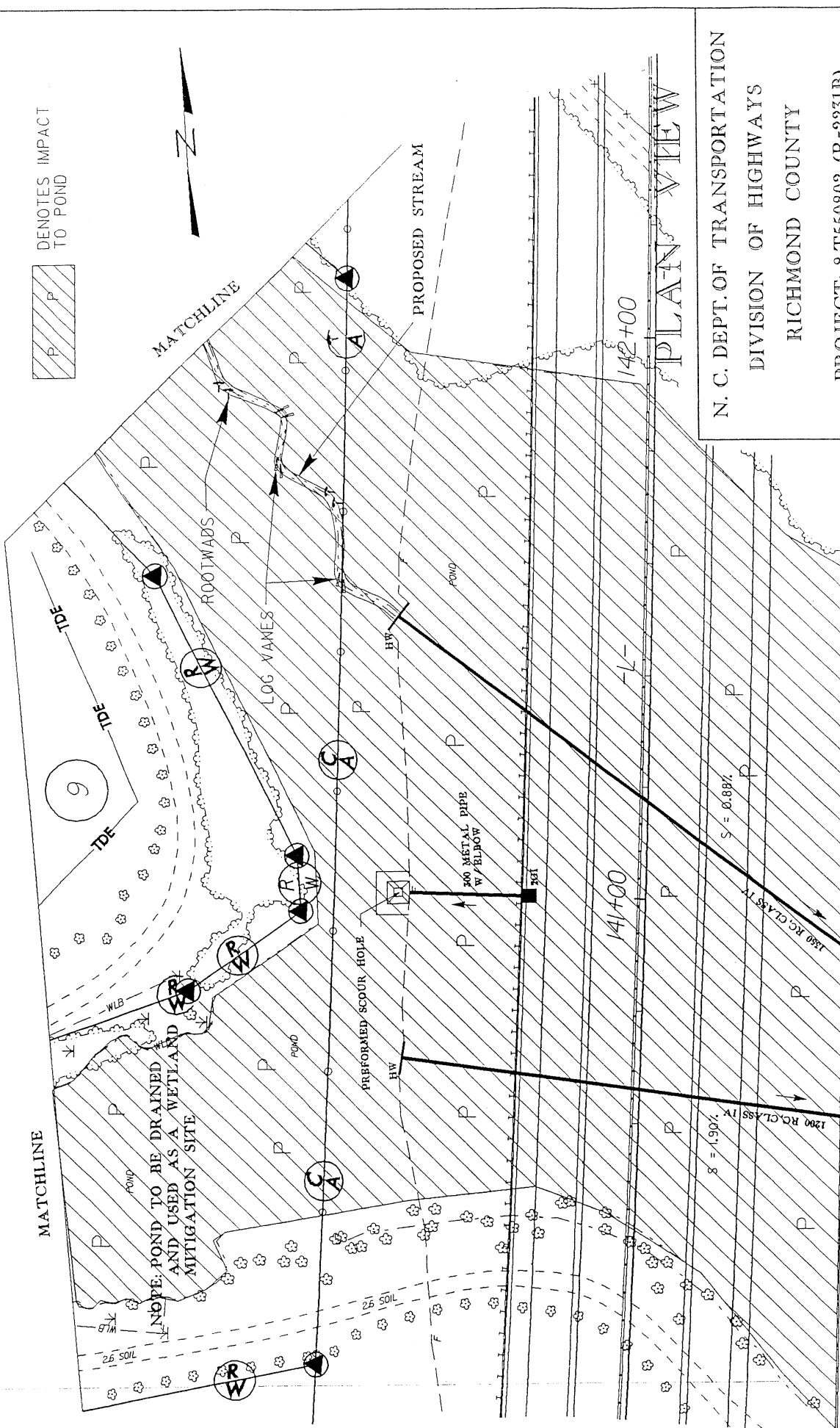
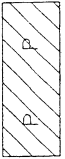

MATCHLINE

MATCHLINE

PROPOSED STREAM

PLAIN VIEW

NOTE: POND TO BE DRAINED AND USED AS A WETLAND MITIGATION SITE.

SITE 6 STREAM RESTORATION AND WETLAND MITIGATION SITE

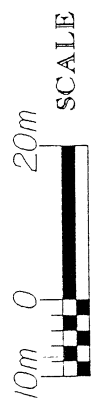

SCALE

N. C. DEPT. OF TRANSPORTATION
DIVISION OF HIGHWAYS
RICHMOND COUNTY
PROJECT: 8.T550802 (R-2231B)

US 220 BYPASS

10/16/02

SHEET 29 OF 43

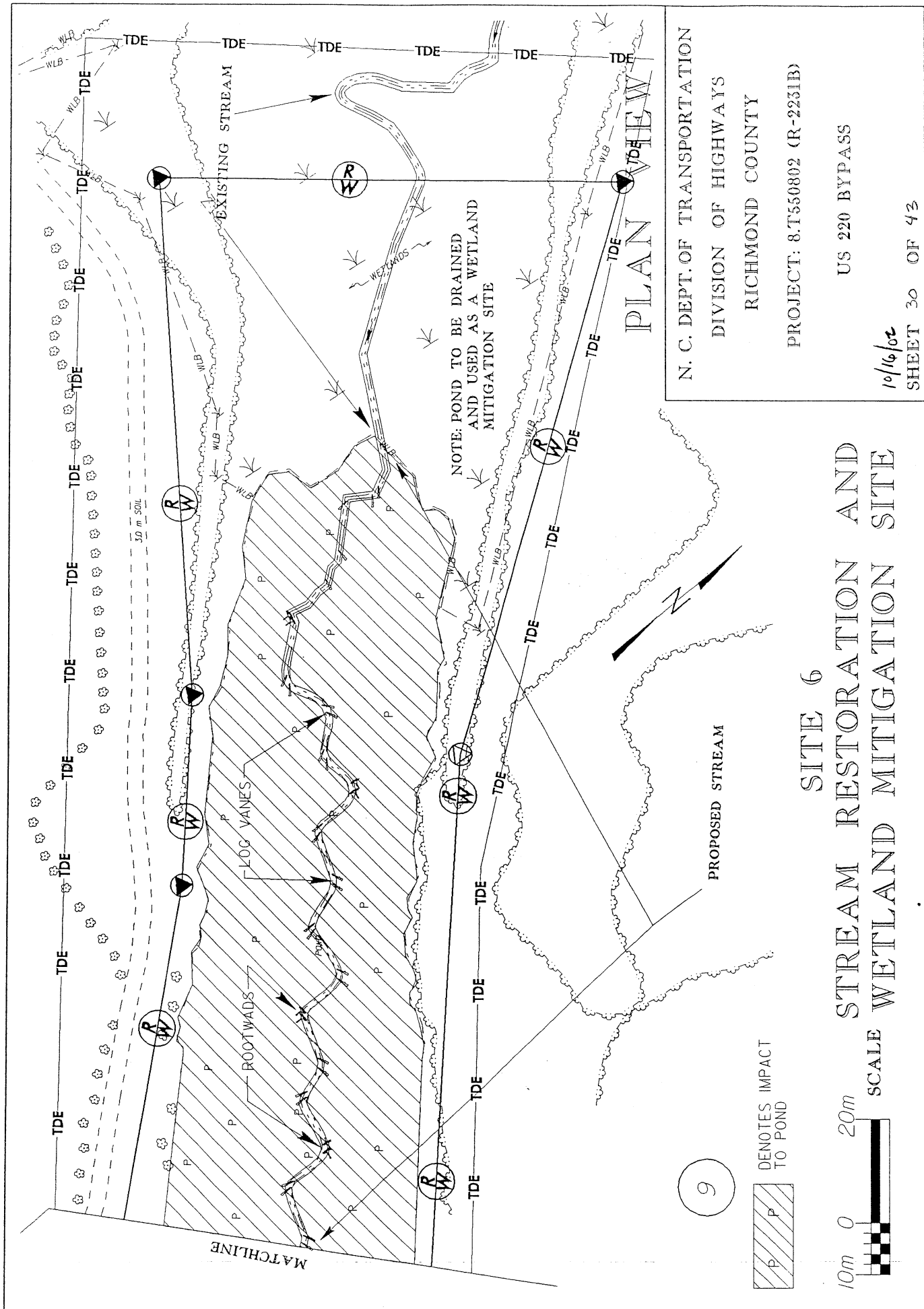

N. C. DEPT. OF TRANSPORTATION
 DIVISION OF HIGHWAYS
 RICHMOND COUNTY
 PROJECT: 8.T550802 (R-2231B)

US 220 BYPASS

10/16/02

SHEET 30 OF 43

SITE 6
 STREAM RESTORATION AND
 WETLAND MITIGATION SITE

9

10m 0 20m
 DENOTES IMPACT TO POND

PROPOSED STREAM

NOTE: POND TO BE DRAINED
 AND USED AS A WETLAND
 MITIGATION SITE

PLAN VIEW

MATCHLINE

30 m SOIL

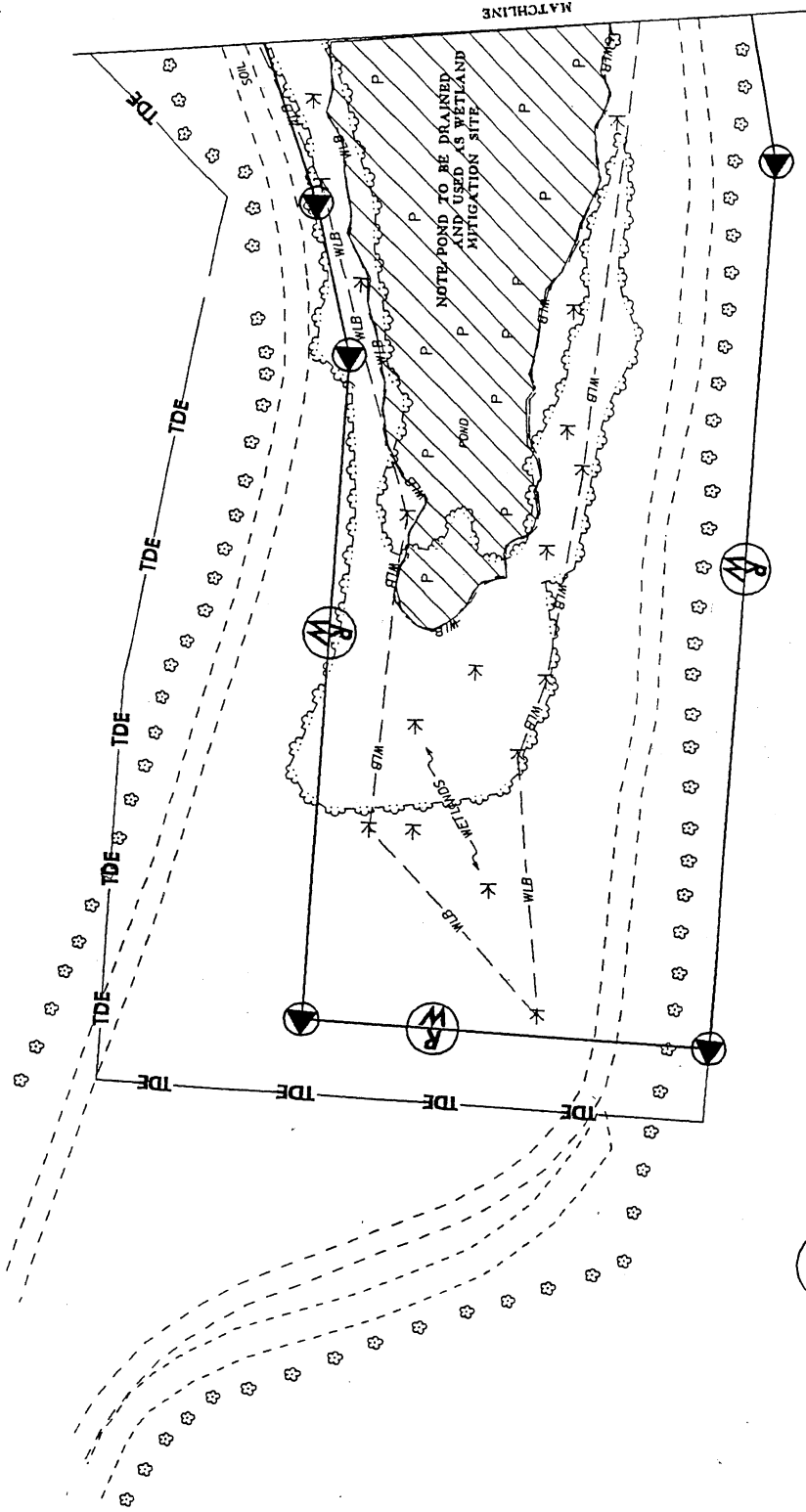

PLAN VIEW

N. C. DEPT. OF TRANSPORTATION
 DIVISION OF HIGHWAYS
 RICHMOND COUNTY
 PROJECT: 8.T550802 (R-2231B)

US 220 BYPASS

10/16/02

SHEET 31 OF 43

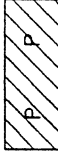
 DENOTES IMPACT TO POND

SITE 6 WETLAND MITIGATION SITE

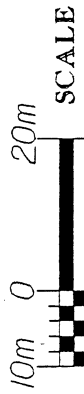

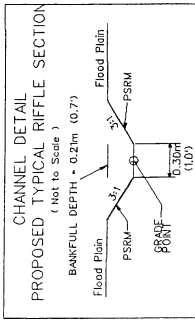

TYPICAL RIFFLE SECTION BETWEEN BENDS/POOLS

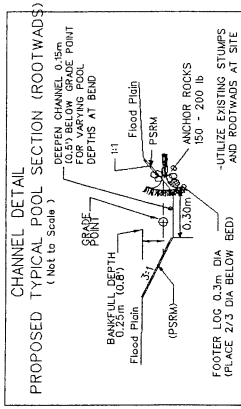

TYPICAL POOL SECTION WITH ROOTWAYS

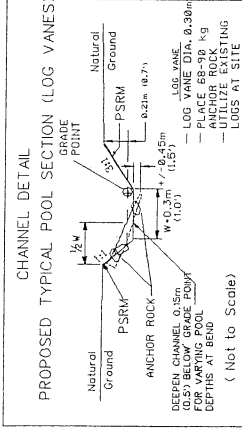

TYPICAL POOL SECTION WITH LOG VANES

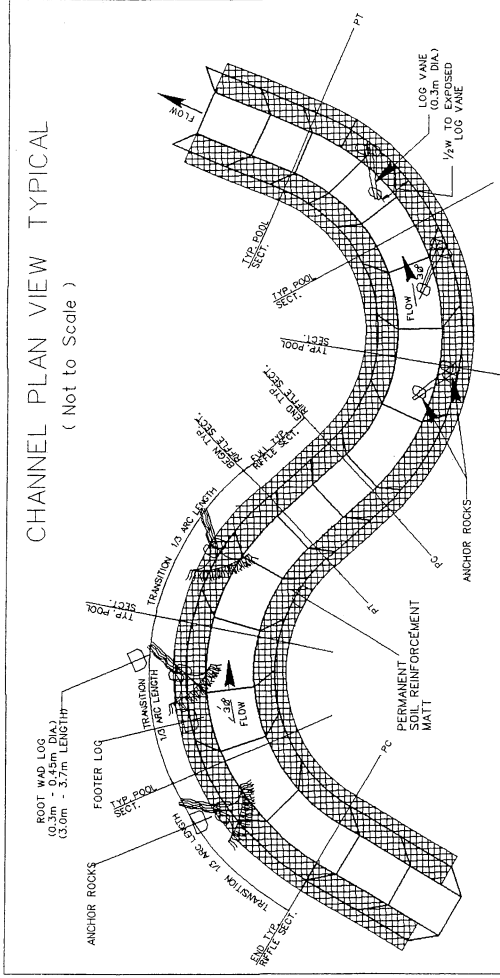

NOTES:

- NUMBER OF ROOTWAYS INSTALLED TO BE DETERMINED ON SITE
- ROOTWAYS TO BE SPACED 4x DIAMETER OF ROOT BASE
- FOOTER LOG ANCHOR ROCK TO BE PLACED ON THE DOWNSTREAM END OF EACH FOOTER LOG SO THAT IT IS LEANING AGAINST THE LOG ON THE SIDE AWAY FROM THE CHANNEL.
- WHEN BACKFILLING OVER AND AROUND FOOTER LOGS, ROOTWAY LOGS AND ANCHOR ROCKS FIRMLY SECURE ALL COMPONENTS INCLUDING JOINTS, CONNECTIONS AND GAPS.
- PERMANENT SOIL REINFORCEMENT MATT (PSRM)
- THE SITE HAS A NUMBER OF EXISTING STUMPS, ROOTWAYS AND LOG VANES AVAILABLE. THE BELIEVED STREAM CAN UTILIZE THESE STRUCTURES OR BE LOCATED TO INCORPORATE.

N. C. DEPT. OF TRANSPORTATION
DIVISION OF HIGHWAYS
RICHMOND COUNTY
PROJECT: 8.T550802 (R-2231B)

US 290 BYPASS

SHEET 32 OF 43

SITE 6 STREAM RESTORATION DETAILS
STA 140+00 -L- (RT)
TO 143+20 -L- (LT)

Appendix B

Morphological Measurement Table

Variables	Existing Channel	Proposed Reach	USGS Station	Reference Reach
1. Stream type	E5	E5	N/A	E5
2. Drainage area	160 Ac (0.25mi ²)	160 - 193 Ac		160 Ac (0.25mi ²)
3. Bankfull width	5.1 ft	5.2 ft		5.1ft
4. Bankfull mean depth	0.5 ft	0.4 ft		0.5 ft
5. Width/depth ratio	10.2	13		10.2
6. Bankfull cross-sectional area	2.2 ft ²	2.2 ft ²		2.2 ft ²
7. Bankfull mean velocity	3.7 ft/s	3.7 ft/s		3.7 ft/s
8. Bankfull discharge, cfs	8.1 ft ³ /s	8.1 ft ³ /s		8.1 cfs
9. Bankfull max depth	0.8 ft	0.7 ft		0.8 ft
10. Width of floodprone area	180 ft	150 - 180 ft		180 ft
11. Entrenchment ratio	112	88		112
12. Meander length	40 ft	30 - 50 ft		40 ft
13. Ratio of meander length to bankfull width	7.8	7.7		7.8
14. Radius of curvature	12 ft	12 ft		12 ft
15. Ratio of radius of curvature to bankfull width	2.4	2.3		2.4
16. Belt width	10 - 20 ft	15 - 20 ft		10 - 20 ft
17. Meander width ratio	2.9	3.4		2.9
18. Sinuosity (stream length/valley length)	1.10	1.16		1.10
19. Valley slope	1.30%	1.30%		1.30%
20. Average slope	0.90%	0.80%		0.90%
21. Pool slope	0.30%	0.00%		0.30%
22. Ratio of pool slope to average slope	0.33	0.38		0.33
23. Maximum pool depth	1.4 ft	1.2 ft		1.4 ft
24. Ratio of pool depth to average bankfull depth	2.8	2.2		2.8
25. Pool width	5 - 6 ft	5.8 ft		5 - 6 ft
26. Ratio of pool width to bankfull width	1.08	1.11		1.08
27. Pool to pool spacing	25 ft	25 ft		25 ft
28. Ratio of pool to pool spacing to bankfull width	4.9	4.8		4.9

**Ellerbe Bypass Stream Mitigation Site (R-2231B)
Sta 140+00 -L- (Rt) - Sta 143+20 -L- (Lt)**

SEDIMENT TRANSPORT ANALYSIS

Station/Description	Flow Depth (ft)	Flow Slope (ft/ft)	Shear Stress (lb/ft ²)	Bed Material	Velocity (ft/s)
Proposed	0.7	0.0080	0.203	Sand/Silt	2.9
Reference	0.8	0.0090	0.229	Sand/Silt	3.0

Note: Velocities determined from HEC-RAS Model

Proposed Morphology

**** Critical Shear Stress** 0.28 lb/ft²

***** Permissible Velocity** 2.0-3.5 ft/s

Clear Water Silt Loam - Water w/ Silt Firm Loam

* Shields:

Particle Size	8.0	mm
Dimensionless Shear Stress	0.0755	lb/ft ²
Kinematic Viscosity	0.00001400	ft ² /s
Mass Density	1.94	slugs/ft ³
Unit Weight (Particle)	165.0	lb/ft ³
Unit Weight (Water)	62.4	lb/ft ³
Reynolds Number	607.0	
Dimensionless Shear Stress from Shields Diagram	0.100	lb/ft ²

at 50° F

References:

- * Shields Diagram
- ** Hydraulic Engineering (HEC) 15 - Chart 1
- *** Hydraulic Design Series (HDS) 3 - Table 2

Proposed

Q_{BKF}	8.1	ft ³ /s
W/D	13.0	
Side Slope	3:1	
Mannings n	0.035	
Valley Slope	0.0130	ft/ft
Sinuosity	1.16	

Valley Slope/Sinuosity	0.0112	ft/ft
Velocity	2.9	ft/s
Area	2.2	ft ²
W_{BKF}	5.2	ft
Base Width	1.0	ft
Mean Depth	0.4	ft
Wetted Perimeter	5.4	ft
Hydraulic Radius	0.41	ft

Shear Stress	0.28	lb/ft ²
Particle Moved	18.0	mm

Reference

	8.1	ft ³ /s
	10.2	
	Var.	
	0.035	
	0.0130	ft/ft
	1.10	

	0.0118	ft/ft
	3.0	ft/s
	2.2	ft ²
	5.1	ft
	Var. - 2	ft
	0.5	ft
	5.4	ft
	0.41	ft

	0.30	lb/ft ²
	16.0	mm

Stream Power:

Reference:
stream power = 0.135 lb/ft/sec

Proposed:
stream power = 0.113 lb/ft/sec

Elev (m)

165.00000

160.00000

150.00000

0.00000 10.00000 20.00000 30.00000 40.00000 50.00000 60.00000 70.00000 80.00000 90.00000 100.00000 110.00000 120.00000 130.00000 140.00000 150.00000 160.00000 170.00000 180.00000 190.00000 200.00000

PROPOSED STREAM GRADE

EXISTING GROUND

BANKFULL

BED

POOL

Distance (m)

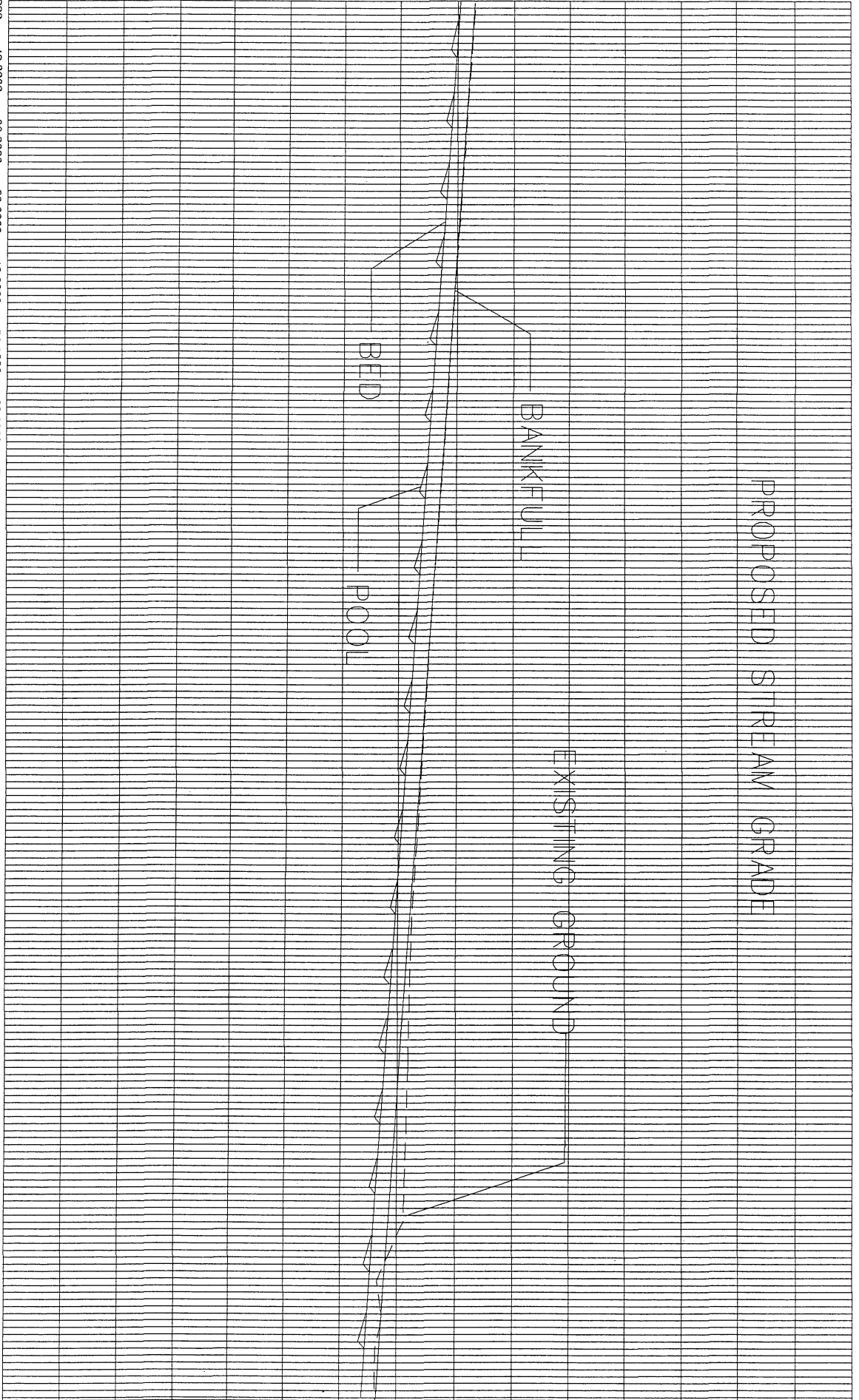

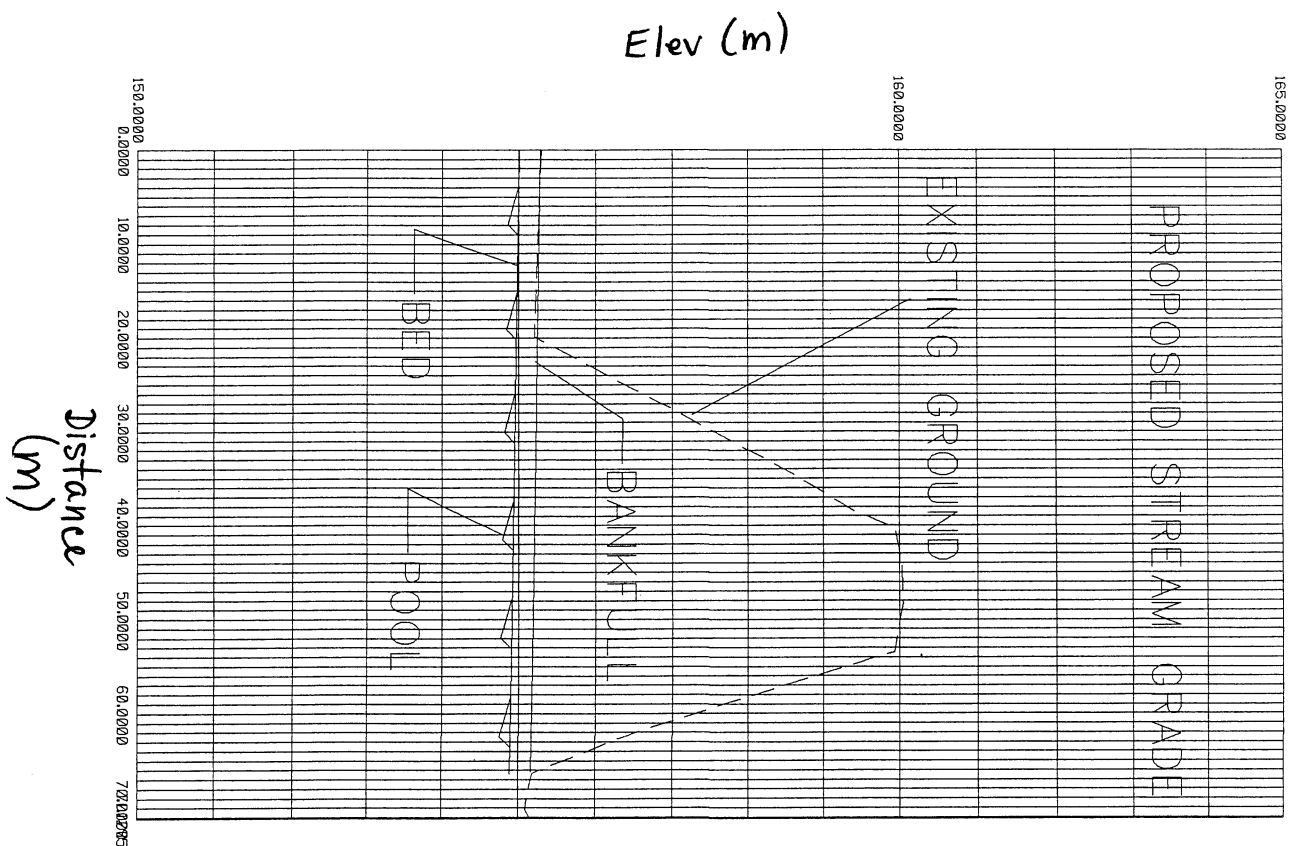

PROJECT #: 8.T550803 (R-2231B)
COUNTY: RICHMOND
DESCRIPTION: US 220 BYPASS FROM SOUTH OF
SR 1455 TO NORTH OF NC 73
STREAM: TRIBUTARY TO ROCKY FORD BRANCH

NATURAL STREAM DESIGN
Sta 140+60 -L- (Rt) - Sta 144+00 -L- (Lt)

The proposed new location of the US 220 Bypass (Ellerbe Bypass) will result in the impact (draining) of an existing pond at Sta 141+00 -L-. Once the pond is drained, it is proposed to use the area as a mitigation site including the construction of a natural stream. The stream that feeds the pond is a tributary to Rocky Ford Branch. The stream will be designed/classified based on Dave Rosgen's principles and techniques for river morphology.

The existing stream drains 160 acres at the head of the pond up to 193 acres at the outlet. The basin is rural and is located in the Sandhills hydrologic region. The basin drains pine/hardwood forest and agricultural fields. The existing stream was determined stable, undisturbed and was therefore used for the reference stream. The reference reach was located at the head of the existing pond.

The stream reference reach was surveyed to determine its morphological characteristics. These characteristics include bankfull area, depth, width and discharge. This information was then compared to data generated from the NC Stream Restoration Institute's regional equations for bankfull characteristics. The Piedmont region was used with the NCSRI equations and prorated for the Sandhills region. The USGS Rural WRI Report 99-4114 was used to establish the prorated ratios between the Piedmont and Sandhills regions. Data was also analyzed using the HEC-RAS modeling system to compare the accuracy of the characteristics between the surveyed reach and the regional equations.

The reference reach bed material was found to be fine to medium sand. The shear stress and sediment transport properties for sand were analyzed. Shear stresses for the proposed and reference stream were calculated based on velocities and flow depths generated from the HEC-RAS modeling system. This information was then compared to values for critical velocity and shear stress for sand in the HEC-15 and HDS-5 manuals from the FHA. The comparison showed the proposed stream to be within acceptable velocity and shear stress limits that would allow proper sediment transport under bankfull conditions. Sediment transport characteristics were also analyzed using the Shields diagram. This also showed the fine to medium sand being moved under the bankfull conditions.

The proposed stream was designed to retain the bankfull characteristics of the reference stream. To aid in bank stability, log vanes and rootwads are proposed in the bend/pool areas. Also, permanent soil reinforcement mat will be placed on the banks along the entire proposed reach. This will enable vegetation to establish along the stream banks.

Based on surveyed data in the field and analyzed information provided by the NCSRI, the tributary to Rocky Ford Branch was classified as an E5 stream. According to Rosgen's **Applied River Morphology**, E5 streams are characterized as "hydraulically efficient channel forms" with a "high sediment transport capacity" and a "high resistance to plan form adjustment which results in channel stability without significant downcutting." They are found in broad alluvial valleys with well developed floodplains. The stream banks "are composed of materials finer than that of the dominant channel bed materials and are typically stabilized with extensive riparian or wetland vegetation that forms densely rooted sod mats from grasses, as well as woody species." The E5 stream retains these very stable characteristics "unless the stream banks are disturbed and significant changes in sediment supply and/or streamflow occur."

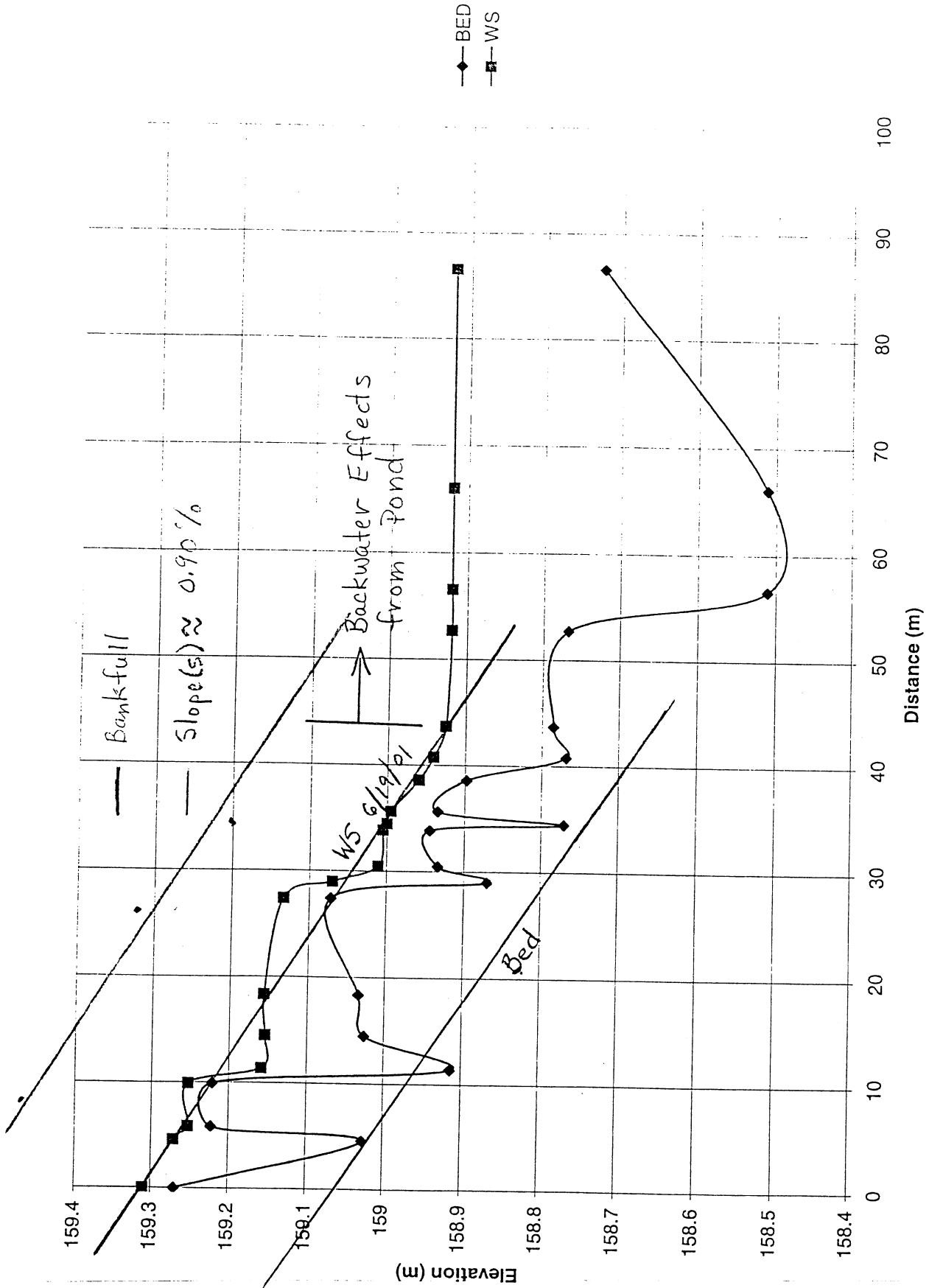

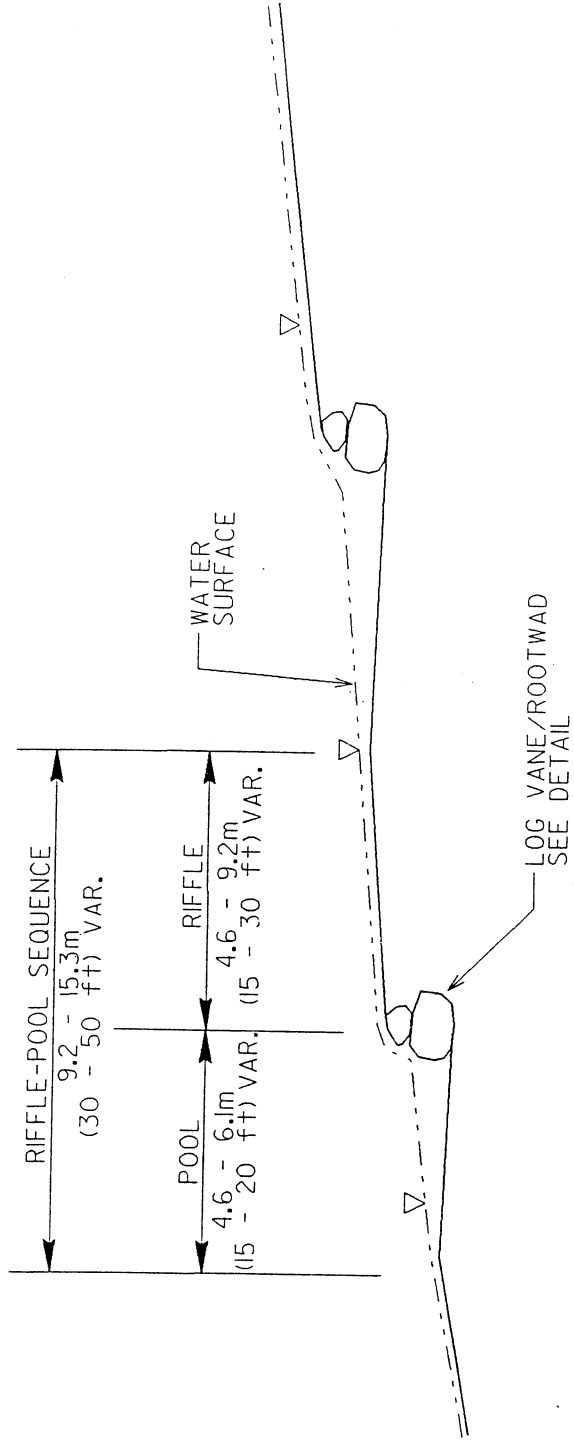

RIFFLE-POOL SPACING SITE 6

NOT TO SCALE

N. C. DEPT. OF TRANSPORTATION
DIVISION OF HIGHWAYS
RICHMOND COUNTY
PROJECT: 8.T550802 (R-2231B)

US 220 BYPASS

PARCEL NO.	PROPERTY OWNER NAME	PROPERTY OWNER ADDRESS
①	EMMA & ROLYN ELLERBE	RT 4 BOX 295 WADESBORO, N.C. 28170
②	JOSEPH G. JR. & BETTY DAVIS	915 MORNINGSIDE DR. ROCKINGHAM, N.C. 28379
③	ROBERT LEE & BRENDA KAY THORSBY	PO BOX 212 ELLERBE, N.C. 28338
④	MELVIN G ELLINGER	PO BOX 1152 ELLERBE, N.C. 28338
⑤	DUNCAN H & CHARLOTTE Q GRANT	1836 N. US. HWY 220 ELLERBE, N.C. 28338
⑥	NEAL HAYWOOD GRANT	1836 N. US. HWY 220 ELLERBE, N.C. 28338
⑦	DANIEL BROWN JR	PO BOX 604 ELLERBE, N.C. 28338
⑧	BOBBY ANN NICHOLSON TERRY	PO BOX 352 ELLERBE, N.C. 28338
⑨ & ⑩	JUANITA ASKEW	1230 SOJRRREL HILL RD. CHARLOTTE, N.C. 28213
⑪	HAROLD JEROME NICHOLSON	PO BOX 152 ELLERBE, N.C. 28338
⑫	WALTER RAY & EMMA STANCIL	127 STANCIL DR. ELLERBE, N.C. 28338
⑬	ANNIE JORDAN BUJE	PO BOX 216 ELLERBE, N.C. 28338
⑭	ANTHONY A & BRENDA CAPEL	PO BOX 462 ELLERBE, N.C. 28338
⑰ & ⑱	ROGER H ALLRED SR	6726 LANCER DR. CHARLOTTE, N.C. 28226
⑳	JOHN B & BETTY PARKER	109 PATTERNOTE RD. MOORESVILLE, N.C. 28115
㉒	LESTER WILLIAM HINES	840 CAPEL MILL RD. ELLERBE, N.C. 28338

N.C. DEPT. OF TRANSPORTATION
DIVISION OF HIGHWAYS
RICHMOND COUNTY

PROJECT R-2231B

US 220 BYPASS

9/02

WETLAND PERMIT IMPACT SUMMARY

Site No.	Station (From/To)	Structure Size / Type	WETLAND IMPACTS				SURFACE WATER IMPACTS					
			Fill In Wetlands (ac)	Temp. Fill In Wetlands (ac)	Excavation In Wetlands (ac)	Mechanized Clearing (Method III) (ac)	Fill In SW (Natural) (ac)	Fill In SW (Pond) (ac)	Temp. Fill In SW (ac)	Existing Channel Impacted (ft)	Natural Stream Design (ft)	
1A	68+12 - 68+74 -L-	2@9'X8'	1.01		0.52	0.11	0.07				571	
1B	85+60 - 86+04 -L-	48" RCP	0.18			0.1	0.04				292	
1C	90+08 - 90+20 -L-	N/A	0.22			0.02						
1	91+20 - 94+00 -L-	30" RCP	1.7			0.16					663	
2	103+80 - 105+20 -L-	3@36" RCP	1.34			0.06						
3	106+60 - 110+00 -L-	42" RCP	2.41			0.23						
4	22+80 - 23+20 -Y4REV-	36" RCP	0.2			0.05					328	
5	135+00 - 137+00 -L-	30" RCP							3			
*6	140+00 - 142+00 -L-	54" RCP							9.36			1066
TOTALS:			7.06	0	0.52	0.73	0.11	12.36	0	1854	1066	

* WETLAND SITE 6 MITIGATION ESTIMATE = 3.12 Ac

NC DEPARTMENT OF TRANSPORTATION
DIVISION OF HIGHWAYS

RICHMOND COUNTY
PROJECT 8.T550802 (R-2231B)

11/02 SHEET 42 OF 43

WETLAND PERMIT IMPACT SUMMARY

Site No.	Station (From/To)	Structure Size / Type	WETLAND IMPACTS			SURFACE WATER IMPACTS						
			Fill In Wetlands (ha)	Temp. Fill In Wetlands (ha)	Excavation In Wetlands (ha)	Mechanized Clearing (Method III) (ha)	Fill In SW (Natural) (ha)	Fill In SW (Pond) (ha)	Temp. Fill In SW (ha)	Existing Channel Impacted (m)	Natural Stream Design (m)	
1A	68+12 - 68+74 -L-	2@2.7mX2.4m	0.41		0.211	0.045	0.028				174	
1B	85+60 - 86+04 -L-	1200 RCP	0.39			0.041	0.017				89	
1C	90+08 - 90+20 -L-	N/A	0.087			0.008						
1	91+20 - 94+00 -L-	750 RCP	0.688			0.063					202	
2	103+80 - 105+20 -L-	3@900 RCP	0.543			0.023						
3	106+60 - 110+00 -L-	1050 RCP	0.976			0.094					100	
4	22+80 - 23+20 -Y4REV-	900 RCP	0.082			0.021						
5	135+00 - 137+00 -L-	750 RCP							1.21			
* 6	140+00 - 142+00 -L-	1350 RCP							3.79			325
TOTALS:			3.176	0	0.211	0.295	0.045	5.00	0	565	325	

* WETLAND SITE 6 MITIGATION ESTIMATE = 1.27 Ha

Form Revised 3/22/01

NCDOT

DIVISION OF HIGHWAYS
 RICHMOND COUNTY
 PROJECT 8.TF50802 (R-2231B)

11/02

SHEET 43 OF 43

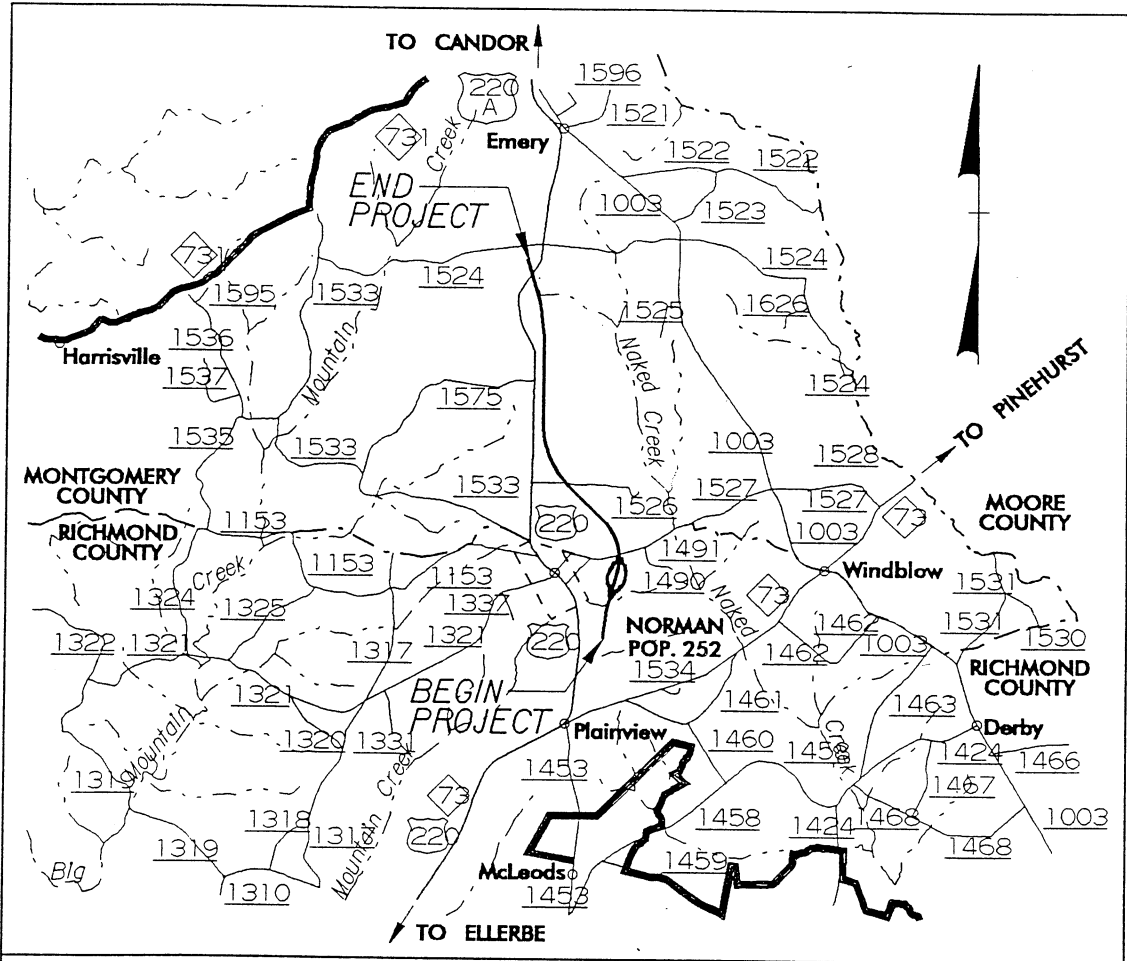
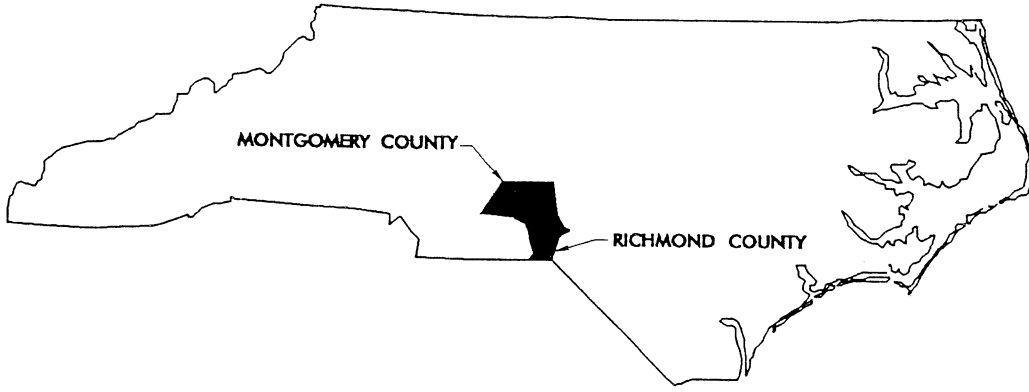









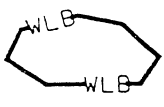

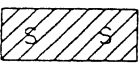
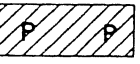

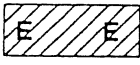

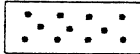
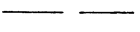

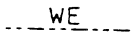
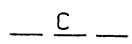
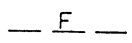

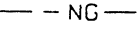
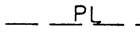
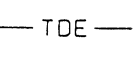
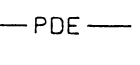
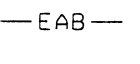
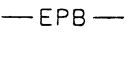
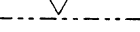
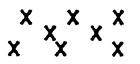

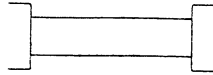
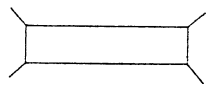
SKETCH MAP SHOWING LOCATION OF STATE PROJECT 8.T550803

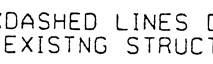
VICINITY MAP

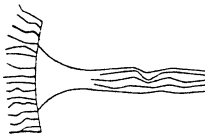
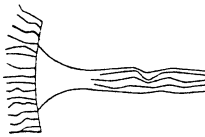
NORTH CAROLINA DEPARTMENT OF TRANSPORTATION
 DIVISION OF HIGHWAYS
 RICHMOND/MONTGOMERY COUNTIES
 8.T550803 R-2231CA
 US 220 BYPASS FROM NORTH OF
 NC 73 TO SOUTH OF SR 1524
 NOT TO SCALE
 SEPTEMBER 2002

WETLAND LEGEND

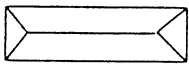
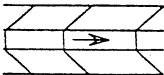
-  WETLAND BOUNDARY
-  WETLAND
-  DENOTES FILL IN WETLAND
-  DENOTES FILL IN SURFACE WATER
-  DENOTES FILL IN SURFACE WATER (POND)
-  DENOTES TEMPORARY FILL IN WETLAND
-  DENOTES EXCAVATION IN WETLAND
-  DENOTES TEMPORARY FILL IN SURFACE WATER
-  DENOTES MECHANIZED CLEARING
-  FLOW DIRECTION
-  TOP OF BANK
-  EDGE OF WATER
-  PROP. LIMIT OF CUT
-  PROP. LIMIT OF FILL
-  PROP. RIGHT OF WAY
-  NATURAL GROUND
-  PROPERTY LINE
-  TEMP. DRAINAGE EASEMENT
-  PERMANENT DRAINAGE EASEMENT
-  EXIST. ENDANGERED ANIMAL BOUNDARY
-  EXIST. ENDANGERED PLANT BOUNDARY
-  WATER SURFACE
-  LIVE STAKES
-  BOULDER
-  CORE FIBER ROLLS
-  PROPOSED BRIDGE
-  PROPOSED BOX CULVERT
-  PROPOSED PIPE CULVERT
12"-48" PIPES
54" PIPES & ABOVE
-  (DASHED LINES DENOTE EXISTING STRUCTURES)
-  SINGLE TREE
-  WOODS LINE
-  DRAINAGE INLET
-  ROOTWAD
-  RIP RAP
-  ADJACENT PROPERTY OWNER OR PARCEL NUMBER IF AVAILABLE
-  PREFORMED SCOUR HOLE (PSH)
-  LEVEL SPREADER (LS)
-  GRASS SWALE

N. C. DEPT. OF TRANSPORTATION
DIVISION OF HIGHWAYS
RICHMOND/MONTGOMERY COUNTIES
PROJECT: 8.T550803 (R-2231CA)
US 220 BYPASS
FROM NORTH OF NC 73 TO
SOUTH OF SR 1524
SHEET 12 OF 14 9/00

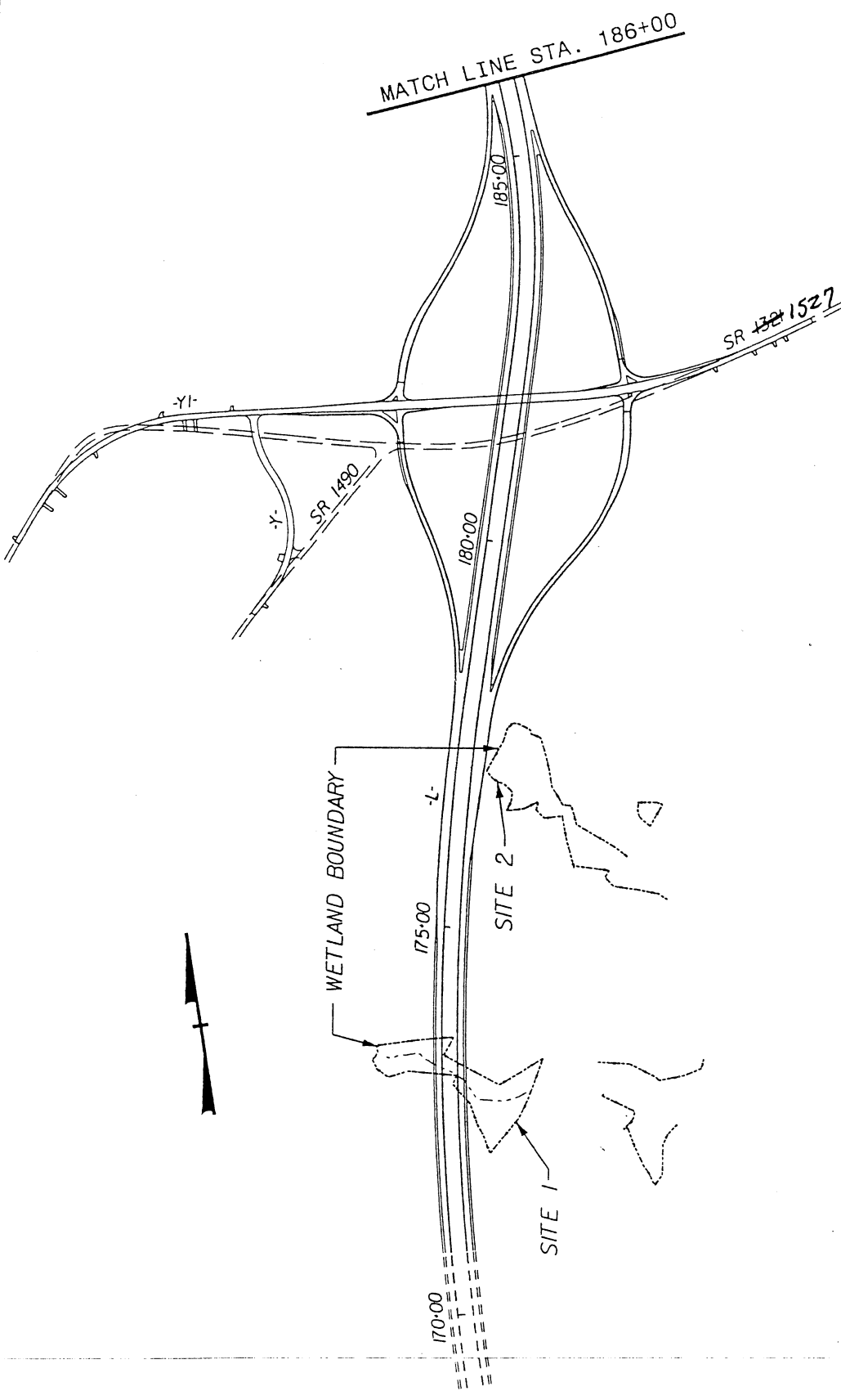

MATCH LINE STA. 186+00

SR ~~1527~~ 1527

WETLAND BOUNDARY

SITE 2

SITE 1



NORTH CAROLINA DEPARTMENT OF TRANSPORTATION
 DIVISION OF HIGHWAYS
 RICHMOND/MONTGOMERY COUNTIES
 B.T550803 R-2231CA
 US 220 BYPASS FROM NORTH OF NC 73
 TO SOUTH OF SR 1524

9/02

SHEET 3 OF 14

MATCH LINE STA. 234+00

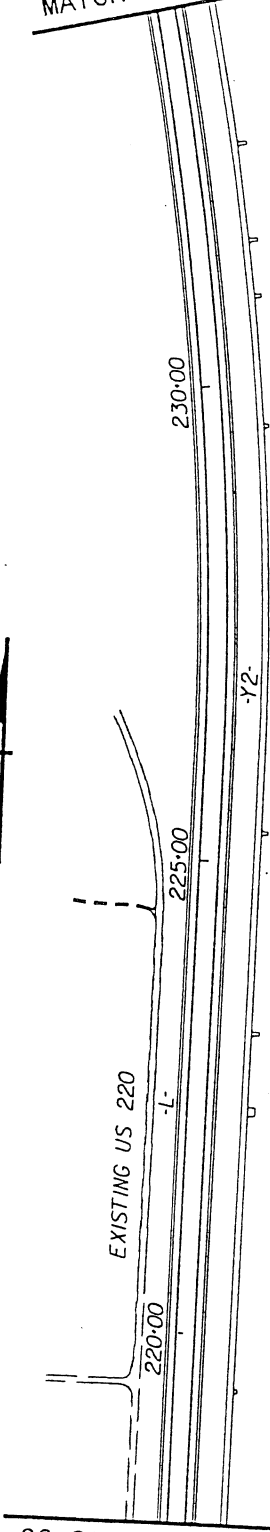

MATCH LINE STA. 218+00

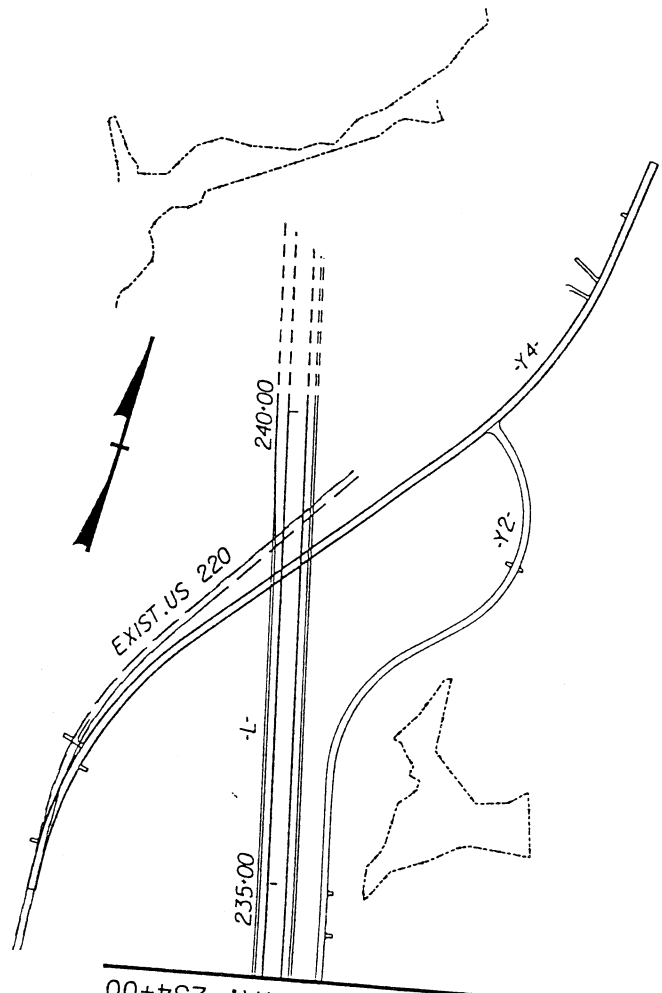

MATCH LINE STA. 234+00

NORTH CAROLINA DEPARTMENT OF TRANSPORTATION
DIVISION OF HIGHWAYS
RICHMOND/MONTGOMERY COUNTIES
B. 1550803 R. 2231CA
US 220 BYPASS FROM NORTH OF NC 73
TO SOUTH OF SR 1524

9/02

SHEET 5 OF 14

Q SECTION

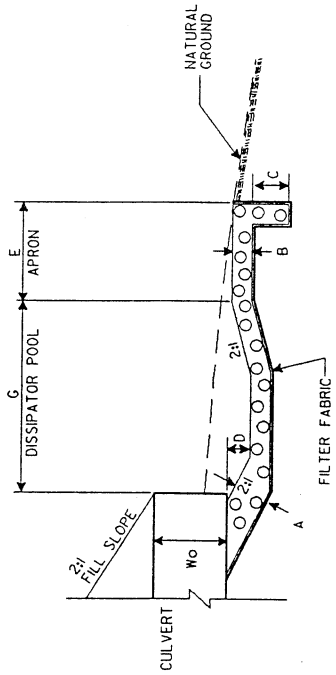

HALF PLAN

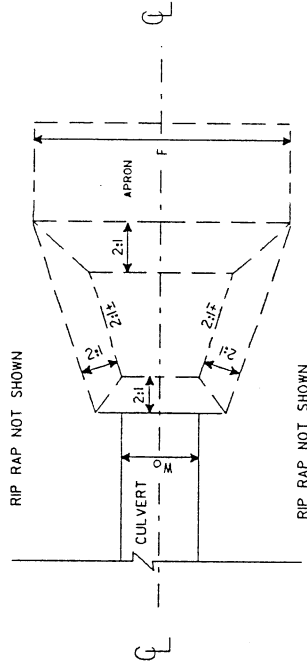

DIM.	RIP RAP BASIN #				
(m)	1	2	3	4	5
A	0.60	0.60	0.60	0.60	0.60
B	0.40	0.40	0.40	0.40	0.40
C	1.20	1.20	1.20	1.20	1.20
D	0.60	0.60	0.60	0.60	0.60
E	3.0	3.0	3.0	3.0	3.0
F	6.0	6.0	6.0	6.0	6.0
G	6.0	6.0	6.0	6.0	6.0

ALL DIMENSIONS APPROXIMATE

BASIN #	LOCATION (AT OUTLET)
1	Sta 173+40 -L- (Rt)
2	Sta 176+60 -L- (Rt)
3	Sta 189+10 -L- (Rt)
4	Sta 191+80 -L- (Rt)
5	Sta 1+70 -RPC- (Rt)

DETAIL OF RIP-RAPPED OUTLET ENERGY DISSIPATOR BASIN

STATE OF NORTH CAROLINA
DIVISION OF HIGHWAYS
RALEIGH, N.C.

N. C. DEPT. OF TRANSPORTATION
DIVISION OF HIGHWAYS
RICHMOND / MONTGOMERY
COUNTY
PROJECT: 8.T550803 (R-2231CA)
US 220 BYPASS FROM NORTH OF
NC 73 TO SOUTH OF SR 1524

9/02

SHEET 6 OF 14

PREFORMED SCOUR HOLE

PLAN VIEW

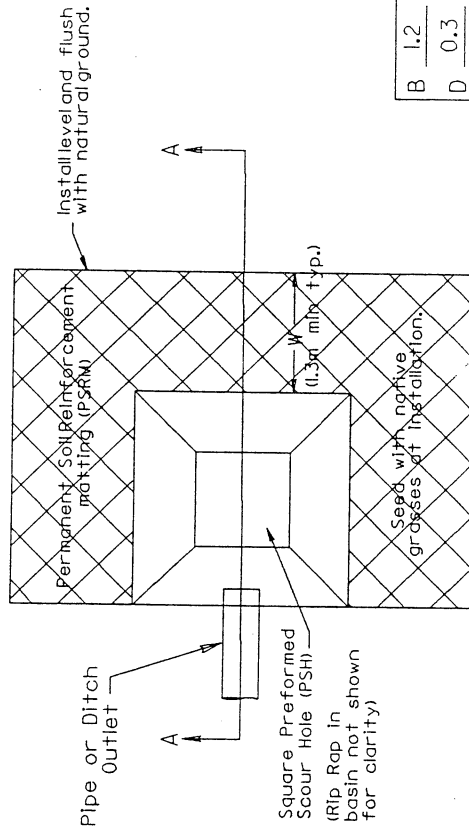

B	1.2
D	0.3
W	1.3
d	0.075

SECTION A-A

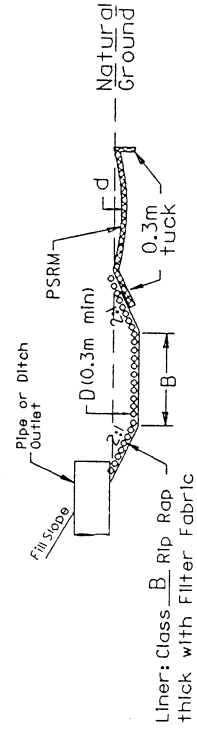

N. C. DEPT. OF TRANSPORTATION
 DIVISION OF HIGHWAYS
 RICHMOND / MONTGOMERY COUNTY
 PROJECT: 8.T550803 (R-2231CA)
 US 220 BYPASS FROM NORTH OF NC 73 TO SOUTH OF SR 1524

9/02

176+00

177+00

178+00

179+00

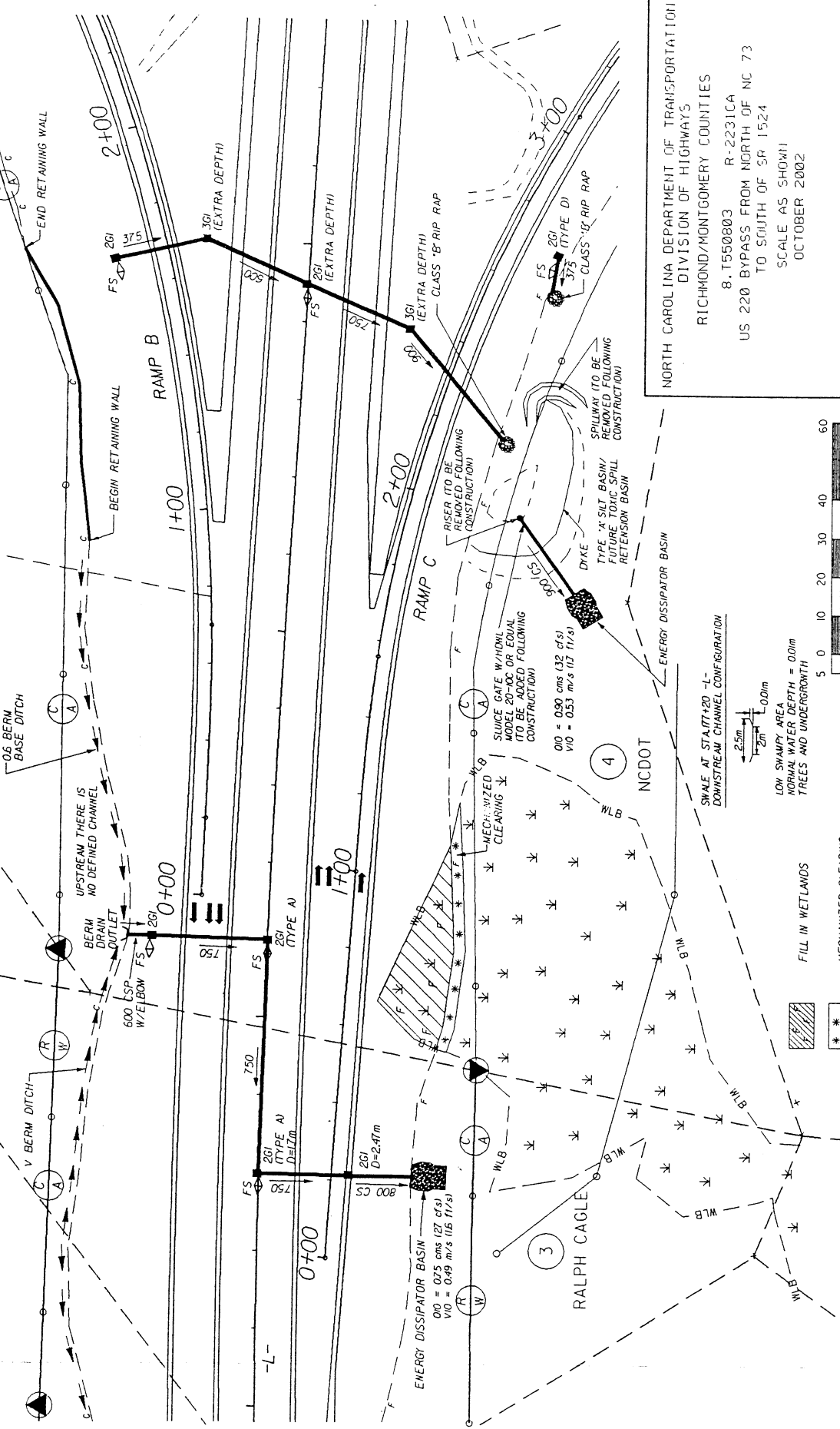

NORTH CAROLINA DEPARTMENT OF TRANSPORTATION
 DIVISION OF HIGHWAYS
 RICHMOND/MONTGOMERY COUNTIES
 8.1550803 R-2231CA
 US 220 BYPASS FROM NORTH OF NC 73
 TO SOUTH OF SR 1524
 SCALE AS SHOWN
 OCTOBER 2002

SHEET 9 OF 14 SITE II

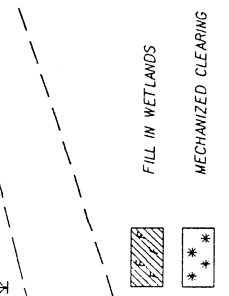
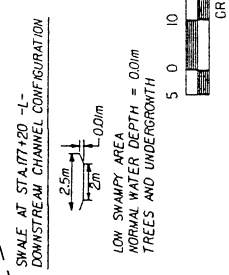

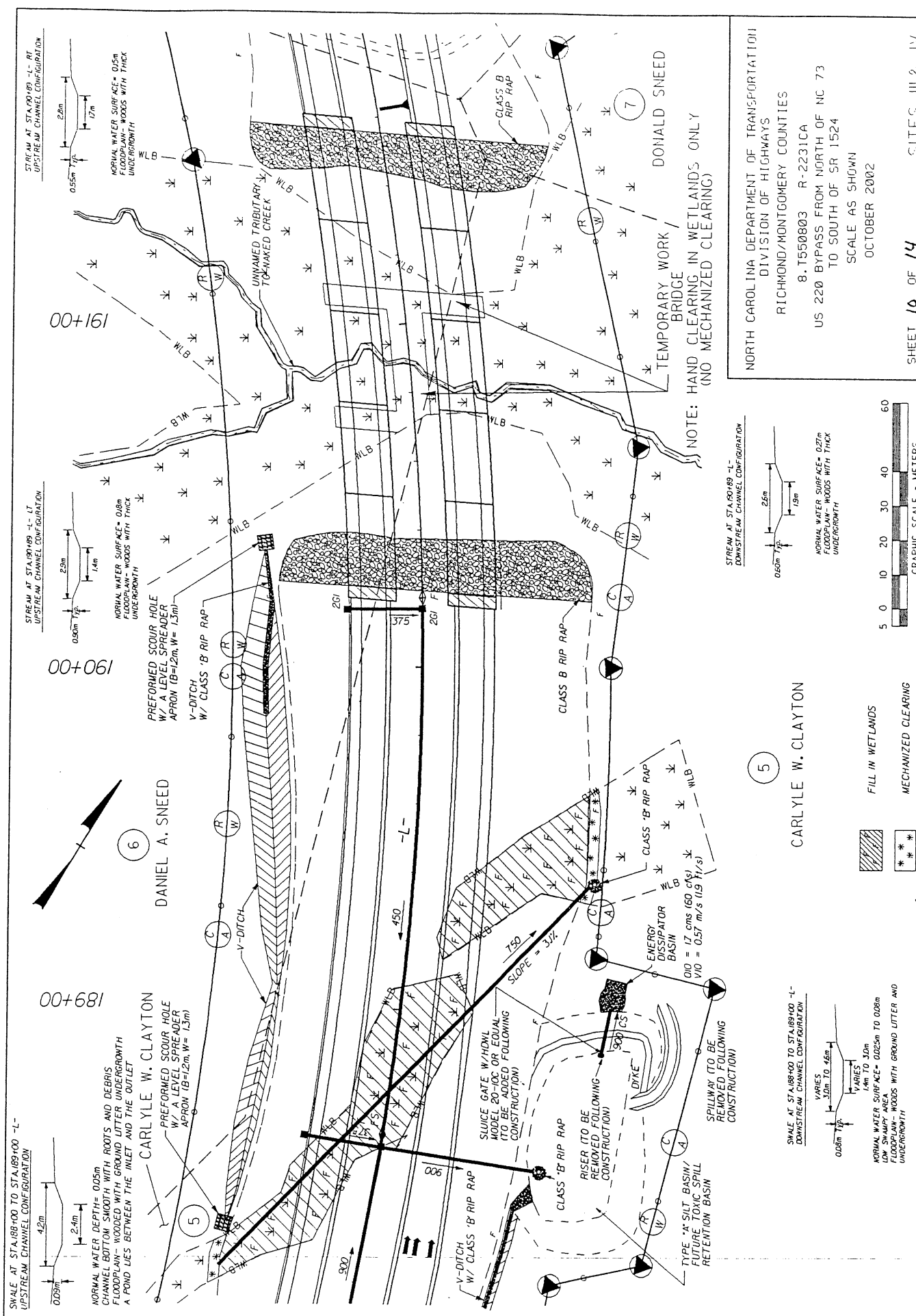

SWALE AT STA. 189+00 TO STA. 189+00 -L-
UPSTREAM CHANNEL CONFIGURATION

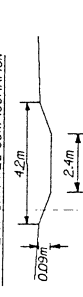

NORMAL WATER DEPTH= 0.05m
CHANNEL BOTTOM SMOOTH WITH ROOTS AND DEBRIS
FLOODPLAIN= WOODS WITH GROUND LITTER UNDERGROWTH
A POND LIES BETWEEN THE INLET AND THE OUTLET

00+681



00+601

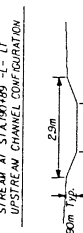

00+161

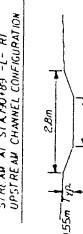

STREAM AT STA. 169+00 -L- RT
UPSTREAM CHANNEL CONFIGURATION

SWALE AT STA. 189+00 TO STA. 189+00 -L-
DOWNSTREAM CHANNEL CONFIGURATION

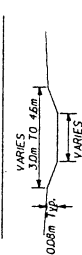

NORMAL WATER SURFACE= 0.025m TO 0.08m
FLOODPLAIN= WOODS WITH GROUND LITTER AND UNDERGROWTH

STREAM AT STA. 169+00 -L-
DOWNSTREAM CHANNEL CONFIGURATION

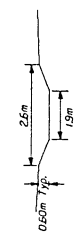

NORMAL WATER SURFACE= 0.27m
FLOODPLAIN= WOODS WITH THICK UNDERGROWTH



FILL IN WETLANDS
MECHANIZED CLEARING

CARLYLE W. CLAYTON

5

DANIEL A. SNEED

6

CARLYLE W. CLAYTON

5

TEMPORARY WORK
BRIDGE
DONALD SNEED

NOTE: HAND CLEARING IN WETLANDS ONLY
(NO MECHANIZED CLEARING)

NORTH CAROLINA DEPARTMENT OF TRANSPORTATION
DIVISION OF HIGHWAYS
RICHMOND/MONTGOMERY COUNTIES
8.1550803 R-2231CA
US 220 BYPASS FROM NORTH OF NC 73
TO SOUTH OF SR 1524
SCALE AS SHOWN
OCTOBER 2002

SHEET 10 OF 14 SITES III & IV

TYPICAL SECTION OF BRIDGE

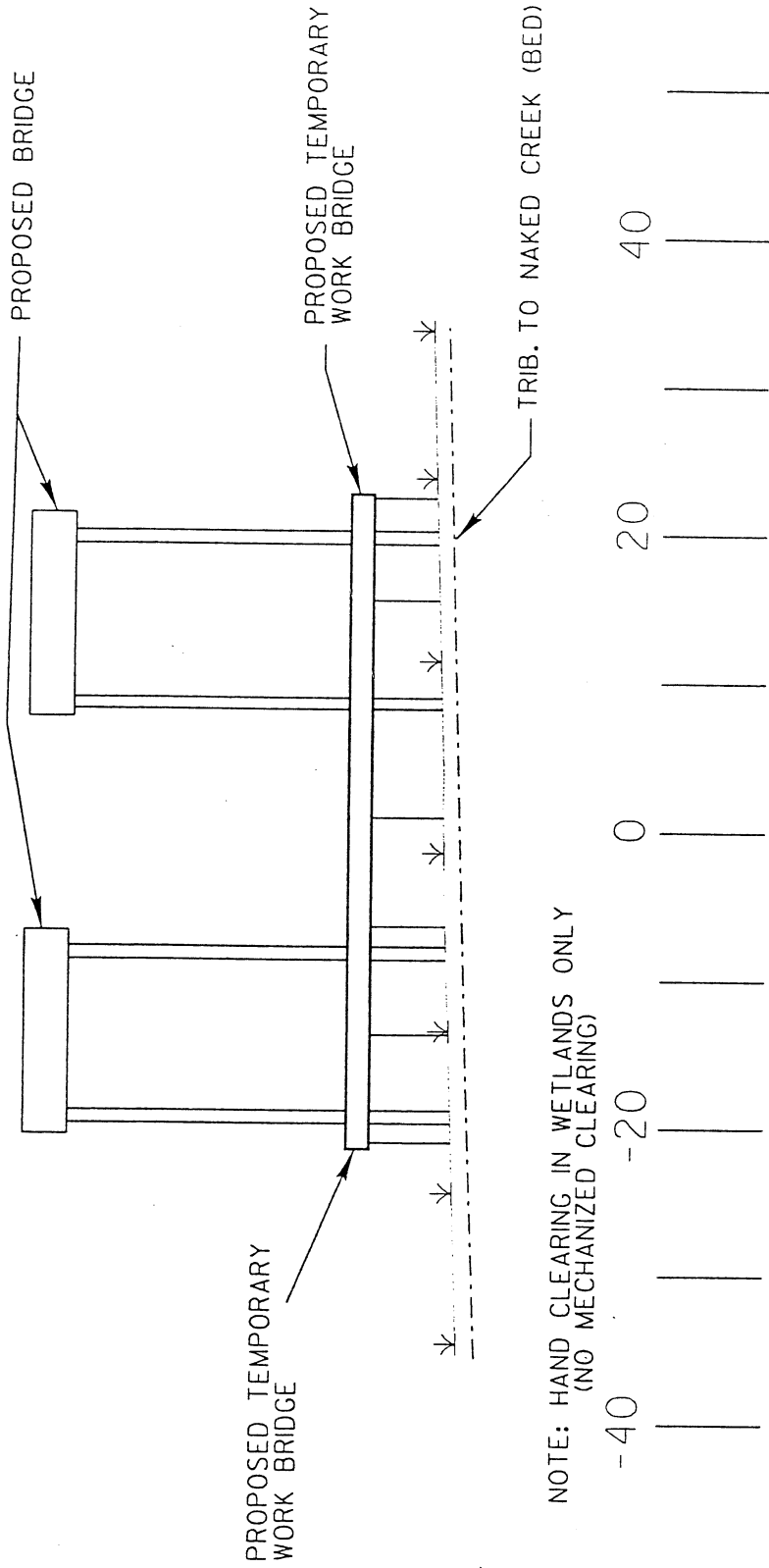

170

165

160

155

150

CROSS SECTION



N. C. DEPT. OF TRANSPORTATION
 DIVISION OF HIGHWAYS
 RICHMOND / MONTGOMERY COUNTY
 PROJECT: 8.T550803 (R-2231CA)
 US 220 BYPASS FROM NORTH
 OF NC 73 TO SOUTH OF SR 1524

9/02

NOTE: HAND CLEARING IN WETLANDS ONLY
(NO MECHANIZED CLEARING)

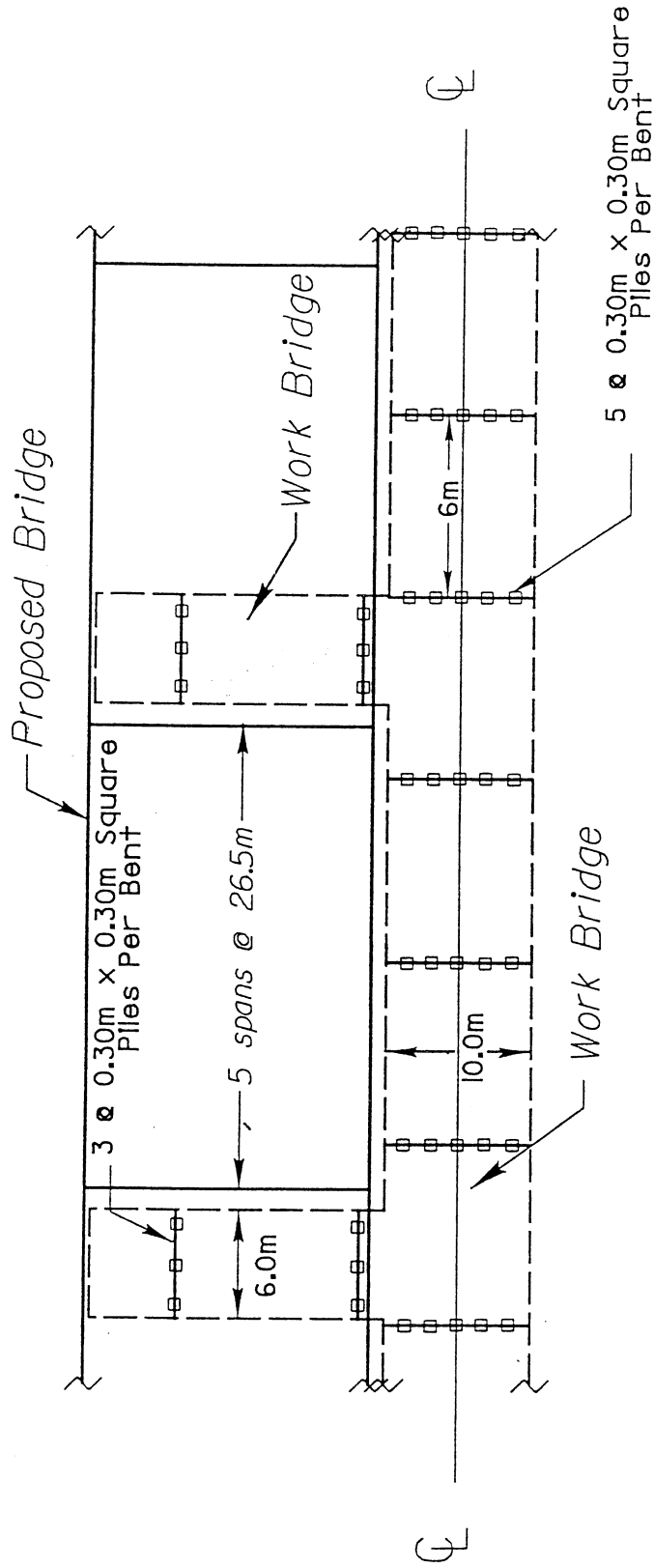

TYPICAL WORK BRIDGE

(NOT TO SCALE)

Permanent Fill In Wetlands (Piles)
- Negligible Due to 0.3m HP Steel Piles

Temporary Fill In Wetlands (Piles)
(112 piles)(0.30m x 0.30m) = 10.0 sq. m.

N. C. DEPT. OF TRANSPORTATION
DIVISION OF HIGHWAYS
RICHMOND / MONTGOMERY COUNTY

PROJECT: 8.T550803 (R-2231CA)
US 220 BYPASS FROM NORTH
OF NC 73 TO SOUTH OF SR 1524

9/02
SHEET 12 OF 14

WETLAND PERMIT IMPACT SUMMARY

Site No.	Station (From/To)	Structure Size / Type	WETLAND IMPACTS				SURFACE WATER IMPACTS				Natural Stream Design (m)
			Fill In Wetlands (ha)	Temp. Fill In Wetlands (ha)	Excavation In Wetlands (ha)	Mechanized Clearing (Method III) (ha)	Fill In SW (Natural) (ha)	Fill In SW (Pond) (ha)	Temp. Fill In SW (ha)	Existing Channel Impacted (m)	
I	173+00 +/- -L-	900mm RCP	0.3652	-	-	0.039	0.0064	-	-	106.97	-
II	177+00 +/- -L- RT 188+20 +/- -L- LT TO 189+60 +/- -L- RT	800mm CSP 750mm RCP	0.0515 0.2645	- -	- -	0.018 0.014	- -	- -	- -	- -	- -
IV	190+89 +/- -L-	DUAL BRIDGES	-	-	-	-	-	-	-	-	-
TOTALS:			0.6812	-	-	0.071	0.0064	-	-	106.97	-

Site No.	Station (From/To)	Structure Size / Type	WETLAND IMPACTS				SURFACE WATER IMPACTS				Natural Stream Design (ft)
			Fill In Wetlands (ac)	Temp. Fill In Wetlands (ac)	Excavation In Wetlands (ac)	Mechanized Clearing (Method III) (ac)	Fill In SW (Natural) (ac)	Fill In SW (Pond) (ac)	Temp. Fill In SW (ac)	Existing Channel Impacted (ft)	
I	173+00 +/- -L-	36 in RCP	0.9020	-	-	0.100	0.016	-	-	351	-
II	177+00 +/- -L- RT 188+20 +/- -L- LT TO 189+60 +/- -L- RT	30 in CSP 30 in RCP	0.1270 0.6540	- -	- -	0.050 0.035	- -	- -	- -	- -	- -
IV	190+89 +/- -L-	DUAL BRIDGES	-	-	-	-	-	-	-	-	-
TOTALS:			1.6830	-	-	0.185	0.016	-	-	351	-

NCDOT
 DIVISION OF HIGHWAYS
 RICHMOND/MONTGOMERY COUNTIES
 PROJECT 8.T550803 (R-2231 CA)
 US 220 BYPASS FROM NORTH OF
 NC 73 TO SOUTH OF SR 1524

PROPERTY OWNERS

PARCEL	OWNERS NAME	ADDRESS
1	HAMLET FEDERAL CREDIT UNION DB. 0744-0255	P.O. BOX 271, HAMLET, NC 28345
2	ELVIN CRANFORD DB. 0468-0048	P.O. BOX 85, NORMAN, NC 28367
3	RALPH CAGLE DB. 0540-0503	BOX 113, NORMAN, NC 28367
4	NCDOT	
5	CARLYLE W. CLAYTON DB. 0156-0065	501 E. WHITAKERMILL ROAD, RALEIGH, NC 27608
6	DANIEL A. SNEED DB. 0097-0105	173 SNEED DRIVE, CANDOR, NC 27229
7	DONALD SNEED DB. 0137-399	322 MORGAN ROAD, CANDOR, NC 27229

NORTH CAROLINA DEPARTMENT OF TRANSPORTATION
 DIVISION OF HIGHWAYS
 RICHMOND/MONTGOMERY COUNTIES
 8, T5508003 R-2231CA
 US 220 BYPASS FROM NORTH OF NC 73
 TO SOUTH OF SR 1524

SEPTEMBER 2002

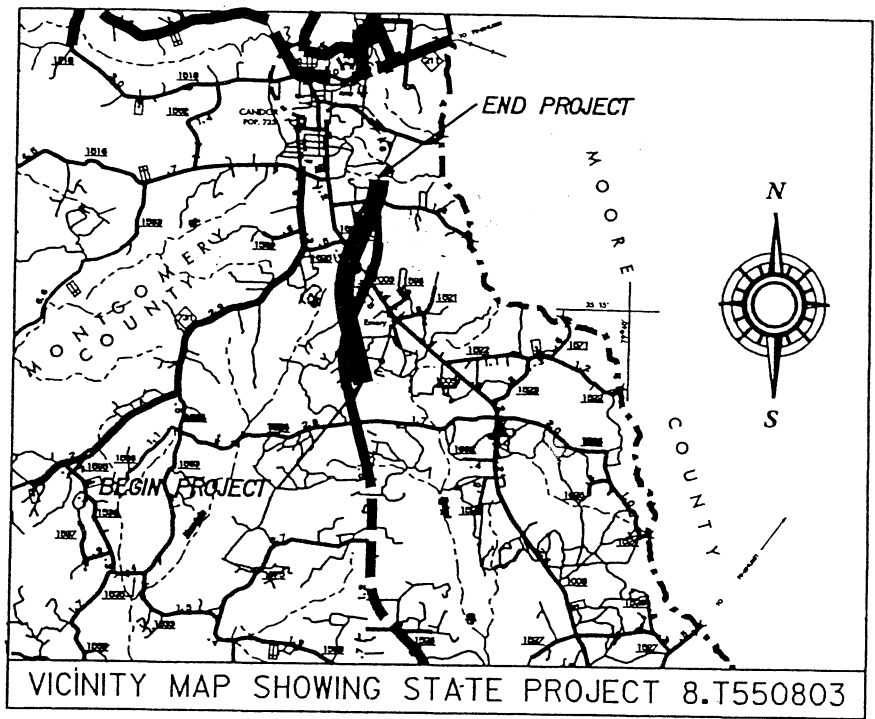
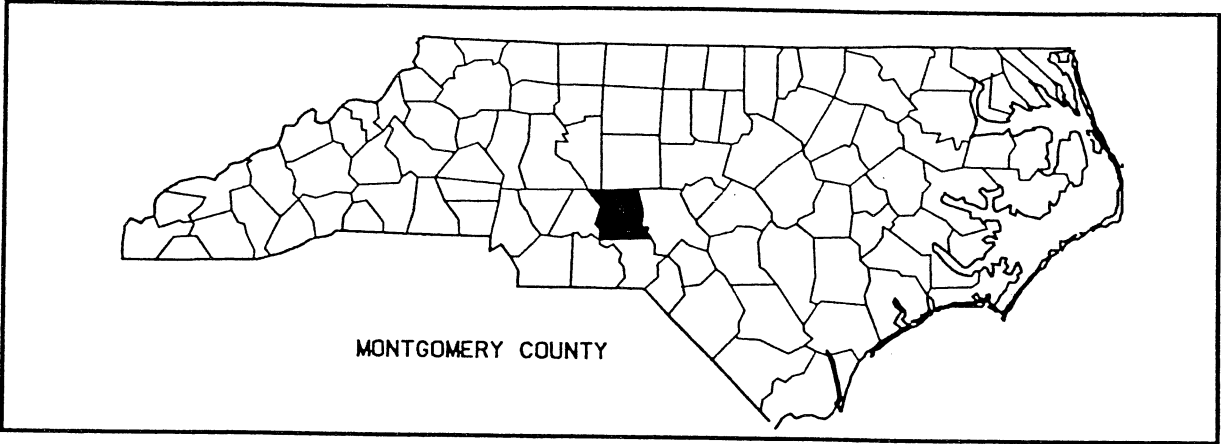

VICINITY MAPS

N. C. DEPT. OF TRANSPORTATION
DIVISION OF HIGHWAYS
MONTGOMERY COUNTY
PROJECT: 8.T550803 (R-2231CB)

US 220 BYPASS

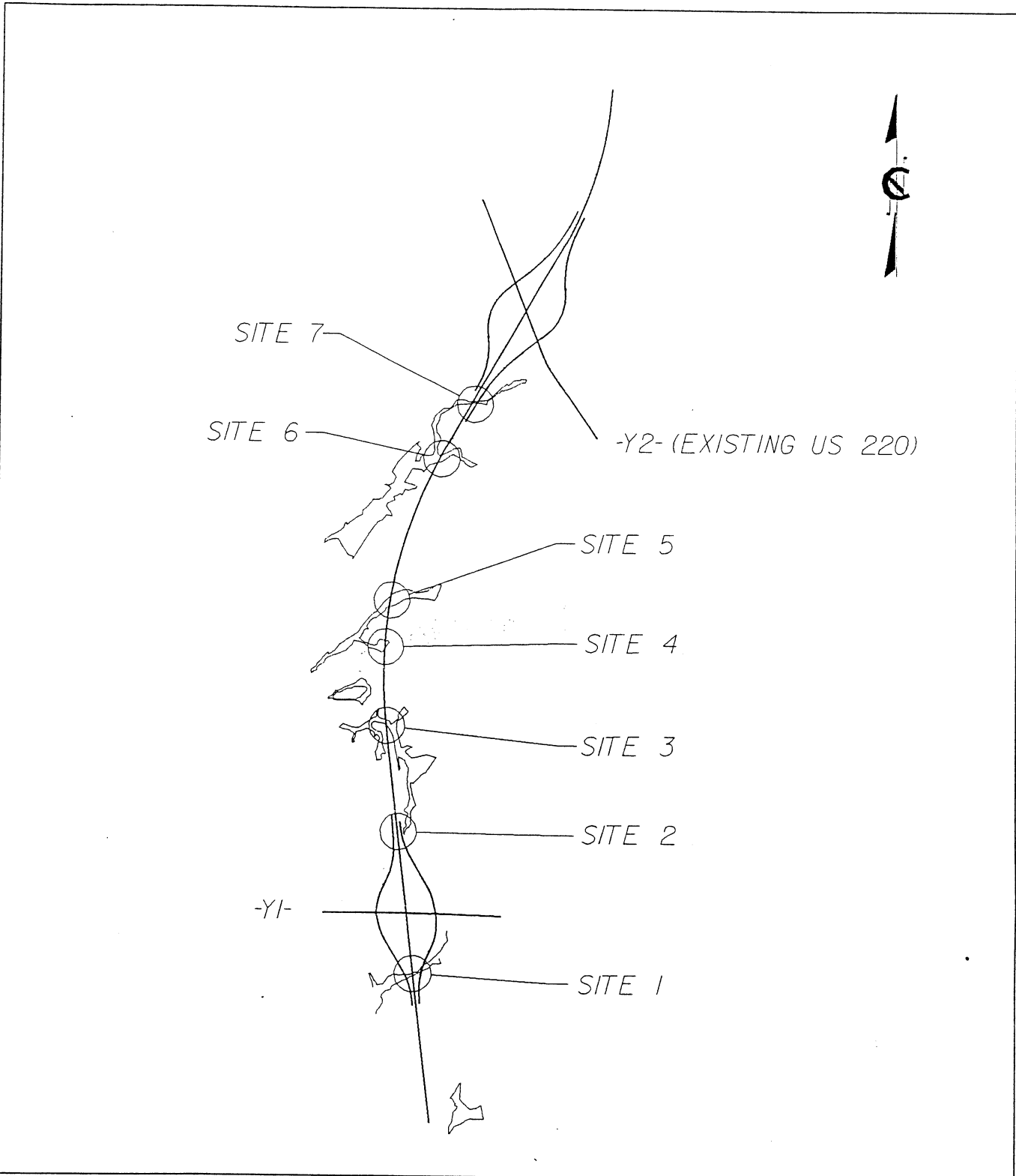









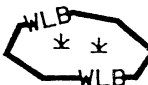



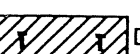

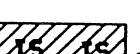
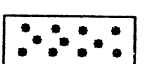



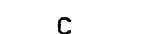



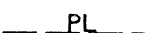



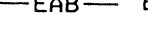
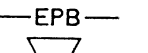

SITE MAP

N. C. DEPT. OF TRANSPORTATION
 DIVISION OF HIGHWAYS
 MONTGOMERY COUNTY
 PROJECT: 8.T550803 (R-2231CB)

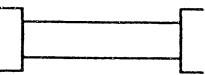
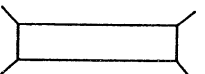
US 220 BYPASS

LEGEND

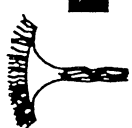
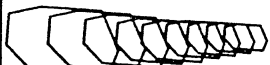
-  WETLAND BOUNDARY
-  WETLAND
-  DENOTES FILL IN WETLAND
-  DENOTES FILL IN SURFACE WATER
-  DENOTES FILL IN SURFACE WATER (POND)
-  DENOTES TEMPORARY FILL IN WETLAND
-  DENOTES EXCAVATION IN WETLAND
-  DENOTES TEMPORARY FILL IN SURFACE WATER
-  DENOTES MECHANIZED CLEARING
-  FLOW DIRECTION
-  TOP OF BANK
-  EDGE OF WATER
-  PROP. LIMIT OF CUT
-  PROP. LIMIT OF FILL
-  PROP. RIGHT OF WAY
-  NATURAL GROUND
-  PROPERTY LINE
-  TEMP. DRAINAGE EASEMENT
-  PERMANENT DRAINAGE EASEMENT
-  EXIST. ENDANGERED ANIMAL BOUNDARY
-  EXIST. ENDANGERED PLANT BOUNDARY
-  WATER SURFACE

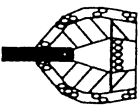
- LIVE STAKES
-  BOULDER
-  COIR FIBER ROLLS
-  ADJACENT PROPERTY OWNER OR PARCEL NUMBER
-  PROPOSED BRIDGE
-  PROPOSED BOX CULVERT
-  PROPOSED PIPE CULVERT
- (DASHED LINES DENOTE EXISTING STRUCTURES)
-  SINGLE TREE
- WOODS LINE
-  DRAINAGE INLET
-  ROOTWAD
-  VANE
-  RIP RAP
-  RIP RAP ENERGY DISSIPATOR BASIN

N. C. DEPT. OF TRANSPORTATION
DIVISION OF HIGHWAYS

MONTGOMERY COUNTY

PROJECT: 8.T550803

SHEET 3 OF 35 9/02

PROPERTY OWNERS

NAMES AND ADDRESSES

PARCEL NO.	NAMES	ADDRESSES
1	STANLY RICHMOND & CO.	PO BOX 1267 ROCKINGHAM, NC 27379
2	GERALD L. FERGUSON	BOX 64 WILLIARD, KY 41181
3	CLIFTON BAKER	482 SURRETT RD. DENTON, NC 27239
4	ROBERT D. JOHNSON	RT. 2, BOX 42 CANDOR, NC 27229
5	CATAWBA NEWSPRINT CO.	PO BOX 7 CATAWBA, SC 29704
6	NC HIGHWAY DEPARTMENT	
7	CLAUDE W. HICKS	RT3 BOX 342 CANDOR, NC 27229

N. C. DEPT. OF TRANSPORTATION
DIVISION OF HIGHWAYS
MONTGOMERY COUNTY

PROJECT: 8.T550803 (R2231CB)

US 220 BYPASS

SECTION

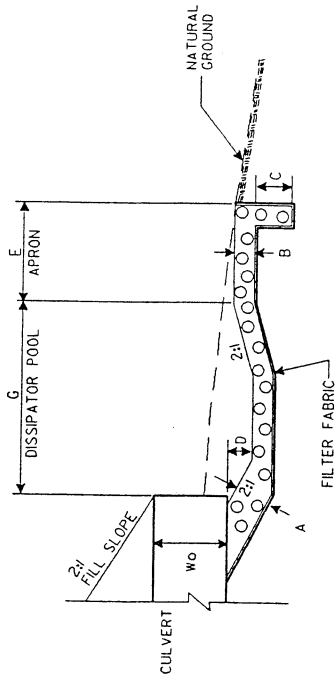

HALF PLAN

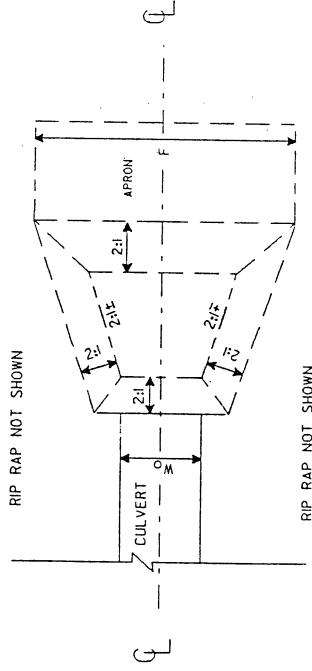

DETAIL OF RIP-RAPPED OUTLET ENERGY DISSIPATOR BASIN

STATE OF NORTH CAROLINA
 DIVISION OF HIGHWAYS
 RALEIGH, N.C.

N. C. DEPT. OF TRANSPORTATION
 DIVISION OF HIGHWAYS
 MONTGOMERY COUNTY
 PROJECT: 8.T550803 (R-2231CB)
 US 220 BYPASS

9/02

PREFORMED SCOUR HOLE

PLAN VIEW

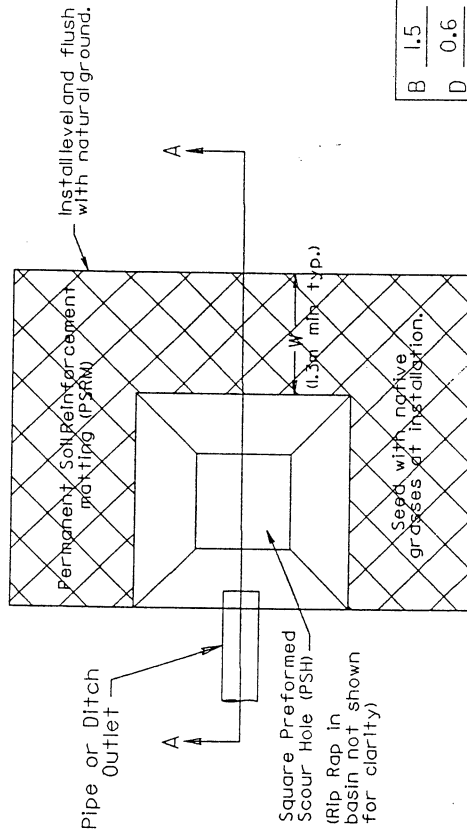

B	1.5
D	0.6
W	2.0
d	0.15

SECTION A-A

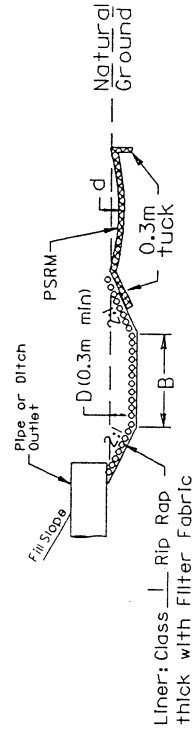

N. C. DEPT. OF TRANSPORTATION
 DIVISION OF HIGHWAYS
 RICHMOND COUNTY
 PROJECT: 8.T550803 (R-2231CB)

US 220 BYPASS

CROSS VANE DETAILS

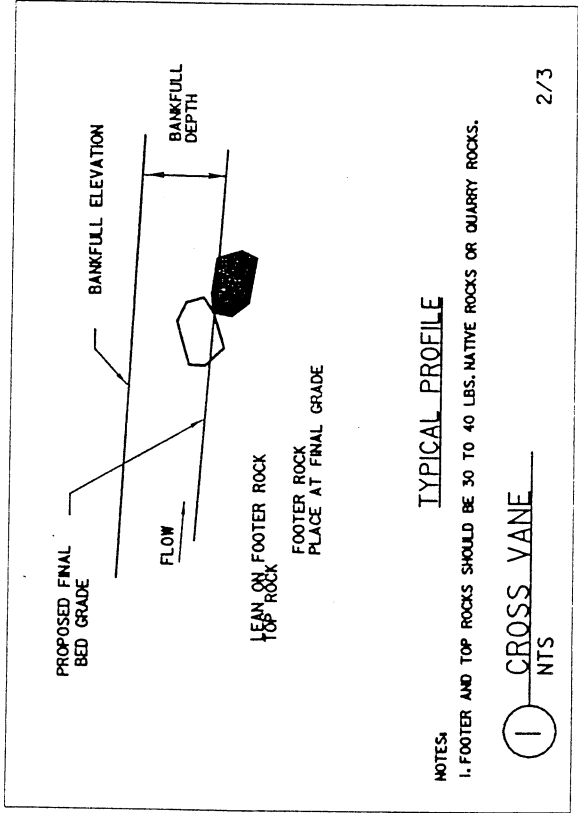
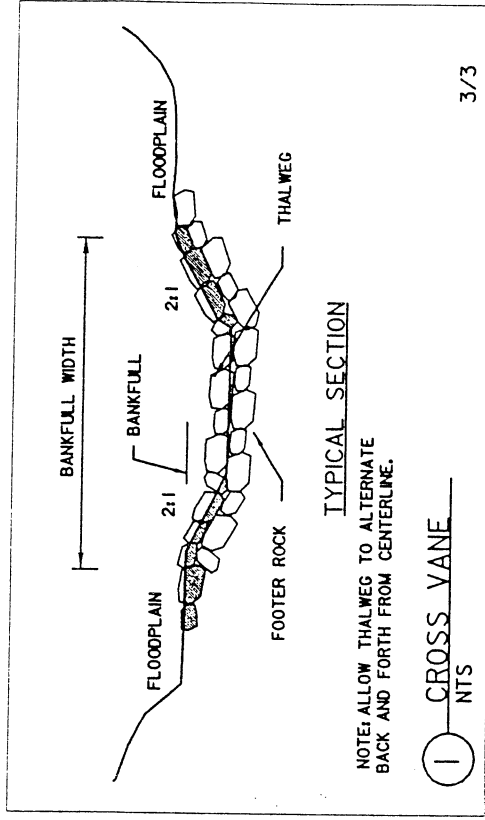
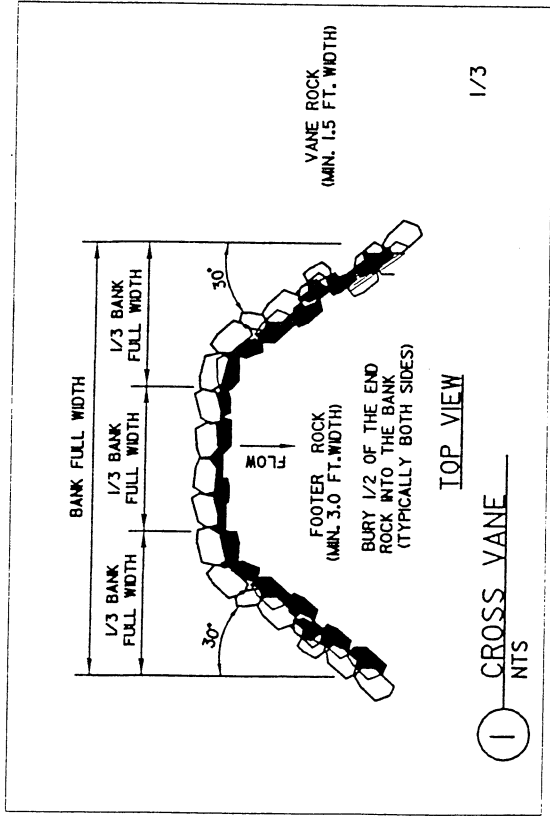

N. C. DEPT. OF TRANSPORTATION
DIVISION OF HIGHWAYS
MONTGOMERY COUNTY

PROJECT: 8.T550803 (R-2231CB)

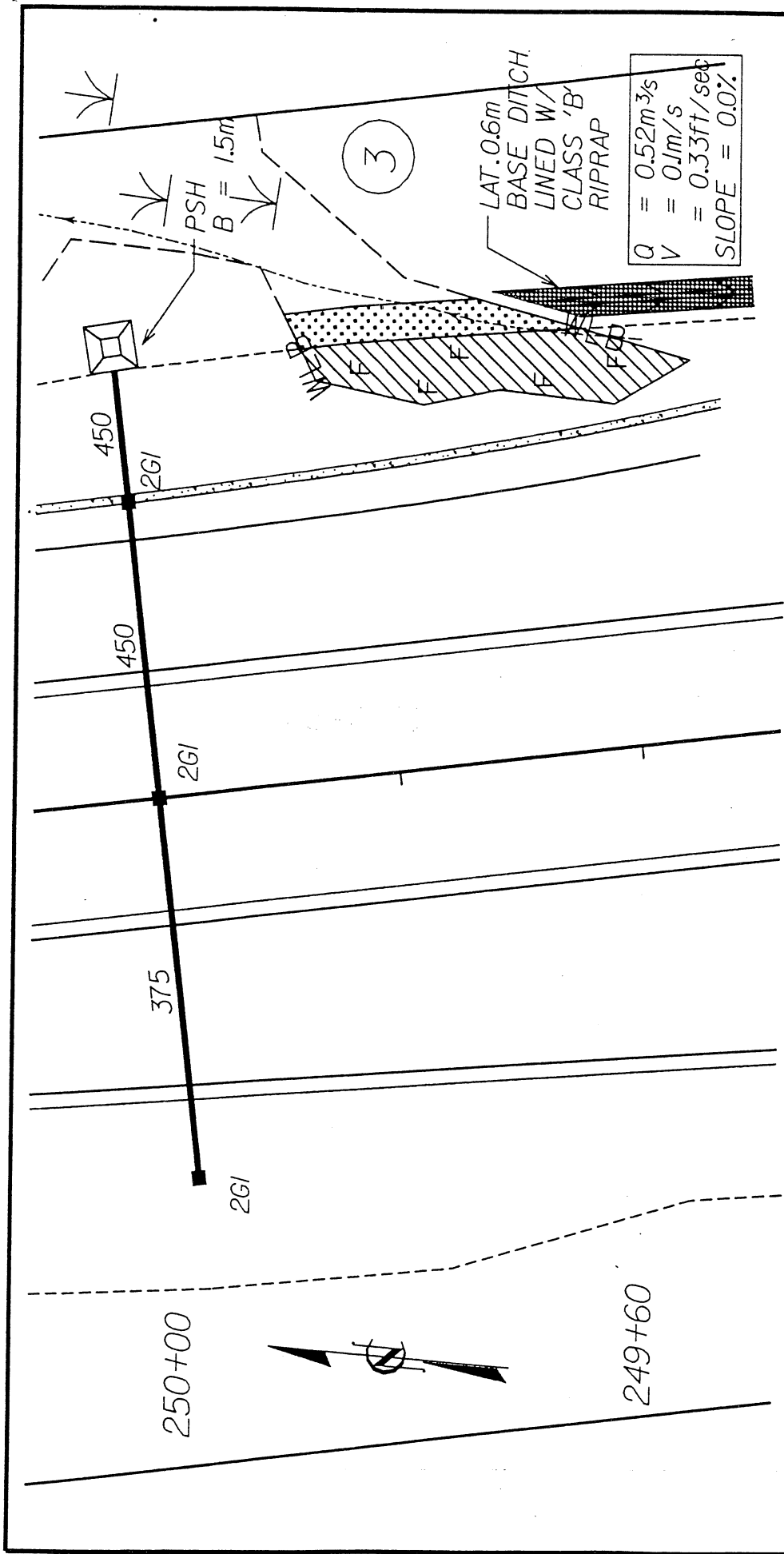

US 220 BYPASS

SHEET 7 OF 35 9/02

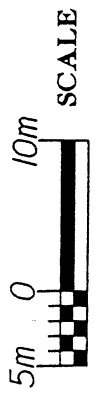

PLAN VIEW
SITE 2

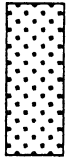

-  DENOTES TEMP. MECHANIZED CLEARING
-  DENOTES FILL IN WETLANDS

N. C. DEPT. OF TRANSPORTATION
DIVISION OF HIGHWAYS
MONTGOMERY COUNTY

PROJECT: 8.T550803 (R2231CB)



US 220 BYPASS



PLAN VIEW

SITE 3

(SHEET 1 OF 2)

-  DENOTES MECHANIZED CLEARING
-  DENOTES EXCAVATION IN SURFACE WATERS
-  DENOTES FILL IN WETLANDS

N. C. DEPT. OF TRANSPORTATION
 DIVISION OF HIGHWAYS
 MONTGOMERY COUNTY
 PROJECT: 8.T550805 (R-2231CB)

US 220 BYPASS

SHEET 10 OF 35 REVISED 9 / 02

MATCHLINE STA. 254 + 00 -L-
 MATCH SITE 3 (SHEET 2 OF 2)

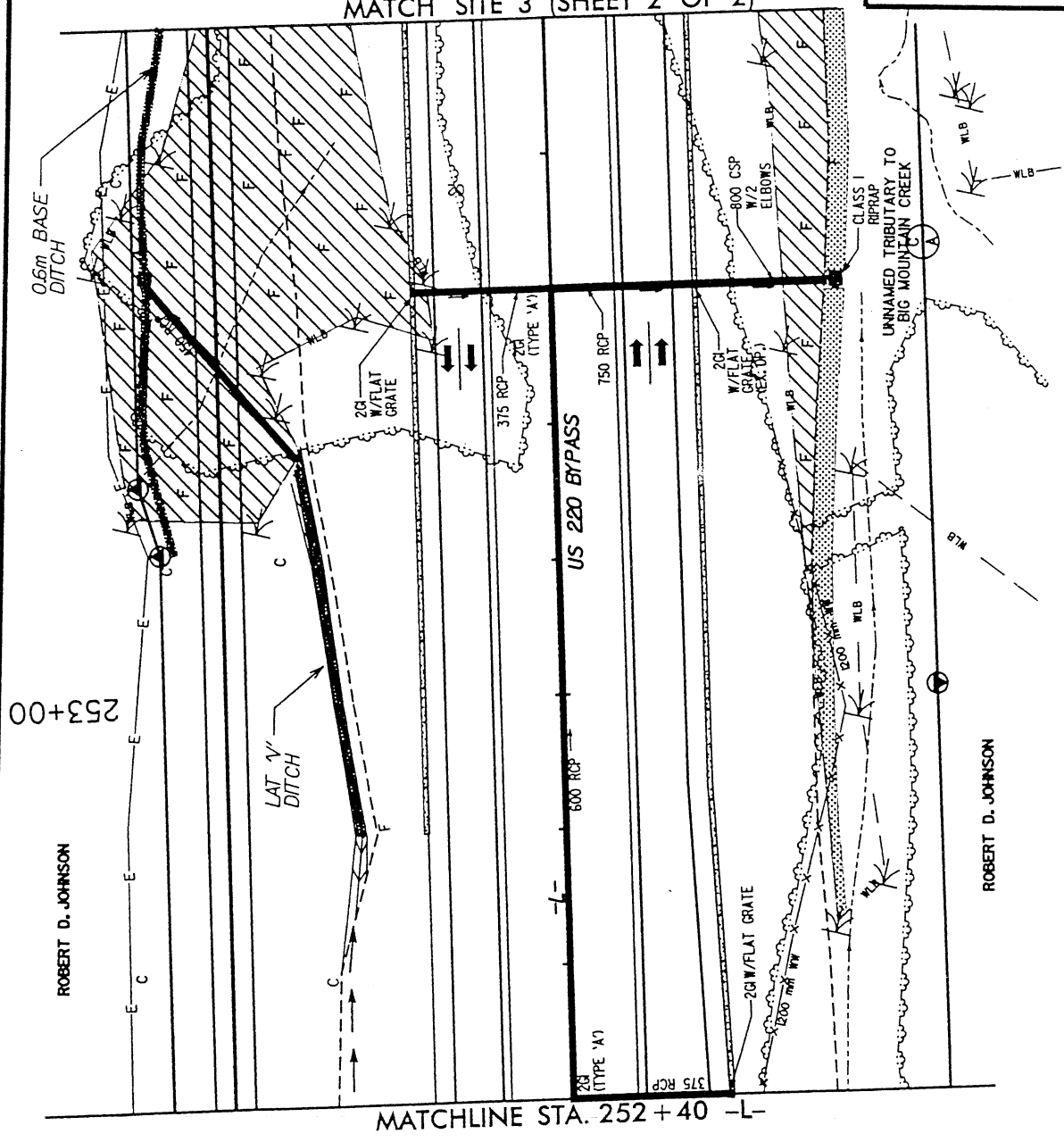

ROBERT D. JOHNSON

ROBERT D. JOHNSON

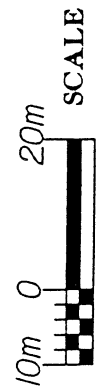

MATCHLINE STA. 252 + 40 -L-



PLAN VIEW

SITE 3 (SHEET 2 OF 2)



DENOTES MECHANIZED
CLEARING

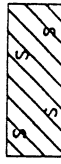

DENOTES FILL
IN SURFACE WATERS

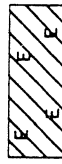

DENOTES EXCAVATION
IN WETLANDS

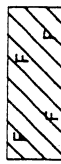

DENOTES FILL
IN WETLANDS

N. C. DEPT. OF TRANSPORTATION
DIVISION OF HIGHWAYS
MONTGOMERY COUNTY

PROJECT: 8.T550803 (R-2231CB)

US 220 BYPASS

SHEET 11 OF 35 REV. 9/02

MATCHLINE STA. 255 + 80 -L-

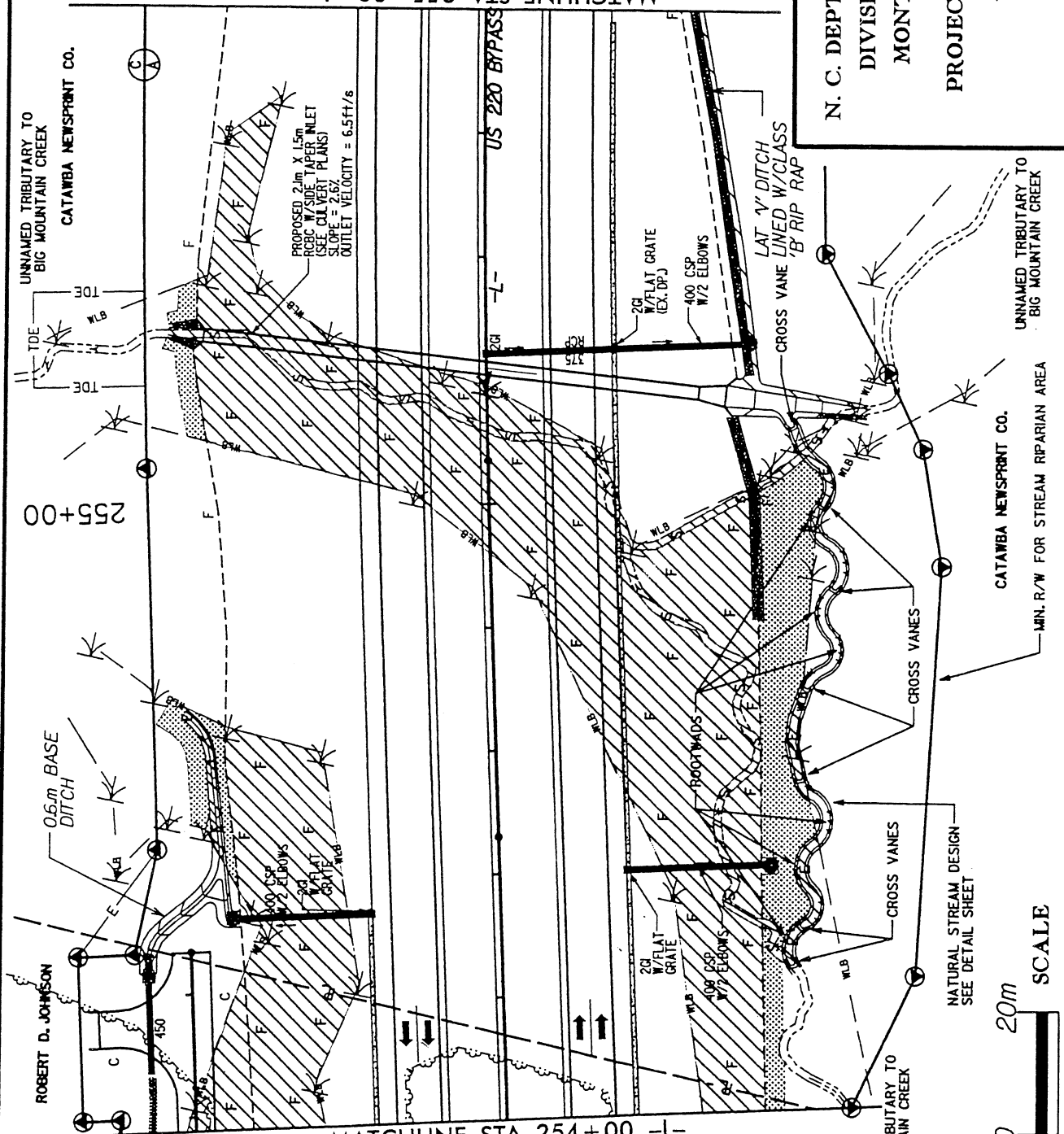

UNNAMED TRIBUTARY TO
BIG MOUNTAIN CREEK

CATAWBA NEWSPRINT CO.

255+00

0.6m. BASE
DITCH

ROBERT D. JOHNSON

MATCHLINE STA. 254 + 00 -L-
MATCH SITE 3 (SHEET 1 OF 2)

US 220 BYPASS

20' W/FLAT
GRATE
(EX. DPJ)

400' CSP
W/2 ELBOWS

LAT. V' DITCH
LINED W/CLASS
'B' RIP RAP

CROSS VANE
LINED W/CLASS
'B' RIP RAP

CROSS VANES

CROSS VANES

CROSS VANES

NATURAL STREAM DESIGN
SEE DETAIL SHEET

CATAWBA NEWSPRINT CO.

MIN. R/W FOR STREAM RIPARIAN AREA

UNNAMED TRIBUTARY TO
BIG MOUNTAIN CREEK

10m 0 20m

SCALE



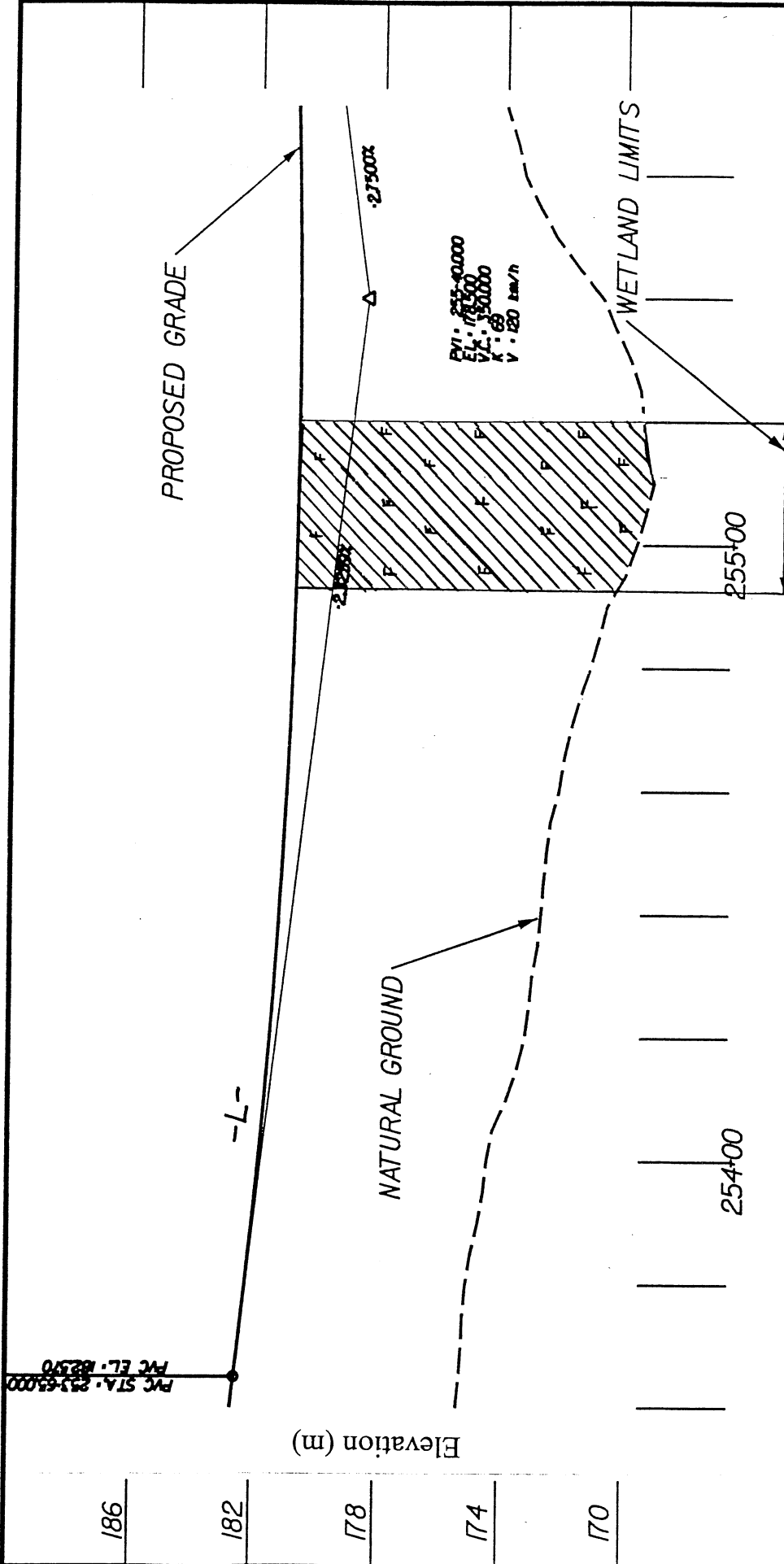

PROFILE SITE 3

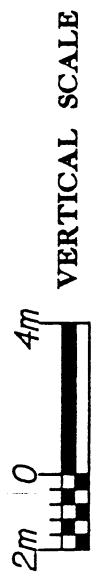

DENOTES FILL
IN WETLANDS

N. C. DEPT. OF TRANSPORTATION
DIVISION OF HIGHWAYS
MONTGOMERY COUNTY
PROJECT: 8.T550803 (R-2231CB)

US 220 BYPASS

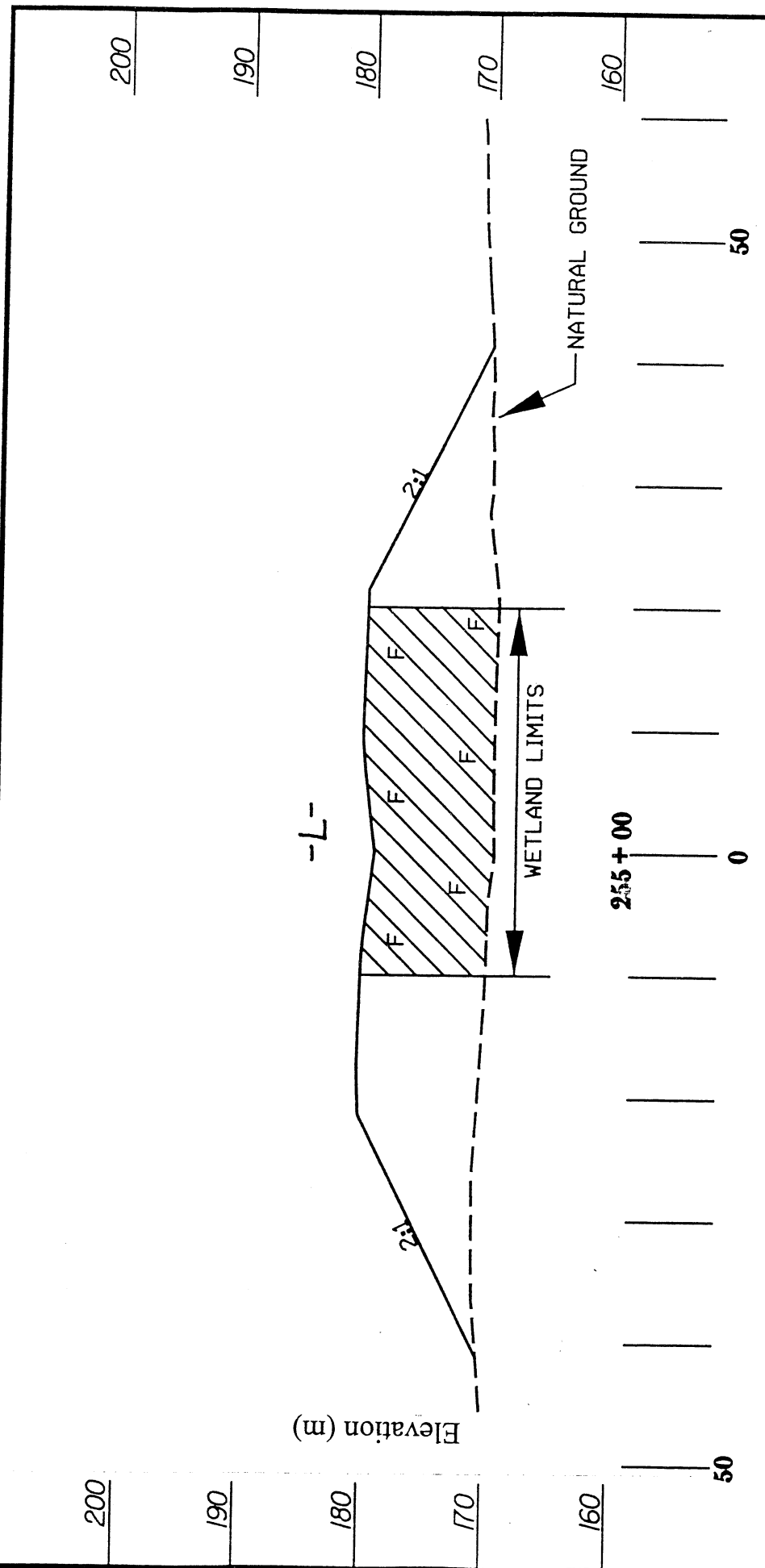

SITE 3 CROSS SECTION

N. C. DEPT. OF TRANSPORTATION
 DIVISION OF HIGHWAYS
 MONTGOMERY COUNTY
 PROJECT: 8.T550803 CR-2231CB
 US 220 BYPASS



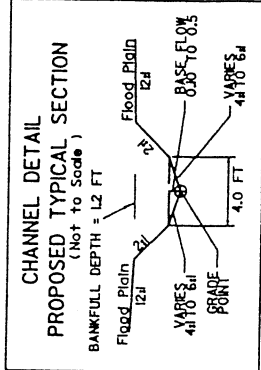
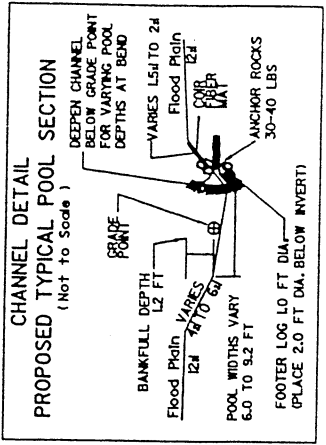
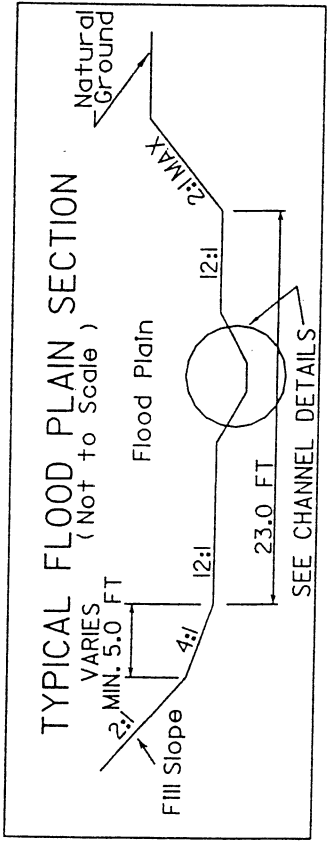

TYPICAL SECTION 2 AT BENDS

TYPICAL SECTION 1 BETWEEN BENDS

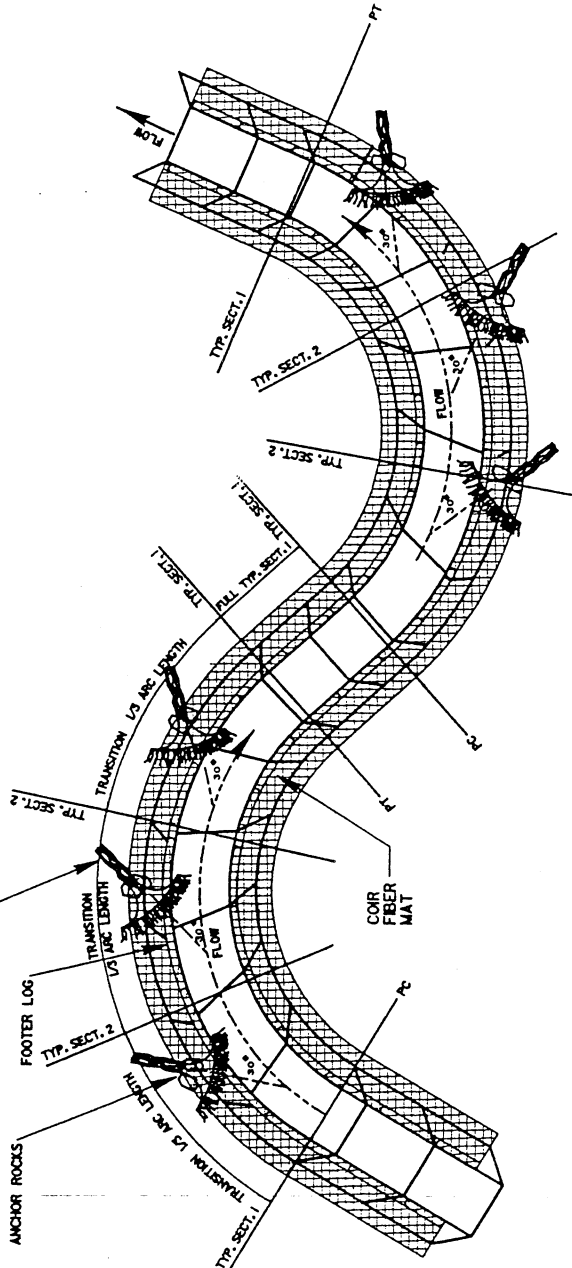

NOTES:
 NUMBER OF ROOTWADS INSTALLED TO BE DETERMINED ON SITE
 ROOTWADS TO BE SPACED 4x DIAMETER OF ROOT BASE
 FOOTER LOG ANCHOR ROCK TO BE PLACED ON THE DOWNSTREAM END
 OF EACH FOOTER LOG SO THAT IT IS LEANING AGAINST THE LOG ON
 THE SIDE AWAY FROM THE CHANNEL.
 WHEN BACKFILLING OVER AND AROUND FOOTER LOGS, ROOTWAD LOGS
 AND ANCHOR ROCKS FIRMLY SECURE ALL COMPONENTS INCLUDING
 JOINTS, CONNECTIONS AND GAPS.

N. C. DEPT. OF TRANSPORTATION
 DIVISION OF HIGHWAYS
 MONTGOMERY COUNTY

PROJECT: 8.T550803 (R-2231CB)

US 220 BYPASS

CHANNEL PLAN VIEW
 SITE 3

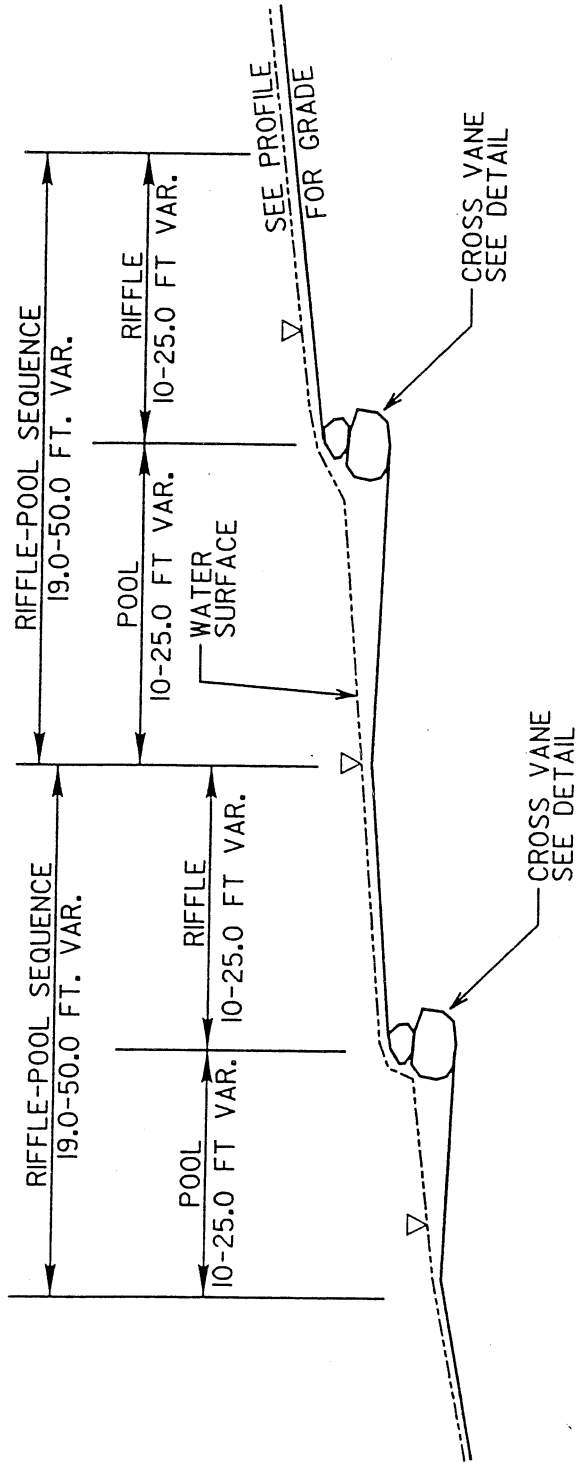

RIFLE-POOL SPACING SITE 3

NOT TO SCALE

N. C. DEPT. OF TRANSPORTATION
DIVISION OF HIGHWAYS
MONTGOMERY COUNTY

PROJECT: 8.T550803 (R-2231CB)

US 220 BYPASS

**Morphological Measurement Table for R-2231CB
Stream @ Site 3**

Variables	Existing Channel	Proposed Reach	USGS Station	Reference Reach Existing Stream
1. Stream type(Rosgen Classification)	E5	E5	na	E5
2. Drainage area (Ac)	109	109	na	109
3. Bankfull width (FT)	6.9	7.5	na	6.9
4. Bankfull mean depth (FT)	0.65	0.65	na	0.65
5. Width/depth ratio	10.5	11.5	na	10.5
6. Bankfull cross-sectional area (FT^3)	14.8	15.9	na	14.8
7. Bankfull mean velocity (FT/s)	3.3	3.3	na	3.3
8. Bankfull discharge, cfs	12.4	12.4	na	12.4
9. Bankfull max depth (riffle)	1.2	1.2	na	1.2
10. Width of floodprone area (FT)	25	24	na	25
11. Entrenchment ratio	3.6	3.2	na	3.6
12. Meander length (FT)	52	44	na	52
13. Ratio of meander length to bankfull width	7.6	5.9	na	7.6
14. Radius of curvature (FT)	13	15.4	na	13
15. Ratio of radius of curvature to bankfull width	1.9	2.05	na	1.9
16. Belt width (FT)	11.5	11.5	na	11.5
17. Meander width ratio	1.67	1.52	na	1.7
18. Sinuosity (stream length/valley length)	1.23	1.25	na	1.2
19. Valley slope (FT/FT)	0.0122	0.0122	na	0.0122
20. Average slope valley slope/sinuosity	0.0099	0.0098	na	0.0099
21. Pool slope (FT/FT)	0.005	0.005	na	0.005
22. Ratio of pool slope to average slope	0.54	0.54	na	0.54
23. Maximum pool depth (FT)	2.2	2.2	na	2.2
24. Ratio of pool depth to average bankfull depth	3.3	3.3	na	3.3
25. Pool width(FT)	6.2-8.2	6.2-9.2	na	6.2-8.2
26. Ratio of pool width to bankfull width	0.9-1.19	0.83-1.22	na	0.9-1.2
27. Pool to pool spacing (FT)	6-15	6-18	na	15-Jun
28. Ratio of pool to pool spacing to bankfull width	2.85-7.1	2.6-7.8	na	2.85-7.1

NCDOT Project ID# R-2231CB
Montgomery County
US 220 Bypass from south of SR 1524 to
Existing four-lane section of US 220, North of US 220 alternate

Prepared by: Sungate Design Group, PA
915-A Jones Franklin Road
Raleigh, NC 27606

April 13, 2001

NATURAL CHANNEL DESIGN RIGHT OF STA. 254+60 -L-

The proposed new location US 220 will cause a shift in the existing stream at +/- 254+60 -L-. The existing and proposed channels were classified according to principles proposed by Dave Rosgen.

The existing stream drains 44 Ha (109 Acres) of a rural agricultural area. The first order perennial stream drains an existing pastureland into a hardwood forest at the point of relocation. The channel was found to be perennial with riffles, pools, and aquatic wildlife.

There are no hydraulic gage data available on this stream nor on nearby streams. Current discharges were estimated using NCDOT procedures for rural watersheds and calibrated to the field observed bankfull depth.

The existing channel is relatively stable in the hardwood forest and has pattern and dimension. The data gathered was used to classify the reach to be relocated as an E5 stream according to the Rosgen classification procedure.

Because of the development in the present climatic era, a reference reach of a **stable** stream in this area is unlikely. A portion upstream of the site and at the site was used as a representative reach to reference pattern and dimension. The portion used for a reference was found to have characteristics of an E5 stream. The dimensions gathered in the field compared favorably to the regional curves developed by the North Carolina Stream Restoration Institute. Using these reference characteristics and the regional curves Sungate Design has recommended a natural stream design by replacing the existing E5 channel with a stable E5 channel.

Bankfull mean depth was found to be 0.2m (0.7 ft). With this information a proposed channel was designed to maintain a low width/depth ratio and a high entrenchment ratio. Sinuosity was increased slightly, as well as, the radius of curvature. These modifications will encourage a decrease of energy along the channel banks.

A pebble count was conducted in the pools and riffles. Velocities were obtained using standard engineering procedures. These velocities were compared to shear stresses predicted by the pebble count. The pebble count confirmed the channel hydraulics by qualifying the velocities that have moved bed form material. This material has been classified as a fine to medium sand. The proposed channel was designed to maintain velocities and appropriate shear stress that will transport this type of material at bankfull stage without aggrading or degrading the stream banks or bed.

The proposed channel utilizes cross vanes and root wads to direct flow away from the banks and help create pools and riffles to encouraged aquatic habitat. Finally, native woody vegetation will be used to stabilize the proposed flood plain and channel banks.

PEBBLE COUNT								
Site: Trib. To Big Mountain Crk. +/-254+60-L- R-2231CB						Date: 4-05-01		
Party: WHW,FFF,RHK								
Particle Counts								
Inches	Particle	Millimeter		Riffles	Pools	Total No.	Item %	% Cumulative
	Silt/Clay	< 0.062	S/C	16	0	16	16%	16%
.04 - .08	Very Fine	.062 - .125	S	36	0	36	36%	52%
	Fine	.125 - .25	A	28	0	28	28%	80%
	Medium	.25 - .50	N	8	0	8	8%	88%
	Coarse	.50 - 1.0	D	12	0	12	12%	100%
	Very Coarse	1.0 - 2.0	S	0	0	0	0%	100%
.08 - .16	Very Fine	2.0 - 4.0		0	0	0	0%	100%
.16 - .22	Fine	4.0 - 5.7	G	0	0	0	0%	100%
.22 - .31	Fine	5.7 - 8.0	R	0	0	0	0%	100%
.31 - .44	Medium	8.0 - 11.3	A	0	0	0	0%	100%
.44 - .63	Medium	11.3 - 16.0	V	0	0	0	0%	100%
.63 - .89	Coarse	16.0 - 22.6	E	0	0	0	0%	100%
.89 - 1.26	Coarse	22.6 - 32.0	L	0	0	0	0%	100%
1.26 - 1.77	Very Coarse	32.0 - 45.0	S	0	0	0	0%	100%
1.77 - 2.5	Very Coarse	45.0 - 64.0		0	0	0	0%	100%
2.5 - 3.5	Small	64 - 90	C	0	0	0	0%	100%
3.5 - 5.0	Small	90 - 128	O	0	0	0	0%	100%
5.0 - 7.1	Large	128 - 180	B	0	0	0	0%	100%
7.1 - 10.1	Large	180 - 256	L	0	0	0	0%	100%
10.1 - 14.3	Small	256 - 362	B	0	0	0	0%	100%
14.3 - 20	Small	362 - 512	L	0	0	0	0%	100%
20 - 40	Medium	512 - 1024	D	0	0	0	0%	100%
40 - 80	Lrg- Very Lrg	1024 - 2048	R	0	0	0	0%	100%
	Bedrock		BDRK	0	0	0	0%	100%
Totals				100	0	100	100%	100%

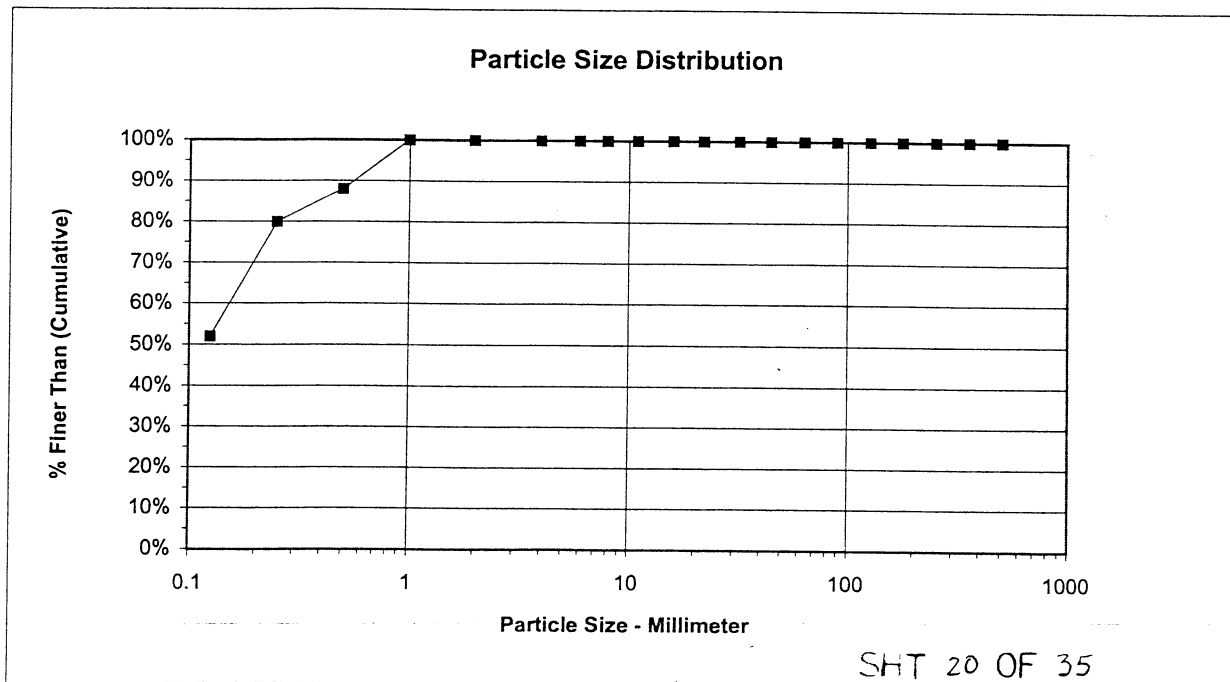

171.58	10+000
171.66	10+03.1
171.51	10+03.8
171.58	10+04.5
171.56	10+05.1
171.47	10+06.8
171.62	10+09.2
171.50	10+09.8
171.56	10+11.2
171.52	10+13.4
171.54	10+14.7
171.20	10+15.7
171.49	10+17.6
171.24	10+19.8
171.32	10+22.8
171.23	10+24.0
171.34	10+26.5
171.13	10+29.3
171.17	10+30.7
171.22	10+32.8

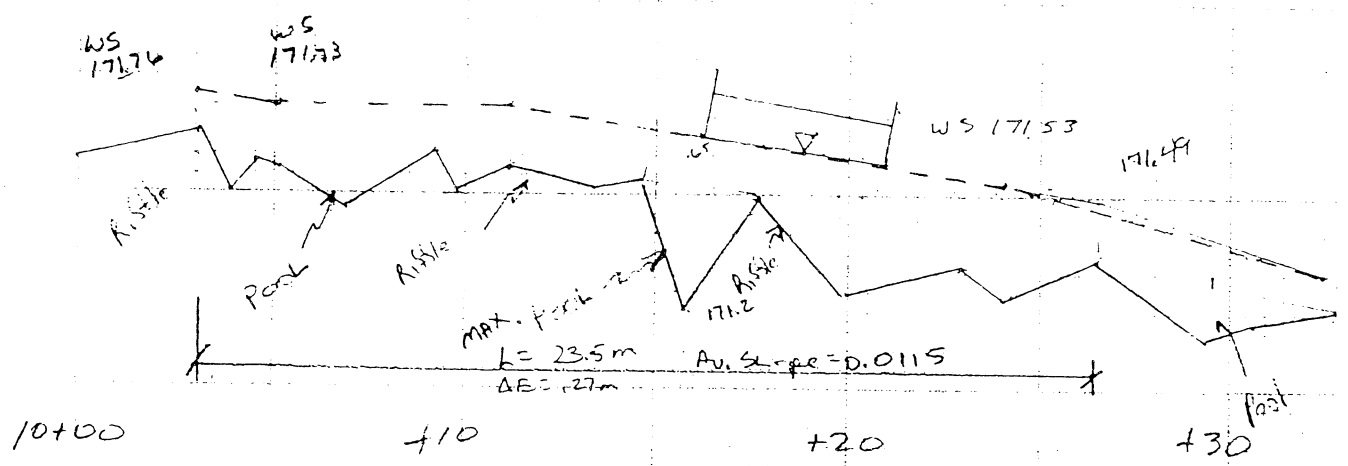

Existing (Theory) THAIL PROFILE NEAR -BL- # 74
 (Reference)

± 254 +60 -L- LT.

PLAN VIEW SITE 5

UNNAMED TRIBUTARY TO
BIG MOUNTAIN CREEK

EXISTING 0.9M BASE CHANNEL
W/1/1 SIDES

CLASS '1'
RIP RAP

260+00

261+40

SLOPE = 2.3%
VELOCITY = 1.64m/sec
VELOCITY = 5.4ft/sec

DENOTES FILL IN WETLANDS

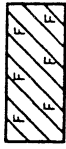

DENOTES FILL IN SURFACE WATERS

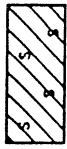

DENOTES MECHANIZED CLEARING



N. C. DEPT. OF TRANSPORTATION
DIVISION OF HIGHWAYS
MONTGOMERY COUNTY

PROJECT: 8.T550803 (R2931CB)

US220 BYPASS

SHEET 22 OF 35 REV 9/02

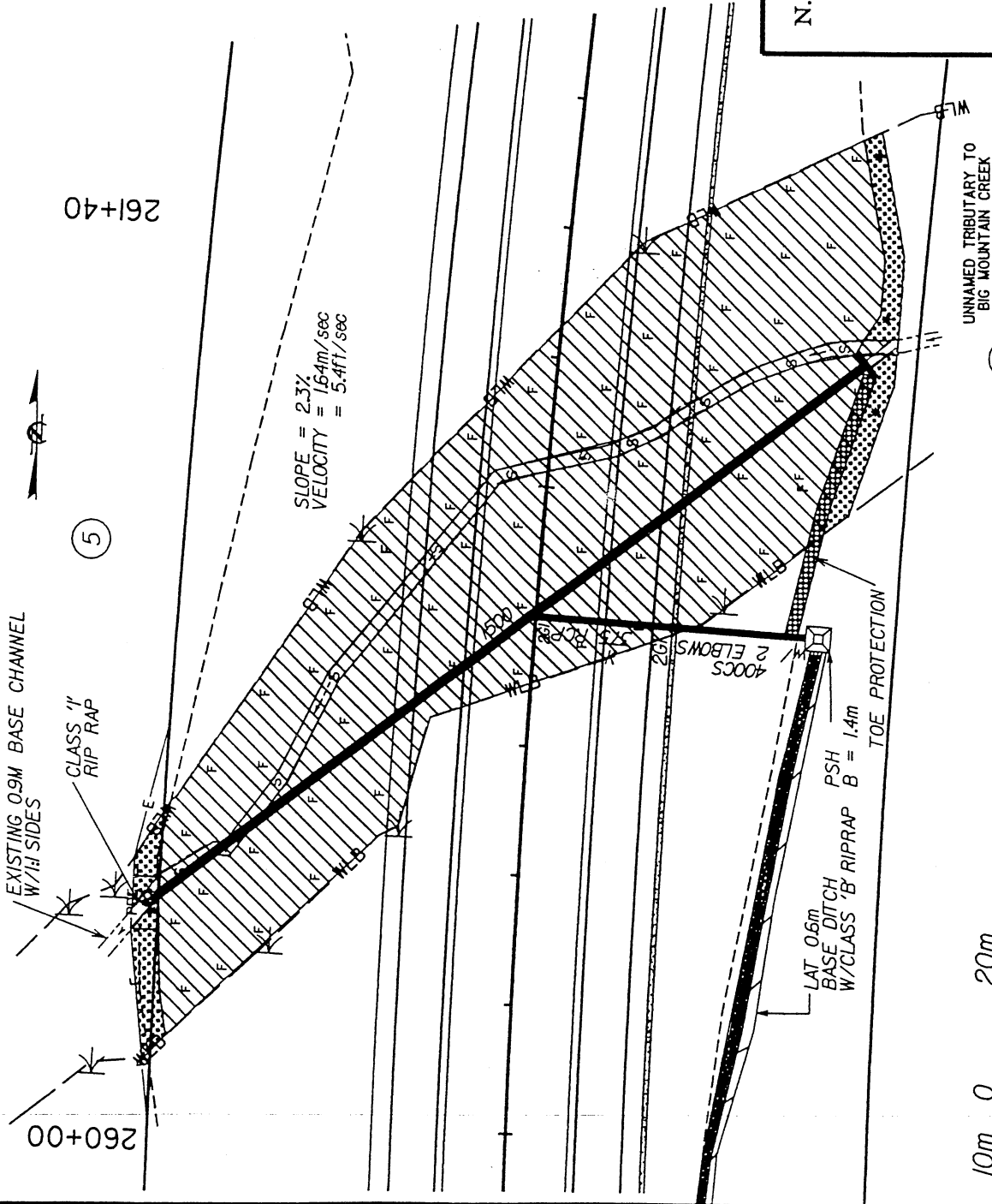

UNNAMED TRIBUTARY TO
BIG MOUNTAIN CREEK

5

10m 0 20m

SCALE



5

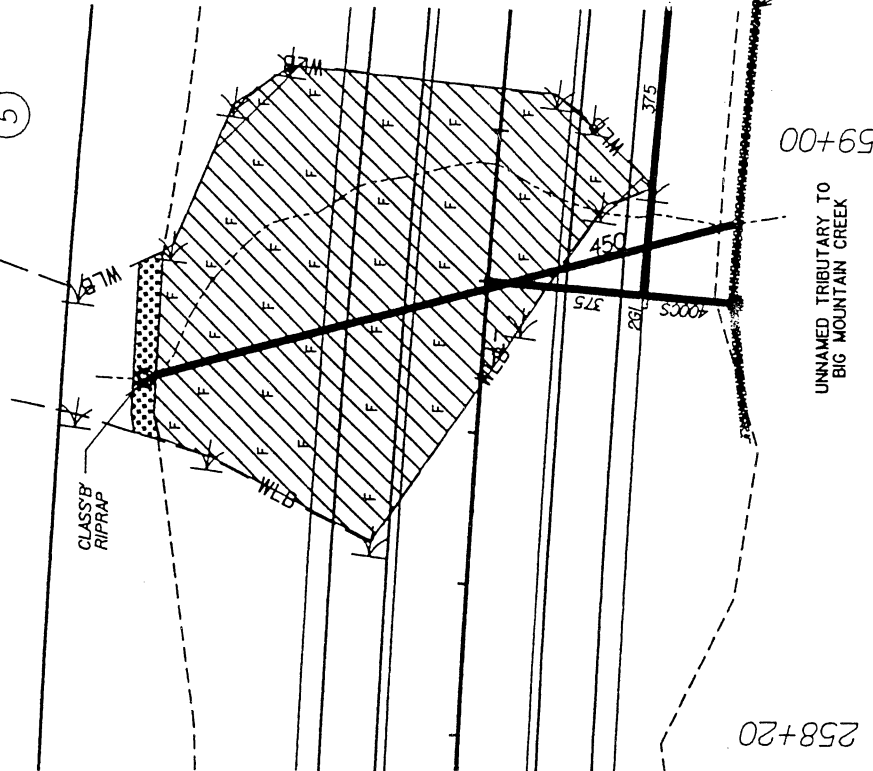

SLOPE = 6.8%
 VELOCITY = 0.82m/sec
 = 27ft/sec

PLAN VIEW SITE 4

N. C. DEPT. OF TRANSPORTATION
 DIVISION OF HIGHWAYS
 MONTGOMERY COUNTY
 PROJECT: 8.T550803 (R2231CB)

US 220 BYPASS

SHEET 21 OF 35 REV. 9/02

 DENOTES MECHANIZED CLEARING

 DENOTES FILL IN WETLANDS

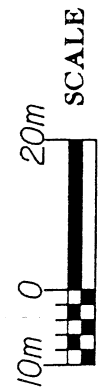

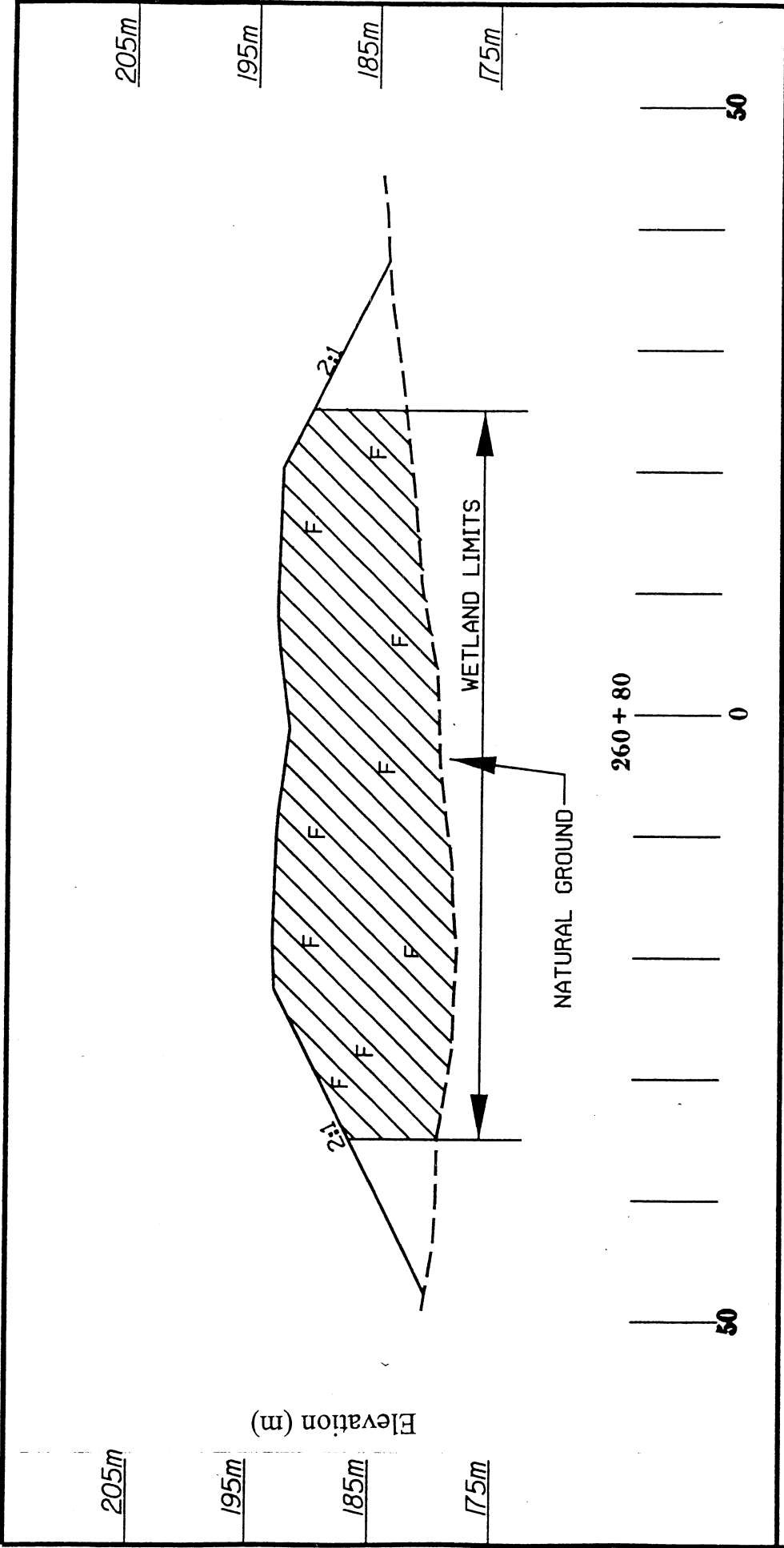

N. C. DEPT. OF TRANSPORTATION
 DIVISION OF HIGHWAYS
 MONTGOMERY COUNTY
 PROJECT: 8.T550803 (R-2231CB)
 US 220 BYPASS

SHEET 24 OF 35 9/02

SITE 5 CROSS SECTION

HORIZONTAL SCALE

VERTICAL SCALE

DENOTES FILL
IN WETLANDS

PROPOSED GRADE

NATURAL GROUND

WETLAND LIMITS

261+00

260+00

Elevation (m)

194

190

186

182

178

PROFILE SITE 5

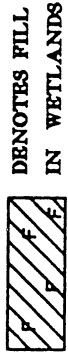
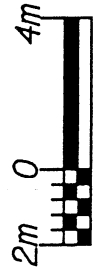

N. C. DEPT. OF TRANSPORTATION
 DIVISION OF HIGHWAYS
 MONTGOMERY COUNTY
 PROJECT: 8.T550803 (R-2231CB)

US220 BYPASS

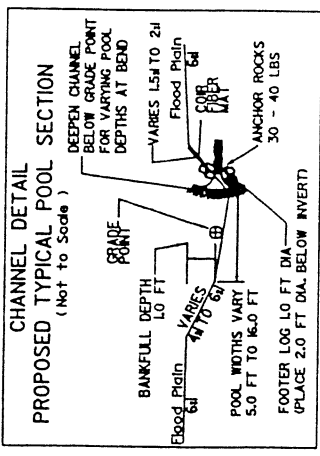
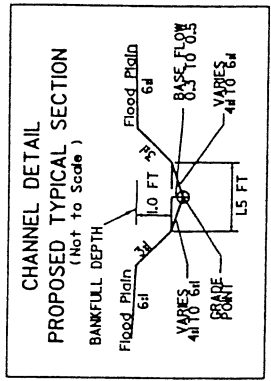
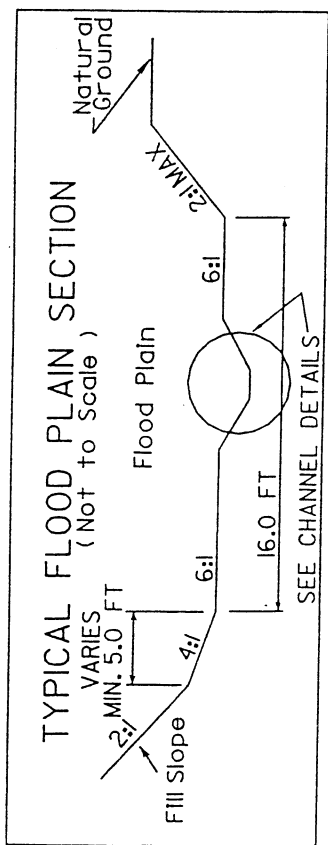

TYPICAL SECTION 2 AT BENDS

TYPICAL SECTION 1 BETWEEN BENDS

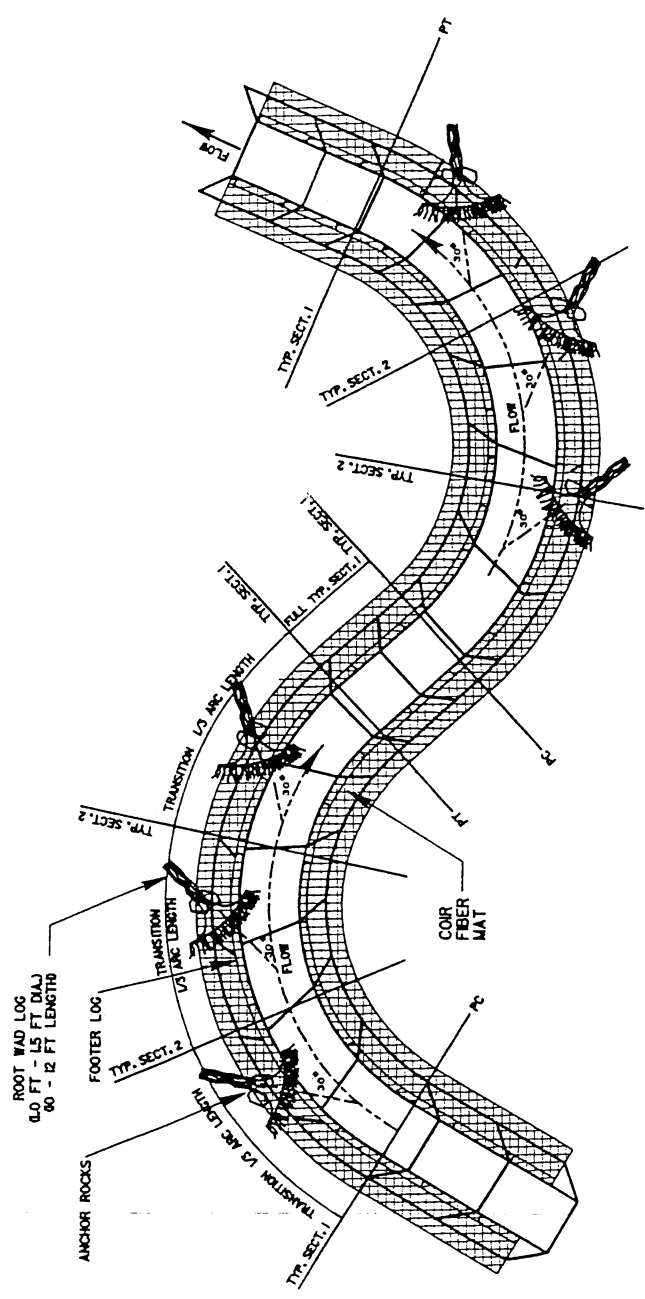

NOTES:
NUMBER OF ROOTWADS INSTALLED TO BE DETERMINED ON SITE
ROOTWADS TO BE SPACED 4X DIAMETER OF ROOT BASE
FOOTER LOG ANCHOR ROCK TO BE PLACED ON THE DOWNSTREAM END
OF EACH FOOTER LOG SO THAT IT IS LEANING AGAINST THE LOG ON
THE SIDE AWAY FROM THE CHANNEL.
WHEN BACKFILLING OVER AND AROUND FOOTER LOGS, ROOTWAD LOGS
AND ANCHOR ROCKS FIRMLY SECURE ALL COMPONENTS INCLUDING
JOINTS, CONNECTIONS AND GAPS.

N. C. DEPT. OF TRANSPORTATION
DIVISION OF HIGHWAYS
MONTGOMERY COUNTY

PROJECT: 8.T550803 (R-2231CB)

US 220 BYPASS

CHANNEL PLAN VIEW
SITE 6

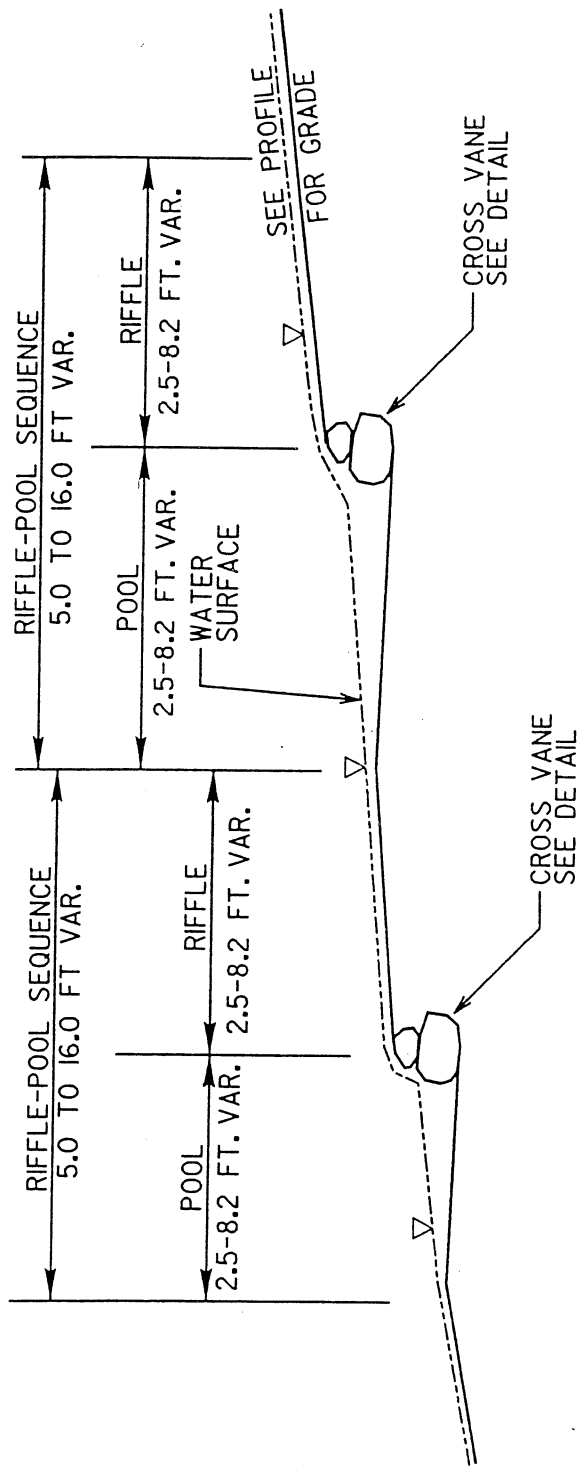

RIFFLE-POOL SPACING SITE 6

NOT TO SCALE

N. C. DEPT. OF TRANSPORTATION
DIVISION OF HIGHWAYS
MONTGOMERY COUNTY

PROJECT: 8.T550803 (R-2231CB)

US 220 BYPASS

**Morphological Measurement Table for R-2231CB
Stream @ Site 6**

Variables	Existing Channel	Proposed Reach	USGS Station	Reference Reach Stream @ Site #3
1. Stream type(Rosgen Classification)	E5	E5	na	E5
2. Drainage area (Ac)	74	74	na	109
3. Bankfull width (FT)	5.9	6.5	na	6.9
4. Bankfull mean depth (FT)	0.69	0.6	na	0.65
5. Width/depth ratio	8.6	10.8	na	10.5
6. Bankfull cross-sectional area (FT ³)	13.1	13.4	na	14.8
7. Bankfull mean velocity (FT/s)	2.8	2.8	na	3.3
8. Bankfull discharge, cfs	11	11.3	na	12.4
9. Bankfull max depth (riffle)	1	1	na	1.2
10. Width of floodprone area (FT)	13.8	16.4	na	25
11. Entrenchment ratio	2.3	2.4	na	3.6
12. Meander length (FT)	28	44	na	52
13. Ratio of meander length to bankfull width	4.7	6.8	na	7.6
14. Radius of curvature (FT)	8.2	10	na	13
15. Ratio of radius of curvature to bankfull width	1.35	1.5	na	1.9
16. Belt width (FT)	9.8	11	na	11.5
17. Meander width ratio	1.7	1.7	na	1.7
18. Sinuosity (stream length/valley length)	1.4	1.4	na	1.2
19. Valley slope (FT/FT)	0.0125	0.0125	na	0.0122
20. Average slope valley slope/sinuosity	0.0086	0.0096	na	0.0099
21. Pool slope (FT/FT)	0.005	0.005	na	0.005
22. Ratio of pool slope to average slope	0.58	0.52	na	0.54
23. Maximum pool depth (FT)	1.3	1.3	na	2.2
24. Ratio of pool depth to average bankfull depth	1.9	2.2	na	3.3
25. Pool width(FT)	3.9-10.2	4.9-10.2	na	6.2-8.2
26. Ratio of pool width to bankfull width	0.67-1.7	0.75-1.6	na	0.9-1.2
27. Pool to pool spacing (FT)	3.6-14.8	4.9-16.4	na	15-Jun
28. Ratio of pool to pool spacing to bankfull width	0.61-2.5	0.75-2.5	na	2.85-7.1

NCDOT Project ID# R-2231CB
Montgomery County
US 220 Bypass from south of SR 1524 to
Existing four-lane section of US 220, North of US 220 alternate

Prepared by: Sungate Design Group, PA
915-A Jones Franklin Road
Raleigh, NC 27606

April 13, 2001

NATURAL CHANNEL DESIGN RIGHT OF STA. 268+40 -L-

The proposed new location US 220 will cause a shift in the existing stream at +/- 268+40 -L-. The existing and proposed channels were classified according to principles developed by Dave Rosgen.

The existing stream drains 30 Ha (74 Acres) of a rural hardwood forested area. The first order perennial stream drains an existing hardwood forest at the point of relocation. The channel was found to be perennial with riffles, pools, and aquatic wildlife.

There are no hydraulic gage data available on this stream nor on nearby streams. Current discharges were estimated using NCDOT procedures for rural watersheds and calibrated to the field observed bankfull depth.

The existing channel is relatively stable in the hardwood forest and has pattern and dimension. The data gathered was used to classify the reach to be relocated as an E5 stream according to the Rosgen classification procedure.

Because of the development in the present climatic era, a reference reach of a **stable** stream in this area is unlikely. A portion of the existing stream at station 254+60 -L- was used as a representative reach to reference pattern and dimension. The portion used for a reference was found to have characteristics of an E5 stream. The dimensions gathered in the field compared favorably to the regional curves developed by the North Carolina Stream Restoration Institute. Using these reference characteristics and the regional curves Sungate Design has recommended a natural stream design by replacing the existing E5 channel with a stable E5 channel.

Bankfull mean depth was found to be 0.18m (0.6 ft). With this information a proposed channel was designed to maintain a low width/depth ratio and a high entrenchment ratio. Sinuosity was maintained with an increase in the radius of curvature. These modifications will encourage a decrease of energy along the channel banks.

A pebble count was conducted in the pools and riffles. Velocities were obtained using standard engineering procedures. These velocities were compared to shear stresses predicted by the pebble count. The pebble count confirmed the channel hydraulics by qualifying the velocities that have moved bed form material. This material has been classified as a fine to medium sand. The proposed channel was designed to maintain velocities that will transport this type of material at bankfull stage without aggrading or degrading the stream banks or bed.

The proposed channel utilizes cross vanes and root wads to direct flow away from the banks and help create pools and riffles to encouraged aquatic habitat. Finally, native woody vegetation will be used to stabilize the proposed flood plain and channel banks.

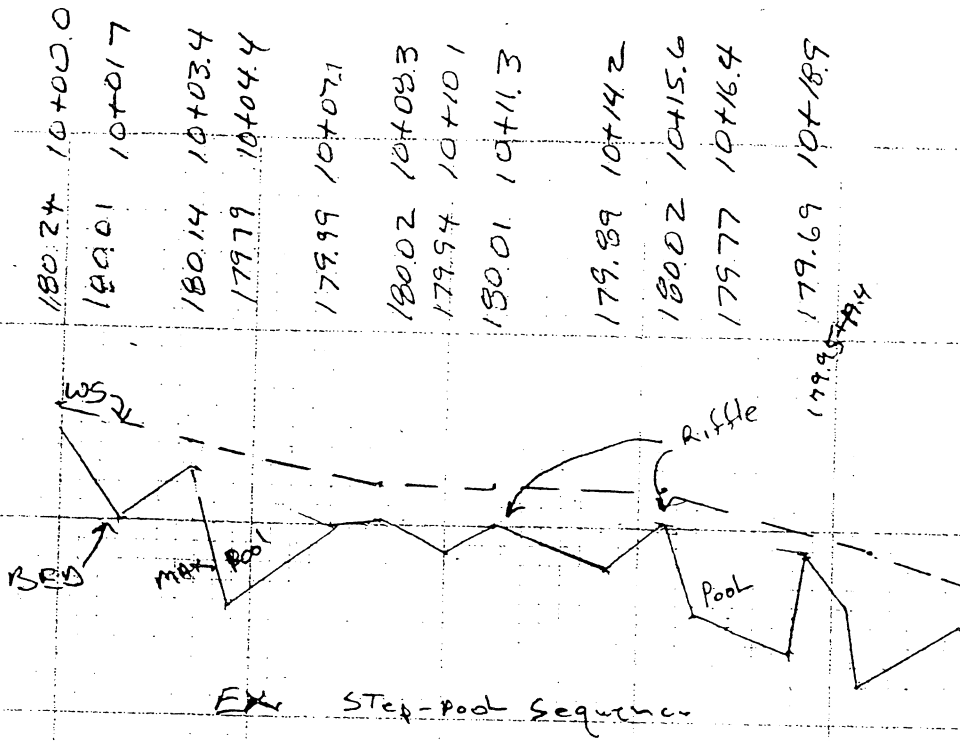

EXISTING THALweg PROFILE

10+00 +10 +20 +30

I 268+40 RT-L-

PEBBLE COUNT

Site: Trib. To Big Mountain Crk.+/-268+40-R2231 CB Date: 4-05-01

Party: WHW, FFF, RHK

Particle Counts

Inches	Particle	Millimeter		Riffles	Pools	Total No.	Item %	% Cumulative
	Silt/Clay	< 0.062	S/C	12	0	12	12%	12%
.04 - .08	Very Fine	.062 - .125	S	24	0	24	24%	36%
	Fine	.125 - .25	A	24	0	24	24%	60%
	Medium	.25 - .50	N	8	0	8	8%	68%
	Coarse	.50 - 1.0	D	4	0	4	4%	72%
	Very Coarse	1.0 - 2.0	S	0	0	0	0%	72%
.08 - .16	Very Fine	2.0 - 4.0		0	0	0	0%	72%
.16 - .22	Fine	4.0 - 5.7	G	0	0	0	0%	72%
.22 - .31	Fine	5.7 - 8.0	R	6	0	6	6%	78%
.31 - .44	Medium	8.0 - 11.3	A	10	0	10	10%	88%
.44 - .63	Medium	11.3 - 16.0	V	8	0	8	8%	96%
.63 - .89	Coarse	16.0 - 22.6	E	4	0	4	4%	100%
.89 - 1.26	Coarse	22.6 - 32.0	L	0	0	0	0%	100%
1.26 - 1.77	Very Coarse	32.0 - 45.0	S	0	0	0	0%	100%
1.77 - 2.5	Very Coarse	45.0 - 64.0		0	0	0	0%	100%
2.5 - 3.5	Small	64 - 90	C	0	0	0	0%	100%
3.5 - 5.0	Small	90 - 128	O	0	0	0	0%	100%
5.0 - 7.1	Large	128 - 180	B	0	0	0	0%	100%
7.1 - 10.1	Large	180 - 256	L	0	0	0	0%	100%
10.1 - 14.3	Small	256 - 362	B	0	0	0	0%	100%
14.3 - 20	Small	362 - 512	L	0	0	0	0%	100%
20 - 40	Medium	512 - 1024	D	0	0	0	0%	100%
40 - 80	Lrg- Very Lrg	1024 - 2048	R	0	0	0	0%	100%
	Bedrock		BDRK		0	0	0%	100%
Totals				100	0	100	100%	100%

Particle Size Distribution

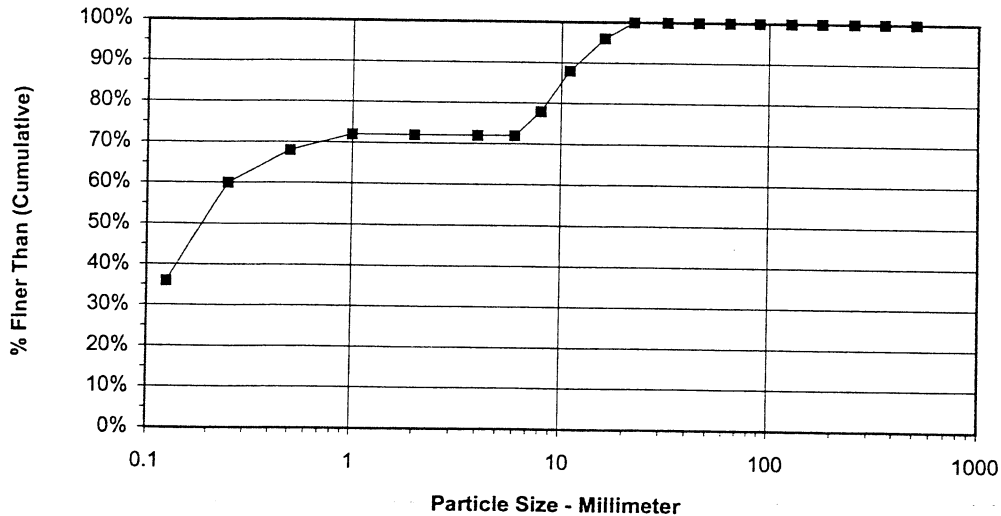

PLAN VIEW SITE 7

DENOTES FILL IN WETLANDS

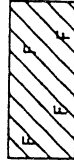

DENOTES FILL IN SURFACE WATERS

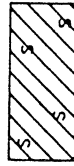

DENOTES MECHANIZED CLEARING



N. C. DEPT. OF TRANSPORTATION
DIVISION OF HIGHWAYS
MONTGOMERY COUNTY

PROJECT: 8.T550803 (R2231CB)

US 220 BYPASS

SHEET 33 OF 35 REV. 9/02

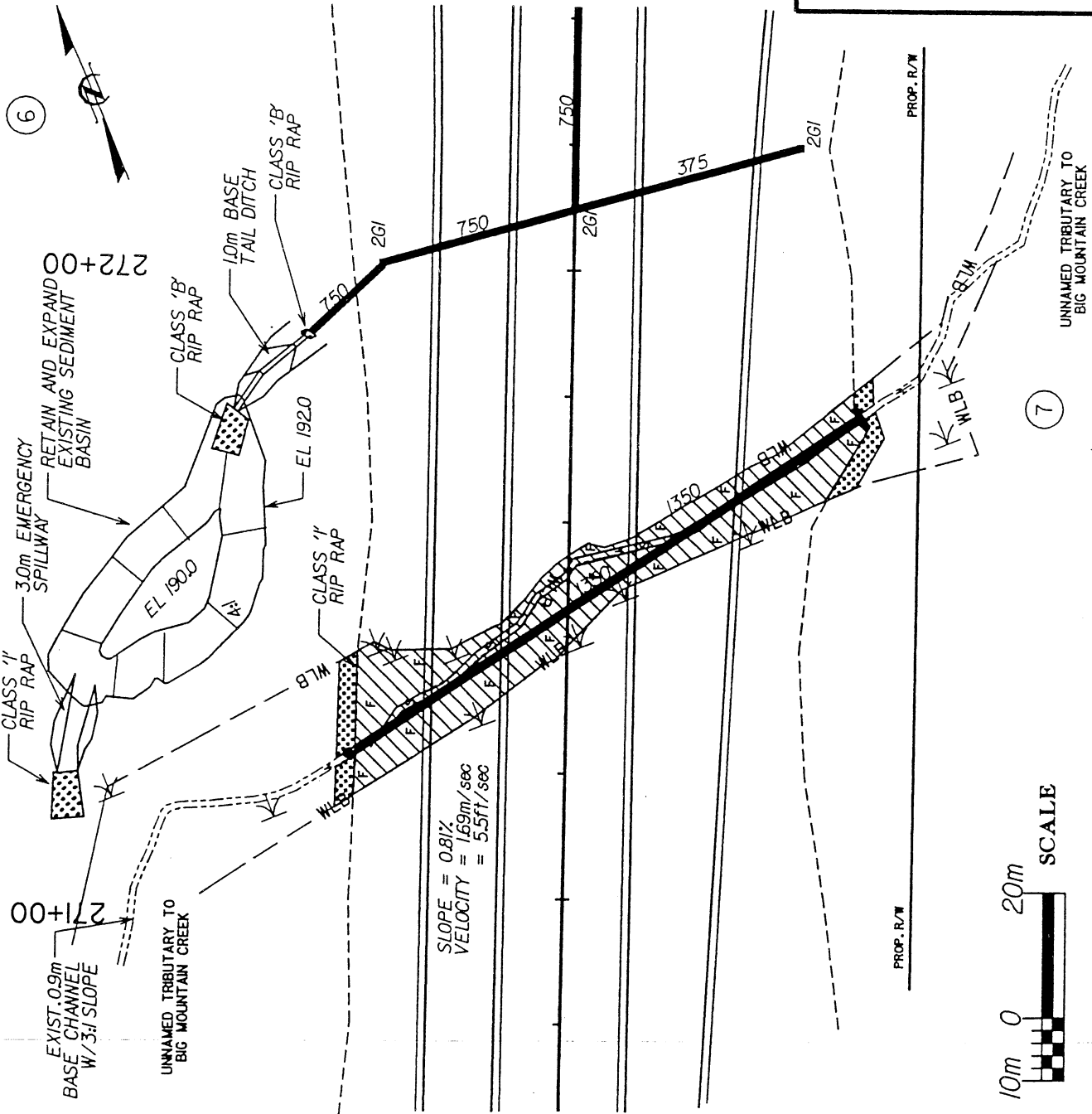

WETLAND PERMIT IMPACT SUMMARY

Site No.	Station (From/To)	Structure Size / Type	WETLAND IMPACTS				SURFACE WATER IMPACTS				Natural Stream Design (m)	
			Fill In Wetlands (ha)	Temp. Fill In Wetlands (ha)	Excavation In Wetlands (ha)	Mechanized Clearing (Method III) (ha)	Fill In SW (Natural) (ha)	Fill In SW (Pond) (ha)	Temp. Fill In SW (ha)	Existing Channel Impacted (m)		
1	242+80-L-	1050 rcp	0.205		0.0035	0.016	0.021				172	
2	249+60-249+80-L-	N/A	0.014			0.006						
3	253+00-255+60-L-	1 @ 2.1m X 1.5m RCBC	0.745		0.0165	0.101	0.027				230	129
4	258+40-259+10-L-	450 rcp	0.254			0.007						
5	260+20-261+60-L-	1500 rcp	0.523		0.0004	0.03	0.029				146	
6	267+80-268+80-L-	1500 rcp	0.361		0.0074	0.047	0.025				175	77
7	271+20-271+80-L-	1350 rcp	0.089			0.011	0.01				98	
TOTALS:			2.191	0	0.0278	0.218	0.112	0	0	0	821	206

DIVISION OF HIGHWAYS
PROJECT 8:1550803 (R-2231CB)

US 220 BYPASS

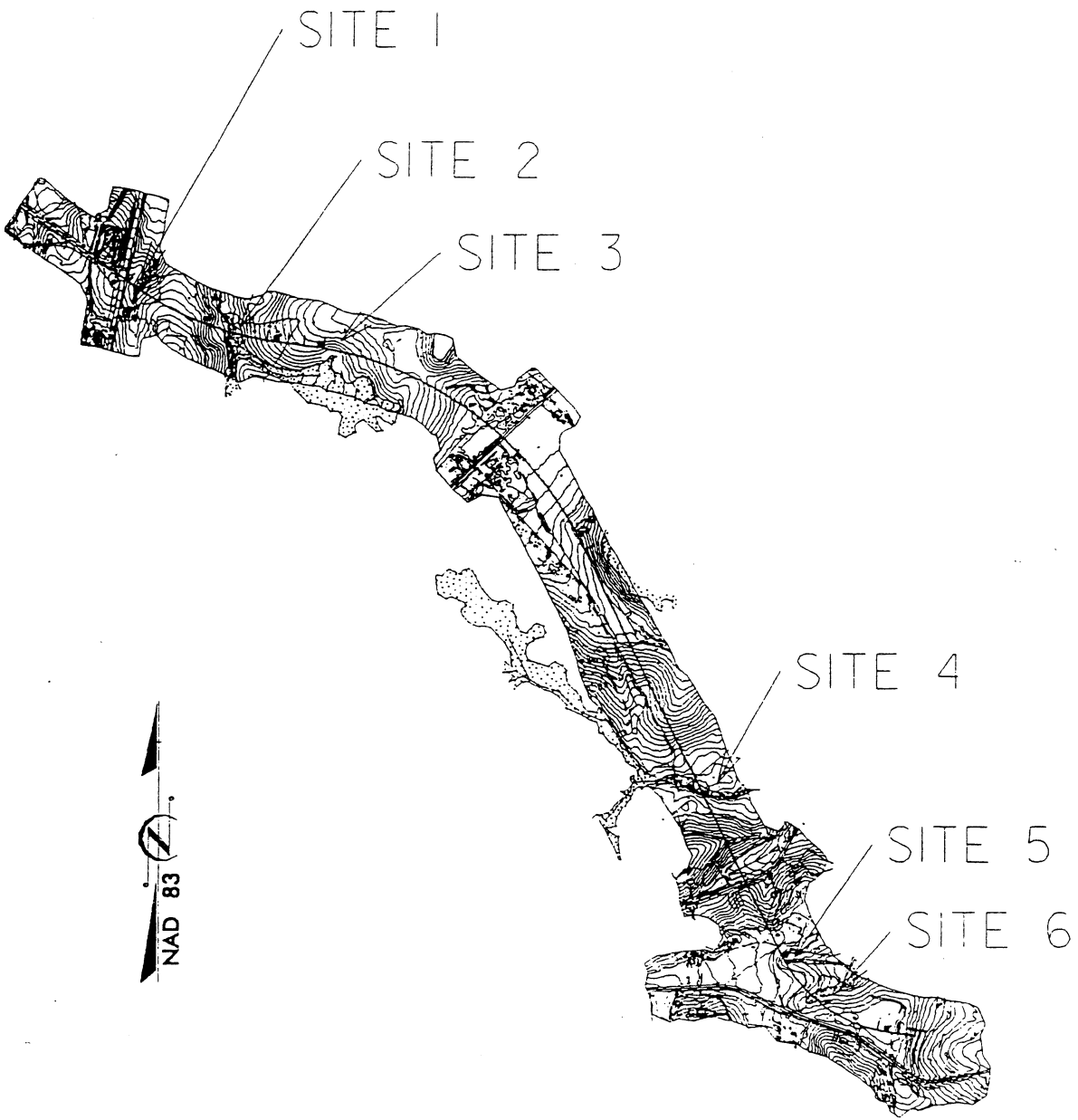

SITE MAP

NCDOT
DIVISION OF HIGHWAYS
RICHMOND COUNTY
PROJECT: 8.1581201 (R-5505)
NC 75 EXT FROM
EXISTING NC 75 / US 220
TO SR 1452
SHEET 2 OF 12 08/26/02

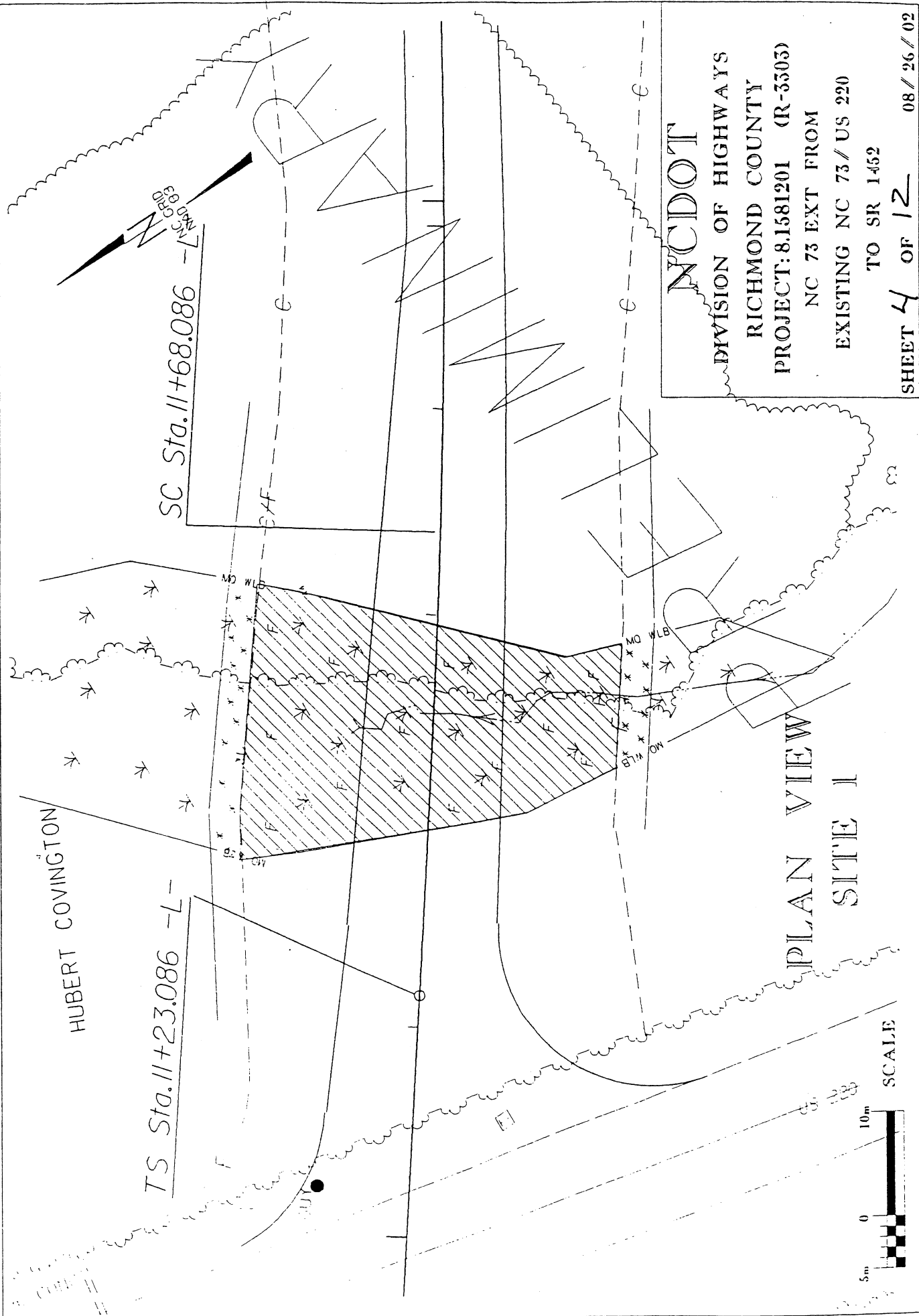









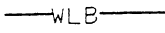

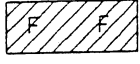
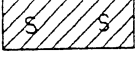
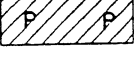

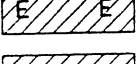
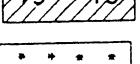
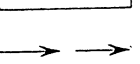
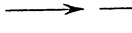
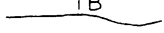
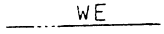
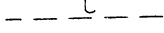
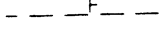

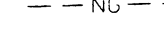

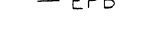
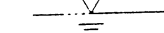
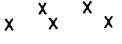

NC DOT
 DIVISION OF HIGHWAYS
 RICHMOND COUNTY
 PROJECT: 8.1581201 (R-3303)
 NC 73 EXT FROM
 EXISTING NC 73 / US 220
 TO SR 1452
 SHEET 4 OF 12 08 / 26 / 02

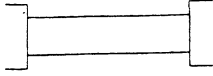
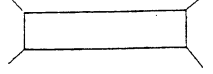
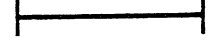
PLAN VIEW
 SITE 1

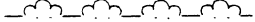
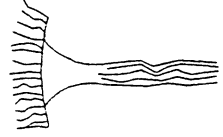
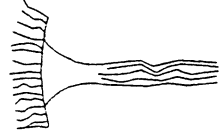

WETLAND LEGEND

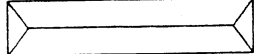
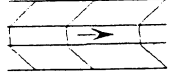
-  WETLAND BOUNDARY
-  WETLAND
-  DENOTES FILL IN WETLAND
-  DENOTES FILL IN SURFACE WATER
-  DENOTES FILL IN SURFACE WATER (POND)
-  DENOTES TEMPORARY FILL IN WETLAND
-  DENOTES EXCAVATION IN WETLAND
-  DENOTES TEMPORARY FILL IN SURFACE WATER
-  DENOTES MECHANIZED CLEARING
-  FLOW DIRECTION
-  TOP OF BANK
-  EDGE OF WATER
-  PROP. LIMIT OF CUT
-  PROP. LIMIT OF FILL
-  PROP. RIGHT OF WAY
-  NATURAL GROUND
-  PROPERTY LINE
-  TEMP. DRAINAGE EASEMENT
-  PERMANENT DRAINAGE EASEMENT
-  EXIST. ENDANGERED ANIMAL BOUNDARY
-  EXIST. ENDANGERED PLANT BOUNDARY
-  WATER SURFACE
-  LIVE STAKES
-  BOULDER
-  CORE FIBER ROLLS
-  PROPOSED BRIDGE
-  PROPOSED BOX CULVERT
-  PROPOSED PIPE CULVERT
12"-48" PIPES
54" PIPES & ABOVE
- (DASHED LINES DENOTE EXISTING STRUCTURES)
-  SINGLE TREE
-  WOODS LINE
-  DRAINAGE INLET
-  ROOTWAD
-  RIP RAP
-  ADJACENT PROPERTY OWNER OR PARCEL NUMBER IF AVAILABLE
-  PREFORMED SCOUR HOLE
-  LEVEL SPREADER (LS)
-  DITCH / GRASS SWALE

NCDOT
 DIVISION OF HIGHWAYS
 RICHMOND COUNTY
 PROJECT: 8.1581201 (R-5505)
 NC 75 EXT FROM
 EXISTING NC 75/ US 220
 TO SR 1452
 SHEET **3** OF **12** 08/26/02

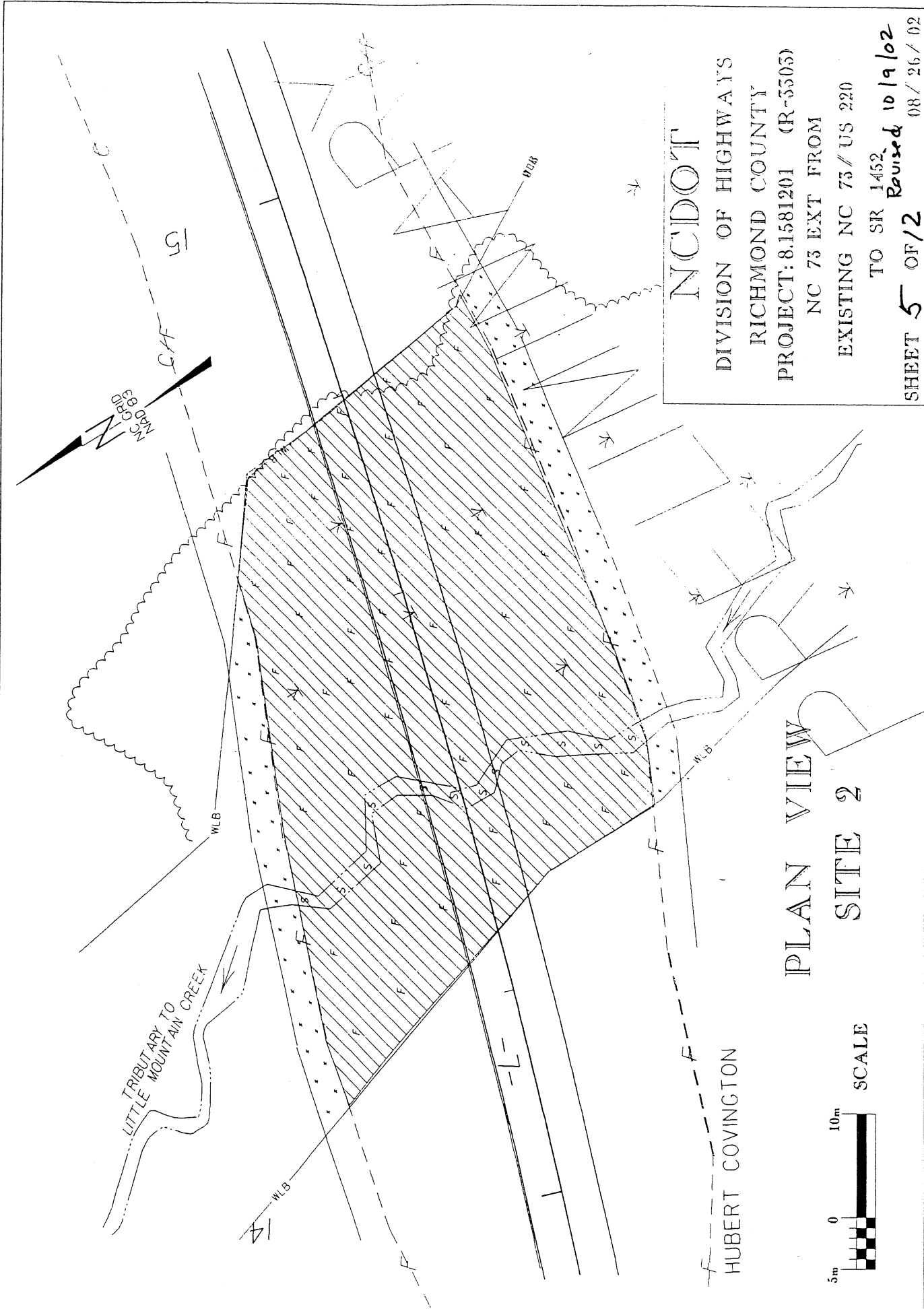

NCDOT

DIVISION OF HIGHWAYS
 RICHMOND COUNTY
 PROJECT: 8.1581201 (R-5505)
 NC 73 EXT FROM
 EXISTING NC 73 / US 220

TO SR 1452
 Revised 10/19/02
 SHEET 5 OF 2 08 / 26 / 02

PLAN VIEW
 SITE 2

HUBERT COVINGTON

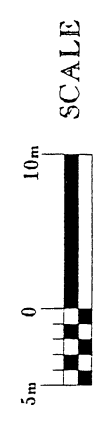

81

EDWARD & DELORIS MYRICK

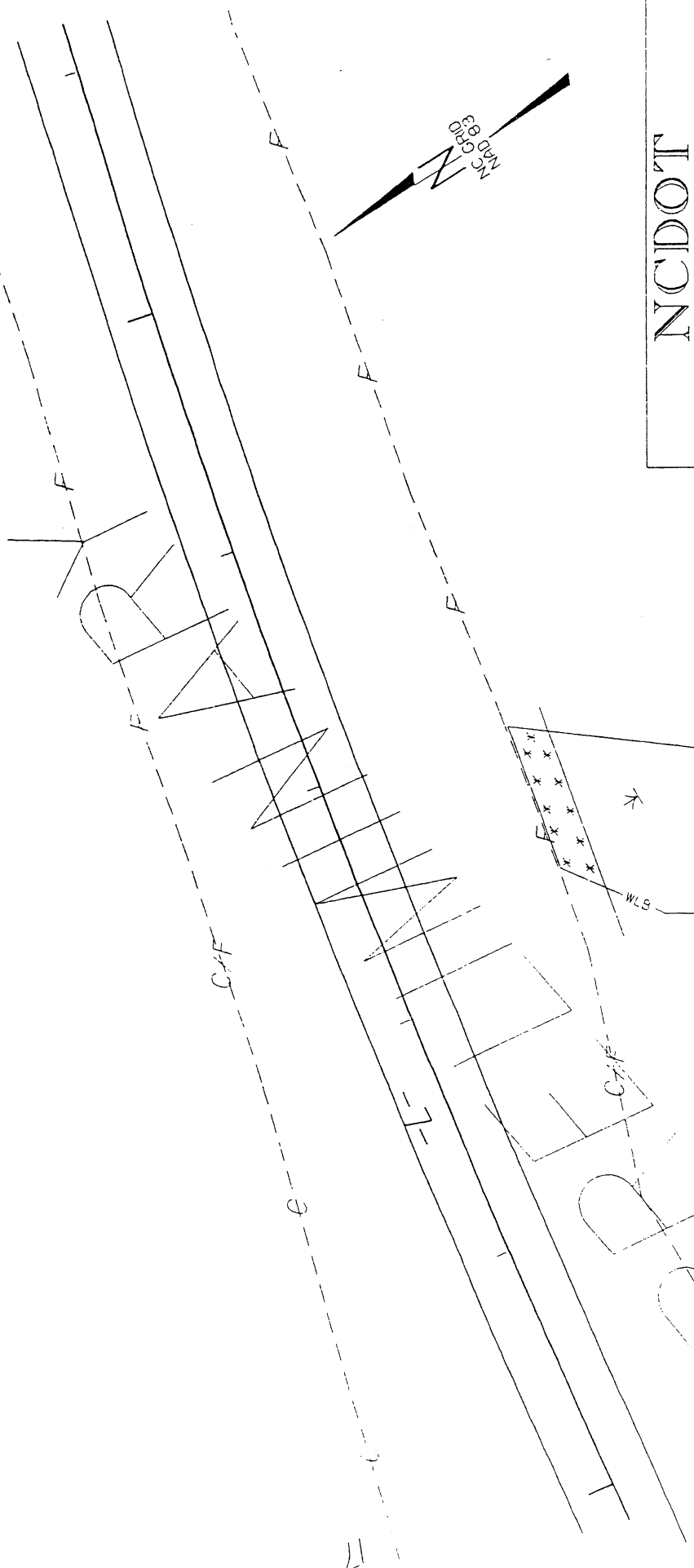

PLAN VIEW
SITE 3

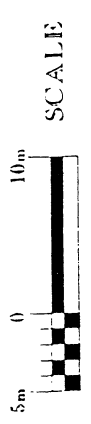

SCALE

NCDOT
 DIVISION OF HIGHWAYS
 RICHMOND COUNTY
 PROJECT: 8.1581201 (R-3303)
 NC 73 EXT FROM
 EXISTING NC 73/ US 220
 TO SR 1452

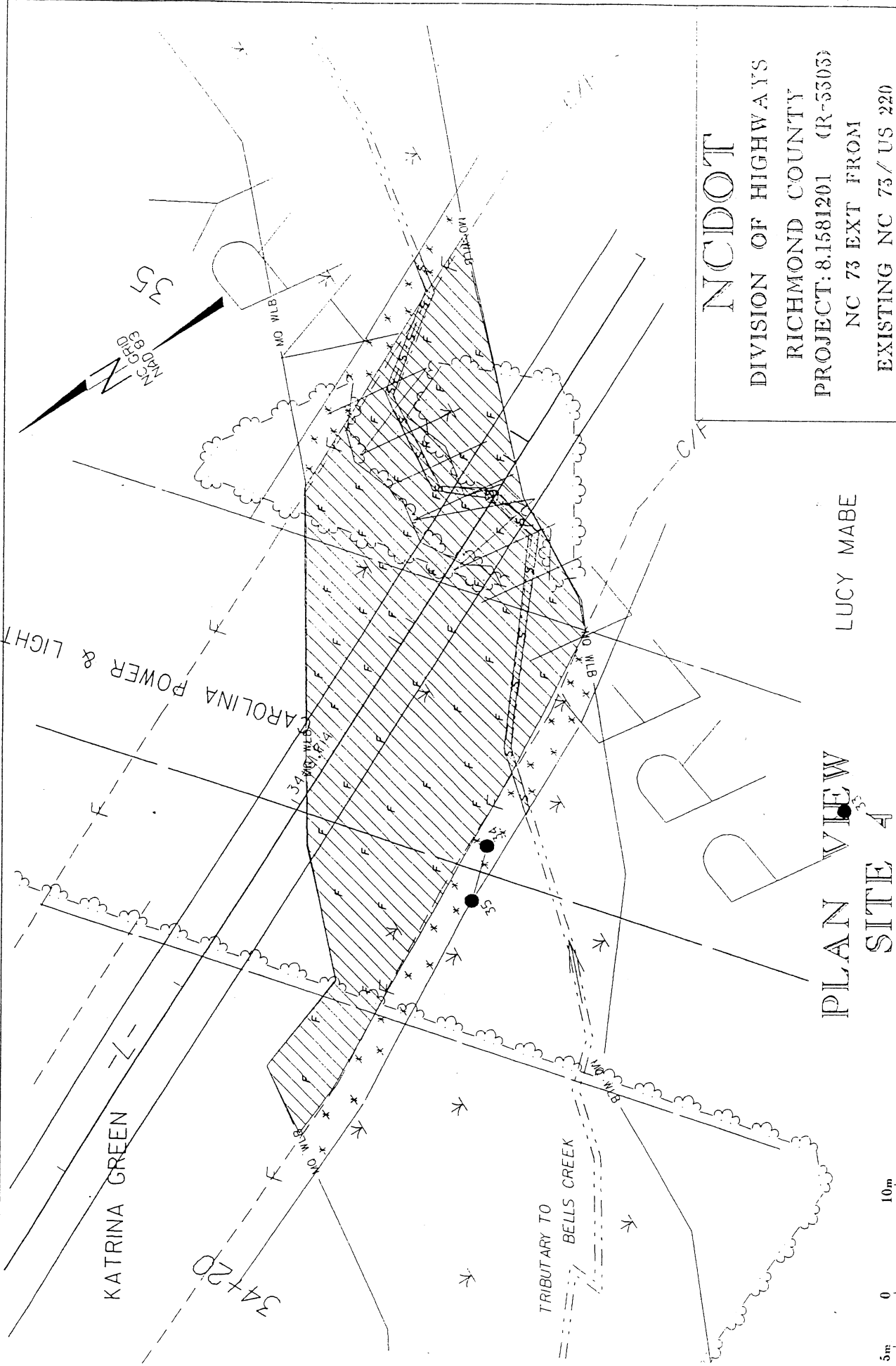

PLAN VIEW
SITE 4

LUCY MABE

NCDOT
 DIVISION OF HIGHWAYS
 RICHMOND COUNTY
 PROJECT: 8.1581201 (R-5303)
 NC 73 EXT FROM
 EXISTING NC 73 / US 220
 TO SR 1452 Revised 10/9/02
 SHEET 7 OF 12 08 / 26 / 02

PROPERTY OWNERS

NAMES AND ADDRESSES

NAMES	ADDRESSES
HUBERT COVINGTON	2260 NORTH US 220 ELLERBE, NC 28538
EDWARD & DELORIS MYRICK	4450 NE 31 AVE POMPANO BEACH, FL 33064
KATRINA GREEN	2370 SPRINGS RUN WAY DECATUR, GA 30032
LUCY MABE	249 FIRETOWER RD ELLERBE, NC 28538
ROGER ALLRED, SR, ET AL	6726 LANCER DR CHARLOTTE, NC 28226
RICHARD & RUBY HENDERSON	P.O. BOX 465 ELLERBE, NC 28538

NCDOT
DIVISION OF HIGHWAYS
RICHMOND COUNTY
PROJECT: 8.1581201 (R-5505)
NC 75 EXT FROM
EXISTING NC 75/ US 220
TO SR 1452
SHEET 10 OF 12 08/26/02

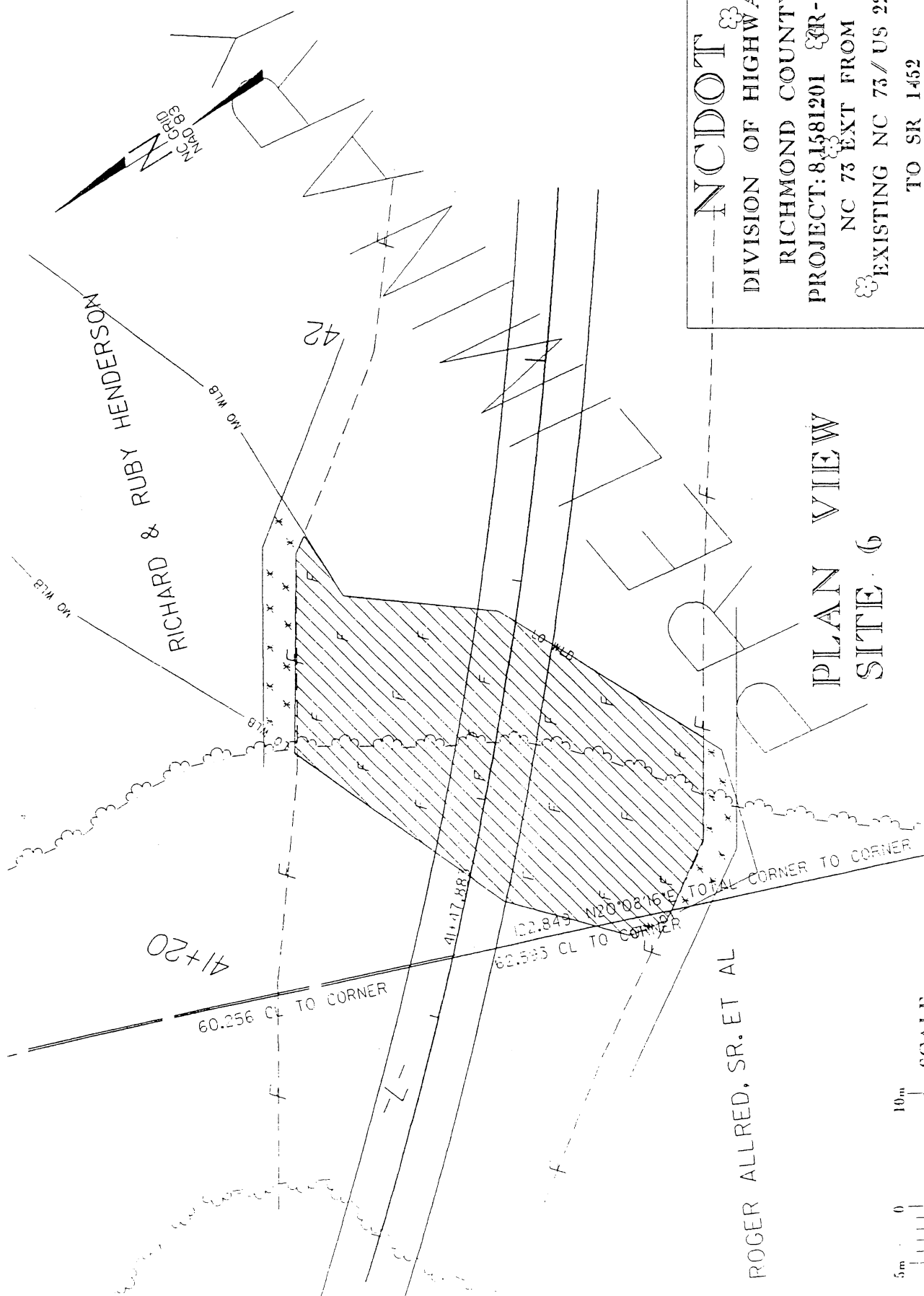

NCDOT
 DIVISION OF HIGHWAYS
 RICHMOND COUNTY
 PROJECT: 81581201 (R-3305)
 NC 73 EXT FROM
 EXISTING NC 73/US 220

TO SR 1452

SHEET 9 OF 12

08/26/02

PLAN VIEW
 SITE 6

ROGER ALLRED, SR. ET AL

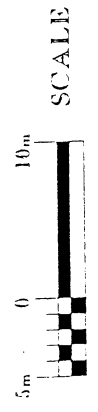

SCALE

WETLAND PERMIT IMPACT SUMMARY

Site No.	Station (From/To)	Structure Size / Type	WETLAND IMPACTS						SURFACE WATER IMPACTS							
			Fill In Wetlands (ha)	Temp. Fill In Wetlands (ha)	Excavation In Wetlands (ha)	Mechanized Clearing (Method III) (ha)	Fill In SW (Natural) (ha)	Fill In SW (Pond) (ha)	Temp. Fill In SW (ha)	Existing Channel Impacted (m)	Natural Stream Design (m)					
1	11+50 -L-		0.071			0.011										
2	14+30 to 14+80-L-		0.182			0.030		0.007					50			
3	17+50 -L-					0.004										
4	34+40 to 35+00 -L-		0.117			0.024		0.004								
5	40+35 -L-		0.006			0.002										
6	41+40 to 41075 -L-		0.086													
TOTALS:			0.462	0	0	0.071	0.011	0	0	0	0	0	112			0

NC DEPARTMENT OF TRANSPORTATION
 DIVISION OF HIGHWAYS
 RICHMOND COUNTY
 PROJECT: 8.1581201 (R-3303)
 NC73 EXT FROM NC73/US220 TO SR1452
 SHEET 11 OF 12 Revised 10/19/02
8/26/02

WETLAND PERMIT IMPACT SUMMARY

Site No.	Station (From/To)	Structure Size / Type	WETLAND IMPACTS						SURFACE WATER IMPACTS					
			Fill In Wetlands (ac)	Temp. Fill In Wetlands (ac)	Excavation In Wetlands (ac)	Mechanized Clearing (Method III) (ac)	Fill In SW (Natural) (ac)	Fill In SW (Pond) (ac)	Temp. Fill In SW (ac)	Existing Channel Impacted (ft)	Natural Stream Design (ft)			
1	11+50 -L-		0.18			0.03								
2	14+30 to 14+80-L-		0.45			0.07		0.02					164.00	
3	17+50 -L-					0.01								
4	34+40 to 35+00 -L-		0.29			0.06		0.01					203.36	
5	40+35 -L-		0.01			0.00								
6	41+40 to 41075 -L-		0.21											
TOTALS:			1.14	0.00	0.00	0.18	0.03	0.00	0.00	0.00	0.00	0.00	367.36	0.00

NC DEPARTMENT OF TRANSPORTATION
 DIVISION OF HIGHWAYS
 RICHMOND COUNTY
 PROJECT: 8.1581201 (R-3303)
 NC73 EXT FROM NC73/JUS220 TO SR1452
 SHEET **12 of 12** Revised 10/19/02
 8/26