

Michael F. Easley, Governor  
William G. Ross Jr., Secretary  
North Carolina Department of Environment and Natural Resources

Alan W. Klimek, P.E. Director  
Division of Water Quality  
Coleen H. Sullins, Deputy Director  
Division of Water Quality

August 18, 2003  
DWQ No. 030745  
Wake County

Dr. Gregory J. Thorpe, PhD., Manager  
Planning and Environmental Branch  
North Carolina Department of Transportation  
1548 Mail Service Center  
Raleigh, North Carolina, 27699-1548

Re: Wake County, Construction of a New Pedestrian and Bike Path from the Corner of Faircloth Street and Hillsborough Street to the North Carolina Art Museum in Raleigh in Wake County.  
State Project No. 8.1999903; TIP E-3806AA.  
House Creek [27-33-13; C NSW]

**APPROVAL of NEUSE RIVER BUFFER RULES AUTHORIZATION CERTIFICATE with ADDITIONAL CONDITIONS**

Dear Dr. Thorpe,

You have our approval, in accordance with the attached conditions, to impact 7,707 square feet (3,823 in Zone 1 and 3,884 square feet in Zone 2) of protected riparian buffers for the purpose of constructing a new pedestrian and bike path from the corner of Faircloth Street and Hillsborough Street to the North Carolina Art Museum in Raleigh in Wake County. The project shall be constructed according to your application dated June 13, 2993 and the addendum dated August 14, 2003 and any conditions listed below. The project construction shall adhere strictly to the design presented in the August 14, 2003 addendum (received in DWQ office August 15, 2003). This approval shall act as your Authorization Certificate as required within the Neuse River Area Protection Rules (15A NCAC 2B .0233). In addition, you should get any other required federal, state or local permits before you go ahead with your project including (but not limited to) Sediment and Erosion Control.

This approval is only valid for the purpose and design that you described in your application dated August 14, 2003. If you change your project, you must notify us and you may be required to send us a new application. If the property is sold, the new owner must be given a copy of this authorization and approval letter and is thereby responsible for complying with all conditions. For this approval to be valid, you must follow the conditions listed below.

- "Grassed swales" with minimum slopes of 3:1 and constructed in accordance with the "NC DENR Stormwater Best Management Practices" as described within your application from Station Number 91+11 to Station Number 93+50.
- All pre-formed scour holes and other flow spreader devices installed as part of the project shall provide discharge as diffuse flow at non-erosive velocities.

If you do not accept any of the conditions of this authorization, you may ask for an adjudicatory hearing. You must act within 60 days of the date that you receive this letter. To ask for a hearing, send a written petition, which conforms to Chapter 150B of the North Carolina General Statutes to the Office of Administrative Hearings, P.O. Box 27447, Raleigh, N.C. 27611-7447. This authorization and its conditions are final and binding unless you ask for a hearing.

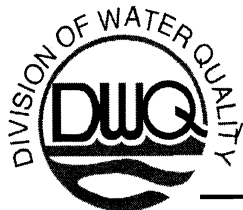

Michael F. Easley, Governor  
William G. Ross Jr., Secretary  
North Carolina Department of Environment and Natural Resources  
Alan W. Klimek, P.E. Director

This letter completes the review of the Division of Water Quality under the "No Practical Alternatives" determination required in 15A NCAC 2B .0233(8). If you have any questions, please contact John Hennessy at 919-733-5694.

Sincerely,

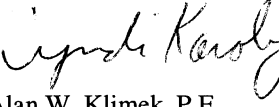
  
for Alan W. Klimek, P.E.  
Director

cc: US Army Corps of Engineers Raleigh Field Office  
DWQ Raleigh Regional Office  
File Copy  
Central Files

C:\ncdot\TIP E-3806\wqc\030745 buffer authorization.doc

**Bike Path**  
**from the corner of Faircloth Street and Hillsborough Street**  
**to the North Carolina Art Museum in**  
**Raleigh, Wake County.**  
**State Project No. 8.1999903**  
**E-3806AA**

The following special commitments have been agreed to by NCDOT:

Commitments Developed Through Project Design

Bicycle and Pedestrian Division, Division 5 Construction

The alignment will not require the removal of any large trees.

Commitments Developed Through Permitting

Bicycle and Pedestrian Division, Division 5 Construction

Grassed swales with minimum slopes of 3:1 shall be constructed in accordance with the NC DENR Stormwater Best Management Practices from Station 91+11 to Station 93+50.

All pre-formed scour holes and other flow spreader devices which are installed as part of the project shall provide discharge as diffuse flow at non-erosive velocities.

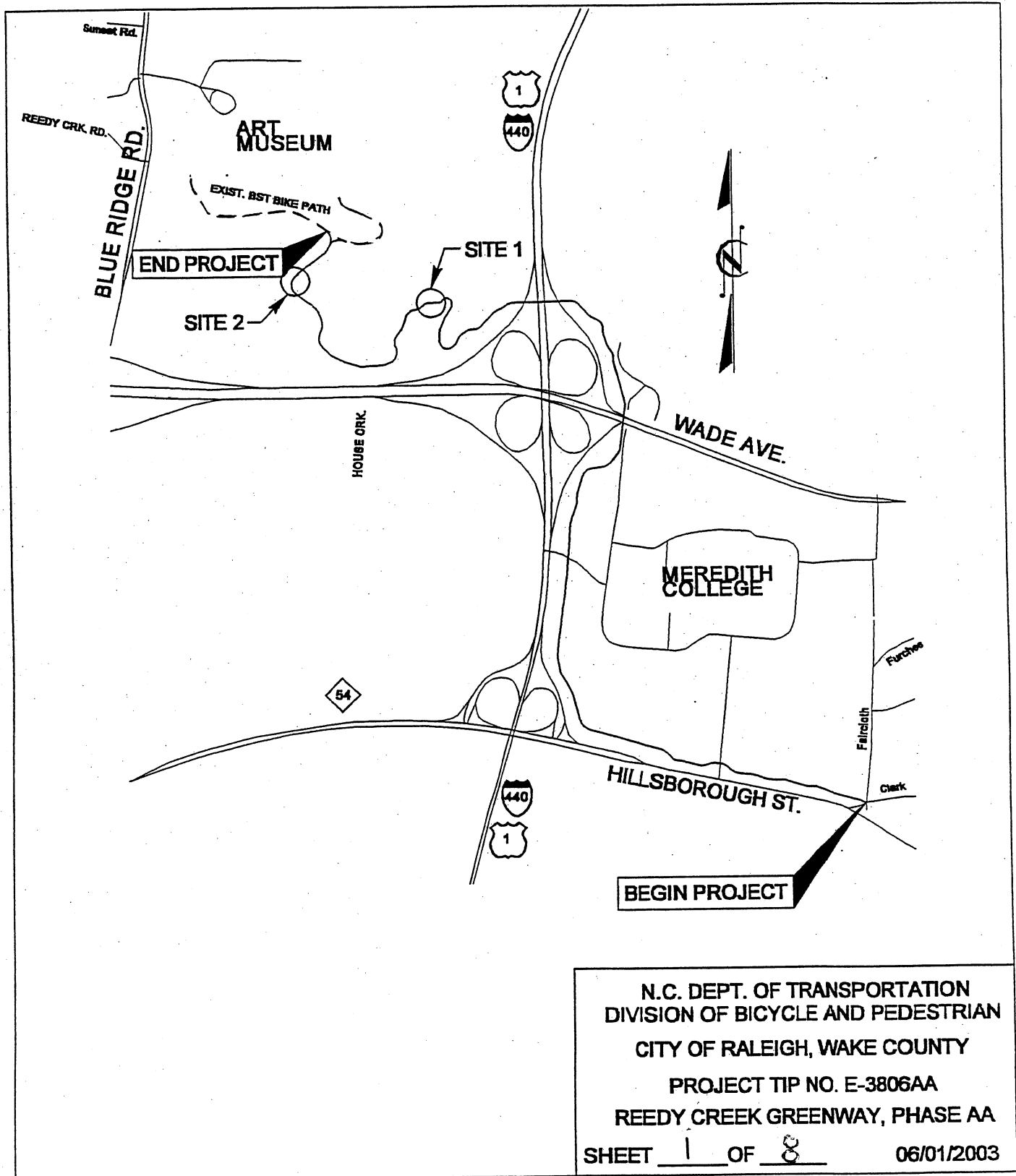

N.C. DEPT. OF TRANSPORTATION  
 DIVISION OF BICYCLE AND PEDESTRIAN  
 CITY OF RALEIGH, WAKE COUNTY  
 PROJECT TIP NO. E-3806AA  
 REEDY CREEK GREENWAY, PHASE AA  
 SHEET 1 OF 8 06/01/2003

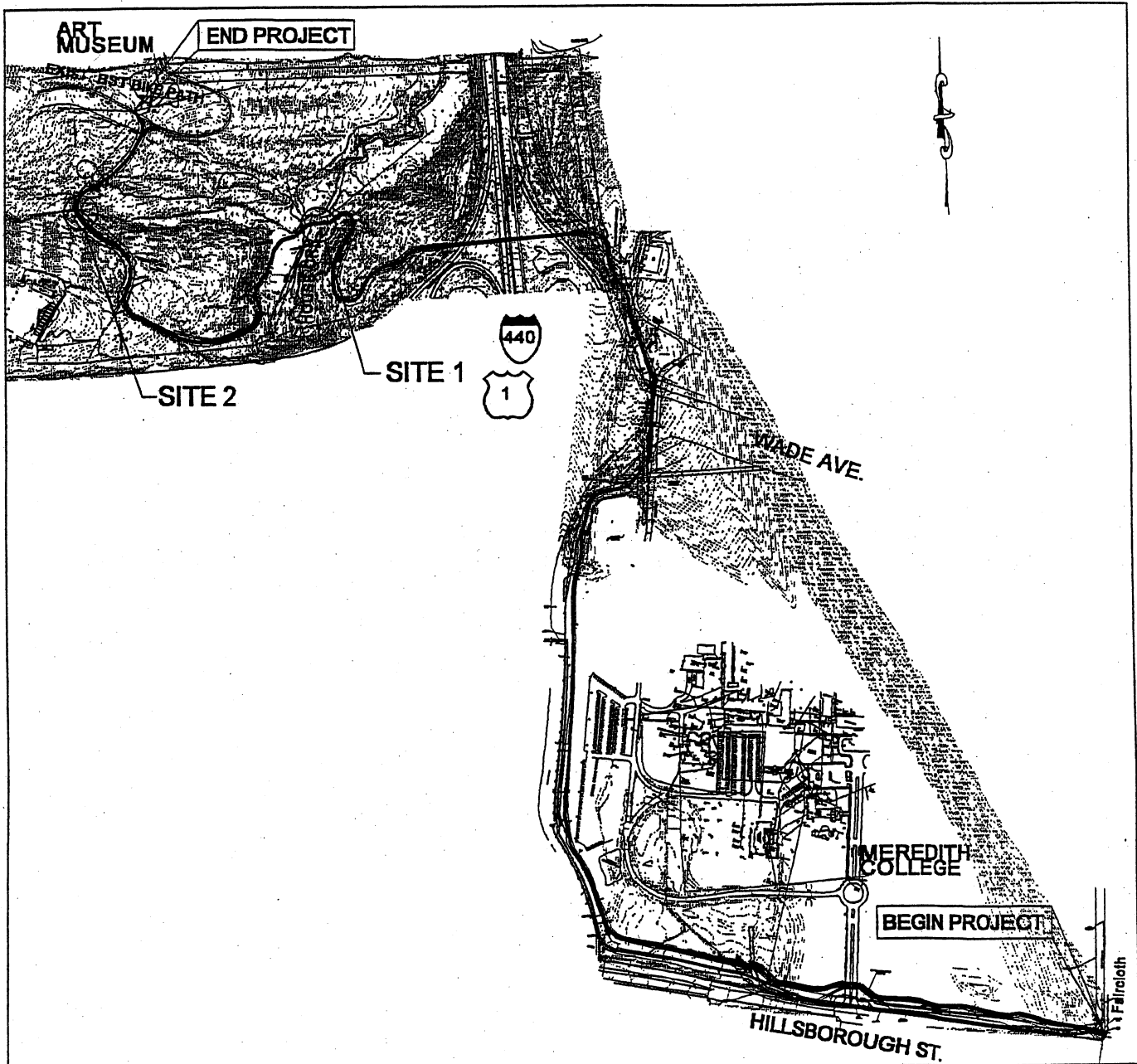

N.C. DEPT. OF TRANSPORTATION  
 DIVISION OF BICYCLE AND PEDESTRIAN  
 CITY OF RALEIGH, WAKE COUNTY  
 PROJECT TIP NO. E-3806AA  
 REEDY CREEK GREENWAY, PHASE AA  
 SHEET 2 OF 8 06/01/2003

# BUFFER LEGEND

— WLB — WETLAND BOUNDARY

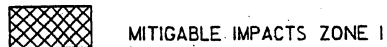
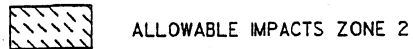
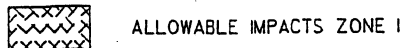
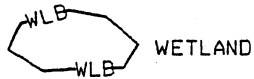

— BZ — RIPARIAN BUFFER ZONE

— BZ1 — RIPARIAN BUFFER ZONE 1  
30 ft (9.2m)

— BZ2 — RIPARIAN BUFFER ZONE 2  
20 ft (6.1m)

→ → → FLOW DIRECTION

— TB — TOP OF BANK

— WE — EDGE OF WATER

— C — PROP. LIMIT OF CUT

— E — PROP. LIMIT OF FILL

— Δ — PROP. RIGHT OF WAY

— NG — NATURAL GROUND

— PL — PROPERTY LINE

— TDE — TEMP. DRAINAGE EASEMENT

— PDE — PERMANENT DRAINAGE EASEMENT

— EAB — EXIST. ENDANGERED ANIMAL BOUNDARY

— EPB — EXIST. ENDANGERED PLANT BOUNDARY

— ∇ — WATER SURFACE

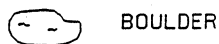
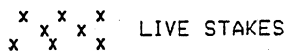

— — — CORE FIBER ROLLS

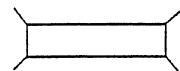
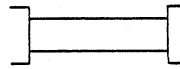

(DASHED LINES DENOTE EXISTING STRUCTURES)

12'-48"  
PIPES  
54" PIPES  
& ABOVE

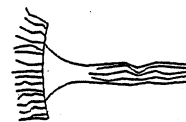

ADJACENT PROPERTY OWNER OR PARCEL NUMBER IF AVAILABLE

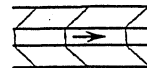
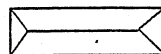

N. C. DEPT. OF TRANSPORTATION  
DIVISION BICYCLE AND PEDESTRIAN  
CITY OF RALEIGH, WAKE COUNTY  
PROJECT TIP NO: E-3806AA  
REEDY CREEK GREENWAY, PHASE AA

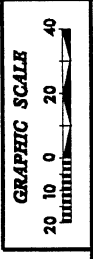
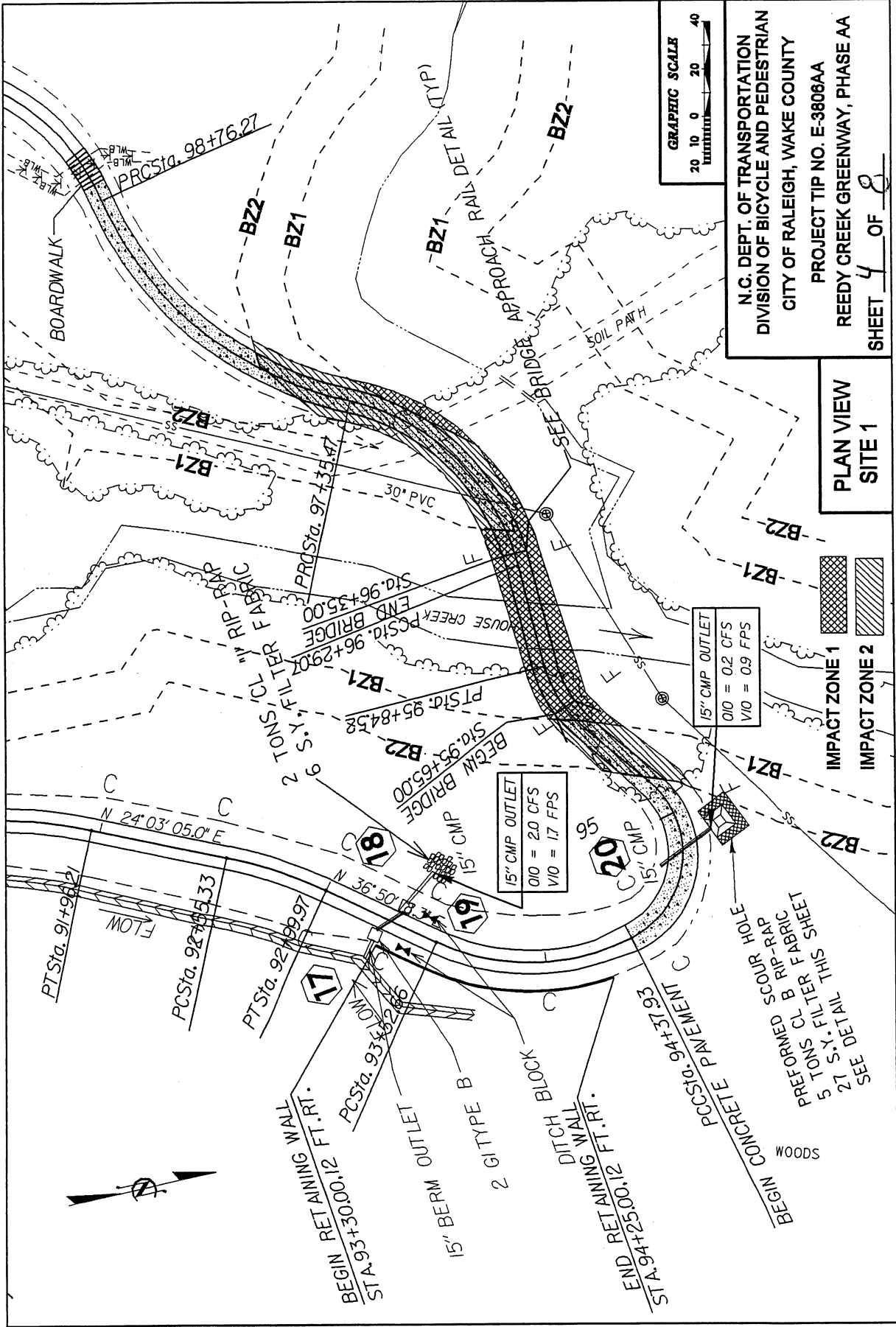

N.C. DEPT. OF TRANSPORTATION  
 DIVISION OF BICYCLE AND PEDESTRIAN  
 CITY OF RALEIGH, WAKE COUNTY  
 PROJECT TIP NO. E-3806AA  
 REEDY CREEK GREENWAY, PHASE AA  
 SHEET 4 OF 8

PLAN VIEW  
 SITE 1

IMPACT ZONE 1  
 IMPACT ZONE 2

Revised 8-15-03



PTSta. 91+98.21  
 PCSta. 92+55.33  
 PTSta. 92+89.97  
 PCSta. 93+02.66  
 PTSta. 94+37.92

FLOW

BEGIN RETAINING WALL  
 STA. 93+30.00, 12 FT. RT.  
 STA. 94+25.00, 12 FT. RT.

15" BERM OUTLET  
 2 GITYPE B  
 DITCH BLOCK  
 BEGIN CONCRETE PAVEMENT

15" CMP OUTLET  
 O/D = 20 CFS  
 V/O = 17 FPS

15" CMP OUTLET  
 O/D = 0.2 CFS  
 V/O = 0.9 FPS

SEE DETAIL THIS SHEET  
 5 TONS CL B RIP-RAP  
 5 TONS CL B RIP-RAP  
 REFORMED SCOUR HOLE

WOODS

IMPACT ZONE 1  
 IMPACT ZONE 2

PLAN VIEW  
 SITE 1

N.C. DEPT. OF TRANSPORTATION  
 DIVISION OF BICYCLE AND PEDESTRIAN  
 CITY OF RALEIGH, WAKE COUNTY  
 PROJECT TIP NO. E-3806AA  
 REEDY CREEK GREENWAY, PHASE AA  
 SHEET 4 OF 8

Revised 8-15-03





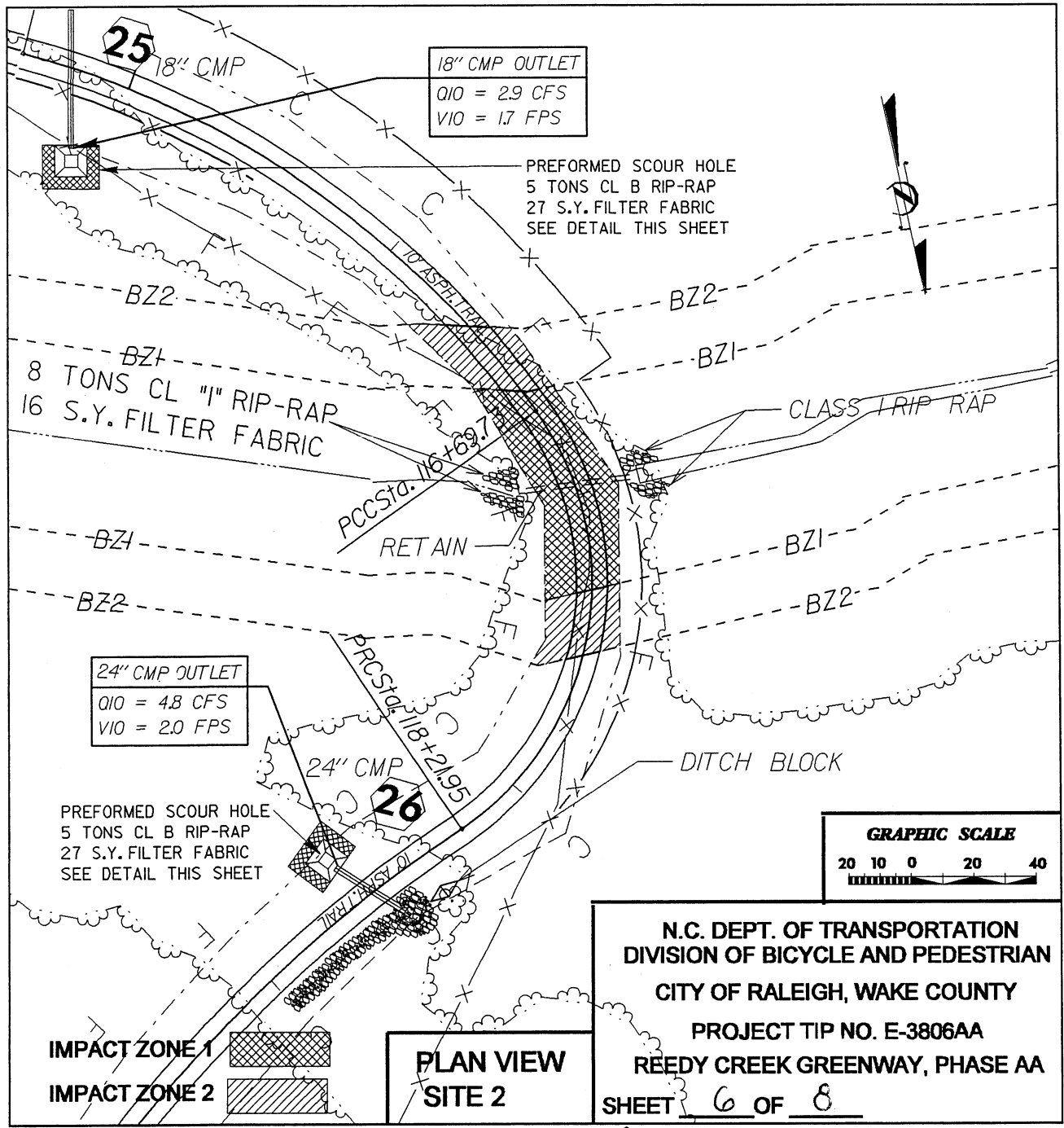

Revised 8-15-03

# PROPERTY OWNERS

## NAMES AND ADDRESSES

NO.	NAMES	ADDRESSES
1	N.C.MUSEUM OF ART	4630 MAIL SERVICE CENTER RALEIGH, NC 27699-4630
2	N.C.MUSEUM OF ART	4630 MAIL SERVICE CENTER RALEIGH, NC 27699-4630

N. C. DEPT. OF TRANSPORTATION  
DIVISION OF BICYCLE AND PEDESTRIAN  
WAKE COUNTY  
PROJECT: E-3806AA  
REEDY CREEK GREENWAY, PHASE AA



STATE OF NORTH CAROLINA  
 DIVISION OF BICYCLE AND  
 PEDESTRIAN TRANSPORTATION

STATE	STATE PROJECT REFERENCE NO.	SHEET NO.	TOTAL SHEETS
N.C.	E-3806AA	1	
STATE PROJ. NO.	F.A. PROJ. NO.	DESCRIPTION	

# WAKE COUNTY

**LOCATION: FROM INTERSECTION OF HILLSBOROUGH ST.  
 AND FAIRCLOTH ST. TO N.C. MUSEUM OF ART**

**TYPE OF WORK: GRADING, PAVING, DRAINAGE, STRUCTURES, SIGNING  
 TRAFFIC CONTROL AND PAVEMENT MARKING**

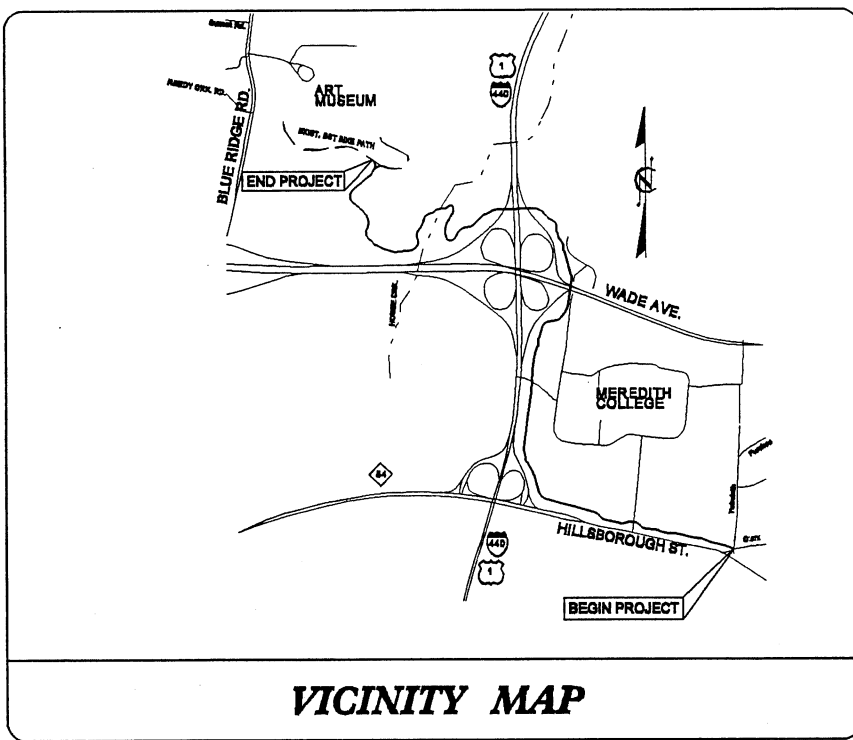

VICINITY MAP

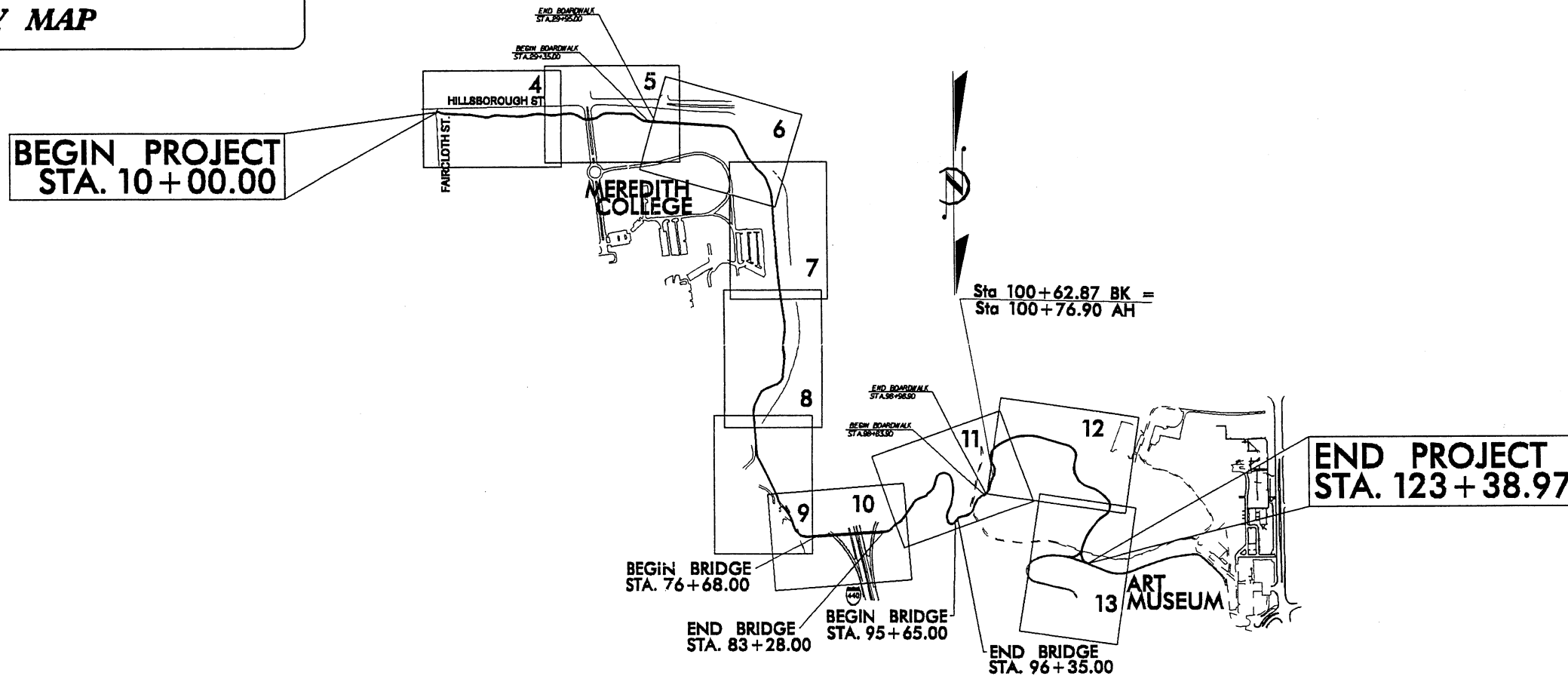

**PROJECT: E-3806AA**

I:\WIN-2003\_14124 R:\E-3806AA\_Mer-1d-Ar-W\Plan\3806aa.tsh ka-trivedi

INDEX OF SHEETS		
SHEET 1	TITLE SHEET	SHEETS 4 THRU 13
SHEET 1-A	SYMBOL SHEET	SHEETS PF-1 THRU PF-5
SHEET 2	PAVEMENT SCHEDULE	SHEETS TCP-1 THRU TCP-14
	TYPICAL SECTION	SHEETS E-1 THRU E-
SHEET 2-A	BOLLARD DETAILS	SHEETS SIGN-1 THRU SIGN-4
	TRAIL CONNECTION DETAIL	SHEETS U-1 THRU U-
	SIGN PLACEMENT DETAIL	SHEETS EC-1 THRU EC-22
SHEET 2-B	PIER PROTECTION DETAIL	SHEETS X-1 THRU X-52
SHEET 3	PIPE SUMMARY	SHEETS S-1 THRU S-
	EARTHWORK SUMMARY	
	GENERAL NOTES	
	LIST OF STANDARDS	

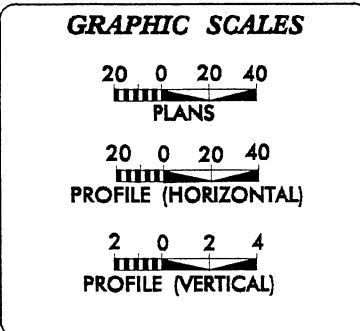

**HYDRAULICS ENGINEER**

SIGNATURE: \_\_\_\_\_ P.E.

**BICYCLE FACILITY DESIGN ENGINEER**

SIGNATURE: \_\_\_\_\_ P.E.

**DIVISION OF BICYCLE AND PEDESTRIAN TRANSPORTATION**

**PROJECT LENGTH**  
 TRAIL: 10,520 FEET / 1.99 MILES  
 BRIDGE STRUCT.: 730 FEET / 0.14 MILES  
 BOARDWALK: 75 FEET / 0.01 MILES  
 TOTAL: 11,325 FEET / 2.14 MILES

**DESIGN DATA**  
 V = 20 MPH  
 2002 SPECIFICATIONS

THOMAS P. NORMAN  
 DIRECTOR

**USE TYPICAL SECTION NO. 1  
AT FOLLOWING LOCATIONS**

- L- STA. 10+13.86 TO STA. 23+17.02
- L- STA. 23+94.41 TO STA. 29+35.00 (BEG. BOARDWALK)
- L- STA. 29+95 (END BOARDWALK) TO STA. 76+43 (BEG. APP. SLAB)
- L- STA. 83+53 (END APP. SLAB) TO STA. 94+37.93
- L- STA. 98+98.90 (END BOARDWALK) TO STA. 100+62.87 BK
- L- STA. 100+76.90 AH TO STA. 123+38.97
- L- SPR- STA. 10+00.00 TO STA. 11+45.17

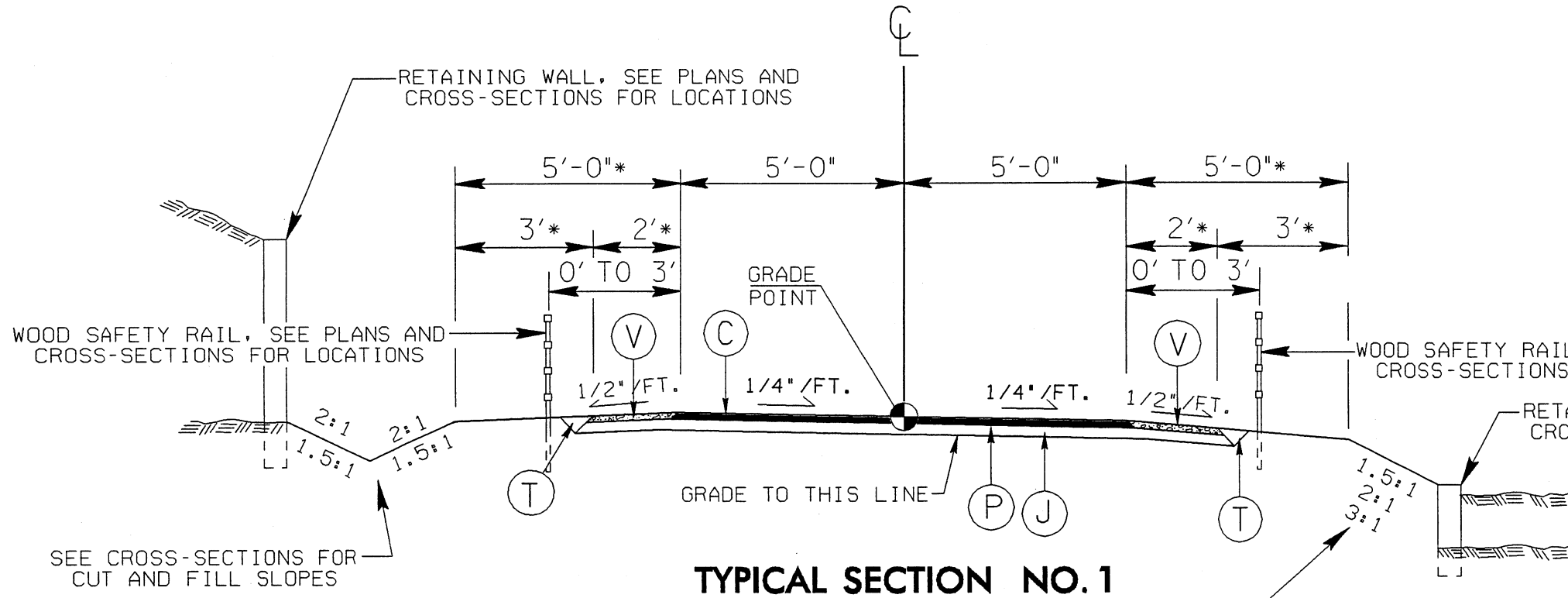

**TYPICAL SECTION NO. 1**

- \* VARIABLE SHOULDER WIDTH  
SEE X-SECTIONS AT FOLLOWING LOCATIONS**
- L- STA. 19+50 TO STA. 21+00
  - L- STA. 28+50 TO STA. 33+50
  - L- STA. 56+00 TO STA. 64+50
  - L- STA. 91+00 TO STA. 94+37.93
  - L- STA. 99+21.52 TO STA. 111+00

**PAVEMENT SCHEDULE**

C	PROP. APPROX. 2" BIT. CONC. SURFACE COURSE. TYPE SF 9.5 A. AT AN AVERAGE RATE OF 110 LBS. PER SQ. YD. IN EACH OF TWO LAYERS.
J	PROP. 6" AGGREGATE BASE COURSE.
P	PRIME COAT AT THE RATE OF 0.35 GAL. PER SQ. YD.
S	6" CONCRETE.
T	EARTH MATERIAL.
V	PROPOSED APPROXIMATE 2" OF SELECT GRANULAR MATERIAL.

NOTE: ALL PAVEMENT EDGE SLOPES ARE 1:1.

**USE TYPICAL SECTION NO. 2  
AT FOLLOWING LOCATIONS**

- L- STA. 94+37.93 TO STA. 95+65.00 (BEG. BRIDGE)
- L- STA. 96+35.00 (END BRIDGE) TO STA. 98+83.90 (BEGIN BOARDWALK)

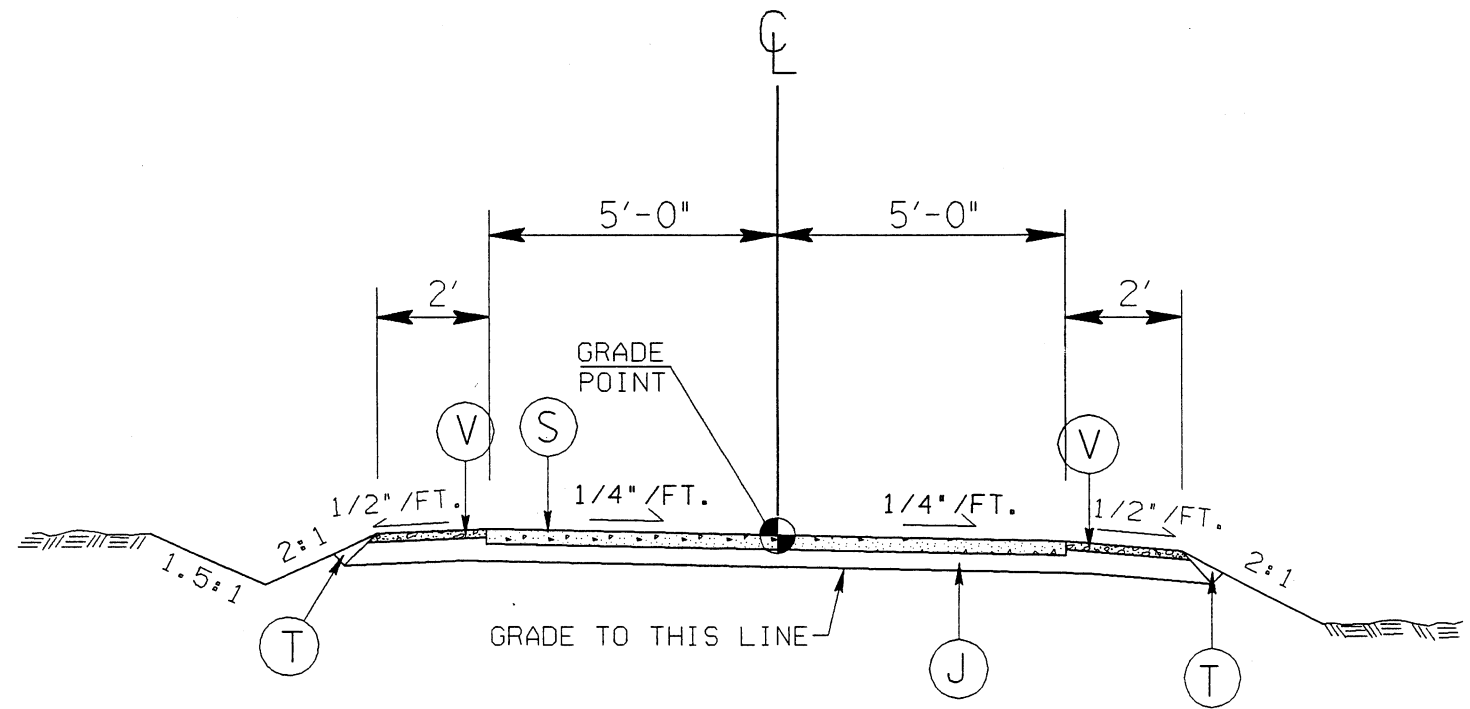

**TYPICAL SECTION NO. 2**

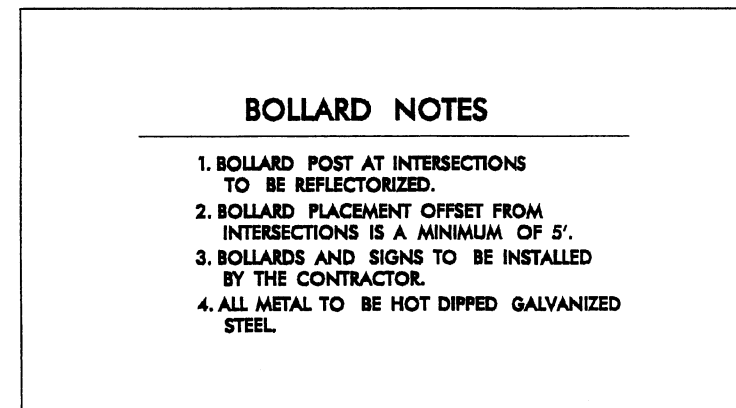
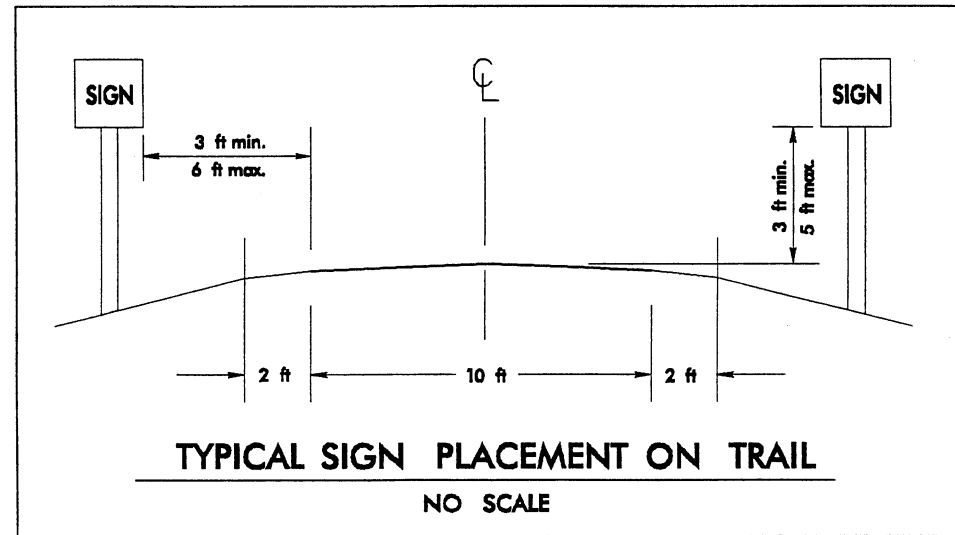
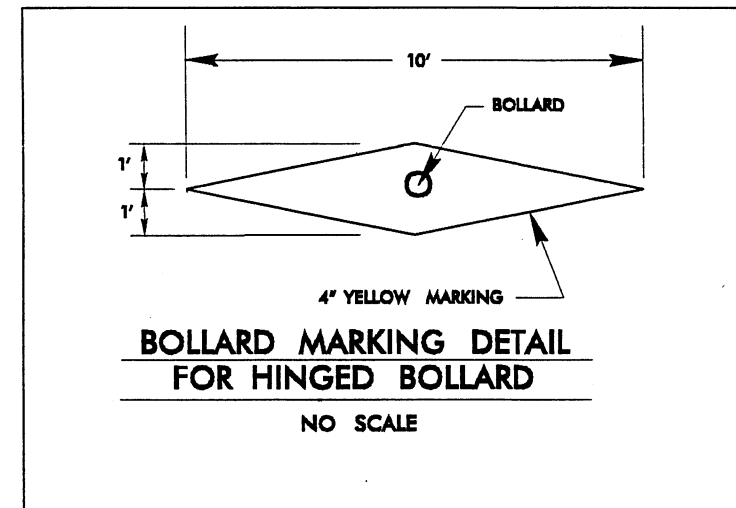
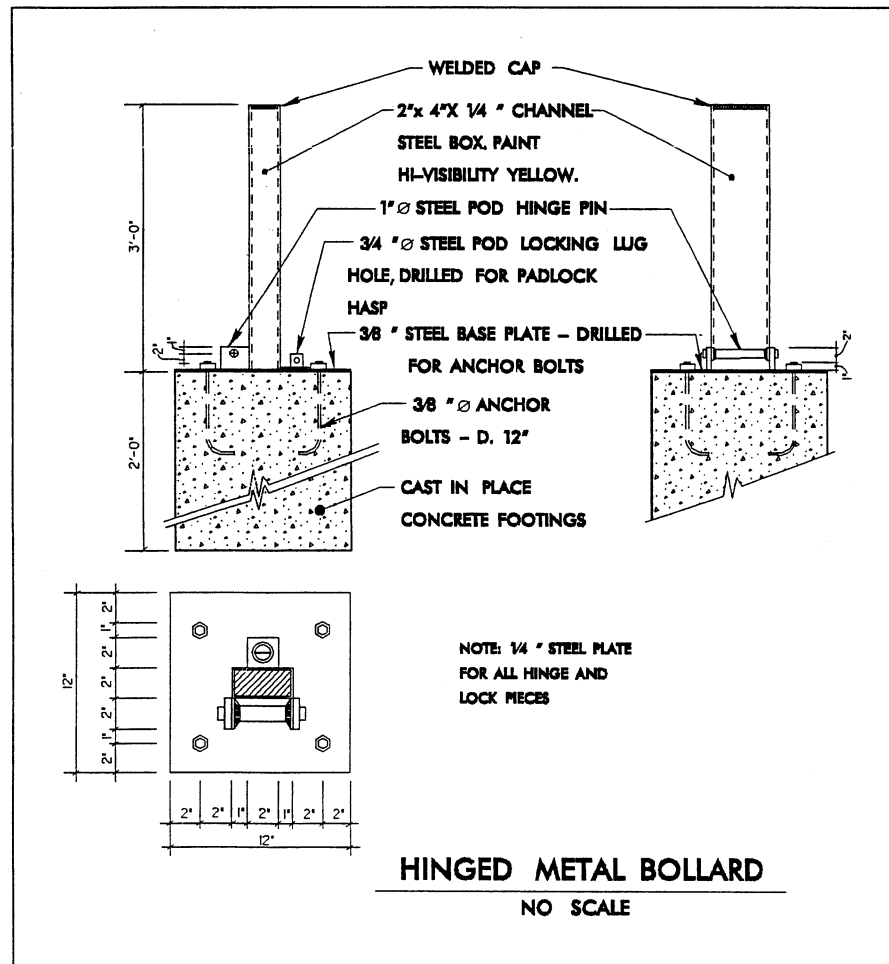
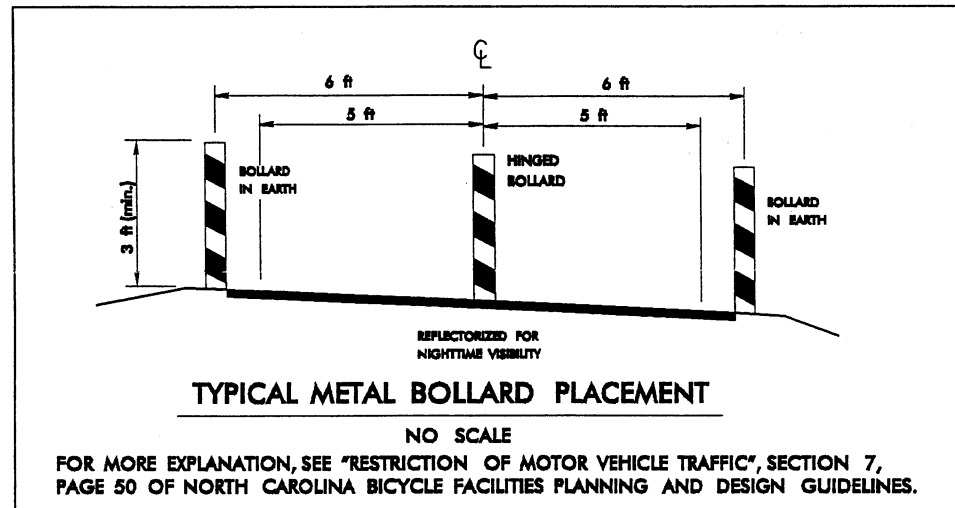
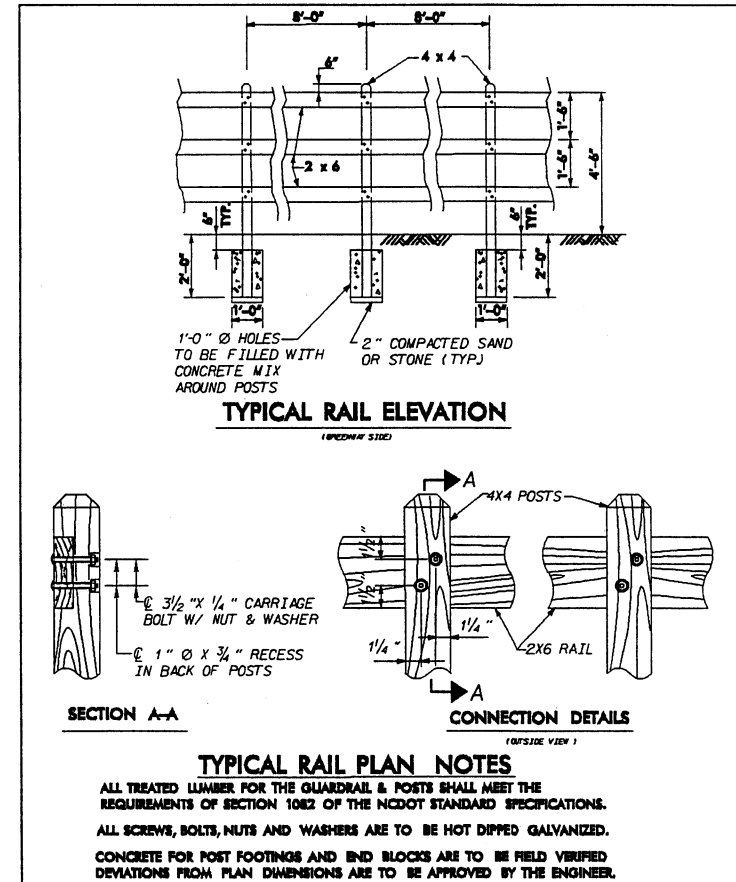
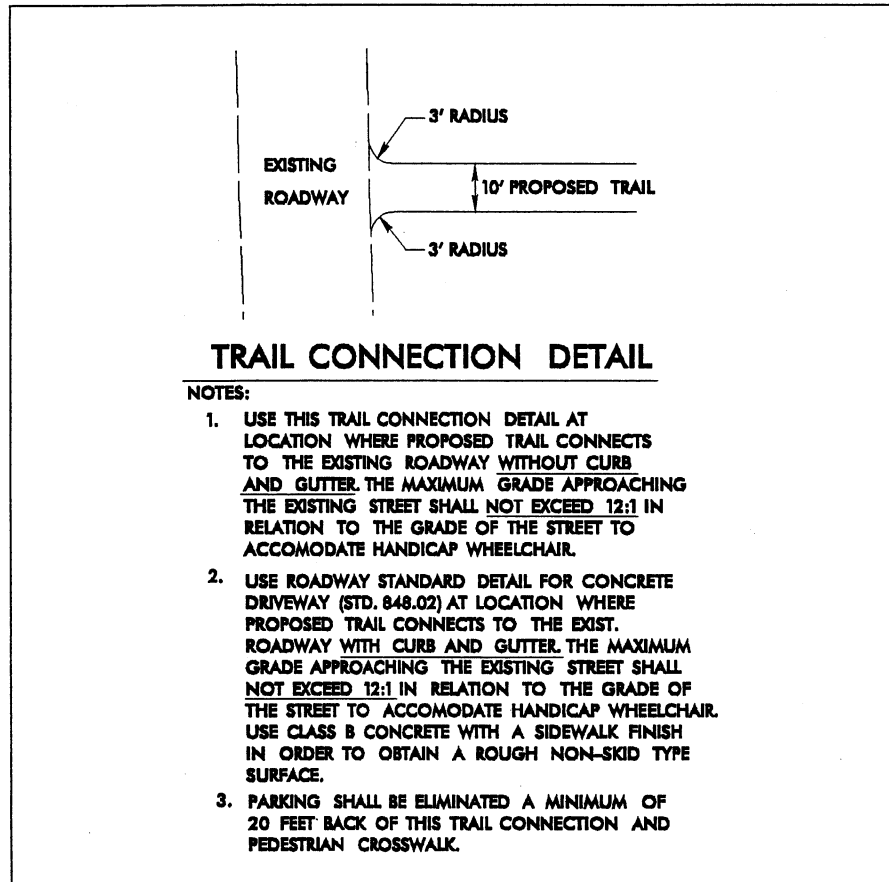
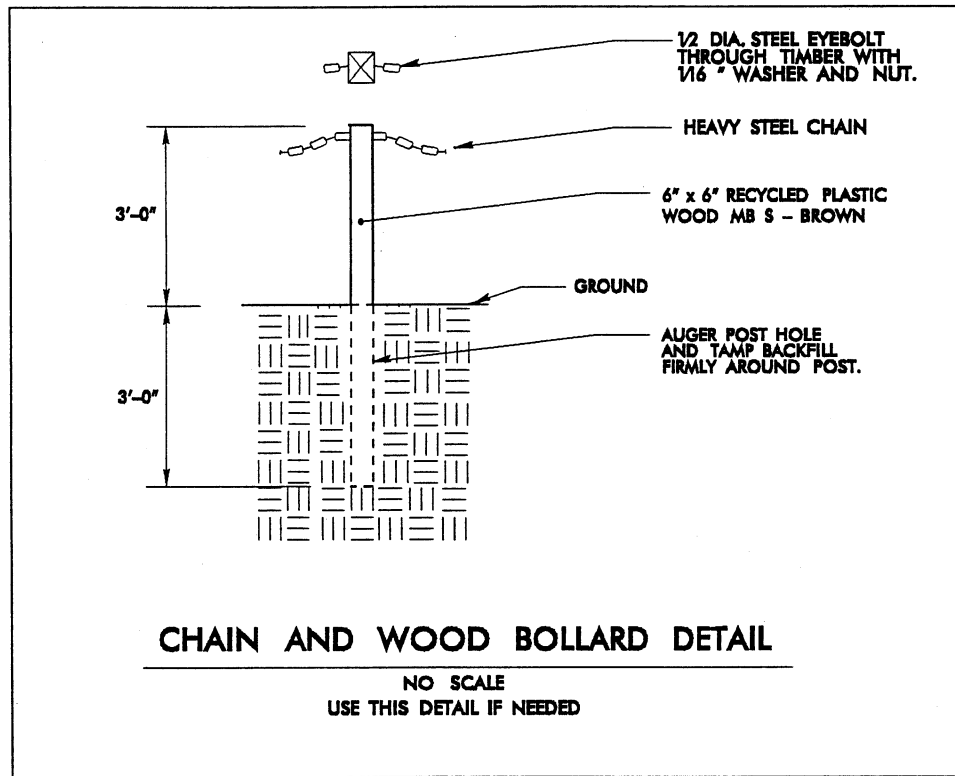

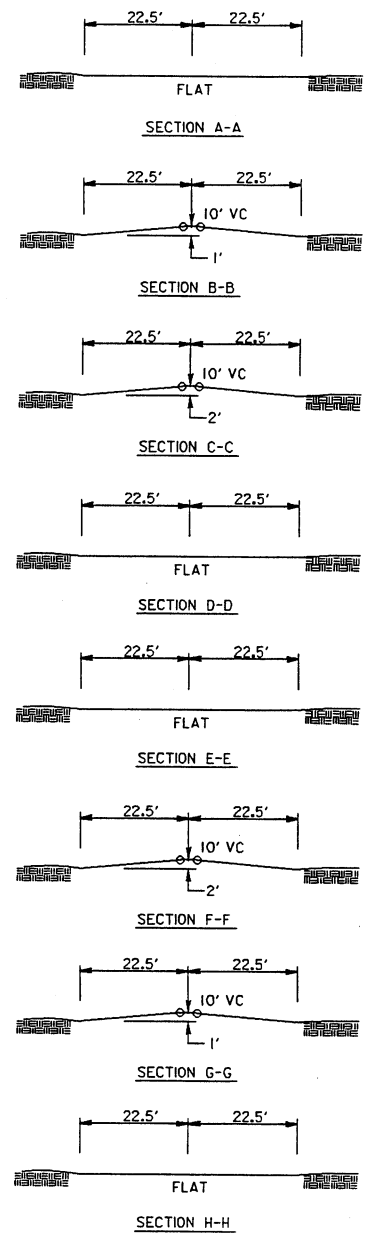
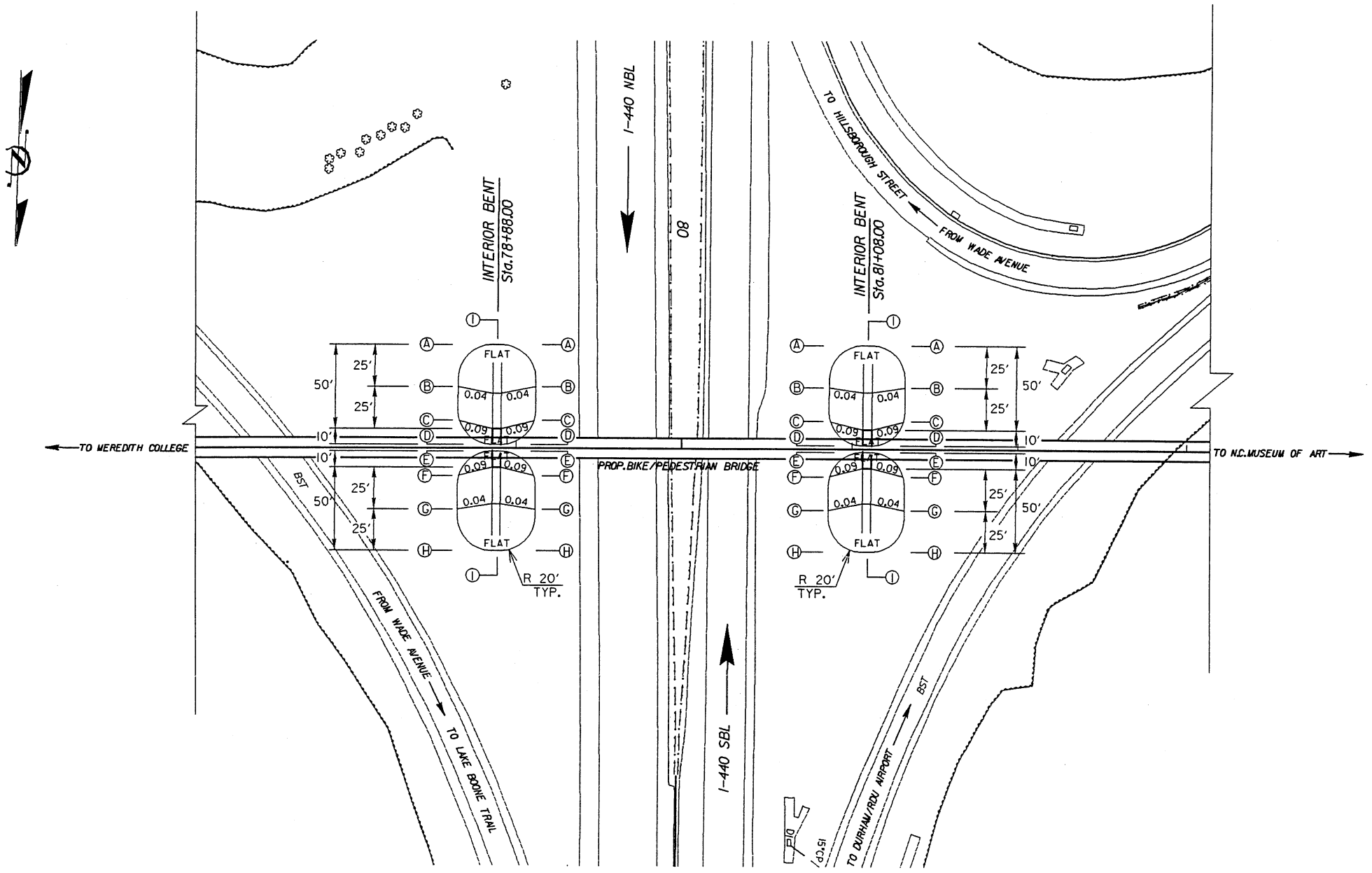

### EARTH BERM PIER PROTECTION

NTS

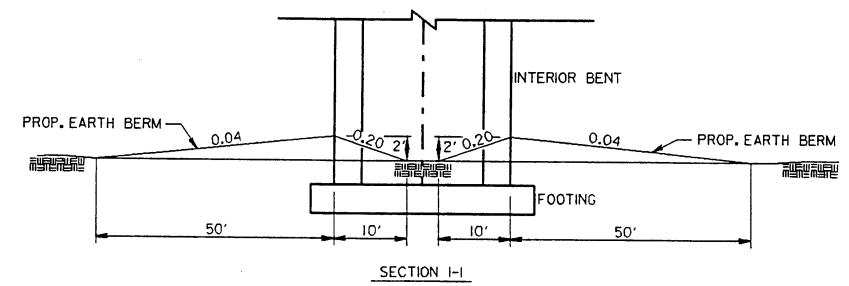

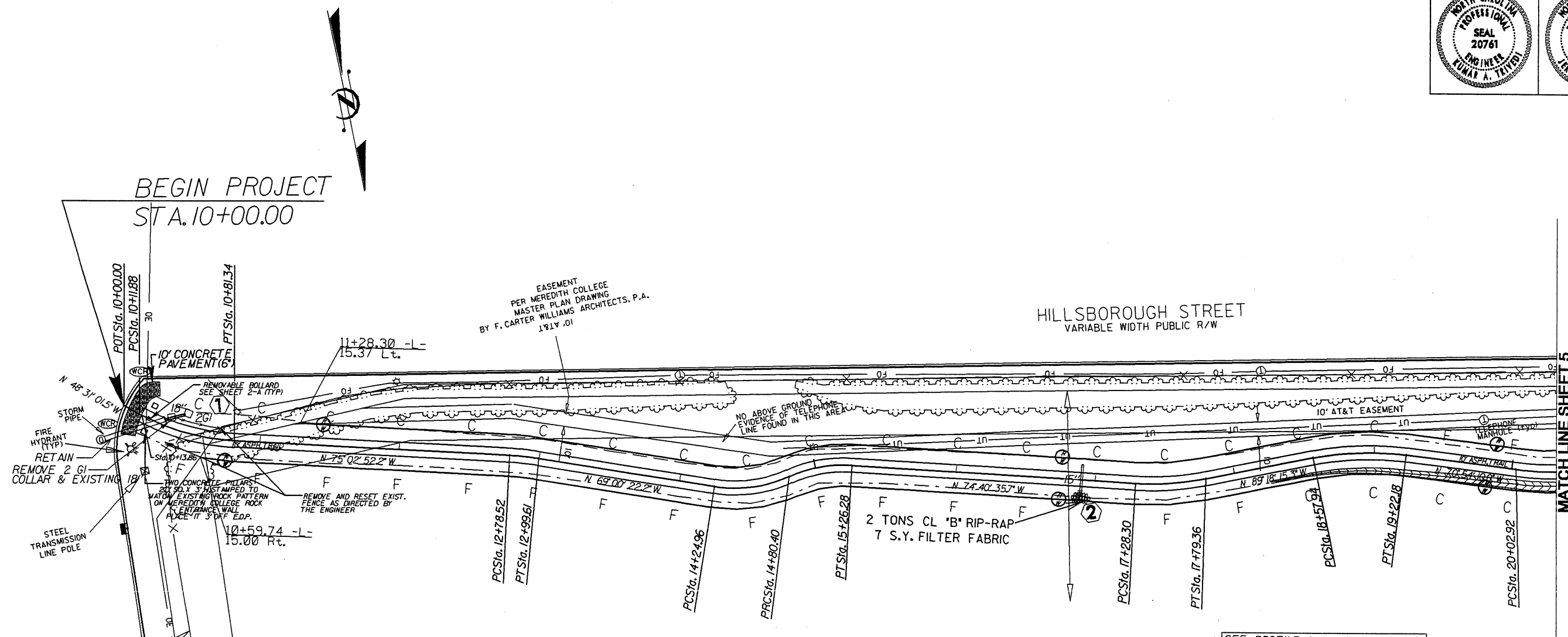

BEGIN PROJECT  
STA. 10+00.00

HILLSBOROUGH STREET  
VARIABLE WIDTH PUBLIC R/W

MEREDITH COLLEGE PROPERTY

**DATUM DESCRIPTION**  
 CHAINLINK FENCE LOCALIZED COORDINATE SYSTEM DEVELOPED FOR THIS PROJECT IS BASED ON THE STATE PLANE COORDINATES ESTABLISHED BY NCDS FOR MONUMENT "MERCOLL" WITH NAD 83 STATE PLANE GRID COORDINATES OF NORTHING: 746248.960(1) EASTING: 2090920.250(1) THE AVERAGE COMBINED GRID FACTOR USED ON THIS PROJECT (GROUND TO GRID) IS: 0.999896113 THE NAD LAMBERT GRID BEARING AND LOCALIZED HORIZONTAL GROUND DISTANCE FROM "MERCOLL" TO L- STATION 10+00 IS S 49° 33' 08.55" E 3,495.42 FT. ALL LINEAR DIMENSIONS ARE LOCALIZED HORIZONTAL DISTANCES VERTICAL DATUM USED IS NGVD 29

PI Sta 10+47.24 Δ = 26° 31' 51.82" (LT) D = 38' 11" 49.87" L = 69.46 T = 35.36 R = 150.00	PI Sta 12+89.07 Δ = 6° 02' 29.20" (RT) D = 28' 38" 52.40" L = 21.09 T = 10.55 R = 200.00	PI Sta 14+53.49 Δ = 33° 25' 54.85" (LT) D = 60' 18" 40.85" L = 55.43 T = 28.53 R = 95.00	PI Sta 15+03.80 Δ = 27° 40' 32.05" (RT) D = 60' 18" 40.85" L = 45.89 T = 23.40 R = 95.00	PI Sta 17+53.97 Δ = 14° 37' 38.93" (LT) D = 28' 38" 52.40" L = 51.06 T = 25.67 R = 200.00	PI Sta 18+90.34 Δ = 18° 24' 05.23" (RT) D = 28' 38" 52.40" L = 64.23 T = 32.40 R = 200.00	PI Sta 20+26.51 Δ = 13° 27' 07.20" (LT) D = 28' 38" 52.40" L = 46.96 T = 23.59 R = 200.00
--	---	---	---	--	--	--

NOTE: PIPE MATERIAL CAN BE RCP, HDP, OR CMP EXCEPT WHERE MATERIAL IS SPECIFIED ON THE PLANS.  
 NOTES:  
 1. SEE SHEET PF-1 FOR PROFILE  
 2. SEE SHEETS X-1 - X-4 FOR CROSS-SECTIONS



PI Sta 24+22.31 Δ = 25° 38' 31.75" (LT) D = 57' 17" 44.81" L = 44.75 T = 22.76 R = 100.00	PI Sta 25+10.46 Δ = 34° 32' 02.46" (RT) D = 57' 17" 44.81" L = 60.27 T = 31.08 R = 100.00
--	--

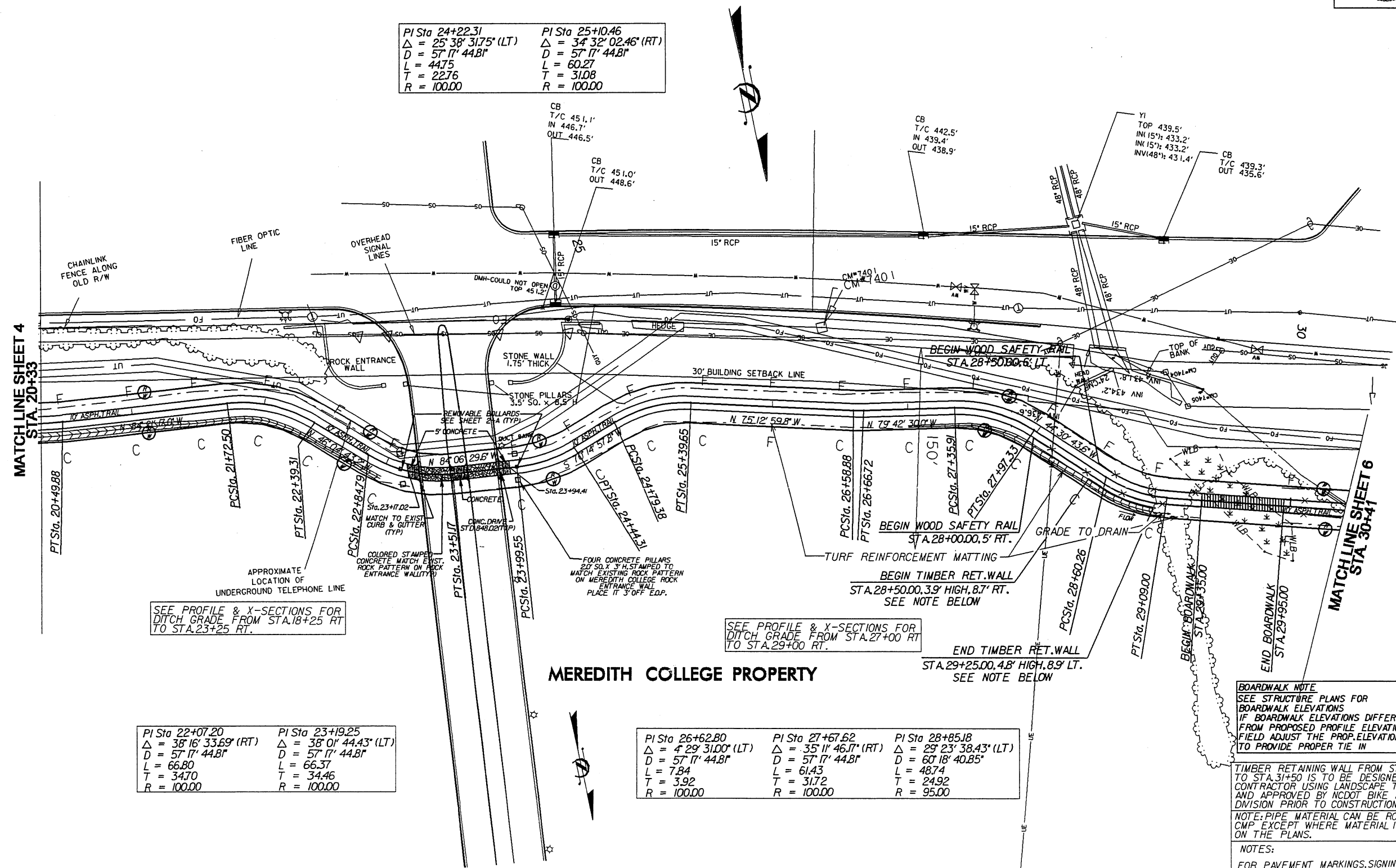

SEE PROFILE & X-SECTIONS FOR DITCH GRADE FROM STA.18+25 RT TO STA.23+25 RT.

SEE PROFILE & X-SECTIONS FOR DITCH GRADE FROM STA.27+00 RT TO STA.29+00 RT.

PI Sta 22+07.20 Δ = 38° 16' 33.69" (RT) D = 57' 17" 44.81" L = 66.80 T = 34.70 R = 100.00	PI Sta 23+19.25 Δ = 38° 01' 44.43" (LT) D = 57' 17" 44.81" L = 66.37 T = 34.46 R = 100.00
--	--

PI Sta 26+62.80 Δ = 4° 29' 31.00" (LT) D = 57' 17" 44.81" L = 7.84 T = 3.92 R = 100.00	PI Sta 27+67.62 Δ = 35° 11' 46.17" (RT) D = 57' 17" 44.81" L = 61.43 T = 31.72 R = 100.00	PI Sta 28+85.18 Δ = 29° 23' 38.43" (LT) D = 60' 18" 40.85" L = 48.74 T = 24.92 R = 95.00
---	--	---

**BOARDWALK NOTE**  
SEE STRUCTURE PLANS FOR BOARDWALK ELEVATIONS. IF BOARDWALK ELEVATIONS DIFFER FROM PROPOSED PROFILE ELEVATIONS FIELD ADJUST THE PROP. ELEVATIONS TO PROVIDE PROPER TIE IN.

TIMBER RETAINING WALL FROM STA.28+50 TO STA.31+50 IS TO BE DESIGNED BY THE CONTRACTOR USING LANDSCAPE TIMBER AND APPROVED BY NCDOT BIKE AND PED. DIVISION PRIOR TO CONSTRUCTION.

NOTE: PIPE MATERIAL CAN BE RCP, HDP, OR CMP EXCEPT WHERE MATERIAL IS SPECIFIED ON THE PLANS.

**NOTES:**  
FOR PAVEMENT MARKINGS, SIGNING AND BOLLARDS, SEE TRAFFIC CONTROL PLANS AND SHEET 2-A.  
1. SEE SHEET PF-1 FOR PROFILE  
2. SEE SHEETS X-5- X-10 FOR CROSS-SECTIONS

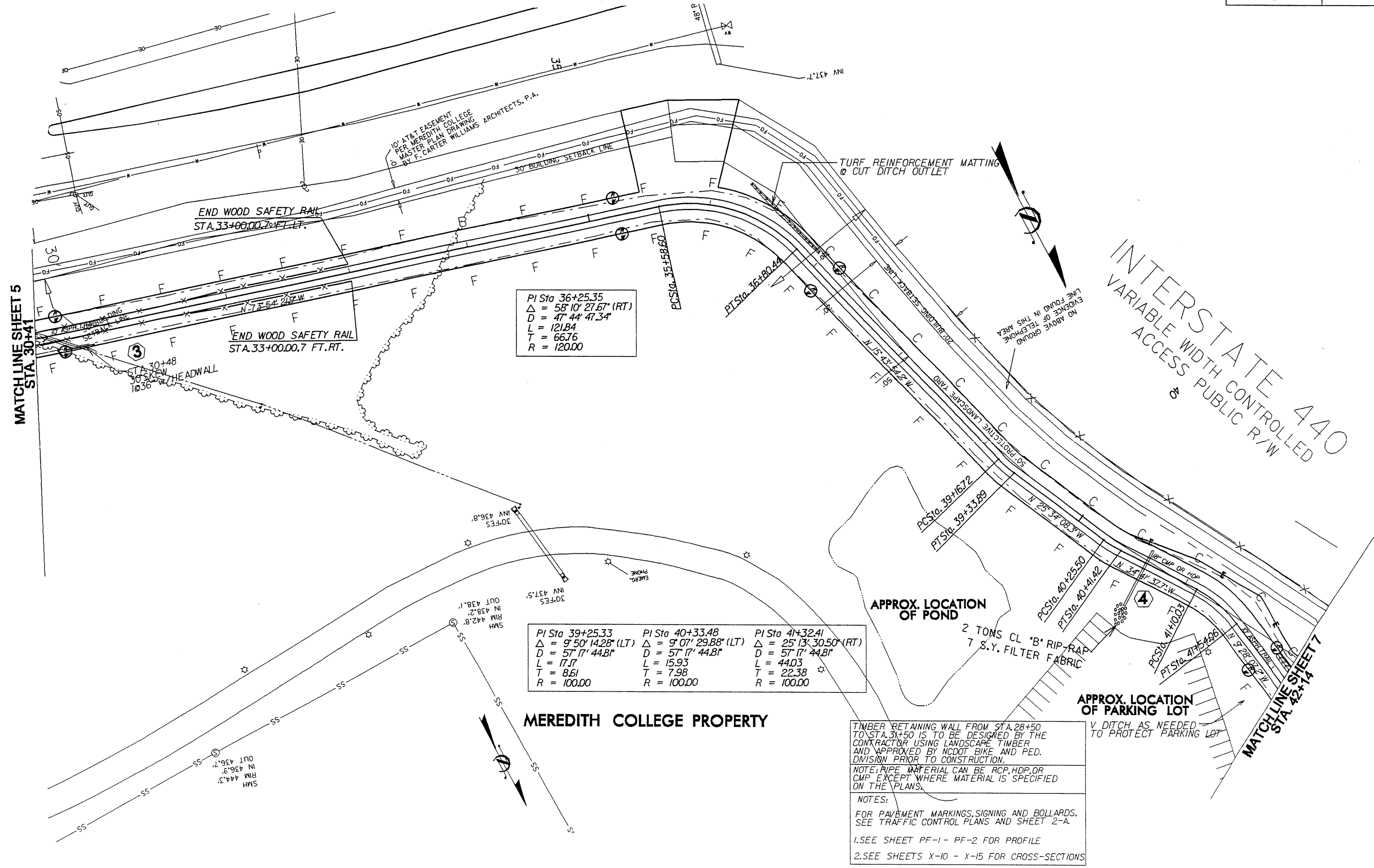

PI Sta 36+25.35
$\Delta = 58' 10' 27.67''$ (RT)
$D = 47' 44' 47.34''$
$L = 121.84$
$T = 66.76$
$R = 120.00$

PI Sta 39+25.33	PI Sta 40+33.48	PI Sta 41+32.41
$\Delta = 9' 50' 14.28''$ (LT)	$\Delta = 9' 07' 29.88''$ (LT)	$\Delta = 25' 13' 30.50''$ (RT)
$D = 57' 17' 44.81''$	$D = 57' 17' 44.81''$	$D = 57' 17' 44.81''$
$L = 17.17$	$L = 15.93$	$L = 44.03$
$T = 8.61$	$T = 7.98$	$T = 22.38$
$R = 100.00$	$R = 100.00$	$R = 100.00$

TIMBER RETAINING WALL FROM STA. 28+50 TO STA. 31+50 IS TO BE DESIGNED BY THE CONTRACTOR USING LANDSCAPE TIMBER AND APPROVED BY NCDOT BIKE AND PED. DIVISION PRIOR TO CONSTRUCTION.

NOTE: PIPE MATERIAL CAN BE RCP, HDP, OR CMP EXCEPT WHERE MATERIAL IS SPECIFIED ON THE PLANS.

NOTES:

FOR PAVEMENT MARKINGS, SIGNING AND BOLLARDS, SEE TRAFFIC CONTROL PLANS AND SHEET 2-A.

1. SEE SHEET PF-1 - PF-2 FOR PROFILE

2. SEE SHEETS X-10 - X-15 FOR CROSS-SECTIONS

PI Sta 42+82.67 Δ = 15° 24' 58.40" (RT) D = 60° 18' 40.85" L = 25.56 T = 12.86 R = 95.00	PI Sta 44+26.37 Δ = 3° 19' 50.92" (RT) D = 60° 18' 40.85" L = 5.52 T = 2.76 R = 95.00	PI Sta 45+41.38 Δ = 1° 52' 06.32" (LT) D = 60° 18' 40.85" L = 3.10 T = 1.55 R = 95.00
---	--	--

PI Sta 46+94.67 Δ = 1° 56' 06.64" (LT) D = 60° 18' 40.85" L = 3.21 T = 1.60 R = 95.00	PI Sta 49+59.66 Δ = 5° 04' 55.69" (LT) D = 1° 08' 45.30" L = 443.50 T = 221.90 R = 5,000.00
--	--



# INTERSTATE 440

VARIABLE WIDTH CONTROLLED  
ACCESS PUBLIC R/W

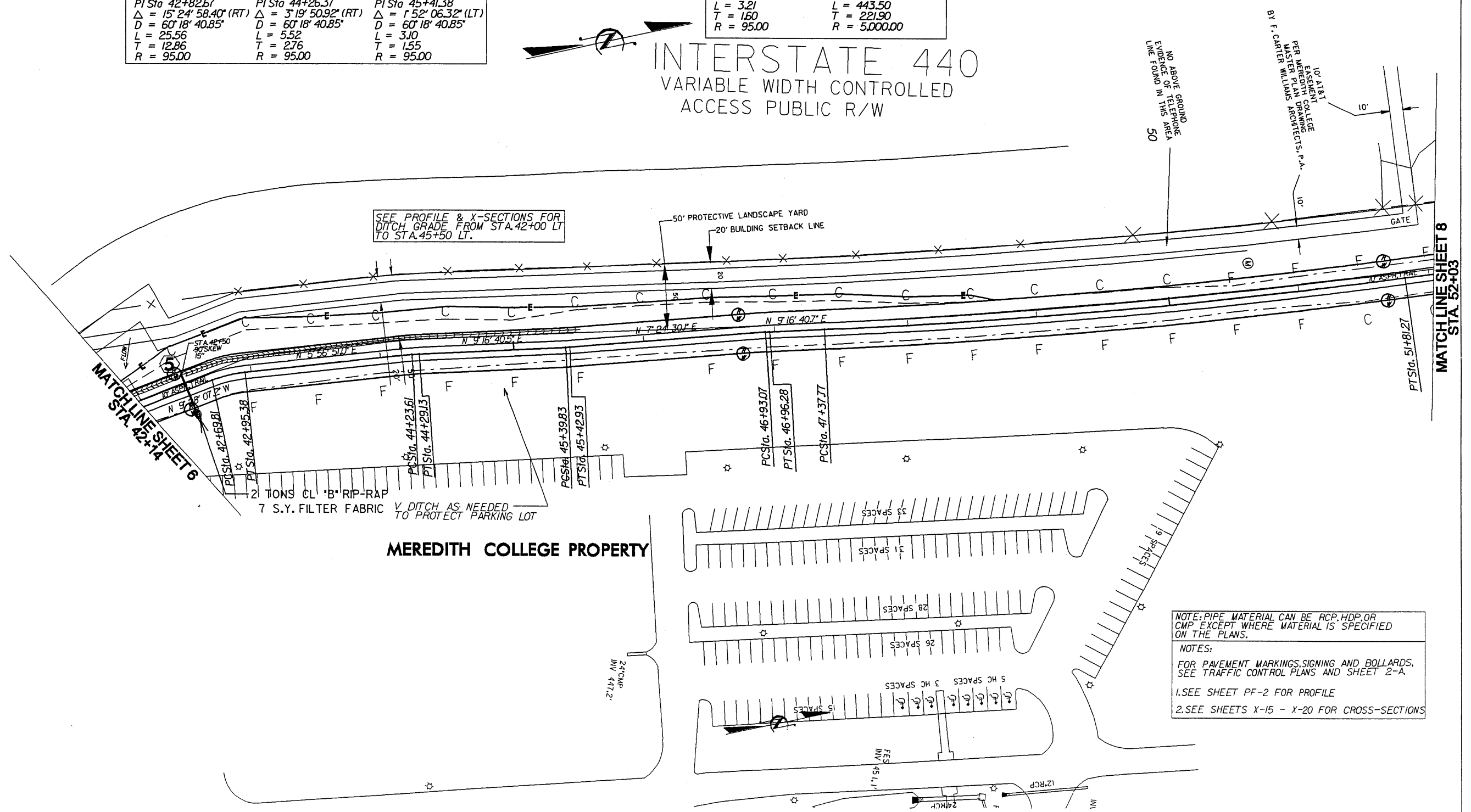

SEE PROFILE & X-SECTIONS FOR  
DITCH GRADE FROM STA. 42+00 LT  
TO STA. 45+50 LT.

MATCH LINE SHEET 6  
STA. 42+14

MATCH LINE SHEET 8  
STA. 52+03

MEREDITH COLLEGE PROPERTY

NOTE: PIPE MATERIAL CAN BE RCP, HDP, OR  
CMP, EXCEPT WHERE MATERIAL IS SPECIFIED  
ON THE PLANS.

NOTES:  
FOR PAVEMENT MARKINGS, SIGNING AND BOLLARDS,  
SEE TRAFFIC CONTROL PLANS AND SHEET 2-A.  
1. SEE SHEET PF-2 FOR PROFILE  
2. SEE SHEETS X-15 - X-20 FOR CROSS-SECTIONS

# INTERSTATE 440

VARIABLE WIDTH CONTROLLED  
ACCESS PUBLIC R/W



PI Sta 59+57.68 Δ = 63° 45' 47.04" (RT) D = 60' 18" 40.85" L = 105.72 T = 59.09 R = 95.00	PI Sta 61+39.78 Δ = 42° 30' 55.92" (LT) D = 60' 18" 40.85" L = 70.49 T = 36.96 R = 95.00	PI Sta 63+03.22 Δ = 31° 10' 41.94" (LT) D = 38' 11" 49.87" L = 81.62 T = 41.85 R = 150.00
--	---	--

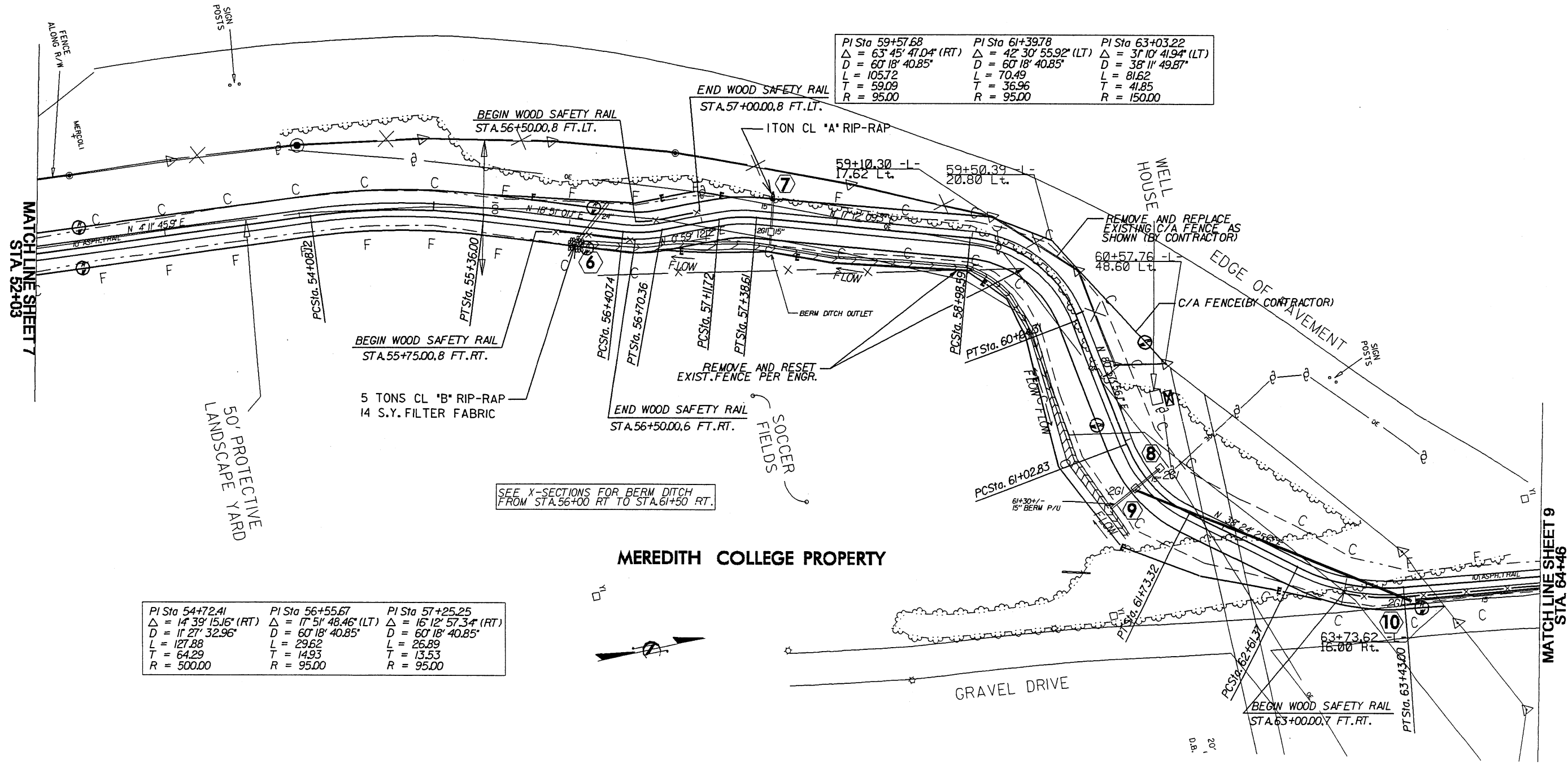

PI Sta 54+72.41 Δ = 14° 39' 15.16" (RT) D = 11' 27" 32.96" L = 127.88 T = 64.29 R = 500.00	PI Sta 56+55.67 Δ = 17° 51' 48.46" (LT) D = 60' 18" 40.85" L = 29.62 T = 14.93 R = 95.00	PI Sta 57+25.25 Δ = 16° 12' 57.34" (RT) D = 60' 18" 40.85" L = 26.89 T = 13.53 R = 95.00
---	---	---

SEE X-SECTIONS FOR BERM DITCH FROM STA.56+00 RT TO STA.61+50 RT.

## MEREDITH COLLEGE PROPERTY



NOTE: PIPE MATERIAL CAN BE RCP, HDP, OR CMP EXCEPT WHERE MATERIAL IS SPECIFIED ON THE PLANS.

NOTES:

FOR PAVEMENT MARKINGS, SIGNING AND BOLLARDS, SEE TRAFFIC CONTROL PLANS AND SHEET 2-A.

1. SEE SHEET PF-2 - PF-3 FOR PROFILE

2. SEE SHEETS X-20 - X-27 FOR CROSS-SECTIONS

5/14/99  
 I:\JUN-2003\447  
 \E3806AA\_Merid-Ar-Pln\Plan\E3806AA89.psh  
 6/1/99  
 6/1/99

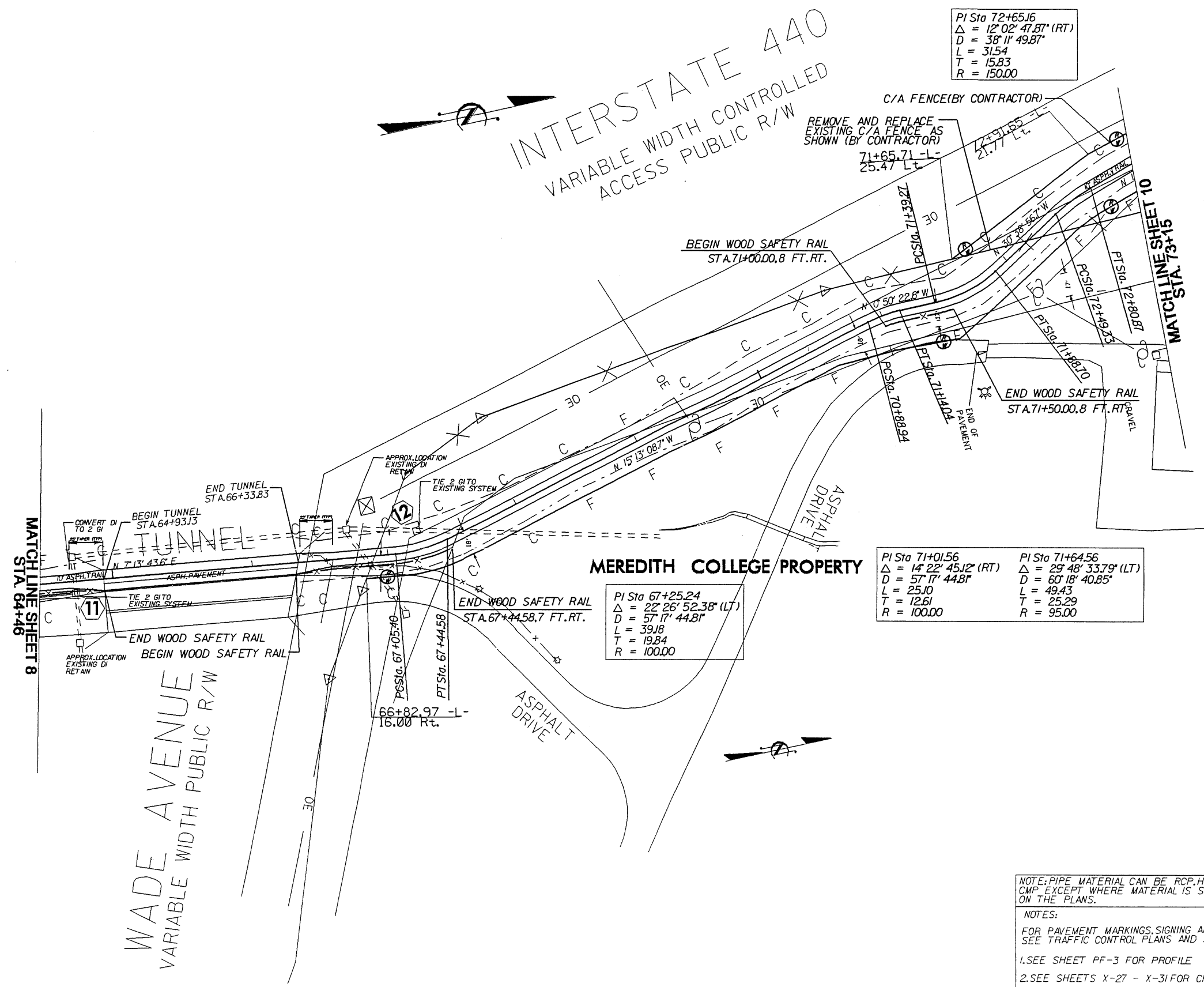

NOTE: PIPE MATERIAL CAN BE RCP, HDP, OR CMP EXCEPT WHERE MATERIAL IS SPECIFIED ON THE PLANS.

NOTES:  
 FOR PAVEMENT MARKINGS, SIGNING AND BOLLARDS, SEE TRAFFIC CONTROL PLANS AND SHEET 2-A.  
 1. SEE SHEET PF-3 FOR PROFILE  
 2. SEE SHEETS X-27 - X-31 FOR CROSS-SECTIONS

PROJECT REFERENCE NO. E-3806AA		SHEET NO. 10	
R/W SHEET NO.			
ROADWAY DESIGN ENGINEER KUNAY A. TRIVEDY PROFESSIONAL SEAL 20761		HYDRAULICS ENGINEER JERRY L. INDSBY PROFESSIONAL SEAL 15833	

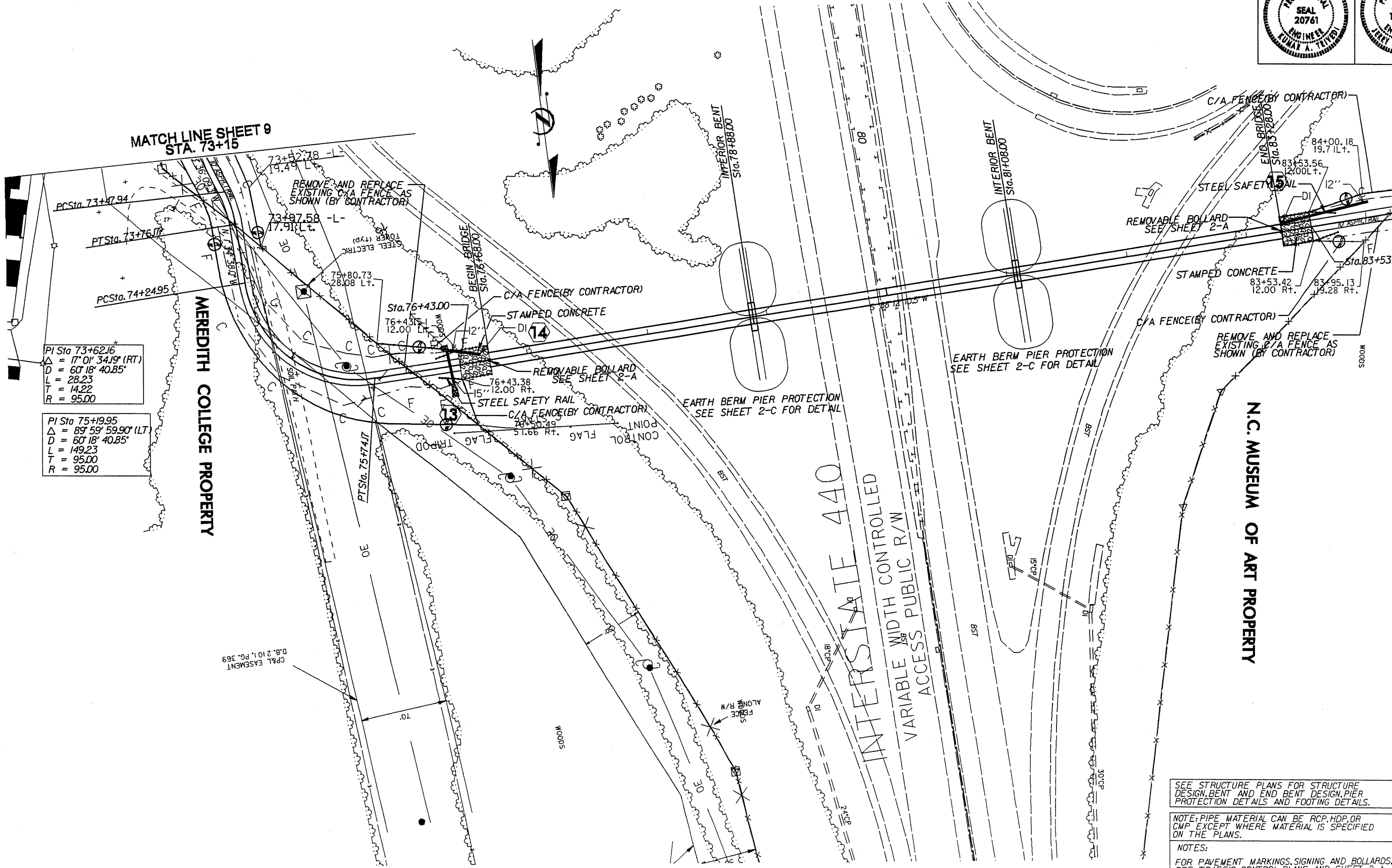

PI Sta 73+62.16  
 $\Delta = 17^{\circ} 0' 34.19''$  (RT)  
 $D = 60^{\circ} 18' 40.85''$   
 $L = 28.23$   
 $T = 14.22$   
 $R = 95.00$

PI Sta 75+19.95  
 $\Delta = 89^{\circ} 59' 59.90''$  (LT)  
 $D = 60^{\circ} 18' 40.85''$   
 $L = 149.23$   
 $T = 95.00$   
 $R = 95.00$

SEE STRUCTURE PLANS FOR STRUCTURE DESIGN, BENT AND END BENT DESIGN, PIER PROTECTION DETAILS AND FOOTING DETAILS.

NOTE: PIPE MATERIAL CAN BE RCP, HDP, OR CMP EXCEPT WHERE MATERIAL IS SPECIFIED ON THE PLANS.

NOTES:  
 FOR PAVEMENT MARKINGS, SIGNING AND BOLLARDS, SEE TRAFFIC CONTROL PLANS AND SHEET 2-A.

1. SEE SHEET PF-3 - PF-4 FOR PROFILE  
 2. SEE SHEETS X-31 - X-35 FOR CROSS-SECTIONS

Revised 8-15-03

PI Sta 85+02.95 Δ = 41° 52' 24.22" (LT) D = 38' 11" 49.87" L = 109.62 T = 57.39 R = 150.00 SE = .02	PI Sta 85+96.12 Δ = 35° 58' 45.84" (RT) D = 60' 18" 40.85" L = 59.66 T = 30.85 R = 95.00 SE = .02	PI Sta 86+85.79 Δ = 23° 42' 40.07" (LT) D = 60' 18" 40.85" L = 39.31 T = 19.94 R = 95.00 SE = .02	PI Sta 87+83.48 Δ = 31° 12' 01.91" (LT) D = 60' 18" 40.85" L = 51.73 T = 26.53 R = 95.00 SE = .02	PI Sta 91+67.76 Δ = 152° 07' 42.57" (RT) D = 76' 23' 39.74" L = 199.14 T = 302.25 R = 75.00 SE = .02	PI Sta 91+54.07 Δ = 24° 31' 30.17" (RT) D = 28' 38' 52.40" L = 85.61 T = 43.47 R = 200.00 SE = .02
---	---	---	---	--	--

PI Sta 92+77.74 Δ = 12° 47' 12.73" (RT) D = 28' 38' 52.40" L = 44.63 T = 22.41 R = 200.00 SE = .02	PI Sta 93+98.41 Δ = 51° 25' 35.97" (LT) D = 60' 18" 40.85" L = 85.27 T = 45.75 R = 95.00 SE = .02	PI Sta 94+99.25 Δ = 113° 45' 35.57" (LT) D = 143' 14" 22.02" L = 79.42 T = 61.31 R = 40.00 SE = .02	PI Sta 95+69.09 Δ = 36° 40' 22.50" (RT) D = 114' 35' 29.61" L = 32.00 T = 16.57 R = 50.00 SE = .02
--	---	---	--

SEE PROFILE & X-SECTIONS FOR DITCH GRADE FROM STA. 85+00 LT TO STA. 87+30 LT.

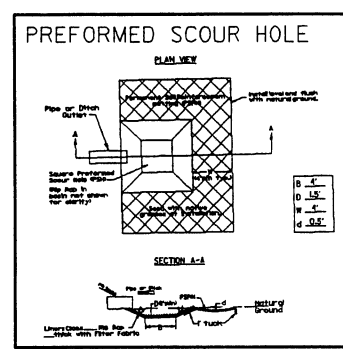
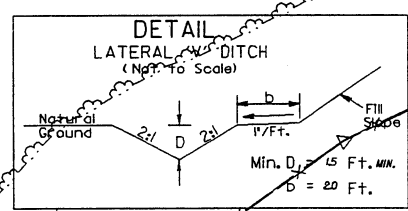

SEE X-SECTIONS FOR BERM DITCH FROM STA. 102+00 RT TO STA. 108+00 RT.

MATCHLINE SHEET 10 STA. 84+24

MATCHLINE SHEET 12 STA. 104+33

N.C. MUSEUM OF ART PROPERTY

PROVIDE EXTRA 1" OF ASPHALT/CONCRETE PAVEMENT ON BOTH SIDES OF THE TRAIL FROM STA. 88+65.51 TO STA. 90+64.64 AND FROM STA. 94+37.93 TO STA. 95+65 (BEG. BRG.) WITH 15" PAPER PROVIDE ONLY 1" SELECT MATERIAL SHOULDERS AT THESE LOCATIONS

- NOTES:
- FOR PAVEMENT MARKINGS, SIGNING AND BOLLARDS, SEE TRAFFIC CONTROL PLANS AND SHEET 2-A.
  - SEE SHEETS X-35 - X-44 FOR CROSS-SECTIONS
  - SEE SHEETS S- - S- FOR RETAINING WALL
  - SEE SHEETS S- - S- FOR BOARDWALK

BOARDWALK NOTE  
SEE STRUCTURE PLANS FOR BOARDWALK ELEVATIONS  
IF BOARDWALK ELEVATIONS DIFFER FROM PROPOSED PROFILE ELEVATIONS FIELD ADJUST THE PROP. ELEVATIONS TO PROVIDE PROPER TIE IN

PI Sta 96+88.63 Δ = 64° 10' 16.34" (LT) D = 60' 18" 40.85" L = 106.40 T = 59.56 R = 95.00 SE = .02	PI Sta 98+11.54 Δ = 53° 46' 45.23" (RT) D = 38' 11" 49.87" L = 140.79 T = 76.07 R = 150.00 SE = .02	PI Sta 99+29.40 Δ = 58° 26' 10.77" (LT) D = 60' 18" 40.85" L = 96.89 T = 53.13 R = 95.00 SE = .02
--	---	---

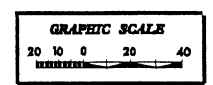

REVISED 8-15-03

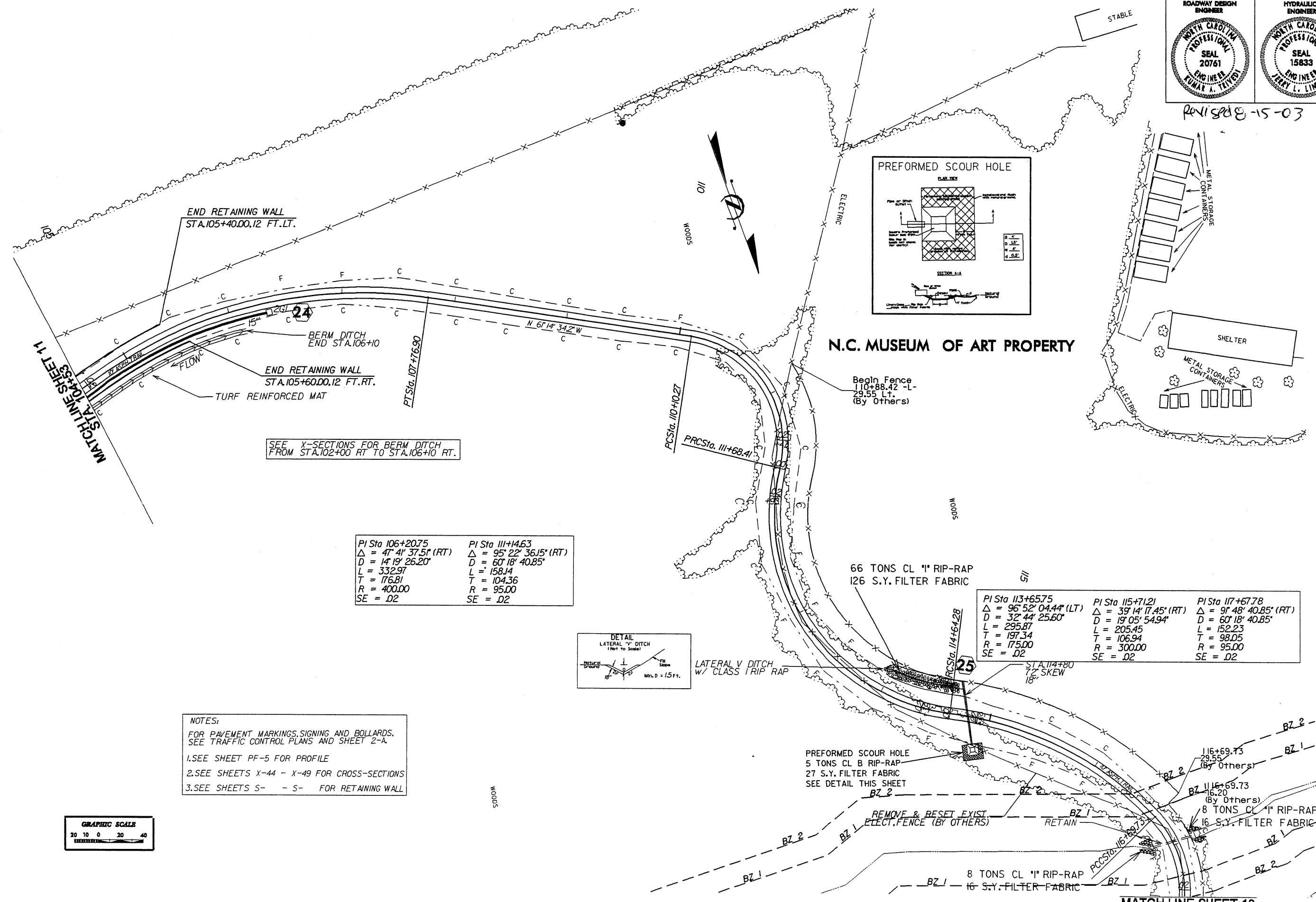

SEE X-SECTIONS FOR BERM DITCH FROM STA. 102+00 RT TO STA. 106+10 RT.

PI Sta 106+20.75 Δ = 47° 41' 37.5" (RT) D = 14° 19' 26.20" L = 332.97 T = 176.81 R = 400.00 SE = .02	PI Sta 111+14.63 Δ = 95° 22' 36.15" (RT) D = 60° 18' 40.85" L = 158.14 T = 104.36 R = 95.00 SE = .02
--	--

PI Sta 113+65.75 Δ = 96° 52' 04.44" (LT) D = 32° 44' 25.60" L = 295.87 T = 197.34 R = 175.00 SE = .02	PI Sta 115+71.21 Δ = 39° 14' 17.45" (RT) D = 19° 05' 54.94" L = 205.45 T = 106.94 R = 300.00 SE = .02	PI Sta 117+67.78 Δ = 91° 48' 40.85" (RT) D = 60° 18' 40.85" L = 152.23 T = 98.05 R = 95.00 SE = .02
---	---	---

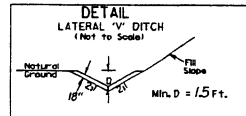

NOTES:  
FOR PAYMENT MARKINGS, SIGNING AND BOLLARDS, SEE TRAFFIC CONTROL PLANS AND SHEET 2-A.  
1. SEE SHEET PF-5 FOR PROFILE  
2. SEE SHEETS X-44 - X-49 FOR CROSS-SECTIONS  
3. SEE SHEETS S- - S- FOR RETAINING WALL

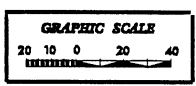

5/14/99  
15-AUG-2003 13:52  
I:\E3806AA\1on\E3806AA\12.psh

MATCH LINE SHEET 13  
STA. 117+42





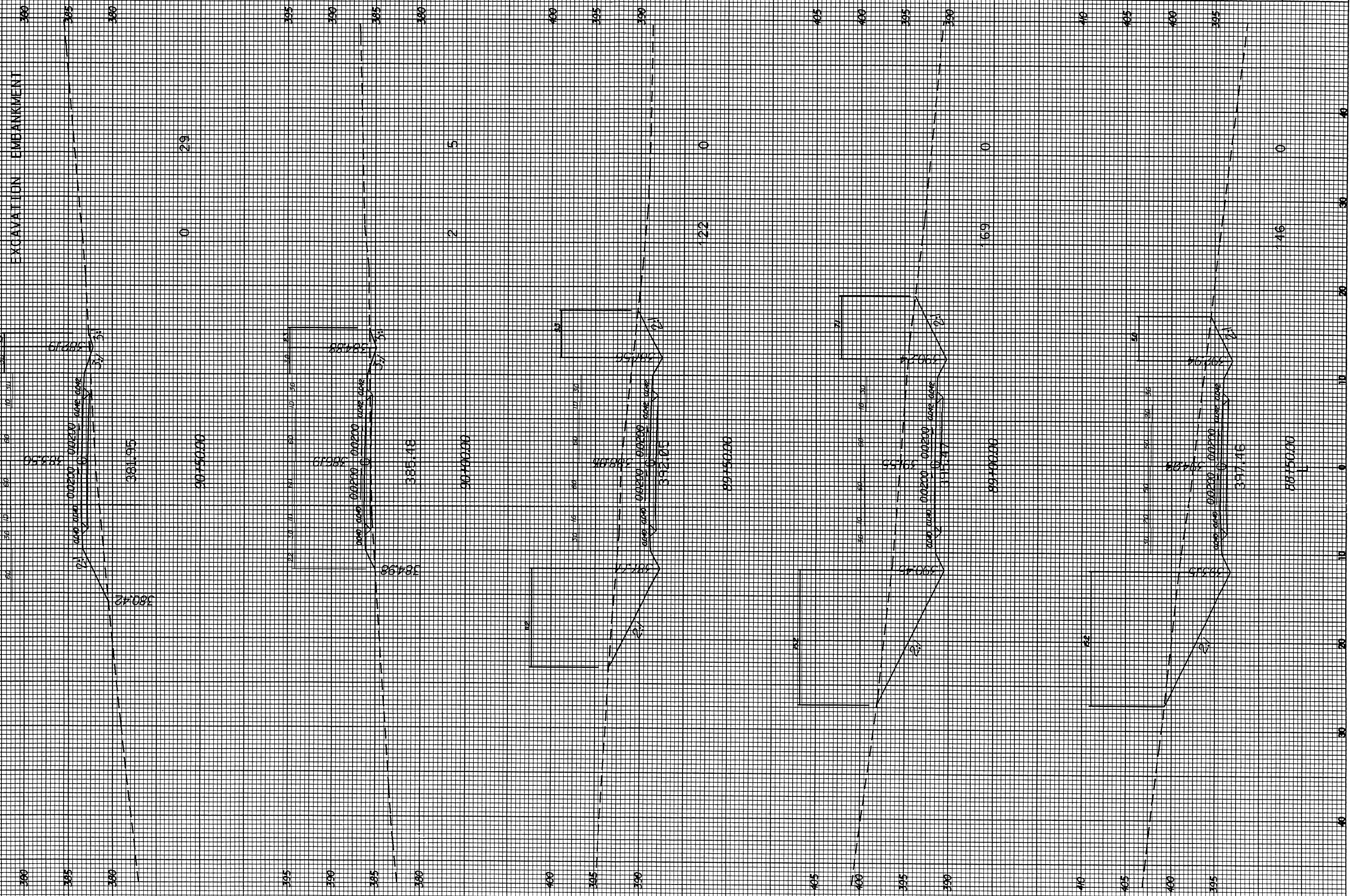
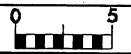



EXCAVATION EMBANKMENT DIDE

