



STATE OF NORTH CAROLINA  
DEPARTMENT OF TRANSPORTATION

MICHAEL F. EASLEY  
GOVERNOR

LYNDO TIPPETT  
SECRETARY

September 16, 2004

MEMORANDUM TO: Mr. H. Allen Pope, P.E.  
Division 3 Engineer

FROM: Philip S. Harris, III, P.E., Manager   
Office of the Natural Environment  
Project Development and  
Environmental Analysis Branch

SUBJECT: New Hanover County, Replace Bridge No. 10 over the Bradley  
Creek on SR 1411 (Wrightsville Avenue) in Wilmington; Work  
Order Number 8.2251101; TIP Number B-3496

Attached is the U. S. Army Corps of Engineers Nationwide Permit No. 23 and 33, CAMA Major Permit, and the general conditions for the Division of Water Quality 401 Certification for the construction of the above referenced project.

PSH/mka

Attachment

cc: Mr. Art McMillan, P.E.  
Mr. Omar Sultan  
Mr. Jay Bennett, P.E.  
Mr. David Chang, P.E.  
Mr. Randy Garris, P.E.  
Mr. Greg Perfetti, P.E.  
Mr. Njoroge Wainaina  
Mr. Mark Staley  
Mr. Mr. John F. Sullivan, III, FHWA  
Mr. Mason Herndon, Division 3 Environmental Officer

**MAILING ADDRESS:**  
NC DEPARTMENT OF TRANSPORTATION  
PROJECT DEVELOPMENT AND ENVIRONMENTAL ANALYSIS  
1598 MAIL SERVICE CENTER  
RALEIGH NC 27699-1598

TELEPHONE: 919-733-3141  
FAX: 919-733-9794  
**WEBSITE:** [WWW.DOT.ORG](http://WWW.DOT.ORG)

**LOCATION:**  
TRANSPORTATION BUILDING  
1 SOUTH WILMINGTON STREET  
RALEIGH NC

## **PROJECT COMMITMENTS**

**New Hanover County  
Bridge No. 10 Over Bradley Creek  
on SR 1411 (Wrightsville Avenue) in Wilmington  
Federal Aid Project No. BRSTP-1411(5)  
State Project No. 8.2251101  
WBS No. 33111.1.1  
TIP Project No. B-3496**

In addition to the standard CAMA, Nationwide Permit #23 and #33 Conditions, the general Nationwide Permit Conditions, Section 404 Only Conditions, Regional Conditions, State Consistency Conditions, General Certification Conditions, and Section 401 Conditions of Certification, the following special commitments have been agreed to by the NCDOT.

### **Commitments Developed During Project Development**

#### **Division 3 Construction**

An in-water construction moratorium is required from February 15 to June 30. Bradley Creek is located within a Primary Fish Nursery Area and may potentially provide habitat for anadromous fish spawning. The North Carolina Wildlife Resources Commission and the North Carolina Division of Marine Fisheries require the moratorium.

#### **Division 3 Construction/Structure Design Unit**

The existing bridge over Bradley Creek (Bridge No. 10) and the adjacent concrete utility structure will be removed in accordance with NCDOT's Best Management Practices for Bridge Demolition and Removal (Case 2 action). No temporary fill will be placed in Bradley Creek as a result of removing the existing bridge and utility structure. Based on preliminary information, top down construction will be used to construct the new bridge.

#### **Division 3 Construction**

Suitable habitat for the West Indian manatee is present in the project area. NCDOT will implement the US Fish and Wildlife Service (USFWS) "Precautions for General Construction in Areas Which May Be Used by West Indian Manatee". If these precautions are considered in all aspects of project construction, this project will not affect the West Indian manatee.

#### **Division 3 Construction**

NCDOT has agreed that the existing fence on the south side of SR 1411 (Wrightsville Avenue) just east of Softwind Way will not be disturbed during construction of the proposed project. In addition, the two trees in front of the house on the northwest corner of the Hooker Road/Wrightsville Avenue intersection will not be disturbed during construction as well.

## **Commitments developed during Permitting**

### **PDEA- Natural Environment Engineering Unit/ Division 3 Construction**

The Project Development and Environmental Analysis, Office of Natural Environment Engineering Unit shall provide assistance with construction for any on-site wetland mitigation, stream mitigation, or stream relocation. Prior to construction, the Natural Environment Engineering Unit shall be contacted.

### **Division 3 Construction**

Pilings shall be installed by vibratory hammer or pile driver; specifically piles shall not be jetted. Should drilled shaft construction or jetting of any bridge piles become necessary, a modification to this permit will be required.

Existing bridge pilings shall be extracted or removed flush with the streambed.

### **Division 3 Construction/ Roadside Environmental**

Turbidity curtains shall be used to isolate all work areas from Bradley Creek, including pile or casement installation, placement of riprap, excavation or filling. The turbidity curtains shall be installed parallel to the banks on each side of the stream. The turbidity curtains shall extend past the construction limits and attach to the silt fences containing the work site. The turbidity curtains shall not encircle a work area or extend across Bradley Creek. The turbidity curtains are to be properly maintained and retained in the water until construction is complete and all of the work area contained by the turbidity curtains has been stabilized by vegetation or other means. The turbidity curtains shall be removed when turbidity within the curtains reaches ambient levels.

Debris resulting from demolition of the existing bridge, including deck components, shall not enter wetlands or waters of the United States, even temporarily.

### **Division 3 Construction/ Roadside Environmental/ Hydraulics Unit**

This project is in a High Quality Water Zone, and therefore must comply with the Design Standards in Sensitive Watersheds, 15A NCAC 4B .0124.

### **Roadside Environmental/ Division 3 Construction/ PDEA- Natural Environment Engineering Unit**

The wetland restoration areas will be fully contained by silt fence until all of the unsuitable fill material has been removed and the restoration areas have been restored to the approximate natural elevation of the adjacent wetlands and stabilized with appropriate coastal wetland vegetation.

The permittee will ensure the removal of all unsuitable fill material within the wetland restoration areas, and will fill any void with suitable wetland substrate to the same approximate elevation as the adjacent natural wetlands or to an appropriate reference wetland elevation.

The restored causeway shall be graded to correspond to adjacent marsh elevations.

Prior to causeway excavation, the permittee shall schedule an on-site meeting with DCM to determine reference elevations for the restoration area.

**PDEA- Natural Environment Engineering Unit/ Roadside Environmental Unit**

The permittee will provide verification to DCM that the wetland restoration areas have been restored to the approximate natural elevation of the adjacent coastal wetlands.

Although annual monitoring reports and hydrologic monitoring of the restoration sites will not be required, three years after project completion, the permittee shall schedule an agency field meeting with DCM, the NC Division of Water Quality and the NC Wildlife Resources Commission, and the U.S. Army Corps of Engineers to determine if the wetland restoration areas have re-attained jurisdictional wetland status.

**Division 3 Construction/ Right of Way Utilities**

Any relocation of utility lines that is not already depicted on the attached work plan drawings, or described within the attached permit application, will require approval by DCM, either under the authority of this permit, or by the utility company obtaining separate authorization.

**Division 3 Construction/ Hydraulics Unit/ PDEA- Project Management Unit**

If the permittee determines that additional permanent and/or temporary impacts will occur that are not shown on the attached permit drawings, additional authorization from DCM will be required.



Permit Class  
**NEW**

Permit Number  
**133-04**

STATE OF NORTH CAROLINA  
Department of Environment and Natural Resources  
and  
Coastal Resources Commission

# Permit

for

Major Development in an Area of Environmental Concern  
pursuant to NCGS 113A-118

Excavation and/or filling pursuant to NCGS 113-229

Issued to **N.C. Department of Transportation, 1548 Mail Service Center, Raleigh, NC 27699-1548**

Authorizing development in New Hanover County at SR 1411 over Bradley Creek, Bridge No.10  
(TIP No. B-3496) as requested in the permittee's application dated 5/20/04

including the attached workplan drawings; two 1/2-size drawings dated revised 4/30/04 and one dated 10/16/01.

This permit, issued on 9/3/04, is subject to compliance with the application (where consistent with the permit), all applicable regulations, special conditions and notes set forth below. Any violation of these terms may be subject to fines, imprisonment or civil action; or may cause the permit to be null and void.

### **B-3496, Bridge Replacement**

- 1) In accordance with project commitments made within the Categorical Exclusion document dated July 2002, no in-water work shall be conducted from February 15th to June 30th of any year without prior approval of the NC Division of Coastal Management (DCM), in consultation with the NC Wildlife Resources Commission (WRC) and the NC Division of Marine Fisheries (DMF).
- 2) In accordance with project commitments made within the Categorical Exclusion document dated July 2002, "Guidelines for Avoiding Impacts to the West Indian Manatee, Precautionary Measures for Construction Activities in North Carolina Waters" will be used to ensure the project will not adversely affect the endangered West Indian Manatee. The most recent version of these guidelines, dated 6/2003, shall be followed.

**(See attached sheets for Additional Conditions)**

This permit action may be appealed by the permittee or other qualified persons within twenty (20) days of the issuing date. An appeal requires resolution prior to work initiation or continuance as the case may be.

This permit must be accessible on-site to Department personnel when the project is inspected for compliance.

Any maintenance work or project modification not covered hereunder requires further Division approval.

All work must cease when the permit expires on

### **No Expiration Date, pursuant to GS 136-44.7B**

In issuing this permit, the State of North Carolina agrees that your project is consistent with the North Carolina Coastal Management Program.

Signed by the authority of the Secretary of DENR and the Chairman of the Coastal Resources Commission.



*for* Charles S. Jones, Director  
Division of Coastal Management

This permit and its conditions are hereby accepted.

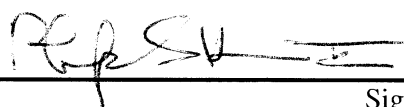

Signature of Permittee

**ADDITIONAL CONDITIONS**

- 3) The permittee shall implement NC DOT's Stream Crossing Guidelines for Anadromous Fish Passage, except as modified in Condition No. 1 of this permit.
- 4) Pilings shall be installed by vibratory hammer or pile driver; specifically piles shall not be jetted. Should drilled shaft construction or jetting of any bridge piles become necessary, a modification to this permit will be required.
- 5) The NCDOT document "Best Management Practices for Bridge Demolition and Removal" (final 9/20/99) shall be followed during demolition and construction activities.
- 6) Existing bridge pilings shall be extracted or removed flush with the streambed.
- 7) Turbidity curtains shall be used to isolate all work areas from Bradley Creek, including pile or casement installation, placement of riprap, excavation or filling. The turbidity curtains shall be installed parallel to the banks on each side of the stream. The turbidity curtains shall extend past the construction limits and attach to the silt fences containing the work site. The turbidity curtains shall not encircle a work area or extend across Bradley Creek. The turbidity curtains are to be properly maintained and retained in the water until construction is complete and all of the work area contained by the turbidity curtains has been stabilized by vegetation or other means. The turbidity curtains shall be removed when turbidity within the curtains reaches ambient levels.
- 8) All excavated materials and debris associated with the removal of the existing bridge and existing causeway will be disposed of on an approved upland site.
- 9) The temporary placement or double handling of excavated or fill materials within waters or vegetated wetlands are not authorized.
- 10) All excavated materials will be confined above normal high water and landward of regularly or irregularly flooded wetlands behind adequate dikes or other retaining structures to prevent spillover of solids into any wetlands or surrounding waters.
- 11) Debris resulting from demolition of the existing bridge, including deck components, shall not enter wetlands or waters of the United States, even temporarily.
- 12) No excavated or fill material will be placed at any time in any vegetated wetlands or surrounding waters outside of the alignment of the fill area indicated on the work plan drawing(s).
- 13) The fill material will be clean and free of any pollutants except in trace quantities.
- 14) There shall be no clearing or grubbing of wetlands outside of the area indicated on the workplan drawings.
- 15) No excavation will take place at any time in any vegetated wetlands or surrounding waters outside of the alignment of the fill areas indicated on the workplan drawing(s).

**ADDITIONAL CONDITIONS**

- 16) Placement of riprap shall be limited to the areas as depicted on the attached work plan drawings. The riprap material must be free from loose dirt or any pollutant. It must be of a size sufficient to prevent its movement from the site by wave or current action. The riprap material must consist of clean rock or masonry materials, such as but not limited to, granite or broken concrete.
- 17) Live concrete shall not be allowed to contact waters of the state or water that will enter waters of the state.

**Sedimentation and Erosion Control**

- 18) The permittee shall follow Best Management Practices for the Protection of Surface Waters and sedimentation and erosion control measures sufficient to protect aquatic resources.
- 19) This project is in a High Quality Water Zone, and therefore must comply with the Design Standards in Sensitive Watersheds, 15A NCAC 4B .0124.
- 20) Appropriate sedimentation and erosion control devices, measures or structures must be implemented to ensure that eroded materials do not enter adjacent wetlands, watercourses and property (e.g. silt fence, diversion swales or berms, etc.).
- 21) This project must conform to all requirements of the NC Sedimentation Pollution Control Act and NC DOT's Memorandum of Agreement with the Division of Land Resources.

**Mitigation**

**NOTE:** Mitigation for approximately 0.04 acres of permanent coastal wetland impacts on this project will be provided through on-site wetland restoration from the removal of approximately 160 linear feet of existing causeway fill material.

- 22) The wetland restoration areas will be fully contained by silt fence until all of the unsuitable fill material has been removed and the restoration areas have been restored to the approximate natural elevation of the adjacent wetlands and stabilized with appropriate coastal wetland vegetation.
- 23) The permittee will ensure the removal of all unsuitable fill material within the wetland restoration areas, and will fill any void with suitable wetland substrate to the same approximate elevation as the adjacent natural wetlands or to an appropriate reference wetland elevation.
- 24) The restored causeway shall be graded to correspond to adjacent marsh elevations.
- 25) Prior to causeway excavation, the permittee shall schedule an on-site meeting with DCM to determine reference elevations for the restoration area.
- 26) The permittee will provide verification to DCM that the wetland restoration areas have been restored to the approximate natural elevation of the adjacent coastal wetlands.

**ADDITIONAL CONDITIONS**

- 27) Although annual monitoring reports and hydrologic monitoring of the restoration sites will not be required, three years after project completion, the permittee shall schedule an agency field meeting with DCM, the NC Division of Water Quality and the NC Wildlife Resources Commission, and the U.S. Army Corps of Engineers to determine if the wetland restoration areas have re-attained jurisdictional wetland status.

**NOTE:** The exact amount of wetland restoration and enhancement credits will not be determined until the mitigation site receives confirmation from DCM, DWQ, and USACE that the site has re-attained jurisdictional status. DCM will require that the amount of coastal wetlands impacted by the project be deducted from any restoration or enhancement credits generated from the project.

**NOTE:** This permit does not convey or imply approval of the suitability of the excess mitigation generated by this project as compensatory wetland mitigation for any particular future projects. The use of any portion of the excess mitigation generated by this project as compensatory mitigation for future projects will be approved on a case-by-case basis during the CAMA permit review and/or consistency process.

**NOTE:** If the excess mitigation generated by this project is to be used as mitigation for impacts of future projects, written concurrence must be obtained from DCM that post-construction monitoring demonstrates that vegetative and hydrologic success criteria have been met.

**General**

- 28) Any relocation of utility lines that is not already depicted on the attached work plan drawings, or described within the attached permit application, will require approval by DCM, either under the authority of this permit, or by the utility company obtaining separate authorization.
- 29) If the permittee determines that additional permanent and/or temporary impacts will occur that are not shown on the attached permit drawings, additional authorization from DCM will be required.
- 30) This permit does not eliminate the need to obtain any additional permits, approvals or authorizations that may be required.
- 31) The N.C. Division of Water Quality (DWQ) has authorized the proposed project under a General Water Quality Certification (DWQ Project No. 04-0421), which was issued on 3/18/04. Any violation of the Certification approved by the DWQ will be considered a violation of this CAMA permit.
- 32) The NC Division of Water Quality (DWQ) reviewed the proposed activity of this project for the applicability of the Stormwater Management rules and determined that the development activity, as proposed at this site, is not subject to the stormwater requirements as provided for in 15A NCAC 2H .1000. If at any time in the future, development of any part of this site is planned or if proposed activities differ in any manner from what is shown on the plans on file with DWQ, the permittee must submit the project to DWQ and DCM for review and additional authorization from DCM may be required.

**ADDITIONAL CONDITIONS**

**NOTE:**

The U.S. Army Corps of Engineers authorized the proposed project under Nationwide Permit Number 23 (COE Action ID No. 199802171), which was issued on 7/1/04.



North Carolina Department of Environment and Natural Resources  
**Division of Coastal Management**

Michael F. Easley, Governor

**Charles S. Jones, Director**

William G. Ross Jr., Secretary

September 3, 2004

NC Department of Transportation  
1548 Mail Service Center  
Raleigh, NC 27699

Dear Sirs:

The enclosed permit constitutes authorization under the Coastal Area Management Act, and where applicable, the State Dredge and Fill Law, for you to proceed with your project proposal. The original (buff-colored form) is retained by you and it must be available on site when the project is inspected for compliance. Please sign both the original and the copy and return the copy to this office in the enclosed envelope. Signing the permit and proceeding means you have waived your right of appeal described below.

If you object to the permit or any of the conditions, you may request a hearing pursuant to NCGS 113A-121.1 or 113-229. Your petition for a hearing must be filed in accordance with NCGS Chapter 150B with the Office of Administrative Hearings, 6714 Mail Service Center, Raleigh, NC 27611-6714, (919) 733-2698 within twenty (20) days of this decision on your permit. You should also be aware that if another qualified party submits a valid objection to the issuance of this permit within twenty (20) days, the matter must be resolved prior to work initiation. The Coastal Resources Commission makes the final decision on any appeal.

The project plan is subject to those conditions appearing on the permit form. Otherwise, all work must be carried out in accordance with your application. Modifications, time extensions, and future maintenance require additional approval. Please read your permit carefully prior to starting work and review all project plans, as approved. If you are having the work done by a contractor, it would be to your benefit to be sure that he fully understands all permit requirements.

From time to time, Department personnel will visit the project site. To facilitate this review, we request that you complete and mail the enclosed Notice Card just prior to work initiation. However, if questions arise concerning permit conditions, environmental safeguards, or problem areas, you may contact Department personnel at any time for assistance. By working in accordance with the permit, you will be helping to protect our vitally important coastal resources.

Sincerely,

Douglas V. Huggett  
Major Permits and Consistency Manager

Enclosure

1638 Mail Service Center, Raleigh, North Carolina 27699-1638  
Phone: 919-733-2293 \ FAX: 919-733-1495 \ Internet: <http://dcm2.enr.state.nc.us>

An Equal Opportunity \ Affirmative Action Employer – 50% Recycled \ 10% Post Consumer Paper

**STATE OF NORTH CAROLINA**  
Department of Environment and Natural Resources  
and  
Coastal Resources Commission

**Permit**

C O P Y

for

Major Development in an Area of Environmental Concern  
pursuant to NCGS 113A-118

Excavation and/or filling pursuant to NCGS 113-229

Issued to N.C. Department of Transportation, 1548 Mail Service Center, Raleigh, NC 27699-1548

Authorizing development in New Hanover County at SR 1411 over Bradley Creek, Bridge No.10  
(TIP No. B-3496) as requested in the permittee's application dated 5/20/04

including the attached workplan drawings; two 1/2-size drawings dated revised 4/30/04 and one dated 10/16/01.

This permit, issued on 9/3/04, is subject to compliance with the application (where consistent with the permit), all applicable regulations, special conditions and notes set forth below. Any violation of these terms may be subject to fines, imprisonment or civil action; or may cause the permit to be null and void.

**B-3496, Bridge Replacement**

- 1) In accordance with project commitments made within the Categorical Exclusion document dated July 2002, no in-water work shall be conducted from February 15th to June 30th of any year without prior approval of the NC Division of Coastal Management (DCM), in consultation with the NC Wildlife Resources Commission (WRC) and the NC Division of Marine Fisheries (DMF).
- 2) In accordance with project commitments made within the Categorical Exclusion document dated July 2002, "Guidelines for Avoiding Impacts to the West Indian Manatee, Precautionary Measures for Construction Activities in North Carolina Waters" will be used to ensure the project will not adversely affect the endangered West Indian Manatee. The most recent version of these guidelines, dated 6/2003, shall be followed.

**(See attached sheets for Additional Conditions)**

This permit action may be appealed by the permittee or other qualified persons within twenty (20) days of the issuing date. An appeal requires resolution prior to work initiation or continuance as the case may be.

This permit must be accessible on-site to Department personnel when the project is inspected for compliance.

Any maintenance work or project modification not covered hereunder requires further Division approval.

All work must cease when the permit expires on

**No Expiration Date, pursuant to GS 136-44.7B**

In issuing this permit, the State of North Carolina agrees that your project is consistent with the North Carolina Coastal Management Program.

Signed by the authority of the Secretary of DENR and the Chairman of the Coastal Resources Commission.

*Charles S. Jones*

for Charles S. Jones, Director  
Division of Coastal Management

This permit and its conditions are hereby accepted.

*PERMITTEE*

Signature of Permittee

**ADDITIONAL CONDITIONS**

- 3) The permittee shall implement NC DOT's Stream Crossing Guidelines for Anadromous Fish Passage, except as modified in Condition No. 1 of this permit.
- 4) Pilings shall be installed by vibratory hammer or pile driver; specifically piles shall not be jetted. Should drilled shaft construction or jetting of any bridge piles become necessary, a modification to this permit will be required.
- 5) The NCDOT document "Best Management Practices for Bridge Demolition and Removal" (final 9/20/99) shall be followed during demolition and construction activities.
- 6) Existing bridge pilings shall be extracted or removed flush with the streambed.
- 7) Turbidity curtains shall be used to isolate all work areas from Bradley Creek, including pile or casement installation, placement of riprap, excavation or filling. The turbidity curtains shall be installed parallel to the banks on each side of the stream. The turbidity curtains shall extend past the construction limits and attach to the silt fences containing the work site. The turbidity curtains shall not encircle a work area or extend across Bradley Creek. The turbidity curtains are to be properly maintained and retained in the water until construction is complete and all of the work area contained by the turbidity curtains has been stabilized by vegetation or other means. The turbidity curtains shall be removed when turbidity within the curtains reaches ambient levels.
- 8) All excavated materials and debris associated with the removal of the existing bridge and existing causeway will be disposed of on an approved upland site.
- 9) The temporary placement or double handling of excavated or fill materials within waters or vegetated wetlands are not authorized.
- 10) All excavated materials will be confined above normal high water and landward of regularly or irregularly flooded wetlands behind adequate dikes or other retaining structures to prevent spillover of solids into any wetlands or surrounding waters.
- 11) Debris resulting from demolition of the existing bridge, including deck components, shall not enter wetlands or waters of the United States, even temporarily.
- 12) No excavated or fill material will be placed at any time in any vegetated wetlands or surrounding waters outside of the alignment of the fill area indicated on the work plan drawing(s).
- 13) The fill material will be clean and free of any pollutants except in trace quantities.
- 14) There shall be no clearing or grubbing of wetlands outside of the area indicated on the workplan drawings.
- 15) No excavation will take place at any time in any vegetated wetlands or surrounding waters outside of the alignment of the fill areas indicated on the workplan drawing(s).



**ADDITIONAL CONDITIONS**

- 16) Placement of riprap shall be limited to the areas as depicted on the attached work plan drawings. The riprap material must be free from loose dirt or any pollutant. It must be of a size sufficient to prevent its movement from the site by wave or current action. The riprap material must consist of clean rock or masonry materials, such as but not limited to, granite or broken concrete.
- 17) Live concrete shall not be allowed to contact waters of the state or water that will enter waters of the state.

**Sedimentation and Erosion Control**

- 18) The permittee shall follow Best Management Practices for the Protection of Surface Waters and sedimentation and erosion control measures sufficient to protect aquatic resources.
- 19) This project is in a High Quality Water Zone, and therefore must comply with the Design Standards in Sensitive Watersheds, 15A NCAC 4B .0124.
- 20) Appropriate sedimentation and erosion control devices, measures or structures must be implemented to ensure that eroded materials do not enter adjacent wetlands, watercourses and property (e.g. silt fence, diversion swales or berms, etc.).
- 21) This project must conform to all requirements of the NC Sedimentation Pollution Control Act and NC DOT's Memorandum of Agreement with the Division of Land Resources.

**Mitigation**

**NOTE:** Mitigation for approximately 0.04 acres of permanent coastal wetland impacts on this project will be provided through on-site wetland restoration from the removal of approximately 160 linear feet of existing causeway fill material.

- 22) The wetland restoration areas will be fully contained by silt fence until all of the unsuitable fill material has been removed and the restoration areas have been restored to the approximate natural elevation of the adjacent wetlands and stabilized with appropriate coastal wetland vegetation.
- 23) The permittee will ensure the removal of all unsuitable fill material within the wetland restoration areas, and will fill any void with suitable wetland substrate to the same approximate elevation as the adjacent natural wetlands or to an appropriate reference wetland elevation.
- 24) The restored causeway shall be graded to correspond to adjacent marsh elevations.
- 25) Prior to causeway excavation, the permittee shall schedule an on-site meeting with DCM to determine reference elevations for the restoration area.
- 26) The permittee will provide verification to DCM that the wetland restoration areas have been restored to the approximate natural elevation of the adjacent coastal wetlands.

**ADDITIONAL CONDITIONS**

- 27) Although annual monitoring reports and hydrologic monitoring of the restoration sites will not be required, three years after project completion, the permittee shall schedule an agency field meeting with DCM, the NC Division of Water Quality and the NC Wildlife Resources Commission, and the U.S. Army Corps of Engineers to determine if the wetland restoration areas have re-attained jurisdictional wetland status.

**NOTE:** The exact amount of wetland restoration and enhancement credits will not be determined until the mitigation site receives confirmation from DCM, DWQ, and USACE that the site has re-attained jurisdictional status. DCM will require that the amount of coastal wetlands impacted by the project be deducted from any restoration or enhancement credits generated from the project.

**NOTE:** This permit does not convey or imply approval of the suitability of the excess mitigation generated by this project as compensatory wetland mitigation for any particular future projects. The use of any portion of the excess mitigation generated by this project as compensatory mitigation for future projects will be approved on a case-by-case basis during the CAMA permit review and/or consistency process.

**NOTE:** If the excess mitigation generated by this project is to be used as mitigation for impacts of future projects, written concurrence must be obtained from DCM that post-construction monitoring demonstrates that vegetative and hydrologic success criteria have been met.

**General**

- 28) Any relocation of utility lines that is not already depicted on the attached work plan drawings, or described within the attached permit application, will require approval by DCM, either under the authority of this permit, or by the utility company obtaining separate authorization.
- 29) If the permittee determines that additional permanent and/or temporary impacts will occur that are not shown on the attached permit drawings, additional authorization from DCM will be required.
- 30) This permit does not eliminate the need to obtain any additional permits, approvals or authorizations that may be required.
- 31) The N.C. Division of Water Quality (DWQ) has authorized the proposed project under a General Water Quality Certification (DWQ Project No. 04-0421), which was issued on 3/18/04. Any violation of the Certification approved by the DWQ will be considered a violation of this CAMA permit.
- 32) The NC Division of Water Quality (DWQ) reviewed the proposed activity of this project for the applicability of the Stormwater Management rules and determined that the development activity, as proposed at this site, is not subject to the stormwater requirements as provided for in 15A NCAC 2H .1000. If at any time in the future, development of any part of this site is planned or if proposed activities differ in any manner from what is shown on the plans on file with DWQ, the permittee must submit the project to DWQ and DCM for review and additional authorization from DCM may be required.

**ADDITIONAL CONDITIONS**

**NOTE:**

The U.S. Army Corps of Engineers authorized the proposed project under Nationwide Permit Number 23 (COE Action ID No. 199802171), which was issued on 7/1/04.

REVISIONS

-L-  
 PI Sta 14+33.13  
 $\Delta = 15' 33" 58.6'$  (RT)  
 $D = 5' 00" 00.0'$   
 $L = 311.33'$   
 $T = 156.63'$   
 $R = 1145.92'$   
 SE = SEE PLANS

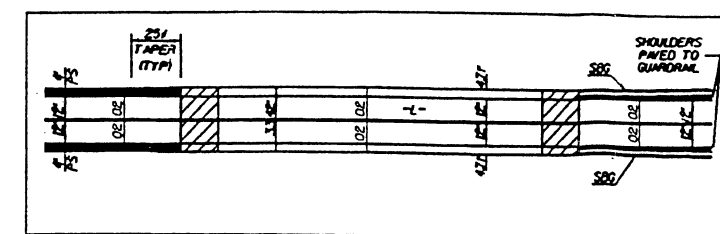

RELATIONSHIP OF PAVEMENT TO BRIDGE

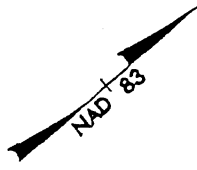

PROJECT REFERENCE NO. B-3496	SHEET 4
RAW SHEET NO.	
ROADWAY DESIGN ENGINEER	HYDRAULICS ENGINEER

NCDOT  
 DIVISION OF HIGHWAYS  
 NEW HANOVER COUNTY  
 PROJECT 4326111 (B-3496)  
 REPLACE BRIDGE N. 18 ON SR 11-0  
 OVER BRADLEY CREEK  
 4077  
 Revised 1/24/2004

STA. 14+00.00 -L-  
 BEGIN TIP PROJECT B-3496

STA. 22+00.00 -L- END TIP PROJECT B-3496

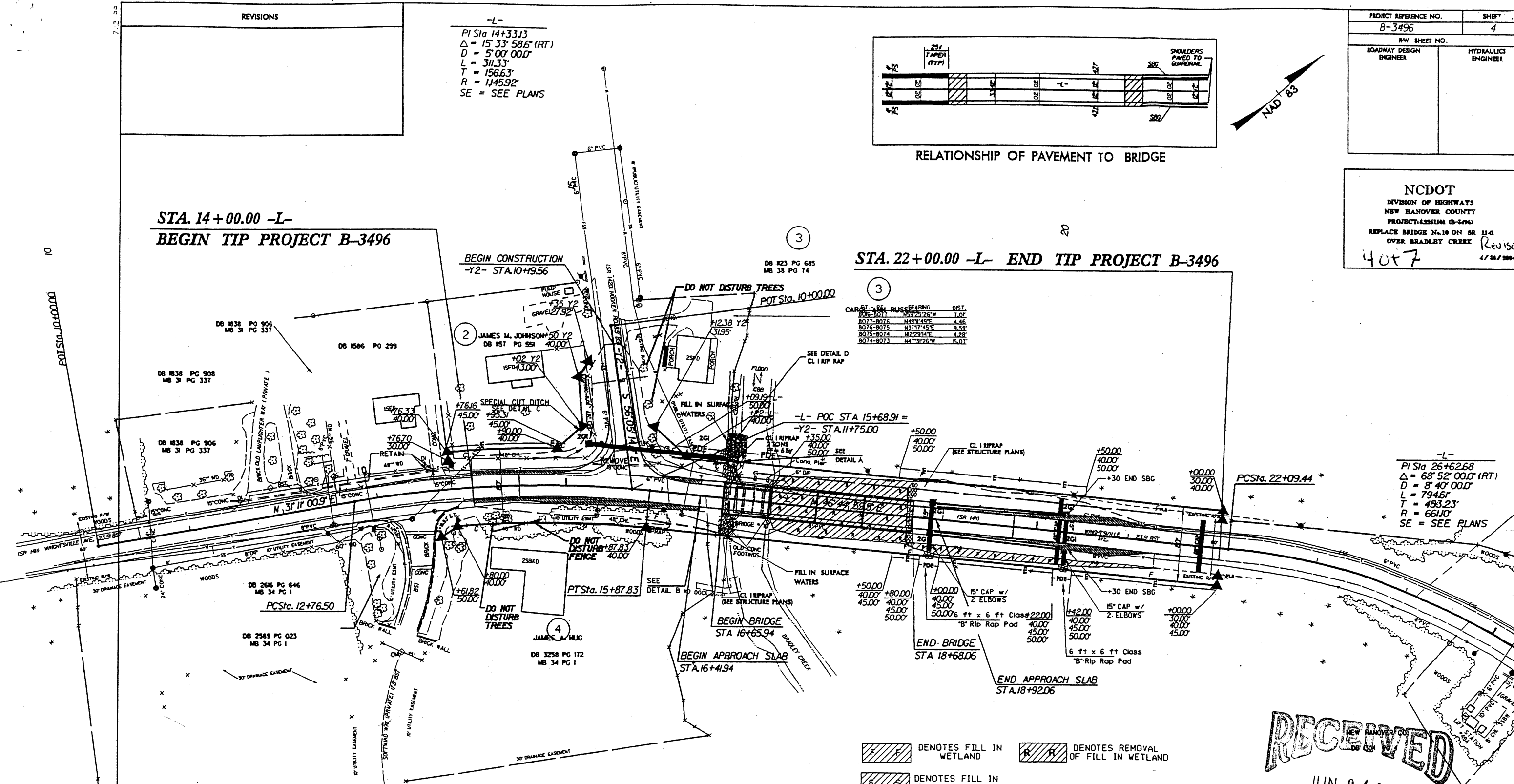

CARPET - RL - RUS - BEARING	DIST.
8006-8011	12172.26' W
8011-8016	14311.45' E
8016-8075	13117.45' E
8075-8074	11279.14' E
8074-8073	14131.26' W

-L-  
 PI Sta 26+62.68  
 $\Delta = 68' 52" 00.0'$  (RT)  
 $D = 8' 40" 00.0'$   
 $L = 794.6'$   
 $T = 493.23'$   
 $R = 661.0'$   
 SE = SEE PLANS

**DATUM DESCRIPTION**  
 THE LOCALIZED COORDINATE SYSTEM DEVELOPED FOR THIS PROJECT IS BASED ON THE STATE PLANE COORDINATES ESTABLISHED BY NCDOT FOR MONUMENT "B3496-2" WITH NAD 83 STATE PLANE GRID COORDINATES OF NORTHING: 113811.00(11) EASTING: 2348781.14(11) THE AVERAGE COMBINED GRID FACTOR USED ON THIS PROJECT (GROUND TO GRID) IS: 1.000038649 THE N.C. LAMBERT GRID BEARING LOCALIZED HORIZONTAL GROUND DISTANCE FROM "B3496-2" TO 4+ STATION 14+00.00 IS 5 42' 07" 2426 E DISTANCE 640.1185 FT. ALL LINEAR DIMENSIONS ARE LOCALIZED HORIZONTAL DISTANCES VERTICAL DATUM USED IS MVD 29

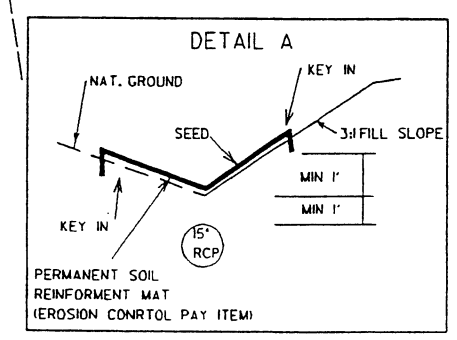

STATION 16+50 TO 16+70 -L- Lt

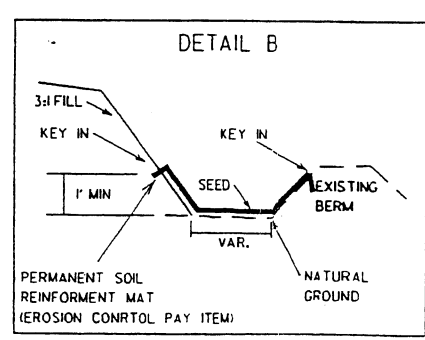

STATION 16+00 TO 16+50 -L- Rt

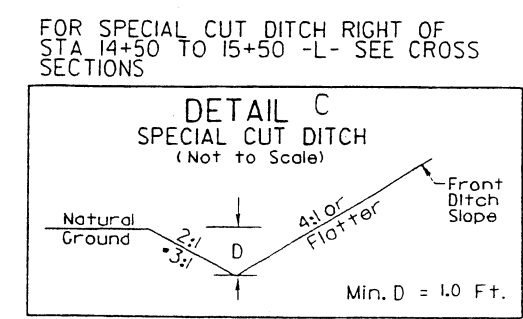

• STA 14+50 TO 15+25 -L- Lt

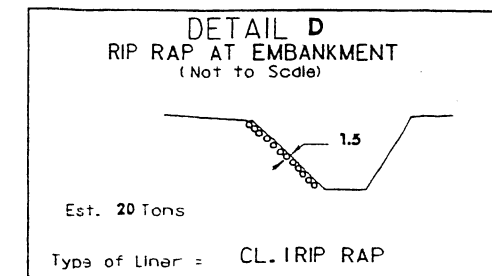

- DENOTES FILL IN WETLAND
- DENOTES REMOVAL OF FILL IN WETLAND
- DENOTES FILL IN SURFACE WATER

**RECEIVED**  
 JUN 04 2004

Morehead City DCM

DANIEL K. ALDE  
 DB M49 PG 72

REVISIONS

-L-  
PI Sta 14+33.13  
Δ = 15° 33' 58.6" (RT)  
D = 5' 00' 0.00"  
L = 311.33'  
T = 156.63'  
R = 1145.92'  
SE = SEE PLANS

PROJECT REFERENCE NO.	SHEET
B-3496	4
RW SHEET NO.	
ROADWAY DESIGN ENGINEER	HYDRAULICS ENGINEER

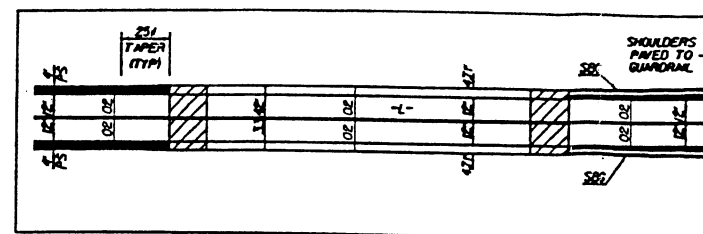

RELATIONSHIP OF PAVEMENT TO BRIDGE

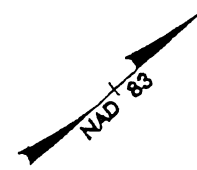

STA. 14+00.00 -L-  
BEGIN TIP PROJECT B-3496

STA. 22+00.00 -L- END TIP PROJECT B-3496

NCDOT  
DIVISION OF HIGHWAYS  
NEW HANOVER COUNTY  
PROJECT: A251101 G-3496  
REPLACE BRIDGE N. 19 ON SR 114  
OVER BRADLEY CREEK  
5 of 7  
Revised 4/28/2004

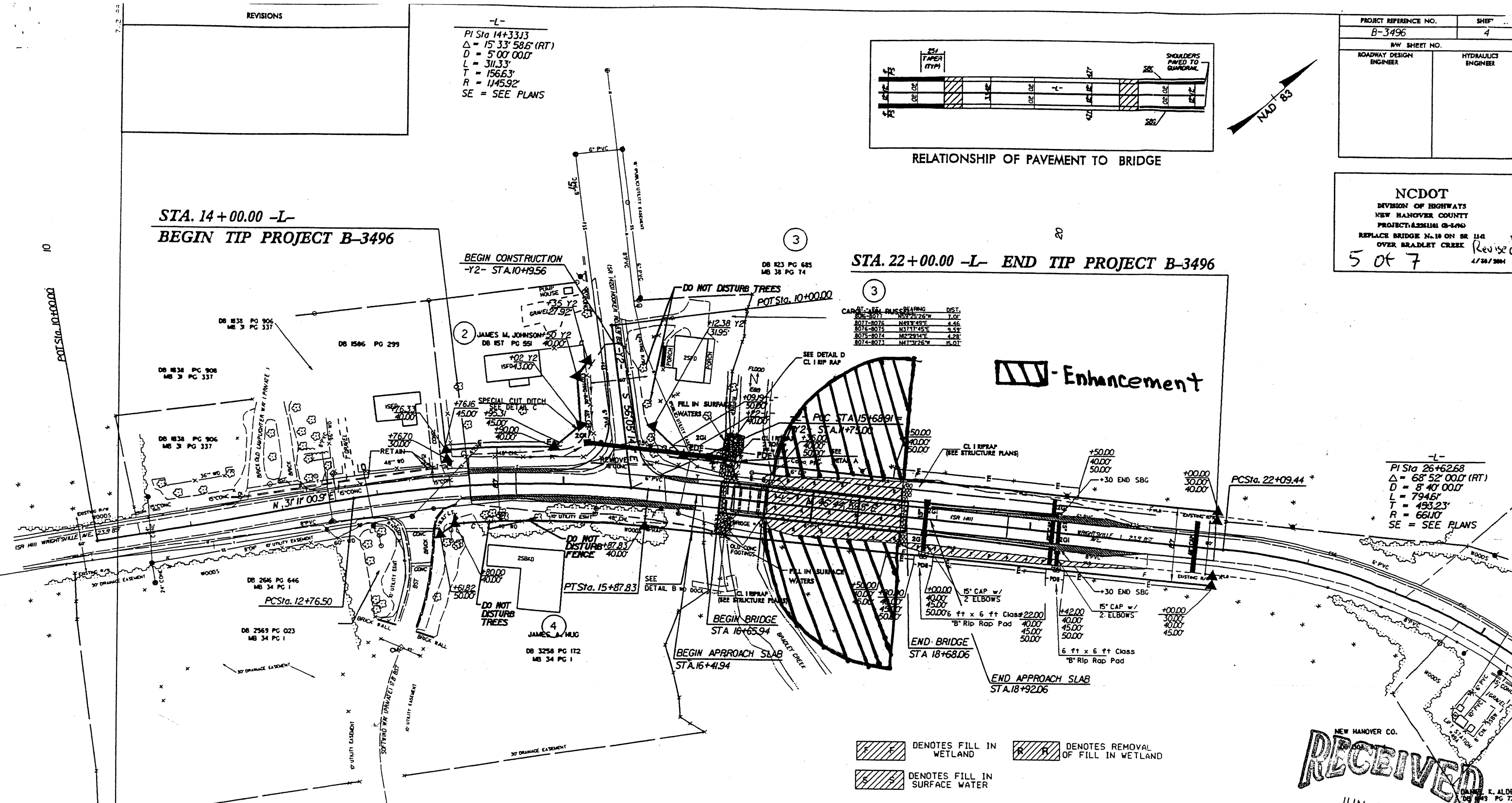

CAR	AXL	RIP	BEARING	DIST.
807-8071	85	25	26"	7.0'
8071-8076	145	14	45"	4.45'
8076-8079	131	17	45"	5.53'
8079-8074	182	23	14"	4.28'
8074-8071	141	26"		15.0'

Enhancement

-L-  
PI Sta 26+62.68  
Δ = 68° 52' 00.0" (RT)  
D = 8' 40' 0.00"  
L = 794.61'  
T = 493.23'  
R = 661.0'  
SE = SEE PLANS

- DENOTES FILL IN WETLAND
- DENOTES REMOVAL OF FILL IN WETLAND
- DENOTES FILL IN SURFACE WATER

**DATUM DESCRIPTION**  
THE LOCALIZED COORDINATE SYSTEM DEVELOPED FOR THIS PROJECT IS BASED ON THE STATE PLANE COORDINATES ESTABLISHED BY NCDOT FOR MONUMENT "B3496-2" WITH NAD 83 STATE PLANE GRID COORDINATES OF NORTHING: 173841.808(11) EASTING: 2348281.146(11) THE AVERAGE COMBINED GRID FACTOR USED ON THIS PROJECT GROUND TO GRID IS: 1.000038649 THE N.C. LAMBERT GRID BEARING LOCALIZED HORIZONTAL GROUND DISTANCE FROM "B3496-2" TO + STATION 14+00.00 IS 5' 42" 07 24.26 E DISTANCE 640.1185 FT. ALL LINEAR DIMENSIONS ARE LOCALIZED HORIZONTAL DISTANCES VERTICAL DATUM USED IS MVD 29

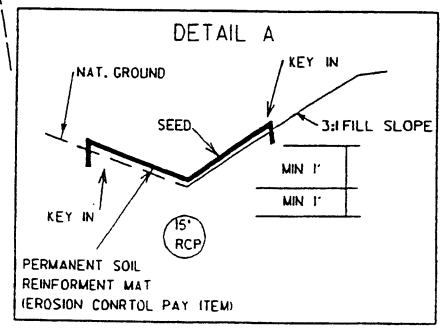

STATION 16+50 TO 16+70 -L- Lt

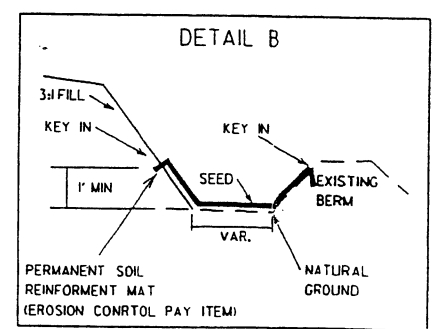

STATION 16+00 TO 16+50 -L- Rt

FOR SPECIAL CUT DITCH RIGHT OF STA 14+50 TO 15+50 -L- SEE CROSS SECTIONS

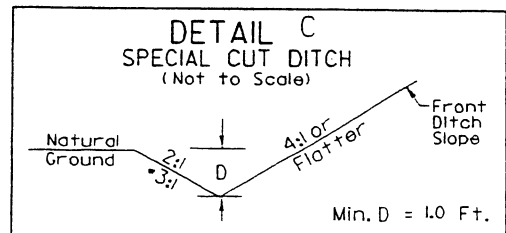

• STA 14+50 TO 15+25 -L- Lt  
• STA 10+50 TO 11+75 -L- Rt

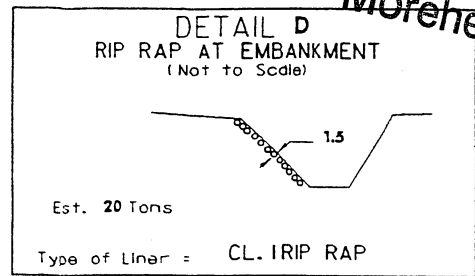

FOR -L- & -Y2- BRIDGE SEE SHEET E

NEW HANOVER CO.  
**RECEIVED**  
JUN 04 2004  
Morehead City DCM



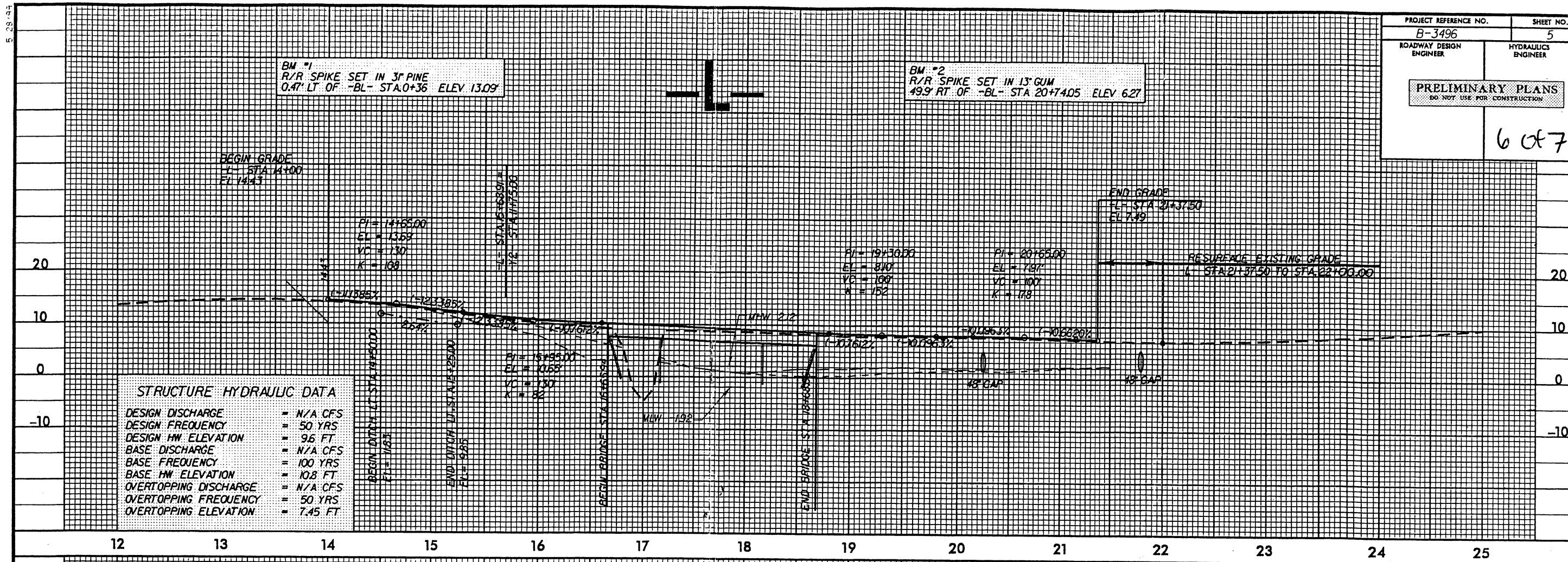

STRUCTURE HYDRAULIC DATA	
DESIGN DISCHARGE	= N/A CFS
DESIGN FREQUENCY	= 50 YRS
DESIGN HW ELEVATION	= 9.6 FT
BASE DISCHARGE	= N/A CFS
BASE FREQUENCY	= 100 YRS
BASE HW ELEVATION	= 10.8 FT
OVERTOPPING DISCHARGE	= N/A CFS
OVERTOPPING FREQUENCY	= 50 YRS
OVERTOPPING ELEVATION	= 7.45 FT

-Y2-

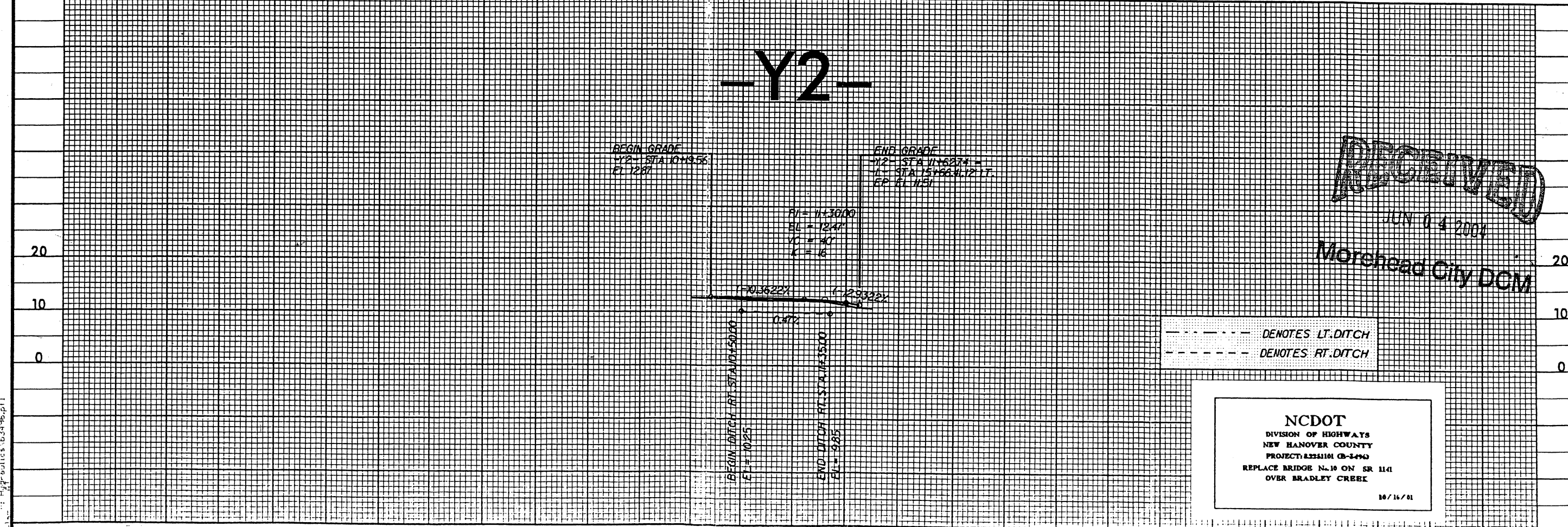

RECEIVED

JUN 04 2004

Morehead City DCM

----- DENOTES LT. DITCH  
 - - - - - DENOTES RT. DITCH

**NCDOT**  
 DIVISION OF HIGHWAYS  
 NEW HANOVER COUNTY  
 PROJECT: 8221101 (B-3496)  
 REPLACE BRIDGE N.10 ON SR 1141  
 OVER BRADLEY CREEK  
 10/16/01

I:\Projects\8221101\8221101.dwg  
 10/16/01

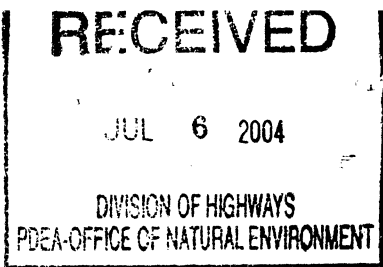

Henry T. ...



U.S. ARMY CORPS OF ENGINEERS  
Wilmington District  
P.O.Box 1890  
Wilmington, NC 28402-1890

Action ID: 199802171 TIP No. B-3496 State Project No. 8.2251101

County: Ne

**GENERAL PERMIT (REGIONAL AND NATIONWIDE) VERIFICATION**

**Property Owner:** Gregory J. Thorpe, Ph.D.  
**Address:** Environmental Management Director, PDEA  
N.C. Department of Transportation  
1548 Mail Service Center  
Raleigh, NC 27699-1548  
**Telephone Number:** (910) 733-3141

**Size and Location of project (waterway, road name/number, town, etc.):** Bridge No. 10 on SR 1411 (Oleander Drive) over Bradley Creek, New Hanover County, North Carolina.

**Description of Activity:** Discharge of fill material permanently impacting a total of 0.04 acres of waters of the United States, including wetlands and 48 feet of perennial stream, for construction of TIP Project No. B-3496 for replacement of Bridge No. 10 on SR 1411 (Oleander Drive) over Bradley Creek, New Hanover County, North Carolina, as described in NCDOT letter dated May 21, 2004 and Categorical Exclusion document dated 1 July 2002. Bridge No. 10 is 39 ft long and 29.3 ft wide (28 ft clear roadway with two 11 foot travel lanes) and has a reinforced concrete deck supported by timber caps and timber piles with timber bulkhead-type abutments. Bridge No. 10 will be replaced, using top down construction methods, in its existing location and elevation with a new bridge that will be approximately 200 ft long and clear roadway width of 33 feet with two 12-foot travel lanes with 4.5 foot wide offsets for pedestrian and bicycle passage. Approximately 160 feet of the existing fill causeway will be removed, areas graded to match adjacent marsh areas, and stabilized with vegetation endemic to the area. During construction SR 1411 traffic will be detoured along existing area roads. Work associated with the proposed project, including sewer line utilities, shall be accomplished in accordance with the attached special conditions.

**Applicable Law:**  Section 404 (Clean Water Act, 33 U.S.C. 1344)  
 Section 10 (River and Harbor Act of 1899)  
**Authorization:** 23 Nationwide Permit Number  
 Regional General Permit Number

Your work is authorized by this Regional General (RGP) or Nationwide (NWP) Permit provided it is accomplished in strict accordance with the attached conditions and your submitted plans. If your activity is subject to Section 404 (if Section 404 block above is checked), before beginning work you must also receive a Section 401 water quality certification from the N.C. Division of Environmental Management, telephone (919) 733-1786. For any activity within the twenty coastal counties, before beginning work you must contact the N.C. Division of Coastal Management, telephone (919) 733-2293.

Please read and carefully comply with the attached conditions of the RGP or NWP. Any violation of the conditions of the RGP or NWP referenced above may subject the permittee to a stop work order, a restoration order, and/or appropriate legal action.

This Department of the Army RGP or NWP verification does not relieve the permittee of the responsibility to obtain any other required Federal, State, or local approvals/permits. The permittee may need to contact appropriate State and local agencies before beginning work.

This verification will remain valid until 1 July 2006 unless the nationwide authorization is modified, reissued or revoked. If, prior to 1 July 2006 the nationwide permit authorization is reissued and/or modified, this verification will remain valid until 1 July 2006, provided it complies with all modifications. If the nationwide permit authorization expires or is suspended, revoked, or is modified, such that the activity would no longer comply with the terms and

**GENERAL PERMIT (REGIONAL AND NATIONWIDE) VERIFICATION**

conditions of the nationwide permit, activities which have commenced (i.e., are under construction) or are under contract to commence in reliance upon the nationwide permit, will remain authorized provided the activity is completed within twelve months of the date of the nationwide permit's expiration, modification or revocation, unless discretionary authority has been exercised on a case-by-case basis to modify, suspend or revoke the authorization.

If there are any questions regarding this authorization or any of the conditions of this NWP, please contact Mr. Dave Timpy of the Corps Regulatory Office in Wilmington at the phone number specified below.

Date July 1, 2004

Corps Regulatory Official

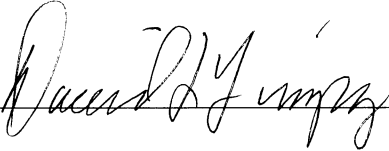

Telephone No. (910) 251-4634

CF: NCDOT- Mr. Mason Herndon, Division Environmental Officer, NCDOT Division 3.



**SPECIAL CONDITIONS**

**TIP Project No. B-3496**

**Action ID 199802171**

**July 1, 2004**

1. Bridge demolition and removal will be accomplished in accordance with "North Carolina Department of Transportation Policy: Bridge Demolition and Removal in Waters of the United States" dated September 20, 1999 and the NCDOT permit application for this project submitted by letter dated May 21, 2004. No fill will be placed in Bradley Creek during removal of the existing bridge and utility structures.
2. Following completion of the TIP project B-3496, the causeway area must be graded to an elevation similar to the adjacent wetland and re-planted with native wetland vegetation. As built elevations of the causeway shall be submitted to the Corps of Engineers for approval prior to planting of the site.
3. Sewer line utilities will be relocated using a directional bore drilling method. Entry and exit points of this activity, including disposal of material from the drilling activity, will be outside of the jurisdictional wetland areas.
4. Turbidity curtains shall be installed to reduce turbidity in accordance with "North Carolina Department of Transportation, Best Management Practices for Construction and Maintenance Activities" dated August 2003.
5. A moratorium on all work in the waters Bradley Creek and its tributaries will be in effect from February 15 to June 30 of any year.
6. All work must be performed as shown on the attached plans, which are a part of this permit. Failure to institute and carry out the details of the following special conditions, below, will result in a directive to cease all ongoing and permitted work within waters and/or wetlands associated with the permitted project, or such other remedies and/or fines as the District Engineer or his authorized representatives may seek.
7. The temporary placement or double handling of excavated or fill material or construction equipment and materials within waters and wetlands are not authorized.
8. One copy of the final construction drawings shall be furnished to the District Engineer prior to the pre-construction meeting. Written verification shall be provided that the final construction drawings comply with the attached permit drawings. The permittee shall ensure that the construction design plans for this project do not deviate from the permit plans attached to this authorization. Any deviation in the construction design plans, including bridge demolition, shall be brought to the attention of the Corps of Engineers, Mr. Dave Timpy, Wilmington Regulatory Field Office prior to any active construction in waters or wetlands.

9. The permittee shall schedule a preconstruction meeting between its representatives, the contractor's representatives, and the Corps of Engineers, Wilmington Regulatory Field Office NCDOT Regulatory Project Manager, prior to any work within jurisdictional waters and wetlands to ensure that there is a mutual understanding of all of the terms and conditions contained within this Department of the Army Permit. The permittee shall notify the Corps of Engineers Project Manager a minimum of thirty (30) days in advance of the scheduled meeting in order to provide that individual with ample opportunity to schedule and participate in the required meeting.
10. The permittee shall require its contractors and/or agents to comply with the terms and conditions of this permit in the construction and maintenance of this project, and shall provide each of its contractors and/or agents associated with the construction or maintenance of this project with a copy of this permit. Copies of this permit and any modifications authorized by the USACE shall be available for review at the construction site at all times. All violations, including non-compliance of these conditions, of the authorized permit shall be reported to the District Engineer within 24 hours of the violation.
11. The permittee shall remove all sediment and erosion control measures placed in wetlands or waters, and restore natural grades in those areas.
12. All land disturbing activity associated with the highway construction will be conducted in a way that prevents a significant increase in turbidity outside the area of construction or construction-related discharge. Increases such that the turbidity in the water body is 50 NTU's or less is not considered significant.
13. The permittee and its contractors and/or agents shall not excavate, fill, or perform mechanized landclearing at any time in the construction or maintenance of this project within waters and/or wetlands, or cause the degradation of waters and/or wetlands, except as authorized by this permit, or any modification to this permit. There shall be no excavation from, waste disposal into, or degradation of, jurisdictional wetlands or waters associated with this permit without appropriate modification of this permit, including appropriate compensatory mitigation. This prohibition applies to all borrow and fill activities connected with this project.
14. To ensure that all borrow and waste activities occur on high ground and do not result in the degradation of adjacent wetlands and streams, except as authorized by this permit, the permittee shall require its contractors and/or agents to identify all areas to be used to borrow material, or to dispose of dredged, fill, or waste material. The permittee shall ensure that all such areas comply with the preceding condition (13.) of this permit, and shall require and maintain documentation of the location and characteristics of all borrow and disposal sites associated with this project. This information will include data regarding soils, vegetation and hydrology sufficient to clearly demonstrate compliance with the preceding condition (13.). All information will be available to the Corps of Engineers upon request. NCDOT shall require its contractors to complete and execute reclamation plans for each waste and borrow site and provide written documentation that the reclamation plans have been implemented and all work is completed. This

documentation will be provided to the Corps of Engineers within 30 days of the completion of the reclamation work. All jurisdictional wetland lines on borrow and waste sites shall be verified by the Corps of Engineers and shown on the approved reclamation plans.

# WETLAND LEGEND

— WLB — WETLAND BOUNDARY

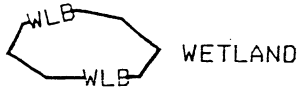

DENOTES FILL IN WETLAND

DENOTES FILL IN SURFACE WATER

DENOTES FILL IN SURFACE WATER (POND)

DENOTES TEMPORARY FILL IN WETLAND

DENOTES EXCAVATION IN WETLAND

DENOTES TEMPORARY FILL IN SURFACE WATER

DENOTES MECHANIZED CLEARING

→ → FLOW DIRECTION

— TB — TOP OF BANK

— WE — EDGE OF WATER

— C — PROP. LIMIT OF CUT

— E — PROP. LIMIT OF FILL

▲ — PROP. RIGHT OF WAY

— NG — NATURAL GROUND

— PL — PROPERTY LINE

— TDE — TEMP. DRAINAGE EASEMENT

— PDE — PERMANENT DRAINAGE EASEMENT

— EAB — EXIST. ENDANGERED ANIMAL BOUNDARY

— EPB — EXIST. ENDANGERED PLANT BOUNDARY

▽ — WATER SURFACE

X X X  
X X X  
X X X  
LIVE STAKES

BOULDER

— CORE FIBER ROLLS

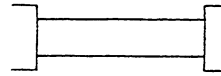

PROPOSED BRIDGE

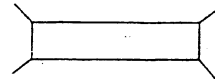

PROPOSED BOX CULVERT

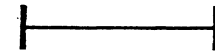

PROPOSED PIPE CULVERT

12"-48"  
PIPES

54" PIPES  
& ABOVE

(DASHED LINES DENOTE  
EXISTING STRUCTURES)



SINGLE TREE



WOODS LINE

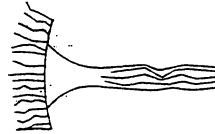

DRAINAGE INLET

ROOTWAD



RIP RAP



ADJACENT PROPERTY  
OWNER OR PARCEL  
NUMBER (IF AVAILABLE)



PREFORMED SCOUR HOLE

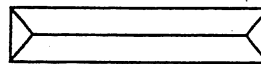

LEVEL SPREADER (LS)

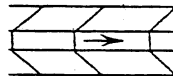

DITCH /  
GRASS SWALE

## NCDOT

DIVISION OF HIGHWAYS  
NEW HANOVER COUNTY

PROJECT: 8.2251101 (B-3496)

BRIDGE NO. 10 OVER BRADLEY

CREEK ON SR 1411

IN WILMINGTON

# PROPERTY OWNERS

## NAMES AND ADDRESSES

PARCEL NO.	NAMES	ADDRESSES
3	CarolAnn Russell	110 Hooker Rd. Wilmington, NC 28403
4	James A and Holly A Hug	1601 Southwind Way Wilmington, NC 28403

**NCDOT**

**DIVISION OF HIGHWAYS**

**NEW HANOVER COUNTY**

**PROJECT: 8.2251101 (B-3496)**

**BRIDGE NO. 10 OVER BRADLEY**

**CREEK ON SR 1411**

**IN WILMINGTON**

REVISIONS

-L-  
PI Sta 14+33.3  
Δ = 15° 33' 58.6" (RT)  
D = 5' 00" 00.0"  
L = 311.33'  
T = 156.63'  
R = 145.92'  
SE = SEE PLANS

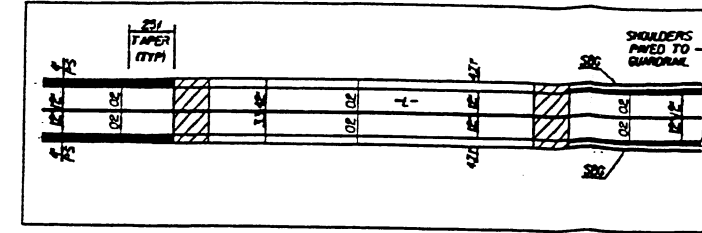

RELATIONSHIP OF PAVEMENT TO BRIDGE

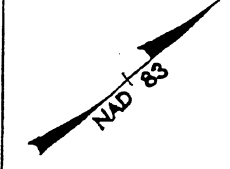

PROJECT REFERENCE NO.	SHEET
B-3496	4
RAW SHEET NO.	
ROADWAY DESIGN ENGINEER	HYDRAULICS ENGINEER

NCDOT  
DIVISION OF HIGHWAYS  
NEW HAMOVER COUNTY  
PROJECT # 2001 02-040  
REPLACE BRIDGE N. 18 ON SR 114  
OVER BRADLEY CREEK  
Revised  
4/28/2004

STA. 14+00.00 -L-  
BEGIN TIP PROJECT B-3496

STA. 22+00.00 -L- END TIP PROJECT B-3496

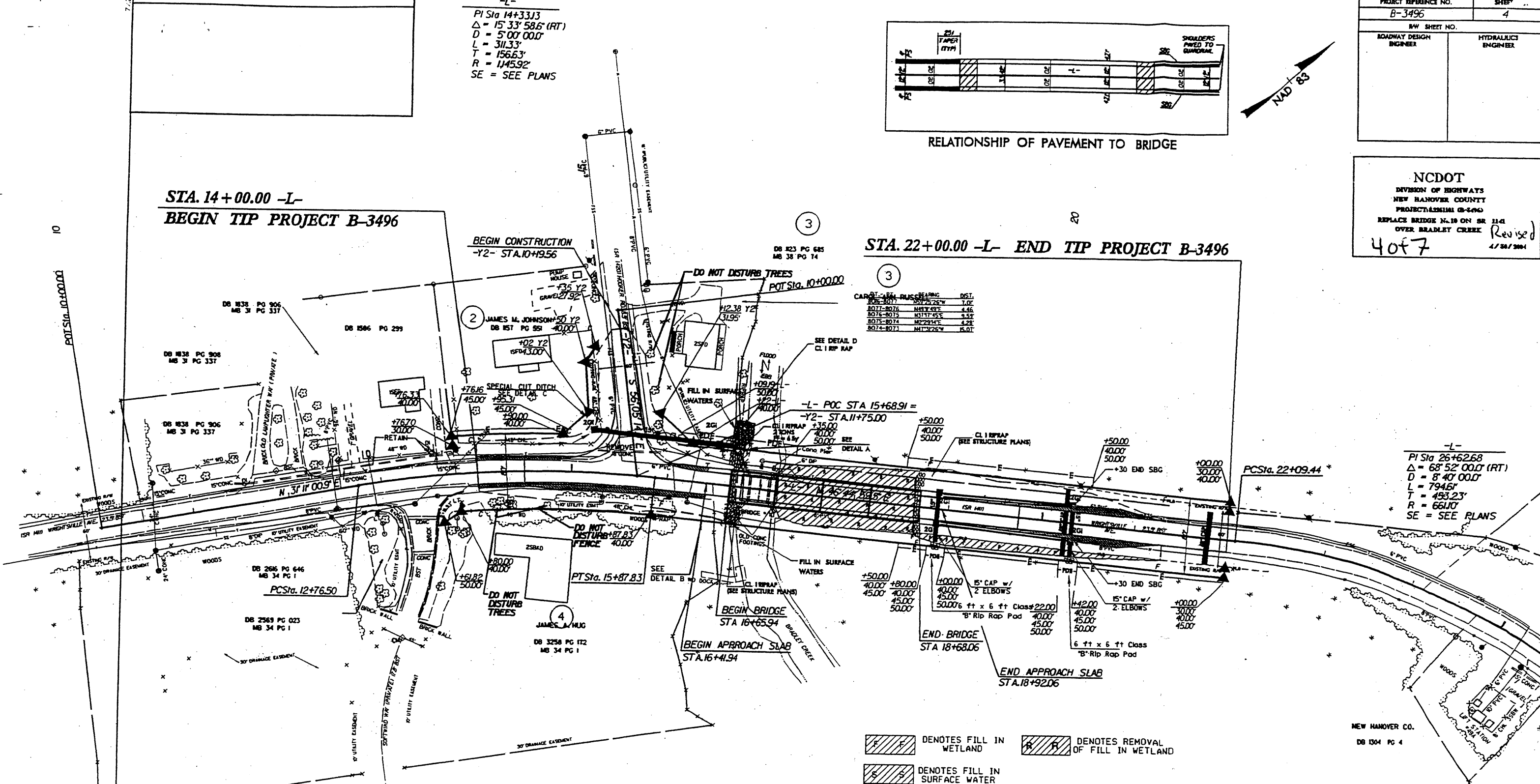

CARD	NO.	BEARING	DIST.
801-807	1	N 25° 22' W	1.00
807-807	2	N 87° 43' E	4.46
807-807	3	N 117° 45' E	9.57
807-807	4	N 27° 24' E	4.28
807-807	5	N 11° 25' W	6.07

-L-  
PI Sta 26+62.68  
Δ = 68° 52' 00.0" (RT)  
D = 8' 40" 00.0"  
L = 794.61'  
T = 493.23'  
R = 661.0'  
SE = SEE PLANS

- DENOTES FILL IN WETLAND
- DENOTES REMOVAL OF FILL IN WETLAND
- DENOTES FILL IN SURFACE WATER

**DATUM DESCRIPTION**  
THE LOCALIZED COORDINATE SYSTEM DEVELOPED FOR THIS PROJECT IS BASED ON THE STATE PLANE COORDINATES ESTABLISHED BY NCDOT FOR MONUMENT "B3496-2" WITH NAD 83 STATE PLANE GRID COORDINATES OF NORTHING: 17,384,100(11) EASTING: 234,878,146(11) THE AVERAGE COMBINED GRID FACTOR USED ON THIS PROJECT (GROUND TO GRID) IS: 1.000038649 THE N.C. LAMBERT GRID BEARING LOCALIZED HORIZONTAL GROUND DISTANCE FROM "B3496-2" TO -L- STATION 14+00.00 IS S 42° 07' 24.26" E DISTANCE 640,118.5 FT. ALL LINEAR DIMENSIONS ARE LOCALIZED HORIZONTAL DISTANCES VERTICAL DATUM USED IS MVD 29

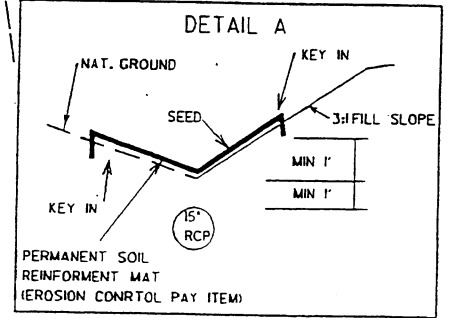

STATION 16+50 TO 16+70 -L- L+

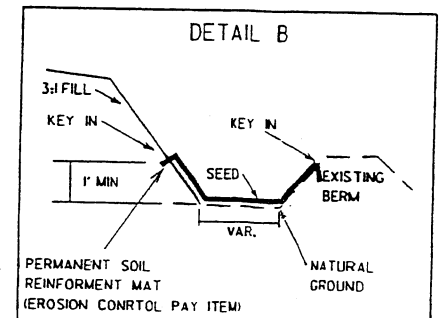

STATION 16+00 TO 16+50 -L- R+

FOR SPECIAL CUT DITCH RIGHT OF STA 14+50 TO 15+50 -L- SEE CROSS SECTIONS

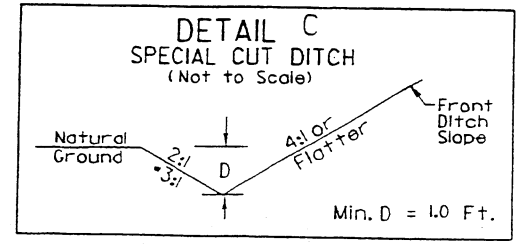

• STA 14+50 TO 15+25 -L- L+  
STA 10+50 TO 11+35 -Y2- R+

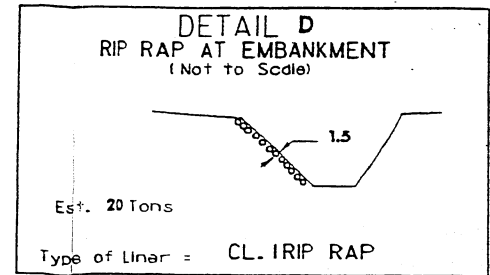

FOR -L- & -Y2- PROFILE SEE SHEET 5  
FOR STRUCTURE PLANS SEE SHEETS S-1 THRU S-28

2004-08-17  
B-3496.dwg  
1:1

-L-  
PI Sta 14+33.3  
Δ = 15° 33' 58.6" (RT)  
D = 5' 00' 00.0"  
L = 311.33'  
T = 156.63'  
R = 145.92'  
SE = SEE PLANS

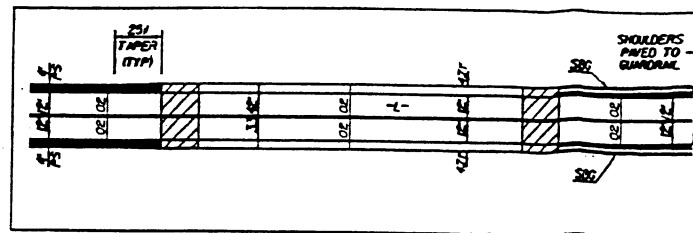

RELATIONSHIP OF PAVEMENT TO BRIDGE

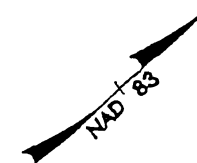

PROJECT REFERENCE NO. B-3496	
SHEET NO. 4	
ROADWAY DESIGN ENGINEER	HYDRAULICS ENGINEER

NCDOT  
DIVISION OF HIGHWAYS  
NEW HANOVER COUNTY  
PROJECT: BRIDGE B-3496  
REPLACE BRIDGE No. 18 ON SR 114  
OVER BRADLEY CREEK  
5 of 7  
Revised 1/28/2004

STA. 14+00.00 -L-  
BEGIN TIP PROJECT B-3496

STA. 22+00.00 -L- END TIP PROJECT B-3496

CARD	BEARING	DIST.
806-8071	N 25° 26' W	1.02
8071-8076	N 43° 45' E	4.46
8076-8075	N 17° 45' E	9.53
8075-8074	N 27° 14' E	4.28
8074-8073	N 1° 25' W	5.01

Enhancement

-L-  
PI Sta 26+62.68  
Δ = 68° 52' 00.0" (RT)  
D = 8' 40' 00.0"  
L = 794.6'  
T = 453.23'  
R = 661.0'  
SE = SEE PLANS

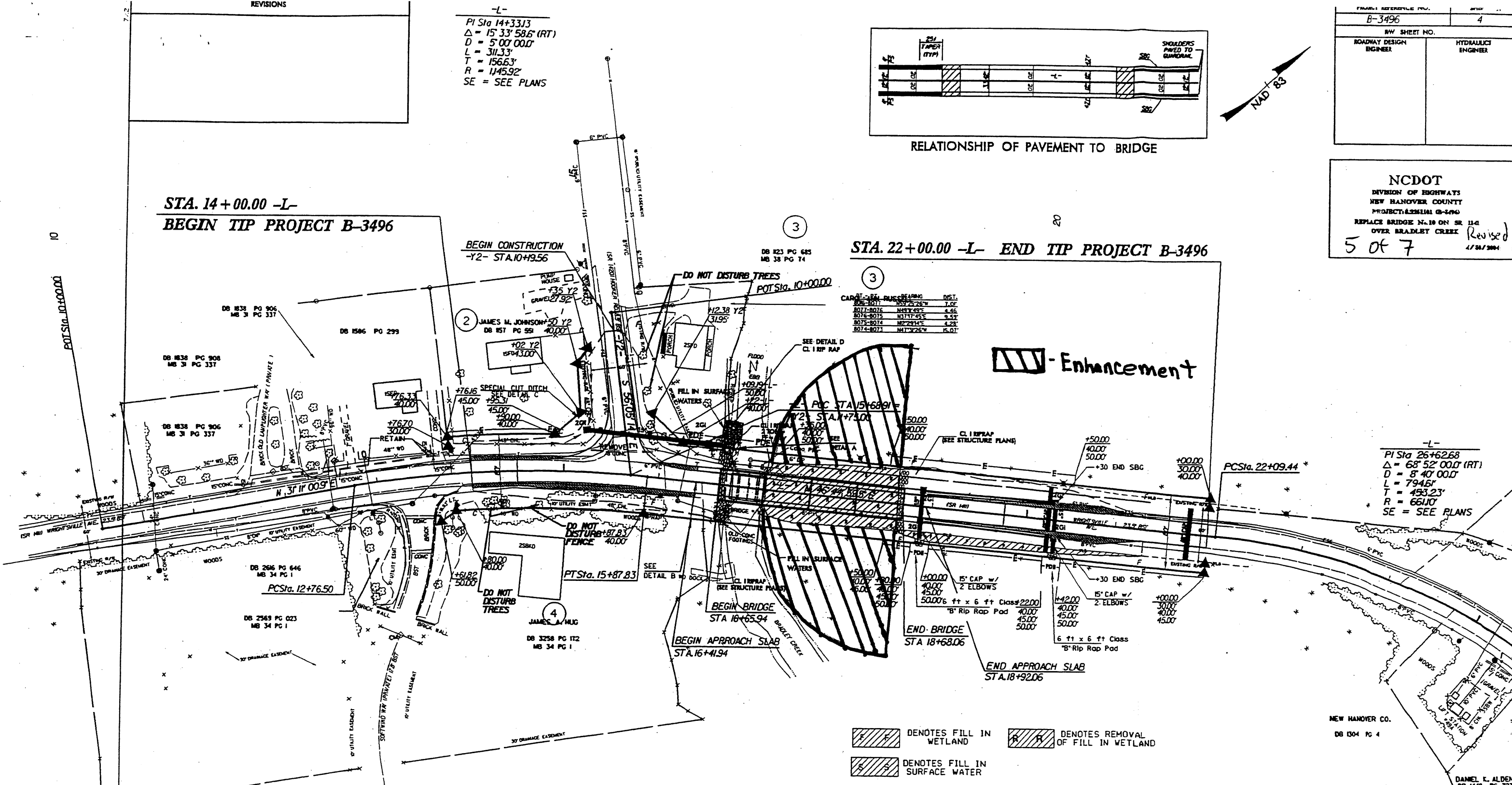

- DENOTES FILL IN WETLAND
- DENOTES REMOVAL OF FILL IN WETLAND
- DENOTES FILL IN SURFACE WATER

**DATUM DESCRIPTION**  
THE LOCALIZED COORDINATE SYSTEM DEVELOPED FOR THIS PROJECT IS BASED ON THE STATE PLANE COORDINATES ESTABLISHED BY NCDOT FOR MONUMENT "B3496-2" WITH NAD 83 STATE PLANE GRID COORDINATES OF NORTHING: 17,384,120.8711 EASTING: 234,878.146711 THE AVERAGE COMBINED GRID FACTOR USED ON THIS PROJECT (GROUND TO GRID) IS: 1.000038649 THE N.C. LAMBERT GRID BEARING LOCALIZED HORIZONTAL GROUND DISTANCE FROM "B3496-2" TO + STATION 14+00.00 IS S 42° 07' 24.26" E DISTANCE 640.1185 FT. ALL LINEAR DIMENSIONS ARE LOCALIZED HORIZONTAL DISTANCES VERTICAL DATUM USED IS MVD 29

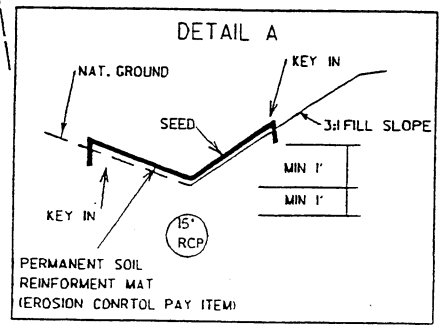

STATION 16+50 TO 16+70 -L- L+

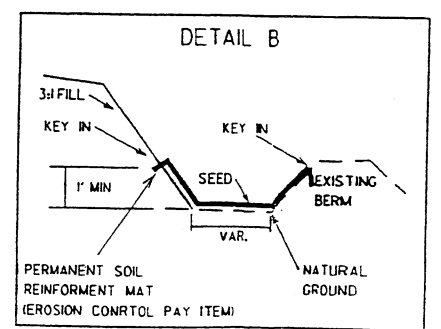

STATION 16+00 TO 16+50 -L- R+

FOR SPECIAL CUT DITCH RIGHT OF STA 14+50 TO 15+50 -L- SEE CROSS SECTIONS

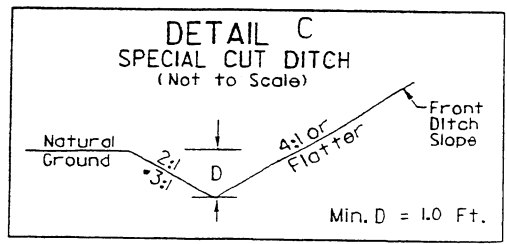

• STA 14+50 TO 15+25 -L- L+  
• STA 10+50 TO 11+35 -Y2- R+

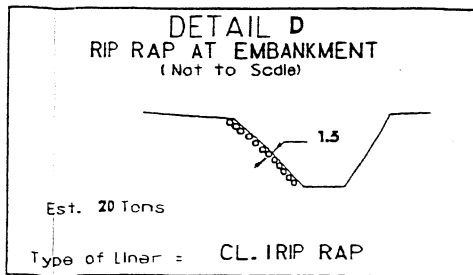

FOR -L- & -Y2- PROFILE SEE SHEET 5  
FOR STRUCTURE PLANS SEE SHEETS S-1 THRU S-28



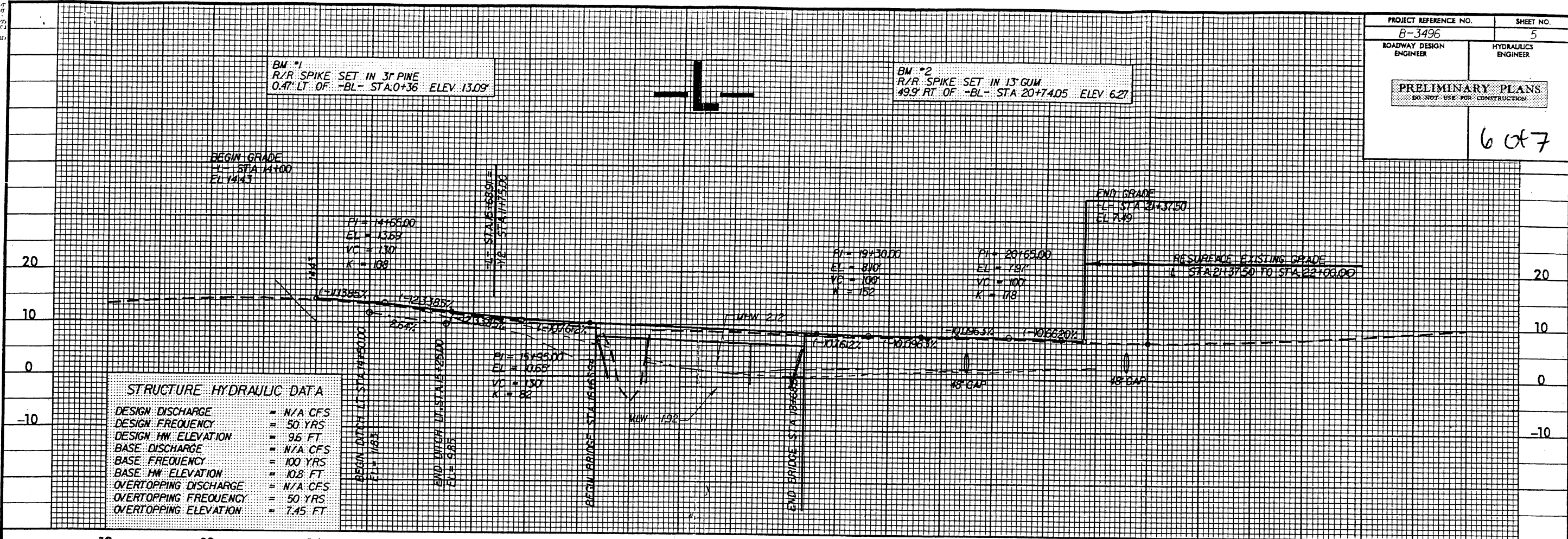

-Y2-

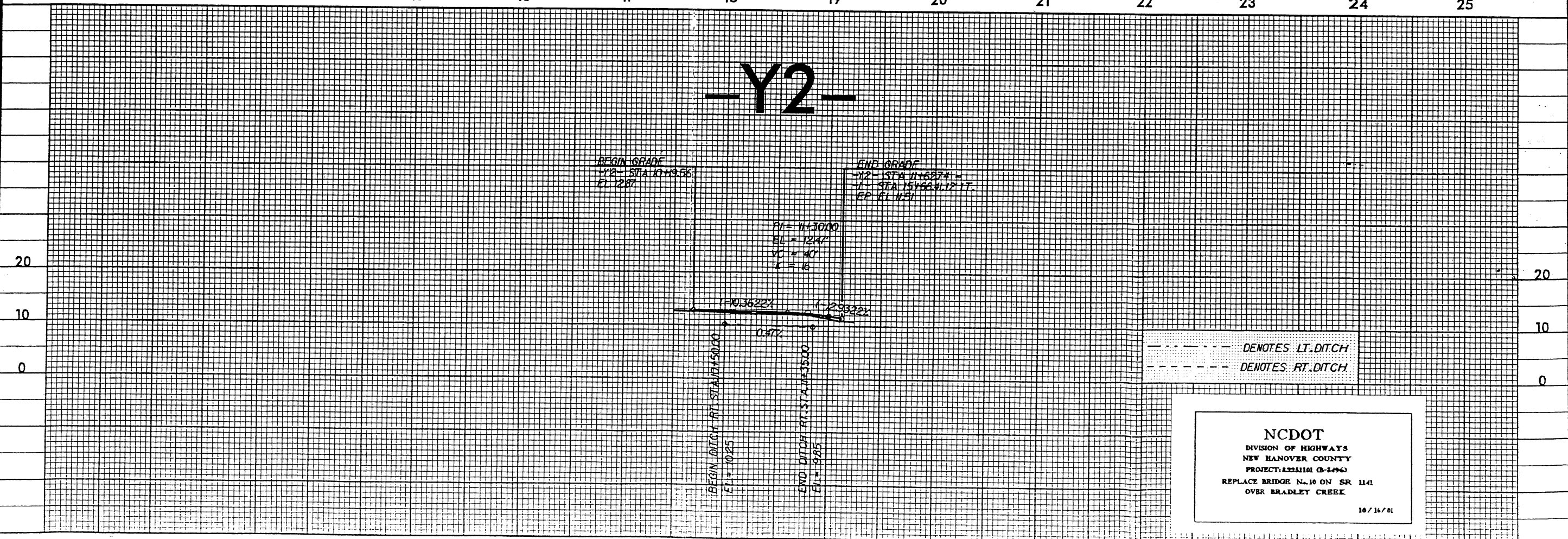

**NCDOT**  
 DIVISION OF HIGHWAYS  
 NEW HAMOVER COUNTY  
 PROJECT: 83241101 0-1496  
 REPLACE BRIDGE N.10 ON SR 1141  
 OVER BRADLEY CREEK  
 10/16/01

10/16/01 10:05 AM  
 C:\p20\files\B3496.p1



**WETLAND PERMIT IMPACT SUMMARY**

Site No.	Station (From/To)	Structure Size / Type	WETLAND IMPACTS				SURFACE WATER IMPACTS				
			Fill In Wetlands (ac)	Temp. Fill In Wetlands (ac)	Removal Of Fill In Wetlands (ac)	Mechanized Clearing (Method III) (ac)	Fill In SW (Natural) (ac)	Fill In SW (Pond) (ac)	Temp. Fill In SW (ac)	Existing Channel Impacted (ft)	Natural Stream Design (ft)
1	16+00 to 22+00-L-	200' Cored Slab Bridge	0.04	0	0.19	0	0.025	0	0	48	0
<b>TOTALS:</b>			0.04	0	0.19	0	0.025	0	0	48	0

NC DEPARTMENT OF TRANSPORTATION  
DIVISION OF HIGHWAYS

NEW HANOVER COUNTY  
PROJECT 8.2551101 (B-3496)

SHEET 7 OF 7

Rev 5/04

4/30/2004

CONTRACT: C200889 TIP PROJECT: B-3496

See Sheet 1-A For Index of Sheets  
See Sheet 1-B For Conventional Symbols

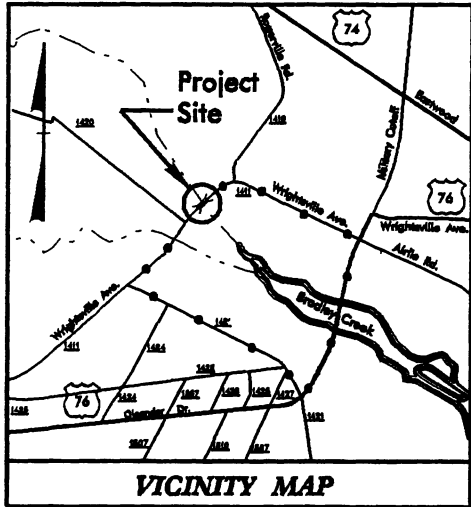

DETOUR ROUTE

STATE OF NORTH CAROLINA  
DIVISION OF HIGHWAYS

**NEW HANOVER COUNTY**

LOCATION: BRIDGE No. 10 OVER BRADLEY CREEK  
ON SR 1411 IN WILMINGTON

TYPE OF WORK: GRADING, DRAINAGE, STRUCTURE,  
AND PAVING

STATE	STATE PROJECT REFERENCE NO.	SHEET NO.	TOTAL SHEETS
N.C.	B-3496	1	
STATE PROJ. NO.	F.A. PROJ. NO.	DESCRIPTION	
33111.1.1	BRSTP-1411(5)	PE	
33111.2.1	BRSTP-1411(5)	RW & UTIL.	
33111.3.1	BRSTP-1411(6)	CONST.	

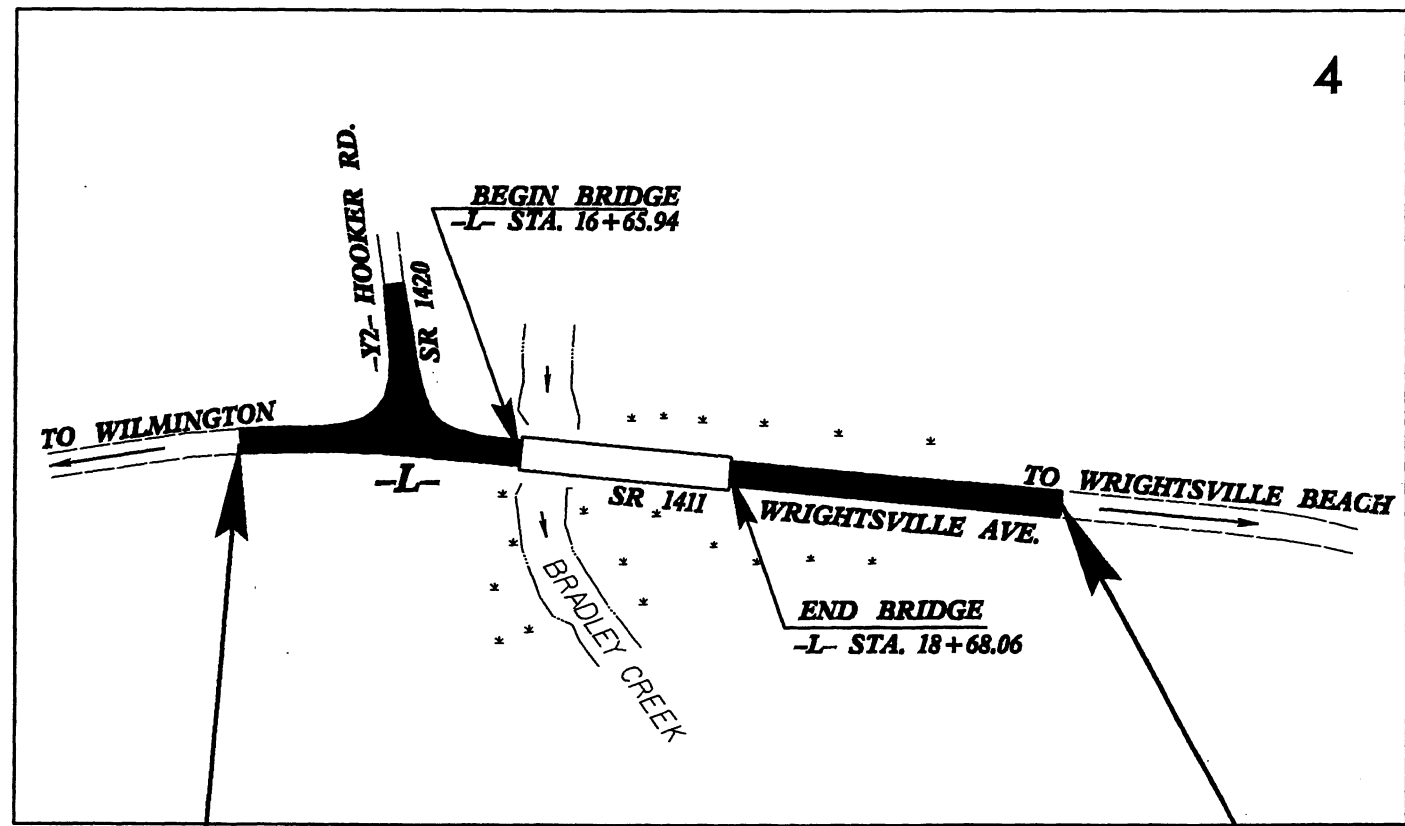

STA. 14+00.00 -L- BEGIN TIP PROJECT B-3496

STA. 22+00.00 -L- END TIP PROJECT B-3496

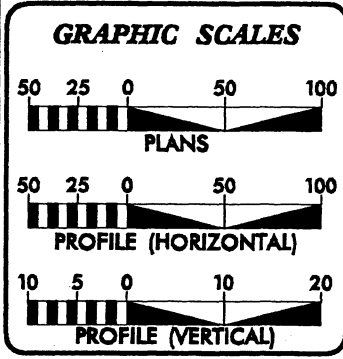

**DESIGN DATA**

ADT 2004 =	13,224
ADT 2024 =	20,344
DHV =	9 %
D =	50 %
T =	5 % *
V =	50 MPH
* TTST 2%	DUAL 3%

**PROJECT LENGTH**

LENGTH OF ROADWAY TIP PROJECT B-3496	=	0.114 MI
LENGTH OF STRUCTURE TIP PROJECT B-3496	=	0.038 MI
TOTAL LENGTH OF TIP PROJECT B-3496	=	0.152 MI

Prepared in the Office of:  
**DIVISION OF HIGHWAYS**  
1000 Birch Ridge Dr., Raleigh, NC 27610

2002 STANDARD SPECIFICATIONS

RIGHT OF WAY DATE:  
APRIL 17, 2003

LETTING DATE:  
JULY 20, 2004

BRENDA MOORE, PE  
PROJECT ENGINEER

ROGER KLUCKMAN, PE  
PROJECT DESIGN ENGINEER

HYDRAULICS ENGINEER

SIGNATURE: \_\_\_\_\_ P.E.

ROADWAY DESIGN ENGINEER

SIGNATURE: \_\_\_\_\_ P.E.

DIVISION OF HIGHWAYS  
STATE OF NORTH CAROLINA

STATE DESIGN ENGINEER

DEPARTMENT OF TRANSPORTATION  
FEDERAL HIGHWAY ADMINISTRATION

APPROVED

03-MAY-2004 11:20  
R:\Projects\B-3496\218b

STATE OF NORTH CAROLINA  
DIVISION OF HIGHWAYS

CONVENTIONAL SYMBOLS

\*S.U.E = SUBSURFACE UTILITY ENGINEER

ROADS & RELATED ITEMS

Edge of Pavement	-----
Curb	-----
Prop. Slope Stakes Cut	----- C
Prop. Slope Stakes Fill	----- F
Prop. Woven Wire Fence	-----
Prop. Chain Link Fence	-----
Prop. Barbed Wire Fence	-----
Prop. Wheelchair Ramp	----- WCR
Curb Cut for Future Wheelchair Ramp	----- CCR
Exist. Guardrail	-----
Prop. Guardrail	-----
Exist. Cable Guiderail	-----
Prop. Cable Guiderail	-----
Equality Symbol	-----
Pavement Removal	-----

RIGHT OF WAY

Baseline Control Point	-----
Existing Right of Way Marker	-----
Exist. Right of Way Line w/Marker	-----
Prop. Right of Way Line with Proposed	-----
R/W Marker (Iron Pin & Cap)	-----
Prop. Right of Way Line with Proposed	-----
(Concrete or Granite) R/W Marker	-----
Exist. Control of Access Line	-----
Prop. Control of Access Line	-----
Exist. Easement Line	-----
Prop. Temp. Construction Easement Line	-----
Prop. Temp. Drainage Easement Line	----- TDE
Prop. Perm. Drainage Easement Line	----- PDE

HYDROLOGY

Stream or Body of Water	-----
River Basin Buffer	-----
Flow Arrow	-----
Disappearing Stream	-----
Spring	-----
Swamp Marsh	-----
Shoreline	-----
Falls, Rapids	-----
Prop Lateral, Tail, Head Ditches	-----

STRUCTURES

MAJOR	
Bridge, Tunnel, or Box Culvert	----- CONC
Bridge Wing Wall, Head Wall and End Wall	----- CONC WW

MINOR

Head & End Wall	----- CONC HW
Pipe Culvert	-----
Footbridge	-----
Drainage Boxes	----- CB
Paved Ditch Gutter	-----

UTILITIES

Exist. Pole	-----
Exist. Power Pole	-----
Prop. Power Pole	-----
Exist. Telephone Pole	-----
Prop. Telephone Pole	-----
Exist. Joint Use Pole	-----
Prop. Joint Use Pole	-----
Telephone Pedestal	-----
Cable TV Pedestal	-----
Hydrant	-----
Satellite Dish	-----
Exist. Water Valve	-----
Sewer Clean Out	-----
Power Manhole	-----
Telephone Booth	-----
Water Manhole	-----
Light Pole	-----
H-Frame Pole	-----
Power Line Tower	-----
Pole with Base	-----
Gas Valve	-----
Gas Meter	-----
Telephone Manhole	-----
Power Transformer	-----
Sanitary Sewer Manhole	-----
Storm Sewer Manhole	-----
Tank; Water, Gas, Oil	-----
Water Tank With Legs	-----
Traffic Signal Junction Box	-----
Fiber Optic Splice Box	-----
Television or Radio Tower	-----
Utility Power Line Connects to Traffic Signal Lines Cut Into the Pavement	----- TS

Recorded Water Line	-----
Designated Water Line (S.U.E.*)	-----
Sanitary Sewer	----- SS
Recorded Sanitary Sewer Force Main	----- FSS
Designated Sanitary Sewer Force Main(S.U.E.*)	----- FSS
Recorded Gas Line	----- G
Designated Gas Line (S.U.E.*)	----- G
Storm Sewer	----- S
Recorded Power Line	----- P
Designated Power Line (S.U.E.*)	----- P
Recorded Telephone Cable	----- T
Designated Telephone Cable (S.U.E.*)	----- T
Recorded U/G Telephone Conduit	----- TC
Designated U/G Telephone Conduit (S.U.E.*)	----- TC
Unknown Utility (S.U.E.*)	----- ZUTL
Recorded Television Cable	----- TV
Designated Television Cable (S.U.E.*)	----- TV
Recorded Fiber Optics Cable	----- FO
Designated Fiber Optics Cable (S.U.E.*)	----- FO
Exist. Water Meter	-----
U/G Test Hole (S.U.E.*)	-----
Abandoned According to U/G Record	----- ATTUR
End of Information	----- E.O.I.

BOUNDARIES & PROPERTIES

State Line	-----
County Line	-----
Township Line	-----
City Line	-----
Reservation Line	-----
Property Line	-----
Property Line Symbol	----- PL
Exist. Iron Pin	----- EP
Property Corner	-----
Property Monument	----- ECM
Property Number	----- 123
Parcel Number	----- 6
Fence Line	----- WW & ISBW
Existing Wetland Boundaries	----- WLB
Proposed Wetland Boundaries	----- WLB
Existing Endangered Animal Boundaries	----- EAB
Existing Endangered Plant Boundaries	----- EPB

BUILDINGS & OTHER CULTURE

Buildings	-----
Foundations	-----
Area Outline	-----
Gate	-----
Gas Pump Vent or U/G Tank Cap	-----
Church	-----
School	-----
Park	-----
Cemetery	-----
Dam	-----
Sign	-----
Well	-----
Small Mine	-----
Swimming Pool	-----

TOPOGRAPHY

Loose Surface	-----
Hard Surface	-----
Change in Road Surface	-----
Curb	-----
Right of Way Symbol	----- R/W
Guard Post	----- OGP
Paved Walk	-----
Bridge	-----
Box Culvert or Tunnel	-----
Ferry	-----
Culvert	-----
Footbridge	-----
Trail, Footpath	-----
Light House	-----

VEGETATION

Single Tree	-----
Single Shrub	-----
Hedge	-----
Woods Line	-----
Orchard	-----
Vineyard	----- VINEYARD

RAILROADS

Standard Gauge	-----
RR Signal Milepost	-----
Switch	-----

5/28/99

03-MAY-2004 17:20  
M:\Draw at 10:51:23  
11b3496.tsh

6/2/99

# FINAL PAVEMENT SCHEDULE

C1	PROP. APPROX. 1 1/2" ASPHALT CONCRETE SURFACE COURSE, TYPE S9.5B, AT AN AVERAGE RATE OF 188 LBS. PER SQ. YD.
C2	PROP. VAR. DEPTH ASPHALT CONCRETE SURFACE COURSE, TYPE S9.5B, AT AN AVERAGE RATE OF 112 LBS. PER SQ. YD. PER 1" DEPTH. TO BE PLACED IN LAYERS NOT TO EXCEED 1 1/2" IN DEPTH.
D1	PROP. APPROX. 3" ASPHALT CONCRETE INTERMEDIATE COURSE, TYPE I19.0B, AT AN AVERAGE RATE OF 342 LBS. PER SQ. YD.
D2	PROP. VAR. DEPTH ASPHALT CONCRETE INTERMEDIATE COURSE, TYPE I19.0B, AT AN AVERAGE RATE OF 114 LBS. PER SQ. YD. PER 1" DEPTH, TO BE PLACED IN LAYERS NOT LESS THAN 2 1/4" IN DEPTH OR GREATER THAN 4" IN DEPTH.
E1	PROP. APPROX. 4 1/2" ASPHALT CONCRETE BASE COURSE, TYPE B25.0B, AT AN AVERAGE RATE OF 613 LBS. PER SQ. YD.
E2	PROP. VAR. DEPTH ASPHALT CONCRETE BASE COURSE, TYPE B25.0B, AT AN AVERAGE RATE OF 114 LBS. PER SQ. YD. PER 1" DEPTH. TO BE PLACED IN LAYERS NOT LESS THAN 3" IN DEPTH OR GREATER THAN 5 1/2" IN DEPTH.
T	EARTH MATERIAL.
U	EXISTING PAVEMENT.
W	VARIABLE DEPTH ASPHALT PAVEMENT (SEE STANDARD WEDGING DETAIL THIS SHEET).

NOTE: PAVEMENT EDGE SLOPES ARE 1:1 UNLESS SHOWN OTHERWISE.

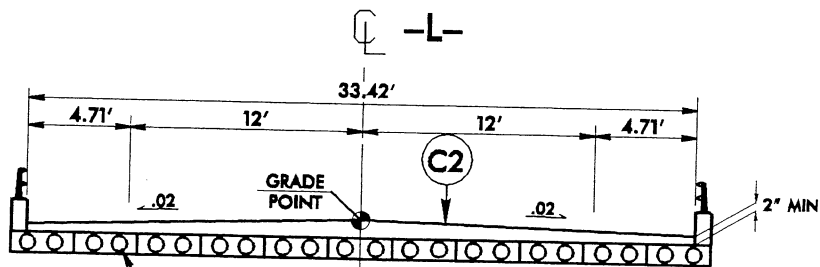
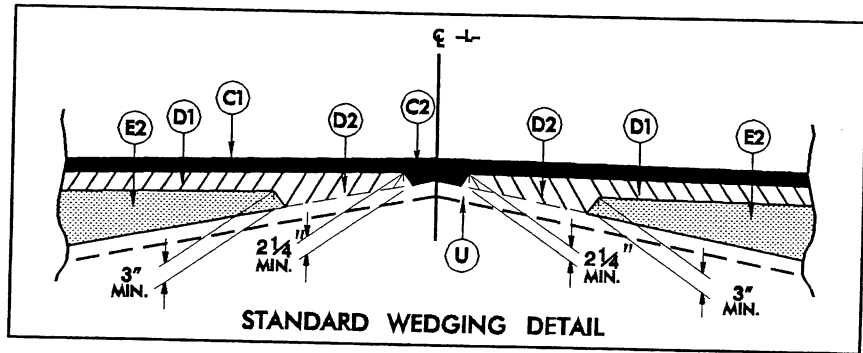

USE TYPICAL SECTION NO. 5

-L- STA. 16+65.94 (BEGIN BRIDGE) TO 18+68.06 (END BRIDGE)

PROJECT REFERENCE NO. B-3496	SHEET NO. 2
ROADWAY DESIGN ENGINEER	PAYMENT DESIGN ENGINEER

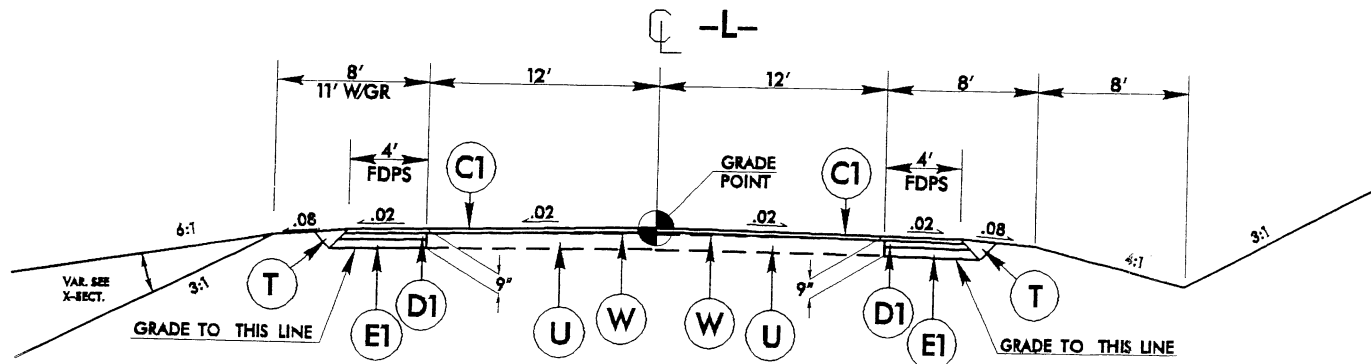

USE TYPICAL SECTION NO. 1

-L- STA. 14+00.00 TO 16+20.00  
-L- STA. 19+00.00 TO 21+30.00

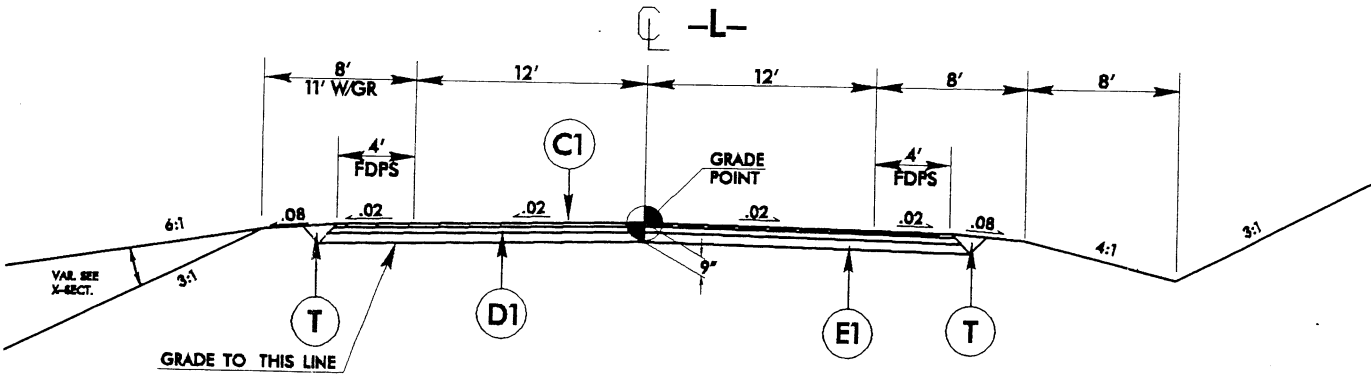

USE TYPICAL SECTION NO. 2

-L- STA. 16+20.00 TO 16+65.94 (BEGIN BRIDGE)  
-L- STA. 18+68.06 (END BRIDGE) TO 19+00.00

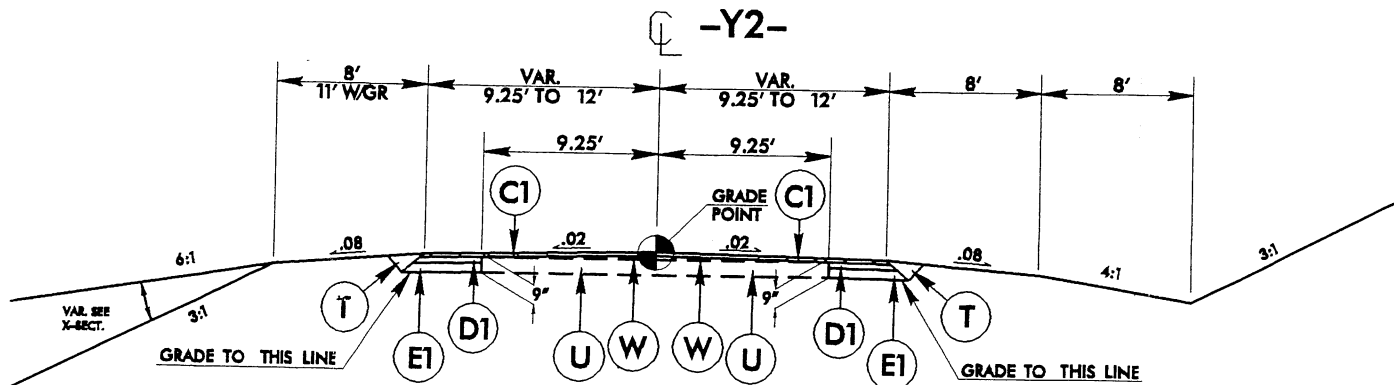

USE TYPICAL SECTION NO. 3

-Y2- STA. 10+19.56 TO 11+62.74

## TYPICAL SECTION No. 3

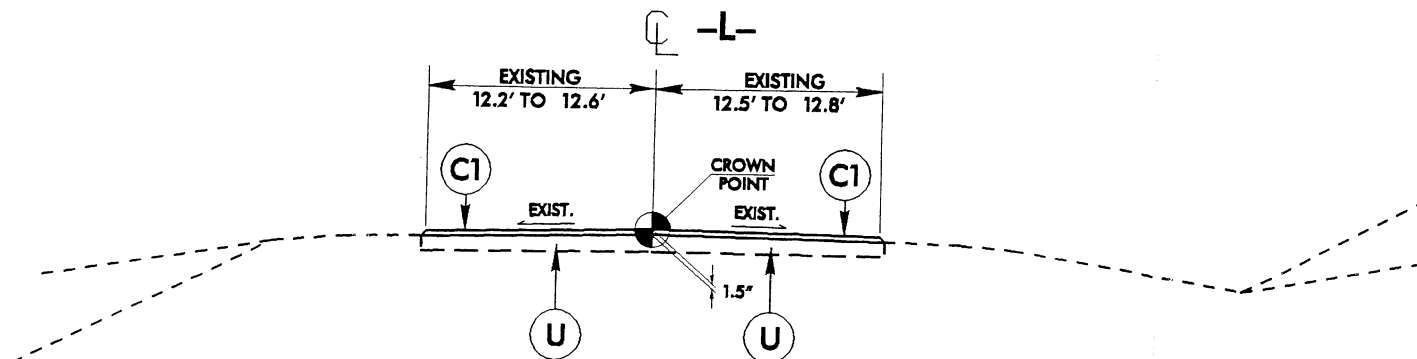

USE TYPICAL SECTION NO. 4

-L- STA. 21+30.00 TO 22+00.00

03-MAY-2004 17:20  
MD-cw AT 10:20:45  
nb3496.twp

7/2/99

REVISIONS	

-L-  
 PI Sta 14+33.3  
 $\Delta = 15' 33" 58.6" (RT)$   
 $D = 5' 00" 00.0"$   
 $L = 311.33'$   
 $T = 156.63'$   
 $R = 1,45.92'$   
 SE = SEE PLANS

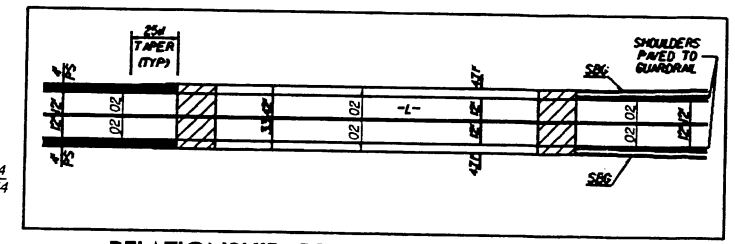
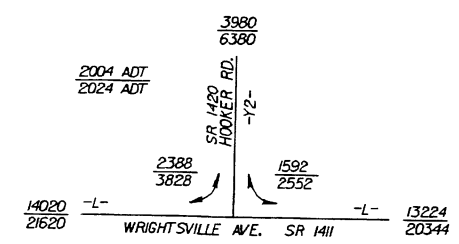

PROJECT REFERENCE NO. B-3496	SHEET NO. 4
RW SHEET NO.	
ROADWAY DESIGN ENGINEER	HYDRAULICS ENGINEER

**STA. 14+00.00 -L-**  
**BEGIN TIP PROJECT B-3496**

**STA. 22+00.00 -L- END TIP PROJECT B-3496**

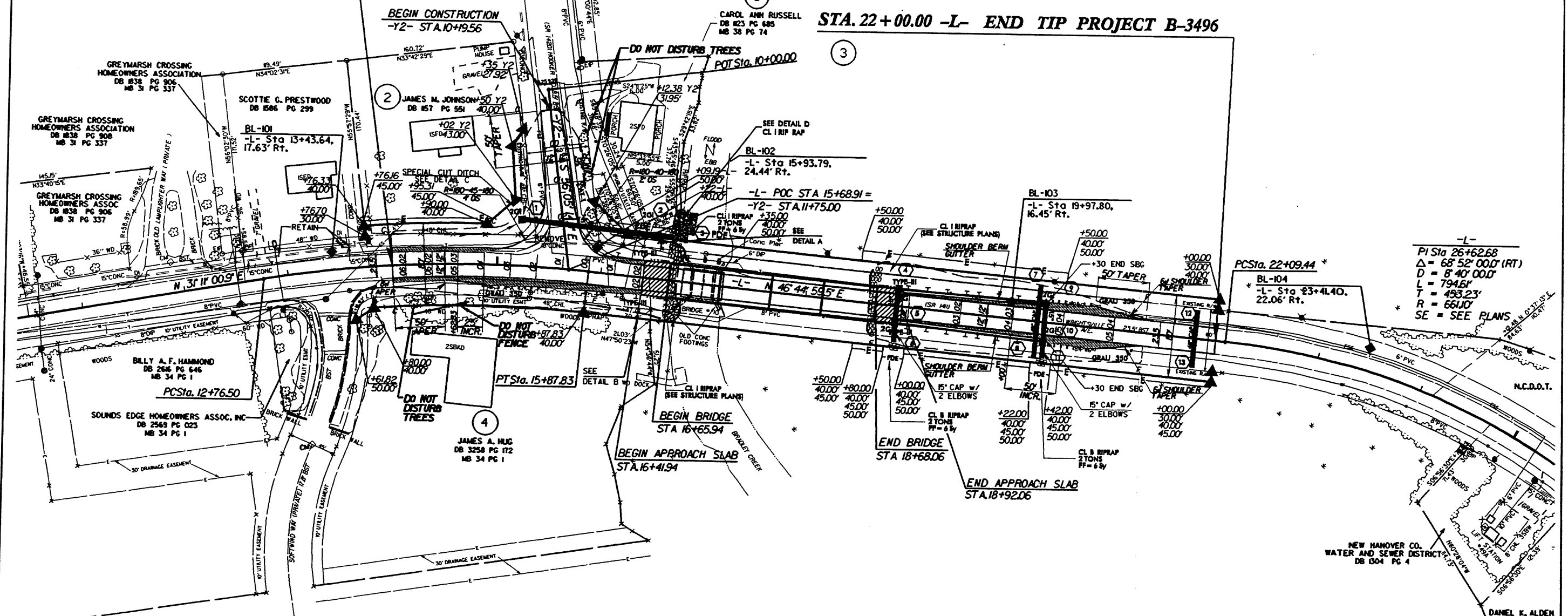

-L-  
 PI Sta 26+62.68  
 $\Delta = 68' 52" 00.0" (RT)$   
 $D = 8' 40" 00.0"$   
 $L = 794.6'$   
 $T = 493.23'$   
 $R = 66.0'$   
 SE = SEE PLANS

**DATUM DESCRIPTION**  
 THE LOCALIZED COORDINATE SYSTEM DEVELOPED FOR THIS PROJECT IS BASED ON THE STATE PLANE COORDINATES ESTABLISHED BY MCDOT FOR MONUMENT "B3496-2" WITH NAD 83 STATE PLANE GRID COORDINATES OF NORTHING: 173841.808(11) EASTING: 234878.114(11) THE AVERAGE COMBINED GRID FACTOR USED ON THIS PROJECT (GROUND TO GRID) IS: 1.00038649 THE N.C. LAMBERT GRID BEARING LOCALIZED HORIZONTAL GROUND DISTANCE FROM "B3496-2" TO -L- STATION 14+00.00 IS S 42° 02' 24.26" E DISTANCE 640.1185 FT. ALL LINEAR DIMENSIONS ARE LOCALIZED HORIZONTAL DISTANCES VERTICAL DATUM USED IS MVD 29

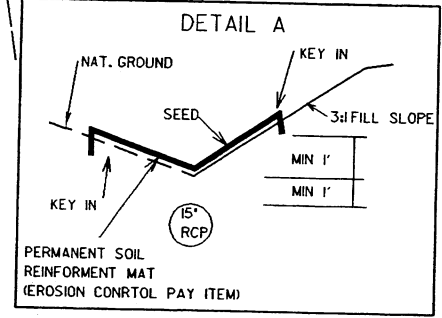

STATION 16+50 TO 16+70 -L- Lt

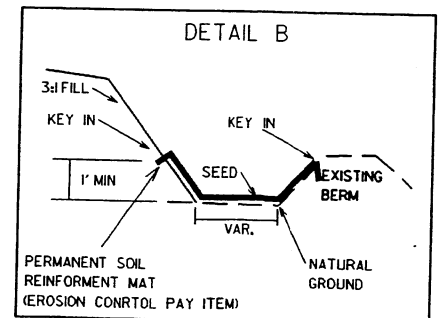

STATION 16+00 TO 16+50 -L- Rt

FOR SPECIAL CUT DITCH RIGHT OF STA 14+50 TO 15+50 -L- SEE CROSS SECTIONS

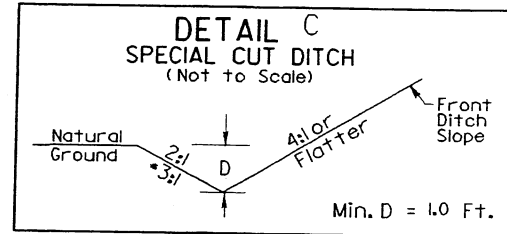

\* STA 14+50 TO 15+25 -L- Lt  
 STA 10+50 TO 11+35 -Y2- Rt

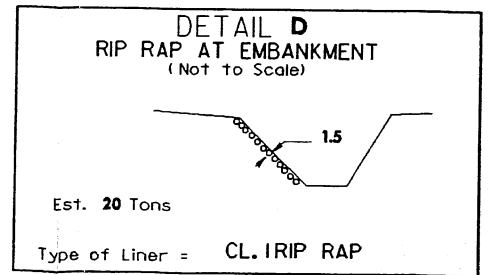

FOR -L- & -Y2- PROFILE SEE SHEET 5

PAVED SHOULDER  
 BRIDGE APPROACH SLAB

04-MAY-2004 08:35  
 R:\projects\B3496\4.psh  
 M.Brannen



PROJECT REFERENCE NO. B-3496	SHEET NO. 5
ROADWAY DESIGN ENGINEER	HYDRAULICS ENGINEER

LT. DITCH - - - - -  
RT. DITCH - - - - -

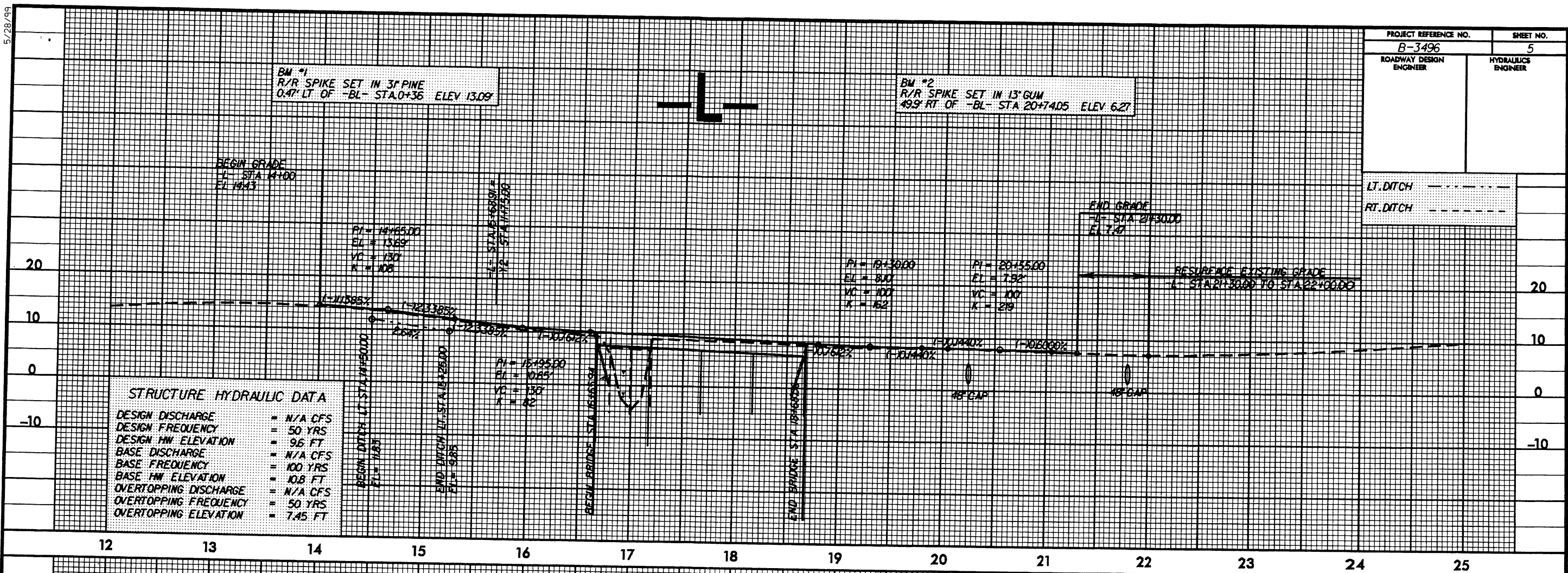

-Y2-

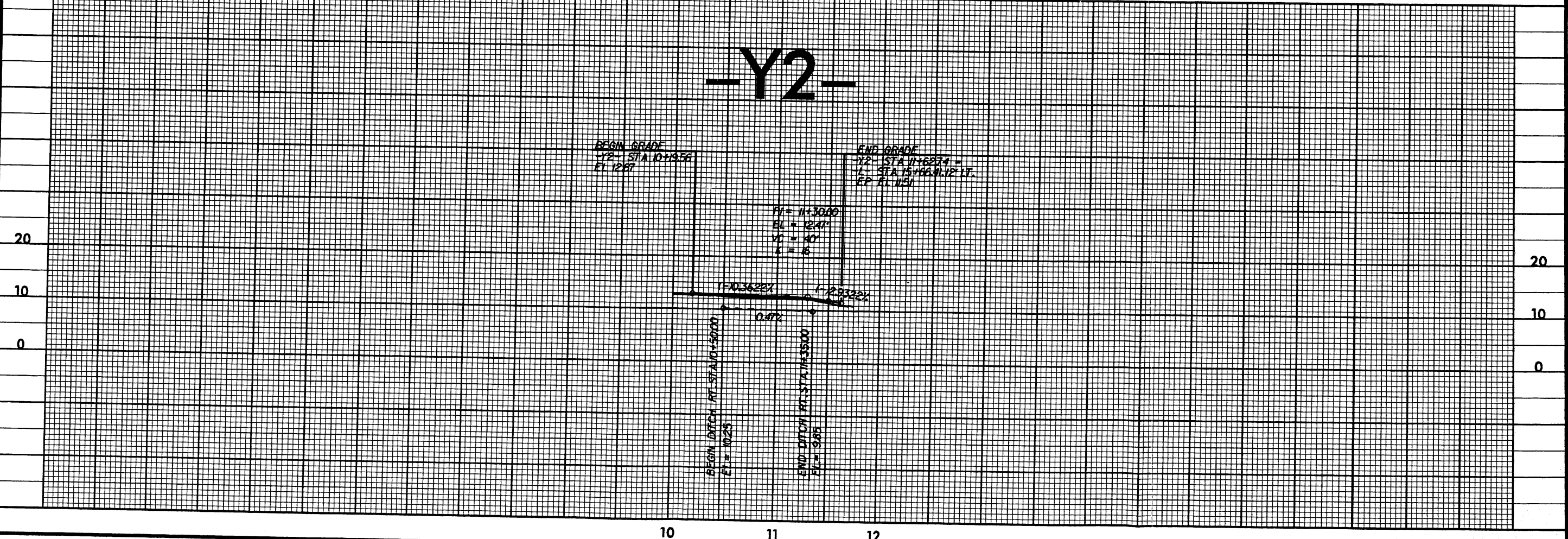

**NATIONWIDE PERMIT 23**  
DEPARTMENT OF THE ARMY  
CORPS OF ENGINEERS  
FINAL NOTICE OF ISSUANCE AND MODIFICATION OF NATIONWIDE PERMITS  
FEDERAL REGISTER  
AUTHORIZED MARCH 18, 2002

**Approved Categorical Exclusions:** Activities undertaken, assisted, authorized, regulated, funded, or financed, in whole or in part, by another Federal agency or department where that agency or department has determined, pursuant to the Council on Environmental Quality Regulation for Implementing the Procedural Provisions of the National Environmental Policy Act (NEPA) (40 CFR part 1500 et seq.), that the activity, work, or discharge is categorically excluded from environmental documentation because it is included within a category of actions which neither individually nor cumulatively have a significant effect on the human environment, and the Office of the Chief of Engineers (ATTN: CECW-OR) has been furnished notice of the agency's or department's application for the categorical exclusion and concurs with that determination. Before to approval for purposes of this nationwide permit of any agency's categorical exclusions, the Chief of Engineers will solicit public comment. In addressing these comments, the Chief of Engineers may require certain conditions for authorization of an agency's categorical exclusions under this nationwide permit. (Sections 10 and 404)

## NATIONWIDE PERMIT GENERAL CONDITIONS

The following General Conditions must be followed in order for any authorization by a NWP to be valid:

1. Navigation. No activity may cause more than a minimal adverse effect on navigation.
2. Proper Maintenance. Any structure or fill authorized shall be properly maintained, including maintenance to ensure public safety.
3. Soil Erosion and Sediment Controls. Appropriate soil erosion and sediment controls must be used and maintained in effective operating condition during construction, and all exposed soil and other fills, as well as any work below the ordinary high water mark or high tide line, must be permanently stabilized at the earliest practicable date. Permittees are encouraged to perform work within waters of the United States during periods of low-flow or no-flow.
4. Aquatic Life Movements. No activity may substantially disrupt the necessary life-cycle movements of those species of aquatic life indigenous to the waterbody, including those species that normally migrate through the area, unless the activity's primary purpose is to impound water. Culverts placed in streams must be installed to maintain low flow conditions.
5. Equipment. Heavy equipment working in wetlands must be placed on mats, or other measures must be taken to minimize soil disturbance.
6. Regional and Case-By-Case Conditions. The activity must comply with any regional conditions that may have been added by the Division Engineer (see 33 CFR 330.4(e)) and with any case specific conditions added by the Corps or by the state or tribe in its Section 401 Water Quality Certification and Coastal Zone Management Act consistency determination.
7. Wild and Scenic Rivers. No activity may occur in a component of the National Wild and Scenic River System; or in a river officially designated by Congress as a 'study river' for possible inclusion in the system, while the river is in an official study status; unless the appropriate Federal agency, with direct management responsibility for such river, has determined in writing that the proposed activity will not adversely affect the Wild and Scenic River designation, or study status. Information on Wild and Scenic Rivers may be obtained from the appropriate Federal land management agency in the area (e.g., National Park Service, U.S. Forest Service, Bureau of Land Management, U.S. Fish and Wildlife Service).
8. Tribal Rights. No activity or its operation may impair reserved tribal rights, including, but not limited to, reserved water rights and treaty fishing and hunting rights.
9. Water Quality.



a. In certain states and tribal lands an individual 401 Water Quality Certification must be obtained or waived (See 33 CFR 330.4(c)).

b. For NWP's 12, 14, 17, 18, 32, 39, 40, 42, 43, and 44, where the state or tribal 401 certification (either generically or individually) does not require or approve water quality management measures, the permittee must provide water quality management measures that will ensure that the authorized work does not result in more than minimal degradation of water quality (or the Corps determines that compliance with state or local standards, where applicable, will ensure no more than minimal adverse effect on water quality). An important component of water quality management includes stormwater management that minimizes degradation of the downstream aquatic system, including water quality (refer to General Condition 21 for stormwater management requirements). Another important component of water quality management is the establishment and maintenance of vegetated buffers next to open waters, including streams (refer to General Condition 19 for vegetated buffer requirements for the NWP's).

This condition is only applicable to projects that have the potential to affect water quality. While appropriate measures must be taken, in most cases it is not necessary to conduct detailed studies to identify such measures or to require monitoring.

10. Coastal Zone Management. In certain states, an individual state coastal zone management consistency concurrence must be obtained or waived (see 33 CFR 330.4(d)).

#### 11. Endangered Species.

a. No activity is authorized under any NWP which is likely to jeopardize the continued existence of a threatened or endangered species or a species proposed for such designation, as identified under the Federal Endangered Species Act (ESA), or which will destroy or adversely modify the critical habitat of such species. Non-federal permittees shall notify the District Engineer if any listed species or designated critical habitat might be affected or is in the vicinity of the project, or is located in the designated critical habitat and shall not begin work on the activity until notified by the District Engineer that the requirements of the ESA have been satisfied and that the activity is authorized. For activities that may affect Federally-listed endangered or threatened species or designated critical habitat, the notification must include the name(s) of the endangered or threatened species that may be affected by the proposed work or that utilize the designated critical habitat that may be affected by the proposed work. As a result of formal or informal consultation with the FWS or NMFS the District Engineer may add species-specific regional endangered species conditions to the NWP's.

b. Authorization of an activity by a NWP does not authorize the "take" of a threatened or endangered species as defined under the ESA. In the absence of separate authorization (e.g., an ESA Section 10 Permit, a Biological Opinion with "incidental take" provisions, etc.) from the USFWS or the NMFS, both lethal and non-lethal "takes" of protected species are in violation of the ESA. Information on the location of threatened and endangered species and their critical

habitat can be obtained directly from the offices of the USFWS and NMFS or their World Wide Web pages at <http://www.fws.gov/r9endspp/endspp.html> and <http://www.nfms.noaa.gov/protres/overview/es.html> respectively.

12. Historic Properties. No activity that may affect historic properties listed, or eligible for listing, in the National Register of Historic Places is authorized, until the District Engineer has complied with the provisions of 33 CFR part 325, Appendix C. The prospective permittee must notify the District Engineer if the authorized activity may affect any historic properties listed, determined to be eligible, or which the prospective permittee has reason to believe may be eligible for listing on the National Register of Historic Places, and shall not begin the activity until notified by the District Engineer that the requirements of the National Historic Preservation Act have been satisfied and that the activity is authorized. Information on the location and existence of historic resources can be obtained from the State Historic Preservation Office and the National Register of Historic Places (see 33 CFR 330.4(g)). For activities that may affect historic properties listed in, or eligible for listing in, the National Register of Historic Places, the notification must state which historic property may be affected by the proposed work or include a vicinity map indicating the location of the historic property.

13. Notification.

a. Timing; where required by the terms of the NWP, the prospective permittee must notify the District Engineer with a preconstruction notification (PCN) as early as possible. The District Engineer must determine if the notification is complete within 30 days of the date of receipt and can request additional information necessary to make the PCN complete only once. However, if the prospective permittee does not provide all of the requested information, then the District Engineer will notify the prospective permittee that the notification is still incomplete and the PCN review process will not commence until all of the requested information has been received by the District Engineer. The prospective permittee shall not begin the activity:

1. Until notified in writing by the District Engineer that the activity may proceed under the NWP with any special conditions imposed by the District or Division Engineer; or

2. If notified in writing by the District or Division Engineer that an Individual Permit is required; or

3. Unless 45 days have passed from the District Engineer's receipt of the complete notification and the prospective permittee has not received written notice from the District or Division Engineer. Subsequently, the permittee's right to proceed under the NWP may be modified, suspended, or revoked only in accordance with the procedure set forth in 33 CFR 330.5(d)(2).

b. Contents of Notification: The notification must be in writing and include the following information:

1. Name, address and telephone numbers of the prospective permittee;

2. Location of the proposed project;

3. Brief description of the proposed project; the project's purpose; direct and indirect adverse environmental effects the project would cause; any other NWP(s), Regional General Permit(s), or Individual Permit(s) used or intended to be used to authorize any part of the proposed project or any related activity. Sketches should be provided when necessary to show that the activity complies with the terms of the NWP (Sketches usually clarify the project and when provided result in a quicker decision.);

4. For NWPs 7, 12, 14, 18, 21, 34, 38, 39, 40, 41, 42, and 43, the PCN must also include a delineation of affected special aquatic sites, including wetlands, vegetated shallows (e.g., submerged aquatic vegetation, seagrass beds), and riffle and pool complexes (see paragraph 13(f));

5. For NWP 7 (Cutfall Structures and Maintenance), the PCN must include information regarding the original design capacities and configurations of those areas of the facility where maintenance dredging or excavation is proposed;

6. For NWP 14 (Linear Transportation Projects), the PCN must include a compensatory mitigation proposal to offset permanent losses of waters of the US and a statement describing how temporary losses of waters of the US will be minimized to the maximum extent practicable;

7. For NWP 21 (Surface Coal Mining Activities), the PCN must include an Office of Surface Mining (OSM) or state-approved mitigation plan, if applicable. To be authorized by this NWP, the District Engineer must determine that the activity complies with the terms and conditions of the NWP and that the adverse environmental effects are minimal both individually and cumulatively and must notify the project sponsor of this determination in writing;

8. For NWP 27 (Stream and Wetland Restoration Activities), the PCN must include documentation of the prior condition of the site that will be reverted by the permittee;

9. For NWP 29 (Single-Family Housing), the PCN must also include:

i. Any past use of this NWP by the Individual Permittee and/or the permittee's spouse;

ii. A statement that the single-family housing activity is for a personal residence of the permittee;

iii. A description of the entire parcel, including its size, and a delineation of wetlands. For the purpose of this NWP, parcels of land measuring  $\frac{1}{4}$ -acre or less will not require a formal on-site delineation. However, the applicant shall provide an indication of where the wetlands are and the amount of wetlands that exists on the property. For parcels greater than

\1/4\ acre in size, formal wetland delineation must be prepared in accordance with the current method required by the Corps. (See paragraph 13(f));

iv. A written description of all land (including, if available, legal descriptions) owned by the prospective permittee and/or the prospective permittee's spouse, within a one mile radius of the parcel, in any form of ownership (including any land owned as a partner, corporation, joint tenant, co-tenant, or as a tenant-by-the-entirety) and any land on which a purchase and sale agreement or other contract for sale or purchase has been executed;

10. For NWP 31 (Maintenance of Existing Flood Control Facilities), the prospective permittee must either notify the District Engineer with a PCN prior to each maintenance activity or submit a five-year (or less) maintenance plan. In addition, the PCN must include all of the following:

i. Sufficient baseline information identifying the approved channel depths and configurations and existing facilities. Minor deviations are authorized, provided the approved flood control protection or drainage is not increased;

ii. A delineation of any affected special aquatic sites, including wetlands; and,

iii. Location of the dredged material disposal site;

11. For NWP 33 (Temporary Construction, Access, and Dewatering), the PCN must also include a restoration plan of reasonable measures to avoid and minimize adverse effects to aquatic resources;

12. For NWPs 39, 43 and 44, the PCN must also include a written statement to the District Engineer explaining how avoidance and minimization for losses of waters of the US were achieved on the project site;

13. For NWP 39 and NWP 42, the PCN must include a compensatory mitigation proposal to offset losses of waters of the US or justification explaining why compensatory mitigation should not be required. For discharges that cause the loss of greater than 300 linear feet of an intermittent stream bed, to be authorized, the District Engineer must determine that the activity complies with the other terms and conditions of the NWP, determine adverse environmental effects are minimal both individually and cumulatively, and waive the limitation on stream impacts in writing before the permittee may proceed;

14. For NWP 40 (Agricultural Activities), the PCN must include a compensatory mitigation proposal to offset losses of waters of the US. This NWP does not authorize the relocation of greater than 300 linear feet of existing serviceable drainage ditches constructed in non-tidal streams unless, for drainage ditches constructed in intermittent nontidal streams, the District Engineer waives this criterion in writing, and the District Engineer has determined that the project complies with all terms and conditions of this NWP, and that any adverse impacts of the project on the aquatic environment are minimal, both individually and cumulatively;

15. For NWP 43 (Stormwater Management Facilities), the PCN must include, for the construction of new stormwater management facilities, a maintenance plan (in accordance with state and local requirements, if applicable) and a compensatory mitigation proposal to offset losses of waters of the US. For discharges that cause the loss of greater than 300 linear feet of an intermittent stream bed, to be authorized, the District Engineer must determine that the activity complies with the other terms and conditions of the NWP, determine adverse environmental effects are minimal both individually and cumulatively, and waive the limitation on stream impacts in writing before the permittee may proceed;

16. For NWP 44 (Mining Activities), the PCN must include a description of all waters of the US adversely affected by the project, a description of measures taken to minimize adverse effects to waters of the US, a description of measures taken to comply with the criteria of the NWP, and a reclamation plan (for all aggregate mining activities in isolated waters and non-tidal wetlands adjacent to headwaters and any hard rock/mineral mining activities);

17. For activities that may adversely affect Federally-listed endangered or threatened species, the PCN must include the name(s) of those endangered or threatened species that may be affected by the proposed work or utilize the designated critical habitat that may be affected by the proposed work; and

18. For activities that may affect historic properties listed in, or eligible for listing in, the National Register of Historic Places, the PCN must state which historic property may be affected by the proposed work or include a vicinity map indicating the location of the historic property.

c. Form of Notification: The standard Individual Permit application form (Form ENG 4345) may be used as the notification but must clearly indicate that it is a PCN and must include all of the information required in (b) (1)-(18) of General Condition 13. A letter containing the requisite information may also be used.

d. District Engineer's Decision: In reviewing the PCN for the proposed activity, the District Engineer will determine whether the activity authorized by the NWP will result in more than minimal individual or cumulative adverse environmental effects or may be contrary to the public interest. The prospective permittee may submit a proposed mitigation plan with the PCN to expedite the process. The District Engineer will consider any proposed compensatory mitigation the applicant has included in the proposal in determining whether the net adverse environmental effects to the aquatic environment of the proposed work are minimal. If the District Engineer determines that the activity complies with the terms and conditions of the NWP and that the adverse effects on the aquatic environment are minimal, after considering mitigation, the District Engineer will notify the permittee and include any conditions the District Engineer deems necessary. The District Engineer must approve any compensatory mitigation proposal before the permittee commences work. If the prospective permittee is required to submit a compensatory mitigation proposal with the PCN, the proposal may be either conceptual or detailed. If the prospective permittee elects to submit a compensatory mitigation plan with the

PCN, the District Engineer will expeditiously review the proposed compensatory mitigation plan. The District Engineer must review the plan within 45 days of receiving a complete PCN and determine whether the conceptual or specific proposed mitigation would ensure no more than minimal adverse effects on the aquatic environment. If the net adverse effects of the project on the aquatic environment (after consideration of the compensatory mitigation proposal) are determined by the District Engineer to be minimal, the District Engineer will provide a timely written response to the applicant. The response will state that the project can proceed under the terms and conditions of the NWP.

If the District Engineer determines that the adverse effects of the proposed work are more than minimal, then the District Engineer will notify the applicant either:

1. That the project does not qualify for authorization under the NWP and instruct the applicant on the procedures to seek authorization under an Individual Permit;
2. that the project is authorized under the NWP subject to the applicant's submission of a mitigation proposal that would reduce the adverse effects on the aquatic environment to the minimal level; or
3. that the project is authorized under the NWP with specific modifications or conditions. Where the District Engineer determines that mitigation is required to ensure no more than minimal adverse effects occur to the aquatic environment, the activity will be authorized within the 45-day PCN period. The authorization will include the necessary conceptual or specific mitigation or a requirement that the applicant submit a mitigation proposal that would reduce the adverse effects on the aquatic environment to the minimal level. When conceptual mitigation is included, or a mitigation plan is required under item (2) above, no work in waters of the US will occur until the District Engineer has approved a specific mitigation plan.

e. Agency Coordination: The District Engineer will consider any comments from Federal and state agencies concerning the proposed activity's compliance with the terms and conditions of the NWPs and the need for mitigation to reduce the project's adverse environmental effects to a minimal level.

For activities requiring notification to the District Engineer that result in the loss of greater than  $\frac{1}{2}$ -acre of waters of the US, the District Engineer will provide immediately (e.g., via facsimile transmission, overnight mail, or other expeditious manner) a copy to the appropriate Federal or state offices (USFWS, state natural resource or water quality agency, EPA, State Historic Preservation Officer (SHPO), and, if appropriate, the NMFS). With the exception of NWP 37, these agencies will then have 10 calendar days from the date the material is transmitted to telephone or fax the District Engineer notice that they intend to provide substantive, site-specific comments. If so contacted by an agency, the District Engineer will wait an additional 15 calendar days before making a decision on the notification. The District Engineer will fully consider agency comments received within the specified time frame, but will provide no response to the resource agency, except as provided below. The District Engineer will indicate in the administrative record associated with each notification that the resource agencies'

concerns were considered. As required by section 305(b)(4)(B) of the Magnuson-Stevens Fishery Conservation and Management Act, the District Engineer will provide a response to NMFS within 30 days of receipt of any Essential Fish Habitat conservation recommendations. Applicants are encouraged to provide the Corps multiple copies of notifications to expedite agency notification.

f. Wetland Delineations: Wetland delineations must be prepared in accordance with the current method required by the Corps (For NWP 29 see paragraph (b)(9)(iii) for parcels less than  $\frac{1}{4}$ -acre in size). The permittee may ask the Corps to delineate the special aquatic site. There may be some delay if the Corps does the delineation. Furthermore, the 45-day period will not start until the wetland delineation has been completed and submitted to the Corps, where appropriate.

14. Compliance Certification. Every permittee who has received NWP verification from the Corps will submit a signed certification regarding the completed work and any required mitigation. The certification will be forwarded by the Corps with the authorization letter and will include:

- a. A statement that the authorized work was done in accordance with the Corps authorization, including any general or specific conditions;
- b. A statement that any required mitigation was completed in accordance with the permit conditions; and
- c. The signature of the permittee certifying the completion of the work and mitigation.

15. Use of Multiple Nationwide Permits. The use of more than one NWP for a single and complete project is prohibited, except when the acreage loss of waters of the US authorized by the NWPs does not exceed the acreage limit of the NWP with the highest specified acreage limit (e.g. if a road crossing over tidal waters is constructed under NWP 14, with associated bank stabilization authorized by NWP 13, the maximum acreage loss of waters of the US for the total project cannot exceed  $\frac{1}{3}$ -acre).

16. Water Supply Intakes. No activity, including structures and work in navigable waters of the US or discharges of dredged or fill material, may occur in the proximity of a public water supply intake except where the activity is for repair of the public water supply intake structures or adjacent bank stabilization.

17. Shellfish Beds. No activity, including structures and work in navigable waters of the US or discharges of dredged or fill material, may occur in areas of concentrated shellfish populations, unless the activity is directly related to a shellfish harvesting activity authorized by NWP 4.

18. Suitable Material. No activity, including structures and work in navigable waters of the US or discharges of dredged or fill material, may consist of unsuitable material (e.g., trash,

debris, car bodies, asphalt, etc.) and material used for construction or discharged must be free from toxic pollutants in toxic amounts (see section 307 of the CWA).

19. Mitigation. The District Engineer will consider the factors discussed below when determining the acceptability of appropriate and practicable mitigation necessary to offset adverse effects on the aquatic environment that are more than minimal.

a. The project must be designed and constructed to avoid and minimize adverse effects to waters of the US to the maximum extent practicable at the project site (i.e., on site).

b. Mitigation in all its forms (avoiding, minimizing, rectifying, reducing or compensating) will be required to the extent necessary to ensure that the adverse effects to the aquatic environment are minimal.

c. Compensatory mitigation at a minimum one-for-one ratio will be required for all wetland impacts requiring a PCN, unless the District Engineer determines in writing that some other form of mitigation would be more environmentally appropriate and provides a project-specific waiver of this requirement. Consistent with National policy, the District Engineer will establish a preference for restoration of wetlands as compensatory mitigation, with preservation used only in exceptional circumstances.

d. Compensatory mitigation (i.e., replacement or substitution of aquatic resources for those impacted) will not be used to increase the acreage losses allowed by the acreage limits of some of the NWPs. For example,  $\frac{1}{4}$ -acre of wetlands cannot be created to change a  $\frac{3}{4}$ -acre loss of wetlands to a  $\frac{1}{2}$ -acre loss associated with NWP 39 verification. However,  $\frac{1}{2}$ -acre of created wetlands can be used to reduce the impacts of a  $\frac{1}{2}$ -acre loss of wetlands to the minimum impact level in order to meet the minimal impact requirement associated with NWPs.

e. To be practicable, the mitigation must be available and capable of being done considering costs, existing technology, and logistics in light of the overall project purposes. Examples of mitigation that may be appropriate and practicable include, but are not limited to: reducing the size of the project; establishing and maintaining wetland or upland vegetated buffers to protect open waters such as streams; and replacing losses of aquatic resource functions and values by creating, restoring, enhancing, or preserving similar functions and values, preferably in the same watershed.

f. Compensatory mitigation plans for projects in or near streams or other open waters will normally include a requirement for the establishment, maintenance, and legal protection (e.g., easements, deed restrictions) of vegetated buffers to open waters. In many cases, vegetated buffers will be the only compensatory mitigation required. Vegetated buffers should consist of native species. The width of the vegetated buffers required will address documented water quality or aquatic habitat loss concerns. Normally, the vegetated buffer will be 25 to 50 feet wide on each side of the stream, but the District Engineers may require slightly wider vegetated buffers to address documented water quality or habitat loss concerns. Where both wetlands and



open waters exist on the project site, the Corps will determine the appropriate compensatory mitigation (e.g., stream buffers or wetlands compensation) based on what is best for the aquatic environment or, a watershed basis. In cases where vegetated buffers are determined to be the most appropriate form of compensatory mitigation, the District Engineer may waive or reduce the requirement to provide wetland compensatory mitigation for wetland impacts.

g. Compensatory mitigation proposals submitted with the " notification" may be either conceptual or detailed. If conceptual plans are approved under the verification, then the Corps will condition the verification to require detailed plans be submitted and approved by the Corps prior to construction of the authorized activity in waters of the US.

h. Permittees may propose the use of mitigation banks, in-lieu fee arrangements or separate activity-specific compensatory mitigation. In all cases that require compensatory mitigation, the mitigation provisions will specify the party responsible for accomplishing and/or complying with the mitigation plan.

20. Spawning Areas. Activities, including structures and work in navigable waters of the US or discharges of dredged or fill material, in spawning areas during spawning seasons must be avoided to the maximum extent practicable. Activities that result in the physical destruction (e.g., excavate, fill, or smother downstream by substantial turbidity) of an important spawning area are not authorized.

21. Management of Water Flows. To the maximum extent practicable, the activity must be designed to maintain preconstruction downstream flow conditions (e.g., location, capacity, and flow rates). Furthermore, the activity must not permanently restrict or impede the passage of normal or expected high flows (unless the primary purpose of the fill is to impound waters) and the structure or discharge of dredged or fill material must withstand expected high flows. The activity must, to the maximum extent practicable, provide for retaining excess flows from the site, provide for maintaining surface flow rates from the site similar to preconstruction conditions, and provide for not increasing water flows from the project site, relocating water, or redirecting water flow beyond preconstruction conditions. Stream channelizing will be reduced to the minimal amount necessary, and the activity must, to the maximum extent practicable, reduce adverse effects such as flooding or erosion downstream and upstream of the project site, unless the activity is part of a larger system designed to manage water flows. In most cases, it will not be a requirement to conduct detailed studies and monitoring of water flow.

This condition is only applicable to projects that have the potential to affect waterflows. While appropriate measures must be taken, it is not necessary to conduct detailed studies to identify such measures or require monitoring to ensure their effectiveness. Normally, the Corps will defer to state and local authorities regarding management of water flow.

22. Adverse Effects From Impoundments. If the activity creates an impoundment of water, adverse effects to the aquatic system due to the acceleration of the passage of water, and/or the restricting its flow shall be minimized to the maximum extent practicable. This includes

structures and work in navigable waters of the US, or discharges of dredged or fill material.

23. Waterfowl Breeding Areas. Activities, including structures and work in navigable waters of the US or discharges of dredged or fill material, into breeding areas for migratory waterfowl must be avoided to the maximum extent practicable.

24. Removal of Temporary Fills. Any temporary fills must be removed in their entirety and the affected areas returned to their preexisting elevation.

25. Designated Critical Resource Waters. Critical resource waters include, NOAA-designated marine sanctuaries, National Estuarine Research Reserves, National Wild and Scenic Rivers, critical habitat for Federally listed threatened and endangered species, coral reefs, state natural heritage sites, and outstanding national resource waters or other waters officially designated by a state as having particular environmental or ecological significance and identified by the District Engineer after notice and opportunity for public comment. The District Engineer may also designate additional critical resource waters after notice and opportunity for comment.

a. Except as noted below, discharges of dredged or fill material into waters of the US are not authorized by NWP 7, 12, 14, 16, 17, 21, 29, 31, 35, 39, 40, 42, 43, and 44 for any activity within, or directly affecting, critical resource waters, including wetlands adjacent to such waters. Discharges of dredged or fill materials into waters of the US may be authorized by the above NWP 7 in National Wild and Scenic Rivers if the activity complies with General Condition 7. Further, such discharges may be authorized in designated critical habitat for Federally listed threatened or endangered species if the activity complies with General Condition 11 and the USFWS or the NMFS has concurred in a determination of compliance with this condition.

b. For NWP 3, 8, 10, 13, 15, 18, 19, 22, 23, 25, 27, 28, 30, 33, 34, 36, 37, and 38, notification is required in accordance with General Condition 13, for any activity proposed in the designated critical resource waters including wetlands adjacent to those waters. The District Engineer may authorize activities under these NWP only after it is determined that the impacts to the critical resource waters will be no more than minimal.

26. Fills Within 100-Year Floodplains. For purposes of this General Condition, 100-year floodplains will be identified through the existing Federal Emergency Management Agency's (FEMA) Flood Insurance Rate Maps or FEMA-approved local floodplain maps.

a. Discharges in Floodplain; Below Headwaters. Discharges of dredged or fill material into waters of the US within the mapped 100-year floodplain, below headwaters (i.e. five cfs), resulting in permanent above-grade fills, are not authorized by NWP 39, 40, 42, 43, and 44.

b. Discharges in Floodway; Above Headwaters. Discharges of dredged or fill material into waters of the US within the FEMA or locally mapped floodway, resulting in permanent above-grade fills, are not authorized by NWP 39, 40, 42, and 44.

c. The permittee must comply with any applicable FEMA-approved state or local

floodplain management requirements.

27. Construction Period. For activities that have not been verified by the Corps and the project was commenced or under contract to commence by the expiration date of the NWP (or modification or revocation date), the work must be completed within 12-months after such date (including any modification that affects the project).

For activities that have been verified and the project was commenced or under contract to commence within the verification period, the work must be completed by the date determined by the Corps.

For projects that have been verified by the Corps, an extension of a Corps approved completion date maybe requested. This request must be submitted at least one month before the previously approved completion date.

### **FURTHER INFORMATION**

1. District Engineers have authority to determine if an activity complies with the terms and conditions of a NWP.
2. NWPs do not obviate the need to obtain other Federal, State, or local permits, approvals, or authorizations required by law.
3. NWPs do not grant any property rights or exclusive privileges.
4. NWPs do not authorize any injury to the property or rights of others.
5. NWPs do not authorize interference with any existing or proposed Federal project.

### **DEFINITIONS**

*Best Management Practices (BMPs):* BMPs are policies, practices, procedures, or structures implemented to mitigate the adverse environmental effects on surface water quality resulting from development. BMPs are categorized as structural or nonstructural. A BMP policy may affect the limits on a development.

*Compensatory Mitigation:* For purposes of Section 10/404, compensatory mitigation is the restoration, creation, enhancement, or in exceptional circumstances, preservation of wetlands and/or other aquatic resources for the purpose of compensating for unavoidable adverse impacts, which remain, after all appropriate and practicable avoidance and minimization has been achieved.

*Creation:* The establishment of a wetland or other aquatic resource where one did not formerly

exist.

Enhancement: Activities conducted in existing wetlands or other aquatic resources that increase one or more aquatic functions.

Ephemeral Stream: An ephemeral stream has *flowing* water only during and for a short duration after, precipitation events in a typical year. Ephemeral stream beds are located above the water table year-round. Groundwater is not a source of water for the stream. Runoff from rainfall is the primary source of water for stream flow.

Farm Tract: A unit of contiguous land under one ownership that is operated as a farm or part of a farm.

Flood Fringe: That portion of the 100-year floodplain outside of the floodway (often referred to as “floodway fringe”).

Floodway: The area regulated by Federal, state, or local requirements to provide for the discharge of the base flood so the cumulative increase in water surface elevation is no more than a designated amount (not to exceed one foot as set by the National Flood Insurance Program) within the 100-year floodplain.

Independent Utility: A test to determine what constitutes a single and complete project in the Corps regulatory program. A project is considered to have independent utility if it would be constructed absent the construction of other projects in the project area. Portions of a multi-phase project that depend upon other phases of the project do not have independent utility. Phases of a project that would be constructed even if the other phases were not built can be considered as separate single and complete projects with independent utility.

Intermittent Stream: An intermittent stream has flowing water during certain times of the year, when groundwater provides water for stream flow. During dry periods, intermittent streams may not have flowing water. Runoff from rainfall is a supplemental source of water for stream flow.

Loss of waters of the US: Waters of the US that include the filled area and other waters that are permanently adversely affected by flooding, excavation, or drainage because of the regulated activity. Permanent adverse effects include permanent above-grade, at-grade, or below-grade fills that change an aquatic area to dry land, increase the bottom elevation of a waterbody, or change the use of a waterbody. The acreage of loss of waters of the US is the threshold measurement of the impact to existing waters for determining whether a project may qualify for a NWP; it is not a net threshold that is calculated after considering compensatory mitigation that may be used to offset losses of aquatic functions and values. The loss of stream bed includes the linear feet of stream bed that is filled or excavated. Waters of the US temporarily filled, flooded, excavated, or drained, but restored to preconstruction contours and elevations after construction, are not included in the measurement of loss of waters of the US. Impacts to ephemeral waters are only not included in the acreage or linear foot measurements of loss of waters of the US or loss of stream bed, for the purpose of determining compliance with the threshold limits of the NWPs.

Non-tidal Wetland: An area that, during a year with normal patterns of precipitation has standing or flowing water for sufficient duration to establish an ordinary high water mark. Aquatic vegetation within the area of standing or flowing water is either non-emergent, sparse, or absent. Vegetated shallows are considered to be open waters. The term “open water” includes rivers, streams, lakes, and ponds. For the purposes of the NWPs, this term does not include ephemeral waters.

Perennial Stream: A perennial stream has flowing water year-round during a typical year. The water table is located above the stream bed for the most of the year. Groundwater is the primary source of water for stream flow. Runoff from rainfall is a supplemental source of water for stream flow.

Permanent Above-grade Fill: A discharge of dredged or fill material into waters of the US, including wetlands, that results in a substantial increase in ground elevation and permanently converts part or all of the waterbody to dry land. Structural fills authorized by NWPs 3, 25, 36, etc. are not included.

Preservation: The protection of ecologically important wetlands or other aquatic resources in perpetuity through the implementation of appropriate legal and physical mechanisms. Preservation may include protection of upland areas adjacent to wetlands as necessary to ensure protection and/or enhancement of the overall aquatic ecosystem.

Restoration: Re-establishment of wetland and/or other aquatic resource characteristics and function(s) at a site where they have ceased to exist, or exist in a substantially degraded state.

Riffle and Pool Complex: Riffle and pool complexes are special aquatic sites under the

404(b)(1) Guidelines. Riffle and pool complexes sometimes characterize steep gradient sections of streams. Such stream sections are recognizable by their hydraulic characteristics. The rapid movement of water over a coarse substrate in riffles results in a rough flow, a turbulent surface and high dissolved oxygen levels in the water. Pools are deeper areas associated with riffles. A slower stream velocity, a streaming flow, a smooth surface, and a finer substrate characterize pools.

*Single and Complete Project:* The term “single and complete project” is defined at 33 CFR 330.2(i) as the total project proposed or accomplished by one owner/developer or partnership or other association of owners/developers (see definition of independent utility). For linear projects, the “single and complete project” (i.e., a single and complete crossing) will apply to each crossing of a separate water of the US (i.e., a single waterbody) at that location. An exception is for linear projects crossing a single waterbody several times at separate and distant locations; each crossing is considered a single and complete project. However, individual channels in a braided stream or river, or individual arms of a large, irregularly shaped wetland or lake, etc., are not separate waterbodies.

*Stormwater Management:* Stormwater management is the mechanism for controlling stormwater runoff for the purposes of reducing downstream erosion, water quality degradation, and flooding and mitigating the adverse effects of changes in land use on the aquatic environment.

*Stormwater Management Facilities:* Stormwater management facilities are those facilities, including but not limited to, stormwater retention and detention ponds and BMPs, which retain water for a period of time to control runoff and/or improve the quality (i.e., by reducing the concentration of nutrients, sediments, hazardous substances and other pollutants) of stormwater runoff.

*Stream Channelization:* The manipulation of a stream channel to increase the rate of water flow through the stream channel. Manipulation may include deepening, widening, straightening, armoring, or other activities that change the stream cross-section or other aspects of stream channel geometry to increase the rate of water flow through the stream channel. A channelized stream remains a water of the US, despite the modifications to increase the rate of water flow.

*Tidal Wetland:* A tidal wetland is a wetland (i.e., water of the US) that is inundated by tidal waters. The definitions of a wetland and tidal waters can be found at 33 CFR 328.3(b) and 33 CFR 328.3(f), respectively. Tidal waters rise and fall in a predictable and measurable rhythm or cycle due to the gravitational pulls of the moon and sun. Tidal waters end where the rise and fall of the water surface can no longer be practically measured in a predictable rhythm due to masking by other waters, wind, or other effects. Tidal wetlands are located channelward of the high tide line (i.e., spring high tide line) and are inundated by tidal waters two times per lunar month, during spring high tides.

*Vegetated Buffer:* A vegetated upland or wetland area next to rivers, streams, lakes, or other open waters, which separates the open water from developed areas, including agricultural land. Vegetated buffers provide a variety of aquatic habitat functions and values (e.g., aquatic habitat

for fish and other aquatic organisms, moderation of water temperature changes, and detritus for aquatic food webs) and help improve or maintain local water quality. A vegetated buffer can be established by maintaining an existing vegetated area or planting native trees, shrubs, and herbaceous plants on land next to openwaters. Mowed lawns are not considered vegetated buffers because they provide little or no aquatic habitat functions and values. The establishment and maintenance of vegetated buffers is a method of compensatory mitigation that can be used in conjunction with the restoration, creation, enhancement or preservation of aquatic habitats to ensure that activities authorized by NWP result in minimal adverse effects to the aquatic environment. (See General Condition 19.)

Vegetated Shallows: Vegetated shallows are special aquatic sites under the 404(b)(1) Guidelines. They are areas that are permanently inundated and under normal circumstances have rooted aquatic vegetation, such as seagrasses in marine and estuarine systems and a variety of vascular rooted plants in freshwater systems.

Waterbody: A waterbody is any area that in a normal year has water flowing or standing above ground to the extent that evidence of an ordinary high water mark is established. Wetlands contiguous to the waterbody are considered part of the waterbody.

## **FINAL REGIONAL CONDITIONS FOR NATIONWIDE PERMITS IN THE WILMINGTON DISTRICT**

1. Waters Excluded from NWP or Subject to Additional Notification Requirements:
  - a. The Corps identified waters that will be excluded from use of this NWP. These waters are:
    1. Discharges into Waters of the United States designated by either the North Carolina Division of Marine Fisheries (NCDMF) or the North Carolina Wildlife Resources Commission (NCWRC) as anadromous fish spawning area are prohibited during the period between February 15 and June 30, without prior written approval from NCDMF or NCWRC and the Corps.
    2. Discharges into Waters of the United States designated as sturgeon spawning areas are prohibited during the period between February 1 and June 30, without prior written approval from the National Marine Fisheries Service (NMFS).
  - b. The Corps identified waters that will be subject to additional notification requirements for activities authorized by this NWP. These waters are:
    1. Prior to the use of any NWP in any of the following North Carolina *designated waters*, applicants must comply with Nationwide Permit General Condition 13. In addition, the applicant must furnish a written statement of compliance with all of the conditions of the applicable Nationwide Permit. The North Carolina *designated waters* that require additional notification requirements are “Outstanding Resource Waters” (ORW) and “High Quality



Waters” (HQW) (as defined by the North Carolina Division of Water Quality), or “Inland Primary Nursery Areas” (IPNA) (as defined by the North Carolina Wildlife Resources Commission), or contiguous wetlands (as defined by the North Carolina Division of Water Quality), or “Primary Nursery Areas” (PNA) (as defined by the North Carolina Division of Marine Fisheries).

2. Applicants for any NWP in a designated “Area of Environmental Concern” (AEC) in the twenty (20) coastal counties of Eastern North Carolina covered by the North Carolina Coastal Area Management Act (CAMA), must also obtain the required CAMA permit. Construction activities may not commence until a copy of the approved CAMA permit is furnished to the appropriate Wilmington District Regulatory Field Office (Wilmington Field Office – P.O. Box 1890, Wilmington, NC 28402 or Washington Field Office – P.O. Box 1000, Washington, NC 27889) for authorization to begin work.

3. Prior to the use of any NWP on a Barrier Island of North Carolina, applicants must comply with Nationwide Permit General Condition 13. In addition, the applicant shall furnish a written statement of compliance with all of the conditions listed of the applicable Nationwide Permit.

4. Prior to the use of any NWP in a “Mountain or Piedmont Bog” of North Carolina, applicants shall comply with Nationwide Permit General Condition 13. In addition, the applicant shall furnish a written statement of compliance with all of the conditions listed of the applicable NWP.

Note: The following wetland community types identified in the N.C. Natural Heritage Program document, “Classification of Natural communities of North Carolina (Michael P. Schafale and Alan S. Weakley, 1990), are subject to this regional condition.

Mountain Bogs

Swamp Forest-Bog Complex  
Swamp Forest-Bog Complex (Spruce Subtype)  
Southern Appalachian Bog (Northern Subtype)  
Southern Appalachian Bog (Southern Subtype)  
Southern Appalachian Fen

Piedmont Bogs

Upland Depression Swamp Forest

5. Prior to the use of any NWP in Mountain Trout Waters within twenty-five (25) designated counties of North Carolina, applicants shall comply with Nationwide General Condition 13. In addition, the applicant shall furnish a written statement of compliance with all of the conditions listed of the applicable NWP. Notification will include a letter of comments and recommendations from the North Carolina Wildlife Resources Commission (NCWRC), the

location of work, a delineation of wetlands, a discussion of alternatives to working in the Mountain Trout Waters, why other alternatives were not selected, and a plan to provide compensatory mitigation for all unavoidable adverse impacts to the Mountain Trout Waters. To facilitate coordination with the NCWRC, the proponent may provide a copy of the notification to the NCWRC concurrent with the notification to the District Engineer. The NCWRC will respond both to the proponent and directly to the Corps of Engineers.

The twenty-five (25) designated counties are:

Alleghany	Ashe	Avery	Yancey
Buncombe	Burke	Caldwell	Wilkes
Cherokee	Clay	Graham	Swain
Haywood	Henderson	Jackson	Surry
Macon	Madison	McDowell	Stokes
Mitchell	Polk	Rutherford	
Transylvania	Watauga		

6. Applicants shall notify the NCDENR Shellfish Sanitation Section prior to dredging in or removing sediment from an area closed to shell fishing where the effluent may be released to an area open for shell fishing or swimming in order to avoid contamination of the disposal area and allow a temporary shellfish closure to be made. Any disposal of sand to the beach should occur between November 1 and April 30 when recreational usage is low. Only clean sand should be used and no dredged sand from closed shell fishing areas. If beach disposal was to occur at times other than stated above or if sand from a closed shell fishing area is to be used, a swim advisory shall be posted and a press release shall be made. NCDENR Shellfish Sanitation Section must be notified before commencing this activity.

## 2. List of Final Corps Regional Modifications and Conditions for All Nationwide Permits

a. Individual or multiple NWP may not be used for activities that result in the cumulative loss or degradation of greater than 300 total linear feet of perennial streambed or intermittent streambed that exhibits important aquatic function(s).

b. Prior to the use of any NWP (except 13, 27, and 39) for any activity that has more than a total of 150 total linear feet of perennial streambed impacts or intermittent streambed impacts (if the intermittent stream has important aquatic function), the applicant must comply with Nationwide Permit General Condition 13. In addition, the applicant shall furnish a written statement of compliance with all of the conditions listed of the applicable NWP. Compensatory mitigation is typically required for any impact that requires such notification. [Note: The Corps uses the Intermittent Channel Evaluation Form, located with Permit Information on the Regulatory Program Web Site, to aid in the determination of the intermittent channel stream status. Also, NWPs 13, 27 and 39 have specific reporting requirements.]

c. For all Nationwide Permits which allow the use of concrete as a building material, measures will be taken to prevent live or fresh concrete, including bags of uncured concrete, from coming into contact with waters of the state until the concrete has hardened.

d. For all Nationwide Permits that allow for the use of riprap material for bank stabilization, filter cloth must be placed underneath the riprap as an additional requirement of its use in North Carolina waters.

e. For all NWPs that involve the construction of culverts, measures will be included in the construction that will promote the safe passage of fish and other aquatic organisms. All culverts in the 20 CAMA coastal counties must be buried to a depth of one foot below the

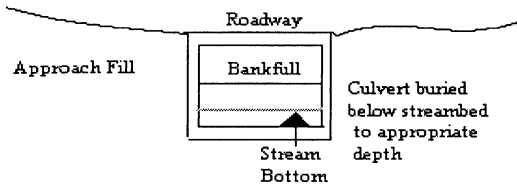

bed of the stream or wetland. For all culvert construction activities, the dimension, pattern, and profile of the stream, (above and below a pipe or culvert), should not be modified by widening the stream channel or by reducing the depth of the stream. Culvert inverts will be buried at least one foot below the bed of the stream for culverts greater than 48 inches in diameter. For culverts 48 inches in diameter or smaller, culverts must be buried below the bed of the stream to a depth equal to or greater than 20 percent of the diameter of the culvert. Bottomless arch culverts will satisfy this condition. A waiver from the depth specifications in this Regional Condition may be requested in writing. The waiver will only be issued if it can be demonstrated that the impacts of complying with this Regional Condition would result in more adverse impacts to the aquatic environment.

**NORTH CAROLINA DIVISION OF WATER QUALITY**  
**GENERAL CERTIFICATION CONDITIONS**  
**GC3361**

1. Proposed fill or substantial modification of wetlands or waters (including streams) under this General Certification requires notification to the Division of Water Quality. Two copies shall be submitted to DWQ at the time of notification in accordance with 15A NCAC 2H .0501(a). Written concurrence from DWQ is not required unless any standard conditions of this Certification cannot be met;

2. Appropriate sediment and erosion control practices which equal or exceed those outlined in the most recent version of the "North Carolina Sediment and Erosion Control Planning and Design Manual" or the "North Carolina Surface Mining Manual" whichever is more appropriate (available from the Division of Land Resources (DLR) in the DENR Regional or Central Offices) shall be in full compliance with all specifications governing the proper design, installation and operation and maintenance of such Best Management Practices in order to assure compliance with the appropriate turbidity water quality standard;

3. In accordance with 15A NCAC 2H .0506 (h) compensatory mitigation may be required for impacts to 150 linear feet or more of streams and/or one acre or more of wetlands. In addition, buffer mitigation may be required for any project with Buffer Rules in effect at the time of application for buffer impacts resulting from activities classified as "allowable with mitigation" within the "Table of Uses" section of the Buffer Rules or require a variance under the Buffer Rules. A determination of buffer, wetland and stream mitigation requirements shall be made for any Certification for this Nationwide Permit. The most current design and monitoring protocols from DWQ shall be followed and written plans submitted for DWQ approval as required in those protocols. When compensatory mitigation is required for a project, the mitigation plans must be approved by DWQ in writing before the impacts approved by the Certification occur. The mitigation plan must be implemented and/or constructed before any permanent building or structure on site is occupied. In the case of public road projects, the mitigation plan must be implemented before the road is opened to the traveling public;
4. Compensatory stream mitigation shall be required at a 1:1 ratio for all perennial and intermittent stream impacts equal to or exceeding 150 feet and that require application to DWQ in watersheds classified as ORW, HQW, Tr, WS-I and WS-II;
5. All sediment and erosion control measures placed in wetlands or waters shall be removed and the original grade restored within two months after the Division of Land Resources has released the project;
6. Measures shall be taken to prevent live or fresh concrete from coming into contact with waters of the state until the concrete has hardened;
7. In accordance with North Carolina General Statute Section 143-215.3D(e), any request for written concurrence for a 401 Water Quality Certification must include the appropriate fee. If a project also requires a CAMA Permit, one payment to both agencies shall be submitted and will be the higher of the two fees;
8. Impacts to any stream length in the Neuse, Tar-Pamlico, Randleman and Catawba River Basins (or any other river basins with Riparian Area Protection Rules [Buffer Rules] in effect at the time of application) requires written concurrence from DWQ in accordance with 15A NCAC 2B.0200. Activities listed as "exempt" from these rules do not need to apply for written concurrence under this Certification. New development activities located in the protected 50-foot wide riparian areas (whether jurisdictional wetlands or not) within the Neuse, Tar-Pamlico, Randleman and Catawba River Basins shall be limited to "uses" identified within and constructed in accordance with 15A NCAC 2B .0200. All new development shall be located, designed, constructed, and maintained to have minimal disturbance to protect water quality to the maximum extent practicable through the use of best management practices;
9. Additional site-specific conditions may be added to projects for which written concurrence is required or requested under this Certification in order to ensure compliance with all applicable water quality and effluent standards;

10. Concurrence from DWQ that this Certification applies to an individual project shall expire three years from the date of the cover letter from DWQ or on the same day as the expiration date of the corresponding Nationwide and Regional General Permits, whichever is sooner;

11. When written concurrence is required, the applicant is required to use the most recent version of the Certification of Completion form to notify DWQ when all work included in the 401 Certification has been completed.

**NORTH CAROLINA DIVISION OF COASTAL MANAGEMENT**  
**STATE CONSISTENCY**

Consistent.

Citations:

2002 Nationwide Permits - Federal Register Notice 15 Jan 2002

2002 Nationwide Permits Corrections - Federal Register Notice 13 Feb 2002

2002 Regional Conditions – Authorized 17 May 2002

