



STATE OF NORTH CAROLINA
DEPARTMENT OF TRANSPORTATION

MICHAEL F. EASLEY
GOVERNOR

LYNDO TIPPETT
SECRETARY

January 9, 2007

MEMORANDUM TO: Mr. Jay Swain, Jr., PE
Division 13 Engineer

FROM: Philip S. Harris, III, P.E., Unit Head *E. J. Lusk*
Natural Environment Unit *for*
Project Development and Environmental Analysis Branch

SUBJECT: Yancey & Mitchell Counties, Replace Bridge No. 143 on
SR 1304 over The North Toe River; T.I.P. Number B-2848;
Federal Aid Project BRZ-1304(4); State Project 8.2880401

Attached is the U. S. Army Corps of Engineers 404 Nationwide Permit Numbers 23 & 33 and the general conditions for the 401 Water Quality Certification for the above referenced project. All environmental permits have been received for the construction of this project.

PSH/gyb

Attachment

Cc:

Mr. Majed Alghandour, P. E., Programming and TIP
Mr. Jay Bennett, P.E., Roadway Design
Dr. David Chang, P.E., Hydraulics
Mr. Randy Garris, P.E. State Contract Officer
Mr. Art McMillan, P.E., Highway Design
Mr. Greg Perfetti, P.E., Structure Design
Mr. Mark Staley, Roadside Environmental
Mr. John F. Sullivan, FHWA
Ms. Teresa Hart, P.E., PDEA Western Region Unit Head
Mr. Harold Draper, TVA

PROJECT COMMITMENTS

Mitchell & Yancey Counties
Bridge No. 143 on SR 1304 over the North Toe River
Federal-aid Project No. BRZ-1304(4),
State Project No. 8.2880401
WBS 32728.1.1
T.I.P. No. B-2848

In addition to the Nationwide Permit 23 and 33 Conditions, the General Nationwide Permit Conditions, Section 404 Only Conditions, Regional Conditions, State Consistency Conditions, NCDOT's Guidelines for Best Management Practices for Bridge Demolition and Removal, Design Standards in Sensitive Watersheds, NCDOT's Best Management Practices for Protection of Surface Waters, General Certification Conditions, and Section 401 Conditions of Certification, the following special commitments have been agreed to by NCDOT:

COMMITMENTS DEVELOPED THROUGH PROJECT DEVELOPMENT

Highway Division 13, Hydraulics Unit, Structure Design Unit

In order to avoid and minimize environmental impacts associated with the replacement of Bridge No. 143, all standard procedures and measures, including NCDOT's Best Management Practices for Protection of Surface Waters and the Tennessee Valley Authority's (TVA) Water Management Standard Conditions will be strictly enforced during the construction stage of the project. Provisions to preclude contamination by toxic substances during the construction interval will also be strictly enforced.

1. In addition to NC DOT Best Management Practices, the contractor must submit a bridge demolition plan for approval by the Resident Engineer and the Bridge Construction Engineer prior to beginning bridge removal. Since some bridge debris may enter the water, the contractor must submit a work plan sealed by a PE registered in North Carolina and that *follows the guidelines provided in the Plan for Removal of Existing Structures that is included in the Biological Assessment for this project, attached to this Consultation*. The contractor's work plan will detail the maximum amount of the bridge that can be safely removed dropping minimal portions into the water. Also, this plan will not allow the use of explosives and will detail the methods to be used to retrieve and dispose of any components of the existing bridge dropped into the water. The volume of structural material to be retrieved from the existing bridge will be approximately 150 cubic yards (114.61 cubic meters).
2. Construction will be accomplished so wet concrete does not contact water entering or flowing in the river. Demolition of the existing structure will be completed such that minimal debris from the existing deck enters the river. Any debris or construction material that falls into the river will be removed immediately.
3. No deck drainage will be allowed to enter into the water, and every effort will be made to minimize the overall footprint of bents, any scour problems, and any debris accumulation associated with the project.

Roadway Design Unit, Project Development and Environmental Analysis Branch, Roadside Environmental Unit, Highway Division 13, Structure Design Unit

1. Upon completion of the project the existing approach fill will be removed to natural grade and the area will be planted with native grasses and tree species such as Bluegrass or as recommended by Roadside Environmental landscape plans. Should the contract for such plantings expire during the summer, landscaping should extend into the planting season, which continues through December.
2. Activities in the flood plain will be limited to those needed to construct the proposed bridge and remove the existing bridge. Areas used for borrow or construction by-products will not be located in floodplains.
3. Work pads in the flood plain will be minimized.

Highway Division 13, Hydraulics, PD&EA, Structure Design Unit

1. NCDOT will coordinate with the U.S. Fish and Wildlife Service to incorporate sufficient measures and monitoring, as required, in addition to those listed below, to avoid impacts to the endangered Appalachian Elktoe mussel (*Alasmidonta raveneliana*).
2. All Elktoe mussel species found during the relocation may be removed prior to construction with approval from the US Fish and Wildlife Service. In water construction may be subject to a moratorium. A Consultation in compliance with **Section (7a)** of the Endangered Species Act of 1973 will be completed and reviewed according to US Fish and Wildlife policy prior to beginning construction activities.
3. The NCDOT Project Development and Environmental Analysis Branch and the U.S. Fish and Wildlife Service will be invited to the pre-construction conference to discuss with the contractor the provisions of the Endangered Species Act of 1973 and penalties for violation of the Act.
4. Stringent erosion control measures included in the Division of Water Quality's High Quality Waters Erosion Control Guidelines will be implemented during all construction activities.
5. Riparian vegetation will be maintained wherever possible, especially large trees.
6. If riparian areas are disturbed, they will be revegetated with native species as soon as possible after construction.
7. Prior to construction the contractor will be required to give notification of the construction initiation date to the U.S. Fish and Wildlife Service, N.C. Wildlife Resources Commission, and the Tennessee Valley Authority.
8. Pre-let surveys will be performed at the bridge for occurrence of the Appalachian Elktoe (*Alasmidonta raveneliana*).
9. The North Toe River contains a significant small mouth bass fishery in the area of the project; North Carolina regulations entitled Design Standards in Sensitive Watersheds shall be implemented during the design and construction of this project, as applicable. A letter of notification, with reference to impacts to small mouth bass water habitat, will be provided to

the U.S. Army Corps of Engineers - Asheville Regulatory Field Office and the N.C. Wildlife Resources Commission (WRC) office prior to construction of the project. An in water work moratorium will be enforced from May 1st to June 1st in order to protect this small mouth bass fishery.

10. Due to the presence of the migratory birds in the vicinity of the existing bridge, construction should be planned to occur after the nesting season. Alternatively, netting to prevent swallows from nesting prior to the beginning of construction activities may be utilized in accordance with the Migratory Bird Treaty Act and after PDEA/ONE coordination with the US Fish and Wildlife Service.
11. The NCDOT will provide or contract with biologists with experience in mussel relocation techniques to remove Appalachian elktoe from the impact site and relocate them to the approved relocation site on the North Toe River between Penland and Boonford at about River Mile 25.5, according to the procedures on the approved relocation plan within the BA. The plan details appropriate collection methods, tagging and recapture, handling and transportation of individuals, and monitoring protocols, which includes the monitoring of the relocation sites for recovery, survival (of recovered mussels) movement and growth of mussels for a period of 5 years.
12. The NCDOT shall monitor the river channel and banks at sites upstream, at the construction sites and downstream to determine changes in habitat resulting from activities at these sites. If any problems with regards to stream stability are detected during the monitoring, the NCDOT will attempt to correct the problems.
13. NCDOT will protect and/or restore 100 foot riparian buffers for at least 3,000 linear feet of stream within the action area.
14. NCDOT will ensure that contractor understands and follows the measures listed in the section of the greensheets, and included in the Biological Opinion issued for the project by the (US Fish and Wildlife) Service.
15. Containment systems shall be developed for particular stages of the demolition and construction of the bridges to minimize impacts to the Appalachian elktoe and its habitat.
16. Demolition activities and the relocation of mussels will be conducted during time periods that reduce impacts to the Appalachian elktoe.
17. The NCDOT will send the Service, Asheville field office, copies of the monitoring reports for the relocated mussels every year for the 5 year monitoring time period.
18. During the relocation of mussels the Service may alter, if needed methods and plans for moving mussels.
19. The NCDOT will notify the Service if their monitoring of the river channel and river banks reveals changes in habitat resulting from project activities.
20. All appropriate NCDOT BMP's for bridge maintenance, construction, and demolition will be followed or exceeded for these projects and any additional BMP's listed in these greensheets shall be followed.

21. A Service biologist will be notified of and present at the preconstruction meeting to cover permit conditions and discuss any questions the contractor has regarding implementation of this project. After the contractor submits plans for various stages of the projects a Service biologist will review and provide comments on the plans, as well as, attend any meetings to discuss implementation of the plans.
22. The NCDOT will ensure that a qualified aquatic biologist is present at critical times to monitor certain phases of construction, including but not limited to, initial clearing for construction, at the time causeways are installed, when demolition begins, and when causeways are removed. The individual will be present to ensure that the procedures listed in the "Conservation Measures" section of the US FWS Biological Opinion, the reasonable and prudent measures, and terms and conditions are being implemented and that all project plans are being implemented in a manner to ensure that the conditions of the Biological Opinion are met.
23. Due to the severely deteriorated condition of the bridge decks, a containment system shall be installed prior to the removal of the concrete deck for bridge B-2848. This system may be supported from the existing girders or substructure (such as tarps) or could be independent of the existing bridge, such as floating devices that catch any debris that may fall during deck removal. The containment system will only be used to catch debris that inadvertently falls due to the condition of the deck.
24. A containment system shall be developed and installed prior to the removal of the piers. The conservation measures proposed by the NCDOT recommend placing turbidity curtains, if the water depth is sufficient, around each of the bents. The USFWS recommends that the design include a system that uses a containment system such as Jersey barriers around each bent.
25. When constructing the drilled shafts a containment system will be developed so that material does not enter the river. Any material by-product will be pumped out of the shaft and onto uplands and to an off-site disposal area or will be treated through a proper stilling basin or silt bag.
26. The NCDOT will not relocate mussels between May 1 and June 30, the time at which the Appalachian elktoe are releasing glochidia. The NCDOT will relocate the mussels during low flow, low turbidity, and relatively cool weather, the most appropriate time to accomplish these factors will be the fall.
27. Bridge demolition will occur during low flow (typically late summer) to reduce the likelihood that sediment will leave the project area and potentially impact downstream resources.
28. NCDOT proposed in the BA to relocate all native mussels, including the Appalachian elktoe, from the project footprints, extending downstream 80 meters and upstream 20 meters of the two bridge replacements. Representatives of the Service, Asheville field office, may determine during the relocation of the mussels to reduce the area that the mussels are moved from.
29. A Service biologist will review and provide comments on plans proposed to correct problems that may be revealed in the monitoring of the river channel and banks within the project area.
30. The erosion control plan will be in place prior to any ground disturbance.

31. Any work pads that must be placed within the floodplain to complete the project construction will be constructed by placing down fabric matting prior to placing the stone work pad. All of the stone and matting will be removed and disposed off-site after project completion.
32. Unconsolidated material will not be placed on the causeways given that the material could be washed off of the causeways or settle into the causeways and enter the river. If unconsolidated material must be placed on the causeways, a solid barrier will be placed on the causeway prior to the placement of the material. The barrier and unconsolidated material will be removed at the end of each work day or anytime through out a work day that the water level rises to a point that could wash the material off of the causeway. Any consolidated material or equipment that is placed on the causeways will also be removed at the end of each work day or anytime through out a work day that he water level rises to a point where the material or equipment could be flooded.
33. All construction equipment should be refueled outside the 100 year floodplain or at least 200 feet from all water bodies (whichever distance is greater) and be protected with secondary containment. Hazardous materials, fuel, lubricating oils, or other chemicals will be stored outside the 100 year floodplain or at least 200 feet from all water bodies (whichever distance is greater), preferably at an upland site. Areas used for borrow or construction by-products will notbe located in wetlands or the 100-year floodplain.
34. Where opportunities exist, NCDOT will work with landowners, the general public, and other agencies to promote education and information about the Appalachian elktoe and their conservation.
35. NCDOT will pursue additional buffers and conservation opportunities along the main stem of the Cane River, North Toe River and Toe Rivers tributaries, either individually or in concert with other conservation programs.
36. NCDOT will explore opportunities to work with local and state water quality officials in order to minimize or eliminate wastewater and storm-water discharges into the Cane River, North Toe River and Toe Rivers.
37. NCDOT will consult with the US FWS on projects affecting aquatic habitat in the Toe River drainage, regardless of funding source, to ensure compliance with all provisions of the Act.
38. NCDOT will notify the USFWS of the implementation of any of the above stated conservation recommendations.

COMMITMENTS DEVELOPED THROUGH PERMITTING

Division 13 Construction, NEU, and REU

1. All work must be performed in strict compliance with the plans received by this office, which is a part of this permit. Any modification to the permit plans must be approved by the USACE prior to implementation.
2. Failure to institute and carry out the details of these special conditions will result in a directive to cease all ongoing and permitted work within waters and/or wetlands associated with the permitted project, or such other remedies and/or fines as the District Engineer or his authorized representatives may seek.

3. The permittee shall require its contractors and/or agents to comply with the terms and conditions of this permit in the construction and maintenance of this project, and shall provide each of its contractors and/or agents associated with the construction or maintenance of this project with a copy of this permit, and any authorized modifications. A copy of this permit, and any authorized modifications, including all conditions, shall be available at the project site during construction and maintenance of this project.
4. This permit does not authorize temporary placement or double handling of excavated or fill material within waters or wetlands outside the permitted area.
5. All Conditions of the attached North Carolina Wildlife Resources Commission letter of October 13, 2006 are hereby incorporated as special condition of this permit.
6. The permittee will report any violation of these conditions or violations of Section 2020 Clean Water Act or Section 10 of the Rivers and Harbors Act in writing to the Wilmington District, U.S. Army Corps of Engineers, within 24 hours of the permittee's discovery of the violation.
7. All Reasonable and Prudent Measures and Terms and Conditions contained in the July 6, 2006 US Fish and Wildlife Service's Biological Opinion on the effects of the subject bridge demolition and replacement on the federally endangered Appalachian elktoe and its Designated Critical Habitat are hereby incorporated as conditions of this permit. Your authorization under this Corps permit is conditional upon your compliance with all of the mandatory Reasonable and Prudent Measures and Terms and Conditions in the Biological Opinion.

Reasonable and Prudent Measures from USFWS Biological Opinion

1. The NCDOT will ensure that the contractor understands and follows the measures listed in the "Conservation Measures," "Reasonable and Prudent Measures," and "Terms and Conditions" sections of this Opinion.
2. Containment systems will be developed for particular stages of the demolition and construction of the bridges to minimize impacts to the Appalachian elktoe and its habitat.
3. Demolition activities and the relocation of mussels will be conducted during time periods that will result in fewer impacts to the Appalachian elktoe.
4. The NCDOT will send copies of the monitoring reports for the relocated mussels to the Service's Asheville Field Office every year for the 5-year monitoring time period.
5. During the relocation of mussels, the Service may alter, if needed, methods and plans for moving the mussels.
6. The NCDOT will notify the Service if their monitoring of the river channel and riverbanks reveals changes in habitat resulting from project activities.
7. All appropriate NCDOT BMP for bridge maintenance, construction, and demolition will be followed or exceeded for these projects, and any additional BMP listed in the "Terms and Conditions" section of this Opinion will be followed.

Terms and Conditions from USFWS Biological Opinion

1. A Service biologist will be present at the pre-construction meeting to cover permit conditions and discuss any questions the contractor has regarding implementation of these projects. After the contractor submits plans for various stages of the project, a Service biologist will review and provide comments on the plans and will attend any meetings to discuss implementation of the plans.
2. The NCDOT will ensure that a qualified aquatic biologist is present at critical times to monitor certain phases of construction, including, but not limited to, initial clearing for construction, when the causeways are installed, when demolition begins, and when the causeways are removed. The individual will be present to ensure that the procedures listed in the "Conservation Measures," "Reasonable and Prudent Measures," and "Terms and Conditions" sections of the Biological Opinion are being implemented and that all project plans are being implemented in a manner to ensure that the conditions of the Opinion are met.
3. A containment system shall be developed and installed prior to the removal of the piers. The conservation measures proposed by the NCDOT recommend placing turbidity curtains, if the water depth is sufficient, around each of the bents. We are concerned that turbidity curtains will not be of sufficient strength to capture material that may enter the river; therefore, we recommend that the design include a containment system such as the Jersey barriers (with fabric) around each bent.
4. When constructing the drilled shafts a containment system will be developed so that material does not enter the river. Any material by-product will be pumped out of the shaft and onto uplands and to an off-site disposal area or will be treated through a proper stilling basin or silt bag.
5. The conservation measures proposed by the NCDOT state that the saw slurry used during the demolition process will be contained by approved vacuum methods. Given that a wet saw will be used, the vacuum methods should include a provision for pumping and treating the saw slurry outside the project area.
6. The NCDOT will not relocate mussels between May 1 and June 30, the time at which Appalachian elktoes release glochidia. The NCDOT will relocate the mussels during low flow, low turbidity, and relatively cool weather; the most appropriate time to accomplish this would be in the fall.
7. Demolition of the bridge substructure will occur during low flow in order to reduce the likelihood that sediment will leave the project area and potentially impact downstream resources.
8. In the BA, the NCDOT proposed to relocate all native mussels, including the Appalachian elktoe, from the project "footprints," extending downstream 262 ft (80 m) and upstream 66 ft (20 m) of the two bridge replacements. Representatives of the Service's Asheville Field Office may determine during relocation of the mussels that the area the mussels are moved from should be reduced.
9. A Service biologist will review and provide comments on plans proposed to correct problems that may be revealed in the monitoring of the river channel and banks within the project area.

10. The erosion-control plan will be in place prior to any ground disturbance. When needed, combinations of erosion-control measures (such as silt bags in combination with a stilling basin) will be used to ensure that the most protective measures are being implemented.
11. Activities in the floodplain will be limited to those needed to construct the proposed bridge and remove the existing bridge.
12. Work pads will be used when equipment must be staged in the floodplain to complete the project construction. The work pads will be constructed by placing fabric matting down prior to placing the stone work pad. All of the stone and matting will be removed and disposed of off-site or the stone can be used in areas that require permanent stone protection after project completion.
13. Access roads and construction staging areas will be minimized to the maximum extent practicable. The access roads and construction staging areas should be established from the start of the project and designed with erosion-control measures. The placement of the access roads and staging areas will be discussed with the Service and determined at the pre-construction meetings.
14. Riparian vegetation, especially large trees, will be maintained wherever possible. If riparian areas are disturbed, they will be re-vegetated with native species as soon as possible after construction.
15. Upon completion of the project the existing approach fills will be removed to natural grade, and the area will be planted with native grasses and tree species.
16. Construction will be accomplished in a manner that prevents wet concrete from coming into contact with water entering or flowing in the river.
17. Unconsolidated material (such as sand and dirt) will not be placed directly on the causeways since the material could be washed off of the causeways or settle into the causeways and enter the river. If unconsolidated material must be placed on the causeways, a solid barrier will be placed on the causeways prior to the placement of the material. The barrier and unconsolidated material will be removed anytime throughout a work day when the water level rises to a point, or is expected to rise over night to a point, where material could wash off the causeway or during periods of inactivity (two or more consecutive days). Any equipment that is placed on the causeways will also be removed anytime throughout a work day when the water level rises to a point, or is expected to rise over night to a point, where the equipment could be flooded or during periods of inactivity (two or more consecutive days). The only exception to this measure is that the drill rig may be left in place for periods of inactivity; however, it must also be removed if the water rises or is expected to rise to a point where the drill rig could be flooded.
18. All construction equipment should be refueled outside the 100-year floodplain or at least 200 ft from all water bodies (whichever distance is greater) and be protected with secondary containment. During crucial periods of construction and demolition when the drill rig and crane cannot be moved, the drill rig and crane can be refueled while inside the 100-year floodplain provided that spill response materials (such as spill blankets and fueling diapers) are used during the refueling. Hazardous materials, fuel, lubricating oils, or other chemicals will be stored outside the 100-year floodplain or at least 200 ft from all water bodies

(whichever distance is greater), preferably at an upland site. Areas used for borrow or construction by-products will not be located in wetlands or the 100-year floodplain.

Conditions from NCWRC letter dated November 27, 2006

1. Sediment and erosion control measures should, at a minimum, adhere to the design standards for sensitive watersheds and be strictly maintained until project completion to avoid impacts to downstream aquatic resources.
2. Temporary or permanent herbaceous vegetation should be planted on all bare soil as soon as possible and within 10 calendar days of ground disturbing activities to provide long-term erosion control.
3. Tall fescue should not be used in riparian areas. We encourage NCDOT to utilize onsite vegetation and materials for riverbank stabilization when practicable. Erosion control matting should be used in riparian areas, instead of straw mulch and well anchored with 12" staples or 12" wooden survey stakes.
4. Only clean, sediment-free rock should be used as temporary fill (causeways), and should be removed without excessive disturbance of the natural stream bottom when construction is completed.
5. Discharge of materials into the river from demolition of the old bridge should be avoided as much as practicable. Any materials that inadvertently reach the water should be removed.
6. The natural dimension, pattern, and profile of the river above and below the crossing should not be modified by widening the channel or changing the depth of the river.
7. Removal of vegetation in riparian areas should be minimized. Native trees and shrubs should be planted along the banks to reestablish the riparian zone and to provide long-term erosion control.
8. Grading and backfilling should be minimized, and tree and shrub growth should be retained if possible to ensure long term availability of shoreline cover for fish and wildlife. Backfill materials should be obtained from upland sites.
9. Riprap placed for bank stabilization should be limited to the riverbank below the high water mark, and vegetation should be used for stabilization above the high water elevation.
10. Stormwater, including deck drainage, should be directed to buffer areas or retention basins and should not be routed directly into the river.
11. If concrete will be used during construction, work must be accomplished so that wet (uncured) concrete does not contact surface waters. This will lessen the chance of altering the water chemistry and causing a fish kill.
12. Discharging hydroseeding mixtures and washing out hydroseeders and other equipment in or adjacent to surface waters is strictly prohibited.
13. Heavy equipment should be operated from the bank rather than in the river channel whenever possible in order to minimize sedimentation and reduce the likelihood of introducing other

pollutants into the stream. All mechanized equipment operated near surface waters should be inspected and maintained regularly to prevent contamination of surface waters from fuels, lubricants, hydraulic fluids or other toxic materials.

14. The existing roadway that is to be eliminated should be removed back to original ground elevations and the natural floodplain elevations and functions should be restored. Disturbed areas should be seeded or mulched to stabilize the soil and native tree species should be planted with a spacing of not more than 10'x10'.

U.S. ARMY CORPS OF ENGINEERS
WILMINGTON DISTRICT

Action ID: SAW-2006-41203-300
USGS Quad: Huntdale

County: Mitchell and Yancey

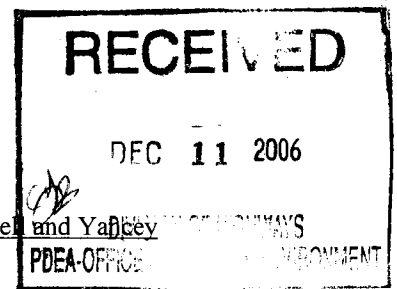

GENERAL PERMIT (REGIONAL AND NATIONWIDE) VERIFICATION

Property Owner / Authorized Agent: NCDOT, Gregory J. Thorpe, Ph.D, Environmental Management Director
Address: 1598 Mail Service Center
Raleigh, NC 27699-1598
Telephone No.: 919-733-3141

Size and location of property (water body, road name/number, town, etc.): Bridge Number 143 on SR 1304 (Tipton Hill Road/Ray Road) over the North Toe River near Burnsville in Mitchell and Yancey Counties, NC. (TIP B-2848).

Description of projects area and activity: to replace Bridge No. 143 on SR 1304 over the North Toe River. The new bridge will be on new alignment northwest, approximately 50-feet downstream, of the existing bridge. Temporary rock causeways, using pipes to maintain the linear flow of the river, will be required for the new bridge construction and for the demolition of the old bridge. One new pier will be located within the river channel to support the new structure. The project will result in less than 0.01 acre of permanent impact and 0.35 acre of temporary impacts to the North Toe River.

Applicable Law: Section 404 (Clean Water Act, 33 USC 1344)
 Section 10 (Rivers and Harbors Act, 33 USC 403)
Authorization: Regional General Permit Number:
Nationwide Permit Number: 23 and 33

Special Conditions

1. All work must be performed in strict compliance with the plans received by this office on , which are a part of this permit. Any modification to the permit plans must be approved by the USACE prior to implementation
2. Failure to institute and carry out the details of these special conditions will result in a directive to cease all ongoing and permitted work within waters and/or wetlands associated with the permitted project, or such other remedies and/or fines as the District Engineer or his authorized representatives may seek.
3. The permittee shall require its contractors and/or agents to comply with the terms and conditions of this permit in the construction and maintenance of this project, and shall provide each of its contractors and/or agents associated with the construction or maintenance of this project with a copy of this permit, and any authorized modifications. A copy of this permit, and any authorized modifications, including all conditions, shall be available at the project site during construction and maintenance of this project.
4. This permit does not authorize temporary placement or double handling of excavated or fill material within waters or wetlands outside the permitted area.
5. All conditions of the attached North Carolina Wildlife Resources Commission letter of November 27, 2006 are hereby incorporated as special conditions of this permit.
6. The permittee will report any violation of these conditions or violations of Section 404 of the Clean Water Act or Section 10 of the Rivers and Harbors Act in writing to the Wilmington District, U. S Army Corps of Engineers, within 24 hours of the permittee's discovery of the violation.
7. All Reasonable and Prudent Measures and Terms and Conditions contained in the July 6, 2006 US Fish and Wildlife Service's Biological Opinion on the effects of the subject bridge demolition and replacement on the federally endangered Appalachian elktoe and it's Designated Critical Habitat are hereby incorporated as conditions of this permit. Your authorization under this Corps permit is conditional upon your compliance with all of the mandatory Reasonable and Prudent Measures and Terms and Conditions contained in the Biological Opinion.

Your work is authorized by the above referenced permit provided it is accomplished in strict accordance with the attached conditions and your submitted plans. Any violation of the attached conditions or deviation from your submitted plans may subject the permittee to a stop work order, a restoration order and/or appropriate legal action.

This verification is valid until the NWP is modified, reissued, or revoked. All of the existing NWPs are scheduled to be modified, reissued, or revoked prior to March 18, 2007. It is incumbent upon you to remain informed of changes to the NWPs. We will issue a public notice when the NWPs are reissued. Furthermore, if you commence or are under contract to commence this activity before the date that the relevant nationwide permit is modified or revoked, you will have twelve (12) months from the date of the modification or revocation of the NWP to complete the activity under the present terms and conditions of this nationwide permit. If, prior to the expiration date identified below, the nationwide permit authorization is reissued and/or modified, this verification will remain valid until the expiration date identified below, provided it complies with all new and/or modified terms and conditions. The District Engineer may, at any time, exercise his discretionary authority to modify, suspend, or revoke a case specific activity's authorization under any NWP.

Activities subject to Section 404 (as indicated above) may also require an individual Section 401 Water Quality Certification. You should contact the NC Division of Water Quality (telephone (919) 733-1786) to determine Section 401 requirements.

For activities occurring within the twenty coastal counties subject to regulation under the Coastal Area Management Act (CAMA), prior to beginning work you must contact the N.C. Division of Coastal Management .

This Department of the Army verification does not relieve the permittee of the responsibility to obtain any other required Federal, State or local approvals/permits.

If there are any questions regarding this verification, any of the conditions of the Permit, or the Corps of Engineers regulatory program, please contact David Baker at 828-271-7980 x 226.

Corps Regulatory Official David Baker

Date: December 5, 2006

Expiration Date of Verification: March 18, 2007

Permit Number: SAW-2006-41203-300
Permit Type: NWP 23 and 33
Name of County: Mitchell and Yancey
Name of Permittee: NCDOT, Gregory J. Thorpe, Ph.D, Environmental Management Director
Date of Issuance: December 5, 2006
Project Manager: David Baker

Upon Completion of the activity authorized by this permit and any mitigation required by the permit, sign this certification and return it to the following address:

U.S. Army Corps of Engineers
Attention: CESAW-RG-A
151 Patton Avenue, Room 208
Asheville, North Carolina 28801-5006

Please note that your permitted activity is subject to a compliance inspection by an U.S. Army Corps of Engineers representative. If you fail to comply with this permit you are subject to permit suspension, modification, or revocation.

I hereby certify that the work authorized by the above referenced permit has been completed in accordance with the terms and conditions of the said permit, and required mitigation was completed in accordance with the permit conditions.

Signature of Permittee

Date



☒ North Carolina Wildlife Resources Commission ☒

Richard B. Hamilton, Executive Director

TO: Steve Lund, NCDOT Coordinator
Asheville Regulatory Field Office, USACE

FROM: Marla Chambers, Western NCDOT Permit Coordinator *Marla Chambers*
Habitat Conservation Program, NCWRC

DATE: November 27, 2006

SUBJECT: Review of the Section 404 & 401 permit application by NCDOT to replace Bridge No. 143 on SR 1304 (Tipton Hill Road/Ray Road) over the North Toe River, Yancey and Mitchell Counties, North Carolina. TIP No. B-2848.

North Carolina Department of Transportation (NCDOT) has submitted an application to obtain a Section 404 Permit from the U.S. Army Corps of Engineers (USACE) and a 401 Water Quality Certification from the Division of Water Quality (NCDWQ). Staff biologists with the North Carolina Wildlife Resources Commission (NCWRC) have reviewed the information provided, including a "Categorical Exclusion" by NCDOT and a Biological Opinion from the US Fish and Wildlife Service (USFWS). These comments are provided in accordance with the provisions of the National Environmental Policy Act (42 U.S.C. 4332(2)(c)) and the Fish and Wildlife Coordination Act (48 Stat. 401, as amended; 16 U.S.C. 661-667d).

The NCDOT proposes to replace Bridge No. 143 on SR 1304 (Tipton Hill Road/Ray Road) over the North Toe River with a new bridge on a new alignment to the northwest of the existing location. Traffic will be maintained on the existing bridge. Less than 0.01 acre (100 square feet) of permanent impacts to the river are proposed due to the construction of a bridge pier, where the number of piers in the water will be reduced from three to one. According to the Biological Opinion (BO), this will reduce pier impacts from the existing 349 square feet to the proposed 32 square feet. Temporary impacts totaling 0.35 acre are proposed in the form of temporary rock causeways and temporary support structures.

The North Toe River, classified C Trout, is inhabited by the federal and state Endangered (E) Appalachian elktoe (*Alasmidonta raveneliana*) and numerous other non-game aquatic species in

Mailing Address: Division of Inland Fisheries • 1721 Mail Service Center • Raleigh, NC 27699-1721
Telephone: (919) 707-0220 • **Fax:** (919) 707-0028

the project area, including state listed species and a Federal Species of Concern (FSC). The wavy-rayed lampmussel (*Lampsilis fasciola*), state Special Concern, has been collected at the bridge site. Other species that may be present include the sharphead darter (*Etheostoma acuticeps*), FSC and state Threatened (T); logperch (*Percina caprodes*), state T; stonecat (*Noturus flavus*), state E; and striped shiner (*Luxilus chrysocephalus*), state T. This section of the North Toe River is designated as a Significant Natural Heritage Area by the North Carolina Natural Heritage Program (NCNHP). We are very concerned about the cumulative effects of this project combined with the development occurring and proposed in the watershed.

Formatted: Font: Italic

We concur with the project commitments proposed in the document and recommend that all conservation measures and recommendations in the Biological Opinion be strictly adhered to. In addition, NCWRC can concur with the issuance of the Section 404 and 401 permits provided that the following conditions are implemented:

1. Sediment and erosion control measures should, at a minimum, adhere to the design standards for sensitive watersheds and be strictly maintained until project completion to avoid impacts to downstream aquatic resources.
2. Temporary or permanent herbaceous vegetation should be planted on all bare soil as soon as possible and within 10 calendar days of ground disturbing activities to provide long-term erosion control.
3. Tall fescue should not be used in riparian areas. We encourage NCDOT to utilize onsite vegetation and materials for riverbank stabilization when practicable. Erosion control matting should be used on banks and steep slopes, instead of straw mulch and well anchored with 12" staples or 12" wooden survey stakes.
4. Only clean, sediment-free rock should be used as temporary fill (causeways), and should be removed without excessive disturbance of the natural river bottom when construction is completed.
5. Discharge of materials into the river from demolition of the old bridge should be avoided as much as practicable. Any materials that inadvertently reach the water should be removed.
6. The natural dimension, pattern, and profile of the river above and below the crossing should not be modified by widening the channel or changing the depth of the river.
7. Removal of vegetation in riparian areas should be minimized. Native trees and shrubs should be planted along the banks to reestablish the riparian zone and to provide long-term erosion control.
8. Grading and backfilling should be minimized, and tree and shrub growth should be retained if possible to ensure long term availability of shoreline cover for fish and wildlife. Backfill materials should be obtained from upland sites.

9. Riprap placed for bank stabilization should be limited to the riverbank below the high water mark, and vegetation should be used for stabilization above the high water elevation.
10. Stormwater; including deck drainage, should be directed to buffer areas or retention basins and should not be routed directly into the river.
11. If concrete will be used during construction, work must be accomplished so that wet (uncured) concrete does not contact surface waters. This will lessen the chance of altering the water chemistry and causing a fish kill.
12. Discharging hydroseeding mixtures and washing out hydroseeders and other equipment in or adjacent to surface waters is strictly prohibited.
13. Heavy equipment should be operated from the bank rather than in the river channel whenever possible in order to minimize sedimentation and reduce the likelihood of introducing other pollutants into the stream. All mechanized equipment operated near surface waters should be inspected and maintained regularly to prevent contamination of surface waters from fuels, lubricants, hydraulic fluids or other toxic materials.
14. The existing roadway that is to be eliminated should be removed back to original ground elevations and the natural floodplain elevations and functions should be restored. Disturbed areas should be seeded or mulched to stabilize the soil and native tree species should be planted with a spacing of not more than 10'x10'.

Thank you for the opportunity to review and comment on this project. If you have any questions regarding these comments, please contact me at (704) 545-3841.

cc: Denise Moldenhauer, USFWS
Brian Wrenn, NCDWQ
Angie Rodgers, NCNHP
Elizabeth Lusk, NCDOT
Carla Dagnino, NCDOT

NATIONWIDE PERMIT 23
DEPARTMENT OF THE ARMY
CORPS OF ENGINEERS
FINAL NOTICE OF ISSUANCE AND MODIFICATION OF NATIONWIDE PERMITS
FEDERAL REGISTER
AUTHORIZED MARCH 18, 2002

Approved Categorical Exclusions: Activities undertaken, assisted, authorized, regulated, funded, or financed, in whole or in part, by another Federal agency or department where that agency or department has determined, pursuant to the Council on Environmental Quality Regulation for Implementing the Procedural Provisions of the National Environmental Policy Act (NEPA) (40 CFR part 1500 et seq.), that the activity, work, or discharge is categorically excluded from environmental documentation because it is included within a category of actions which neither individually nor cumulatively have a significant effect on the human environment, and the Office of the Chief of Engineers (ATTN: CECW-OR) has been furnished notice of the agency's or department's application for the categorical exclusion and concurs with that determination. Before to approval for purposes of this nationwide permit of any agency's categorical exclusions, the Chief of Engineers will solicit public comment. In addressing these comments, the Chief of Engineers may require certain conditions for authorization of an agency's categorical exclusions under this nationwide permit. (Sections 10 and 404)

NATIONWIDE PERMIT 33
DEPARTMENT OF THE ARMY
CORPS OF ENGINEERS
FINAL NOTICE OF ISSUANCE AND MODIFICATION OF NATIONWIDE PERMITS
FEDERAL REGISTER
AUTHORIZED MARCH 18, 2002

Temporary Construction, Access and Dewatering: Temporary structures, work and discharges, including cofferdams, necessary for construction activities or access fills or dewatering of construction sites; provided that the associated primary activity is authorized by the Corps of Engineers or the U.S. Coast Guard (USCG), or for other construction activities not subject to the Corps or USCG regulations. Appropriate measures must be taken to maintain near normal downstream flows and to minimize flooding. Fill must be of materials, and placed in a manner, that will not be eroded by expected high flows. The use of dredged material may be allowed if it is determined by the District Engineer that it will not cause more than minimal adverse effects on aquatic resources. Temporary fill must be entirely removed to upland areas, or dredged material returned to its original location, following completion of the construction activity, and the affected areas must be restored to the pre-project conditions. Cofferdams cannot be used to dewater wetlands or other aquatic areas so as to change their use. Structures left in place after cofferdams are removed require a section 10 permit if located in navigable waters of the United States. (See 33 CFR part 322). The permittee must notify the District Engineer in accordance with the "Notification" general condition. The notification must also include a restoration plan of reasonable measures to avoid and minimize adverse effects to aquatic resources. The District Engineer will add special conditions, where necessary, to ensure environmental adverse effects is minimal. Such conditions may include: Limiting the temporary work to the minimum necessary; requiring seasonal restrictions; modifying the restoration plan; and requiring alternative construction methods (e.g., construction mats in wetlands where practicable.). (Sections 10 and 404)

NATIONWIDE PERMIT GENERAL CONDITIONS

The following General Conditions must be followed in order for any authorization by a NWP to be valid:

1. Navigation. No activity may cause more than a minimal adverse effect on navigation.
2. Proper Maintenance. Any structure or fill authorized shall be properly maintained, including maintenance to ensure public safety.
3. Soil Erosion and Sediment Controls. Appropriate soil erosion and sediment controls must be used and maintained in effective operating condition during construction, and all exposed soil and other fills, as well as any work below the ordinary high water mark or high tide line, must be permanently stabilized at the earliest practicable date. Permittees are encouraged to perform work within waters of the United States during periods of low-flow or no-flow.
4. Aquatic Life Movements. No activity may substantially disrupt the necessary life-cycle movements of those species of aquatic life indigenous to the waterbody, including those species that normally migrate through the area, unless the activity's primary purpose is to impound water. Culverts placed in streams must be installed to maintain low flow conditions.
5. Equipment. Heavy equipment working in wetlands must be placed on mats, or other measures must be taken to minimize soil disturbance.
6. Regional and Case-By-Case Conditions. The activity must comply with any regional conditions that may have been added by the Division Engineer (see 33 CFR 330.4(e)) and with any case specific conditions added by the Corps or by the state or tribe in its Section 401 Water Quality Certification and Coastal Zone Management Act consistency determination.
7. Wild and Scenic Rivers. No activity may occur in a component of the National Wild and Scenic River System; or in a river officially designated by Congress as a 'study river' for possible inclusion in the system, while the river is in an official study status; unless the appropriate Federal agency, with direct management responsibility for such river, has determined in writing that the proposed activity will not adversely affect the Wild and Scenic River designation, or study status. Information on Wild and Scenic Rivers may be obtained from the appropriate Federal land management agency in the area (e.g., National Park Service, U.S. Forest Service, Bureau of Land Management, U.S. Fish and Wildlife Service).
8. Tribal Rights. No activity or its operation may impair reserved tribal rights, including, but not limited to, reserved water rights and treaty fishing and hunting rights.
9. Water Quality.

a. In certain states and tribal lands an individual 401 Water Quality Certification must be obtained or waived (See 33 CFR 330.4(c)).

b. For NWP's 12, 14, 17, 18, 32, 39, 40, 42, 43, and 44, where the state or tribal 401 certification (either generically or individually) does not require or approve water quality management measures, the permittee must provide water quality management measures that will ensure that the authorized work does not result in more than minimal degradation of water quality (or the Corps determines that compliance with state or local standards, where applicable, will ensure no more than minimal adverse effect on water quality). An important component of water quality management includes stormwater management that minimizes degradation of the downstream aquatic system, including water quality (refer to General Condition 21 for stormwater management requirements). Another important component of water quality management is the establishment and maintenance of vegetated buffers next to open waters, including streams (refer to General Condition 19 for vegetated buffer requirements for the NWP's).

This condition is only applicable to projects that have the potential to affect water quality. While appropriate measures must be taken, in most cases it is not necessary to conduct detailed studies to identify such measures or to require monitoring.

10. Coastal Zone Management. In certain states, an individual state coastal zone management consistency concurrence must be obtained or waived (see 33 CFR 330.4(d)).

11. Endangered Species.

a. No activity is authorized under any NWP which is likely to jeopardize the continued existence of a threatened or endangered species or a species proposed for such designation, as identified under the Federal Endangered Species Act (ESA), or which will destroy or adversely modify the critical habitat of such species. Non-federal permittees shall notify the District Engineer if any listed species or designated critical habitat might be affected or is in the vicinity of the project, or is located in the designated critical habitat and shall not begin work on the activity until notified by the District Engineer that the requirements of the ESA have been satisfied and that the activity is authorized. For activities that may affect Federally-listed endangered or threatened species or designated critical habitat, the notification must include the name(s) of the endangered or threatened species that may be affected by the proposed work or that utilize the designated critical habitat that may be affected by the proposed work. As a result of formal or informal consultation with the FWS or NMFS the District Engineer may add species-specific regional endangered species conditions to the NWP's.

b. Authorization of an activity by a NWP does not authorize the "take" of a threatened or endangered species as defined under the ESA. In the absence of separate authorization (e.g., an ESA Section 10 Permit, a Biological Opinion with "incidental take" provisions, etc.) from the USFWS or the NMFS, both lethal and non-lethal "takes" of protected species are in violation of the ESA. Information on the location of threatened and endangered species and their critical habitat can be obtained directly from the offices of the USFWS and NMFS or their World Wide

Web pages at <http://www.fws.gov/r9endspp/endspp.html> and <http://www.nfms.noaa.gov/protres/overview/es.html> respectively.

12. Historic Properties. No activity that may affect historic properties listed, or eligible for listing, in the National Register of Historic Places is authorized, until the District Engineer has complied with the provisions of 33 CFR part 325, Appendix C. The prospective permittee must notify the District Engineer if the authorized activity may affect any historic properties listed, determined to be eligible, or which the prospective permittee has reason to believe may be eligible for listing on the National Register of Historic Places, and shall not begin the activity until notified by the District Engineer that the requirements of the National Historic Preservation Act have been satisfied and that the activity is authorized. Information on the location and existence of historic resources can be obtained from the State Historic Preservation Office and the National Register of Historic Places (see 33 CFR 330.4(g)). For activities that may affect historic properties listed in, or eligible for listing in, the National Register of Historic Places, the notification must state which historic property may be affected by the proposed work or include a vicinity map indicating the location of the historic property.

13. Notification.

a. Timing; where required by the terms of the NWP, the prospective permittee must notify the District Engineer with a preconstruction notification (PCN) as early as possible. The District Engineer must determine if the notification is complete within 30 days of the date of receipt and can request additional information necessary to make the PCN complete only once. However, if the prospective permittee does not provide all of the requested information, then the District Engineer will notify the prospective permittee that the notification is still incomplete and the PCN review process will not commence until all of the requested information has been received by the District Engineer. The prospective permittee shall not begin the activity:

1. Until notified in writing by the District Engineer that the activity may proceed under the NWP with any special conditions imposed by the District or Division Engineer; or

2. If notified in writing by the District or Division Engineer that an Individual Permit is required; or

3. Unless 45 days have passed from the District Engineer's receipt of the complete notification and the prospective permittee has not received written notice from the District or Division Engineer. Subsequently, the permittee's right to proceed under the NWP may be modified, suspended, or revoked only in accordance with the procedure set forth in 33 CFR 330.5(d)(2).

b. Contents of Notification: The notification must be in writing and include the following information:

1. Name, address and telephone numbers of the prospective permittee;

2. Location of the proposed project;

3. Brief description of the proposed project; the project's purpose; direct and indirect adverse environmental effects the project would cause; any other NWP(s), Regional General Permit(s), or Individual Permit(s) used or intended to be used to authorize any part of the proposed project or any related activity. Sketches should be provided when necessary to show that the activity complies with the terms of the NWP (Sketches usually clarify the project and when provided result in a quicker decision.);

4. For NWPs 7, 12, 14, 18, 21, 34, 38, 39, 40, 41, 42, and 43, the PCN must also include a delineation of affected special aquatic sites, including wetlands, vegetated shallows (e.g., submerged aquatic vegetation, seagrass beds), and riffle and pool complexes (see paragraph 13(f));

5. For NWP 7 (Cutfall Structures and Maintenance), the PCN must include information regarding the original design capacities and configurations of those areas of the facility where maintenance dredging or excavation is proposed;

6. For NWP 14 (Linear Transportation Projects), the PCN must include a compensatory mitigation proposal to offset permanent losses of waters of the US and a statement describing how temporary losses of waters of the US will be minimized to the maximum extent practicable;

7. For NWP 21 (Surface Coal Mining Activities), the PCN must include an Office of Surface Mining (OSM) or state-approved mitigation plan, if applicable. To be authorized by this NWP, the District Engineer must determine that the activity complies with the terms and conditions of the NWP and that the adverse environmental effects are minimal both individually and cumulatively and must notify the project sponsor of this determination in writing;

8. For NWP 27 (Stream and Wetland Restoration Activities), the PCN must include documentation of the prior condition of the site that will be reverted by the permittee;

9. For NWP 29 (Single-Family Housing), the PCN must also include:

i. Any past use of this NWP by the Individual Permittee and/or the permittee's spouse;

ii. A statement that the single-family housing activity is for a personal residence of the permittee;

iii. A description of the entire parcel, including its size, and a delineation of wetlands. For the purpose of this NWP, parcels of land measuring $\frac{1}{4}$ -acre or less will not require a formal on-site delineation. However, the applicant shall provide an indication of where the wetlands are and the amount of wetlands that exists on the property. For parcels greater than $\frac{1}{4}$ -acre in size, formal wetland delineation must be prepared in accordance with the current

method required by the Corps. (See paragraph 13(f));

iv. A written description of all land (including, if available, legal descriptions) owned by the prospective permittee and/or the prospective permittee's spouse, within a one mile radius of the parcel, in any form of ownership (including any land owned as a partner, corporation, joint tenant, co-tenant, or as a tenant-by-the-entirety) and any land on which a purchase and sale agreement or other contract for sale or purchase has been executed;

10. For NWP 31 (Maintenance of Existing Flood Control Facilities), the prospective permittee must either notify the District Engineer with a PCN prior to each maintenance activity or submit a five-year (or less) maintenance plan. In addition, the PCN must include all of the following:

i. Sufficient baseline information identifying the approved channel depths and configurations and existing facilities. Minor deviations are authorized, provided the approved flood control protection or drainage is not increased;

ii. A delineation of any affected special aquatic sites, including wetlands; and,

iii. Location of the dredged material disposal site;

11. For NWP 33 (Temporary Construction, Access, and Dewatering), the PCN must also include a restoration plan of reasonable measures to avoid and minimize adverse effects to aquatic resources;

12. For NWPs 39, 43 and 44, the PCN must also include a written statement to the District Engineer explaining how avoidance and minimization for losses of waters of the US were achieved on the project site;

13. For NWP 39 and NWP 42, the PCN must include a compensatory mitigation proposal to offset losses of waters of the US or justification explaining why compensatory mitigation should not be required. For discharges that cause the loss of greater than 300 linear feet of an intermittent stream bed, to be authorized, the District Engineer must determine that the activity complies with the other terms and conditions of the NWP, determine adverse environmental effects are minimal both individually and cumulatively, and waive the limitation on stream impacts in writing before the permittee may proceed;

14. For NWP 40 (Agricultural Activities), the PCN must include a compensatory mitigation proposal to offset losses of waters of the US. This NWP does not authorize the relocation of greater than 300 linear feet of existing serviceable drainage ditches constructed in non-tidal streams unless, for drainage ditches constructed in intermittent nontidal streams, the District Engineer waives this criterion in writing, and the District Engineer has determined that the project complies with all terms and conditions of this NWP, and that any adverse impacts of the project on the aquatic environment are minimal, both individually and cumulatively;

15. For NWP 43 (Stormwater Management Facilities), the PCN must include, for the construction of new stormwater management facilities, a maintenance plan (in accordance with state and local requirements, if applicable) and a compensatory mitigation proposal to offset losses of waters of the US. For discharges that cause the loss of greater than 300 linear feet of an intermittent stream bed, to be authorized, the District Engineer must determine that the activity complies with the other terms and conditions of the NWP, determine adverse environmental effects are minimal both individually and cumulatively, and waive the limitation on stream impacts in writing before the permittee may proceed;

16. For NWP 44 (Mining Activities), the PCN must include a description of all waters of the US adversely affected by the project, a description of measures taken to minimize adverse effects to waters of the US, a description of measures taken to comply with the criteria of the NWP, and a reclamation plan (for all aggregate mining activities in isolated waters and non-tidal wetlands adjacent to headwaters and any hard rock/mineral mining activities);

17. For activities that may adversely affect Federally-listed endangered or threatened species, the PCN must include the name(s) of those endangered or threatened species that may be affected by the proposed work or utilize the designated critical habitat that may be affected by the proposed work; and

18. For activities that may affect historic properties listed in, or eligible for listing in, the National Register of Historic Places, the PCN must state which historic property may be affected by the proposed work or include a vicinity map indicating the location of the historic property.

c. Form of Notification: The standard Individual Permit application form (Form ENG 4345) may be used as the notification but must clearly indicate that it is a PCN and must include all of the information required in (b) (1)-(18) of General Condition 13. A letter containing the requisite information may also be used.

d. District Engineer's Decision: In reviewing the PCN for the proposed activity, the District Engineer will determine whether the activity authorized by the NWP will result in more than minimal individual or cumulative adverse environmental effects or may be contrary to the public interest. The prospective permittee may submit a proposed mitigation plan with the PCN to expedite the process. The District Engineer will consider any proposed compensatory mitigation the applicant has included in the proposal in determining whether the net adverse environmental effects to the aquatic environment of the proposed work are minimal. If the District Engineer determines that the activity complies with the terms and conditions of the NWP and that the adverse effects on the aquatic environment are minimal, after considering mitigation, the District Engineer will notify the permittee and include any conditions the District Engineer deems necessary. The District Engineer must approve any compensatory mitigation proposal before the permittee commences work. If the prospective permittee is required to submit a compensatory mitigation proposal with the PCN, the proposal may be either conceptual or detailed. If the prospective permittee elects to submit a compensatory mitigation plan with the PCN, the District Engineer will expeditiously review the proposed compensatory mitigation

plan. The District Engineer must review the plan within 45 days of receiving a complete PCN and determine whether the conceptual or specific proposed mitigation would ensure no more than minimal adverse effects on the aquatic environment. If the net adverse effects of the project on the aquatic environment (after consideration of the compensatory mitigation proposal) are determined by the District Engineer to be minimal, the District Engineer will provide a timely written response to the applicant. The response will state that the project can proceed under the terms and conditions of the NWP.

If the District Engineer determines that the adverse effects of the proposed work are more than minimal, then the District Engineer will notify the applicant either:

1. That the project does not qualify for authorization under the NWP and instruct the applicant on the procedures to seek authorization under an Individual Permit;
2. that the project is authorized under the NWP subject to the applicant's submission of a mitigation proposal that would reduce the adverse effects on the aquatic environment to the minimal level; or
3. that the project is authorized under the NWP with specific modifications or conditions. Where the District Engineer determines that mitigation is required to ensure no more than minimal adverse effects occur to the aquatic environment, the activity will be authorized within the 45-day PCN period. The authorization will include the necessary conceptual or specific mitigation or a requirement that the applicant submit a mitigation proposal that would reduce the adverse effects on the aquatic environment to the minimal level. When conceptual mitigation is included, or a mitigation plan is required under item (2) above, no work in waters of the US will occur until the District Engineer has approved a specific mitigation plan.

e. Agency Coordination: The District Engineer will consider any comments from Federal and state agencies concerning the proposed activity's compliance with the terms and conditions of the NWPs and the need for mitigation to reduce the project's adverse environmental effects to a minimal level.

For activities requiring notification to the District Engineer that result in the loss of greater than 1/2-acre of waters of the US, the District Engineer will provide immediately (e.g., via facsimile transmission, overnight mail, or other expeditious manner) a copy to the appropriate Federal or state offices (USFWS, state natural resource or water quality agency, EPA, State Historic Preservation Officer (SHPO), and, if appropriate, the NMFS). With the exception of NWP 37, these agencies will then have 10 calendar days from the date the material is transmitted to telephone or fax the District Engineer notice that they intend to provide substantive, site-specific comments. If so contacted by an agency, the District Engineer will wait an additional 15 calendar days before making a decision on the notification. The District Engineer will fully consider agency comments received within the specified time frame, but will provide no response to the resource agency, except as provided below. The District Engineer will indicate in the administrative record associated with each notification that the resource agencies' concerns were considered. As required by section 305(b)(4)(B) of the Magnuson-Stevens

Fishery Conservation and Management Act, the District Engineer will provide a response to NMFS within 30 days of receipt of any Essential Fish Habitat conservation recommendations. Applicants are encouraged to provide the Corps multiple copies of notifications to expedite agency notification.

f. Wetland Delineations: Wetland delineations must be prepared in accordance with the current method required by the Corps (For NWP 29 see paragraph (b)(9)(iii) for parcels less than $\frac{1}{4}$ -acre in size). The permittee may ask the Corps to delineate the special aquatic site. There may be some delay if the Corps does the delineation. Furthermore, the 45-day period will not start until the wetland delineation has been completed and submitted to the Corps, where appropriate.

14. Compliance Certification. Every permittee who has received NWP verification from the Corps will submit a signed certification regarding the completed work and any required mitigation. The certification will be forwarded by the Corps with the authorization letter and will include:

a. A statement that the authorized work was done in accordance with the Corps authorization, including any general or specific conditions;

b. A statement that any required mitigation was completed in accordance with the permit conditions; and

c. The signature of the permittee certifying the completion of the work and mitigation.

15. Use of Multiple Nationwide Permits. The use of more than one NWP for a single and complete project is prohibited, except when the acreage loss of waters of the US authorized by the NWPs does not exceed the acreage limit of the NWP with the highest specified acreage limit (e.g. if a road crossing over tidal waters is constructed under NWP 14, with associated bank stabilization authorized by NWP 13, the maximum acreage loss of waters of the US for the total project cannot exceed $\frac{1}{3}$ -acre).

16. Water Supply Intakes. No activity, including structures and work in navigable waters of the US or discharges of dredged or fill material, may occur in the proximity of a public water supply intake except where the activity is for repair of the public water supply intake structures or adjacent bank stabilization.

17. Shellfish Beds. No activity, including structures and work in navigable waters of the US or discharges of dredged or fill material, may occur in areas of concentrated shellfish populations, unless the activity is directly related to a shellfish harvesting activity authorized by NWP 4.

18. Suitable Material. No activity, including structures and work in navigable waters of the US or discharges of dredged or fill material, may consist of unsuitable material (e.g., trash, debris, car bodies, asphalt, etc.) and material used for construction or discharged must be free

from toxic pollutants in toxic amounts (see section 307 of the CWA).

19. Mitigation. The District Engineer will consider the factors discussed below when determining the acceptability of appropriate and practicable mitigation necessary to offset adverse effects on the aquatic environment that are more than minimal.

a. The project must be designed and constructed to avoid and minimize adverse effects to waters of the US to the maximum extent practicable at the project site (i.e., on site).

b. Mitigation in all its forms (avoiding, minimizing, rectifying, reducing or compensating) will be required to the extent necessary to ensure that the adverse effects to the aquatic environment are minimal.

c. Compensatory mitigation at a minimum one-for-one ratio will be required for all wetland impacts requiring a PCN, unless the District Engineer determines in writing that some other form of mitigation would be more environmentally appropriate and provides a project-specific waiver of this requirement. Consistent with National policy, the District Engineer will establish a preference for restoration of wetlands as compensatory mitigation, with preservation used only in exceptional circumstances.

d. Compensatory mitigation (i.e., replacement or substitution of aquatic resources for those impacted) will not be used to increase the acreage losses allowed by the acreage limits of some of the NWPs. For example, $\frac{1}{4}$ -acre of wetlands cannot be created to change a $\frac{3}{4}$ -acre loss of wetlands to a $\frac{1}{2}$ -acre loss associated with NWP 39 verification. However, $\frac{1}{2}$ -acre of created wetlands can be used to reduce the impacts of a $\frac{1}{2}$ -acre loss of wetlands to the minimum impact level in order to meet the minimal impact requirement associated with NWPs.

e. To be practicable, the mitigation must be available and capable of being done considering costs, existing technology, and logistics in light of the overall project purposes. Examples of mitigation that may be appropriate and practicable include, but are not limited to: reducing the size of the project; establishing and maintaining wetland or upland vegetated buffers to protect open waters such as streams; and replacing losses of aquatic resource functions and values by creating, restoring, enhancing, or preserving similar functions and values, preferably in the same watershed.

f. Compensatory mitigation plans for projects in or near streams or other open waters will normally include a requirement for the establishment, maintenance, and legal protection (e.g., easements, deed restrictions) of vegetated buffers to open waters. In many cases, vegetated buffers will be the only compensatory mitigation required. Vegetated buffers should consist of native species. The width of the vegetated buffers required will address documented water quality or aquatic habitat loss concerns. Normally, the vegetated buffer will be 25 to 50 feet wide on each side of the stream, but the District Engineers may require slightly wider vegetated buffers to address documented water quality or habitat loss concerns. Where both wetlands and open waters exist on the project site, the Corps will determine the appropriate compensatory mitigation (e.g., stream buffers or wetlands compensation) based on what is best for the aquatic

environment or, a watershed basis. In cases where vegetated buffers are determined to be the most appropriate form of compensatory mitigation, the District Engineer may waive or reduce the requirement to provide wetland compensatory mitigation for wetland impacts.

g. Compensatory mitigation proposals submitted with the " notification" may be either conceptual or detailed. If conceptual plans are approved under the verification, then the Corps will condition the verification to require detailed plans be submitted and approved by the Corps prior to construction of the authorized activity in waters of the US.

h. Permittees may propose the use of mitigation banks, in-lieu fee arrangements or separate activity-specific compensatory mitigation. In all cases that require compensatory mitigation, the mitigation provisions will specify the party responsible for accomplishing and/or complying with the mitigation plan.

20. Spawning Areas. Activities, including structures and work in navigable waters of the US or discharges of dredged or fill material, in spawning areas during spawning seasons must be avoided to the maximum extent practicable. Activities that result in the physical destruction (e.g., excavate, fill, or smother downstream by substantial turbidity) of an important spawning area are not authorized.

21. Management of Water Flows. To the maximum extent practicable, the activity must be designed to maintain preconstruction downstream flow conditions (e.g., location, capacity, and flow rates). Furthermore, the activity must not permanently restrict or impede the passage of normal or expected high flows (unless the primary purpose of the fill is to impound waters) and the structure or discharge of dredged or fill material must withstand expected high flows. The activity must, to the maximum extent practicable, provide for retaining excess flows from the site, provide for maintaining surface flow rates from the site similar to preconstruction conditions, and provide for not increasing water flows from the project site, relocating water, or redirecting water flow beyond preconstruction conditions. Stream channelizing will be reduced to the minimal amount necessary, and the activity must, to the maximum extent practicable, reduce adverse effects such as flooding or erosion downstream and upstream of the project site, unless the activity is part of a larger system designed to manage water flows. In most cases, it will not be a requirement to conduct detailed studies and monitoring of water flow.

This condition is only applicable to projects that have the potential to affect waterflows. While appropriate measures must be taken, it is not necessary to conduct detailed studies to identify such measures or require monitoring to ensure their effectiveness. Normally, the Corps will defer to state and local authorities regarding management of water flow.

22. Adverse Effects From Impoundments. If the activity creates an impoundment of water, adverse effects to the aquatic system due to the acceleration of the passage of water, and/or the restricting its flow shall be minimized to the maximum extent practicable. This includes structures and work in navigable waters of the US, or discharges of dredged or fill material.

23. Waterfowl Breeding Areas. Activities, including structures and work in navigable

waters of the US or discharges of dredged or fill material, into breeding areas for migratory waterfowl must be avoided to the maximum extent practicable.

24. Removal of Temporary Fills. Any temporary fills must be removed in their entirety and the affected areas returned to their preexisting elevation.

25. Designated Critical Resource Waters. Critical resource waters include, NOAA-designated marine sanctuaries, National Estuarine Research Reserves, National Wild and Scenic Rivers, critical habitat for Federally listed threatened and endangered species, coral reefs, state natural heritage sites, and outstanding national resource waters or other waters officially designated by a state as having particular environmental or ecological significance and identified by the District Engineer after notice and opportunity for public comment. The District Engineer may also designate additional critical resource waters after notice and opportunity for comment.

a. Except as noted below, discharges of dredged or fill material into waters of the US are not authorized by NWPs 7, 12, 14, 16, 17, 21, 29, 31, 35, 39, 40, 42, 43, and 44 for any activity within, or directly affecting, critical resource waters, including wetlands adjacent to such waters. Discharges of dredged or fill materials into waters of the US may be authorized by the above NWPs in National Wild and Scenic Rivers if the activity complies with General Condition 7. Further, such discharges may be authorized in designated critical habitat for Federally listed threatened or endangered species if the activity complies with General Condition 11 and the USFWS or the NMFS has concurred in a determination of compliance with this condition.

b. For NWPs 3, 8, 10, 13, 15, 18, 19, 22, 23, 25, 27, 28, 30, 33, 34, 36, 37, and 38, notification is required in accordance with General Condition 13, for any activity proposed in the designated critical resource waters including wetlands adjacent to those waters. The District Engineer may authorize activities under these NWPs only after it is determined that the impacts to the critical resource waters will be no more than minimal.

26. Fills Within 100-Year Floodplains. For purposes of this General Condition, 100-year floodplains will be identified through the existing Federal Emergency Management Agency's (FEMA) Flood Insurance Rate Maps or FEMA-approved local floodplain maps.

a. Discharges in Floodplain; Below Headwaters. Discharges of dredged or fill material into waters of the US within the mapped 100-year floodplain, below headwaters (i.e. five cfs), resulting in permanent above-grade fills, are not authorized by NWPs 39, 40, 42, 43, and 44.

b. Discharges in Floodway; Above Headwaters. Discharges of dredged or fill material into waters of the US within the FEMA or locally mapped floodway, resulting in permanent above-grade fills, are not authorized by NWPs 39, 40, 42, and 44.

c. The permittee must comply with any applicable FEMA-approved state or local floodplain management requirements.

27. Construction Period. For activities that have not been verified by the Corps and the

project was commenced or under contract to commence by the expiration date of the NWP (or modification or revocation date), the work must be completed within 12-months after such date (including any modification that affects the project).

For activities that have been verified and the project was commenced or under contract to commence within the verification period, the work must be completed by the date determined by the Corps.

For projects that have been verified by the Corps, an extension of a Corps approved completion date may be requested. This request must be submitted at least one month before the previously approved completion date.

FURTHER INFORMATION

1. District Engineers have authority to determine if an activity complies with the terms and conditions of a NWP.
2. NWPs do not obviate the need to obtain other Federal, State, or local permits, approvals, or authorizations required by law.
3. NWPs do not grant any property rights or exclusive privileges.
4. NWPs do not authorize any injury to the property or rights of others.
5. NWPs do not authorize interference with any existing or proposed Federal project.

DEFINITIONS

Best Management Practices (BMPs): BMPs are policies, practices, procedures, or structures implemented to mitigate the adverse environmental effects on surface water quality resulting from development. BMPs are categorized as structural or nonstructural. A BMP policy may affect the limits on a development.

Compensatory Mitigation: For purposes of Section 10/404, compensatory mitigation is the restoration, creation, enhancement, or in exceptional circumstances, preservation of wetlands and/or other aquatic resources for the purpose of compensating for unavoidable adverse impacts, which remain, after all appropriate and practicable avoidance and minimization has been achieved.

Creation: The establishment of a wetland or other aquatic resource where one did not formerly exist.

Enhancement: Activities conducted in existing wetlands or other aquatic resources that increase

one or more aquatic functions.

Ephemeral Stream: An ephemeral stream has *flowing* water only during and for a short duration after, precipitation events in a typical year. Ephemeral stream beds are located above the water table year-round. Groundwater is not a source of water for the stream. Runoff from rainfall is the primary source of water for stream flow.

Farm Tract: A unit of contiguous land under one ownership that is operated as a farm or part of a farm.

Flood Fringe: That portion of the 100-year floodplain outside of the floodway (often referred to as “floodway fringe”).

Floodway: The area regulated by Federal, state, or local requirements to provide for the discharge of the base flood so the cumulative increase in water surface elevation is no more than a designated amount (not to exceed one foot as set by the National Flood Insurance Program) within the 100-year floodplain.

Independent Utility: A test to determine what constitutes a single and complete project in the Corps regulatory program. A project is considered to have independent utility if it would be constructed absent the construction of other projects in the project area. Portions of a multi-phase project that depend upon other phases of the project do not have independent utility. Phases of a project that would be constructed even if the other phases were not built can be considered as separate single and complete projects with independent utility.

Intermittent Stream: An intermittent stream has flowing water during certain times of the year, when groundwater provides water for stream flow. During dry periods, intermittent streams may not have flowing water. Runoff from rainfall is a supplemental source of water for stream flow.

Loss of waters of the US: Waters of the US that include the filled area and other waters that are permanently adversely affected by flooding, excavation, or drainage because of the regulated activity. Permanent adverse effects include permanent above-grade, at-grade, or below-grade fills that change an aquatic area to dry land, increase the bottom elevation of a waterbody, or change the use of a waterbody. The acreage of loss of waters of the US is the threshold measurement of the impact to existing waters for determining whether a project may qualify for a NWP; it is not a net threshold that is calculated after considering compensatory mitigation that may be used to offset losses of aquatic functions and values. The loss of stream bed includes the linear feet of stream bed that is filled or excavated. Waters of the US temporarily filled, flooded, excavated, or drained, but restored to preconstruction contours and elevations after construction, are not included in the measurement of loss of waters of the US. Impacts to ephemeral waters are only not included in the acreage or linear foot measurements of loss of waters of the US or loss of stream bed, for the purpose of determining compliance with the threshold limits of the NWPs.

Non-tidal Wetland: An area that, during a year with normal patterns of precipitation has

standing or flowing water for sufficient duration to establish an ordinary high water mark. Aquatic vegetation within the area of standing or flowing water is either non-emergent, sparse, or absent. Vegetated shallows are considered to be open waters. The term “open water” includes rivers, streams, lakes, and ponds. For the purposes of the NWP, this term does not include ephemeral waters.

Perennial Stream: A perennial stream has flowing water year-round during a typical year. The water table is located above the stream bed for the most of the year. Groundwater is the primary source of water for stream flow. Runoff from rainfall is a supplemental source of water for stream flow.

Permanent Above-grade Fill: A discharge of dredged or fill material into waters of the US, including wetlands, that results in a substantial increase in ground elevation and permanently converts part or all of the waterbody to dry land. Structural fills authorized by NWPs 3, 25, 36, etc. are not included.

Preservation: The protection of ecologically important wetlands or other aquatic resources in perpetuity through the implementation of appropriate legal and physical mechanisms. Preservation may include protection of upland areas adjacent to wetlands as necessary to ensure protection and/or enhancement of the overall aquatic ecosystem.

Restoration: Re-establishment of wetland and/or other aquatic resource characteristics and function(s) at a site where they have ceased to exist, or exist in a substantially degraded state.

Riffle and Pool Complex: Riffle and pool complexes are special aquatic sites under the 404(b)(1) Guidelines. Riffle and pool complexes sometimes characterize steep gradient sections of streams. Such stream sections are recognizable by their hydraulic characteristics. The rapid movement of water over a coarse substrate in riffles results in a rough flow, a turbulent surface and high dissolved oxygen levels in the water. Pools are deeper areas associated with riffles. A slower stream velocity, a streaming flow, a smooth surface, and a finer substrate characterize pools.

Single and Complete Project: The term “single and complete project” is defined at 33 CFR 330.2(i) as the total project proposed or accomplished by one owner/developer or partnership or other association of owners/developers (see definition of independent utility). For linear projects, the “single and complete project” (i.e., a single and complete crossing) will apply to each crossing of a separate water of the US (i.e., a single waterbody) at that location. An exception is for linear projects crossing a single waterbody several times at separate and distant locations; each crossing is considered a single and complete project. However, individual channels in a braided stream or river, or individual arms of a large, irregularly shaped wetland or lake, etc., are not separate waterbodies.

Stormwater Management: Stormwater management is the mechanism for controlling stormwater runoff for the purposes of reducing downstream erosion, water quality degradation, and flooding and mitigating the adverse effects of changes in land use on the aquatic environment.

Stormwater Management Facilities: Stormwater management facilities are those facilities, including but not limited to, stormwater retention and detention ponds and BMPs, which retain water for a period of time to control runoff and/or improve the quality (i.e., by reducing the concentration of nutrients, sediments, hazardous substances and other pollutants) of stormwater runoff.

Stream Channelization: The manipulation of a stream channel to increase the rate of water flow through the stream channel. Manipulation may include deepening, widening, straightening, armoring, or other activities that change the stream cross-section or other aspects of stream channel geometry to increase the rate of water flow through the stream channel. A channelized stream remains a water of the US, despite the modifications to increase the rate of water flow.

Tidal Wetland: A tidal wetland is a wetland (i.e., water of the US) that is inundated by tidal waters. The definitions of a wetland and tidal waters can be found at 33 CFR 328.3(b) and 33 CFR 328.3(f), respectively. Tidal waters rise and fall in a predictable and measurable rhythm or cycle due to the gravitational pulls of the moon and sun. Tidal waters end where the rise and fall of the water surface can no longer be practically measured in a predictable rhythm due to masking by other waters, wind, or other effects. Tidal wetlands are located channelward of the high tide line (i.e., spring high tide line) and are inundated by tidal waters two times per lunar month, during spring high tides.

Vegetated Buffer: A vegetated upland or wetland area next to rivers, streams, lakes, or other open waters, which separates the open water from developed areas, including agricultural land. Vegetated buffers provide a variety of aquatic habitat functions and values (e.g., aquatic habitat for fish and other aquatic organisms, moderation of water temperature changes, and detritus for aquatic food webs) and help improve or maintain local water quality. A vegetated buffer can be established by maintaining an existing vegetated area or planting native trees, shrubs, and herbaceous plants on land next to openwaters. Mowed lawns are not considered vegetated buffers because they provide little or no aquatic habitat functions and values. The establishment and maintenance of vegetated buffers is a method of compensatory mitigation that can be used in conjunction with the restoration, creation, enhancement or preservation of aquatic habitats to ensure that activities authorized by NWP result in minimal adverse effects to the aquatic environment. (See General Condition 19.)

Vegetated Shallows: Vegetated shallows are special aquatic sites under the 404(b)(1) Guidelines. They are areas that are permanently inundated and under normal circumstances have rooted aquatic vegetation, such as seagrasses in marine and estuarine systems and a variety of vascular rooted plants in freshwater systems.

Waterbody: A waterbody is any area that in a normal year has water flowing or standing above ground to the extent that evidence of an ordinary high water mark is established. Wetlands contiguous to the waterbody are considered part of the waterbody.

**FINAL REGIONAL CONDITIONS FOR NATIONWIDE PERMITS IN THE
WILMINGTON DISTRICT**

1. Waters Excluded from NWP or Subject to Additional Notification Requirements:

a. The Corps identified waters that will be excluded from use of this NWP. These waters are:

1. Discharges into Waters of the United States designated by either the North Carolina Division of Marine Fisheries (NCDMF) or the North Carolina Wildlife Resources Commission (NCWRC) as anadromous fish spawning area are prohibited during the period between February 15 and June 30, without prior written approval from NCDMF or NCWRC and the Corps.

2. Discharges into Waters of the United States designated as sturgeon spawning areas are prohibited during the period between February 1 and June 30, without prior written approval from the National Marine Fisheries Service (NMFS).

b. The Corps identified waters that will be subject to additional notification requirements for activities authorized by this NWP. These waters are:

1. Prior to the use of any NWP in any of the following North Carolina *designated waters*, applicants must comply with Nationwide Permit General Condition 13. In addition, the applicant must furnish a written statement of compliance with all of the conditions of the applicable Nationwide Permit. The North Carolina *designated waters* that require additional notification requirements are “Outstanding Resource Waters” (ORW) and “High Quality Waters” (HQW) (as defined by the North Carolina Division of Water Quality), or “Inland Primary Nursery Areas” (IPNA) (as defined by the North Carolina Wildlife Resources Commission), or contiguous wetlands (as defined by the North Carolina Division of Water Quality), or “Primary Nursery Areas” (PNA) (as defined by the North Carolina Division of Marine Fisheries).

2. Applicants for any NWP in a designated “Area of Environmental Concern” (AEC) in the twenty (20) coastal counties of Eastern North Carolina covered by the North Carolina Coastal Area Management Act (CAMA), must also obtain the required CAMA permit. Construction activities may not commence until a copy of the approved CAMA permit is furnished to the appropriate Wilmington District Regulatory Field Office (Wilmington Field Office – P.O. Box 1890, Wilmington, NC 28402 or Washington Field Office – P.O. Box 1000, Washington, NC 27889) for authorization to begin work.

3. Prior to the use of any NWP on a Barrier Island of North Carolina, applicants must comply with Nationwide Permit General Condition 13. In addition, the applicant shall furnish a written statement of compliance with all of the conditions listed of the applicable Nationwide Permit.

4. Prior to the use of any NWP in a "Mountain or Piedmont Bog" of North Carolina, applicants shall comply with Nationwide Permit General Condition 13. In addition, the applicant shall furnish a written statement of compliance with all of the conditions listed of the applicable NWP.

Note: The following wetland community types identified in the N.C. Natural Heritage Program document, "Classification of Natural communities of North Carolina (Michael P. Schafale and Alan S. Weakley, 1990), are subject to this regional condition.

Mountain Bogs

Swamp Forest-Bog Complex
Swamp Forest-Bog Complex (Spruce Subtype)
Southern Appalachian Bog (Northern Subtype)
Southern Appalachian Bog (Southern Subtype)
Southern Appalachian Fen

Piedmont Bogs

Upland Depression Swamp Forest

5. Prior to the use of any NWP in Mountain Trout Waters within twenty-five (25) designated counties of North Carolina, applicants shall comply with Nationwide General Condition 13. In addition, the applicant shall furnish a written statement of compliance with all of the conditions listed of the applicable NWP. Notification will include a letter of comments and recommendations from the North Carolina Wildlife Resources Commission (NCWRC), the location of work, a delineation of wetlands, a discussion of alternatives to working in the Mountain Trout Waters, why other alternatives were not selected, and a plan to provide compensatory mitigation for all unavoidable adverse impacts to the Mountain Trout Waters. To facilitate coordination with the NCWRC, the proponent may provide a copy of the notification to the NCWRC concurrent with the notification to the District Engineer. The NCWRC will respond both to the proponent and directly to the Corps of Engineers.

The twenty-five (25) designated counties are:

Alleghany	Ashe	Avery	Yancey
Buncombe	Burke	Caldwell	Wilkes
Cherokee	Clay	Graham	Swain
Haywood	Henderson	Jackson	Surry
Macon	Madison	McDowell	Stokes
Mitchell	Polk	Rutherford	
Transylvania	Watauga		

6. Applicants shall notify the NCDENR Shellfish Sanitation Section prior to dredging in or removing sediment from an area closed to shell fishing where the effluent may be released to an area open for shell fishing or swimming in order to avoid contamination of the disposal area and allow a temporary shellfish closure to be made. Any disposal of sand to the beach should occur between November 1 and April 30 when recreational usage is low. Only clean sand should be used and no dredged sand from closed shell fishing areas. If beach disposal was to occur at times other than stated above or if sand from a closed shell fishing area is to be used, a

swim advisory shall be posted and a press release shall be made. NCDENR Shellfish Sanitation Section must be notified before commencing this activity.

2. List of Final Corps Regional Modifications and Conditions for All Nationwide Permits

a. Individual or multiple NWPs may not be used for activities that result in the cumulative loss or degradation of greater than 300 total linear feet of perennial streambed or intermittent streambed that exhibits important aquatic function(s).

b. Prior to the use of any NWP (except 13, 27, and 39) for any activity that has more than a total of 150 total linear feet of perennial streambed impacts or intermittent streambed impacts (if the intermittent stream has important aquatic function), the applicant must comply with Nationwide Permit General Condition 13. In addition, the applicant shall furnish a written statement of compliance with all of the conditions listed of the applicable NWP. Compensatory mitigation is typically required for any impact that requires such notification. [Note: The Corps uses the Intermittent Channel Evaluation Form, located with Permit Information on the Regulatory Program Web Site, to aid in the determination of the intermittent channel stream status. Also, NWPs 13, 27 and 39 have specific reporting requirements.]

c. For all Nationwide Permits which allow the use of concrete as a building material, measures will be taken to prevent live or fresh concrete, including bags of uncured concrete, from coming into contact with waters of the state until the concrete has hardened.

d. For all Nationwide Permits that allow for the use of riprap material for bank stabilization, filter cloth must be placed underneath the riprap as an additional requirement of its use in North Carolina waters.

e. For all NWPs that involve the construction of culverts, measures will be included in the construction that will promote the safe passage of fish and other aquatic organisms. All culverts in the 20 CAMA coastal counties must be buried to a depth of one foot below the

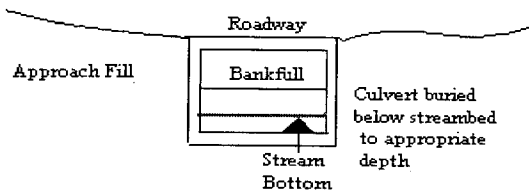

bed of the stream or wetland. For all culvert construction activities, the dimension, pattern, and profile of the stream, (above and below a pipe or culvert), should not be modified by widening the stream channel or by reducing the depth of the stream. Culvert inverts will be buried at least one foot below the bed of the stream for culverts greater than 48 inches in diameter. For culverts 48 inches in diameter or smaller, culverts must be buried below the bed of the stream to a depth equal to or greater than 20 percent of the diameter of the culvert. Bottomless arch culverts will satisfy this condition. A waiver from the depth specifications in this Regional Condition may be requested in writing. The waiver will only be issued if it can be demonstrated that the impacts of complying with this Regional Condition would result in more adverse impacts to the aquatic

environment.

3. Additional Regional Conditions Applicable to this Specific Nationwide Permit.

The required restoration plan must include a timetable for restoration activities.

NORTH CAROLINA DIVISION OF WATER QUALITY
GENERAL CERTIFICATION CONDITIONS

For the most recent General Certification conditions, call the NC Division of Water Quality, Wetlands/401 Certification Unit at (919) 733- 1786 or access the following website:

<http://h2o.enr.state.nc.us/ncwetlands/certs.html>

NORTH CAROLINA DIVISION OF COASTAL MANAGEMENT
STATE CONSISTENCY

Consistent.

Citations:

2002 Nationwide Permits - Federal Register Notice 15 Jan 2002

2002 Nationwide Permits Corrections - Federal Register Notice 13 Feb 2002

2002 Regional Conditions – Authorized 17 May 2002

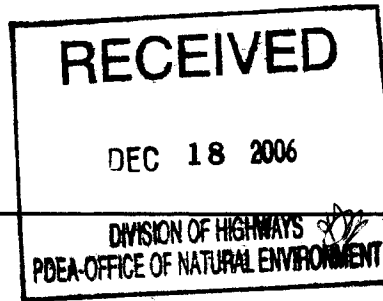

Michael F. Easley, Governor
 William G. Ross Jr., Secretary
 North Carolina Department of Environment and Natural Resources
 Alan W. Klimek, P.E. Director
 Division of Water Quality

Manley

December 12, 2006
 Mitchell Yancey Counties
 DWQ Project No. 04-0933
 Bridge No. 143 NCSR 1304
 TIP Project No. B-2848

APPROVAL of 401 Water Quality Certification with Additional Conditions

Dr. Gregory J. Thorpe, PhD., Director
 Project Development and Environmental Analysis
 North Carolina Department of Transportation
 1548 Mail Service Center
 Raleigh, North Carolina 27699-1548

Dear Dr. Thorpe:

You have our approval, in accordance with the attached conditions and those listed below, for the following impacts for the purpose of placing temporary and permanent fill material in the North Toe River while replacing bridge No. 143 in Mitchell/Yancey Counties:

Stream Impacts in the French Broad River Basin

Site	Permanent Fill in Intermittent Stream (linear ft)	Temporary Fill in Intermittent Stream (linear ft)	Permanent Fill in Perennial Stream (acres)	Temporary Fill in Perennial Stream (acres)	Total Stream Impact (acres)	Stream Impacts Requiring Mitigation (acres)
Site 1			<0.01	0.353	0.354	0
Total			<0.01	0.353	0.354	

Total Stream Impact for Project: 0.354 acres.

The project should be constructed in accordance with your application dated October 6, 2006, (received October 18, 2006), including the environmental commitments made in the application letters. After reviewing your application, we have decided that these impacts are covered by General Water Quality Certification Nos. 3403 and 3366. This Certification corresponds to Nationwide Permit Numbers 23 and 33 issued by the U.S. Army Corps of Engineers. In addition, you should acquire any other federal, state or local permits before you proceed with your project including (but not limited to) Sediment and Erosion Control, Non-Discharge and Water Supply Watershed regulations. This approval will expire with the accompanying 404 Permit.

This approval is valid solely for the purpose and design described in your application (unless modified below). Should your project change, you must notify the DWQ and submit a new application. If the property is sold, the new owner must be given a copy of this Certification and approval letter, and is thereby responsible for complying with all the conditions. If total wetland fills for this project (now or in the future) exceed one acre, or if total impacts to streams (now or in the future) exceed 150 linear feet, compensatory mitigation may be required as described in 15A NCAC 2H .0506 (h) (6) and (7). *For this approval to be valid, you must follow the conditions listed in the attached certification and any additional conditions listed below.*



1. Erosion and sediment control practices must be in full compliance with all specifications governing the proper design, installation and operation and maintenance of such Best Management Practices in order to protect surface waters standards:
 - a. The erosion and sediment control measures for the project must be designed, installed, operated, and maintained in accordance with the most recent version of the *North Carolina Sediment and Erosion Control Planning and Design Manual*.
 - b. The design, installation, operation, and maintenance of the sediment and erosion control measures must be such that they equal, or exceed, the requirements specified in the most recent version of the *North Carolina Sediment and Erosion Control Manual*. The devices shall be maintained on all construction sites, borrow sites, and waste pile (spoil) projects, including contractor-owned or leased borrow pits associated with the project.
 - c. For borrow pit sites, the erosion and sediment control measures must be designed, installed, operated, and maintained in accordance with the most recent version of the *North Carolina Surface Mining Manual*.
 - d. The reclamation measures and implementation must comply with the reclamation in accordance with the requirements of the Sedimentation Pollution Control Act.
2. There shall be no excavation from or waste disposal into, jurisdictional wetlands or waters associated with this permit without appropriate modification. Should waste or borrow sites be located in wetlands or streams, compensatory mitigation will be required since that is a direct impact from road construction activities.
3. Sediment and erosion control measures shall not be placed in wetlands or waters unless otherwise approved by this Certification. If placement of sediment and erosion control devices in wetlands and waters is unavoidable, they shall be removed and the natural grade restored upon completion of the project.
4. The permittee shall use *Design Standards in Sensitive Watersheds* [15A NCAC 4B.0124 (a)-(e)]. Temporary cover (wheat, millet or similar annual grain) or permanent herbaceous cover should be planted on all bare soil within fifteen (15) days of ground disturbing activities to provide long-term erosion control. Erosion control matting should be used in conjunction with appropriate seeding on disturbed soils in steep slope and riparian areas. Matting should be secured in place with staples or wherever possible, live stakes of native trees. Straw mulch and tall fescue should **not** be used in riparian areas.
5. Strict adherence to the most recent version of NCDOT's Best Management Practice For Bridge Demolition and Removal, approved by the US Army Corps of Engineers, is a condition of the 401 Water Quality Certification.
6. Bridge deck drains should not discharge directly into streams. Stormwater should be directed across the bridge and pre-treated through site-appropriate means (grass swales, pre-formed scour holes, vegetated buffers, etc.) before entering the stream. Please refer to the most current version of *Stormwater Best Management Practices*.
7. All work in or adjacent to stream waters shall be conducted in a dry work area. Approved BMP measures from the most current version of NCDOT Construction and Maintenance Activities manual such as sandbags, rock berms, cofferdams and other diversion structures should be used to prevent excavation in flowing water.
8. For projects impacting waters classified by the NC Environmental Management Commission as Trout (Tr), High Quality Waters (HQW) or Water Supply I or II (WS-I, WS-II), stormwater shall be directed to vegetated buffer areas, grass-lined ditches or other means appropriate to the site for the purpose of pre-treating stormwater runoff prior to discharging directly into streams. Mowing of existing vegetated buffer areas is strongly discouraged.
9. Only clean and sediment free riprap shall be used and placed in surface waters.
10. The post-construction removal of temporary work pads will need to return the project site to its preconstruction contours and elevations. The impacted areas shall be revegetated with appropriate native species. Disturbed floodplains and streams should be restored to natural geomorphic conditions.
11. Mussels located in the North Toe River shall be relocated from the proposed impact area, prior to installing in-stream structures, in accordance with the North Carolina Wildlife Resources Commission recommendations.
12. The existing roadway that is to be eliminated should be restored back to original ground elevations and the natural floodplain elevations and functions restored. Disturbed areas should be seeded or mulched to stabilize the soil and native tree species should be planted with spacing of not more than 10ft. x 10ft.
13. Native riparian vegetation (e.g. rhododendron, dog hobble, willows, alders, sycamores, dogwoods, black walnut and red maple) must be reestablished within the construction limits of the project by the end of the growing season following completion of construction.

Dr. Gregory J. Thorpe, PhD.

December 12, 2006

Page Three

14. Any riprap placed for bank stabilization should be limited to the streambank below the high water mark, and vegetation should be used for stabilization above the high water elevation. Riprap should not be placed in the active thalweg channel or placed in the streambed in such a manner that precludes aquatic life passage. Bioengineering boulders or structures should be properly designed, sized and installed.
15. Heavy equipment should be operated from the banks rather than in the stream channels in order to minimize sedimentation and reduce the introduction of other pollutants into the stream.
16. All mechanized equipment operated near surface waters must be regularly inspected daily and maintained to prevent contamination of stream waters from fuels, lubricants, hydraulic fluids, or other toxic materials.
17. Discharging hydroseed mixtures and washing out hydroseeders and other equipment in or adjacent to surface waters is prohibited.
18. If concrete is used during construction (e.g., headwalls), a dry work area should be maintained to prevent direct contact between curing concrete and stream water. Water that inadvertently contacts uncured concrete should not be discharged to surface waters due to the potential for elevated pH and possible aquatic life and fish kills.
19. No rock, sand or other materials shall be dredged from the stream channel, except where authorized by this certification.
20. A copy of this Water Quality Certification shall be posted on the construction site at all times. In addition, the Water Quality Certification and all subsequent modifications, if any, shall be maintained with the Division Engineer and the on-site project manager.
21. The permittee and its authorized agents shall conduct its activities in a manner consistent with State water other appropriate requirements of State or Federal law. If DWQ determines that such standards or laws are not being met (including failure to sustain a designated achieved use) or that State or Federal law is being violated, or that further conditions are necessary to assure compliance, DWQ may reevaluate and modify this certification.
22. During the construction of the project, no staging of equipment of any kind is permitted in waters of the U.S. or protected riparian buffers.
23. Upon completion of the project, the NCDOT Division Engineer, shall complete and return the enclosed "Certificate of Completion Form" to notify NCDWQ when all work included in the §401 Certification has been completed. This form shall be returned to the Transportation Permitting Unit of the NC Division of Water Quality, 2321 Crabtree Blvd., Suite 250, Raleigh, North Carolina 27604.

If you do not accept any of the conditions of this certification, you may ask for an adjudicatory hearing. You must act within 60 days of the date that you receive this letter. To ask for a hearing, send a written petition, which conforms to Chapter 150B of the North Carolina General Statutes to the Office of Administrative Hearings, 6714 Mail Service Center, Raleigh, N.C. 27699-6714. This certification and its conditions are final and binding unless you ask for a hearing.

This letter completes the review of the Division of Water Quality under Section 401 of the Clean Water Act. If you have any questions, please telephone Mr. Mike Parker of the Asheville Regional Office at 828.296.4500.

Sincerely,



 Alan W. Klimek, P.E., Director
Division of Water Quality

cc: Mr. J.J. Swain, P.E. Division 13 Engineer
Mr. Roger Bryan, Division 13 Environmental Officer
David Baker, USACE Asheville Field Office
Transportation Permitting Unit
Mike Parker, Asheville Regional Office

WQC #3366

GENERAL CERTIFICATION FOR PROJECTS ELIGIBLE FOR CORPS OF ENGINEERS NATIONWIDE PERMIT NUMBER 33 (TEMPORARY CONSTRUCTION, ACCESS AND DEWATERING) AND RIPARIAN AREA PROTECTION RULES (BUFFER RULES)

This General Certification is issued in conformity with the requirements of Section 401, Public Laws 92-500 and 95-217 of the United States and subject to the North Carolina Division of Water Quality Regulations in 15A NCAC 2H, Section .0500 and 15A NCAC 2B .0200 for the discharge of fill material to waters and wetland areas as described in 33 CFR 330 Appendix A (B) (33) of the Corps of Engineers regulations (i.e., Nationwide Permit No. 33) and for the Riparian Area Protection Rules (Buffer Rules) in 15A NCAC 2B .0200. The category of activities shall include any fill activity for temporary construction, access and de-watering. This Certification replaces Water Quality Certification Number 2727 issued on May 1, 1992 and Certification Number 3114 issued on February 11, 1997. This WQC is rescinded when the Corps of Engineers reauthorize Nationwide Permit 33 or when deemed appropriate by the Director of the DWQ.

The State of North Carolina certifies that the specified category of activity will not violate appropriate portions of Sections 301, 302, 303, 306 and 307 of the Public Laws 92-500 and 95-217 if conducted in accordance with the conditions hereinafter set forth.

Conditions of Certification:

1. These activities do not require written concurrence from the Division of Water Quality as long as they comply with all conditions of this General Certification. If any condition in this Certification cannot be met, application to and written concurrence from DWQ are required. Also, Condition No. 2 is applicable to all streams in basins with riparian area protection rules;
2. Impacts to any stream length in the Neuse, Tar-Pamlico and Randleman River Basins (or any other major river basins with Riparian Area Protection Rules [Buffer Rules] in effect at the time of application) requires written concurrence from DWQ in accordance with 15A NCAC 2B.0200. Activities listed as "exempt" from these rules do not need to apply for written concurrence under this Certification. New development activities located in the protected 50-foot wide riparian areas (whether jurisdictional wetlands or not) within the Neuse, Tar-Pamlico, Randleman and Catawba River Basins shall be limited to "uses" identified within and constructed in accordance with 15A NCAC 2B .0200. All new development shall be located, designed, constructed, and maintained to have minimal disturbance to protect water quality to the maximum extent practicable through the use of best management practices;
3. Appropriate sediment and erosion control practices which equal or exceed those outlined in the most recent version of the "North Carolina Sediment and Erosion Control Planning and Design Manual" or the "North Carolina Surface Mining Manual" whichever is more appropriate (available from the Division of Land Resources (DLR) in the DENR Regional or Central Offices) shall be in full compliance with all specifications governing the proper design, installation and operation and maintenance of such Best Management Practices in order to assure compliance with the appropriate turbidity water quality standard;

WQC #3366

4. All sediment and erosion control measures placed in wetlands or waters shall be removed and the original grade restored within two months after the Division of Land Resources has released the project;
5. If an environmental document is required, this Certification is not valid until a Finding of No Significant Impact (FONSI) or Record of Decision (ROD) is issued by the State Clearinghouse;
6. Placement of culverts and other structures in waters, streams, and wetlands must be placed below the elevation of the streambed to allow low flow passage of water and aquatic life unless it can be shown to DWQ that providing passage would be impractical. Design and placement of culverts including open bottom or bottomless arch culverts and other structures including temporary erosion control measures shall not be conducted in a manner that may result in aggradation, degradation or significant changes in hydrology of wetlands or stream beds or banks, adjacent to or upstream and down stream of the above structures. The applicant is required to provide evidence that the equilibrium shall be maintained if requested in writing by DWQ. Additionally, when roadways, causeways or other fill projects are constructed across FEMA-designated floodways or wetlands, openings such as culverts or bridges must be provided to maintain the natural hydrology of the system as well as prevent constriction of the floodway that may result in aggradation, degradation or significant changes in hydrology of streams or wetlands;
7. Measures shall be taken to prevent live or fresh concrete from coming into contact with waters of the state until the concrete has hardened;
8. All temporary fill shall be removed to the original grade after construction is complete and the site shall be stabilized to prevent erosion;
9. Pipes shall be installed under the road or causeway in all streams to carry at least the 25 year storm event as outlined in the most recent edition of the "North Carolina Sediment and Erosion Control Planning and Design Manual" or the "North Carolina Surface Mining Manual" so as not to restrict stream flow during use of this Certification;
10. In accordance with North Carolina General Statute Section 143-215.3D(e), any request for written concurrence for a 401 Water Quality Certification must include the appropriate fee. If a project also requires a CAMA Permit, one payment to both agencies shall be submitted and will be the higher of the two fees;
11. Additional site-specific conditions may be added to projects for which written concurrence is required or requested under this Certification in order to ensure compliance with all applicable water quality and effluent standards;
12. Concurrence from DWQ that this Certification applies to an individual project shall expire three years from the date of the cover letter from DWQ or on the same day as the expiration date of these corresponding Nationwide and Regional General Permits, whichever is sooner;

WQC #3366

13. When written concurrence is required, the applicant is required to use the most recent version of the Certification of Completion form to notify DWQ when all work included in the 401 Certification has been completed.

Non-compliance with or violation of the conditions herein set forth by a specific fill project shall result in revocation of this Certification for the project and may result in criminal and/or civil penalties.

The Director of the North Carolina Division of Water Quality may require submission of a formal application for individual certification for any project in this category of activity that requires written concurrence under this certification, if it is determined that the project is likely to have a significant adverse effect upon water quality or degrade the waters so that existing uses of the wetland, stream or downstream waters are precluded.

Public hearings may be held for specific applications or group of applications prior to a Certification decision if deemed in the public's best interest by the Director of the North Carolina Division of Water Quality.

Effective date: 18 March 2002

DIVISION OF WATER QUALITY

By

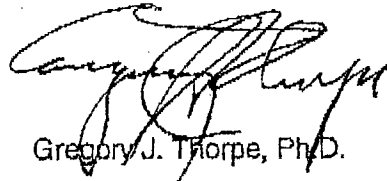

Gregory J. Thorpe, Ph.D.

Acting Director

WQC # 3366

WQC #3403

GENERAL CERTIFICATION FOR PROJECTS ELIGIBLE FOR CORPS OF ENGINEERS NATIONWIDE PERMIT NUMBER 23 (APPROVED CATEGORICAL EXCLUSIONS) AND RIPARIAN AREA PROTECTION RULES (BUFFER RULES)

This General Certification is issued in conformity with the requirements of Section 401, Public Laws 92-500 and 95-217 of the United States and subject to the North Carolina Division of Water Quality Regulations in 15A NCAC 2H, Section .0500 and 15A NCAC 2B .0200 for the discharge of fill material to waters and wetland areas as described in 33 CFR 330 Appendix A (B) (23) and for the Riparian Area Protection Rules (Buffer Rules) in 15A NCAC 2B .0200. This Certification replaces Water Quality Certification Number 2670 issued on January 21, 1992, Certification Number 2734 issued on May 1 1993, Certification Number 3107 issued on February 11, 1997 and Water Quality Certification Number 3361 issued March 18, 2002. This WQC is rescinded when the Corps of Engineers re-authorizes Nationwide Permit 23 or when deemed appropriate by the Director of the DWQ.

The State of North Carolina certifies that the specified category of activity will not violate applicable portions of Sections 301, 302, 303, 306 and 307 of the Public Laws 92-500 and 95-217 if conducted in accordance with the conditions hereinafter set forth.

Conditions of Certification:

1. Proposed fill or substantial modification of wetlands or waters (including streams) under this General Certification requires notification to the Division of Water Quality. Two copies shall be submitted to DWQ at the time of notification in accordance with 15A NCAC 2H .0501(a). Written concurrence from DWQ is not required unless any standard conditions of this Certification cannot be met;
2. Appropriate sediment and erosion control practices which equal or exceed those outlined in the most recent version of the "North Carolina Sediment and Erosion Control Planning and Design Manual" or the "North Carolina Surface Mining Manual" whichever is more appropriate (available from the Division of Land Resources (DLR) in the DENR Regional or Central Offices) shall be in full compliance with all specifications governing the proper design, installation and operation and maintenance of such Best Management Practices in order to assure compliance with the appropriate turbidity water quality standard;
3. In accordance with 15A NCAC 2H .0506 (h) compensatory mitigation may be required for impacts to 150 linear feet or more of streams and/or one acre or more of wetlands. In addition, buffer mitigation may be required for any project with Buffer Rules in effect at the time of application for buffer impacts resulting from activities classified as "allowable with mitigation" within the "Table of Uses" section of the Buffer Rules or require a variance under the Buffer Rules. A determination of buffer, wetland and stream mitigation requirements shall be made for any Certification for this Nationwide Permit. The most current design and monitoring protocols from DWQ shall be followed and written plans submitted for DWQ approval as required in those protocols. When compensatory mitigation is required for a project, the mitigation plans must be approved by DWQ in writing before the impacts approved by the Certification occur. The mitigation plan must be implemented and/or constructed before any permanent building or structure on

WQC #3403

site is occupied. In the case of public road projects, the mitigation plan must be implemented before the road is opened to the travelling public;

4. Compensatory stream mitigation shall be required at a 1:1 ratio for not only perennial but also intermittent stream impacts equal to or exceeding 150 feet and that require application to DWQ in watersheds classified as ORW, HQW, Tr, WS-I and WS-II unless the project is a linear, publicly-funded transportation project, which has a 150-foot per-stream impact allowance;
5. All sediment and erosion control measures placed in wetlands or waters shall be removed and the original grade restored within two months after the Division of Land Resources has released the project;
6. Measures shall be taken to prevent live or fresh concrete from coming into contact with freshwaters of the state until the concrete has hardened;
7. In accordance with North Carolina General Statute Section 143-215.3D(e), any request for written concurrence for a 401 Water Quality Certification must include the appropriate fee. If a project also requires a CAMA Permit, one payment to both agencies shall be submitted and will be the higher of the two fees;
8. Impacts to any stream length in the Neuse, Tar-Pamlico, Randleman and Catawba River Basins (or any other river basins with Riparian Area Protection Rules [Buffer Rules] in effect at the time of application) requires written concurrence from DWQ in accordance with 15A NCAC 2B.0200. Activities listed as "exempt" from these rules do not need to apply for written concurrence under this Certification. New development activities located in the protected 50-foot wide riparian areas (whether jurisdictional wetlands or not) within the Neuse, Tar-Pamlico, Randleman and Catawba River Basins shall be limited to "uses" identified within and constructed in accordance with 15A NCAC 2B .0200. All new development shall be located, designed, constructed, and maintained to have minimal disturbance to protect water quality to the maximum extent practicable through the use of best management practices;
9. Additional site-specific conditions may be added to projects for which written concurrence is required or requested under this Certification in order to ensure compliance with all applicable water quality and effluent standards;
10. Concurrence from DWQ that this Certification applies to an individual project shall expire three years from the date of the cover letter from DWQ or on the same day as the expiration date of the corresponding Nationwide and Regional General Permits, whichever is sooner;
11. When written concurrence is required, the applicant is required to use the most recent version of the Certification of Completion form to notify DWQ when all work included in the 401 Certification has been completed.

Non-compliance with or violation of the conditions herein set forth by a specific fill project shall result in revocation of this Certification for the project and may result in criminal and/or civil penalties.

WQC #3403

The Director of the North Carolina Division of Water Quality may require submission of a formal application for individual certification for any project in this category of activity that requires written concurrence under this certification, if it is determined that the project is likely to have a significant adverse effect upon water quality or degrade the waters so that existing uses of the wetland, stream or downstream waters are precluded.

Public hearings may be held for specific applications or group of applications prior to a Certification decision if deemed in the public's best interest by the Director of the North Carolina Division of Water Quality.

Effective date: 28 March 2003

DIVISION OF WATER QUALITY

By

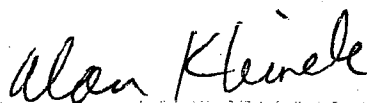

Alan W. Klimek, P.E.

Director

WQC # 3403

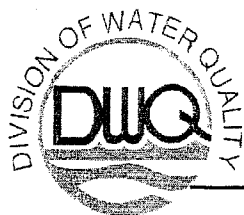

DWQ Project No.: _____ County: _____

Applicant: _____

Project Name: _____

Date of Issuance of 401 Water Quality Certification: _____

Certificate of Completion

Upon completion of all work approved within the 401 Water Quality Certification or applicable Buffer Rules, and any subsequent modifications, the applicant is required to return this certificate to the 401 Transportation Permitting Unit, North Carolina Division of Water Quality, 1650 Mail Service Center, Raleigh, NC, 27699-1650. This form may be returned to DWQ by the applicant, the applicant's authorized agent, or the project engineer. It is not necessary to send certificates from all of these.

Applicant's Certification

I, _____, hereby state that, to the best of my abilities, due care and diligence was used in the observation of the construction such that the construction was observed to be built within substantial compliance and intent of the 401 Water Quality Certification and Buffer Rules, the approved plans and specifications, and other supporting materials.

Signature: _____ Date: _____

Agent's Certification

I, _____, hereby state that, to the best of my abilities, due care and diligence was used in the observation of the construction such that the construction was observed to be built within substantial compliance and intent of the 401 Water Quality Certification and Buffer Rules, the approved plans and specifications, and other supporting materials.

Signature: _____ Date: _____

Engineer's Certification

_____ Partial _____ Final

I, _____, as a duly registered Professional Engineer in the State of North Carolina, having been authorized to observe (periodically, weekly, full time) the construction of the project, for the Permittee hereby state that, to the best of my abilities, due care and diligence was used in the observation of the construction such that the construction was observed to be built within substantial compliance and intent of the 401 Water Quality Certification and Buffer Rules, the approved plans and specifications, and other supporting materials.

Signature _____ Registration No. _____

Date _____

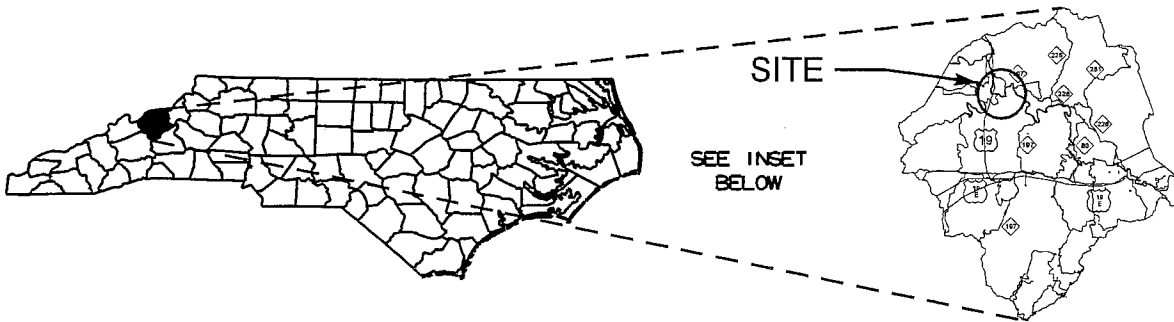

MITCHELL/YANCEY COUNTY

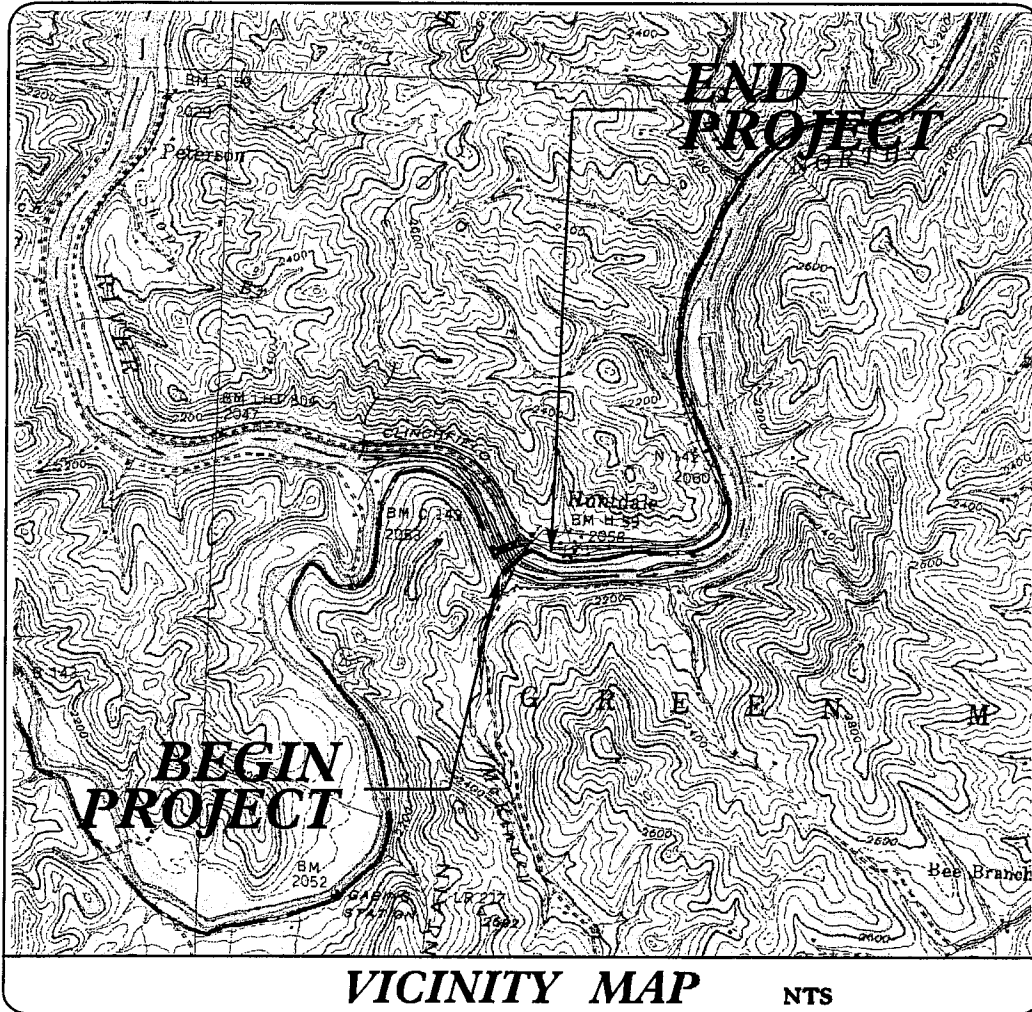

N.C. DEPT. OF TRANSPORTATION
 DIVISION OF HIGHWAYS

MITCHELL/YANCEY COUNTY
 PROJECT: 8.2880401 (B-2848)
 BRIDGE NO. 143 ON SR 1304
 OVER NORTH TOE RIVER

SHEET ____ OF ____ 8/15/06

WORKPAD DETAIL (NOT TO SCALE)

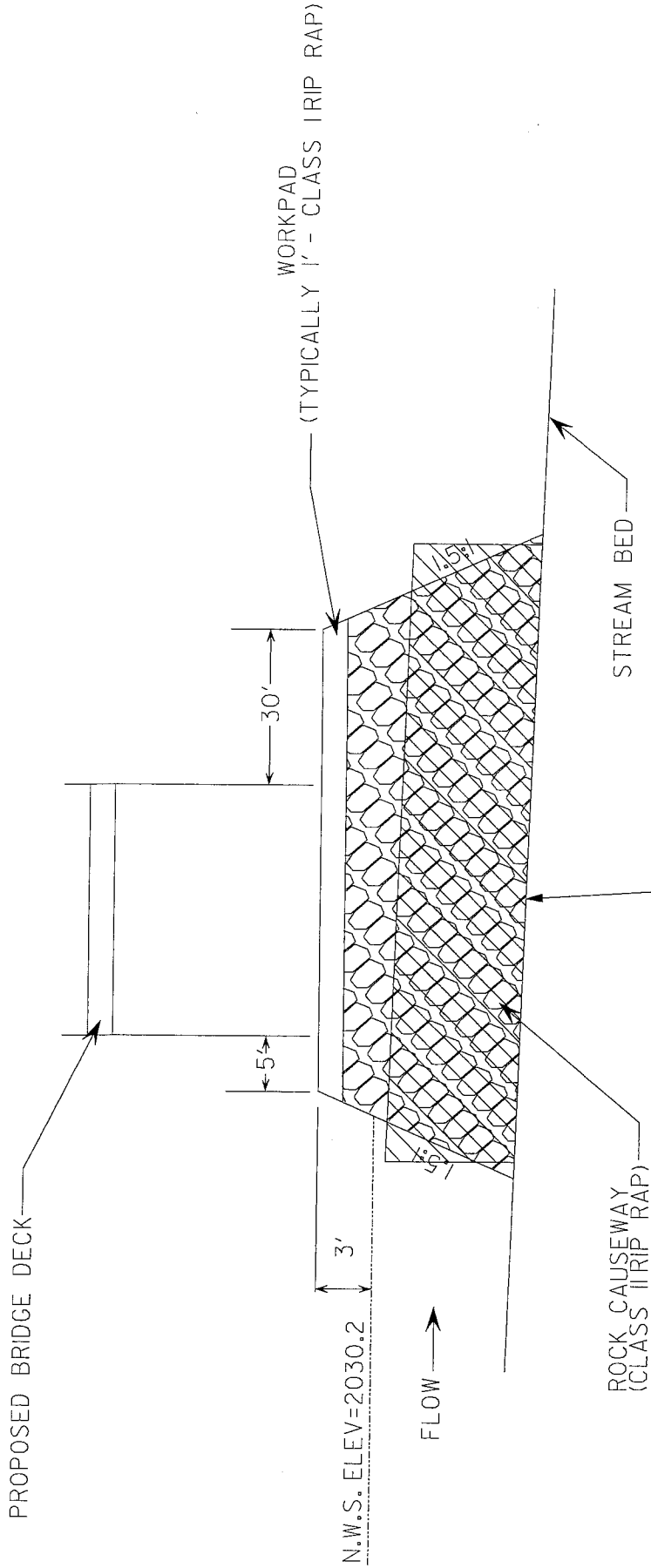

NC DOT

DIVISION OF HIGHWAYS
MITCHELL / YANCEY COUNTY
PROJECT: 8.2880401 (B-2848)
BRIDGE #143 ON SR 1304
OVER NORTH TOE RIVER

SHEET OF REV 04/8/04

QUANTITIES OF ESTIMATES

VOLUME OF CLASS II RIP RAP= 2175 yds³
AREA OF CLASS II RIP RAP= 0.398 ac
Estimate 2480 Tons Class II Rip Rap

WETLAND PERMIT IMPACT SUMMARY

Site No.	Station (From/To)	Structure Size / Type	WETLAND IMPACTS							SURFACE WATER IMPACTS			
			Fill In Wetlands (ac)	Temp. Fill In Wetlands (ac)	Excavation In Wetlands (ac)	Mechanized Clearing (Method III) (ac)	Fill In SW (Natural) (ac)	Fill In SW (Pond) (ac)	Temp. Fill In SW (ac)	Existing Channel Impacted (ft)	Natural Stream Design (ft)		
1	11+97.50 -L-	TEMP BRIDGE WORKPAD									0.353		
TOTALS:			0	0	0	0	0	0	0	0	0.353	0	0

NC DEPARTMENT OF TRANSPORTATION
 DIVISION OF HIGHWAYS
 YANCEY/MITCHELL COUNTY
 PROJECT 8.2880401 B-2848

SHEET OF REV. 8/18/2006

DATUM DESCRIPTION
 THE LOCALIZED COORDINATE SYSTEM DEVELOPED FOR THIS PROJECT IS BASED ON THE STATE PLANE COORDINATES ESTABLISHED BY NCGS FOR MONUMENT "HUNTDAL" WITH NAD 1983/95 STATE PLANE GRID COORDINATES OF NORTHING: 84486.890(1) EASTING: 1019080.400(1) THE AVERAGE COMBINED GRID FACTOR USED ON THIS PROJECT (GROUND TO GRID) IS: 0.9990557 THE N.C. LAMBERT GRID BEARING AND LOCALIZED HORIZONTAL GROUND DISTANCE FROM "HUNTDAL" TO -L- STATION 10+00.00 IS S 85° 39' 48.1" W 1,105.69' ALL LINEAR DIMENSIONS ARE LOCALIZED HORIZONTAL DISTANCES VERTICAL DATUM USED IS NAVD 88

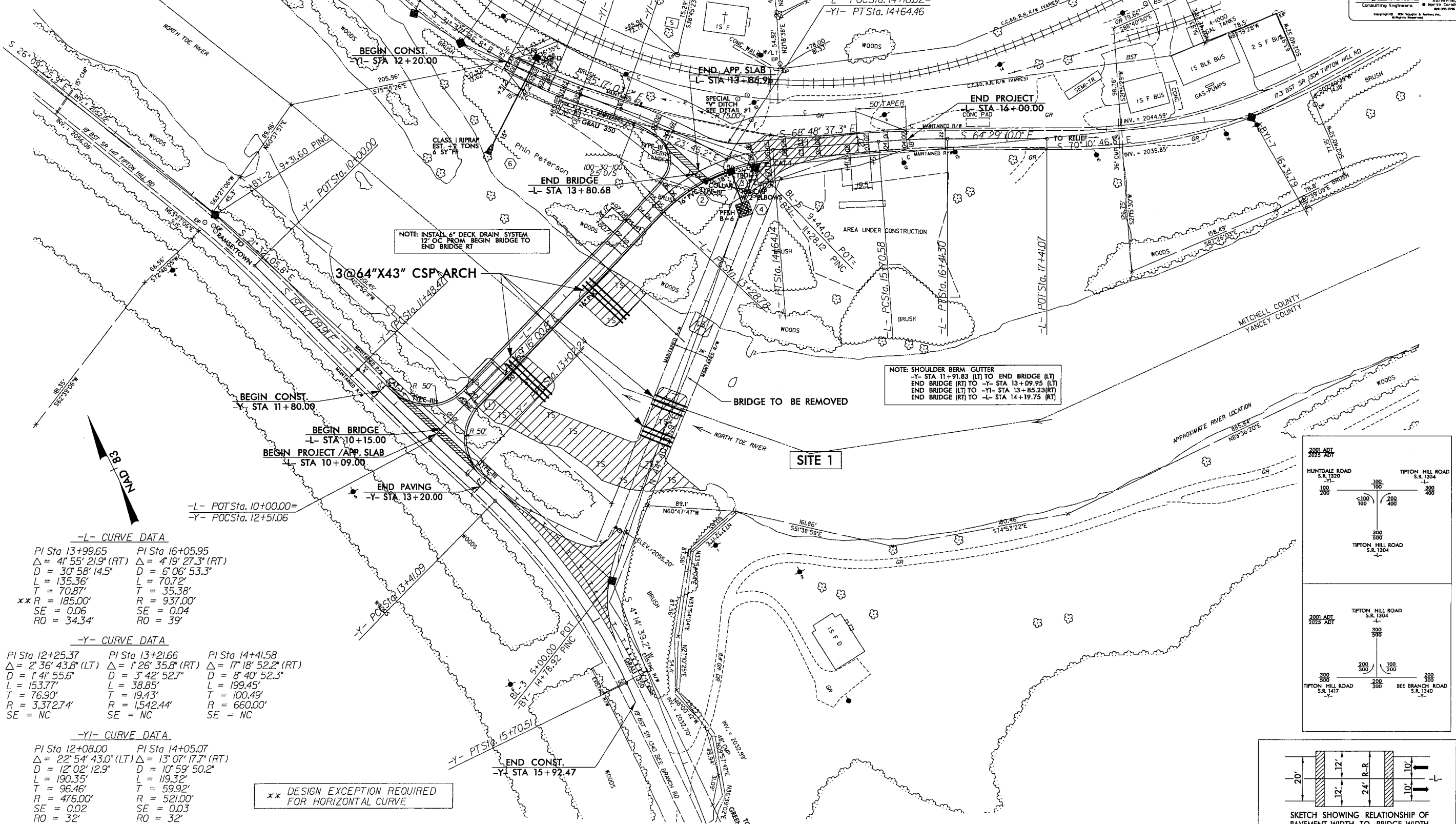
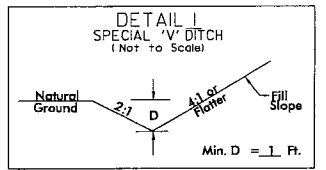

-L- CURVE DATA

PI Sta 13+99.65	PI Sta 16+05.95
$\Delta = 41' 55'' 21.9''$ (RT)	$\Delta = 4' 19'' 27.3''$ (RT)
D = 30' 58'' 14.5''	D = 6' 06'' 53.3''
L = 135.36'	L = 70.72'
T = 70.87'	T = 35.38'
**R = 185.00'	R = 937.00'
SE = 0.06	SE = 0.04
RO = 34.34'	RO = 39'

-Y- CURVE DATA

PI Sta 12+25.37	PI Sta 13+21.66	PI Sta 14+41.58
$\Delta = 2' 36'' 43.8''$ (LT)	$\Delta = 1' 26'' 35.8''$ (RT)	$\Delta = 17' 18'' 52.2''$ (RT)
D = 1' 41'' 55.6''	D = 3' 42'' 52.7''	D = 8' 40'' 52.3''
L = 153.77'	L = 38.85'	L = 199.45'
T = 76.90'	T = 19.43'	T = 100.49'
R = 3,372.74'	R = 1,542.44'	R = 660.00'
SE = NC	SE = NC	SE = NC

-YI- CURVE DATA

PI Sta 12+08.00	PI Sta 14+05.07
$\Delta = 22' 54'' 43.0''$ (LT)	$\Delta = 13' 07'' 17.7''$ (RT)
D = 12' 02'' 12.9''	D = 10' 59'' 50.2''
L = 190.35'	L = 119.32'
T = 96.46'	T = 59.92'
R = 476.00'	R = 521.00'
SE = 0.02	SE = 0.03
RO = 32'	RO = 32'

** DESIGN EXCEPTION REQUIRED FOR HORIZONTAL CURVE

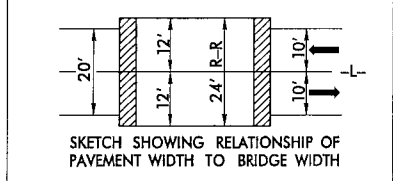
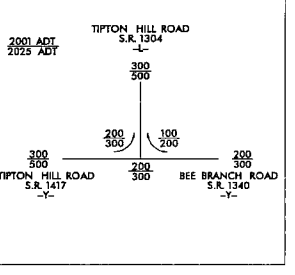
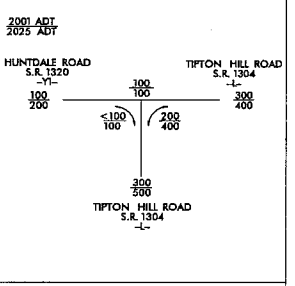

SEE SHEETS 5 & 6 FOR PROFILES

B-17/99

REVISIONS

*****SYTIME*****
 *****DESIGN*****
 *****CHECK*****
 *****DATE*****

PROJECT REFERENCE NO. B-2648	SHEET NO. 1
RW SHEET NO.	
ROADWAY DESIGN ENGINEER	HYDRAULICS ENGINEER
INCOMPLETE PLANS DO NOT USE FOR R/W ACQUISITION PRELIMINARY PLANS DO NOT USE FOR CONSTRUCTION	



DATUM DESCRIPTION
 THE LOCALIZED COORDINATE SYSTEM DEVELOPED FOR THIS PROJECT IS BASED ON THE STATE PLANE COORDINATES ESTABLISHED BY MDS FOR MONUMENT "HUNTDAL".
 WITH NAD 1983/95 STATE PLANE GRID COORDINATES OF NORTHINGS: 844866.800(1) EASTINGS: 1019088.400(1)
 THE AVERAGE COMBINED GRID FACTOR USED ON THIS PROJECT (GROUND TO GRID) IS: 0.99905557
 THE N.C. LAMBERT GRID BEARING AND LOCALIZED HORIZONTAL GROUND DISTANCE FROM "HUNTDAL" TO L- STA 10+00.00 IS
 S 85° 39' 48.1" W 4.10569'
 ALL LINEAR DIMENSIONS ARE LOCALIZED HORIZONTAL DISTANCES
 VERTICAL DATUM USED IS NAD 88

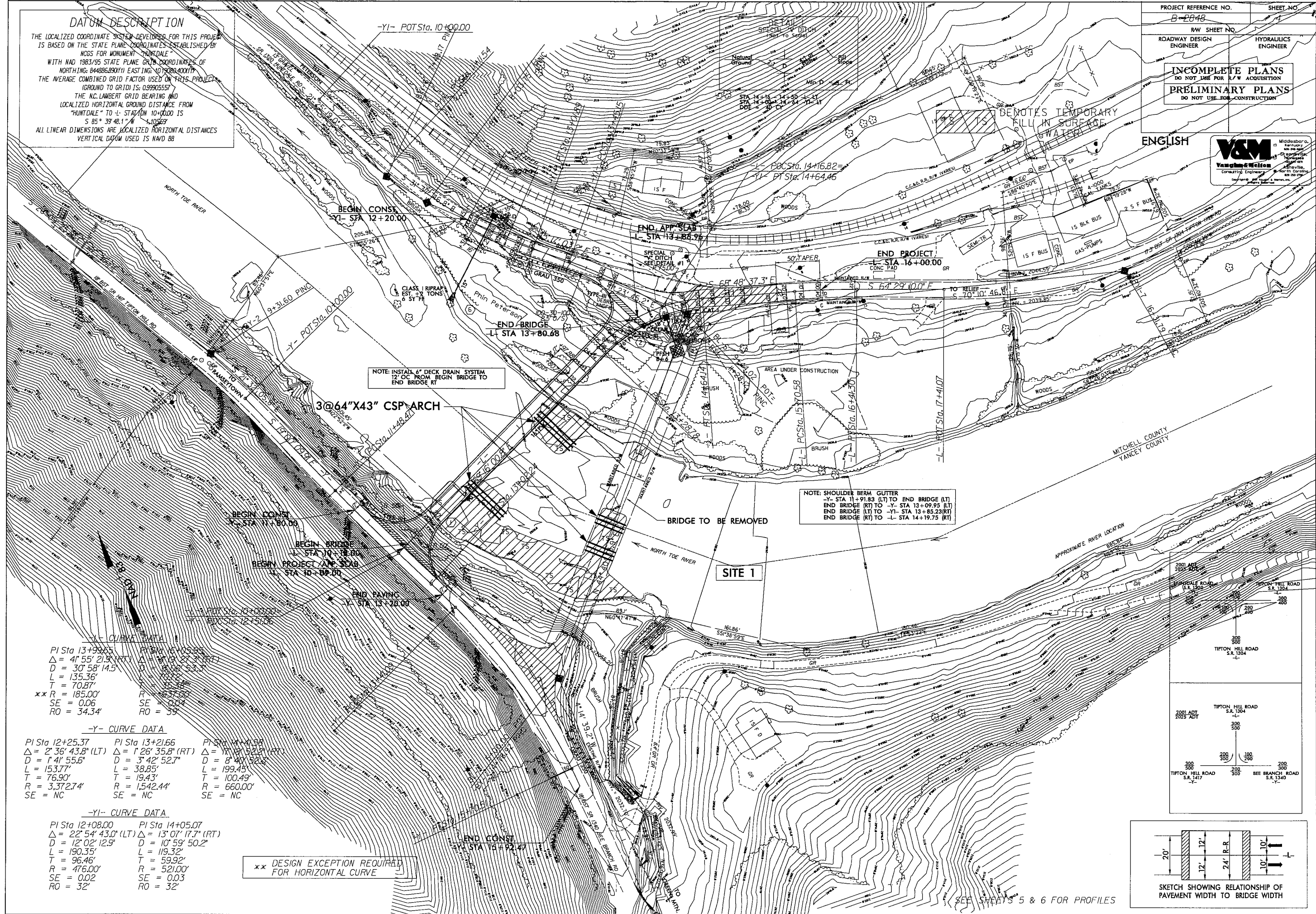

-X- CURVE DATA

PI Sta 13+99.65	PI Sta 12+05.89
$\Delta = 41' 55" 21.9'$ (RT)	$\Delta = 41' 19" 27.3'$ (RT)
D = 30' 58" 14.5'	D = 26' 06" 53.3'
L = 135.36'	L = 107.50'
T = 70.87'	T = 57.50'
** R = 185.00'	R = 137.00'
SE = 0.06	SE = 0.04
RO = 34.34'	RO = 39'

-Y- CURVE DATA

PI Sta 12+25.37	PI Sta 13+21.66	PI Sta 14+41.98
$\Delta = 2' 36" 43.8'$ (LT)	$\Delta = 1' 26" 35.8'$ (RT)	$\Delta = 11' 18" 52.1'$ (RT)
D = 1' 41" 55.6"	D = 3' 42" 52.7"	D = 8' 40" 52.3"
L = 153.77'	L = 38.85'	L = 199.45'
T = 76.90'	T = 19.43'	T = 100.49'
R = 3,372.74'	R = 1,542.44'	R = 660.00'
SE = NC	SE = NC	SE = NC

-YI- CURVE DATA

PI Sta 12+08.00	PI Sta 14+05.07
$\Delta = 22' 54" 43.0'$ (LT)	$\Delta = 13' 07" 17.7'$ (RT)
D = 12' 02" 12.9"	D = 10' 59" 50.2"
L = 190.35'	L = 119.32'
T = 96.46'	T = 59.92'
R = 476.00'	R = 521.00'
SE = 0.02	SE = 0.03
RO = 32'	RO = 32'

** DESIGN EXCEPTION REQUIRED FOR HORIZONTAL CURVE

NOTE: SHOULDER BERM GUTTER
 -Y- STA 11+91.83 (LT) TO END BRIDGE (LT)
 END BRIDGE (RT) TO -Y- STA 13+09.95 (LT)
 END BRIDGE (LT) TO -YI- STA 13+85.23 (RT)
 END BRIDGE (RT) TO -L- STA 14+19.75 (RT)

NOTE: INSTALL 6" DECK DRAIN SYSTEM
 12' OC FROM BEGIN BRIDGE TO
 END BRIDGE RT

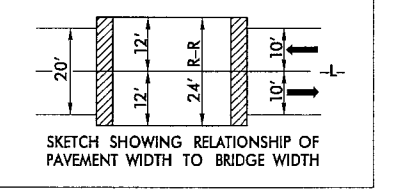
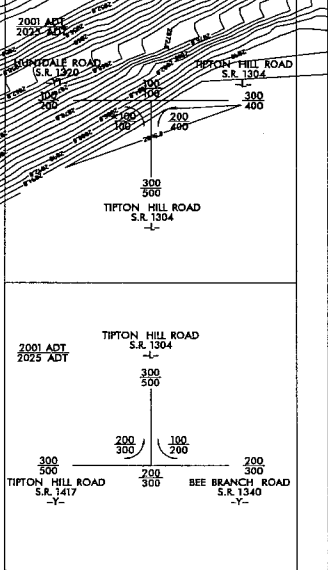

SEE SHEETS 5 & 6 FOR PROFILES

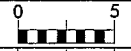

70 60 50 40 30 20 10 0 10 20 30 40 50 60 70

SITE 1

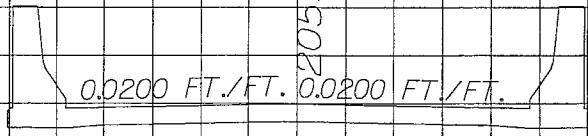

2059.97

0.0200 FT./FT. 0.0200 FT./FT.

2033.43
10+50.00

2060.53
10+00.00

\$\$\$\$\$SYTIME\$\$\$\$\$

\$\$\$\$\$SERIAL\$\$\$\$\$
#####

INCOMPLETE PLANS
DO NOT USE FOR R/W ACQUISITION

70 60 50 40 30 20 10 0 10 20 30 40 50 60 70

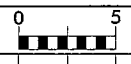

70 60 50 40 30 20 10 0 10 20 30 40 50 60 70

SITE 1

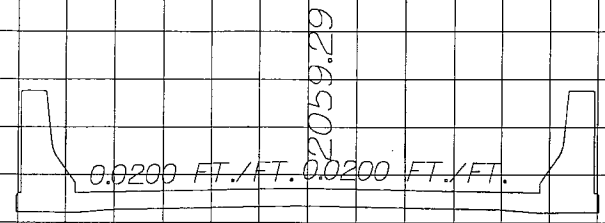

TEMP FILL IN SURFACE WATER

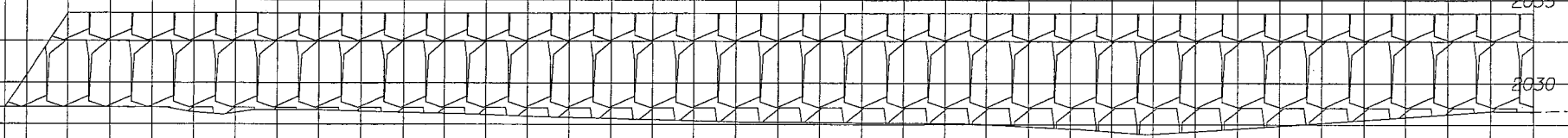

2028.36
11700.00

70 60 50 40 30 20 10 0 10 20 30 40 50 60 70

SYSTEMS TIME
RESERVE

8/23/99

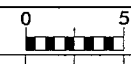

PROJ. REFERENCE NO.
B-2848

SHEET NO.
X-4

70 60 50 40 30 20 10 0 10 20 30 40 50 60 70

SITE 1

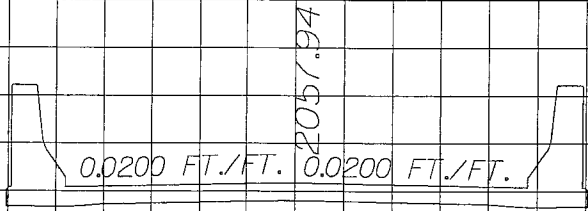

0.0200 FT./FT. 0.0200 FT./FT.

2057.94

2028.37
12+00.00

2065
2060
2055
2050
2045
2040
2035
2030
2025

2065
2060
2055
2050
2045
2040
2035
2030
2025

70 60 50 40 30 20 10 0 10 20 30 40 50 60 70

\$\$\$\$\$SYTIME\$\$\$\$\$
\$\$\$\$\$DODON\$\$\$\$\$
\$\$\$\$\$SERNAME\$\$\$\$\$

8/23/99
SYSTEMS
USE RAINAGE



PROJ. REFERENCE NO.
B-2848

SHEET NO.
X-5

70 60 50 40 30 20 10 0 10 20 30 40 50 60 70

SITE 1

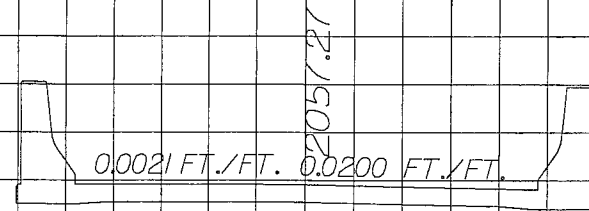

← TEMP FILL IN SURFACE WATER →

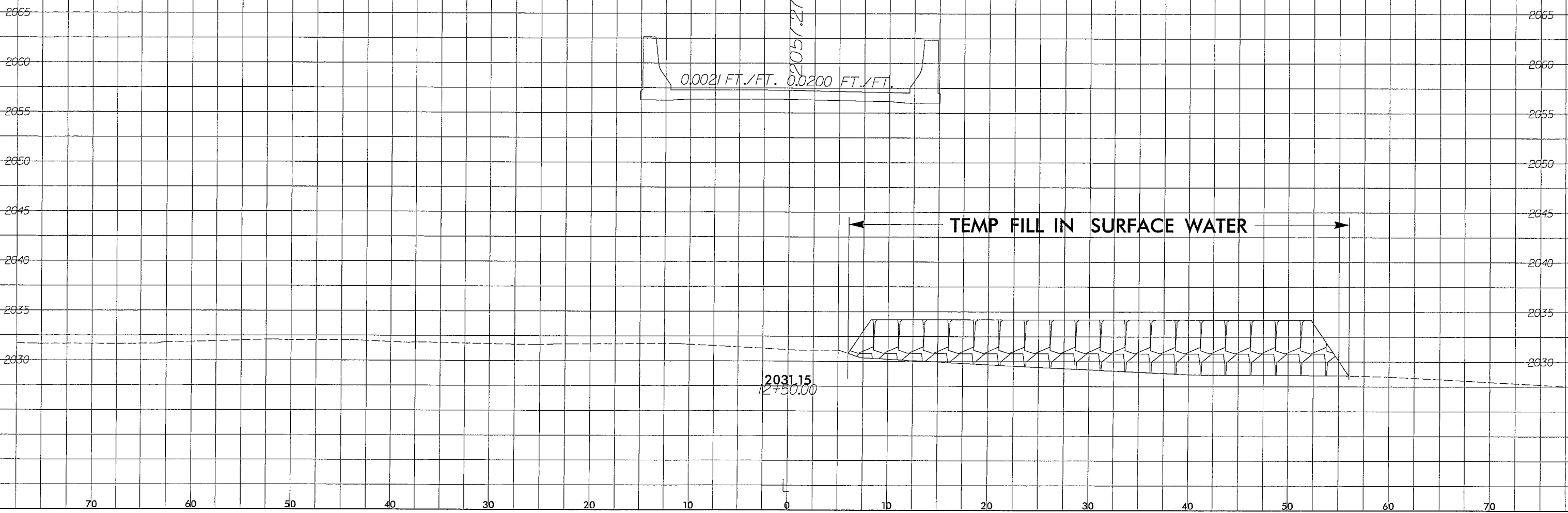

2031.15
12+50.00



8/23/99

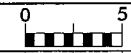

PROJ. REFERENCE NO.
B-2848

SHEET NO.
X-6

70 60 50 40 30 20 10 0 10 20 30 40 50 60 70

2065 2065

2060 2060

2055 2055

2050 2050

2045 2045

2040 2040

2035 2035

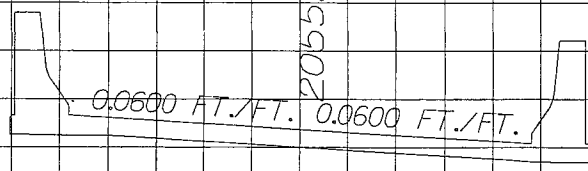

SITE 1

2037.84
13+50.00

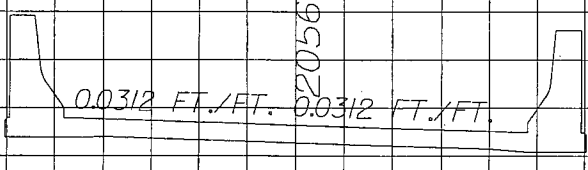

2035.05
13+00.00

2065 2065

2060 2060

2055 2055

2050 2050

2045 2045

2040 2040

2035 2035

70 60 50 40 30 20 10 0 10 20 30 40 50 60 70

\$\$\$\$\$SYTIME\$\$\$\$\$
\$\$\$\$\$DGN\$\$\$\$\$
\$\$\$\$\$USERNAME\$\$\$\$\$

09/08/99
 24-AUG-2006 07:41
 r:\work\2006\proj\2848\2848.tsh
 2848.DWG

CONTRACT: C200905 TIP PROJECT: B-2848

See Sheet 1-A For Index of Sheets

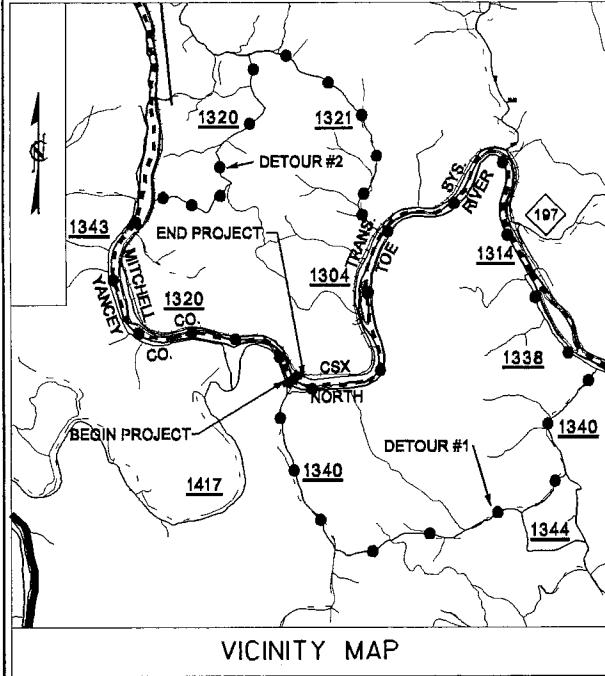

VICINITY MAP

●●●●● DETOUR ROUTE

STATE OF NORTH CAROLINA
 DIVISION OF HIGHWAYS

YANCEY & MITCHELL COUNTIES

**LOCATION: Bridge #143 on SR 1304
 over North Toe River**

TYPE OF WORK: Grading, Paving, Drainage, and Structure

STATE	STATE PROJECT REFERENCE NO.	SHEET NO.	TOTAL SHEETS
N.C.	B-2848	1	
STATE PROJ. NO.	F.A. PROJ. NO.	DESCRIPTION	
32728.1.1	BRZ-1304(4)	PE	
32728.2.2	BRZ-1304(4)	RW & UTIL.	
32728.3.2	BRZ-1304(9)	CONST.	

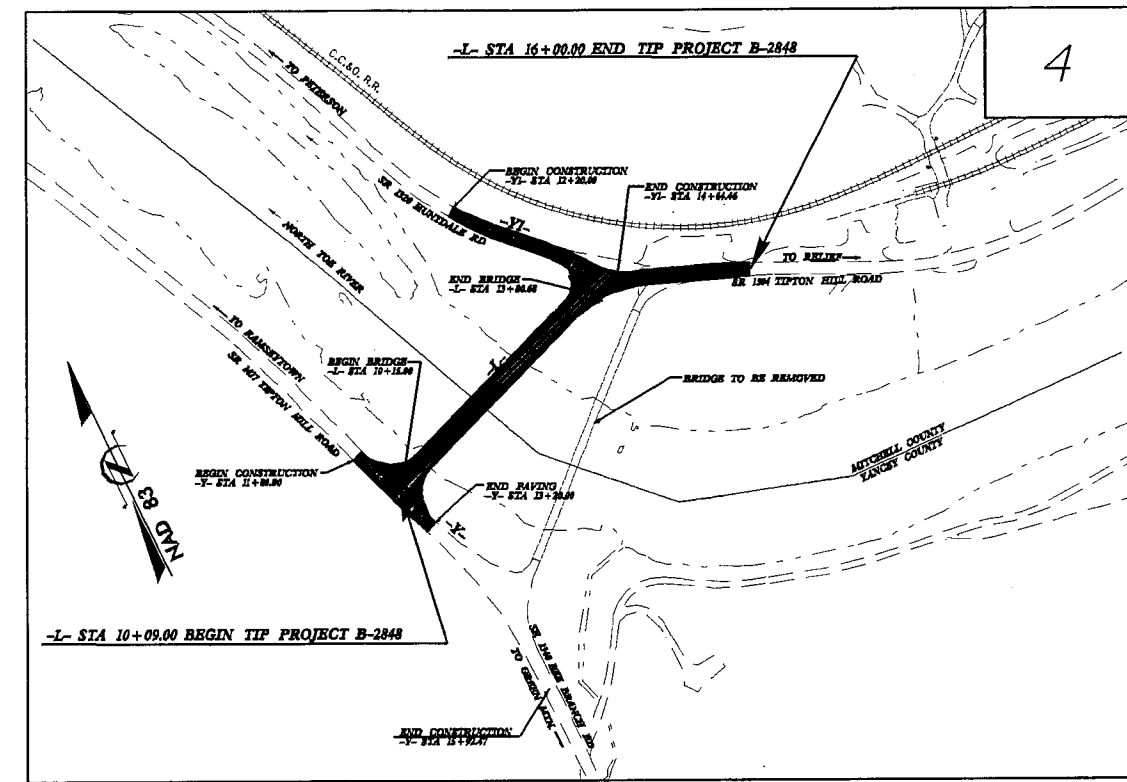

V&M
Vaughn & Melton
 Consulting Engineers

Middlesboro, Kentucky 40288-6520
 Greenville, Tennessee 37639-9978
 Asheville, North Carolina 28813-2796

Copyright © 1994 Vaughn & Melton, Inc. All Rights Reserved.

NCDOT Contact: Teresa Bruton, PE – Project Engineer – Design Services

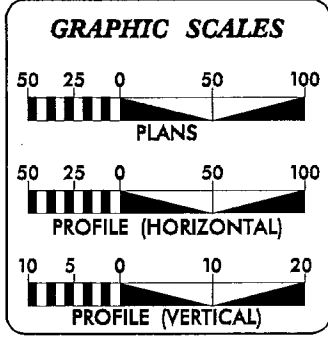

DESIGN DATA

ADT 2001 = 300
 ADT 2025 = 500

DHV = 11 %
 D = 70 %
 T = 5 % *
 V = 35 MPH**

* TTST 2 % DUAL 3 %
 ** DESIGN EXCEPTION REQUIRED FOR HORIZONTAL CURVE

PROJECT LENGTH

LENGTH ROADWAY TIP PROJECT B-2848 = 0.043 MI
 LENGTH STRUCTURE TIP PROJECT B-2848 = 0.069 MI
 TOTAL LENGTH TIP PROJECT B-2848 = 0.112 MI

Prepared For:
DIVISION OF HIGHWAYS
 1000 Birch Ridge Dr., NC, 27610

2002 STANDARD SPECIFICATIONS

RIGHT OF WAY DATE:
 AUGUST 28, 2003

LETTING DATE:

JERRY A. CARTER, PE
 PROJECT ENGINEER

REECE M. SCHULER, PE
 PROJECT DESIGN ENGINEER

HYDRAULICS ENGINEER

SIGNATURE: _____ P.E.

ROADWAY DESIGN ENGINEER

SIGNATURE: _____ P.E.

DATE

DIVISION OF HIGHWAYS
 STATE OF NORTH CAROLINA

STATE DESIGN ENGINEER

DEPARTMENT OF TRANSPORTATION
 FEDERAL HIGHWAY ADMINISTRATION

APPROVED

DIVISION ADMINISTRATOR

DATE

5/28/99

PROJECT REFERENCE NO. B-2848		SHEET NO. 2	
RW SHEET NO.			
ROADWAY DESIGN ENGINEER		HYDRAULICS ENGINEER	

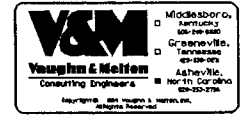

PAVEMENT SCHEDULE	
C1	PROP. APPROX. 1 1/4" ASPHALT CONCRETE SURFACE COURSE, TYPE SF0.5A, AT AN AVERAGE RATE OF 137.5 LBS. PER SQ. YD.
C2	PROP. APPROX. 2 1/2" ASPHALT CONCRETE SURFACE COURSE TYPE SF0.5A, AT AN AVERAGE RATE OF 137.5 LBS. PER SQ. YD. IN EACH OF TWO LAYERS.
E1	PROP. APPROX. 4 1/2" ASPHALT CONCRETE BASE COURSE, TYPE B25.0B, AT AN AVERAGE RATE OF 513 LBS. PER SQ. YD.
T	EARTH MATERIAL.
U	EXISTING PAVEMENT.

NOTE: PAVEMENT EDGE SLOPES ARE 1:1 UNLESS SHOWN OTHERWISE.

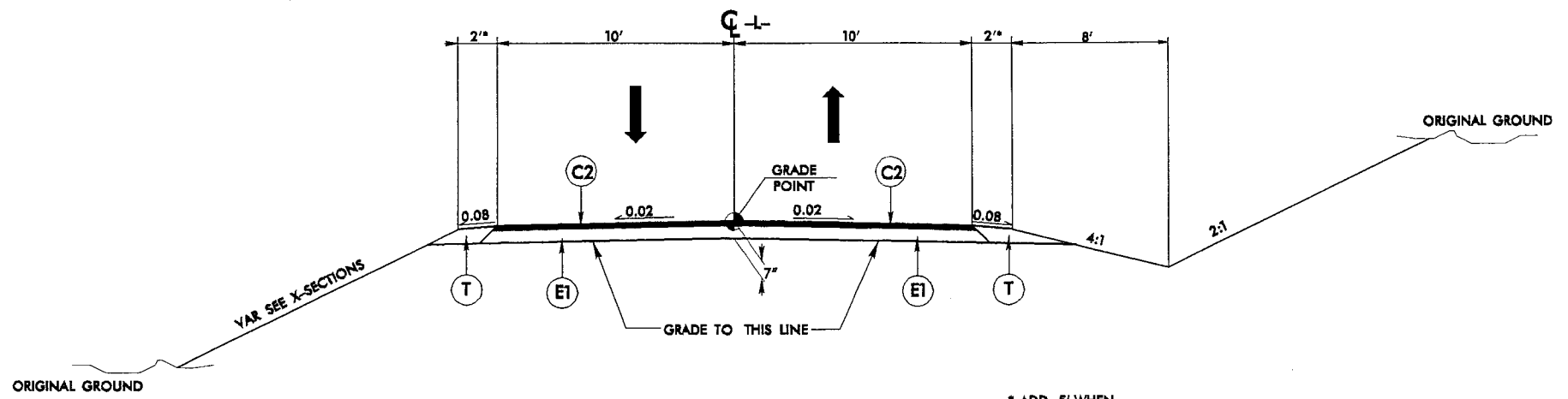

TYPICAL SECTION NO. 1

* ADD 5' WHEN USING GUARDRAIL

USE TYPICAL SECTION NO. 1
 -L- STA. 10+09.00 TO -L- STA. 10+15.00 (BEG. BRIDGE)
 -L- STA. 13+80.68 (END BRIDGE) TO STA. 15+50.00

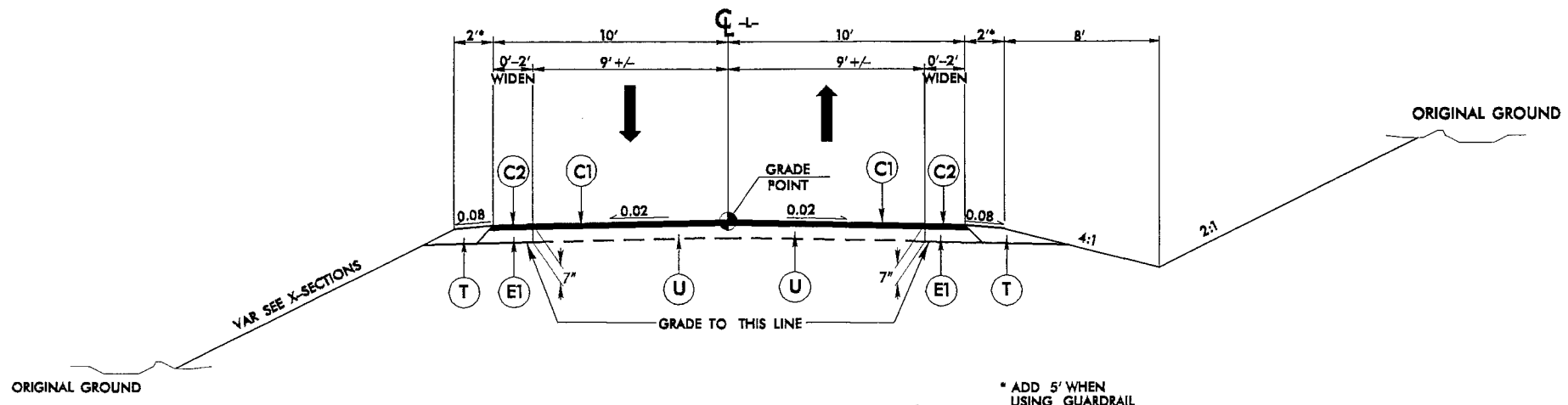

TYPICAL SECTION NO. 2

* ADD 5' WHEN USING GUARDRAIL

USE TYPICAL SECTION NO. 2
 -L- STA. 15+50.00 TO STA. 16+00.00

PAVEMENT SCHEDULE	
C1	PROP. APPROX. 1 1/4" ASPHALT CONCRETE SURFACE COURSE, TYPE SF9.5A, AT AN AVERAGE RATE OF 137.5 LBS. PER SQ. YD.
C2	PROP. APPROX. 2 1/2" ASPHALT CONCRETE SURFACE COURSE TYPE SF9.5A, AT AN AVERAGE RATE OF 137.5 LBS. PER SQ. YD. IN EACH OF TWO LAYERS.
E1	PROP. APPROX. 4 1/2" ASPHALT CONCRETE BASE COURSE, TYPE B25.0B, AT AN AVERAGE RATE OF 513 LBS. PER SQ. YD.
T	EARTH MATERIAL.
U	EXISTING PAVEMENT.

NOTE: PAVEMENT EDGE SLOPES ARE 1:1 UNLESS SHOWN OTHERWISE.

PROJECT REFERENCE NO. B-2848	SHEET NO. 2-A
RW SHEET NO.	
ROADWAY DESIGN ENGINEER	HYDRAULICS ENGINEER

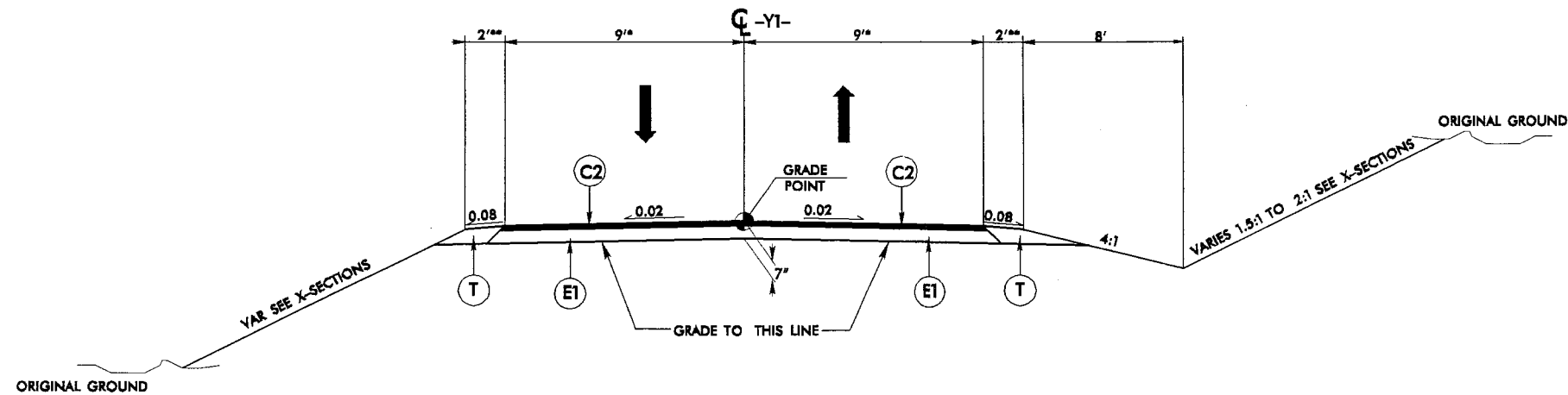

TYPICAL SECTION NO. 3

* VARIES FROM 7.5' TO 9' STA 12+20 TO STA 12+70
 ** ADD 5' WHEN USING GUARDRAIL

USE TYPICAL SECTION NO. 3
 -Y- STA. 12+20.00 TO STA. 14+64.46

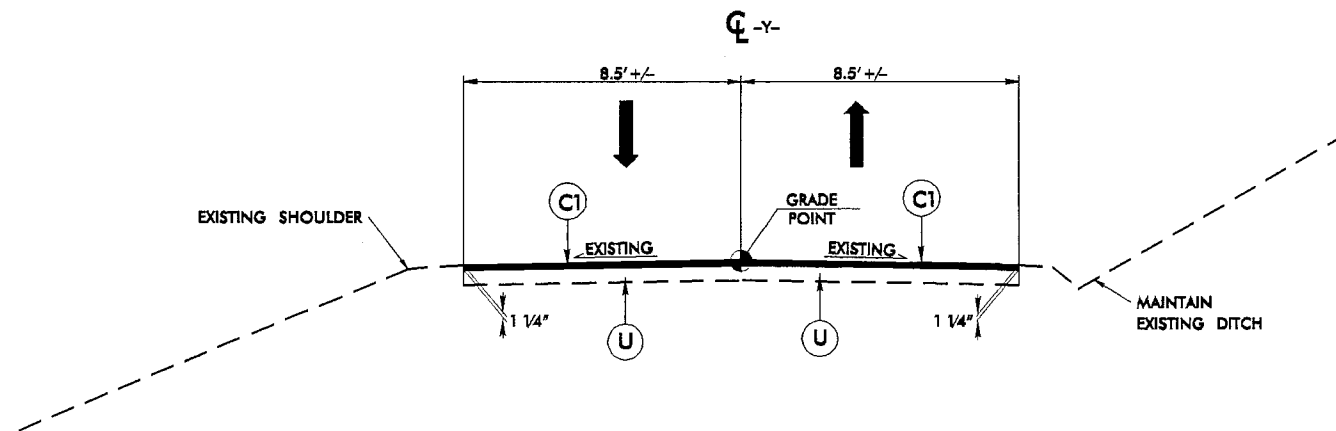

TYPICAL SECTION NO. 4

* ADD 5' WHEN USING GUARDRAIL

USE TYPICAL SECTION NO. 4
 -Y- STA. 11+80.00 TO STA. 13+20.00

DIVISION OF HIGHWAYS
 STATE OF NORTH CAROLINA

SUMMARY OF EARTHWORK

IN CUBIC YARDS

LOCATION	UNCLASSIFIED EXCAVATION	UNDERCUT	EMBT + %	BORROW	WASTE
SUMMARY 1					
-Y- 11+80.00 TO -Y- 13+20.00	0		1	1	
-L- 10+09.00 TO -L- 10+15.00 (BEG. BRIDGE)	0		0	0	
SUBTOTAL SUMMARY 1	0		1	1	
SUMMARY 2					
-L- 13+80.68 (END BRIDGE) TO -L- 16+00.00	320		604	284	
-YI- 12+20.00 TO -YI- 14+64.46	710		824	114	
SUBTOTAL SUMMARY 2	1030		1428	398	
TOTAL					
ESTIMATED SHOULDER CONSTRUCTION			151	151	
PROJECT TOTAL	1030		1580	550	
EST. 5% FOR REPLACING TOP SOIL ON BORROW PITS				28	
GRAND TOTAL	1030			578	
SAY	1050			600	
DDE = 65 CY					

Approximate quantities only. Unclassified excavation, borrow excavation, fine grading, clearing and grubbing, breaking of existing pavement and removal of existing pavement will be paid for at the contract lump sum price for "grading".

8/17/99

DATUM DESCRIPTION

THE LOCALIZED COORDINATE SYSTEM DEVELOPED FOR THIS PROJECT IS BASED ON THE STATE PLANE COORDINATES ESTABLISHED BY MOSS FOR MONUMENT "HUNTDAL".

WITH NAD 1983/95 STATE PLANE GRID COORDINATES OF NORTHING: 844866.890(1) EASTING: 1019080.400(1)

THE AVERAGE COMBINED GRID FACTOR USED ON THIS PROJECT (GROUND TO GRID) IS: 0.99905557

THE N.C. LAMBERT GRID BEARING AND LOCALIZED HORIZONTAL GROUND DISTANCE FROM "HUNTDAL" TO -L- STATION 10+00.00 IS S 85° 39' 48.1" W 1,105.63'

ALL LINEAR DIMENSIONS ARE LOCALIZED HORIZONTAL DISTANCES VERTICAL DATUM USED IS NAVD 88

PROJECT REFERENCE NO. B-2848		SHEET NO. 4	
R/W SHEET NO.			
ROADWAY DESIGN ENGINEER		HYDRAULICS ENGINEER	

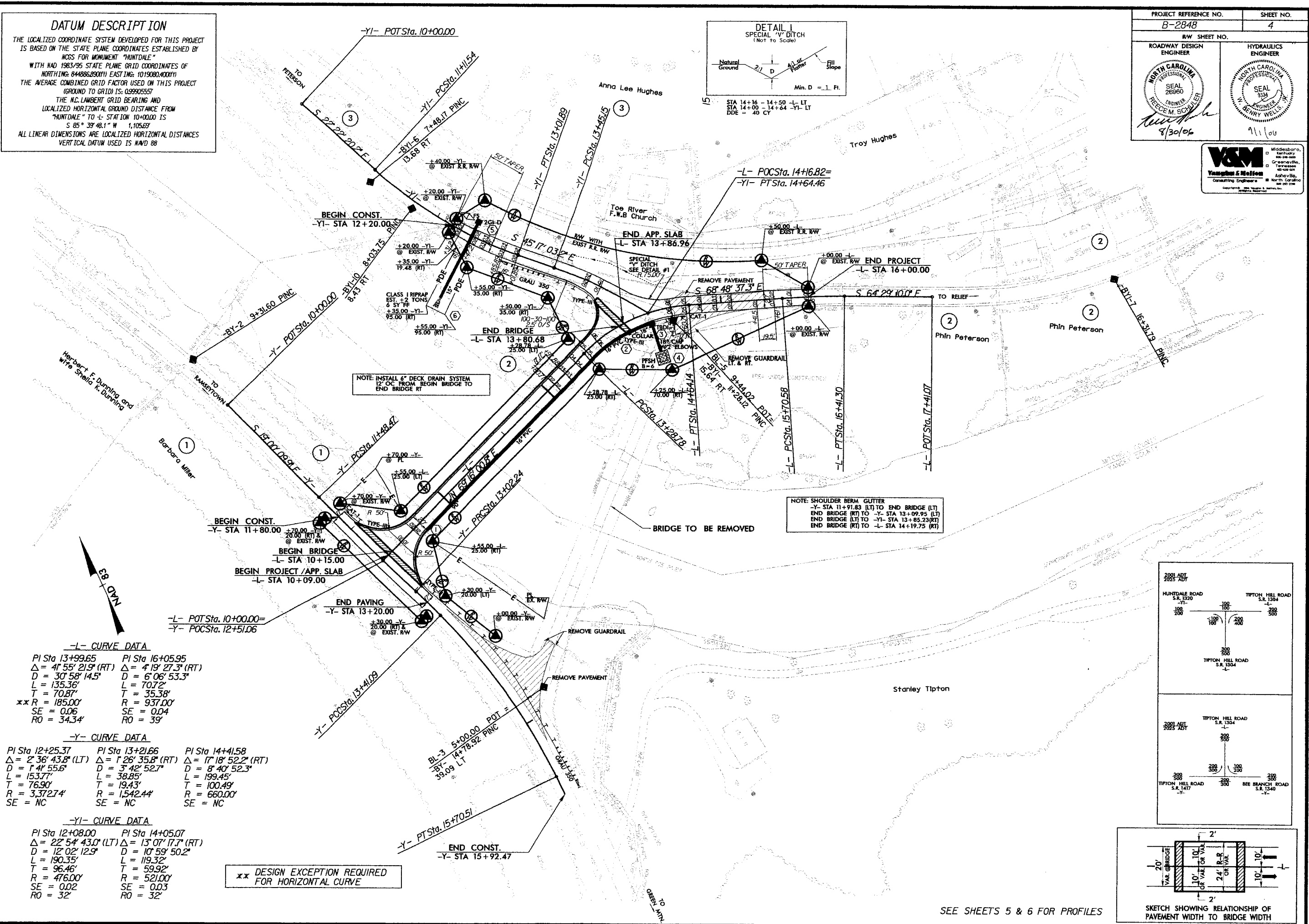
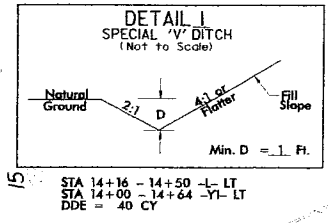

NOTE: INSTALL 6" DECK DRAIN SYSTEM 12" OC FROM BEGIN BRIDGE TO END BRIDGE RT

NOTE: SHOULDER BERM GLUTTER
 -Y- STA 11+91.83 (LT) TO END BRIDGE (LT)
 END BRIDGE (RT) TO -Y- STA 13+09.95 (LT)
 END BRIDGE (LT) TO -Y- STA 13+85.23 (RT)
 END BRIDGE (RT) TO -L- STA 14+19.75 (RT)

-L- CURVE DATA

PI Sta 13+99.65	PI Sta 16+05.95
$\Delta = 4^\circ 55' 21.9"$ (RT)	$\Delta = 4^\circ 19' 27.3"$ (RT)
D = 30' 58" 14.5"	D = 6' 06" 53.3"
L = 135.36'	L = 70.72'
T = 70.87'	T = 35.38'
** R = 185.00'	R = 937.00'
SE = 0.06	SE = 0.04
RO = 34.34'	RO = 39'

-Y- CURVE DATA

PI Sta 12+25.37	PI Sta 13+21.66	PI Sta 14+15.8
$\Delta = 2^\circ 36' 43.8"$ (LT)	$\Delta = 1^\circ 26' 35.8"$ (RT)	$\Delta = 1^\circ 18' 52.2"$ (RT)
D = 1' 44" 55.6"	D = 3' 42" 52.7"	D = 8' 40" 52.3"
L = 153.77'	L = 38.85'	L = 199.45'
T = 76.90'	T = 19.43'	T = 100.49'
R = 3,372.74'	R = 1,542.44'	R = 660.00'
SE = NC	SE = NC	SE = NC

-YI- CURVE DATA

PI Sta 12+08.00	PI Sta 14+05.07
$\Delta = 22^\circ 54' 43.0"$ (LT)	$\Delta = 13^\circ 07' 17.7"$ (RT)
D = 12' 02" 12.9"	D = 10' 59" 50.2"
L = 190.35'	L = 119.32'
T = 96.46'	T = 59.92'
R = 476.00'	R = 521.00'
SE = 0.02	SE = 0.03
RO = 32'	RO = 32'

** DESIGN EXCEPTION REQUIRED FOR HORIZONTAL CURVE

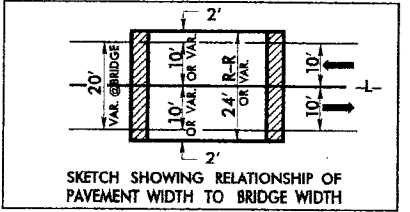
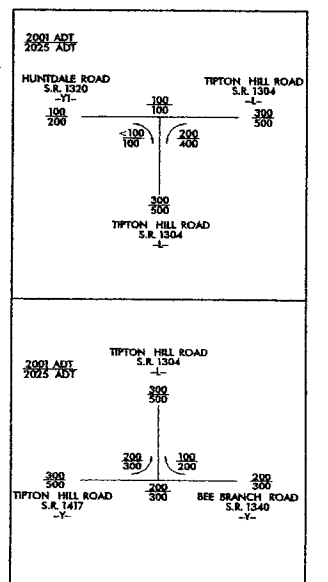

SEE SHEETS 5 & 6 FOR PROFILES

REVISIONS

***** SYSTEM TIME *****

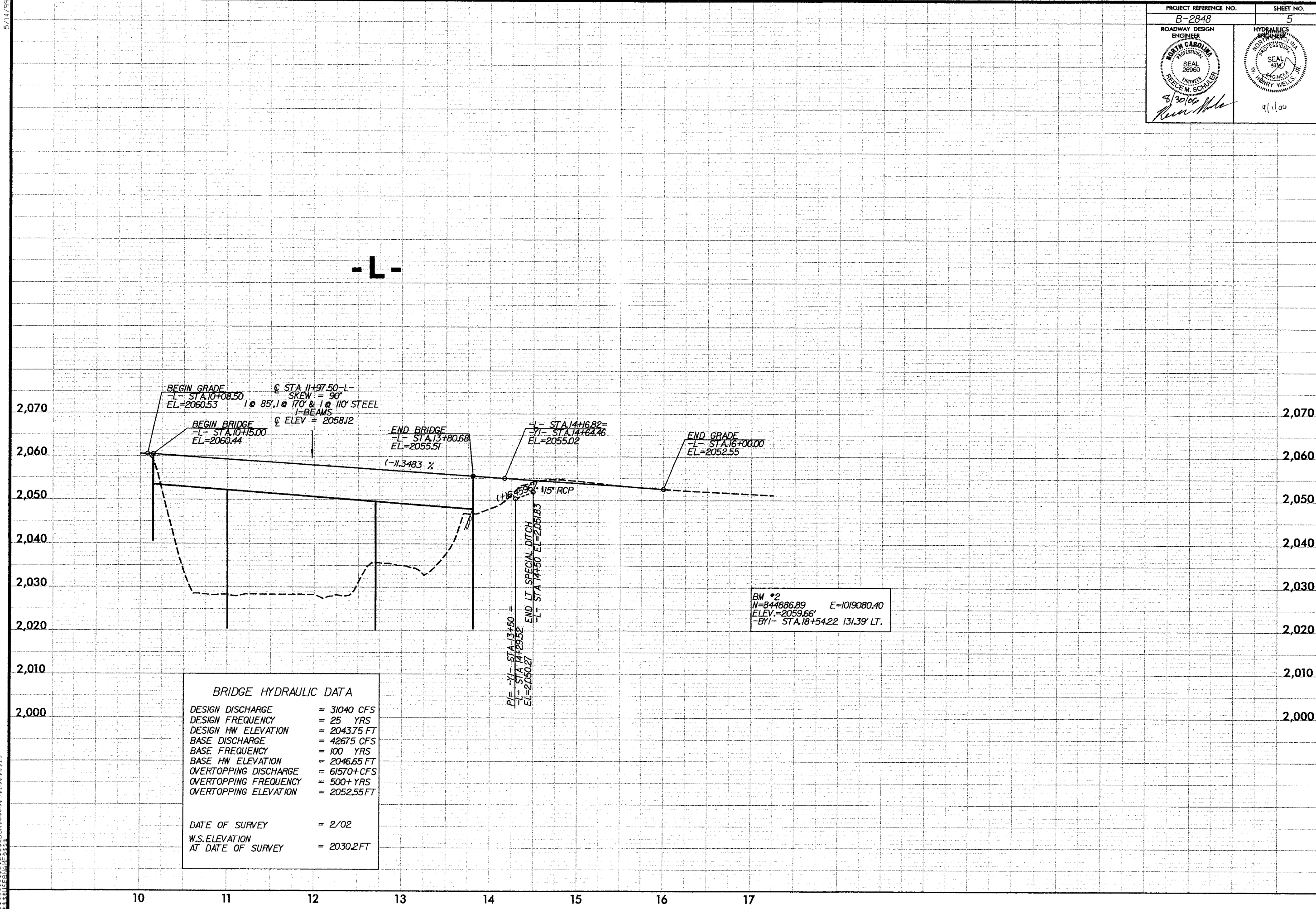

BRIDGE HYDRAULIC DATA	
DESIGN DISCHARGE	= 31040 CFS
DESIGN FREQUENCY	= 25 YRS
DESIGN HW ELEVATION	= 2043.75 FT
BASE DISCHARGE	= 42675 CFS
BASE FREQUENCY	= 100 YRS
BASE HW ELEVATION	= 2046.65 FT
OVERTOPPING DISCHARGE	= 61570+ CFS
OVERTOPPING FREQUENCY	= 500+ YRS
OVERTOPPING ELEVATION	= 2052.55 FT
DATE OF SURVEY	= 2/02
W.S.ELEVATION AT DATE OF SURVEY	= 2030.2 FT

5/14/99
 SYSTEMS
 11/11/06

5/28/99

PROJECT REFERENCE NO. B-2848	SHEET NO. 6
ROADWAY DESIGN ENGINEER	HYDRAULICS ENGINEER

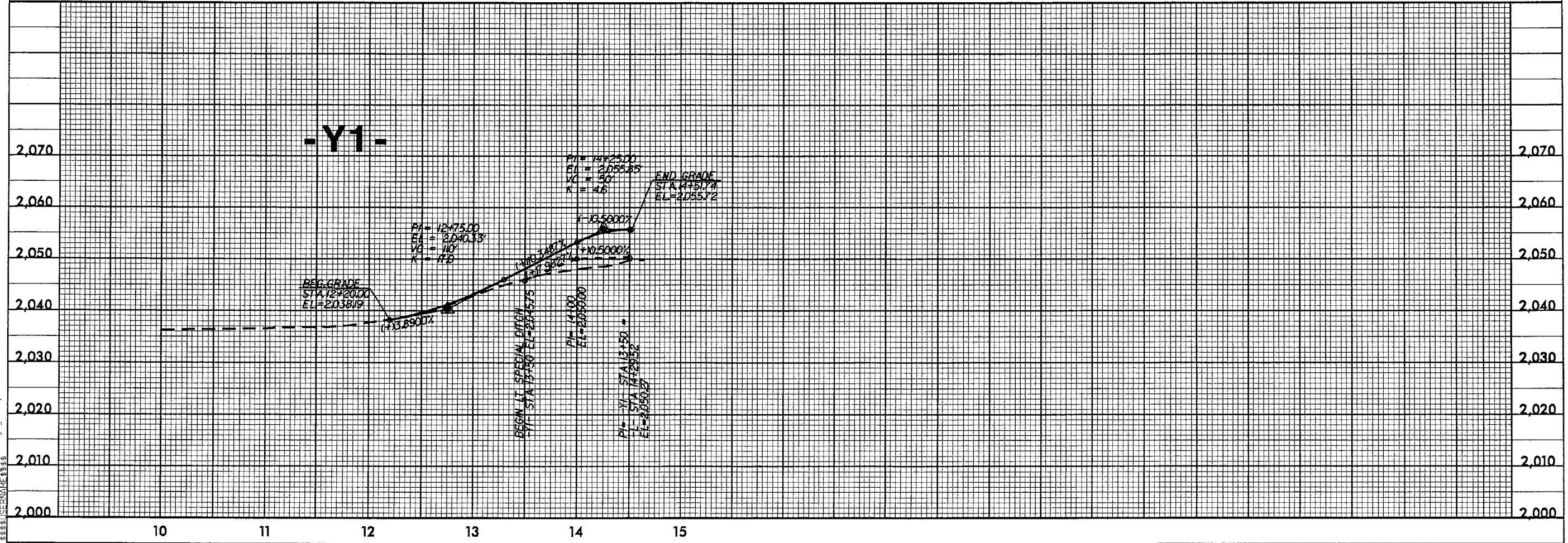
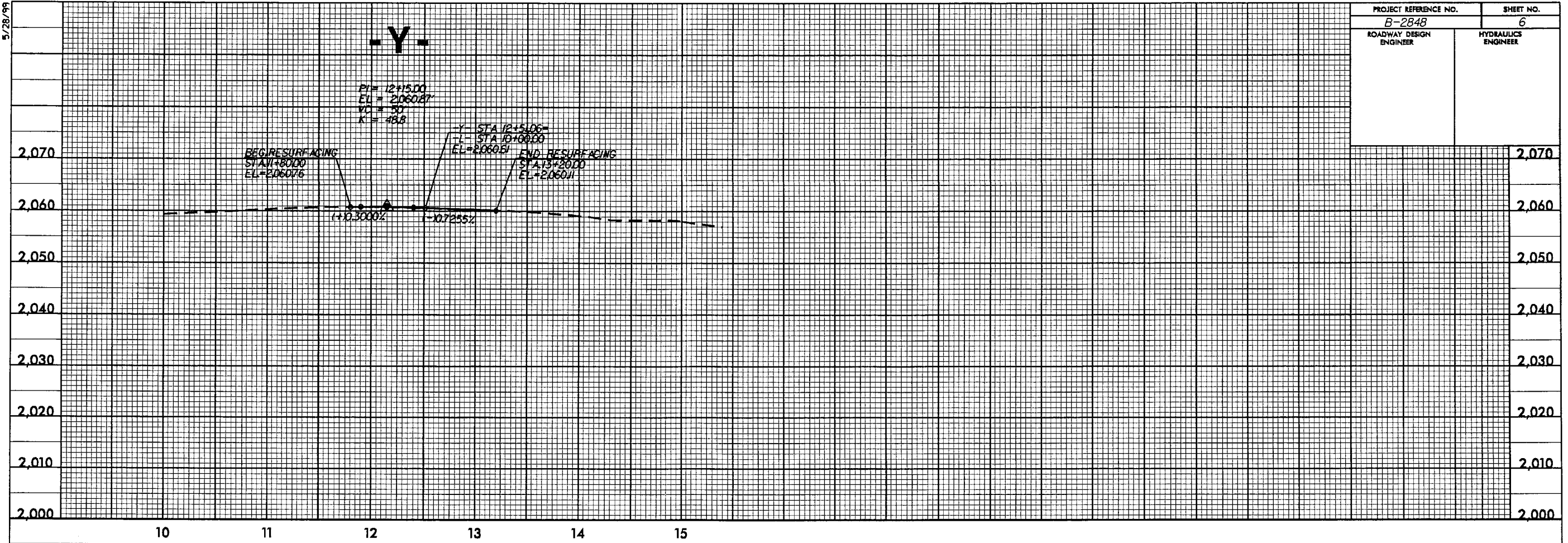

20-AUG-2006 07:44
F:\PROJECTS\2848\y1_06.pfl
SSSUSSE@MIE