

PROJECT COMMITMENTS

TIP Project No. U-2579C
Winston-Salem Northern Beltway
(Eastern Section) from US 311 to US 158
Forsyth County
Federal-Aid Project No. NHF-0918 (93)
WBS No. 34839.2.10

COMMITMENTS FROM PROJECT DEVELOPMENT AND DESIGN

All commitments developed during the project development and design phase have been incorporated into the design. Current status, changes, or additions to the project commitments as shown in the environmental document for the project are printed in *italic* font.

PDEA, Roadway Design, Division 9

1. A design noise study will be prepared for the selected alternative. The date of public knowledge for noise abatement purposes is the date the Record of Decision (ROD) is signed. Projects let for construction on or after July 13, 2011 shall be reviewed under NCDOT 2011 noise analysis criteria; however, the original date of public knowledge shall remain unchanged.

Action: The ROD was signed in February 2008. Design Noise Reports based upon preliminary design were completed for U-2579 AB, B & C in 2009. A Revised Design Noise Report based upon final design will be completed for U-2579C in 2015. Revised Design Noise Reports based upon final design of U-2579AA and AB will be completed prior to Project Letting scheduled for October 2021. All Design Noise Reports are subject to approval by NCDOT and FHWA. The original Date of Public Knowledge of February 15, 2008 will remain unchanged for all sections of U-2579. A revised DNR will be prepared in 2015 for U-2579C under the NCDOT 2011 noise abatement criteria.

Update 3/28/2017: A DNR for U-2579C was completed in July 2016 under the 2011 NCDOT Traffic Noise Abatement Policy. An Addendum to the DNR will be prepared in 2017 to reflect additional changes that have occurred during the final design process.

Roadway Design, Utility Unit, Division 9, Right of Way Branch, GeoEnvironmental

1. NCDOT will continue to work with residents of affected communities to develop mitigation strategies for community impacts. The following options will be considered during final design to minimize impacts to communities/subdivisions: construction of noise abatement barriers landscaping or vegetative screens based on NCDOT policies and guidelines. These types of options already have been incorporated into the preliminary engineering designs where practicable, but will be further considered during final design.

Action: The final designs are completed; the above commitments have been addressed.

2. During final design, all utility providers and railroad operators would be coordinated with to ensure that the proposed design and construction of the project would not substantially disrupt service.

This is a standard commitment.

3. The development of this project will be further coordinated with the City of Winston Salem and Forsyth County Parks and Recreation Departments to minimize any conflicts with future parks and greenways planning. Provisions will be considered to maintain the future viability of any impacted proposed greenways.

Action: Roadway Design coordinated with the city of Winston Salem and avoided any impacts to greenways.

4. NCDOT will consider wildlife crossings where appropriate in the vicinity of stream crossings, which will allow animals to cross under the Beltway.

Action: No special wildlife crossings are proposed. Opportunities for wildlife to cross exist along streams under bridges and through culverts. Also, small wildlife can use floodplain drains which are provided.

Hydraulics Unit

1. All bridges and culverts located in designated FEMA flood zones will be designed such that an increase in flood elevation would not exceed the lesser of 0.5 foot for the 100-year flood event or the elevation needed to protect structures.

Action: This commitment has been fulfilled.

2. The Hydraulics Unit will coordinate with the NC Floodplain Mapping Program (FMP), to determine status of project with regard to applicability of NCDOT'S Memorandum of Agreement, or approval of a Conditional Letter of Map Revision (CLOMR) and subsequent final Letter of Map Revision (LOMR).

The Hydraulics Unit will continue coordination with the NC Floodplain Mapping Program (FMP) until project completion.

3. NCDOT will avoid installing bridge bents in creeks to the maximum extent practicable.

Action: This commitment has been fulfilled; no bridge bents are located in creeks.

Roadside Environmental, Division 9

1. During design and construction, efforts will be made to minimize the impact to existing vegetative buffers and natural areas. NCDOT will prepare a post construction landscape design/corridor plan to mitigate construction impacts and integrate enhancements, while remaining sensitive to the environment and to the safety of the traveling public.

This is standard commitment; post construction plans will be prepared.

2. NCDOT will incorporate sediment and erosion control measures according to the Design Standards in Sensitive Watersheds for all construction in high quality water (HQW) zones in compliance with 15a NCAC 04B.0124.

Action: There are no qualifying factors present at this section.

Roadway, Hydraulics

1. Generally, 2:1 slopes will be used where possible to minimize culvert length, and NCDOT will shorten culvert lengths where possible and daylight systems between culverts where possible in interchange areas.

Action: The current plans show side slopes near streams and wetlands are mostly 2:1 to minimize impact.

Division 9, Construction Unit

1. A pre-construction survey will be done in areas of possible concern regarding structural damage to assess a pre-construction condition.

This commitment will be done prior to initiation of construction.

Division 9

1. NCDOT will coordinate with local media during the construction of the project to alert the public of traffic restrictions and construction related activities.

This commitment will be implemented during construction

2. This project involves construction activities on or adjacent to FEMA-regulated stream(s). Therefore, the Division shall submit sealed as-built construction plans to the Hydraulics Unit upon completion of project construction, certifying that the drainage structure(s) and roadway embankment that are located within the 100-year floodplain were built as shown in the construction plans, both horizontally and vertically.

This commitment will be fulfilled after the completion of the project.

PDEA-Environmental Analysis Unit

1. The biological conclusion for the Northern long-eared bat is Unresolved. Construction authorization will not be requested until ESA compliance is satisfied for the northern long-eared bat.

Action: NCDOT has determined that the proposed action does not require separate consultation on the grounds that the proposed action is consistent with the final Section 7 4(d) rule, codified at 50 C.F.R. 17.40(o) and effective February 16, 2016. Section 7 responsibilities are therefore considered fulfilled for NLEB. Notification was made to USFWS on March 30, 2017.

COMMITMENTS FROM PERMITTING

Division 9, Construction Unit

1. UNKNOWN CULTURAL RESOURCES: While accomplishing the authorized work, if the permittee discovers any previously unknown cultural resources, the District Engineer will be immediately notified so that required coordination can be initiated with the North Carolina Division of Cultural Resources.
2. INSTALLATION OF CULVERTS: Unless otherwise requested in the applicant's application and depicted on the approved work plans, culverts greater than 48 inches in diameter will be buried at least one foot below the bed of the stream. Culverts 48 inches in diameter and less shall be buried or placed on the stream bed as practicable and appropriate to maintain aquatic passage, and every effort shall be made to maintain existing channel slope. The bottom of the culvert must be placed at a depth below the natural stream bottom to provide for passage during drought or low flow conditions. Destabilizing the channel and head cutting upstream should be considered in the placement of the culvert. The following pipes are exempt from this condition:
 - Site 6: 24-inch Reinforced Concrete Pipe (RCP) outlet at station 31+30-Y1-Rt
 - Site 7: 72-inch RCP inlet at station 413+74-L-Lt
 - Site 9: 78-inch CSP inlet at station 21+46-Y1RPD-Rt; 78-inch CSP at station 25+82-Y1RDP-Lt
 - Site 14: 42-inch RCP outlet at station 42+14-Y1-Rt



DEPARTMENT OF THE ARMY
WILMINGTON DISTRICT, CORPS OF ENGINEERS
69 DARLINGTON AVENUE
WILMINGTON, NORTH CAROLINA 28403-1343

August 17, 2017

Regulatory Division

Action ID: SAW-2017-01232

Mr. Philip S. Harris III, P.E., C.P.M.
Natural Environment Section Head
North Carolina Department of Transportation
Division of Highways
1598 Mail Service Center
Raleigh, North Carolina 27699-1598

Dear Mr. Harris:

In accordance with the written request of August 17, 2017, and the ensuing administrative record, enclosed is a Department of the Army (DA) Permit to authorize the construct of a 1.99 mile long portion of new location roadway known as the Winston-Salem Northern Beltway between US 158 and US-311 in Forsyth County, TIP U-2579C. The project involves the permanent discharge of dredged or fill material into 977 linear feet of stream channel (921 linear feet of permanent loss and 76 linear feet of bank stabilization), 0.88 acre of riparian wetlands (0.79 acre of permanent fill, and 0.09 acre of mechanized clearing), as well as the temporary discharge of dredged or fill material into 199 linear feet of stream channel.

Any deviation in the authorized work will likely require modification of this permit. If a change in the authorized work is necessary, you should promptly submit revised plans to the Corps showing the proposed changes. You may not undertake the proposed changes until the Corps notified you that your permit has been modified.

Carefully read your permit. The general and special conditions are important. Your failure to comply with these conditions could result in a violation of Federal law. Certain significant general conditions require that:

- a. You must complete construction before **December 31, 2022**.
- b. You must notify this office in advance as to when you intend to commence and complete work.
- c. You must allow representatives from this office to make periodic visits to your worksite as deemed necessary to assure compliance with permit plans and conditions.

You should address all questions regarding this authorization to Mr. James Lastinger in the Raleigh Regulatory Field Office, telephone number (919) 554-4884, extension 32.

Thank you in advance for completing our Customer Survey Form. This can be accomplished by visiting our web-site at http://corpsmapu.usace.army.mil/cm_apex/f?p=136:4:0 and completing the survey on-line. We value your comments and appreciate your taking the time to complete a survey each time you interact with our office.

Sincerely,

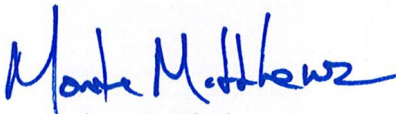
for/ Robert J. Clark
Colonel, U.S. Army
District Commander

Enclosures

Copy Furnished: (with enclosures):

Chief, Source Data Unit
NOAA/National Ocean Service
Attn: Sharon Tear N/CS261
1315 East-West Hwy., Rm 7316
Silver Spring, Maryland 20910-3282

Copies Furnished: (with special conditions and plans):

Mr. Pete Benjamin
U.S. Fish and Wildlife Service
Raleigh Ecological Service Field Office
Post Office Box 33726
Raleigh, North Carolina 27636-3726

Mr. Kenneth Riley, Ph.D.
Habitat Conservation Division
National Marine Fisheries Service Southeast Region
101 Pivers Island Road
Beaufort, North Carolina 28516

Mr. Todd Bowers
Oceans, Wetlands and Streams Protection Branch
Wetlands and Streams Regulatory Section
U.S. Environmental Protection Agency – Region 4
Sam Nunn Atlanta Federal Center
61 Forsyth Street, SW
Atlanta, Georgia 30303-8931

Mr. Doug Huggett
Division Coastal Management
N.C. Department of Environment
And Natural Resources
400Commerce Avenue
Morehead City, North Carolina 28557

Dr. Pace Wilber
Habitat Conservation Division – Atlantic Branch
NOAA Fisheries Service
219 Fort Johnston Road
Charleston, South Carolina 29412

DEPARTMENT OF THE ARMY PERMIT

Permittee **NORTH CAROLINA DEPARTMENT OF TRANSPORTATION**
ATTN: MR. PHILIP S. HARRIS III, P.E., C.P.M.

Permit No. **SAW-2017-01232**

Issuing Office **CESAW-RG-R**

NOTE: The term "you" and its derivatives, as used in this permit, means the permittee or any future transferee. The term "this office" refers to the appropriate district or division office of the Corps of Engineers having jurisdiction over the permitted activity or the appropriate official of that office acting under the authority of the commanding officer.

You are authorized to perform work in accordance with the terms and conditions specified below.

Project Description: The project involves construction of 1.99 mile long portion of new location roadway known as the Winston-Salem Northern Beltway between US 158 and US-311 in Forsyth County, TIP U-2579C. The project involves the permanent discharge of dredged or fill material into 977 linear feet of stream channel (921 linear feet of permanent loss and 76 linear feet of bank stabilization), 0.88 acre of riparian wetlands (0.79 acre of permanent fill, and 0.09 acre of mechanized clearing), as well as the temporary discharge of dredged or fill material into 199 linear feet of stream channel.

Project Location: The project area is a new alignment linear transportation corridor from US 158 running northwest to a new interchange with US-311 located east of Winston-Salem, Forsyth County, North Carolina. (36.15003°N, -80.1695°W [central point]).

Permit Conditions:

General Conditions:

1. The time limit for completing the work authorized ends on **December 31, 2022.** If you find that you need more time to complete the authorized activity, submit your request for a time extension to this office for consideration at least one month before the above date is reached.
2. You must maintain the activity authorized by this permit in good condition and in conformance with the terms and conditions of this permit. You are not relieved of this requirement if you abandon the permitted activity, although you may make a good faith transfer to a third party in compliance with General Condition 4 below. Should you wish to cease to maintain the authorized activity or should you desire to abandon it without a good faith transfer, you must obtain a modification of this permit from this office, which may require restoration of the area.
3. If you discover any previously unknown historic or archeological remains while accomplishing the activity authorized by this permit, you must immediately notify this office of what you have found. We will initiate the Federal and state coordination required to determine if the remains warrant a recovery effort or if the site is eligible for listing in the National Register of Historic Places.
4. If you sell the property associated with this permit, you must obtain the signature of the new owner in the space provided and forward a copy of the permit to this office to validate the transfer of this authorization.
5. If a conditioned water quality certification has been issued for your project, you must comply with the conditions specified in the certification as special conditions to this permit. For your convenience, a copy of the certification is attached if it contains such conditions.

6. You must allow representatives from this office to inspect the authorized activity at any time deemed necessary to ensure that it is being or has been accomplished in accordance with the terms and conditions of your permit,

Special Conditions:

SEE ATTACHED SPECIAL CONDITIONS

Further Information:

1. Congressional Authorities: You have been authorized to undertake the activity described above pursuant to:
 - () Section 10 of the Rivers and Harbors Act of 1899 (33 U.S.C. 403).
 - (X) Section 404 of the Clean Water Act (33 U.S.C. 1344).
 - () Section 103 of the Marine Protection, Research and Sanctuaries Act of 1972 (33 U.S.C. 1413).
2. Limits of this authorization.
 - a. This permit does not obviate the need to obtain other Federal, state, or local authorizations required by law.
 - b. This permit does not grant any property rights or exclusive privileges.
 - c. This permit does not authorize any injury to the property or rights of others.
 - d. This permit does not authorize interference with any existing or proposed Federal project.
3. Limits of Federal Liability. In issuing this permit, the Federal Government does not assume any liability for the following:
 - a. Damages to the permitted project or uses thereof as a result of other permitted or unpermitted activities or from natural causes.
 - b. Damages to the permitted project or uses thereof as a result of current or future activities undertaken by or on behalf of the United States in the public interest.
 - c. Damages to persons, property, or to other permitted or unpermitted activities or structures caused by the activity authorized by this permit.
 - d. Design or construction deficiencies associated with the permitted work.
 - e. Damage claims associated with any future modification, suspension, or revocation of this permit.
4. Reliance on Applicant's Data: The determination of this office that issuance of this permit is not contrary to the public interest was made in reliance on the information you provided.
5. Reevaluation of Permit Decision. This office may reevaluate its decision on this permit at any time the circumstances warrant. Circumstances that could require a reevaluation include, but are not limited to, the following:
 - a. You fail to comply with the terms and conditions of this permit.
 - b. The information provided by you in support of your permit application proves to have been false, incomplete, or inaccurate (See 4 above).

c. Significant new information surfaces which this office did not consider in reaching the original public interest decision.

Such a reevaluation may result in a determination that it is appropriate to use the suspension, modification, and revocation procedures contained in 33 CFR 325.7 or enforcement procedures such as those contained in 33 CFR 326.4 and 326.5. The referenced enforcement procedures provide for the issuance of an administrative order requiring you to comply with the terms and conditions of your permit and for the initiation of legal action where appropriate. You will be required to pay for any corrective measures ordered by this office, and if you fail to comply with such directive, this office may in certain situations (such as those specified in 33 CFR 209.170) accomplish the corrective measures by contract or otherwise and bill you for the cost.

6. Extensions. General condition 1 establishes a time limit for the completion of the activity authorized by this permit, Unless there are circumstances requiring either a prompt completion of the authorized activity or a reevaluation of the public interest decision, the Corps will normally give favorable consideration to a request for an extension of this time limit.

Your signature below, as permittee, indicates that you accept and agree to comply with the terms and conditions of this permit.



(PERMITTEE) NORTH CAROLINA DEPARTMENT OF TRANSPORTATION
for ATTN: MR. PHILIP S. HARRIS III, P.E., C.P.M. 08-17-2017

(DATE)

This permit becomes effective when the Federal official, designated to act for the Secretary of the Army, has signed below.

for 

(DISTRICT COMMANDER) ROBERT J. CLARK, COLONEL 17 Aug 2017

(DATE)

When the structures or work authorized by this permit are still in existence at the time the property is transferred, the terms and conditions of this permit will continue to be binding on the new owner(s) of the property. To validate the transfer of this permit and the associated liabilities associated with compliance with its terms and conditions, have the transferee sign and date below.

(TRANSFeree) _____
(DATE)

SPECIAL CONDITIONS
ACTION ID: SAW-2017-01232
NORTH CAROLINA DEPARTMENT OF TRANSPORTATION
I-74 WINSTON-SALEM NORTHERN BELTWAY TIP NO. U-2579C

WORK LIMITS

1. **CONSTRUCTION PLANS:** All work authorized by this permit must be performed in strict compliance with the attached plans for U-2579C, Wetland Surface Water Impacts Permit, dated June 13, 2017, Any modification to these plans must be approved by the US Army Corps of Engineers (USACE) prior to implementation.
2. **UNAUTHORIZED DREDGE OR FILL:** Except as authorized by this permit or any USACE approved modification to this permit, no excavation, fill or mechanized land-clearing activities shall take place at any time in the construction or maintenance of this project, within waters or wetlands. This permit does not authorize temporary placement or double handling of excavated or fill material within waters or wetlands outside the permitted area. This prohibition applies to all borrow and fill activities connected with this project.
3. **MAINTAIN CIRCULATION AND FLOW OF WATERS:** Except as specified in the plans attached to this permit, no excavation, fill or mechanized land-clearing activities shall take place at any time in the construction or maintenance of this project, in such a manner as to impair normal flows and circulation patterns within waters or wetlands or to reduce the reach of waters or wetlands.
4. **DEVIATION FROM PERMITTED PLANS:** The permittee shall ensure that the construction design plans for this project do not deviate from the permit plans attached to this authorization. Written verification shall be provided that the final construction drawings comply with the attached permit drawings prior to any active construction in waters of the United States, including wetlands. Any deviation in the construction design plans will be brought to the attention of the Corps of Engineers, Mr. James Lastinger of the Raleigh Regulatory Field Office prior to any active construction in waters or wetlands.
5. **PRECONSTRUCTION MEETING:** The Permittee shall schedule an onsite preconstruction meeting between its representatives, the contractor's representatives and the appropriate Corps of Engineers Project Manager prior to undertaking any work within jurisdictional waters and wetlands to ensure that there is a mutual understanding of all terms and conditions contained within the Department of the Army permit. The Permittee shall notify the Corps of Engineers Project Manager a minimum of thirty (30) days in advance of the scheduled meeting in order to provide that individual with ample opportunity to schedule and participate in the required meeting.
6. **BORROW AND WASTE:** To ensure that all borrow and waste activities occur on high ground and do not result in the degradation of adjacent wetlands and streams, except as authorized by this permit, the permittee shall require its contractors and/or agents to identify all areas to be used to borrow material, or to dispose of dredged, fill, or waste material. The permittee shall provide the USACE with appropriate maps indicating the

SPECIAL CONDITIONS
ACTION ID: SAW-2017-01232
NORTH CAROLINA DEPARTMENT OF TRANSPORTATION
I-74 WINSTON-SALEM NORTHERN BELTWAY TIP NO. U-2579C

locations of proposed borrow or waste sites as soon as the permittee has that information. The permittee will coordinate with the USACE before approving any borrow or waste sites that are within 400 feet of any streams or wetlands.

RELATED LAWS

7. **WATER CONTAMINATION:** All mechanized equipment will be regularly inspected and maintained to prevent contamination of waters and wetlands from fuels, lubricants, hydraulic fluids, or other toxic materials. In the event of a spill of petroleum products or any other hazardous waste, the permittee shall immediately report it to the N.C. Division of Water Quality at (919) 733-3300 or (800) 858-0368 and provisions of the North Carolina Oil Pollution and Hazardous Substances Control Act will be followed.

8. The North Carolina Division of Environmental Quality (DEQ) permit/certification number 4123 was issued for this project on July 26, 2017. Special conditions were issued associated with this water quality permit/certification and a copy of these conditions is attached as Exhibit A. These referenced conditions are hereby incorporated as special conditions of this permit.

PROJECT MAINTENANCE

9. **NOTIFICATION OF CONSTRUCTION COMMENCEMENT AND COMPLETION:** The permittee shall advise the Corps in writing prior to beginning the work authorized by this permit and again upon completion of the work authorized by this permit.

10. **PERMIT DISTRIBUTION:** The permittee shall require its contractors and/or agents to comply with the terms and conditions of this permit in the construction and maintenance of this project, and shall provide each of its contractors and/or agents associated with the construction or maintenance of this project with a copy of this permit. A copy of this permit, including all conditions, shall be available at the project site during construction and maintenance of this project.

11. **PERMIT REVOCATION:** The permittee, upon receipt of a notice of revocation of this permit or upon its expiration before completion of the work will, without expense to the United States and in such time and manner as the Secretary of the Army or his authorized representative may direct, restore the water or wetland to its pre-project condition.

12. **CLEAN FILL:** Unless otherwise authorized by this permit, all fill material placed in waters or wetlands shall be generated from an upland source and will be clean and free of any pollutants except in trace quantities. Metal products, organic materials (including debris from land clearing activities), or unsightly debris will not be used. Soils used for fill shall not be contaminated with any toxic substance in concentrations governed by Section 307 of the Clean Water Act.

SPECIAL CONDITIONS
ACTION ID: SAW-2017-01232
NORTH CAROLINA DEPARTMENT OF TRANSPORTATION
I-74 WINSTON-SALEM NORTHERN BELTWAY TIP NO. U-2579C

13. SILT-FENCING: The permittee shall employ all sedimentation and erosion control measures necessary to prevent an increase in sedimentation or turbidity within waters and wetlands outside the permit area. This shall include, but is not limited to, the immediate installation of silt fencing or similar appropriate devices around all areas subject to soil disturbance or the movement of earthen fill, and the immediate stabilization of all disturbed areas. Additionally, the project must remain in full compliance with all aspects of the Sedimentation Pollution Control Act of 1973 (North Carolina General Statutes Chapter 113A Article 4). Fescue will not be planted within wetland areas.

14. EROSION CONTROL MEASURES IN JURISDICTIONAL WATERS:

A. During the clearing phase of the project, heavy equipment must not be operated in surface waters or stream channels. Temporary stream crossings will be used to access the opposite sides of stream channels. All temporary diversion channels and stream crossings will be constructed of non-erodible materials. Grubbing of riparian vegetation will not occur until immediately before construction begins on a given segment of stream channel.

B. No fill or excavation impacts for the purposes of sedimentation and erosion control shall occur within jurisdictional waters, including wetlands, unless the impacts are included on the plan drawings and specifically authorized by this permit.

C. The permittee shall remove all sediment and erosion control measures placed in wetlands or waters, and shall restore natural grades in those areas, prior to project completion.

15. PROHIBITION ON CONCRETE: The permittee shall take measures to prevent live or fresh concrete, including bags of uncured concrete, from coming into contact with any water in or entering into waters of the United States. Water inside coffer dams or casings that has been in contact with concrete shall only be returned to waters of the United States when it no longer poses a threat to aquatic organisms (i.e. concrete is set and cured).

16. INSTALLATION OF CULVERTS: Unless otherwise requested in the applicant's application and depicted on the approved work plans, culverts greater than 48 inches in diameter will be buried at least one foot below the bed of the stream. Culverts 48 inches in diameter and less shall be buried or placed on the stream bed as practicable and appropriate to maintain aquatic passage, and every effort shall be made to maintain existing channel slope. The bottom of the culvert must be placed at a depth below the natural stream bottom to provide for passage during drought or low flow conditions. Destabilizing the channel

SPECIAL CONDITIONS
ACTION ID: SAW-2017-01232
NORTH CAROLINA DEPARTMENT OF TRANSPORTATION
I-74 WINSTON-SALEM NORTHERN BELTWAY TIP NO. U-2579C

and head cutting upstream should be considered in the placement of the culvert. The following pipes are exempt from this condition:

- site 6: 24-inch Reinforced Concrete Pipe (RCP) outlet at station 31 + 30-Y1-Rt
- site 7: 72-inch RCP inlet at station 413+74-L-Lt
- site 9: 78-inch CSP inlet at station 21+46-Y1RPD-Rt; 78-inch CSP at station 25+82-Y1RPD-Lt
- site 14: 42-inch RCP outlet at station 42+15-Y1-Rt

17. **AQUATIC PASSAGE:** Measures will be included in the construction/installation that will promote the safe passage of fish and other aquatic organisms. The dimension, pattern, and profile of the stream above and below a pipe or culvert should not be modified by widening the stream channel or by reducing the depth of the stream in connection with the construction activity. The width, height, and gradient of a proposed opening should be such as to pass the average historical low flow and spring flow without adversely altering flow velocity. Spring flow should be determined from gauge data, if available. In the absence of such data, bankfull flow can be used as a comparable level.

ESA

18. **THREATENED AND ENDANGERED SPECIES:** All necessary precautions and measures will be implemented so that any activity will not kill, injure, capture, harass, or otherwise harm any protected federally listed species. While accomplishing the authorized work, if the permittee discovers or observes a damaged or hurt listed endangered or threatened species, the District Engineer will be immediately notified to initiate the required Federal coordination.

SECTION 103

19. **UNKNOWN CULTURAL RESOURCES:** While accomplishing the authorized work, if the permittee discovers any previously unknown cultural resources, the District Engineer will be immediately notified so that required coordination can be initiated with the North Carolina Division of Cultural Resources.

ENFORCEMENT

20. **REPORTING ADDRESS:** All reports, documentation and correspondence required by the conditions of this permit shall be submitted to the following address: U.S. Army Corps of Engineers, Regulatory Division, Raleigh Regulatory Field Office, c/o Mr. James Lastinger, 3331 Heritage Trade Drive, Suite 105, Wake Forest, North Carolina 27587, and by telephone at: 919-554-4884, extension 32. The Permittee shall reference the following permit number, SAW-2017-01232, on all submittals.

SPECIAL CONDITIONS
ACTION ID: SAW-2017-01232
NORTH CAROLINA DEPARTMENT OF TRANSPORTATION
I-74 WINSTON-SALEM NORTHERN BELTWAY TIP NO. U-2579C

21. REPORTING VIOLATIONS OF THE CLEAN WATER ACT AND RIVERS AND HARBORS ACT: Violation of these conditions or violation of Section 404 of the Clean Water Act or Section 10 of the Rivers and Harbors Act must be reported in writing to the Wilmington District U.S. Army Corps of Engineers within 24 hours of the permittee's discovery of the violation.

22. COMPLIANCE INSPECTION: A representative of the Corps of Engineers will periodically and randomly inspect the work for compliance with these conditions. Deviations from these procedures may result in an administrative financial penalty and/or directive to cease work until the problem is resolved to the satisfaction of the Corps.

COMPENSATORY MITIGATION

23. In order to compensate for impacts associated with this permit, mitigation shall be provided in accordance with the provisions outlined on the most recent version of the attached Compensatory Mitigation Responsibility Transfer Form. The requirements of this form, including any special conditions listed on this form, are hereby incorporated as special conditions of this permit authorization. (See Exhibit B)

Wilmington District

Compensatory Mitigation Responsibility Transfer Form

Permittee: North Carolina Department of Transportation

Action ID: SAW-2017-01232

Project Name: U-2579C/Winston-Salem Northern Beltway/Forsyth/Div 9

County: Forsyth

Instructions to Permittee: The Permittee must provide a copy of this form to the Mitigation Sponsor, either an approved Mitigation Bank or the North Carolina Division of Mitigation Services (NCDMS), who will then sign the form to verify the transfer of the mitigation responsibility. Once the Sponsor has signed this form, it is the Permittee's responsibility to ensure that to the U.S. Army Corps of Engineers (USACE) Project Manager identified on page two is in receipt of a signed copy of this form before conducting authorized impacts, unless otherwise specified below. If more than one mitigation Sponsor will be used to provide the mitigation associated with the permit, or if the impacts and/or the mitigation will occur in more than one 8-digit Hydrologic Unit Code (HUC), multiple forms will be attached to the permit, and the separate forms for each Sponsor and/or HUC must be provided to the appropriate mitigation Sponsors.

Instructions to Sponsor: The Sponsor must verify that the mitigation requirements (credits) shown below are available at the identified site. By signing below, the Sponsor is accepting full responsibility for the identified mitigation, regardless of whether or not they have received payment from the Permittee. Once the form is signed, the Sponsor must update the bank ledger and provide a copy of the signed form and the updated bank ledger to the Permittee, the USACE Project Manager, and the Wilmington District Mitigation Office (see contact information on page 2). The Sponsor must also comply with all reporting requirements established in their authorizing instrument.

Permitted Impacts and Compensatory Mitigation Requirements:

Permitted Impacts Requiring Mitigation* 8-digit HUC and Basin: 03040101, Yadkin River Basin

Stream Impacts (linear feet)			Wetland Impacts (acres)			
Warm	Cool	Cold	Riparian Riverine	Riparian Non-Riverine	Non-Riparian	Coastal
921				0.88		

*If more than one mitigation sponsor will be used for the permit, only include impacts to be mitigated by this sponsor.

Compensatory Mitigation Requirements: 8-digit HUC and Basin: 03040101, Yadkin River Basin

Stream Mitigation (credits)			Wetland Mitigation (credits)			
Warm	Cool	Cold	Riparian Riverine	Riparian Non-Riverine	Non-Riparian	Coastal
1,842				1.76		

Mitigation Site Debited: NCDMS

(List the name of the bank to be debited. For umbrella banks, also list the specific site. For NCDMS, list NCDMS. If the NCDMS acceptance letter identifies a specific site, also list the specific site to be debited).

Section to be completed by the Mitigation Sponsor

Statement of Mitigation Liability Acceptance: I, the undersigned, verify that I am authorized to approve mitigation transactions for the Mitigation Sponsor shown below, and I certify that the Sponsor agrees to accept full responsibility for providing the mitigation identified in this document (see the table above), associated with the USACE Permittee and Action ID number shown. I also verify that released credits (and/or advance credits for NCDMS), as approved by the USACE, are currently available at the mitigation site identified above. Further, I understand that if the Sponsor fails to provide the required compensatory mitigation, the USACE Wilmington District Engineer may pursue measures against the Sponsor to ensure compliance associated with the mitigation requirements.

Mitigation Sponsor Name: _____

Name of Sponsor's Authorized Representative: _____

Signature of Sponsor's Authorized Representative

Date of Signature

**USACE Wilmington District
Compensatory Mitigation Responsibility Transfer Form, Page 2**

Conditions for Transfer of Compensatory Mitigation Credit:

- Once this document has been signed by the Mitigation Sponsor and the USACE is in receipt of the signed form, the Permittee is no longer responsible for providing the mitigation identified in this form, though the Permittee remains responsible for any other mitigation requirements stated in the permit conditions.
- Construction within jurisdictional areas authorized by the permit identified on page one of this form can begin only after the USACE is in receipt of a copy of this document signed by the Sponsor, confirming that the Sponsor has accepted responsibility for providing the mitigation requirements listed herein. For authorized impacts conducted by the North Carolina Department of Transportation (NCDOT), construction within jurisdictional areas may proceed upon permit issuance; however, a copy of this form signed by the Sponsor must be provided to the USACE within 30 days of permit issuance. NCDOT remains fully responsible for the mitigation until the USACE has received this form, confirming that the Sponsor has accepted responsibility for providing the mitigation requirements listed herein.
- Signed copies of this document must be retained by the Permittee, Mitigation Sponsor, and in the USACE administrative records for both the permit and the Bank/ILF Instrument. It is the Permittee's responsibility to ensure that the USACE Project Manager (address below) is provided with a signed copy of this form.
- If changes are proposed to the type, amount, or location of mitigation after this form has been signed and returned to the USACE, the Sponsor must obtain case-by-case approval from the USACE Project Manager and/or North Carolina Interagency Review Team (NCIRT). If approved, higher mitigation ratios may be applied, as per current District guidance and a new version of this form must be completed and included in the USACE administrative records for both the permit and the Bank/ILF Instrument.

Comments/Additional Conditions:

This form is not valid unless signed below by the USACE Project Manager and by the Mitigation Sponsor on Page 1. *Once signed, the Sponsor should provide copies of this form along with an updated bank ledger to: 1) the Permittee, 2) the USACE Project Manager at the address below, and 3) the Wilmington District Mitigation Office, Attn: Todd Tugwell, 3331 Heritage Trade Dr., suite 105, Wake Forest, NC 27587 (email: todd.tugwell@usace.army.mil).* Questions regarding this form or any of the permit conditions may be directed to the USACE Project Manager below.

USACE Project Manager: James Lastinger
USACE Field Office: Raleigh Regulatory Field Office
US Army Corps of Engineers
3331 Heritage Trade Drive, Suite 105
Wake Forest, North Carolina 27587

Email: james.c.lastinger@usace.army.mil



USACE Project Manager Signature

August 17, 2017

Date of Signature

Current Wilmington District mitigation guidance, including information on mitigation ratios, functional assessments, and mitigation bank location and availability, and credit classifications (including stream temperature and wetland groupings) is available at <http://ribits.usace.army.mil>.



ROY COOPER
Governor

MICHAEL S. REGAN
Secretary

S. JAY ZIMMERMAN
Director

July 26, 2017

Mr. Philip S. Harris, III, P.E., CPM
Natural Environment Section Head
Project Development and Environmental Analysis
North Carolina Department of Transportation
1598 Mail Service Center
Raleigh, North Carolina, 27699-1598

Subject: 401 Water Quality Certification Pursuant to Section 401 of the Federal Clean Water with ADDITIONAL CONDITIONS for proposed Winston Salem North Beltway (Eastern Section) from US 311 to US 158 in Forsyth County; Federal Aid Project No. NHP-0918(93); TIP No. U-2579C; WBS 4839.1.9. NCDWR Project No. 20170730.

Dear Mr. Harris:

Attached hereto is a copy of Certification No. WQC004123 issued to The North Carolina Department of Transportation (NCDOT) dated July 26, 2017.

If we can be of further assistance, do not hesitate to contact us.

Sincerely,

A handwritten signature in blue ink, appearing to read 'S. Jay Zimmerman', written over a faint, larger version of the same signature.

S. Jay Zimmerman, Director
Division of Water Resources

Attachments

Electronic copy only distribution:

James Lastinger, US Army Corps of Engineers, Raleigh Field Office
Amy Euliss, Division 9 Environmental Officer
Rodger Rochelle, NC Department of Transportation
Carla Dagnino, NC Department of Transportation
Chris Militscher, US Environmental Protection Agency
Marella Buncick, US Fish and Wildlife Service
Marla Chambers, NC Wildlife Resources Commission
Beth Harmon, Division of Mitigation Services
File Copy

**401 Water Quality Certification Pursuant to Section 401 of the Federal Clean Water Act with
ADDITIONAL CONDITIONS**

THIS CERTIFICATION is issued in conformity with the requirements of Section 401 Public Laws 92-500 and 95-217 of the United States and subject to the North Carolina Division of Water Resources (NCDWR) Regulations in 15 NCAC 2H .0500. This certification authorizes the NCDOT to impact 0.88 acres of jurisdictional wetlands and 1,196 linear feet of jurisdictional streams in Forsyth County. The project shall be constructed pursuant to the application dated received June 8, 2017. The authorized impacts are as described below:

Stream Impacts in the Yadkin Pee Dee River Basin

Site	Permanent Fill in Intermittent Stream (linear ft)	Permanent Fill in Perennial Stream (linear ft)			Temporary Fill in Perennial Stream (linear ft)	Total Stream Impact (linear ft)	Stream Impacts Requiring Mitigation (linear ft)
		Culvert	Channel Stabilization	Bank Stabilization			
6	68	-	-	-	-	68	-
7A	-	205	-	25	40	270	205
9	-	271	45	-	56	372	316
11	-	317	-	25	23	365	317
12	-	-	-	26	80	106	-
14	-	15	-	-	-	15	-
Total	68	808	45	76	199	1,196	838

Total Stream Impact for Project: 1,196 linear feet

Wetland Impacts in the Yadkin Pee Dee River Basin (riverine)

Site	Fill (ac)	Mechanized Clearing (ac)	Hand Clearing (ac)	Total Wetland Impact (ac)
7	<0.01	<0.01	-	<0.01
7A	0.14	-	-	0.14
11	0.08	0.03	-	0.11
13	0.57	0.05	-	0.65
Total	0.79	0.09	-	0.88

Total Wetland Impact for Project: 0.88 acres.

The application provides adequate assurance that the discharge of fill material into the waters of the Yadkin Pee Dee River Basin in conjunction with the proposed development will not result in a violation of applicable Water Quality Standards and discharge guidelines. Therefore, the State of North Carolina certifies that this activity will not violate the applicable portions of Sections 301, 302, 303, 306, 307 of PL 92-500 and PL 95-217 if conducted in accordance with the application and conditions hereinafter set forth.

This approval is only valid for the purpose and design that you submitted in your application dated June 8, 2017. Should your project change, you are required to notify the NCDWR and submit a new application. If the property is sold, the new owner must be given a copy of this Certification and approval letter, and is thereby responsible for complying with all the conditions. If any additional wetland impacts, or stream impacts, for this project (now or in the future) exceed one acre or 300 linear feet, respectively, additional compensatory mitigation may be required as described in 15A NCAC 2H .0506 (h) (6) and (7). For this approval to remain valid, you are required to comply with all the conditions listed below. In addition, you should obtain all other federal, state or local permits before proceeding with your project including (but not limited to) Sediment and Erosion control, Coastal Stormwater, Non-discharge and Water Supply watershed regulations. This Certification shall expire on the same day as the expiration date of the corresponding Corps of Engineers Permit.

Condition(s) of Certification:

Stream Mitigation

1. Compensatory mitigation for 838 linear feet of impact to streams is required. We understand that you have chosen to perform compensatory mitigation for impacts to streams through the North Carolina Division of Mitigation Service (DMS) (formerly NCEEP), and that the DMS has agreed to implement the mitigation for the project. The DMS has indicated in a letter dated June 2, 2017 that they will assume responsibility for satisfying the federal Clean Water Act compensatory mitigation requirements for the above-referenced project, in accordance with the DMS Mitigation Banking Instrument signed July 28, 2010.
2. Culverts, pipes and channel work shall be installed and constructed as described in the permit application. NCDWR shall be notified if culverts, pipes and channel work cannot be installed and constructed as described in the permit application. Culverts shall be designed to mimic natural stream cross section as closely as possible including flood plain elevations and/or sills and baffles where appropriate. Widening the stream channel should be avoided. [15A NCAC 02H.0506(b)(2)]
3. Riprap shall not be placed in the active thalweg channel or placed in the streambed in a manner that precludes aquatic life passage. Bioengineering boulders or structures should be properly designed, sized and installed as described in the permit application. [15A NCAC 02H.0506(b)(2)]
4. The stream channel shall be excavated no deeper than the natural bed material of the stream, to the maximum extent practicable. Efforts must be made to minimize impacts to the stream banks, as well as to vegetation responsible for maintaining the stream bank stability. [15A NCAC 02H.0506(b)(2)]
5. The post-construction removal of any temporary bridge structures must return the project site to its preconstruction contours and elevations. The impacted areas shall be revegetated with appropriate native species. [15A NCAC 02H .0506(b)(2)]
6. Bridge deck drains shall not discharge directly into the stream. Stormwater shall be directed across the bridge and pre-treated through site-appropriate means (grassed swales, pre-formed scour holes, vegetated buffers, etc.) as described in the permit application, before entering the stream. [15A NCAC 02H .0507(d)(2) and 15A NCAC 02H .0506(b)(5)]

General Conditions

1. If concrete is used during construction, a dry work area shall be maintained to prevent direct contact between curing concrete and stream water. Water that inadvertently contacts uncured concrete shall not be discharged to surface waters due to the potential for elevated pH and possible aquatic life and fish kills. [15A NCAC 02B.0200]

2. During the construction of the project, no staging of equipment of any kind is permitted in waters of the U.S., or protected riparian buffers. [15A NCAC 02H.0506(b)(2)]
3. The dimension, pattern and profile of the stream above and below the crossing shall not be modified. Disturbed floodplains and streams shall be restored to natural geomorphic conditions. [15A NCAC 02H.0506(b)(2)]
4. The use of rip-rap above the Normal High Water Mark shall be minimized. Any rip-rap placed for stream stabilization shall be placed in stream channels in such a manner that it does not impede aquatic life passage. [15A NCAC 02H.0506(b)(2)]
5. The Permittee shall ensure that the final design drawings adhere to the permit and to the permit drawings submitted for approval. [15A NCAC 02H .0507(c) and 15A NCAC 02H .0506 (b)(2) and (c)(2)]
6. All work in or adjacent to stream waters shall be conducted in a dry work area. Approved BMP measures from the most current version of NCDOT Construction and Maintenance Activities manual such as sandbags, rock berms, cofferdams and other diversion structures shall be used to prevent excavation in flowing water. [15A NCAC 02H.0506(b)(3) and (c)(3)]
7. Heavy equipment shall be operated from the banks rather than in the stream channel in order to minimize sedimentation and reduce the introduction of other pollutants into the stream. [15A NCAC 02H.0506(b)(3)]
8. All mechanized equipment operated near surface waters must be regularly inspected and maintained to prevent contamination of stream waters from fuels, lubricants, hydraulic fluids, or other toxic materials. [15A NCAC 02H.0506(b)(3)]
9. No rock, sand or other materials shall be dredged from the stream channel except where authorized by this certification. [15A NCAC 02H.0506(b)(3)]
10. Discharging hydroseed mixtures and washing out hydroseeders and other equipment in or adjacent to surface waters is prohibited. [15A NCAC 02H.0506(b)(3)]
11. The permittee and its authorized agents shall conduct its activities in a manner consistent with State water quality standards (including any requirements resulting from compliance with §303(d) of the Clean Water Act) and any other appropriate requirements of State and Federal law. If the NCDWR determines that such standards or laws are not being met (including the failure to sustain a designated or achieved use) or that State or federal law is being violated, or that further conditions are necessary to assure compliance, the NCDWR may reevaluate and modify this certification. [15A NCAC 02B.0200]
12. All fill slopes located in jurisdictional wetlands shall be placed at slopes no flatter than 3:1, unless otherwise authorized by this certification. [15A NCAC 02H.0506(b)(2)]
13. A copy of this Water Quality Certification shall be maintained on the construction site at all times. In addition, the Water Quality Certification and all subsequent modifications, if any, shall be maintained with the Division Engineer and the on-site project manager. [15A NCAC 02H .0507(c) and 15A NCAC 02H .0506 (b)(2) and (c)(2)]
14. The outside buffer, wetland or water boundary located within the construction corridor approved by this authorization shall be clearly marked by highly visible fencing or flagging prior to any land disturbing activities. Impacts to areas within the fencing are prohibited unless otherwise authorized by this certification. [15A NCAC 02H.0501 and .0502]
15. The issuance of this certification does not exempt the Permittee from complying with any and all statutes, rules, regulations, or ordinances that may be imposed by other government agencies (i.e. local, state, and federal) having jurisdiction, including but not limited to applicable buffer rules, stormwater management rules, soil erosion and sedimentation control requirements, etc.
16. The Permittee shall report any violations of this certification to the Division of Water Resources within 24 hours of discovery. [15A NCAC 02B.0506(b)(2)]

17. Upon completion of the project (including any impacts at associated borrow or waste sites), the NCDOT Division Engineer (or appointee) shall complete and return the enclosed "Certification of Completion Form" to notify the NCDWR when all work included in the 401 Certification has been completed. [15A NCAC 02H.0502(f)]
18. Native riparian vegetation must be reestablished in the riparian areas within the construction limits of the project by the end of the growing season following completion of construction. [15A NCAC 02B.0506(3)]
19. There shall be no excavation from, or waste disposal into, jurisdictional wetlands or waters associated with this permit without appropriate modification. Should waste or borrow sites, or access roads to waste or borrow sites, be located in wetlands or streams, compensatory mitigation will be required since that is a direct impact from road construction activities. [15A NCAC 02H.0506(b)(3) and (c)(3)]
20. Erosion and sediment control practices must be in full compliance with all specifications governing the proper design, installation and operation and maintenance of such Best Management Practices in order to protect surface waters standards [15A NCAC 02H.0506(b)(3) and (c)(3)]:
 - a. The erosion and sediment control measures for the project must be designed, installed, operated, and maintained in accordance with the most recent version of the *North Carolina Sediment and Erosion Control Planning and Design Manual*.
 - b. The design, installation, operation, and maintenance of the sediment and erosion control measures must be such that they equal, or exceed, the requirements specified in the most recent version of the *North Carolina Sediment and Erosion Control Manual*. The devices shall be maintained on all construction sites, borrow sites, and waste pile (spoil) projects, including contractor-owned or leased borrow pits associated with the project.
 - c. For borrow pit sites, the erosion and sediment control measures must be designed, installed, operated, and maintained in accordance with the most recent version of the *North Carolina Surface Mining Manual*.
 - d. The reclamation measures and implementation must comply with the reclamation in accordance with the requirements of the Sedimentation Pollution Control Act.
21. Sediment and erosion control measures shall not be placed in wetlands or waters unless otherwise approved by this Certification. [15A NCAC 02H.0506(b)(3) and (c)(3)]

Violations of any condition herein set forth may result in revocation of this Certification and may result in criminal and/or civil penalties. This Certification shall become null and void unless the above conditions are made conditions of the Federal 404 and/or Coastal Area Management Act Permit. This Certification shall expire upon the expiration of the 404 or CAMA permit.

If you wish to contest any statement in the attached Certification you must file a petition for an administrative hearing. You may obtain the petition form from the office of Administrative hearings. You must file the petition with the office of Administrative Hearings within sixty (60) days of receipt of this notice. A petition is considered filed when it is received in the office of Administrative Hearings during normal office hours. The Office of Administrative Hearings accepts filings Monday through Friday between the hours of 8:00am and 5:00pm, except for official state holidays. The original and one (1) copy of the petition must be filed with the Office of Administrative Hearings.

The petition may be faxed-provided the original and one copy of the document is received by the Office of Administrative Hearings within five (5) business days following the faxed transmission. The mailing address for the Office of Administrative Hearings is:

Office of Administrative Hearings
6714 Mail Service Center
Raleigh, NC 27699-6714
Telephone: (919) 431-3000, Facsimile: (919) 431-3100

A copy of the petition must also be served on DEQ as follows:

Mr. Bill Lane, General Counsel
Department of Environmental Quality
1601 Mail Service Center

This the 26th day of July 2017

DIVISION OF WATER RESOURCES

A handwritten signature in blue ink, appearing to read "S. Jay Zimmerman". The signature is fluid and cursive, with the first name being the most prominent.

S. Jay Zimmerman, Director

WQC No. WQC004123



North Carolina Department of Transportation

Highway Stormwater Program
STORMWATER MANAGEMENT PLAN
FOR NCDOT PROJECTS



(Version 2.07; Released October 2016)

WBS Element: 34839.1.9 TIP No.: U-2579C County(ies): Forsyth Page 1 of 4

General Project Information

WBS Element:	34839.1.9	TIP Number:	U-2579C	Project Type:	New Location	Date:	1/14/2017
NCDOT Contact:	Stephen Morgan, PE		Contractor / Designer:	Sungate Design Group			
Address:	Hydraulics Unit 1590 Mail Service Center Raleigh, NC 27699-1590		Address:	905 Jones Franklin Rd Raleigh, NC 27606			
	Phone:	(919) 707-6739		Phone:	(919) 859-2243		
	Email:	smorgan@ncdot.gov		Email:	belam@sungatedesign.com		
City/Town:	Winston Salem		County(ies):	Forsyth			
River Basin(s):	Yadkin-Pee Dee		CAMA County?	No			
Wetlands within Project Limits?	Yes						

Project Description

Project Length (lin. miles or feet):	1.99	Surrounding Land Use:	Residential, Agricultural, Rural					
	Proposed Project		Existing Site					
Project Built-Upon Area (ac.)	43.6	ac.	5.8	ac.				
Typical Cross Section Description:	Three 12ft lanes with 14ft outside shoulders (12ft paved) and 12ft paved inside shoulders in each direction with a 22ft grassed median.		N/A					
Annual Avg Daily Traffic (veh/hr/day):	Design/Future:	81,670	Year:	2037	Existing:	65,592	Year:	2017
General Project Narrative: (Description of Minimization of Water Quality Impacts)	I-74 Winston-Salem Northern Beltway from East of US 311 to US 158: Measures have been taken throughout the project to limit impacts to wetlands and surface waters. Two Dry Detention basins will be utilized in the gore areas between the -L- line and Ramps B and C. These basins will serve to attenuate peak stormwater flows, promote settlement of suspended solids and reduce erosive velocities downstream. Further, no deck drains will be used on the Lowery Mill Creek bridge, eliminating potential for direct roadway runoff into surface waters. A rip rap energy dissipator basin will be used at storm drain system outlet, in the Lowery Mill Creek floodplain, to reduce peak flow velocities to Lowery Mill Creek. 2:1 slopes will be used in fill areas to reduce impacts to surrounding wetlands and jurisdictional streams.							

Waterbody Information

Surface Water Body (1):	Lowery Mill Creek		NCDWR Stream Index No.:	12-94-12-3-(0.5)				
NCDWR Surface Water Classification for Water Body	Primary Classification:		Water Supply III (WS-III)					
	Supplemental Classification:							
Other Stream Classification:								
Impairments:	None							
Aquatic T&E Species?	No	Comments:						
NRTR Stream ID:						Buffer Rules in Effect:	N/A	
Project Includes Bridge Spanning Water Body?	Yes	Deck Drains Discharge Over Buffer?	No	Dissipator Pads Provided in Buffer?				N/A
Deck Drains Discharge Over Water Body?	No	(If yes, provide justification in the General Project Narrative)			(If yes, describe in the General Project Narrative; if no, justify in the General Project Narrative)			
(If yes, provide justification in the General Project Narrative)								



North Carolina Department of Transportation
 Highway Stormwater Program
STORMWATER MANAGEMENT PLAN
 FOR NCDOT PROJECTS



(Version 2.07; Released October 2016)

WBS Element: 34839.1.9 **TIP No.:** U-2579C **County(ies):** Forsyth **Page** 2 **of** 4

Additional Waterbody Information

Surface Water Body (2):	Frazier Creek		NCDWR Stream Index No.:	12-94-12-6-1	
NCDWR Surface Water Classification for Water Body	Primary Classification:		Class C		
	Supplemental Classification:				
Other Stream Classification:					
Impairments:	None				
Aquatic T&E Species?	No	Comments:			
NRTR Stream ID:				Buffer Rules in Effect:	N/A
Project Includes Bridge Spanning Water Body?	No	Deck Drains Discharge Over Buffer?	N/A	Dissipator Pads Provided in Buffer?	
Deck Drains Discharge Over Water Body?	N/A	(If yes, provide justification in the General Project Narrative)		(If yes, describe in the General Project Narrative; if no, justify in the General Project Narrative)	
(If yes, provide justification in the General Project Narrative)					

Surface Water Body (3):			NCDWR Stream Index No.:		
NCDWR Surface Water Classification for Water Body	Primary Classification:				
	Supplemental Classification:				
Other Stream Classification:					
Impairments:					
Aquatic T&E Species?		Comments:			
NRTR Stream ID:				Buffer Rules in Effect:	
Project Includes Bridge Spanning Water Body?		Deck Drains Discharge Over Buffer?		Dissipator Pads Provided in Buffer?	
Deck Drains Discharge Over Water Body?		(If yes, provide justification in the General Project Narrative)		(If yes, describe in the General Project Narrative; if no, justify in the General Project Narrative)	
(If yes, provide justification in the General Project Narrative)					

Surface Water Body (4):			NCDWR Stream Index No.:		
NCDWR Surface Water Classification for Water Body	Primary Classification:				
	Supplemental Classification:				
Other Stream Classification:					
Impairments:					
Aquatic T&E Species?		Comments:			
NRTR Stream ID:				Buffer Rules in Effect:	
Project Includes Bridge Spanning Water Body?		Deck Drains Discharge Over Buffer?		Dissipator Pads Provided in Buffer?	
Deck Drains Discharge Over Water Body?		(If yes, provide justification in the General Project Narrative)		(If yes, describe in the General Project Narrative; if no, justify in the General Project Narrative)	
(If yes, provide justification in the General Project Narrative)					

Surface Water Body (5):			NCDWR Stream Index No.:		
NCDWR Surface Water Classification for Water Body	Primary Classification:				
	Supplemental Classification:				
Other Stream Classification:					
Impairments:					
Aquatic T&E Species?		Comments:			
NRTR Stream ID:				Buffer Rules in Effect:	
Project Includes Bridge Spanning Water Body?		Deck Drains Discharge Over Buffer?		Dissipator Pads Provided in Buffer?	
Deck Drains Discharge Over Water Body?		(If yes, provide justification in the General Project Narrative)		(If yes, describe in the General Project Narrative; if no, justify in the General Project Narrative)	
(If yes, provide justification in the General Project Narrative)					

09/08/99

See Sheet 1A For Index of Sheets
See Sheet 1B For Conventional Symbols

STATE OF NORTH CAROLINA DIVISION OF HIGHWAYS FORSYTH COUNTY

STATE	STATE PROJECT REFERENCE NO.	SHEET NO.	TOTAL SHEETS
N.C.	U-2579C	1	
STATE PROJ. NO.	F.A. PROJ. NO.	DESCRIPTION	
34839.1.9	N/A	PE	
34839.2.6	N/A	RW	
34839.2.GV18	N/A	RW	
34839.2.16	N/A	UTIL	
34839.3.GV6	NHP-0918(062)	CONSTR.	

TIP PROJECT: U-2579C

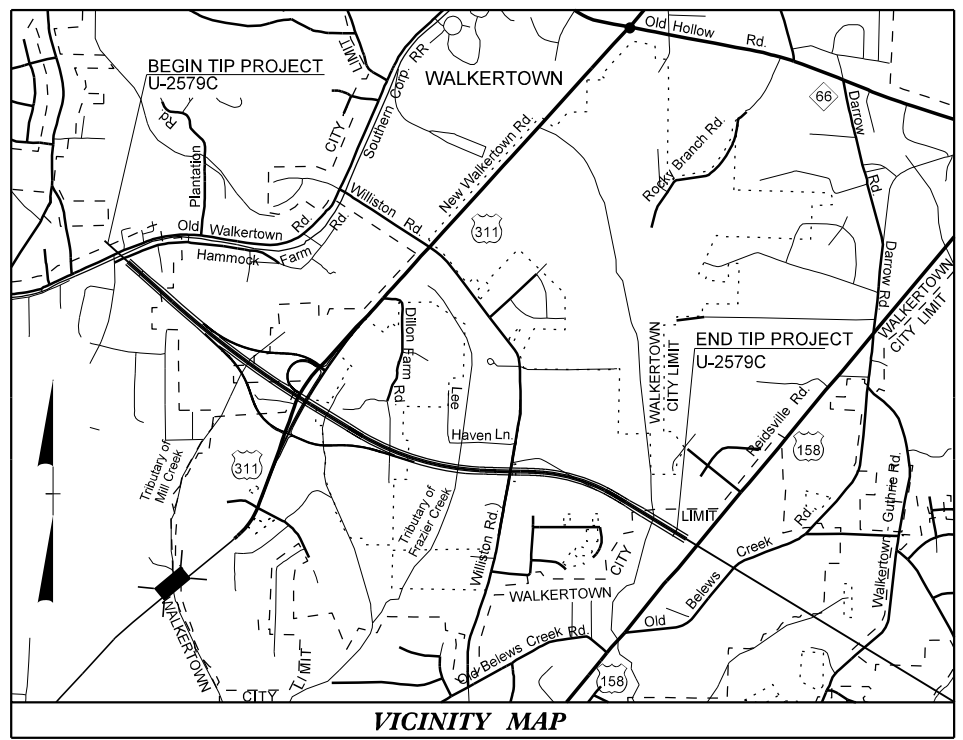

**LOCATION: WINSTON - SALEM NORTHERN BELTWAY (EASTERN SECTION)
FROM US 311 TO US 158 (FUTURE I-74)**

**TYPE OF WORK: WIDENING, GRADING, PAVING, DRAINAGE, SIGNING, SIGNALS,
ITS, CULVERTS AND STRUCTURES.**

WETLAND AND SURFACE WATER IMPACTS PERMIT

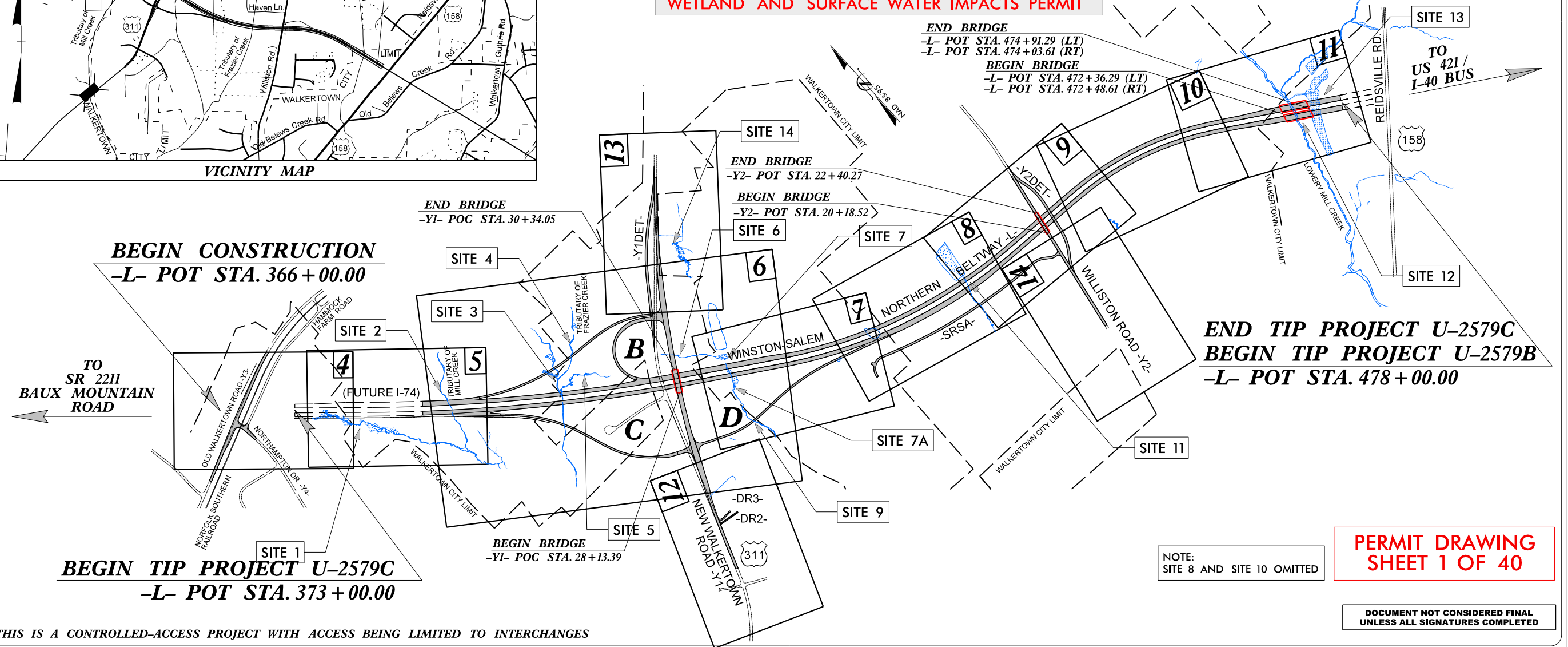

CONTRACT:

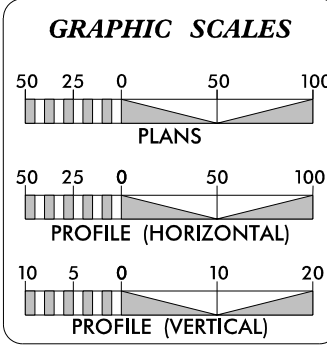

DESIGN DATA

ADT 2017 =	65,592
ADT 2037 =	93,112
K =	10 %
D =	60 %
T =	18 % *
V =	70 MPH
*(TTST=12% + DUAL=6%)	
FUNC CLASS =	INTERSTATE

PROJECT LENGTH

LENGTH OF ROADWAY PROJECT U-2579C	=	1.989 Miles
LENGTH OF STRUCTURE PROJECT U-2579C	=	0.040 Mile
TOTAL LENGTH OF TIP PROJECT U-2579C	=	1.949 Miles

PLANS PREPARED BY:
&
8601 SIX FORKS RD, SUITE 260
RALEIGH, NC 27615
919-926-4100

FOR THE NORTH CAROLINA DEPARTMENT OF TRANSPORTATION
2012 STANDARD SPECIFICATIONS

RIGHT OF WAY DATE:
OCTOBER 28, 2015

LETTING DATE:
OCTOBER 17, 2017

JASON TALLEY, PE
PROJECT ENGINEER

JARED BOND, PE
PROJECT DESIGN ENGINEER

TATIA L. WHITE, PE, PLS
NCDOT CONTACT

NOTE:
SITE 8 AND SITE 10 OMITTED

**PERMIT DRAWING
SHEET 1 OF 40**

DOCUMENT NOT CONSIDERED FINAL
UNLESS ALL SIGNATURES COMPLETED

HYDRAULICS ENGINEER

ROADWAY DESIGN ENGINEER

**DIVISION OF HIGHWAYS
STATE OF NORTH CAROLINA**

5/19/2017
U2579C_Hyd-prm_wet_01.dgn
belam

**PERMIT DRAWING
SHEET 2 OF 40**

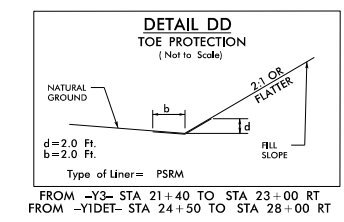
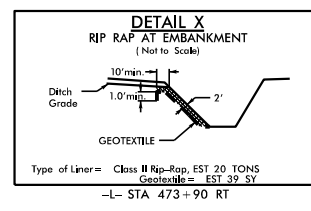
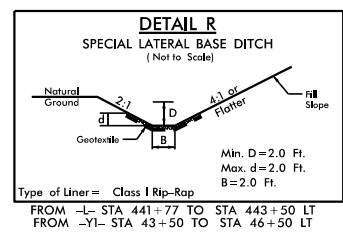
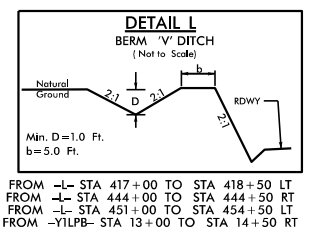
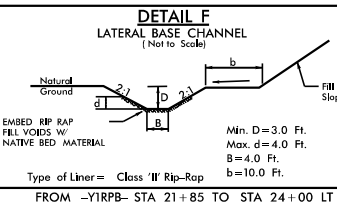
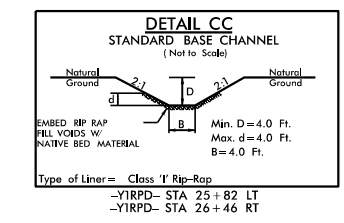
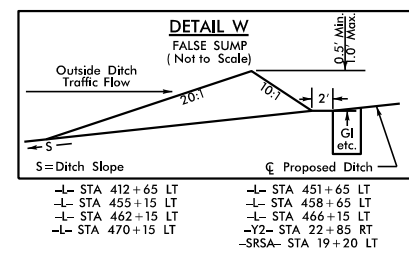
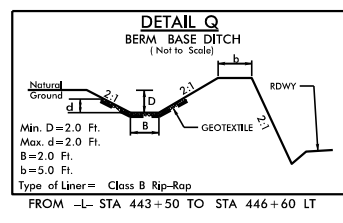
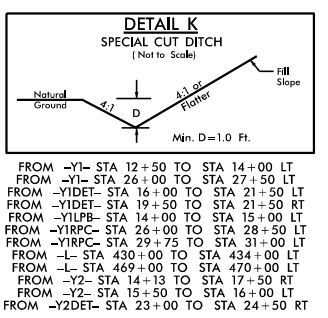
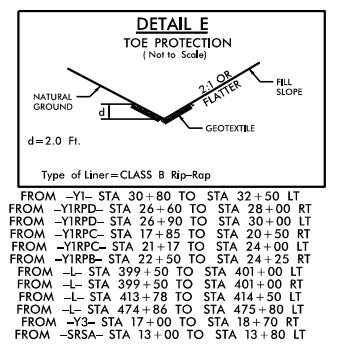
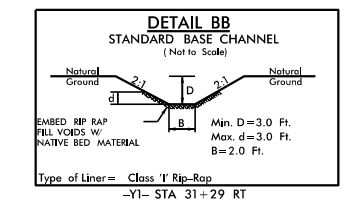
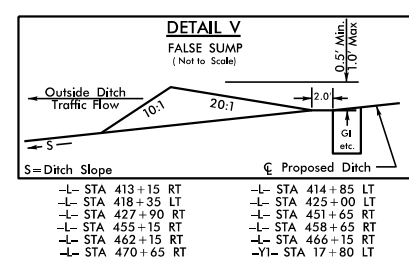
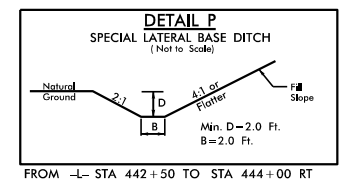
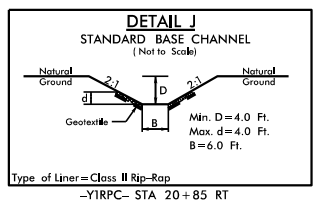
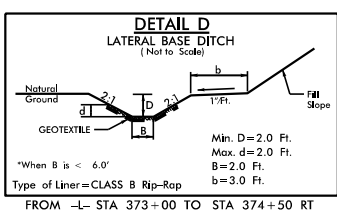
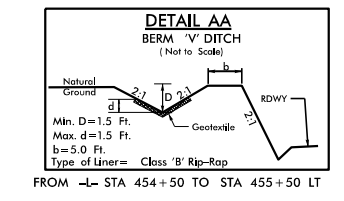
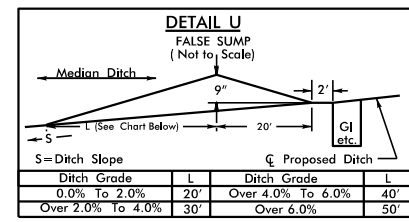
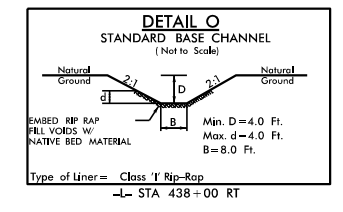
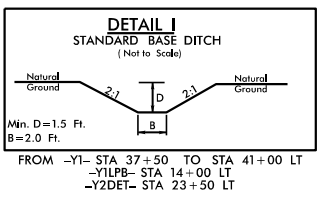
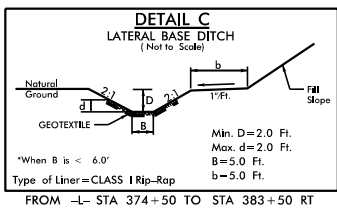
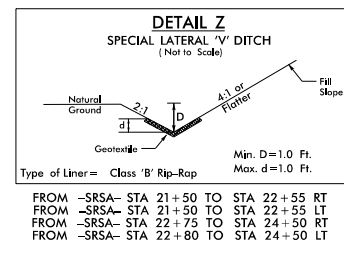
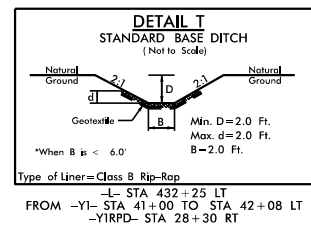
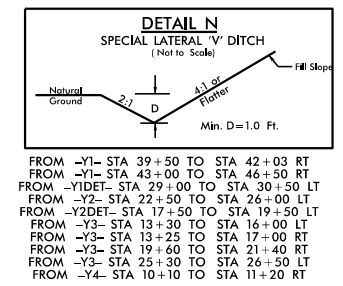
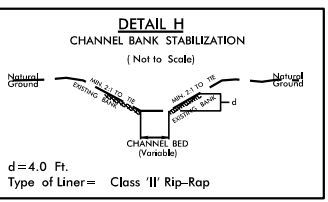
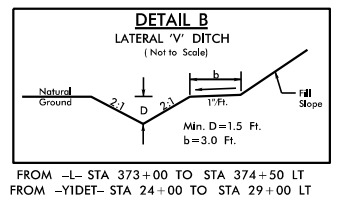
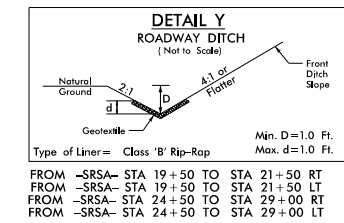
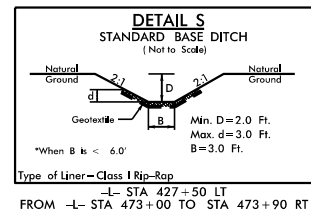
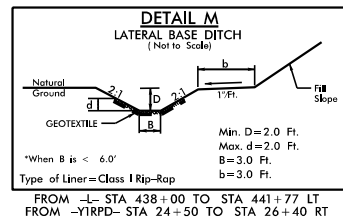
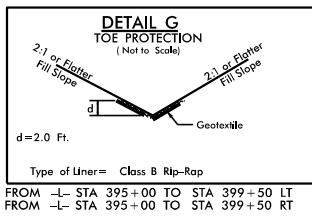
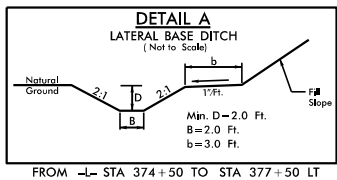

5/14/99 U:\36\proj\hyd-prm-wet-psh_03.dgn

PROJECT REFERENCE NO. U-2579C	SHEET NO. 2D-2
RW SHEET NO.	
ROADWAY DESIGN ENGINEER	HYDRAULICS ENGINEER

DOCUMENT NOT CONSIDERED FINAL UNLESS ALL SIGNATURES COMPLETED

PERMIT DRAWING SHEET 3 OF 40

DETAIL EE
DRY DETENTION BASIN DRAWDOWN STRUCTURE
NOT TO SCALE

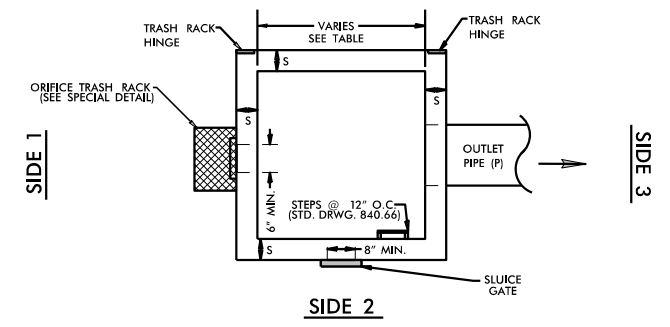
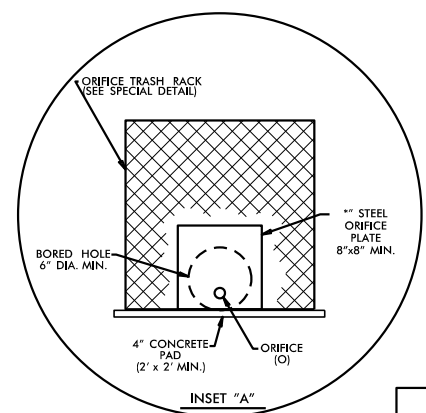
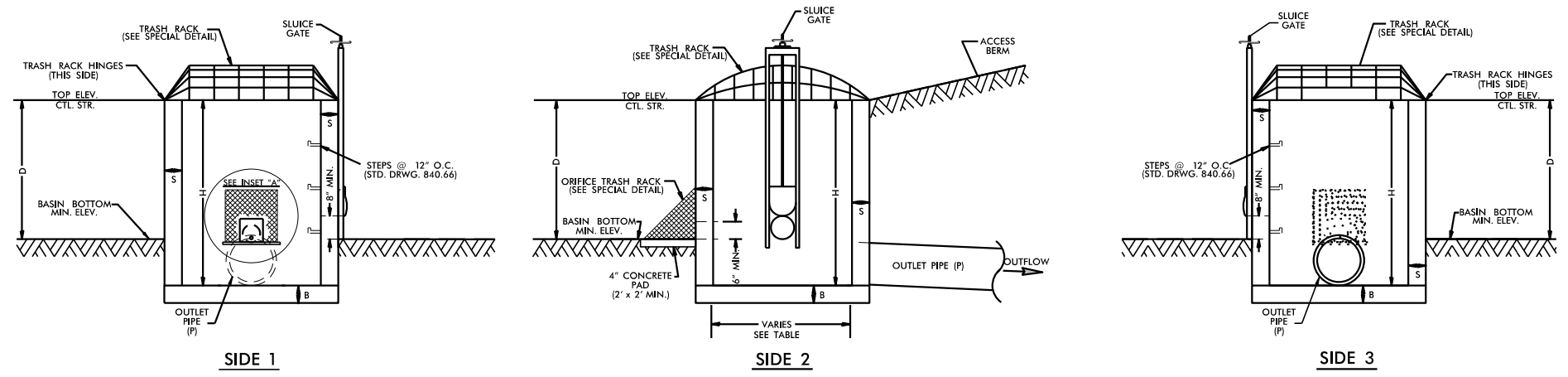

- NOTES:
1. TOP ELEVATION OF CONTROL STRUCTURE (WEIR ELEVATION) SHOULD BE SET AT THE WOGV ELEVATION.
 2. 15\"/>

PLAN VIEW
TRASH RACK NOT SHOWN FOR CLARITY

MINIMUM DIMENSIONS FOR DRY DETENTION BASIN DRAWDOWN STRUCTURE											
STATION	STRUCTURE NUMBER	S (INCHES) 6\"/>									
400+00 -L- LT	0623	6\"/>									
400+08 -L- RT	0609	6\"/>									

5/14/99

PROJECT REFERENCE NO. U-2579C	SHEET NO. 2D-3
RW SHEET NO.	
ROADWAY DESIGN ENGINEER	HYDRAULICS ENGINEER
DOCUMENT NOT CONSIDERED FINAL UNLESS ALL SIGNATURES COMPLETED	

PERMIT DRAWING
SHEET 4 OF 40

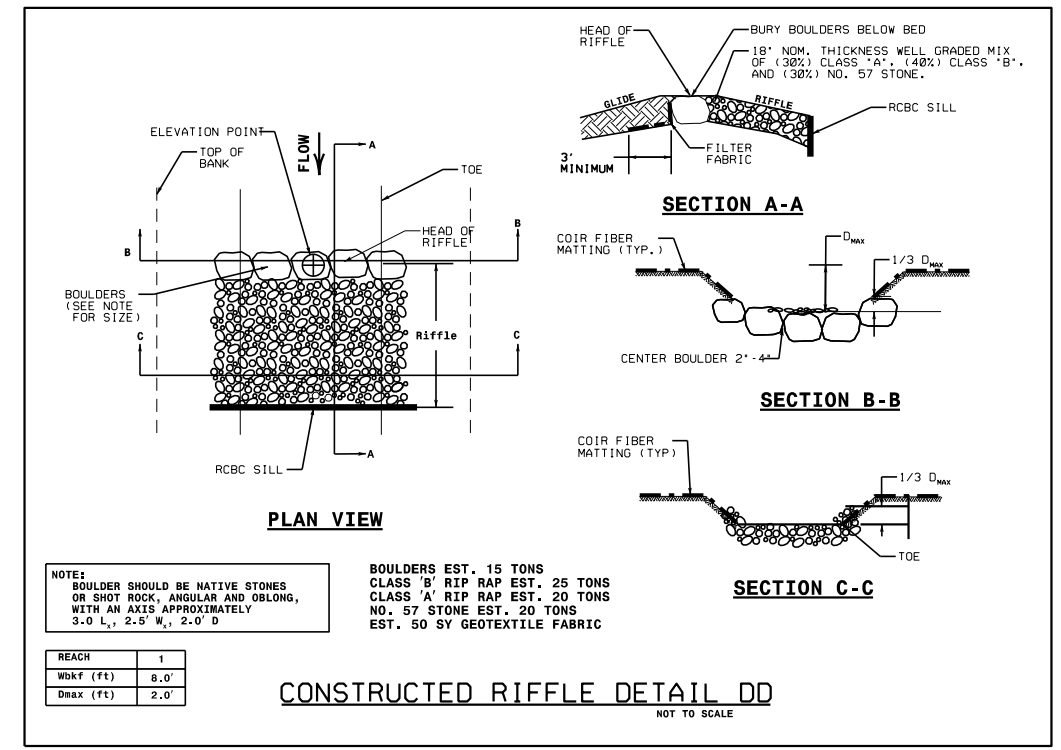
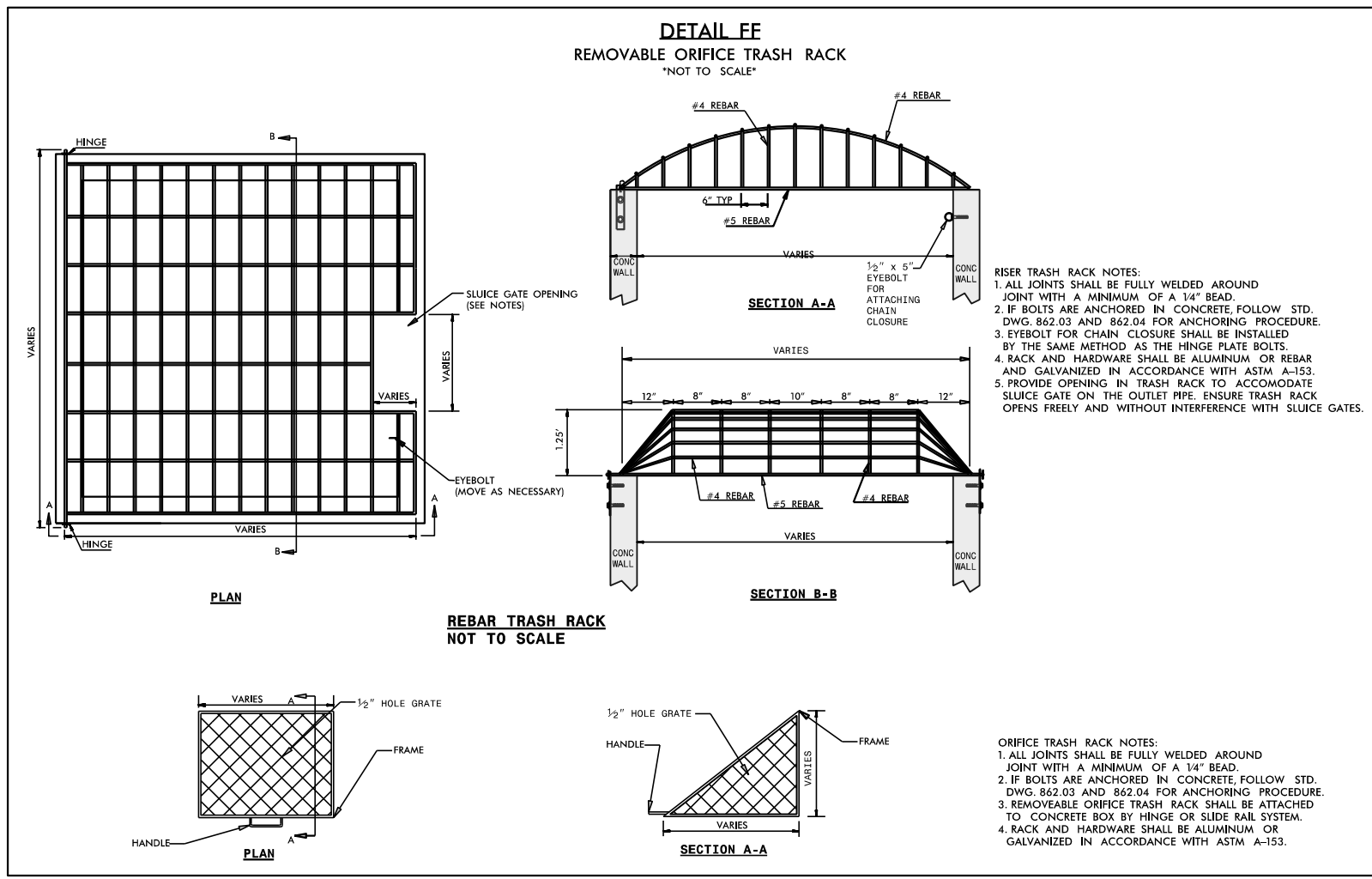

U2579C.dwg, pr-m, wet, psh, 03b.dgn
5/18/2017 10:11:11 AM

**DOCUMENT NOT CONSIDERED FINAL
UNLESS ALL SIGNATURES COMPLETED**

**PERMIT DRAWING
SHEET 5 OF 40**

DETAIL HH (NOT TO SCALE)

SINGLE BARREL CULVERT W/SILLS AND BAFFLES

*NOTES:

- 1) NATIVE BED MATERIAL SHALL BE PLACED BETWEEN THE SILLS IN THE CULVERT. NATIVE MATERIALS CONSISTS OF MATERIAL THAT IS EXCAVATED FROM THE STREAM BED OR FLOODPLAIN AT THE PROJECT SITE DURING CULVERT CONSTRUCTION. RIP RAP MAY BE USED TO SUPPLEMENT THE NATIVE MATERIAL. IF RIP RAP IS USED, NATIVE MATERIAL SHOULD BE PLACED ON TOP TO FACILITATE ANIMAL PASSAGE. THE TOP SURFACE OF THE NATURAL STREAM BED MATERIAL SHALL BE PLACED AND LEVELED TO A FLAT SURFACE TO ALLOW FOR ANIMAL PASSAGE. NATIVE MATERIAL AND RIP RAP ARE SUBJECT TO APPROVAL BY THE ENGINEER AND MAY BE SUBJECT TO PERMIT CONDITIONS.
- 2) SILLS/BAFFLES ARE TO BE 1.0 FT. WIDE, CAST SEPARATELY AND ATTACHED BY DOWELS.
- 3) TOP OF SILLS/BAFFLES SHOULD MATCH STREAM BED ELEVATION IN LOW FLOW CHANNEL OF STREAM. (THALWEG)
- 4) DO NOT SET ELEVATION OF SILLS/BAFFLES ABOVE BANK FULL.
- 5) NUMBER OF SILLS/BAFFLES DETERMINED BY THE ENGINEER.

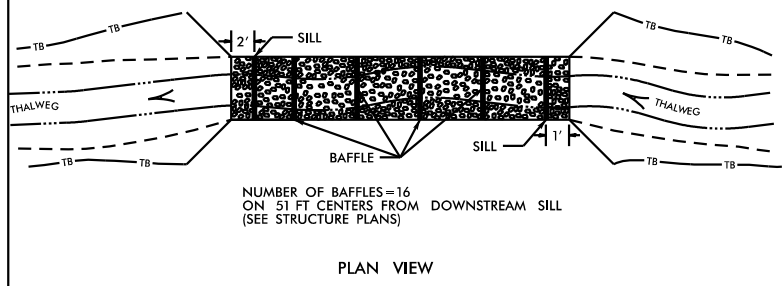
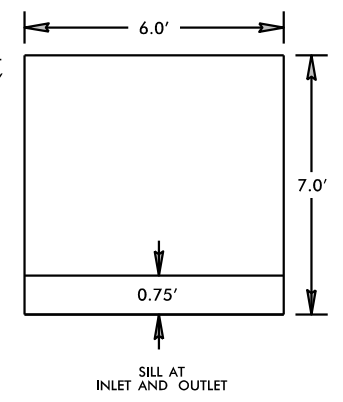

6' X 7' RCBC AT -L- STA 397+73

DETAIL II (NOT TO SCALE)

SINGLE BARREL CULVERT W/SILLS

*NOTES:

- 1) NATIVE BED MATERIAL SHALL BE PLACED BETWEEN THE SILLS IN THE CULVERT. NATIVE MATERIALS CONSISTS OF MATERIAL THAT IS EXCAVATED FROM THE STREAM BED OR FLOODPLAIN AT THE PROJECT SITE DURING CULVERT CONSTRUCTION. RIP RAP MAY BE USED TO SUPPLEMENT THE NATIVE MATERIAL. IF RIP RAP IS USED, NATIVE MATERIAL SHOULD BE PLACED ON TOP TO FACILITATE ANIMAL PASSAGE. THE TOP SURFACE OF THE NATURAL STREAM BED MATERIAL SHALL BE PLACED AND LEVELED TO A FLAT SURFACE TO ALLOW FOR ANIMAL PASSAGE. NATIVE MATERIAL AND RIP RAP ARE SUBJECT TO APPROVAL BY THE ENGINEER AND MAY BE SUBJECT TO PERMIT CONDITIONS.
- 2) SILLS/BAFFLES ARE TO BE 1.0 FT. WIDE, CAST SEPARATELY AND ATTACHED BY DOWELS.
- 3) TOP OF SILLS/BAFFLES SHOULD MATCH STREAM BED ELEVATION IN LOW FLOW CHANNEL OF STREAM. (THALWEG)
- 4) DO NOT SET ELEVATION OF SILLS/BAFFLES ABOVE BANK FULL.

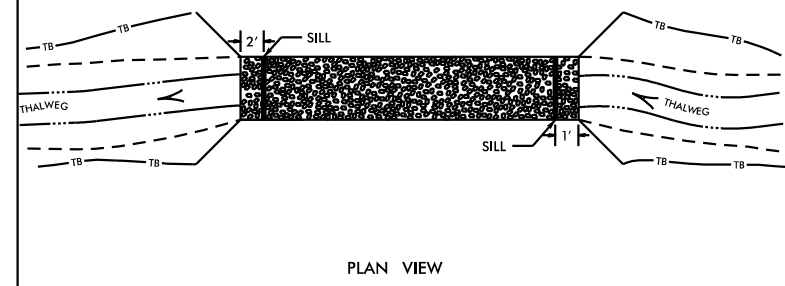
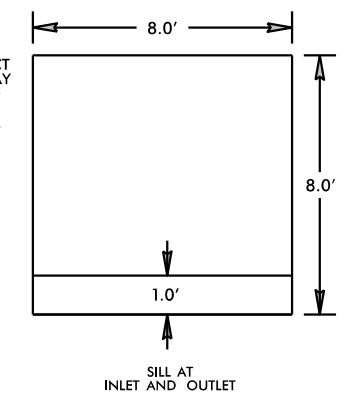

8' X 8' RCBC AT -L- STA 437+97

DETAIL JJ (Not to Scale)

DECK DRAIN DISSIPATOR PAD

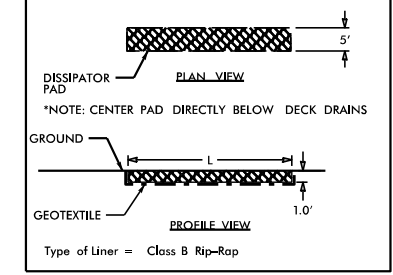

FROM -L- STA 472+52 TO STA 472+74 LT
FROM -L- STA 472+96 TO STA 473+08 RT
FROM -L- STA 473+85 TO STA 474+43 LT
FROM -L- STA 474+29 TO STA 474+90 RT

DETAIL LL (Not to Scale)

LATERAL BASE DITCH

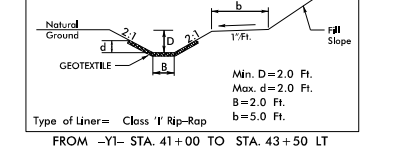

FROM -Y1- STA. 41+00 TO STA. 43+50 LT

DETAIL KK RIP-RAPPED ENERGY DISSIPATOR BASIN

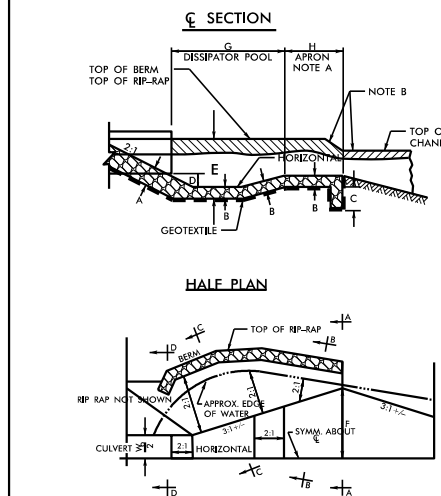

*NOTE A: IF EXIT VELOCITY OF BASIN IS SPECIFIED, EXTEND BASIN AS REQUIRED TO OBTAIN SUFFICIENT CROSS SECTIONAL AREA AT SECTION A-A SUCH THAT $Q_{des}/(CROSS SECTION AREA AT SEC. A-A) = SPECIFIED VELOCITY$.

*NOTE B: WARP BASIN TO CONFORM TO NATURAL STREAM CHANNEL. TOP OF RIP-RAP IN FLOOR OF BASIN SHOULD BE AT SAME ELEVATION OR LOWER THAN NATURAL CHANNEL BOTTOM AT SEC. A-A. PROVIDE SMOOTH TRANSITION FROM END OF APRON TO NATURAL CHANNEL WIDTH.

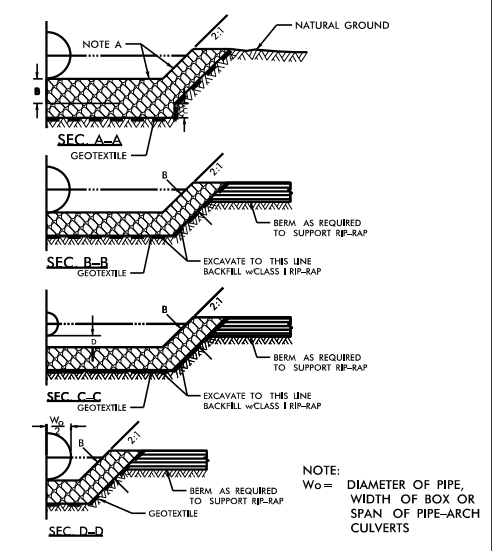

DIM.	1	2	3	4	5	6	7	8
A	2'							
B	2'							
C	2'							
D	2'							
E	7'							
F	12'							
G	20'							
H	10'							

CLASS 'Y' RIP RAP
EST. 105 TONS
EST. 190 SY GEOTEXTILE FABRIC

NOTE:
W₀ = DIAMETER OF PIPE,
WIDTH OF BOX OR
SPAN OF PIPE-ARCH
CULVERTS

*ALL DIMENSIONS APPROXIMATE IN FEET

PROJECT REFERENCE NO.	SHEET NO.
U-2579C	6
RW SHEET NO.	
ROADWAY DESIGN ENGINEER	HYDRAULICS ENGINEER

**PERMIT DRAWING
SHEET 14 OF 40**

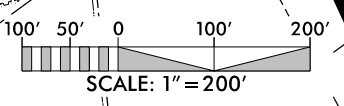

- DENOTES FILL IN WETLAND
- DENOTES IMPACTS IN SURFACE WATER
- DENOTES TEMPORARY IMPACTS IN SURFACE WATER
- DENOTES EXCAVATION IN WETLAND
- DENOTES MECHANIZED CLEARING

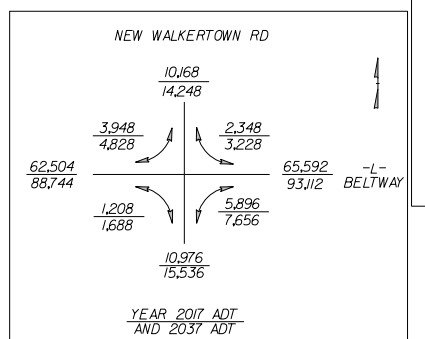
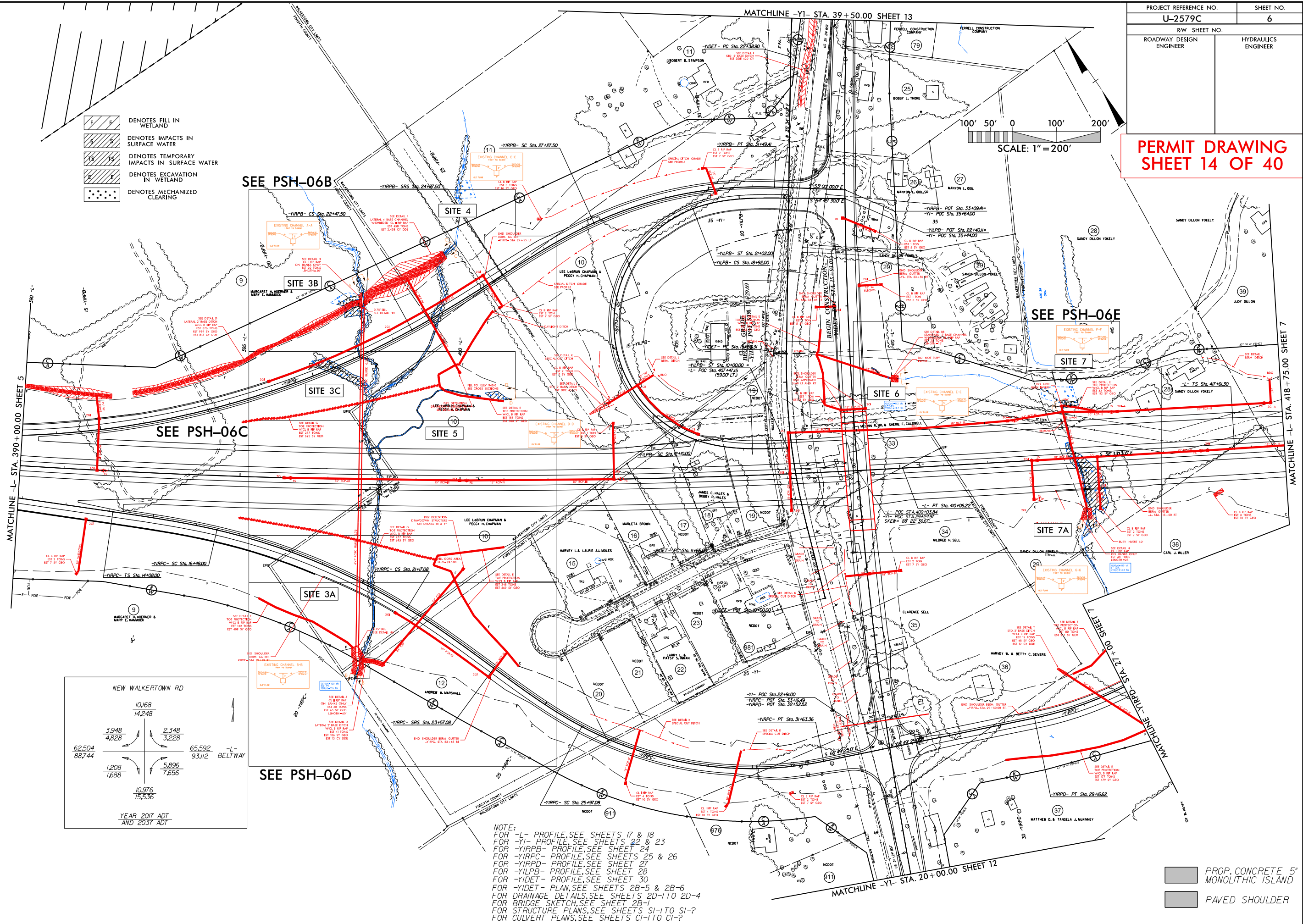





NOTE:
 FOR -L- PROFILE, SEE SHEETS 17 & 18
 FOR -YI- PROFILE, SEE SHEETS 22 & 23
 FOR -YIRPB- PROFILE, SEE SHEET 24
 FOR -YIRPC- PROFILE, SEE SHEETS 25 & 26
 FOR -YIRPD- PROFILE, SEE SHEET 27
 FOR -YILPB- PROFILE, SEE SHEET 28
 FOR -YIDET- PROFILE, SEE SHEET 30
 FOR -YIDET- PLAN, SEE SHEETS 2B-5 & 2B-6
 FOR DRAINAGE DETAILS, SEE SHEETS 2D-1 TO 2D-4
 FOR BRIDGE SKETCH, SEE SHEET 2B-1
 FOR STRUCTURE PLANS, SEE SHEETS S1-1 TO S1-7
 FOR CULVERT PLANS, SEE SHEETS C1-1 TO C1-7

- PROP. CONCRETE 5' MONOLITHIC ISLAND
- PAVED SHOULDER

8/17/99
6/5/2017_Hyd_prm_wet_psh_06.dgn

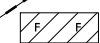
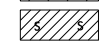
PROJECT REFERENCE NO.	SHEET NO.
U-2579C	6
RW SHEET NO.	
ROADWAY DESIGN ENGINEER	HYDRAULICS ENGINEER

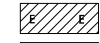
**PERMIT DRAWING
SHEET 15 OF 40**

-  DENOTES FILL IN WETLAND
-  DENOTES IMPACTS IN SURFACE WATER
-  DENOTES TEMPORARY IMPACTS IN SURFACE WATER
-  DENOTES EXCAVATION IN WETLAND
-  DENOTES MECHANIZED CLEARING

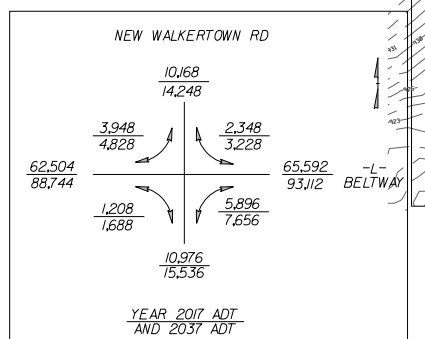
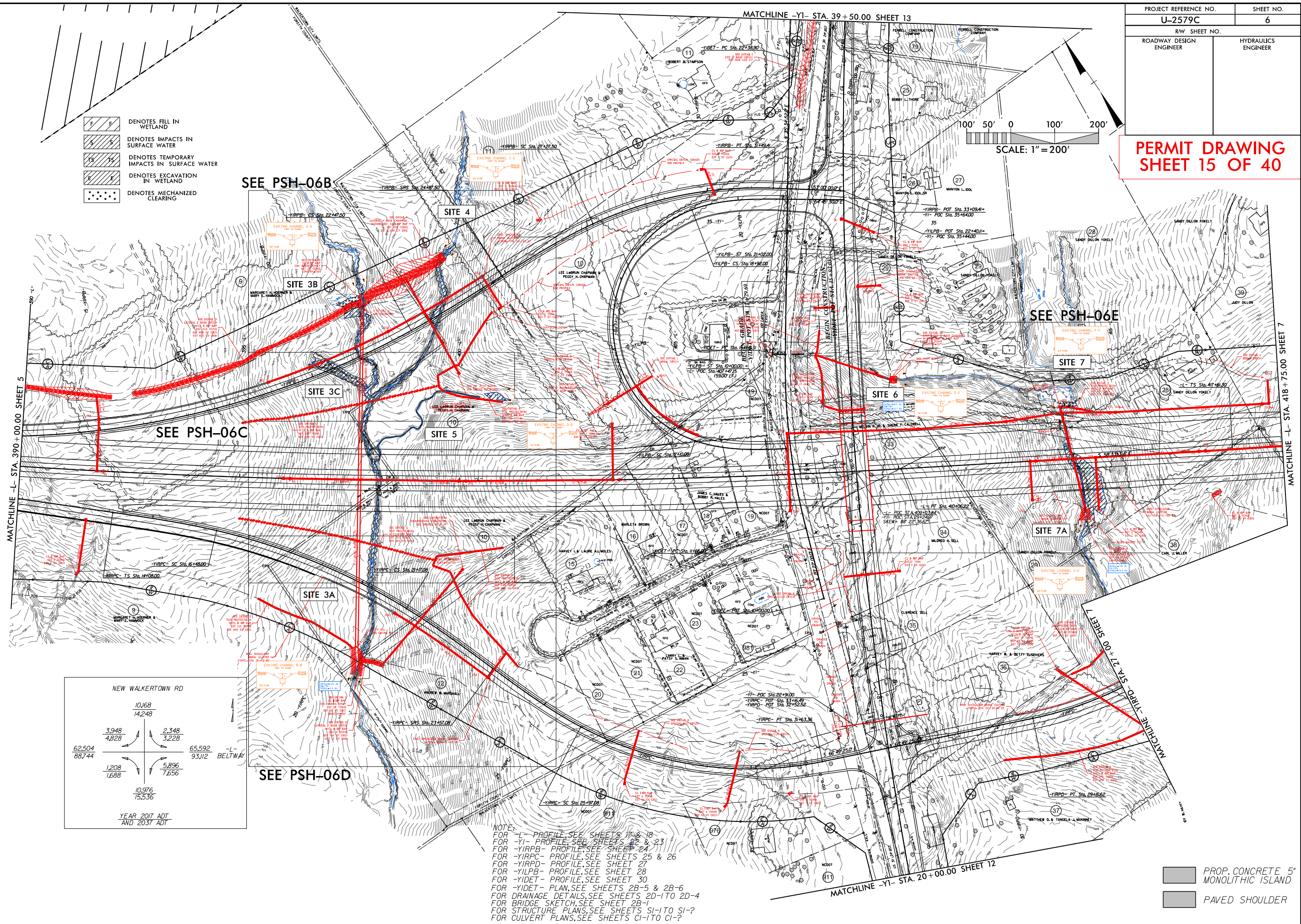
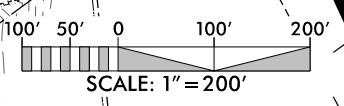

NOTE:
 FOR -L- PROFILE, SEE SHEETS 17 & 18
 FOR -Y1- PROFILE, SEE SHEETS 22 & 23
 FOR -YIRPB- PROFILE, SEE SHEETS 24
 FOR -YIRPC- PROFILE, SEE SHEETS 25 & 26
 FOR -YIRPD- PROFILE, SEE SHEET 27
 FOR -YILPB- PROFILE, SEE SHEET 28
 FOR -YIDET- PROFILE, SEE SHEET 30
 FOR -YIDET- PLAN, SEE SHEETS 2B-5 & 2B-6
 FOR DRAINAGE DETAILS, SEE SHEETS 2D-1 TO 2D-4
 FOR BRIDGE SKETCH, SEE SHEET 2B-1
 FOR STRUCTURE PLANS, SEE SHEETS S1-1 TO S1-7
 FOR CULVERT PLANS, SEE SHEETS C1-1 TO C1-7

-  PROP. CONCRETE 5' MONOLITHIC ISLAND
-  PAVED SHOULDER

8/17/99
6/5/2017 Hyd_prm_wet_psh_06a.dgn

8/17/99

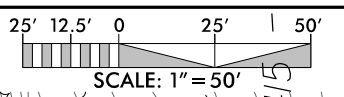

PROJECT REFERENCE NO. R-2579C	SHEET NO. 6E
RW SHEET NO.	
ROADWAY DESIGN ENGINEER	HYDRAULICS ENGINEER
INCOMPLETE PLANS DO NOT USE FOR A/W ACQUISITION	

PERMIT DRAWING
SHEET 19 OF 40

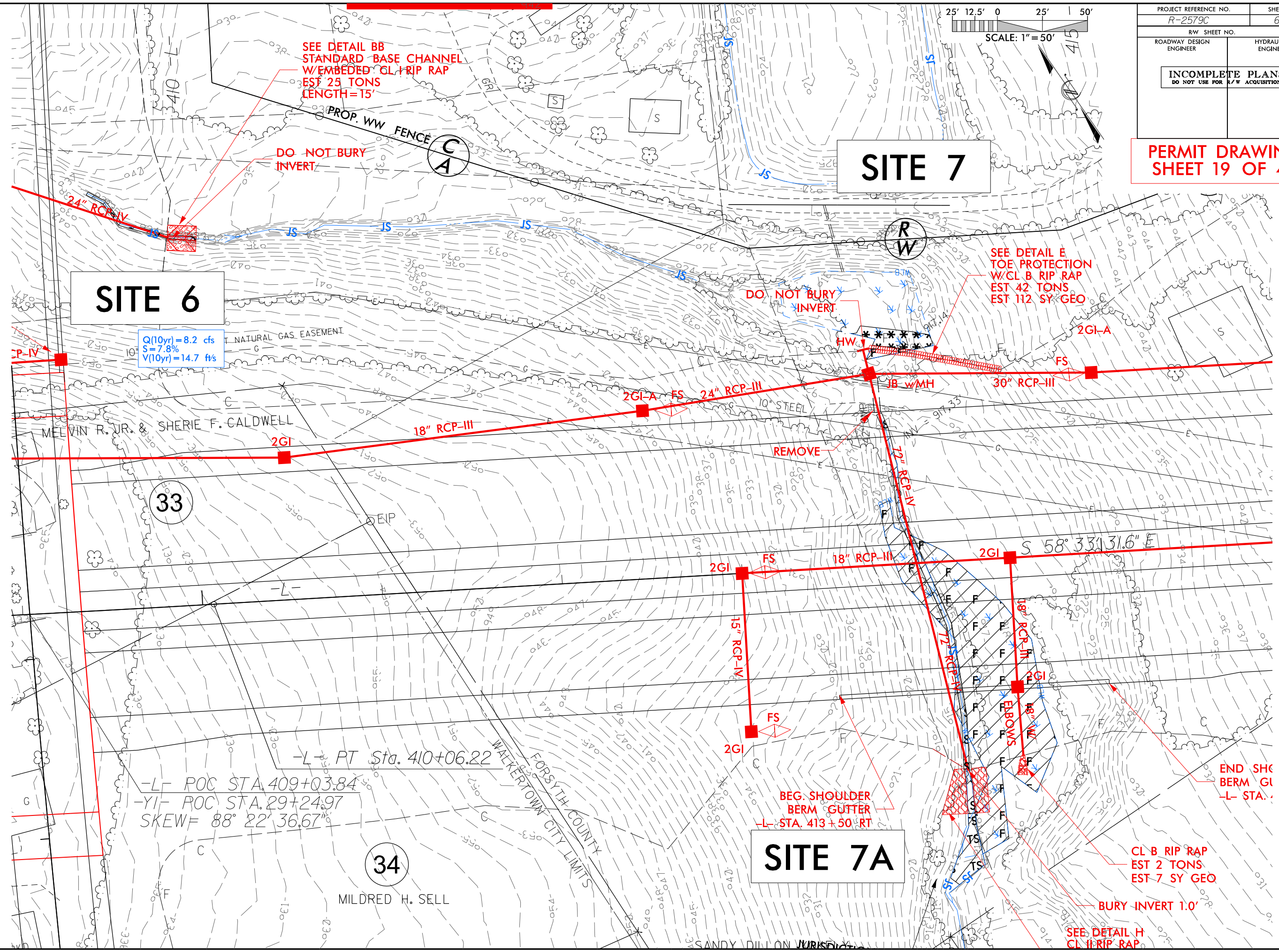

SITE 6

Q(10yr) = 8.2 cfs
S = 7.8%
V(10yr) = 14.7 ft/s

SITE 7

SITE 7A

-L- RT Sta. 410+06.22

-L- ROC STA. 409+03.84
-YI- ROC STA. 29+24.97
SKEW = 88° 22' 36.67"

34
MILDRED H. SELL

END SHO
BERM GI
-L- STA.

CL B RIP RAP
EST 2 TONS
EST 7 SY GEO

BURY INVERT 1.0'

SEE DETAIL H
CL B RIP RAP

REVISIONS

5/11/2017 Hyd_prm_wet_psh_06e.dgn

6/23/16

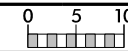

PROJ. REFERENCE NO.	SHEET NO.
U-2579C	X-58

SITE 7A

PERMIT DRAWING
SHEET 23 OF 40

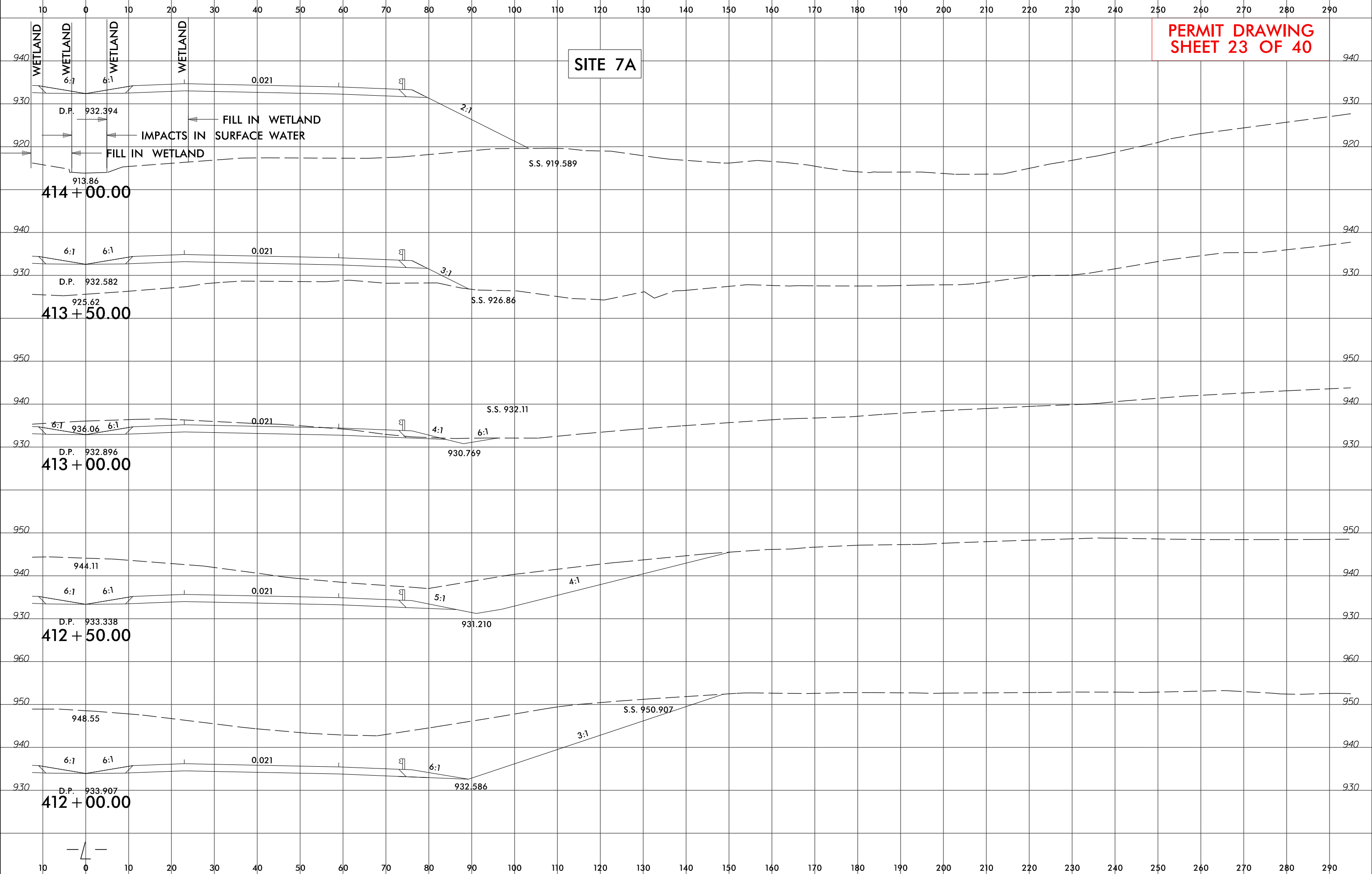

5/19/2017
U2579C_Hyd_prm_wet_psh_06.dgn
DeTam



300

200

100

0

100

200

300

413+97 -L-

PERMIT DRAWING
SHEET 25 OF 40

950

940

930

920

910

SITE 7

SITE 7A

INV IN=916.0

72" RCP
SLOPE=1.45%

INV OUT=911.5
BURY 1 FT

8/17/99

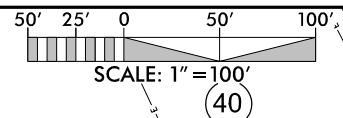

PROJECT REFERENCE NO. U-2579C	SHEET NO. 7
RW SHEET NO.	
ROADWAY DESIGN ENGINEER	HYDRAULICS ENGINEER

**PERMIT DRAWING
SHEET 26 OF 40**

S S DENOTES IMPACTS IN SURFACE WATER
TS TS DENOTES TEMPORARY IMPACTS IN SURFACE WATER

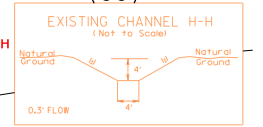
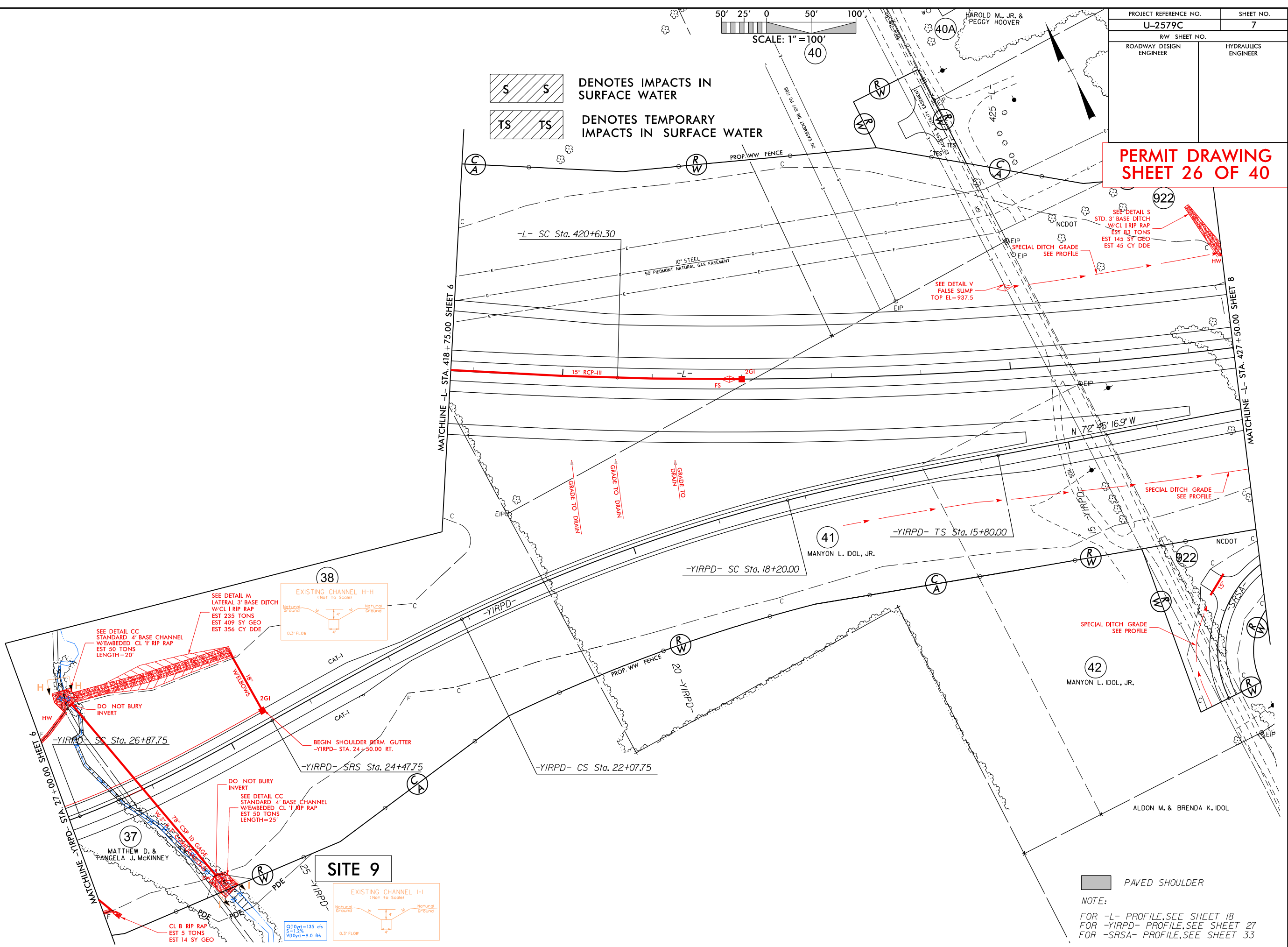

SITE 9

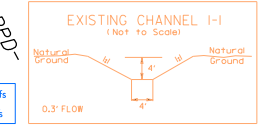

NOTE:
 FOR -L- PROFILE, SEE SHEET 18
 FOR -YIRPD- PROFILE, SEE SHEET 27
 FOR -SRSA- PROFILE, SEE SHEET 33

5/11/2017 Hyd.prm...wet_psh_07.dgn
 2579C

PROJECT REFERENCE NO. U-2579C	SHEET NO. 7
RW SHEET NO.	
ROADWAY DESIGN ENGINEER	HYDRAULICS ENGINEER

**PERMIT DRAWING
SHEET 27 OF 40**

S S DENOTES IMPACTS IN SURFACE WATER
TS TS DENOTES TEMPORARY IMPACTS IN SURFACE WATER

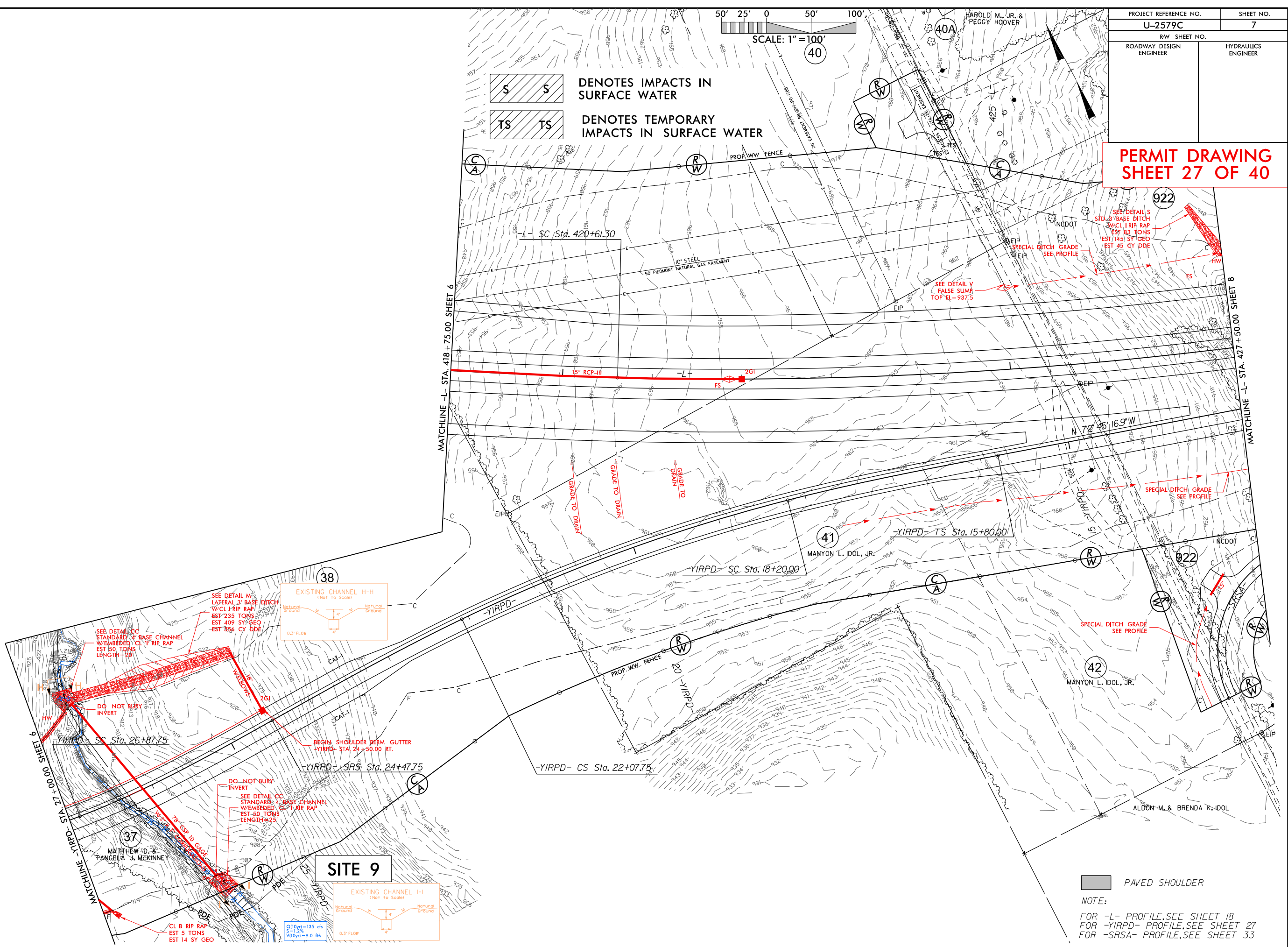
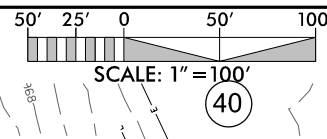

EXISTING CHANNEL H-H
(Not to Scale)

SEE DETAIL M LATERAL 3' BASE DITCH W/CL 1 RIP RAP EST 235 TONS EST 409 SY GEO EST 356 CY DDE

SEE DETAIL CC STANDARD 4' BASE CHANNEL W/EMBEDDED CL 1 RIP RAP EST 50 TONS LENGTH=20'

DO NOT BURY INVERT

EXISTING CHANNEL I-I
(Not to Scale)

SEE DETAIL CC STANDARD 4' BASE CHANNEL W/EMBEDDED CL 1 RIP RAP EST 50 TONS LENGTH=25'

DO NOT BURY INVERT

CL 8 RIP RAP EST 5 TONS EST 14 SY GEO

Q1(0y1)=135 ch
S=1.2%
V1(0y1)=9.0 ft/s

0.3' FLOOR

SITE 9

PAVED SHOULDER

NOTE:
FOR -L- PROFILE, SEE SHEET 18
FOR -YIRPD- PROFILE, SEE SHEET 27
FOR -SRS- PROFILE, SEE SHEET 33

**PERMIT DRAWING
SHEET 28 OF 40**

300

200

100

0

100

200

300

STA 26+11 -YIRPD-

960

950

940

930

920

910

900

SITE 9

INV IN=907.5

78" CSP
SLOPE=1.4%

INV OUT=904.0

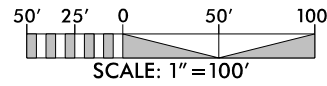

- DENOTES FILL IN WETLAND
- DENOTES MECHANIZED CLEARING
- DENOTES TEMPORARY IMPACTS IN SURFACE WATER
- DENOTES IMPACTS IN SURFACE WATER

**PERMIT DRAWING
SHEET 29 OF 40**

PROJECT REFERENCE NO. U-2579C	SHEET NO. 8
RW SHEET NO.	
ROADWAY DESIGN ENGINEER	HYDRAULICS ENGINEER
DOCUMENT NOT CONSIDERED FINAL UNLESS ALL SIGNATURES COMPLETED	

RIGHT OF WAY REVISION 5/3/17 - REVISED C/A FROM -L- STA. 436+00.00 TO STA. 440+00.00 RT. ON PARCELS 932 AND 977; ADDED RAW ON PARCELS 55, 922, 932, 977, AND 978; ADDED TCE ON PARCELS 55 AND 932; ADDED PDE ON PARCEL 55. JMB

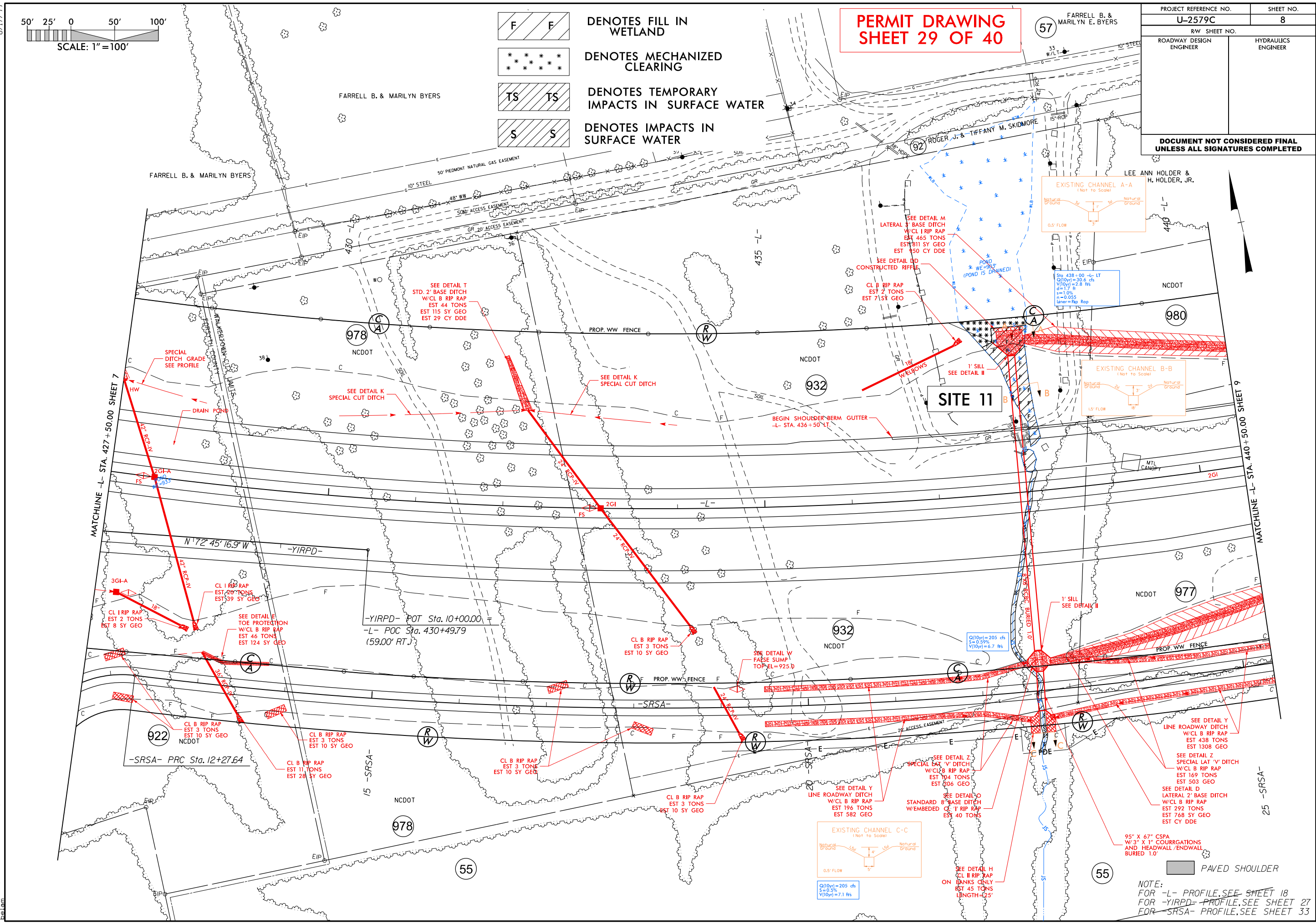

NOTE: FOR -L- PROFILE, SEE SHEET 18
FOR -YIRPD- PROFILE, SEE SHEET 27
FOR -SRSA- PROFILE, SEE SHEET 33

5/19/2017 Hyd_prm_wet_psh_08.dgn

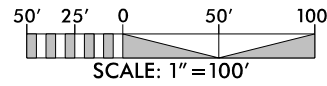

- DENOTES FILL IN WETLAND
- DENOTES MECHANIZED CLEARING
- DENOTES TEMPORARY IMPACTS IN SURFACE WATER
- DENOTES IMPACTS IN SURFACE WATER

**PERMIT DRAWING
SHEET 30 OF 40**

PROJECT REFERENCE NO. U-2579C	SHEET NO. 8
RW SHEET NO.	
ROADWAY DESIGN ENGINEER	HYDRAULICS ENGINEER
DOCUMENT NOT CONSIDERED FINAL UNLESS ALL SIGNATURES COMPLETED	

RIGHT OF WAY REVISION 5/3/17 - REVISED C/A FROM -L- STA. 436+00.00 TO STA. 440+00.00 RT. ON PARCELS 932 AND 977; ADDED RAW ON PARCELS 55, 922, 932, 977, AND 978; ADDED TCE ON PARCELS 55 AND 932; ADDED PDE ON PARCEL 55. JMB
 5/19/2017 Hyd.prm...wet.psh.08a.dgn

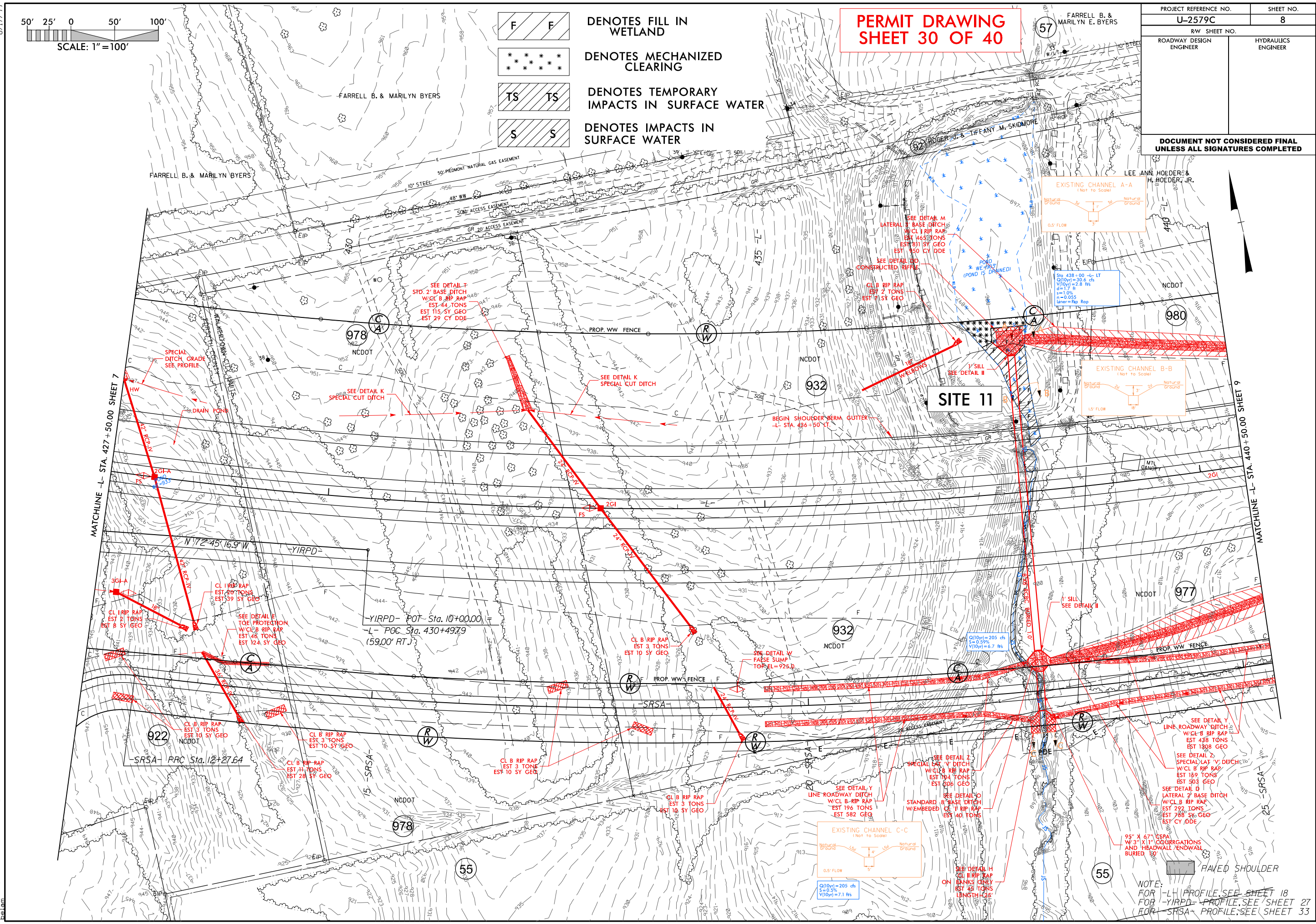

NOTE:
 FOR -LH- PROFILE, SEE SHEET 18
 FOR -YIRPD- PROFILE, SEE SHEET 27
 FOR -SRSA- PROFILE, SEE SHEET 33

6/23/16

290 280 270 260 250 240 230 220 210 200 190 180 170 160 150 140 130 120 110 100 90 80 70 60 50 40 30 20 10 0 10

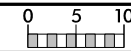

PROJ. REFERENCE NO.	SHEET NO.
U-2579C	X-149

PERMIT DRAWING
SHEET 31 OF 40

SITE 11

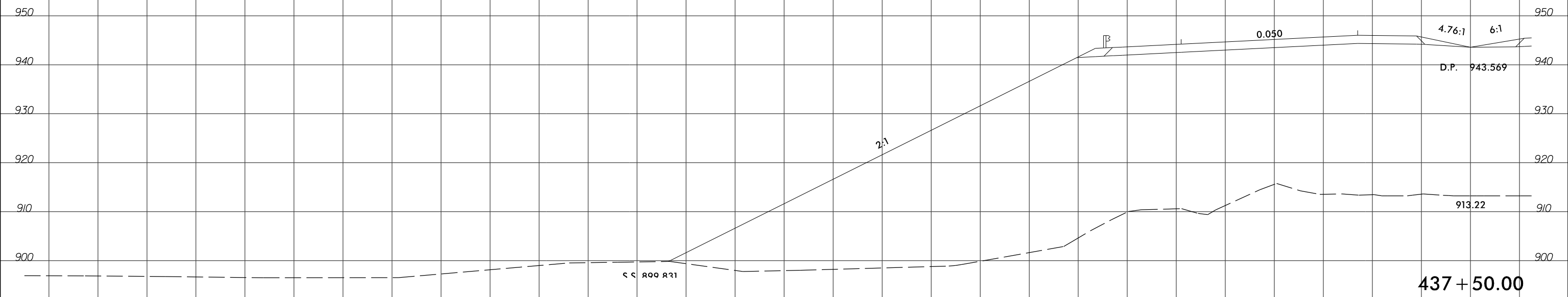
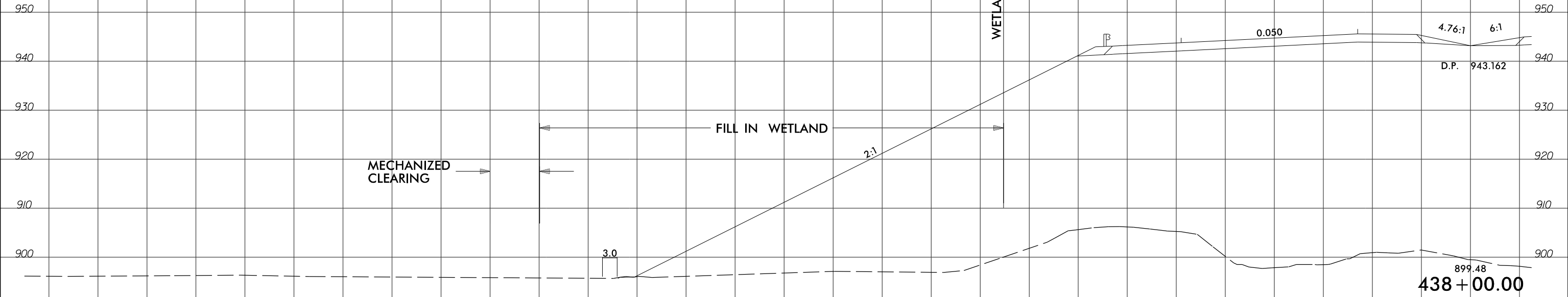

5/19/2017
U2579C_Hyd_prm_wet_psh_08b.dgn
D:\am

290 280 270 260 250 240 230 220 210 200 190 180 170 160 150 140 130 120 110 100 90 80 70 60 50 40 30 20 10 0 10

6/23/16



PROJ. REFERENCE NO.
U-2579C

SHEET NO.
8E

300 200 100 0 100 200 300

437+98 -L-

22+71.06 -SRSA-

PERMIT DRAWING
SHEET 32 OF 40

960

950

940

930

920

910

900

890

SITE 11

INV IN=894.5
BURY 1 FT

8'x8' RCBC
SLOPE=0.59%

INV OUT=892.5
BURY 1 FT

INV IN=892.2
BURY 1 FT

95'x67" CSPA
SLOPE=0.89%

INV OUT=891.8
BURY 1 FT

5/11/2017
U2579C_Hyd.prm_wet_psh_08e.dgn
Detam

8/17/99

F F DENOTES FILL IN WETLAND

*** * * * *** DENOTES MECHANIZED CLEARING

S S DENOTES IMPACTS IN SURFACE WATER

TS TS DENOTES TEMPORARY IMPACTS IN SURFACE WATER

MICHAEL WADE WESTMORELAND

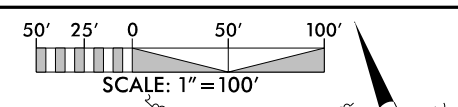

PROJECT REFERENCE NO. U-2579C	SHEET NO. 11
RW SHEET NO.	
ROADWAY DESIGN ENGINEER	HYDRAULICS ENGINEER
DOCUMENT NOT CONSIDERED FINAL UNLESS ALL SIGNATURES COMPLETED	

PERMIT DRAWING
SHEET 33 OF 40

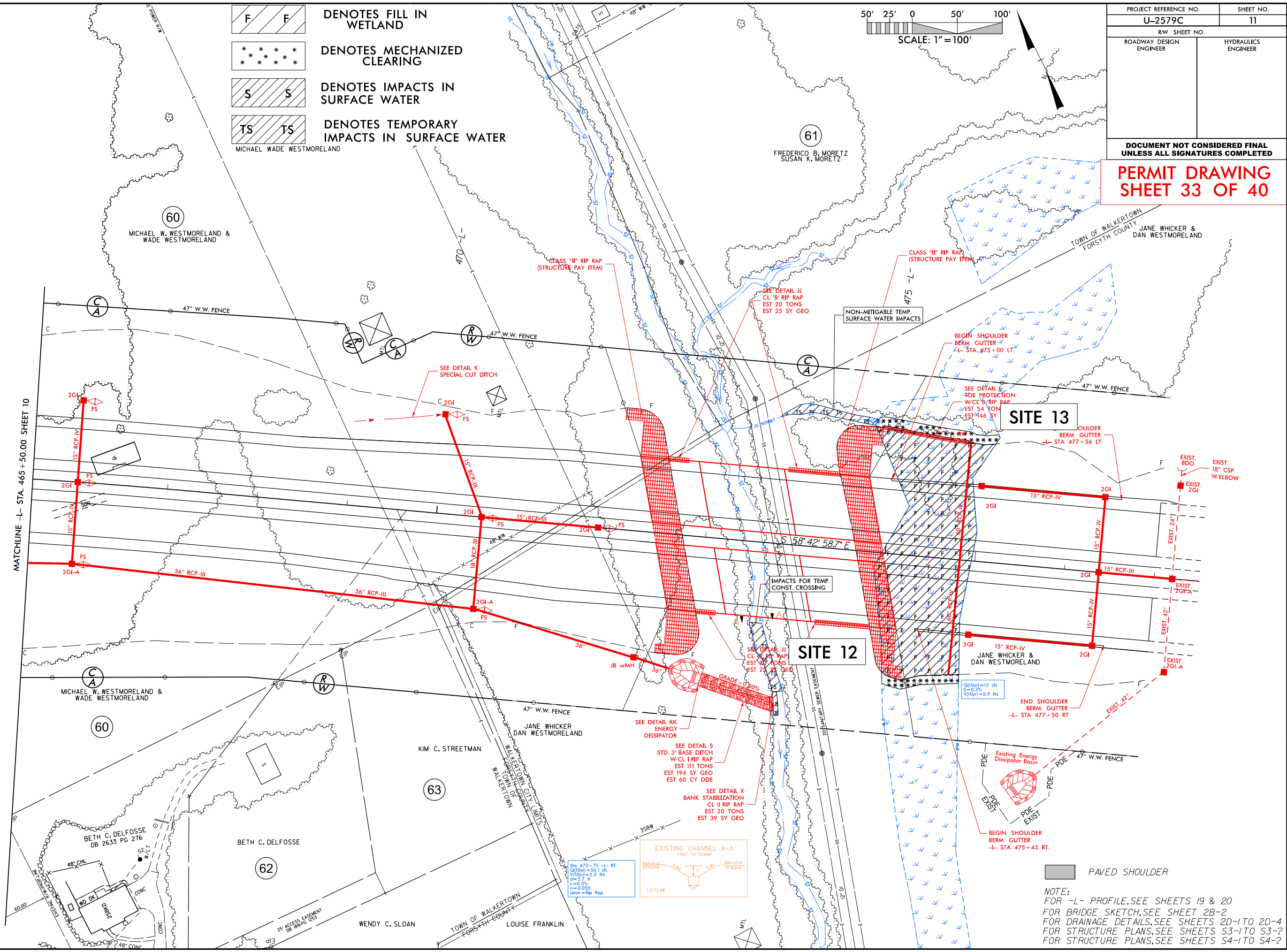





PAVED SHOULDER

NOTE:
 FOR -L- PROFILE, SEE SHEETS 19 & 20
 FOR BRIDGE SKETCH, SEE SHEET 2B-2
 FOR DRAINAGE DETAILS, SEE SHEETS 2D-1 TO 2D-4
 FOR STRUCTURE PLANS, SEE SHEETS S3-1 TO S3-2
 FOR STRUCTURE PLANS, SEE SHEETS S4-1 TO S4-2

5/21/2017 Hyd.prm...wet_psh_11.dgn
 25' ACCESS EASEMENT DB 18946 0253

8/17/99

F:\21\2017_Hyd.prm_wet.psh_11a.dgn
bclm

-  DENOTES FILL IN WETLAND
-  DENOTES MECHANIZED CLEARING
-  DENOTES IMPACTS IN SURFACE WATER
-  DENOTES TEMPORARY IMPACTS IN SURFACE WATER

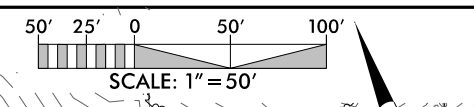

PROJECT REFERENCE NO. U-2579C	SHEET NO. 11
RW SHEET NO.	
ROADWAY DESIGN ENGINEER	HYDRAULICS ENGINEER
DOCUMENT NOT CONSIDERED FINAL UNLESS ALL SIGNATURES COMPLETED	

PERMIT DRAWING
SHEET 34 OF 40

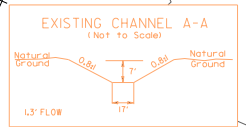
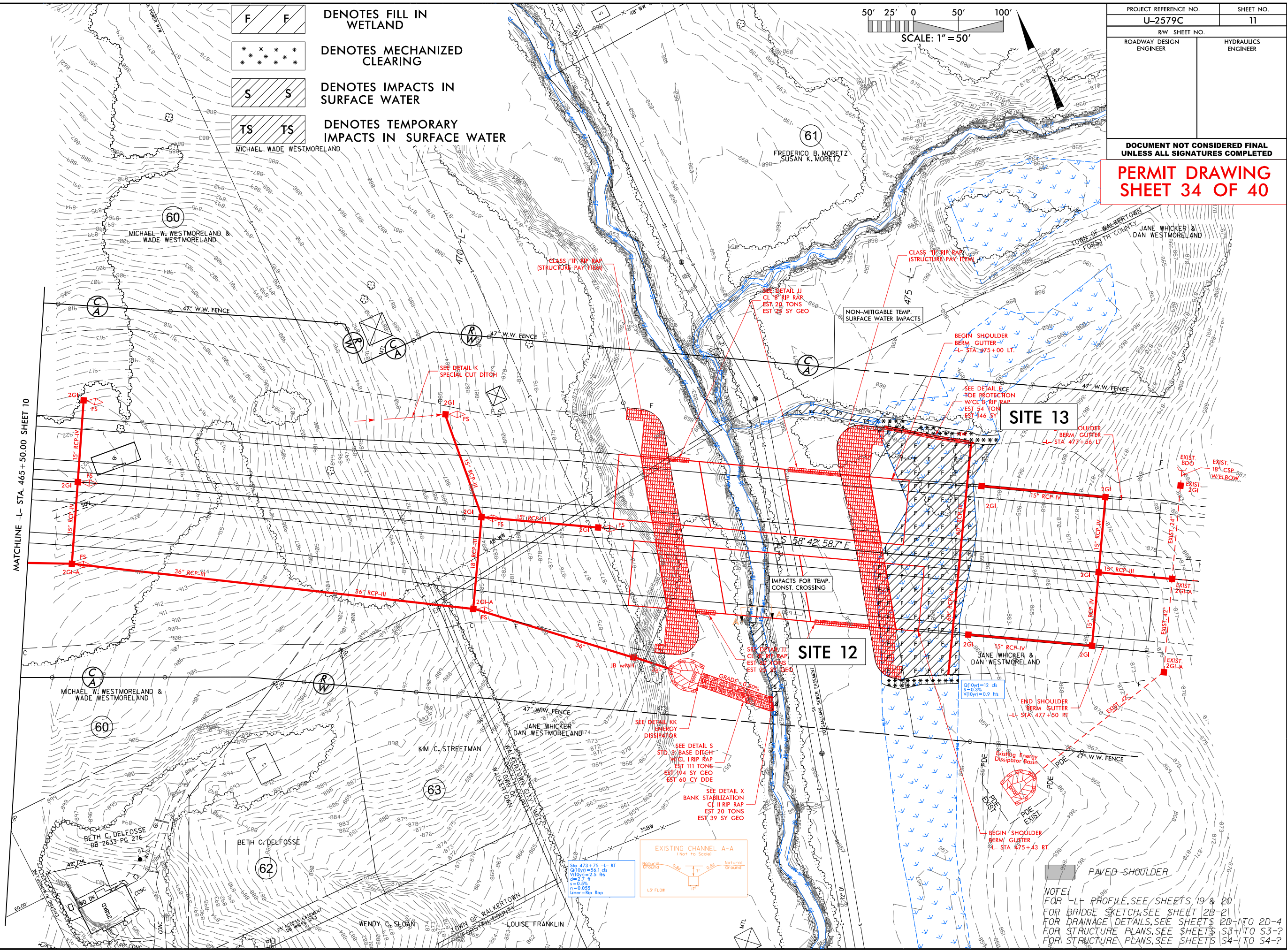

NOTE:
 FOR "L" PROFILE, SEE SHEETS 19 & 20
 FOR BRIDGE SKETCH, SEE SHEET 2B-2
 FOR DRAINAGE DETAILS, SEE SHEETS 2D-1 TO 2D-4
 FOR STRUCTURE PLANS, SEE SHEETS S3-1 TO S3-2
 FOR STRUCTURE PLANS, SEE SHEETS S4-1 TO S4-2

**PERMIT DRAWING
SHEET 35 OF 40**

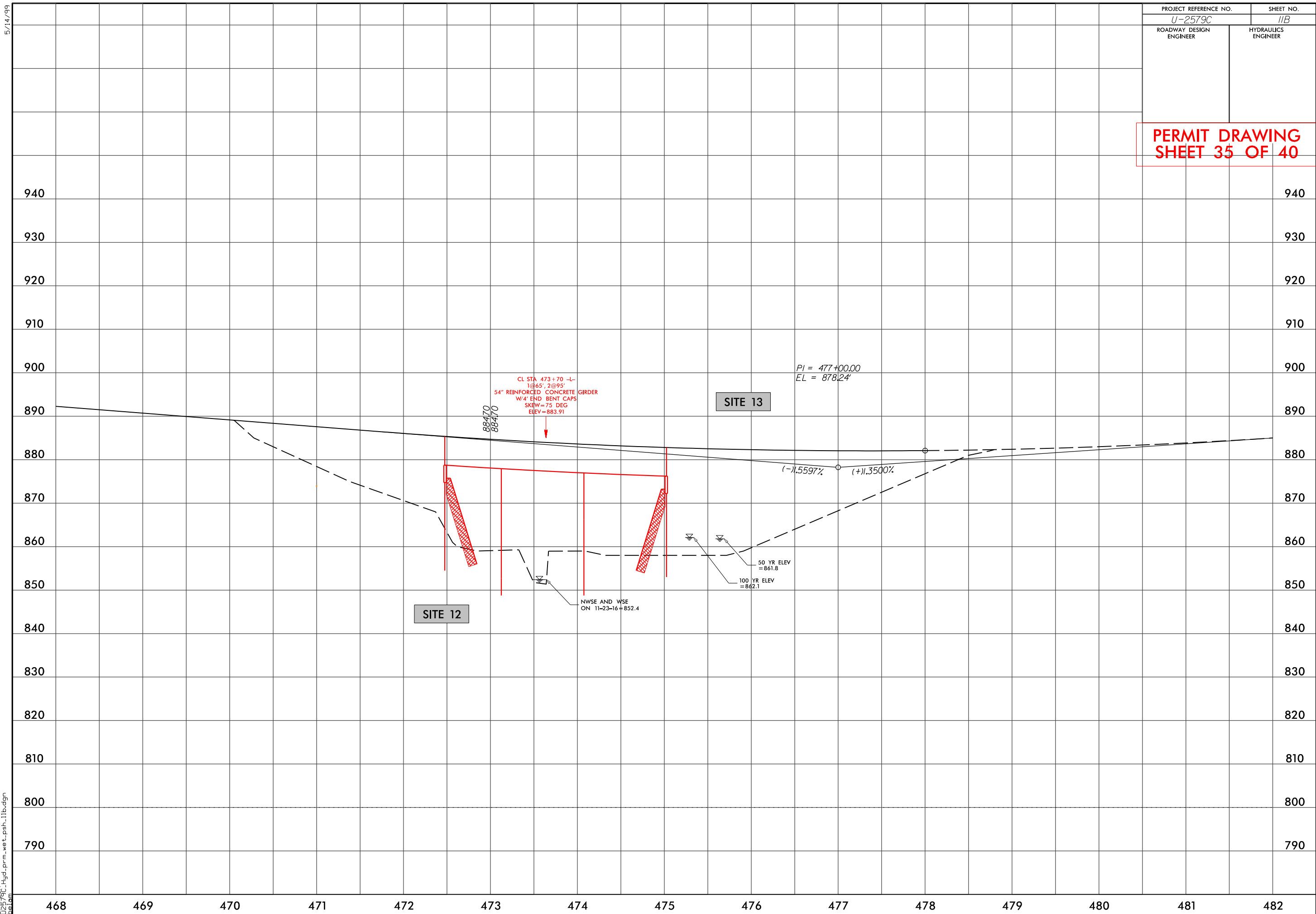

5/14/99

5/14/2017 Hyd-prm-wet-psh-11b.dgn
belam

6/23/16

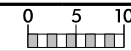

PROJ. REFERENCE NO.	SHEET NO.
U-2579C	X-96

10 0 10 20 30 40 50 60 70 80 90 100 110 120 130 140 150 160 170 180 190 200 210 220 230 240 250 260 270 280 290

**PERMIT DRAWING
SHEET 36 OF 40**

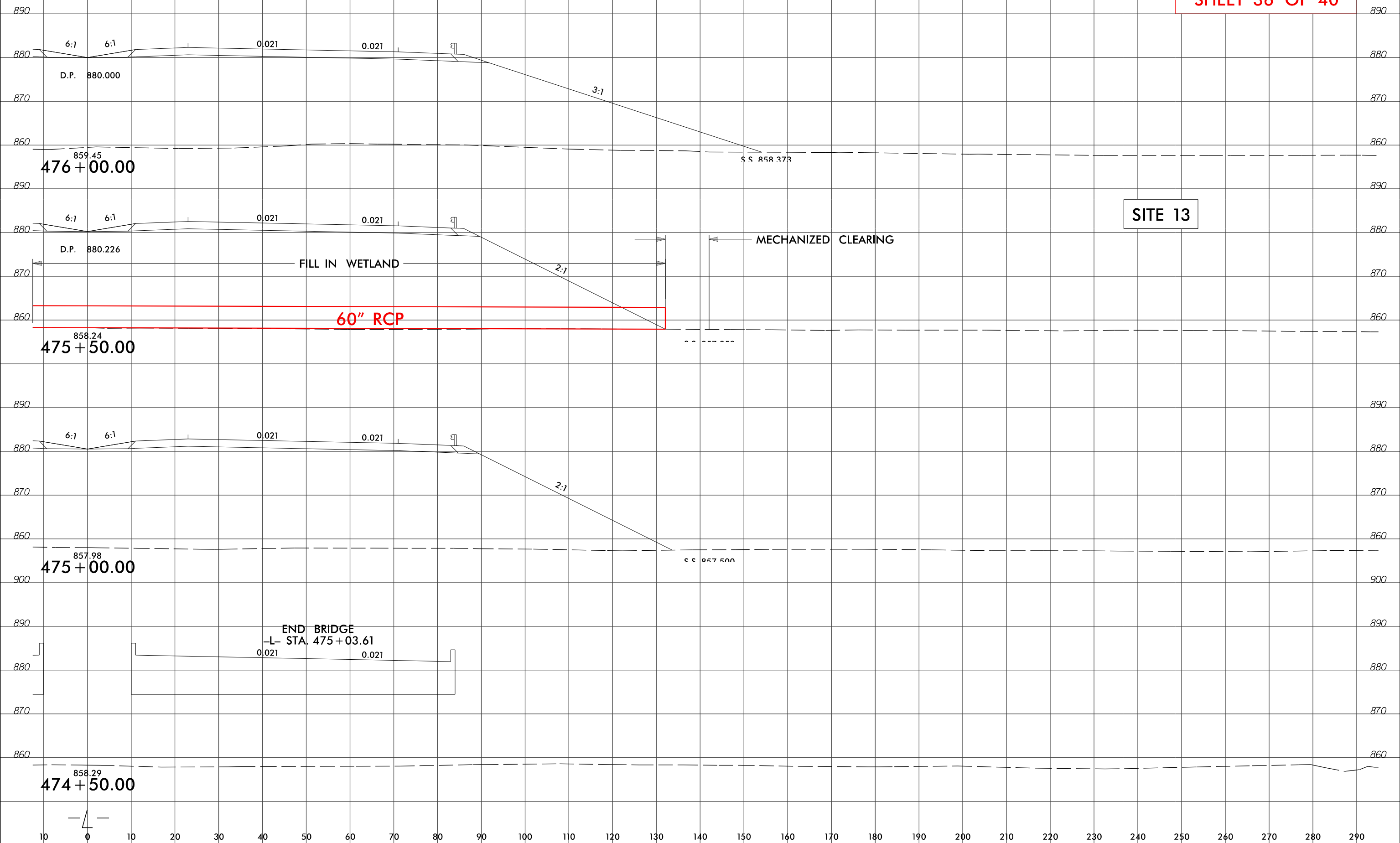

SITE 13

5/31/2017
U2579C_Hyd_prm_wet_psh_11c.dgn
dellam

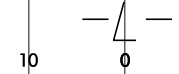

6/23/16

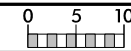

PROJ. REFERENCE NO.	SHEET NO.
U-2579C	X-172

890 290 280 270 260 250 240 230 220 210 200 190 180 170 160 150 140 130 120 110 100 90 80 70 60 50 40 30 20 10 0 10 890

**PERMIT DRAWING
SHEET 37 OF 40**

WETLAND

SITE 13

MECHANIZED CLEARING

FILL IN WETLAND

60" RCP

S.S. 859.593

858.24
475 + 50.00

S.S. 858.882

857.98
475 + 00.00

END BRIDGE
-L- STA. 474 + 91.29

858.29
474 + 50.00

859.19
474 + 00.00

290 280 270 260 250 240 230 220 210 200 190 180 170 160 150 140 130 120 110 100 90 80 70 60 50 40 30 20 10 0 10

5/19/2017
U2579C_Hyd_prm_wet_psh_11.dgn
DeTam

PROJECT REFERENCE NO. U-2579C	SHEET NO. 13
RW SHEET NO.	
ROADWAY DESIGN ENGINEER	HYDRAULICS ENGINEER

**DOCUMENT NOT CONSIDERED FINAL
UNLESS ALL SIGNATURES COMPLETED**

**PERMIT DRAWING
SHEET 38 OF 40**

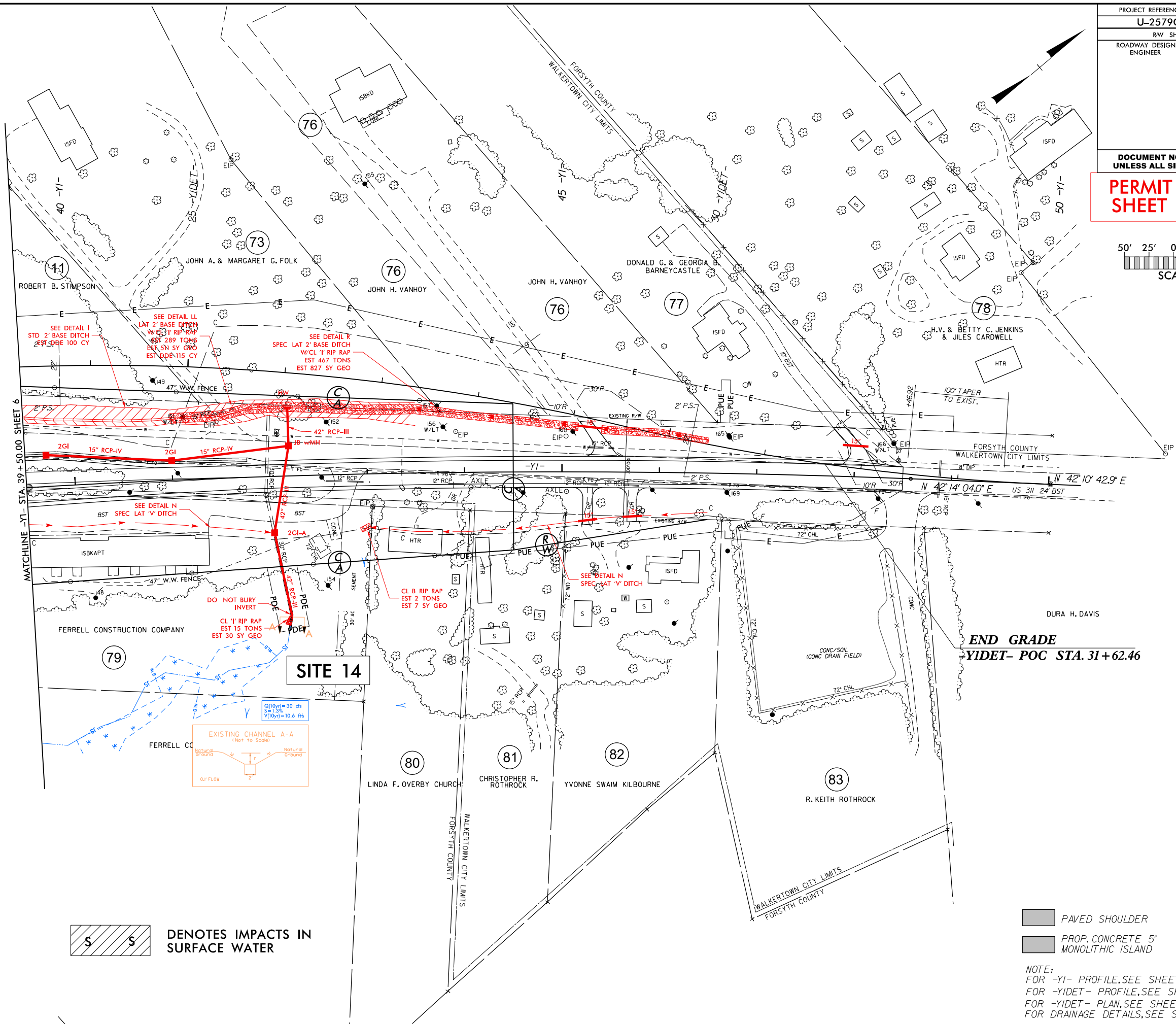
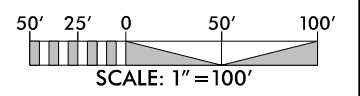

DENOTES IMPACTS IN SURFACE WATER

PAVED SHOULDER

PROP. CONCRETE 5' MONOLITHIC ISLAND

NOTE:
 FOR -YI- PROFILE, SEE SHEET 23
 FOR -YDET- PROFILE, SEE SHEET 30
 FOR -YDET- PLAN, SEE SHEETS 2B-5 & 2B-6
 FOR DRAINAGE DETAILS, SEE SHEETS 2D-1 TO 2D-4

PROJECT REFERENCE NO.	SHEET NO.
U-2579C	13
RW SHEET NO.	
ROADWAY DESIGN ENGINEER	HYDRAULICS ENGINEER

**DOCUMENT NOT CONSIDERED FINAL
UNLESS ALL SIGNATURES COMPLETED**

**PERMIT DRAWING
SHEET 39 OF 40**

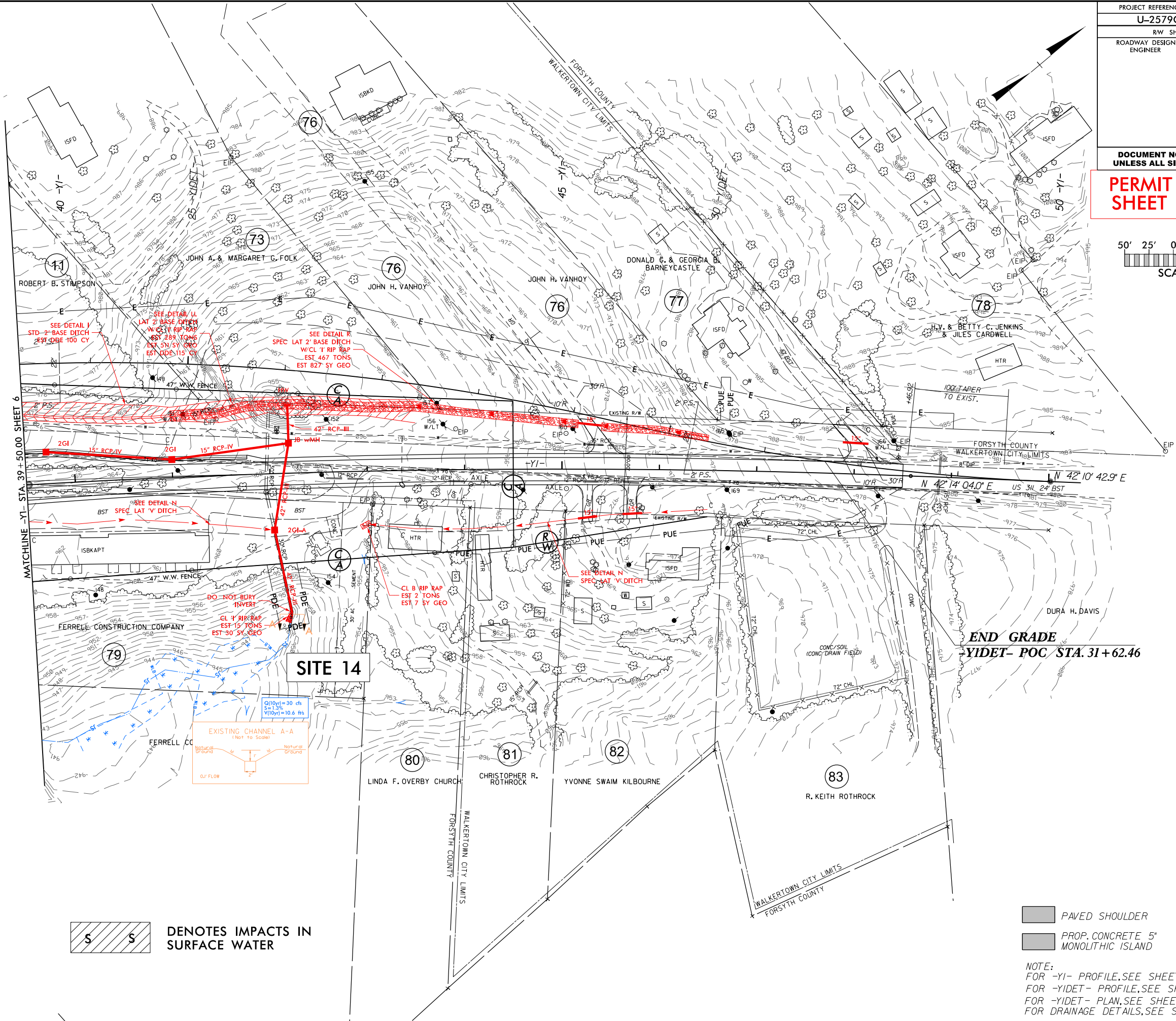
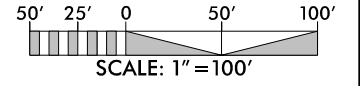

DENOTES IMPACTS IN SURFACE WATER

- PAVED SHOULDER
- PROP. CONCRETE 5' MONOLITHIC ISLAND

NOTE:
 FOR -YI- PROFILE, SEE SHEET 23
 FOR -YIDET- PROFILE, SEE SHEET 30
 FOR -YIDET- PLAN, SEE SHEETS 2B-5 & 2B-6
 FOR DRAINAGE DETAILS, SEE SHEETS 2D-1 TO 2D-4

09/08/15

See Sheet 1A For Index of Sheets
See Sheet 1B For Conventional Symbols

STATE OF NORTH CAROLINA DIVISION OF HIGHWAYS

STATE	STATE PROJECT REFERENCE NO.	SHEET NO.	TOTAL SHEETS
N.C.	U-2579C	1	
STATE PROJ. NO.	F.A. PROJ. NO.	DESCRIPTION	
34839.1.9	N/A	PE	
34839.2.6	N/A	R/W	
34839.2.GV18	N/A	R/W	
34839.2.16	N/A	UTIL	
34839.3.GV6	NHP-0918(062)	CONSTR.	

FORSYTH COUNTY

LOCATION: WINSTON - SALEM NORTHERN BELTWAY (EASTERN SECTION)
FROM US 311 TO US 158 (FUTURE I-74)

TYPE OF WORK: WIDENING, GRADING, PAVING, DRAINAGE, SIGNING, SIGNALS, ITS, CULVERTS AND STRUCTURES.

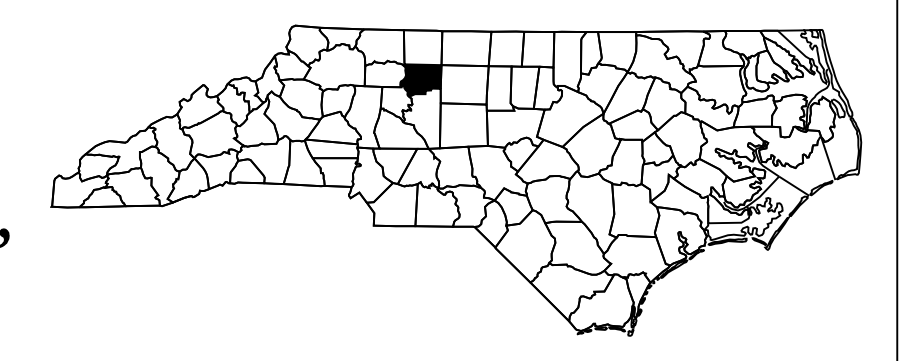

TIP PROJECT: U-2579C

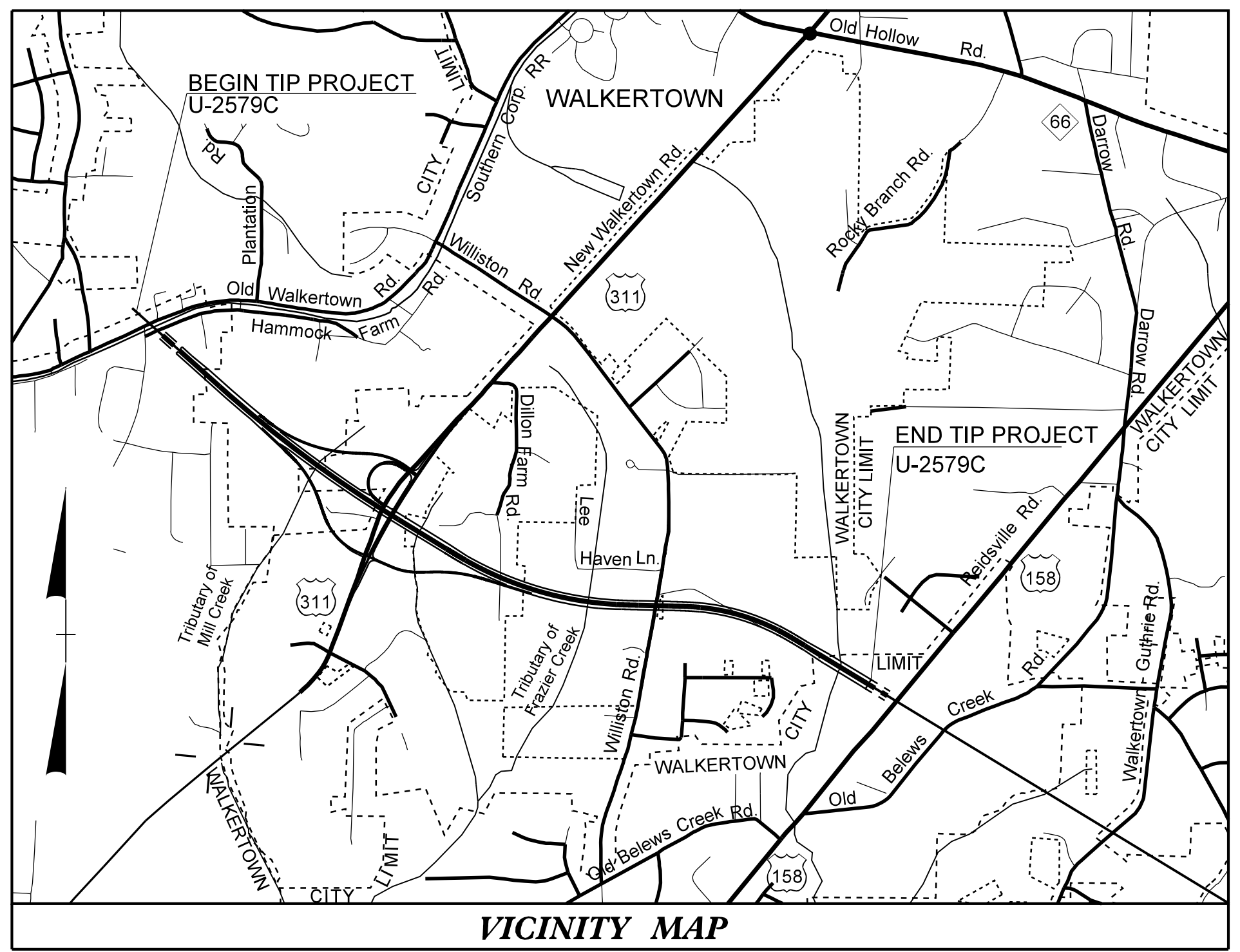

PLFI PLANS

END BRIDGE
-L- POT STA. 474+46.29 (LT)
-L- POT STA. 474+58.61 (RT)

BEGIN BRIDGE
-L- POT STA. 472+36.29 (LT)
-L- POT STA. 472+48.61 (RT)

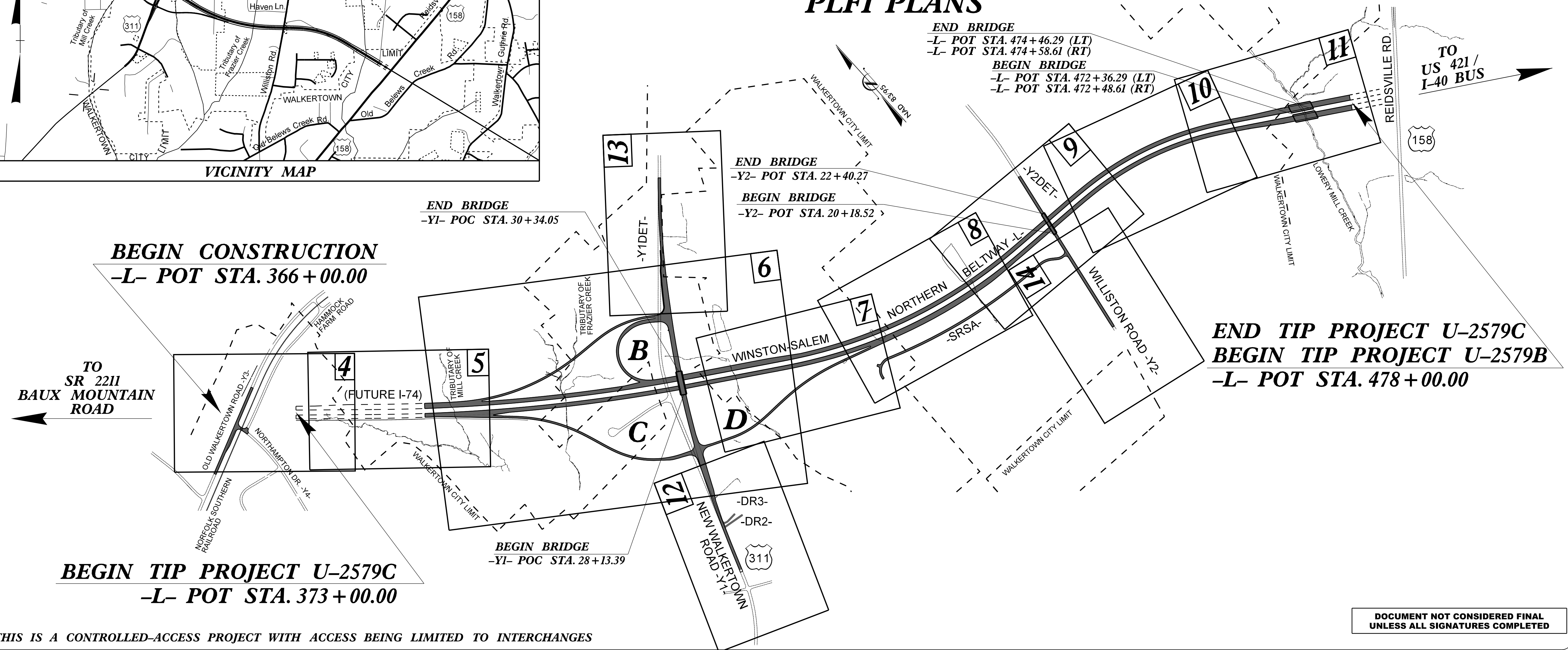

CONTRACT:

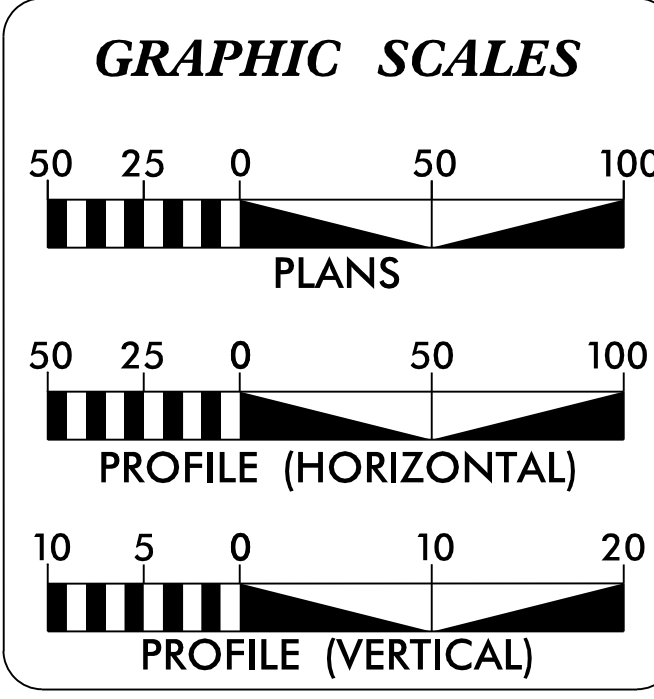

DESIGN DATA

ADT 2017 =	65,592
ADT 2037 =	93,112
DHV =	10 %
D =	60 %
T =	18 % *
V =	70 MPH
* TTST 12 %	DUAL 6 %

PROJECT LENGTH

LENGTH OF ROADWAY PROJECT U-2579C	=	1.989 Miles
LENGTH OF STRUCTURE PROJECT U-2579C	=	0.040 Mile
TOTAL LENGTH OF TIP PROJECT U-2579C	=	1.949 Miles

PLANS PREPARED BY:
RS&H & SUNGATE DESIGN GROUP, P.A.
8601 SIX FORKS RD, SUITE 260
RALEIGH, NC 27615
919-926-4100

FOR THE NORTH CAROLINA DEPARTMENT OF TRANSPORTATION
2012 STANDARD SPECIFICATIONS

RIGHT OF WAY DATE:
OCTOBER 28, 2015

LETTING DATE:
OCTOBER 17, 2017

JASON TALLEY, PE
PROJECT ENGINEER

JARED BOND, PE
PROJECT DESIGN ENGINEER

TATIA L. WHITE, PE, PLS
NCDOT CONTACT

HYDRAULICS ENGINEER

SIGNATURE: _____

ROADWAY DESIGN ENGINEER

SIGNATURE: _____

**DIVISION OF HIGHWAYS
STATE OF NORTH CAROLINA**

13-MAR-2017 18:40
R:\Roadway\Proj\U2579C.rdy_tsh.dgn
\$\$\$\$\$SERNAME\$\$\$\$\$

THIS IS A CONTROLLED-ACCESS PROJECT WITH ACCESS BEING LIMITED TO INTERCHANGES

DOCUMENT NOT CONSIDERED FINAL
UNLESS ALL SIGNATURES COMPLETED

STATE OF NORTH CAROLINA, DIVISION OF HIGHWAYS

CONVENTIONAL PLAN SHEET SYMBOLS

Note: Not to Scale *S.U.E. = *Subsurface Utility Engineering*

04/06/15

BOUNDARIES AND PROPERTY:

State Line	-----
County Line	-----
Township Line	-----
City Line	-----
Reservation Line	-----
Property Line	-----
Existing Iron Pin	○ EIP
Property Corner	-----
Property Monument	□ ECM
Parcel/Sequence Number	①23
Existing Fence Line	-x-x-x-
Proposed Woven Wire Fence	○
Proposed Chain Link Fence	□
Proposed Barbed Wire Fence	◇
Existing Wetland Boundary	-WLB-
Proposed Wetland Boundary	-WLB-
Existing Endangered Animal Boundary	-EAB-
Existing Endangered Plant Boundary	-EPB-
Existing Historic Property Boundary	-HPB-
Known Contamination Area: Soil	-----
Potential Contamination Area: Soil	-----
Known Contamination Area: Water	-----
Potential Contamination Area: Water	-----
Contaminated Site: Known or Potential	☠ ?

BUILDINGS AND OTHER CULTURE:

Gas Pump Vent or U/G Tank Cap	○
Sign	○ S
Well	○ W
Small Mine	✕
Foundation	□
Area Outline	□
Cemetery	□
Building	□
School	□
Church	□
Dam	□

HYDROLOGY:

Stream or Body of Water	-----
Hydro, Pool or Reservoir	-----
Jurisdictional Stream	-JS-
Buffer Zone 1	-BZ 1-
Buffer Zone 2	-BZ 2-
Flow Arrow	←
Disappearing Stream	→
Spring	○
Wetland	-----
Proposed Lateral, Tail, Head Ditch	-----
False Sump	-----

RAILROADS:

Standard Gauge	-----
RR Signal Milepost	○ MILEPOST 35
Switch	□ SWITCH
RR Abandoned	-----
RR Dismantled	-----

RIGHT OF WAY:

Baseline Control Point	◆
Existing Right of Way Marker	△
Existing Right of Way Line	-----
Proposed Right of Way Line	-----
Proposed Right of Way Line with Iron Pin and Cap Marker	-----
Proposed Right of Way Line with Concrete or Granite RW Marker	-----
Proposed Control of Access Line with Concrete C/A Marker	-----
Existing Control of Access	-----
Proposed Control of Access	-----
Existing Easement Line	-----
Proposed Temporary Construction Easement	-----
Proposed Temporary Drainage Easement	-----
Proposed Permanent Drainage Easement	-----
Proposed Permanent Drainage / Utility Easement	-----
Proposed Permanent Utility Easement	-----
Proposed Temporary Utility Easement	-----
Proposed Aerial Utility Easement	-----
Proposed Permanent Easement with Iron Pin and Cap Marker	-----

ROADS AND RELATED FEATURES:

Existing Edge of Pavement	-----
Existing Curb	-----
Proposed Slope Stakes Cut	-C-
Proposed Slope Stakes Fill	-F-
Proposed Curb Ramp	-----
Existing Metal Guardrail	-----
Proposed Guardrail	-----
Existing Cable Guiderail	-----
Proposed Cable Guiderail	-----
Equality Symbol	○
Pavement Removal	-----

VEGETATION:

Single Tree	○
Single Shrub	○
Hedge	-----
Woods Line	-----

Orchard	-----
Vineyard	-----

EXISTING STRUCTURES:

MAJOR:	
Bridge, Tunnel or Box Culvert	-----
Bridge Wing Wall, Head Wall and End Wall	-----
MINOR:	
Head and End Wall	-----
Pipe Culvert	-----
Footbridge	-----
Drainage Box: Catch Basin, DI or JB	-----
Paved Ditch Gutter	-----
Storm Sewer Manhole	-----
Storm Sewer	-----

UTILITIES:

POWER:	
Existing Power Pole	●
Proposed Power Pole	○
Existing Joint Use Pole	●
Proposed Joint Use Pole	○
Power Manhole	○
Power Line Tower	□
Power Transformer	□
U/G Power Cable Hand Hole	-----
H-Frame Pole	●
U/G Power Line LOS B (S.U.E.*)	-----
U/G Power Line LOS C (S.U.E.*)	-----
U/G Power Line LOS D (S.U.E.*)	-----

TELEPHONE:

Existing Telephone Pole	●
Proposed Telephone Pole	○
Telephone Manhole	○
Telephone Pedestal	□
Telephone Cell Tower	□
U/G Telephone Cable Hand Hole	-----
U/G Telephone Cable LOS B (S.U.E.*)	-----
U/G Telephone Cable LOS C (S.U.E.*)	-----
U/G Telephone Cable LOS D (S.U.E.*)	-----
U/G Telephone Conduit LOS B (S.U.E.*)	-----
U/G Telephone Conduit LOS C (S.U.E.*)	-----
U/G Telephone Conduit LOS D (S.U.E.*)	-----
U/G Fiber Optics Cable LOS B (S.U.E.*)	-----
U/G Fiber Optics Cable LOS C (S.U.E.*)	-----
U/G Fiber Optics Cable LOS D (S.U.E.*)	-----

WATER:

Water Manhole	○
Water Meter	○
Water Valve	⊗
Water Hydrant	○
U/G Water Line LOS B (S.U.E.*)	-----
U/G Water Line LOS C (S.U.E.*)	-----
U/G Water Line LOS D (S.U.E.*)	-----
Above Ground Water Line	-----

TV:

TV Pedestal	□
TV Tower	⊗
U/G TV Cable Hand Hole	-----
U/G TV Cable LOS B (S.U.E.*)	-----
U/G TV Cable LOS C (S.U.E.*)	-----
U/G TV Cable LOS D (S.U.E.*)	-----
U/G Fiber Optic Cable LOS B (S.U.E.*)	-----
U/G Fiber Optic Cable LOS C (S.U.E.*)	-----
U/G Fiber Optic Cable LOS D (S.U.E.*)	-----

GAS:

Gas Valve	◇
Gas Meter	◇
U/G Gas Line LOS B (S.U.E.*)	-----
U/G Gas Line LOS C (S.U.E.*)	-----
U/G Gas Line LOS D (S.U.E.*)	-----
Above Ground Gas Line	-----

SANITARY SEWER:

Sanitary Sewer Manhole	⊕
Sanitary Sewer Cleanout	⊕
U/G Sanitary Sewer Line	-----
Above Ground Sanitary Sewer	-----
SS Forced Main Line LOS B (S.U.E.*)	-----
SS Forced Main Line LOS C (S.U.E.*)	-----
SS Forced Main Line LOS D (S.U.E.*)	-----

MISCELLANEOUS:

Utility Pole	●
Utility Pole with Base	□
Utility Located Object	○
Utility Traffic Signal Box	□
Utility Unknown U/G Line LOS B (S.U.E.*)	-----
U/G Tank; Water, Gas, Oil	-----
Underground Storage Tank, Approx. Loc.	-----
A/G Tank; Water, Gas, Oil	-----
Geoenvironmental Boring	○
U/G Test Hole LOS A (S.U.E.*)	-----
Abandoned According to Utility Records	-----
End of Information	-----

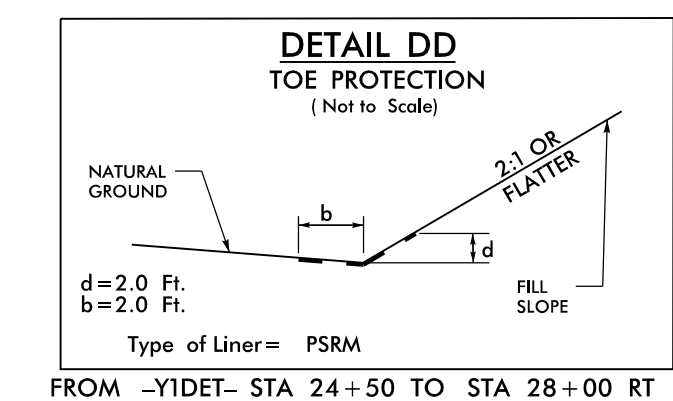
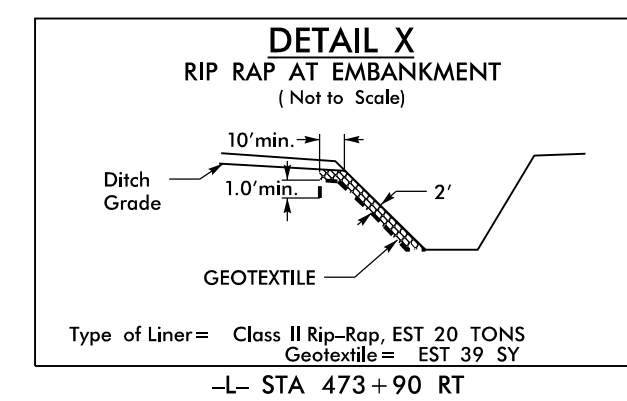
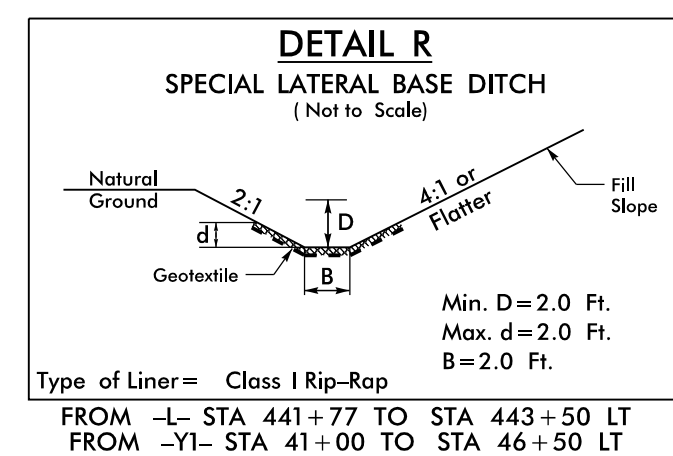
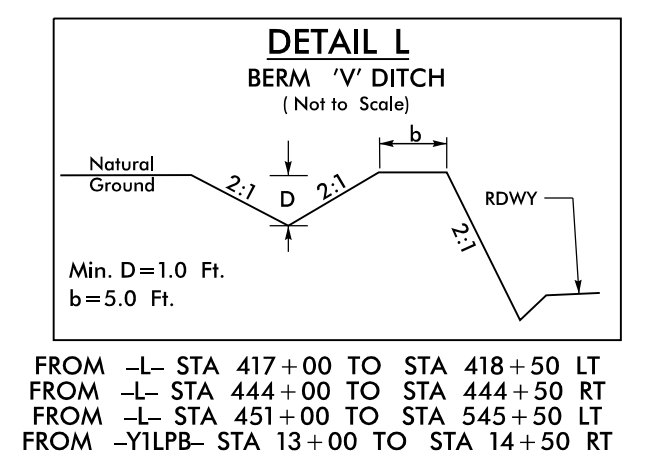
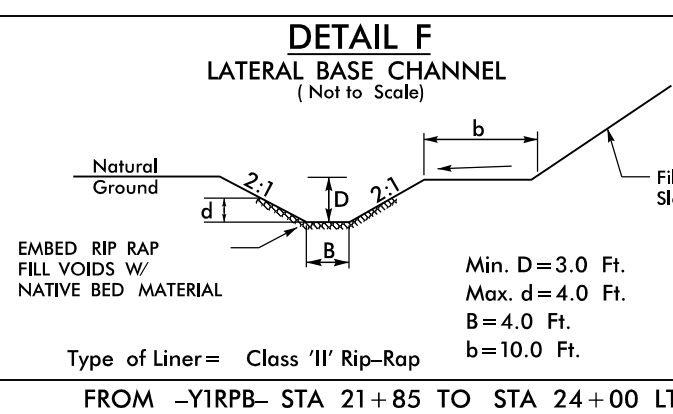
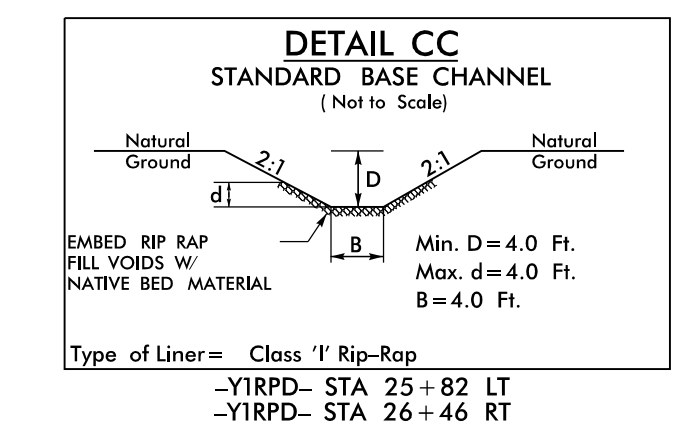
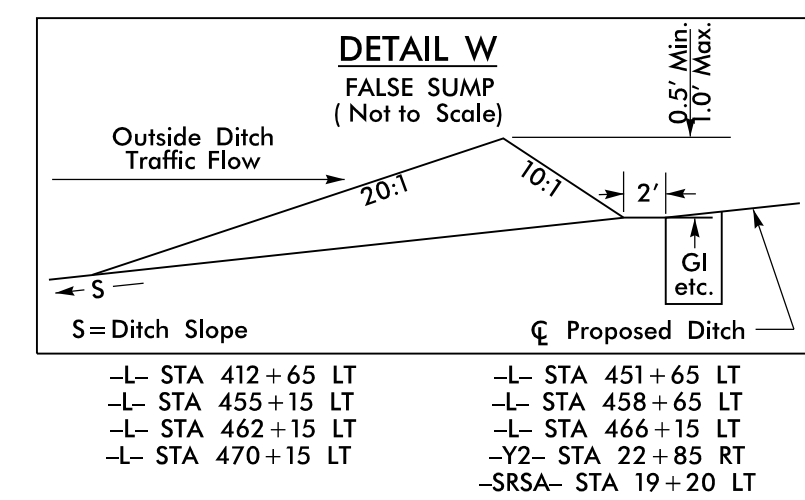
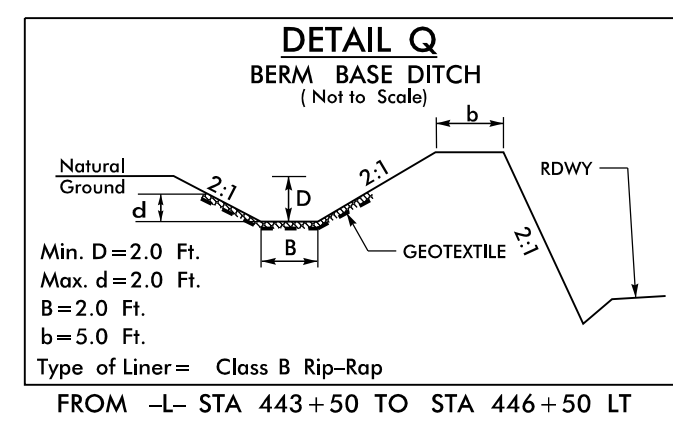
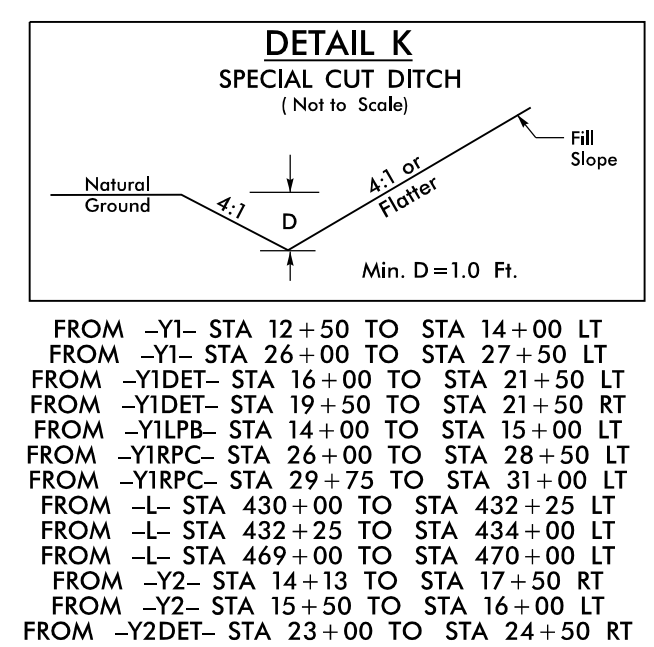
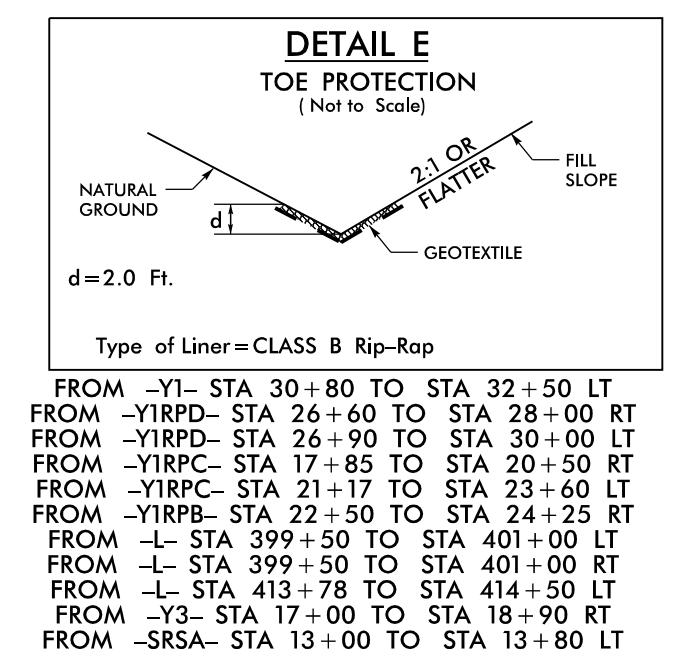
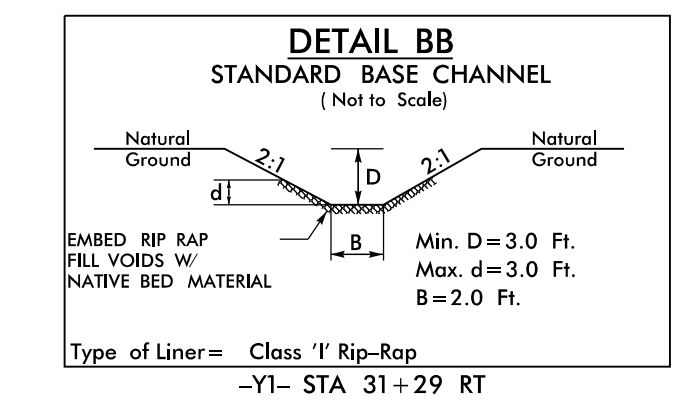
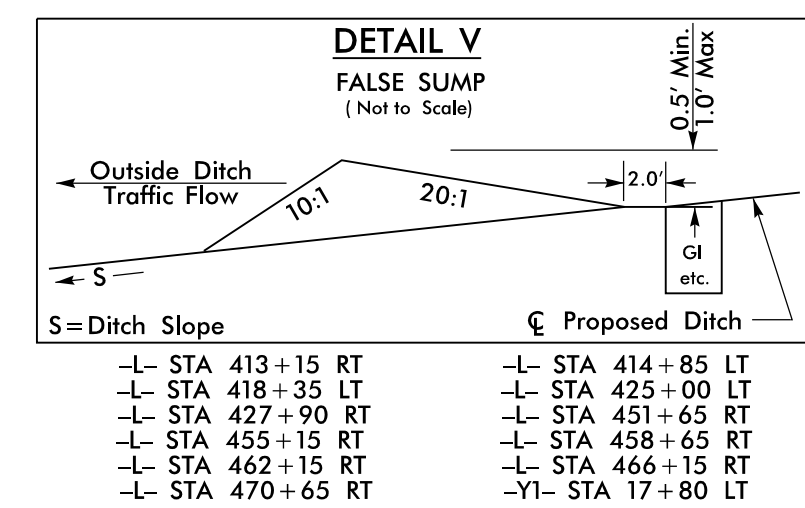
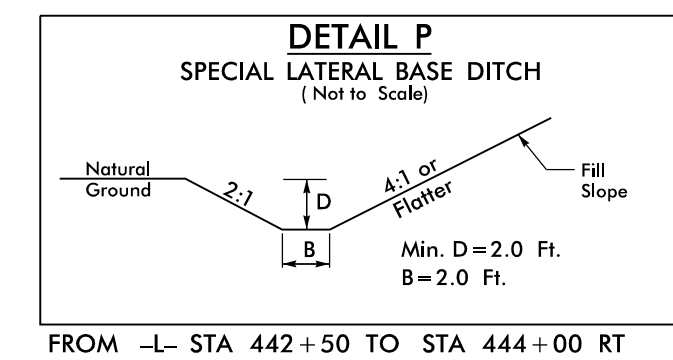
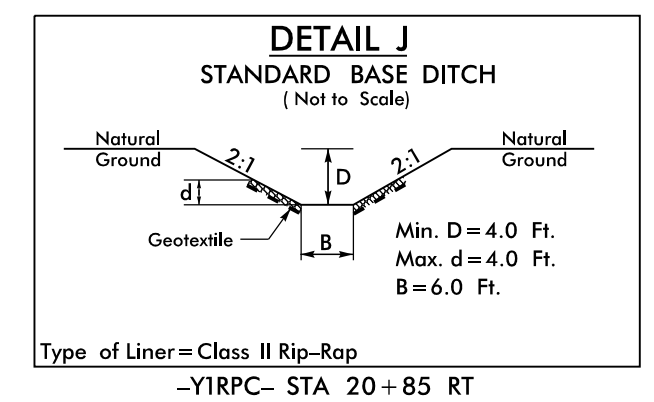
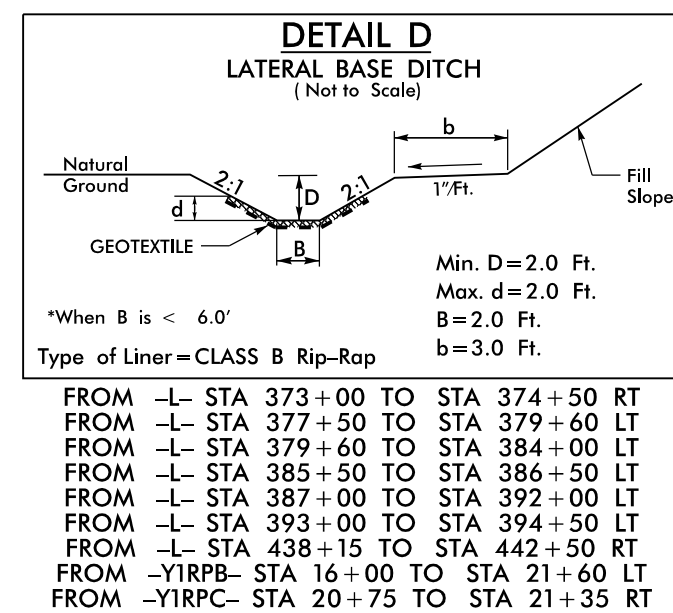
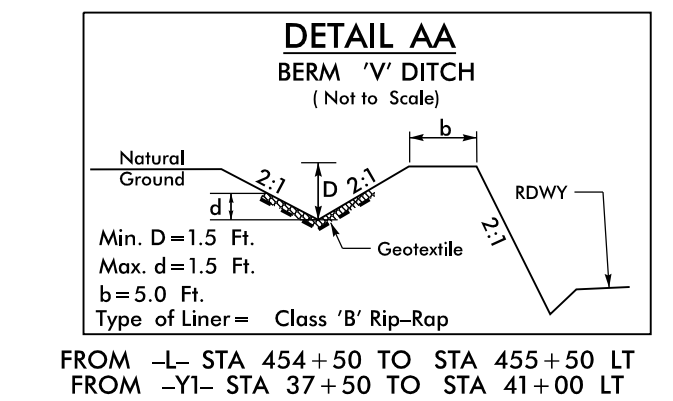
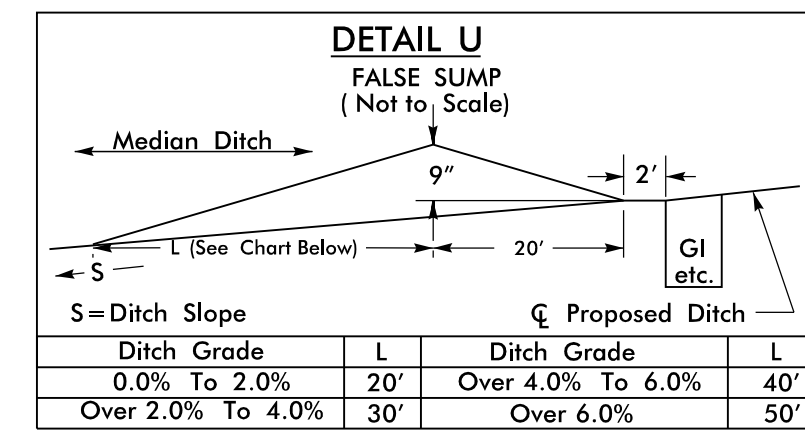
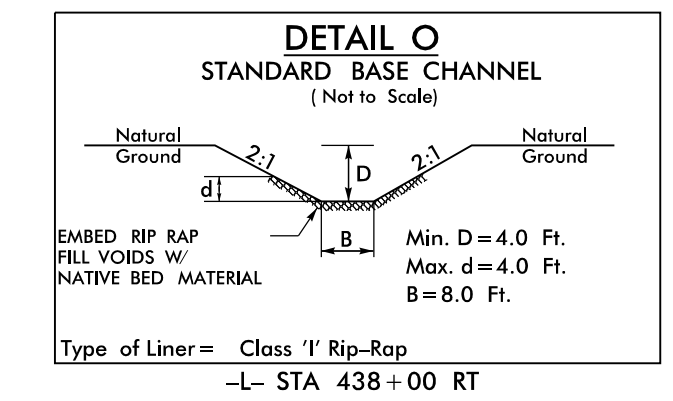
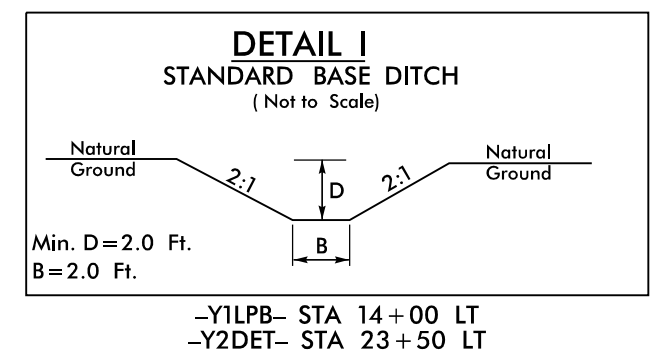
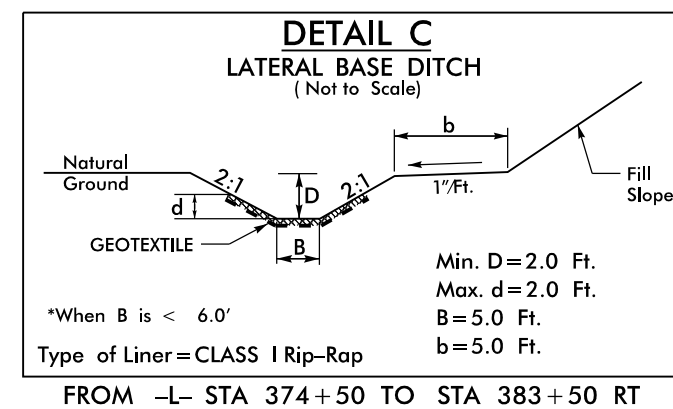
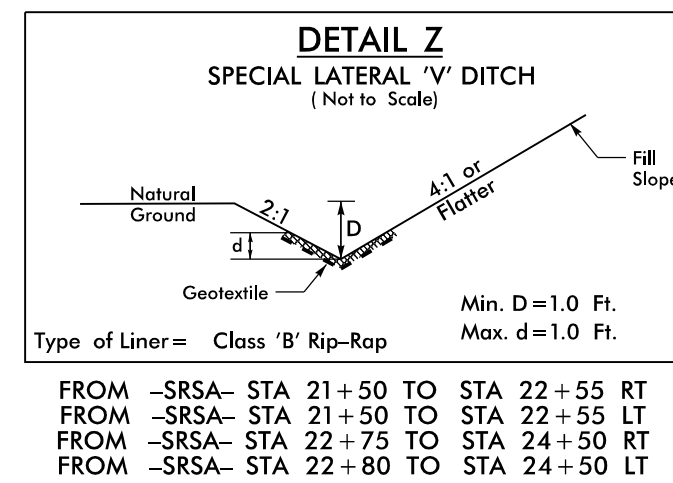
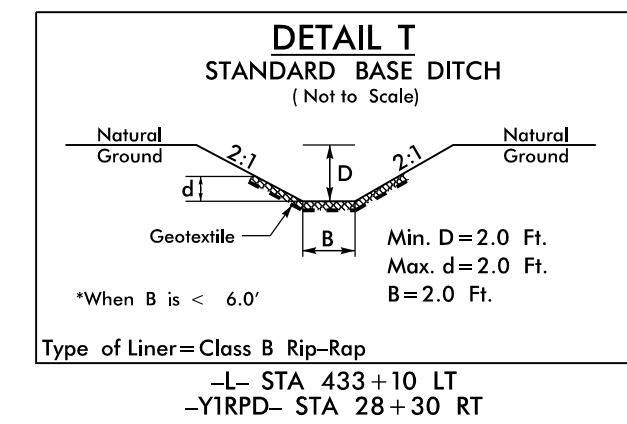
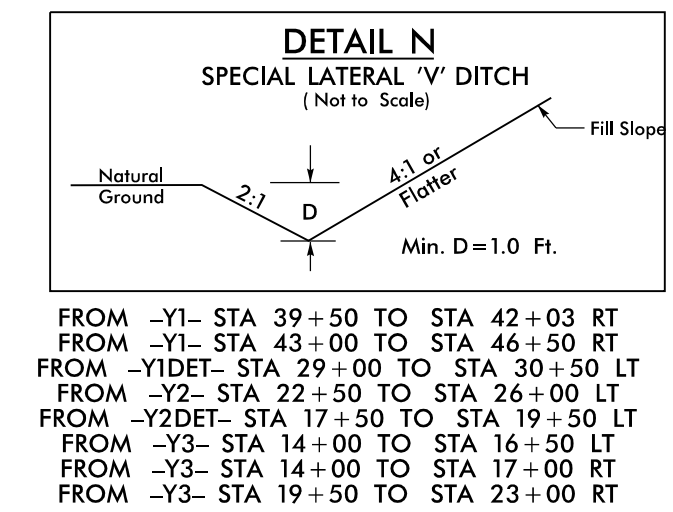
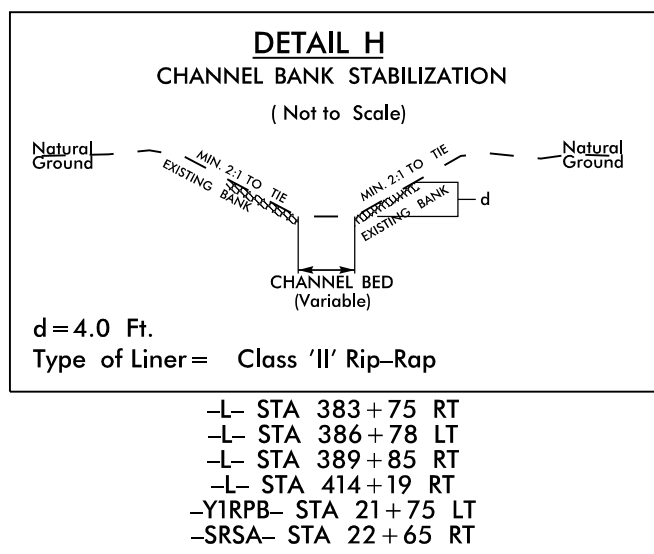
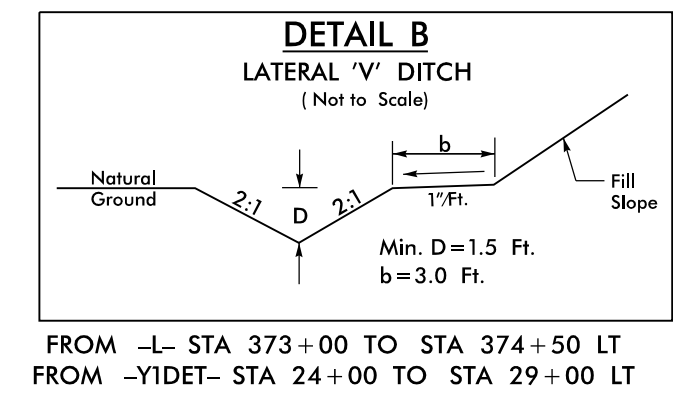
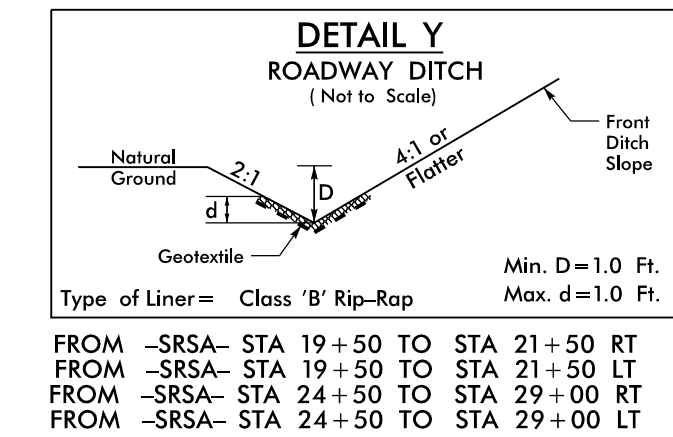
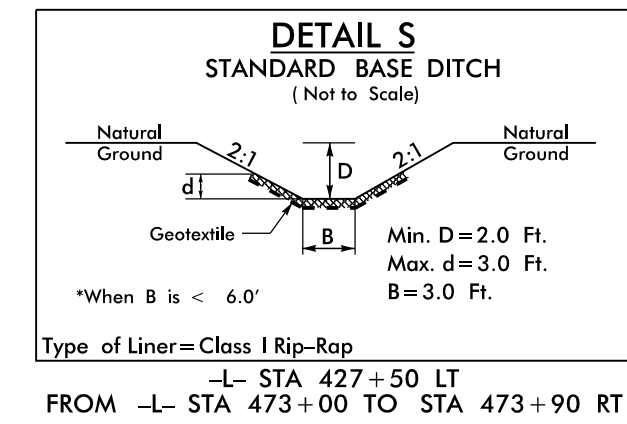
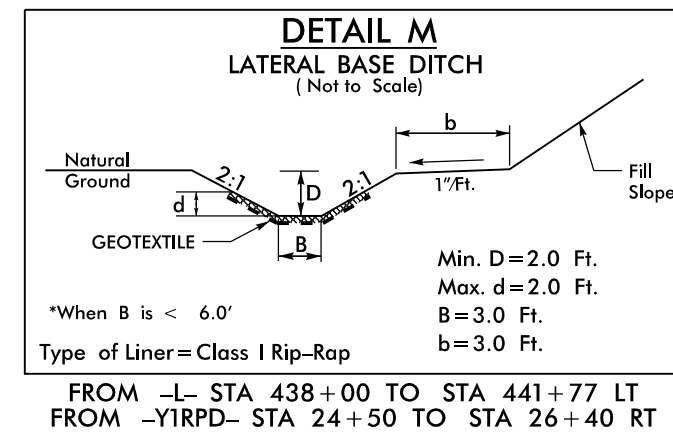
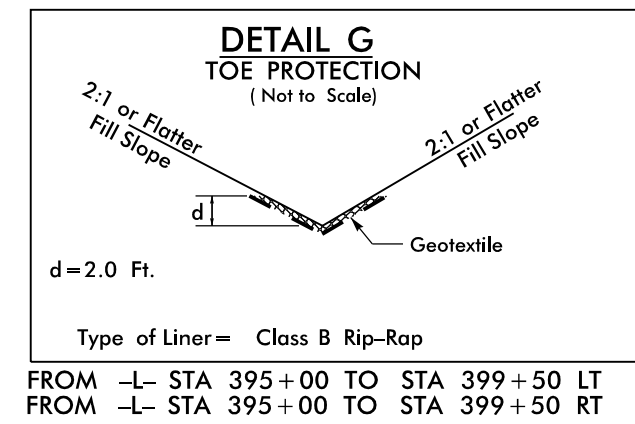
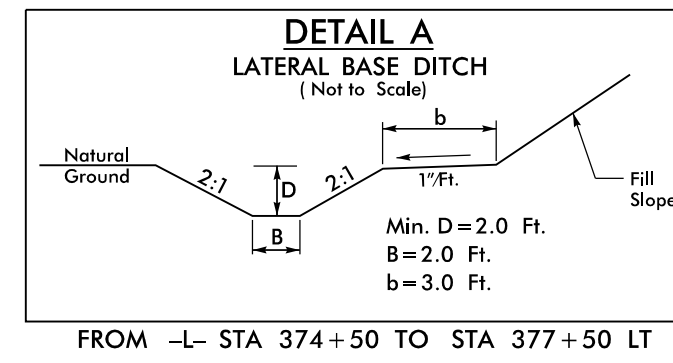

5/14/99
15-MAR-2017 10:41 AM
C:\Roadway\2017\2579C\Revised\Detail_Drainage_20-1.dgn

PROJECT REFERENCE NO.	SHEET NO.
U-2579C	5
RW SHEET NO.	
ROADWAY DESIGN ENGINEER	HYDRAULICS ENGINEER
DOCUMENT NOT CONSIDERED FINAL UNLESS ALL SIGNATURES COMPLETED	

REVISIONS
 RIGHT OF WAY REVISION 7/26/16 - COMBINED PARCELS 5,6,7 & 8 AS ONE PARCEL 5 AND CHANGED PROPERTY OWNER NAMES TO TRUSTEES OF OAK GROVE MORAVIAN CHURCH DB 1131 PG 1486 AND THE BOARD OF PROVINCIAL ELDERS OF THE SOUTHERN PROVINCE OF THE MORAVIAN CHURCH DB 146 PG 211, RLC
 RIGHT OF WAY REVISION 5/3/17 - ADDED TCE ON PARCEL 9, JMB

8/17/19

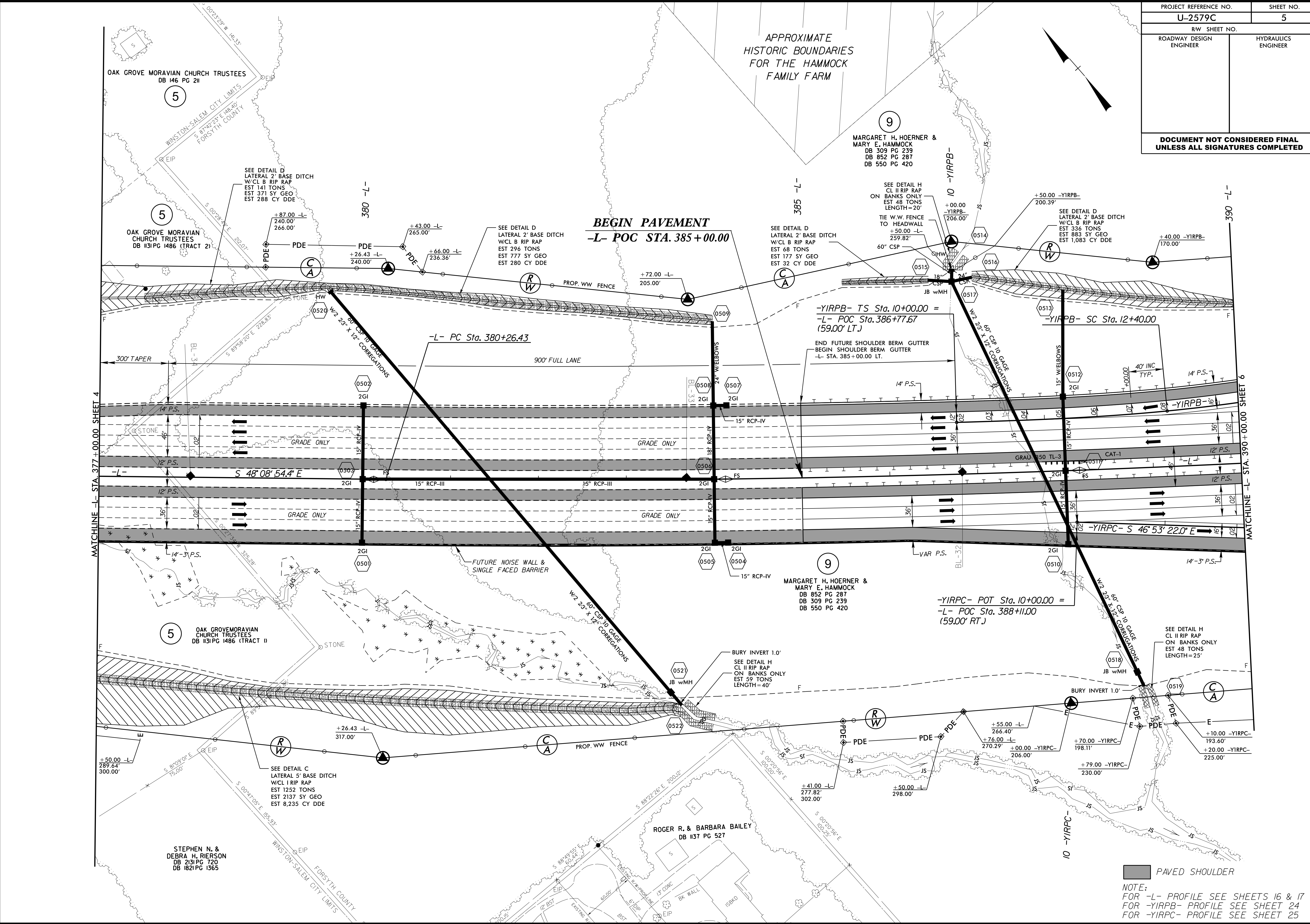

03-MAY-2017 09:38
 S:\ASSETS\PROJECTS\U-2579C\psh-5.dgn
 S:\ASSETS\PROJECTS\U-2579C\DWG\U-2579C-5.dwg

■ PAVED SHOULDER
 NOTE:
 FOR -L- PROFILE SEE SHEETS 16 & 17
 FOR -YIRPB- PROFILE SEE SHEET 24
 FOR -YIRPC- PROFILE SEE SHEET 25

PROJECT REFERENCE NO.		SHEET NO.	
U-2579C		6	
RW SHEET NO.			
ROADWAY DESIGN ENGINEER		HYDRAULICS ENGINEER	

DOCUMENT NOT CONSIDERED FINAL
UNLESS ALL SIGNATURES COMPLETED

APPROXIMATE HISTORIC BOUNDARY
FOR THE HAMMOCK
FAMILY FARM

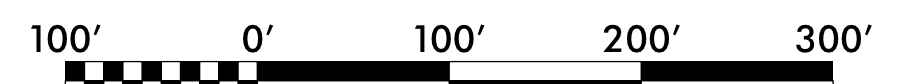

MATCHLINE -YI- STA. 39+50.00 SHEET 13

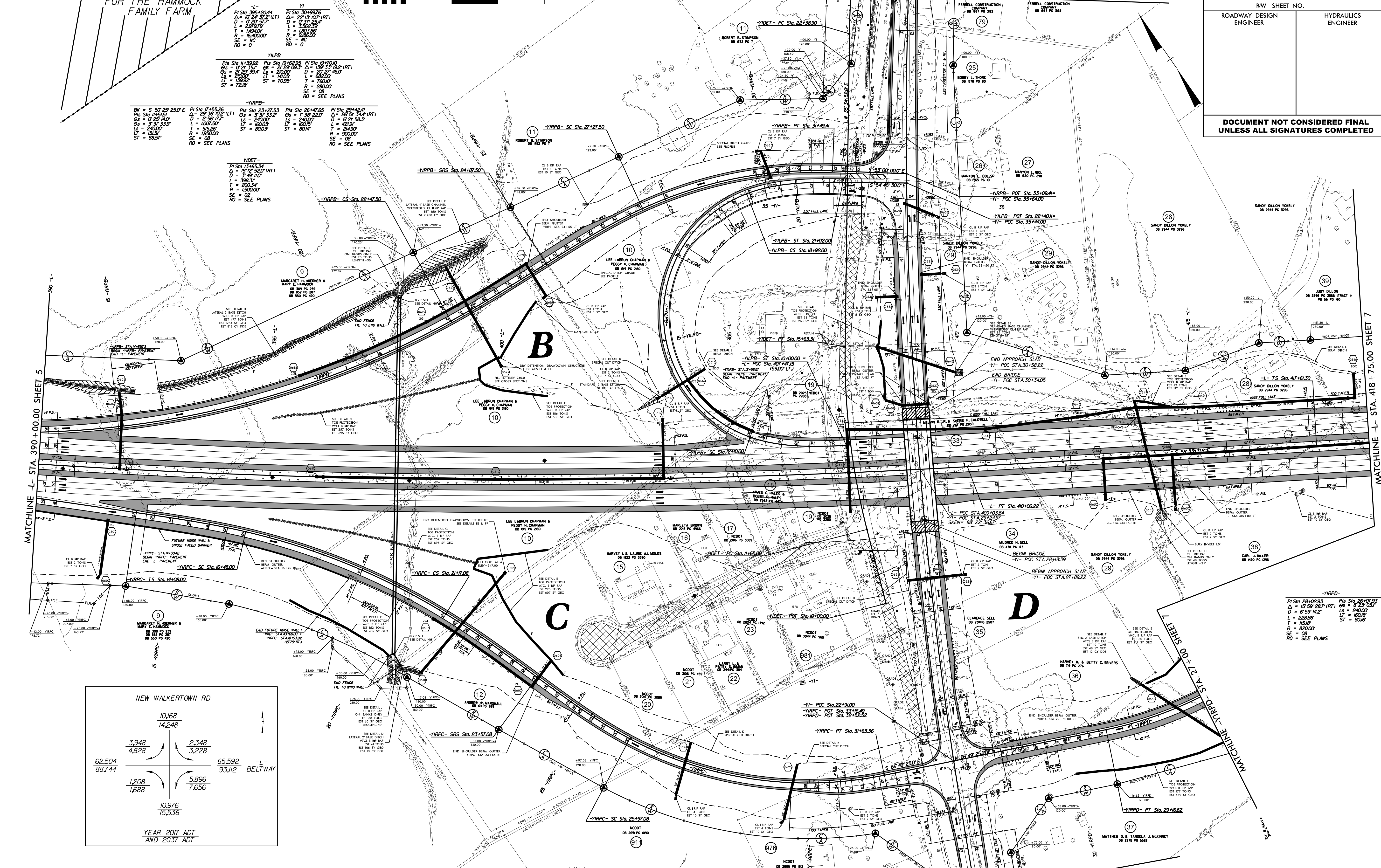

MATCHLINE -L- STA. 390+00.00 SHEET 5

MATCHLINE -L- STA. 418+75.00 SHEET 7

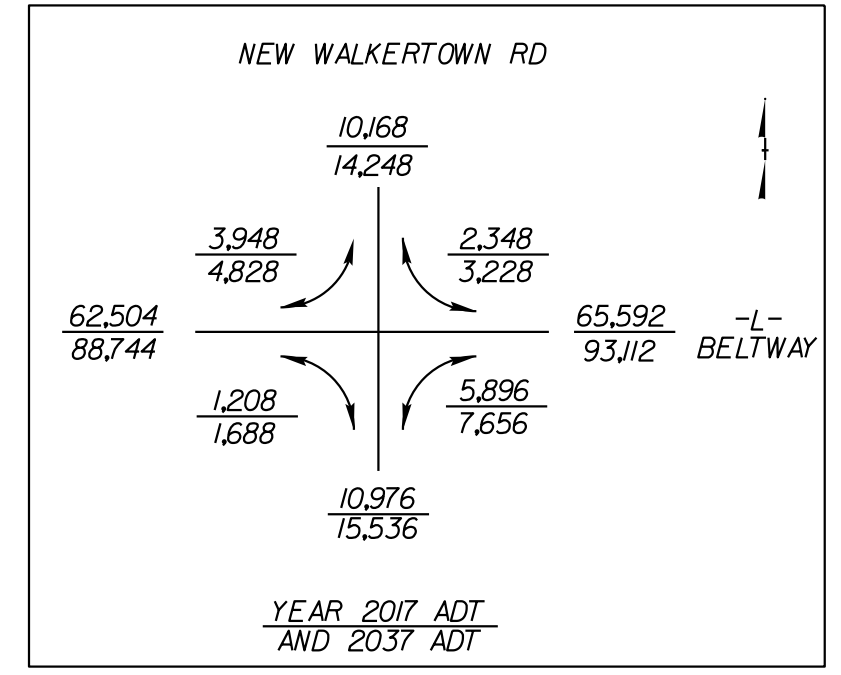

PI Sta 15+68.05	PI Sta 18+84.00	PI Sta 21+97.13	PI Sta 25+10.26	PI Sta 28+92.04
OS = 4' 4" 30.2'	OS = 18' 32" 06.7' (RT)	OS = 4' 4" 30.2'	OS = 4' 4" 30.2'	OS = 6' 59" 14.2'
LS = 240.00'	D = 3' 57" 05.2"	LS = 240.00'	LS = 240.00'	D = 6' 59" 14.2'
LT = 160.00'	L = 46.00'	LT = 160.00'	L = 46.00'	LT = 160.00'
ST = 80.00'	T = 236.00'	ST = 80.00'	ST = 80.00'	T = 294.36'
SE = 08	R = 145.000'	SE = 08	R = 145.000'	R = 820.00'
RO = 0	RO = 0	RO = 0	RO = 0	RO = 0

NOTE:
FOR -L- PROFILE, SEE SHEETS 17 & 18
FOR -YI- PROFILE, SEE SHEETS 22 & 23
FOR -YIRPB- PROFILE, SEE SHEET 24
FOR -YIRPC- PROFILE, SEE SHEETS 25 & 26
FOR -YIRPD- PROFILE, SEE SHEET 27
FOR -YILPB- PROFILE, SEE SHEET 28
FOR -YIDET- PROFILE, SEE SHEET 30
FOR -YIDET- PLAN, SEE SHEETS 2B-5 & 2B-6
FOR BRIDGE SKETCH, SEE SHEET 2B-1

PROP. CONCRETE 5" MONOLITHIC ISLAND
PAVED SHOULDER

REVISIONS
RIGHT OF WAY REVISION 3/17/17 - UPDATED PROPERTY LINE ON PARCEL 39. JMB
RIGHT OF WAY REVISION 3/29/17 - ADDED PIPE ON PARCEL 11. JMB
RIGHT OF WAY REVISION 5/31/17 - ADDED TCE ON PARCEL 9. JMB

8/17/19
03-MAY-2017 09:40 - 2579C.psh_6.dgn
S:\ASSETMANAGEMENT\2579C

PROJECT REFERENCE NO.	SHEET NO.
U-2579C	7
RW SHEET NO.	
ROADWAY DESIGN ENGINEER	HYDRAULICS ENGINEER
DOCUMENT NOT CONSIDERED FINAL UNLESS ALL SIGNATURES COMPLETED	

REVISIONS
 RIGHT OF WAY REVISION 3/7/17 - SHIFTED PROPERTY LINE BETWEEN PARCELS 39 AND 40; UPDATED PROPERTY OWNER NAME AND DEED REFERENCE ON PARCEL 40; JMB
 RIGHT OF WAY REVISION 5/3/17 - ADDED PDE ON PARCEL 37; REVISED PDE ON PARCEL 38; REVISED R/W ON PARCELS 42 AND 922; JMB

-YIRPD-

Pls Sta 22+87.78 θs = 3° 31' 33.2" Ls = 240.00' LT = 160.03' ST = 80.03'	Pls Sta 20+14.52 Δ = 11° 23' 35.4" (LT) D = 2° 56' 17.7" L = 387.75' T = 194.52' R = 1,950.00' SE = 08 RO = SEE PLANS	Pls Sta 17+40.03 θs = 3° 31' 33.2" Ls = 240.00' LT = 160.03' ST = 80.03'
--	--	--

-SRSA-

BK = S 1° 35' 47" W
 PI Sta 11+67.27
 Δ = 108° 41' 23.6" (RT)
 D = 47° 44' 47.3"
 L = 227.64'
 T = 167.27'
 R = 120.00'
 SE = RC
 RO = SEE PLANS

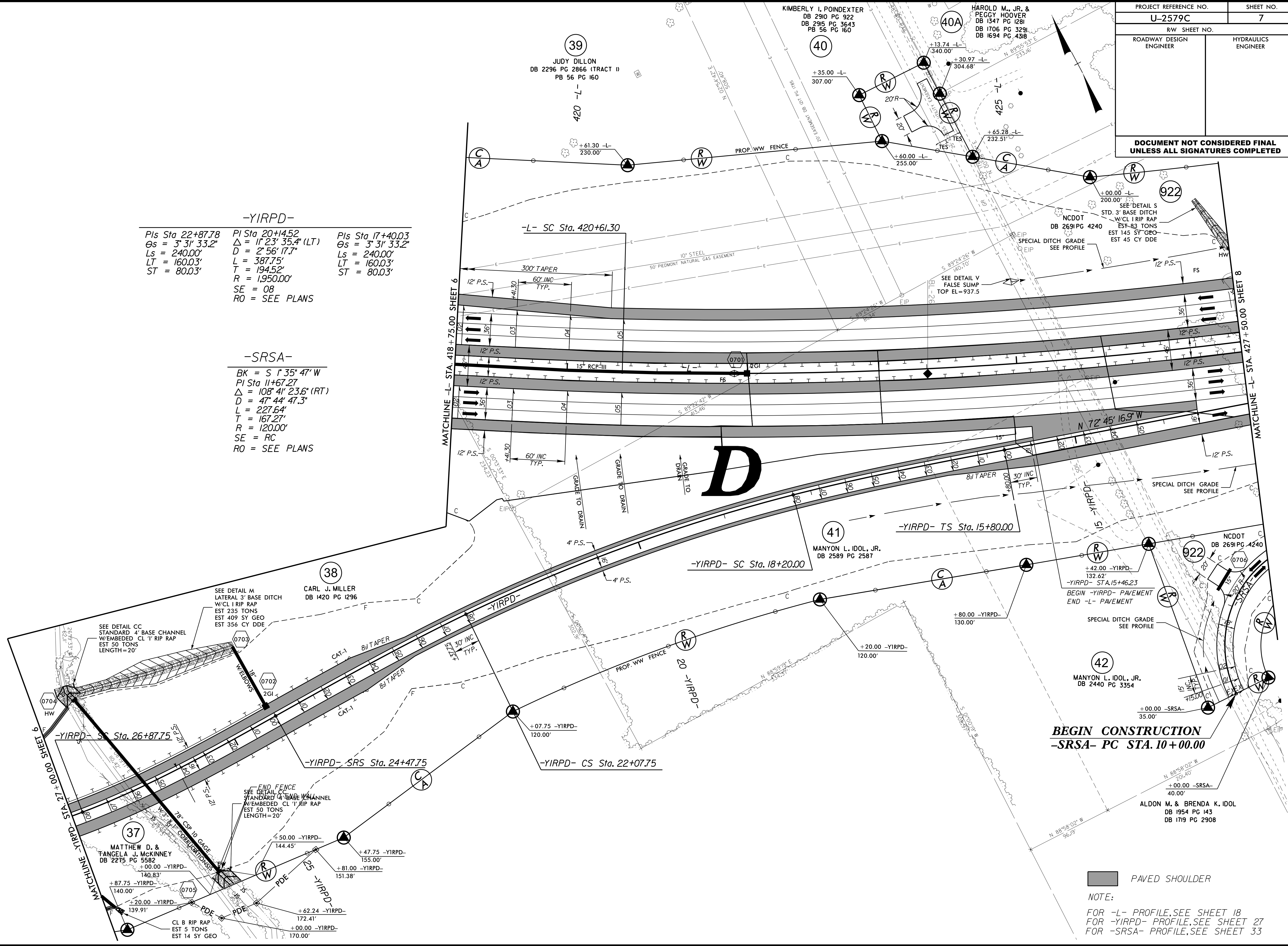

BEGIN CONSTRUCTION
-SRSA- PC STA. 10+00.00

PAVED SHOULDER
 NOTE:
 FOR -L- PROFILE, SEE SHEET 18
 FOR -YIRPD- PROFILE, SEE SHEET 27
 FOR -SRSA- PROFILE, SEE SHEET 33

03-MAY-2017 09:44
 8:48:58 AM
 2579C-ps-sh-7.dgn

PROJECT REFERENCE NO.	SHEET NO.
U-2579C	8
RW SHEET NO.	
ROADWAY DESIGN ENGINEER	HYDRAULICS ENGINEER
DOCUMENT NOT CONSIDERED FINAL UNLESS ALL SIGNATURES COMPLETED	

REVISIONS
 RIGHT OF WAY REVISION 5/3/17 - REVISED C/A FROM -L- STA. 436+00.00 TO STA. 440+00.00 RT. ON PARCELS 932 AND 977; ADDED RW ON PARCELS 55, 922, 932, 977, AND 978; ADDED TCE ON PARCELS 55 AND 932; ADDED PDE ON PARCEL 55. JMB

03 MAY 2017 09:46 U-2579C.psh.8.dgn
 8/17/99

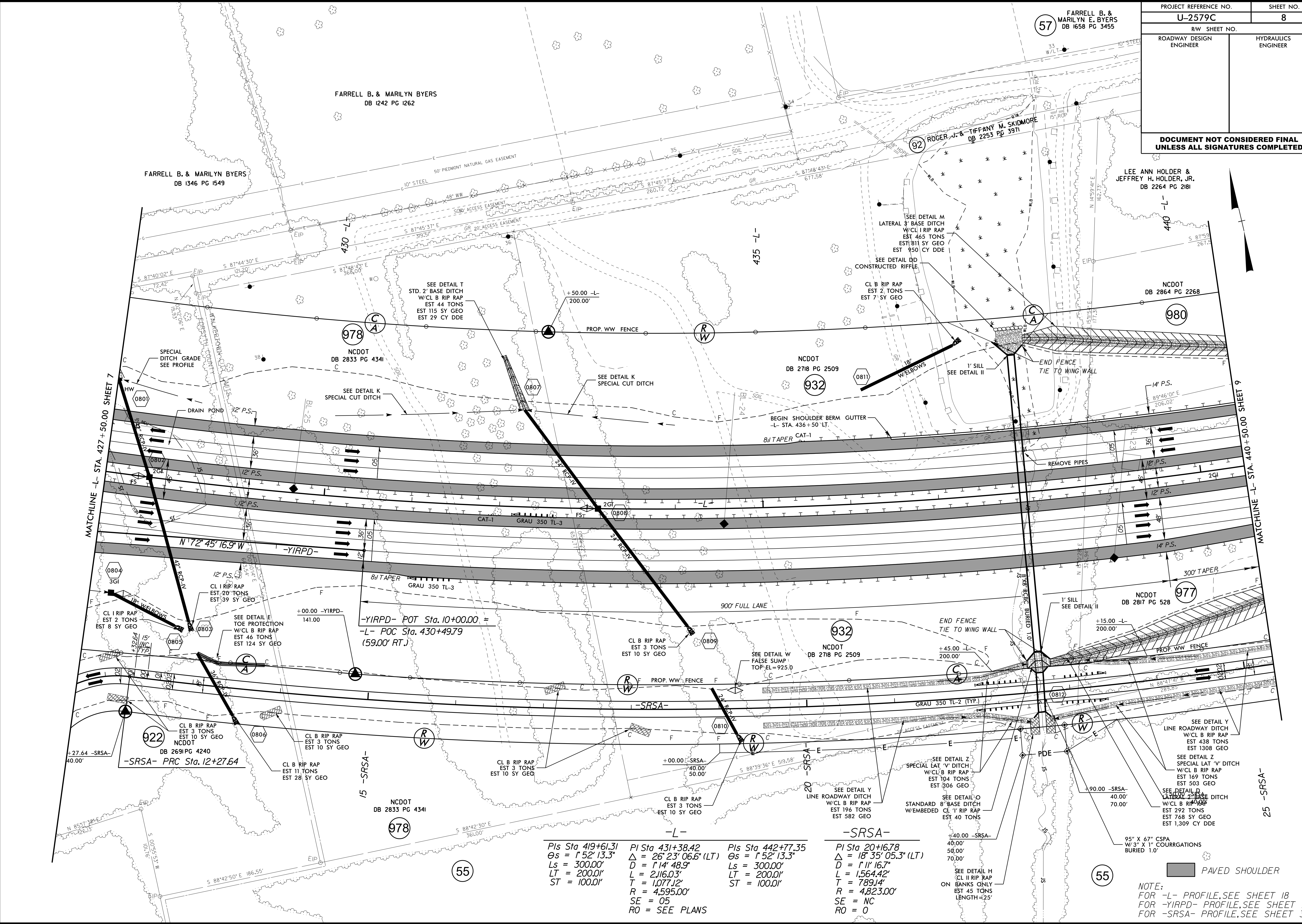

MATCHLINE -L- STA. 427 + 50.00 SHEET 7

MATCHLINE -L- STA. 440 + 50.00 SHEET 9

Pls Sta 419+61.31 $\Delta s = 1' 52' 13.3''$ $D = 300.00'$ $L = 2,116.03'$ $T = 1,077.12'$ $R = 4,595.00'$ $SE = 05$ $RO = \text{SEE PLANS}$	Pl Sta 431+38.42 $\Delta = 26' 23' 06.6''$ (LT) $D = 1' 14' 48.9''$ $L = 2,116.03'$ $T = 1,077.12'$ $R = 4,595.00'$ $SE = 05$ $RO = \text{SEE PLANS}$	Pls Sta 442+77.35 $\Delta s = 1' 52' 13.3''$ $D = 300.00'$ $L = 2,116.03'$ $T = 1,077.12'$ $R = 4,595.00'$ $SE = 05$ $RO = \text{SEE PLANS}$	Pl Sta 20+16.78 $\Delta = 18' 35' 05.3''$ (LT) $D = 1' 11' 16.7''$ $L = 1,564.42'$ $T = 789.14'$ $R = 4,823.00'$ $SE = NC$ $RO = 0$
---	--	---	--

NOTE:
 FOR -L- PROFILE, SEE SHEET 18
 FOR -YIRPD- PROFILE, SEE SHEET 27
 FOR -SRSA- PROFILE, SEE SHEET 33

PAVED SHOULDER

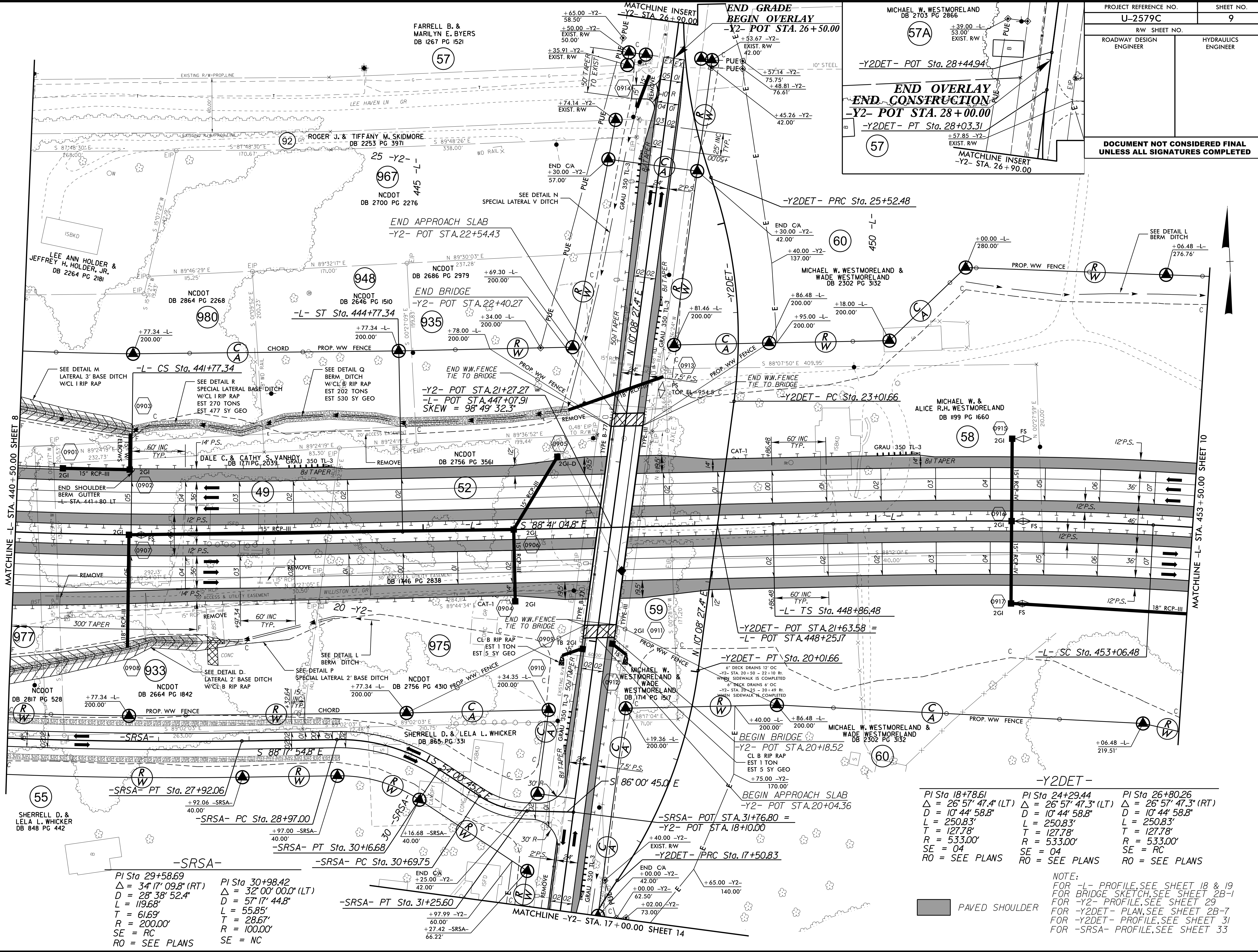
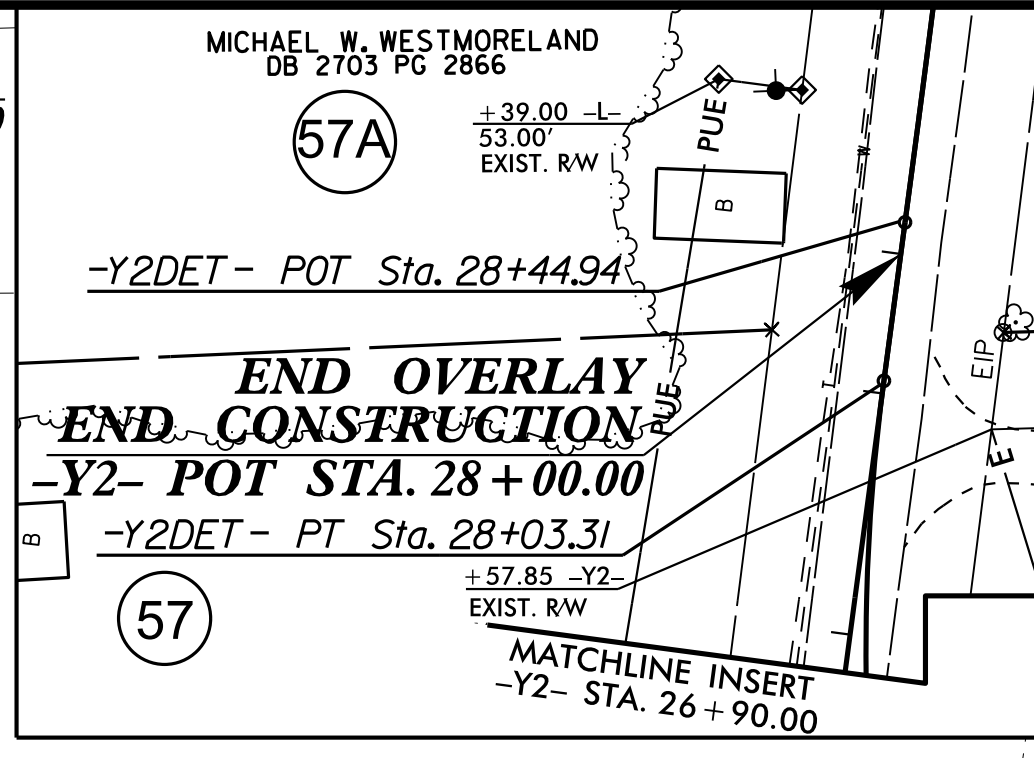

RIGHT OF WAY REVISION 12/2/16 - ADDED PARCEL 057A (MICHAEL WESTMORELAND) ABOVE PROPERTY LINE OF PARCEL 57 (FERRELL) ON INSET. JMB
 RIGHT OF WAY REVISION 5/3/17 - REMOVED REFERENCE TO PARCEL 54 BECAUSE IT IS A TRACT OF PARCEL 55; ADDED R/W ON PARCELS 933, 975, AND 977;
 REVISED R/W ON PARCEL 55; REMOVED PUE AND REVISED TCE ON PARCEL 55; ADDED TCE ON PARCEL 60. JMB

REVISIONS

03 MAY 2017 10:42:11 U:\2579C\psh_9.dgn
 5:58:58 PM JMB

PI Sta 29+58.69 Δ = 34° 17' 09.8" (RT) D = 28' 38" 52.4" L = 119.68' T = 61.69' R = 200.00' SE = RC RO = SEE PLANS	PI Sta 30+98.42 Δ = 32° 00' 00.0" (LT) D = 57' 17" 44.8" L = 55.85' T = 28.67' R = 100.00' SE = NC
---	--

PI Sta 18+78.61 Δ = 26° 57' 47.4" (LT) D = 10' 44" 58.8" L = 250.83' T = 127.78' R = 533.00' SE = 04 RO = SEE PLANS	PI Sta 24+29.44 Δ = 26° 57' 47.3" (LT) D = 10' 44" 58.8" L = 250.83' T = 127.78' R = 533.00' SE = 04 RO = SEE PLANS	PI Sta 26+80.26 Δ = 26° 57' 47.3" (RT) D = 10' 44" 58.8" L = 250.83' T = 127.78' R = 533.00' SE = RC RO = SEE PLANS
--	--	--

NOTE:
 FOR -L- PROFILE, SEE SHEET 18 & 19
 FOR BRIDGE SKETCH, SEE SHEET 2B-1
 FOR -Y2- PROFILE, SEE SHEET 29
 FOR -Y2DET- PLAN, SEE SHEET 2B-7
 FOR -Y2DET- PROFILE, SEE SHEET 31
 FOR -SRSA- PROFILE, SEE SHEET 33

PAVED SHOULDER

PROJECT REFERENCE NO.	SHEET NO.
U-2579C	10
RW SHEET NO.	
ROADWAY DESIGN ENGINEER	HYDRAULICS ENGINEER
DOCUMENT NOT CONSIDERED FINAL UNLESS ALL SIGNATURES COMPLETED	

-L-

PIs Sta 451+66.55	PI Sta 458+53.53	PIs Sta 465+27.69
$\Delta = 4' 11" 32.5"$	$\Delta = 2' 35" 01.1" (RT)$	$\Delta = 4' 11" 32.5"$
$Ls = 420.00'$	$D = 1' 59" 46.9"$	$Ls = 420.00'$
$LT = 280.08'$	$L = 1,081.14'$	$LT = 280.08'$
$ST = 140.07'$	$T = 547.06'$	$ST = 140.07'$
	$R = 2,870.00'$	
	$SE = 07$	
	$RO = \text{SEE PLANS}$	

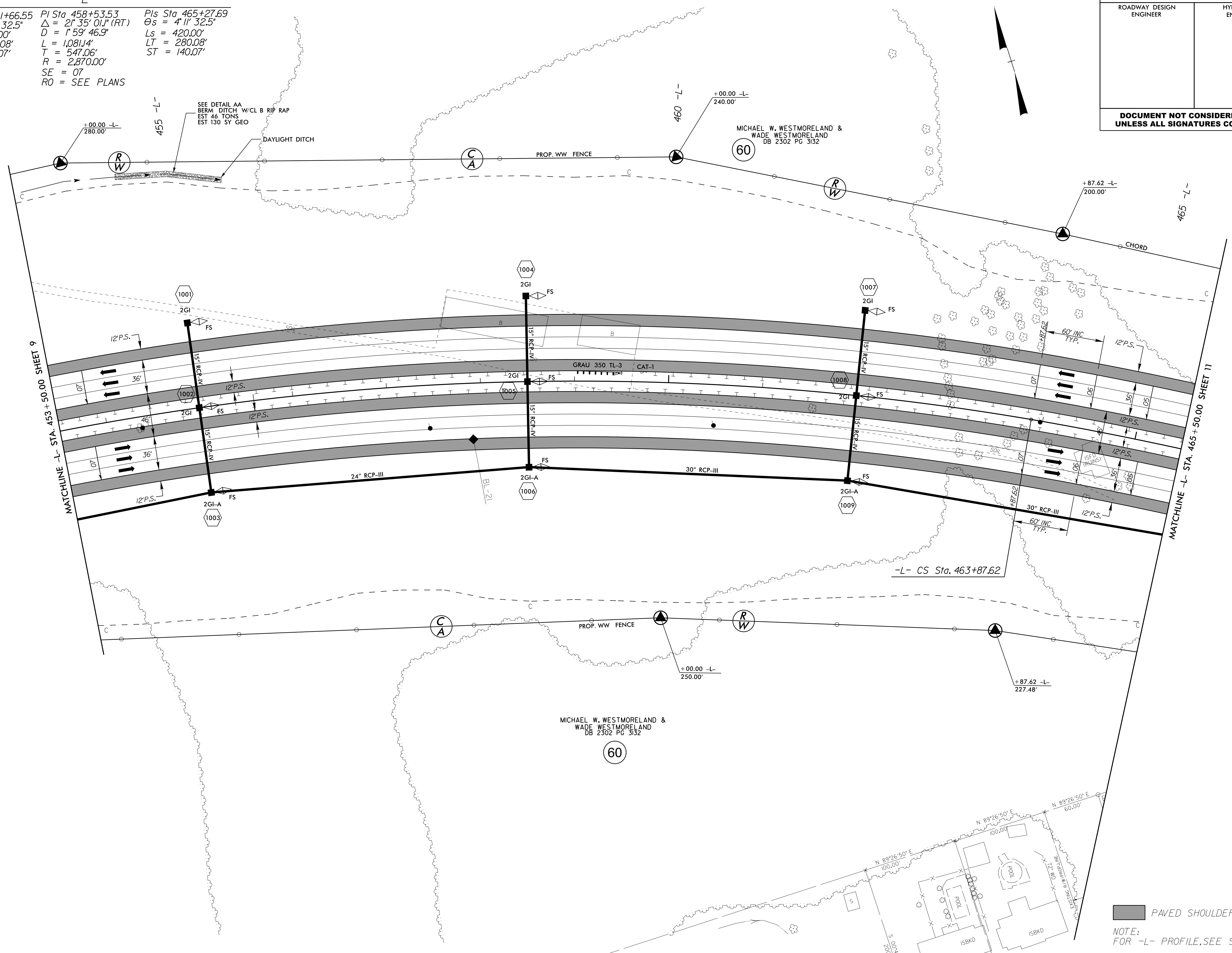

PAVED SHOULDER
 NOTE: FOR -L- PROFILE, SEE SHEET 19

8/17/99

 13-MAR-2017 18:59
 P:\Projects\2017\1859\U-2579C\psh_10.dgn
 \$\$\$\$DISPERM\$\$\$\$

PROJECT REFERENCE NO.	SHEET NO.
U-2579C	11
RW SHEET NO.	
ROADWAY DESIGN ENGINEER	HYDRAULICS ENGINEER
DOCUMENT NOT CONSIDERED FINAL UNLESS ALL SIGNATURES COMPLETED	

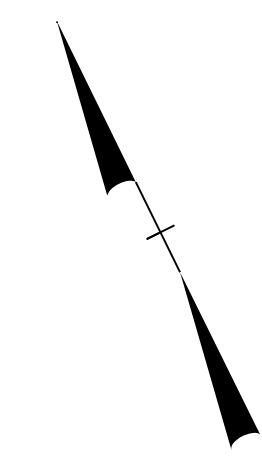

**END TIP PROJECT U-2579C
BEGIN TIP PROJECT U-2579B**
-L- POT STA. 478+00.00

JANE WHICKER &
DAN WESTMORELAND
DB 2226 PG 1302
DB 2124 PG 2239
DB 107 PG 246
DB 573 PG 367

REVISIONS

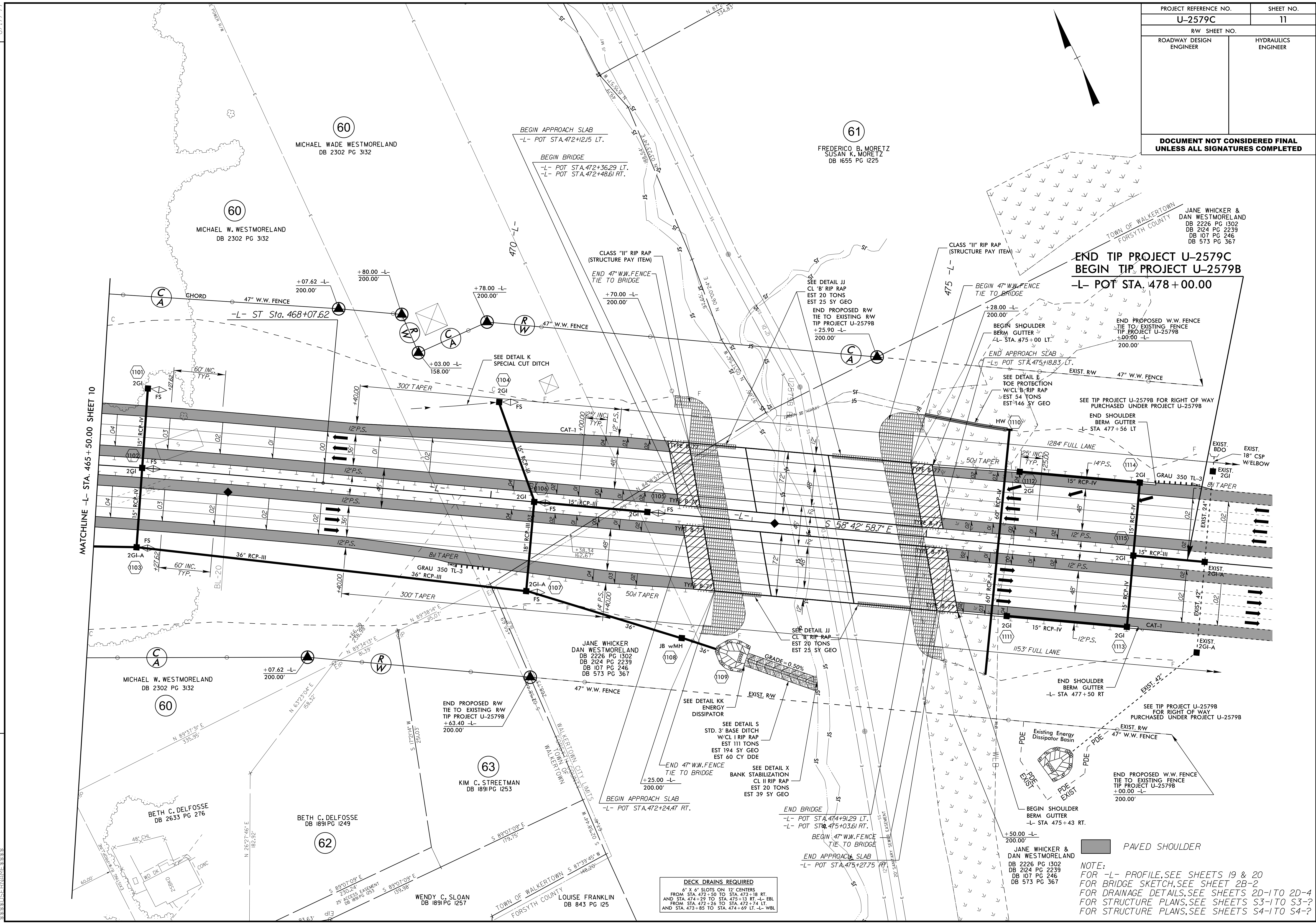

MATCHLINE -L- STA. 465+50.00 SHEET 10

DECK DRAINS REQUIRED
4" X 6" SLOTS ON 12' CENTERS
FROM STA. 472+50 TO STA. 473+18 RT.
AND STA. 474+29 TO STA. 475+13 RT. -L- EBL
FROM STA. 472+28 TO STA. 472+74 LT.
AND STA. 473+85 TO STA. 474+69 LT. -L- WBL

NOTE:
FOR -L- PROFILE, SEE SHEETS 19 & 20
FOR BRIDGE SKETCH, SEE SHEET 2B-2
FOR DRAINAGE DETAILS, SEE SHEETS 2D-1 TO 2D-4
FOR STRUCTURE PLANS, SEE SHEETS S3-1 TO S3-2
FOR STRUCTURE PLANS, SEE SHEETS S4-1 TO S4-2

24-MAY-2017 10:44
F:\Roadwork\Proj\U-2579C_psh_11.dgn
JANIS/RSR/AME

8/17/99

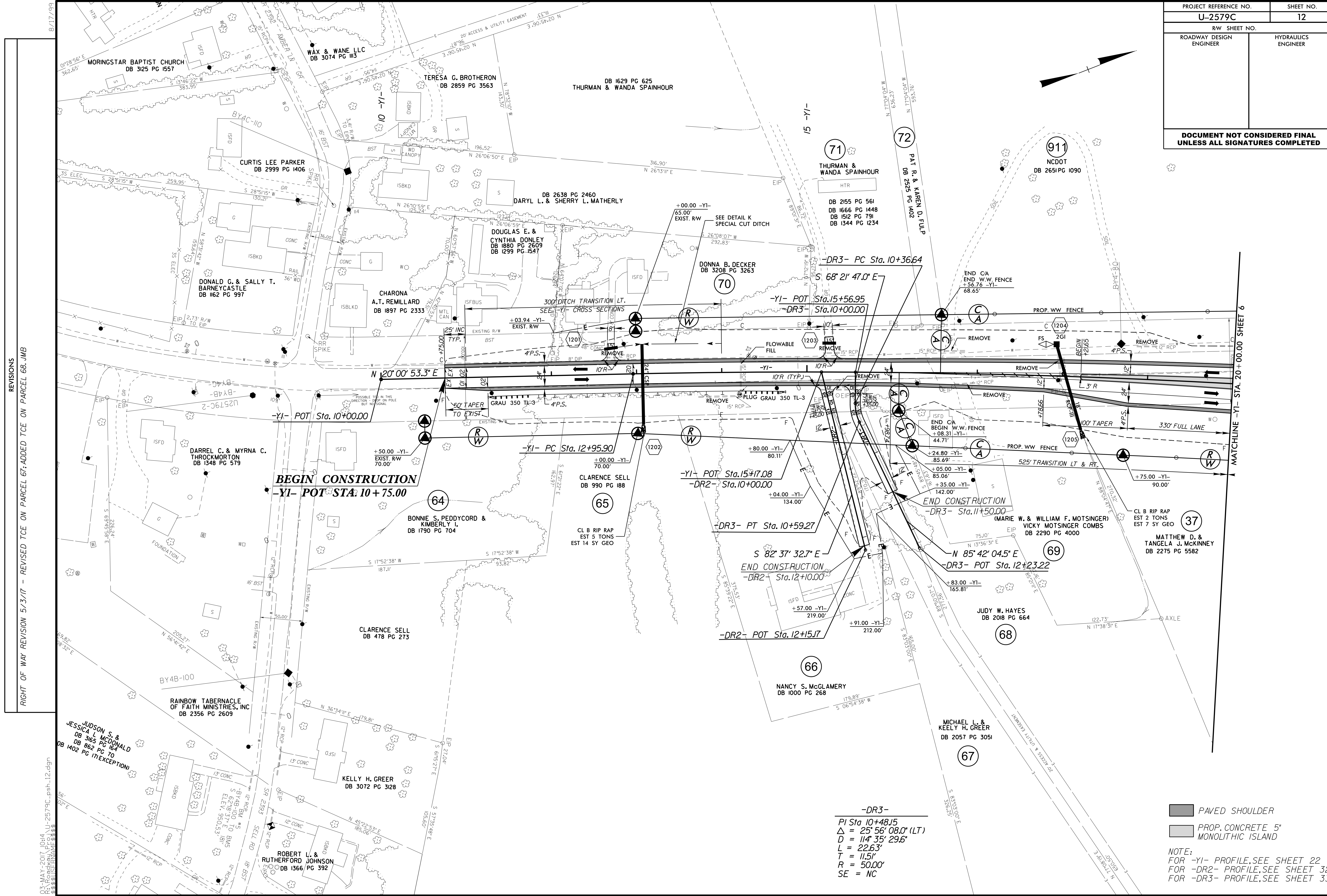

REVISIONS
RIGHT OF WAY REVISION 5/3/17 - REVISED TCE ON PARCEL 67; ADDED TCE ON PARCEL 68. JMB

-DR3-
 PI Sta 10+48.15
 $\Delta = 25^{\circ} 56' 08.0''$ (LT)
 $D = 114' 35.296''$
 $L = 226.3'$
 $T = 11.5'$
 $R = 50.00'$
 $SE = NC$

PAVED SHOULDER
 PROP. CONCRETE 5' MONOLITHIC ISLAND
 NOTE:
 FOR -Y1- PROFILE, SEE SHEET 22
 FOR -DR2- PROFILE, SEE SHEET 32
 FOR -DR3- PROFILE, SEE SHEET 33

03 MAY 2017 10:14 U:\2579C\psh_12.dgn
 3:38:58 PM
 3:38:58 PM

PROJECT REFERENCE NO.	SHEET NO.
U-2579C	13
RW SHEET NO.	
ROADWAY DESIGN ENGINEER	HYDRAULICS ENGINEER
DOCUMENT NOT CONSIDERED FINAL UNLESS ALL SIGNATURES COMPLETED	

REVISIONS
 RIGHT OF WAY REVISION 7/26/2016 - COMBINED PARCELS 74, 75, AND 76 INTO ONE PARCEL 76. ADDED OWNER NAME TO PARCEL EAST OF PARCEL 79. JMB

8.17.17.99
 14-MAR-2017 15:53
 R:\Information\U-2579C_psh_13.dgn
 \$\$\$\$DISPERNAME\$\$\$\$

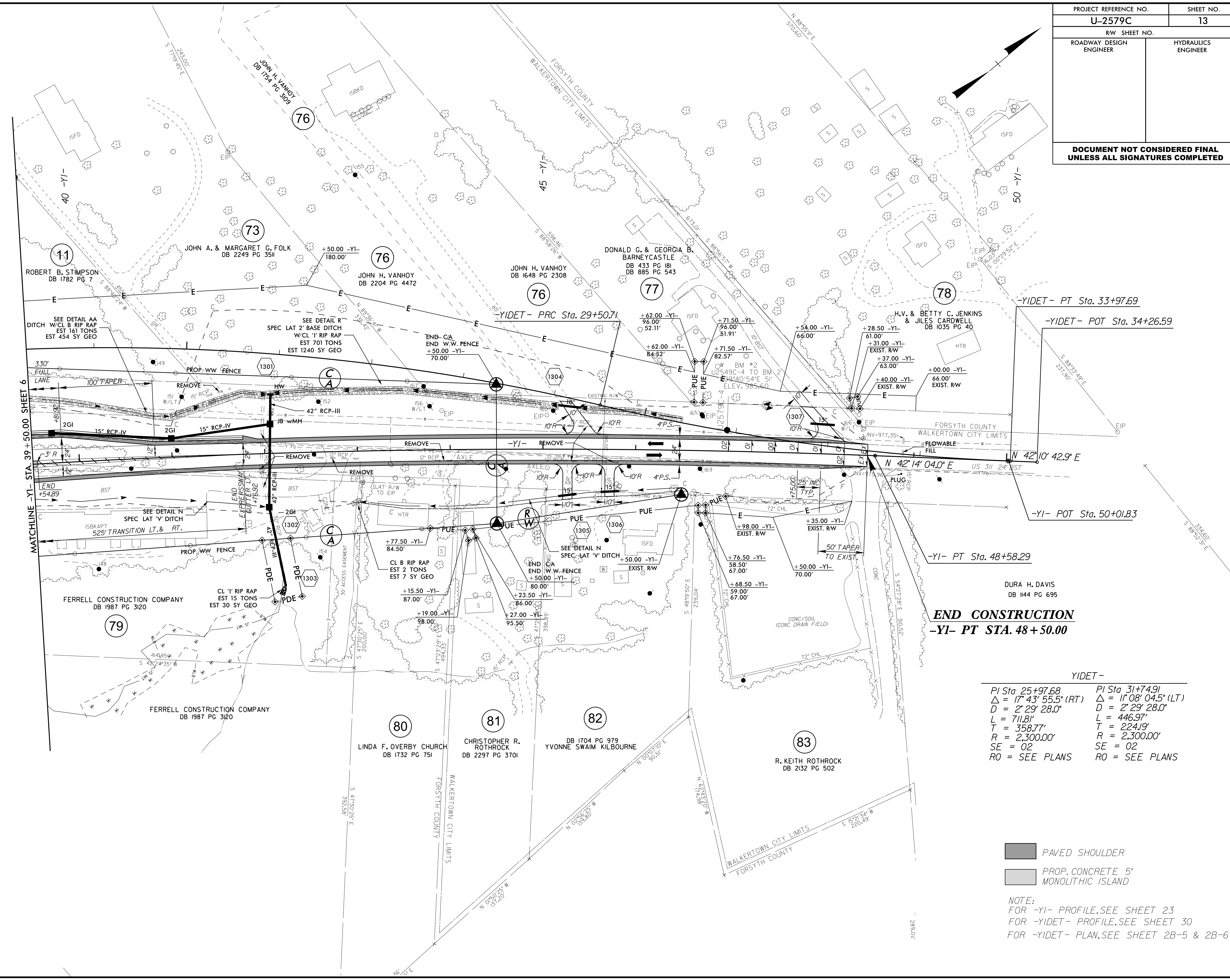

END CONSTRUCTION
 -YI- PT STA. 48+50.00

YIDET -	
PI Sta 25+97.68	PI Sta 31+74.91
$\Delta = 17^{\circ} 43' 55.5''$ (RT)	$\Delta = 1^{\circ} 08' 04.5''$ (LT)
D = 2' 29' 28.0"	D = 2' 29' 28.0"
L = 711.8'	L = 446.9'
T = 358.77'	T = 224.19'
R = 2,300.00'	R = 2,300.00'
SE = 02	SE = 02
RO = SEE PLANS	RO = SEE PLANS

- PAVED SHOULDER
- PROP. CONCRETE 5' MONOLITHIC ISLAND

NOTE:
 FOR -YI- PROFILE, SEE SHEET 23
 FOR -YIDET- PROFILE, SEE SHEET 30
 FOR -YIDET- PLAN, SEE SHEET 2B-5 & 2B-6

PROJECT REFERENCE NO.	SHEET NO.
U-2579C	14
RW SHEET NO.	
ROADWAY DESIGN ENGINEER	HYDRAULICS ENGINEER
DOCUMENT NOT CONSIDERED FINAL UNLESS ALL SIGNATURES COMPLETED	

8/17/99

REVISIONS

RIGHT OF WAY REVISION 5/3/17 - ADDED TCE ON PARCEL 60, JMB
RIGHT OF WAY REVISION 5/8/17 - REVISED PUE ON PARCEL 84, JMB

08-MAY-2017 09:24
S:\PROJECTS\U-2579C-ps-h-14.dgn
3:58:50 PM JMB

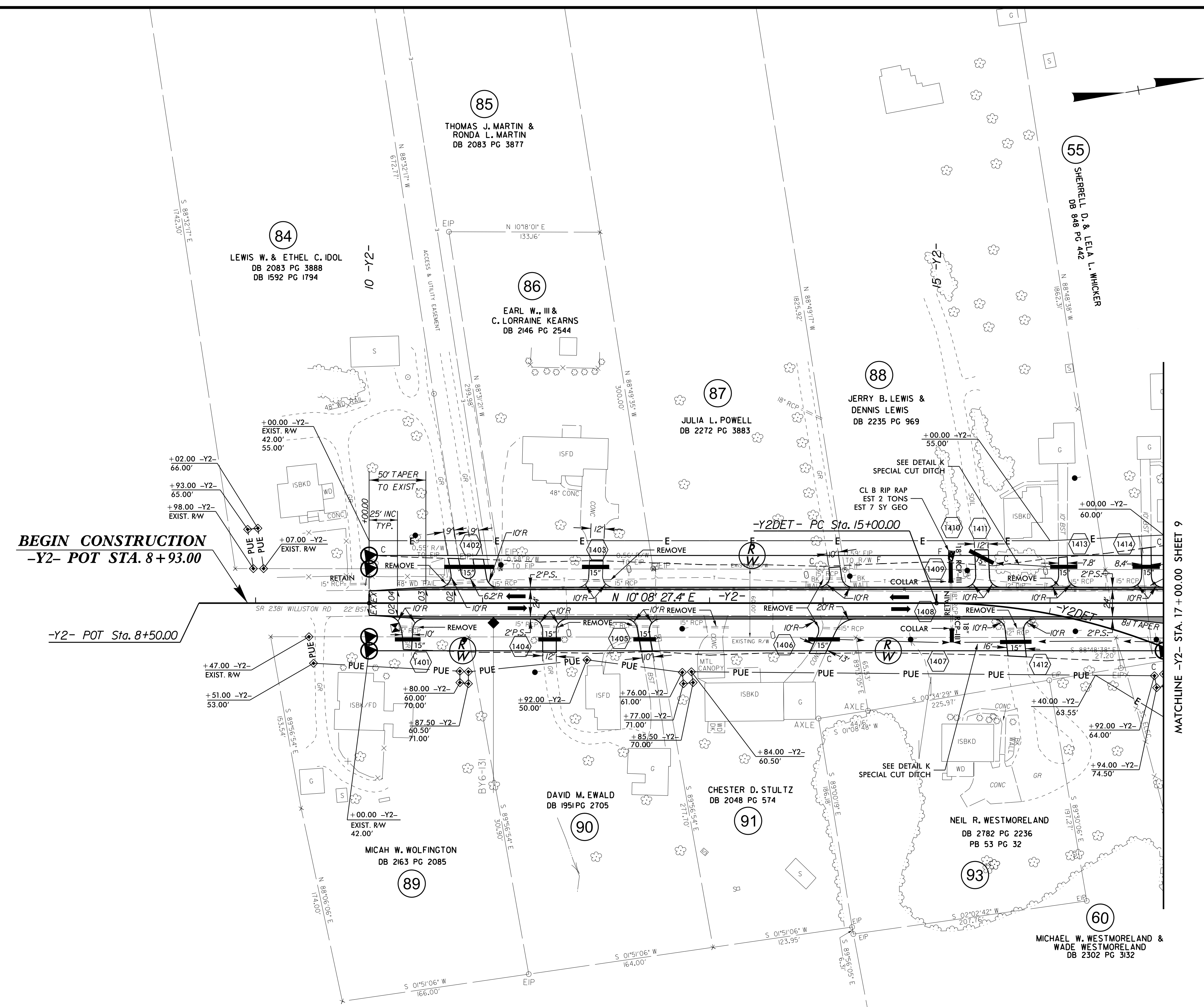

BEGIN CONSTRUCTION
-Y2- POT Sta. 8+93.00

-Y2- POT Sta. 8+50.00

MATCHLINE -Y2- STA. 17 + 00.00 SHEET 9

-Y2DET-
PI Sta 16+27.78
 $\Delta = 26' 57" 47.4" (RT)$
 $D = 10' 44" 58.8"$
 $L = 250.83'$
 $T = 127.78'$
 $R = 533.00'$
 $SE = RC$

PAVED SHOULDER

NOTE:
FOR -Y2- PROFILE, SEE SHEET 29
FOR -Y2DET- PLAN, SEE SHEET 2B-7
FOR -Y2DET- PROFILE, SEE SHEET 31