

PROJECT COMMITMENTS

T.I.P Project No. I-5507
I-485 (Charlotte Outer Loop) Express Lanes
From I-77 to US 74 (Independence Boulevard)
Mecklenburg County
WBS Element 43609.1.1

COMMITMENTS FROM PROJECT DEVELOPMENT AND DESIGN

Division 10

- There are several planned greenways (along Sugar Creek, Kings Branch, and Little Sugar Creek) under development in the project study area. NCDOT Division 10 will coordinate with Mecklenburg County Park and Recreation and the Charlotte Regional Transportation Planning Organization regarding project scheduling and/or design requirements necessary to accommodate these greenways.
- NCDOT Division 10 will coordinate with Mecklenburg County Park and Recreation prior to bridge construction over the existing McMullen Creek and McAlpine Creek Greenways regarding accommodations for greenway users during construction.
- This project involves construction activities on or adjacent to FEMA-regulated streams. Therefore, the Division will submit sealed as-built construction plans to the Hydraulics Unit upon completion of project construction, certifying that the drainage structures and roadway embankment that are located within the 100-year floodplain were built as shown in the construction plans, both horizontally and vertically.
- NCDOT Division 10 will coordinate prior to construction with Charlotte Area Transit System (CATS) to allow for necessary planning regarding mass transit routes/schedules and commuter programs in the project area.
- Site 31MK273** (Cemetery at John Dinkins Farm) is the surviving remnant of a site listed on the National Register of Historic Places. No project activities are to take place within the limits of the cemetery, including but not limited to the staging/storage of materials and/or equipment and vehicles. If Site 31MK273** is impacted in any way, additional consultation with the State Historic Preservation Office and the Charlotte-Mecklenburg Historic Landmarks Commission will be required. The design is staying within the existing right-of-way and will not impact the Cemetery at John Dinkins Farm).

NCDOT Hydraulics Unit

- During final design, the NCDOT Hydraulics Unit will coordinate with the Charlotte-Mecklenburg Storm Water Services Department and NC Floodplain Mapping Program for approval of any Conditional Letter of Map Revision (CLOMR) and subsequent Letter of Map Revision (LOMR). (There is no CLOMR/LOMR required as part of this project).

City of Charlotte/NCDOT Local Programs Management Office

- The City of Charlotte and NCDOT LPMO will complete a municipal agreement prior to construction for additional pedestrian and bicycle accommodations on bridges to be replaced carrying arterial or local streets over or under I-485 in the project area.

COMMITMENTS FROM PERMITTING

See 404 Permit and 401 Certification for special conditions developed during permitting.

**U.S. ARMY CORPS OF ENGINEERS
WILMINGTON DISTRICT**

Action Id. SAW No. 2013-02330 County: Mecklenburg U.S.G.S. Quad: NC-Weddington

GENERAL PERMIT (REGIONAL AND NATIONWIDE) VERIFICATION

Permittee: North Carolina Department of Transportation
Erin Cheely
 Address: 1598 Mail Service Center
Raleigh, North Carolina 27699
 Telephone Number: 919-707-6108
 E-mail: ekcheely@ncdot.gov

Size (acres)	<u>1959.7 acres</u>	Nearest Town	<u>Charlotte</u>
Nearest Waterway	<u>McAlpine Creek</u>	River Basin	<u>Santee</u>
USGS HUC	<u>03050103 & 03040105</u>	Coordinates	Latitude: <u>35.063857</u> Longitude: <u>-80.805614</u>

Location description: The I5507 Project is located on I-485 between I-77 and US 74, in Charlotte and Matthews, Mecklenburg County, North Carolina.

Description of projects area and activity: This verification authorizes the construction of one Express Lane in each direction in the existing median of I 485, between I 77 and US 74 (Independence Boulevard). The project also includes the construction of at-grade ingress and egress access to the Express Lanes, as well as direct connector ramps, and the construction of connectors to and from the Express Lanes to local side streets. The total impacts authorized with this verification include the permanent impact to 2,427 linear feet of stream channel, which includes 1,131 linear feet of bank stabilization, the temporary impact to 1,357 linear feet of stream channel and the permanent impact to 0.83 acre of wetlands (including 0.29 acre of mechanized clearing), no temporary impact, and no hand clearing.

A RGP 31 verification was issued for this project on 12/18/2019. On 7/23/2020 a request to authorize modifications to the project design was submitted. The above totals include the revised impacts resulting from the design modifications. This modified design includes changes at Sites 4 and 5.

Revised Sites 4 and 5 Impacts

		Site 4			Site 5			Total impact change
		Original impact	Revised impact	Change in Impact	Original impact	Revised impact	Change in impact	
Wetland (acre)	Permanent fill	0.03	<0.01	-0.02	-	-		0
	Mechanized clearing	0	0.02	+0.02	-	-		
Stream (lf)	Permanent fill	181	130	-51	473	444	-29	-80
	Temporary fill	0	10	+10	10	10	0	+10

This permit verification hereby replaces the permit verification issued on December 18, 2019.

Applicable Law(s): Section 404 (Clean Water Act, 33 USC 1344)
 Section 10 (Rivers and Harbors Act, 33 USC 403)

Authorization: **RGP201902350 NC DOT Bridges Widening Projects, Interchange Improvements
 SEE ATTACHED NWP GENERAL, REGIONAL, AND/OR SPECIAL CONDITIONS**

Special Conditions

- 1) **In order to compensate for impacts associated with this permit, mitigation shall be provided in accordance with the provisions outlined on the most recent version of the attached Compensatory Mitigation Responsibility Transfer Form. The requirements of this form, including any special conditions listed on this form, are hereby incorporated as special conditions of this permit authorization.**

SAW No. 2013-02330

Your work is authorized by the above referenced permit provided it is accomplished in strict accordance with the enclosed Conditions, your original application signed and dated 10/4/2019, and revisions outlined in the 7/23/2020 letter and the ensuing record. Any violation of the attached conditions or deviation from your submitted plans may subject the permittee to a stop work order, a restoration order, a Class I administrative penalty, and/or appropriate legal action.

This verification will remain valid until the expiration date identified below unless the nationwide authorization is modified, suspended or revoked. If, prior to the expiration date identified below, the nationwide permit authorization is reissued and/or modified, this verification will remain valid until the expiration date identified below, provided it complies with all requirements of the modified nationwide permit. If the nationwide permit authorization expires or is suspended, revoked, or is modified, such that the activity would no longer comply with the terms and conditions of the nationwide permit, activities which have commenced (i.e., are under construction) or are under contract to commence in reliance upon the nationwide permit, will remain authorized provided the activity is completed within twelve months of the date of the nationwide permit's expiration, modification or revocation, unless discretionary authority has been exercised on a case-by-case basis to modify, suspend or revoke the authorization.

Activities subject to Section 404 (as indicated above) may also require an individual Section 401 Water Quality Certification. You should contact the NC Division of Water Resources (telephone 919-807-6300) to determine Section 401 requirements.

For activities occurring within the twenty coastal counties subject to regulation under the Coastal Area Management Act (CAMA), prior to beginning work you must contact the N.C. Division of Coastal Management **Morehead City, NC, at (252) 808-2808.**

This Department of the Army verification does not relieve the permittee of the responsibility to obtain any other required Federal, State or local approvals/permits.

If there are any questions regarding this verification, any of the conditions of the Permit, or the Corps of Engineers regulatory program, please contact **Crystal Amschler** at **828-271-7980, ext 4231** or **Crystal.C.Amschler@usace.army.mil**.

AMSCHLER.CRYSTAL.CA

Digitally signed by
AMSCHLER.CRYSTAL.CAMILLE.1238614178
Date: 2020.11.12 12:25:15 -05'00'

Corps Regulatory Official: **MILLE.1238614178**

Date: **11/12/2020**

Expiration Date of Verification: **5/25/2025**

The Wilmington District is committed to providing the highest level of support to the public. To help us ensure we continue to do so, please complete the Customer Satisfaction Survey located at http://corpsmapu.usace.army.mil/cm_apex/f?p=136:4:0

A. Determination of Jurisdiction:

1. There are waters, including wetlands, on the above described project area that may be subject to Section 404 of the Clean Water Act (CWA) (33 USC § 1344) and/or Section 10 of the Rivers and Harbors Act (RHA) (33 USC § 403). This preliminary determination is not an appealable action under the Regulatory Program Administrative Appeal Process (Reference 33 CFR Part 331). However, you may request an approved JD, which is an appealable action, by contacting the Corps district for further instruction. Please note, if work is authorized by either a general or nationwide permit, and you wish to request an appeal of an approved JD, the appeal must be received by the Corps and the appeal process concluded prior to the commencement of any work in waters of the United States and prior to any work that could alter the hydrology of waters of the United States.
2. There are Navigable Waters of the United States within the above described project area subject to the permit requirements of Section 10 of the Rivers and Harbors Act (RHA) (33 USC § 403) and Section 404 of the Clean Water Act (CWA) (33 USC § 1344). Unless there is a change in the law or our published regulations, this determination may be relied upon for a period not to exceed five years from the date of this notification.
3. There are waters, including wetlands, within the above described project area that are subject to the permit requirements of Section 404 of the Clean Water Act (CWA) (33 USC § 1344). Unless there is a change in the law or our published regulations, this determination may be relied upon for a period not to exceed five years from the date of this notification.
4. A jurisdiction determination was not completed with this request. Therefore, this is not an appealable action. However, you may request an approved JD, which is an appealable action, by contacting the Corps for further instruction.
5. The aquatic resources within the above described project area have been identified under a previous action. Please reference the approved and preliminary jurisdictional determinations issued 8/25/2015 and 7/1/2019 respectively. Action ID: **SAW-2013-02330**.

B. Basis For Jurisdictional Determination: See the Approved JD described in Section A5 above.

C. Attention USDA Program Participants

This delineation/determination has been conducted to identify the limits of Corps' Clean Water Act jurisdiction for the particular site identified in this request. The delineation/determination may not be valid for the wetland conservation provisions of the Food Security Act of 1985. If you or your tenant are USDA Program participants, or anticipate participation in USDA programs, you should request a certified wetland determination from the local office of the Natural Resources Conservation Service, prior to starting work.

D. Appeals Information for Approved Jurisdiction Determinations (as indicated in A2 and A3 above).

If you object to this determination, you may request an administrative appeal under Corps regulations at 33 CFR Part 331. Enclosed you will find a Notification of Appeal Process (NAP) fact sheet and Request for Appeal (RFA) form. If you request to appeal this determination you must submit a completed RFA form to the following address:

US Army Corps of Engineers
South Atlantic Division
Attn: Jason Steele, Review Officer
60 Forsyth Street SW, Room 10M15
Atlanta, Georgia 30303-8801
Phone: (404) 562-5137

In order for an RFA to be accepted by the Corps, the Corps must determine that it is complete, that it meets the criteria for appeal under 33 CFR part 331.5, and that it has been received by the Division Office within 60 days of the date of the NAP. Should you decide to submit an RFA form, it must be received at the above address by _____.

It is not necessary to submit an RFA form to the Division Office if you do not object to the determination in this correspondence.

AMSCHLER.CRYSTAL.

Digitally signed by
AMSCHLER.CRYSTAL.CAMILLE.1238614178
Date: 2020.11.12 12:27:15 -05'00'

Corps Regulatory Official: **CAMILLE.1238614178** Date of JD: **8/25/2015 and 7/1/2019**

Crystal Amschler

The Wilmington District is committed to providing the highest level of support to the public. To help us ensure we continue to do so, please complete our Customer Satisfaction Survey, located online at http://corpsmapu.usace.army.mil/cm_apex/f?p=136:4:0.

Action ID Number: SAW No. 2013-02330 County: Mecklenburg

Permittee: North Carolina Department of Transportation, Erin Cheely

Project Name: I 5507, I 485 Express Lanes, from I 77 to US 74

Date Verification Issued: 11/12/2020

Project Manager: Crystal Amschler

Upon completion of the activity authorized by this permit and any mitigation required by the permit, sign this certification and return it to the following address:

US ARMY CORPS OF ENGINEERS
WILMINGTON DISTRICT
Attn: Crystal Amschler
Asheville Regulatory Office
U.S Army Corps of Engineers
151 Patton Avenue, Room 208
Asheville, North Carolina 28801
or
Crystal.C.Amschler@usace.army.mil

Please note that your permitted activity is subject to a compliance inspection by a U. S. Army Corps of Engineers representative. Failure to comply with any terms or conditions of this authorization may result in the Corps suspending, modifying or revoking the authorization and/or issuing a Class I administrative penalty, or initiating other appropriate legal action.

I hereby certify that the work authorized by the above referenced permit has been completed in accordance with the terms and condition of the said permit, and required mitigation was completed in accordance with the permit conditions.

Signature of Permittee

Date

U.S. ARMY CORPS OF ENGINEERS
Wilmington District
Compensatory Mitigation Responsibility Transfer Form

Permittee: NCDOT, Attn: Erin Cheely
Project Name: I 5507, I 485 Express Lanes, from I 77 to US 74

Action ID: SAW-2013-02330
County: Mecklenburg

Instructions to Permittee: The Permittee must provide a copy of this form to the Mitigation Sponsor, either an approved Mitigation Bank or the North Carolina Division of Mitigation Services (NCDMS), who will then sign the form to verify the transfer of the mitigation responsibility. Once the Sponsor has signed this form, it is the Permittee's responsibility to ensure that to the U.S. Army Corps of Engineers (USACE) Project Manager identified on page two is in receipt of a signed copy of this form before conducting authorized impacts, unless otherwise specified below. If more than one mitigation Sponsor will be used to provide the mitigation associated with the permit, or if the impacts and/or the mitigation will occur in more than one 8-digit Hydrologic Unit Code (HUC), multiple forms will be attached to the permit, and the separate forms for each Sponsor and/or HUC must be provided to the appropriate mitigation Sponsors.

Instructions to Sponsor: The Sponsor must verify that the mitigation requirements (credits) shown below are available at the identified site. By signing below, the Sponsor is accepting full responsibility for the identified mitigation, regardless of whether or not they have received payment from the Permittee. Once the form is signed, the Sponsor must update the bank ledger and provide a copy of the signed form and the updated bank ledger to the Permittee, the USACE Project Manager, and the Wilmington District Mitigation Office (see contact information on page 2). The Sponsor must also comply with all reporting requirements established in their authorizing instrument.

Permitted Impacts and Compensatory Mitigation Requirements

Permitted Impacts Requiring Mitigation*: **8-digit HUC and Basin:** 03050103, Catawba River Basin

Stream Impacts (linear feet)			Wetland Impacts (acres)			
Warm	Cool	Cold	Riparian Riverine	Riparian Non-Riverine	Non-Riparian	Coastal
1,296				0.83		

*If more than one mitigation sponsor will be used for the permit, only include impacts to be mitigated by this sponsor.

Compensatory Mitigation Requirements: **8-digit HUC and Basin:** 03050103, Catawba River Basin

Stream Mitigation (credits)			Wetland Mitigation (credits)			
Warm	Cool	Cold	Riparian Riverine	Riparian Non-Riverine	Non-Riparian	Coastal
2,592				1.66		

Mitigation Site Debited: NC DMS

(List the name of the bank to be debited. For umbrella banks, also list the specific site. For NCDMS, list NCDMS. If the NCDMS acceptance letter identifies a specific site, also list the specific site to be debited).

Section to be completed by the Mitigation Sponsor

Statement of Mitigation Liability Acceptance: I, the undersigned, verify that I am authorized to approve mitigation transactions for the Mitigation Sponsor shown below, and I certify that the Sponsor agrees to accept full responsibility for providing the mitigation identified in this document (see the table above), associated with the USACE Permittee and Action ID number shown. I also verify that released credits (and/or advance credits for NCDMS), as approved by the USACE, are currently available at the mitigation site identified above. Further, I understand that if the Sponsor fails to provide the required compensatory mitigation, the USACE Wilmington District Engineer may pursue measures against the Sponsor to ensure compliance associated with the mitigation requirements.

Mitigation Sponsor Name: NCDEQ - DMS

Name of Sponsor's Authorized Representative: Beth Harmon

Beth Harmon
Signature of Sponsor's Authorized Representative

09/14/2021
Date of Signature

**USACE Wilmington District
Compensatory Mitigation Responsibility Transfer Form, Page 2**

Conditions for Transfer of Compensatory Mitigation Credit:

- Once this document has been signed by the Mitigation Sponsor and the USACE is in receipt of the signed form, the Permittee is no longer responsible for providing the mitigation identified in this form, though the Permittee remains responsible for any other mitigation requirements stated in the permit conditions.
- Construction within jurisdictional areas authorized by the permit identified on page one of this form can begin only after the USACE is in receipt of a copy of this document signed by the Sponsor, confirming that the Sponsor has accepted responsibility for providing the mitigation requirements listed herein. For authorized impacts conducted by the North Carolina Department of Transportation (NCDOT), construction within jurisdictional areas may proceed upon permit issuance; however, a copy of this form signed by the Sponsor must be provided to the USACE within 30 days of permit issuance. NCDOT remains fully responsible for the mitigation until the USACE has received this form, confirming that the Sponsor has accepted responsibility for providing the mitigation requirements listed herein.
- Signed copies of this document must be retained by the Permittee, Mitigation Sponsor, and in the USACE administrative records for both the permit and the Bank/ILF Instrument. It is the Permittee's responsibility to ensure that the USACE Project Manager (address below) is provided with a signed copy of this form.
- If changes are proposed to the type, amount, or location of mitigation after this form has been signed and returned to the USACE, the Sponsor must obtain case-by-case approval from the USACE Project Manager and/or North Carolina Interagency Review Team (NCIRT). If approved, higher mitigation ratios may be applied, as per current District guidance and a new version of this form must be completed and included in the USACE administrative records for both the permit and the Bank/ILF Instrument.

Comments/Additional Conditions:

This form is not valid unless signed below by the USACE Project Manager and by the Mitigation Sponsor on Page 1. **Once signed, the Sponsor should provide copies of this form along with an updated bank ledger to: 1) the Permittee, 2) the USACE Project Manager at the address below, and 3) the Wilmington District Mitigation Office, Attn: Todd Tugwell, 3331 Heritage Trade Drive, Suite 105, Wake Forest, NC 27587 (email: todd.tugwell@usace.army.mil).** Questions regarding this form or any of the permit conditions may be directed to the USACE Project Manager below.

USACE Project Manager: Crystal Amschler
USACE Field Office: Asheville Regulatory Field Office
US Army Corps of Engineers
151 Patton Avenue, Room 208
Asheville, NC 28801-5006

Email:

AMSCHLER.CRYSTAL.CAMILLE.1238614178

Digitally signed by
AMSCHLER.CRYSTAL.CAMILLE.1238614178
Date: 2020.11.12 12:29:50 -05'00'

[Click here to enter a date.](#)

USACE Project Manager Signature

Date of Signature

Current Wilmington District mitigation guidance, including information on mitigation ratios, functional assessments, and mitigation bank location and availability, and credit classifications (including stream temperature and wetland groupings) is available at <http://ribits.usace.army.mil>.

DEPARTMENT OF THE ARMY
Wilmington District, Corps of Engineers
69 Darlington Avenue
Wilmington, North Carolina 28403-1343

Regional General Permit No. SAW-2019-02350 (RGP 50)
Name of Permittee: North Carolina Department of Transportation
Effective Date: May 26, 2020
Expiration Date: May 25, 2025

**DEPARTMENT OF THE ARMY
REGIONAL GENERAL PERMIT**

A regional general permit (RGP) to perform work in or affecting navigable waters of the United States and waters of the United States, upon recommendation of the Chief of Engineers, pursuant to Section 10 of the Rivers and Harbors Act of March 3, 1899 (33 U.S.C. 403), and Section 404 of the Clean Water Act (33 U.S.C. 1344), is hereby issued by authority of the Secretary of the Army by the

District Commander
U.S. Army Engineer District, Wilmington
Corps of Engineers
69 Darlington Avenue
Wilmington, North Carolina 28403-1343

TO AUTHORIZE THE DISCHARGE OF DREDGED OR FILL MATERIAL IN WATERS OF THE UNITED STATES (U.S.), INCLUDING WETLANDS, ASSOCIATED WITH MAINTENANCE, REPAIR, AND CONSTRUCTION PROJECTS CONDUCTED BY THE VARIOUS DIVISIONS OF THE NORTH CAROLINA DEPARTMENT OF TRANSPORTATION (NCDOT), INCLUDING THE NCDOT DIVISION OF HIGHWAYS, RAIL, BICYCLE/PEDESTRIAN, ETC.

Activities authorized by this RGP:

- a. (1) Road widening, and/or (2) construction, maintenance, and/or repair of bridges. For bridge projects, work can include the approaches.
- b. (1) Improvement of interchanges or intersections, or (2) construction of interchanges or intersections over, or on, existing roads.

Full descriptions/terms of “a” and “b”:

a. (1) Road widening, and/or (2) construction, maintenance, and/or repair of bridges. For bridge projects, work can include the approaches.

Permanent impacts that result in a loss of waters of the U.S., excluding stream relocation(s), must be less than or equal to 500 linear feet (lf) of stream and/or one (1) acre of wetland/open water for each single and complete linear project.

Single and complete linear project. As noted in 33 CFR 330.2(i), for linear projects, the “single and complete project” (i.e., single and complete crossing) will apply to each crossing of a separate water of the U.S. (i.e., single waterbody) at that location; except that for linear projects crossing a single waterbody several times at separate and distant locations, each crossing is considered a single and complete project. However, individual channels in a braided stream or river, or individual arms of a large, irregularly-shaped wetland or lake, etc., are not separate waterbodies and crossing of such features cannot be considered separately.

Also authorized under “a”: (1) stream relocation(s) and (2) temporary impacts, such as those from temporary structures, fills, dewatering, and other work necessary to conduct the activities listed under “a”. Stream relocation(s) and temporary impacts will be evaluated independently and are not limited to the permanent loss limits of 500 lf of stream and/or 1 acre of wetland/open water (i.e., stream relocations and/or temporary impacts do not factor into these limits) for each single and complete linear project; however, if the Corps determines that the proposed stream relocation(s) and/or temporary impacts are of such magnitude that they cannot be authorized under this section (“a”) of RGP 50, even if the permanent losses from road widening, and/or construction, maintenance, and repair of bridges do not exceed the impact limits for this section (“a”) of RGP 50, an Individual Permit will be required.

If the Corps determines, on a case-by-case basis, that the concerns for the aquatic environment so indicate, he/she may exercise discretionary authority to override this RGP and require an Individual Permit.

b. (1) Improvement of interchanges or intersections, or (2) construction of interchanges or intersections, over or, on existing roads.

For activities authorized under “b”, the limits for permanent impacts that result in a loss of waters of the U.S. depend on the location of the impacts, as described below:

- In the coastal plain of North Carolina (both inner coastal plain and outer coastal plain) - permanent impacts that result in a loss of waters of the U.S., excluding stream relocation(s), must be less than or equal to 1,000 lf of stream and/or 3 acres of wetland/open water for the entire interchange or intersection project.

- All other areas of North Carolina - permanent impacts that result in a loss of waters of the U.S., excluding stream relocation(s), must be less than or equal to 1,000 lf of stream and/or 2 acres of wetland/open water for the entire interchange or intersection project.

Coastal plain – See http://saw-reg.usace.army.mil/JD/LRRs_PandT.pdf for Land Resource Areas LRRP (inner coastal plain) and LRRT (outer coastal plain).

When proposed impacts to waters of the U.S. are located both inside AND outside of the coastal plain, the Corps will determine, based on the location(s) of proposed impacts to waters of the U.S., if a project is a “coastal plain project”.

Single and complete project. For permitting purposes, each interchange or intersection is considered to be one single and complete project. For example, an interchange project cannot result in a permanent loss (excluding stream relocation), of (1) greater than 1,000 lf of stream and/or 3 acres of wetland/open water in the coastal plain OR (2) greater than 1,000 lf of stream and/or 2 acres of wetland/open water in all other areas of North Carolina.

Approach fills may be considered to be part of an interchange or intersection project if the Corps determines that inclusion of these areas meet the terms of this section (“b”) of RGP 50. Early coordination with the Corps is encouraged.

Intersections, regardless of the mode of transportation (e.g., railroad, other roadways, etc.), may be at grade or grade separated if the Corps determines that the project would meet the terms of this section (“b”) of RGP 50. Early coordination with the Corps is encouraged.

Also authorized under “b”: (1) stream relocation(s) and (2) temporary impacts, such as those from temporary structures, fills, dewatering, and other work necessary to conduct the activities listed under “b”. Stream relocation(s) and temporary impacts will be evaluated independently and are not limited to the permanent loss limits of (1) 1,000 lf of stream and/or 3 acres of wetland/open water in the coastal plain OR (2) 1,000 lf of stream and/or 2 acres of wetland/open water in all other areas of North Carolina (i.e., stream relocations and/or temporary impacts do not factor into these limits) for each interchange or intersection project; however, if the Corps determines that the proposed stream relocation(s) and/or temporary impacts are of such magnitude that they cannot be authorized under this section (“b”) of RGP 50, even if the permanent losses from improvement of interchanges or intersections, or construction of interchanges or intersections over, or on, existing roads do not exceed the impact limits for this section (“b”) of RGP 50, an Individual Permit will be required.

If the Corps determines, on a case-by-case basis, that the concerns for the aquatic environment so indicate, he/she may exercise discretionary authority to override this RGP and require an Individual Permit.

1. Special Conditions.

a. The prospective permittee must submit a pre-construction notification (PCN) and applicable supporting information to the District Engineer and receive written verification from the Corps that the proposed work complies with this RGP prior to commencing any activity authorized by this RGP.

b. If the project will not impact a designated “Area of Environmental Concern” (AEC) in the twenty* (20) counties of North Carolina covered by the North Carolina Coastal Area Management Act (CAMA) (“CAMA counties”), a consistency submission is not required. If the project will impact a designated AEC and meets the definition of “development”, the prospective permittee must obtain the required CAMA permit. Development activities shall not commence until a copy of the approved CAMA permit is furnished to the appropriate Corps Regulatory Field Office (Wilmington Field Office – 69 Darlington Avenue, Wilmington, NC 28403 or Washington Field Office – 2407 West 5th Street, Washington, NC 27889).

***The 20 CAMA counties in North Carolina include Beaufort, Bertie, Brunswick, Camden, Carteret, Chowan, Craven, Currituck, Dare, Gates, Hertford, Hyde, New Hanover, Onslow, Pamlico, Pasquotank, Pender, Perquimans, Tyrrell, and Washington.**

c. No work shall be authorized by this RGP within the 20* CAMA counties without prior consultation with the National Oceanic and Atmospheric Administration’s (NOAA) Habitat Conservation Division. For each activity reviewed by the Corps where it is determined that the activity may affect Essential Fish Habitat (EFH) for federally managed species, an EFH Assessment shall be prepared by the prospective permittee and forwarded to the Corps and NOAA Fisheries for review and comment prior to authorization of work.

d. Culverts and pipes. The following conditions [(1)-(8)] apply to the construction of culverts/pipes, and work on existing culverts/pipes.

Additionally, if the proposed work would affect an existing culvert/pipe (e.g., culvert/pipe extensions), the prospective permittee must include actions (in the PCN) to correct any existing deficiencies that are located:

- At the inlet and/or outlet of the existing culvert/pipe, IF these deficiencies are/were caused by the existing culvert/pipe, or
- Near the inlet or outlet of the existing culvert/pipe, IF these deficiencies are/were caused by the existing culvert/pipe.

These deficiencies may include, but are not limited to, stream over-widening, bank erosion, streambed scour, perched culvert/pipes, and inadequate water depth in culvert(s). Also note if the proposed work would address the existing deficiency or eliminate it – e.g., bank erosion on left bank, but the culvert extension will be placed in this eroded area. If the prospective permittee is unable to correct the deficiencies caused by the existing culvert/pipe, they must document the reasons in the PCN for Corps consideration.

(1) No activity may result in substantial, permanent disruption of the movement of those species of aquatic life indigenous to the waterbody, including those species that normally migrate through the area. Measures will be included that will promote the safe passage of fish and other aquatic organisms.

(2) The dimension, pattern, and profile of the stream above and below a culvert/pipe shall not be modified by widening the stream channel or by reducing the depth of the stream in connection with the construction activity. It is acceptable to use rock vanes at culvert/pipe outlets to ensure, enhance, or maintain aquatic passage. Pre-formed scour holes are acceptable when designed for velocity reduction. The width, height, and gradient of a proposed opening shall be such as to pass the average historical low flow and spring flow without adversely altering flow velocity. Spring flow will be determined from gauge data, if available. In the absence of such data, bankfull flow will be used as a comparable level.

(3) Burial/depth specifications: If the project is located within any of the 20* CAMA counties, culvert/pipe inverts will be buried at least one foot below normal bed elevation when they are placed within the Public Trust AEC and/or the Estuarine Waters AEC as designated by CAMA. If the project is located outside of the 20* CAMA counties, culvert/pipe inverts will be buried at least one foot below the bed of the stream for culverts/pipes that are greater than 48 inches in diameter. Culverts/pipes that are 48 inches in diameter or less shall be buried or placed on the stream bed as practicable and appropriate to maintain aquatic passage, to include passage during drought or low flow conditions. Every effort shall be made to maintain the existing channel slope. A waiver from the burial/depth specifications in this condition may be requested in writing. The prospective permittee is encouraged to request agency input about waiver requests as early as possible, and prior to submitting the PCN for a specific project; this will allow the agencies time to conduct a site visit, if necessary, and will prevent time delays and potential project revisions for the prospective permittee. The waiver will only be issued by the Corps if it can be demonstrated that the impacts of complying with burial requirements would result in more adverse impacts to the aquatic environment.

(4) Appropriate actions to prevent destabilization of the channel and head cutting upstream shall be incorporated in the design and placement of culverts/pipes.

(5) Culverts/pipes placed within riparian and/or riverine wetlands must be installed in a manner that does not restrict the flow and circulation patterns of waters of the U.S. Culverts/pipes placed across wetland fills purely for the purposes of equalizing surface

water do not have to be buried, but must be of adequate size and/or number to ensure unrestricted transmission of water.

(6) Bankfull flows (or less) shall be accommodated through maintenance of the existing bankfull channel cross sectional area in no more than one culvert/pipe or culvert/pipe barrel. Additional culverts/pipes or barrels at such crossings shall be allowed only to receive flows exceeding the bankfull flow. A waiver from this condition may be requested in writing; this request must be specific as to the reason(s) for the request. The waiver will be issued if it can be demonstrated that it is not practicable to comply with this condition.

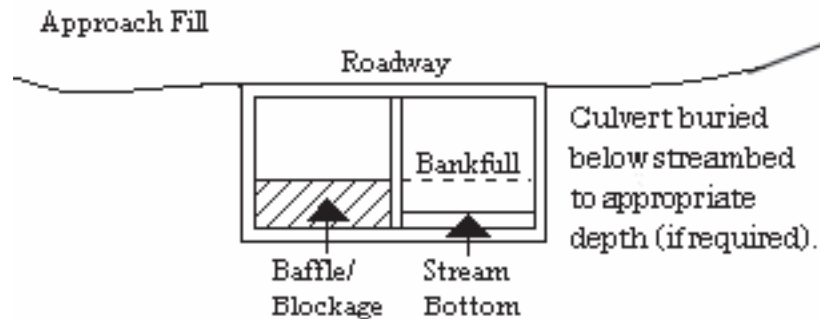

(7) Where adjacent floodplain is available, flows exceeding bankfull will be accommodated by installing culverts/pipes at the floodplain elevation. When multiple culverts/pipes are used, baseflow must be maintained at the appropriate width and depth by the construction of floodplain benches, sills, and/or construction methods to ensure that the overflow culvert(s)/pipe(s) is elevated above the baseflow culvert(s)/pipe(s).

(8) The width of the baseflow culvert/pipe shall be comparable to the width of the bankfull width of the stream channel. If the width of the baseflow culvert/pipe is wider than the stream channel, the culvert/pipe shall include baffles, benches and/or sills to maintain the width of the stream channel. A waiver from this condition may be requested in writing; this request must be specific as to the reason(s) for the request. The waiver will be issued if it can be demonstrated that it is not practicable or necessary to include baffles, benches or sills.

See the remaining special conditions for additional information about culverts/pipes in specific areas.

e. Discharges into waters of the U.S. designated by either the North Carolina Division of Marine Fisheries (NCDMF) or the North Carolina Wildlife Resources Commission (NCWRC) as anadromous fish spawning areas are prohibited during the period between February 15th and June 30th, without prior written approval from the Corps and the appropriate wildlife agencies (NCDMF, NCWRC, and/or the National Marine Fisheries Service (NMFS)). Discharges into waters of the U.S. designated by NCWRC as primary nursery areas in inland waters are prohibited during the period between February 15th and September 30th, without prior written approval from the Corps and the appropriate wildlife agencies. Discharges into waters of the U.S. designated by NCDMF as primary nursery areas shall be coordinated with NCDMF prior to being authorized by

this RGP. Coordination with NCDMF may result in a required construction moratorium during periods of significant biological productivity or critical life stages.

The prospective permittee should contact:

NC Division of Marine Fisheries
3441 Arendell Street
Morehead City, NC 28557
Telephone 252-726-7021
or 800-682-2632

North Carolina Wildlife Resources Commission
Habitat Conservation Division
1721 Mail Service Center
Raleigh, NC 27699-1721
Telephone (919) 707-0220

f. This permit does not authorize the use of culverts in areas designated as anadromous fish spawning areas by the NCDMF or the NCWRC.

g. No in-water work shall be conducted in Waters of the U.S. designated as Atlantic sturgeon critical habitat during the periods between February 1st and June 30th. No in-water work shall be conducted in Waters of the U.S. in the Roanoke River designated as Atlantic sturgeon critical habitat during the periods between February 1st and June 30th, and between August 1st to October 31st, without prior written approval from NMFS.

h. Before discharging dredged or fill material into waters of the U.S. in designated trout watersheds in North Carolina, the PCN will be sent to the NCWRC and the Corps concurrently. See <https://www.saw.usace.army.mil/Missions/Regulatory-Permit-Program/Agency-Coordination/Trout.aspx> for the designated trout watersheds. The PCN shall summarize alternatives to conducting work in waters of the U.S. in trout watersheds that were considered during the planning process and detail why alternatives were or were not selected. For proposals where (1) a bridge in a trout stream will be replaced with a culvert, or (2) a culvert will be placed in a trout stream, the PCN must also include a compensatory mitigation plan for all loss of stream bed, and details of any on-site evaluations that were conducted to determine that installation of a culvert will not adversely affect passage of fish or other aquatic biota at the project site. The evaluation information must include factors such as the proposed slope of the culvert and determinations of how the slope will be expected to allow or impede passage, the necessity of baffles and/or sills to ensure passage, design considerations to ensure that expected baseflow will be maintained for passage and that post-construction velocities will not prevent passage, site conditions that will or will not allow proper burial of the culvert, existing structures (e.g., perched culverts, waterfalls, etc.) and/or stream patterns up and downstream of the culvert site that could affect passage and bank stability, and any other considerations regarding passage. The level of detail for this information shall be based on site conditions (i.e., culverts on a slope over 3% will most likely require more information than culverts on a slope that is less than 1%, etc.). Also, in order to evaluate potential impacts, the prospective permittee will describe bedforms that will be impacted by the proposed culvert – e.g., pools, glides, riffles, etc. The NCWRC will respond to both the prospective permittee and the Corps.

i. For all activities authorized by this RGP that involve the use of riprap material for bank stabilization, the following measures shall be applied:

(1) Where bank stabilization is conducted as part of an activity, natural design, bioengineering, and/or geoengineering methods that incorporate natural durable materials, native seed mixes, and native plants and shrubs are to be utilized, as appropriate to site conditions, to the maximum extent practicable.

(2) Filter cloth must be placed underneath the riprap as an additional requirement of its use in North Carolina waters; however, the prospective permittee may request a waiver from this requirement. The waiver request must be in writing. The Corps will only issue a waiver if the prospective permittee demonstrates that the impacts of complying with this requirement would result in greater adverse impacts to the aquatic environment. Note that filter fabric is not required if the riprap will be pushed or “keyed” into the bank of the waterbody.

(3) The placement of riprap shall be limited to the areas depicted on submitted work plan drawings.

(4) Riprap shall not be placed in a manner that prevents or impedes fish passage.

(5) Riprap shall be clean and free from loose dirt or any pollutant except in trace quantities that will not have an adverse environmental effect.

(6) Riprap shall be of a size sufficient to prevent its movement from the authorized alignment by natural forces under normal conditions.

(7) Riprap material shall consist of clean rock or masonry material such as, but not limited to, granite, marl, or broken concrete.

j. Discharges of dredged or fill material into waters of the U.S., including wetlands, must be minimized or avoided to the maximum extent practicable.

k. Generally, off-site detours are preferred to avoid and minimize impacts to the human and natural environment; however, if an off-site detour is considered impracticable, then an on-site detour may be considered as a necessary component of the actions authorized by this RGP. Impacts from the detour may be considered temporary and may not require compensatory mitigation if the impacted area is restored to pre-construction elevations and contours after construction is complete. The permittee shall also restore natural hydrology and stream corridors (if applicable), and reestablish native vegetation/riparian corridors. If the construction of a detour (on-site or off-site) includes standard undercutting methods, removal of all material and backfilling with suitable material is required. See special condition “s” for additional information.

l. All activities authorized by this RGP shall, to the maximum extent practicable, be

conducted "in the dry", with barriers installed between work areas and aquatic habitat to protect that habitat from sediment, concrete, and other pollutants. Where concrete is utilized, measures will be taken to prevent live or fresh concrete, including bags of uncured concrete, from coming into contact with waters of the U.S. until the concrete has set and cured. All water in the work area that has been in contact with concrete shall only be returned to waters of the U.S. when it no longer poses a threat to aquatic organisms (concrete is set and cured).

m. In cases where new alignment approaches are to be constructed and the existing approach fill in waters of the U.S. is to be abandoned and no longer maintained as a roadway, the abandoned fill shall be removed and the area will be restored to pre-construction elevations and contours. The permittee shall also restore natural hydrology and stream corridors (if applicable), and reestablish native vegetation/riparian corridors, to the extent practicable. This activity may qualify as compensatory mitigation credit for the project and will be assessed on a case-by-case basis in accordance with Special Conditions "q" and "r" in this document. Any proposed on-site wetland restoration area must be void of utility conflicts and/or utility maintenance areas. A restoration plan detailing this activity will be required with the submittal of the PCN.

n. To the maximum extent practicable, the pre-construction course, condition, capacity, and location of open waters must be maintained for each activity, including stream channelization and storm water management activities, except as provided below. The activity must be constructed to withstand expected high flows. The activity must not restrict or impede the passage of normal or high flows, unless the primary purpose of the activity is to impound water or manage high flows. The activity may alter the pre-construction course, condition, capacity, and location of open waters if it benefits the aquatic environment (e.g., stream restoration or relocation activities).

o. The project must be implemented and/or conducted so that all reasonable and practicable measures to ensure that equipment, structures, fill pads, and work associated with the project do not adversely affect upstream and/or downstream reaches. Adverse effects include, but are not limited to, channel instability, scour, flooding, and/or shoreline/streambank erosion. During construction, the permittee shall routinely monitor for these effects, cease all work if/when detected, take initial corrective measures to correct actively eroding areas, and notify the Corps immediately. Permanent corrective measures may require additional authorization from the Corps.

p. All PCNs will describe sedimentation and erosion control structures and measures proposed for placement in waters of the U.S. To the maximum extent practicable, structures and measures will be depicted on maps, surveys or drawings showing location and impacts to jurisdictional wetlands and streams. In addition, appropriate soil and erosion control measures must be established and maintained during construction. All fills, temporary and permanent, must be adequately stabilized at the earliest practicable date to prevent erosion of fill material into adjacent waters or wetlands.

q. Compensatory mitigation will be required for permanent impacts resulting in a loss of waters of the U.S. due to culvert/pipe installation and other similar activities. Mitigation may be required for stream relocation projects (see Special Condition “r” below). When compensatory mitigation is required, the prospective permittee will attach a proposed mitigation plan to the PCN. Compensatory mitigation proposals will be written in accordance with currently approved Wilmington District guidance and Corps mitigation regulations, unless the purchase of mitigation credits from an approved mitigation bank or the North Carolina Division of Mitigation Services (NCDMS) is proposed to address all compensatory mitigation requirements. The Corps Project Manager will make the final determination concerning the appropriate amount and type of mitigation.

r. Stream Relocations (non-tidal only) - for the purposes of permitting, stream relocations are considered a loss of waters of the U.S. Depending on the condition and location of (1) the existing stream, and (2) the relocated channel, stream relocation(s) may provide a functional uplift. The Corps will determine if an uplift is possible based on the information submitted with the PCN. If the anticipated uplift(s) occurs, it may offset, either partially or fully, the loss associated with a stream relocation(s) - (i.e., due to the uplift, either no compensatory mitigation would be required for the stream relocation itself, or compensatory mitigation would be required at a reduced ratio).

Because the amount of potential uplift is dependent upon the condition (or quality) of the channel to be relocated, there is no pre-determined amount of uplift needed to satisfy the requirements for a successful relocation project. After performing the evaluation(s) noted in this document, the prospective permittee will propose a certain amount of uplift potential and the Corps project manager will make the final determination. Baseline conditions and subsequent monitoring must show that the relocated channel is providing/will provide aquatic function at, or above, the level provided by the baseline (pre-project) condition. If the required uplift is not achieved, the work will not be in compliance with this special condition of RGP 50 and remediation will be required through repair (and continued monitoring), or by the permittee providing compensatory mitigation (e.g., mitigation credit through an approved bank, mitigation credit through NCDMS, etc.).

Compensatory mitigation, in addition to the stream relocation activity, may be required if the Corps determines that (a) no uplift in stream function is achievable, (b) the proposed uplift in stream function is not sufficient, by itself, (c) the risks associated with achieving potential uplifts in stream function are excessive, and/or (d) the time period for achieving the potential uplifts/functional success is too great.

On-site compensatory mitigation is not the same as stream relocation. While stream relocation simply moves a stream to a nearby, geographically similar area, it does not generate mitigation credits. If NCDOT proposes to generate compensatory mitigation on a project site, NCDOT must submit a mitigation plan that complies with 33 CFR 332.4.

The prospective permittee is required to submit the following information for any proposed project that involves stream relocation, regardless of the size/length of the stream relocation (note that 1-5 below only apply to stream relocations and not to compensatory mitigation):

- (1) A statement detailing why relocating the stream is unavoidable. In order to ensure that this action is separate from a compensatory mitigation project, the need for the fill must be related to road/interchange/intersection construction or improvement, and the project must meet the requirements set forth in the full descriptions/terms of “a” and “b” on pages 2 and 3 of this permit.
- (2) An evaluation of effects on the relocated stream and buffer from utilities, or potential for impact from utility placement in the future.
- (3) An evaluation of the baseline condition of the stream to be relocated. In order to demonstrate a potential uplift, the prospective permittee must provide the baseline (pre-impact) condition of the stream that is proposed for relocation. The prospective permittee will document the baseline condition of the stream by using the Corps’ (Wilmington District’s) current functional assessment method - e.g., the North Carolina Stream Assessment Method (NCSAM). The functional assessment must be used to identify specific areas where an uplift would reasonably be expected to occur, and also show important baseline functions that will remain after the relocation.
- (4) An evaluation of the potential uplifts to stream function for the relocated channel. The amount of detail required in the plan will be commensurate with the functional capacity of the original stream and proposed uplift(s). Low functional capacity will warrant less monitoring and less detail in the plan in order to ensure that the relocated channel provides the same, or better/increased, suite of aquatic functions as the existing channel.
- (5) A proposed monitoring plan for the relocated channel (and buffer, if applicable), will be prepared in accordance with current District guidance. The level of detail needed in the plan will be directly related to the quality of baseline functions and the anticipated uplift, therefore it is recommended that a pre-application discussion occur with the Corps Project Manager as early as possible. For example, if the risk for achieving the anticipated functional uplift is moderate or low, or if there is a low amount of proposed uplift, less information and monitoring will be required in the proposed relocation plan; similar to the requirements found in the "2003 Stream Mitigation Guidelines". If the risk for uplift is higher, or if there is a high amount of proposed uplift, additional monitoring and information will be required, trending toward the prescriptions found in the most recent Wilmington District Compensatory Mitigation Guidance – e.g., the 2016 Wilmington District Stream and Wetland Compensatory Mitigation Update. All monitoring will be for at least 5 years unless the Corps project manager determines that (a) a specific project requires less than 5 years due to site conditions or limited risk/uplift potential, and/or complexity (or simplicity) of the existing channel and/or the

relocation work, or (b) the Corps project manager determines (during the monitoring period) that the 5 years of monitoring may be reduced (or that no further monitoring is required) based on monitoring information received once the stream relocation has been completed.

s. Upon completion of any work authorized by this RGP, all temporary fills (to include culverts, pipes, causeways, etc.) will be completely removed from waters of the U.S. and the areas will be restored to pre-construction elevations and contours. The permittee shall also restore natural hydrology and stream corridors (if applicable), and reestablish native vegetation/riparian corridors. This work will be completed within 60 days of completion of project construction. If this timeframe occurs while a required moratorium of this permit is in effect, the temporary fill shall be removed in its entirety within 60 days of the moratorium end date. If vegetation cannot be planted due to the time of the year, all disturbed areas will be seeded with a native mix appropriate for the impacted area, and vegetation will be planted during the next appropriate time frame. A native seed mix may contain non-invasive small grain annuals (e.g. millet and rye grain) to ensure adequate cover while native vegetation becomes established. The PCN must include a restoration plan showing how all temporary fills and structures will be removed and how the area will be restored to pre-project elevations and contours.

t. Once the authorized work in waters of the U.S. is complete, the permittee shall sign and return the compliance certificate that is attached to the RGP verification letter.

u. The District Engineer will consider any comments from Federal and/or State agencies concerning the proposed activity's compliance with the terms and conditions of this RGP.

v. The Corps may place additional special conditions, limitations, or restrictions on any verification of the use of RGP 50 on a project-by-project basis.

2. General Conditions.

a. Except as authorized by this RGP or any Corps approved modification to this RGP, no excavation, fill or mechanized land-clearing activities shall take place within waters or wetlands, at any time during construction or maintenance of the project. This permit does not authorize temporary placement or double handling of excavated or fill material within waters or wetlands outside the permitted area. This prohibition applies to all borrow and fill activities connected with the project.

b. Authorization under this RGP does not obviate the need to obtain other federal, state, or local authorizations.

c. All work authorized by this RGP must comply with the terms and conditions of the applicable CWA Section 401 Water Quality Certification for this RGP issued by the North Carolina Division of Water Resources (NCDWR).

d. The permittee shall employ all sedimentation and erosion control measures necessary to prevent an increase in sedimentation or turbidity within waters and wetlands outside of the permit area. This shall include, but is not limited to, the immediate installation of silt fencing or similar appropriate devices around all areas subject to soil disturbance or the movement of earthen fill, and the immediate stabilization of all disturbed areas. Additionally, the project must remain in full compliance with all aspects of the Sedimentation Pollution Control Act of 1973 (North Carolina General Statutes Chapter 113A Article 4).

e. The activities authorized by this RGP must not interfere with the public's right to free navigation on all navigable waters of the U.S. No attempt will be made by the permittee to prevent the full and free use by the public of all navigable waters at, or adjacent to, the authorized work for a reason other than safety.

f. The permittee understands and agrees that if future operations by the U.S. require the removal, relocation, or other alteration, of the structure or work herein authorized, or if, in the opinion of the Secretary of the Army or his authorized representative, said structure or work shall cause unreasonable obstruction to the free navigation of the navigable waters, the permittee will be required, upon due notice from the Corps, to remove, relocate, or alter the structural work or obstructions caused thereby, without expense to the U.S. No claim shall be made against the U.S. on account of any such removal or alteration.

g. The permittee, upon receipt of a notice of revocation of this RGP for the verified individual activity, may apply for an individual permit, or will, without expense to the U.S. and in such time and manner as the Secretary of the Army or his/her authorized representative may direct, restore the affected water of the U.S. to its former conditions.

h. This RGP does not authorize any activity that would conflict with a federal project's congressionally authorized purposes, established limitations or restrictions, or limit an agency's ability to conduct necessary operation and maintenance functions. Per Section 14 of the Rivers and Harbors Act of 1899, as amended (33 U.S.C. 408), no project that has the potential to take possession of or make use of for any purpose, or build upon, alter, deface, destroy, move, injure, or obstruct a federally constructed work or project, including, but not limited to, levees, dams, jetties, navigation channels, borrow areas, dredged material disposal sites, flood control projects, etc., shall be permitted unless the project has been reviewed and approved by the appropriate Corps approval authority. Permittees shall not begin the activity authorized by this RGP until notified by the Corps that the activity may proceed.

i. The permittee shall obtain a Consent to Cross Government Easement from the appropriate Corps District's Land Use Coordinator prior to any crossing of a Corps easement and/or prior to commencing construction of any structures, authorized dredging, or other work within the right-of-way of, or in proximity to, a federally designated disposal area.

j. The permittee will allow the Wilmington District Engineer or his/her representative to inspect the authorized activity at any time deemed necessary to ensure that the activity is being performed or maintained in strict accordance with the Special and General Conditions of this permit.

k. This RGP does not grant any property rights or exclusive privileges.

l. This RGP does not authorize any injury to the property or rights of others.

m. This RGP does not authorize the interference with any existing or proposed federal project.

n. In issuing this permit, the Federal Government does not assume any liability for the following:

(1) Damages to the permitted project or uses thereof as a result of other permitted or unpermitted activities or from natural causes.

(2) Damages to the permitted project or uses thereof as a result of current or future activities undertaken by or on behalf of the U.S. in the public interest.

(3) Damages to persons, property, or to other permitted or unpermitted activities or structures caused by the activity authorized by this permit.

(4) Design or construction deficiencies associated with the permitted work.

(5) Damage claims associated with any future modification, suspension, or revocation of this permit.

o. Authorization provided by this RGP may be modified, suspended or revoked in whole, or in part, if the Wilmington District Engineer, acting for the Secretary of the Army, determines that such action would be in the best public interest. The term of this RGP shall be five (5) years unless subject to modification, suspension, or revocation. Any modification, suspension, or revocation of this authorization will not be the basis for any claim for damages against the U.S. Government.

p. No activity may occur in a component of the National Wild and Scenic Rivers System, or in a river officially designated by Congress as a "study river" for possible inclusion in the system while the river is in an official study status, unless the appropriate Federal agency with direct management responsibility for such river, has determined in writing that the proposed activity will not adversely affect the Wild and Scenic designation or study status. Information on Wild and Scenic Rivers may be obtained from the appropriate Federal land management agency responsible for the designated Wild and Scenic River or "study river" (e.g., National Park Service, U.S. Forest Service, etc.).

q. Endangered Species.

(1) No activity is authorized under this RGP which is likely to directly or indirectly jeopardize the continued existence of a threatened or endangered species or a species proposed for such designation, as identified under the Federal Endangered Species Act (ESA), or which will directly or indirectly destroy or adversely modify the critical habitat of such species. No activity is authorized under this RGP which “may affect” a listed species or critical habitat, unless Section 7 consultation addressing the effects of the proposed activity has been completed.

(2) Federal agencies should follow their own procedures for complying with the requirements of the ESA. Federal prospective permittees (and when FHWA is the lead federal agency) must provide the District Engineer with the appropriate documentation to demonstrate compliance with those requirements. The District Engineer will review the documentation and determine whether it is sufficient to address ESA compliance for the RGP activity, or whether additional ESA consultation is necessary.

(3) Non-federal prospective permittees - for activities that might affect federally-listed endangered or threatened species or designated critical habitat, the PCN must include the name(s) of the endangered or threatened species that might be affected by the proposed work or that utilize the designated critical habitat that might be affected by the proposed work. The District Engineer will determine whether the proposed activity “may affect” or will have “no effect” to listed species and designated critical habitat. In cases where the non-federal prospective permittee has identified listed species or critical habitat that might be affected or is in the vicinity of the project, and has so notified the Corps, the prospective permittee shall not begin work until the Corps has provided notification that the proposed activities will have “no effect” on listed species or critical habitat, or until Section 7 consultation has been completed.

(4) As a result of formal or informal consultation with the U.S. Fish and Wildlife Service (USFWS) or NMFS, the District Engineer may add species-specific endangered species conditions to the RGP verification letter for a project.

(5) Authorization of an activity by a RGP does not authorize the “take” of a threatened or endangered species as defined under the ESA. In the absence of separate authorization (e.g., an ESA Section 10 Permit, a Biological Opinion with “incidental take” provisions, etc.) from the USFWS or the NMFS, the ESA prohibits any person subject to the jurisdiction of the U.S. to take a listed species, where “take” means to harass, harm, pursue, hunt, shoot, wound, kill, trap, capture, or collect, or to attempt to engage in any such conduct. The word “harm” in the definition of “take” means an act which actually kills or injures wildlife. Such an act may include significant habitat modification or degradation where it actually kills or injures wildlife by significantly impairing essential behavioral patterns, including breeding, feeding or sheltering.

(6) Information on the location of threatened and endangered species and their critical habitat can be obtained directly from the offices of the USFWS in North Carolina at the addresses provided below, or from the USFWS and NMFS via their world wide web pages at <http://www.fws.gov/> or <http://www.fws.gov/ipac> and <http://www.noaa.gov/fisheries.html> respectively.

USFWS offices in North Carolina:

The Asheville USFWS Office covers all NC counties west of, and including, Anson, Stanly, Davidson, Forsyth and Stokes Counties.

US Fish and Wildlife Service
Asheville Field Office
160 Zillicoa Street
Asheville, NC 28801
Telephone: (828) 258-3939

The Raleigh USFWS Office covers all NC counties east of, and including, Richmond, Montgomery, Randolph, Guilford, and Rockingham Counties.

US Fish and Wildlife Service
Raleigh Field Office
Post Office Box 33726
Raleigh, NC 27636-3726
Telephone: (919) 856-4520

r. The Wilmington District, USFWS, NCDOT, and the FHWA have conducted programmatic Section 7(a)(2) consultation for a number of federally listed species and habitat, and programmatic consultation concerning other federally listed species and/or habitat may occur in the future. The result of completed programmatic consultation is a Programmatic Biological Opinion (PBO) issued by the USFWS. These PBOs contain mandatory terms and conditions to implement the reasonable and prudent measures that are associated with “incidental take” of whichever species or critical habitat is covered by a specific PBO. Authorization under RGP 50 is conditional upon the permittee’s compliance with all the mandatory terms and conditions associated with incidental take of the applicable PBO (or PBOs), which are incorporated by reference in RGP 50. Failure to comply with the terms and conditions associated with incidental take of an applicable PBO, where a take of the federally listed species occurs, would constitute an unauthorized take by the permittee, and would also constitute permittee non-compliance with the authorization under RGP 50. If the terms and conditions of a specific PBO (or PBOs) apply to a project, the Corps will include this/these requirements in any RGP 50 verification that may be issued for a project. The USFWS is the appropriate authority to determine compliance with the terms and conditions of its PBO, and with the ESA.

s. Northern long-eared bat (NLEB) (*Myotis septentrionalis*). Standard Local Operating Procedures for Endangered Species (SLOPES) for the NLEB have been approved by the Corps and the U.S. Fish and Wildlife Service. See <http://www.saw.usace.army.mil/Missions/Regulatory-Permit-Program/Agency-Coordination/ESA/>. This SLOPES details how the Corps will make determinations of effect to the NLEB when the Corps is the lead federal agency for an NCDOT project that is located in the western 41 counties of North Carolina. This SLOPES does not address NCDOT projects (either federal or state funded) in the eastern 59 counties in North Carolina. Note that if another federal agency is the lead federal agency for a project in the western 41 counties, procedures for satisfying the requirements of Section 7(a)(2) of the ESA will be dictated by that agency and will not be applicable for consideration under the SLOPES; however, information that demonstrates the lead federal agency's (if other than the Corps) compliance with Section 7(a)(2) / 4(d) Rule for the NLEB, will be required in the PCN. Note that at the time of issuance of RGP 50, the federal listing status of the NLEB as "Threatened" is being litigated at the National level. If, as a result of litigation, the NLEB is federally listed as "Endangered", this general condition ("s") will no longer be applicable because the 4(d) Rule, and this NLEB SLOPES, will no longer apply/be valid.

t. For proposed activities the sixteen (16) counties listed below, prospective permittees must provide a copy of the PCN to the USFWS, 160 Zillicoa Street, Asheville, North Carolina 28801. This PCN must be sent concurrently to the USFWS and the Corps Project Manager for that specific county.

The 16 counties with tributaries that drain to designated critical habitat that require notification to the Asheville USFWS are: Avery, Cherokee, Forsyth, Graham, Haywood, Henderson, Jackson, Macon Mecklenburg, Mitchell, Stokes, Surry, Swain, Transylvania, Union and Yancey.

u. If the permittee discovers or observes any live, damaged, injured or dead individual of an endangered or threatened species during construction, the permittee shall immediately notify the Wilmington District Engineer so that required coordination can be initiated with the U.S. Fish and Wildlife Service and/or National Marine Fisheries Service.

v. Historic Properties.

(1) In cases where the District Engineer determines that the activity may have the potential to cause effects to properties listed, or eligible for listing, in the National Register of Historic Places (NRHP), the activity is not authorized, until the requirements of Section 106 of the National Historic Preservation Act (NHPA) have been satisfied.

(2) Federal prospective permittees (or when FHWA is the lead federal agency) should follow their own procedures for complying with the requirements of Section 106 of the NHPA. Federal prospective permittees must provide the District Engineer with the appropriate documentation to demonstrate compliance with those requirements; this includes copies of correspondence sent to all interested, federally recognized tribes and a summary statement about

tribal consultation efforts or, if the Corps enters into a Programmatic Agreement (PA) with the FHWA/NCDOT, documentation that the FHWA/NCDOT has complied with PA requirements. The District Engineer will review the documentation and determine whether it is sufficient to address Section 106 compliance for this RGP activity, or whether additional Section 106 consultation is necessary.

(3) Non-federal prospective permittees - the PCN must state which historic properties may be affected by the proposed work or include a vicinity map indicating the location of the historic properties or the potential for the presence of historic properties. Assistance regarding information on the location of or potential for the presence of historic resources can be sought from the State Historic Preservation Officer (SHPO) and/or Tribal Historic Preservation Officer (THPO), as appropriate, and the NRHP (see 33 CFR 330.4(g)). When reviewing PCNs, the District Engineer will comply with the current procedures for addressing the requirements of Section 106 of the NHPA. The District Engineer shall make a reasonable and good faith effort to carry out appropriate identification efforts, which may include background research, consultation, oral history interviews, sample field investigation, and field survey. Based on the information submitted and these efforts, the District Engineer shall determine whether the proposed activity has the potential to cause an effect on the historic properties.

(4) Section 106 consultation is not required when the Corps determines that the activity does not have the potential to cause effects on historic properties (see 36 CFR §800.3(a)).

(5) Section 110k of the NHPA (16 U.S.C. 470h-2(k)) prevents the Corps from granting a permit or other assistance to a prospective permittee who, with intent to avoid the requirements of Section 106 of the NHPA, has intentionally significantly adversely affected a historic property to which the permit will relate, or having legal power to prevent it, allowed such significant adverse effect to occur, unless the Corps, after consultation with the Advisory Council on Historic Preservation (ACHP), determines that circumstances justify granting such assistance despite the adverse effect created or permitted by the prospective permittee. If circumstances justify granting the assistance, the Corps is required to notify the ACHP and provide documentation specifying the circumstances, the degree of damage to the integrity of any historic properties affected, and proposed mitigation. This documentation must include any views obtained from the prospective permittee, SHPO/THPO, appropriate Indian tribes if the undertaking occurs on or affects historic properties on tribal lands or affects properties of interest to those tribes, and other parties known to have a legitimate interest in the impacts to the permitted activity on historic properties.

w. If you discover any previously unknown historic or archeological remains while accomplishing the activity authorized by this general permit, you must immediately notify this office of what you have found. We will initiate the Federal and state coordination required to determine if the remains warrant a recovery effort or if the site is eligible for listing in the National Register of Historic Places.

x. Permittees are advised that development activities in or near a floodway may be subject to the National Flood Insurance Program that prohibits any development, including fill, within a floodway that results in any increase in base flood elevations. This general permit does not authorize any activity prohibited by the National Flood Insurance Program.

y. The permittee must install and maintain, at his/her expense, any signal lights and signals prescribed by the U.S. Coast Guard, through regulations or otherwise, on authorized facilities. For further information, the permittee should contact Coast Guard Sector North Carolina at (910) 772-2191 or email Coast Guard Fifth District at cgd5waterways@uscg.mil.

z. The permittee must maintain any structure or work authorized by this general permit in good condition and in conformance with the terms and conditions of this general permit. The permittee is not relieved of this requirement if the permittee abandons the structure or work. Transfer in fee simple of the work authorized by this general permit will automatically transfer this general permit to the property's new owner, with all of the rights and responsibilities enumerated herein. The permittee must inform any subsequent owner of all activities undertaken under the authority of this general permit and provide the subsequent owner with a copy of the terms and conditions of this general permit.

aa. At his or her sole discretion, any time during the processing cycle, the Wilmington District Engineer may determine that this general permit will not be applicable to a specific proposal. In such case, the procedures for processing an individual permit in accordance with 33 CFR 325 will be available.

bb. Except as authorized by this general permit or any Corps approved modification to this general permit, all fill material placed in waters or wetlands shall be generated from an upland source and will be clean and free of any pollutants except in trace quantities. Metal products, organic materials (including debris from land clearing activities), or unsightly debris will not be used.

cc. Except as authorized by this general permit or any Corps approved modification to this general permit, all excavated material will be disposed of in approved upland disposal areas.

dd. Activities which have commenced (i.e., are under construction) or are under contract to commence in reliance upon this general permit will remain authorized provided the activity is completed within twelve months of the date of the general permit's expiration, modification, or revocation. Activities completed under the authorization of this general permit that were in effect at the time the activity was completed continue to be authorized by the general permit.

ee. The permittee is responsible for obtaining any "take" permits required under the USFWS's regulations governing compliance with the Migratory Bird Treaty Act or the Bald and Golden Eagle Protection Act. The permittee should contact the appropriate local office of the USFWS to determine if such "take" permits are required for a particular activity.

ff. The activity must comply with applicable FEMA approved state or local floodplain management requirements.

gg. There will be no unreasonable interference with navigation or the right of the public to riparian access by the existence or use of activities authorized by this RGP.

hh. Unless authorization to fill those specific wetlands or mudflats has been issued by the Corps, heavy equipment working in wetlands or mudflats must be placed on mats, or other measures must be taken to minimize soil disturbance.

ii. This RGP will not be applicable to proposed construction when the Wilmington District Engineer determines that the proposed activity will significantly affect the quality of the human environment and determines that an EIS must be prepared.

BY AUTHORITY OF THE SECRETARY OF THE ARMY:

CLARK.ROBERT.J Digitally signed by
AMES.10189013 CLARK.ROBERT.JAMES.1018
03 901303
Date: 2020.05.26 14:50:28
-04'00'

Robert J. Clark
Colonel, U. S. Army
District Commander



ROY COOPER

Governor

MICHAEL S. REGAN

Secretary

S. DANIEL SMITH

Director

September 21, 2020
Mecklenburg County
NCDWR Project No. 20191337v.2
I-485 Express Lanes
STIP No. I-5507

APPROVAL of MODIFICATION TO 401 WATER QUALITY CERTIFICATION with ADDITIONAL CONDITIONS

Mr. Phil Harris, III, P.E.
NCDOT Environmental Analysis Unit Manager
1598 Mail Service Center
Raleigh, NC 27699-1598

Dear Mr. Harris:

You have our approval, in accordance with the conditions listed below, for the following modifications to impacts for the purpose of adding express lanes to I-485 in southern Mecklenburg County.

The original 401 is now renewed under the newly issued Regional General Permit 201902350 with corresponding Water Quality General Certification 4135 and is no longer considered issued under the Regional General Permit 198200031.

Site 4: A reduction of 51 feet of permanent stream impacts and a change in wetland impacts of 0.02 acres of permanent fill to mechanized clearing.

Site 5: Instead of being relocated in an open channel, will now be piped

Changes to Site 4 and Site 5 are reflected below in the project's impact tables.



North Carolina Department of Environmental Quality | Division of Water Resources
512 North Salisbury Street | 1617 Mail Service Center | Raleigh, North Carolina 27699-1617
919.707.9000

Stream Impacts in the Catawba River Basin

Site	Bank Stabilization	Permanent Fill in Intermittent Stream (linear ft)	Temporary Fill in Intermittent Stream (linear ft)	Permanent Fill in Perennial Stream (linear ft)	Temporary Fill in Perennial Stream (linear ft)	Total Stream Impact (linear ft)	Stream Impacts Requiring Mitigation (linear ft)
1*	18	28	31			46	
2A	11				20	31	
3*	70			52	86	106	
<u>4</u>		<u>130</u>	<u>10</u>			<u>140</u>	
<u>5</u>				<u>444</u>	<u>10</u>	<u>454</u>	<u>444</u>
6	48		10			58	
7			680			680	
8	10	7				17	
10*	65				30	35	
11*	157				122	35	
13*	46			49	78	173	
15*	83			165	95	343	
15A	8				20	28	
16	36				20	56	
17	10		10			20	
18	13					13	
19	15				10	25	
20*	34			69	56	103	
21	13				10	23	
22*	24			140	73	164	
24*	22	6	32			28	
27	33				20	53	
28	37				20	57	
29	25				30	55	
30			33			33	
31*	20	3	30			23	
32	6				20	26	
33	40		10			50	
35	50		42			92	
36	17		25			42	
37	35		20			55	
37A	13					13	
38	32		30			62	
39	13				10	23	
40	16				24	40	
41*	33	52	75			94	
42*	20	125	32			145	
43	30		10			40	
44*	28			26	47	54	
TOTAL	1131	351	1080	945	801	3535	444

Total Stream Impact for Project: 3535 linear feet.
DWR Required Mitigation: 444 linear feet



Wetland Impacts in the Catawba River Basin

Site	Fill (ac)	Fill (temporary) (ac)	Excavation (ac)	Mechanized Clearing (ac)	Hand Clearing (ac)	Total Wetland Impact (ac)	Impacts Requiring Mitigation (ac)
2	0.08			0.02		0.10	0.10
4	0.01			0.02		0.03	0.03
9A	0.05			0.05		0.10	0.10
9B	0.07			0.07		0.14	0.14
12	0.13			<0.01		0.14	0.14
14	0.10			0.00		0.10	0.10
18	<0.01			0.04		0.05	0.05
20	0.00			<0.01		0.00	<0.01
25	0.02			0.04		0.06	0.06
26	0.00			0.01		0.01	0.01
27	<0.01			0.00		0.00	<0.01
31	<0.01			0.00		0.00	<0.01
32	0.02			0.00		0.02	0.02
33	0.01			<0.01		0.01	0.01
35	0.01			<0.01		0.01	0.01
41	0.02			0.00		0.02	0.02
42	0.03			0.00		0.03	0.03
Total	0.56	0.00	0.00	0.27	0.00	0.83	0.83

Total Wetland Impact for Project: 0.83 acres.

The project shall be constructed in accordance with your application dated received July 23, 2020. After reviewing your application, we have decided that these impacts are covered by General Water Quality Certification Number 4135. This certification corresponds to the Regional General Permit 50 issued by the Corps of Engineers. In addition, you should acquire any other federal, state or local permits before you proceed with your project including (but not limited to) Sediment and Erosion Control, Non-Discharge and Water Supply Watershed regulations. This approval will expire with the accompanying 404 permit.

This approval is valid solely for the purpose and design described in your application (unless modified below). Should your project change, you must notify the NCDWR and submit a new application. If the property is sold, the new owner must be given a copy of this Certification and approval letter, and is thereby responsible for complying with all the conditions. If total wetland fills for this project (now or in the future) exceed one acre, or of total impacts to perennial streams (now or in the future) exceed 300 linear feet, compensatory mitigation may be required as described in 15A NCAC 2H .0506 (h) (6) and (7). For this approval to remain valid, you must adhere to the conditions listed in the attached certification(s) and any additional conditions listed below.

Condition(s) of Certification:

Project Specific Conditions:

1. The Site 5 outfall at the time of submission for the 401 permit modification/renewal was documented to be fairly stable and as such no additional outlet protection was required. Additional information submitted by the design engineer via email on September 2, 2020 to demonstrate the outfall should not degrade. However, should the outlet condition degrade due to the design changes during the construction of this project, additional outlet protection will be required. Condition of the degradation will be assessed by the permitting agency. [15A NCAC 02H.0506(b)(2)]



2. The NCDOT Division Environmental Officer or Environmental Assistant will conduct a pre-construction meeting with all appropriate staff to ensure that the project supervisor and essential staff understand the potential issues with stream and pipe alignment at the permitted site. NCDWR staff shall be invited to the pre-construction meeting. [15A NCAC 02H.0506(b)(2) and (b)(3).
3. The all stream sites, except 30, 31, 32, and 33, are within a watershed with an approved TMDL for turbidity. This TMDL has maximum loading requirements for suspended solids (turbidity) to ensure water quality for human and aquatic life. To meet the loading requirements of the TMDL, which establishes protocol to help reduce waterbody impairment, erosion control measures for sensitive watersheds will be required in these areas. [15A NCAC 02H.0506(b)(2)]
4. Stream sites 30, 31, and 32 are in the 6 Mile Creek watershed which is home to the endangered freshwater mussel, *Lasmigona decorata* (Carolina Heelsplitter). For protection of a federally endangered species, sediment and erosion control measures for sensitive watersheds is required at these locations. [15A NCAC 02H.0506(b)(2)]
5. All portions of the proposed project draining to 303(d) listed watersheds that are impaired due to biological criteria exceedances (all impact sites) shall not discharge stormwater directly to surface waters. Stormwater shall be treated using appropriate best management practices (e.g., vegetated conveyances, constructed wetlands, detention ponds, etc.) prior to discharging to surface waters. [15A NCAC 02B.0200]
6. Unless otherwise approved in this certification, placement of culverts and other structures in open waters and streams, shall be placed below the elevation of the streambed by one foot for all culverts with a diameter greater than 48 inches, and 20 percent of the culvert diameter for culverts having a diameter less than 48 inches, to allow low flow passage of water and aquatic life. Design and placement of culverts and other structures including temporary erosion control measures shall not be conducted in a manner that may result in dis-equilibrium of wetlands or streambeds or banks, adjacent to or upstream and down stream of the above structures. The applicant is required to provide evidence that the equilibrium is being maintained if requested in writing by the NCDWR. If this condition is unable to be met due to bedrock or other limiting features encountered during construction, please contact the NCDWR for guidance on how to proceed and to determine whether or not a permit modification will be required. [15A NCAC 02H.0506(b)(2)]
7. If multiple pipes or barrels are required, they shall be designed to mimic natural stream cross section as closely as possible including pipes or barrels at flood plain elevation and/or sills where appropriate. Widening the stream channel should be avoided. Stream channel widening at the inlet or outlet end of structures typically decreases water velocity causing sediment deposition that requires increased maintenance and disrupts aquatic life passage. [15A NCAC 02H.0506(b)(2)]
8. Riprap shall not be placed in the active thalweg channel or placed in the streambed in a manner that precludes aquatic life passage. Bioengineering boulders or structures should be properly designed, sized and installed. [15A NCAC 02H.0506(b)(2)]
9. The stream channel shall be excavated no deeper than the natural bed material of the stream, to the maximum extent practicable. Efforts must be made to minimize impacts to the stream banks, as well as to vegetation responsible for maintaining the stream bank stability. Any applicable riparian buffer impact for access to stream channel shall be temporary and be revegetated with native riparian species. [15A NCAC 02H.0506(b)(2)]
10. The waiver for culvert burial is granted as requested. Stream bed is required to be level with the end of the culvert extension, as presented in the application. [15A NCAC 02H.0506(b)(2)]
11. Channel relocations shall be completed and stabilized, and approved on site by NCDWR staff, prior to diverting water into the new channel. Stream banks shall be matted with coir-fiber matting. Vegetation used for bank stabilization shall be limited to native riparian vegetation, and should include establishment of a vegetated buffer on both sides of the relocated channel to the maximum extent practical. Also, rip-rap may be allowed if it is necessary to maintain the physical integrity of the stream, but the applicant must provide written justification and any calculations used to determine the extent of rip-rap coverage requested. Once the stream has been turned into the new channel, it may be necessary to relocate stranded fish to the new channel to prevent fish kills. [15A NCAC 02H .0506(b)(3)]



12. The post-construction removal of any temporary bridge structures must return the project site to its preconstruction contours and elevations. The impacted areas shall be revegetated with appropriate native species. [15A NCAC 02H .0506(b)(2)]
13. As a condition of this 401 Water Quality Certification, the bridge demolition and construction must be accomplished in strict compliance with the most recent version of NCDOT's Best Management Practices for Construction and Maintenance Activities. [15A NCAC 02H .0507(d)(2) and 15A NCAC 02H .0506(b)(5)]
14. Bridge deck drains shall not discharge directly into the stream. Stormwater shall be directed across the bridge and pre-treated through site-appropriate means (grassed swales, pre-formed scour holes, vegetated buffers, etc.) before entering the stream. To meet the requirements of NCDOT's NPDES permit NCS000250 [delete if non-DOT project], please refer to the most recent version of the North Carolina Department of Transportation Stormwater Best Management Practices Toolbox manual for approved measures. [15A NCAC 02H .0507(d)(2) and 15A NCAC 02H .0506(b)(5)]
15. Bridge piles and bents shall be constructed using driven piles (hammer or vibratory) or drilled shaft construction methods. More specifically, jetting or other methods of pile driving are prohibited without prior written approval from the NCDWR first. [15A NCAC 02H.0506(b)(2)]
16. No drill slurry or water that has been in contact with uncured concrete shall be allowed to enter surface waters. This water shall be captured, treated, and disposed of properly. [15A NCAC 02H .0506(b)(3)]
17. All bridge construction shall be performed from the existing bridge, temporary work bridges, temporary causeways, or floating or sunken barges. If work conditions require barges, they shall be floated into position and then sunk. The barges shall not be sunk and then dragged into position. Under no circumstances should barges be dragged along the bottom of the surface water. [15A NCAC 02H .0506(b)(3)]
18. Pipes and culverts used exclusively to maintain equilibrium in wetlands, where aquatic life passage is not a concern, shall not be buried. These pipes shall be installed at natural ground elevation.
19. NCDOT shall be in compliance with the NCS00250 issued to the NCDOT, including the applicable requirements of the NCG01000. Please note the extra protections for the sensitive watersheds.
20. Tall fescue shall not be used in the establishment of temporary or permanent groundcover within riparian areas. For the establishment of permanent herbaceous cover, erosion control matting shall be used in conjunction with an appropriate native seed mix on disturbed soils within the riparian area and on disturbed steep slopes with the following exception. Erosion control matting is not necessary if the area is contained by perimeter erosion control devices such as silt fence, temporary sediment ditches, basins, etc. Matting should be secured in place with staples, stakes, or wherever possible, live stakes of native trees. Erosion control matting placed in riparian areas shall not contain a nylon mesh grid, which can impinge and entrap small animals. For the establishment of temporary groundcover within riparian areas, hydroseeding along with wood or cellulose based hydro mulch applied from a fertilizer- and limestone-free tank is allowable at the appropriate rate in conjunction with the erosion control measures. Discharging hydroseed mixtures and wood or cellulose mulch into surface waters is prohibited. Riparian areas are defined as a distance 25 feet landward from top of stream bank.
21. All portions of the proposed project draining to 303(d) listed watersheds that are impaired due to turbidity shall be designed, constructed, and operated with sediment and erosion control measures that meet Design Standards in Sensitive Watersheds (15A NCAC 4B .0124). However, due to the size of the project, NC DOT shall not be required to meet 15A NCAC 4B .0124(a) regarding the maximum amount of uncovered acres. [15A NCAC 02B.0200]
22. All portions of the proposed project draining to 303(d) listed watersheds that are impaired due to biological criteria exceedances shall not discharge stormwater directly to surface waters. Stormwater shall be treated using appropriate best management practices (e.g., vegetated conveyances, constructed wetlands, detention ponds, etc.) prior to discharging to surface waters. [15A NCAC 02B.0200]



23. At the Site 5 stream relocation, Class I riprap shall be used for stream bed stabilization and Class II riprap shall be used for streambank stabilization, if banks cannot be stabilized as submitted. [15A NCAC 02H.0506(b)(2)]
24. Wetland impacts in areas where the entire wetland is not a complete take, will maintain wetland status during construction as well as after the project is completed. Any wetland area that is permanently impacted from construction activities that was not permitted to be impacted could require a permit modification and additional mitigation credits. [15A NCAC 02H .0506(b)(2)]

General Conditions

1. Unless otherwise approved in this certification, placement of culverts and other structures in open waters and streams shall be placed below the elevation of the streambed by one foot for all culverts with a diameter greater than 48 inches, and 20 percent of the culvert diameter for culverts having a diameter less than 48 inches, to allow low flow passage of water and aquatic life. Design and placement of culverts and other structures including temporary erosion control measures shall not be conducted in a manner that may result in dis-equilibrium of wetlands or streambeds or banks, adjacent to or upstream and downstream of the above structures. The applicant is required to provide evidence that the equilibrium is being maintained if requested in writing by NCDWR. If this condition is unable to be met due to bedrock or other limiting features encountered during construction, please contact NCDWR for guidance on how to proceed and to determine whether or not a permit modification will be required. [15A NCAC 02H.0506(b)(2)]
2. If concrete is used during construction, a dry work area shall be maintained to prevent direct contact between curing concrete and stream water. Water that inadvertently contacts uncured concrete shall not be discharged to surface waters due to the potential for elevated pH and possible aquatic life and fish kills. [15A NCAC 02B.0200]
3. During the construction of the project, no staging of equipment of any kind is permitted in waters of the U.S., or protected riparian buffers. [15A NCAC 02H.0506(b)(2)]
4. The dimension, pattern and profile of the stream above and below the crossing shall not be modified. Disturbed floodplains and streams shall be restored to natural geomorphic conditions. [15A NCAC 02H.0506(b)(2)]
5. The use of rip-rap above the Normal High Water Mark shall be minimized. Any rip-rap placed for stream stabilization shall be placed in stream channels in such a manner that it does not impede aquatic life passage. [15A NCAC 02H.0506(b)(2)]
6. The Permittee shall ensure that the final design drawings adhere to the permit and to the permit drawings submitted for approval. [15A NCAC 02H .0507(c) and 15A NCAC 02H .0506 (b)(2) and (c)(2)]
7. All work in or adjacent to stream waters shall be conducted in a dry work area. Approved BMP measures from the most current version of NCDOT Construction and Maintenance Activities manual such as sandbags, rock berms, cofferdams and other diversion structures shall be used to prevent excavation in flowing water. [15A NCAC 02H.0506(b)(3) and (c)(3)]
8. Heavy equipment shall be operated from the banks rather than in the stream channel in order to minimize sedimentation and reduce the introduction of other pollutants into the stream. [15A NCAC 02H.0506(b)(3)]
9. All mechanized equipment operated near surface waters must be regularly inspected and maintained to prevent contamination of stream waters from fuels, lubricants, hydraulic fluids, or other toxic materials. [15A NCAC 02H.0506(b)(3)]
10. No rock, sand or other materials shall be dredged from the stream channel except where authorized by this certification. [15A NCAC 02H.0506(b)(3)]



11. Discharging hydroseed mixtures and washing out hydroseeders and other equipment in or adjacent to surface waters is prohibited. [15A NCAC 02H.0506(b)(3)]
12. The permittee and its authorized agents shall conduct its activities in a manner consistent with State water quality standards (including any requirements resulting from compliance with §303(d) of the Clean Water Act) and any other appropriate requirements of State and Federal law. If the NCDWR determines that such standards or laws are not being met (including the failure to sustain a designated or achieved use) or that State or federal law is being violated, or that further conditions are necessary to assure compliance, the NCDWR may reevaluate and modify this certification. [15A NCAC 02B.0200]
13. All fill slopes located in jurisdictional wetlands shall be placed at slopes no flatter than 3:1, unless otherwise authorized by this certification. [15A NCAC 02H.0506(b)(2)]
14. A copy of this Water Quality Certification shall be maintained on the construction site at all times. In addition, the Water Quality Certification and all subsequent modifications, if any, shall be maintained with the Division Engineer and the on-site project manager. [15A NCAC 02H .0507(c) and 15A NCAC 02H .0506 (b)(2) and (c)(2)]
15. The outside buffer, wetland or water boundary located within the construction corridor approved by this authorization shall be clearly marked by highly visible fencing prior to any land disturbing activities. Impacts to areas within the fencing are prohibited unless otherwise authorized by this certification. [15A NCAC 02H.0501 and .0502]
16. The issuance of this certification does not exempt the Permittee from complying with any and all statutes, rules, regulations, or ordinances that may be imposed by other government agencies (i.e. local, state, and federal) having jurisdiction, including but not limited to applicable buffer rules, stormwater management rules, soil erosion and sedimentation control requirements, etc.
17. The Permittee shall report any violations of this certification to the Division of Water Resources within 24 hours of discovery. [15A NCAC 02B.0506(b)(2)]
18. Upon completion of the project (including any impacts at associated borrow or waste sites), the NCDOT Division Engineer shall complete and return the enclosed "Certification of Completion Form" to notify the NCDWR when all work included in the 401 Certification has been completed. [15A NCAC 02H.0502(f)]
19. Native riparian vegetation (**ex. Salix nigra, Juncus (spp), Carex (spp), et al.**) must be reestablished in the riparian areas within the construction limits of the project by the end of the growing season following completion of construction. [15A NCAC 02B.0231(b)(6)]
20. There shall be no excavation from, or waste disposal into, jurisdictional wetlands or waters associated with this permit without appropriate modification. Should waste or borrow sites, or access roads to waste or borrow sites, be located in wetlands or streams, compensatory mitigation will be required since that is a direct impact from road construction activities.[15A NCAC 02H.0506(b)(3) and (c)(3)]
21. Erosion and sediment control practices must be in full compliance with all specifications governing the proper design, installation and operation and maintenance of such Best Management Practices in order to protect surface waters standards [15A NCAC 02H.0506(b)(3) and (c)(3)]:
 - a. The erosion and sediment control measures for the project must be designed, installed, operated, and maintained in accordance with the most recent version of the *North Carolina Sediment and Erosion Control Planning and Design Manual*.
 - b. The design, installation, operation, and maintenance of the sediment and erosion control measures must be such that they equal, or exceed, the requirements specified in the most recent version of the *North Carolina Sediment and Erosion Control Manual*. The devices shall be maintained on all construction sites, borrow sites, and waste pile (spoil) projects, including contractor-owned or leased borrow pits associated with the project.



- c. For borrow pit sites, the erosion and sediment control measures must be designed, installed, operated, and maintained in accordance with the most recent version of the *North Carolina Surface Mining Manual*.
 - d. The reclamation measures and implementation must comply with the reclamation in accordance with the requirements of the Sedimentation Pollution Control Act.
22. Sediment and erosion control measures shall not be placed in wetlands or waters unless otherwise approved by this Certification. [15A NCAC 02H.0506(b)(3) and (c)(3)]
 23. With the issuance of this 401 certification, the DWR approves the stormwater drainage and treatment designs as shown in the roadway plans and permit drawings submitted as part of the 401 application, which are incorporated by reference and are enforceable by the DWR. Significant modifications to the way stormwater is managed and conveyed, any outfalls, or stormwater control measures represented in the roadway plans or permit drawings after issuance of this 401 certification are prohibited without prior approval from the DWR.
 24. In the event that discharges of sediment or other pollutants from the drainage system outfalls are found by DWR to cause or contribute to a violation of surface water quality standards, DWR may take enforcement action, or NCDOT and DWR shall conduct an assessment and implement the appropriate best management practices necessary to adequately address NCDOT's contribution to the water quality standards violation. Implementation of such best management practices shall be made within a reasonable timeframe as agreed upon by NCDOT and DWR; and may require NCDOT to obtain a 404 Permit from the Corps and a 401 Certification from the DWR.

If you wish to contest any statement in the attached Certification you must file a petition for an administrative hearing. You may obtain the petition form from the office of Administrative hearings. You must file the petition with the office of Administrative Hearings within sixty (60) days of receipt of this notice. A petition is considered filed when it is received in the office of Administrative Hearings during normal office hours. The Office of Administrative Hearings accepts filings Monday through Friday between the hours of 8:00am and 5:00pm, except for official state holidays. The original and one (1) copy of the petition must be filed with the Office of Administrative Hearings.

The petition may be faxed-provided the original and one copy of the document is received by the Office of Administrative Hearings within five (5) business days following the faxed transmission. The mailing address for the Office of Administrative Hearings is:

Office of Administrative Hearings
6714 Mail Service Center
Raleigh, NC 27699-6714
Telephone: (919) 431-3000, Facsimile: (919) 431-3100

A copy of the petition must also be served on DEQ as follows:

Mr. Bill F. Lane, General Counsel
Department of Environmental Quality
1601 Mail Service Center

This letter completes the review of the Division of Water Resources under Section 401 of the Clean Water Act. If you have any questions, please contact Donna Hood at (704)682-2839 or donna.hood@ncdenr.gov.

Sincerely,

DocuSigned by:

Amy Chapman

9C9886312DCD474...

S. Daniel Smith, Director
Division of Water Resources



Electronic copy only distribution:

Crystal Amschler, US Army Corps of Engineers, Asheville Field Office
Joel Howard, Division 10 Acting Environmental Officer
Carla Dagnino, NC Department of Transportation
Michael Turchy, NC Department of Transportation
Amanetta Somerville, US Environmental Protection Agency
Janet Mizzi, US Fish and Wildlife Service
Marla Chambers, NC Wildlife Resources Commission
Donna Hood, NC Division of Water Resources Mooresville Regional Office
File Copy





ROY COOPER

Governor

MICHAEL S. REGAN

Secretary

S. DANIEL SMITH

Director

NCDWR Project No.: _____ County: _____

Applicant: _____

Project Name: _____

Date of Issuance of 401 Water Quality Certification: _____

Certificate of Completion

Upon completion of all work approved within the 401 Water Quality Certification or applicable Buffer Rules, and any subsequent modifications, the applicant is required to return this certificate to the 401 Transportation Permitting Unit, North Carolina Division of Water Resources, 1617 Mail Service Center, Raleigh, NC, 27699-1617. This form may be returned to NCDWR by the applicant, the applicant’s authorized agent, or the project engineer. It is not necessary to send certificates from all of these.

Applicant’s Certification

I, _____, hereby state that, to the best of my abilities, due care and diligence was used in the observation of the construction such that the construction was observed to be built within substantial compliance and intent of the 401 Water Quality Certification and Buffer Rules, the approved plans and specifications, and other supporting materials.

Signature: _____ Date: _____

Agent’s Certification

I, _____, hereby state that, to the best of my abilities, due care and diligence was used in the observation of the construction such that the construction was observed to be built within substantial compliance and intent of the 401 Water Quality Certification and Buffer Rules, the approved plans and specifications, and other supporting materials.

Signature: _____ Date: _____

Engineer’s Certification

_____ Partial _____ Final

I, _____, as a duly registered Professional Engineer in the State of North Carolina, having been authorized to observe (periodically, weekly, full time) the construction of the project for the Permittee hereby state that, to the best of my abilities, due care and diligence was used in the observation of the construction such that the construction was observed to be built within substantial compliance and intent of the 401 Water Quality Certification and Buffer Rules, the approved plans and specifications, and other supporting materials.

Signature _____ Registration No. _____

Date _____



**STATE OF NORTH CAROLINA
DEPARTMENT OF ENVIRONMENTAL QUALITY
DIVISION OF WATER RESOURCES**

WATER QUALITY GENERAL CERTIFICATION NO. 4135

GENERAL CERTIFICATION FOR PROJECTS ELIGIBLE FOR US ARMY CORPS OF ENGINEERS

- **NATIONWIDE PERMIT NUMBER 14 (LINEAR TRANSPORTATION PROJECTS), AND**
- **REGIONAL GENERAL PERMIT 198200031 (NCDOT BRIDGES, WIDENING PROJECTS, INTERCHANGE IMPROVEMENTS)**

Water Quality Certification Number 4135 is issued in conformity with the requirements of Section 401, Public Laws 92-500 and 95-217 of the United States and subject to the North Carolina Regulations in 15A NCAC 02H .0500 and 15A NCAC 02B .0200 for the discharge of fill material to surface waters and wetland areas as described in 33 CFR 330 Appendix A (B) (14) of the US Army Corps of Engineers regulations and Regional General Permit 198200031.

The State of North Carolina certifies that the specified category of activity will not violate applicable portions of Sections 301, 302, 303, 306 and 307 of the Public Laws 92-500 and 95-217 if conducted in accordance with the conditions hereinafter set forth.

Effective date: December 1, 2017

Signed this day: December 1, 2017

By

A handwritten signature in black ink, appearing to read 'Linda Culpepper', is written over a solid horizontal line.

for Linda Culpepper
Interim Director

GC4135

Activities meeting any one (1) of the following thresholds or circumstances require written approval for a 401 Water Quality Certification from the Division of Water Resources (DWR):

- a) If any of the conditions of this Certification (listed below) cannot be met; or
- b) Any temporary or permanent impacts to wetlands, open waters and/or streams, except for construction of a driveway to a single family residential lot that is determined to not be part of a larger common plan of development, as long as the driveway involves a travel lane of less than 25 feet and total stream impacts of less than 60 feet, including any topographic/slope stabilization or in-stream stabilization needed for the crossing; or
- c) Any stream relocation or stream restoration; or
- d) Any high-density project, as defined in 15A NCAC 02H .1003(2)(a) and by the density thresholds specified in 15A NCAC 02H .1017, which:
 - i. Disturbs one acre or more of land (including a project that disturbs less than one acre of land that is part of a larger common plan of development or sale); and
 - ii. Has permanent wetland, stream or open water impacts; and
 - iii. Is proposing new built-upon area; and
 - iv. Does not have a stormwater management plan reviewed and approved under a state stormwater program¹ or a state-approved local government stormwater program².

Projects that have vested rights, exemptions, or grandfathering from state or locally-implemented stormwater programs and projects that satisfy state or locally-implemented stormwater programs through use of community in-lieu programs **require written approval**; or

- e) Any permanent impacts to waters, or to wetlands adjacent to waters, designated as: ORW (including SAV), HQW (including PNA), SA, WS-I, WS-II, or North Carolina or National Wild and Scenic River.
- f) Any permanent impacts to waters, or to wetlands adjacent to waters, designated as Trout except for driveway projects that are below threshold (b) above provided that:
 - i. The impacts are not adjacent to any existing structures
 - ii. All conditions of this General Certification can be met, including adherence to any moratoriums as stated in Condition #10; and
 - iii. A *Notification of Work in Trout Watersheds Form* is submitted to the Division at least 60 days prior to commencement of work; or
- g) Any permanent impacts to coastal wetlands [15A NCAC 07H .0205], or Unique Wetlands (UWL); or
- h) Any impact associated with a Notice of Violation or an enforcement action for violation(s) of NC Wetland Rules (15A NCAC 02H .0500), NC Isolated Wetland Rules (15A NCAC 02H .1300), NC Surface Water or Wetland Standards (15A NCAC 02B .0200), or State Regulated Riparian Buffer Rules (15A NCAC 02B .0200); or

¹ e.g. Coastal Counties, HQW, ORW, or state-implemented Phase II NPDES

² e.g. Delegated Phase II NPDES, Water Supply Watershed, Nutrient-Sensitive Waters, or Universal Stormwater Management Program

GC4135

- i) Any impacts to subject water bodies and/or state regulated riparian buffers along subject water bodies in the Neuse, Tar-Pamlico, or Catawba River Basins or in the Randleman Lake, Jordan Lake or Goose Creek Watersheds (or any other basin or watershed with State Regulated Riparian Area Protection Rules [Buffer Rules] in effect at the time of application) *unless*:
 - i. The activities are listed as “EXEMPT” from these rules; or
 - ii. A Buffer Authorization Certificate is issued by the NC Division of Coastal Management (DCM); or
 - iii. A Buffer Authorization Certificate or a Minor Variance is issued by a delegated or designated local government implementing a state riparian buffer program pursuant to 143-215.23

Activities included in this General Certification that do not meet one of the thresholds listed above do not require written approval.

I. ACTIVITY SPECIFIC CONDITIONS:

1. If this Water Quality Certification is used to access residential, commercial or industrial building sites, then all parcels owned by the applicant that are part of the single and complete project authorized by this Certification must be buildable without additional impacts to streams or wetlands. If required in writing by DWR, the applicant shall provide evidence that the parcels are buildable without requiring additional impacts to wetlands, waters, or state regulated riparian buffers. [15A NCAC 02H .0506(b)(4) and (c)(4)]
2. For road and driveway construction purposes, this Certification shall only be utilized from natural high ground to natural high ground. [15A NCAC 02H .0506(b)(2) and (c)(2)]
3. Deed notifications or similar mechanisms shall be placed on all lots with retained jurisdictional wetlands, waters, and state regulated riparian buffers within the project boundaries in order to assure compliance with NC Wetland Rules (15A NCAC 02H .0500), NC Isolated Wetland Rules (15A NCAC 02H .1300), and/or State Regulated Riparian Buffer Rules (15A NCAC 02B .0200). These mechanisms shall be put in place at the time of recording of the property or individual parcels, whichever is appropriate. [15A NCAC 02H .0506(b)(4) and (c)(4)]
4. For the North Carolina Department of Transportation, compliance with the NCDOT’s individual NPDES permit NCS000250 shall serve to satisfy this condition. All other high-density projects that trigger threshold item (d) above shall comply with one of the following requirements: [15A NCAC 02H .0506(b)(5) and (c)(5)]

GC4135

- a. Provide a completed Stormwater Management Plan (SMP) for review and approval, including all appropriate stormwater control measure (SCM) supplemental forms and associated items, that complies with the high-density development requirements of 15A NCAC 02H .1003. Stormwater management shall be provided throughout the entire project area in accordance with 15A NCAC 02H .1003. For the purposes of 15A NCAC 02H .1003(2)(a), density thresholds shall be determined in accordance with 15A NCAC 02H .1017.
- b. Provide documentation (including calculations, photos, etc.) that the project will not cause degradation of downstream surface waters. Documentation shall include a detailed analysis of the hydrological impacts from stormwater runoff when considering the volume and velocity of stormwater runoff from the project built upon area and the size and existing condition of the receiving stream(s).

Exceptions to this condition require application to and written approval from DWR.

II. GENERAL CONDITIONS:

1. When written authorization is required, the plans and specifications for the project are incorporated into the authorization by reference and are an enforceable part of the Certification. Any modifications to the project require notification to DWR and may require an application submittal to DWR with the appropriate fee. [15A NCAC 02H .0501 and .0502]
2. No waste, spoil, solids, or fill of any kind shall occur in wetlands or waters beyond the footprint of the impacts (including temporary impacts) as authorized in the written approval from DWR; or beyond the thresholds established for use of this Certification without written authorization. [15A NCAC 02H .0501 and .0502]

No removal of vegetation or other impacts of any kind shall occur to state regulated riparian buffers beyond the footprint of impacts approved in a Buffer Authorization or Variance or as listed as an exempt activity in the applicable riparian buffer rules. [15A NCAC 02B .0200]

3. In accordance with 15A NCAC 02H .0506(h) and Session Law 2017-10, compensatory mitigation may be required for losses of greater than 300 linear feet of perennial streams and/or greater than one (1) acre of wetlands. Impacts associated with the removal of a dam shall not require mitigation when the removal complies with the requirements of Part 3 of Article 21 in Chapter 143 of the North Carolina General Statutes. Impacts to isolated and other non-404 jurisdictional wetlands shall not be combined with 404 jurisdictional wetlands for the purpose of determining when impact thresholds trigger a mitigation requirement. For linear publicly owned and maintained transportation projects that are not determined to be part of a larger common plan of development by the US Army Corps of Engineers, compensatory mitigation may be required for losses of greater than 300 linear feet per perennial stream.

GC4135

Compensatory stream and/or wetland mitigation shall be proposed and completed in compliance with G.S. 143-214.11. For applicants proposing to conduct mitigation within a project site, a complete mitigation proposal developed in accordance with the most recent guidance issued by the US Army Corps of Engineers Wilmington District shall be submitted for review and approval with the application for impacts.

4. All activities shall be in compliance with any applicable State Regulated Riparian Buffer Rules in Chapter 2 of Title 15A.
5. When applicable, all construction activities shall be performed and maintained in full compliance with G.S. Chapter 113A Article 4 (Sediment and Pollution Control Act of 1973). Regardless of applicability of the Sediment and Pollution Control Act, all projects shall incorporate appropriate Best Management Practices for the control of sediment and erosion so that no violations of state water quality standards, statutes, or rules occur. [15A NCAC 02H .0506(b)(3) and (c)(3) and 15A NCAC 02B .0200]

Design, installation, operation, and maintenance of all sediment and erosion control measures shall be equal to or exceed the requirements specified in the most recent version of the *North Carolina Sediment and Erosion Control Manual*, or for linear transportation projects, the *NC DOT Sediment and Erosion Control Manual*.

All devices shall be maintained on all construction sites, borrow sites, and waste pile (spoil) sites, including contractor-owned or leased borrow pits associated with the project. Sufficient materials required for stabilization and/or repair of erosion control measures and stormwater routing and treatment shall be on site at all times.

For borrow pit sites, the erosion and sediment control measures shall be designed, installed, operated, and maintained in accordance with the most recent version of the *North Carolina Surface Mining Manual*. Reclamation measures and implementation shall comply with the reclamation in accordance with the requirements of the Sedimentation Pollution Control Act and the Mining Act of 1971.

If the project occurs in waters or watersheds classified as Primary Nursery Areas (PNAs), SA, WS-I, WS-II, High Quality Waters (HQW), or Outstanding Resource Waters (ORW), then the sedimentation and erosion control designs shall comply with the requirements set forth in 15A NCAC 04B .0124, *Design Standards in Sensitive Watersheds*.

6. Sediment and erosion control measures shall not be placed in wetlands or waters except within the footprint of temporary or permanent impacts authorized under this Certification. Exceptions to this condition require application to and written approval from DWR. [15A NCAC 02H .0501 and .0502]
7. Erosion control matting that incorporates plastic mesh and/or plastic twine shall not be used along streambanks or within wetlands. Exceptions to this condition require application to and written approval from DWR. [15A NCAC 02B .0201]

GC4135

8. An NPDES Construction Stormwater Permit (NCG010000) is required for construction projects that disturb one (1) or more acres of land. The NCG010000 Permit allows stormwater to be discharged during land disturbing construction activities as stipulated in the conditions of the permit. If the project is covered by this permit, full compliance with permit conditions including the erosion & sedimentation control plan, inspections and maintenance, self-monitoring, record keeping and reporting requirements is required. [15A NCAC 02H .0506(b)(5) and (c)(5)]

The North Carolina Department of Transportation (NCDOT) shall be required to be in full compliance with the conditions related to construction activities within the most recent version of their individual NPDES (NCS000250) stormwater permit. [15A NCAC 02H .0506(b)(5) and (c)(5)]

9. All work in or adjacent to streams shall be conducted so that the flowing stream does not come in contact with the disturbed area. Approved best management practices from the most current version of the *NC Sediment and Erosion Control Manual*, or the *NC DOT Construction and Maintenance Activities Manual*, such as sandbags, rock berms, cofferdams, and other diversion structures shall be used to minimize excavation in flowing water. Exceptions to this condition require application to and written approval from DWR. [15A NCAC 02H .0506(b)(3) and (c)(3)]
10. If activities must occur during periods of high biological activity (e.g. sea turtle nesting, fish spawning, or bird nesting), then biological monitoring may be required at the request of other state or federal agencies and coordinated with these activities. [15A NCAC 02H .0506 (b)(2) and 15A NCAC 04B .0125]

All moratoriums on construction activities established by the NC Wildlife Resources Commission (WRC), US Fish and Wildlife Service (USFWS), NC Division of Marine Fisheries (DMF), or National Marine Fisheries Service (NMFS) shall be implemented. Exceptions to this condition require written approval by the resource agency responsible for the given moratorium. A copy of the approval from the resource agency shall be forwarded to DWR.

Work within a designated trout watershed of North Carolina (as identified by the Wilmington District of the US Army Corps of Engineers), or identified state or federal endangered or threatened species habitat, shall be coordinated with the appropriate WRC, USFWS, NMFS, and/or DMF personnel.

11. Culverts shall be designed and installed in such a manner that the original stream profiles are not altered and allow for aquatic life movement during low flows. The dimension, pattern, and profile of the stream above and below a pipe or culvert shall not be modified by widening the stream channel or by reducing the depth of the stream in connection with the construction activity. The width, height, and gradient of a proposed culvert shall be such as to pass the average historical low flow and spring flow without adversely altering flow velocity. [15A NCAC 02H .0506(b)(2) and (c)(2)]

GC4135

Placement of culverts and other structures in streams shall be below the elevation of the streambed by one foot for all culverts with a diameter greater than 48 inches, and 20% of the culvert diameter for culverts having a diameter less than or equal to 48 inches, to allow low flow passage of water and aquatic life.

If multiple pipes or barrels are required, they shall be designed to mimic the existing stream cross section as closely as possible including pipes or barrels at flood plain elevation and/or sills where appropriate. Widening the stream channel shall be avoided.

When topographic constraints indicate culvert slopes of greater than 5%, culvert burial is not required, provided that all alternative options for flattening the slope have been investigated and aquatic life movement/connectivity has been provided when possible (e.g. rock ladders, cross vanes, etc.). Notification, including supporting documentation to include a location map of the culvert, culvert profile drawings, and slope calculations, shall be provided to DWR 60 calendar days prior to the installation of the culvert.

When bedrock is present in culvert locations, culvert burial is not required provided that there is sufficient documentation of the presence of bedrock. Notification, including supporting documentation such as, a location map of the culvert, geotechnical reports, photographs, etc. shall be provided to DWR a minimum of 60 calendar days prior to the installation of the culvert. If bedrock is discovered during construction, then DWR shall be notified by phone or email within 24 hours of discovery.

If other site-specific topographic constraints preclude the ability to bury the culverts as described above and/or it can be demonstrated that burying the culvert would result in destabilization of the channel, then exceptions to this condition require application to and written approval from DWR.

Installation of culverts in wetlands shall ensure continuity of water movement and be designed to adequately accommodate high water or flood conditions. When roadways, causeways, or other fill projects are constructed across FEMA-designated floodways or wetlands, openings such as culverts or bridges shall be provided to maintain the natural hydrology of the system as well as prevent constriction of the floodway that may result in destabilization of streams or wetlands.

The establishment of native woody vegetation and other soft stream bank stabilization techniques shall be used where practicable instead of rip-rap or other bank hardening methods.

12. Bridge deck drains shall not discharge directly into the stream. Stormwater shall be directed across the bridge and pre-treated through site-appropriate means to the maximum extent practicable (e.g. grassed swales, pre-formed scour holes, vegetated buffers, etc.) before entering the stream. Exceptions to this condition require application to and written approval from DWR. [15A NCAC 02H .0506(b)(5)]

GC4135

13. Application of fertilizer to establish planted/seeded vegetation within disturbed riparian areas and/or wetlands shall be conducted at agronomic rates and shall comply with all other Federal, State and Local regulations. Fertilizer application shall be accomplished in a manner that minimizes the risk of contact between the fertilizer and surface waters. [15A NCAC 02B .0200 and 15A NCAC 02B .0231]
14. If concrete is used during construction, then all necessary measures shall be taken to prevent direct contact between uncured or curing concrete and waters of the state. Water that inadvertently contacts uncured concrete shall not be discharged to waters of the state. [15A NCAC 02B .0200]
15. All proposed and approved temporary fill and culverts shall be removed and the impacted area shall be returned to natural conditions within 60 calendar days after the temporary impact is no longer necessary. The impacted areas shall be restored to original grade, including each stream's original cross sectional dimensions, planform pattern, and longitudinal bed profile. For projects that receive written approval, no temporary impacts are allowed beyond those included in the application and authorization. All temporarily impacted sites shall be restored and stabilized with native vegetation. [15A NCAC 02H .0506(b)(2) and (c)(2)]
16. All proposed and approved temporary pipes/culverts/rip-rap pads etc. in streams shall be installed as outlined in the most recent edition of the *North Carolina Sediment and Erosion Control Planning and Design Manual* or the *North Carolina Surface Mining Manual* or the *North Carolina Department of Transportation Best Management Practices for Construction and Maintenance Activities* so as not to restrict stream flow or cause dis-equilibrium during use of this Certification. [15A NCAC 02H .0506(b)(2) and (c)(2)]
17. Any rip-rap required for proper culvert placement, stream stabilization, or restoration of temporarily disturbed areas shall be restricted to the area directly impacted by the approved construction activity. All rip-rap shall be placed such that the original stream elevation and streambank contours are restored and maintained. Placement of rip-rap or other approved materials shall not result in de-stabilization of the stream bed or banks upstream or downstream of the area or in a manner that precludes aquatic life passage. [15A NCAC 02H .0506(b)(2)]
18. Any rip-rap used for stream or shoreline stabilization shall be of a size and density to prevent movement by wave, current action, or stream flows and shall consist of clean rock or masonry material free of debris or toxic pollutants. Rip-rap shall not be installed in the streambed except in specific areas required for velocity control and to ensure structural integrity of bank stabilization measures. [15A NCAC 02H .0506(b)(2)]
19. Applications for rip-rap groins proposed in accordance with 15A NCAC 07H .1401 (NC Division of Coastal Management General Permit for construction of Wooden and Rip-rap Groins in Estuarine and Public Trust Waters) shall meet all the specific conditions for design and construction specified in 15A NCAC 07H .1405.

GC4135

20. All mechanized equipment operated near surface waters shall be inspected and maintained regularly to prevent contamination of surface waters from fuels, lubricants, hydraulic fluids, or other toxic materials. Construction shall be staged in order to minimize the exposure of equipment to surface waters to the maximum extent practicable. Fueling, lubrication and general equipment maintenance shall be performed in a manner to prevent, to the maximum extent practicable, contamination of surface waters by fuels and oils. [15A NCAC 02H .0506(b)(3) and (c)(3) and 15A NCAC 02B .0211 (12)]
21. Heavy equipment working in wetlands shall be placed on mats or other measures shall be taken to minimize soil disturbance. [15A NCAC 02H .0506(b)(3) and (c)(3)]
22. In accordance with 143-215.85(b), the applicant shall report any petroleum spill of 25 gallons or more; any spill regardless of amount that causes a sheen on surface waters; any petroleum spill regardless of amount occurring within 100 feet of surface waters; and any petroleum spill less than 25 gallons that cannot be cleaned up within 24 hours.
23. If an environmental document is required under the State Environmental Policy Act (SEPA), then this General Certification is not valid until a Finding of No Significant Impact (FONSI) or Record of Decision (ROD) is issued by the State Clearinghouse. If an environmental document is required under the National Environmental Policy Act (NEPA), then this General Certification is not valid until a Categorical Exclusion, the Final Environmental Assessment, or Final Environmental Impact Statement is published by the lead agency. [15A NCAC 01C .0107(a)]
24. This General Certification does not relieve the applicant of the responsibility to obtain all other required Federal, State, or Local approvals before proceeding with the project, including those required by, but not limited to, Sediment and Erosion Control, Non-Discharge, Water Supply Watershed, and Trout Buffer regulations.
25. The applicant and their authorized agents shall conduct all activities in a manner consistent with State water quality standards (including any requirements resulting from compliance with §303(d) of the Clean Water Act), and any other appropriate requirements of State and Federal Law. If DWR determines that such standards or laws are not being met, including failure to sustain a designated or achieved use, or that State or Federal law is being violated, or that further conditions are necessary to assure compliance, then DWR may revoke or modify a written authorization associated with this General Water Quality Certification. [15A NCAC 02H .0507(d)]
26. The permittee shall require its contractors and/or agents to comply with the terms and conditions of this permit in the construction and maintenance of this project, and shall provide each of its contractors and/or agents associated with the construction or maintenance of this project with a copy of this Certification. A copy of this Certification, including all conditions shall be available at the project site during the construction and maintenance of this project. [15A NCAC 02H .0507 (c) and 15A NCAC 02H .0506 (b)(2) and (c)(2)]

GC4135

27. When written authorization is required for use of this Certification, upon completion of all permitted impacts included within the approval and any subsequent modifications, the applicant shall be required to return a certificate of completion (available on the DWR website <https://edocs.deq.nc.gov/Forms/Certificate-of-Completion>). [15A NCAC 02H .0502(f)]
28. Additional site-specific conditions, including monitoring and/or modeling requirements, may be added to the written approval letter for projects proposed under this Water Quality Certification in order to ensure compliance with all applicable water quality and effluent standards. [15A NCAC 02H .0507(c)]
29. If the property or project is sold or transferred, the new permittee shall be given a copy of this Certification (and written authorization if applicable) and is responsible for complying with all conditions. [15A NCAC 02H .0501 and .0502]

III. GENERAL CERTIFICATION ADMINISTRATION:

1. In accordance with North Carolina General Statute 143-215.3D(e), written approval for a 401 Water Quality General Certification must include the appropriate fee. An applicant for a CAMA permit under Article 7 of Chapter 113A of the General Statutes for which a Water Quality Certification is required shall only make one payment to satisfy both agencies; the fee shall be as established by the Secretary in accordance with 143-215.3D(e)(7).
2. This Certification neither grants nor affirms any property right, license, or privilege in any waters, or any right of use in any waters. This Certification does not authorize any person to interfere with the riparian rights, littoral rights, or water use rights of any other person and this Certification does not create any prescriptive right or any right of priority regarding any usage of water. This Certification shall not be interposed as a defense in any action respecting the determination of riparian or littoral rights or other rights to water use. No consumptive user is deemed by virtue of this Certification to possess any prescriptive or other right of priority with respect to any other consumptive user regardless of the quantity of the withdrawal or the date on which the withdrawal was initiated or expanded.
3. This Certification grants permission to the Director, an authorized representative of the Director, or DWR staff, upon the presentation of proper credentials, to enter the property during normal business hours. [15A NCAC 02H .0502(e)]
4. This General Certification shall expire on the same day as the expiration date of the corresponding Nationwide Permit and/or Regional General Permit. The conditions in effect on the date of issuance of Certification for a specific project shall remain in effect for the life of the project, regardless of the expiration date of this Certification. This General Certification is rescinded when the US Army Corps of Engineers reauthorizes any of the corresponding Nationwide Permits and/or Regional General Permits or when deemed appropriate by the Director of the Division of Water Resources.

GC4135

5. Non-compliance with or violation of the conditions herein set forth by a specific project may result in revocation of this General Certification for the project and may also result in criminal and/or civil penalties.
6. The Director of the North Carolina Division of Water Resources may require submission of a formal application for Individual Certification for any project in this category of activity if it is deemed in the public's best interest or determined that the project is likely to have a significant adverse effect upon water quality, including state or federally listed endangered or threatened aquatic species, or degrade the waters so that existing uses of the water or downstream waters are precluded.

History Note: Water Quality Certification (WQC) Number 4135 issued December 1, 2017 replaces WQC Number 4088 issued March 3, 2017; WQC 3886 issued March 12, 2012; WQC Number 3820 issued April 6, 2010; WQC Number 3627 issued March 2007; WQC Number 3404 issued March 2003; WQC Number 3375 issued March 18, 2002; WQC Number 3289 issued June 1, 2000; WQC Number 3103 issued February 11, 1997; WQC Number 2732 issued May 1, 1992; WQC Number 2666 issued January 21, 1992; WQC Number 2177 issued November 5, 1987.

REVISIONS

--	--

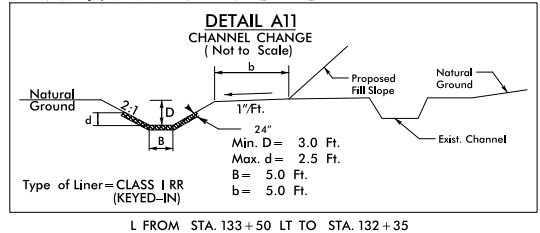
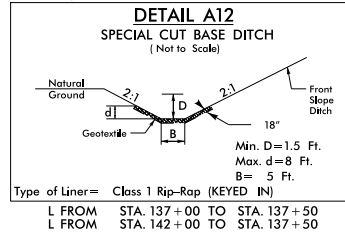
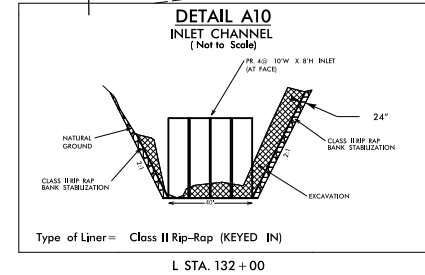
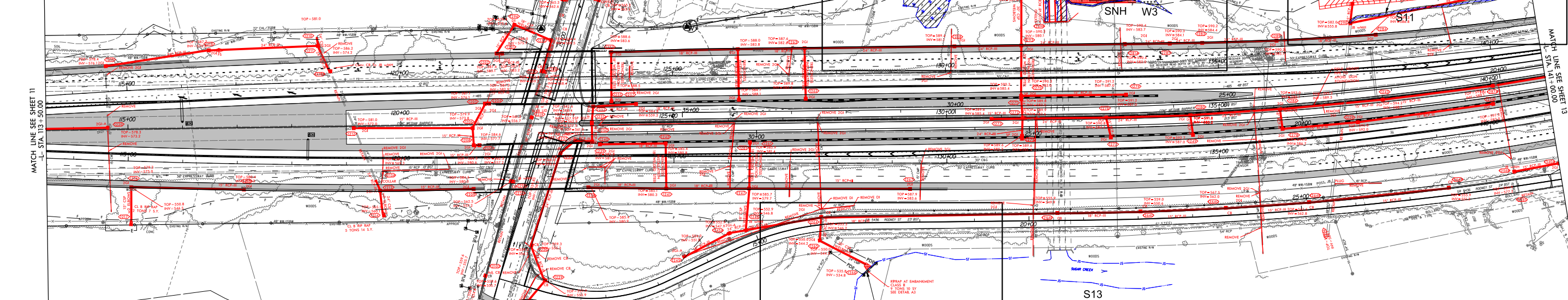
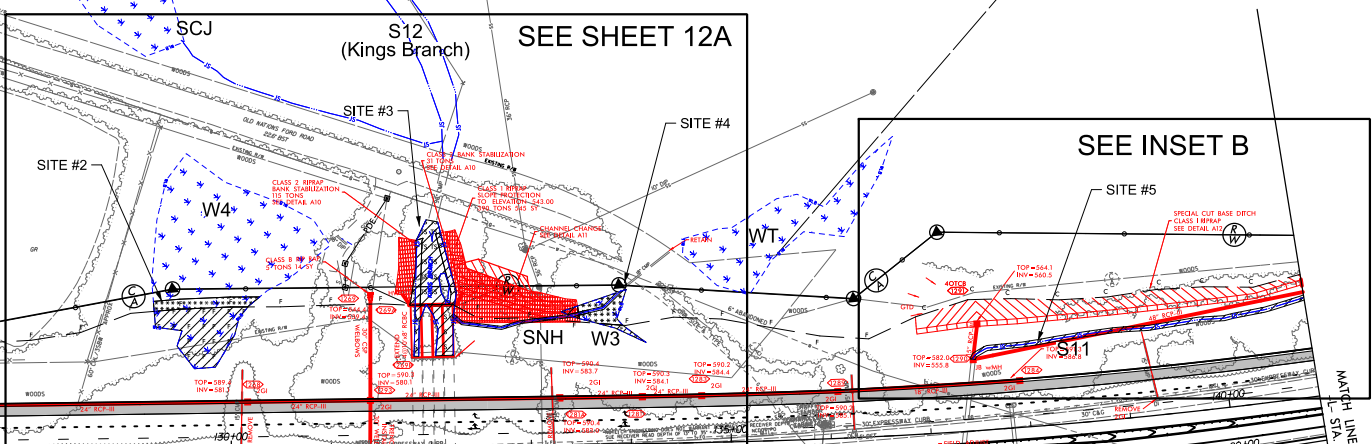
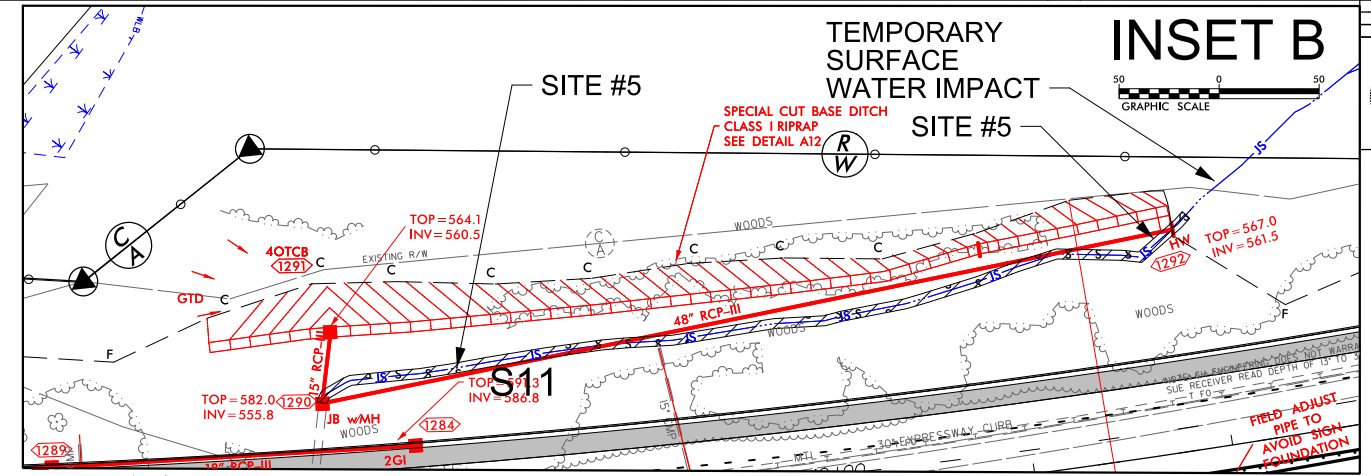
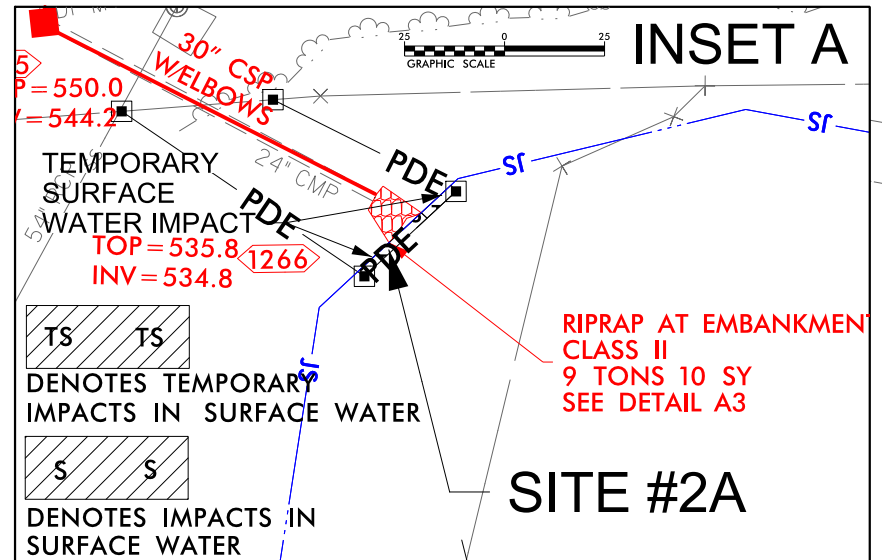
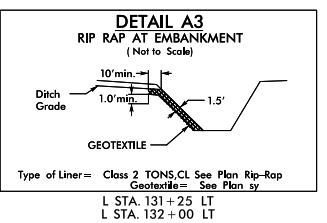

SITE #3 AND SITE #5 NOTE:
 THE EXISTING CULVERT IS NOT BURIED, THEREFORE THE CULVERT EXTENSION WILL NOT BE BURIED. THE BOTTOM ELEVATION OF THE EXTENDED CULVERT WILL MATCH THE ELEVATION OF THE EXISTING STREAM BED.

- DENOTES TEMPORARY IMPACTS IN SURFACE WATER
- DENOTES IMPACTS IN SURFACE WATER
- DENOTES MECHANIZED CLEARING
- DENOTES FILL IN WETLAND

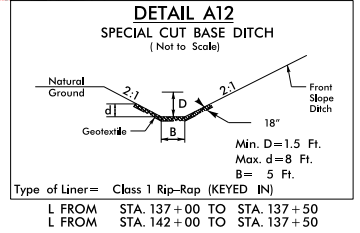
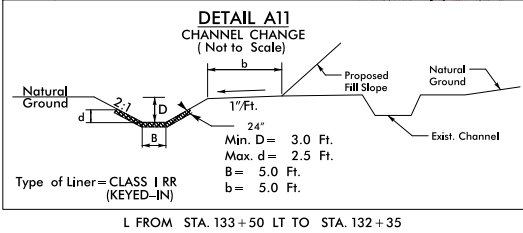
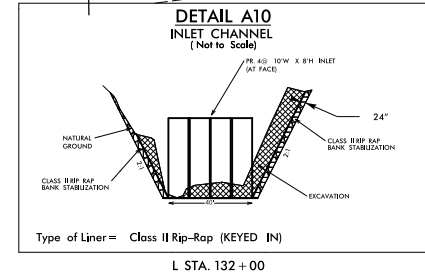
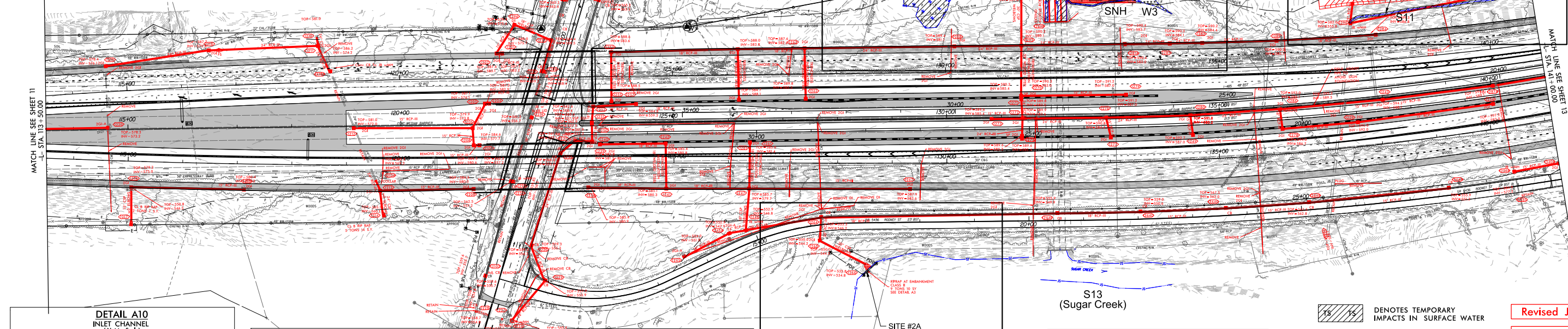
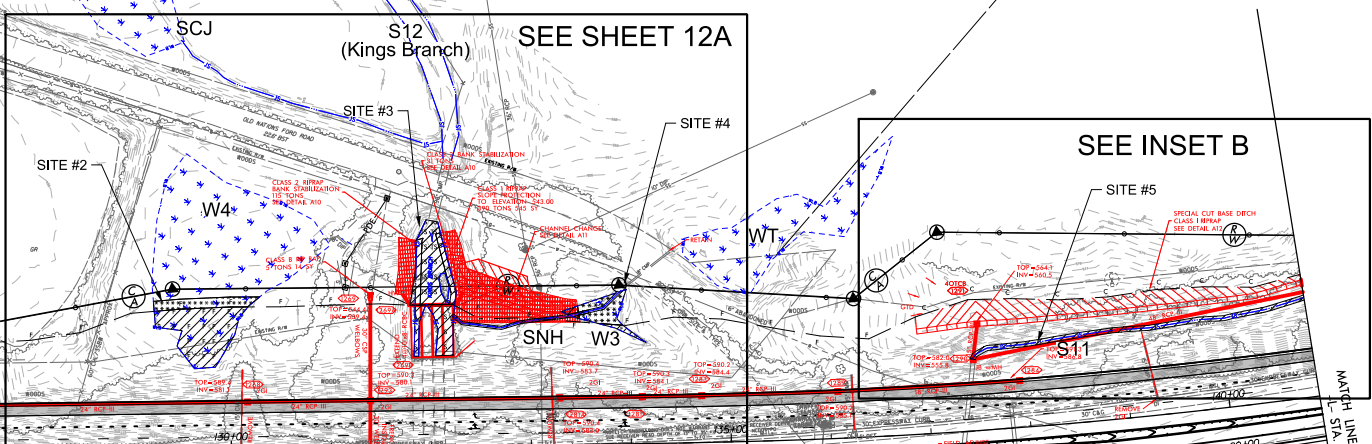
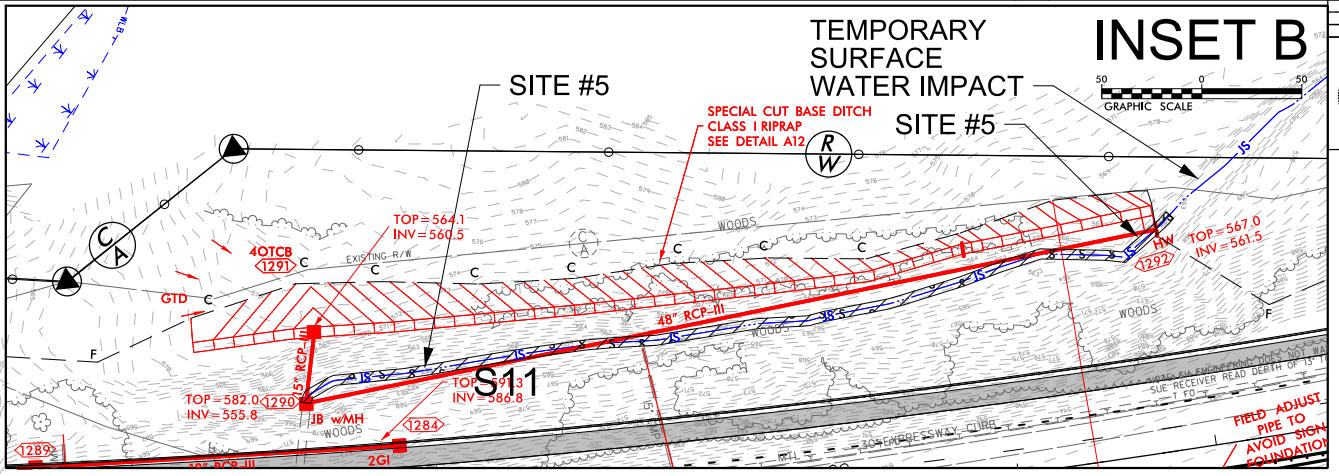
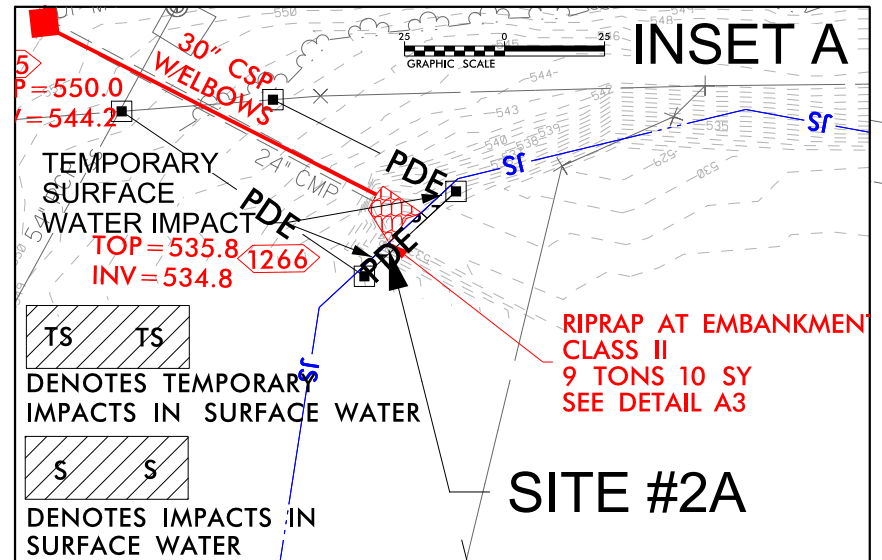
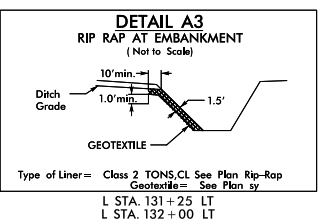

SITE #3 AND SITE #5 NOTE:
THE EXISTING CULVERT IS NOT BURIED, THEREFORE THE CULVERT EXTENSION WILL NOT BE BURIED. THE BOTTOM ELEVATION OF THE EXTENDED CULVERT WILL MATCH THE ELEVATION OF THE EXISTING STREAM BED.

- DENOTES TEMPORARY IMPACTS IN SURFACE WATER
- DENOTES IMPACTS IN SURFACE WATER
- DENOTES MECHANIZED CLEARING
- DENOTES FILL IN WETLAND

Revised July 2020

PERMIT DRAWING
SHEET 11 OF 115

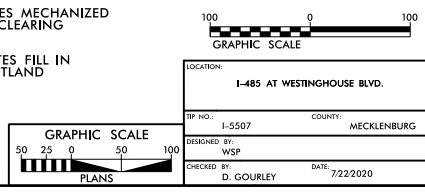

8/17/99

DETAIL A10 INLET CHANNEL (Not to Scale)

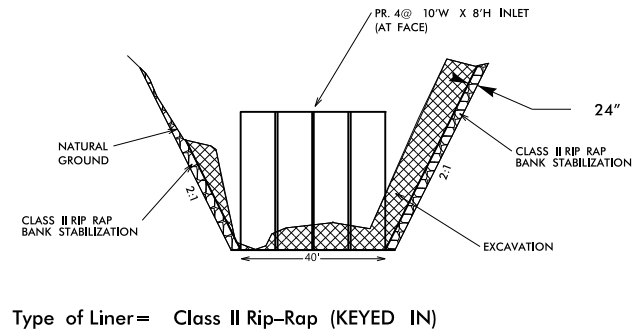

Type of Liner = Class II Rip-Rap (KEYED IN)

SITE #3 NOTE:
THE EXISTING CULVERT IS NOT BURIED, THEREFORE THE CULVERT EXTENSION WILL NOT BE BURIED. THE BOTTOM ELEVATION OF THE EXTENDED CULVERT WILL MATCH THE ELEVATION OF THE EXISTING STREAM BED.

DETAIL A11 CHANNEL CHANGE (Not to Scale)

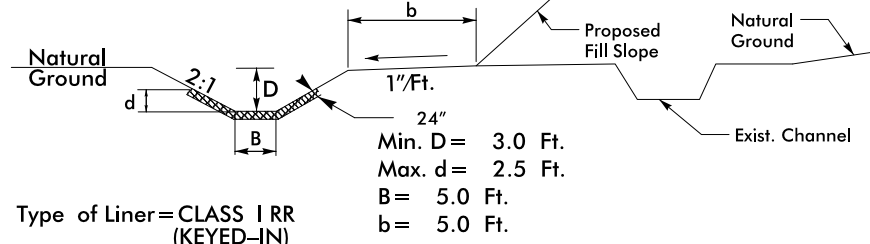

L FROM STA. 133+50 LT TO STA. 132+35

wsp
1001 Morehead Square Dr.
Suite 610
Charlotte NC, 28203
NC LIC NO. F-0165

PROJECT REFERENCE NO. I-5507	SHEET NO. 12A
ROADWAY DESIGN ENGINEER	HYDRAULICS ENGINEER



S12 (Kings Branch)

SITE #3

SITE #4

SITE #2

W4

WT

SNH

W3

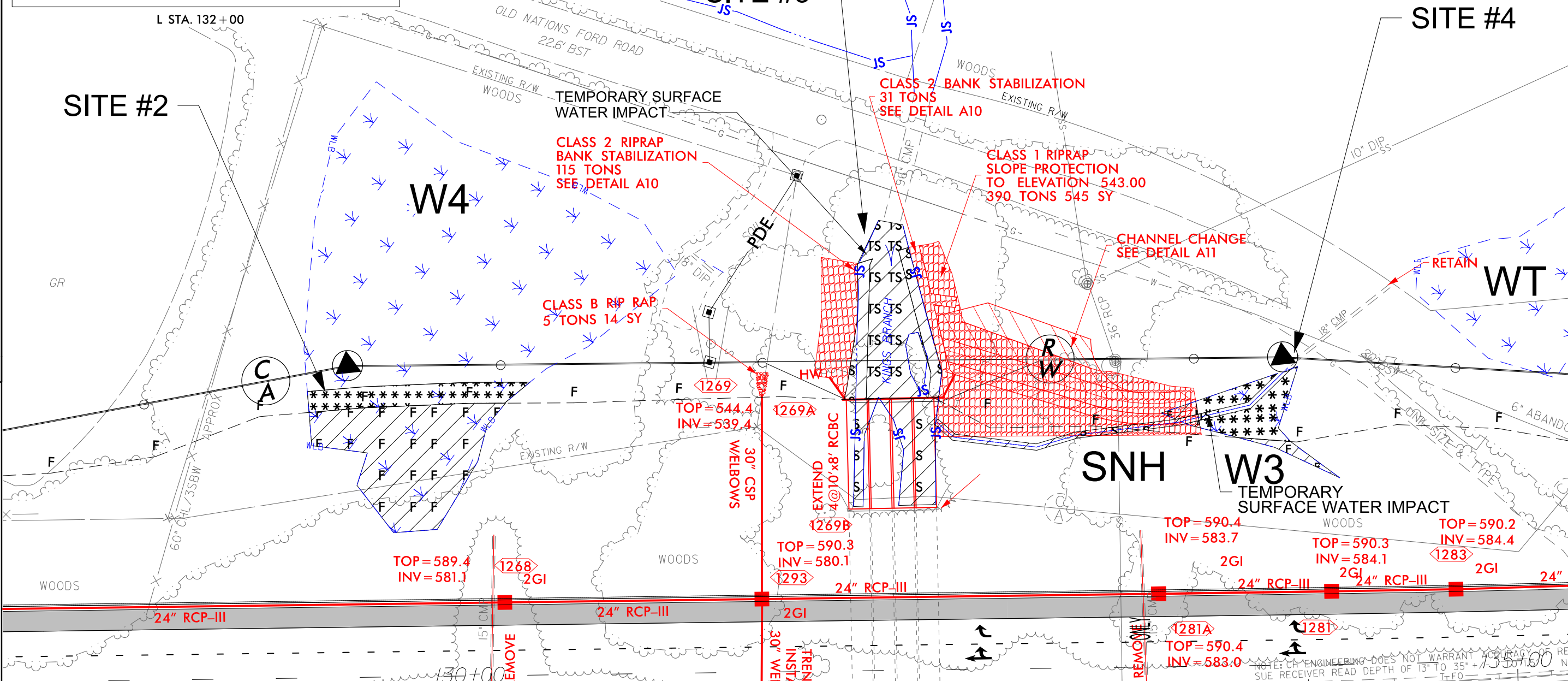

DENOTES FILL IN WETLAND



DENOTES MECHANIZED CLEARING



DENOTES IMPACTS IN SURFACE WATER



DENOTES TEMPORARY IMPACTS IN SURFACE WATER



Revised July 2020

PERMIT DRAWING SHEET 12 OF 115

7/22/2020
 P:\DWG\15021\15507_Hyd.prm_wet_psh12A.dgn
 P:\DWG\15021\15507_Hyd.prm_wet_psh12A.dgn
 P:\DWG\15021\15507_Hyd.prm_wet_psh12A.dgn

8/17/99

DETAIL A10 INLET CHANNEL (Not to Scale)

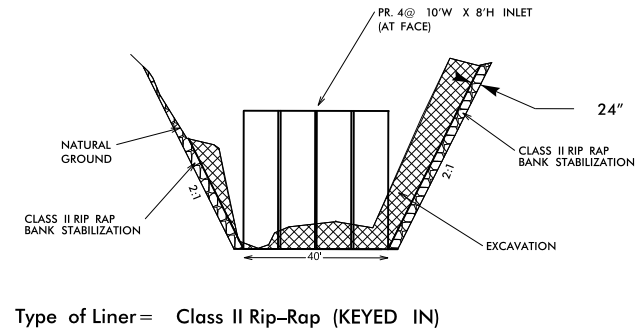

SITE #3 NOTE:
THE EXISTING CULVERT IS NOT BURIED, THEREFORE THE CULVERT EXTENSION WILL NOT BE BURIED. THE BOTTOM ELEVATION OF THE EXTENDED CULVERT WILL MATCH THE ELEVATION OF THE EXISTING STREAM BED.

DETAIL A11 CHANNEL CHANGE (Not to Scale)

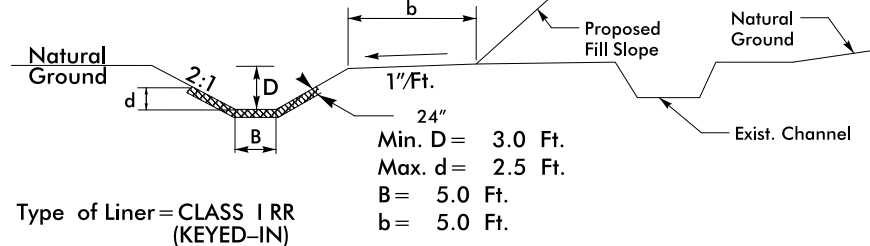

PROJECT REFERENCE NO. I-5507	SHEET NO. 12A
ROADWAY DESIGN ENGINEER	HYDRAULICS ENGINEER

BLYTHE

S12 (Kings Branch)

SITE #3

L FROM STA. 133+50 LT TO STA. 132+35

SITE #4

SITE #2

W4

SNH

W3

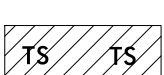
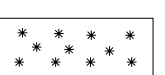
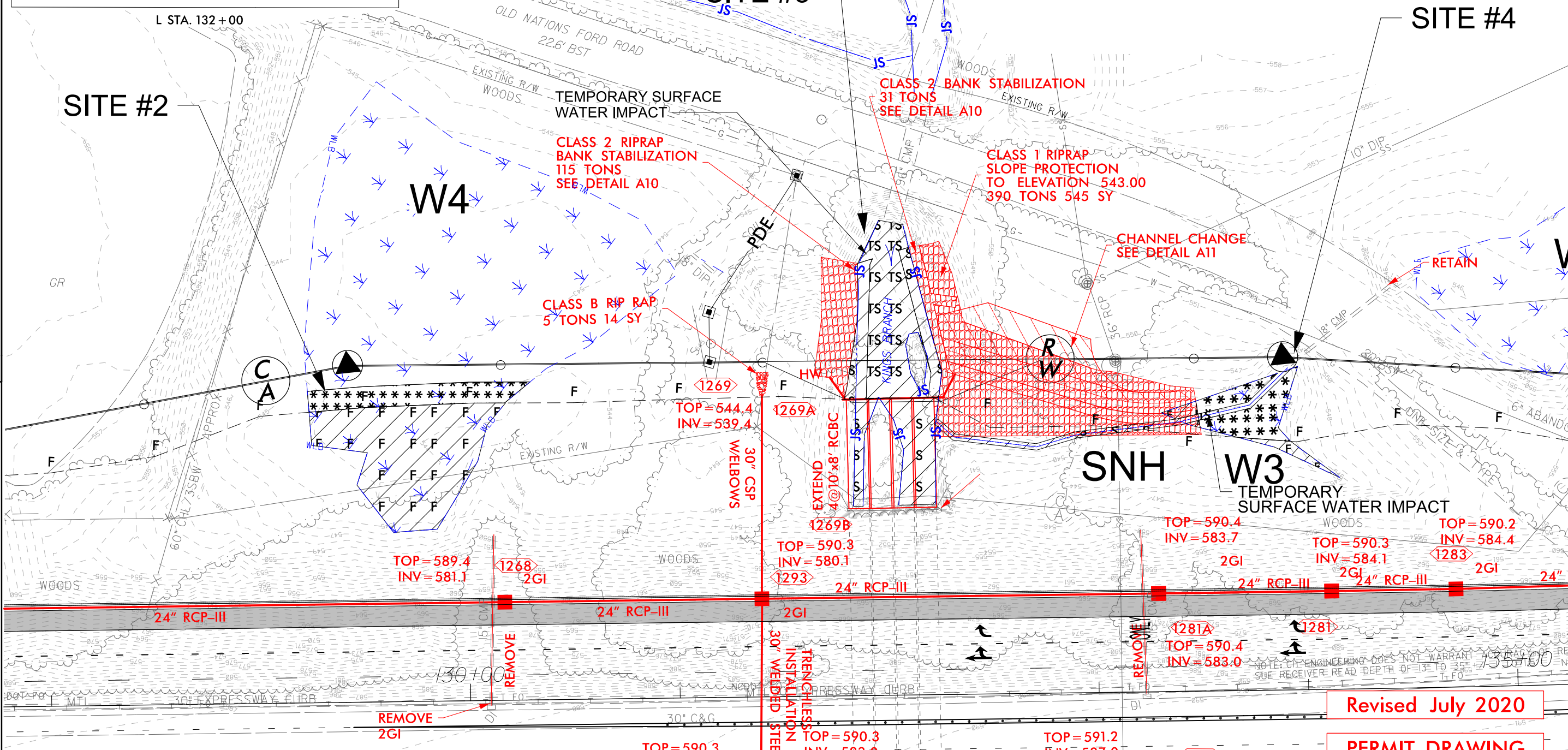

Revised July 2020

PERMIT DRAWING
SHEET 13 OF 115



7/22/2020
 C:\p\dw\lgs02\tes_wor\kingdir\9684_336401_5022\15507_Hyd_prm_wet_psh12A_cont.dgn
 P:\DWG\15507

6/23/16



PROJ. REFERENCE NO.	SHEET NO.
I-5507	12-2

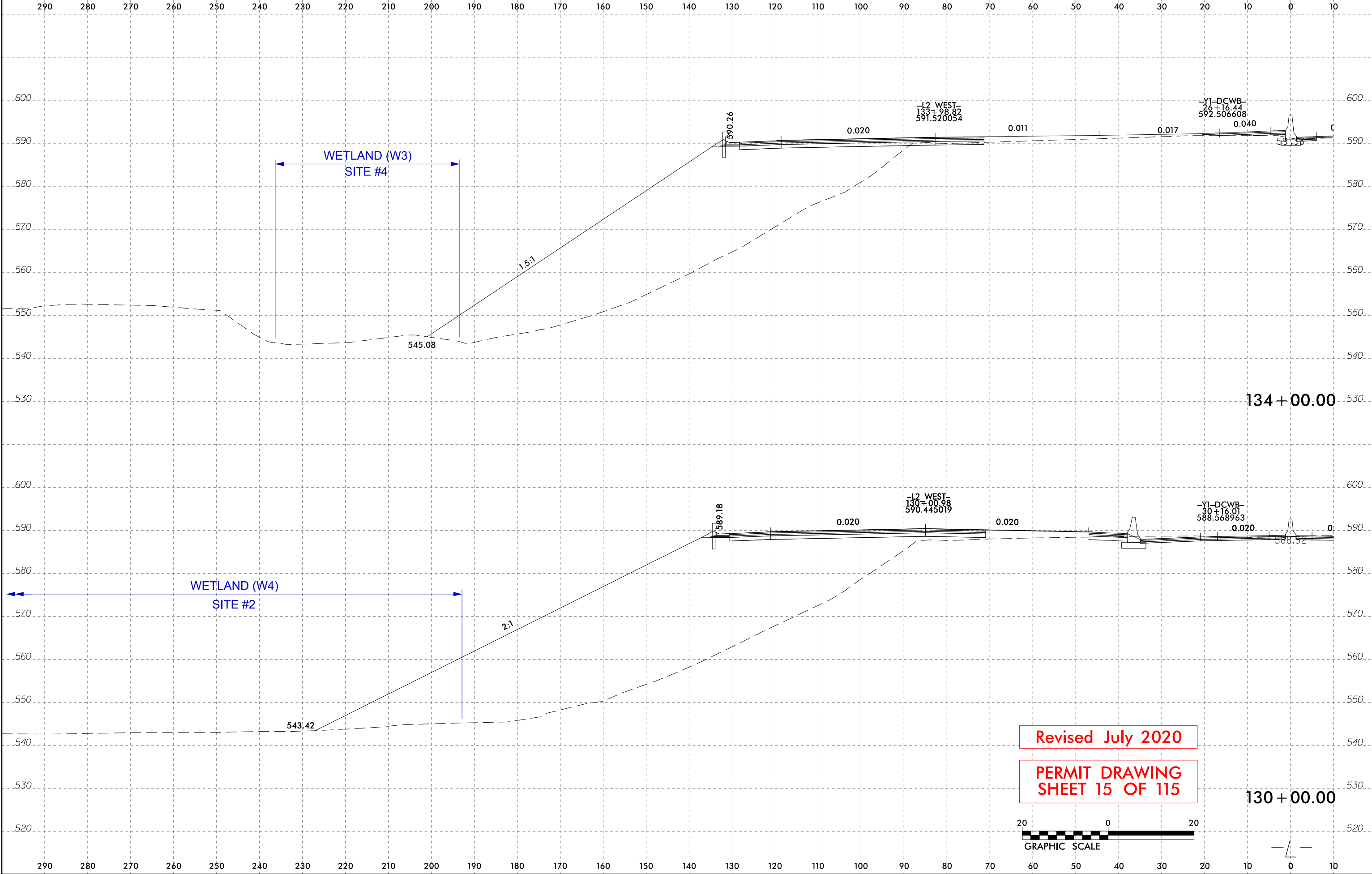

Revised July 2020

PERMIT DRAWING
SHEET 15 OF 115

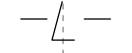
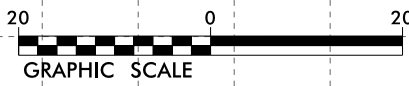

T:\2020\11\15\15507\15507_hyd.prm_wet_psh12.XS.dgn

8/17/99

wsp 1001 Morehead Square Dr.
Suite 610
Charlotte NC, 28203
NC LIC NO. F-0165

PROJECT REFERENCE NO. L-5507	SHEET NO. 13
RW SHEET NO.	HYDRAULICS ENGINEER
ROADWAY DESIGN ENGINEER	SEAL 032689 ENGINEER DAVID B. GOURLEY
	SEAL 041267 ENGINEER ANDREW M. MULLINS

BLYTHE

 DENOTES IMPACTS IN SURFACE WATER

 DENOTES TEMPORARY IMPACTS IN SURFACE WATER

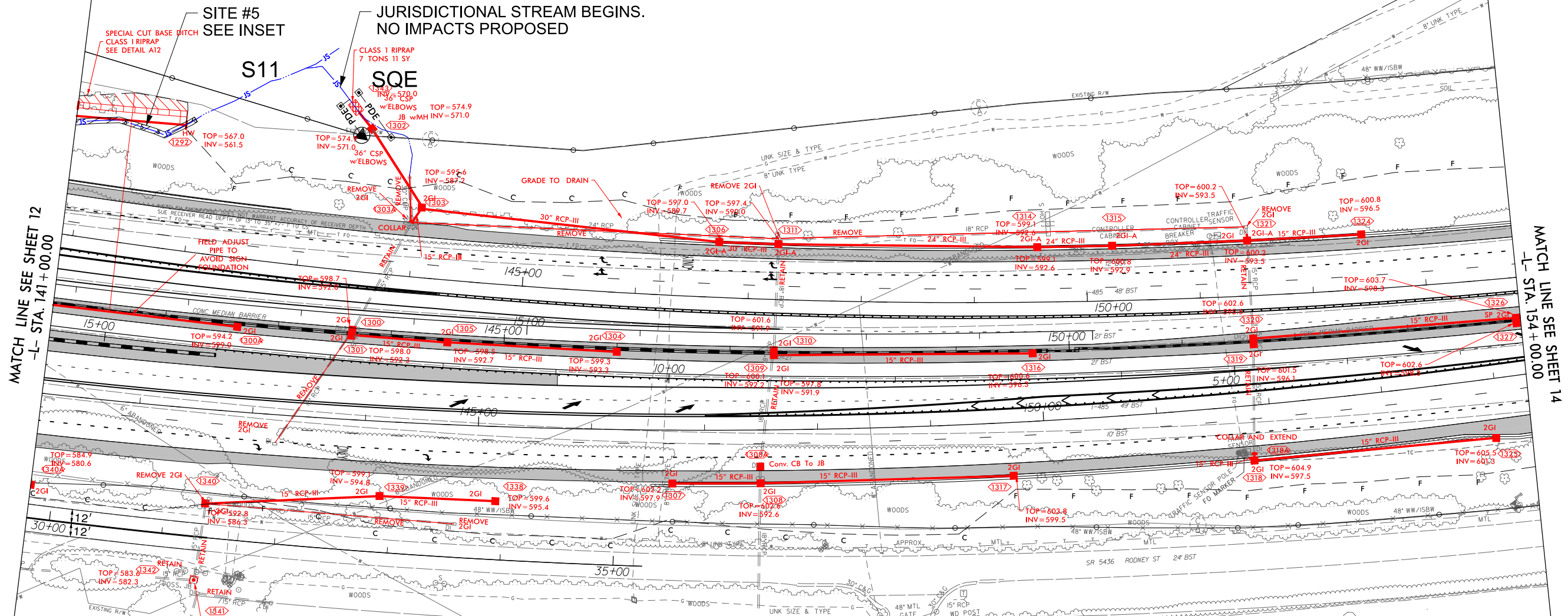
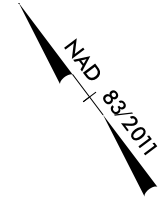
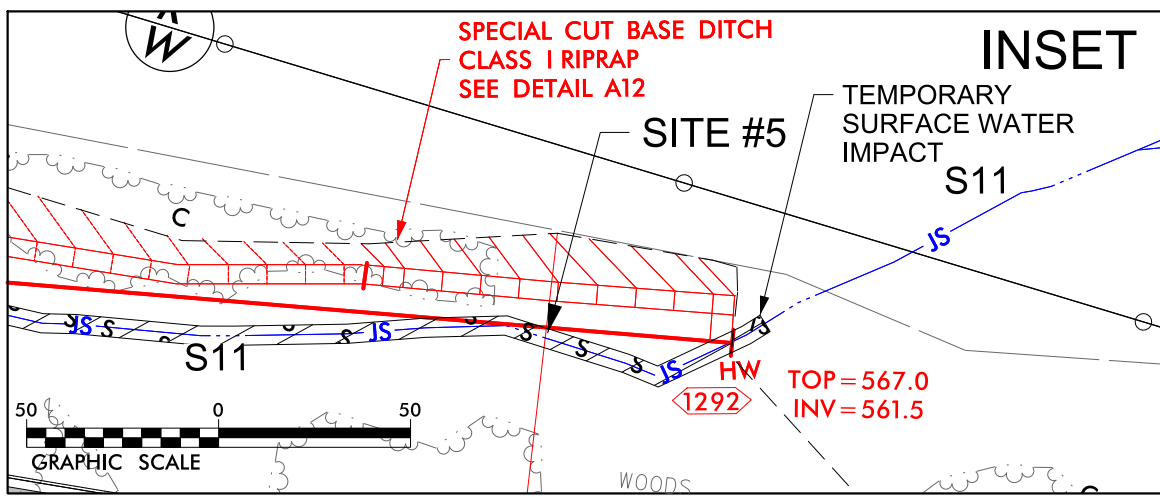

MATCH LINE SEE SHEET 12
-L- STA. 141+00.00

MATCH LINE SEE SHEET 14
-L- STA. 154+00.00

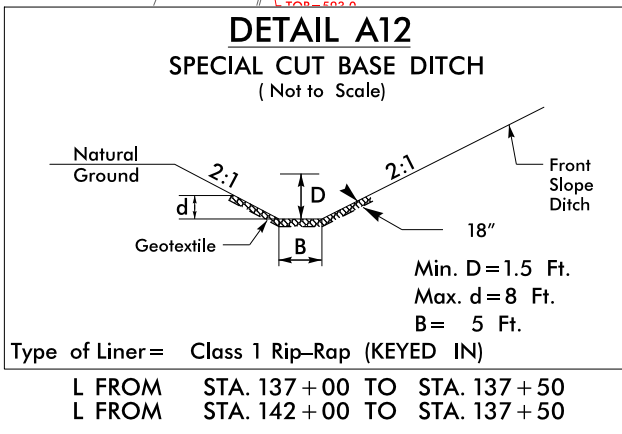

 DENOTES IMPACTS IN SURFACE WATER

 DENOTES TEMPORARY IMPACTS IN SURFACE WATER

Revised July 2020

PERMIT DRAWING SHEET 16 OF 115

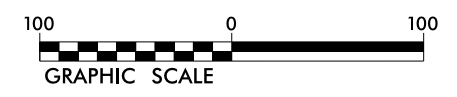

7/22/2020
S:\p\dw\lgs02\tcs_wor\kingdir\9684\336401_5023\5507_Hyd_prm_wet.psh13.dgn
END WIC5025

PROJECT REFERENCE NO. L-5507	SHEET NO. 13
ROADWAY DESIGN ENGINEER DAVID B. GOUDRY	HYDRAULICS ENGINEER ANDREW M. MULLINS
BLYTHE	

DENOTES IMPACTS IN SURFACE WATER

DENOTES TEMPORARY IMPACTS IN SURFACE WATER

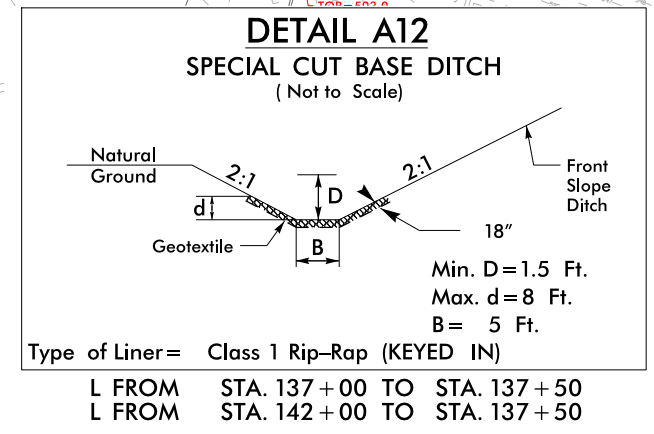
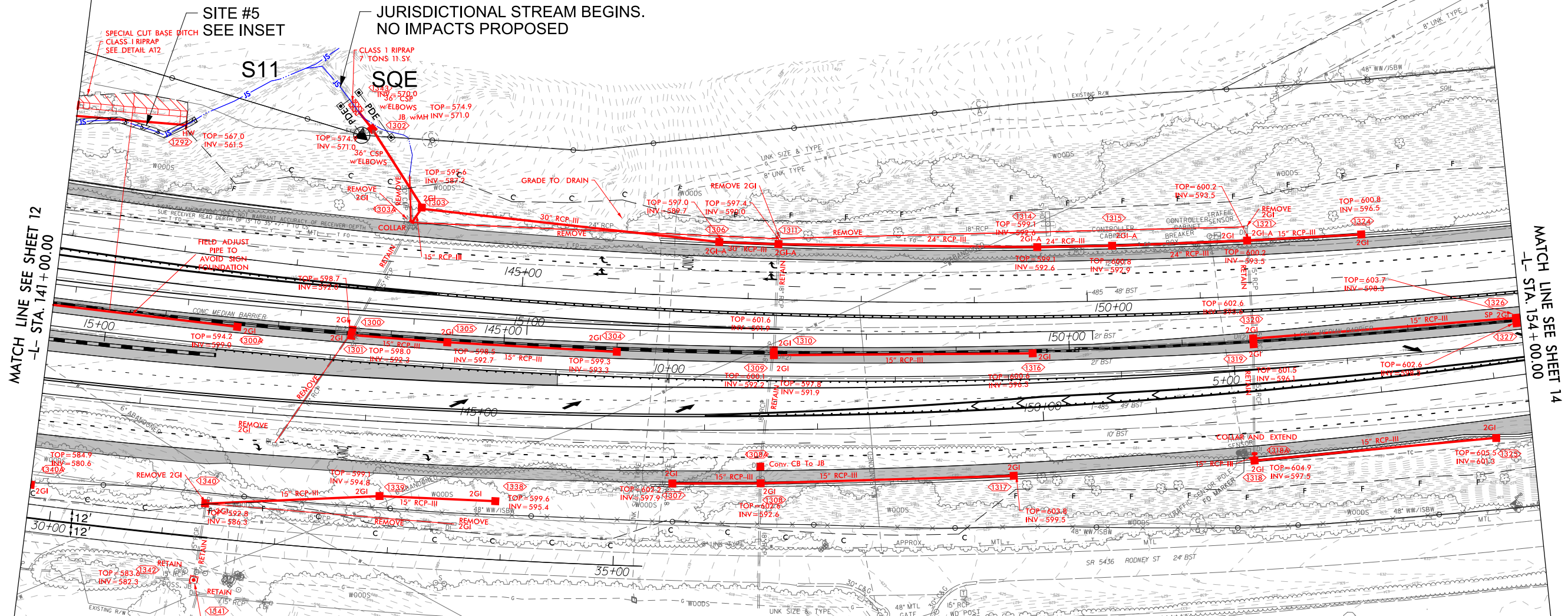
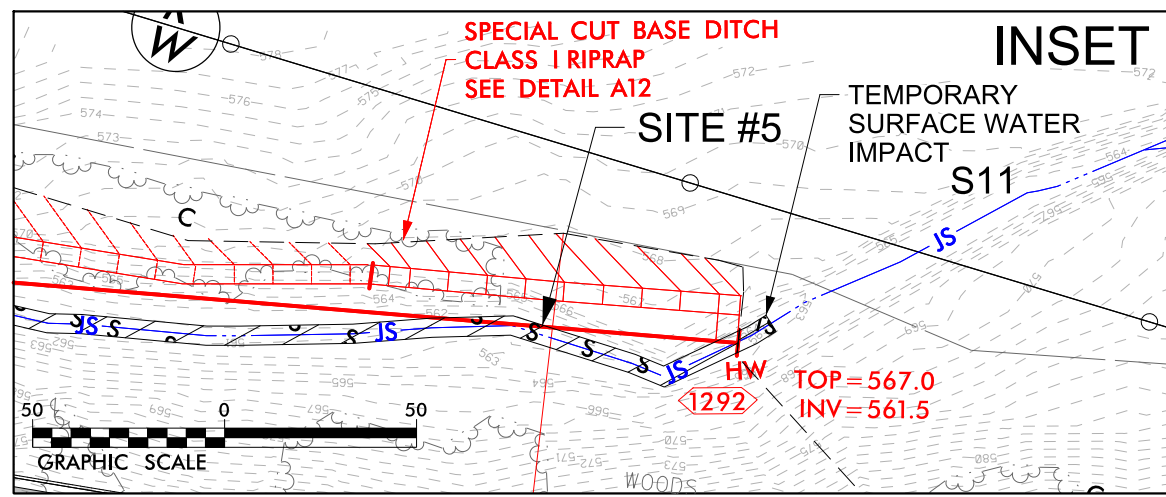

DENOTES IMPACTS IN SURFACE WATER

DENOTES TEMPORARY IMPACTS IN SURFACE WATER

Revised July 2020

PERMIT DRAWING
SHEET 17 OF 115

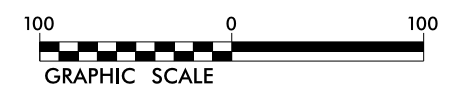

7/22/2020
P:\DWG\2020\tes_wor\kingdir\9684\336401_5024\L5507_Hyd_prm_wet.psh13_cont.dgn
P:\DWG\2020\tes_wor\kingdir\9684\336401_5024\L5507_Hyd_prm_wet.psh13_cont.dgn

WETLAND AND SURFACE WATER IMPACTS SUMMARY

Site No.	Station (From/To)	Structure Size / Type	WETLAND IMPACTS					SURFACE WATER IMPACTS				
			Permanent Fill In Wetlands (ac)	Temp. Fill In Wetlands (ac)	Excavation in Wetlands (ac)	Mechanized Clearing in Wetlands (ac)	Hand Clearing in Wetlands (ac)	Permanent SW impacts (ac)	Temp. SW impacts (ac)	Existing Channel Impacts Permanent (ft)	Existing Channel Impacts Temp. (ft)	Natural Stream Design (ft)
1	110+50 -L- RT	Extend Existing 48" RCP						< 0.01		28		
1	110+50 -L- RT	Bank Stabilization						< 0.01	< 0.01	18	13	
2	129+00 - 130+00 -L- LT	Roadway Fill	0.08			0.02						
2A	128+50 -L- RT	Bank Stabilization						< 0.01	< 0.01	11	20	
3	132+00 -L- LT	Extend 4 @ 10'x8' RCBC						0.03		52		
3	132+00 LT	Bank Stabilization						0.02	< 0.01	70	16	
3	132+00 LT	Culvert Construction Activities							0.03			
4	132+00 - 134+00 -L- LT	Roadway Fill	< 0.01			0.02		< 0.01		95		
4	132+00 - 134+00 -L- LT	Channel Change	< 0.01					< 0.01	< 0.01	35	10	
5	137+40 - 142+25 -L- LT	Extend 48" RCP with Junction Box						0.05	< 0.01	444	10	
6	293+50 -L-	Bank Stabilization						< 0.01	< 0.01	48	10	
7	294+00 - 301+00 -L- LT	Rock Plating							0.07		680	
8	298+00 -L- LT	Concrete Energy Dissipator						< 0.01		7		
8	298+00 -L- LT	Bank Stabilization						< 0.01		10		
9A	302+00 - 308+50 LT	Roadway Fill	0.05			0.05						
9B	309+50 -L- LT	Roadway Fill	0.07			0.07						
10	309+50 -L- LT	Bank Stabilization at Temp. Bridge						0.01	0.01	65		
11	343+00 -L-	Bank Stabilization at Temp. Bridge						0.03	0.05	157		
11	343+00 -L-	Drill Shaft Installation							0.05			
12	344+50 - 346+50 -L- RT	Roadway Fill	0.13			< 0.01						
13	360+00 -L- LT	Bank Stabilization						< 0.01	< 0.01	8	20	
13	360+00 -L- RT	Extend 3@ 9'x9' RCBC						0.01		49		
13	360+50 -L- RT	Bank Stabilization						< 0.01	< 0.01	38	20	
13	360+50 -L- RT	Culvert Construction Activities							< 0.01			
TOTALS*:			0.33			0.17		0.18	0.25	1135	799	0

*Rounded totals are sum of actual impacts

NOTES:

- At Sites 1, 3, 5, and 13, the existing culvert is not buried, therefore the culvert extension will not be buried. The bottom elevation of the extended culvert will match the elevation of the existing stream bed.
- At Site 1, <0.01 ac (18 lf) of temporary impacts due to construction activities are included within the bank stabilization impacts.
- At Site 3, 0.02 ac (70 lf) of temporary impacts due to construction activities are included within the bank stabilization impacts.
- At Site 10, <0.01 ac (30 lf) of temporary impacts due to the temporary bridge are included within the bank stabilization impacts.
- At Site 11, 0.03 ac (122 lf) of temporary impacts due to the temporary bridge and installation of the drilled shaft are included within the bank stabilization impacts.
- At Site 13, <0.01 ac (38 lf) of temporary impacts due to construction activities are included within the bank stabilization impacts.

NC DEPARTMENT OF TRANSPORTATION
 DIVISION OF HIGHWAYS
 07/20/20
 MECKLENBURG
 TIP NO. I-5507
 WBS NO. 43609.3.2

SHEET 112 OF 115

Revised July 2020

WETLAND AND SURFACE WATER IMPACTS SUMMARY

Site No.	Station (From/To)	Structure Size / Type	WETLAND IMPACTS					SURFACE WATER IMPACTS				
			Permanent Fill In Wetlands (ac)	Temp. Fill In Wetlands (ac)	Excavation in Wetlands (ac)	Mechanized Clearing in Wetlands (ac)	Hand Clearing in Wetlands (ac)	Permanent SW impacts (ac)	Temp. SW impacts (ac)	Existing Channel Impacts Permanent (ft)	Existing Channel Impacts Temp. (ft)	Natural Stream Design (ft)
42	894+00/895+70 -L-	Roadway Fill	0.03									
42	894+00/895+70 -L- RT	Extend 42" RCP						0.02		105		
42	894+00/895+70 -L- RT	Channel Change						< 0.01	< 0.01	20	12	
42	894+00/895+70 -L- LT	Bank Stabilization						< 0.01		20		
43	18+60 -Y19RPC- RT	Bank Stabilization						< 0.01	< 0.01	30	10	
44	28+50 -Y2-	Extend 3 @ 8'x9' RCBC						< 0.01		26		
44	28+50 -Y2-	Bank Stabilization						< 0.01	< 0.01	28	19	
44	28+50 -Y2-	Culvert Construction Activities							< 0.01			
	SHEET 1 SUBTOTALS*		0.33			0.17		0.18	0.25	1135	799	
	SHEET 2 SUBTOTALS*		0.11			0.04		0.15	0.04	638	181	
	SHEET 3 SUBTOTALS*		0.07			0.07		0.05	0.04	425	336	
TOTALS*:			0.54			0.29		0.43	0.33	2427	1357	0

*Rounded totals are sum of actual impacts

NOTES:
 At Sites 42 and 44, the existing culvert is not buried, therefore the culvert extension will not be buried. The bottom elevation of the extended culvert will match the elevation of the existing stream bed.
 At Site 42, <0.01 ac (20 lf) of temporary impacts due to construction activities are included within the bank stabilization impacts.
 At Site 44, <0.01 ac (28 lf) of temporary impacts due to construction activities are included within the bank stabilization impacts.

NC DEPARTMENT OF TRANSPORTATION
 DIVISION OF HIGHWAYS
 07/20/20
 MECKLENBURG
 TIP NO. I-5507
 WBS NO. 43609.3.2

SHEET 115 OF 115

Revised July 2020