

Type I and II Ground Disturbing Categorical Exclusion Action Classification Form

STIP Project No.	B-5721
WBS Element	45677.1.1
Federal Project No.	BRZ-2177(001)

A. Project Description:

The North Carolina Department of Transportation (NCDOT) is proposing to replace bridge 780124, carrying SR 2177 (Dan Valley Road) over the Mayo River in Rockingham County (Figure 1). A new bridge will be constructed to the north of the existing bridge, and traffic will be maintained on the existing bridge during construction. Following construction of the new bridge, the existing bridge would be removed. The proposed action is listed in the State Transportation Improvement Program (STIP) as B-5721.

Bridge number 780124 is located in Rockingham County, just outside of the Madison town limits. The land within the immediate vicinity of the project study area is largely undeveloped. However, the Town of Madison, the Town of Mayodan, and Mayo River State Park are located adjacent to the project study area. One business is located south of the project along Dan Valley Road, and a number of single family homes are located to the east of the existing bridge.

The existing bridge includes two 10-foot travel lanes without shoulders. The bridge is approximately 235 feet long with seven spans. It is at a 15 degree skew to the river. The proposed replacement bridge would be constructed as a curved bridge, 257 feet in length, and approximately 20-30 feet north of the existing bridge. Project construction will extend approximately 900 feet to the southwest and 750 feet to the northeast from the replacement bridge along Dan Valley Road.

B. Description of Need and Purpose:

The purpose of the proposed project is to replace a deficient bridge. Bridge No. 124 is considered structurally deficient with a sufficiency rating of 13.54 out of 100. Being structurally deficient does not mean that the bridge is unsafe, but does mean the bridge is in need of repair or replacement. As a bridge ages, the cost of repairs and continued maintenance eventually necessitate the need for replacement. The current bridge was constructed in 1965 and is reaching the end of its useful life. The bridge also has a posted weight limit of 26 tons for single vehicles and 35 tons for tractor trailers.

C. Categorical Exclusion Action Classification:

TYPE I A

D. Proposed Improvements

28. Bridge rehabilitation, reconstruction, or replacement or the construction of grade separation to replace existing at-grade railroad crossings, if the actions meet the constraints in 23 CFR 771.117(e)(1-6).

E. Special Project Information:

Dan Valley Road is a two-lane undivided roadway that provides connectivity between the Town of

Madison and areas to the northeast, which include commercial and industrial development and McMichael High School. The posted speed limit is 45 mph.

Costs

Construction Cost	\$3,550,000
Right of Way Cost	\$227,000
<u>Utility Cost</u>	<u>\$268,602</u>
Total Cost	\$4,045,602

Traffic

Current (2016):	3,700 vpd
Future (2040):	6,000 vpd

Alternatives Discussion

No Build

There would be no changes to the existing bridge, which would not address the need to replace the deficient bridge.

Build Alternative 1 (Selected)

Alternative 1 would replace the bridge with a curved bridge approximately 20-30 feet north of the existing bridge. The replacement bridge would be 257 feet long. The bridge would have two 12-foot lanes, a 3-foot shoulder on the north side, and a 6-foot shoulder on the south side. Project construction would extend approximately 900 feet to the southwest and 750 feet to the northeast from the replacement bridge along Dan Valley Road. Traffic would be maintained on the existing bridge structure during construction.

Alternative 1 was selected as the preferred alternative because it includes a more desirable roadway alignment. This alternative has lower impacts to properties and lower costs than other alternatives evaluated. Alternative 1 is shown on Figure 2.

Build Alternative 2

Alternative 2 would replace the bridge with a parallel bridge approximately 10 feet north of the existing bridge. The replacement bridge would be 253 feet long. The bridge would have two 12-foot lanes and 3-foot shoulders. Project construction would extend approximately 1050 feet to the southwest and 650 feet to the northeast from the replacement bridge along Dan Valley Road. Traffic would be maintained on the existing bridge structure during construction.

Build Alternative 3

Alternative 3 would replace the bridge with a parallel bridge approximately 10 feet north of the existing bridge. The replacement bridge would be 256 feet long. The bridge would have two 12-foot lanes and 3-foot shoulders. Project construction would extend approximately 850 feet to the southwest and 1000 feet to the northeast from the replacement bridge along Dan Valley Road. This alternative would require the relocation of one residence. Traffic would be maintained on the existing bridge structure during construction.

Pedestrian and Bicycle Accommodations

The existing bridge does not include pedestrian or bicycle accommodations, and no additional accommodations are proposed with this project. However, the NCDOT Bicycle and Pedestrian Division recommends that the NCDOT coordinate with local governments regarding opportunities to provide a graded shelf underneath the bridge on the west side to accommodate future greenway construction.

The following plans recommend a greenway along the west side of the Mayo River: *Madison Rivers & Trails Plan* (2018), *Mayo River Recreation Action Plan Phase I* (2016), *Rockingham County Pathways* (2013), and *Rockingham County Comprehensive Transportation Plan* (2010).

Jurisdictional Resources

The only jurisdictional resource within the project study area is the Mayo River. There are no wetlands located within the project study area. Minor impacts from the selected alternative to the Mayo River may occur due to the placement and/or removal of bridge bents. It is anticipated that a US Army Corps of Engineers (USACE) Nationwide Permit 14 would be applicable for stream impacts, if any. The USACE holds the final discretion as to what permit may be required to authorize project construction. A Section 401 General Water Quality Certification will be needed if a Section 404 permit is required.

Protected Species

The following species are listed for Rockingham County: Roanoke logperch (*Percina rex*), James spiny mussel (*Pleurobema collina*), and smooth coneflower (*Echinacea laevigata*). The green floater (*Lasmigona subviridis*) is being evaluated by US Fish and Wildlife Service for listing under the Endangered Species Act and is known to occur in Rockingham County. Field surveys for smooth coneflower were conducted in 2016, and no individuals were observed in the study area and there are no known occurrences within 1 mile of the study area. Surveys for the aquatic species were conducted in 2018, and no individuals were identified in the study area. However, a review of NC Natural Heritage Program (NC NHP) records indicated occurrences of all three species within a 5-mile buffer of the study area, including a known occurrence of Roanoke logperch within the project study area. Biological conclusions of “May Affect, Likely to Adversely Affect” have been recommended for the Roanoke logperch, as well as for green floater (if it becomes listed). The USFWS will be contacted once final designs are prepared to request concurrence on these biological conclusions. A biological conclusion of “May Affect, Not Likely to Adversely Affect” has been recommended for James spiny mussel.

In addition, the US Fish and Wildlife Service has developed a programmatic biological opinion (PBO) in conjunction with the Federal Highway Administration (FHWA), the US Army Corps of Engineers (USACE), and NCDOT for the northern long-eared bat (NLEB) (*Myotis septentrionalis*) in eastern North Carolina. The PBO covers the entire NCDOT program in Divisions 1-8, including all NCDOT projects and activities.

Cultural Resources

NCDOT Cultural Resources staff determined that there are three potential historic sites located within the project area of potential effects, including bridge number 780124 itself, as well as two houses built in 1912 and 1922. An architectural historian conducted a site visit and noted significant alterations to the houses. The bridge does not exemplify any distinctive engineering or aesthetic type and is not eligible for the National Register of Historic Places. Therefore, no historic properties are present in the area of potential effects.

NCDOT Cultural Resources staff determined that there are no previously recorded archaeological sites or cemeteries within the project area of potential effects (APE). The bridge replacement will be constructed just north of the existing facility, and immediately south of an earlier bridge here. Much of the APE has already been modified by the construction associated with the previous two bridges and roads. It is unlikely that significant, intact otherwise unknown archaeological remains would be present and impacted by the bridge replacement project, and NCDOT Cultural Resources staff have determined that no survey for archaeological resources is required. For archaeological review, this federally permitted undertaking should be considered compliant with Section 106.

Resource Agency Input

NCDOT sought input from resource and regulatory agencies via a start of study scoping letter distributed in September 2018. Letters were sent to the following agencies. Agencies that responded with comments are marked with an asterisk (*). Agency comments are included in Attachment A.

- US Army Corps of Engineers (USACE)
- US Fish and Wildlife Service (USFWS)*
- US Department of Transportation (US DOT)
- US Environmental Protection Agency (USEPA)
- NC Division of Parks and Recreation
- NC Wildlife Resources Commission (NCWRC)*
- NC Division of Water Resources (NCDWR)
- NCDOT Bicycle and Pedestrian Division*
- NCDOT Highway Division 7*

Public Involvement

Postcards will be distributed to property owners in the vicinity of the projects to update them on the project status, preferred alternative, and project schedule.

Impact Summary

Impacts summarized below were estimated using functional design slope stake limits plus a 40-foot buffer and/or functional design right of way limits.

Length:	1,890 feet
Streams:	0 feet
Wetlands:	0 feet
100-year floodplain:	6.8 acres
Floodway:	3.8 acres
Farmland soils:	1.3 acres
Active agriculture (ac)	0 acres
Parcels:	7
Relocations:	0

F. Project Impact Criteria Checklists:

Type I & II - Ground Disturbing Actions			
FHWA APPROVAL ACTIVITIES THRESHOLD CRITERIA			
<i>If any of questions 1-7 are marked "yes" then the CE will require FHWA approval.</i>		Yes	No
1	Does the project require formal consultation with U.S. Fish and Wildlife Service (USFWS) or National Marine Fisheries Service (NMFS)?	<input type="checkbox"/>	<input checked="" type="checkbox"/>
2	Does the project result in impacts subject to the conditions of the Bald and Golden Eagle Protection Act (BGPA)?	<input type="checkbox"/>	<input checked="" type="checkbox"/>
3	Does the project generate substantial controversy or public opposition, for any reason, following appropriate public involvement?	<input type="checkbox"/>	<input checked="" type="checkbox"/>
4	Does the project cause disproportionately high and adverse impacts relative to low-income and/or minority populations?	<input type="checkbox"/>	<input checked="" type="checkbox"/>
5	Does the project involve a residential or commercial displacement, or a substantial amount of right of way acquisition?	<input type="checkbox"/>	<input checked="" type="checkbox"/>
6	Does the project require an Individual Section 4(f) approval?	<input type="checkbox"/>	<input checked="" type="checkbox"/>
7	Does the project include adverse effects that cannot be resolved with a Memorandum of Agreement (MOA) under Section 106 of the National Historic Preservation Act (NHPA) or have an adverse effect on a National Historic Landmark (NHL)?	<input type="checkbox"/>	<input checked="" type="checkbox"/>
<i>If any of questions 8 through 31 are marked "yes" then additional information will be required for those questions in Section G.</i>			
Other Considerations		Yes	No
8	Does the project result in a finding of "may affect not likely to adversely affect" for listed species, or designated critical habitat under Section 7 of the Endangered Species Act (ESA)?	<input checked="" type="checkbox"/>	<input type="checkbox"/>
9	Is the project located in anadromous fish spawning waters?	<input type="checkbox"/>	<input checked="" type="checkbox"/>
10	Does the project impact waters classified as Outstanding Resource Water (ORW), High Quality Water (HQW), Water Supply Watershed Critical Areas, 303(d) listed impaired water bodies, buffer rules, or Submerged Aquatic Vegetation (SAV)?	<input type="checkbox"/>	<input checked="" type="checkbox"/>
11	Does the project impact waters of the United States in any of the designated mountain trout streams?	<input type="checkbox"/>	<input checked="" type="checkbox"/>
12	Does the project require a U.S. Army Corps of Engineers (USACE) Individual Section 404 Permit?	<input type="checkbox"/>	<input checked="" type="checkbox"/>
13	Will the project require an easement from a Federal Energy Regulatory Commission (FERC) licensed facility?	<input type="checkbox"/>	<input checked="" type="checkbox"/>
14	Does the project include a Section 106 of the NHPA effects determination other than a no effect, including archaeological remains?	<input type="checkbox"/>	<input checked="" type="checkbox"/>

Other Considerations (continued)		Yes	No
15	Does the project involve hazardous materials and/or landfills?	<input type="checkbox"/>	<input checked="" type="checkbox"/>
16	Does the project require work encroaching and adversely affecting a regulatory floodway or work affecting the base floodplain (100-year flood) elevations of a water course or lake, pursuant to Executive Order 11988 and 23 CFR 650 subpart A?	<input checked="" type="checkbox"/>	<input type="checkbox"/>
17	Is the project in a Coastal Area Management Act (CAMA) county and substantially affects the coastal zone and/or any Area of Environmental Concern (AEC)?	<input type="checkbox"/>	<input checked="" type="checkbox"/>
18	Does the project require a U.S. Coast Guard (USCG) permit?	<input type="checkbox"/>	<input checked="" type="checkbox"/>
19	Does the project involve construction activities in, across, or adjacent to a designated Wild and Scenic River present within the project area?	<input type="checkbox"/>	<input checked="" type="checkbox"/>
20	Does the project involve Coastal Barrier Resources Act (CBRA) resources?	<input type="checkbox"/>	<input checked="" type="checkbox"/>
21	Does the project impact federal lands (e.g. U.S. Forest Service (USFS), USFWS, etc.) or Tribal Lands?	<input type="checkbox"/>	<input checked="" type="checkbox"/>
22	Does the project involve any changes in access control?	<input type="checkbox"/>	<input checked="" type="checkbox"/>
23	Does the project have a permanent adverse effect on local traffic patterns or community cohesiveness?	<input type="checkbox"/>	<input checked="" type="checkbox"/>
24	Will maintenance of traffic cause substantial disruption?	<input type="checkbox"/>	<input checked="" type="checkbox"/>
25	Is the project inconsistent with the STIP or the Metropolitan Planning Organization's (MPO's) Transportation Improvement Program (TIP) (where applicable)?	<input type="checkbox"/>	<input checked="" type="checkbox"/>
26	Does the project require the acquisition of lands under the protection of Section 6(f) of the Land and Water Conservation Act, the Federal Aid in Fish Restoration Act, the Federal Aid in Wildlife Restoration Act, Tennessee Valley Authority (TVA), or other unique areas or special lands that were acquired in fee or easement with public-use money and have deed restrictions or covenants on the property?	<input type="checkbox"/>	<input checked="" type="checkbox"/>
27	Does the project involve Federal Emergency Management Agency (FEMA) buyout properties under the Hazard Mitigation Grant Program (HMGP)?	<input type="checkbox"/>	<input checked="" type="checkbox"/>
28	Does the project include a <i>de minimis</i> or programmatic Section 4(f)?	<input type="checkbox"/>	<input checked="" type="checkbox"/>
29	Is the project considered a Type I under the NCDOT's Noise Policy?	<input type="checkbox"/>	<input checked="" type="checkbox"/>
30	Is there prime or important farmland soil impacted by this project as defined by the Farmland Protection Policy Act (FPPA)?	<input checked="" type="checkbox"/>	<input type="checkbox"/>
31	Are there other issues that arose during the project development process that affected the project decision?	<input type="checkbox"/>	<input checked="" type="checkbox"/>

G. Additional Documentation as Required from Section F

Question 1 – Formal Consultation with the USFWS

It has not yet been determined whether formal consultation with the USFWS will be required. The USFWS will be contacted once final designs are prepared, and if necessary consultation will be initiated to address impacts to Roanoke logperch and Green floater.

Question 8 – Protected Species

A Natural Resources Technical Report (NRTR) for this project, including surveys for protected plant species, was completed in 2016, and surveys for protected aquatic species were conducted in 2018. No individuals were identified during surveys for protected species within the project study area, but based on habitat and proximity to known NC Natural Heritage Program (NHP) occurrences, the following biological conclusions were made:

Species	Status	Biological Conclusion
Roanoke logperch	Endangered	May Affect, Likely to Adversely Affect
Green floater	At Risk Species	May Affect, Likely to Adversely Affect
James spinymussel	Endangered	May Affect, Not Likely to Adversely Affect
Smooth coneflower	Endangered	No Effect

The USFWS will be contacted once final designs are underway to request concurrence on these biological conclusions.

Although not individually listed for Rockingham County, the USFWS has developed a programmatic biological opinion (PBO) in conjunction with the Federal Highway Administration (FHWA), the US Army Corps of Engineers (USACE), and NCDOT for the northern long-eared bat (NLEB) in eastern North Carolina. The programmatic determination for NLEB for the NCDOT program in Divisions 1 through 8 is “May Affect, Likely to Adversely Affect”. The PBO provides incidental take coverage for NLEB and will ensure compliance with Section 7 of the Endangered Species Act for five years for all NCDOT projects with a federal nexus in Divisions 1-8, which includes Rockingham County, where B-5721 is located. This level of incidental take is authorized from the effective date of final listing through April 30, 2020.

Question 16 – Floodplains

The project will require grading and construction within the 100-year floodplain and regulatory floodway associated with the Mayo River.

Question 30 – Farmland Soils

A preliminary screening of farmland conversion impacts in the project area has been completed (NRCS Form AD-1006, Part VI only) and a total score of 37 out of 160 points was calculated for the project site (CIA, 2019). Since the total site assessment score does not exceed the 60-point threshold established by NRCS, farmland conversion impacts may be anticipated, but are not considered notable. Based on functional design slope stake limits plus a 40-foot buffer, it is estimated that the project would impact 1.3 acres of farmland soils.

H. Project Commitments

**Rockingham County
Replace Bridge 780124 over Mayo River in Madison
Federal Project No. BRZ-2177(001)
WBS No. 45677.1.1
TIP No. B-5721**

NCDOT Division 7 Construction – Northern long-eared Bat

The USFWS has developed a programmatic biological opinion (PBO) in conjunction with Federal Highway Administration (FHWA), the USACE and NCDOT for the northern long-eared bat (NLEB) in eastern North Carolina. The PBO covers the entire NCDOT program in Divisions 1-8, including all NCDOT projects and activities. The programmatic determination for NLEB for the NCDOT program is “May Affect, Likely to Adversely Affect”. The PBO provides incidental take coverage for NLEB and will ensure compliance with Section 7 of the Endangered Species Act for five years for all NCDOT projects with a federal nexus in Divisions 1-8, which includes Rockingham County, where B-5721 is located. This level of incidental take is authorized from the effective date of final listing through April 30, 2020.

After project completion, the contract administrator for construction must submit the actual amount of tree clearing reported in tenths of acres. This information should be submitted to the NCDOT Biological Surveys group.

NCDOT EAU – Threatened and Endangered Species

The USFWS will be contacted once final designs are prepared to request concurrence on the biological conclusions for Roanoke logperch, as well as for green floater (if it becomes listed).

NCDOT Division 7 Construction– Erosion and Sediment Control

Due to the proximity of the project to the Mayo River, NCDOT will follow *Design Standards in Sensitive Watersheds* guidelines for implementing erosion and sediment control BMPs for this project.

NCDOT Hydraulics Unit – FEMA

The Hydraulics Unit will coordinate with the NC Floodplain Mapping Program (FMP), to determine status of project with regard to applicability of NCDOT’S Memorandum of Agreement, or approval of a Conditional Letter of Map Revision (CLOMR) and subsequent final Letter of Map Revision (LOMR).

NCDOT Division 7 Construction – FEMA

This project involves construction activities on or adjacent to FEMA-regulated stream(s). Therefore, the Division shall submit sealed as-built construction plans to the Hydraulics Unit upon completion of project construction, certifying that the drainage structure(s) and roadway embankment that are located within the 100-year floodplain were built as shown in the construction plans, both horizontally and vertically.

I. Categorical Exclusion Approval

STIP Project No.	<u>B-5721</u>
WBS Element	<u>45677.1.1</u>
Federal Project No.	<u>BRZ-2177(001)</u>

Prepared By:

4/8/2019

Date

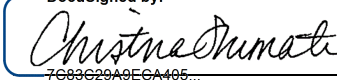
DocuSigned by:

7C83629A8E6A405
 Christina Shumate, AICP
 AECOM

Prepared For:

North Carolina Department of Transportation, Structures Management Unit

Reviewed By:

4/8/2019

Date

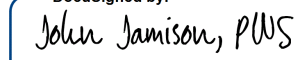
DocuSigned by:

89F63E75FD11458
 John Jamison, PWS
 North Carolina Department of Transportation, Environmental Policy Unit



Approved

If all of the threshold questions (1 through 7) of Section F are answered "no," NCDOT approves this Categorical Exclusion.



Certified

If any of the threshold questions (1 through 7) of Section F are answered "yes," NCDOT certifies this Categorical Exclusion.

4/12/2019

Date

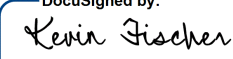
DocuSigned by:

ED19A18D98EC496
 Kevin Fisher, P.E.
 North Carolina Department of Transportation, Structures Management Unit

FHWA Approved:

For Projects Certified by NCDOT (above), FHWA signature required.

Date

 John F. Sullivan, III, PE, Division Administrator
 Federal Highway Administration

Figures

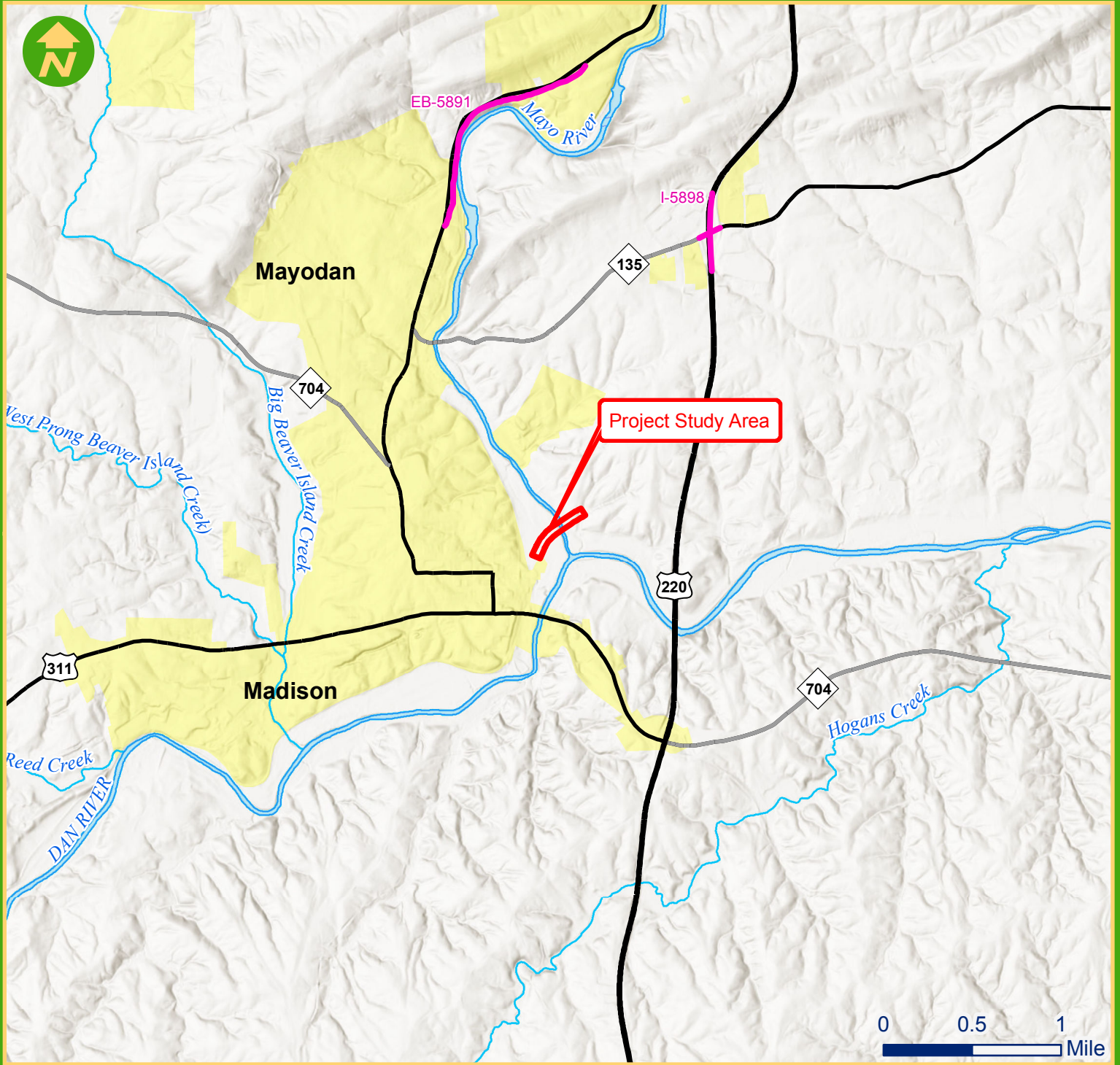

B-5721
Bridge Replacement at
SR 2177 over Mayo River
Rockingham County



Figure 1
Vicinity Map
 February 2019

Legend

- Streams
- STIP Project 2018-2027
- NC Route
- US Route
- Project Study Area
- Waterbody
- Municipal Boundary



This map is for reference only.
 Sources: Data was received by
 NC Department of Transportation,
 ESRI, NCONemap

PROJECT REFERENCE NO. <i>B-5721</i>		SHEET NO. <i>2A-1</i>	
ROADWAY DESIGN ENGINEER		PAVEMENT DESIGN ENGINEER	
INCOMPLETE PLANS DO NOT USE FOR R/W ACQUISITION			
Prepared in the Office of: AECOM			
<small>NC FIRM LICENSE No. F-0142 701 Corporate Center Drive, Suite 475 Raleigh, NC 27607 (919) 854-6000 • (919) 854-6259 FAX</small>			
DOCUMENT NOT CONSIDERED FINAL UNLESS ALL SIGNATURES COMPLETED			

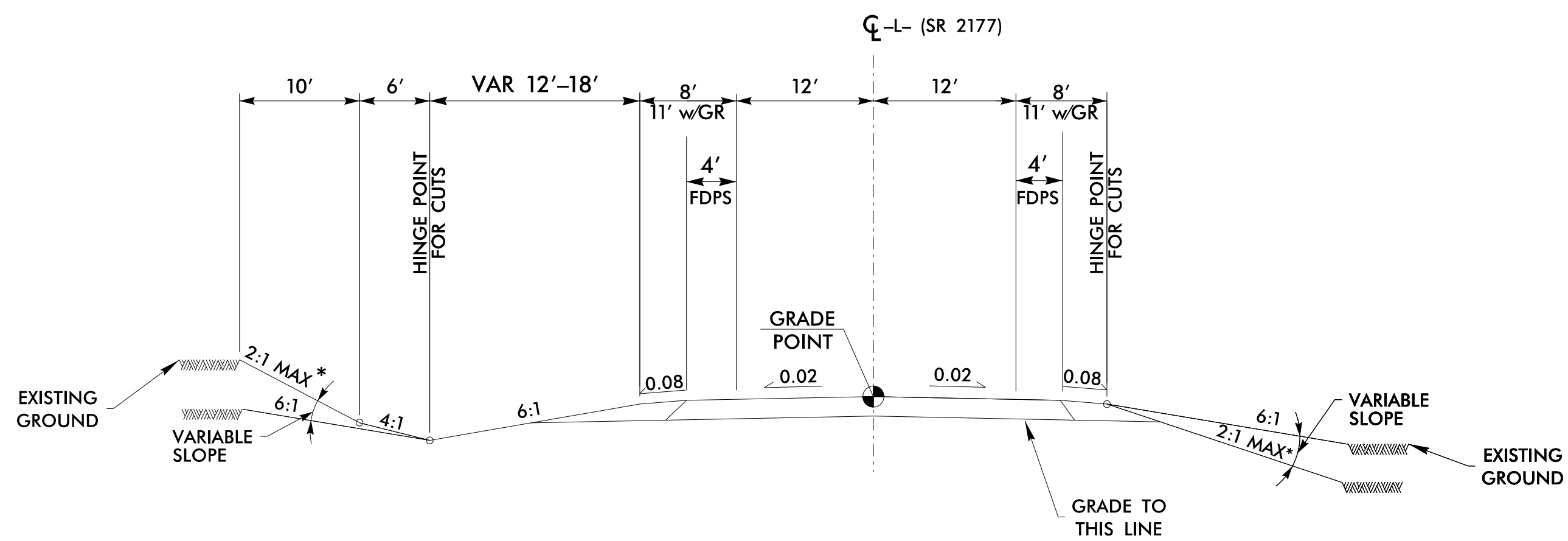

TYPICAL SECTION NO. 1

* OR AS SPECIFIED IN GEOTECHNICAL RECOMMENDATIONS

- USE TYPICAL SECTION NO. 1
- L1- STA. 11+74.55 TO 20+55 +/- (BEGIN BRIDGE)
 - L1- STA. 23+12 +/- (END BRIDGE) TO 30+62.46
 - L2- STA. 10+00 TO 20+68 +/- (BEGIN BRIDGE)
 - L2- STA. 23+21 +/- (END BRIDGE) TO 29+59.55
 - L3- STA. 11+80.43 TO 20+14 +/- (BEGIN BRIDGE)
 - L3- STA. 22+70 +/- (END BRIDGE) TO 32+77.93

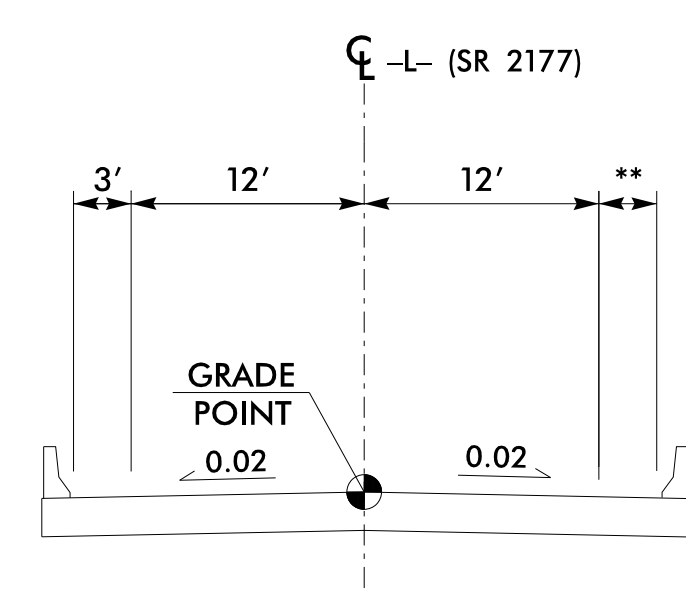



TYPICAL SECTION NO. 2

** FOR ALT 1 USE 6' TO WIDEN FOR SSD FOR ALTS 2, 3 USE 3'

- USE TYPICAL SECTION NO. 2
- L1- STA. 20+55 +/- TO 23+12 +/-
 - L2- STA. 20+68 +/- TO 23+21 +/-
 - L3- STA. 20+14 +/- TO 22+70 +/-

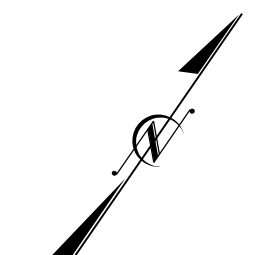
ALTERNATIVE 1 BRIDGE RELOCATED TO NORTH





PRELIMINARY PLANS
SUBJECT TO CHANGE WITHOUT NOTICE

PROJECT REFERENCE NO. <i>B-5721</i>	SHEET NO. <i>ALT1-4</i>
RW SHEET NO.	
ROADWAY DESIGN ENGINEER	PAVEMENT DESIGN ENGINEER
<div style="border: 1px solid black; padding: 5px; margin: 5px auto; width: 80%;"> INCOMPLETE PLANS DO NOT USE FOR R/W ACQUISITION </div>	
Prepared in the Office of: AECOM	
NC FIRM LICENSE No. F-0542 70 Corporate Center Dr., Suite 475 Cary, NC 27513 (919) 854-6200 • (919) 854-6299 (FAX)	
DOCUMENT NOT CONSIDERED FINAL UNLESS ALL SIGNATURES COMPLETED	

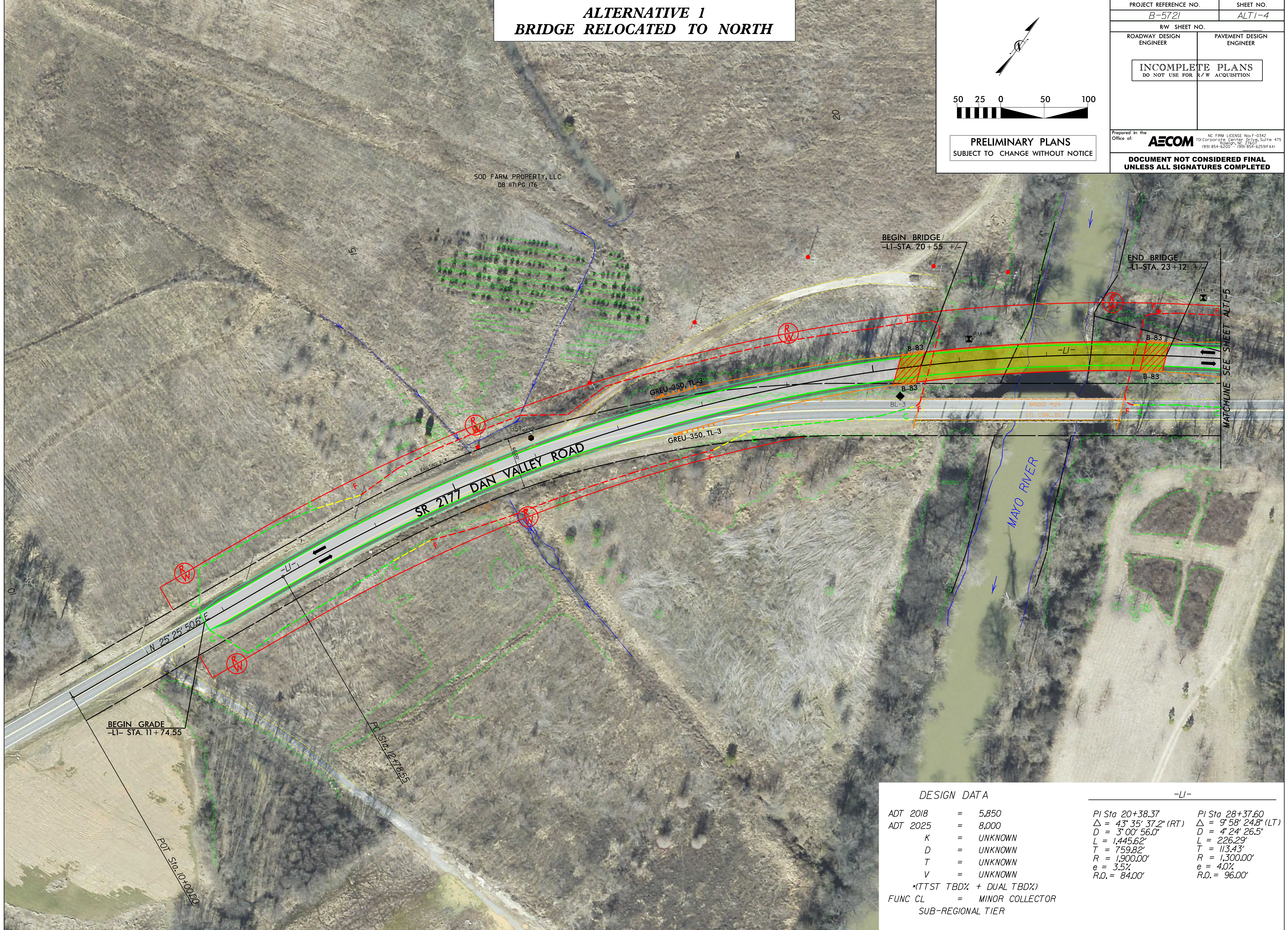

FUNCTIONAL DESIGN
 PROPOSED TRP B-5721 RWS 467711
 ROCKINGHAM COUNTY
 REPLACE BRIDGE 78024 ON
 SR 2177 (DAN VALLEY ROAD)
 OVER MAYO RIVER
 ALTERNATIVE 1

FUNCTIONAL DESIGN
 PROPOSED TRP B-5721 RWS 467711
 ROCKINGHAM COUNTY
 REPLACE BRIDGE 78024 ON
 SR 2177 (DAN VALLEY ROAD)
 OVER MAYO RIVER
 ALTERNATIVE 1

DESIGN DATA		-LI-	
ADT 2018	= 5,850	PI Sta 20+38.37	PI Sta 28+37.60
ADT 2025	= 8,000	$\Delta = 43^{\circ} 35' 37.2"$ (RT)	$\Delta = 9^{\circ} 58' 24.8"$ (LT)
K	= UNKNOWN	D = 3' 00" 56.0'	D = 4' 24" 26.5'
D	= UNKNOWN	L = 1,445.62'	L = 226.29'
T	= UNKNOWN	T = 759.82'	T = 113.43'
V	= UNKNOWN	R = 1,900.00'	R = 1,300.00'
		e = 3.5%	e = 4.0%
		R.O. = 84.00'	R.O. = 96.00'
*(TTST TBD% + DUAL TBD%)			
FUNC CL = MINOR COLLECTOR			
SUB-REGIONAL TIER			

ALTERNATIVE 1 BRIDGE RELOCATED TO NORTH

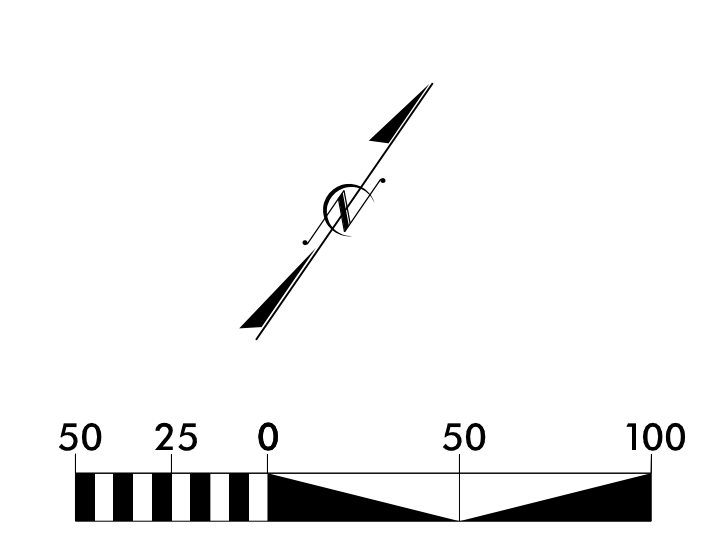

PROJECT REFERENCE NO. B-5721	SHEET NO. ALT1-5
R/W SHEET NO.	
ROADWAY DESIGN ENGINEER	PAVEMENT DESIGN ENGINEER
INCOMPLETE PLANS DO NOT USE FOR R/W ACQUISITION	
Prepared in the Office of:	
AECOM	
<small>NC FIRM LICENSE NO. F-0542 70 Corporate Center Dr., Suite 475 Raleigh, NC 27603 (919) 854-6200 • (919) 854-6299 (FAX)</small>	
DOCUMENT NOT CONSIDERED FINAL UNLESS ALL SIGNATURES COMPLETED	

PRELIMINARY PLANS
SUBJECT TO CHANGE WITHOUT NOTICE

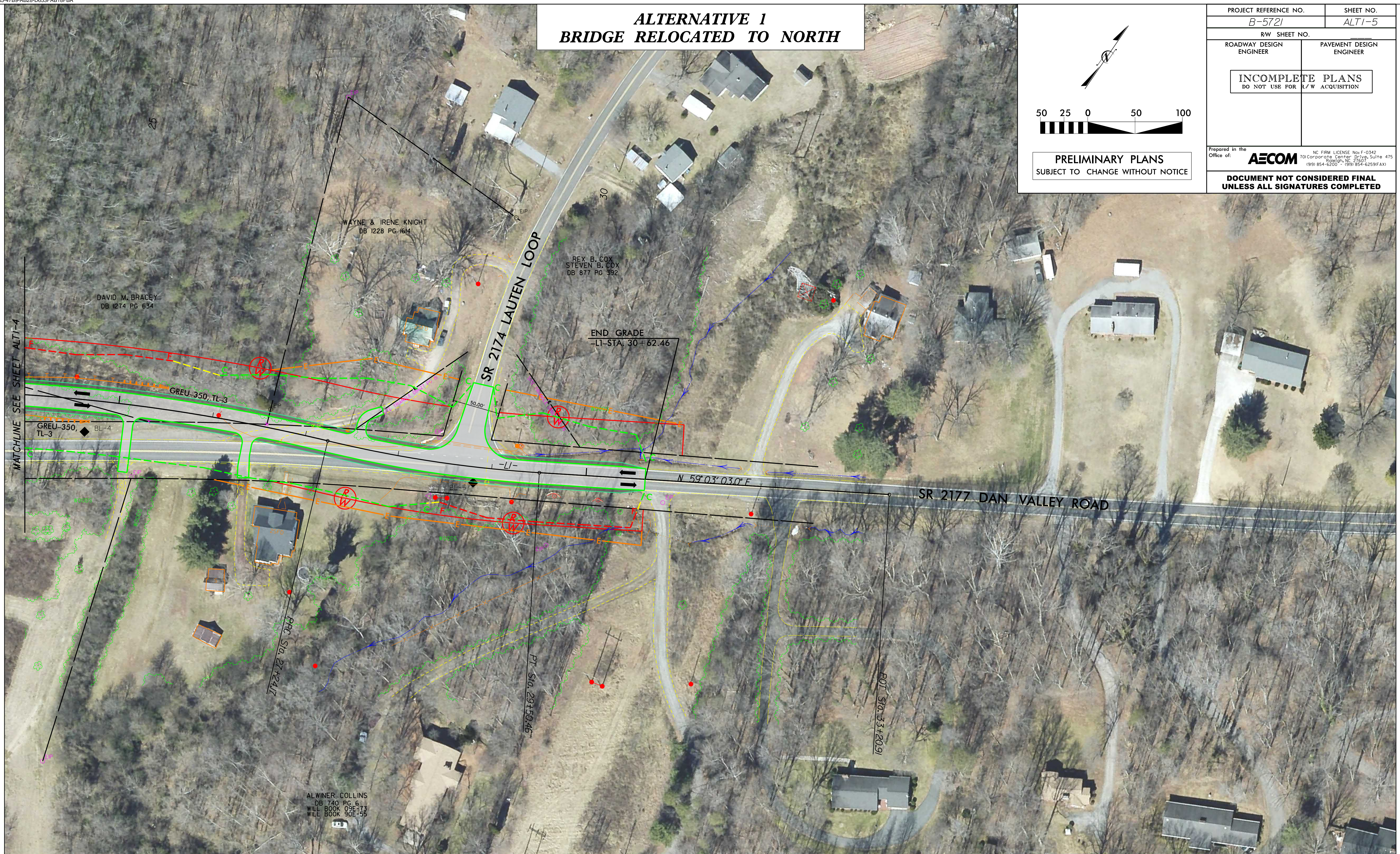

FUNCTIONAL DESIGN
 PROPOSED TYP. B-SIZE PMS 460711
 ROCKINGHAM COUNTY
 REPLACE BRIDGE 78024 ON
 SR 2177 (DAN VALLEY ROAD)
 OVER MAHO RIVER
 ALTERNATIVE 1

FUNCTIONAL DESIGN
 PROPOSED TYP. B-SIZE PMS 460711
 ROCKINGHAM COUNTY
 REPLACE BRIDGE 78024 ON
 SR 2177 (DAN VALLEY ROAD)
 OVER MAHO RIVER
 ALTERNATIVE 1

DESIGN DATA		-LI-	
ADT 2018	= 5,850	PI Sta 20+38.37	PI Sta 28+37.60
ADT 2025	= 8,000	$\Delta = 43^{\circ} 35' 37.2''$ (RT)	$\Delta = 9^{\circ} 58' 24.8''$ (LT)
K	= UNKNOWN	D = 3' 00" 56.0"	D = 4' 24" 26.5"
D	= UNKNOWN	L = 1,445.62'	L = 226.29'
T	= UNKNOWN	T = 759.82'	T = 113.43'
V	= UNKNOWN	R = 1,900.00'	R = 1,300.00'
		e = 3.5%	e = 4.0%
		R.O. = 84.00'	R.O. = 96.00'
*(TTST TBD% + DUAL TBD%)			
FUNC CL = MINOR COLLECTOR			
SUB-REGIONAL TIER			

Attachment A

Agency Correspondence

Agency Comments on Start of Study Letter

NCDOT Highway Division 7 (September 19, 2018)
Needs T&E study for the Roanoke logperch. This project may require a Section 7 review.
No bents in the water.
I recommend using the existing bridge as the onsite detour and building the new structure to the north.
Remove any existing footing that are in the water for the safety of canoes and kayaks.
North Carolina Division of Parks and Recreation (September 24, 2018)
Based on the projects as proposed, the NC Division of Parks and Recreation has no objections and therefore no comments.
North Carolina Wildlife Resources Commission (September 25, 2018)
The potential exist for Roanoke logperch (<i>Percina rex</i> : state E, federal E) to be found at this site. NCDOT should coordinate with NCWRC and USFWS in conducting a survey to determine the presence or absence of this species. We recommend replacing this bridge with a bridge. Standard recommendations apply.
US Fish and Wildlife Service (September 26, 2018)
Due to the known occurrence of the federally endangered Roanoke Logperch (<i>Percina rex</i>) in the vicinity of B-5721, a formal Section 7 consultation may be required for B-5721 for that species. A fish survey should be conducted at the project site. Also, although not previously found in the vicinity of this project, the federally endangered James River Spiny mussel (<i>Parvaspina collina</i>) is known to occur upstream in the Mayo River. If appropriate habitat occurs within the project vicinity, a mussel survey should also be conducted.
NCDOT Bicycle and Pedestrian Division (October 18, 2018)
NCDOT should coordinate with local governments regarding opportunities to provide a graded shelf underneath the bridge to accommodate future greenway construction.

Attachment B
Cultural Resources
No Survey Required
Forms

16-01-0115



HISTORIC ARCHITECTURE AND LANDSCAPES NO HISTORIC PROPERTIES PRESENT OR AFFECTED FORM

This form only pertains to Historic Architecture and Landscapes for this project. It is not valid for Archaeological Resources. You must consult separately with the Archaeology Group.

PROJECT INFORMATION

Project No:	B-5721	County:	Rockingham
WBS No.:	45677.1.1	Document Type:	CE
Fed. Aid No:	BRZ-2177 (001)	Funding:	<input type="checkbox"/> State <input checked="" type="checkbox"/> Federal
Federal Permit(s):	<input checked="" type="checkbox"/> Yes <input type="checkbox"/> No	Permit Type(s):	NWP
<u>Project Description:</u>			
Replace Bridge No. 124 on SR 2177 (N. Water St) over Mayo River.			

SUMMARY OF HISTORIC ARCHITECTURE AND LANDSCAPES REVIEW

- There are no National Register-listed or Study Listed properties within the project's area of potential effects.
- There are no properties less than fifty years old which are considered to meet Criteria Consideration G within the project's area of potential effects.
- There are no properties within the project's area of potential effects.
- There are properties over fifty years old within the area of potential effects, but they do not meet the criteria for listing on the National Register.
- There are no historic properties present or affected by this project. (Attach any notes or documents as needed.)

Date of field visit: April 8, 2016

Description of review activities, results, and conclusions:

On February 11, 2016 a search of NC HPOWEB GIS Service map and the Rockingham County Tax GIS data reveal that an identified historic site, Bridge No. 124 (RK1122) in the Area of Potential Effects for this project, as well as two houses built in 1912 and 1922. An Architectural Historian conducted a site visit to determine if further study is required. Both of the houses have evidence of significant alterations; windows and doors replaced, and new exterior siding. The bridge itself, Rockingham County Bridge No. 124, was built in 1965 was identified as a Surveyed Site. The structure does not exemplify any distinctive engineering or aesthetic type and is not eligible for the National Register of Historic Places. Therefore, no historic properties are present in the Area of Potential Effects of this project.

SUPPORT DOCUMENTATION

Map(s) Previous Survey Info. Photos Correspondence Design Plans

FINDING BY NCDOT ARCHITECTURAL HISTORIAN

Historic Architecture and Landscapes – **NO HISTORIC PROPERTIES PRESENT OF AFFECTED**

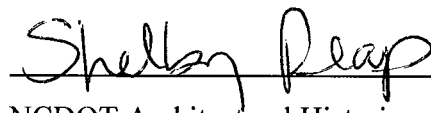
NCDOT Architectural Historian

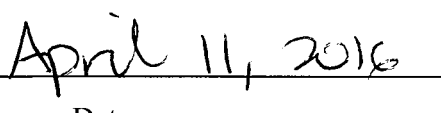
Date

16-01-0115



NO ARCHAEOLOGICAL SURVEY REQUIRED FORM

This form only pertains to ARCHAEOLOGICAL RESOURCES for this project. It is not valid for Historic Architecture and Landscapes. You must consult separately with the Historic Architecture and Landscapes Group.



PROJECT INFORMATION

Project No: **B-5721** *County:* **Rockingham**
WBS No: **45677.1.1** *Document:* **Ce**
F.A. No: **BRZ-2177(001)** *Funding:* State Federal

Federal Permit Required? Yes No *Permit Type:* **usace**

Project Description: NCDOT proposes to replace Bridge No. 124 on SR 2177 (Dan Valley Road) over the Mayo River in Rockingham County. A new bridge is proposed north of the existing Br. No. 124 with traffic being maintained on the current bridge. The proposed length of the new project is about 1890 feet. Preliminary design plans were available at the time of the review and establishes a width of about 150 feet skewed to the north though some new work will be required on the south side near each endpoint. For purposes of this review, the archaeological Area of Potential Effects (APE) is 1890 feet in length with a width of 150 feet which will include all new ROW, cut and fill lines, and also any necessary easements. This is a federally funded undertaking that will also require USACE permitting, therefore Section 106 of the National Historic Preservation Act applies for archaeological review.

SUMMARY OF CULTURAL RESOURCES REVIEW

Brief description of review activities, results of review, and conclusions:

The bridge to be replaced is in a rural setting. USGS mapping (Mayodan) and aerial photography was studied (see Figures 1 and 2). Google streetview tool was available at this location and used, though Bing lacked the data here. The existing bridge crosses the Mayo River, here a notable flow of water. The Dan River is present about 1000 feet to the south where the two rivers meet. To the north about 100 feet of the current bridge is an older bridge crossing with abutments still present. These can be seen clearly in the virtual driveby and the abandoned approaching road is quite visible in aerial photography. The surroundings are open grassy fields or woods.

According to USGS mapping and GIS resources (data layer created by NCDOT archaeologist Paul J. Mohler), no cemetery is present at the APE or immediately nearby. Historic maps were examined which show that the new bridge was built in the 1960s. The Rockingham County Highway Map from 1938 (MC.084.1938n) shows a crossing at or very near the APE, but no structures or other notations were depicted near the bridge crossing.

The Office of State Archaeology was visited to review archaeological mapping and to reference any known archaeological surveys and sites. This helps establish an archaeological context for comparison. An archaeological survey was conducted of the Mayo River here, focusing on the west bank. While no sites were documented within the APE, site 31Rk3 is mapped north of the project area about three hundred feet north of the old bridge and roadbed, outside of the APE. The site is unassessed but is unlikely to be encountered during the proposed construction. Another documented site is the above ground remains of the "Mayo River Sluice," 31Rk59, recorded during the Dan River Navigation System and is listed on the National Register of Historic Places. This resource is located about 1700 feet south and, outside of the APE, will not be affected by the project. Another more recent NCDOT survey (PA 16-01-0087) found no archaeological sites on a bridge replacement over the Dan River further west a few miles on the other side of Madison.

16-01-0115

A large portion of the APE has been modified by the construction of the existing SR 2177 and Bridge No. 124, and prior to that impacts from the older roadway now since abandoned. The older roadbed is encountered at the southern limits, but also at the north banks of the river for three hundred feet or so.

Brief Explanation of why the available information provides a reliable basis for reasonably predicting that there are no unidentified historic properties in the APE:

The bridge replacement will be constructed on just north of the existing facility, and immediately south of an earlier bridge here. Much of the APE has already been modified by the construction associated with the previous two bridges and roads, a generally disturbed context which is not favorable for preservation of intact, significant archaeological sites. Previous archaeological reviews and surveys documented no archaeological sites or cemeteries within the APE and nearby resources are not likely to be encountered.

The context doesn't indicate a high probability for archaeological sites within the APE. It is unlikely that significant, intact otherwise unknown archaeological remains would be present and impacted by the bridge replacement project. For archaeological review, this federally permitted undertaking should be considered compliant with Section 106.

SUPPORT DOCUMENTATION

See attached: Map(s) Previous Survey Info Photos Correspondence
 Photocopy of County Survey Notes Other:

FINDING BY NCDOT ARCHAEOLOGIST

NO ARCHAEOLOGY SURVEY REQUIRED

NCDOT ARCHAEOLOGIST

2/13/2019

Date