

09/28/19

TIP PROJECT: R-2527

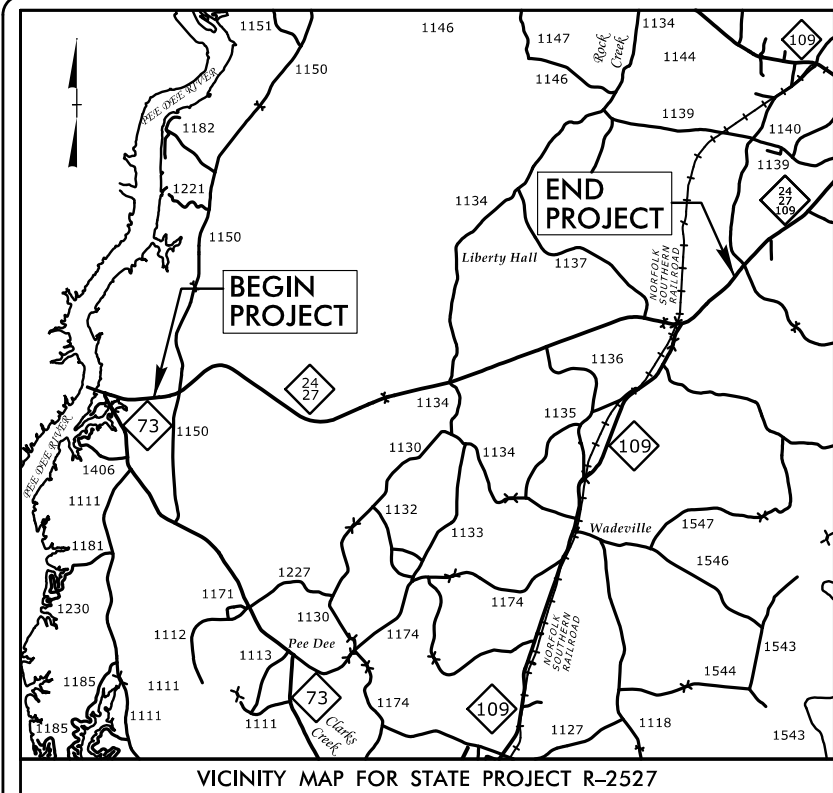

VICINITY MAP FOR STATE PROJECT R-2527
See Sheet 1A For Index of Sheets
See Sheet 1B For Conventional Symbols

STATE OF NORTH CAROLINA
DIVISION OF HIGHWAYS

MONTGOMERY COUNTY

LOCATION: NC 24-27 FROM NC 73 TO THE TROY BYPASS
TYPE OF WORK: GRADING, PAVING, DRAINAGE, STRUCTURE, CULVERTS, AND RAILROAD TRACKWORK

CONCURRENCE POINT 4B MEETING DRAINAGE PLANS - 12/3/2019

STATE	STATE PROJECT REFERENCE NO.	SHEET NO.	TOTAL SHEETS
N.C.	R-2527	1	
STATE PROJ. NO.	F.A. PROJ. NO.	DESCRIPTION	
35572.1.1	N/A	P.E.	
35572.2.1	N/A	RIGHT OF WAY	
35572.2.3	N/A	UTILITIES	

FINAL RIGHT OF WAY PLANS

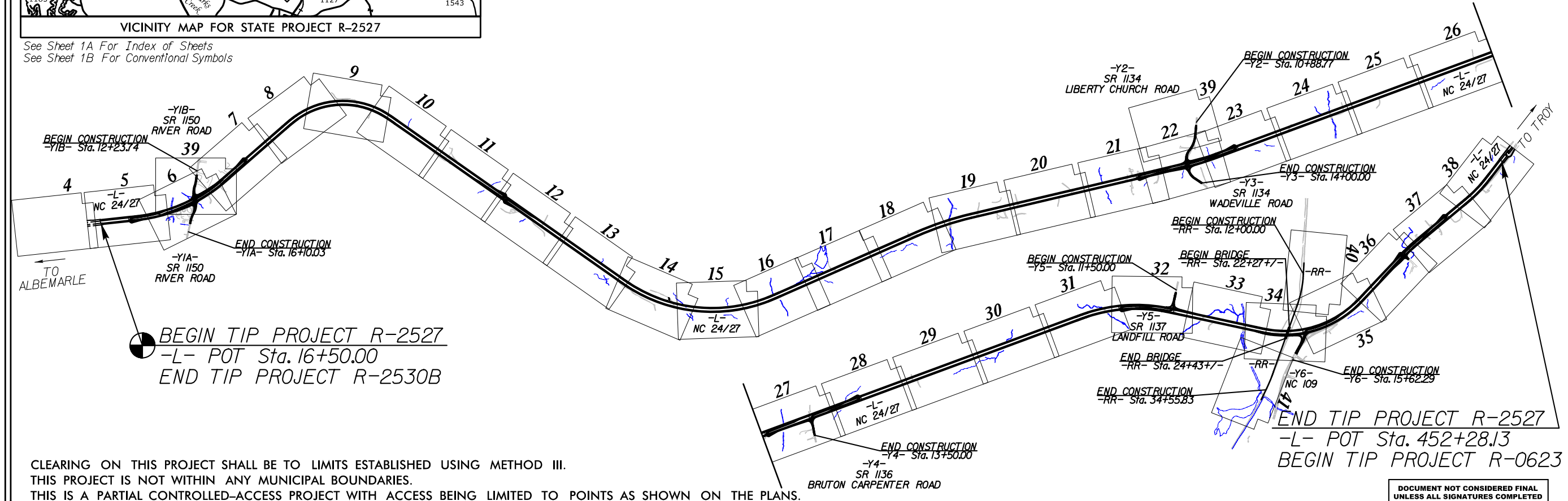

CLEARING ON THIS PROJECT SHALL BE TO LIMITS ESTABLISHED USING METHOD III.
THIS PROJECT IS NOT WITHIN ANY MUNICIPAL BOUNDARIES.
THIS IS A PARTIAL CONTROLLED-ACCESS PROJECT WITH ACCESS BEING LIMITED TO POINTS AS SHOWN ON THE PLANS.

DOCUMENT NOT CONSIDERED FINAL UNLESS ALL SIGNATURES COMPLETED

CONTRACT:

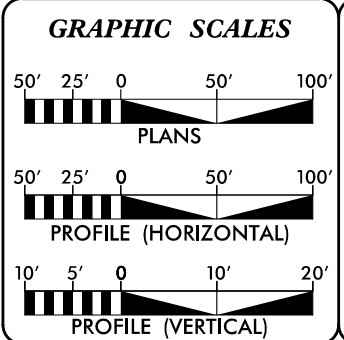

DESIGN DATA

ADT 2021 =	11,839
ADT 2041 =	14,535
K =	9%
D =	55%
T =	14% *
V =	60 MPH
* TTST = 8% DUAL 6%	
FUNC CLASS =	RURAL MINOR ARTERIAL
REGIONAL TIER	

PROJECT LENGTH

LENGTH ROADWAY TIP PROJECT R-2527	=	8.253 mi.
LENGTH STRUCTURES TIP PROJECT R-2527	=	0.000 mi.
TOTAL LENGTH TIP PROJECT R-2527	=	8.253 mi.

Prepared in the Offices of:

2018 STANDARD SPECIFICATIONS

RIGHT OF WAY DATE:
FEBRUARY 27, 2019

LETTING DATE:
FEBRUARY 16, 2021

VHB Engineering NC, P.C. (C-3705)
940 Main Campus Drive, Suite 500
Raleigh, NC 27606

ANDY YOUNG, PE
PROJECT ENGINEER

MICHAEL BURNS, PE
PROJECT DESIGN ENGINEER

PAMELA R. WILLIAMS
NCDOT CONTACT

HYDRAULICS ENGINEER

SIGNATURE: _____ P.E.

ROADWAY DESIGN ENGINEER

SIGNATURE: _____ P.E.

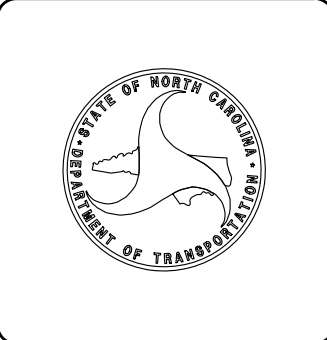

8:36:07 AM R:\Roadway\Proj\N2527-RDY_TSH.dgn

STATE OF NORTH CAROLINA, DIVISION OF HIGHWAYS CONVENTIONAL PLAN SHEET SYMBOLS

BOUNDARIES AND PROPERTY:

State Line	-----
County Line	-----
Township Line	-----
City Line	-----
Reservation Line	-----
Property Line	-----
Existing Iron Pin	○ EP
Computed Property Corner	✕
Property Monument	□ ECM
Parcel/Sequence Number	①23
Existing Fence Line	-x-x-x-
Proposed Woven Wire Fence	○
Proposed Chain Link Fence	□
Proposed Barbed Wire Fence	◇
Existing Wetland Boundary	---WLB---
Proposed Wetland Boundary	WLB
Existing Endangered Animal Boundary	---EAB---
Existing Endangered Plant Boundary	---EPB---
Existing Historic Property Boundary	---HPB---
Known Contamination Area: Soil	☠-S-☠
Potential Contamination Area: Soil	☠-S-☠
Known Contamination Area: Water	☠-W-☠
Potential Contamination Area: Water	☠-W-☠
Contaminated Site: Known or Potential	☠?

BUILDINGS AND OTHER CULTURE:

Gas Pump Vent or U/G Tank Cap	○
Sign	○ S
Well	○ W
Small Mine	✕
Foundation	□
Area Outline	□
Cemetery	□
Building	□
School	□
Church	□
Dam	□

HYDROLOGY:

Stream or Body of Water	-----
Hydro, Pool or Reservoir	-----
Jurisdictional Stream	---JS---
Buffer Zone 1	---BZ 1---
Buffer Zone 2	---BZ 2---
Flow Arrow	←
Disappearing Stream	→
Spring	○
Wetland	▽
Proposed Lateral, Tail, Head Ditch	-----
False Sump	▽

RAILROADS:

Standard Gauge	-----
RR Signal Milepost	○ MILEPOST 35
Switch	□ SWITCH
RR Abandoned	-----
RR Dismantled	-----

RIGHT OF WAY & PROJECT CONTROL:

Secondary Horiz and Vert Control Point	◆
Primary Horiz Control Point	○
Primary Horiz and Vert Control Point	◆
Exist Permanent Easement Pin and Cap	◇
New Permanent Easement Pin and Cap	◆
Vertical Benchmark	⊠
Existing Right of Way Marker	△
Existing Right of Way Line	-----
New Right of Way Line	○ RW
New Right of Way Line with Pin and Cap	○ RW ◆
New Right of Way Line with Concrete or Granite RW Marker	○ RW ◆
New Control of Access Line with Concrete C/A Marker	○ CA
Existing Control of Access	○ CA
New Control of Access	○ CA
Existing Easement Line	---E---
New Temporary Construction Easement	---E---
New Temporary Drainage Easement	---TDE---
New Permanent Drainage Easement	---PDE---
New Permanent Drainage / Utility Easement	---DUE---
New Permanent Utility Easement	---PUE---
New Temporary Utility Easement	---TUE---
New Aerial Utility Easement	---AUE---

ROADS AND RELATED FEATURES:

Existing Edge of Pavement	-----
Existing Curb	-----
Proposed Slope Stakes Cut	---C---
Proposed Slope Stakes Fill	---F---
Proposed Curb Ramp	---CR---
Existing Metal Guardrail	-----
Proposed Guardrail	-----
Existing Cable Guiderail	-----
Proposed Cable Guiderail	-----
Equality Symbol	⊕
Pavement Removal	⊗

VEGETATION:

Single Tree	○
Single Shrub	○

Note: Not to Scale

*S.U.E. = Subsurface Utility Engineering

Hedge	-----
Woods Line	-----
Orchard	-----
Vineyard	-----

EXISTING STRUCTURES:

MAJOR:	
Bridge, Tunnel or Box Culvert	CONC
Bridge Wing Wall, Head Wall and End Wall	CONC WW
MINOR:	
Head and End Wall	CONC HW
Pipe Culvert	-----
Footbridge	-----
Drainage Box: Catch Basin, DI or JB	□ CB
Paved Ditch Gutter	-----
Storm Sewer Manhole	○ S
Storm Sewer	---S---

UTILITIES:

POWER:	
Existing Power Pole	●
Proposed Power Pole	○
Existing Joint Use Pole	●
Proposed Joint Use Pole	○
Power Manhole	○ P
Power Line Tower	⊠
Power Transformer	⊞
U/G Power Cable Hand Hole	○
H-Frame Pole	●
U/G Power Line LOS B (S.U.E.*)	---P---
U/G Power Line LOS C (S.U.E.*)	---P---
U/G Power Line LOS D (S.U.E.*)	---P---

TELEPHONE:

Existing Telephone Pole	●
Proposed Telephone Pole	○
Telephone Manhole	○ T
Telephone Pedestal	□
Telephone Cell Tower	⊕
U/G Telephone Cable Hand Hole	○
U/G Telephone Cable LOS B (S.U.E.*)	---T---
U/G Telephone Cable LOS C (S.U.E.*)	---T---
U/G Telephone Cable LOS D (S.U.E.*)	---T---
U/G Telephone Conduit LOS B (S.U.E.*)	---TC---
U/G Telephone Conduit LOS C (S.U.E.*)	---TC---
U/G Telephone Conduit LOS D (S.U.E.*)	---TC---
U/G Fiber Optics Cable LOS B (S.U.E.*)	---T FO---
U/G Fiber Optics Cable LOS C (S.U.E.*)	---T FO---
U/G Fiber Optics Cable LOS D (S.U.E.*)	---T FO---

WATER:

Water Manhole	○ W
Water Meter	○
Water Valve	⊗
Water Hydrant	⊕
U/G Water Line LOS B (S.U.E.*)	---W---
U/G Water Line LOS C (S.U.E.*)	---W---
U/G Water Line LOS D (S.U.E.*)	---W---
Above Ground Water Line	---A/G Water---

TV:

TV Pedestal	□
TV Tower	⊗
U/G TV Cable Hand Hole	○
U/G TV Cable LOS B (S.U.E.*)	---TV---
U/G TV Cable LOS C (S.U.E.*)	---TV---
U/G TV Cable LOS D (S.U.E.*)	---TV---
U/G Fiber Optic Cable LOS B (S.U.E.*)	---TV FO---
U/G Fiber Optic Cable LOS C (S.U.E.*)	---TV FO---
U/G Fiber Optic Cable LOS D (S.U.E.*)	---TV FO---

GAS:

Gas Valve	◇
Gas Meter	⊕
U/G Gas Line LOS B (S.U.E.*)	---G---
U/G Gas Line LOS C (S.U.E.*)	---G---
U/G Gas Line LOS D (S.U.E.*)	---G---
Above Ground Gas Line	---A/G Gas---

SANITARY SEWER:

Sanitary Sewer Manhole	⊕
Sanitary Sewer Cleanout	⊕
U/G Sanitary Sewer Line	---SS---
Above Ground Sanitary Sewer	---A/G Sanitary Sewer---
SS Forced Main Line LOS B (S.U.E.*)	---FSS---
SS Forced Main Line LOS C (S.U.E.*)	---FSS---
SS Forced Main Line LOS D (S.U.E.*)	---FSS---

MISCELLANEOUS:

Utility Pole	●
Utility Pole with Base	□
Utility Located Object	○
Utility Traffic Signal Box	⊕
Utility Unknown U/G Line LOS B (S.U.E.*)	---UTL---
U/G Tank; Water, Gas, Oil	□
Underground Storage Tank, Approx. Loc.	⊕
A/G Tank; Water, Gas, Oil	□
Geoenvironmental Boring	⊕
U/G Test Hole LOS A (S.U.E.*)	○
Abandoned According to Utility Records	AATUR
End of Information	E.O.I.

PAVEMENT SCHEDULE

(PRELIMINARY PAVEMENT DESIGN)

C1	PROP. APPROX. 3" ASPHALT CONCRETE SURFACE COURSE TYPE S9.5C, AT AN AVERAGE RATE OF 168 LBS. PER SQ. YD. IN EACH OF TWO LAYERS.	R2	8"x12" CONCRETE CURB.
C2	PROP. APPROX. 1½" ASPHALT CONCRETE SURFACE COURSE, TYPE S9.5C, AT AN AVERAGE RATE OF 168 LBS. PER SQ. YD.	R3	SHOULDER BERM GUTTER.
C3	PROP. VAR. DEPTH ASPHALT CONCRETE SURFACE COURSE, TYPE S9.5C, AT AN AVERAGE RATE OF 112 LBS. PER SQ. YD. PER 1" DEPTH. TO BE PLACED IN LAYERS NOT TO EXCEED 2" IN DEPTH.	R4	5" CONCRETE MONOLITHIC ISLAND (KEYED-IN).
D1	PROP. APPROX. 3" ASPHALT CONCRETE INTERMEDIATE COURSE, TYPE I19.0C, AT AN AVERAGE RATE OF 342 LBS. PER SQ. YD.	R5	SINGLE FACED CONCRETE BARRIER.
D2	PROP. VAR. DEPTH ASPHALT CONCRETE INTERMEDIATE COURSE, TYPE I19.0C, AT AN AVERAGE RATE OF 114 LBS. PER SQ. YD. PER 1" DEPTH. TO BE PLACED IN LAYERS NOT LESS THAN 2½" IN DEPTH OR GREATER THAN 4" IN DEPTH.	T	EARTH MATERIAL.
E1	PROP. APPROX. 5½" ASPHALT CONCRETE BASE COURSE, TYPE B25.0C, AT AN AVERAGE RATE OF 627 LBS. PER SQ. YD.	U	EXISTING PAVEMENT.
E2	PROP. VAR. DEPTH ASPHALT CONCRETE BASE COURSE, TYPE B25.0C, AT AN AVERAGE RATE OF 114 LBS. PER SQ. YD. PER 1" DEPTH. TO BE PLACED IN LAYERS NOT LESS THAN 3" IN DEPTH OR GREATER THAN 5½" IN DEPTH.	V1	MILLING BITUMINOUS PAVEMENT. 3" DEPTH.
J1	PROP. 6" AGGREGATE BASE COURSE.	V2	MILLING BITUMINOUS PAVEMENT. 1½" DEPTH.
R1	2'-6" CONCRETE CURB AND GUTTER.	W	VARIABLE DEPTH ASPHALT PAVEMENT (SEE STANDARD WEDGING DETAIL)

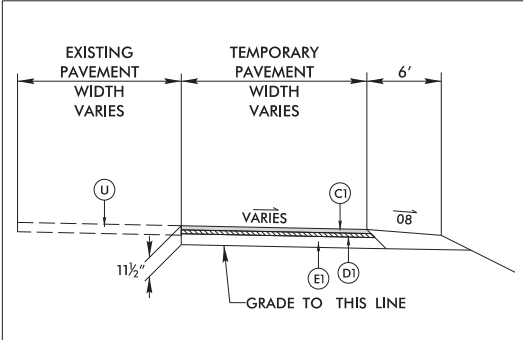

**DETAIL SHOWING
TEMPORARY PAVEMENT**

NOTE: PAVEMENT EDGE SLOPES ARE 1:1 UNLESS SHOWN OTHERWISE.

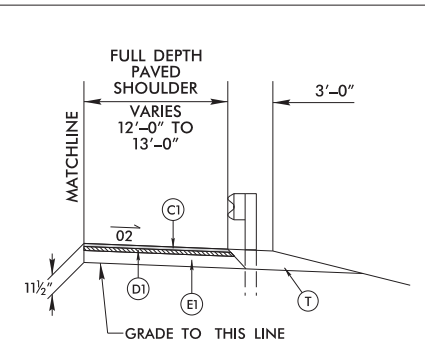

**DETAIL SHOWING PAVING TO
THE FACE OF GUARDRAIL**

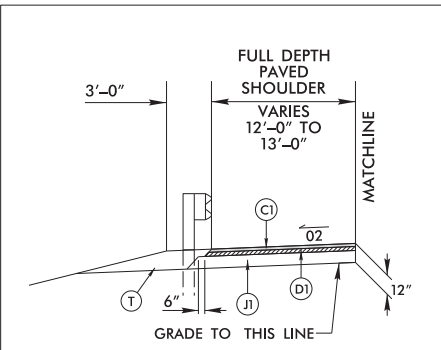

**DETAIL SHOWING PAVING TO
THE FACE OF GUARDRAIL**

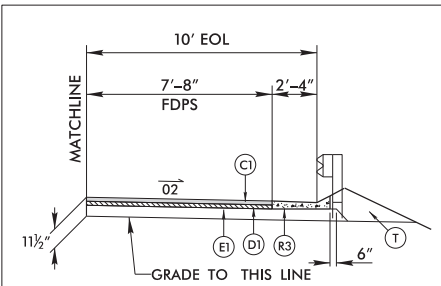

**DETAIL SHOWING GUARDRAIL WITH
SHOULDER BERM GUTTER**

USE SHOULDER BERM GUTTER AT THE FOLLOWING LOCATIONS:

- L- STA. 78+25.00 TO -L- STA. 84+94.00
- L- STA. 121+50.00 TO -L- STA. 128+30.00
- L- STA. 180+75.00 TO -L- STA. 187+30.00
- L- STA. 215+46.00 TO -L- STA. 226+44.00
- L- STA. 250+75.00 TO -L- STA. 258+05.00
- L- STA. 263+13.00 TO -L- STA. 267+50.00
- L- STA. 299+50.00 TO -L- STA. 304+00.00
- L- STA. 338+25.00 TO -L- STA. 348+52.00
- L- STA. 361+75.00 TO -L- STA. 368+80.00
- L- STA. 383+50.00 TO -L- STA. 385+02.00
- L- STA. 390+00.00 TO -L- STA. 399+64.00
- L- STA. 427+75.00 TO -L- STA. 429+00.00
- L- STA. 449+23.00 TO -L- STA. 452+28.13

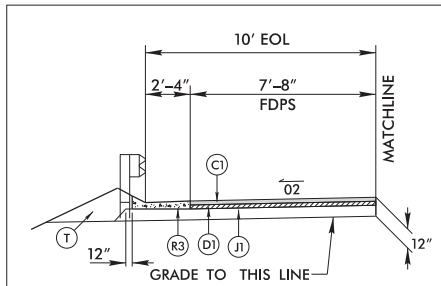

**DETAIL SHOWING GUARDRAIL WITH
SHOULDER BERM GUTTER**

USE SHOULDER BERM GUTTER AT THE FOLLOWING LOCATIONS:

- L- STA. 27+50.00 TO -L- STA. 32+63.00
- L- STA. 44+49.00 TO -L- STA. 55+66.00
- L- STA. 78+95.00 TO -L- STA. 86+25.00
- L- STA. 121+00.00 TO -L- STA. 128+30.00
- L- STA. 158+00.00 TO -L- STA. 170+17.00
- L- STA. 191+75.00 TO -L- STA. 196+93.00
- L- STA. 222+06.25 TO -L- STA. 226+25.00
- L- STA. 264+50.00 TO -L- STA. 270+25.00
- L- STA. 300+46.00 TO -L- STA. 306+12.00
- L- STA. 344+56.00 TO -L- STA. 350+29.00
- L- STA. 383+56.00 TO -L- STA. 396+25.00
- L- STA. 449+00.00 TO -L- STA. 451+50.00

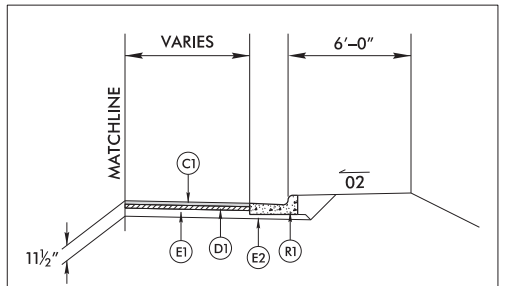

**DETAIL SHOWING PAVING TO
2'-6" CURB AND GUTTER**

- L- STA. 31+62.36 TO -L- STA. 33+68.14
- Y1A- STA. 11+03.27 TO -Y1A- STA. 12+96.30

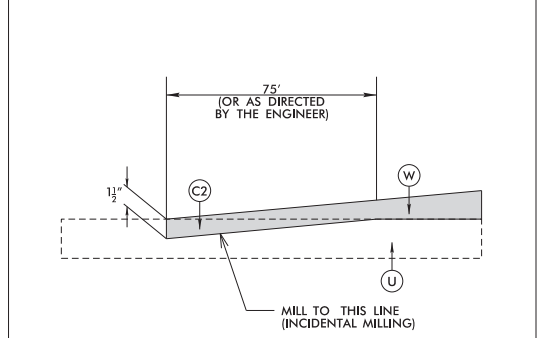

**DETAIL SHOWING MILLED
PAVEMENT PROFILE TIE-IN**

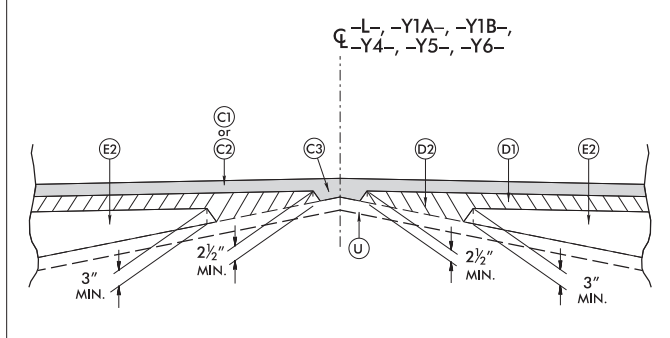

DETAIL SHOWING METHOD OF WEDGING

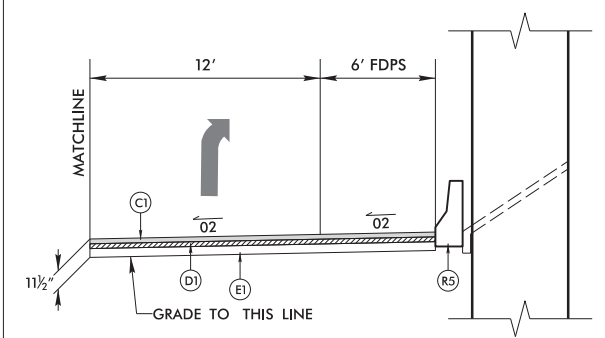

**DETAIL SHOWING PAVING TO
THE FACE OF BARRIER**

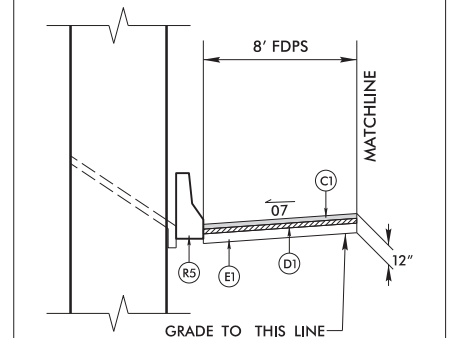

**DETAIL SHOWING PAVING TO
THE FACE OF BARRIER**

REVISIONS

5/14/99

2/2/2019 10:20:00 AM \\P:\proj\2527\RDY_TYP.dgn

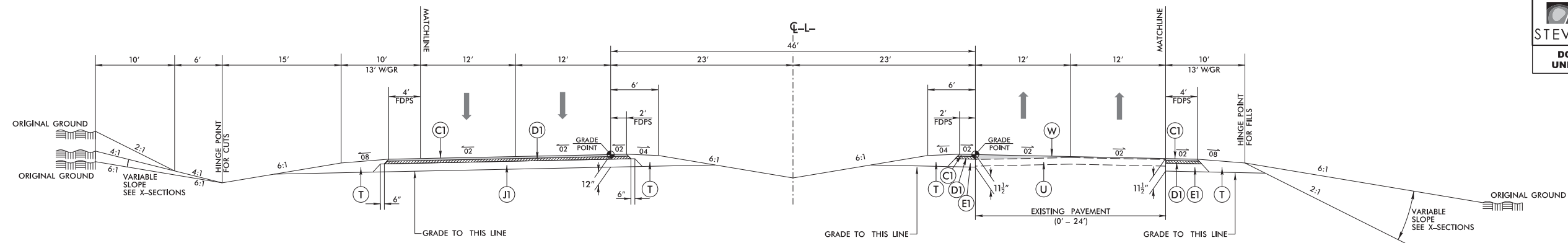

TYPICAL SECTION NO. 1
 -L- STA. 16+50.00 TO STA. 375+00.00
 -L- STA. 406+50.00 TO STA. 418+00.00
 -L- STA. 422+00.00 TO STA. 424+50.00
 -L- STA. 426+50.00 TO STA. 434+00.00
 -L- STA. 442+00.00 TO STA. 445+00.00

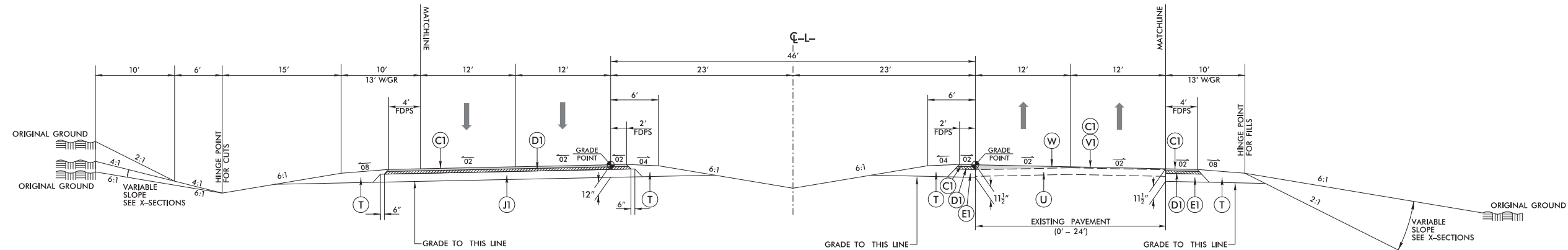

TYPICAL SECTION NO. 2
 -L- STA. 375+00.00 TO STA. 392+00.00
 -L- STA. 418+00.00 TO STA. 422+00.00
 -L- STA. 434+00.00 TO STA. 442+00.00

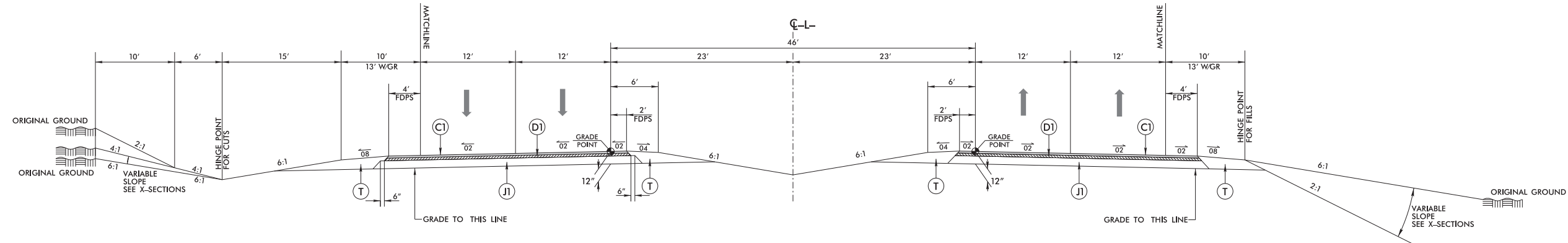

TYPICAL SECTION NO. 3
 -L- STA. 392+00.00 TO STA. 406+50.00
 -L- STA. 424+50.00 TO STA. 426+50.00
 -L- STA. 445+50.00 TO STA. 452+28.13

PAVEMENT SCHEDULE (PRELIMINARY PAVEMENT DESIGN)	
C1	3" S9.5C
C2	1½" S9.5C
C3	VAR. S9.5C
D1	3" I19.0C
D2	VAR. I19.0C
E1	5½" B25.0C
E2	VAR. B25.0C
J1	6" ABC
R1	2'-6" C & G
R2	8"x12" CURB
R3	SHOULDER BERM GUTTER
R4	5" CONCRETE MONOLITHIC ISLAND
R5	SINGLE FACED CONCRETE BARRIER
T	EARTH MATERIAL
U	EXIST. PAVEMENT
V1	3" MILLING
V2	1½" MILLING
W	WEDGING

NOTE: PAVEMENT EDGE SLOPES ARE 1:1 UNLESS SHOWN OTHERWISE.

REVISIONS

5/14/99

2/2/2019
 I:\Projects\2019\Projects\R2527\RDY_TYP.dgn
 I:\Projects\2019\Projects\R2527\RDY.dgn



DOCUMENT NOT CONSIDERED FINAL UNLESS ALL SIGNATURES COMPLETED

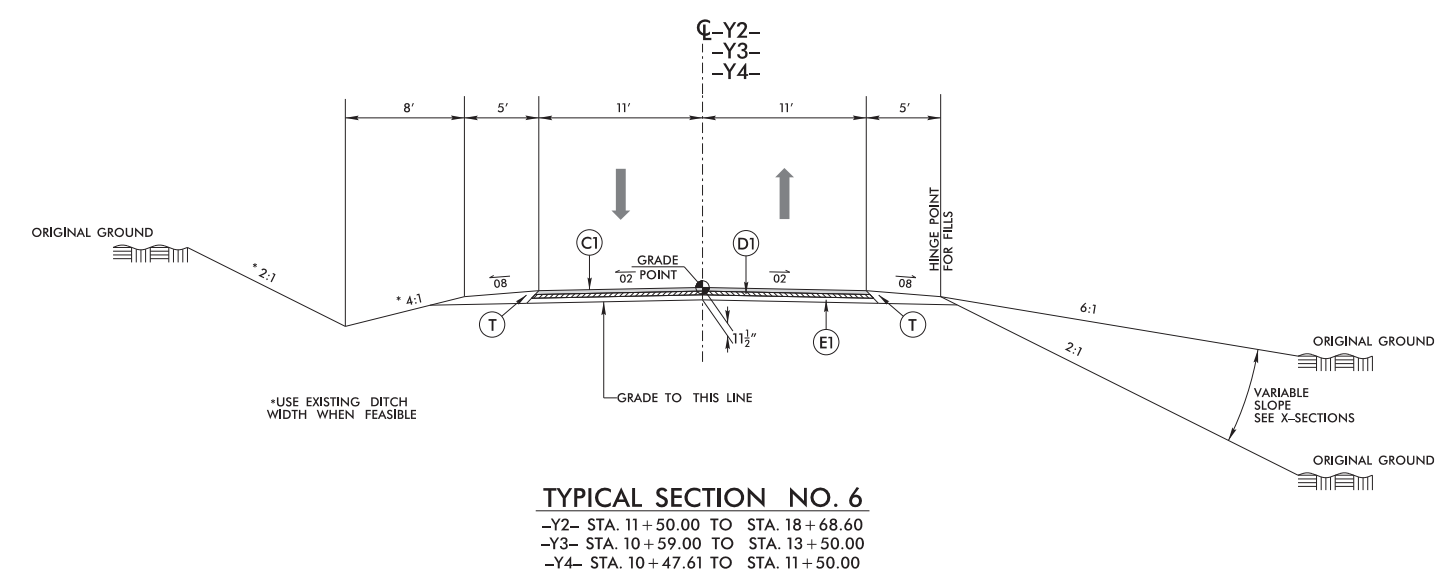
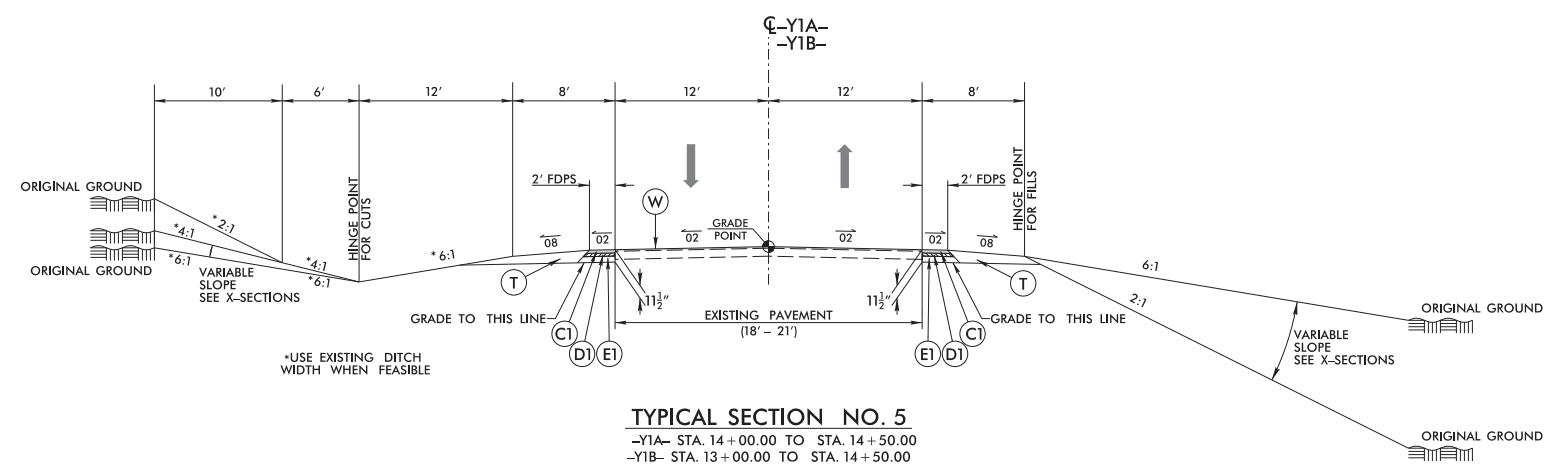
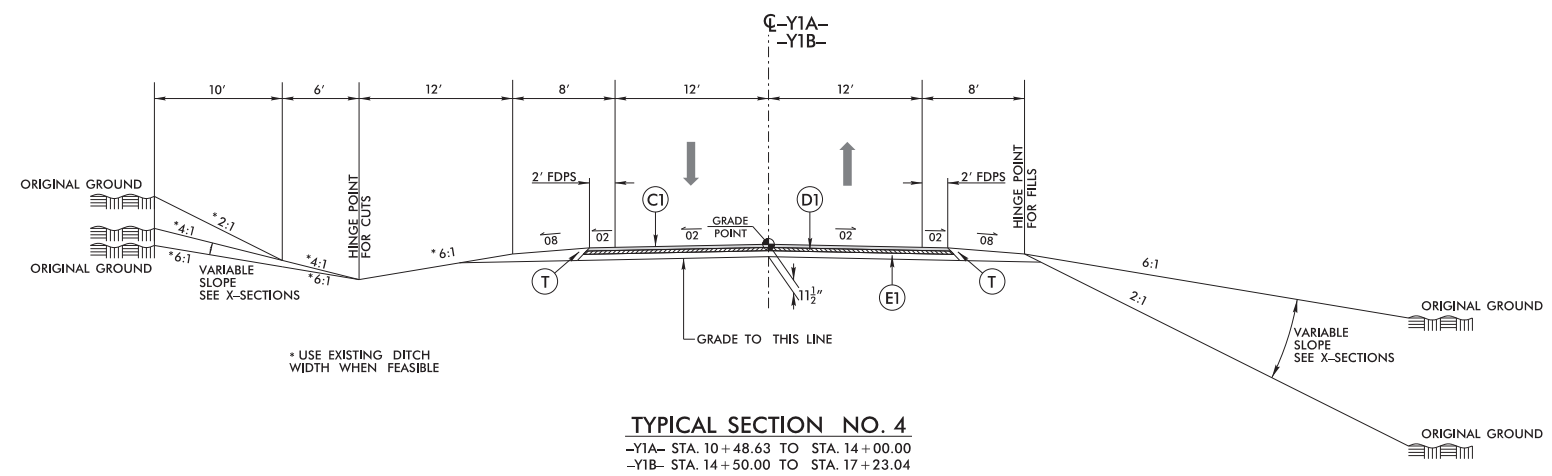

PAVEMENT SCHEDULE
(PRELIMINARY PAVEMENT DESIGN)

C1	3" S9.5C
C2	1 1/2" S9.5C
C3	VAR. S9.5C
D1	3" I19.0C
D2	VAR. I19.0C
E1	5 1/2" B25.0C
E2	VAR. B25.0C
J1	6" ABC
R1	2'-6" C & G
R2	8" x 12" CURB
R3	SHOULDER BERM GUTTER
R4	5" CONCRETE MONOLITHIC ISLAND
R5	SINGLE FACED CONCRETE BARRIER
T	EARTH MATERIAL
U	EXIST. PAVEMENT
V1	3" MILLING
V2	1 1/2" MILLING
W	WEDGING

NOTE: PAVEMENT EDGE SLOPES ARE 1:1 UNLESS SHOWN OTHERWISE.

REVISIONS

5/14/99

REVISIONS

PROJECT REFERENCE NO. <i>R-2527</i>	SHEET NO. <i>2A-4</i>
ROADWAY DESIGN ENGINEER	PAVEMENT DESIGN ENGINEER
 <small> Firm License No. C-2527 223 S. West St. Suite 1100 Raleigh, NC 27603 P. 919.386.0700 www.stewartinc.com </small>	
DOCUMENT NOT CONSIDERED FINAL UNLESS ALL SIGNATURES COMPLETED	

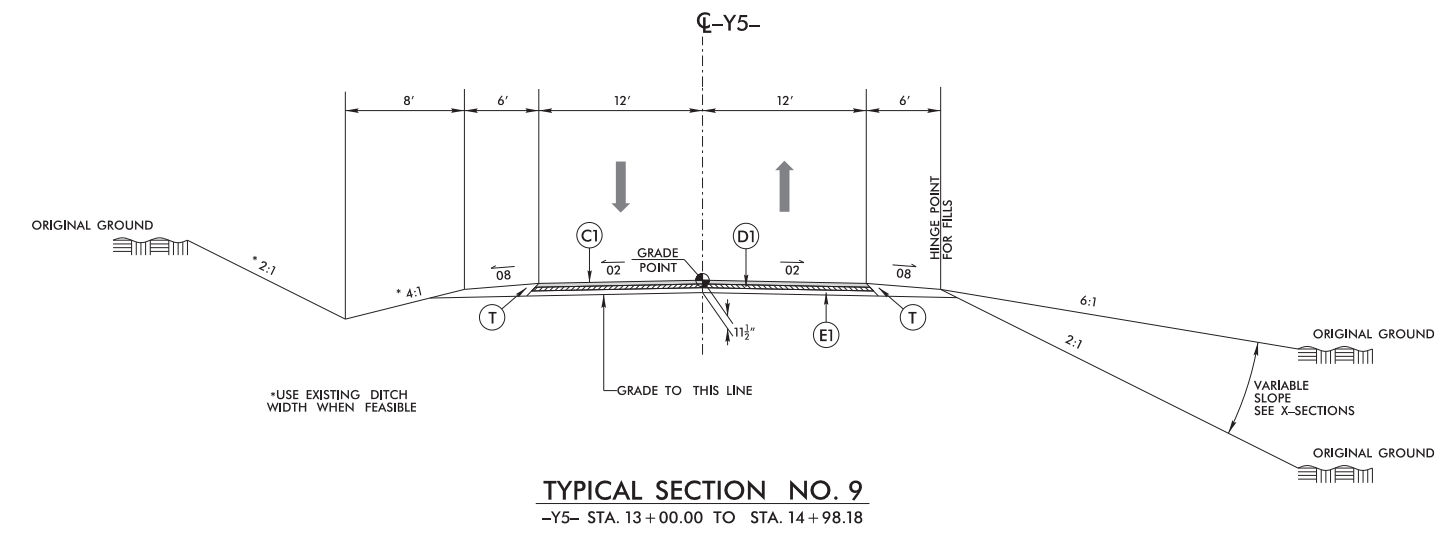
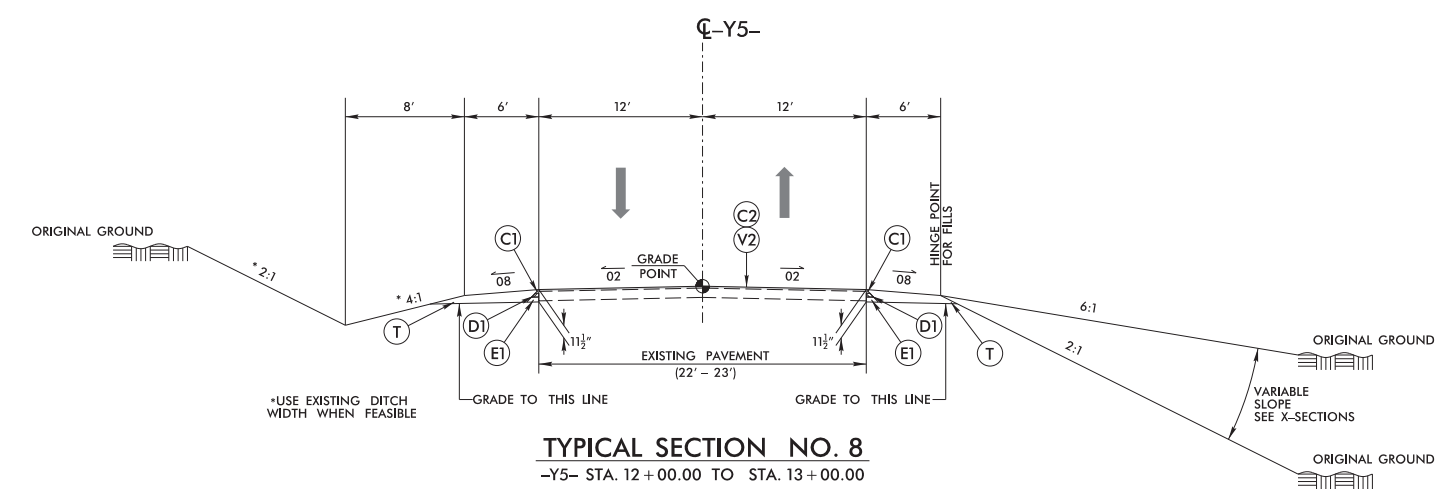
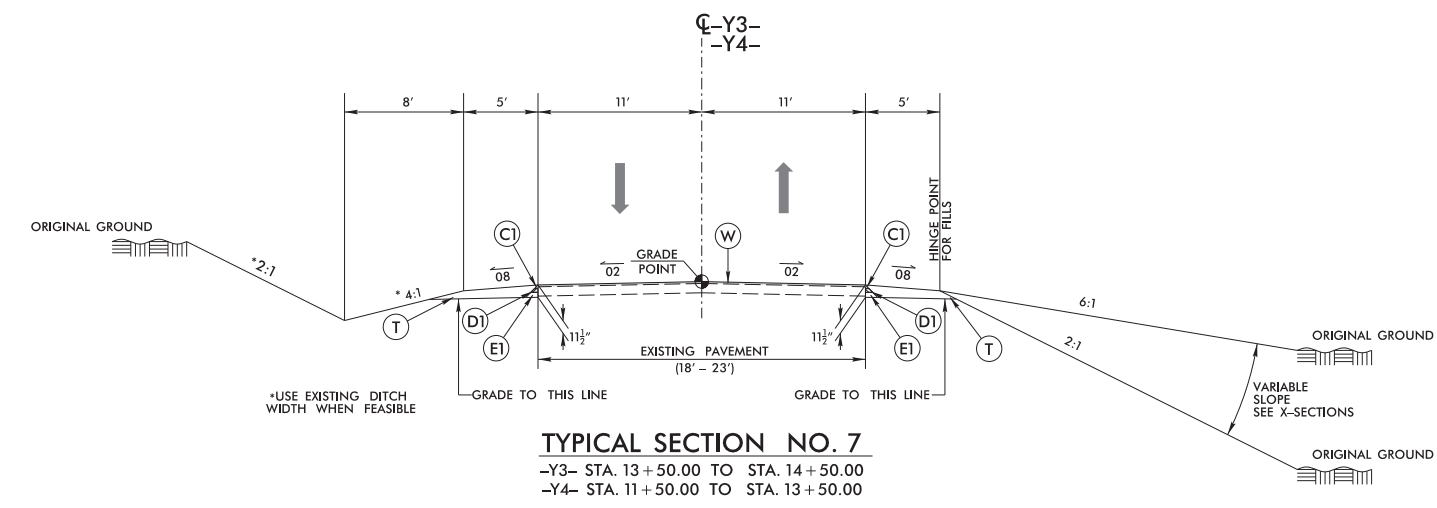

PAVEMENT SCHEDULE (PRELIMINARY PAVEMENT DESIGN)	
C1	3" S9.5C
C2	1½" S9.5C
C3	VAR. S9.5C
D1	3" I19.0C
D2	VAR. I19.0C
E1	5½" B25.0C
E2	VAR. B25.0C
J1	6" ABC
R1	2'-6" C & G
R2	8"x12" CURB
R3	SHOULDER BERM GUTTER
R4	5" CONCRETE MONOLITHIC ISLAND
R5	SINGLE FACED CONCRETE BARRIER
T	EARTH MATERIAL
U	EXIST. PAVEMENT
V1	3" MILLING
V2	1½" MILLING
W	WEDGING

NOTE: PAVEMENT EDGE SLOPES ARE 1:1 UNLESS SHOWN OTHERWISE.

2/2/2019
 C:\Users\j\OneDrive\Documents\Projects\R2527\RDY_TYP.dgn
 JUS

5/14/99

REVISIONS

2/14/2019
 C:\Users\j\OneDrive\Documents\Projects\RDY_TYP.dgn
 JUS

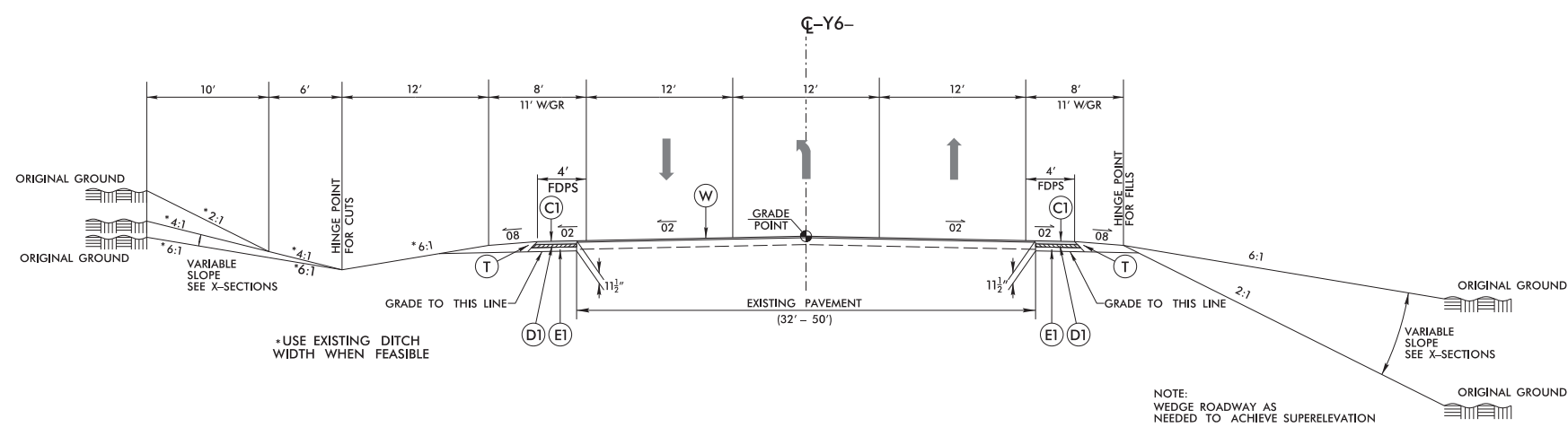
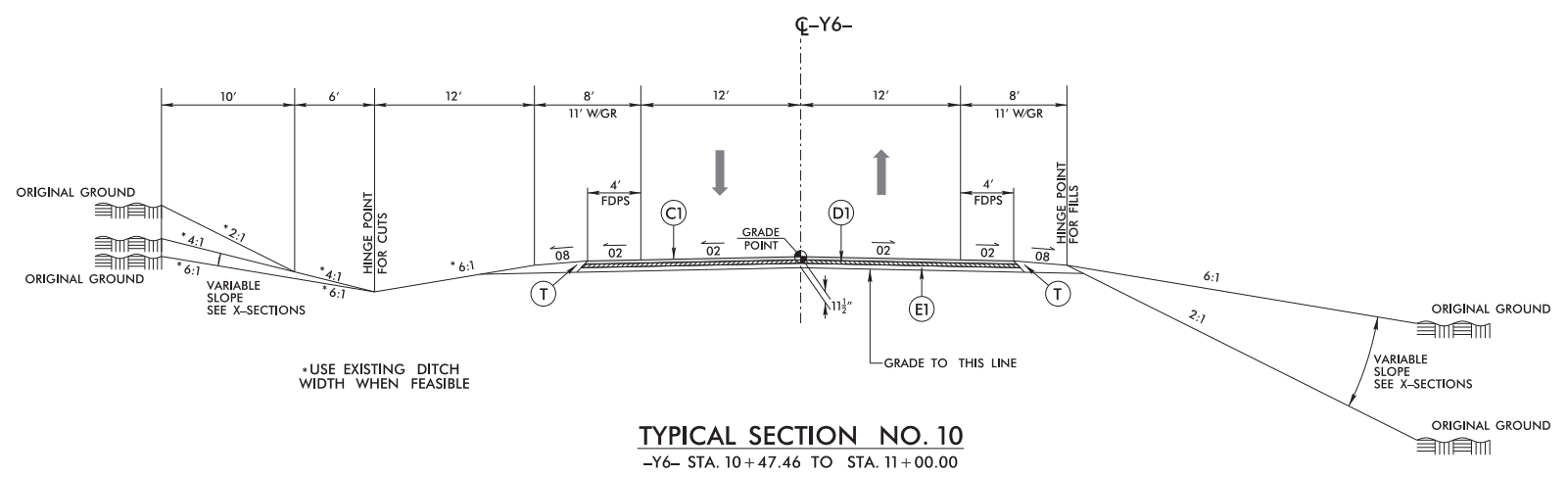

PROJECT REFERENCE NO. <i>R-2527</i>	SHEET NO. <i>2A-5</i>
ROADWAY DESIGN ENGINEER	PAVEMENT DESIGN ENGINEER
 <small>Firm License No. C-2527 223 S. West St. Suite 1100 Raleigh, NC 27603 P. 919.386.0799 www.stewartinc.com</small>	
DOCUMENT NOT CONSIDERED FINAL UNLESS ALL SIGNATURES COMPLETED	



PAVEMENT SCHEDULE (PRELIMINARY PAVEMENT DESIGN)	
C1	3" S9.5C
C2	1½" S9.5C
C3	VAR. S9.5C
D1	3" I19.0C
D2	VAR. I19.0C
E1	5½" B25.0C
E2	VAR. B25.0C
J1	6" ABC
R1	2'-6" C & G
R2	8"x12" CURB
R3	SHOULDER BERM GUTTER
R4	5" CONCRETE MONOLITHIC ISLAND
R5	SINGLE FACED CONCRETE BARRIER
T	EARTH MATERIAL
U	EXIST. PAVEMENT
V1	3" MILLING
V2	1½" MILLING
W	WEDGING

NOTE: PAVEMENT EDGE SLOPES ARE 1:1 UNLESS SHOWN OTHERWISE.

5/14/99

PROJECT REFERENCE NO. R-2527	SHEET NO. 4
ROADWAY DESIGN ENGINEER	HYDRAULICS ENGINEER
	
<small>STEWART 10000 Old Forest Road Raleigh, NC 27617 www.stewartinc.com</small>	
<small>vhb VHB Engineering NC, P.C. (C-3705) 940 Main Campus Drive, Suite 500 Raleigh, NC 27606</small>	

**DOCUMENT NOT CONSIDERED FINAL
UNLESS ALL SIGNATURES COMPLETED**

REVISIONS

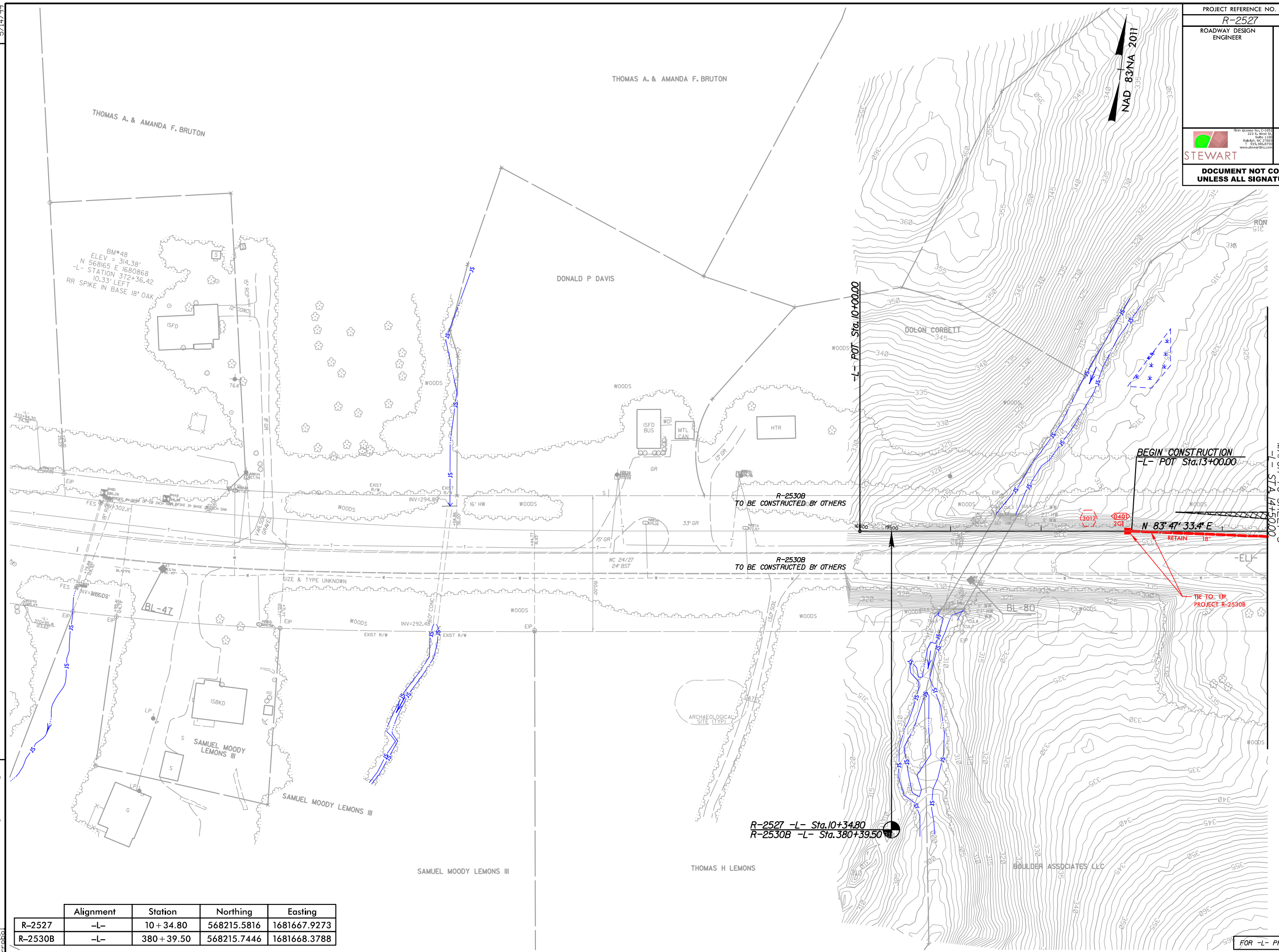

	Alignment	Station	Northing	Easting
R-2527	-L-	10 + 34.80	568215.5816	1681667.9273
R-2530B	-L-	380 + 39.50	568215.7446	1681668.3788

R:\3134 AM
R-2527\Drawings\CADD\PSH\R2527_Hyd_PSH04.dgn
P. Shob

MATCH TO SHEET 5
-L- STA. 14+50.00

BEGIN CONSTRUCTION
-L- POT Sta. 13+00.00

R-2530B
TO BE CONSTRUCTED BY OTHERS

R-2530B
TO BE CONSTRUCTED BY OTHERS

R-2527 -L- Sta. 10+34.80
R-2530B -L- Sta. 380+39.50

N 83° 47' 33.4" E
RETAIN 18"

TIE TO TIP
PROJECT R-2530B

FOR -L- PROFILE, SEE SHEET 42

5/14/99
8:36:40 AM
R:\Projects\cadd\PSHAR2527_Hyd_PSH05.dgn

Pls Sta 23+46.38
s = 1'56" 08.4"
Ls = 200.00'
LT = 133.34'
ST = 66.67'

Pls Sta 32+33.86
 $\Delta = 30' 59" 51.8" (LT)$
D = 1'56" 08.4"
L = 160.40'
T = 820.82'
R = 2,960.00'
S_o = 5%

Pls Sta 40+81.11
 $\Theta_s = 1'56" 08.4"$
Ls = 200.00'
LT = 133.34'
ST = 66.67'

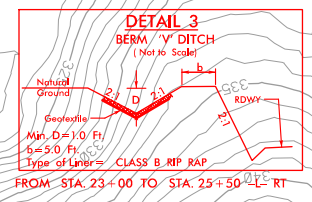

PROJECT REFERENCE NO. R-2527	SHEET NO. 5
ROADWAY DESIGN ENGINEER	HYDRAULICS ENGINEER
INCOMPLETE PLANS DO NOT USE FOR R/W ACQUISITION	
 STEWART	 vhb VHB Engineering NC, P.C. (C-3705) 140 Main Campus Drive, Suite 500 Raleigh, NC 27608
DOCUMENT NOT CONSIDERED FINAL UNLESS ALL SIGNATURES COMPLETED	

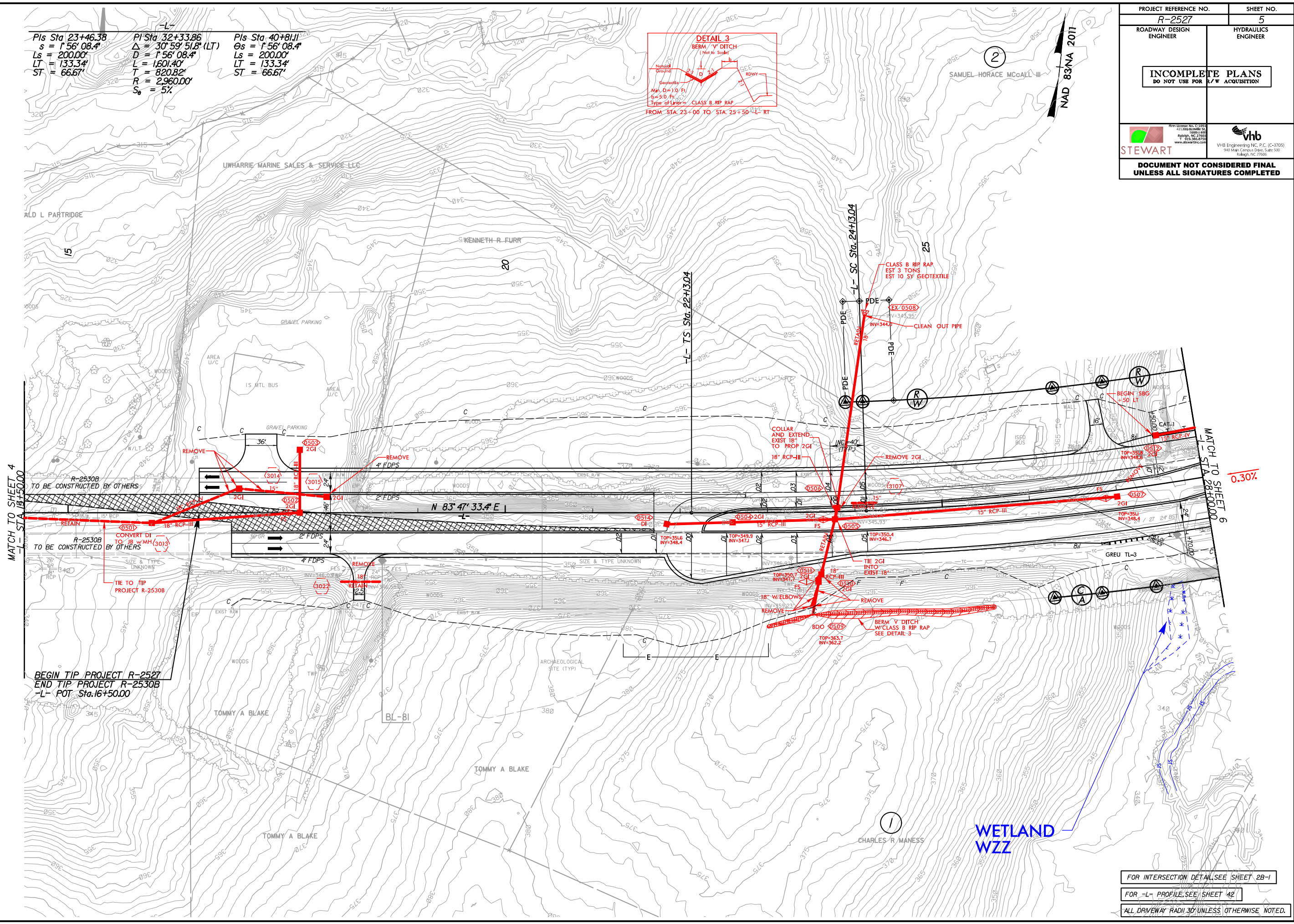

FOR INTERSECTION DETAIL SEE SHEET 2B-1
FOR -L- PROFILE SEE SHEET 42
ALL DRIVEWAY RADII 30' UNLESS OTHERWISE NOTED.

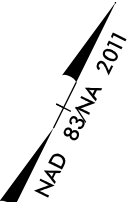

REVISIONS
ROW REV. - April 4, 2019 - PUE added along Parcels 2,3,6,8,49,DUE revised along Parcel 5, PUE revised along Parcel 5, PUE revised along Parcels 5,7,(MSB)
TCE removed along Parcels 6,7,(MSB)
ROW REV. - May 20, 2019 - ROW label added at -YIA- +00.00, 65.04 LT.(MSB)

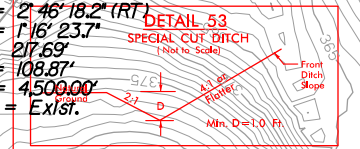
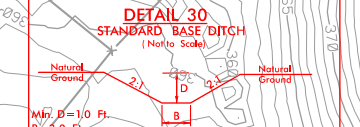
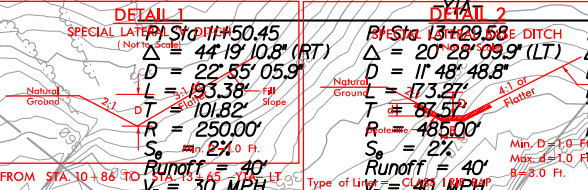
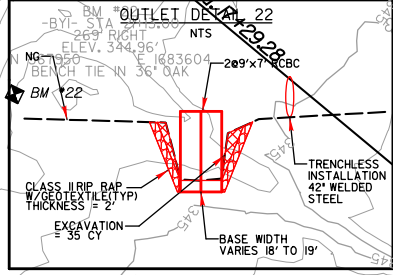
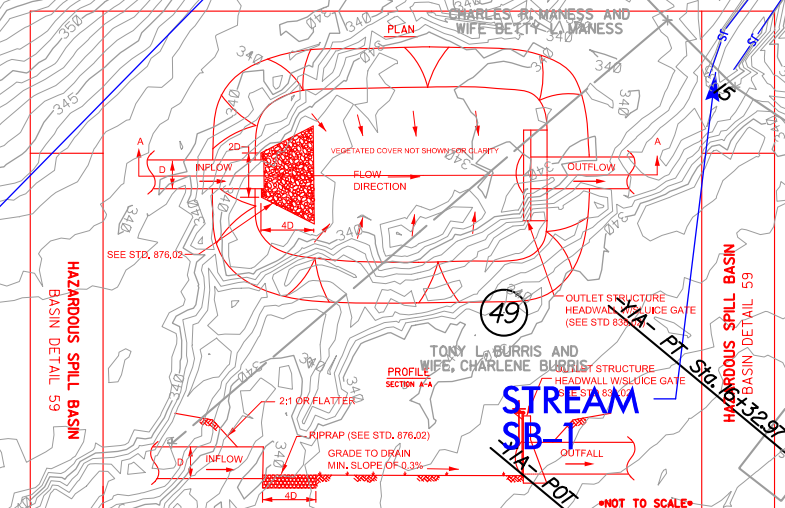
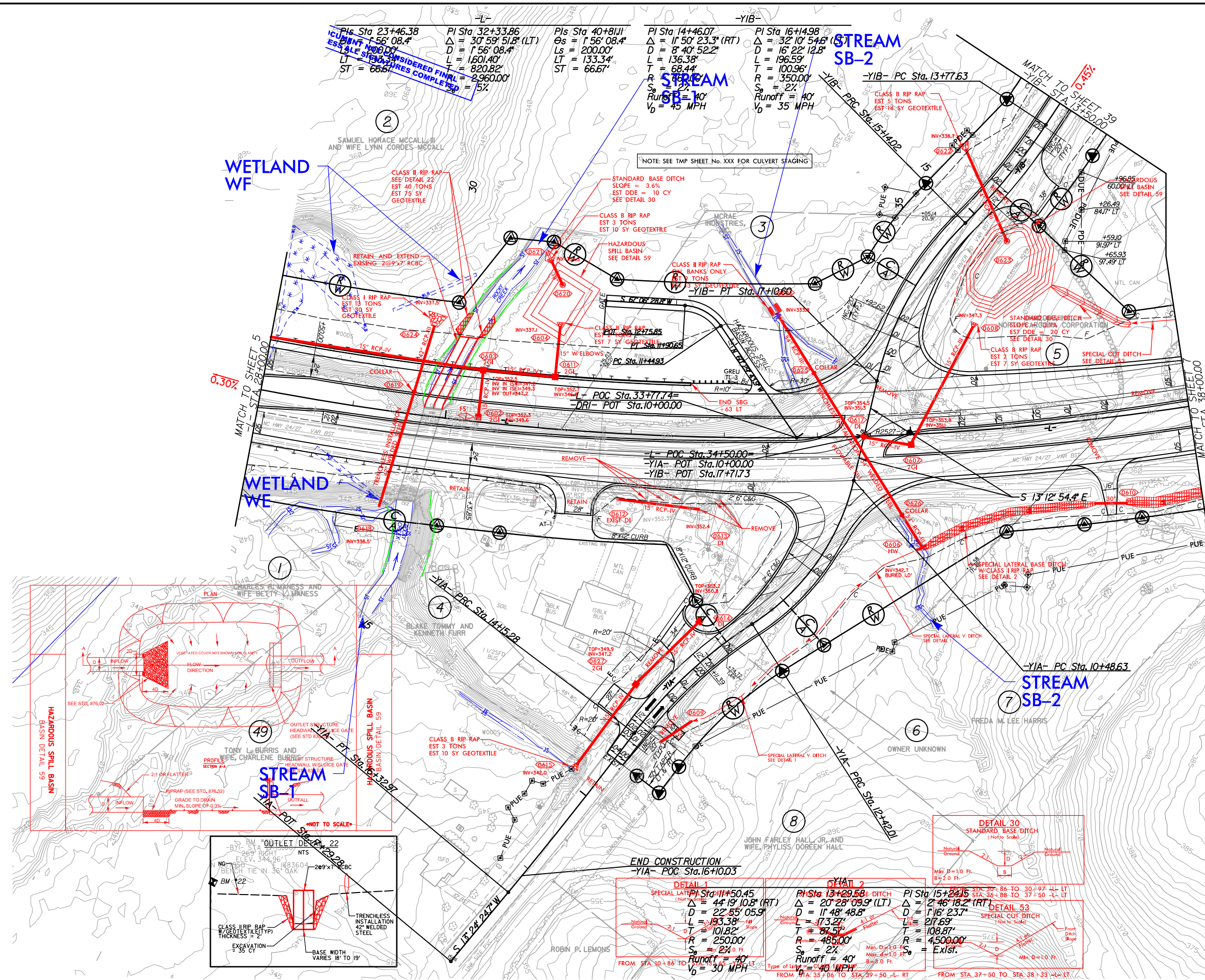

FOR INTERSECTION DETAIL, SEE SHEET 2B-2
FOR -L- PROFILE, SEE SHEET 42
FOR -YIA- PROFILE, SEE SHEET 58
FOR -YIB- PROFILE, SEE SHEET 58
ALL DRIVEWAY RADII 30' UNLESS OTHERWISE NOTED.

$Pis Sta 23+46.38$
 $\Delta s = 1'56.08.4"$
 $Ls = 200.00'$
 $LT = 133.34'$
 $ST = 66.67'$

$PI Sta 32+33.86$
 $\Delta = 30'59.51.8" (LT)$
 $D = 1'56.08.4"$
 $L = 160.40'$
 $T = 820.82'$
 $R = 2960.00'$
 $S_0 = -5\%$

$Pis Sta 40+81.11$
 $\Delta s = 1'56.08.4"$
 $Ls = 200.00'$
 $LT = 133.34'$
 $ST = 66.67'$



REVISIONS
 ROW REV. - April 4, 2019 - PUE added along Parcel 12 and 13, PUE revised along Parcel 7, TCE revised along Parcel 12, (MSB)
 PUE removed along Parcels 5 and 9, TCE removed along Parcel 12, (MSB)
 ROW REV. - May 20, 2019 - ROW label added at -L- +48.58, 10.61 RT, (MSB)

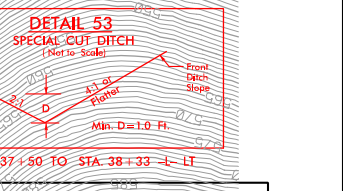
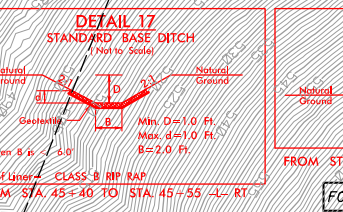
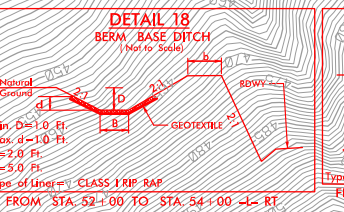
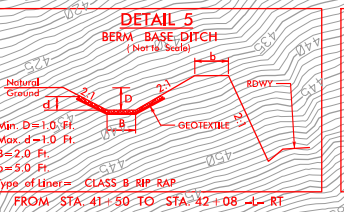
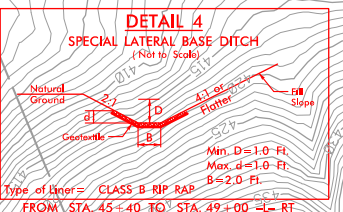
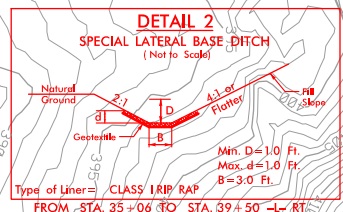
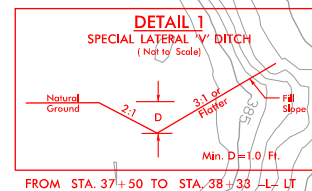
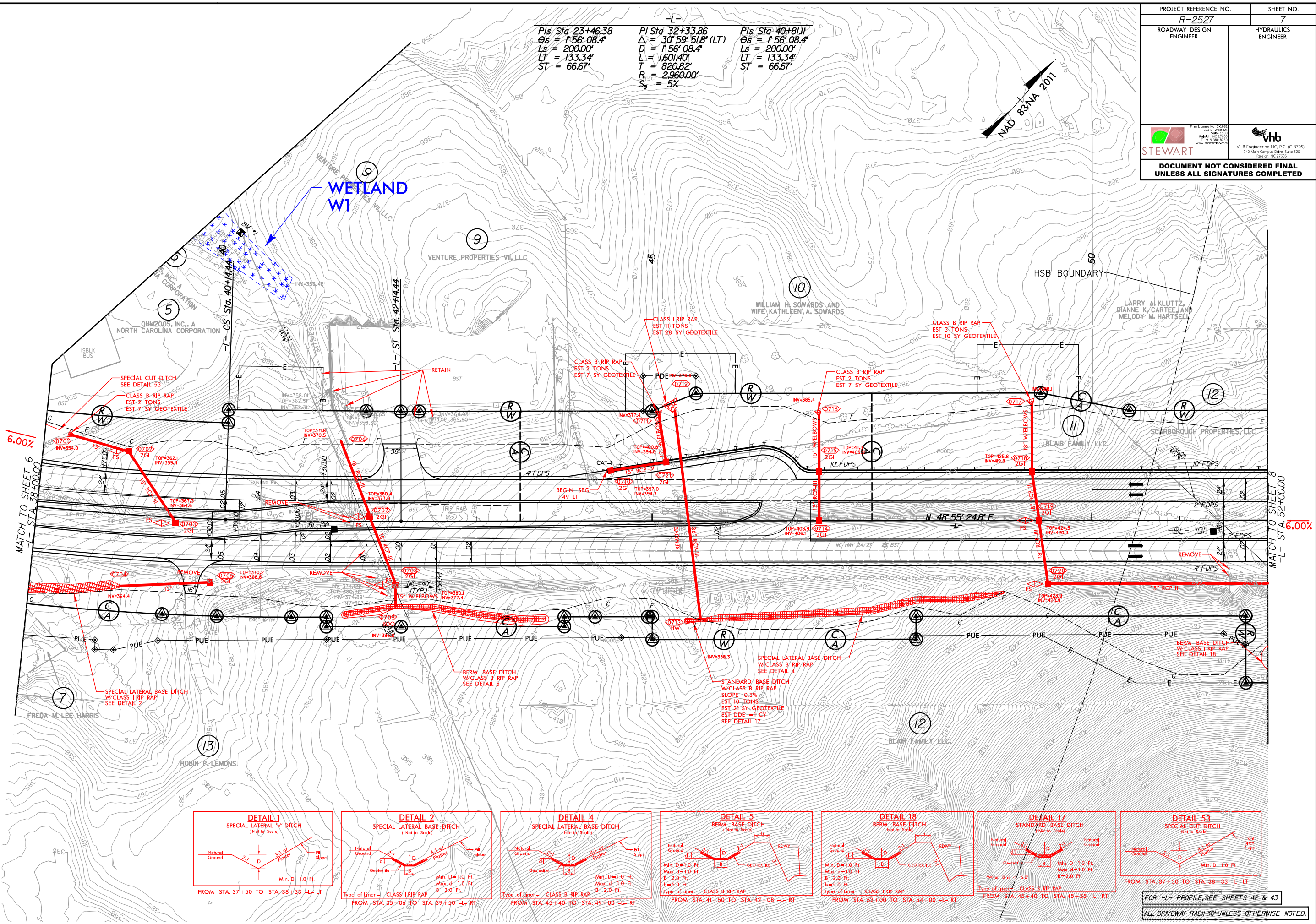

FOR -L- PROFILE, SEE SHEETS 42 & 43
ALL DRIVEWAY RADII 30' UNLESS OTHERWISE NOTED.

B:\154531\154531.dwg
 B:\154531\154531.dwg
 B:\154531\154531.dwg

Pls Sta 57+79.80
 $\theta_s = 6'12''54.5''$
 $L_s = 320.00'$
 $LT = 213.46'$
 $ST = 106.79'$

Pls Sta 68+03.13
 $\Delta = 63'43''36.5'' (RT)$
 $D = 3'53''04.1''$
 $L = 1640.56'$
 $T = 916.80'$
 $R = 1475.00'$
 $S_p = 8\%$

Pls Sta 76+33.68
 $\theta_s = 6'12''54.5''$
 $L_s = 320.00'$
 $LT = 213.46'$
 $ST = 106.79'$

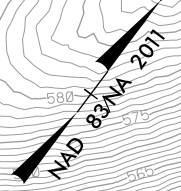
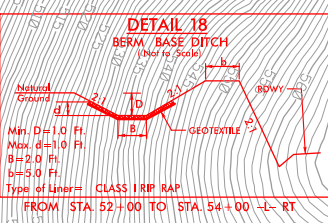
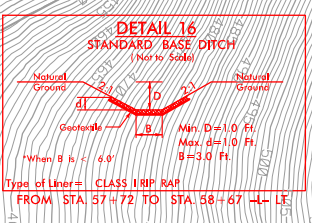
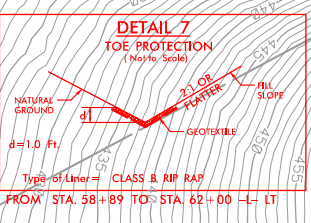
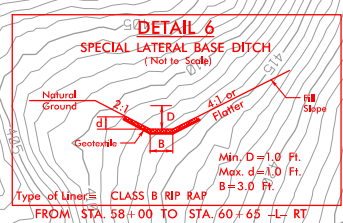

REVISIONS
 ROW REV. - April 4, 2019 - DUE revised along Parcel 12, PUE revised along Parcel 12, TCE revised along Parcel 12, (MSB)

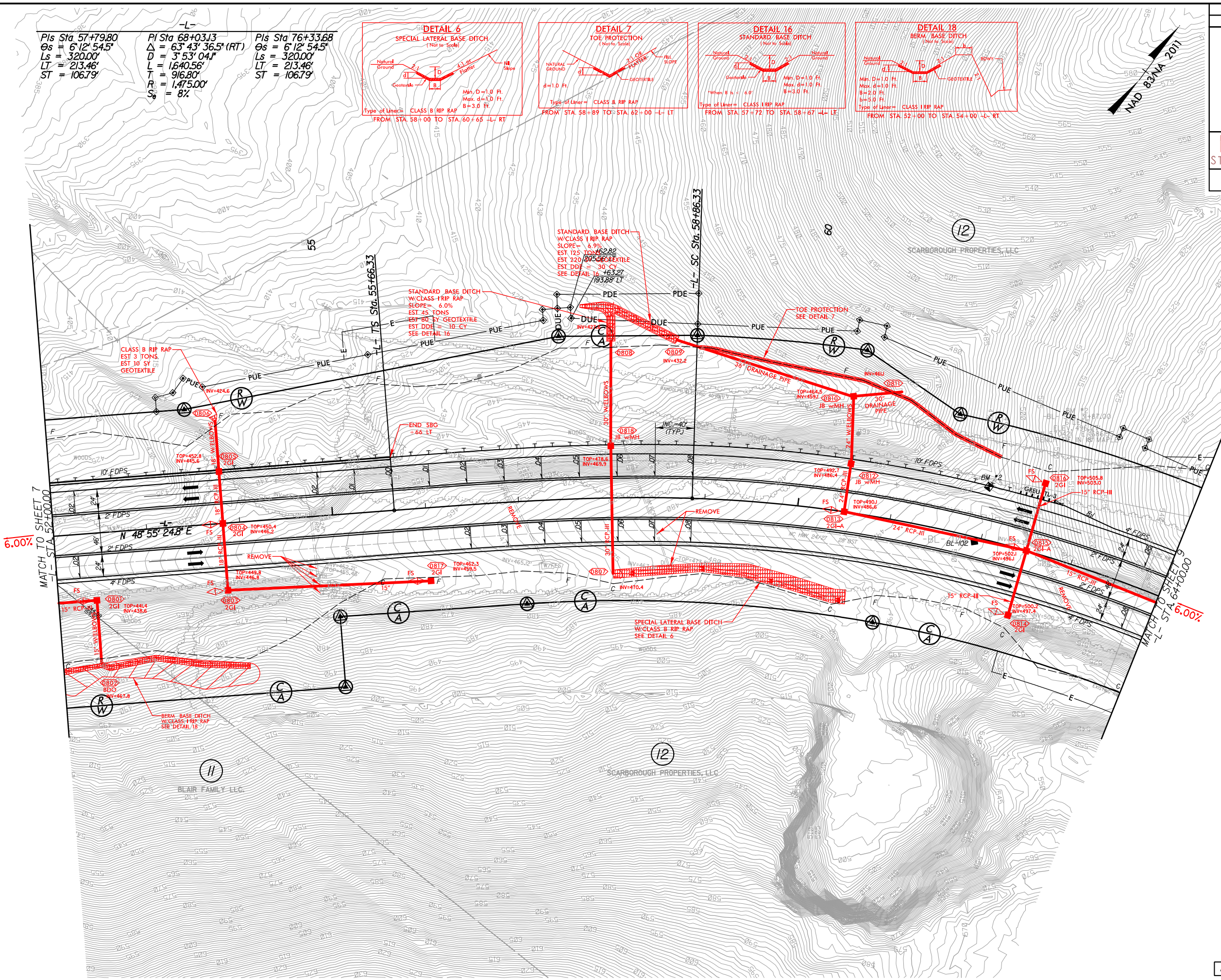

8:37:06 AM
 R:\Projects\2527\CADD\PSH\R2527_Hyd_PSH08.dgn

5/14/99

-L-

PIs Sta 57+79.80	PI Sta 68+03.13	PIs Sta 76+33.68
$\Delta s = 6'12''54.5''$	$\Delta = 6'3'43''36.5''$ (RT)	$\Delta s = 6'12''54.5''$
$Ls = 320.00'$	$D = 3'53''04.1''$	$Ls = 320.00'$
$LT = 213.46'$	$L = 1640.56'$	$LT = 213.46'$
$ST = 106.79'$	$T = 916.80'$	$ST = 106.79'$
	$R = 1,475.00'$	
	$S_c = 8\%$	

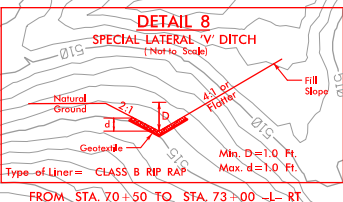
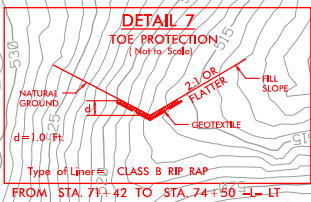
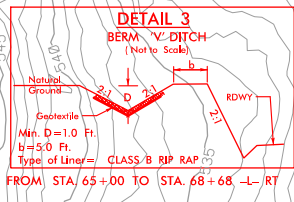

PROJECT REFERENCE NO. R-2527	SHEET NO. 9
ROADWAY DESIGN ENGINEER	HYDRAULICS ENGINEER
DOCUMENT NOT CONSIDERED FINAL UNLESS ALL SIGNATURES COMPLETED	

REVISIONS
 ROW REV. - April 4, 2019 - PUE revised along Parcels 12 and 14. TCE revised along Parcel 12. (MSB)

8:37:12 AM
 R:\Projects\2527\2527_Hyd_PSH09.dgn
 P:\09

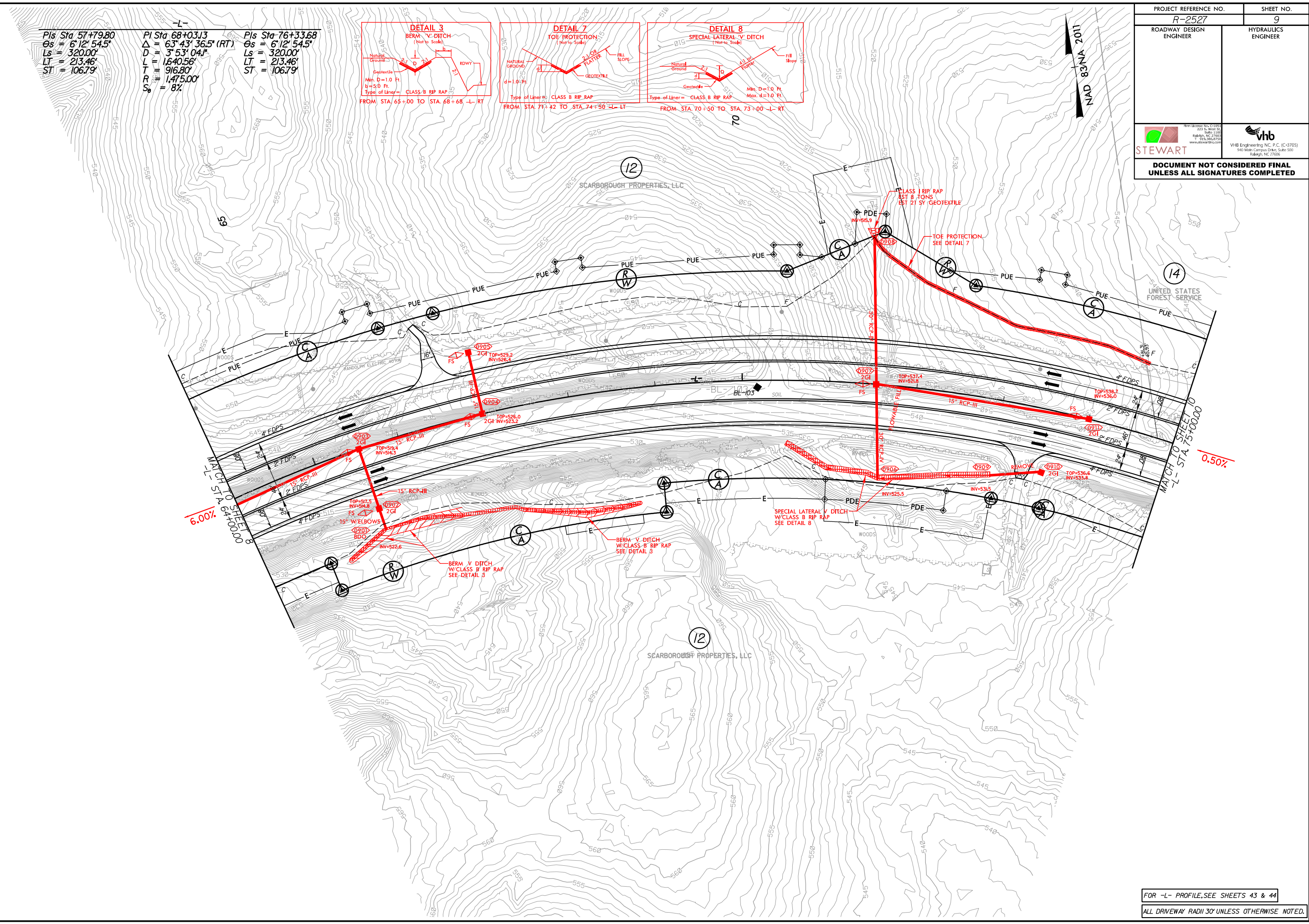

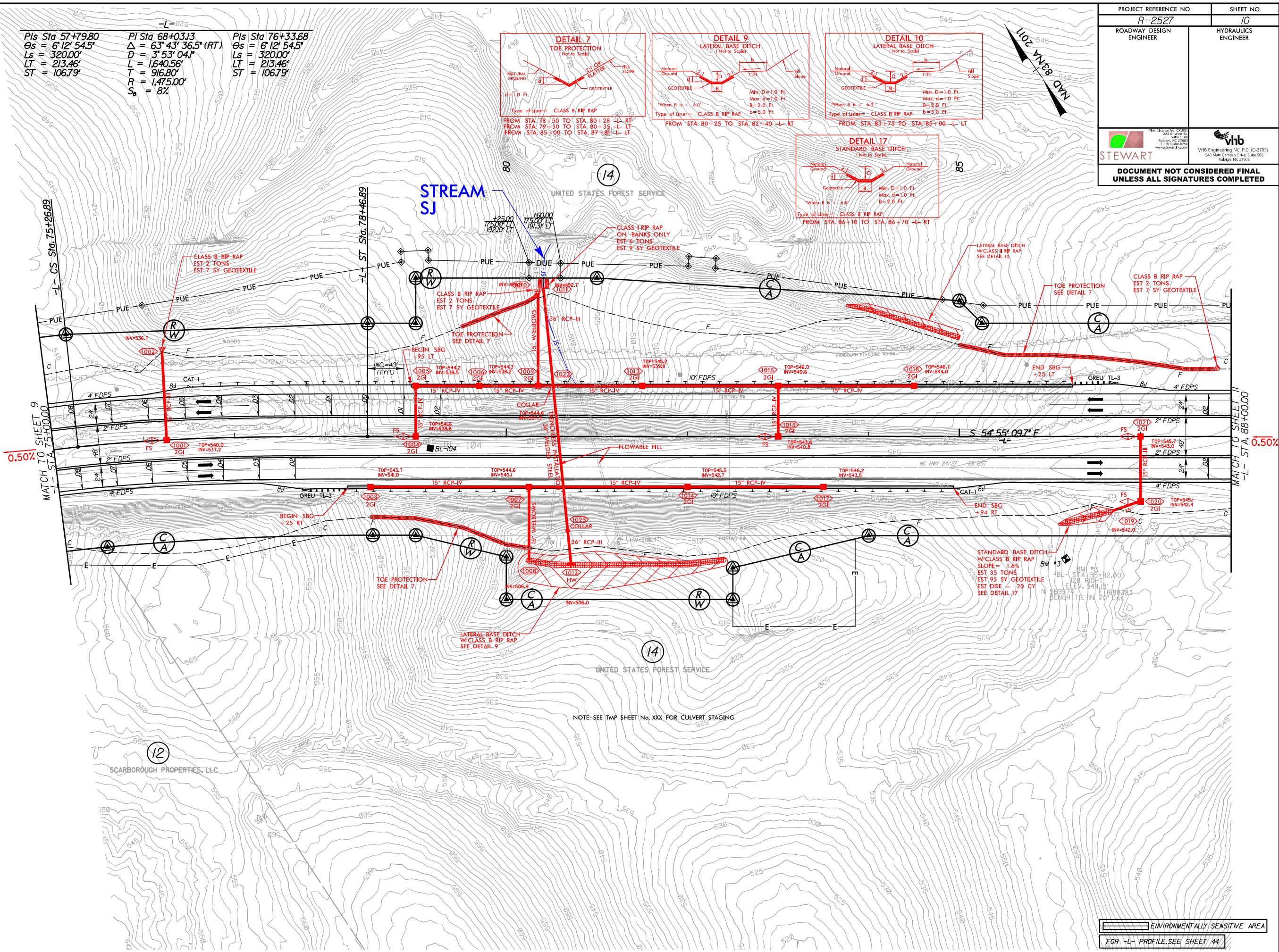
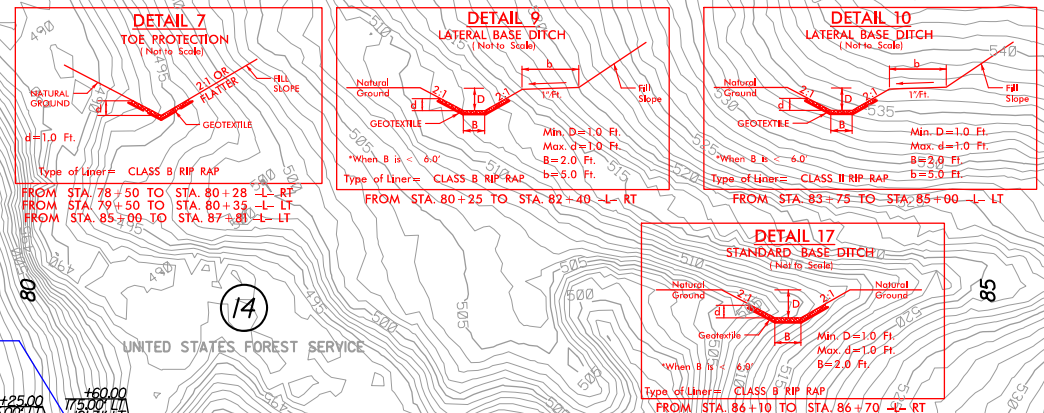

FOR -L- PROFILE, SEE SHEETS 43 & 44
 ALL DRIVEWAY RADII 30' UNLESS OTHERWISE NOTED.

$-L-02g$
 Pls Sta 57+79.80 PI Sta 68+03.13 Pls Sta 76+33.68
 $\Theta_s = 6' 12' 54.5''$ $\Delta = 63' 43' 36.5''$ (RT) $\Theta_s = 6' 12' 54.5''$
 $L_s = 320.00'$ $D = 3' 53' 04.1''$ $L_s = 320.00'$
 $LT = 213.46'$ $L = 1,640.56'$ $LT = 213.46'$
 $ST = 106.79'$ $T = 916.80'$ $ST = 106.79'$
 $R = 1,475.00'$ $S_o = 8\%$



REVISIONS
 ROW REV. - April 4, 2019 - DUE revised along Parcel 14, PUE revised along Parcel 14, (MSB)

R:\Projects\2527\CADD\PSH\R2527_Hyd_PSH10.dgn
 8:37:18 AM
 5/14/19

PROJECT REFERENCE NO. R-2527	SHEET NO. 11
ROADWAY DESIGN ENGINEER	HYDRAULICS ENGINEER
 Stewart Engineering, Inc. 223 S. West St. Raleigh, NC 27601 www.stewartinc.com	 VHB Engineering, P.C. (C-3705) 940 Map Campus Drive, Suite 500 Raleigh, NC 27605
DOCUMENT NOT CONSIDERED FINAL UNLESS ALL SIGNATURES COMPLETED	

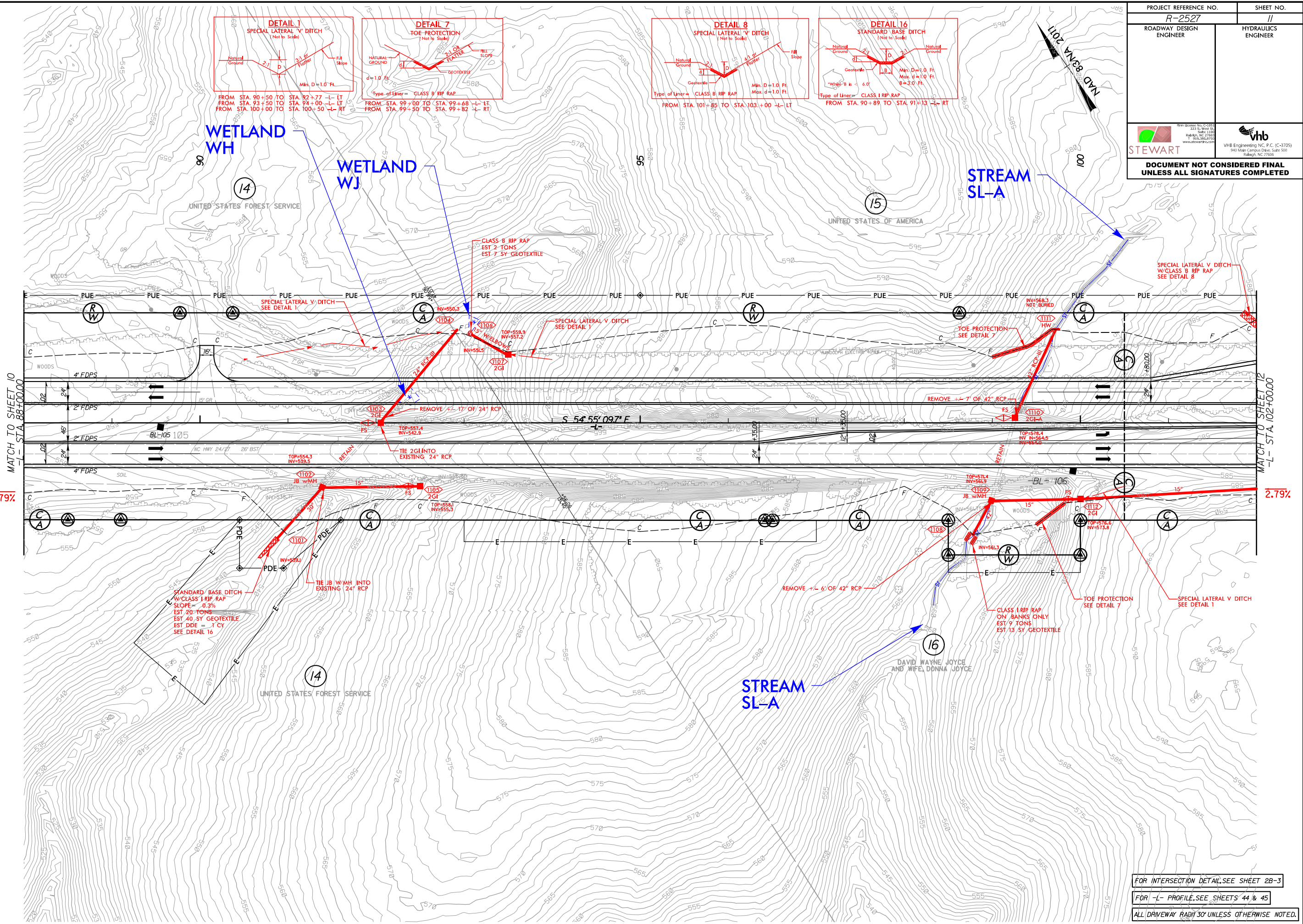

REVISIONS

ROW REV. - April 4, 2019 - PUE revised along Parcels 14 and 15. (MSB)
 ROW REV. - May 27, 2019 - PUE and TCE label revised at -L- +600.00, 102.27 FT. (MSB)

8:37:24 AM
 H:\projects\cadd\PSH\R2527_Hyd_PSH11.dgn
 PSH11



MATCH TO SHEET 10
 -L- STA. 88+00.00

MATCH TO SHEET 12
 -L- STA. 102+00.00

2.79%

2.79%

FOR INTERSECTION DETAIL SEE SHEET 2B-3
 FOR -L- PROFILE SEE SHEETS 44 & 45
 ALL DRIVEWAY RADI 30' UNLESS OTHERWISE NOTED.

PROJECT REFERENCE NO. R-2527	SHEET NO. 12
ROADWAY DESIGN ENGINEER	HYDRAULICS ENGINEER
 Stewart <small>10000 Old Forest Drive, Suite 100 Raleigh, NC 27615 www.stewartinc.com</small>	 Vhb <small>VHB Engineering NC, P.C. (C-3705) 940 Main Campus Drive, Suite 300 Raleigh, NC 27606</small>
DOCUMENT NOT CONSIDERED FINAL UNLESS ALL SIGNATURES COMPLETED	

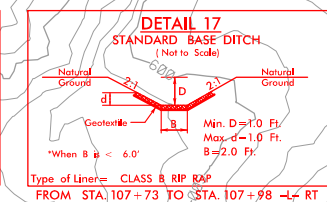
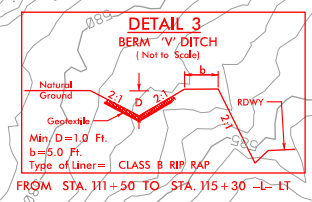
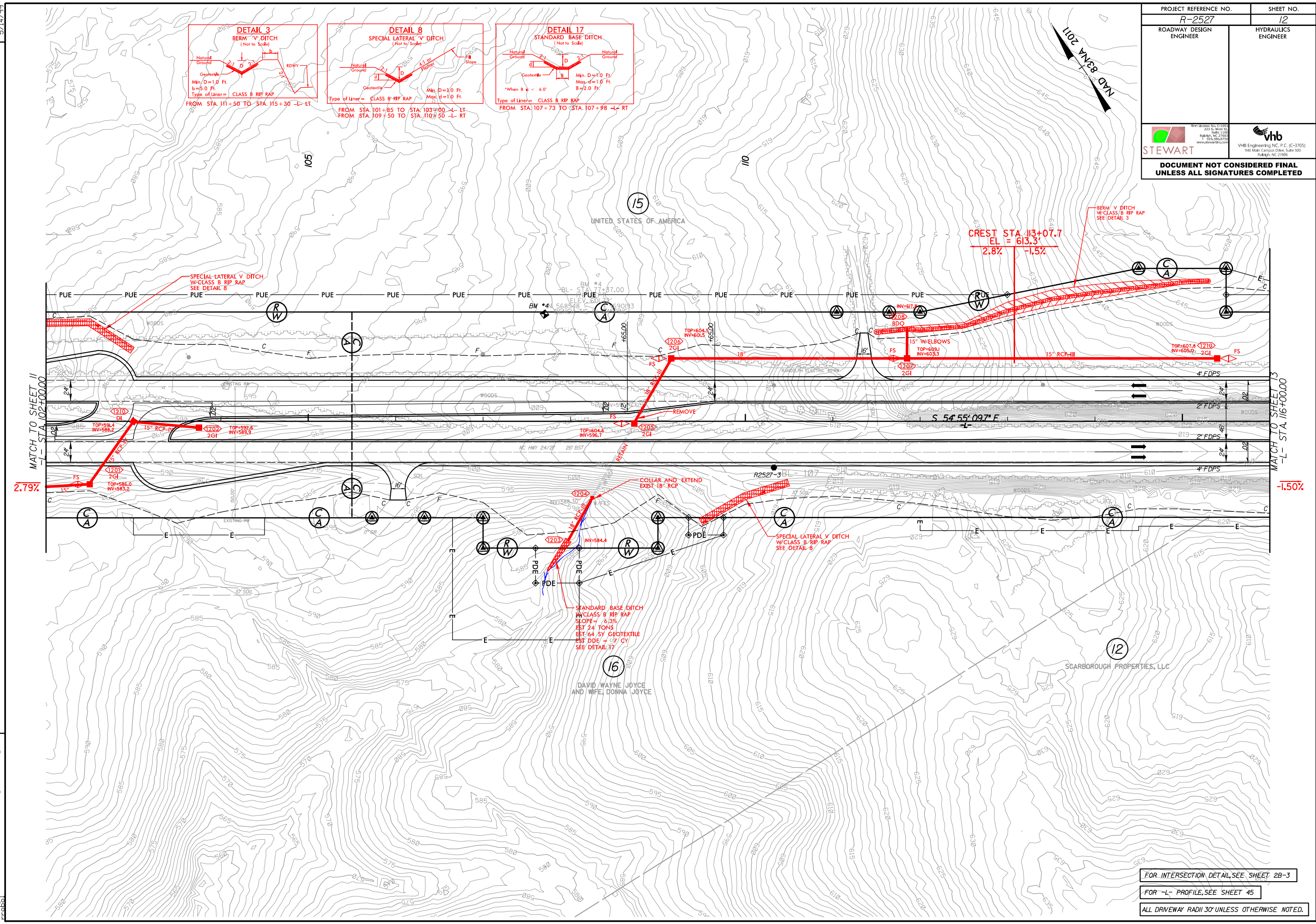

REVISIONS
 ROW REV. - April 4, 2019 - PUE revised along Parcel 15.(MSB)
 TCE added along Parcel 15.(MSB)

8:37:43 AM
 R:\Projects\2527\CADD\PSH\R2527_Hyd_PSH12.dgn

FOR INTERSECTION DETAIL, SEE SHEET 2B-3
 FOR -L- PROFILE, SEE SHEET 45
 ALL DRIVEWAY RADI 30' UNLESS OTHERWISE NOTED.

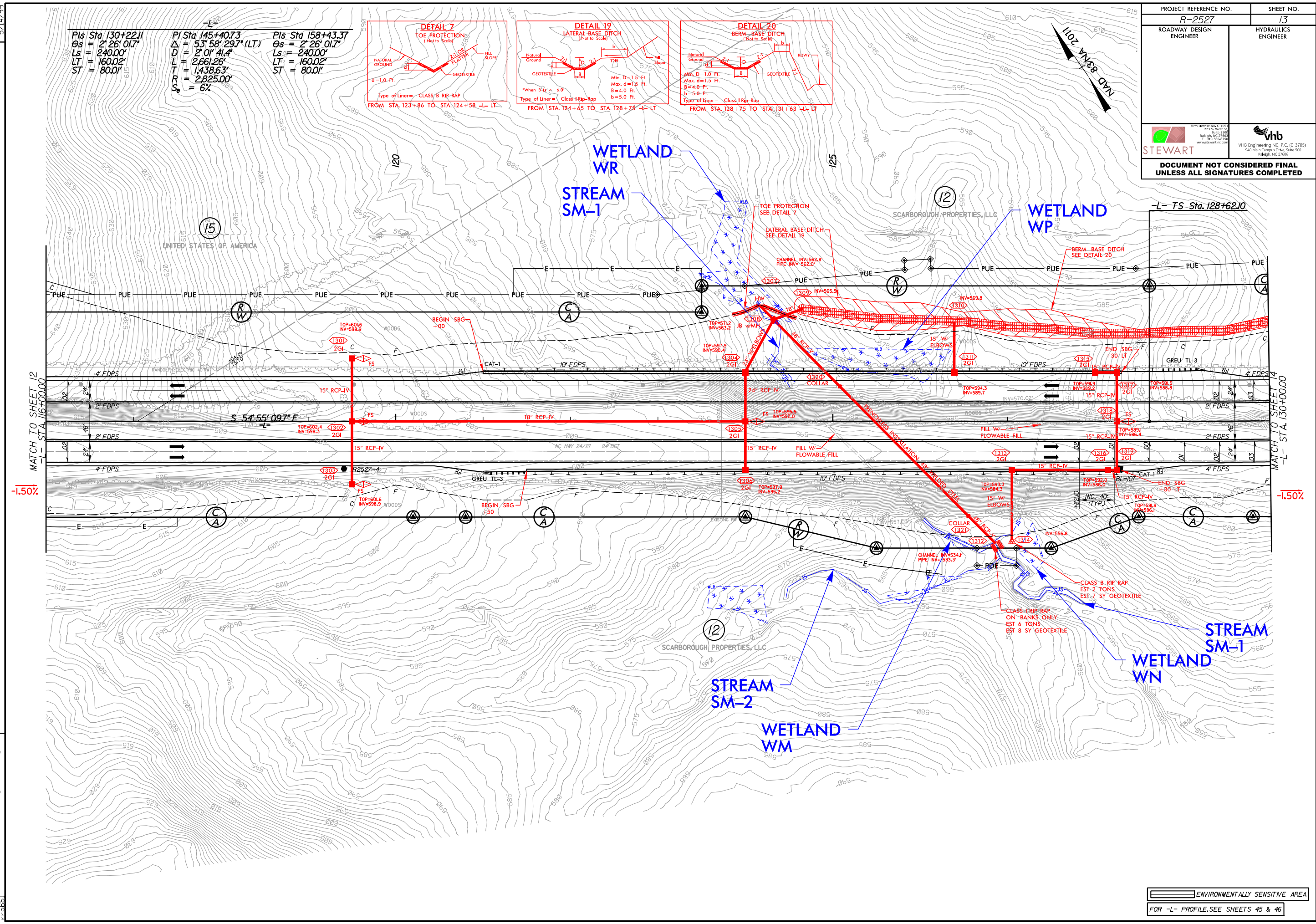

Pls Sta 130+22.11
 $\Theta_s = 2' 26" 01.7"$
 $L_s = 240.00'$
 $LT = 160.02'$
 $ST = 80.01'$

Pls Sta 145+40.73
 $\Delta = 53' 58" 29.7" (LT)$
 $D = 2' 01" 41.4"$
 $L = 2,661.26'$
 $T = 1,438.63'$
 $R = 2,825.00'$
 $S_0 = 6\%$

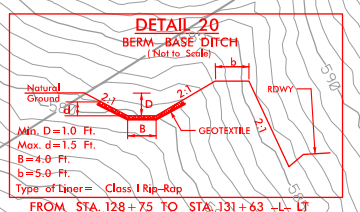
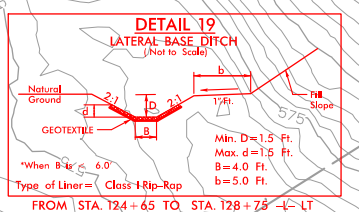
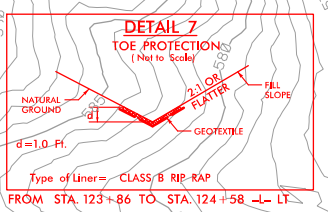

Pls Sta 158+43.37
 $\Theta_s = 2' 26" 01.7"$
 $L_s = 240.00'$
 $LT = 160.02'$
 $ST = 80.01'$



REVISIONS
 ROW REV. - April 4, 2019 - PUE revised along Parcel 12 and 15. TCE added along Parcel 15.(MSB)

8:37:49 AM
 R:\H:\stewart\cadd\PSH\R2527_Hyd_PSH13.dgn
 P:\stewart\cadd\PSH\R2527_Hyd_PSH13.dgn

ENVIRONMENTALLY SENSITIVE AREA
 FOR -L- PROFILE SEE SHEETS 45 & 46

PROJECT REFERENCE NO. R-2527	SHEET NO. 14
ROADWAY DESIGN ENGINEER	HYDRAULICS ENGINEER
 <small>Stewart & Associates, Inc. 223 S. West St. Raleigh, NC 27601 www.stewartinc.com</small>	 <small>Vhb Engineering NC, P.C. (C-3705) 940 Main Campus Drive, Suite 300 Raleigh, NC 27606</small>
DOCUMENT NOT CONSIDERED FINAL UNLESS ALL SIGNATURES COMPLETED	

5/14/99
 ROW REV. - April 4, 2019 - PDE added along Parcel 17, (MSB)
 DUE revised along Parcels 12 and 17, PUE revised along Parcel 17, (MSB)
 TCE revised along Parcel 17, (MSB)
 8:37:55 AM
 R:\1151\1151.dwg
 C:\Users\jacob\OneDrive\Documents\PSH\2527_Hyd_PSH14.dgn

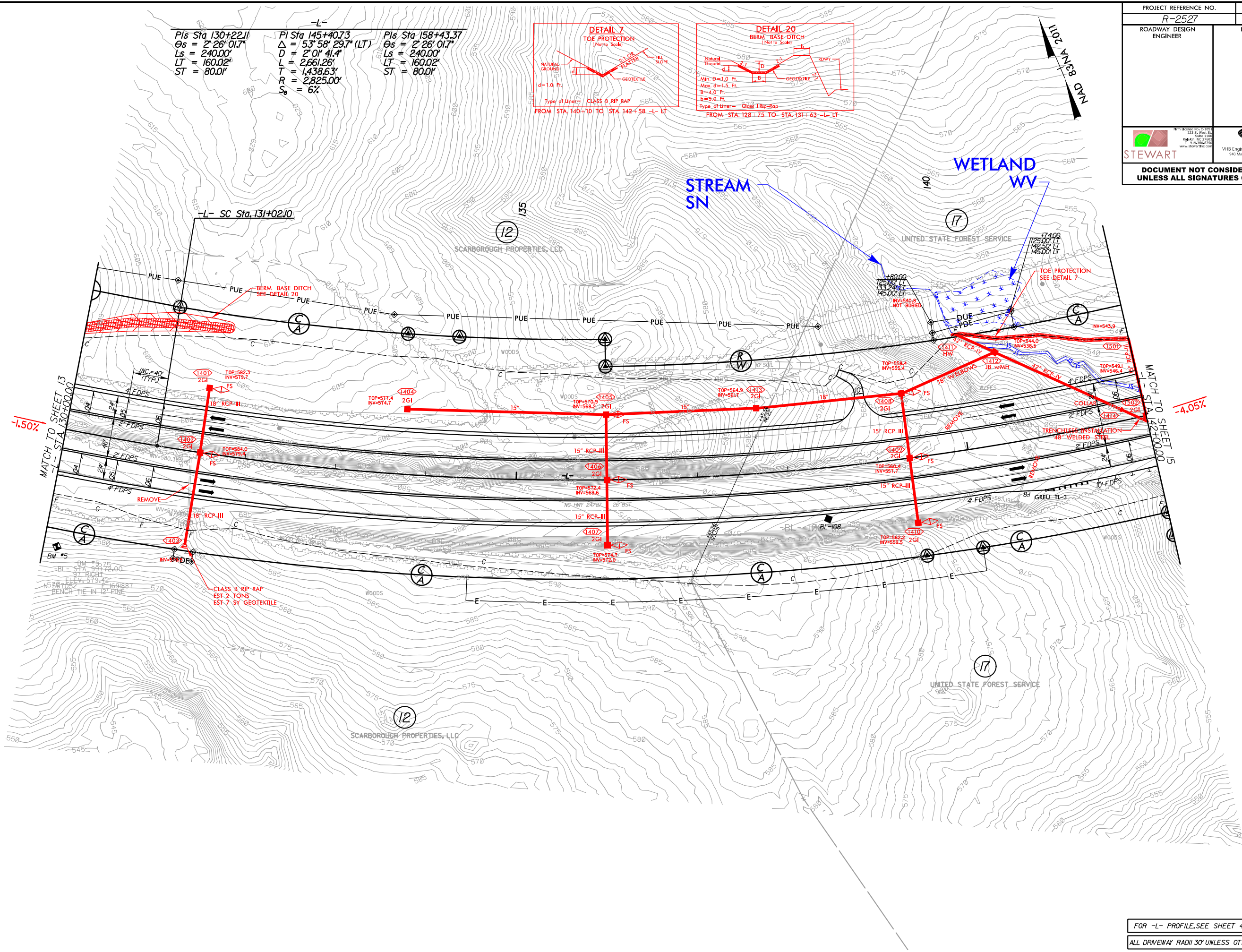

-L-
 Pls Sta 130+22.11
 $\theta_s = 2' 26'' 01.7''$
 $L_s = 240.00'$
 $LT = 160.02'$
 $ST = 80.01'$

-L-
 Pl Sta 145+40.73
 $\Delta = 53' 58'' 29.7'' (LT)$
 $D = 2' 01'' 41.4''$
 $L = 2,661.26'$
 $T = 1,438.63'$
 $R = 2,825.00'$
 $S_e = 6\%$

-L-
 Pls Sta 158+43.37
 $\theta_s = 2' 26'' 01.7''$
 $L_s = 240.00'$
 $LT = 160.02'$
 $ST = 80.01'$

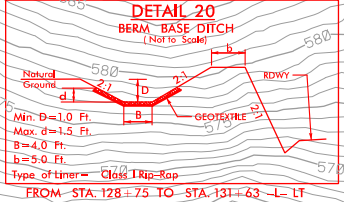
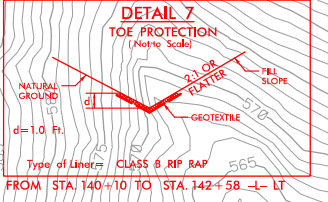

MATCH TO SHEET 13
-L- STA 130+00.00

MATCH TO SHEET 15
-L- STA 142+00.00

-4.05%

FOR -L- PROFILE, SEE SHEET 46
 ALL DRIVEWAY RADII 30' UNLESS OTHERWISE NOTED.

NAD 83 NA 2011

$Pis Sta 130+22.11$
 $\Delta s = 2' 26" 01.7"$
 $Ls = 240.00'$
 $LT = 160.02'$
 $ST = 80.01'$

$PI Sta 145+40.73$
 $\Delta = 53' 58" 29.7" (LT)$
 $D = 2' 01" 41.4"$
 $L = 2,661.26'$
 $T = 1,438.63'$
 $R = 2,825.00'$
 $S_p = 6\%$

$Pis Sta 158+43.37$
 $\Delta s = 2' 26" 01.7"$
 $Ls = 240.00'$
 $LT = 160.02'$
 $ST = 80.01'$

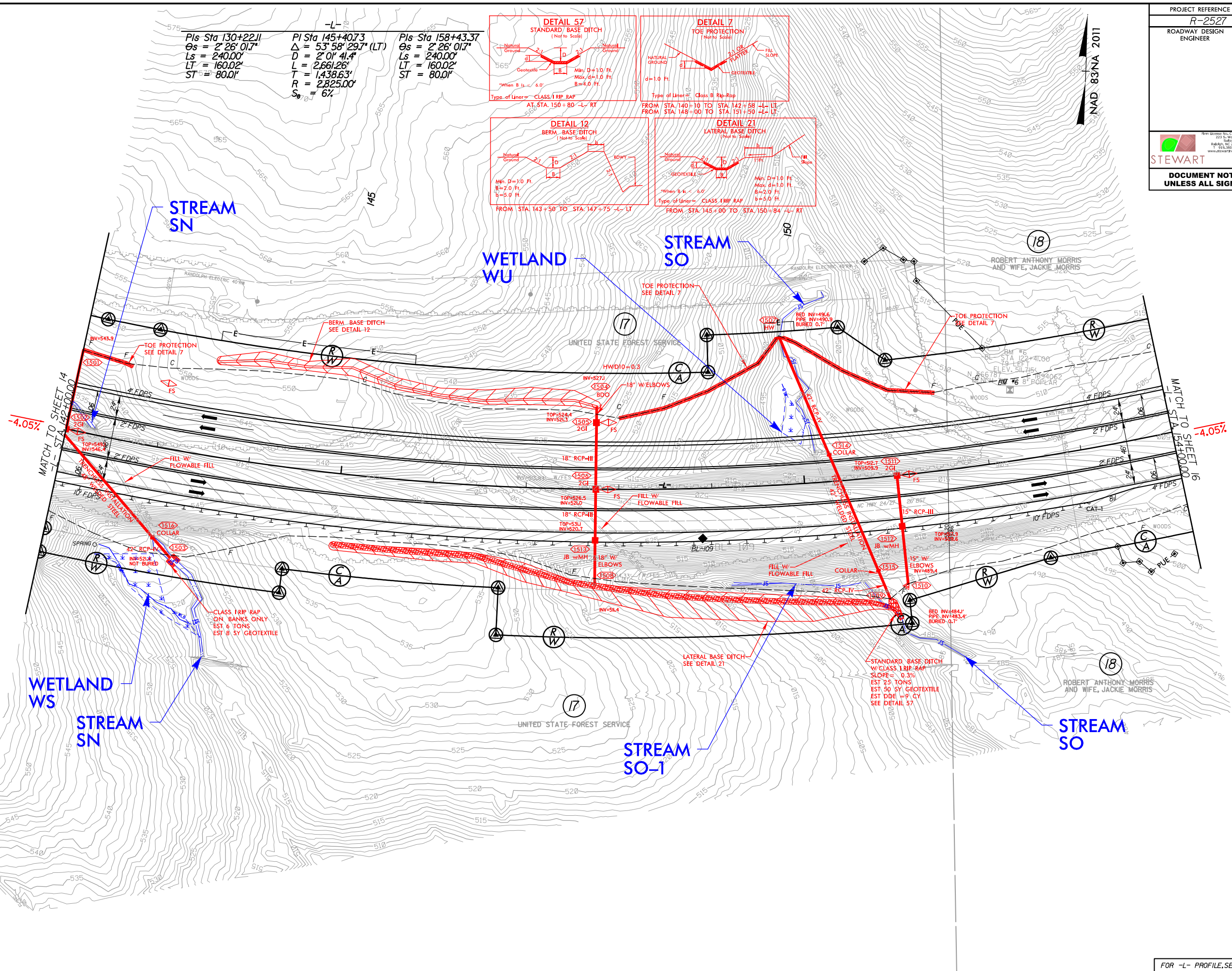
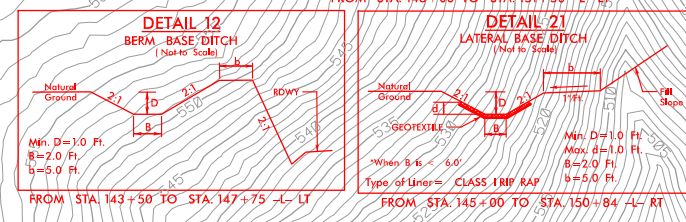
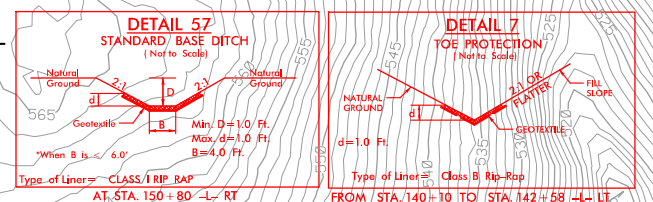

REVISIONS
 ROW REV. - April 4, 2019 - PUE added along Parcels 17 and 18 (MSB)
 ROW REV. - May 27, 2019 - PUE label revised at -L- +10.08, 125.32 LT and -L- +20.25, 109.38 RT. (MSB)
 5/7/14/99
 8:36:02 AM
 R:\Projects\2527\PSH\R2527_Hyd_PSH15.dgn

5/7/14/99
 ROW REV. - April 4, 2019 - DUE revised along Parcel 18, PUE revised along Parcel 18, TCE revised along Parcel 18, (MSB)
 ROW REV. - May 27, 2019 - PUE label revised at -L- +6000, 16017 LT, 20000 LT, (MSB)
 8:36:10 AM
 R:\Hyd\Projects\CADD\PSH\2527_Hyd_PSH16.dgn
 P:\060

-L-
 Pls Sta 130+22.11
 $\Delta s = 2' 26" 01.7"$
 $Ls = 240.00'$
 $LT = 160.02'$
 $ST = 80.01'$

Pls Sta 145+40.73
 $\Delta s = 53' 58" 29.7" (LT)$
 $D = 2' 01" 41.4"$
 $L = 2,661.26'$
 $T = 1,438.63'$
 $R = 2,825.00'$
 $S_0 = 6\%$

Pls Sta 158+43.37
 $\Delta s = 2' 26" 01.7"$
 $Ls = 240.00'$
 $LT = 160.02'$
 $ST = 80.01'$

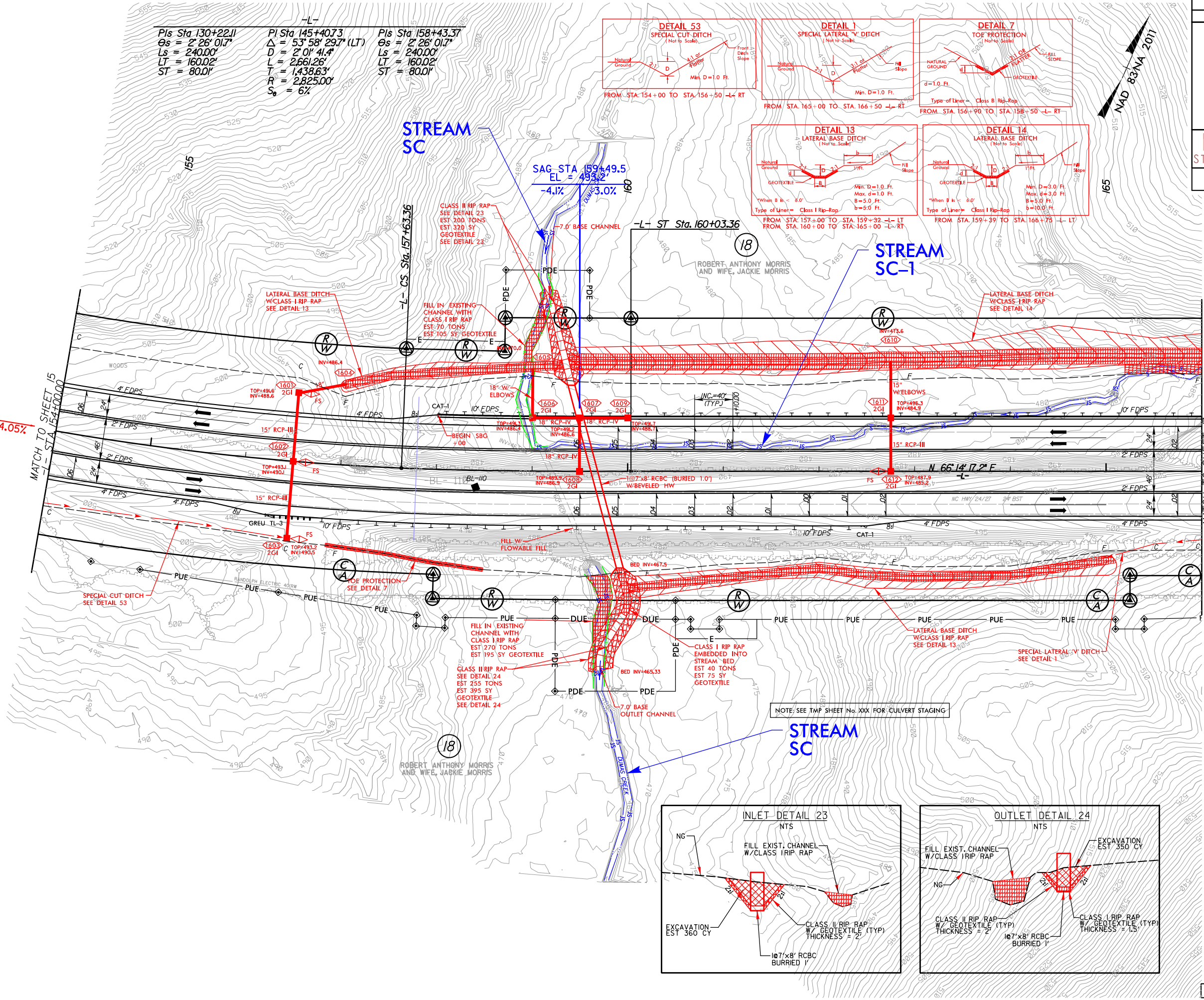

FOR -L- PROFILE, SEE SHEET 47

PROJECT REFERENCE NO. R-2527	SHEET NO. 17
ROADWAY DESIGN ENGINEER	HYDRAULICS ENGINEER
DOCUMENT NOT CONSIDERED FINAL UNLESS ALL SIGNATURES COMPLETED	

NAD 83/NA 2011
**CREST STA 179+01.5
 EL = 538.5'**
 3.0% -2.2%

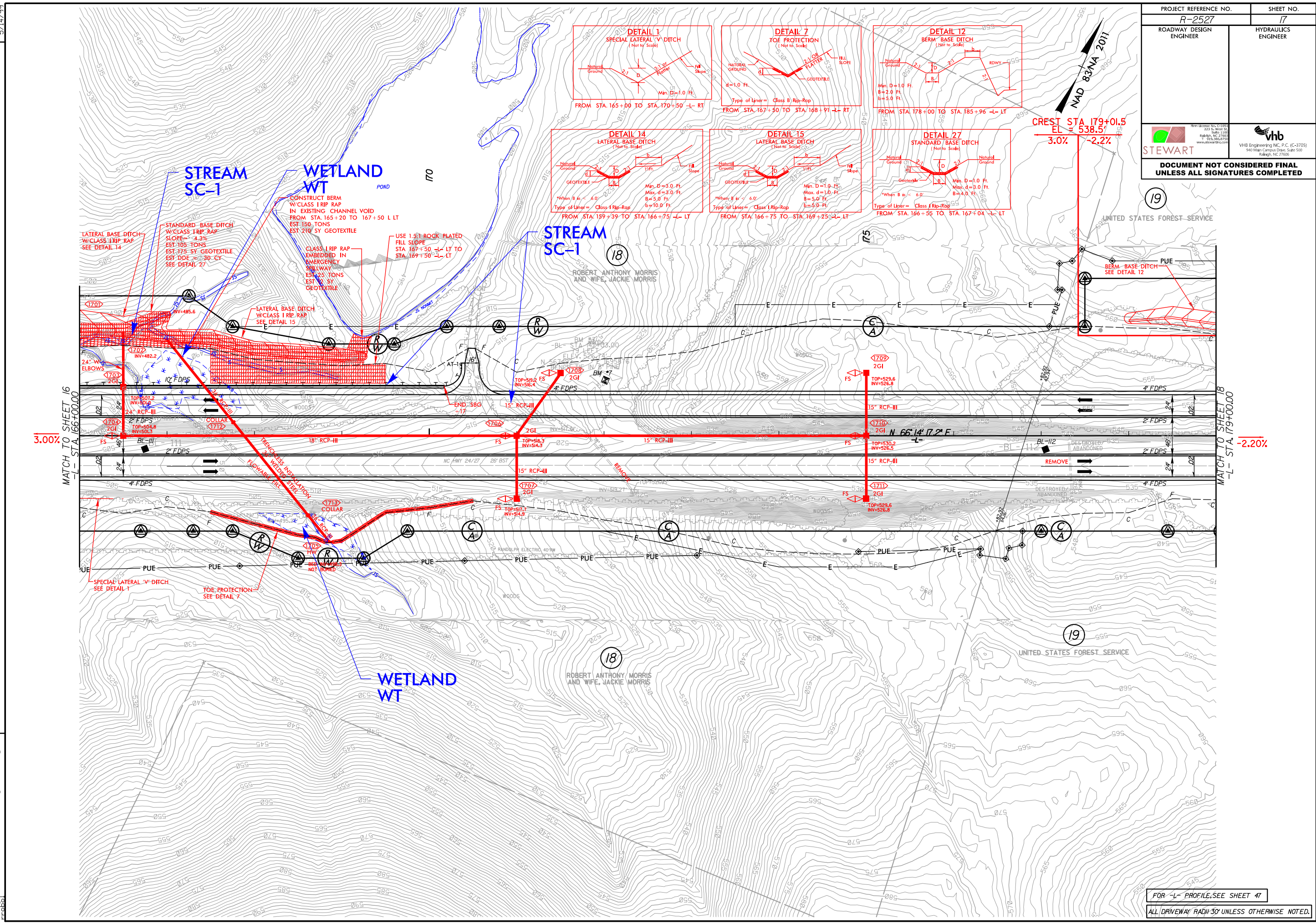

REVISIONS
 ROW REV. - April 4, 2019 - PUE added along Parcel 18 (MSB)
 PUE revised along Parcel 19, TCE revised along Parcel 18 (MSB)
 TCE removed along Parcel 19 (MSB)

8:38:27 AM
 R:\Projects\2527\CADD\PSH\R2527_Hyd_PSH17.dgn

MATCH TO SHEET 16
 -L- STA. 166+00.00

MATCH TO SHEET 18
 -L- STA. 179+00.00

FOR -L- PROFILE, SEE SHEET 17
 ALL DRIVEWAY RADII 30' UNLESS OTHERWISE NOTED.

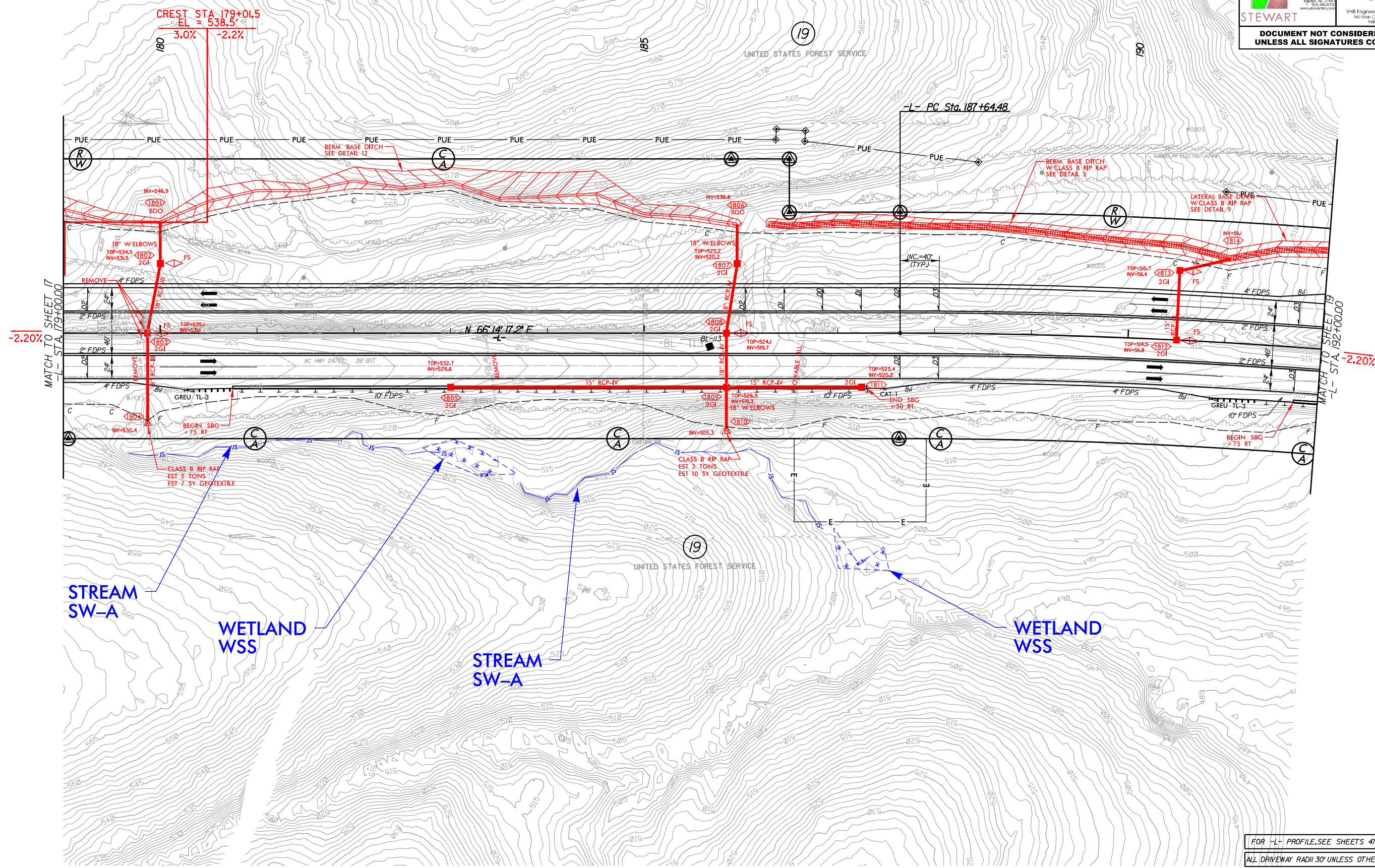
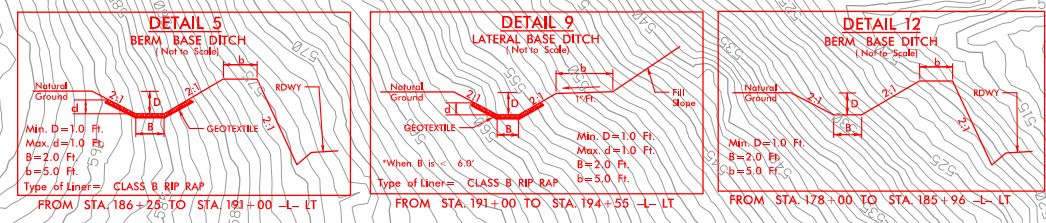

$PI\ Sta\ 192+92.22$
 $\Delta = 10^\circ 29' 16.0" (RT)$
 $D = 0' 59' 47.2"$
 $L = 1,052.52'$
 $T = 527.73'$
 $R = 575.00'$
 $S_0 = 3\%$
 $Runoff = 120'$



REVISIONS

ROW REV. - April 4, 2019 - PUE revised along Parcel 19 (MSB)
 TCE removed along Parcel 19 (MSB)

8:36:29 AM
 R:\Projects\Subsites\CADD\PSH\R2527_Hyd_PSH18.dgn

PROJECT REFERENCE NO. R-2527		SHEET NO. 19	
ROADWAY DESIGN ENGINEER		HYDRAULICS ENGINEER	
			
DOCUMENT NOT CONSIDERED FINAL UNLESS ALL SIGNATURES COMPLETED			

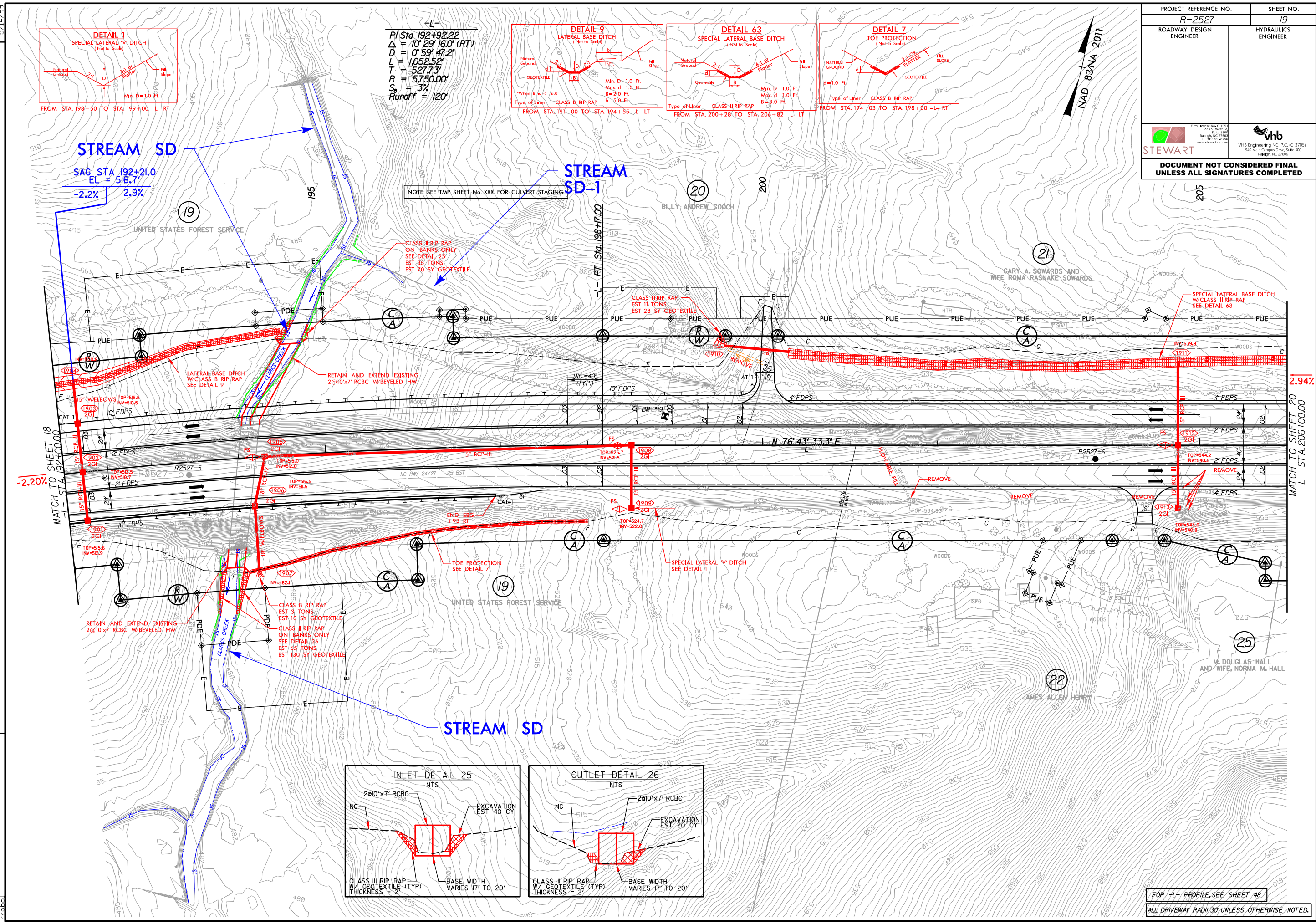

-L-
 P/ Sta 192+92.22
 $\Delta = 10' 29' 16.0''$ (RT)
 $D = 0' 59' 47.2''$
 $L = 1052.52'$
 $T = 527.73'$
 $R = 5750.00'$
 $S_v = 3\%$
 Runoff = 120'

STREAM SD
 SAG STA 192+21.0
 EL = 516.7'
 -2.2% 2.9%



STREAM SD-1

NOTE: SEE TMP SHEET No. XXX FOR CULVERT STAGING

NAD 83 NA 2011

REVISIONS
 ROW REV. - April 4, 2019 - PUE added along Parcel 22, PUE revised along Parcels 19, 20 and 21, TCE removed along Parcel 20, MSB
 ROW REV. - May 20, 2019 - TCE label updated at -L- +05,00, 150.00' LT, 165.00' LT, 220.00' LT, (MSB)
 8:38:39 AM
 R:\Projects\2527\CADD\PSH\R2527_Hyd_PSH19.dgn

FOR -L- PROFILE, SEE SHEET 48
 ALL DRIVEWAY RADI 30' UNLESS OTHERWISE NOTED.

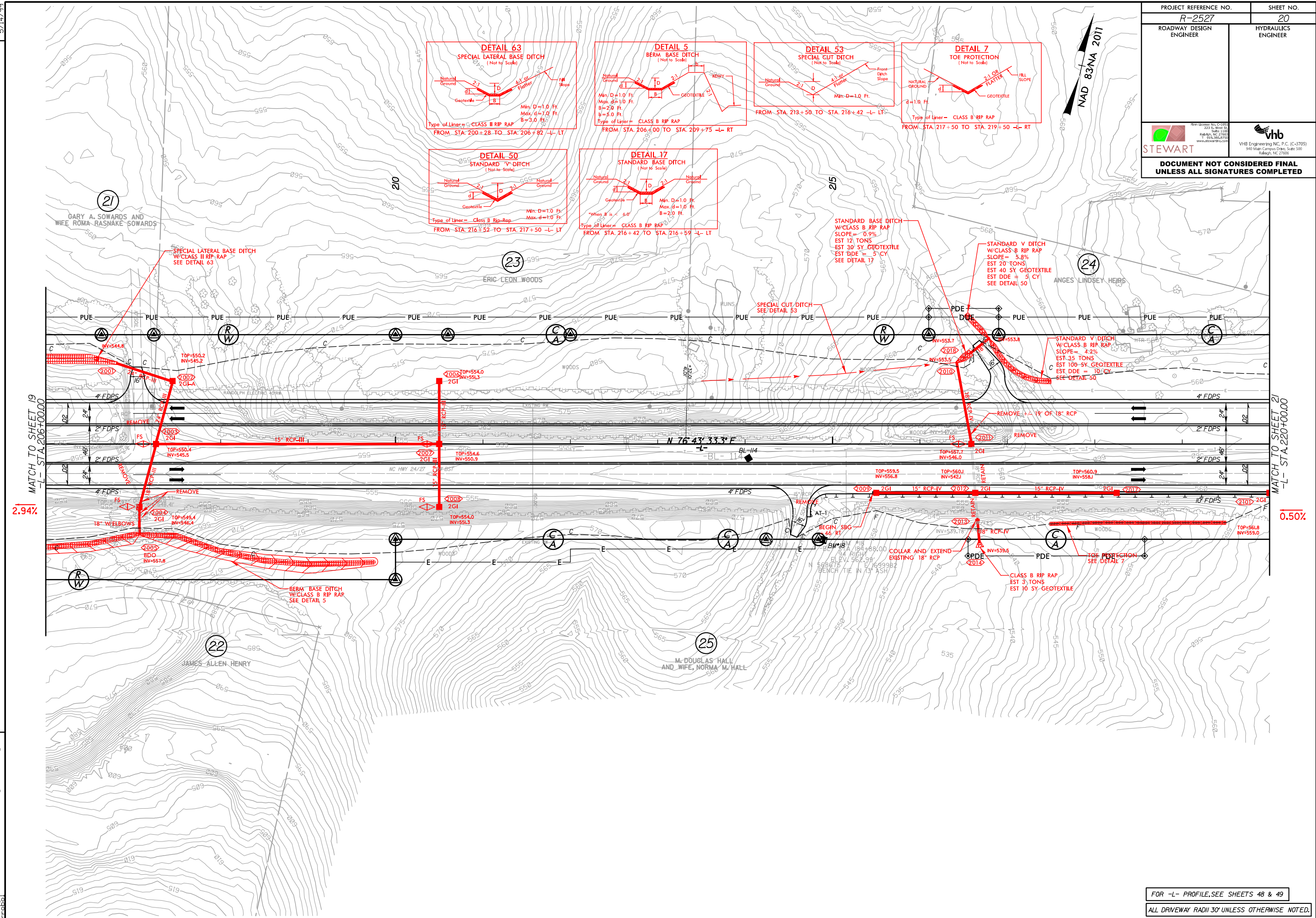

PROJECT REFERENCE NO. R-2527	SHEET NO. 20
ROADWAY DESIGN ENGINEER	HYDRAULICS ENGINEER
 STEWART	 vhb
<small> Form No. ST-101 (Rev. 10/13) 223 S. West St. Raleigh, NC 27601 www.stewartinc.com </small>	
<small> VHB Engineering NC, P.C. (C-3705) 940 Main Campus Drive, Suite 500 Raleigh, NC 27606 </small>	
DOCUMENT NOT CONSIDERED FINAL UNLESS ALL SIGNATURES COMPLETED	



REVISIONS

ROW REV. - April 4, 2019 - DUE revised along Parcel 24, PDE revised along Parcel 22, 23 and 24, (MSB)
 ROW REV. - May 20, 2019 - ROW labels added at -L- +0000.00, 125.00 LI and -L- +600.00, 125.00 LI, (MSB)

8:39:53 AM
 C:\Users\psnar2527\Hyd_PSH20.dgn

PROJECT REFERENCE NO. R-2527	SHEET NO. 21
ROADWAY DESIGN ENGINEER	HYDRAULICS ENGINEER
 <small>Stewart & Associates, Inc. 223 S. West St. Raleigh, NC 27601 www.stewartinc.com</small>	 <small>VHB Engineering NC, P.C. (C-3705) 940 Mar. Campus Drive, Suite 900 Raleigh, NC 27606</small>

**DOCUMENT NOT CONSIDERED FINAL
UNLESS ALL SIGNATURES COMPLETED**

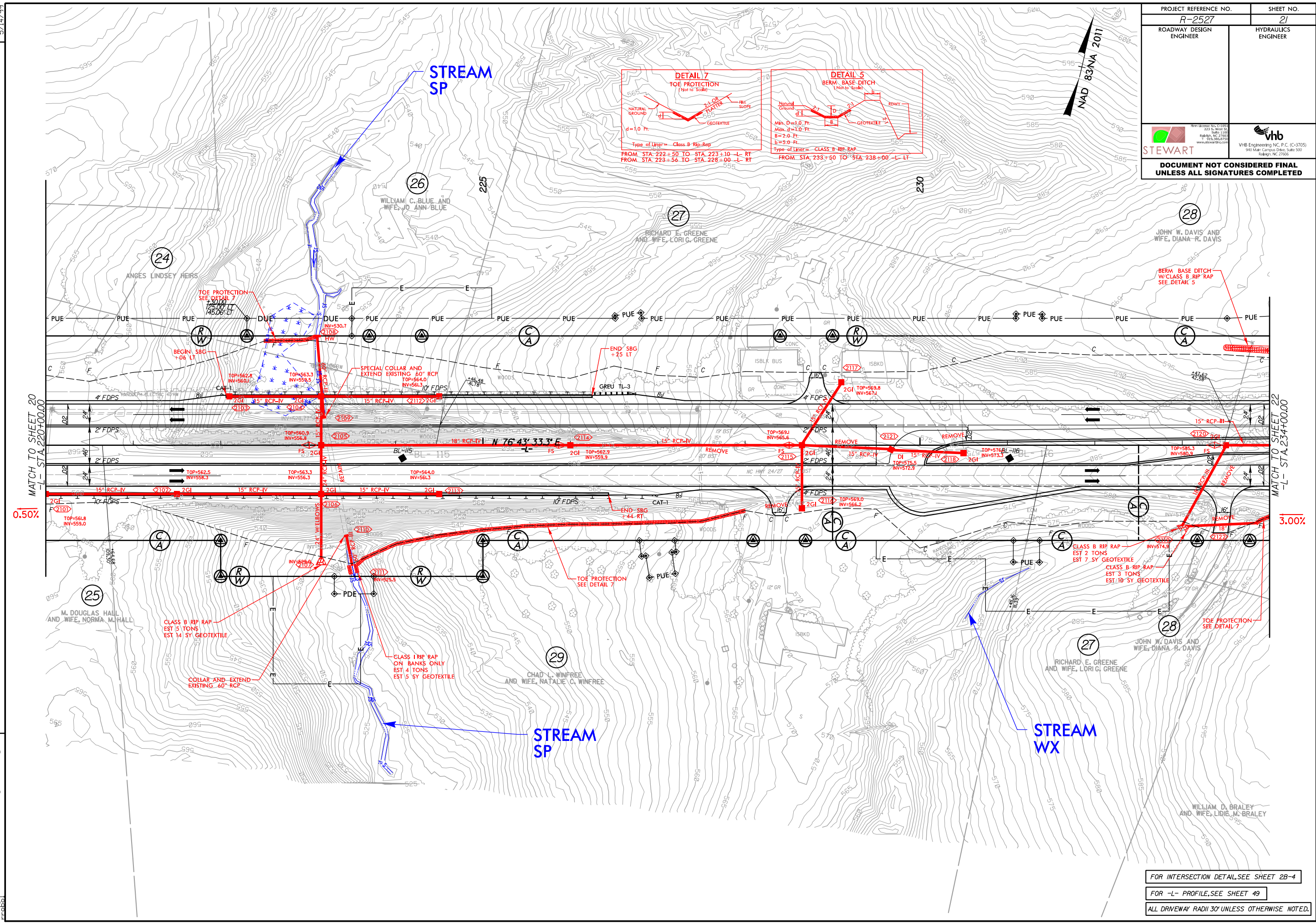

REVISIONS
ROW REV. - April 4, 2019 - PUE added along Parcels 27 and 29.(MSB)
DUE revised along Parcel 26, PUE revised along Parcels 24, 26, 27 and 28. TCE revised along Parcels 26 and 27.(MSB)

8:39:05 AM
R:\Projects\2527\CADD\PSH\R2527_Hyd_PSH21.dgn

FOR INTERSECTION DETAIL, SEE SHEET 2B-4
FOR -L- PROFILE, SEE SHEET 49
ALL DRIVEWAY RADII 30' UNLESS OTHERWISE NOTED.

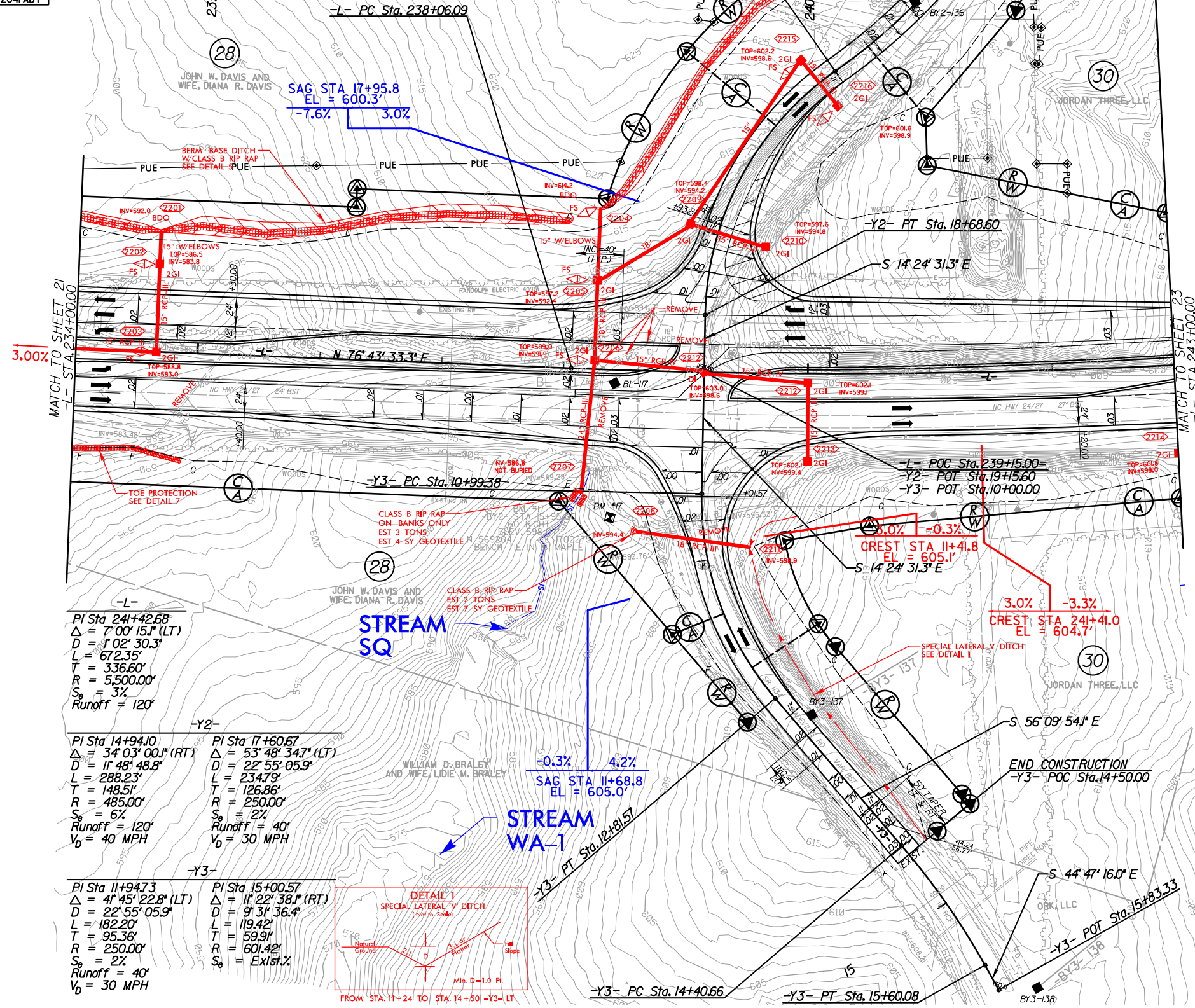
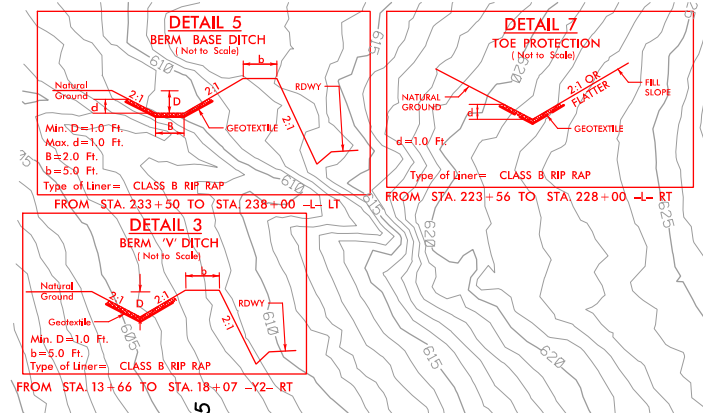
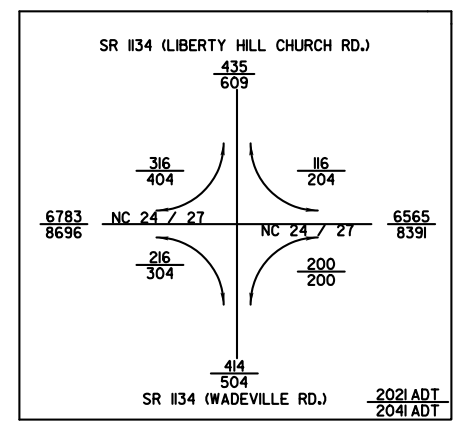

-L-
 PI Sta 241+42.68
 $\Delta = 7^{\circ} 00' 15.1''$ (LT)
 $D = 1^{\circ} 02' 30.3''$
 $L = 672.35'$
 $T = 336.60'$
 $R = 5,500.00'$
 $S_p = 3\%$
 Runoff = 120'

-Y2-
 PI Sta 14+94.10
 $\Delta = 3^{\circ} 4' 03.00''$ (RT)
 $D = 1^{\circ} 48' 48.8''$
 $L = 288.23'$
 $T = 148.51'$
 $R = 485.00'$
 $S_p = 6\%$
 Runoff = 120'
 $V_D = 40$ MPH

PI Sta 17+60.67
 $\Delta = 5^{\circ} 48' 34.7''$ (LT)
 $D = 2^{\circ} 55' 05.9''$
 $L = 234.79'$
 $T = 126.86'$
 $R = 250.00'$
 $S_p = 2\%$
 Runoff = 40'
 $V_D = 30$ MPH

-Y3-
 PI Sta 11+94.73
 $\Delta = 4^{\circ} 45' 22.8''$ (LT)
 $D = 2^{\circ} 55' 05.9''$
 $L = 182.20'$
 $T = 95.36'$
 $R = 250.00'$
 $S_p = 2\%$
 Runoff = 40'
 $V_D = 30$ MPH

PI Sta 15+00.57
 $\Delta = 1^{\circ} 22' 38.1''$ (RT)
 $D = 9^{\circ} 31' 36.4''$
 $L = 119.42'$
 $T = 59.91'$
 $R = 601.42'$
 $S_p = \text{Exist.}\%$

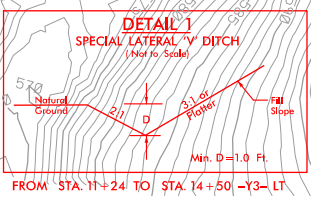



REVISIONS

ROW REV. - April 4, 2019 - PUE revised along Parcels 28 and 30. (MSB)
 ROW REV. - May 20, 2019 - PUE label updated at -L- +51.23, 175.14 LT, -Y2- +65.14, 163.30 LT, -Y2- +51.89, 180.84 LT, -Y2- +63.93, 197.92 LT. (MSB)
 5/14/19

B:\Projects\2527\PSH\PSH22.dgn
 PSH22.dgn

FOR INTERSECTION DETAIL, SEE SHEETS 28-5
 FOR -L- PROFILE, SEE SHEETS 49 & 50
 FOR -Y2- PROFILE, SEE SHEET 59
 FOR -Y3- PROFILE, SEE SHEET 59

PROJECT REFERENCE NO. R-2527	SHEET NO. 23
ROADWAY DESIGN ENGINEER	HYDRAULICS ENGINEER
 STEWART	 VHB
DOCUMENT NOT CONSIDERED FINAL UNLESS ALL SIGNATURES COMPLETED	

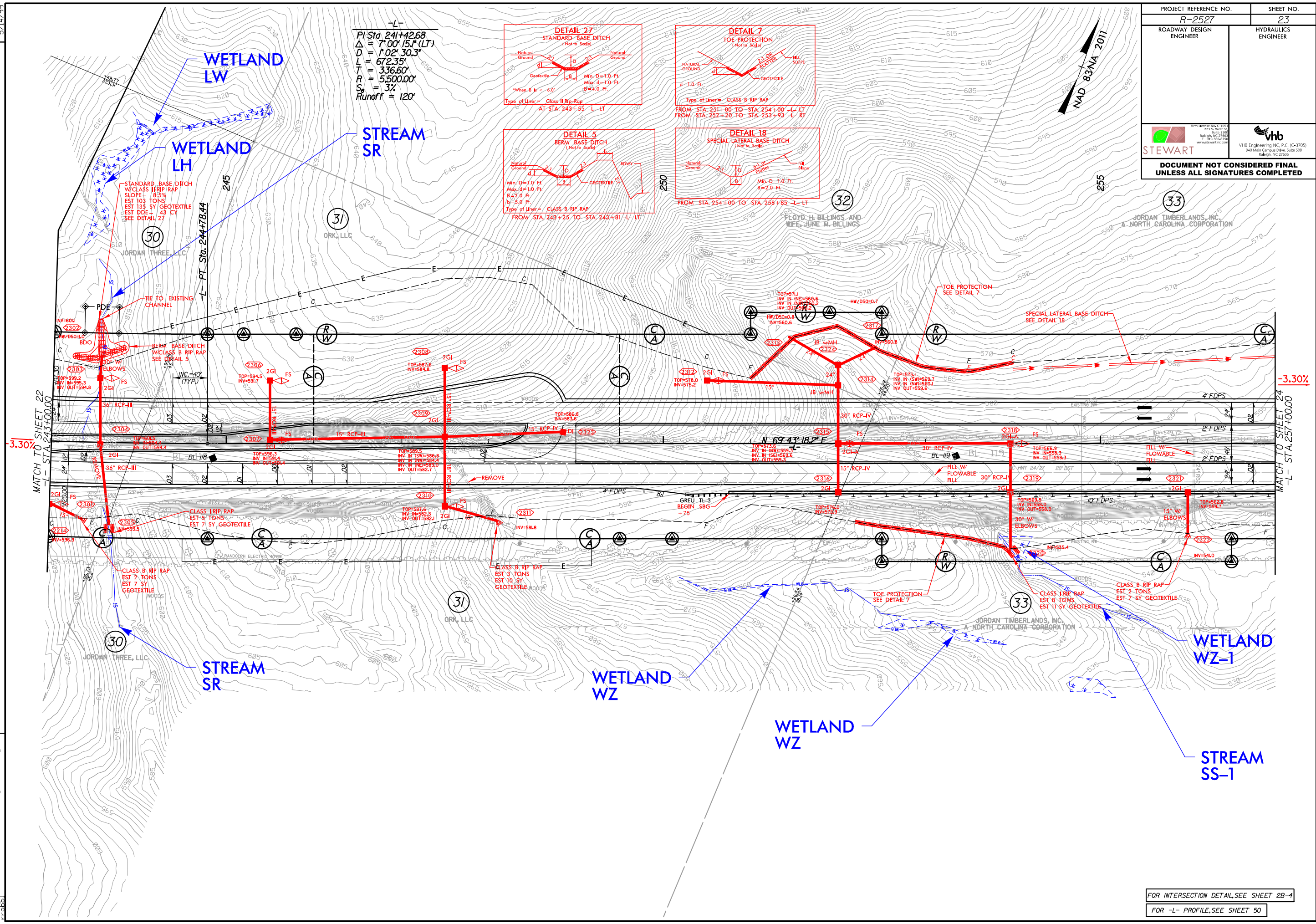

-L-
 $PI\ Sta. 241+42.68$
 $\Delta = 7^{\circ}00'15.1''(LT)$
 $D = 672.35'$
 $T = 336.60'$
 $R = 5,500.00'$
 $S = 3\%$
 $Runoff = 120'$

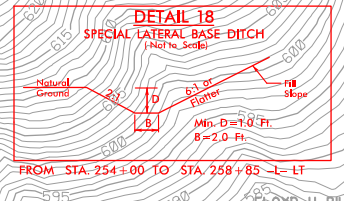
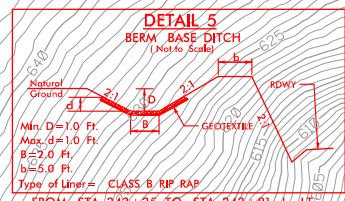
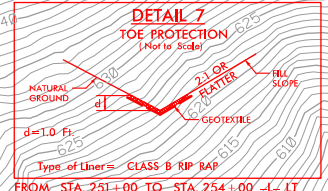
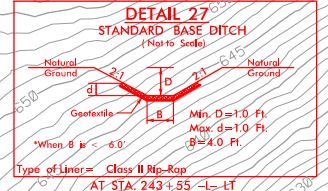

MATCH TO SHEET 22
-L- STA. 243+00.00

MATCH TO SHEET 24
-L- STA. 257+00.00

REVISIONS

ROW REV. - April 4, 2019 - PUE removed along Parcel 33.(MSB)

8:39:20 AM
 R:\Projects\2019\2527\CADD\PSH\R2527_Hyd_PSH23.dgn
 P:\010

FOR INTERSECTION DETAIL, SEE SHEET 2B-4
 FOR -L- PROFILE, SEE SHEET 50

**DOCUMENT NOT CONSIDERED FINAL
UNLESS ALL SIGNATURES COMPLETED**

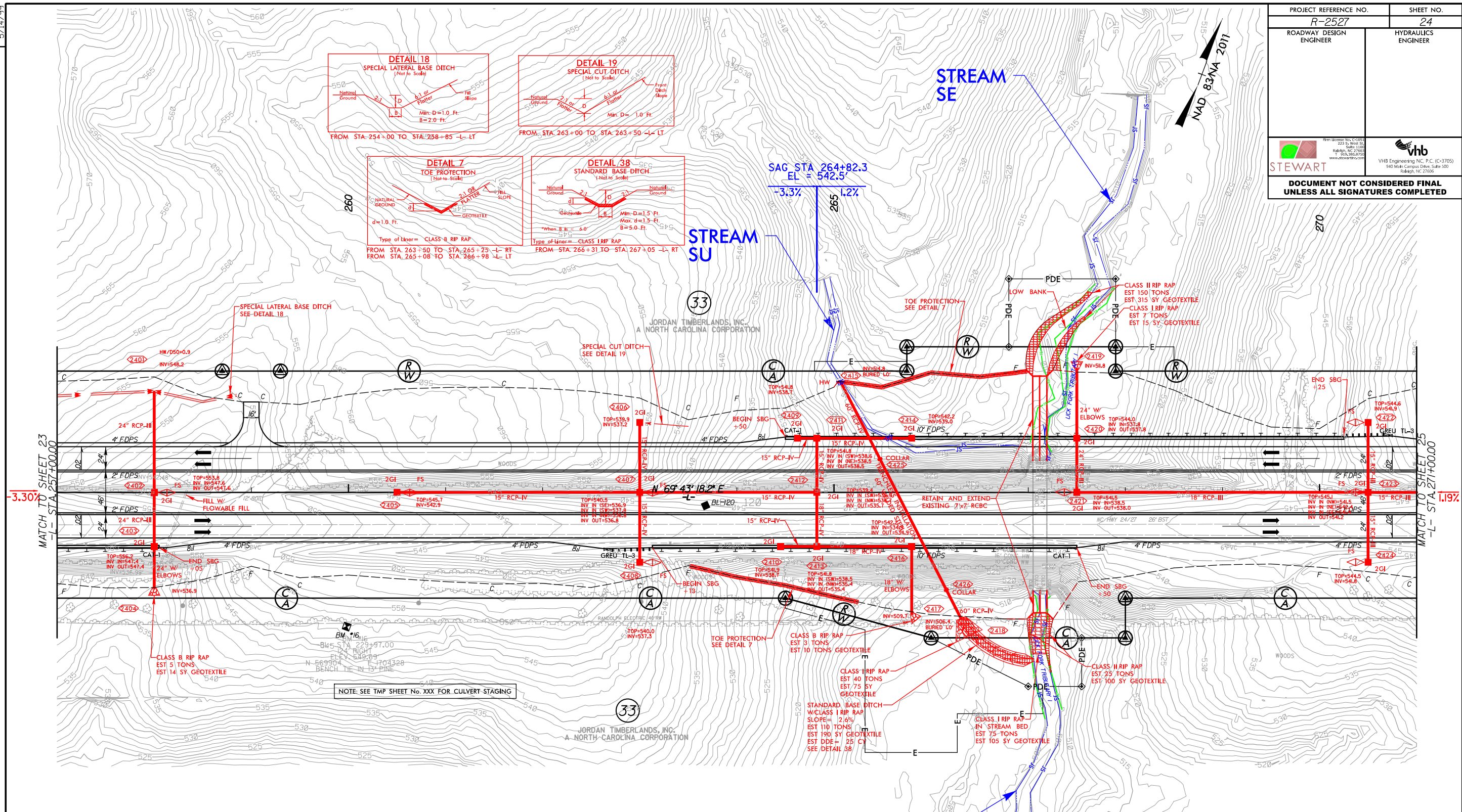



REVISIONS

MATCH TO SHEET 23
-L- STA 257+00.00

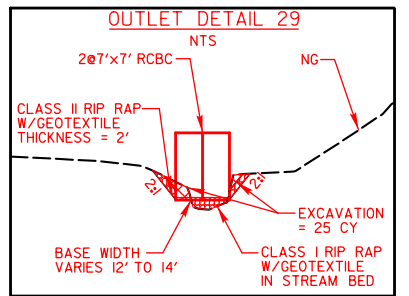
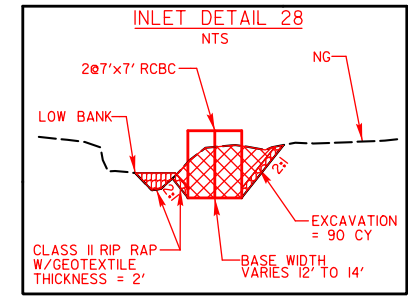
MATCH TO SHEET 25
-L- STA 271+00.00



8:39:26 AM
 R:\Projects\2527\CADD\PSH\R2527_Hyd_PSH24.dgn
 P:\Projects\2527\CADD\PSH\R2527_Hyd_PSH24.dgn

PROJECT REFERENCE NO. R-2527	SHEET NO. 25
ROADWAY DESIGN ENGINEER	HYDRAULICS ENGINEER
 <small>Stewart Engineering & Construction, Inc. 223 S. West St. Raleigh, NC 27601 www.stewartinc.com</small>	 <small>VHB Engineering NC, P.C. (C-3705) 140 Main Campus Drive, Suite 500 Raleigh, NC 27606</small>
DOCUMENT NOT CONSIDERED FINAL UNLESS ALL SIGNATURES COMPLETED	

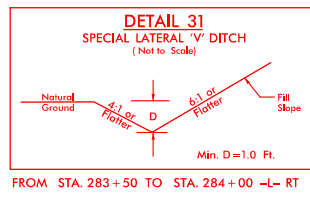
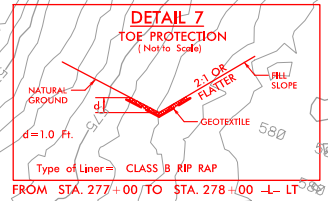
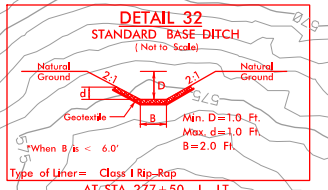
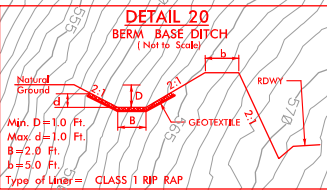
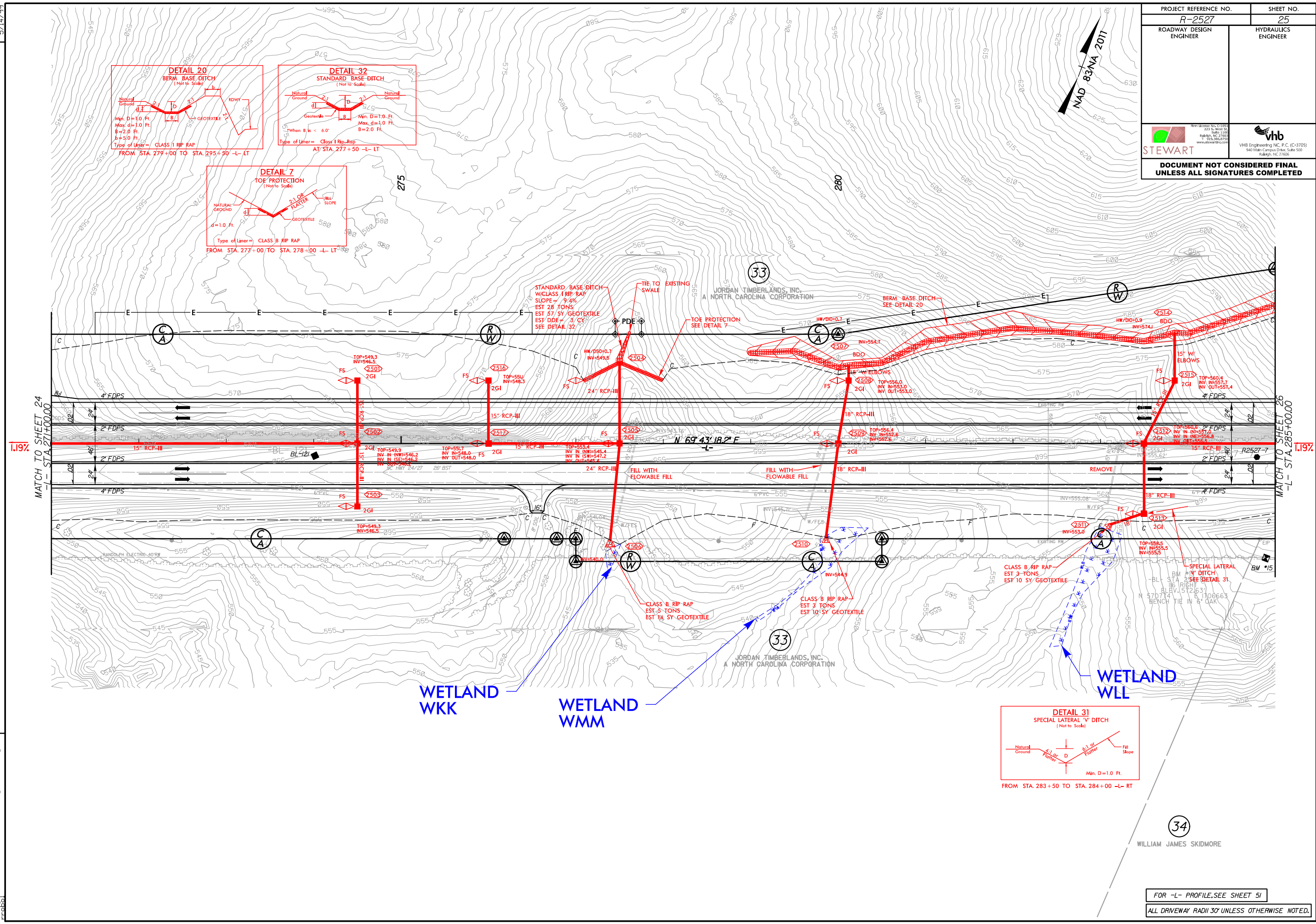



REVISIONS

ROW REV. - April 4, 2019 - PUE removed along Parcel 33.(MSB)

8:39:32 AM
R:\Projects\Subsites\CADD\PSH\R2527_Hyd_PSH25.dgn

34
WILLIAM JAMES SKIDMORE

FOR -L- PROFILE, SEE SHEET 51
ALL DRIVEWAY RADII 30' UNLESS OTHERWISE NOTED.

PROJECT REFERENCE NO. R-2527	SHEET NO. 26
ROADWAY DESIGN ENGINEER	HYDRAULICS ENGINEER
 STEWART <small>1000 S. West St. Raleigh, NC 27601 www.stewarteng.com</small>	 VHB <small>VHB Engineering, P.C. (C-3705) 940 Main Campus Drive, Suite 300 Raleigh, NC 27606</small>

**DOCUMENT NOT CONSIDERED FINAL
UNLESS ALL SIGNATURES COMPLETED**

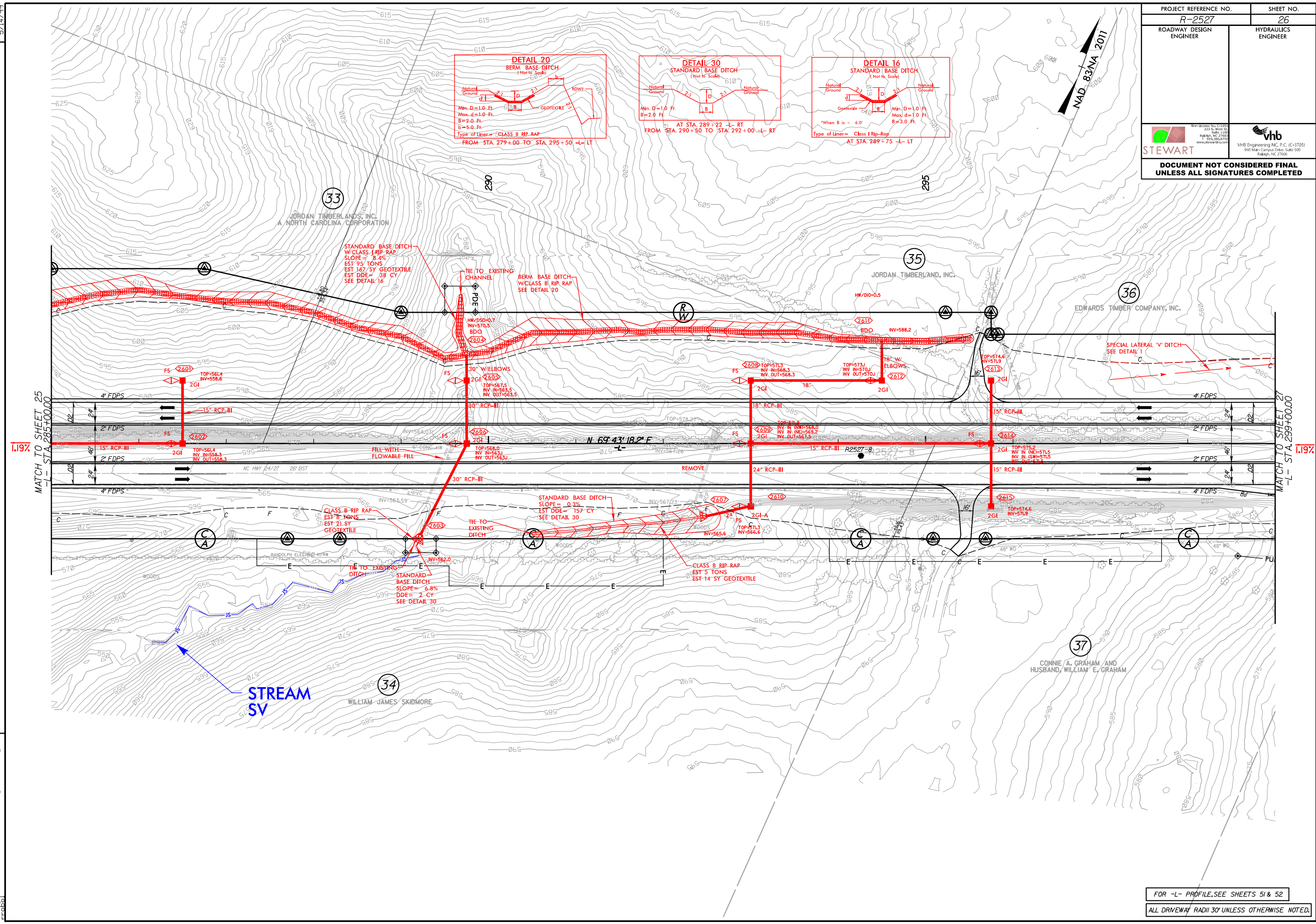

REVISIONS
 ROW REV. - April 4, 2019 - PUE added along Parcel 37. (MSB)

5/14/99
 8:39:45 AM
 R:\Projects\2527\CADD\PSH\R2527_Hyd_PSH26.dgn

MATCH TO SHEET 25
 -L- STA. 285+00.00

MATCH TO SHEET 27
 -L- STA. 299+00.00

FOR -L- PROFILE, SEE SHEETS 51 & 52
 ALL DRIVEWAY RADI 30' UNLESS OTHERWISE NOTED.

PROJECT REFERENCE NO. R-2527	SHEET NO. 27
ROADWAY DESIGN ENGINEER	HYDRAULICS ENGINEER
STEWART	vhb
DOCUMENT NOT CONSIDERED FINAL UNLESS ALL SIGNATURES COMPLETED	

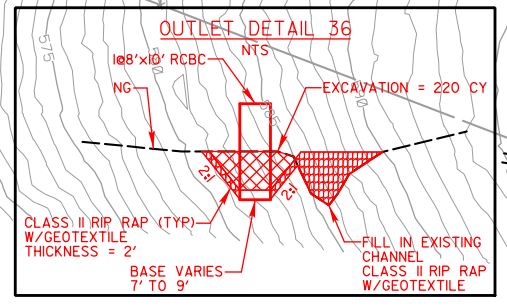
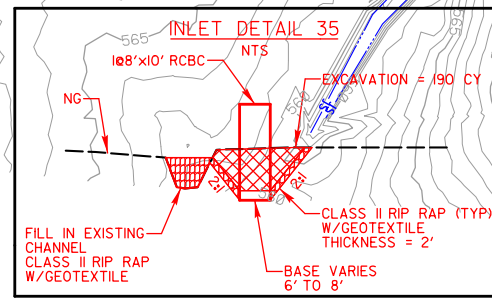
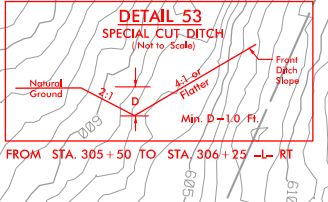
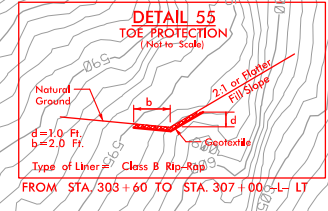
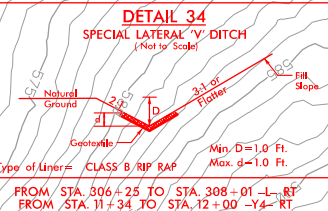
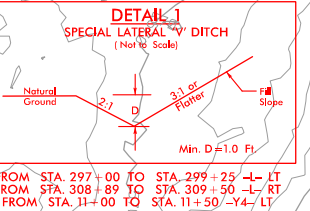
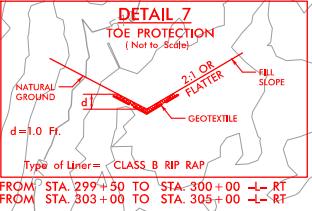
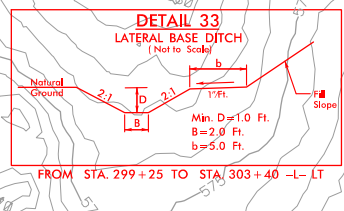
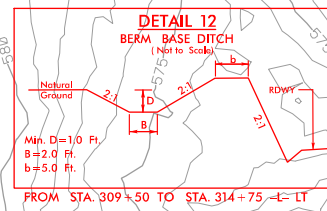
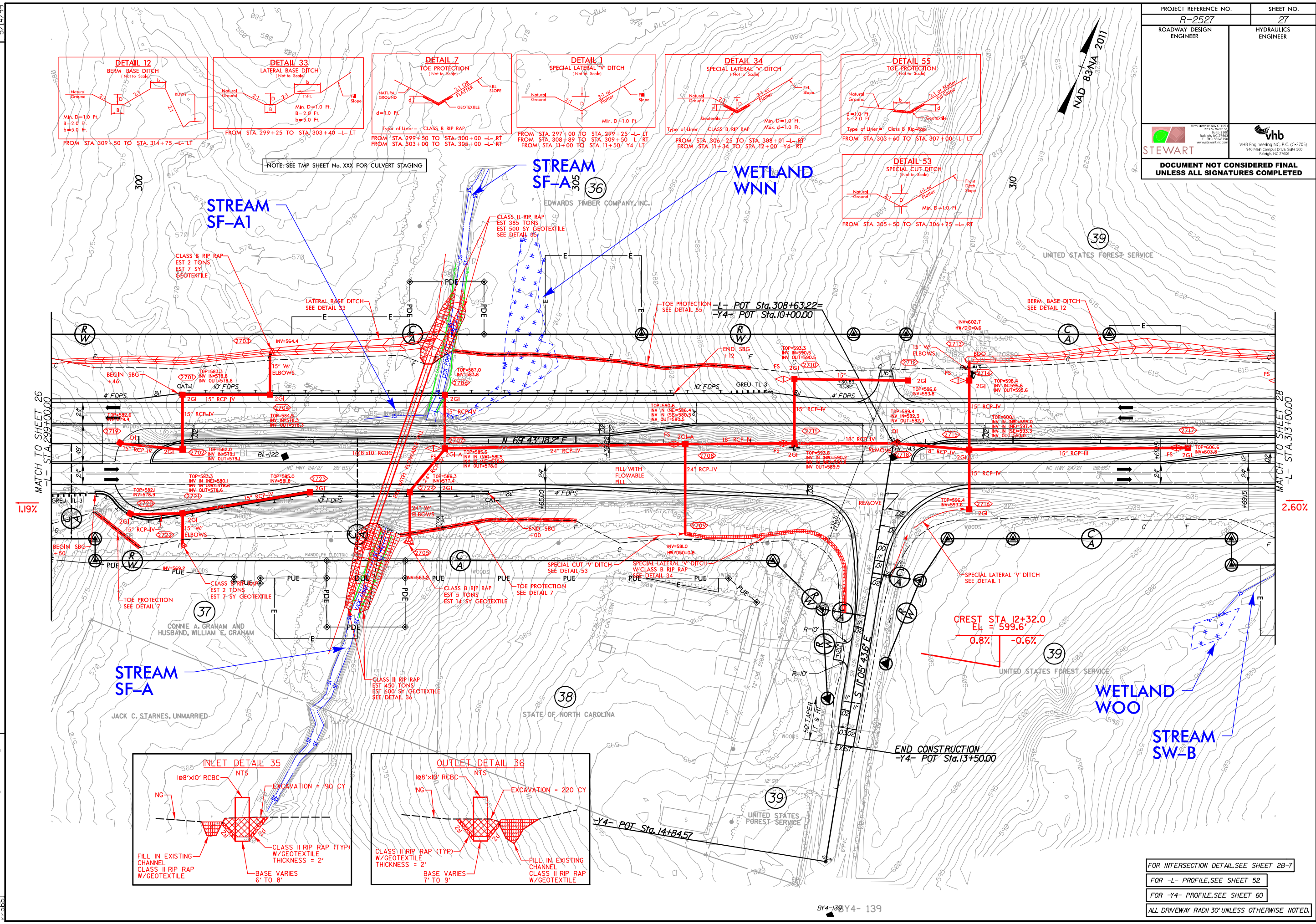

REVISIONS
ROW REV. - April 4, 2019 - DUE revised along Parcel 37. PUE revised along Parcel 37 and 38. TCE revised along Parcels 37 and 38. (MSB)

8:39:59 AM
R:\Projects\2527\CADD\PSH\R2527_Hyd_PSH27.dgn

FOR INTERSECTION DETAIL, SEE SHEET 28-7
FOR -L- PROFILE, SEE SHEET 52
FOR -Y4- PROFILE, SEE SHEET 60
ALL DRIVEWAY RADI 30' UNLESS OTHERWISE NOTED.

PROJECT REFERENCE NO.		SHEET NO.	
R-2527		28	
ROADWAY DESIGN ENGINEER		HYDRAULICS ENGINEER	
STEWART		vhb	
<small>1000 Lakeshore Dr. Cary, NC 27513 919.487.2100 www.stewartinc.com</small>		<small>VHB Engineering NC, P.C. (C-3705) 940 Khan Campus Drive, Suite 500 Raleigh, NC 27606</small>	
DOCUMENT NOT CONSIDERED FINAL UNLESS ALL SIGNATURES COMPLETED			

5/14/99

REVISIONS

R:\1004 AM
1004\1004.ctb\cadd\PSHR2527_Hyd_PSH28.dgn

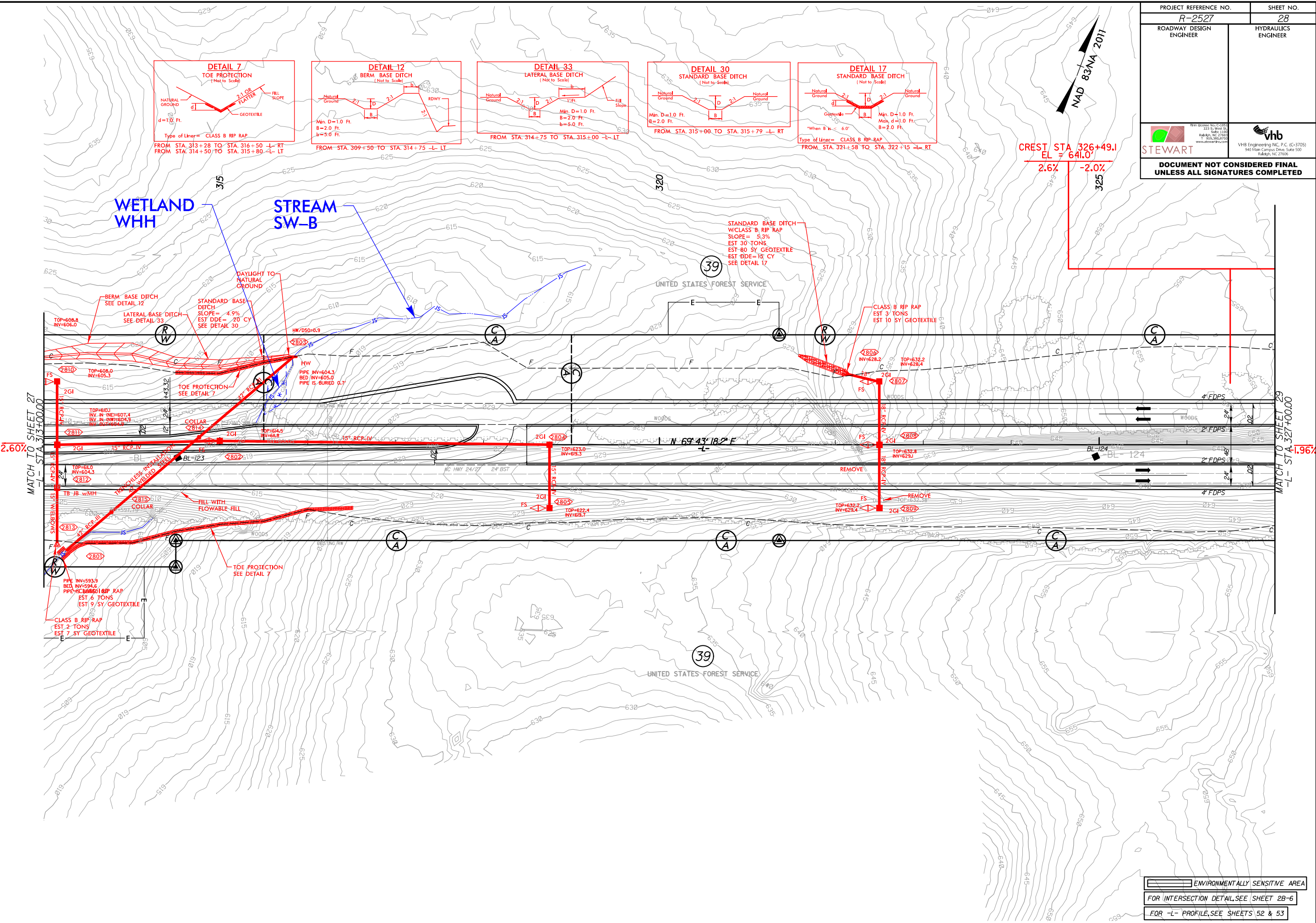

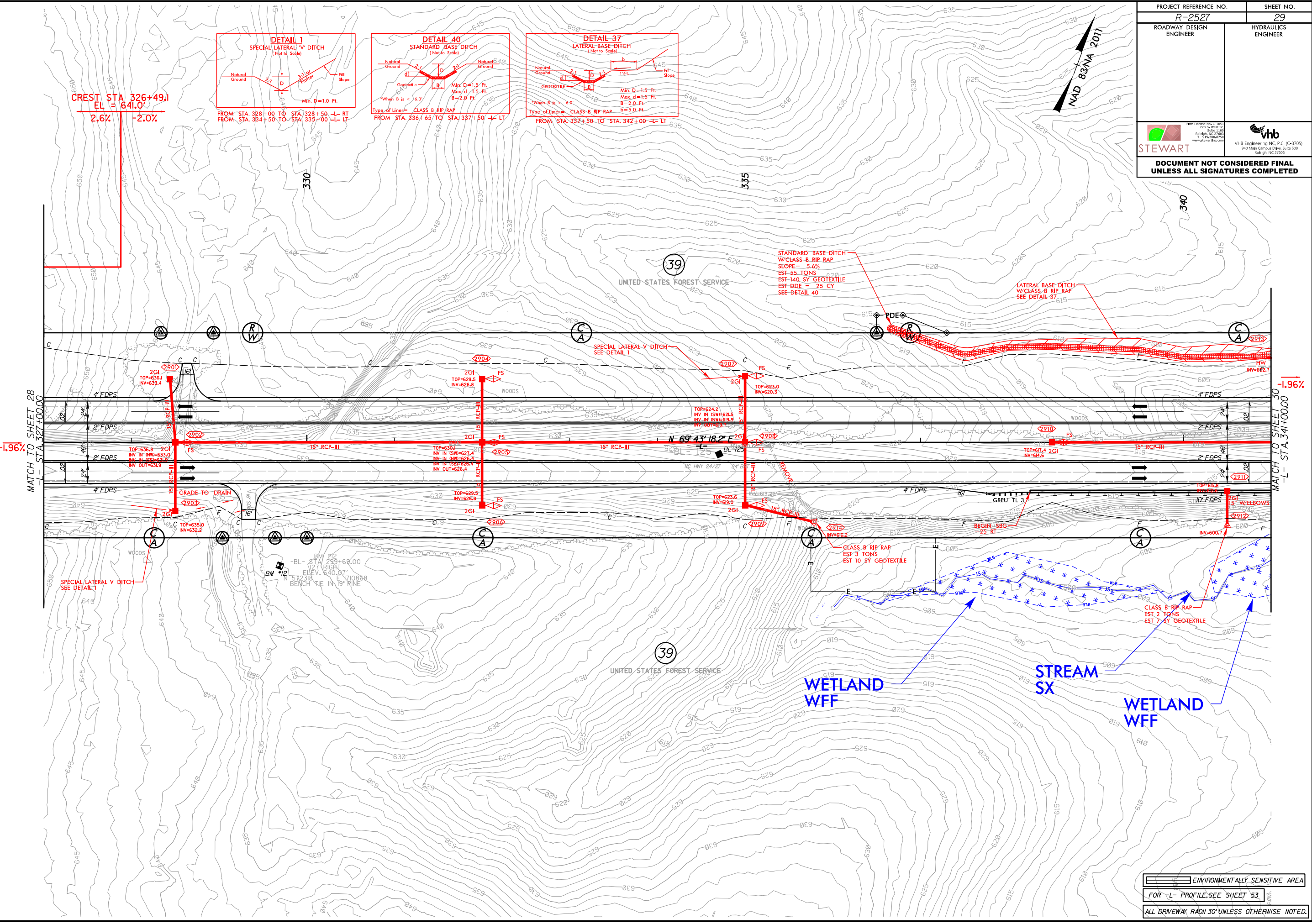

[Hatched Pattern]	ENVIRONMENTALLY SENSITIVE AREA
[Line]	FOR INTERSECTION DETAIL, SEE SHEET 28-6
[Line]	FOR -L- PROFILE, SEE SHEETS 52 & 53

5/14/99
 REVISIONS
 MATCH TO SHEET 28
 -L- STA. 327+00.00
 MATCH TO SHEET 30
 -L- STA. 341+00.00
 R:\hjd\psrh\PSH2527_Hjd_PSH29.dgn



ENVIRONMENTALLY SENSITIVE AREA
 FOR -L- PROFILE, SEE SHEET 53
 ALL DRIVEWAY RADII 30' UNLESS OTHERWISE NOTED.

5/14/99

PROJECT REFERENCE NO. R-2527	SHEET NO. 30
ROADWAY DESIGN ENGINEER	HYDRAULICS ENGINEER
 STEWART	 Vhb Vhb Engineering NC, P.C. (C-3705) 940 Main Campus Drive, Suite 500 Raleigh, NC 27606
DOCUMENT NOT CONSIDERED FINAL UNLESS ALL SIGNATURES COMPLETED	

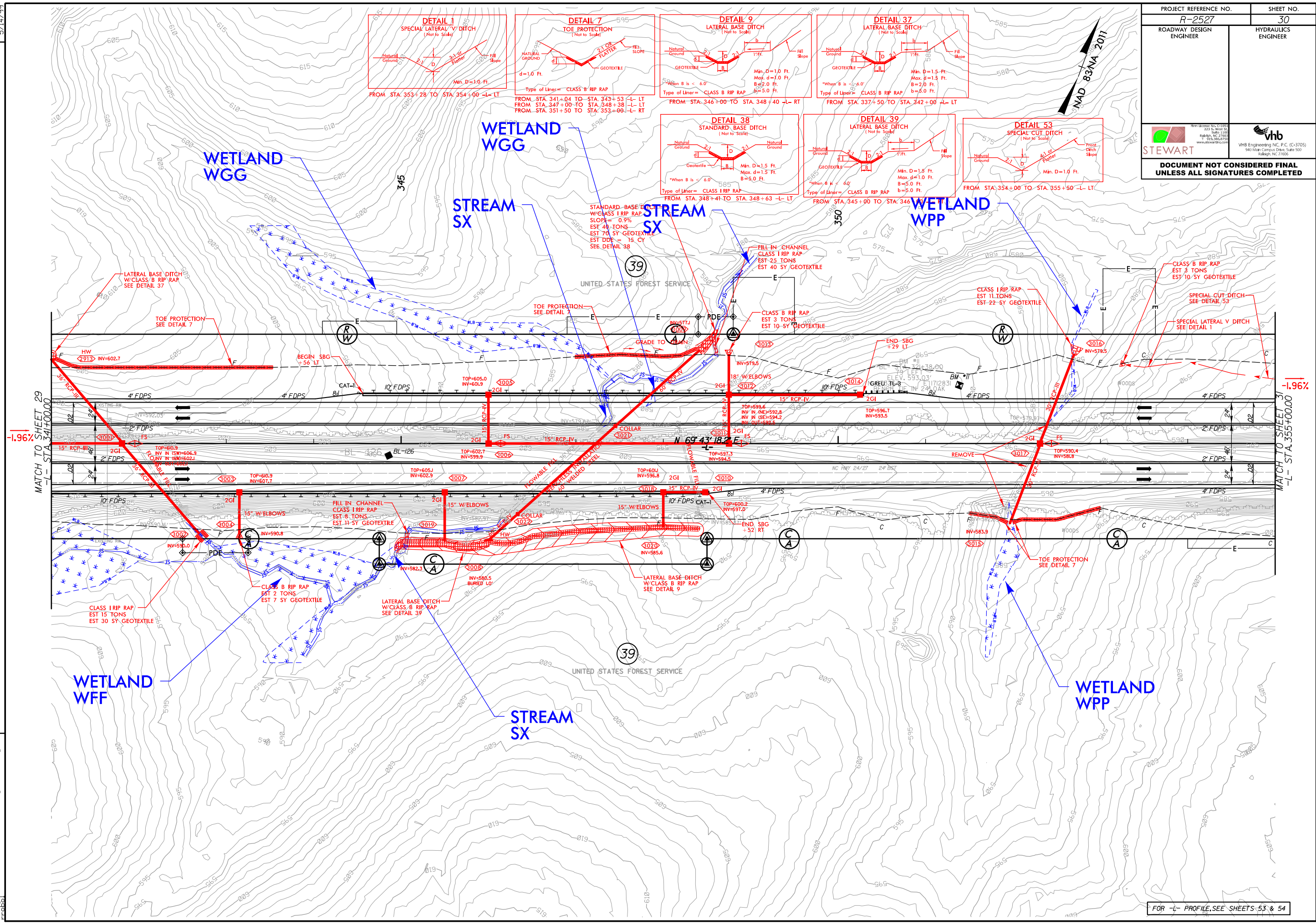

REVISIONS

R:\142\AM
8:14:21 AM
C:\Users\jrcs\CADD\PSH\R2527_Hyd_PSH30.dgn

FOR -L- PROFILE, SEE SHEETS 53 & 54

Pls Sta 362+32.11
 $\Delta s = 2' 23" 29.3"$
 $Ls = 240.00'$
 $LT = 160.01'$
 $ST = 80.01'$

PI Sta 370+20.61
 $\Delta = 27' 41" 17.0" (RT)$
 $D = 1' 59" 34.4"$
 $L = 1,389.34'$
 $T = 708.51'$
 $R = 2,875.00'$
 $S_b = 6\%$

Pls Sta 377+81.45
 $\Delta s = 2' 23" 29.3"$
 $Ls = 240.00'$
 $LT = 160.01'$
 $ST = 80.01'$

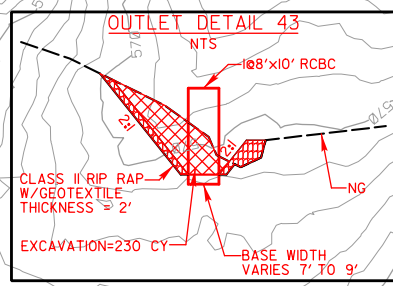
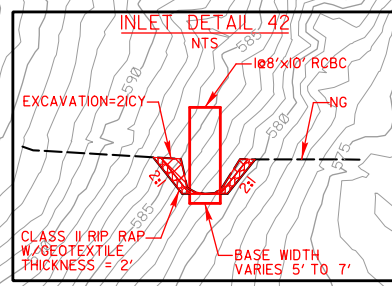
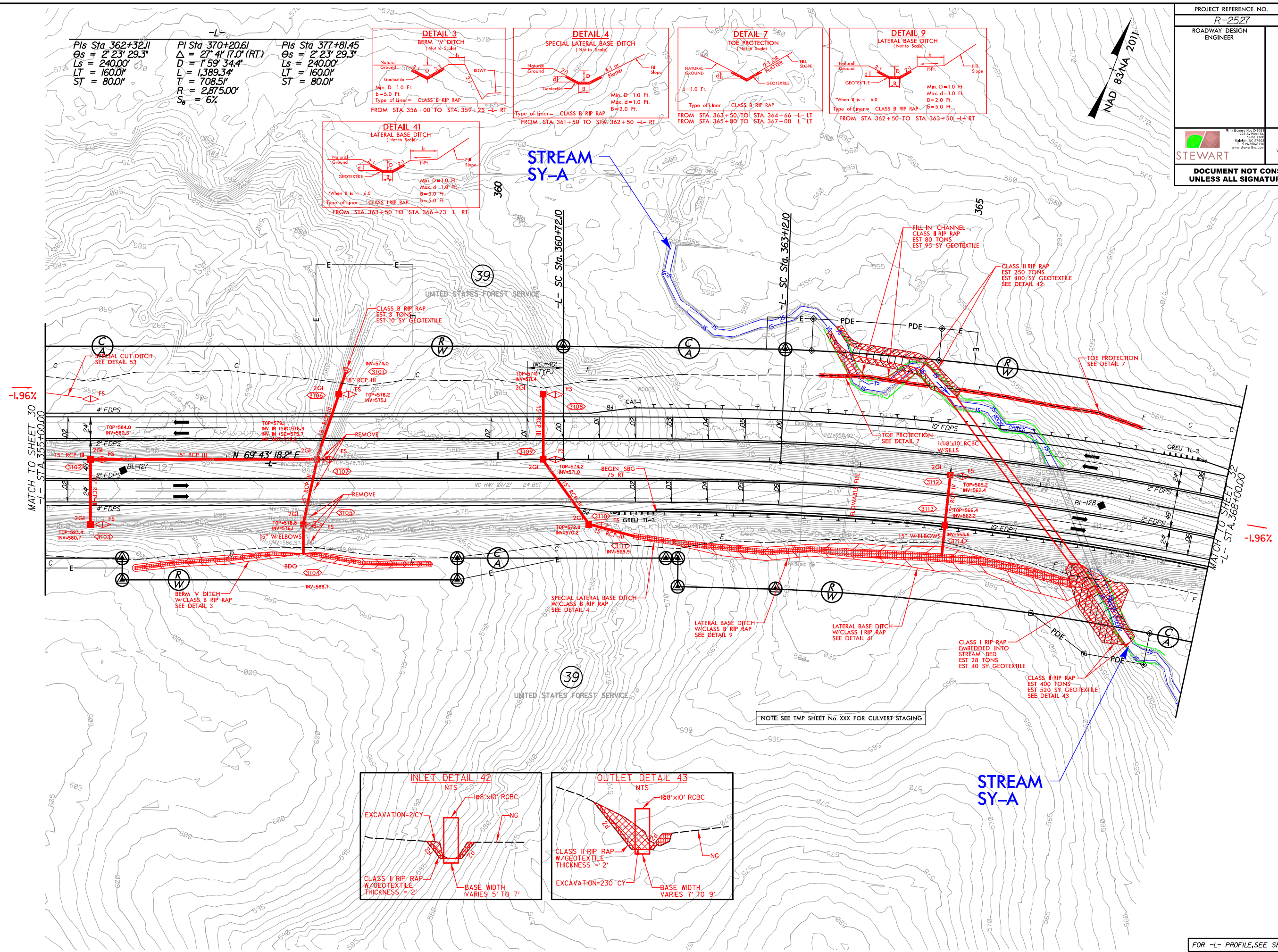
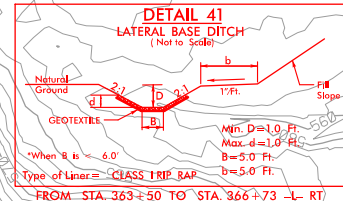
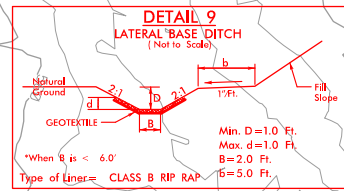
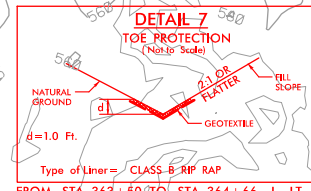
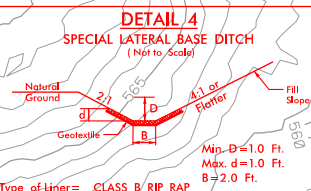
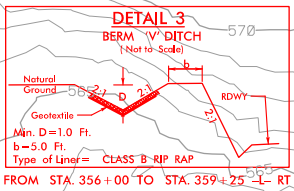

REVISIONS
 ROW REV. - May 20, 2019 - TCE label updated at -L- +92.00, 124.49 LT, 160.00 LT, (MSB)

8:40:30 AM
 R:\projects\cadd\PSH\R2527_Hyd_PSH31.dgn
 P:\ps\ps31

Pls Sta 362+32.11
 $\Theta_s = 2^\circ 23' 29.3"$
 $L_s = 240.00'$
 $LT = 160.01'$
 $ST = 80.01'$

Pls Sta 370+20.61
 $\Delta = 27^\circ 41' 17.0" (RT)$
 $D = 1^\circ 59' 34.4"$
 $L = 1,389.34'$
 $T = 708.51'$
 $R_s = 2,875.00'$
 $S_s = 6\%$

Pls Sta 377+81.45
 $\Theta_s = 2^\circ 23' 29.3"$
 $L_s = 240.00'$
 $LT = 160.01'$
 $ST = 80.01'$

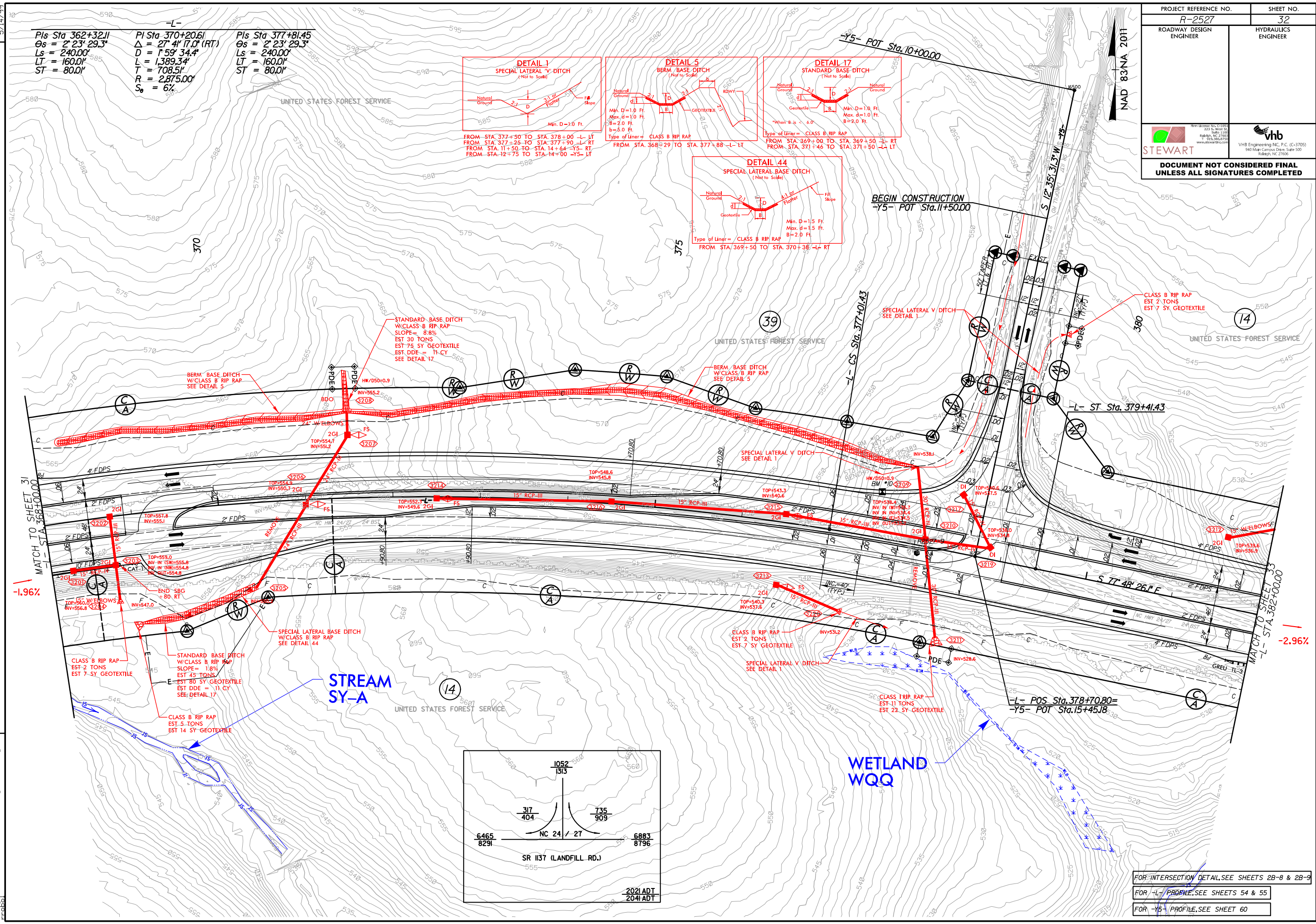
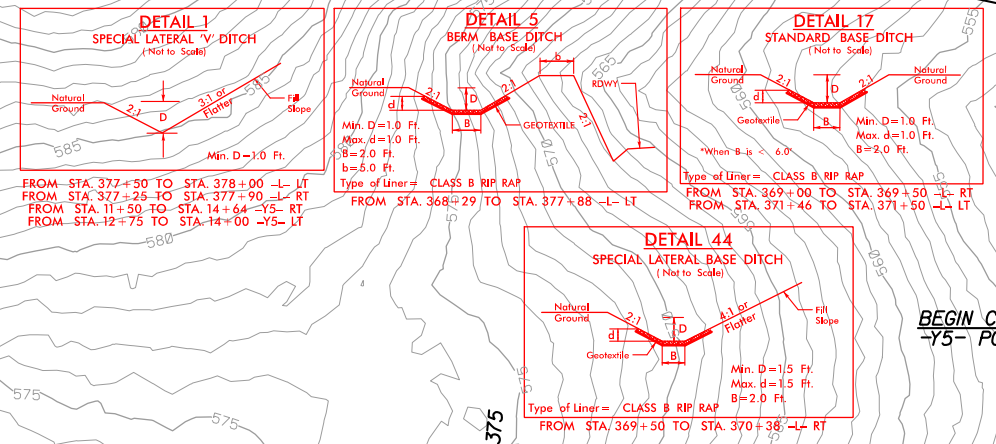

REVISIONS

8/10/23 5:36 AM
 R:\Projects\2527\CADD\PSH\R2527_Hyd_PSH32.dgn

FOR INTERSECTION DETAIL, SEE SHEETS 28-B & 28-9
 FOR -L- PROFILE, SEE SHEETS 54 & 55
 FOR -Y5- PROFILE, SEE SHEET 60

-L-

PIs Sta 362+32.11 Os = 2' 23" 29.3" Ls = 240.00' LT = 160.01' ST = 80.01'	PI Sta 370+20.61 Δ = 27' 41" 17.0" (RT) D = 1' 59" 34.4" L = 1,389.34' T = 708.51' R = 2,875.00' S _e = 6%	PIs Sta 377+81.45 Os = 2' 23" 29.3" Ls = 240.00' LT = 160.01' ST = 80.01'
---	--	---

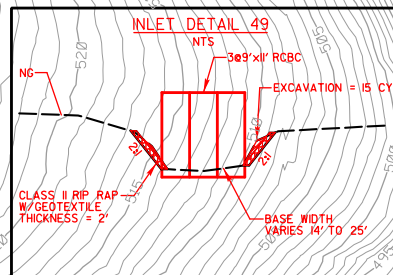
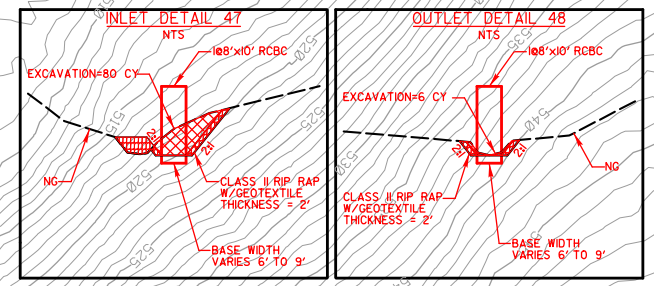
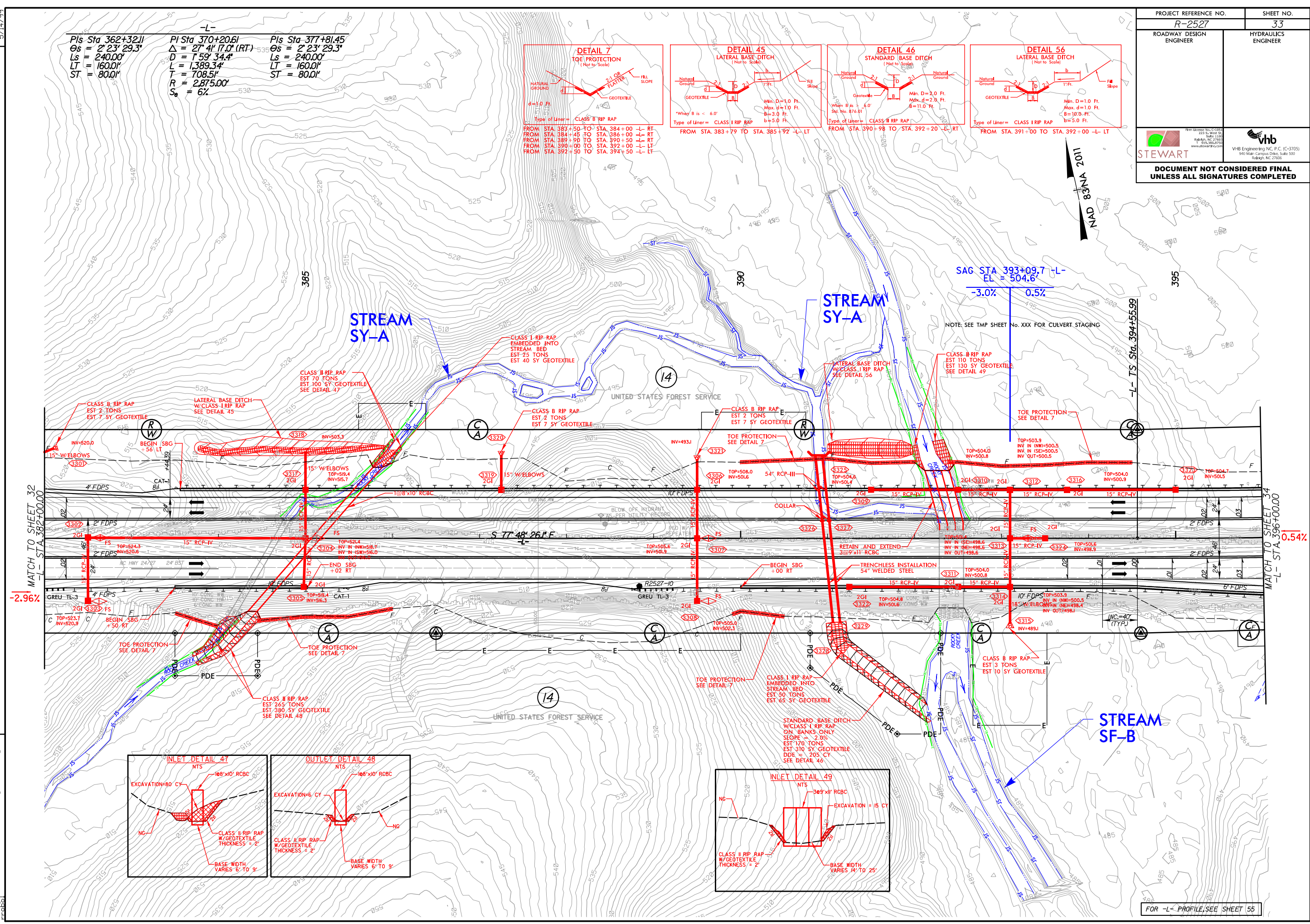
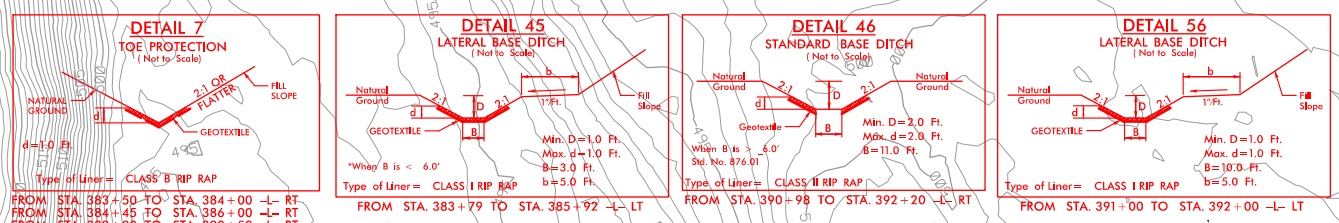

REVISIONS

8/10/16 AM
R:\Projects\Roadway\CADD\PSH\R2527_Hyd_PSH33.dgn

MATCH TO SHEET 32
-L- STA. 382+00.00

MATCH TO SHEET 34
-L- STA. 396+00.00

FOR -L- PROFILE, SEE SHEET 55

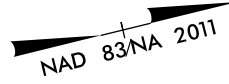

-L-
 Pls Sta 396+42.71
 $\Delta s = 4'13''18.5''$
 $Ls = 280.00'$
 $LT = 186.72'$
 $ST = 93.38'$

-L-
 Pls Sta 406+31.31
 $\Delta = 50'27''42.2''$ (LT)
 $D = 3'00''56.0''$
 $L = 167.33'$
 $T = 895.32'$
 $R = 1,900.00'$
 $S_0 = 7\%$

-L-
 Pls Sta 415+02.74
 $\Delta s = 4'13''18.5''$
 $Ls = 280.00'$
 $LT = 186.72'$
 $ST = 93.38'$

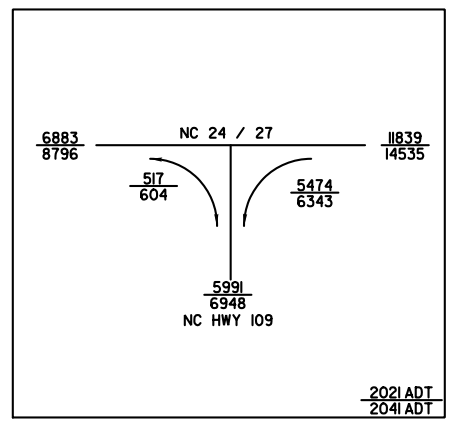
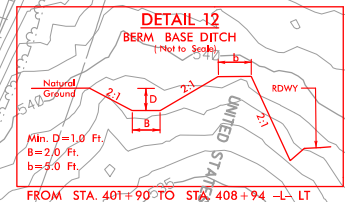

REVISIONS
 ROW REV. - April 4, 2019 - PUE added along Parcels 14 and 40.(MSB)
 TCE revised along Parcel 40.(MSB)

8:40:57 AM
 R:\Projects\2527\CADD\PSH\R2527_Hyd_PSH34.dgn

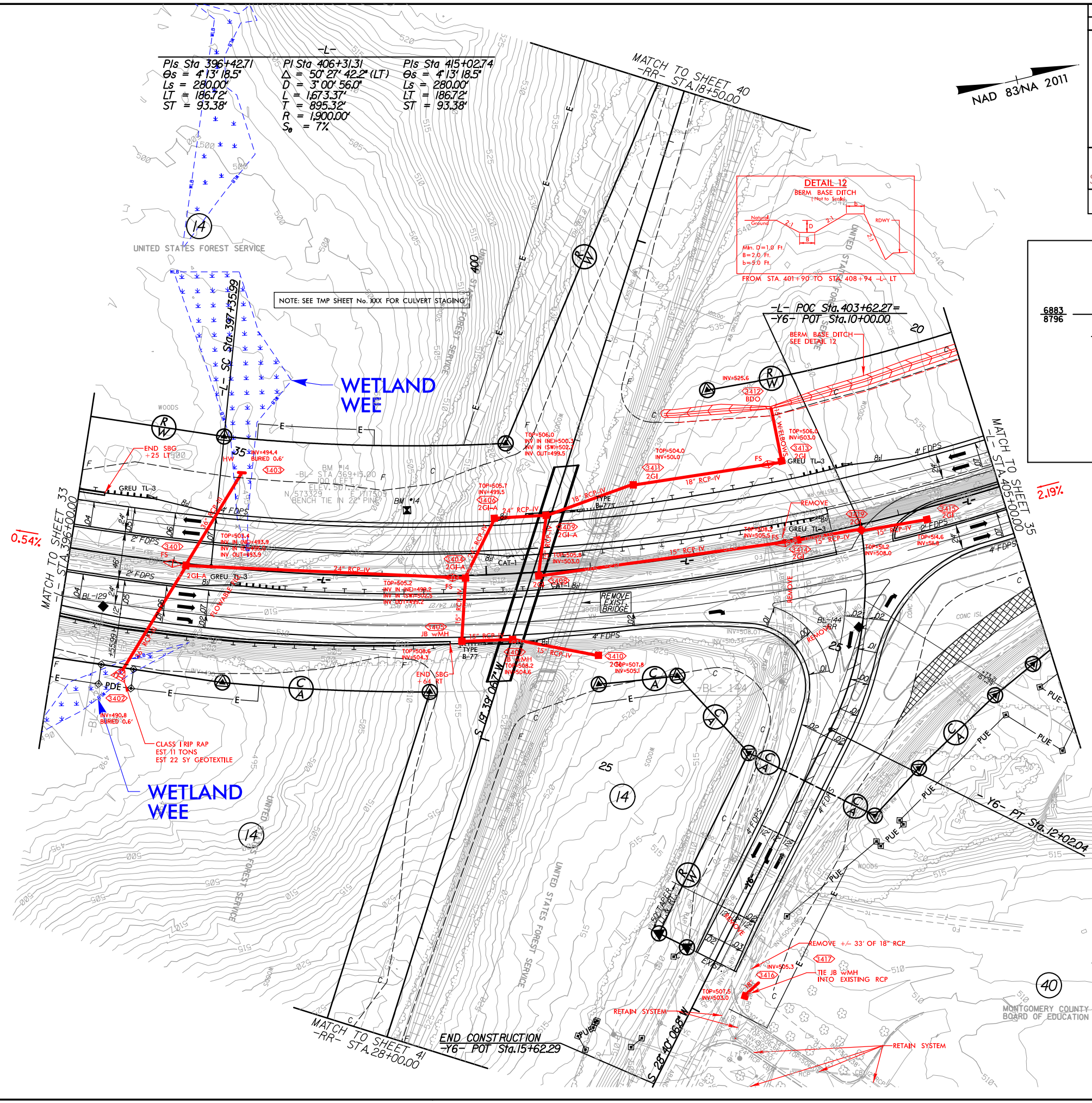

FOR INTERSECTION DETAIL, SEE SHEET 2B-10
 FOR -L- PROFILE, SEE SHEETS 55 & 56
 FOR -Y6- PROFILE, SEE SHEET 61
 FOR -RR- PROFILE, SEE SHEET 62



Pls Sta 396+42.71 $\Theta_s = 4'13''18.5''$ $L_s = 280.00'$ $LT = 186.72'$ $ST = 93.38'$	Pls Sta 406+31.31 $\Delta = 50'27''42.2''(LT)$ $D = 55'00''56.0''$ $L = 167.33'$ $T = 895.32'$ $R = 1900.00'$ $S_0 = 7\%$	Pls Sta 415+02.74 $\Theta_s = 4'13''18.5''$ $L_s = 280.00'$ $LT = 186.72'$ $ST = 93.38'$
--	---	--

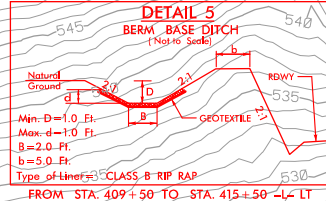
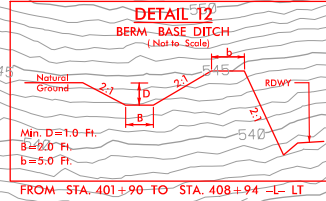

CREST STA 408+34.5 -L-
EL = 519.3'
2.5% -1.7%

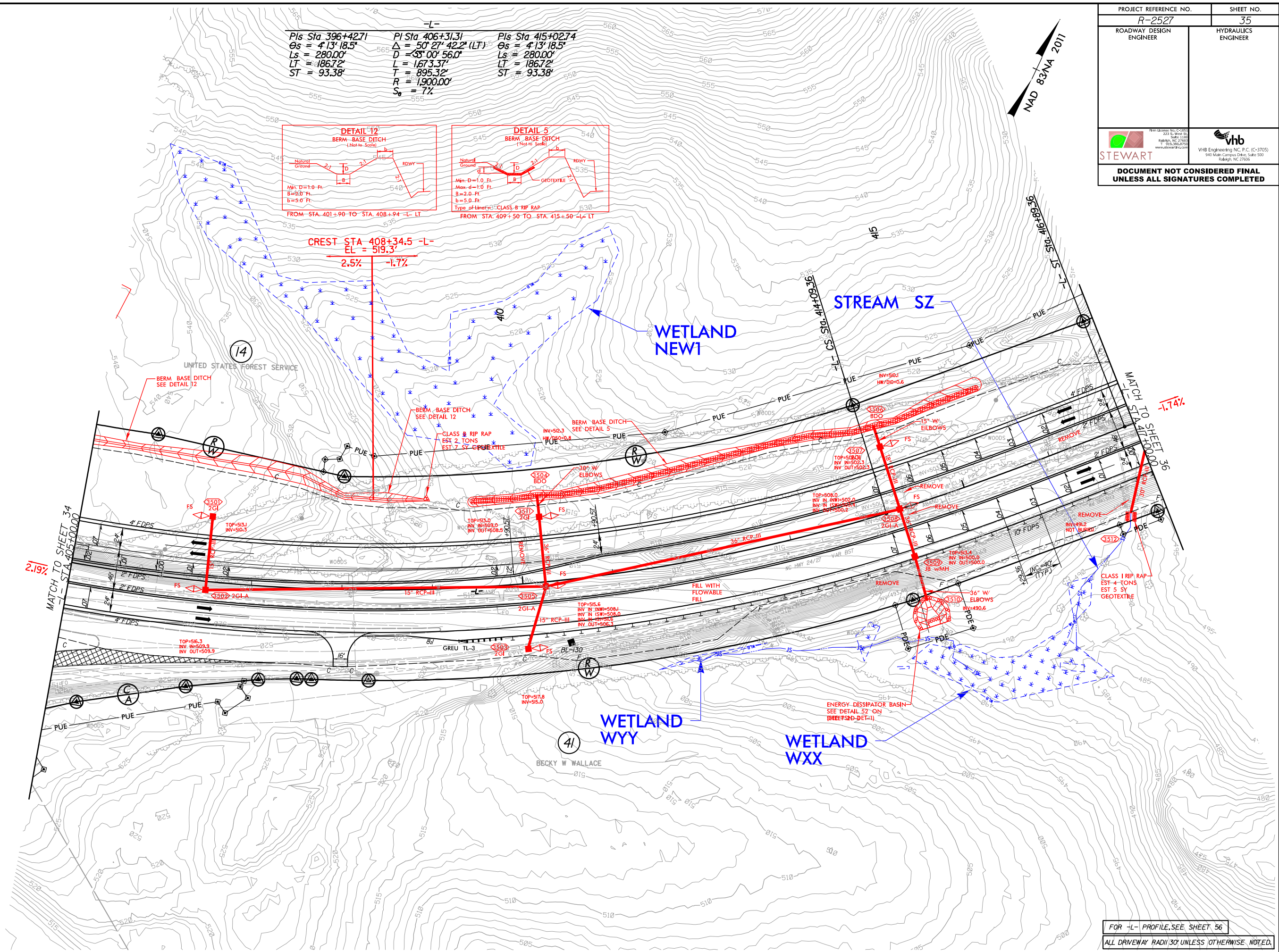

REVISIONS
 ROW REV. - April 4, 2019 - PUE added along Parcel 41, PUE revised along Parcel 41, (MSB)
 ROW REV. - May 20, 2019 - ROW label added at -L- +7500, 15500' LI, (MSB)
 ROW REV. - May 27, 2019 - PUE label revised at -L- +4500, 9892' RT, 11000' RT, (MSB)

B:\Hid\Projects\CADD\PSH\R2527_Hyd_PSH35.dgn
 5/14/19

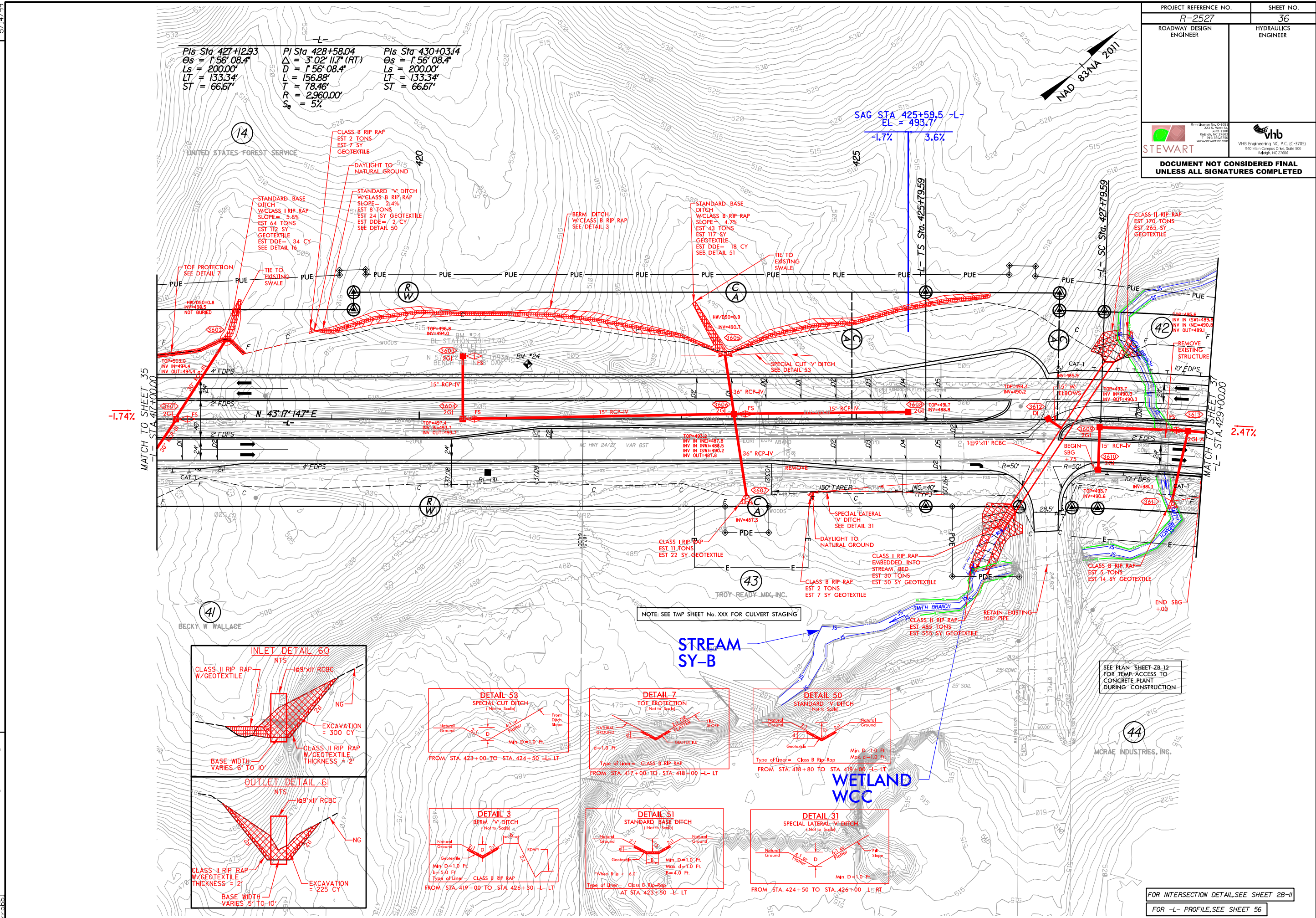

Pls Sta 427+12.93
 $\Delta s = 1'56''08.4''$
 $Ls = 200.00'$
 $LT = 133.34'$
 $ST = 66.67'$

Pls Sta 428+58.04
 $\Delta = 3'02''11.7'' (RT)$
 $D = 1'56''08.4''$
 $L = 156.88'$
 $T = 78.46'$
 $R = 2,960.00'$
 $S_0 = 5\%$

Pls Sta 430+03.14
 $\Delta s = 1'56''08.4''$
 $Ls = 200.00'$
 $LT = 133.34'$
 $ST = 66.67'$

SAG STA 425+59.5 -L-
EL = 493.7'

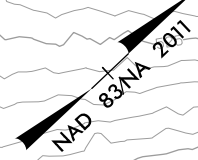

MATCH TO SHEET 35
-L- STA 417+00.00

MATCH TO SHEET 37
-L- STA 429+00.00

REVISIONS
ROW REV. - April 4, 2019 - PUE revised along Parcels 14 and 42 (MSB)

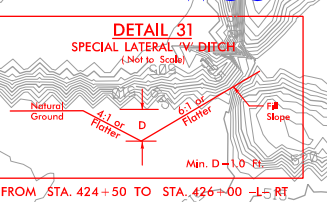
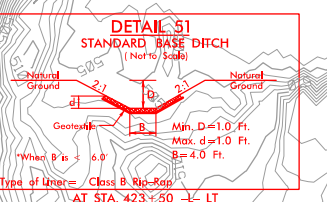
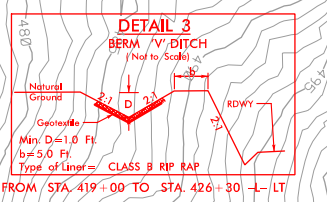
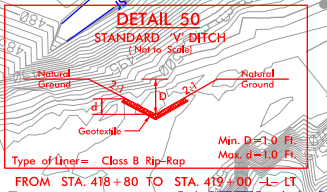
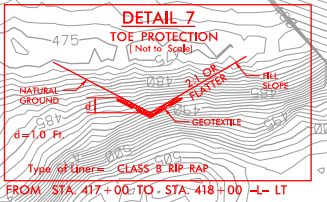
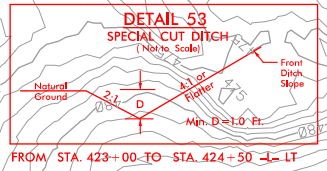
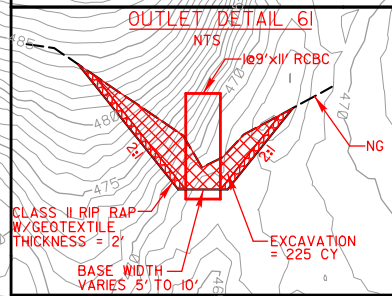
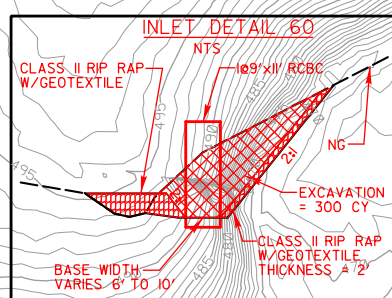

NOTE: SEE TAMP SHEET No. XXX FOR CULVERT STAGING

SEE PLAN SHEET 2B-12 FOR TEMP. ACCESS TO CONCRETE PLANT DURING CONSTRUCTION

FOR INTERSECTION DETAIL, SEE SHEET 2B-II
FOR -L- PROFILE, SEE SHEET 56

BAH:AM
B:\Hyd\baures\CADD\PSH\R2527_Hyd_PSH36.dgn
5/14/99

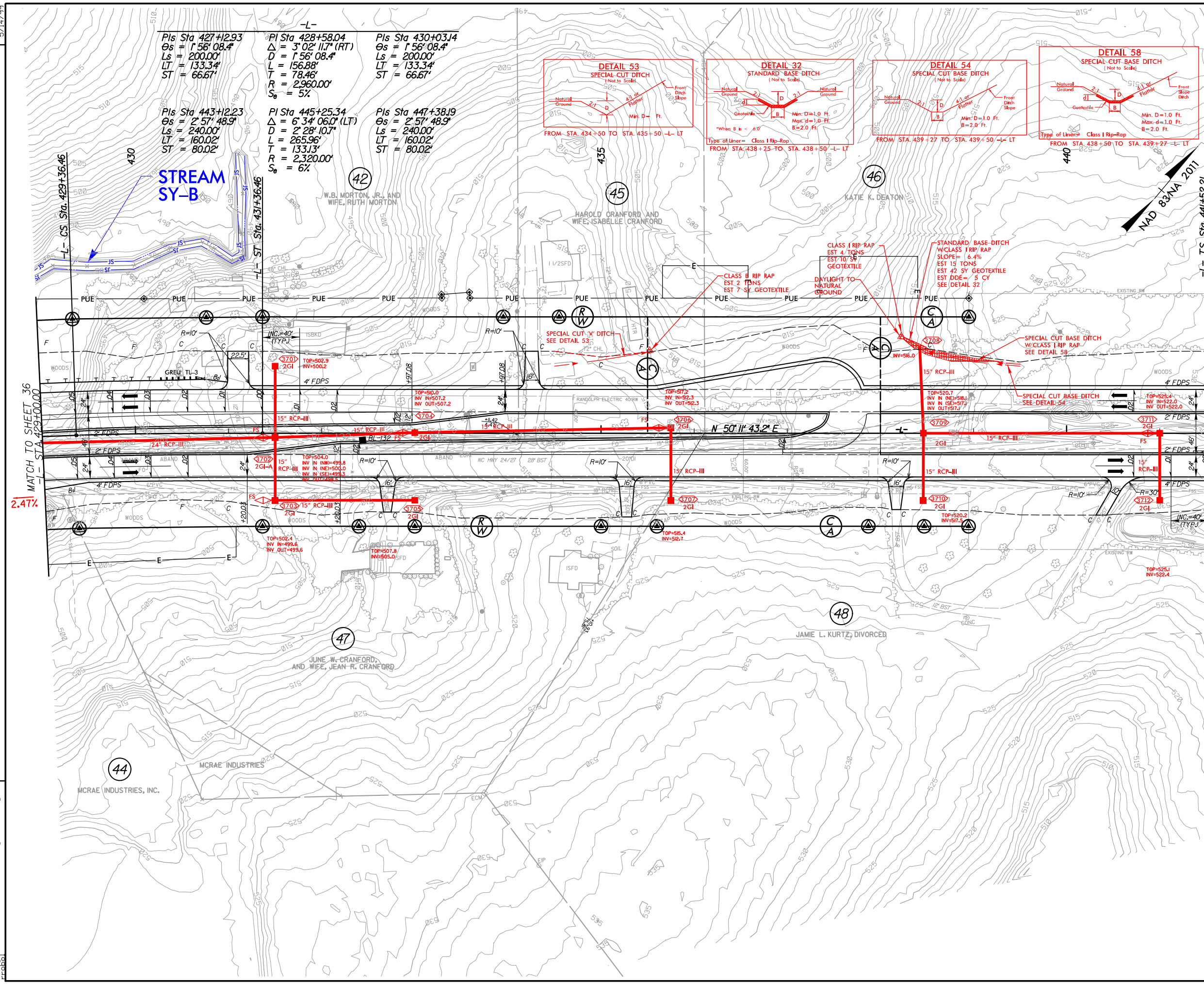

Pls Sta 427+12.93
 $\Theta_s = 1'56''08.4''$
 $L_s = 200.00'$
 $LT = 133.34'$
 $ST = 66.67'$

Pls Sta 428+58.04
 $\Delta = 3'02''11.7'' (RT)$
 $D = 156.88'$
 $T = 78.46'$
 $R = 2,960.00'$
 $S_0 = 5\%$

Pls Sta 430+03.14
 $\Theta_s = 1'56''08.4''$
 $L_s = 200.00'$
 $LT = 133.34'$
 $ST = 66.67'$

Pls Sta 443+12.23
 $\Theta_s = 2'57''48.9''$
 $L_s = 240.00'$
 $LT = 160.02'$
 $ST = 80.02'$

Pls Sta 445+25.34
 $\Delta = 6'34''06.0'' (LT)$
 $D = 2'28''10.7''$
 $L = 265.96'$
 $T = 133.33'$
 $R = 2,320.00'$
 $S_0 = 6\%$

Pls Sta 447+38.19
 $\Theta_s = 2'57''48.9''$
 $L_s = 240.00'$
 $LT = 160.02'$
 $ST = 80.02'$

REVISIONS
 ROW REV. - April 4, 2019 - PUE revised along Parcels 42, 45 and 46. (MSB)

5/14/99
 R:\H2\Projects\CADD\PSH\R2527_Hyd_PSH37.dgn
 8:42:37 AM

FOR INTERSECTION DETAIL, SEE SHEET 2B-II
 FOR -L- PROFILE, SEE SHEETS 56 & 57

5/14/99

Pls Sta 443+12.23	Pls Sta 445+25.34	Pls Sta 447+38.19
$\theta_s = 2' 57'' 48.9''$	$\Delta = 6' 34'' 06.0'' (LT)$	$\theta_s = 2' 57'' 48.9''$
$L_s = 240.00'$	$D = 2' 28'' 10.7''$	$L_s = 240.00'$
$LT = 160.02'$	$L = 265.96'$	$LT = 160.02'$
$ST = 80.02'$	$T = 133.13'$	$ST = 80.02'$
	$R = 2320.00'$	
	$S_o = 6\%$	

PROJECT REFERENCE NO. R-2527	SHEET NO. 38
ROADWAY DESIGN ENGINEER	HYDRAULICS ENGINEER
DOCUMENT NOT CONSIDERED FINAL UNLESS ALL SIGNATURES COMPLETED	

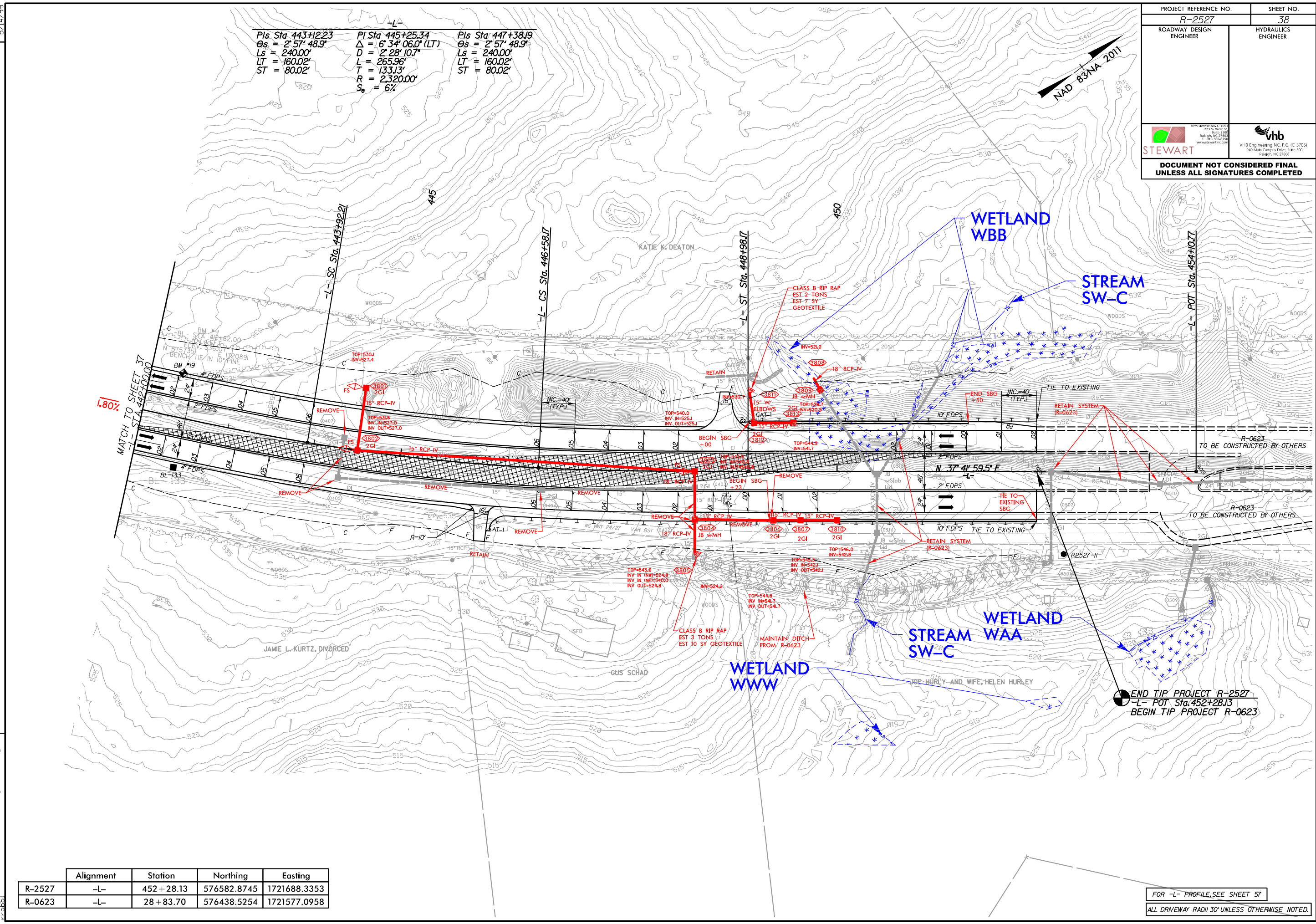

REVISIONS



	Alignment	Station	Northing	Easting
R-2527	-L-	452 + 28.13	576582.8745	1721688.3353
R-0623	-L-	28 + 83.70	576438.5254	1721577.0958

FOR -L- PROFILE, SEE SHEET 57
ALL DRIVEWAY RADII 30' UNLESS OTHERWISE NOTED.

R:\4135 AM\Projects\Hydraulics\CADD\PSH\R2527_Hyd_PSH38.dgn
 5/14/99

PROJECT REFERENCE NO. R-2527	SHEET NO. 39
ROADWAY DESIGN ENGINEER	HYDRAULICS ENGINEER
 STEWART <small>1000 S. West St. Raleigh, NC 27601 www.stewartinc.com</small>	 VHB <small>VHB Engineering NC, P.C. (C-3705) 540 Main Campus Drive, Suite 500 Raleigh, NC 27606</small>
DOCUMENT NOT CONSIDERED FINAL UNLESS ALL SIGNATURES COMPLETED	

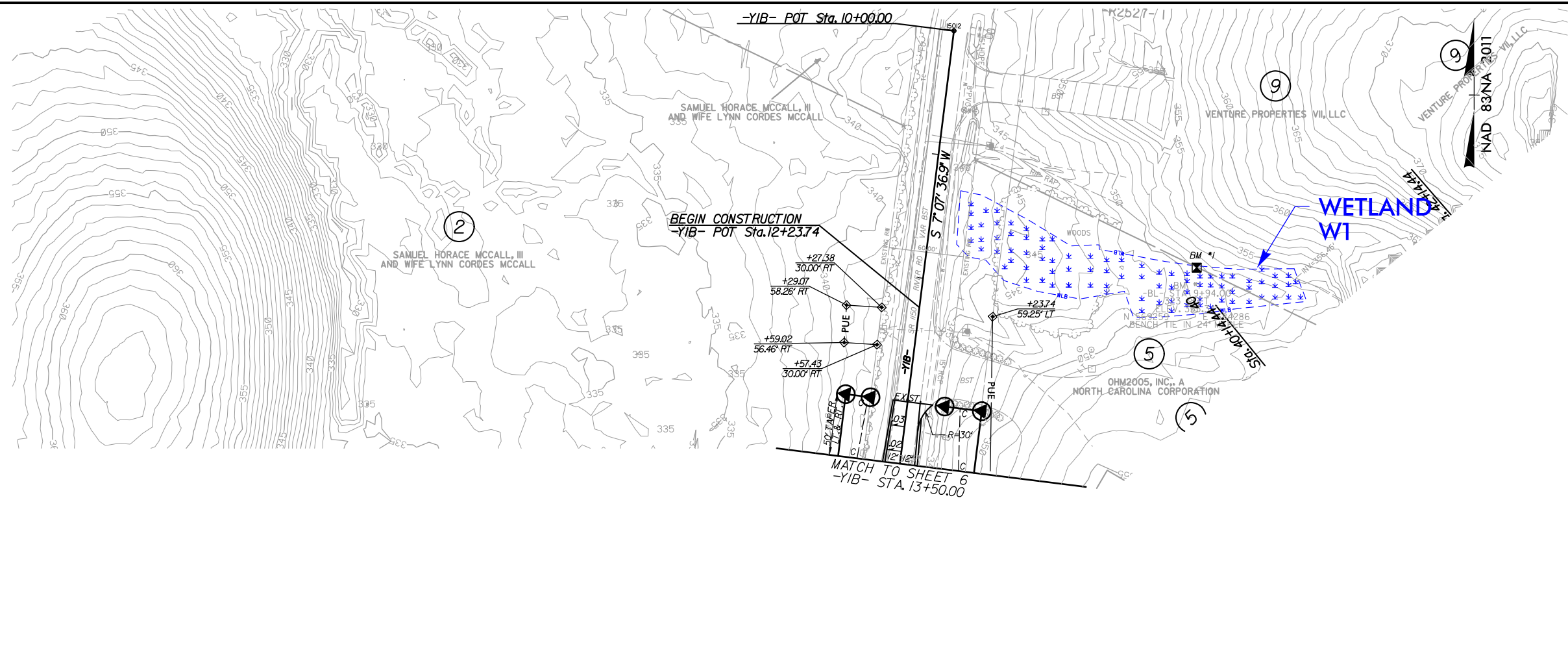

FOR -Y1B- PROFILE, SEE SHEET 58

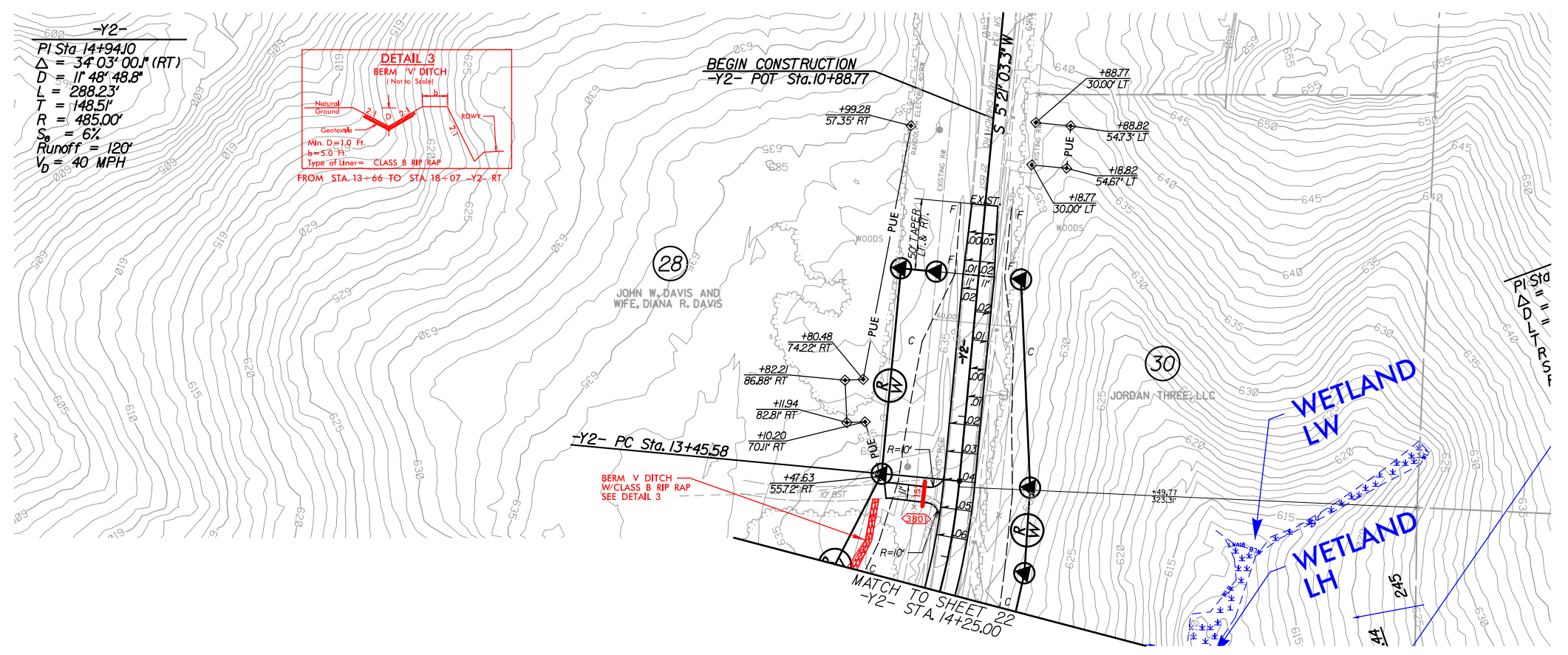



FOR -Y2- PROFILE, SEE SHEET 59

REVISIONS
 ROW REV. - April 4, 2019 - PUE added along Parcels 2 and 30.(MSB)
 PUE revised along Parcels 5 and 28.(MSB)
 ROW REV. - May 20, 2019 - ROW label added at -Y1B- +00.00, 30.00' LT, 60.00' LT.(MSB)
 5/14/19
 R:\Hyd\Projects\CADD\PSH\R2527_Hyd_PSH39.dgn
 4:43 AM



5/14/99

-RR- CURVE DATA (CHORD DEFINITION)

PIs Sta 12+62.00	PI/Sta 15+18.42	PIs Sta 17+72.77
$\theta_s = 1^\circ 23' 42.0''$	$\Delta = 13^\circ 27' 46.5''$ (RT)	$\theta_s = 1^\circ 23' 42.0''$
$L_s = 93.00'$	$D = 3^\circ 00' 00.0''$	$L_s = 93.00'$
$LT = 62.00'$	$L = 448.76'$	$LT = 62.00'$
$ST = 31.00'$	$T = 225.42'$	$ST = 31.00'$
	$R = 1,909.86'$	
	$Ea = 1\frac{1}{2}''$	
	$Eu = 1\frac{3}{4}''$	
	$DS = 40$ MPH	

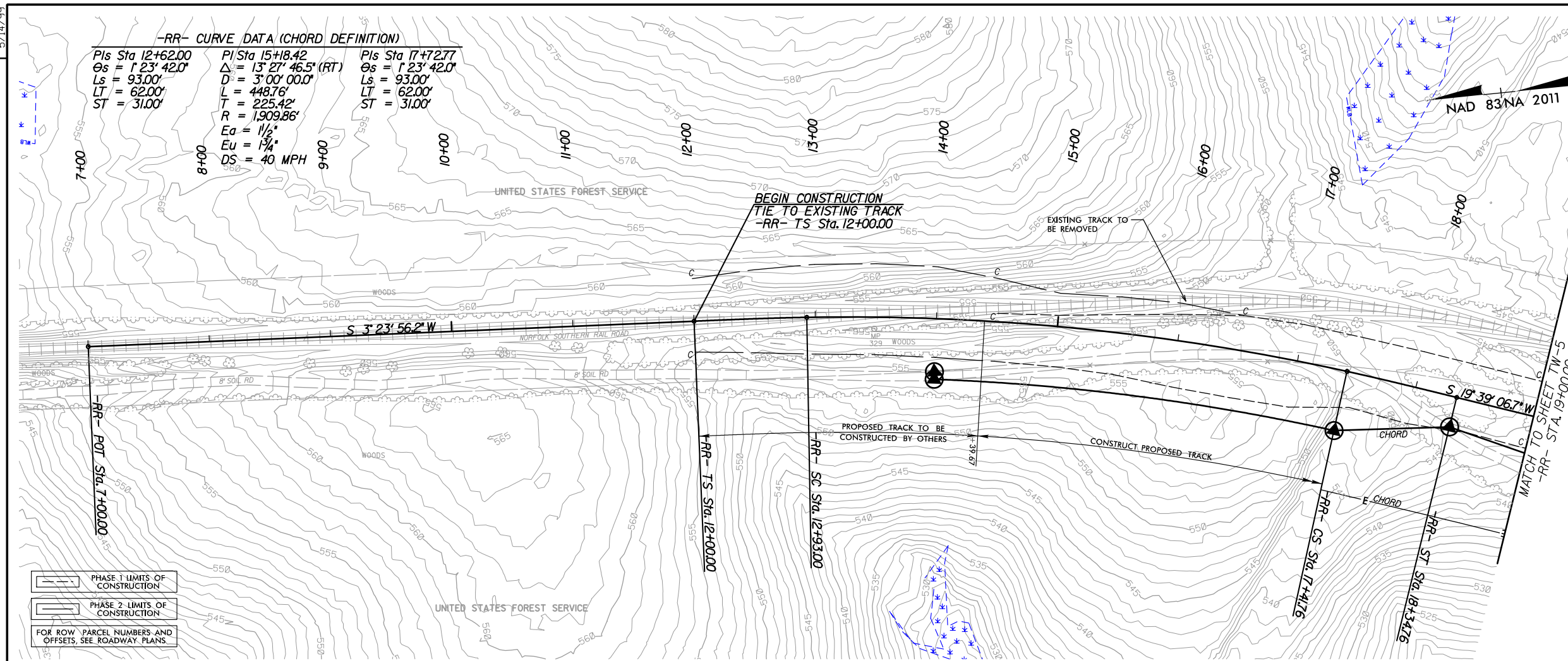
PROJECT REFERENCE NO. R-2527	SHEET NO. TW-4
Milepost 329.19	
ROADWAY DESIGN ENGINEER	HYDRAULICS ENGINEER
INCOMPLETE PLANS DO NOT USE FOR R/W ACQUISITION	
 STEWART	 VHB Engineering NC, P.C. (C-3705) 940 Main Campus Drive, Suite 500 Raleigh, NC 27605
DOCUMENT NOT CONSIDERED FINAL UNLESS ALL SIGNATURES COMPLETED	



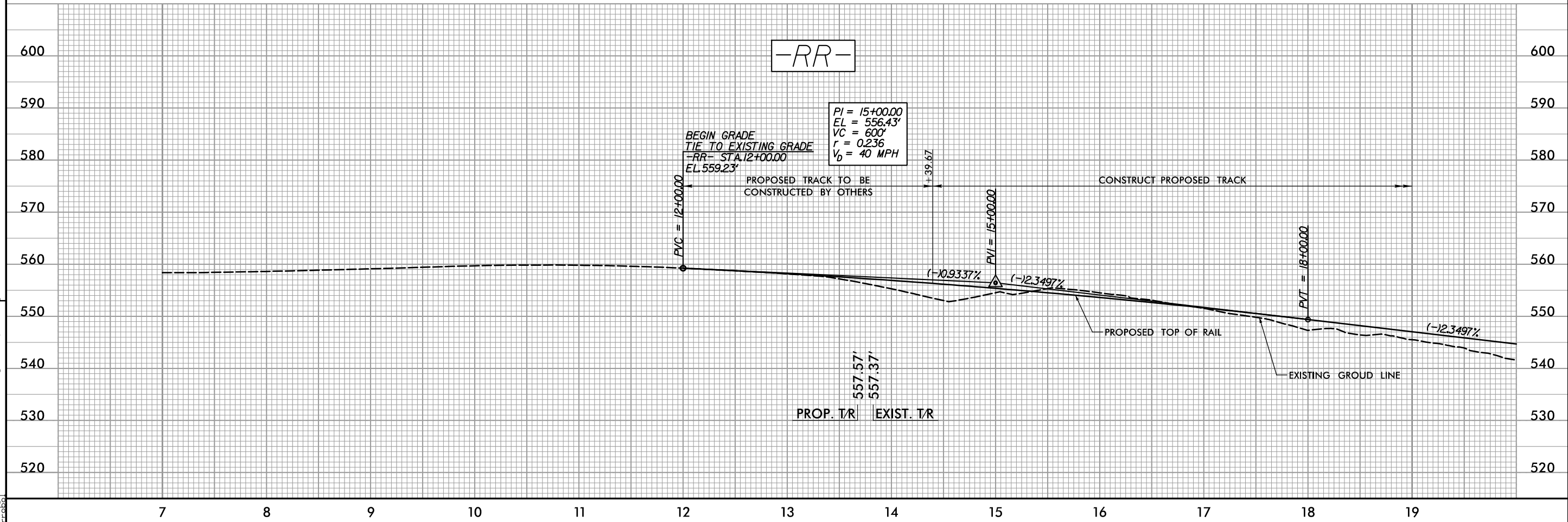

-  PHASE 1 LIMITS OF CONSTRUCTION
-  PHASE 2 LIMITS OF CONSTRUCTION
- FOR ROW, PARCEL NUMBERS AND OFFSETS, SEE ROADWAY PLANS

REVISIONS





R:\H2E2 AM\B\Hydro\Bulines\CADD\PSH\2527_Hyd_Rail_psh04.dgn

5/14/99

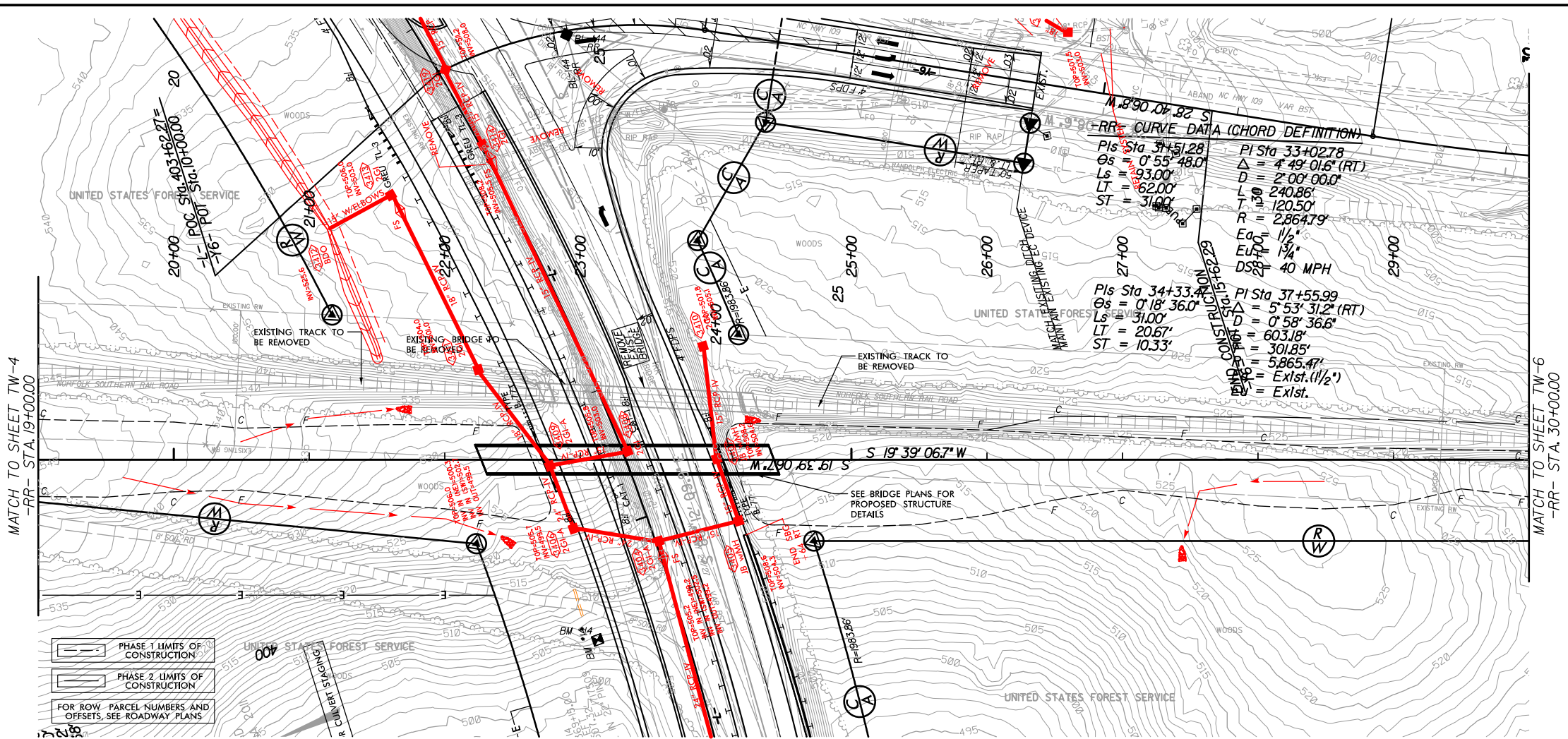
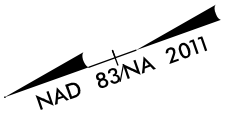
PROJECT REFERENCE NO. R-2527	SHEET NO. TW-5
Milepost 329.19	
ROADWAY DESIGN ENGINEER	HYDRAULICS ENGINEER
INCOMPLETE PLANS DO NOT USE FOR R/W ACQUISITION	
 STEWART	 vhb VHB Engineering NC, P.C. (C-3705) 940 Main Campus Drive, Suite 500 Raleigh, NC 27605
DOCUMENT NOT CONSIDERED FINAL UNLESS ALL SIGNATURES COMPLETED	



 PHASE 1 LIMITS OF CONSTRUCTION
 PHASE 2 LIMITS OF CONSTRUCTION
 FOR ROW, PARCEL NUMBERS AND OFFSETS, SEE ROADWAY PLANS

MATCH TO SHEET TW-4
-RR- STA. 19+00.00

MATCH TO SHEET TW-6
-RR- STA. 30+00.00

REVISIONS

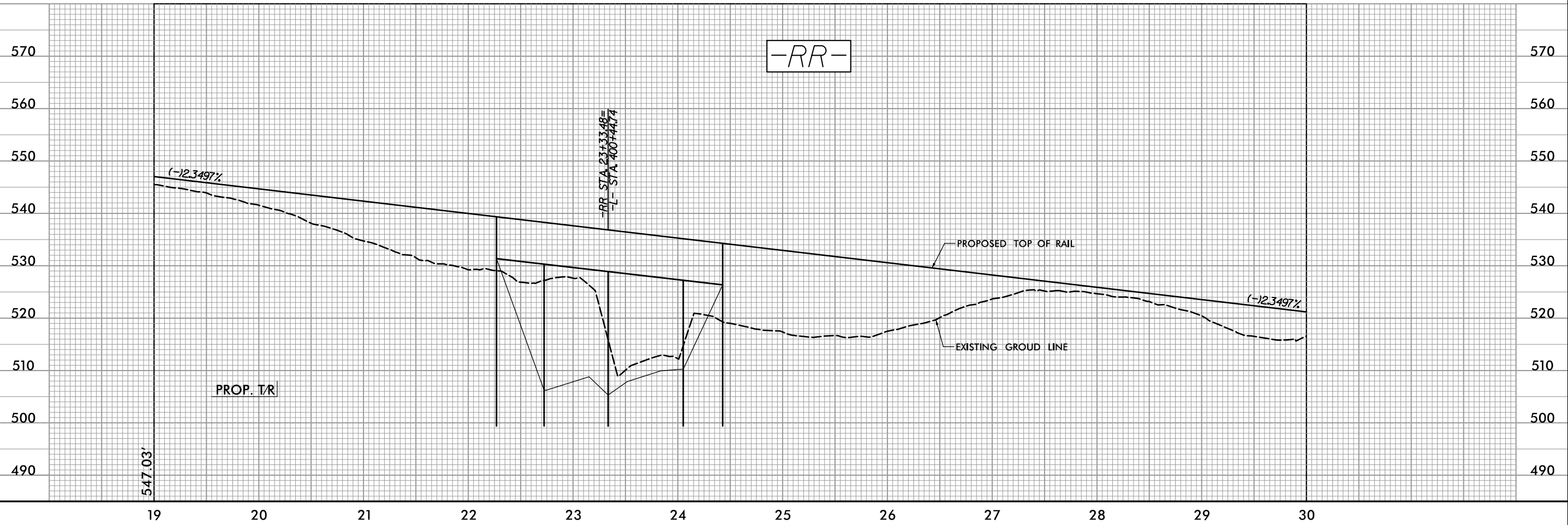

R:\Highways\cadd\PSH\2527_Hyd_Rail_psh05.dgn
 5/14/99 AM

5/14/99

PROJECT REFERENCE NO. <i>R-2527</i>	SHEET NO. <i>TW-6</i>
Milepost 329.19	
ROADWAY DESIGN ENGINEER	HYDRAULICS ENGINEER
INCOMPLETE PLANS DO NOT USE FOR R/W ACQUISITION	
DOCUMENT NOT CONSIDERED FINAL UNLESS ALL SIGNATURES COMPLETED	

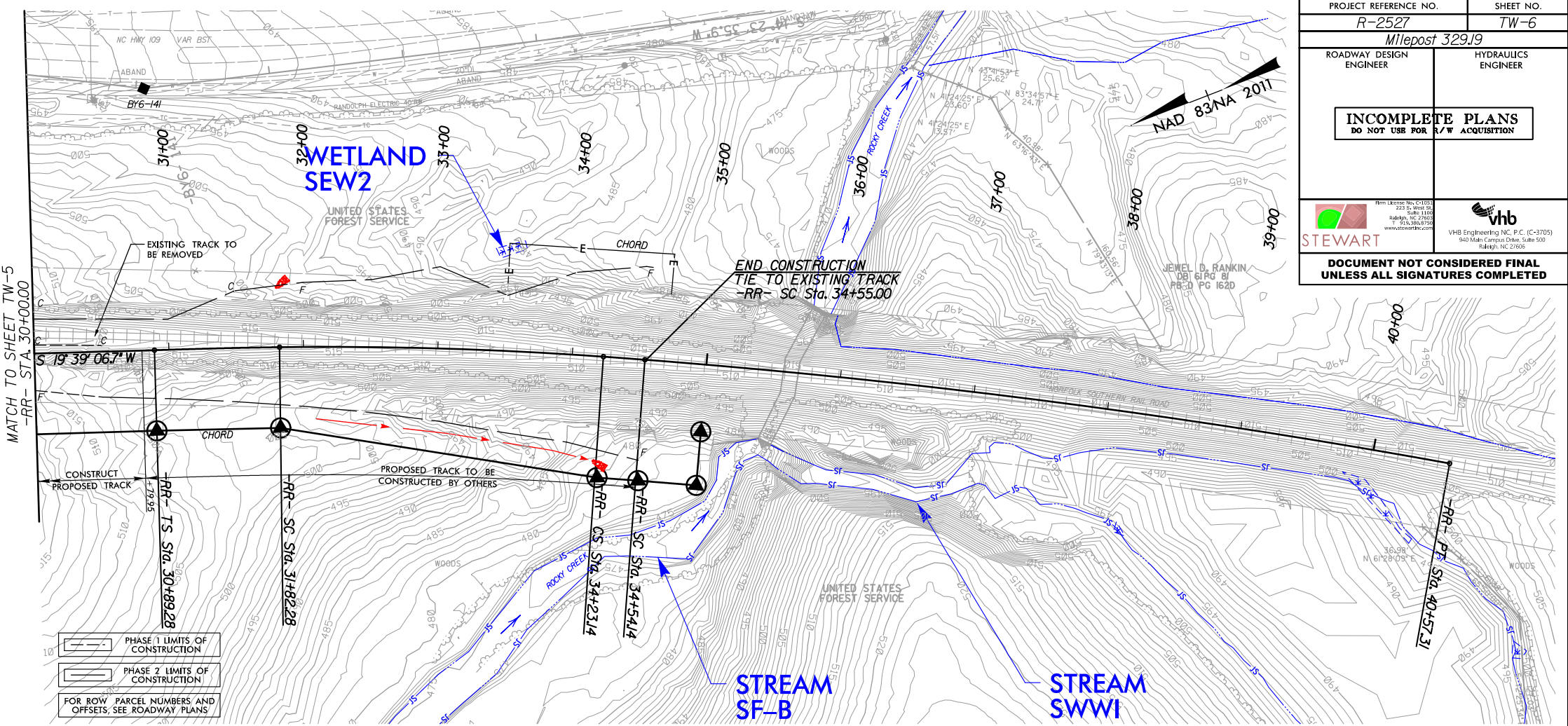

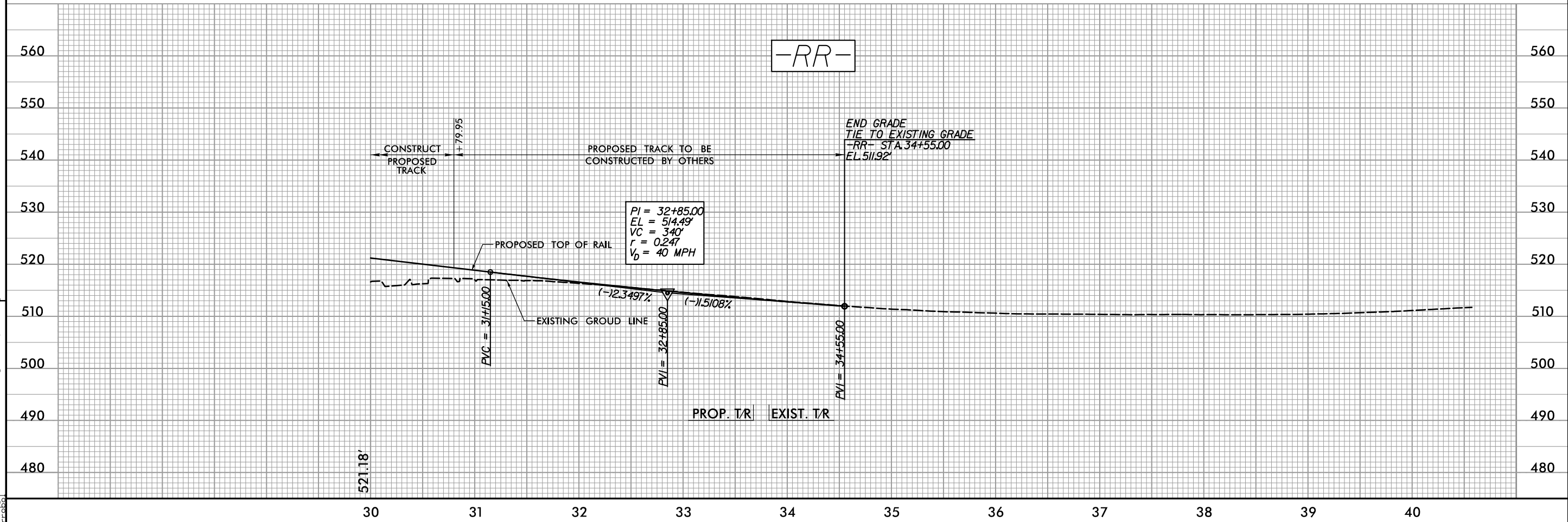

REVISIONS



R:\2003 AM\Projects\Rail\PSH\R2527_Hyd_Rail_psh06.dgn

5/14/99

PROJECT REFERENCE NO. <i>R-2527</i>	SHEET NO. <i>42</i>
ROADWAY DESIGN ENGINEER	HYDRAULICS ENGINEER
 STEWART Firm License No. C-2527 223 S. West St. Raleigh, NC 27603 P: 919.386.0700 www.stewartinc.com	 vhb VHB Engineering NC, P.C. (C-3705) 940 Main Campus Drive, Suite 500 Raleigh, NC 27606
DOCUMENT NOT CONSIDERED FINAL UNLESS ALL SIGNATURES COMPLETED	

REVISIONS

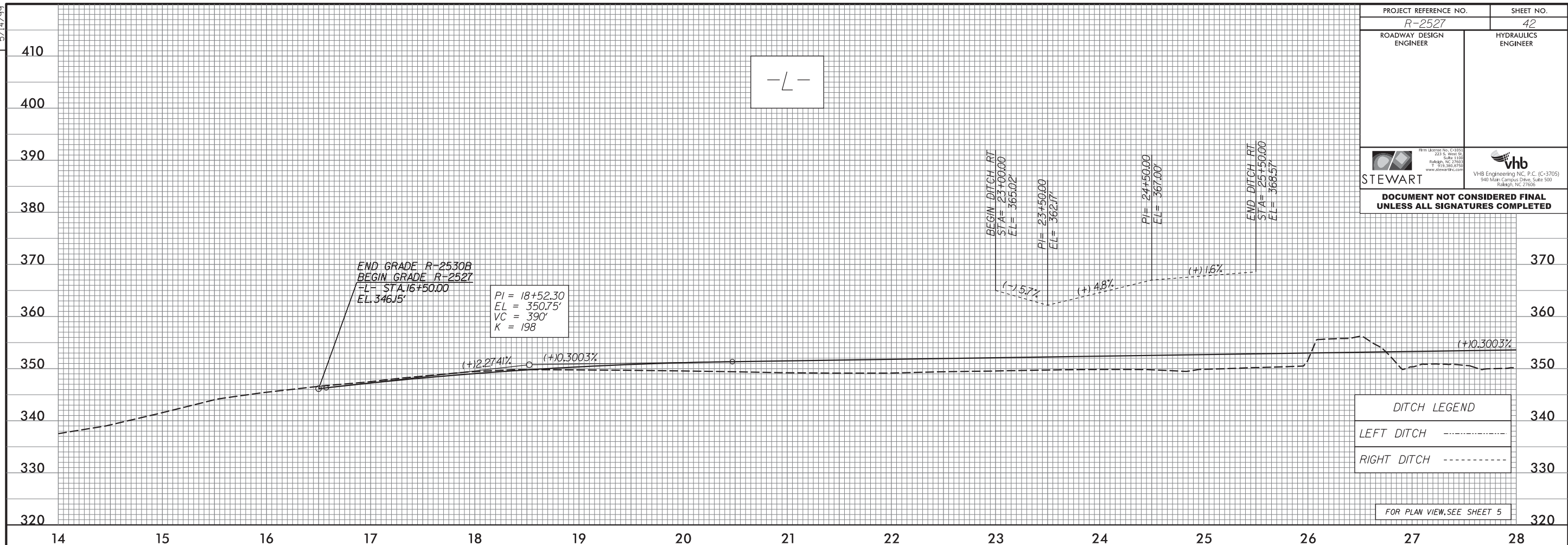

DITCH LEGEND	
LEFT DITCH	-----
RIGHT DITCH	-----

FOR PLAN VIEW, SEE SHEET 5

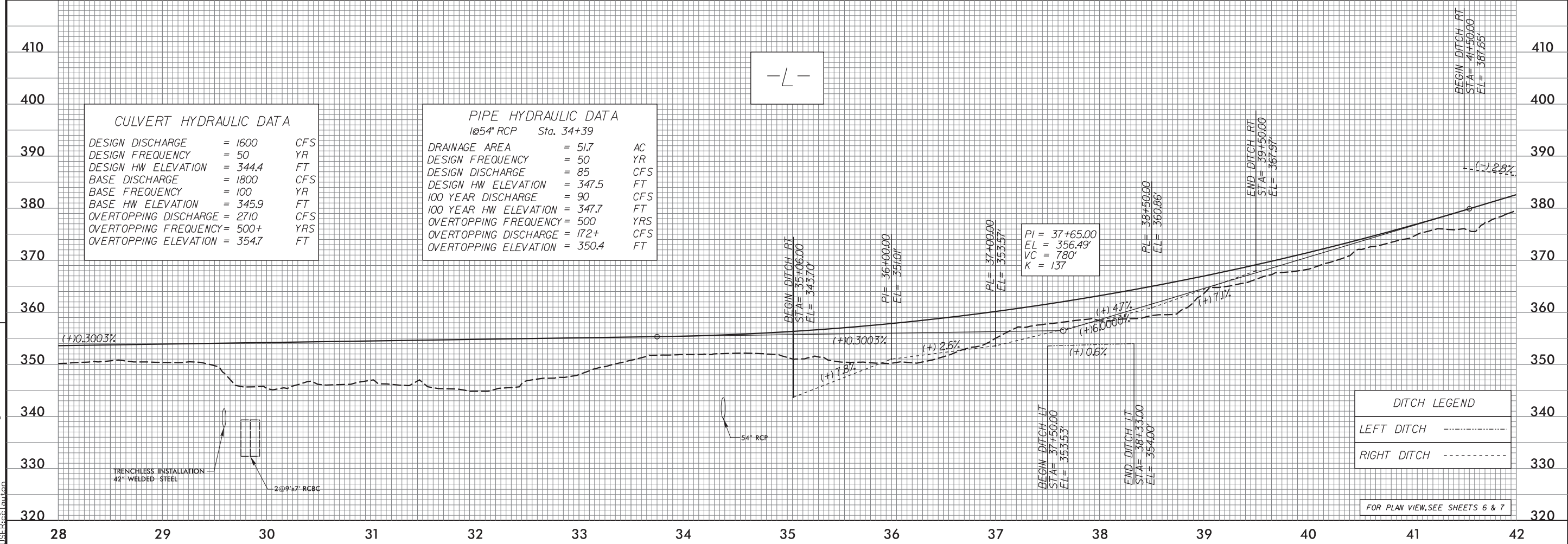

CULVERT HYDRAULIC DATA		
DESIGN DISCHARGE	= 1600	CFS
DESIGN FREQUENCY	= 50	YR
DESIGN HW ELEVATION	= 344.4	FT
BASE DISCHARGE	= 1800	CFS
BASE FREQUENCY	= 100	YR
BASE HW ELEVATION	= 345.9	FT
OVERTOPPING DISCHARGE	= 2710	CFS
OVERTOPPING FREQUENCY	= 500+	YRS
OVERTOPPING ELEVATION	= 354.7	FT

PIPE HYDRAULIC DATA		
1@54" RCP Sta. 34+39		
DRAINAGE AREA	= 51.7	AC
DESIGN FREQUENCY	= 50	YR
DESIGN DISCHARGE	= 85	CFS
DESIGN HW ELEVATION	= 347.5	FT
100 YEAR DISCHARGE	= 90	CFS
100 YEAR HW ELEVATION	= 347.7	FT
OVERTOPPING FREQUENCY	= 500	YRS
OVERTOPPING DISCHARGE	= 172+	CFS
OVERTOPPING ELEVATION	= 350.4	FT

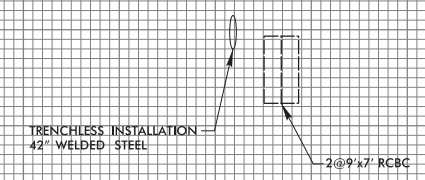



DITCH LEGEND	
LEFT DITCH	-----
RIGHT DITCH	-----

FOR PLAN VIEW, SEE SHEETS 6 & 7

2/24/2018 R2527_RDY_PFL42.dgn
15:55:00

5/14/99

PROJECT REFERENCE NO. <i>R-2527</i>	SHEET NO. <i>43</i>
ROADWAY DESIGN ENGINEER	HYDRAULICS ENGINEER
 STEWART	 vhb VHB Engineering NC, P.C. (C-3705) 940 Main Campus Drive, Suite 500 Raleigh, NC 27606
DOCUMENT NOT CONSIDERED FINAL UNLESS ALL SIGNATURES COMPLETED	

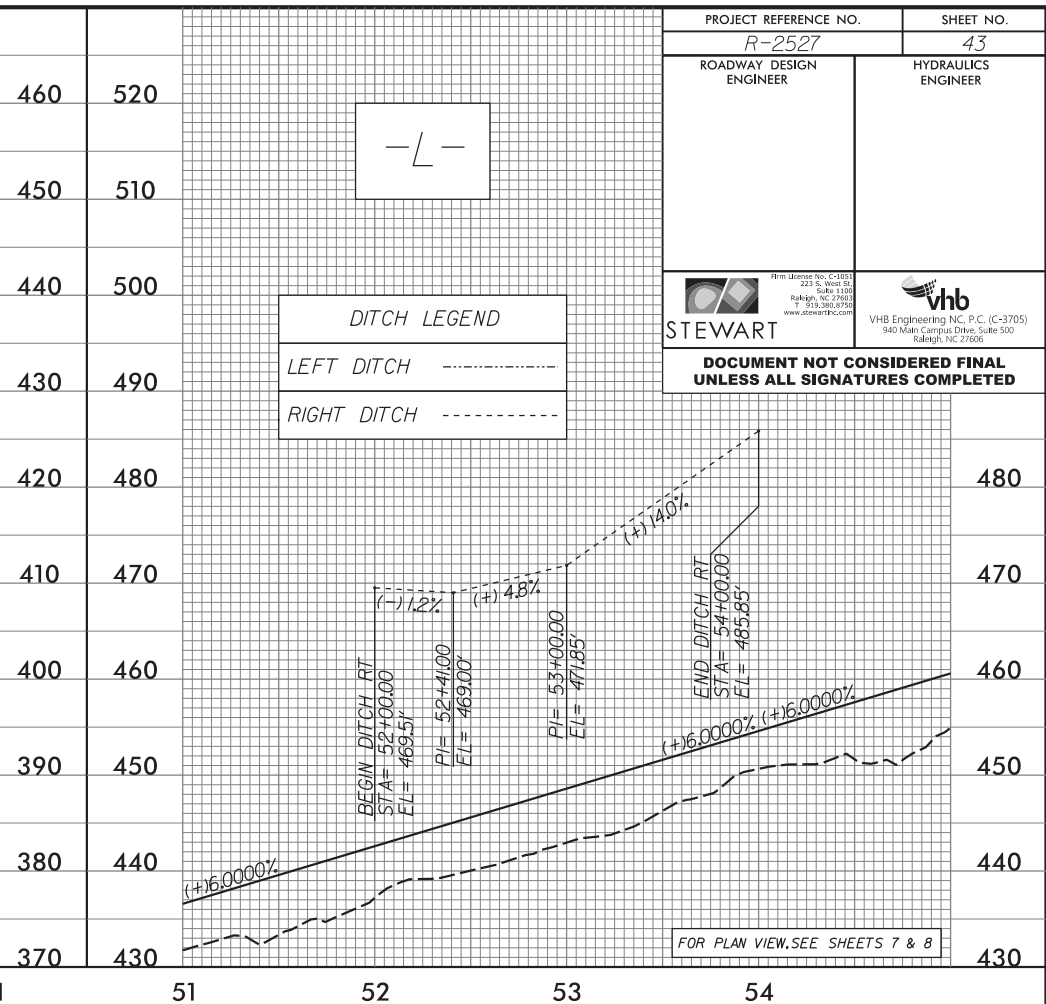
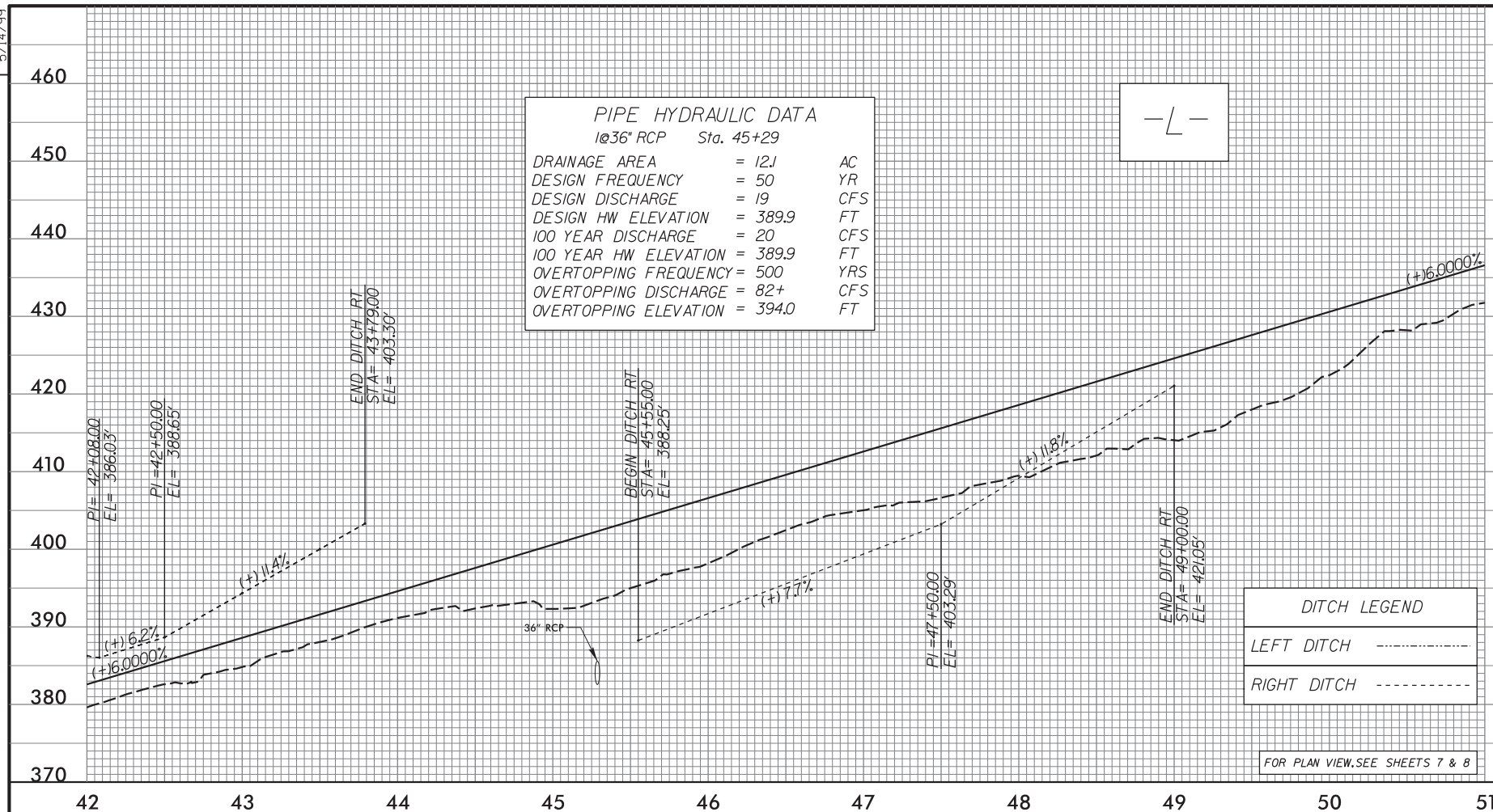

REVISIONS

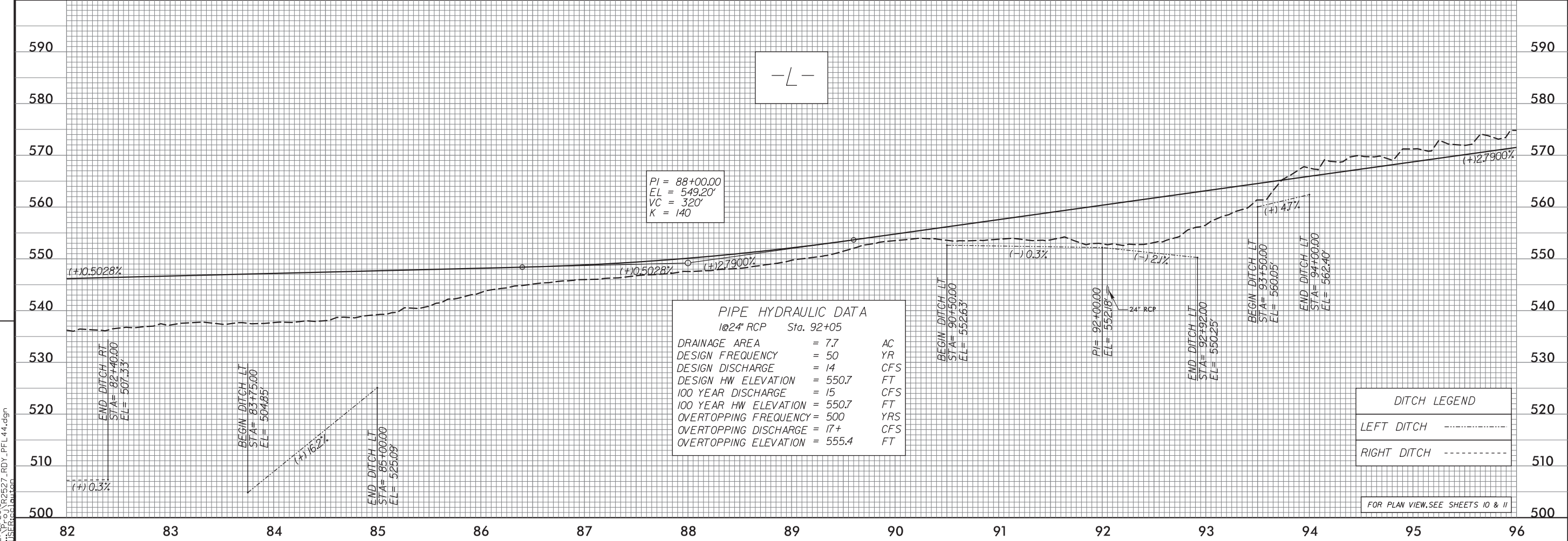
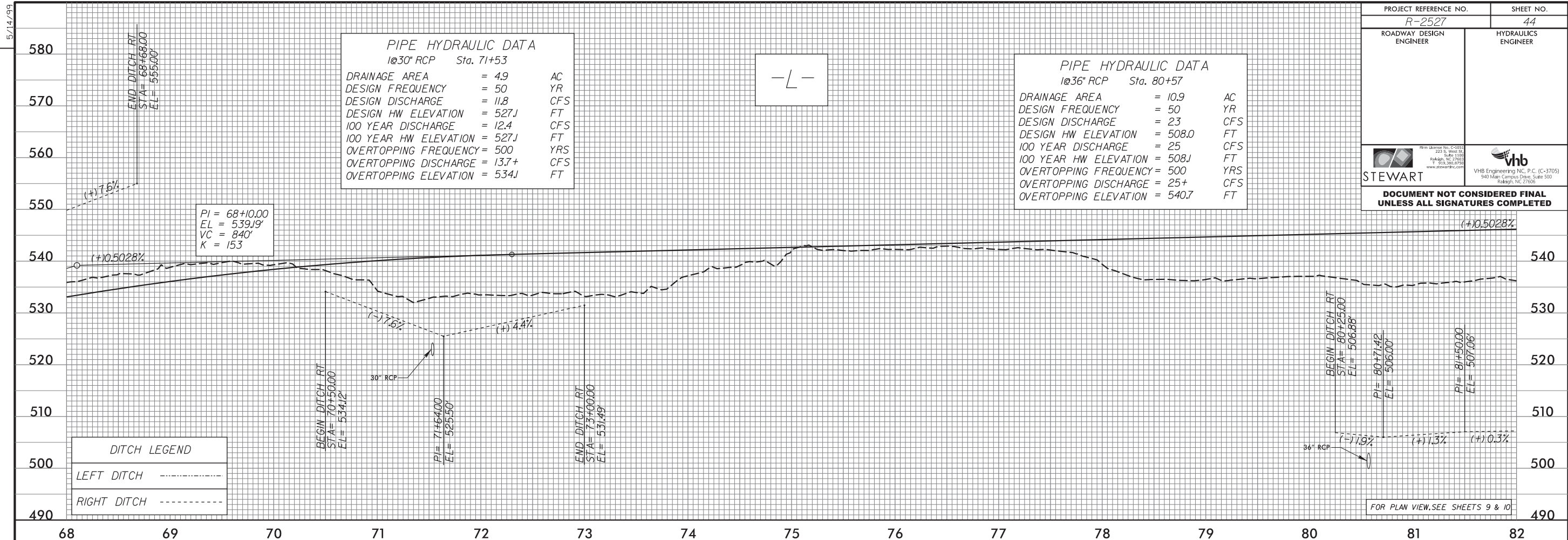

2/24/2018 R2527_RDY_PFL43.dgn
JES:rlc



REVISIONS

2/24/2018 R2527_RDY_PFL44.dgn
15:58:10

5/14/99

PROJECT REFERENCE NO. <i>R-2527</i>	SHEET NO. 45
ROADWAY DESIGN ENGINEER	HYDRAULICS ENGINEER
 STEWART	 VHB Engineering NC, P.C. (C-3705) 940 Main Campus Drive, Suite 500 Raleigh, NC 27606

DOCUMENT NOT CONSIDERED FINAL
UNLESS ALL SIGNATURES COMPLETED

PIPE HYDRAULIC DATA		
1@42" RCP Sta. 99+24		
DRAINAGE AREA	= 35.5	AC
DESIGN FREQUENCY	= 50	YR
DESIGN DISCHARGE	= 62	CFS
DESIGN HW ELEVATION	= 571.9	FT
100 YEAR DISCHARGE	= 65	CFS
100 YEAR HW ELEVATION	= 572.0	FT
OVERTOPPING FREQUENCY	= 500	YRS
OVERTOPPING DISCHARGE	= 72+	CFS
OVERTOPPING ELEVATION	= 575.8	FT

PI = 112+10.00
EL = 616.44'
VC = 650'
K = 152

REVISIONS

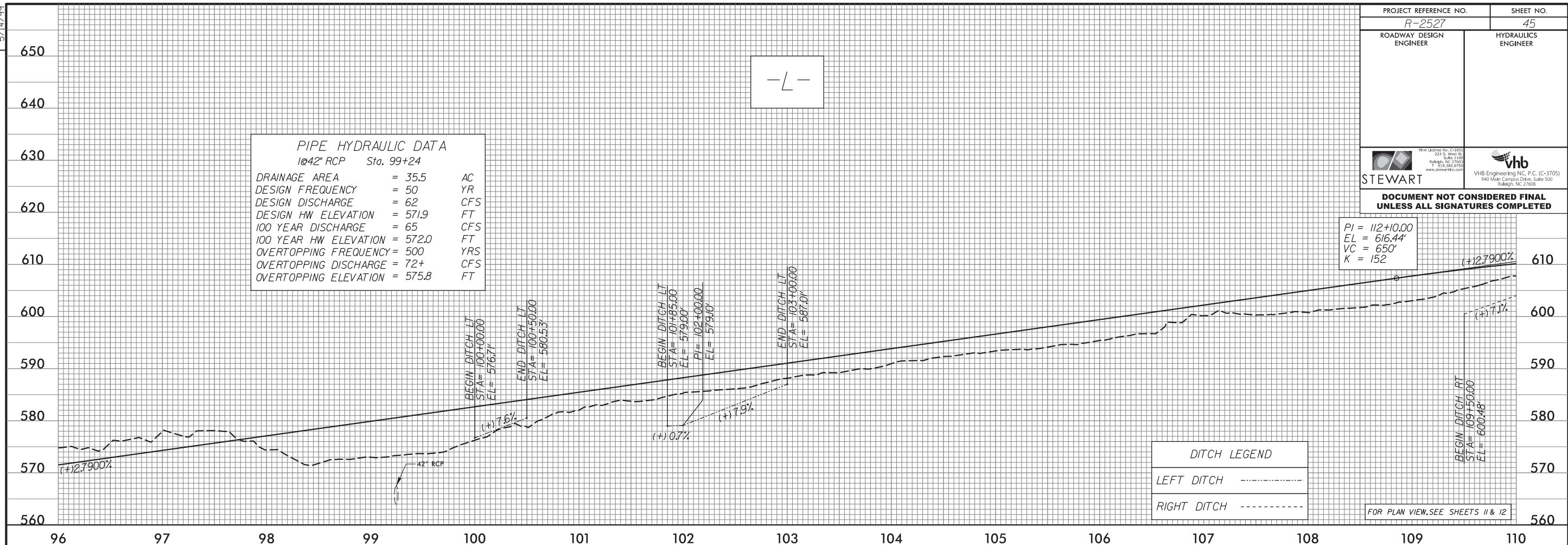

2/24/2018 R2527_RDY_PFL45.dgn

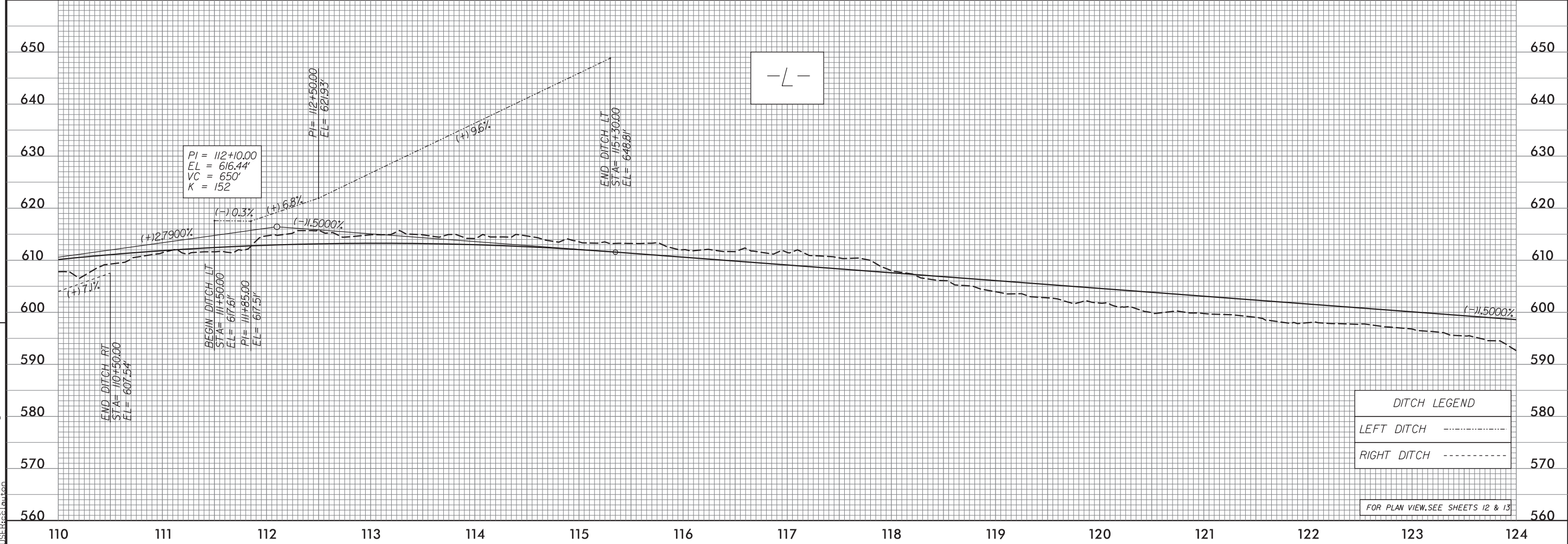

DITCH LEGEND	
LEFT DITCH	-----
RIGHT DITCH

FOR PLAN VIEW, SEE SHEETS 11 & 12

FOR PLAN VIEW, SEE SHEETS 12 & 13

PIPE HYDRAULIC DATA		
1@48" RCP Sta. 125+48		
DRAINAGE AREA	= 36	AC
DESIGN FREQUENCY	= 50	YR
DESIGN DISCHARGE	= 60	CFS
DESIGN HW ELEVATION	= 566.4	FT
100 YEAR DISCHARGE	= 65	CFS
100 YEAR HW ELEVATION	= 566.6	FT
OVERTOPPING FREQUENCY	= 500	YRS
OVERTOPPING DISCHARGE	= 167	CFS
OVERTOPPING ELEVATION	= 576.0	FT

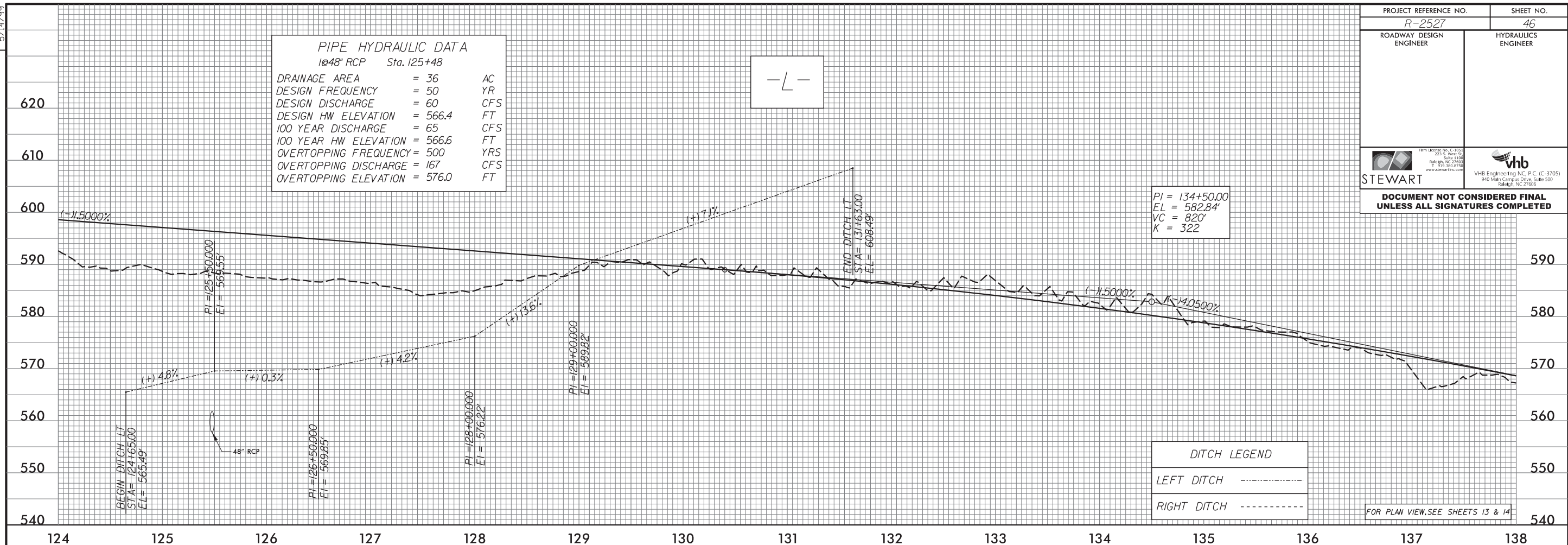

PIPE HYDRAULIC DATA		
1@42" RCP Sta. 141+91		
DRAINAGE AREA	= 24.5	AC
DESIGN FREQUENCY	= 50	YR
DESIGN DISCHARGE	= 43	CFS
DESIGN HW ELEVATION	= 543.5	FT
100 YEAR DISCHARGE	= 46	CFS
100 YEAR HW ELEVATION	= 543.6	FT
OVERTOPPING FREQUENCY	= 500	YRS
OVERTOPPING DISCHARGE	= 60	CFS
OVERTOPPING ELEVATION	= 544.2	FT

PIPE HYDRAULIC DATA		
1@42" RCP Sta. 150+39		
DRAINAGE AREA	= 20.5	AC
DESIGN FREQUENCY	= 50	YR
DESIGN DISCHARGE	= 39	CFS
DESIGN HW ELEVATION	= 494.6	FT
100 YEAR DISCHARGE	= 41	CFS
100 YEAR HW ELEVATION	= 494.7	FT
OVERTOPPING FREQUENCY	= 500	YRS
OVERTOPPING DISCHARGE	= 45+	CFS
OVERTOPPING ELEVATION	= 507.3	FT

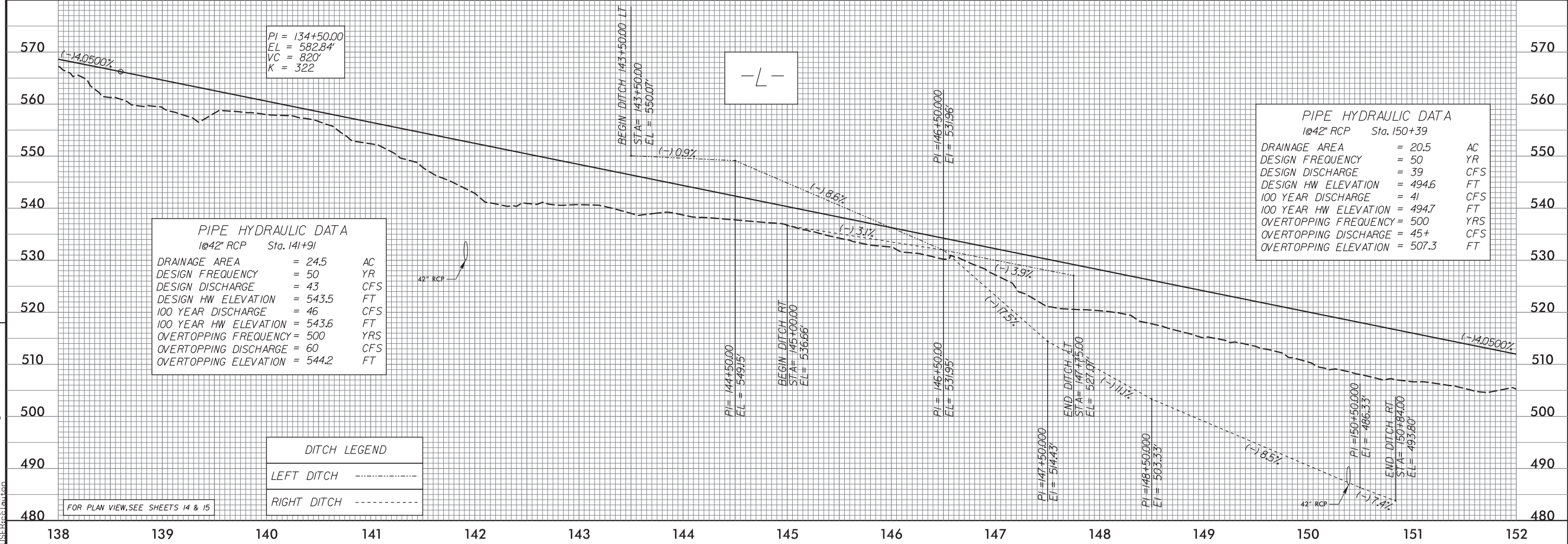

REVISIONS

2/24/2018 R2527_RDY_PFL46.dgn
JES:RCL

5/14/99

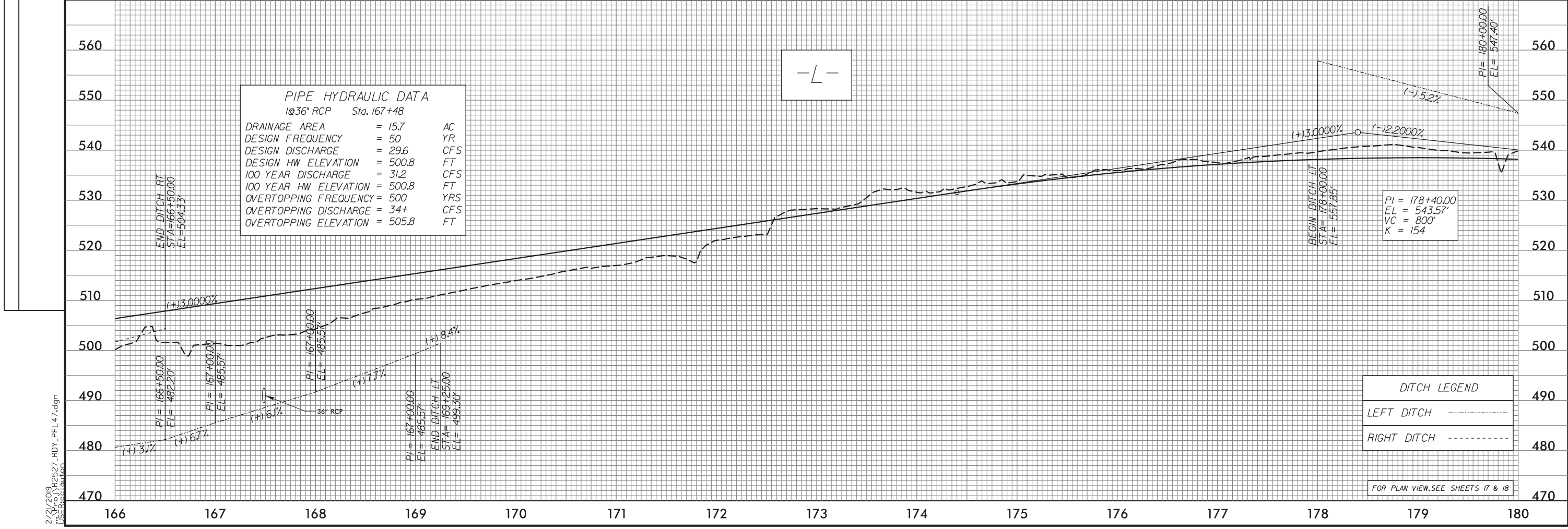
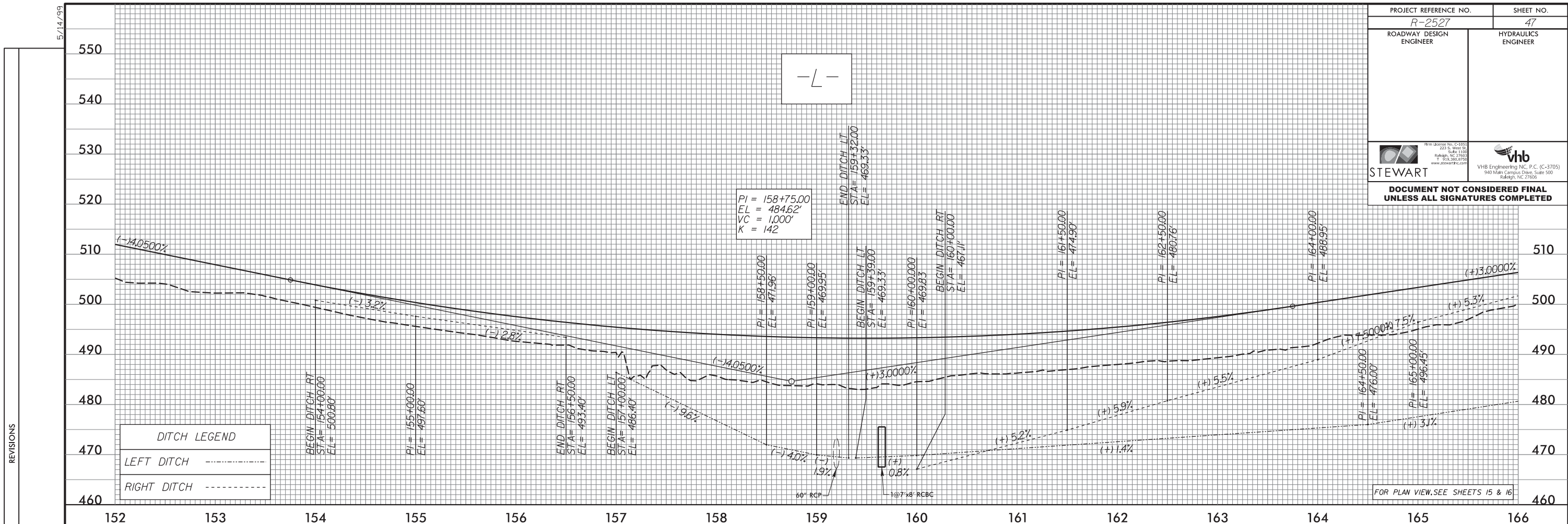

REVISIONS

5/14/99
2/24/2018 R2527_RDY_PFL47.dgn
15:55:10
15:55:10

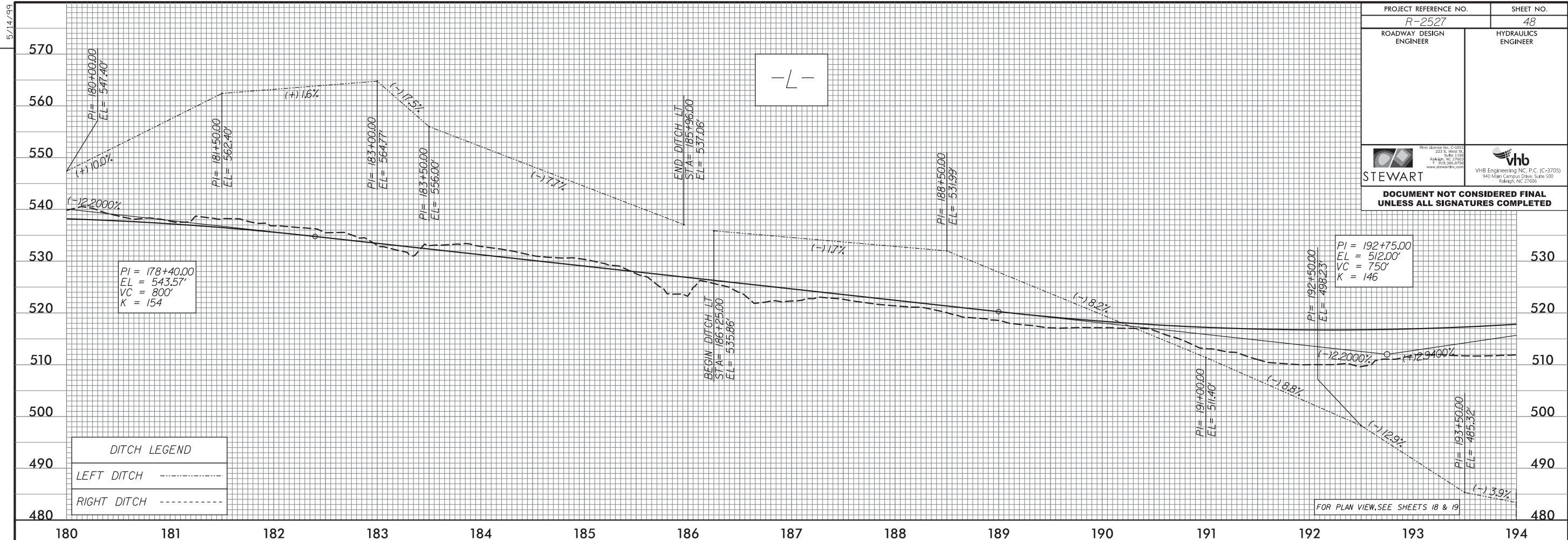

DITCH LEGEND

LEFT DITCH	-----
RIGHT DITCH	-----

FOR PLAN VIEW, SEE SHEETS 18 & 19

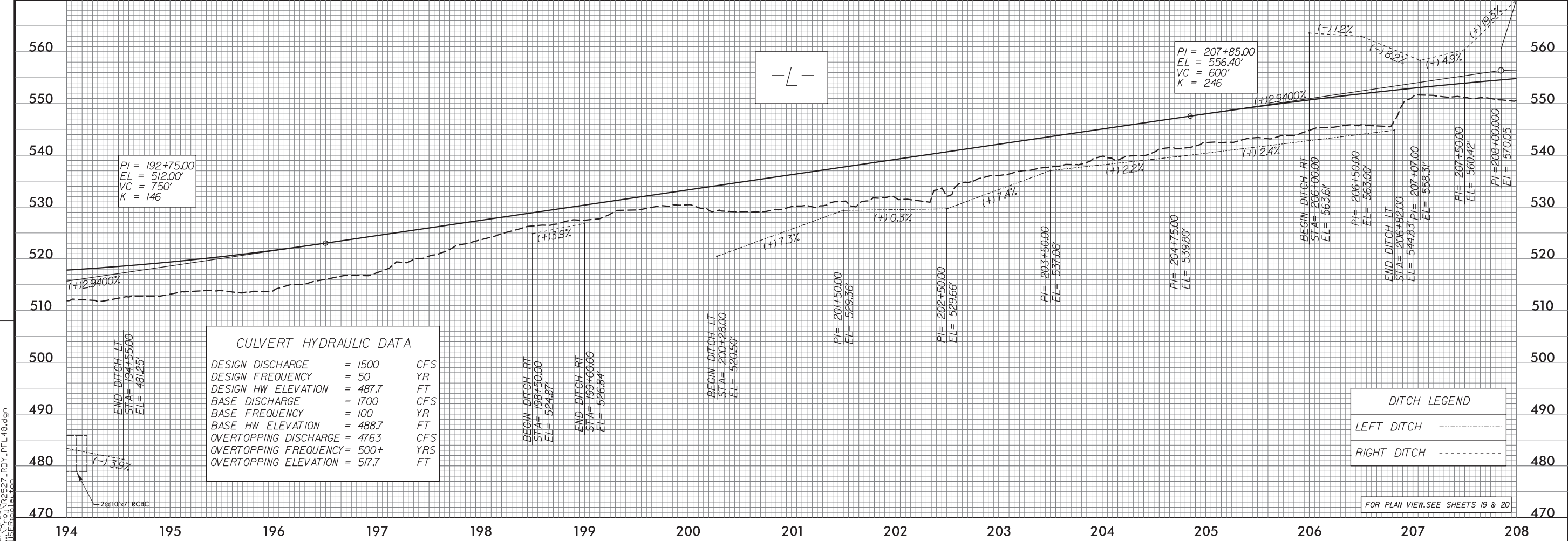

CULVERT HYDRAULIC DATA

DESIGN DISCHARGE	= 1500	CFS
DESIGN FREQUENCY	= 50	YR
DESIGN HW ELEVATION	= 487.7	FT
BASE DISCHARGE	= 1700	CFS
BASE FREQUENCY	= 100	YR
BASE HW ELEVATION	= 488.7	FT
OVERTOPPING DISCHARGE	= 4763	CFS
OVERTOPPING FREQUENCY	= 500+	YRS
OVERTOPPING ELEVATION	= 517.7	FT

DITCH LEGEND

LEFT DITCH	-----
RIGHT DITCH	-----

FOR PLAN VIEW, SEE SHEETS 19 & 20

REVISIONS

2/24/2018 R2527_RDY_PFL48.dgn
15:58:00

5/14/99

5/14/99

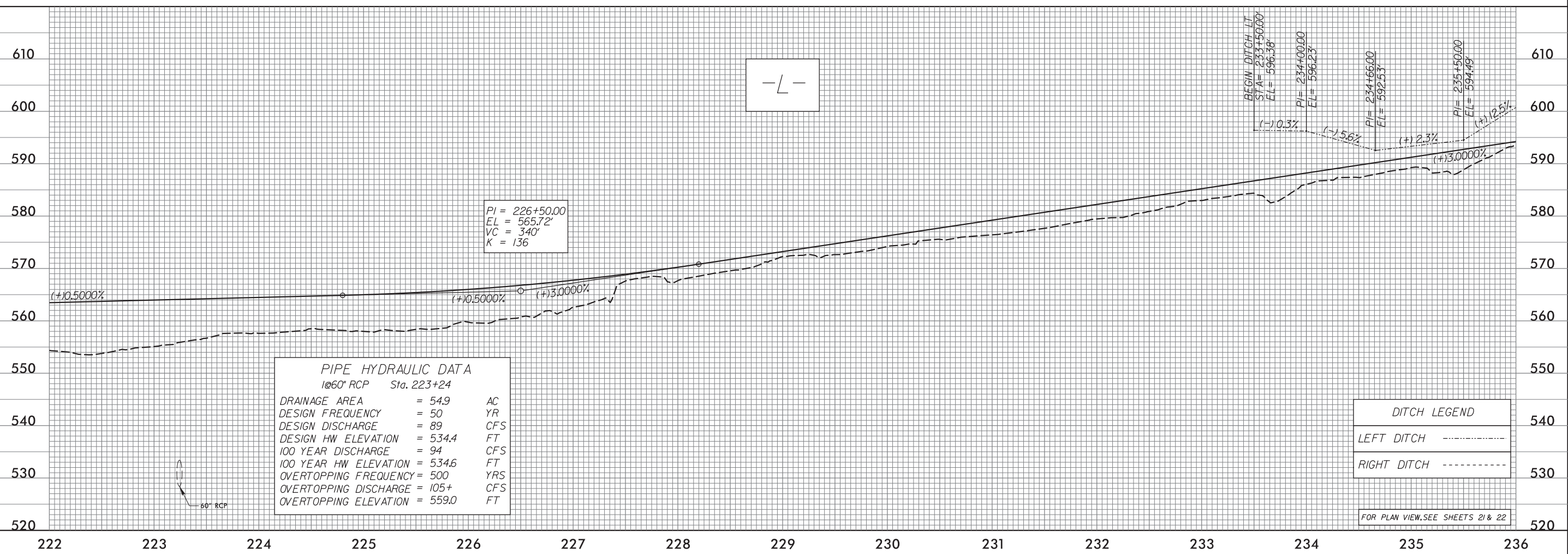
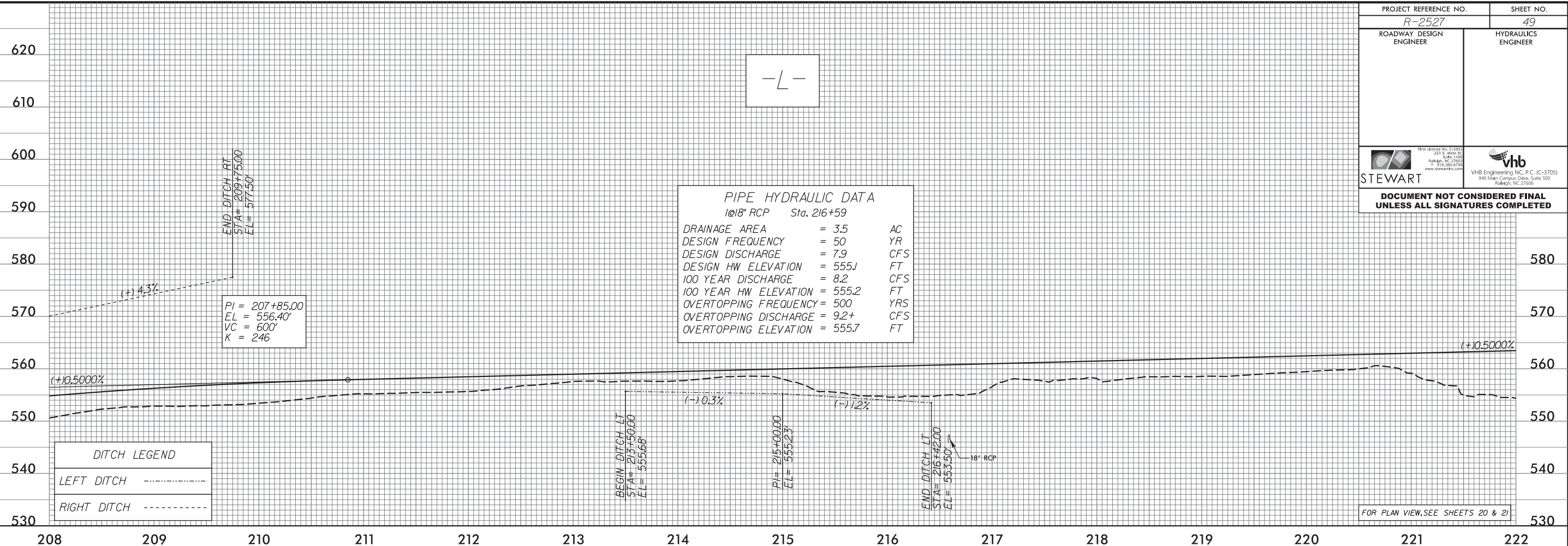

REVISIONS

2/21/2018 R-2527_RDY_PFL49.dgn
JES/ELC/10/10/18

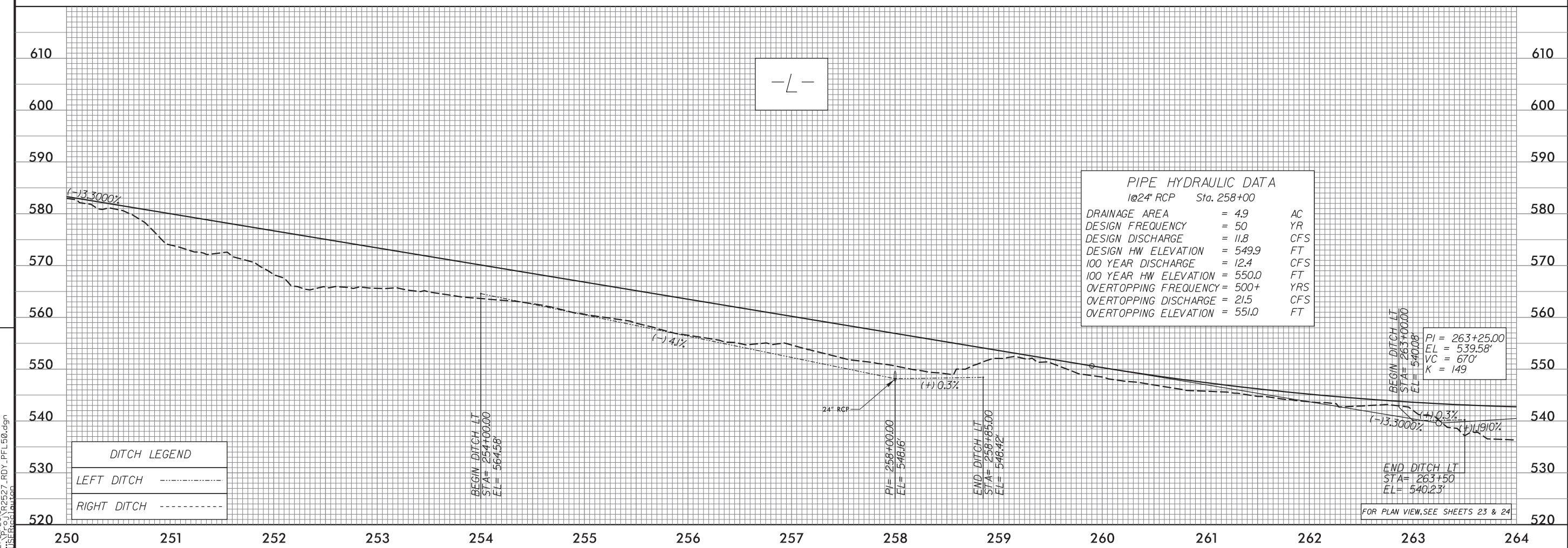
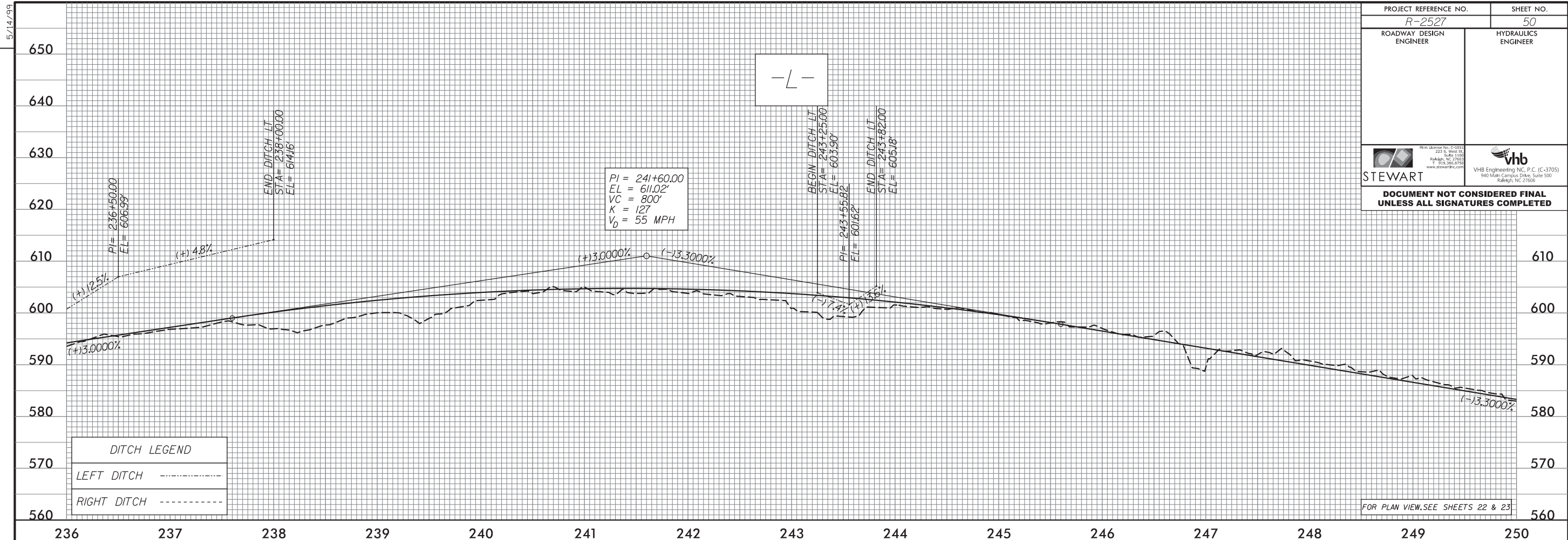



PIPE HYDRAULIC DATA		
1@24" RCP Sta. 258+00		
DRAINAGE AREA	= 4.9	AC
DESIGN FREQUENCY	= 50	YR
DESIGN DISCHARGE	= 11.8	CFS
DESIGN HW ELEVATION	= 549.9	FT
100 YEAR DISCHARGE	= 12.4	CFS
100 YEAR HW ELEVATION	= 550.0	FT
OVERTOPPING FREQUENCY	= 500+	YRS
OVERTOPPING DISCHARGE	= 21.5	CFS
OVERTOPPING ELEVATION	= 551.0	FT

REVISIONS

2/2/2018 R2527_RDY_PFL50.dgn
15:58:10

5/14/99

5/14/99

PROJECT REFERENCE NO. R-2527	SHEET NO. 51
ROADWAY DESIGN ENGINEER	HYDRAULICS ENGINEER
 STEWART	 vhb VHB Engineering NC, P.C. (C-3705) 940 Main Campus Drive, Suite 500 Raleigh, NC 27606
DOCUMENT NOT CONSIDERED FINAL UNLESS ALL SIGNATURES COMPLETED	

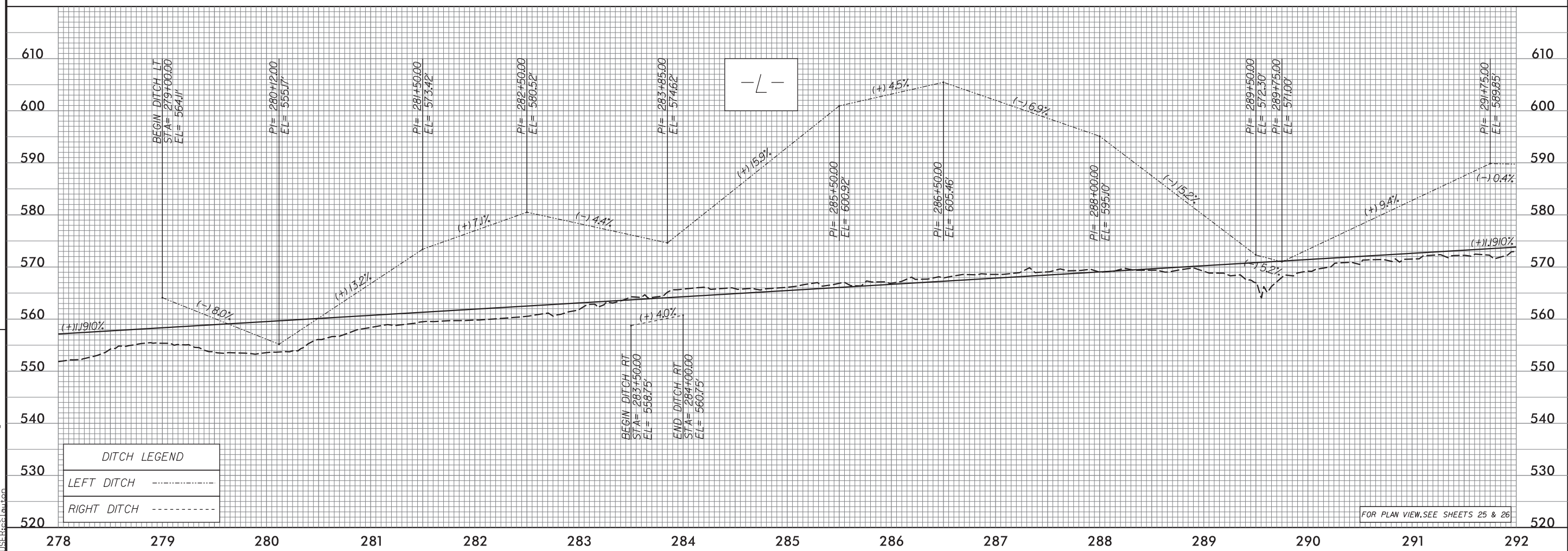
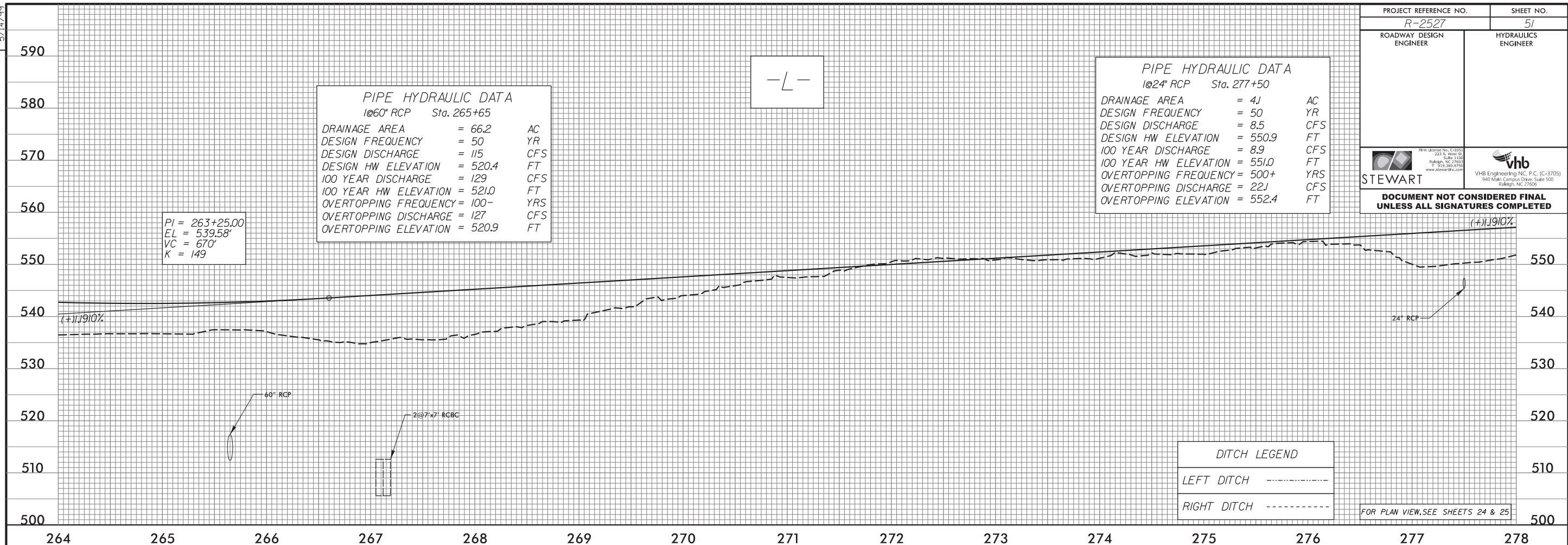

REVISIONS

2/24/2019 R2527_RDY_PFL51.dgn
JES/rlc/ton

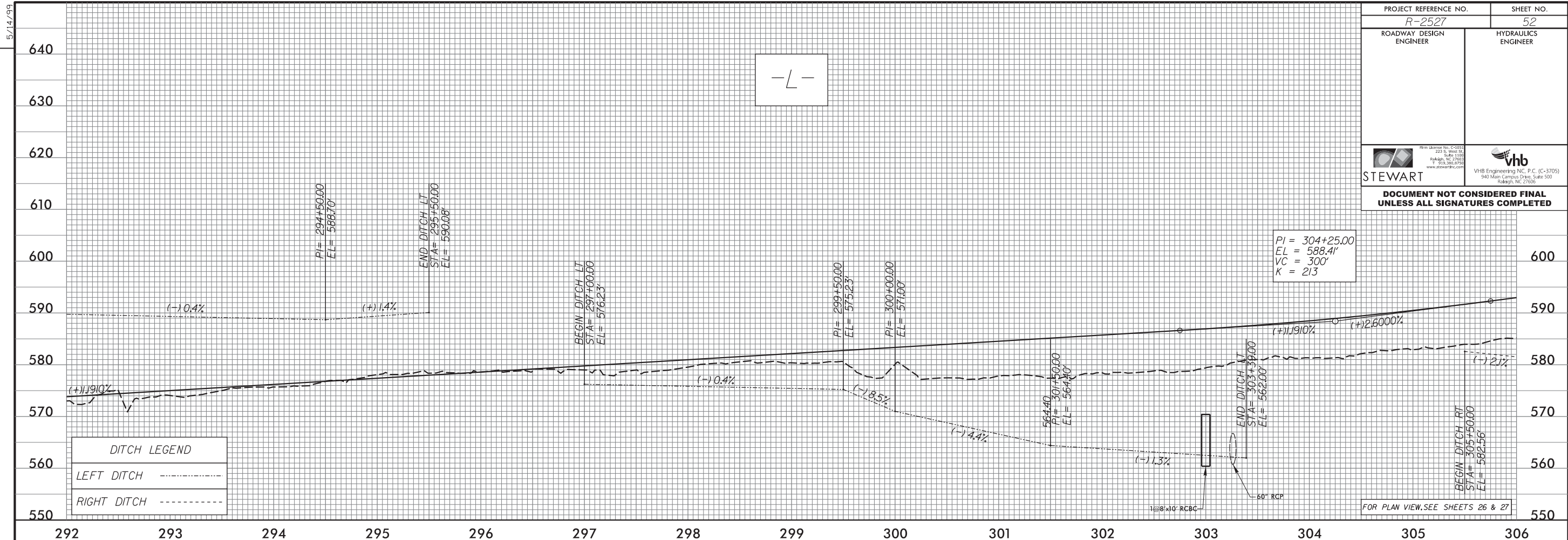

DITCH LEGEND

LEFT DITCH	-----
RIGHT DITCH	-----

FOR PLAN VIEW, SEE SHEETS 26 & 27

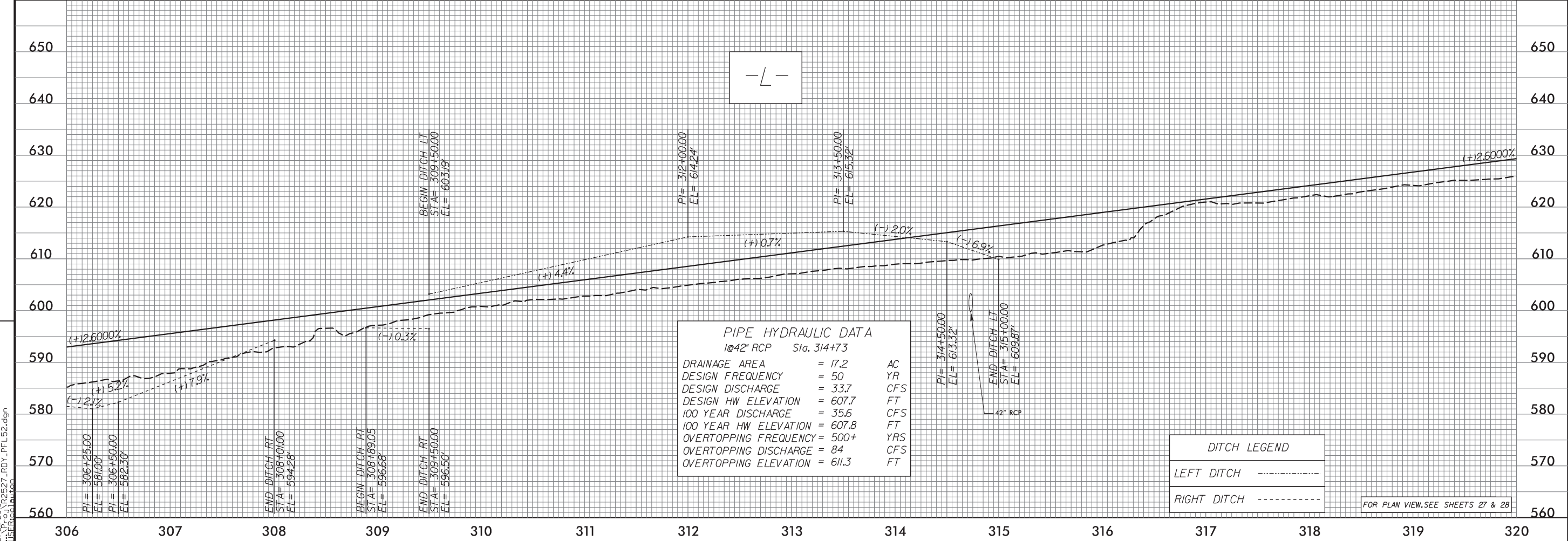

PIPE HYDRAULIC DATA
1@42" RCP Sta. 314+73

DRAINAGE AREA	= 17.2	AC
DESIGN FREQUENCY	= 50	YR
DESIGN DISCHARGE	= 33.7	CFS
DESIGN HW ELEVATION	= 607.7	FT
100 YEAR DISCHARGE	= 35.6	CFS
100 YEAR HW ELEVATION	= 607.8	FT
OVERTOPPING FREQUENCY	= 500+	YRS
OVERTOPPING DISCHARGE	= 84	CFS
OVERTOPPING ELEVATION	= 611.3	FT

DITCH LEGEND

LEFT DITCH	-----
RIGHT DITCH	-----

FOR PLAN VIEW, SEE SHEETS 27 & 28

REVISIONS

2/24/2018 R2527_RDY_PFL52.dgn
JSE/ric/auton

5/14/99

5/14/99

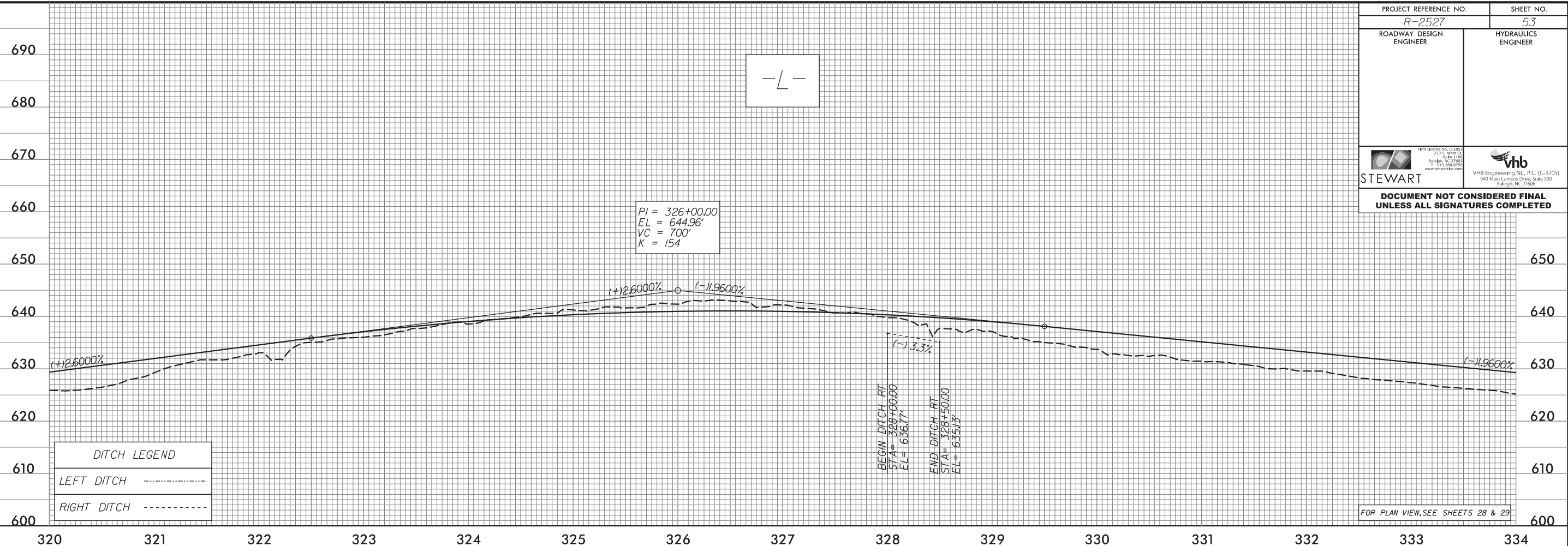

REVISIONS

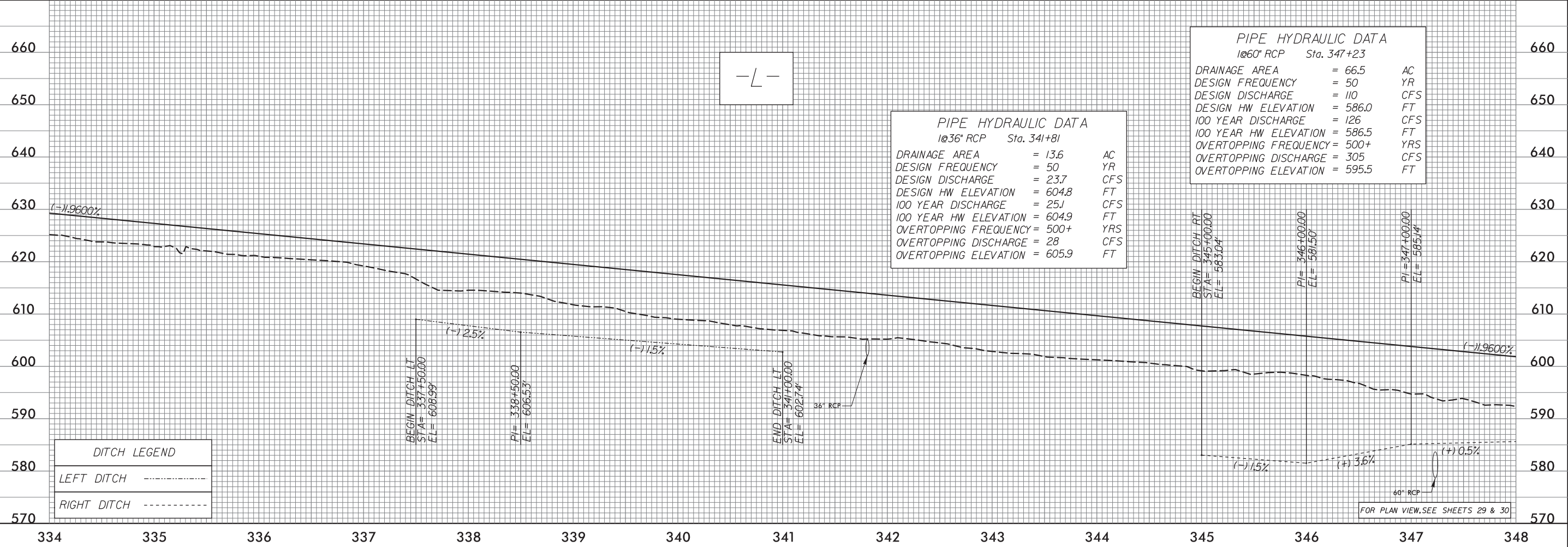

2/21/2018 R2527_RDY_PFL53.dgn
JSE/ELC/auton

PIPE HYDRAULIC DATA
1@30" RCP Sta. 352+31

DRAINAGE AREA	= 12.6	AC
DESIGN FREQUENCY	= 50	YR
DESIGN DISCHARGE	= 26.9	CFS
DESIGN HW ELEVATION	= 586.6	FT
100 YEAR DISCHARGE	= 28.4	CFS
100 YEAR HW ELEVATION	= 586.7	FT
OVERTOPPING FREQUENCY	= 500+	YRS
OVERTOPPING DISCHARGE	= 49	CFS
OVERTOPPING ELEVATION	= 588.7	FT

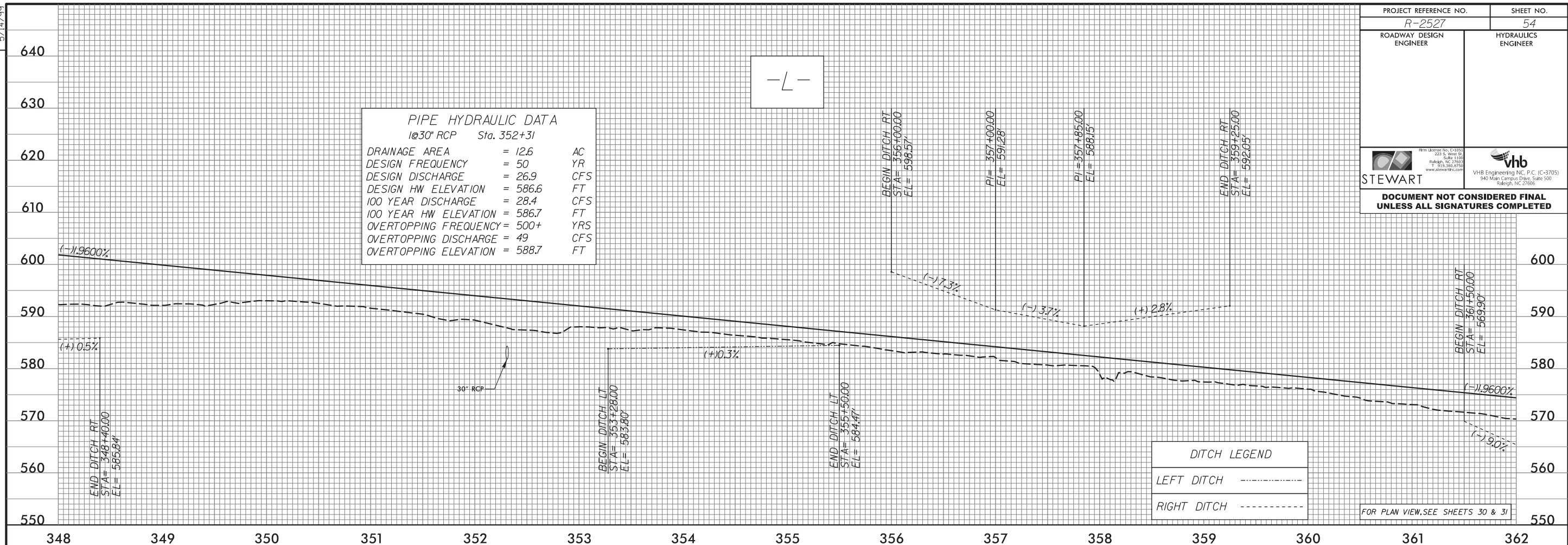

DITCH LEGEND

LEFT DITCH	-----
RIGHT DITCH	-----

FOR PLAN VIEW, SEE SHEETS 30 & 31

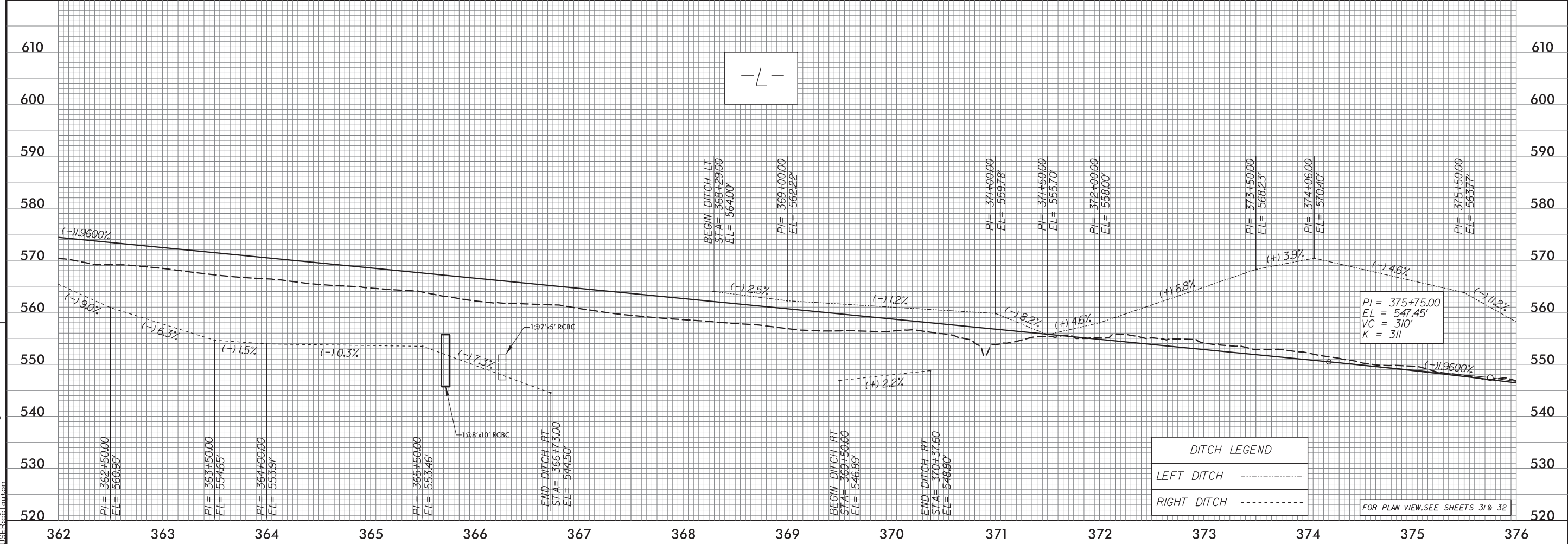

DITCH LEGEND

LEFT DITCH	-----
RIGHT DITCH	-----

FOR PLAN VIEW, SEE SHEETS 31 & 32

REVISIONS

2/21/2018 R2527_RDY_PFL54.dgn
JIS:R10/10/10

5/14/99

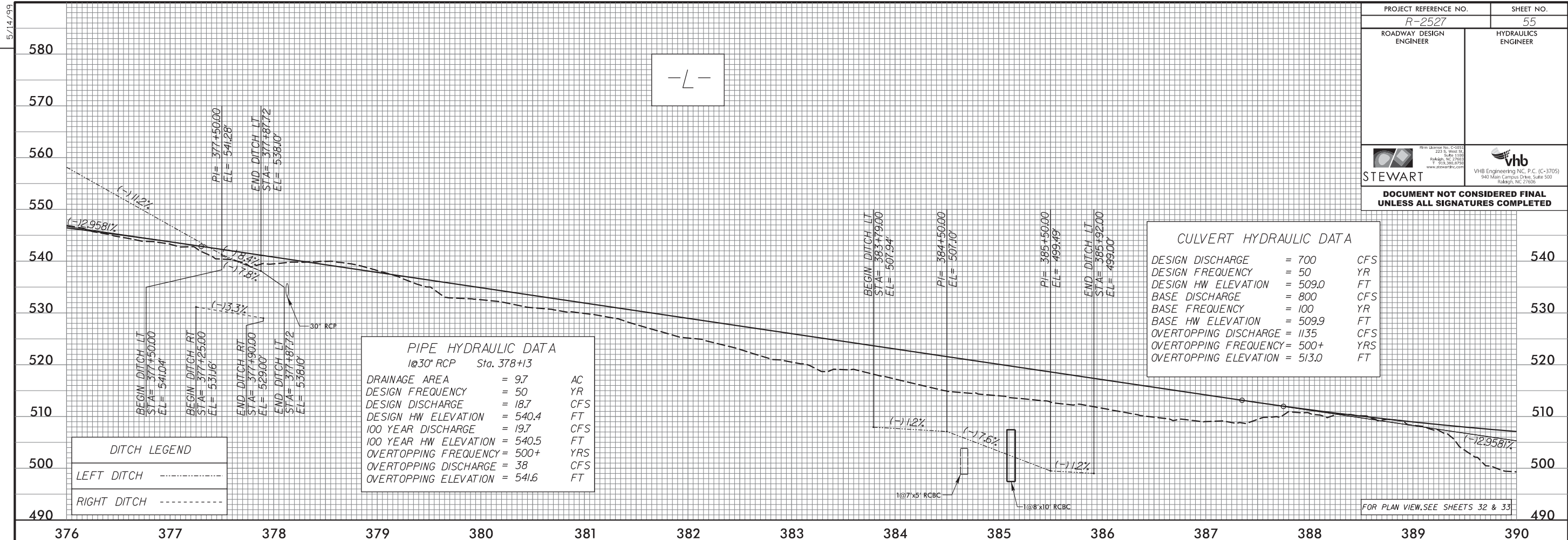

CULVERT HYDRAULIC DATA		
DESIGN DISCHARGE	= 700	CFS
DESIGN FREQUENCY	= 50	YR
DESIGN HW ELEVATION	= 509.0	FT
BASE DISCHARGE	= 800	CFS
BASE FREQUENCY	= 100	YR
BASE HW ELEVATION	= 509.9	FT
OVERTOPPING DISCHARGE	= 1135	CFS
OVERTOPPING FREQUENCY	= 500+	YRS
OVERTOPPING ELEVATION	= 513.0	FT

PIPE HYDRAULIC DATA		
1@30' RCP Sta. 378+13		
DRAINAGE AREA	= 9.7	AC
DESIGN FREQUENCY	= 50	YR
DESIGN DISCHARGE	= 18.7	CFS
DESIGN HW ELEVATION	= 540.4	FT
100 YEAR DISCHARGE	= 19.7	CFS
100 YEAR HW ELEVATION	= 540.5	FT
OVERTOPPING FREQUENCY	= 500+	YRS
OVERTOPPING DISCHARGE	= 38	CFS
OVERTOPPING ELEVATION	= 541.6	FT

DITCH LEGEND	
LEFT DITCH	-----
RIGHT DITCH	-----

REVISIONS

2/24/2018 R2527_RDY_PFL55.dgn
JES:rlc

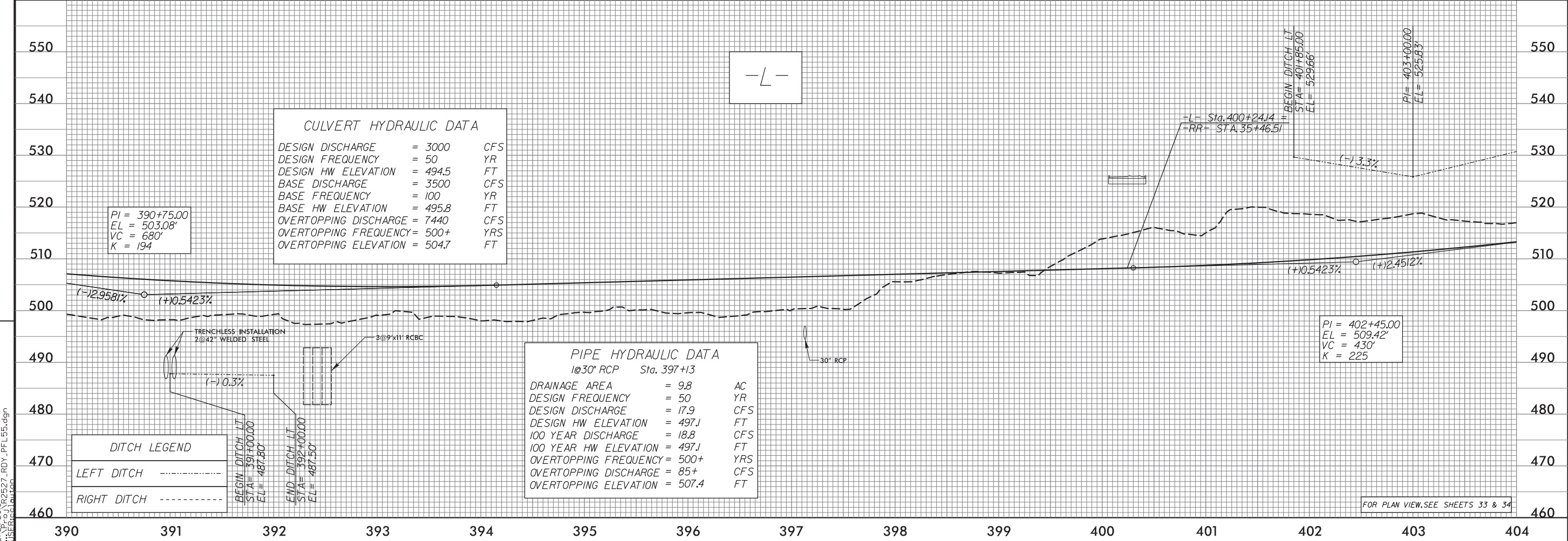

CULVERT HYDRAULIC DATA		
DESIGN DISCHARGE	= 3000	CFS
DESIGN FREQUENCY	= 50	YR
DESIGN HW ELEVATION	= 494.5	FT
BASE DISCHARGE	= 3500	CFS
BASE FREQUENCY	= 100	YR
BASE HW ELEVATION	= 495.8	FT
OVERTOPPING DISCHARGE	= 7440	CFS
OVERTOPPING FREQUENCY	= 500+	YRS
OVERTOPPING ELEVATION	= 504.7	FT

PIPE HYDRAULIC DATA		
1@30' RCP Sta. 397+13		
DRAINAGE AREA	= 9.8	AC
DESIGN FREQUENCY	= 50	YR
DESIGN DISCHARGE	= 17.9	CFS
DESIGN HW ELEVATION	= 497.1	FT
100 YEAR DISCHARGE	= 18.8	CFS
100 YEAR HW ELEVATION	= 497.1	FT
OVERTOPPING FREQUENCY	= 500+	YRS
OVERTOPPING DISCHARGE	= 85+	CFS
OVERTOPPING ELEVATION	= 507.4	FT

DITCH LEGEND	
LEFT DITCH	-----
RIGHT DITCH	-----

PI = 390+75.00 EL = 503.08' VC = 680' K = 194
--

PI = 402+45.00 EL = 509.42' VC = 430' K = 225
--

FOR PLAN VIEW, SEE SHEETS 33 & 34

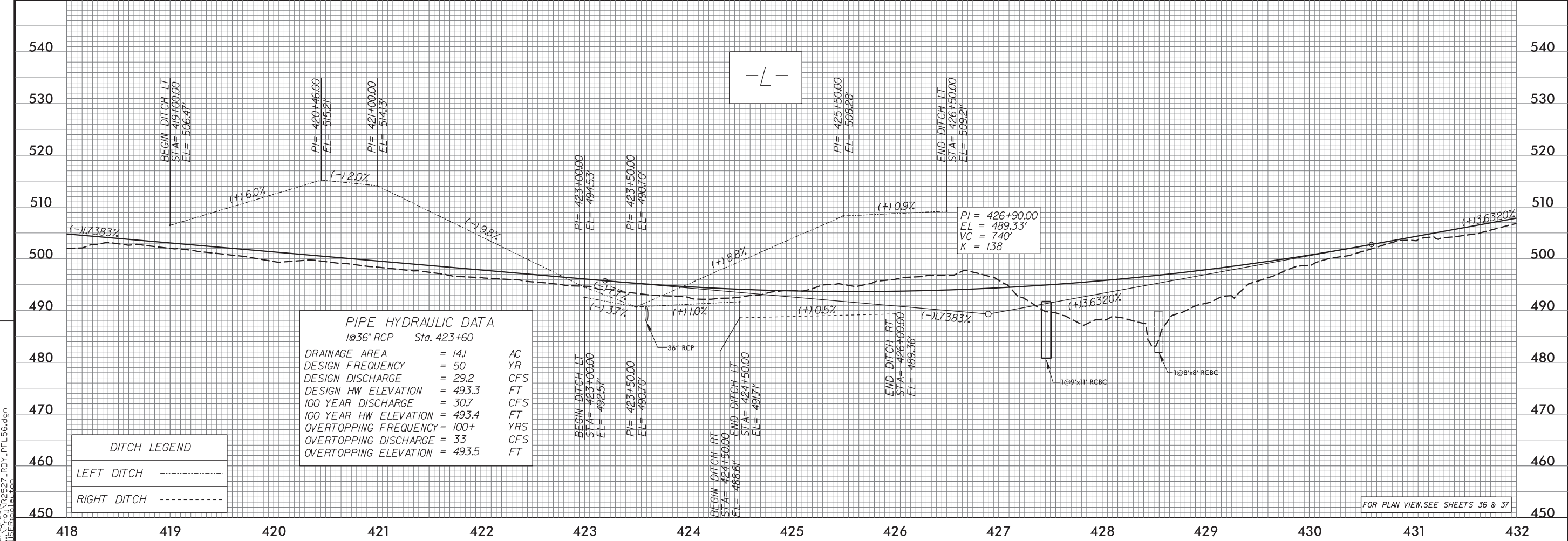
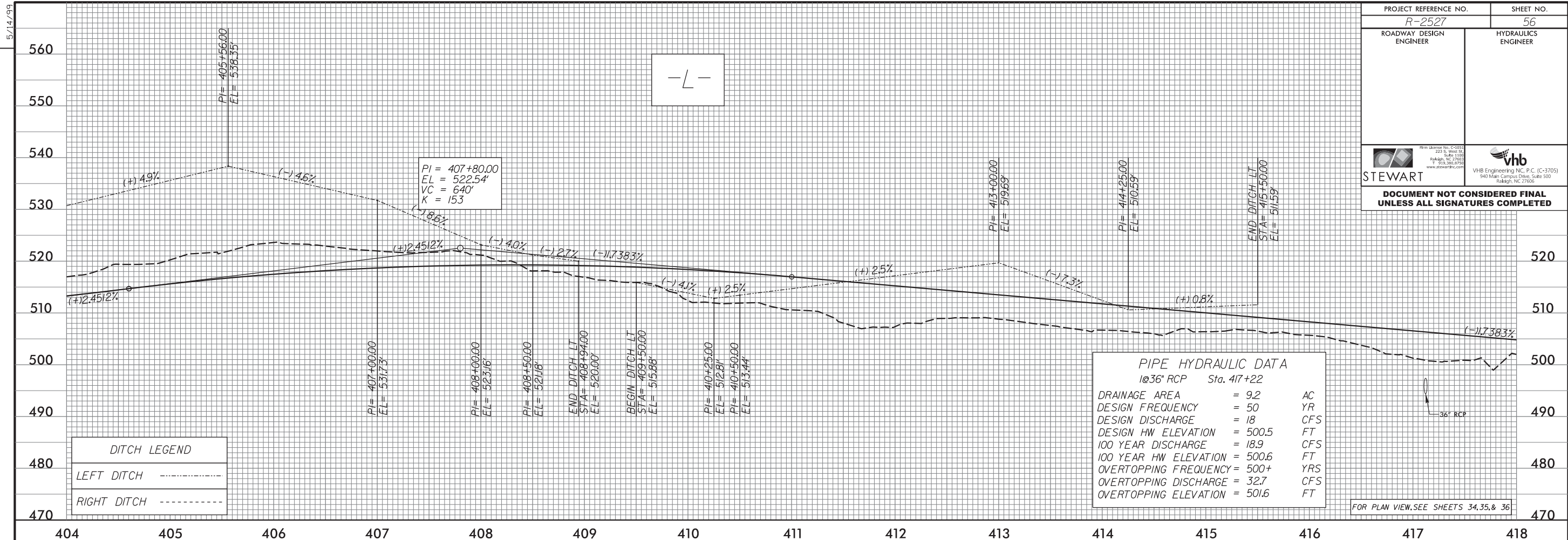

REVISIONS

2/21/2018 R-2527_RDY_PFL56.dgn
JES:RCL

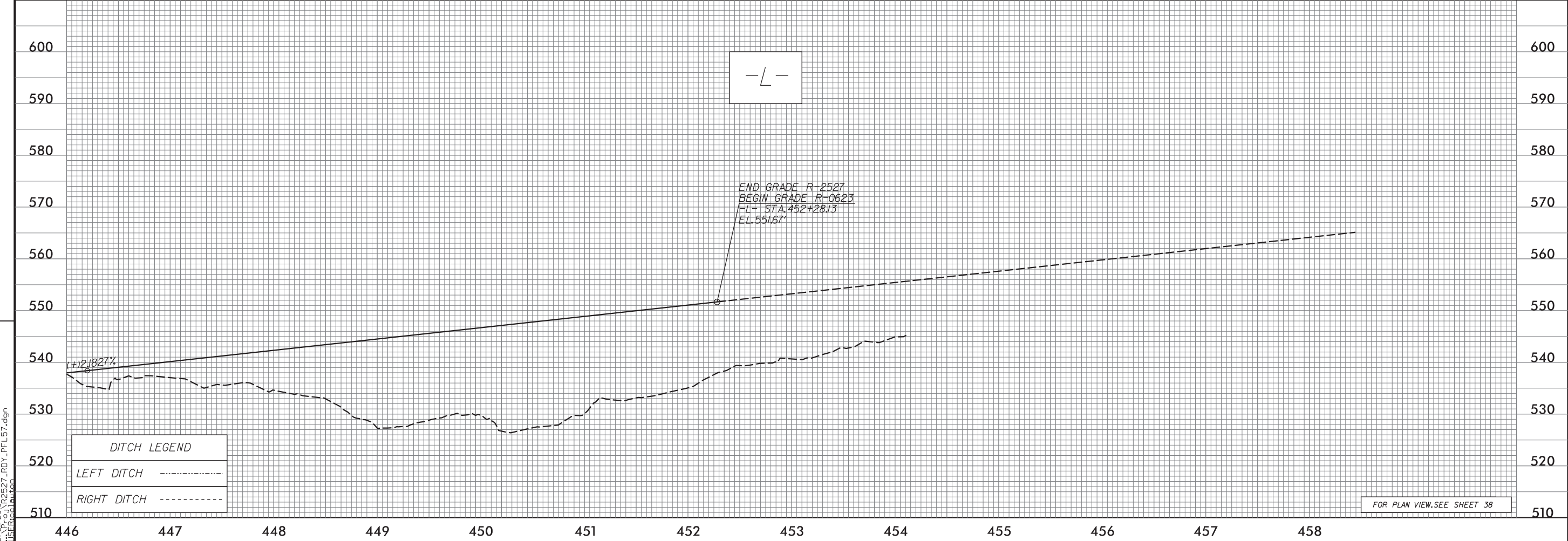
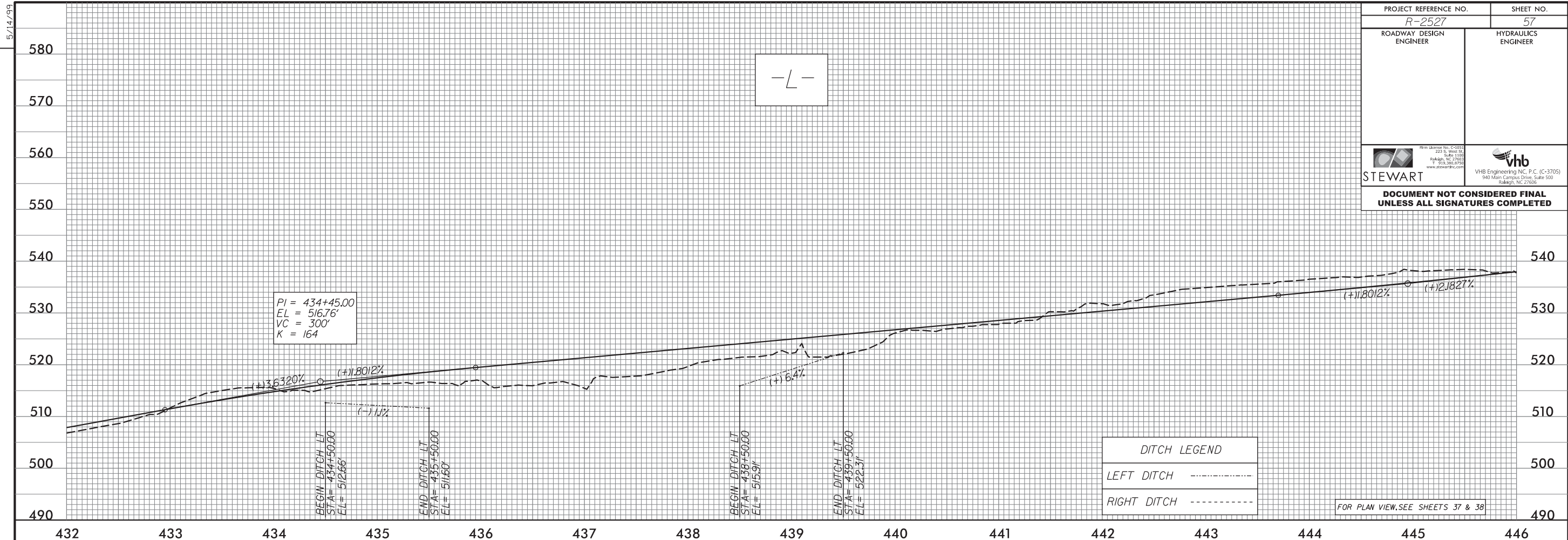

2/24/2016 R2527_RDY_PFL57.dgn
JSE/10/10/10

5/14/99

REVISIONS

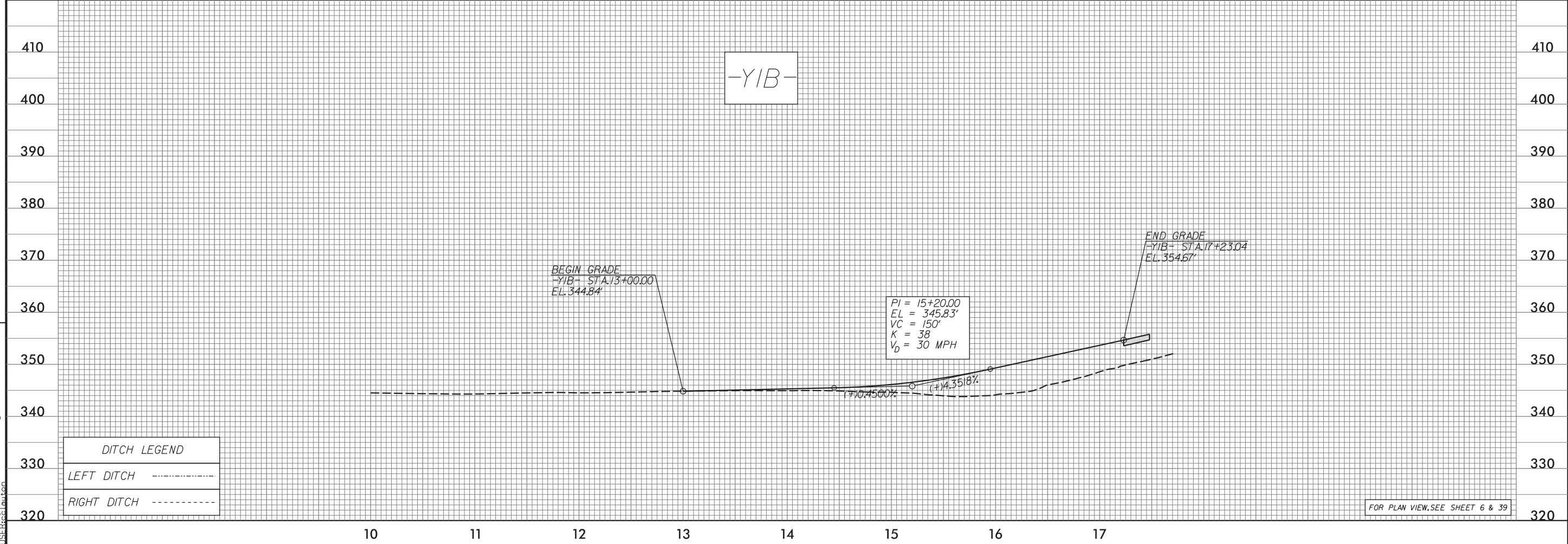
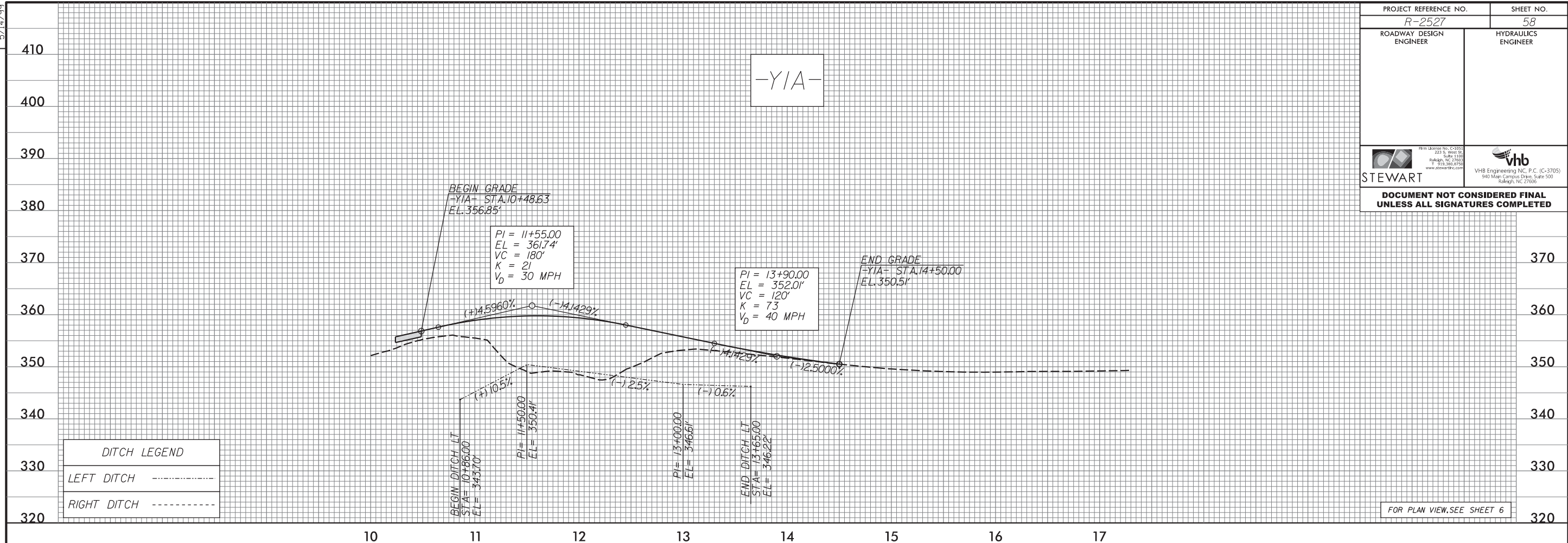

2/24/2018 R2527_RDY_PFL58.dgn
 JES:rlc

5/14/99

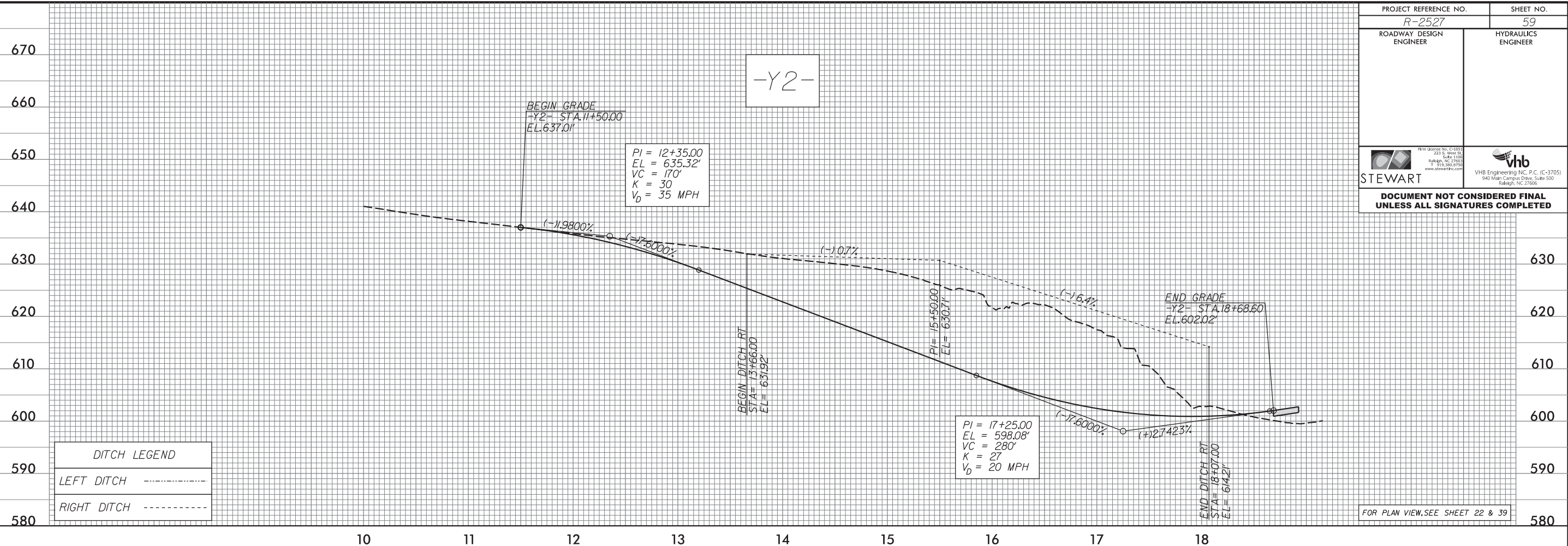

REVISIONS

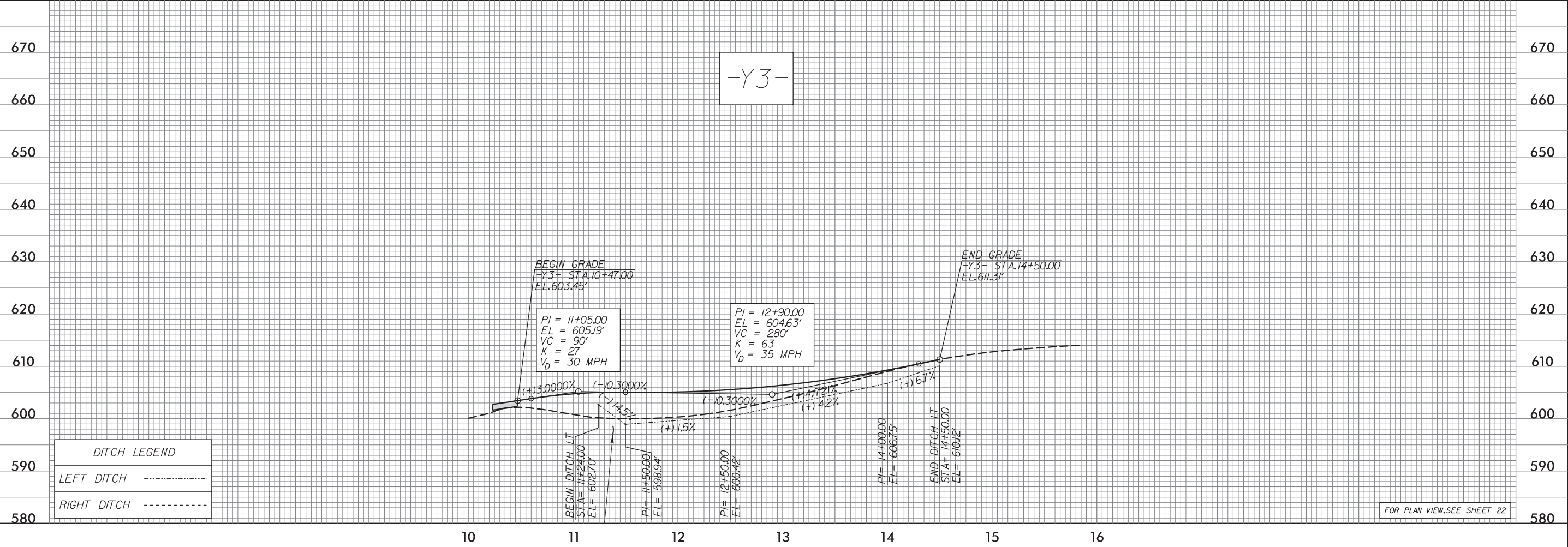

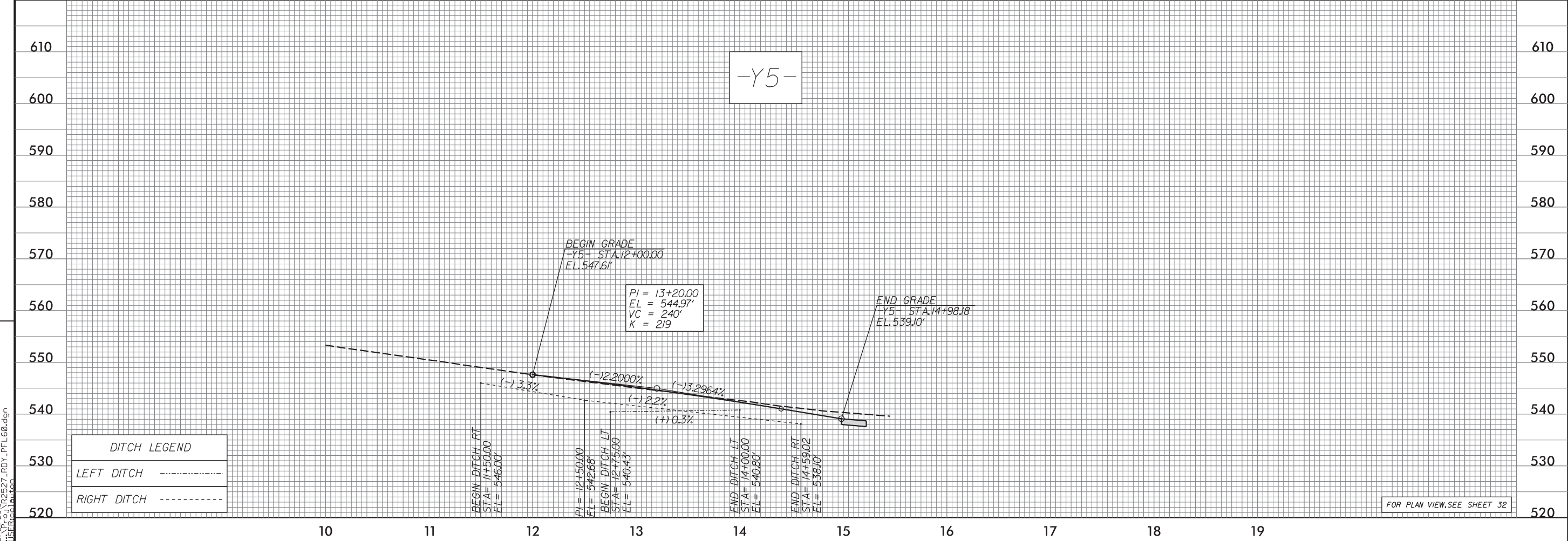
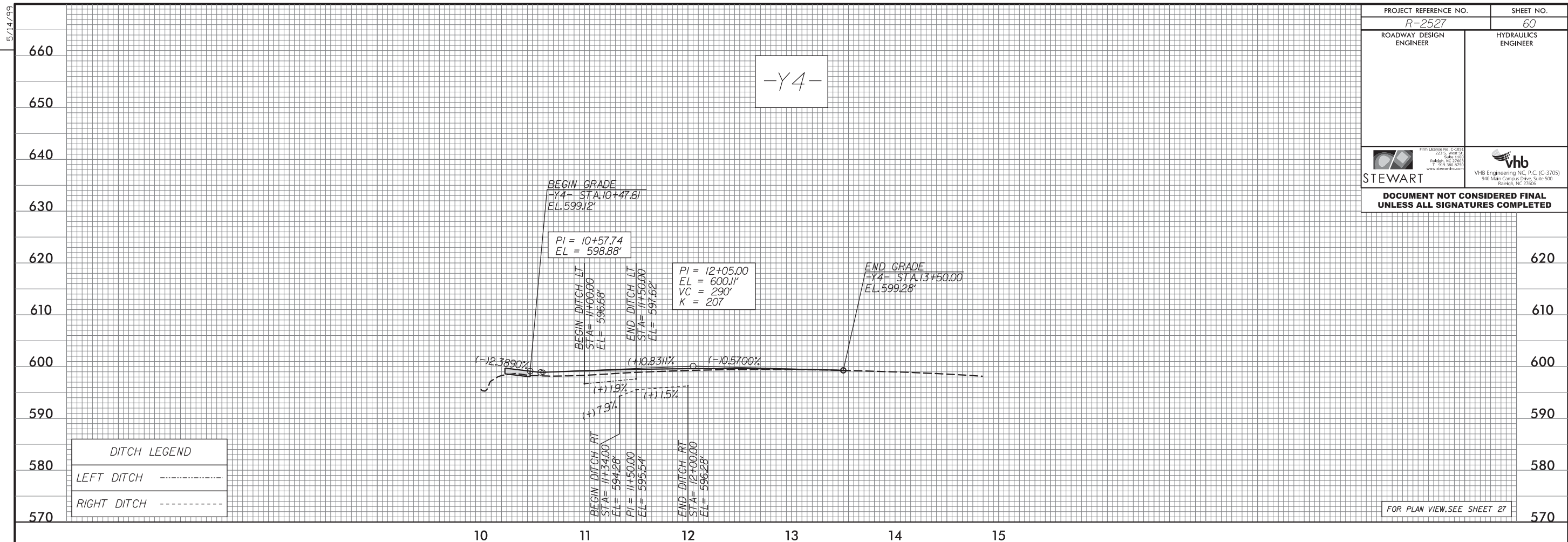

2/24/2018 R2527_RDY_PFL59.dgn
JES:ELC

REVISIONS



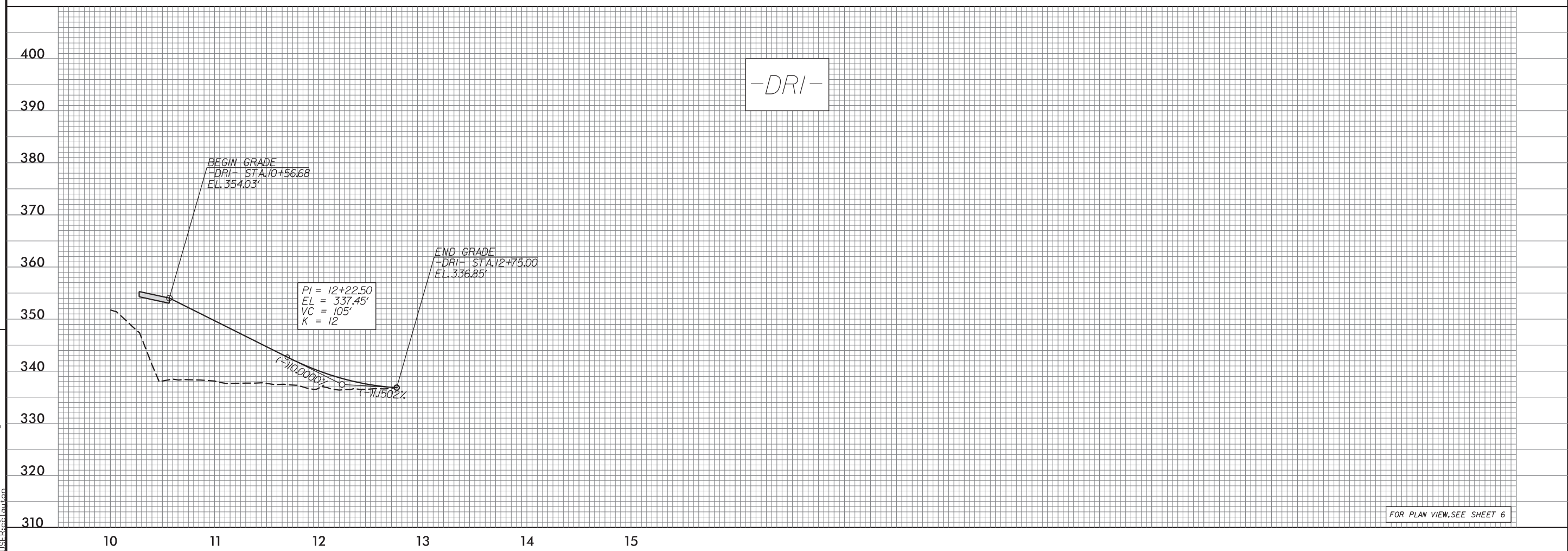
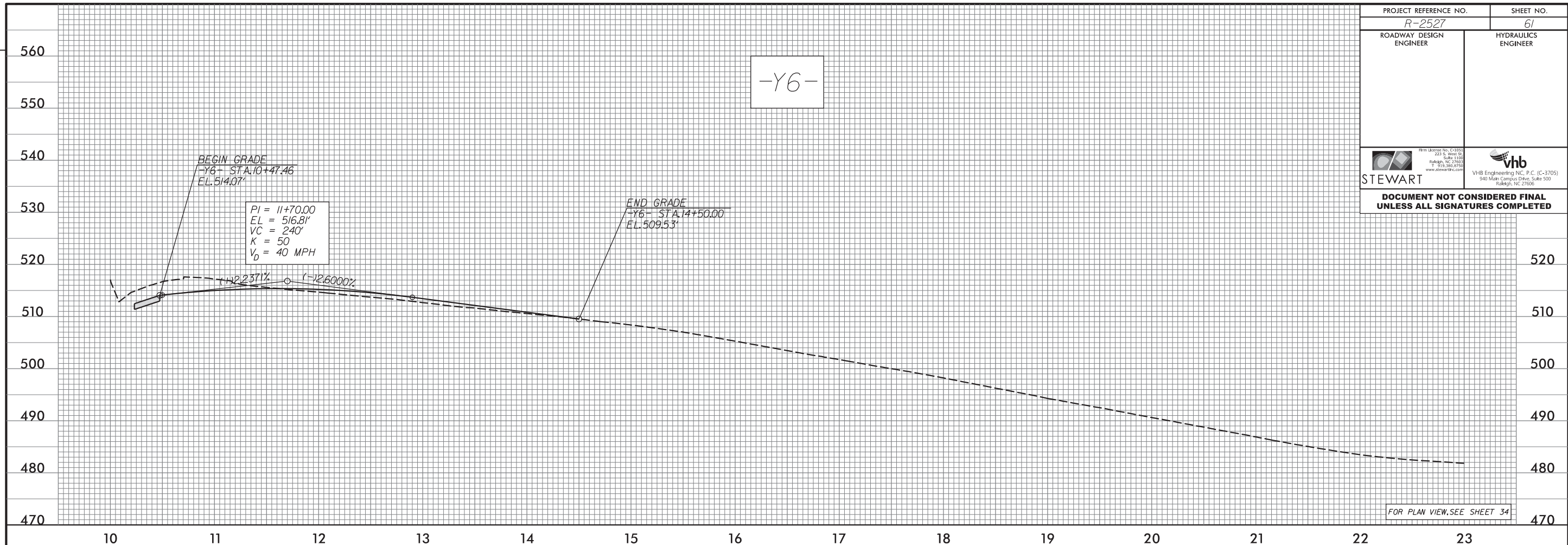

2/24/2018 R2527_RDY_PFL60.dgn
11:55:10 AM

PROJECT REFERENCE NO. <i>R-2527</i>	SHEET NO. <i>61</i>
ROADWAY DESIGN ENGINEER	HYDRAULICS ENGINEER
 STEWART <small>1800 Lakeside Dr., Suite 100 Raleigh, NC 27603 P: 919.386.2700 www.stewartinc.com</small>	 VHB <small>VHB Engineering NC, P.C. (C-3705) 940 Mark Campus Drive, Suite 500 Raleigh, NC 27606</small>
DOCUMENT NOT CONSIDERED FINAL UNLESS ALL SIGNATURES COMPLETED	



REVISIONS

2/24/2018 R2527_RDY_PFL61.dgn
JSE:rlc

PROJECT REFERENCE NO. <i>R-2527</i>	SHEET NO. <i>62</i>
ROADWAY DESIGN ENGINEER	HYDRAULICS ENGINEER
 STEWART	 VHB Engineering NC, P.C. (C-3705) 940 Main Campus Drive, Suite 500 Raleigh, NC 27606

DOCUMENT NOT CONSIDERED FINAL UNLESS ALL SIGNATURES COMPLETED

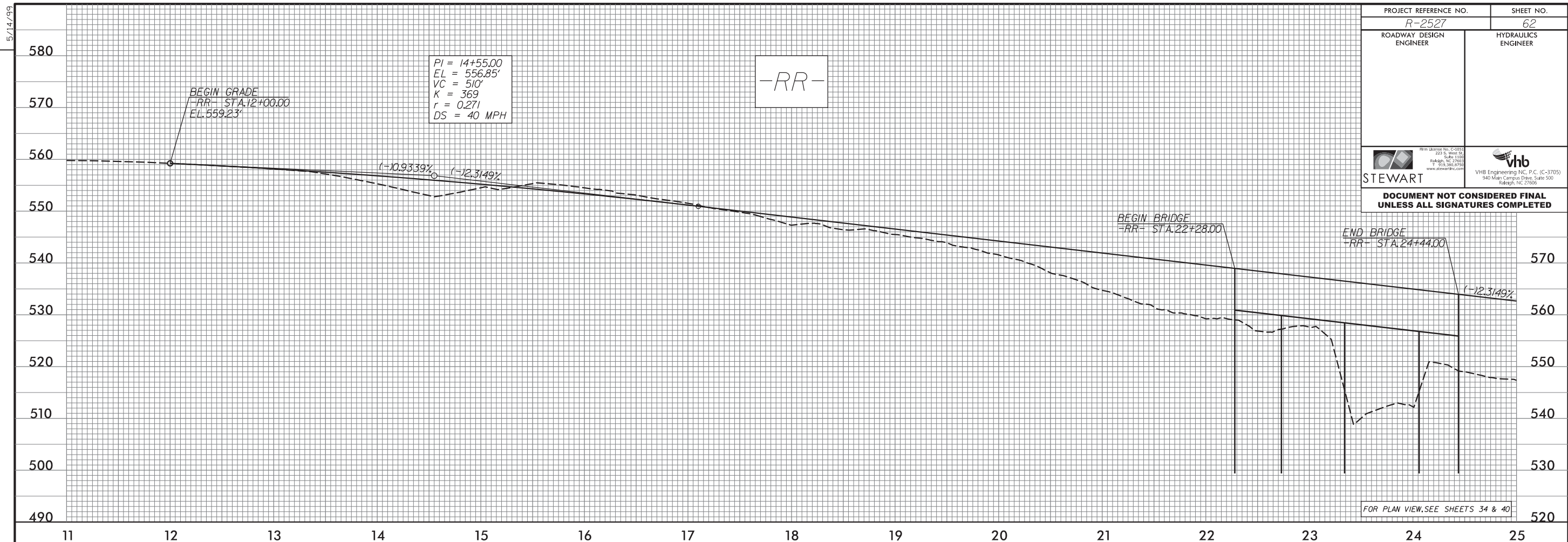

FOR PLAN VIEW, SEE SHEETS 34 & 40

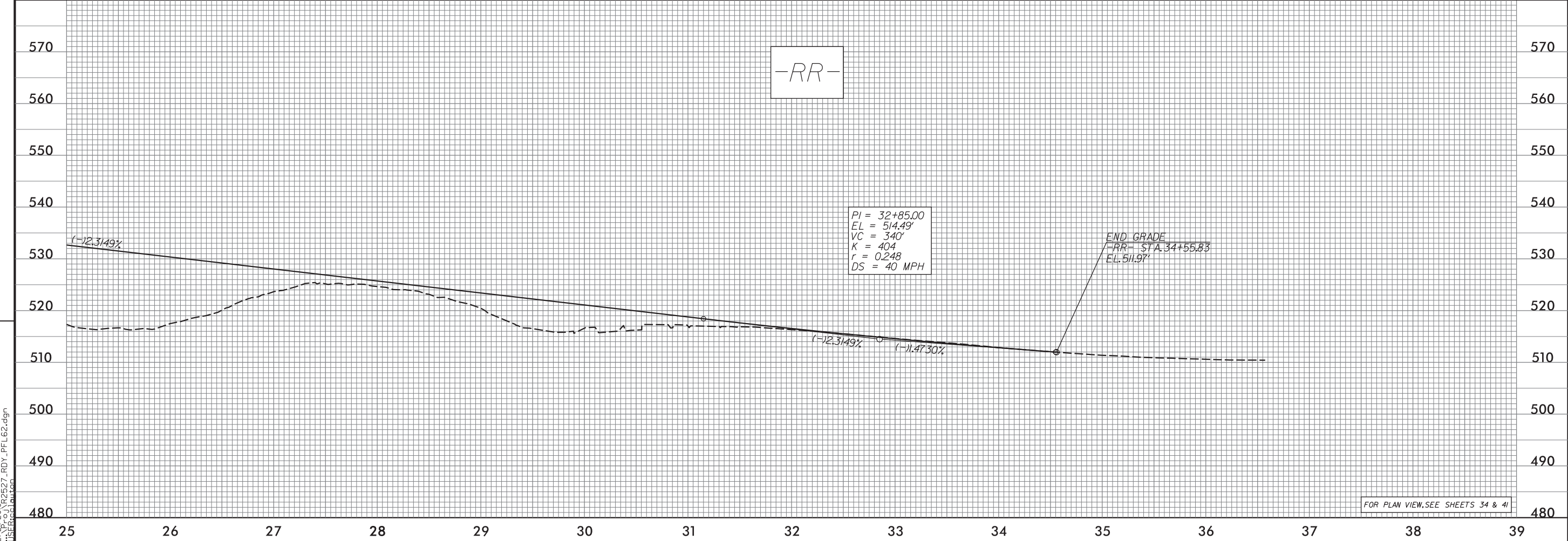

FOR PLAN VIEW, SEE SHEETS 34 & 41

REVISIONS

2/24/2018 R2527_RDY_PFL62.dgn
JES:ELC

5/14/99