

09/08/19

TIP PROJECT: I-2513AA/AB

See Sheet 1A For Index of Sheets
See Sheet 1B For Conventional Symbols

STATE OF NORTH CAROLINA
DIVISION OF HIGHWAYS

BUNCOMBE COUNTY

STATE	STATE PROJECT REFERENCE NO.	SHEET NO.	TOTAL SHEETS
N.C.	I-2513AA/AB	1	
STATE PROJ. NO.	F.A. PROJ. NO.	DESCRIPTION	
34165.1.11/34165.1.12	0026024 /0026025	P.E.	
34165.2.14/34165.2.16	0026024 /0026025	RW	
34165.2.15/34165.2.17	0026024 /0026025	UTIL.	
34165.3.6/34165.3.7	0026024 /0026025	CONST.	

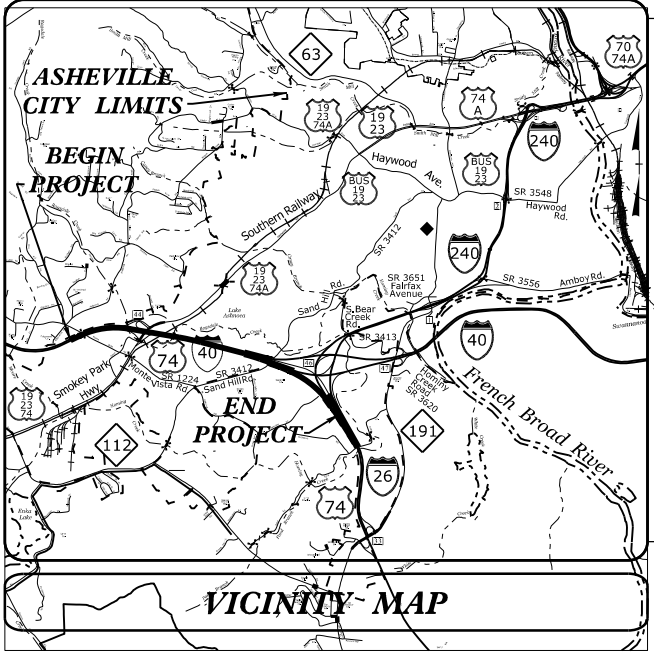

REVISED 75% PLANS
10/26/2022

LOCATION: I-40 FROM EAST OF SR 1224 (MONTE VISTA RD) TO PAVEMENT JOINT WEST OF SR 3412 (SAND HILL RD).
I-26 FROM POND ROAD BRIDGE TO I-26/I-40/I-240 INTERCHANGE.
INCLUDES INITIAL IMPROVEMENTS AT I-40EB TO I-26EB RAMP AND US 1923 (SMOKEY PARK HIGHWAY)

TYPE OF WORK: GRADING, DRAINAGE, PAVING, STRUCTURES, RETAINING WALLS, SOUND WALLS, AND ITS

PERMIT DRAWING
SHEET 1 OF 25

WETLAND AND SURFACE WATER IMPACTS PERMIT

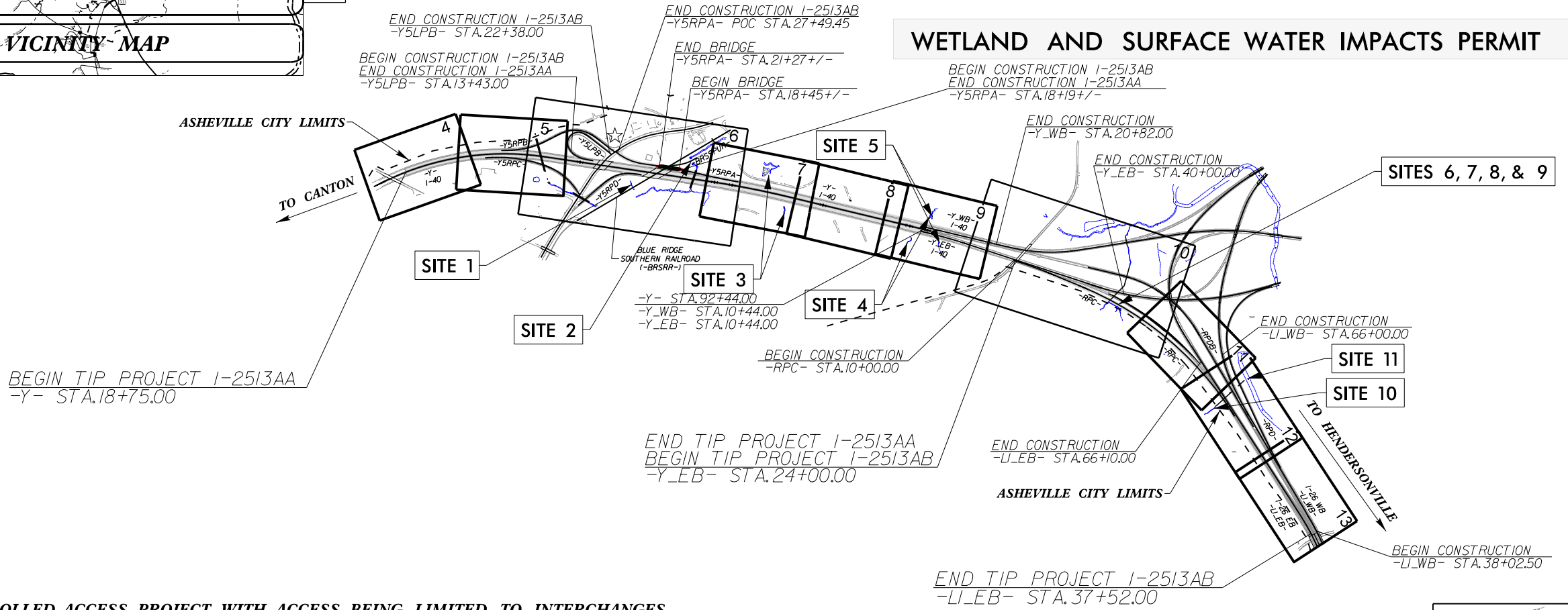

THIS IS A CONTROLLED-ACCESS PROJECT WITH ACCESS BEING LIMITED TO INTERCHANGES
THIS PROJECT IS LOCATED WITHIN THE CITY LIMITS OF THE CITY OF ASHEVILLE
CLEARING ON THIS PROJECT WILL BE PERFORMED TO THE LIMITS ESTABLISHED BY METHOD III

★ REVISED SIGNAL

WETHERILL ENGINEERING
1223 Jones Franklin Rd.
Raleigh, N.C. 27606
License No. F-0377
Bus: 919 851 8077
Fax: 919 851 8107

TRANSPORTATION PLANNING/DESIGN - BRIDGE/STRUCTURE DESIGN
CIVIL/SITE DESIGN - GIS/GPS - CONSTRUCTION OBSERVATION

CONTRACT:

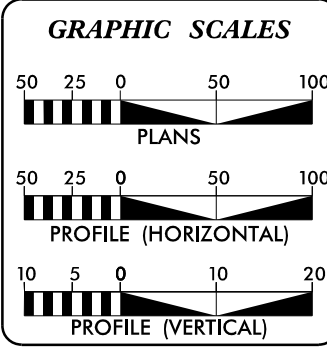

DESIGN DATA

ADT 2024 =	95,100
ADT 2040 =	118,800
K =	9 %
D =	55 %
T =	11 % *
V =	60 MPH
* TTST =	8% DUAL 3%
FUNC CLASS =	INTERSTATE
STATEWIDE TIER	

PROJECT LENGTH

LENGTH ROADWAY TIP PROJECT I-2513AA/AB =	2.656 MI
TOTAL LENGTH TIP PROJECT I-2513AA/AB =	2.656 MI

KCI ASSOCIATES OF N.C., P.A.
4505 Falls of Neuse Road, Suite 400
Raleigh, NC 27609
Phone (919) 783-9214
NC Firm License No: C-0764

2018 STANDARD SPECIFICATIONS

RIGHT OF WAY DATE:
NOVEMBER 15, 2022

LETTING DATE:
NOVEMBER 21, 2023

CHARLES L. FLOWE, P.E.
PROJECT ENGINEER

BARRY C. SMITH, P.E.
PROJECT DESIGN ENGINEER

KEVIN E. MOORE, P.E.
NCDOT CONTACT

HYDRAULICS ENGINEER



SIGNATURE: _____ P.E.

ROADWAY DESIGN ENGINEER

SIGNATURE: _____ P.E.

DOCUMENT NOT CONSIDERED FINAL
UNLESS ALL SIGNATURES COMPLETED

10/29/2022
G:\pwworking\aecom_ds2\l_na_2020\d0244737\I2513AA_hyd_prm_t.sh.dgn
USER: MHarvey

PROJECT REFERENCE NO. 1-2513AA/AB	SHEET NO. 2D-1
RW SHEET NO.	
ROADWAY DESIGN ENGINEER	HYDRAULICS ENGINEER
INCOMPLETE PLANS DO NOT USE FOR R/W ACQUISITION	
DOCUMENT NOT CONSIDERED FINAL UNLESS ALL SIGNATURES COMPLETED	
 KCI ASSOCIATES OF N.C., P.A. 4505 Falls of Neuse Road, Suite 400 Raleigh, NC 27609-4270 Phone (919) 783-9214 NC Firm License No. C-0764	
 1223 Jones Franklin Rd. Raleigh, N.C. 27606 License No. F-43377 Bus: 919 851 9077 Fax: 919 851 8107	
TRANSPORTATION PLANNING/DESIGN - BRIDGE/STRUCTURE DESIGN CIVIL/SITE DESIGN - GIS/GPS - CONSTRUCTION OBSERVATION	

PERMIT DRAWING
SHEET 2 OF 25

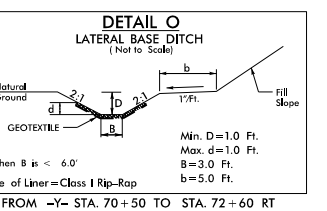
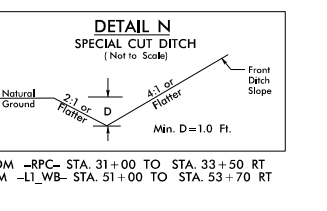
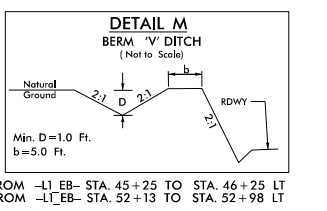
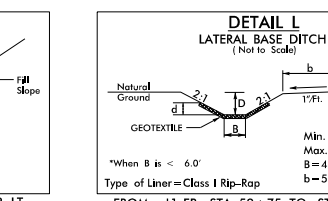
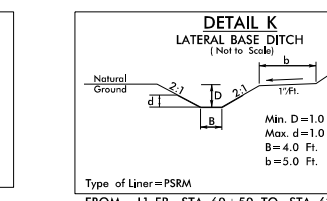
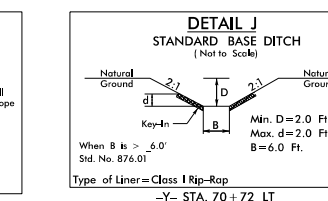
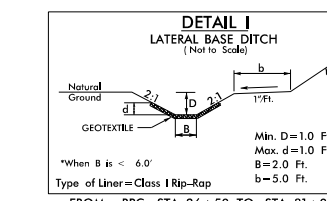
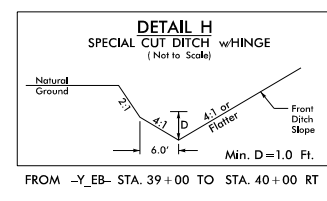
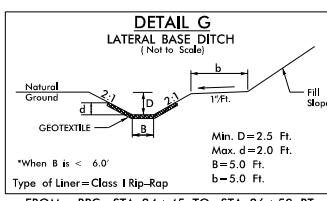
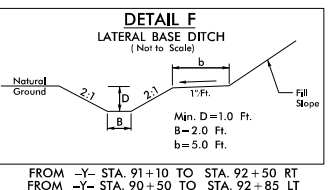
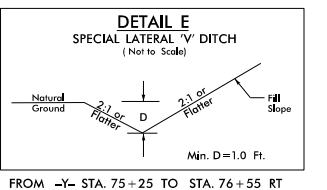
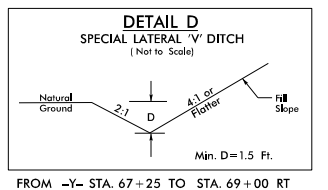
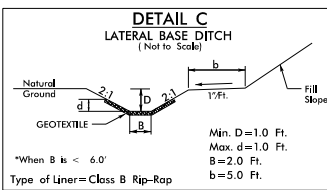
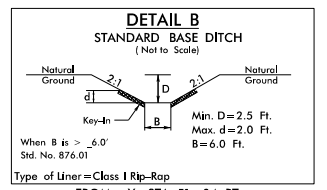
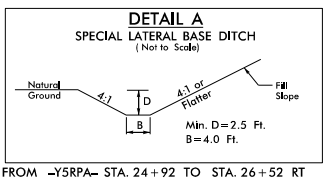

DETAIL P
RIP-RAPPED ENERGY DISSIPATOR BASIN

DIM. (ft)	1	2	?
A	2.5	2.0	?
B	1.7	1.4	?
C	1.4	0.5	?
D	1.4	0.5	?
E	7.0	2.5	?
F	18.0	9.0	?
G	14.0	7.5	?

ALL DIMENSIONS APPROXIMATE

BASIN #	LOCATION (AT OUTLET)
1	-Y- 92+94 LT
2	-Y- 93+22 LT

7/08

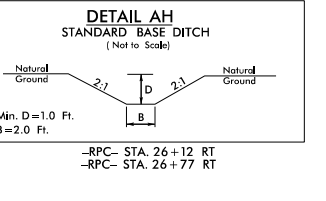
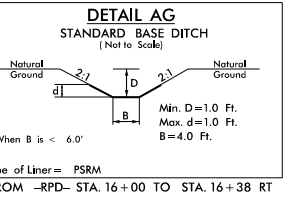
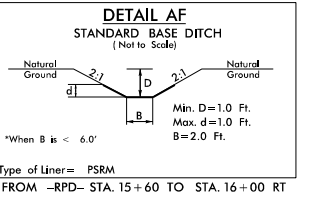
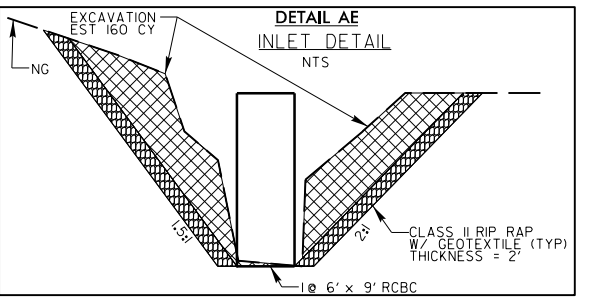
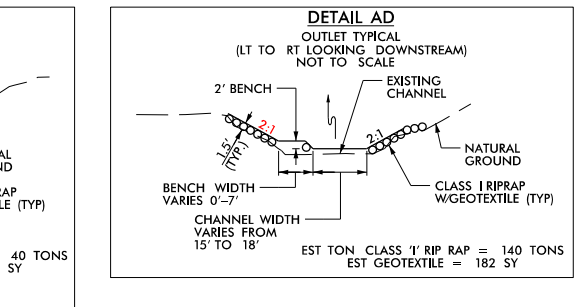
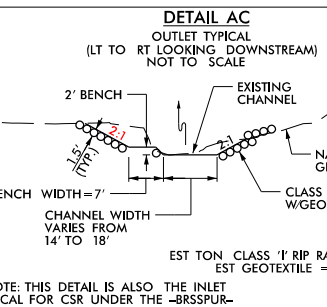
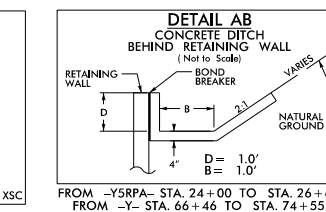
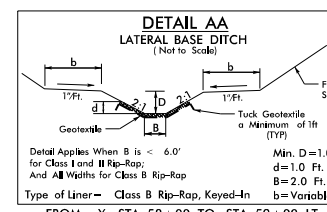
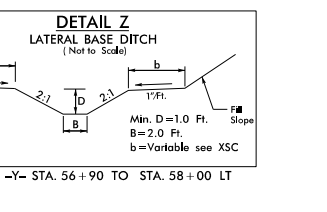
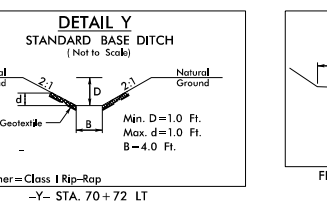
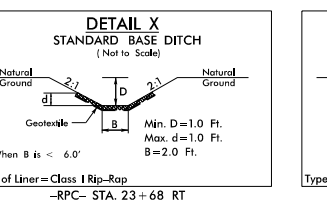
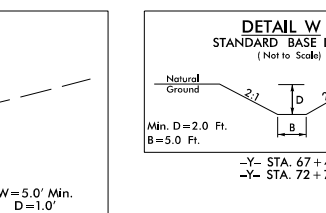
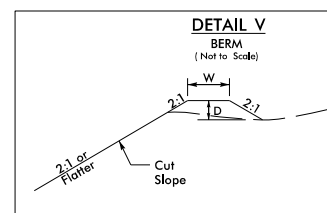
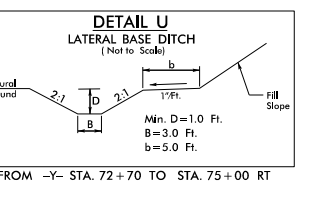
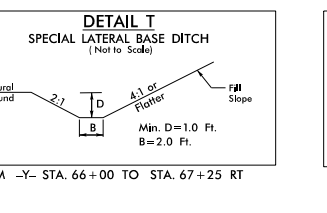
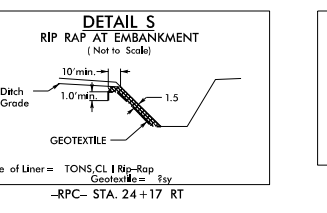
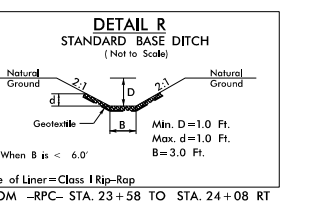
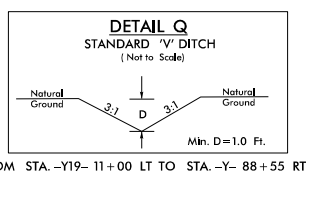

STEP POOL STRUCTURES

PROJECT REFERENCE NO. I-25/3AA/AB	SHEET NO. 2D-2
R/W SHEET NO. ROADWAY DESIGN ENGINEER	HYDRAULICS ENGINEER
INCOMPLETE PLANS DO NOT USE FOR R/W ACQUISITION	
DOCUMENT NOT CONSIDERED FINAL UNLESS ALL SIGNATURES COMPLETED	

PERMIT DRAWING
SHEET 3 OF 25

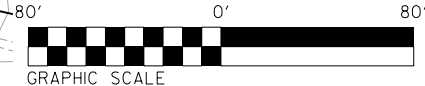

REVISIONS

8/17/99

10/29/2022
c:\pwworking\aecom_da21_na_2020_d0244737\Detail_StepDownPool.dgn
D:\pwworking\aecom_da21_na_2020_d0244737\Detail_StepDownPool.dgn

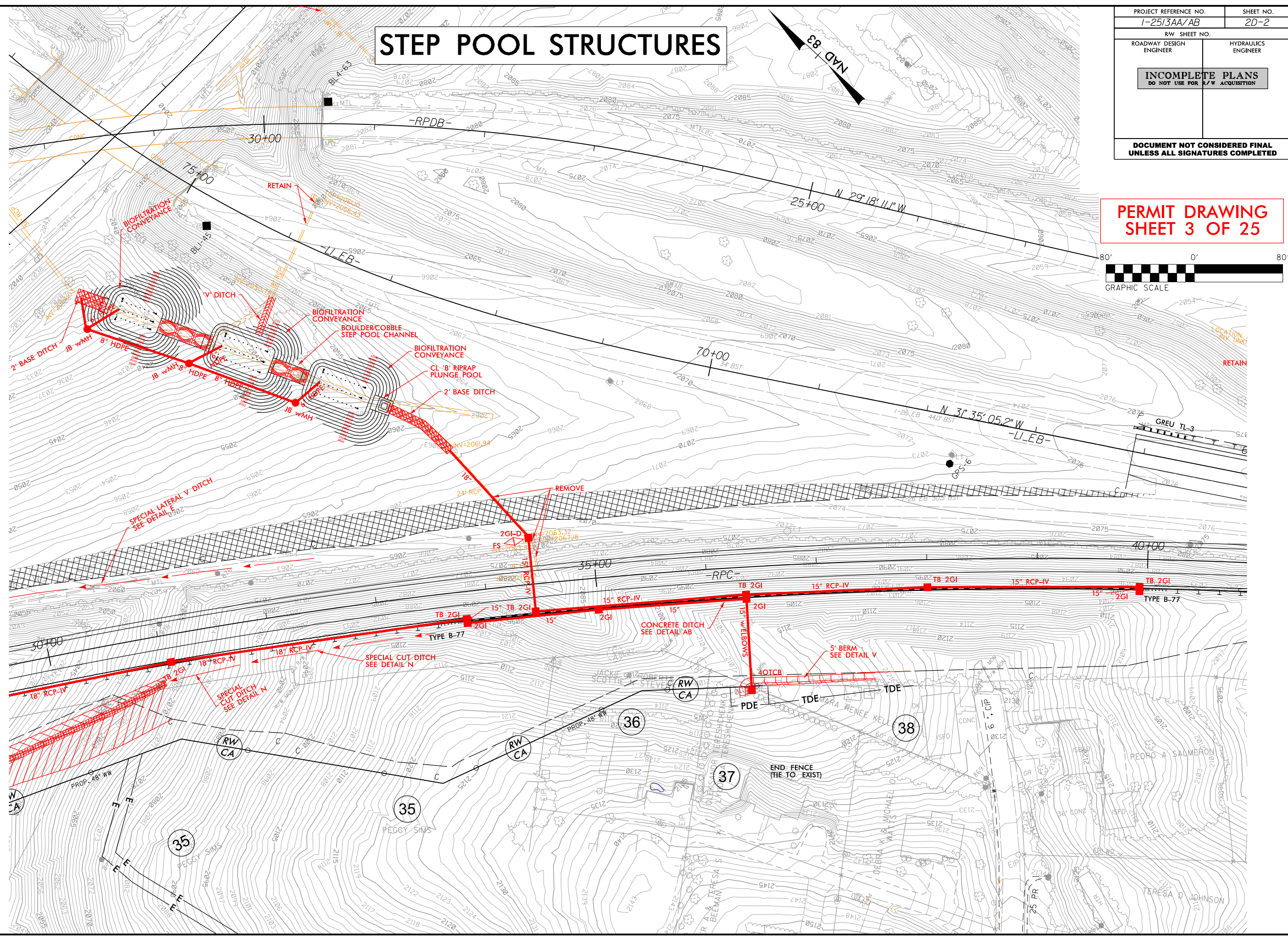

**PERMIT DRAWING
SHEET 6 OF 25**

PROJECT REFERENCE NO. I-25/3AA/AB	SHEET NO. 6
RW SHEET NO.	
ROADWAY DESIGN ENGINEER	HYDRAULICS ENGINEER
INCOMPLETE PLANS DO NOT USE FOR R/W ACQUISITION	
DOCUMENT NOT CONSIDERED FINAL UNLESS ALL SIGNATURES COMPLETED	

SITE 2

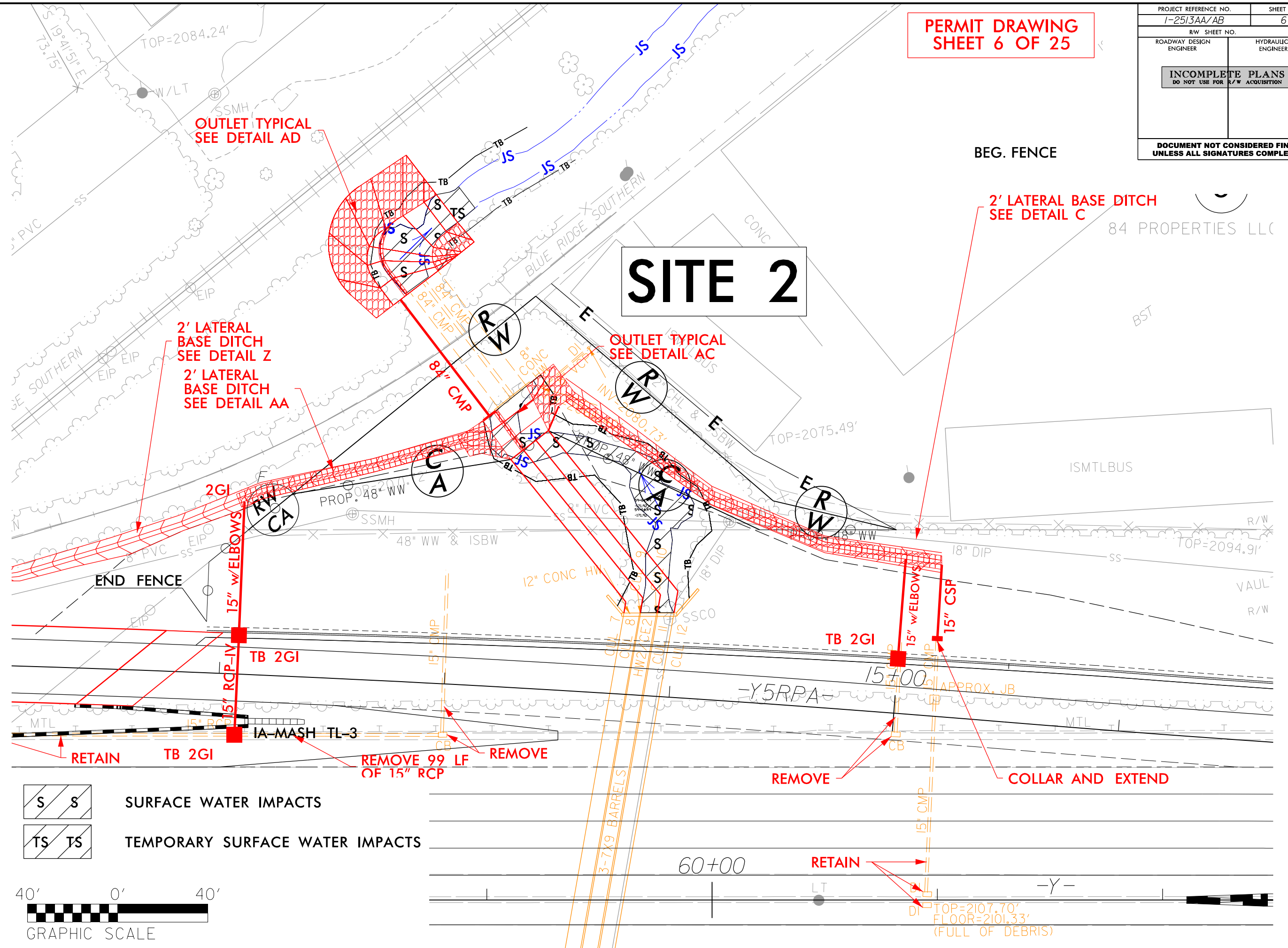

S S SURFACE WATER IMPACTS
TS TS TEMPORARY SURFACE WATER IMPACTS

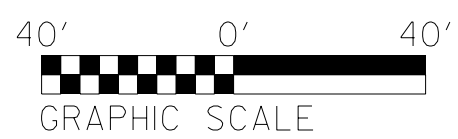

REVISIONS

10/28/2022
 C:\pwworking\eeecom_ds21_na_2020\40244737\12513AA_hyd_prm_psh_06E_2.dgn
 M:\pwworking\eeecom_ds21_na_2020\40244737\12513AA_hyd_prm_psh_06E_2.dgn



BEG. FENCE

84 PROPERTIES LLC

ISMTLBUS

VAULT
R/W

60+00

RETAIN

-Y-

DI
 TOP=2107.70'
 FLOOR=2101.33'
 (FULL OF DEBRIS)

NO.	REVISIONS

PROJECT REFERENCE NO. 7-25144/AR	SHEET NO. 6
ROADWAY DESIGN ENGINEER	HYDRAULIC ENGINEER
INCOMPLETE PLANS DO NOT USE FOR R/W ACQUISITION	
DOCUMENT NOT CONSIDERED FINAL UNLESS ALL SIGNATURES COMPLETED	
 KCI KCI CONSULTANTS, INC. 10100 PARKWAY 15 SUITE 100 ASHEVILLE, NC 28705 PHONE: 828.251.1000 FAX: 828.251.1001 WWW.KCI-CONSULTANTS.COM	

PERMIT DRAWING
SHEET 7 OF 25

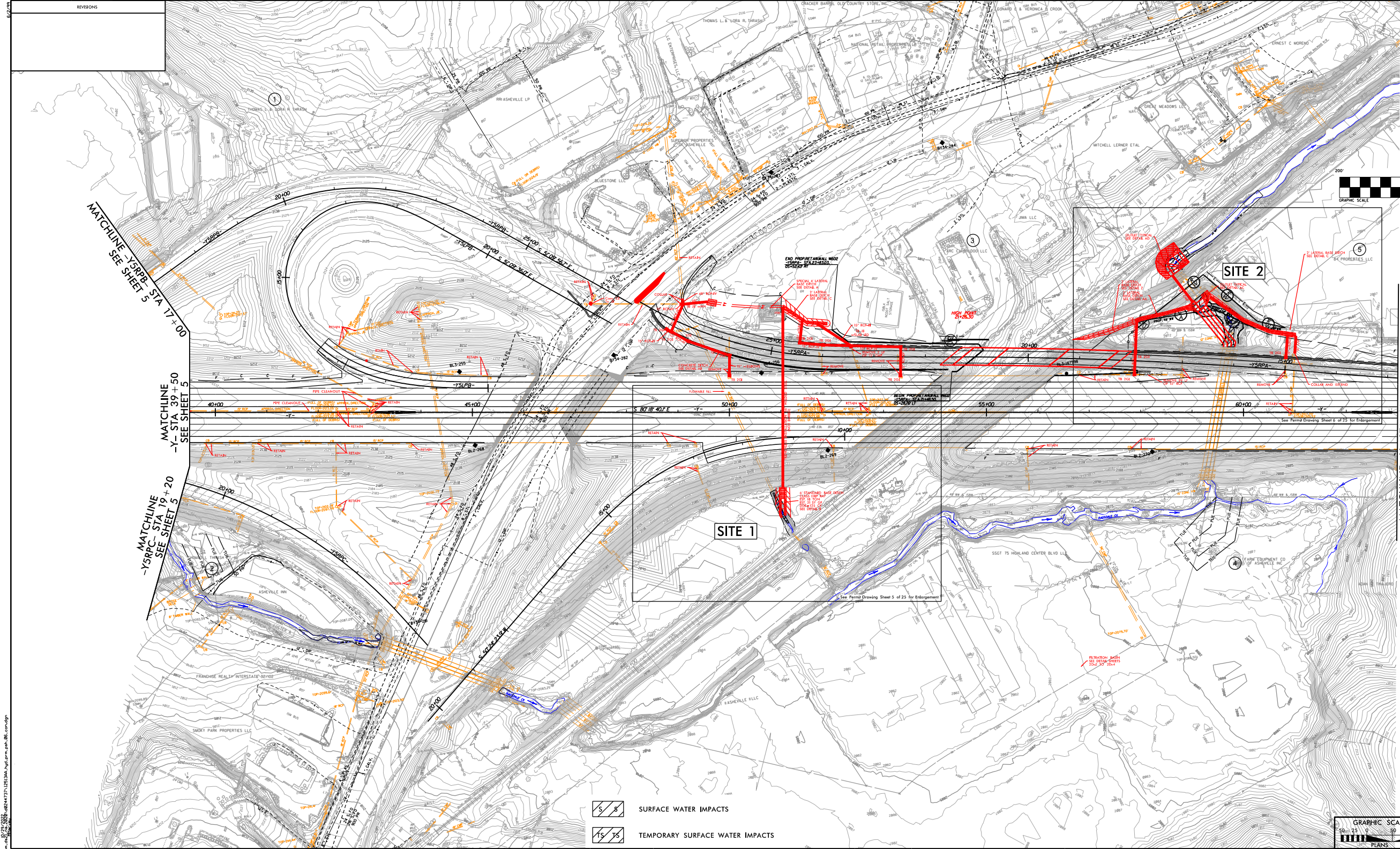



MATCHLINE -Y-5RPP- STA 17+00
SEE SHEET 5

MATCHLINE -Y- STA 39+50
SEE SHEET 5

MATCHLINE -Y5RPP- STA 19+20
SEE SHEET 5

MATCHLINE -Y- STA 63+00 - SEE SHEET 7

-  SURFACE WATER IMPACTS
-  TEMPORARY SURFACE WATER IMPACTS

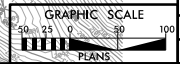

★ REVISED SIGNAL

FOR -Y-AT- & -Y-RT- PROFILES SEE SHEETS 16 & 17
FOR -Y5RPP- PROFILE SEE SHEET 24
FOR -Y5RPP- PROFILE SEE SHEET 25
FOR DRAINAGE DETAILS SEE SHEET 20-1

LOCATION:	COUNTY:
DATE:	DATE:

© 2014 KCI CONSULTANTS, INC. ALL RIGHTS RESERVED. THIS DRAWING IS THE PROPERTY OF KCI CONSULTANTS, INC. AND IS NOT TO BE REPRODUCED OR TRANSMITTED IN ANY FORM OR BY ANY MEANS, ELECTRONIC OR MECHANICAL, WITHOUT THE WRITTEN PERMISSION OF KCI CONSULTANTS, INC.

5/14/99

PROJECT REFERENCE NO. I-25/3AA/AB	SHEET NO.
ROADWAY DESIGN ENGINEER	HYDRAULICS ENGINEER
INCOMPLETE PLANS DO NOT USE FOR A/W ACQUISITION	
DOCUMENT NOT CONSIDERED FINAL UNLESS ALL SIGNATURES COMPLETED	

SITE 1

-Y- 51+04

PERMIT DRAWING
SHEET 8 OF 25

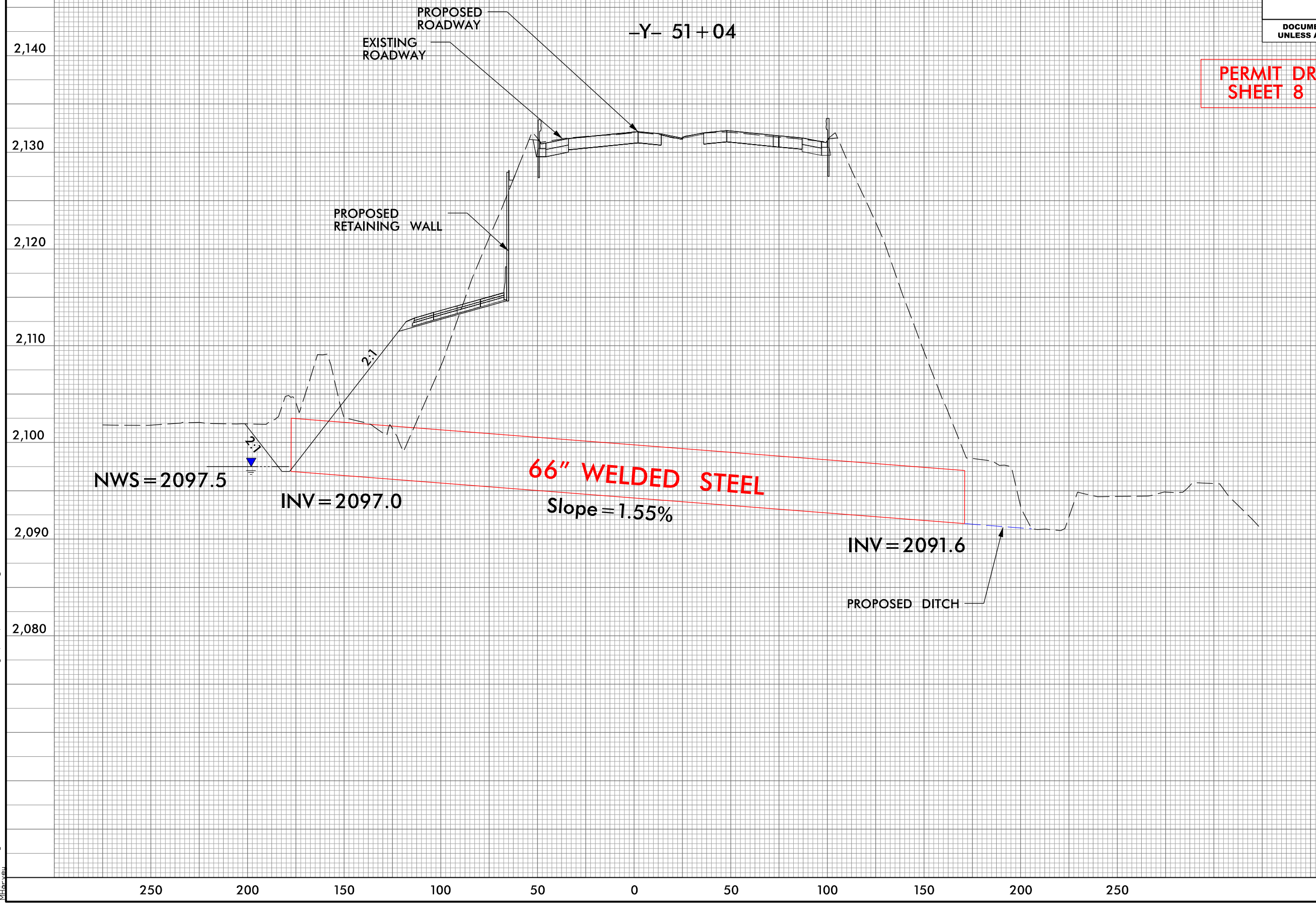

10/29/2022
10:29:20 AM
C:\working\oecom.ds21.no.2020\0244737\I-2513AA_hyd_perm.pfl.border.dgn

5/14/99
10/29/2022
\\sbl\work\engineering\oeocom.ds21.no.2020\0244737\1-2513AA_hyd.prm.plt.border.dgn

PROJECT REFERENCE NO. 1-2513AA/AB	SHEET NO.
ROADWAY DESIGN ENGINEER	HYDRAULICS ENGINEER
INCOMPLETE PLANS DO NOT USE FOR R/W ACQUISITION	
DOCUMENT NOT CONSIDERED FINAL UNLESS ALL SIGNATURES COMPLETED	

SITE 2

PERMIT DRAWING
SHEET 9 OF 25

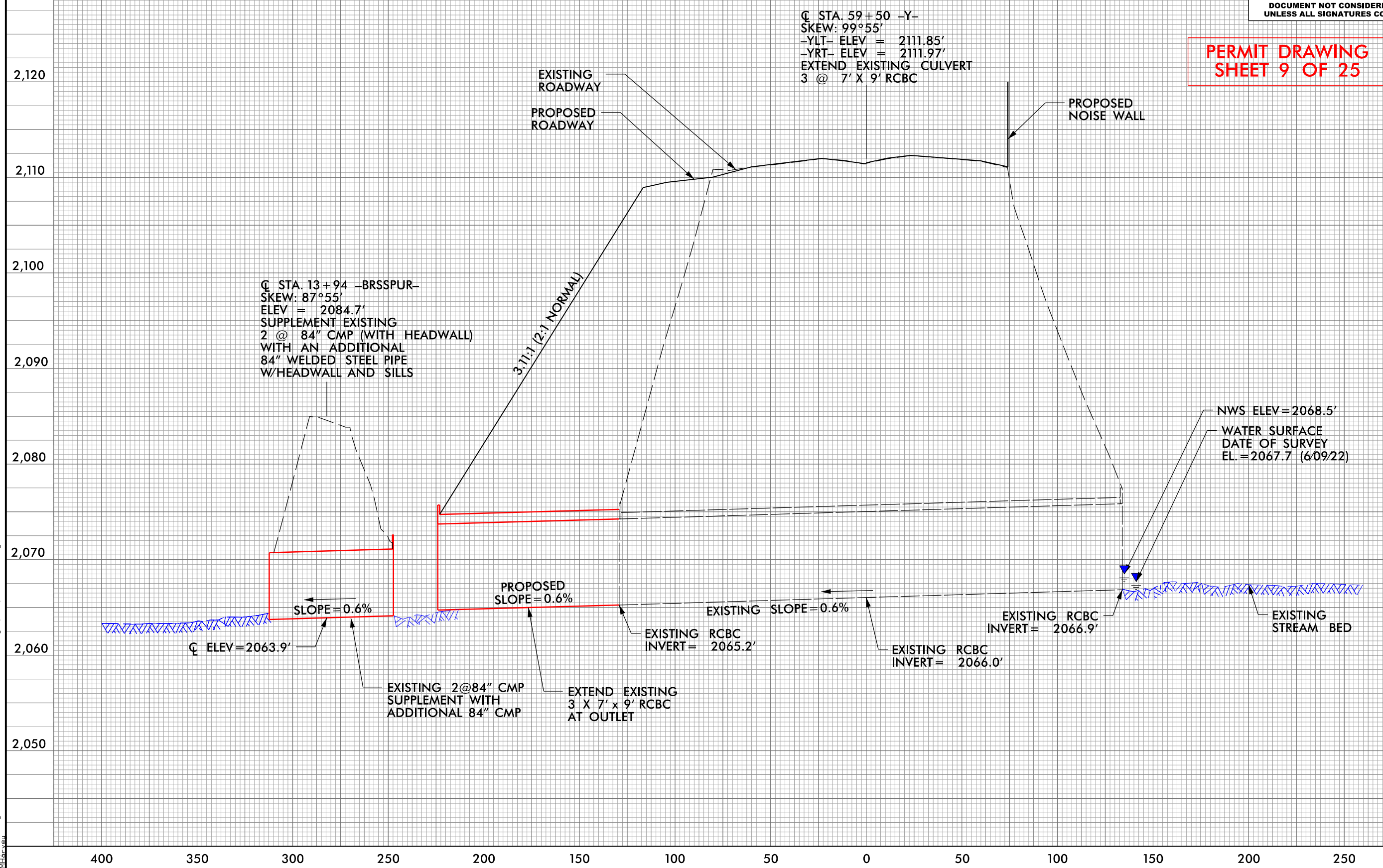

5/14/99

10/23/2022
ng\aeocom\csharav...
d0244737\12513AA_hyd.prm.pst_07.dgn

- FILL IN WETLAND
- SURFACE WATER IMPACTS
- TEMPORARY SURFACE WATER IMPACTS
- WETLAND EXCAVATION
- HAND CLEARING (NON-GRUBBING)

**PERMIT DRAWING
SHEET 10 OF 25**

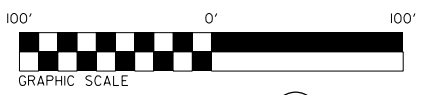

PROJECT REFERENCE NO. 1-2513AA/AB	SHEET NO. 7
RW SHEET NO.	
ROADWAY DESIGN ENGINEER	HYDRAULICS ENGINEER
INCOMPLETE PLANS DO NOT USE FOR R/W ACQUISITION	
DOCUMENT NOT CONSIDERED FINAL UNLESS ALL SIGNATURES COMPLETED	
	KCI ASSOCIATES OF N.C., P.A. 4505 Falls of Neuse Road, Suite 400 Raleigh, NC 27609-6270 Phone (919) 783-0214 NC Firm License No. C-0764
	1223 Jones Franklin Rd. Raleigh, N.C. 27606 License No. F-43377 Bus: 919 851 9077 Fax: 919 851 8107
TRANSPORTATION PLANNING/DESIGN - BRIDGE/STRUCTURE DESIGN CIVIL/SITE DESIGN - GIS/GIS/PS - CONSTRUCTION OBSERVATION	

MATCHLINE -Y- STA 63+00 - SEE SHEET 6

MATCHLINE -Y- STA 75+00 - SEE SHEET 8

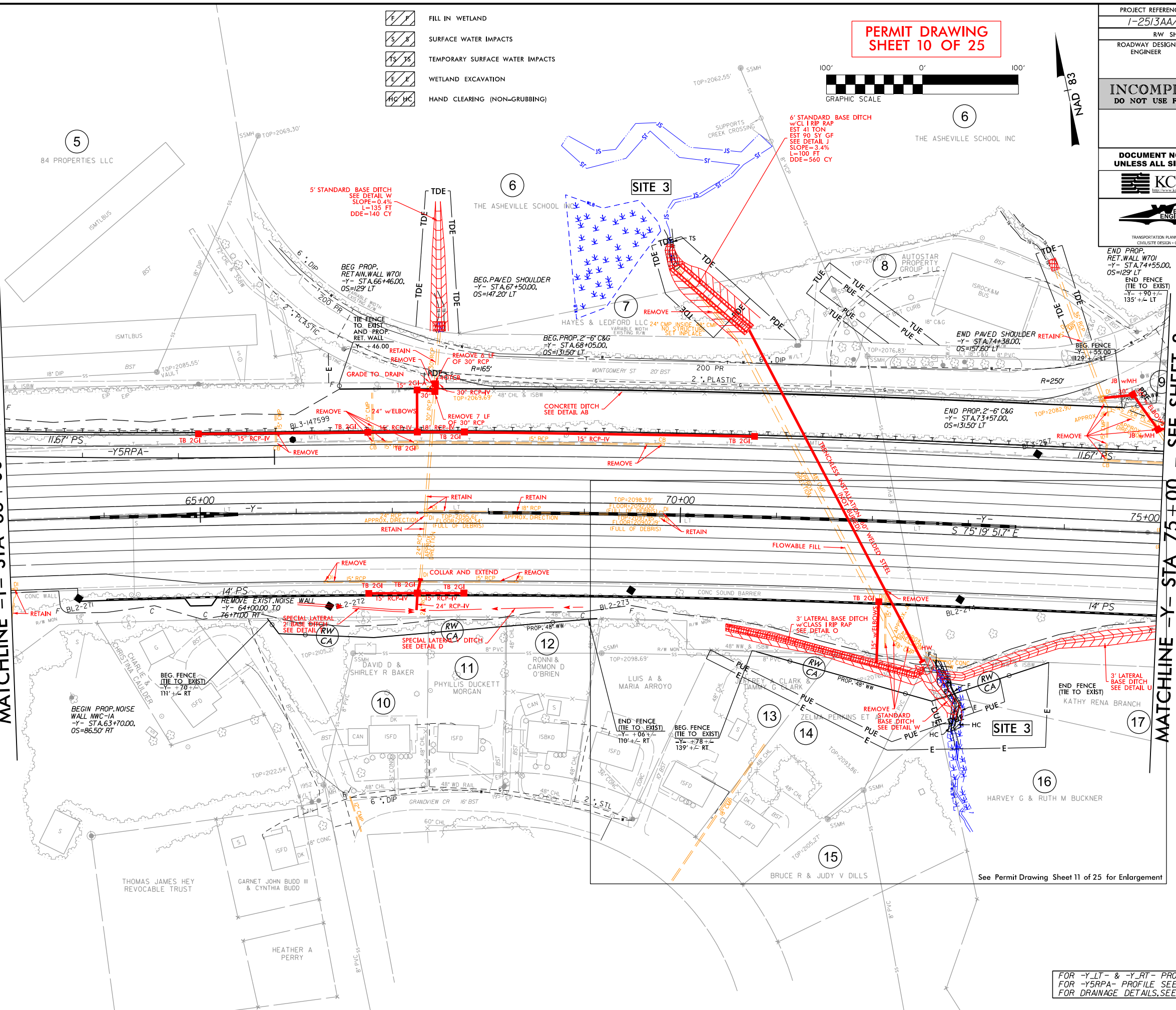





FOR -Y-LT- & -Y-RT- PROFILES SEE SHEET 18
FOR -Y5RPA- PROFILE SEE SHEET 23
FOR DRAINAGE DETAILS, SEE SHEET 20-1

5/14/99



REVISIONS

\\aeocom-ds-2\proj\2020\12513AA\hyd.prm.psh.07_con.dgn

-  F F FILL IN WETLAND
-  S S SURFACE WATER IMPACTS
-  TS TS TEMPORARY SURFACE WATER IMPACTS
-  E E WETLAND EXCAVATION
-  HC HC HAND CLEARING (NON-GRUBBING)

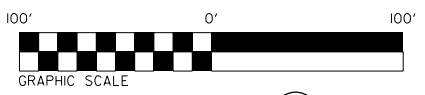
PERMIT DRAWING SHEET 12 OF 25



PROJECT REFERENCE NO. 1-2513AA/AB	SHEET NO. 7
RW SHEET NO.	HYDRAULICS ENGINEER
ROADWAY DESIGN ENGINEER	
INCOMPLETE PLANS DO NOT USE FOR R/W ACQUISITION	
DOCUMENT NOT CONSIDERED FINAL UNLESS ALL SIGNATURES COMPLETED	
	KCI ASSOCIATES OF N.C., P.A. 4505 Falls of Neuse Road, Suite 400 Raleigh, NC 27609-6270 Phone (919) 783-0214 NC Firm License No. C-0761
	1223 Jones Franklin Rd. Raleigh, N.C. 27606 License No. F-43377 Bus: 919 851 9077 Fax: 919 851 8107
TRANSPORTATION PLANNING/DESIGN - BRIDGE/STRUCTURE DESIGN CIVIL/SITE DESIGN - GIS/GPS - CONSTRUCTION OBSERVATION	

MATCHLINE -Y- STA 63+00 - SEE SHEET 6

MATCHLINE -Y- STA 75+00 - SEE SHEET 8

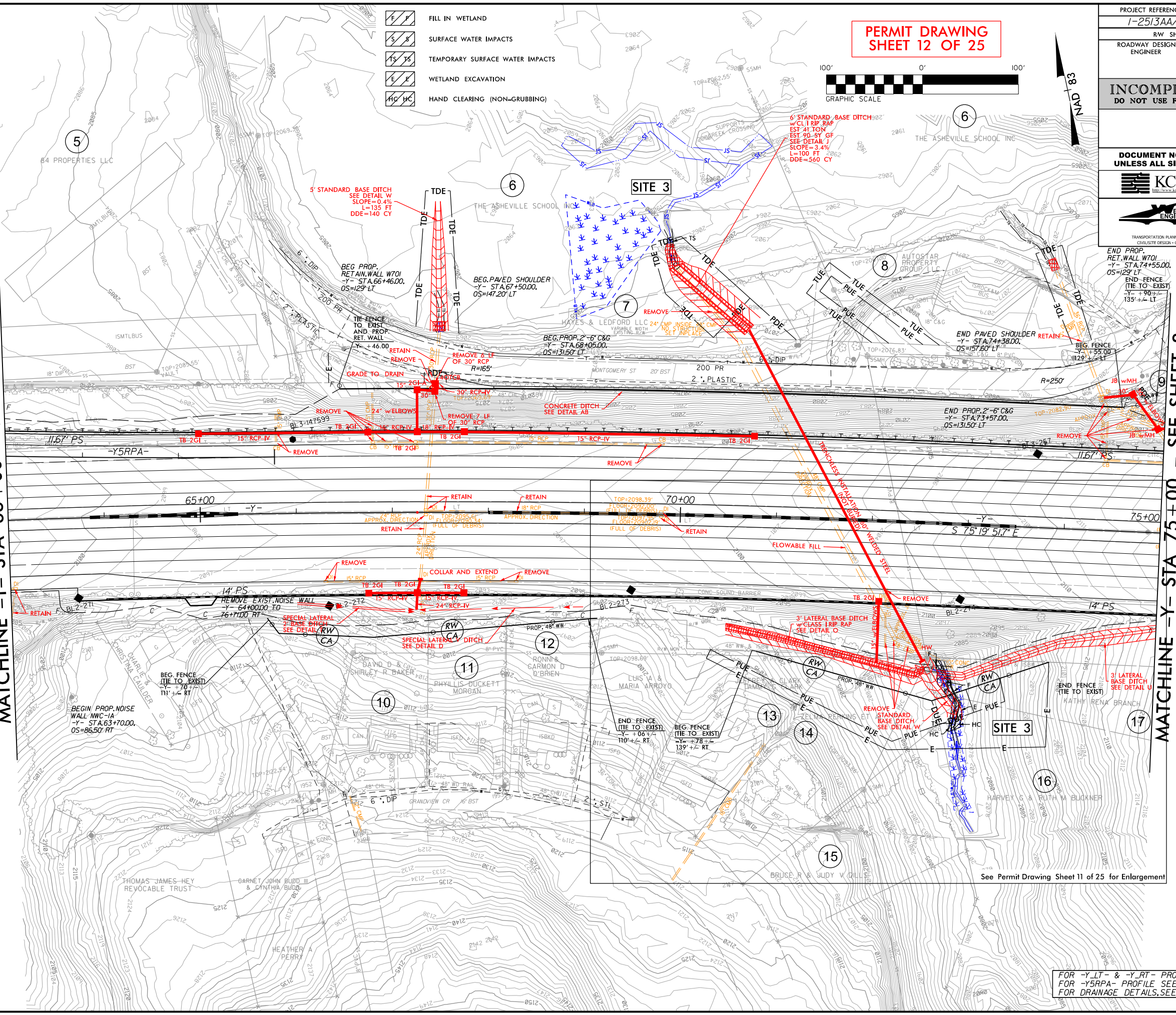

FOR -Y-LT & -Y-RT- PROFILES SEE SHEET 18
FOR -Y5RPA- PROFILE SEE SHEET 23
FOR DRAINAGE DETAILS, SEE SHEET 20-1

See Permit Drawing Sheet 11 of 25 for Enlargement

PROJECT REFERENCE NO. I-2513AA/AB	SHEET NO.
ROADWAY DESIGN ENGINEER	HYDRAULICS ENGINEER
INCOMPLETE PLANS DO NOT USE FOR R/W ACQUISITION	
DOCUMENT NOT CONSIDERED FINAL UNLESS ALL SIGNATURES COMPLETED	

SITE 3

-Y- 71+74

**PERMIT DRAWING
SHEET 13 OF 25**

5/14/99
10/29/2022
C:\working\oecom.ds21.no.2020\0244737\I-2513AA_hyd.prm.pfl.border.dgn

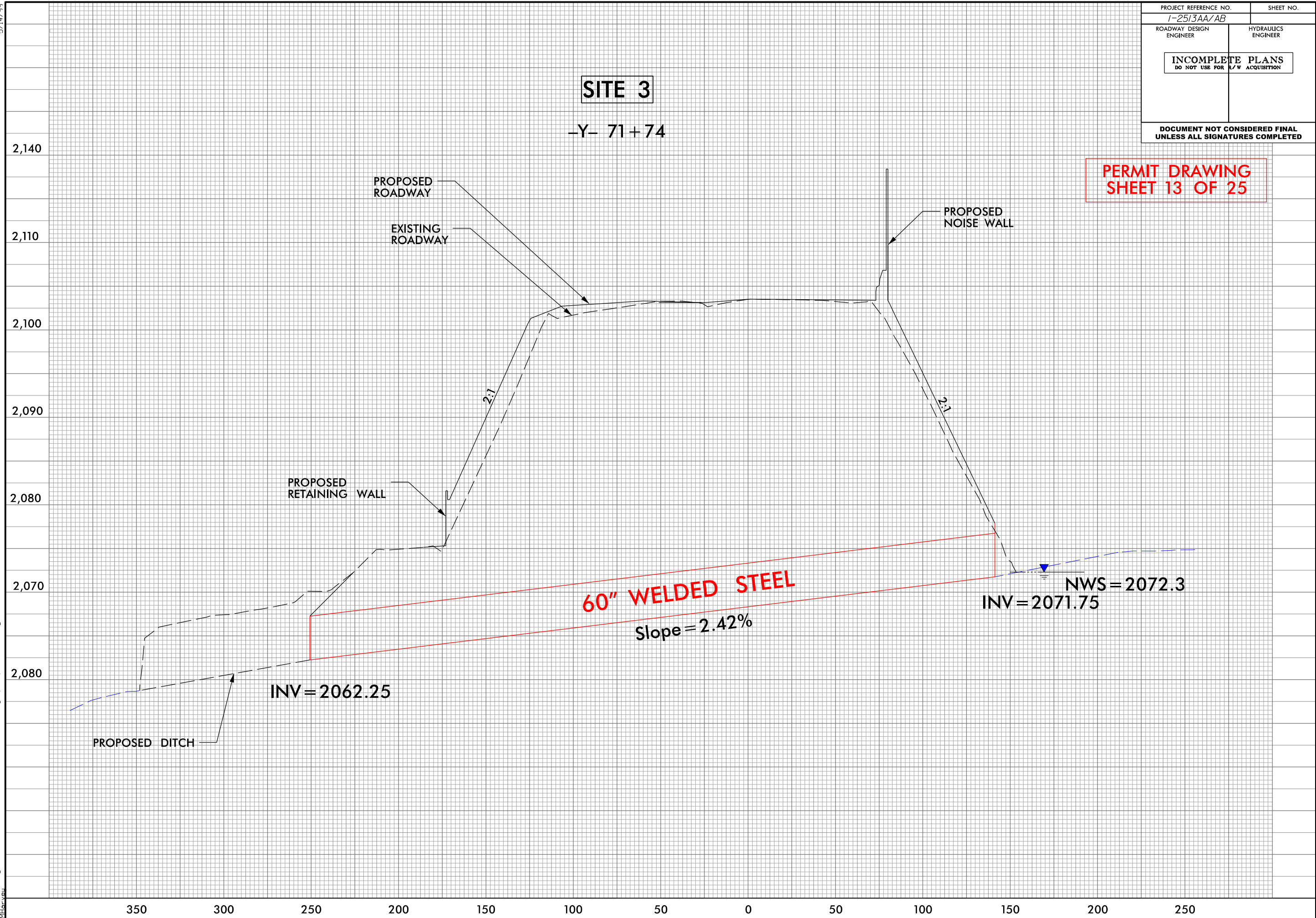

6/23/16



PROJ. REFERENCE NO.	SHEET NO.
I-2513AA/AB	X-YRT50

20 10 0 10 20 30 40 50 60 70 80 90 100 110 120 130 140 150 160 170 180 190 200 210 220 230 240 250 260 270 280

PERMIT DRAWING
SHEET 14 OF 25

SITE 3

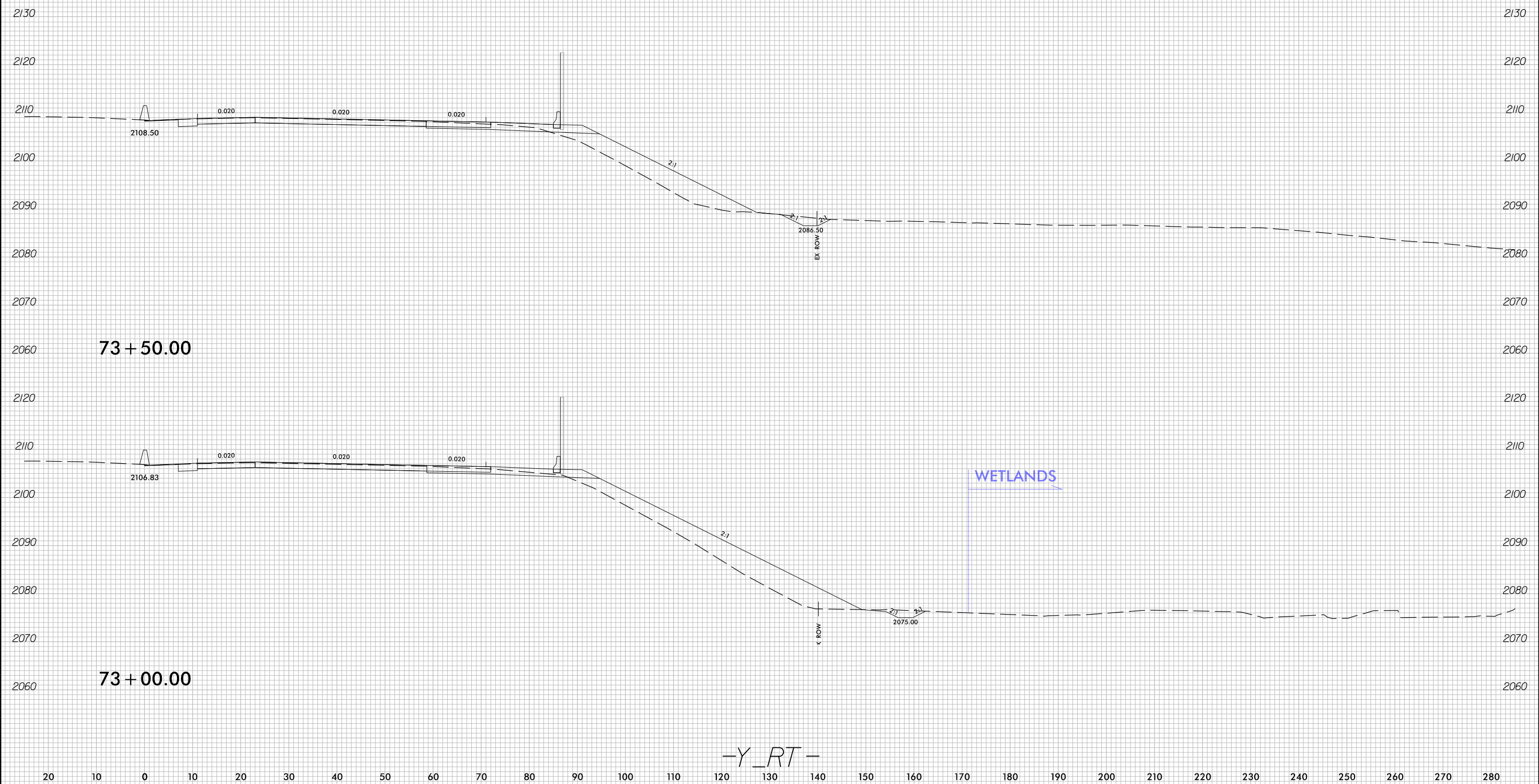

10/29/2022
C:\pwworking\aeacom\ds21_na_2020\00205719\I-2513AA_RDY_XPL_Y_RT.dgn
USER: mferveij

-Y_RT-

20 10 0 10 20 30 40 50 60 70 80 90 100 110 120 130 140 150 160 170 180 190 200 210 220 230 240 250 260 270 280

PROJECT REFERENCE NO. I-25/3AA/AB	SHEET NO. 9
RW SHEET NO.	
ROADWAY DESIGN ENGINEER	HYDRAULICS ENGINEER
INCOMPLETE PLANS DO NOT USE FOR R/W ACQUISITION	
DOCUMENT NOT CONSIDERED FINAL UNLESS ALL SIGNATURES COMPLETED	

PERMIT DRAWING
SHEET 16 OF 25

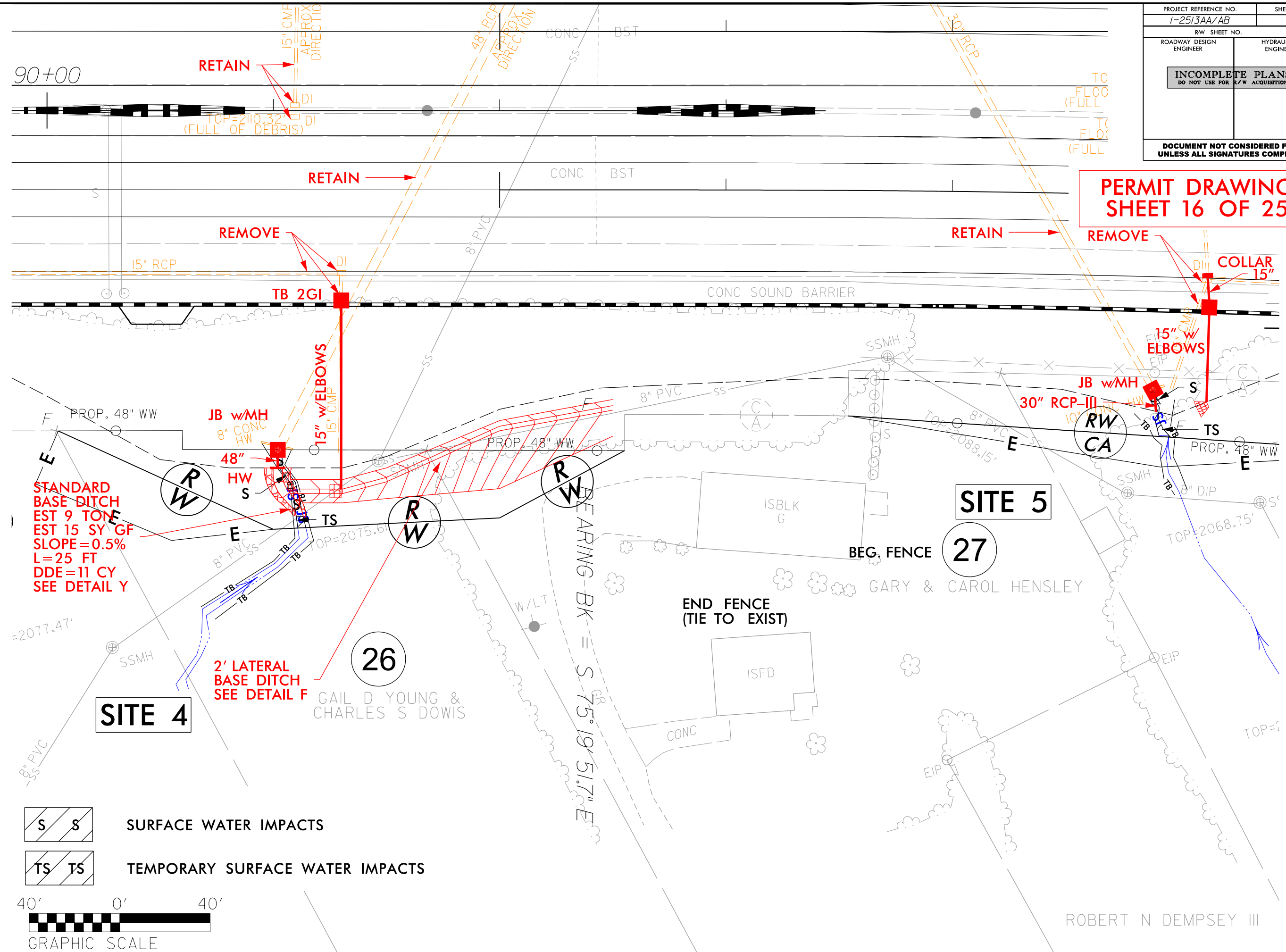

**STANDARD
BASE DITCH**
EST 9 TON
EST 15 SY GF
SLOPE = 0.5%
L = 25 FT
DDE = 11 CY
SEE DETAIL Y

**2' LATERAL
BASE DITCH**
SEE DETAIL F

- S S SURFACE WATER IMPACTS
- TS TS TEMPORARY SURFACE WATER IMPACTS

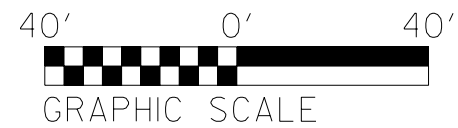



ROBERT N DEMPSEY III



8/17/99
 REVISIONS
 10/30/2022
 C:\pwworking\eeecom_ds21_na_2020\40244737\12513AA_hyd_prm_psh_09E_inlet.dgn

5/14/99

**PERMIT DRAWING
SHEET 18 OF 25**

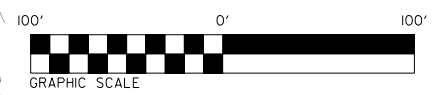
PROJECT REFERENCE NO. 1-2513AA/AB	SHEET NO. 9
RW SHEET NO.	
ROADWAY DESIGN ENGINEER	HYDRAULICS ENGINEER
INCOMPLETE PLANS DO NOT USE FOR R/W ACQUISITION	
DOCUMENT NOT CONSIDERED FINAL UNLESS ALL SIGNATURES COMPLETED	
 KCI	KCI ASSOCIATES OF N.C., P.A. 4505 Falls of Neuse Road, Suite 400 Raleigh, NC 27609-6270 Phone (919) 783-0214 NC Firm License No. C-0764
 ETHERHILL ENGINEERING	1223 Jones Franklin Rd. Raleigh, N.C. 27606 License No. F-43377 Bus: 919 851 9077 Fax: 919 851 8107
TRANSPORTATION PLANNING/DESIGN - BRIDGE/STRUCTURE DESIGN CIVIL/SITE DESIGN - GIS/GIS/PS - CONSTRUCTION OBSERVATION	



-  SURFACE WATER IMPACTS
-  TEMPORARY SURFACE WATER IMPACTS

MATCHLINE -Y- STA 88+00 - SEE SHEET 8

MATCHLINE -Y_WB- STA 18+50 - SEE SHEET 10

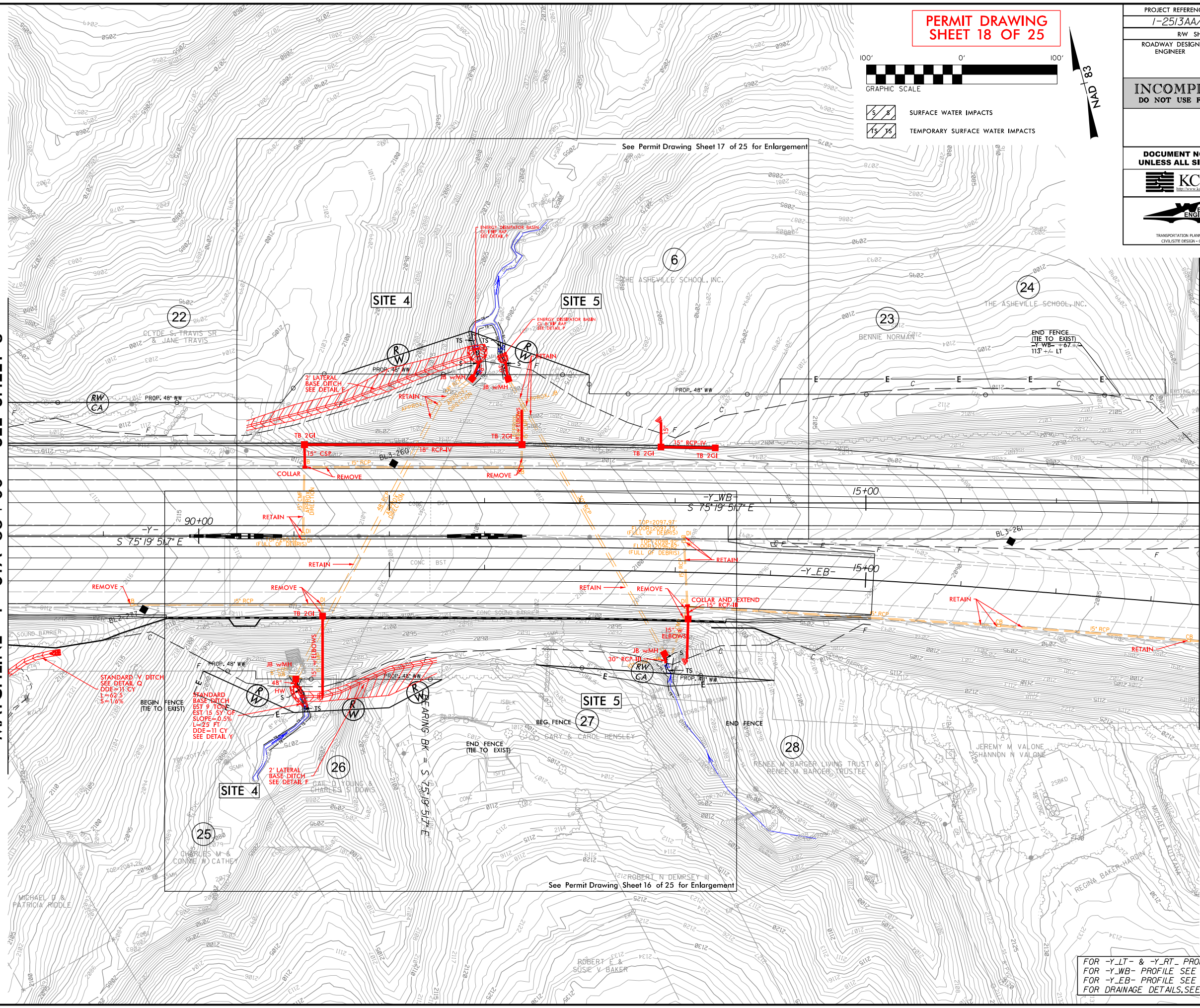

REVISIONS

10/30/2020
\\sccom-ds-01\10302020\12513AA\hyd.prm.psh.09.con.dgn

FOR -Y_LT- & -Y_RT- PROFILES SEE SHEET 20
 FOR -Y_WB- PROFILE SEE SHEET 21
 FOR -Y_EB- PROFILE SEE SHEET 21
 FOR DRAINAGE DETAILS, SEE SHEET 20-1

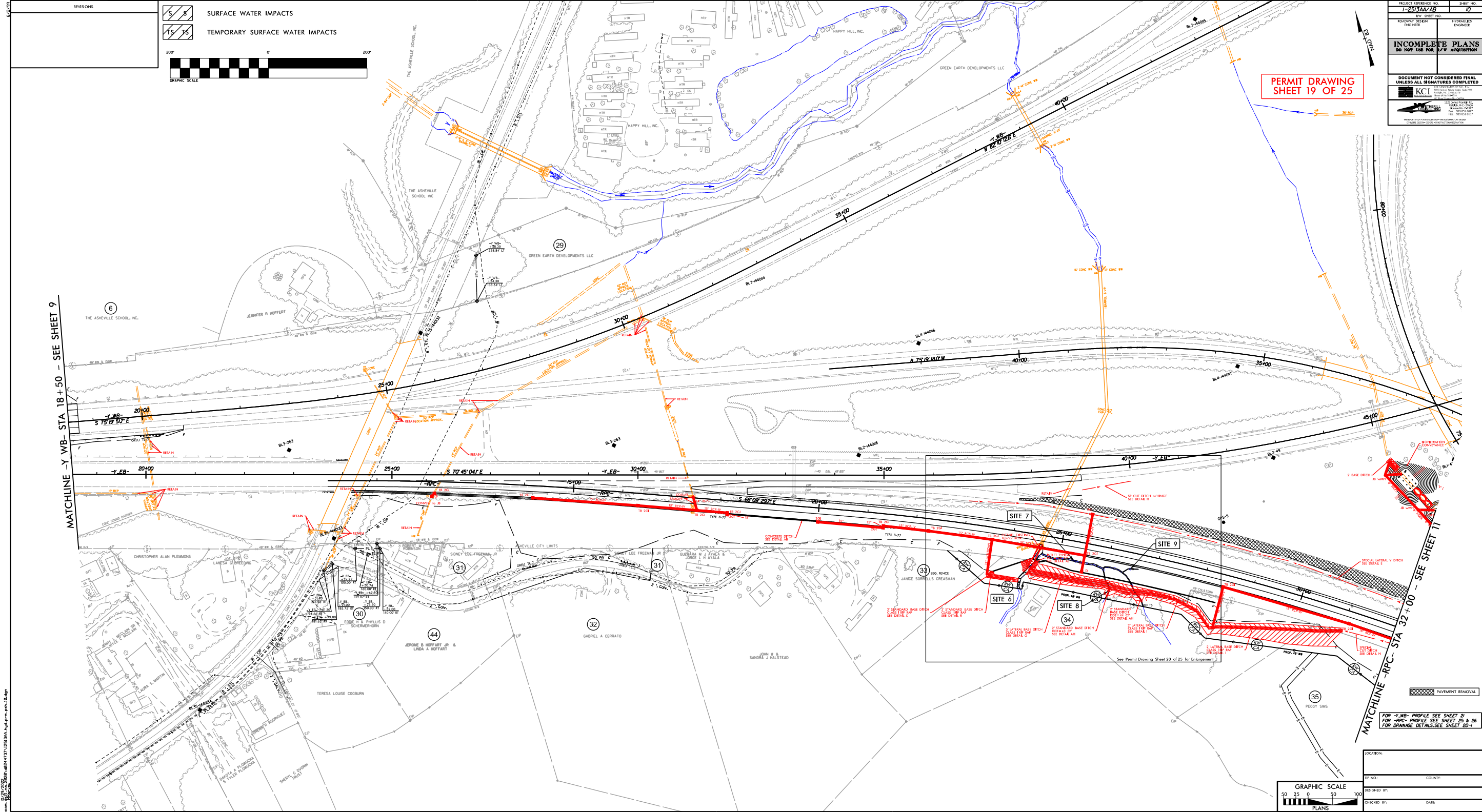

REVISIONS	
1	
2	
3	
4	
5	
6	
7	
8	
9	
10	
11	
12	
13	
14	
15	
16	
17	
18	
19	
20	
21	
22	
23	
24	
25	

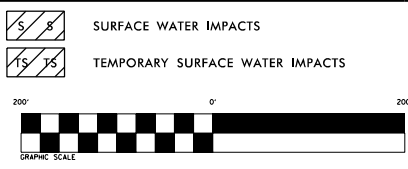

**PERMIT DRAWING
SHEET 19 OF 25**

PROJECT REFERENCE NO. 7-25144/AR	SHEET NO. 19
ROADWAY DESIGN ENGINEER	HYDRAULIC ENGINEER
INCOMPLETE PLANS DO NOT USE FOR R/W ACQUISITION	
DOCUMENT NOT CONSIDERED FINAL UNLESS ALL SIGNATURES COMPLETED	
<small> KCI CONSULTANTS, INC. 101 SOUTH BROADWAY, SUITE 100 ASHEVILLE, NC 28801 PHONE: 828.252.1000 FAX: 828.252.1001 WWW.KCI-CONSULTANTS.COM </small>	

MATCHLINE -Y WB- STA 18+50 - SEE SHEET 9

MATCHLINE -RPC- STA 32+00 - SEE SHEET 11

FOR -Y WB- PROFILE SEE SHEET 20
FOR -RPC- PROFILE SEE SHEET 25 & 26
FOR DRAINAGE DETAILS SEE SHEET 20-1

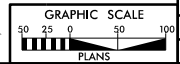

LOCATION:	
TP NO.:	COUNTY:
DESIGNED BY:	CHECKED BY:
DATE:	

C:\Users\jmc\Documents\7-25144\7-25144-19.dwg

PROJECT REFERENCE NO. I-25/3AA/AB	SHEET NO.
ROADWAY DESIGN ENGINEER	HYDRAULICS ENGINEER
INCOMPLETE PLANS DO NOT USE FOR R/W ACQUISITION	
DOCUMENT NOT CONSIDERED FINAL UNLESS ALL SIGNATURES COMPLETED	

SITE 6

-RPC- 24+50

PERMIT DRAWING
SHEET 22 OF 25

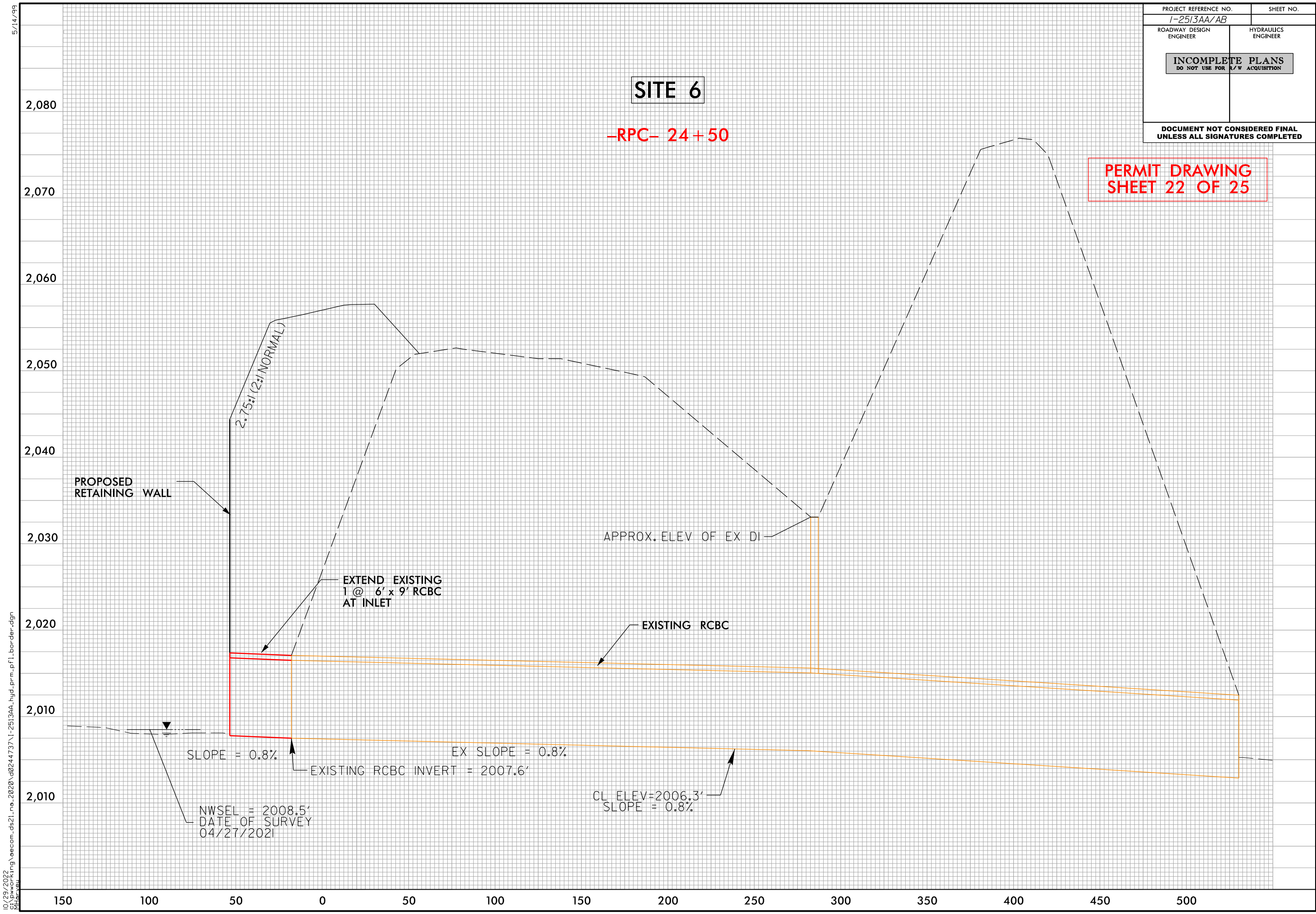

5/14/99
 10/29/2022
 S:\working\oeocom.ds21.no.2020\024737\I-25/3AA_hyd_perm.pfl_border.dgn

5/14/99
10/23/2022
ng\secom...d0244737\12513AA_hyd_prm_psh_12.dgn

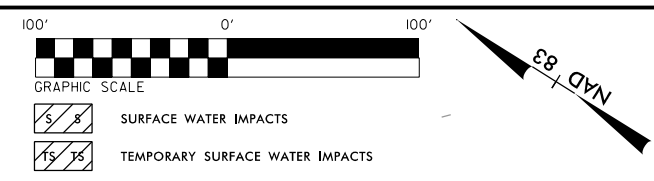

PROJECT REFERENCE NO. 1-2513AA/AB	SHEET NO. 12
R/W SHEET NO.	
ROADWAY DESIGN ENGINEER	HYDRAULICS ENGINEER
INCOMPLETE PLANS DO NOT USE FOR R/W ACQUISITION	
DOCUMENT NOT CONSIDERED FINAL UNLESS ALL SIGNATURES COMPLETED	
	KCI ASSOCIATES OF N.C., P.A. 4505 Falls of Neuse Road, Suite 400 Raleigh, NC 27609-4270 Phone (919) 783-9214 NC Firm License No. C-0764
	1223 Jones Franklin Rd. Raleigh, N.C. 27606 License No. F-43377 Bus: 919 851 9077 Fax: 919 851 8107
TRANSPORTATION PLANNING/DESIGN - BRIDGE/STRUCTURE DESIGN CIVIL/SITE DESIGN - GIS/GIS - CONSTRUCTION OBSERVATION	

**PERMIT DRAWING
SHEET 23 OF 25**

MATCHLINE -LI WB- STA 64+50
SEE SHEET 11

MATCHLINE -LI EB- STA 64+00
SEE SHEET 11

MATCHLINE -RPC- STA 41+85
SEE SHEET 11

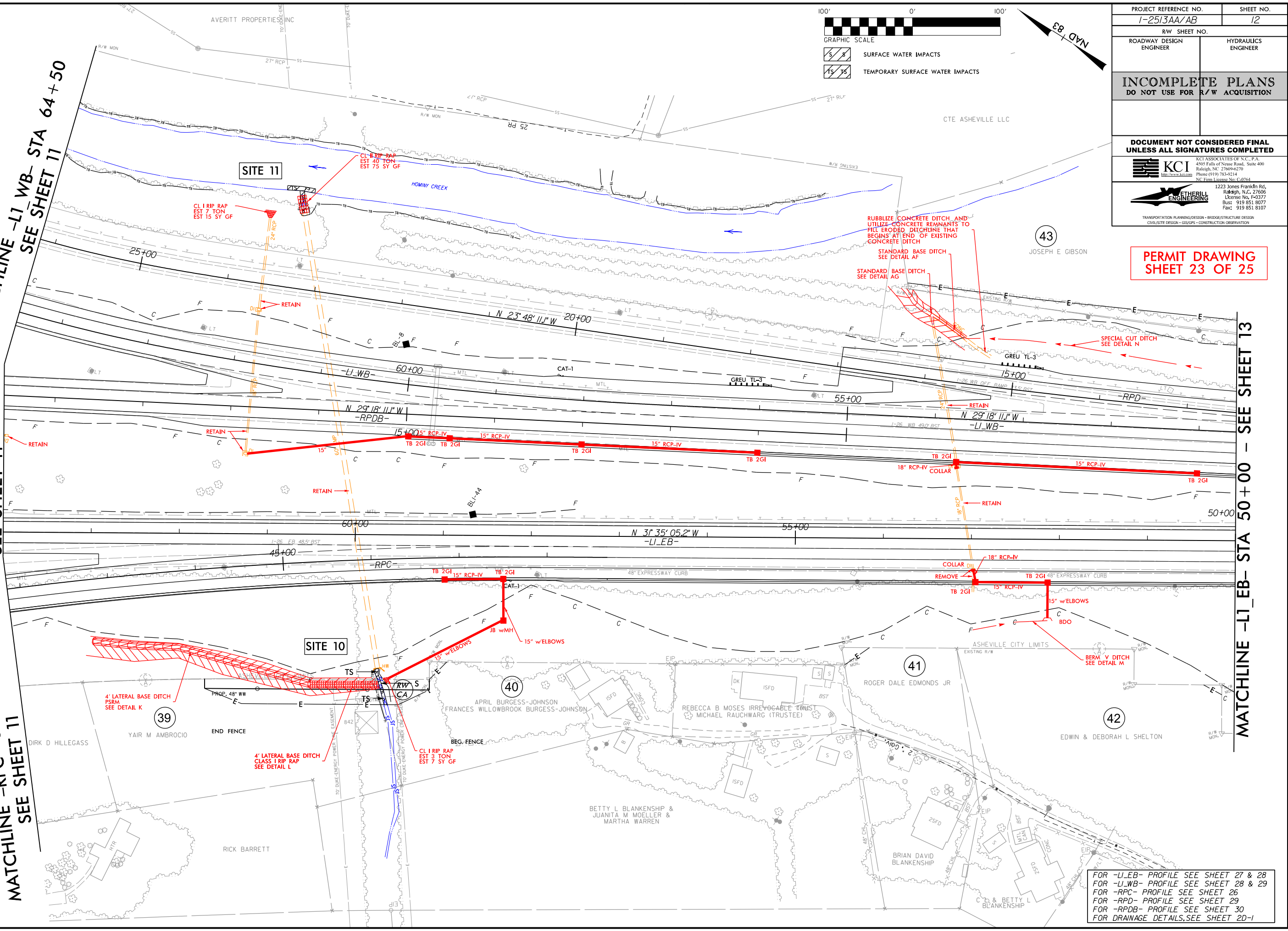

MATCHLINE -LI EB- STA 50+00
SEE SHEET 13





FOR -LI EB- PROFILE SEE SHEET 27 & 28
FOR -LI WB- PROFILE SEE SHEET 28 & 29
FOR -RPC- PROFILE SEE SHEET 26
FOR -RPD- PROFILE SEE SHEET 29
FOR -RPDB- PROFILE SEE SHEET 30
FOR DRAINAGE DETAILS, SEE SHEET 2D-1

5/14/99

GRAPHIC SCALE
 100' 0' 100'

 SURFACE WATER IMPACTS
 TEMPORARY SURFACE WATER IMPACTS

PROJECT REFERENCE NO. I-25/3AA/AB	SHEET NO. 12
ROADWAY DESIGN ENGINEER	HYDRAULICS ENGINEER
INCOMPLETE PLANS DO NOT USE FOR R/W ACQUISITION	
DOCUMENT NOT CONSIDERED FINAL UNLESS ALL SIGNATURES COMPLETED	
 KCI ASSOCIATES OF N.C., P.A. 4505 Falls of Neuse Road, Suite 400 Raleigh, NC 27609-4270 Phone (919) 783-9214 NC Firm License No. C-0764	 1223 Jones Franklin Rd. Raleigh, N.C. 27606 License No. F-43377 Bus: 919 851 9077 Fax: 919 851 8107 TRANSPORTATION PLANNING/DESIGN - BRIDGE/STRUCTURE DESIGN CIVIL/SITE DESIGN - GIS/GPS - CONSTRUCTION OBSERVATION

PERMIT DRAWING
SHEET 24 OF 25

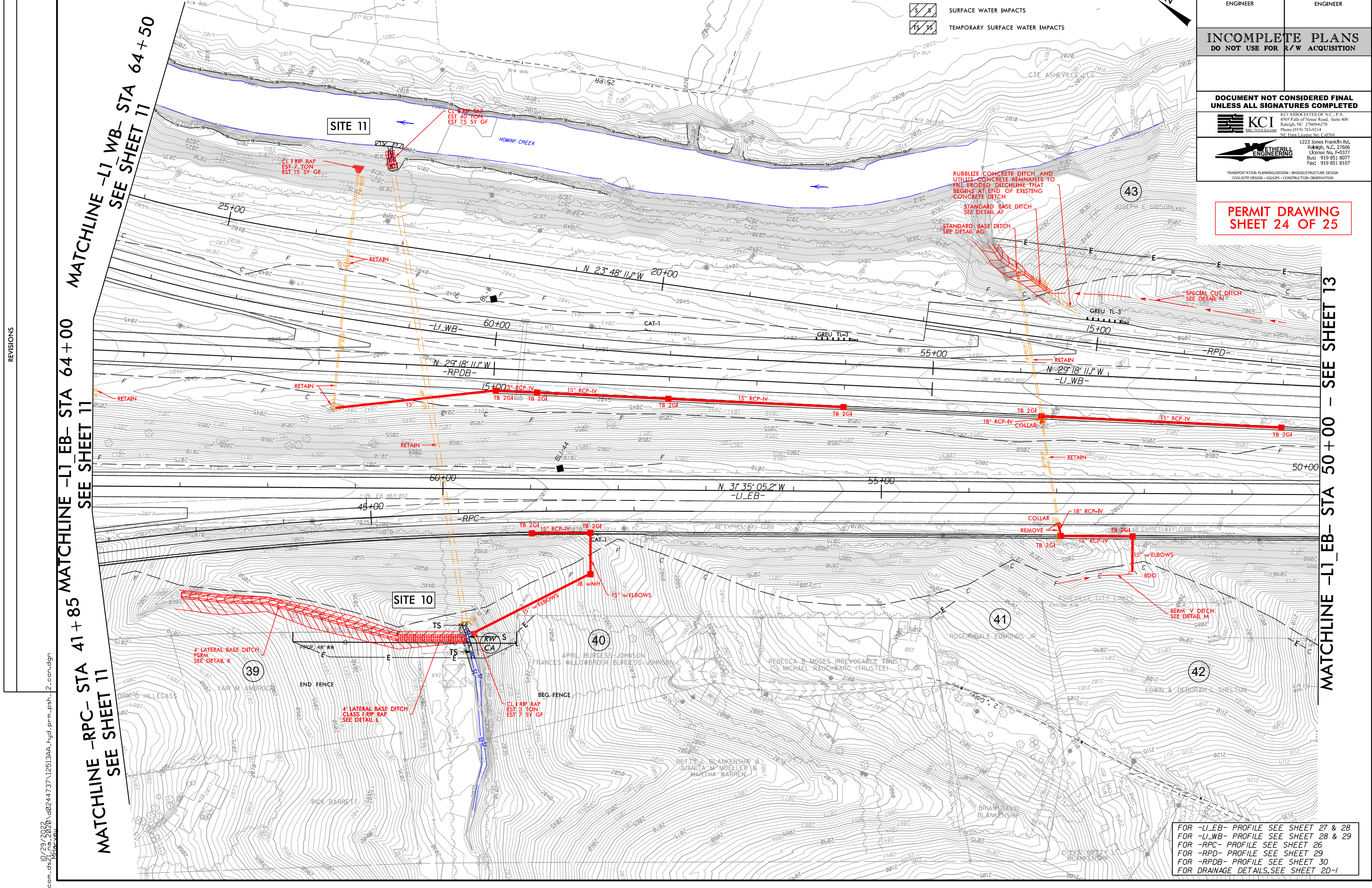

FOR -LI.EB- PROFILE SEE SHEET 27 & 28
 FOR -LI.WB- PROFILE SEE SHEET 28 & 29
 FOR -RPC- PROFILE SEE SHEET 26
 FOR -RPD- PROFILE SEE SHEET 29
 FOR -RPDB- PROFILE SEE SHEET 30
 FOR DRAINAGE DETAILS, SEE SHEET 2D-1

REVISIONS

\\aecm.cdi\012372020\d0244737\I25\3AA_hyd_perm_psh_2_con.dgn

MATCHLINE -LI.EB- STA 64+00
SEE SHEET 11

MATCHLINE -LI.WB- STA 64+50
SEE SHEET 11

MATCHLINE -RPC- STA 41+85
SEE SHEET 11

MATCHLINE -RPC- STA 41+85
SEE SHEET 11

MATCHLINE -LI.EB- STA 50+00 - SEE SHEET 13

WETLAND AND SURFACE WATER IMPACTS SUMMARY

Site No.	Station (From/To)	Structure Size / Type	WETLAND IMPACTS					SURFACE WATER IMPACTS					
			Permanent Fill In Wetlands (ac)	Temp. Fill In Wetlands (ac)	Excavation in Wetlands (ac)	Mechanized Clearing in Wetlands (ac)	Hand Clearing in Wetlands (ac)	Permanent SW impacts (ac)	Temp. SW impacts (ac)	Existing Channel Impacts Permanent (ft)	Existing Channel Impacts Temp. (ft)	Natural Stream Design (ft)	
1	-Y- 50+95 Rt	Existing 48" Pipe							< 0.01		11		
	-Y- 50+95 Rt	Base Ditch							< 0.01	< 0.01	39	15	
2	-Y- 59+50 Lt	3@7x9 RCBC Extention							0.04		147		
	-Y- 58+70 Lt	84"CMP							0.02	< 0.01	44	10	
3	-Y- 69+85 Lt / -Y- 72+95 Rt	Channel Relocation	< 0.01		< 0.01			< 0.01	0.02	< 0.01	89	17	
4	-Y- 91+05 Rt	Channel Relocation							< 0.01	< 0.01	24	5	
	-Y- 91+05 Rt	48" Pipe							< 0.01		8		
	-Y- 92+92 Lt	48" Pipe							0.01		19		
	-Y- 92+92 Lt	Energy Dissipator							0.01	< 0.01	19	14	
5	-Y- 93+44 Rt	30' Pipe							< 0.01	< 0.01	10	11	
	-Y- 93+20 Lt	30' Pipe							< 0.01		17		
	-Y- 93+20 Lt	Energy Dissipator							< 0.01	< 0.01	10	12	
6	-RPC- 24+24 to 26+90 Rt	1@6'X9' RCBC Extension							< 0.01	< 0.01	58	8	
	-RPC- 24+24 to 26+90 Rt	Bank Stabilization							< 0.01		40		
7	-RPC- 25+50 Rt	Base Ditch							0.01	< 0.01	246	9	
8	-RPC- 26+05 Rt	Base Ditch							< 0.01	< 0.01	60	5	
9	-RPC- 26+50 Rt	Base Ditch							< 0.01		34	9	
10	-RPC- 46+05 Rt	Base Ditch							< 0.01	< 0.01	19	24	
11	-RPD- 23+30 Rt	Outfall Protection							< 0.01	< 0.01		32	
TOTALS*:			< 0.01		< 0.01			< 0.01	0.14	0.02	894	171	0

*Rounded totals are sum of actual impacts

NOTES:

NC DEPARTMENT OF TRANSPORTATION
 DIVISION OF HIGHWAYS
 10/31/2022
 Buncombe County
 I-2513 AA/AB
 34165.1.11/34165.1.12
 SHEET 25 OF 25