

18 CHANNEL IP CONFLICT MONITOR PROGRAMMING DETAIL

(remove jumpers and set switches as shown)

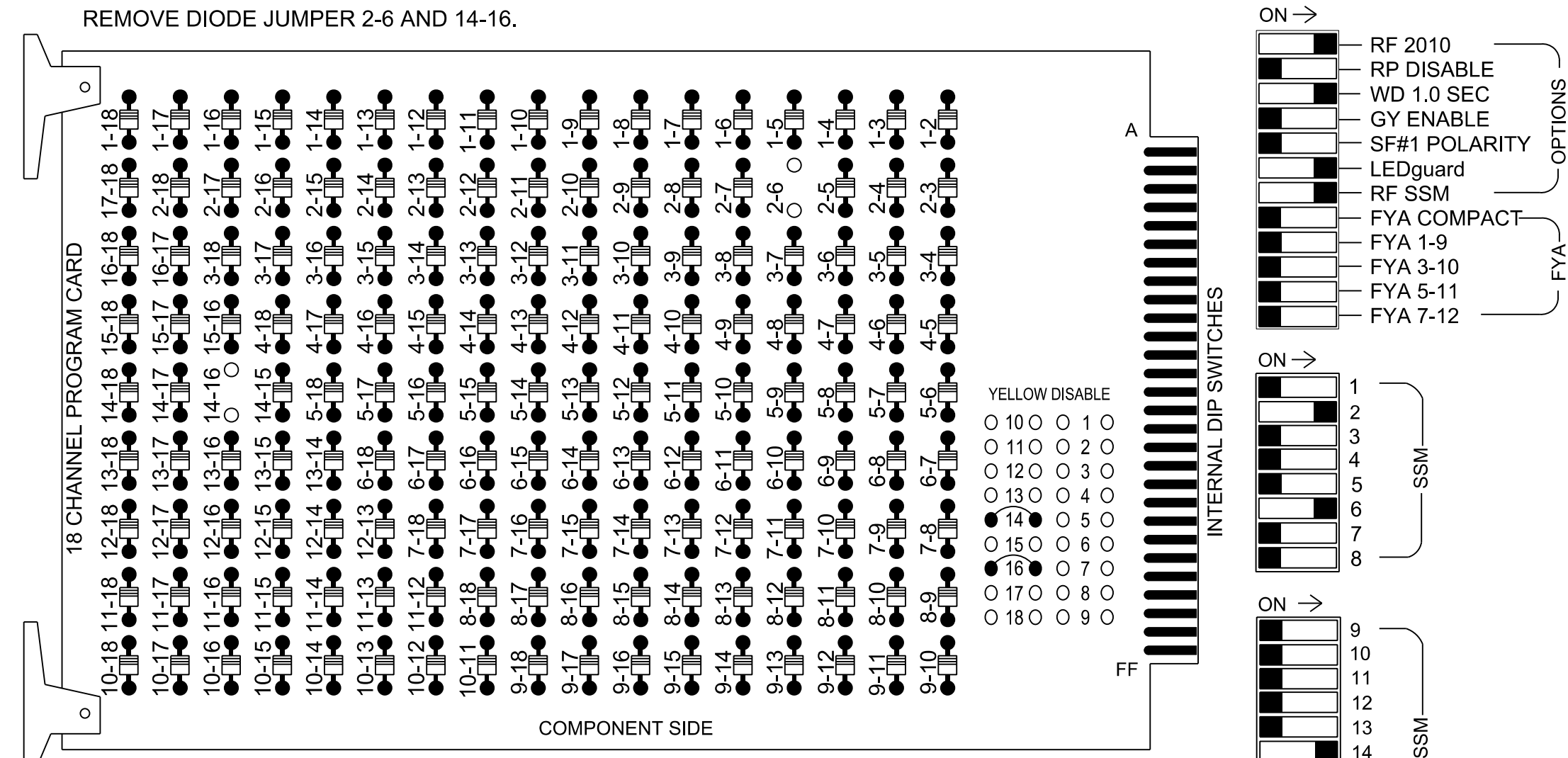

- NOTES:**
- Card is provided with all diode jumpers in place. Removal of any jumper allows its channels to run concurrently.
 - Ensure jumpers SEL2-SEL5 and SEL9 are present on the monitor board.
 - Ensure that the Red Enable is active at all times during normal operation.
 - Integrate monitor with Ethernet network in cabinet.

NOTES

- To prevent "flash-conflict" problems, insert red flash program blocks for all unused vehicle load switches in the output file. The installer shall verify that signal heads flash in accordance with the signal plan.
- Program controller to start up in phase 2 Green No Walk and 6 Green No Walk.
- Install the latest 332_NCDOT_HAWK_Default database onto controller.
- Program phases 4 and 8 No Startup Veh Call and No Startup Ped Call.
- Program phases 4 and 8 for Ped Clear during Red Clear.
- The cabinet and controller are part of the Belmont Signal System.

EQUIPMENT INFORMATION

Controller.....2070LX
 Cabinet.....332
 Software.....Q-Free MAXTIME
 Cabinet Mount.....Base
 Output File Positions.....12
 Load Switches Used.....S2, S6, S8, S12
 Phases Used.....2, 4*, 4 PED, 6, 8*, 8 PED
 Overlap "1".....NOT USED
 Overlap "2".....NOT USED
 Overlap "3".....NOT USED
 Overlap "4".....NOT USED

* Used for timing purposes only.

SIGNAL HEAD HOOK-UP CHART

LOAD SWITCH NO.	S1	S2	S3	S4	S5	S6	S7	S8	S9	S10	S11	S12
CMU CHANNEL NO.	1	2	13	3	4	14	5	6	15	7	8	16
PHASE	1	2	2 PED	3	4	4 PED	5	6	6 PED	7	8	8 PED
SIGNAL HEAD NO.	NU	21,22,23	NU	NU	NC	P41	NU	21,22,23	NU	NU	NC	P81
RED		128						134				
YELLOW		129						*				
GREEN		*						*				
RED ARROW												
YELLOW ARROW												
FLASHING YELLOW ARROW												
GREEN ARROW												
Hand						104						110
Walking Person						106						112

NU = Not Used
 NC = Not Connected
 * Denotes install load resistor. See load resistor installation detail this sheet.

INPUT FILE POSITION LAYOUT

(front view)

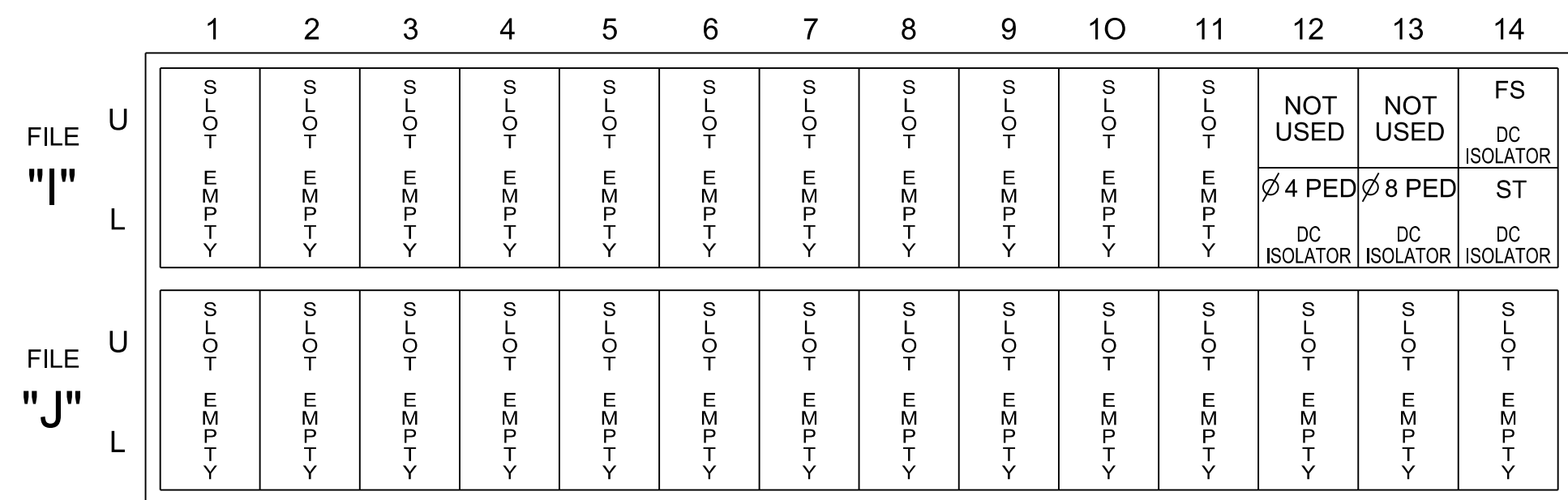

EX.: 1A, 2A, ETC. = LOOP NO.'S
 FS = FLASH SENSE
 ST = STOP TIME

INPUT FILE CONNECTION & PROGRAMMING CHART

LOOP NO.	LOOP TERMINAL	INPUT FILE POS.	PIN NO.	INPUT POINT	DETECTOR NO.	CALL PHASE	DELAY TIME	EXTEND TIME	EXTEND	ADDED INITIAL	CALL	DELAY DURING GREEN
P41	TB8-5,6	I12L	69	35	4	PED 4 / 8 *						
P81	TB8-8,9	I13L	70	36	8	PED 8 / 4 *						

* FOR THE ABOVE DETECTORS TO CALL ANOTHER PHASE SCROLL OVER AND ENTER SECOND PHASE IN "ADDITIONAL CALL PHASES" COLUMN.

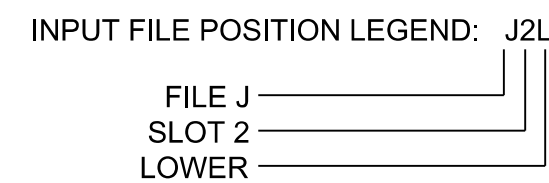

OPERATIONAL NOTES

- In order for the controller to perform the Pedestrian Hybrid Beacon (HAWK signal) sequence, the 332_NCDOT_HAWK_v1_3 database must be installed on the controller.
- The only Phase 6 load switch output that is being used drives one of the red signal faces of each signal head.
- The Logic Processor flashes Phase 2 Yellow during the Phase 2 Pre-Clearance Interval. Phase 2 Yellow drives the solid yellow signal face during the Phase 2 Vehicle Yellow Change.
- The Phase 2 and Phase 6 Red outputs drives the solid Red displays during the Phase 2 and 6 Red Clear and Ped 4 and 8 Walk Interval. The Logic Processor flashes Phase 2 and Phase 6 Red Outputs in a wig-wag pattern during 4+8 Ped Clear Interval.
- The controller must be programmed for Ped Clear During Red Clear for Pedestrian Phases 4 and 8 so that Red displays continue to flash during Phases 4 and 8 Yellow Change and Red Clear.
- Make sure that all Phase 2 and Phase 6 timings match each other and that all Phase 4 and Phase 8 timings match each other.
- The Ped 4 push button is programmed to call Ped 4 and Ped 8. The Ped 8 push button is programmed to call Ped 8 and Ped 4.

SIGNAL HEAD WIRING DETAIL

(wire signal heads as shown)

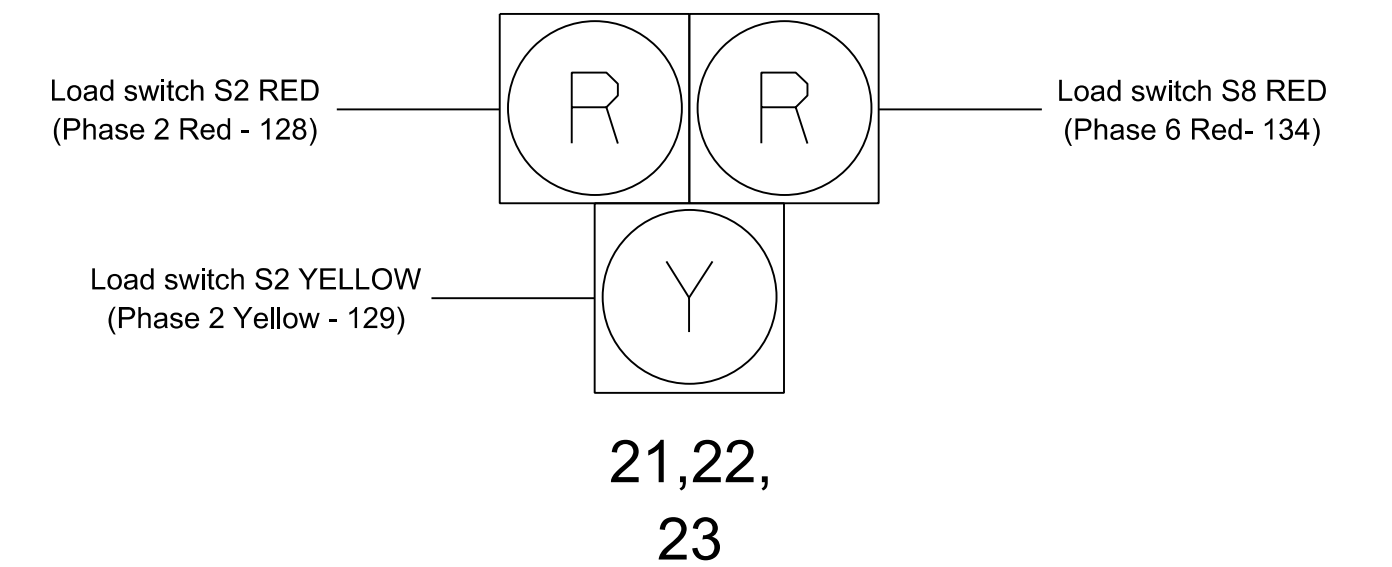

TIMING INTERVAL

PHASE 2+6 = DARK DISPLAY
 PHASE 2+6 PRE CLEARANCE = FLASHING YELLOW DISPLAY
 PHASE 2+6 YELLOW CHANGE = STEADY YELLOW DISPLAY
 PHASE 2+6 RED CLEAR THROUGH 4+8 WALK = STEADY RED DISPLAY
 PED 4+8 DON'T WALK = ALTERNATING FLASHING RED DISPLAY

THIS ELECTRICAL DETAIL IS FOR THE SIGNAL DESIGN: 12-1921
 DESIGNED: August 2025
 SEALED: 8/1/2025
 REVISED: N/A

LOAD RESISTOR INSTALLATION DETAIL

(install resistors as shown)

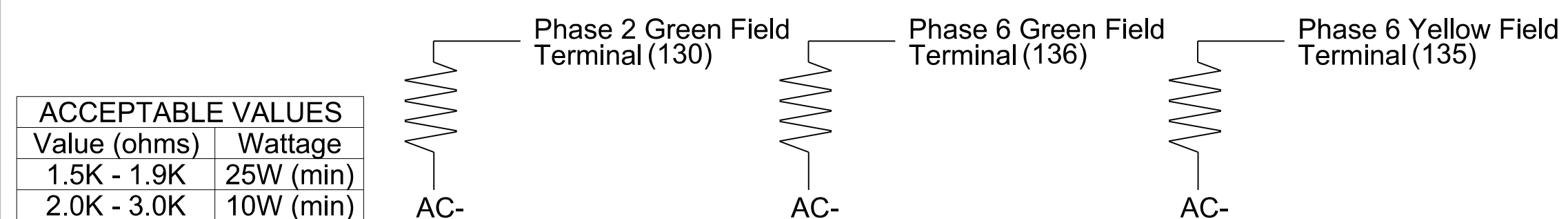

ACCEPTABLE VALUES	
Value (ohms)	Wattage
1.5K - 1.9K	25W (min)
2.0K - 3.0K	10W (min)

COUNTDOWN PEDESTRIAN SIGNAL OPERATION

Countdown Ped Signals are required to display timing only during Ped Clearance Interval. Consult Ped Signal Module user's manual for instructions on selecting this feature.

New Installation - Electrical Detail

Electrical and Programming Details For: Pedestrian Hybrid Beacon: US 29-74 (Wilkinson Blvd) at Eastbound U-Turn Bulb West of Catawba River Bridge

Division 12 Gaston County Belmont

PLAN DATE: August 2025 REVIEWED BY: CB Holden

PREPARED BY: WP Erickson-Jones REVIEWED BY: DT Sears

REVISIONS: INIT. DATE

750 N. Greenfield Pkwy, Garner, NC 27529

DOCUMENT NOT CONSIDERED FINAL UNLESS ALL SIGNATURES COMPLETED

SEAL NORTH CAROLINA PROFESSIONAL ENGINEER DAVID T. SEARS 044558

Designed by: David T. Sears 8/1/2025

SIG. INVENTORY NO. 12-1921