

CONCRETE SHAFT ELEVATION

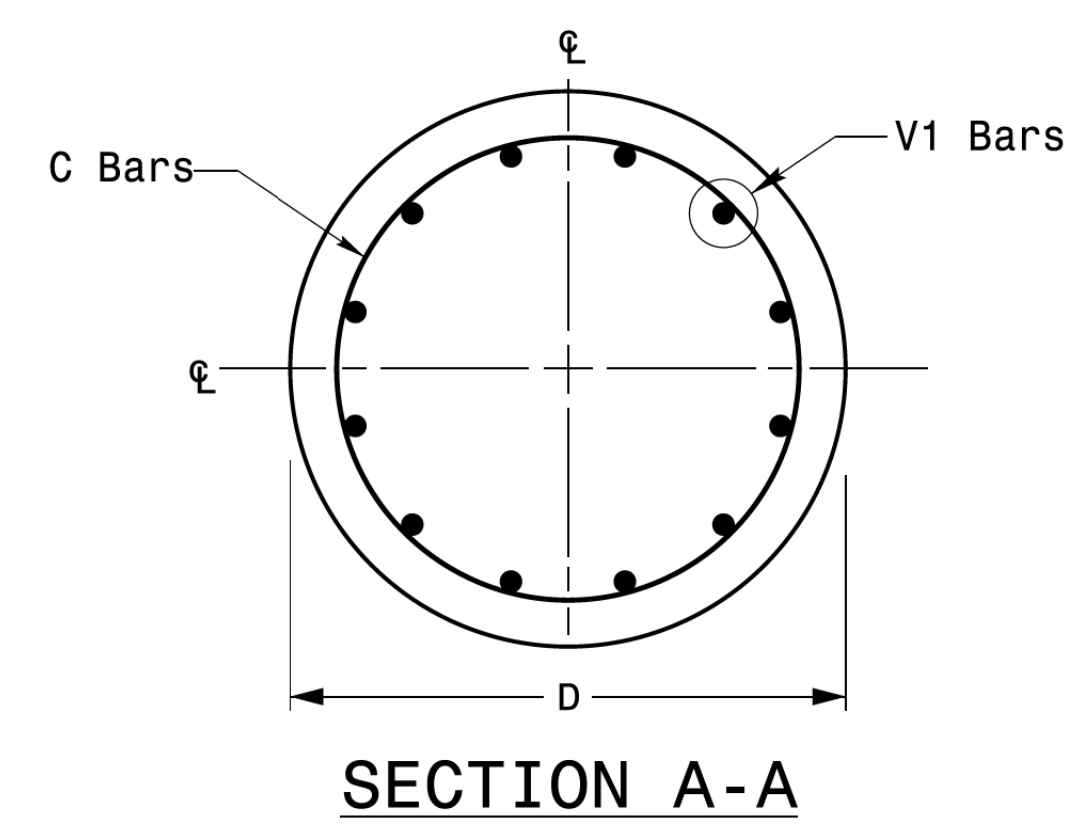

SECTION A-A

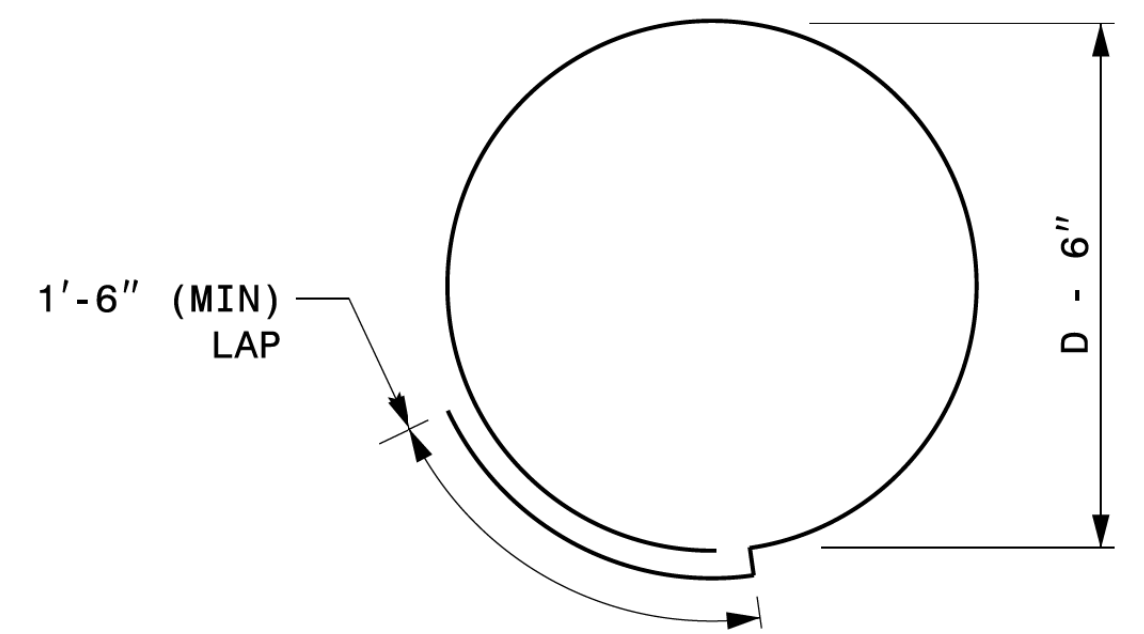

TYPICAL "C" BAR DETAIL

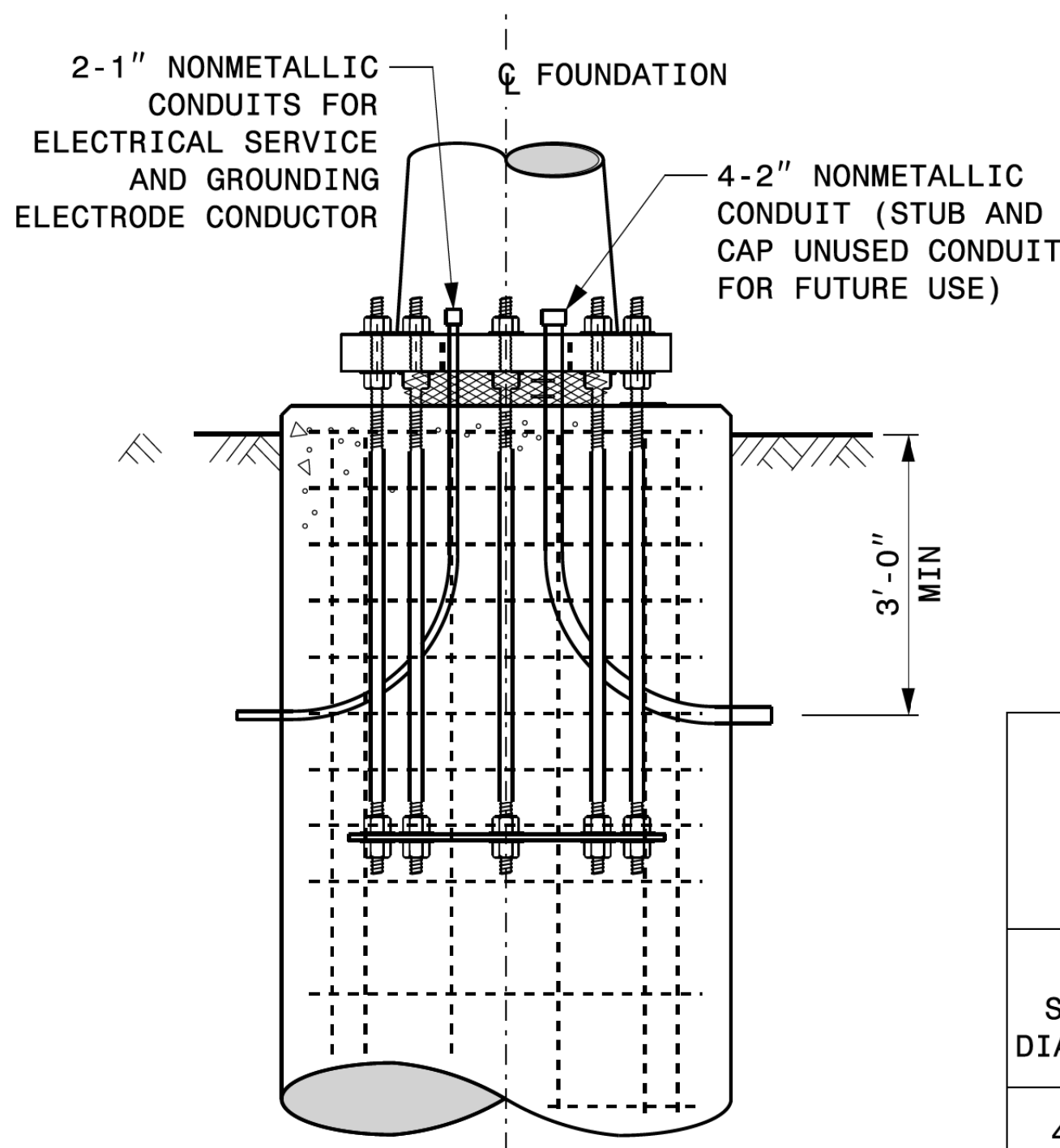

TYPICAL FOUNDATION CONDUIT DETAILS

GENERAL NOTES:

- IF ACTUAL SUBSURFACE CONDITIONS DIFFER SIGNIFICANTLY FROM BORING DATA, CONTACT THE ENGINEER BEFORE EXCAVATING OR PLACING CONCRETE.
- CIRCULAR TIE REINFORCING RINGS MAY BE VERTICALLY ADJUSTED BY +/-3" AT A DEPTH BETWEEN 2'-0" AND 3'-0" TO FACILITATE THE INSTALLATION OF ELECTRICAL CONDUIT ENTERING IN THE CAGE.
- FOR STANDARD FOUNDATIONS, SEE SHEET SIG. M8 FOR DETAILS. VERTICAL REINFORCING BARS (V1) MAY BE HORIZONTALLY ADJUSTED BY +/-3" TO FACILITATE THE INSTALLATION OF ELECTRICAL CONDUIT ENTERING INTO THE CAGE.
- PROVIDE 2" TO 5" FOUNDATION PROJECTION ABOVE GROUND LEVEL, DEPENDING ON THE GROUND SLOPE.
- UNLESS OTHERWISE SHOWN, FOUNDATION DESIGNS ARE BASED ON NON-SLOPING LEVEL GROUND SURFACES WITH SLOPE RATIOS OF 8:1 (H:V) OR FLATTER. IF ACTUAL GROUND LINE SLOPES ARE STEEPER, CONTACT THE ENGINEER BEFORE EXCAVATING OR PLACING CONCRETE.
- CONSTRUCT FOUNDATIONS IN ACCORDANCE WITH NCDOT STANDARD PROVISIONS SP09 R005- FOUNDATIONS AND ANCHOR ROD ASSEMBLIES FOR METAL POLES. ALL APPLICABLE 2024 NCDOT STANDARD SPECIFICATIONS ARE REFERENCED IN THIS PROVISION. REFER TO THE NCDOT RESOURCES/SPECIFICATIONS PAGE LOCATED ON THE CONNECT NCDOT WEBSITE.
[https://connect.ncdot.gov/resources/Specifications and Special Provisions.aspx](https://connect.ncdot.gov/resources/Specifications%20and%20Special%20Provisions.aspx)
- USE AIR ENTRAINED AA CONCRETE MIX WITH A COMPRESSION STRENGTH OF f'c=4500 psi (MIN) AFTER 28 DAYS.
- USE ASTM A615 GRADE 60 DEFORMED BARS FOR ALL REINFORCING STEEL. MAINTAIN AT LEAST 3" COVER ON ALL REINFORCEMENT.
- LOCATE IDENTIFICATION TAG ON TOP OF THE FOUNDATION, DIRECTLY ABOVE THE CONDUIT'S ENTRY POINT.
- PROVIDE TWO LAYERS OF 4 MESH GALVANIZED WELDED 23 GAUGE (0.025) 6" WIDE AROUND PIPES UNDER THE BASE PLATE AND SECURE IT WITH TIES IF NECESSARY.
- PREFERRED LOCATION FOR THE I.D. TAG IS AS SHOWN IN DETAIL-A: DIRECTLY ABOVE THE CONDUIT ENTERING THE FOUNDATION.

REINFORCING STEEL TABLE FOR STANDARD DRILL PIER SHAFT (4'-0" DIAMETER)

"D" SHAFT DIAMETER	CONCRETE VOLUME (CU. YDS)	BAR NAME	MIN. SIZE	TYPE	LENGTH
4'-0"	.465 X L	V1	#8	STR.	**
		C	#4	CIR.	12'-6"

* SEE NOTE 2
 ** SEE NOTE 3

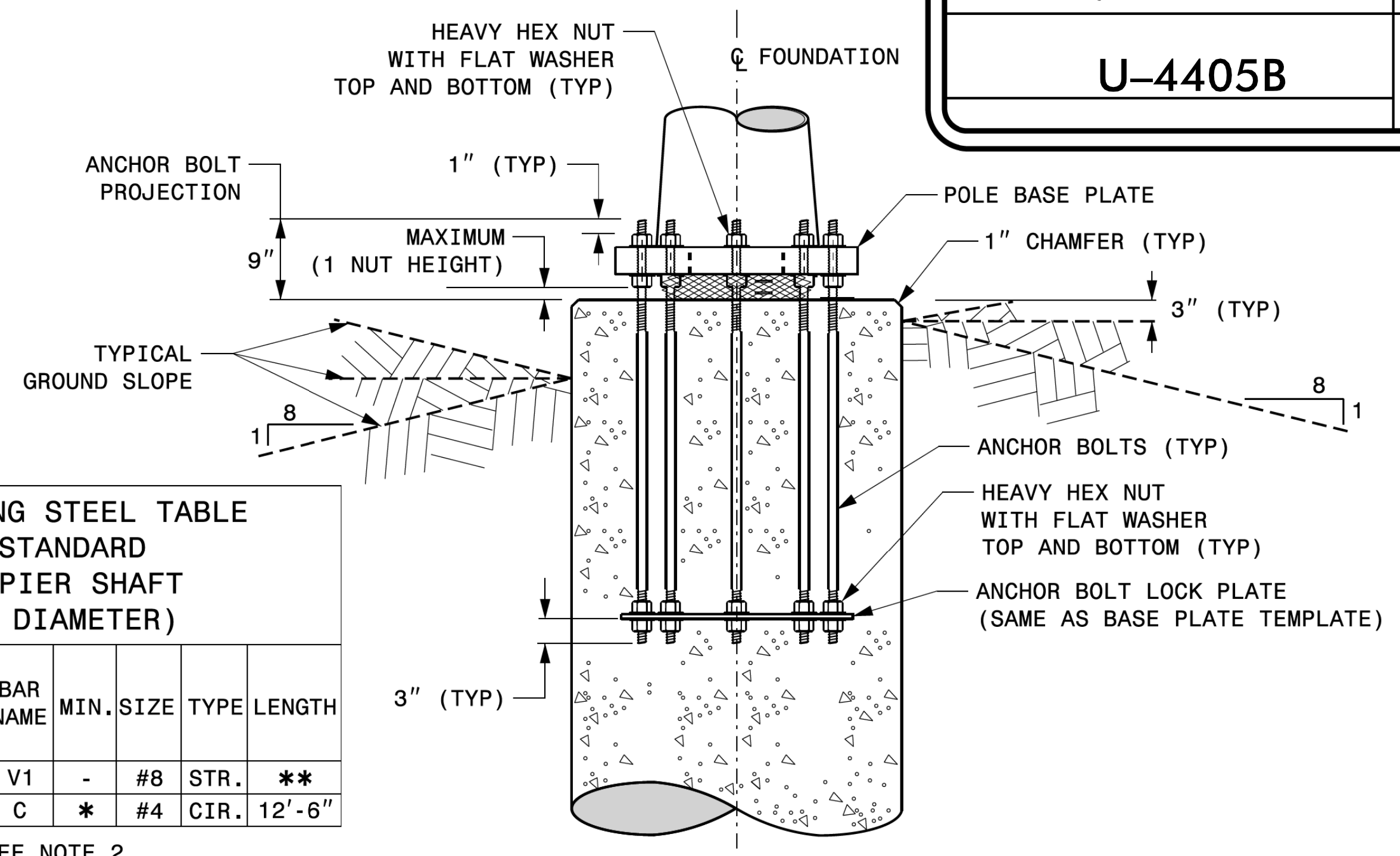

TYPICAL FOUNDATION ANCHOR BOLT DETAILS

(REINFORCING CAGE NOT SHOWN FOR CLARITY)

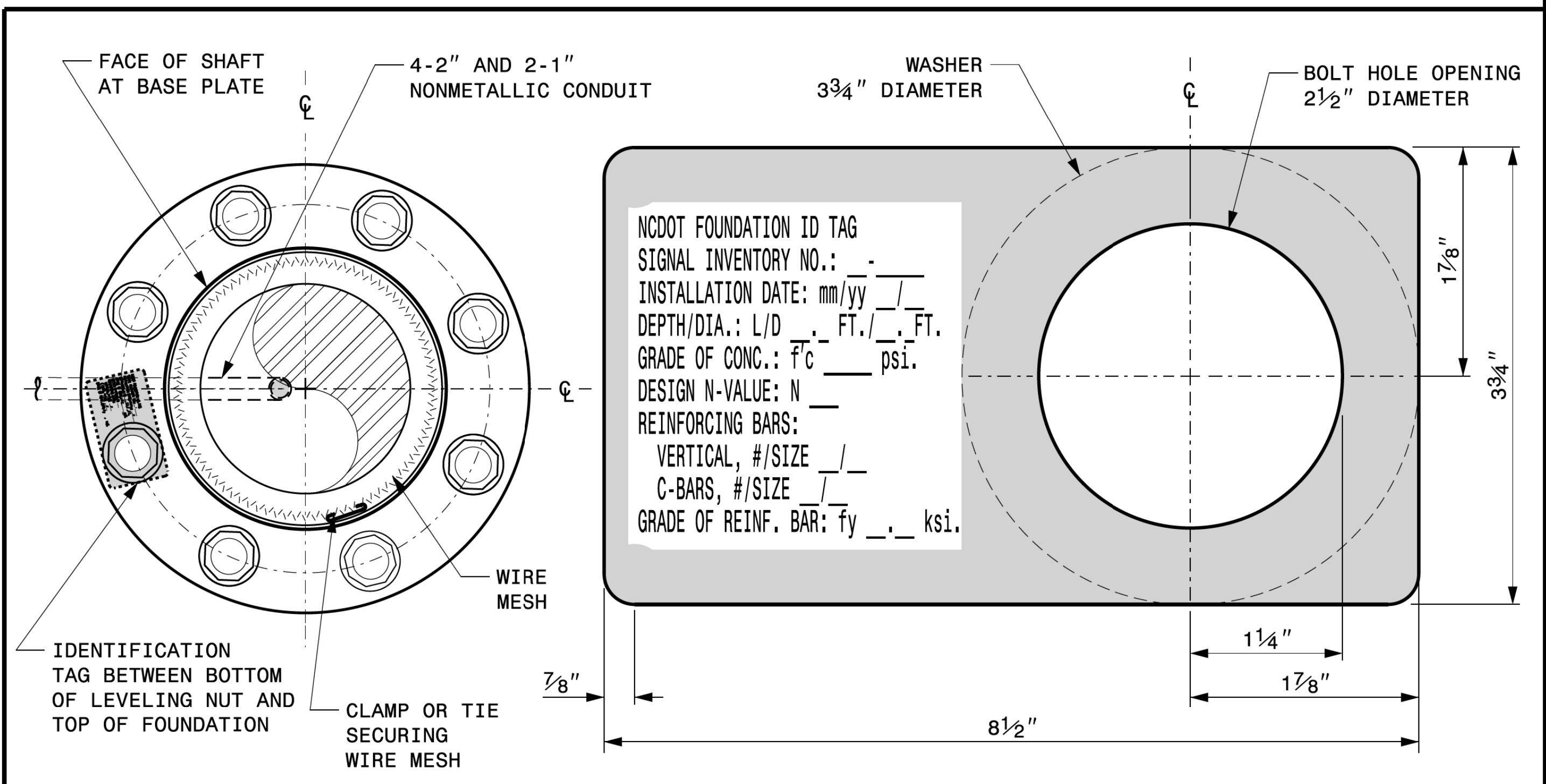

D = DIAMETER
 L = LENGTH / DEPTH
 mm = MONTH
 yy = YEAR

DETAIL - A

NCDOT FOUNDATION ID TAG
 SIGNAL INVENTORY NO.: -
 INSTALLATION DATE: mm/yy /
 DEPTH/DIA.: L/D . FT./ . FT.
 GRADE OF CONC.: f'c . psi.
 DESIGN N-VALUE: N
 REINFORCING BARS:
 VERTICAL, #/SIZE
 C-BARS, #/SIZE
 GRADE OF REINF. BAR: fy . ksi.

CONCRETE FOUNDATION IDENTIFICATION TAG DETAILS

Prepared in the Offices of:

Construction Details For Foundations

PLAN DATE: SEPTEMBER 2023 DESIGNED BY: K.C. DURIGON
 PREPARED BY: K.C. DURIGON REVIEWED BY: D.C. SARKAR

SCALE: NONE

DocuSigned by: Kevin Durigon
 4B23DC79B3784DA

09/21/2023

03-OCT-2023 12:45
 S:\Projects\2023\Signal\Drawings\Drawings\2024\Meta1 Pole 5td Drawings For URF02024_Sig.M7 Std. Construction Details-Strain Poles.dgn
 KCDURIGON

Construction Details - Foundations