

LANE TREATMENT

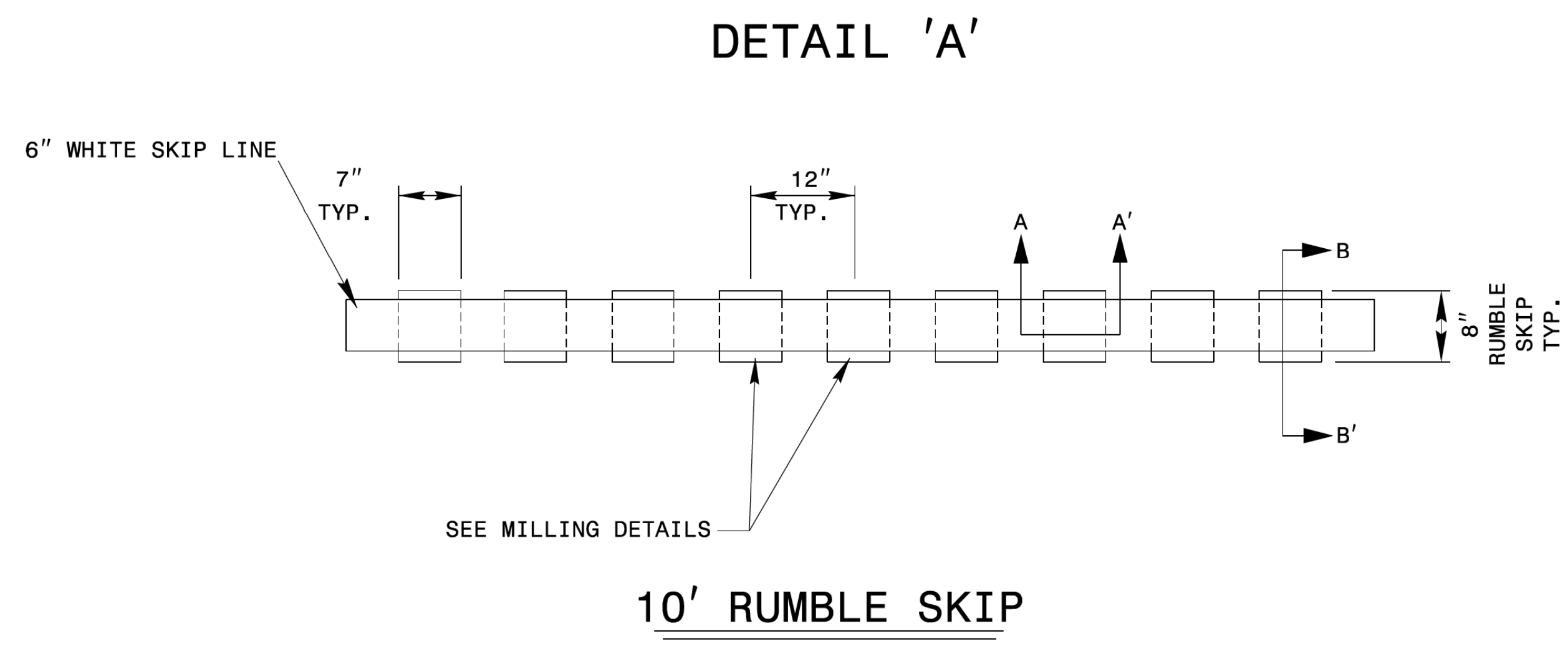

MILLING/MARKING DETAILS

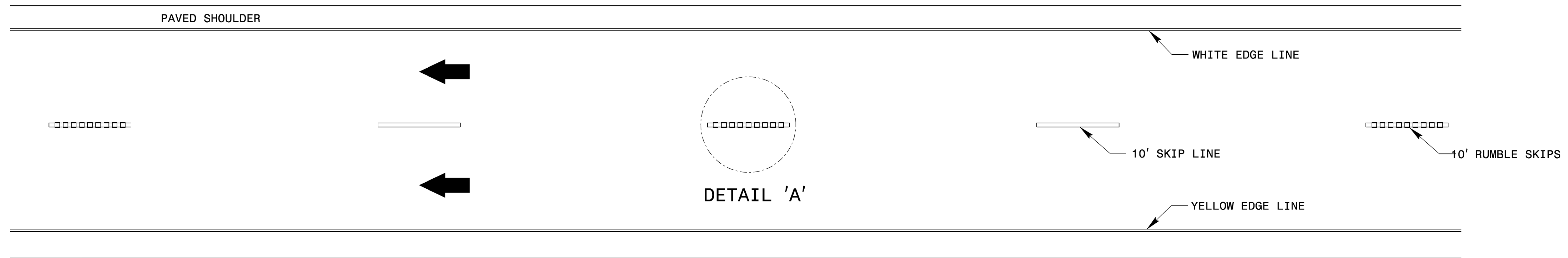
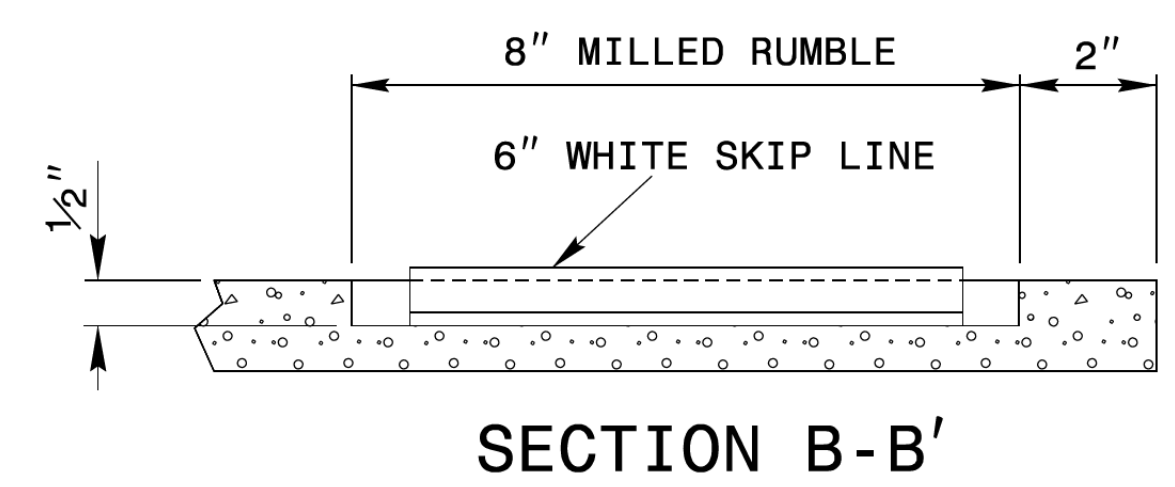
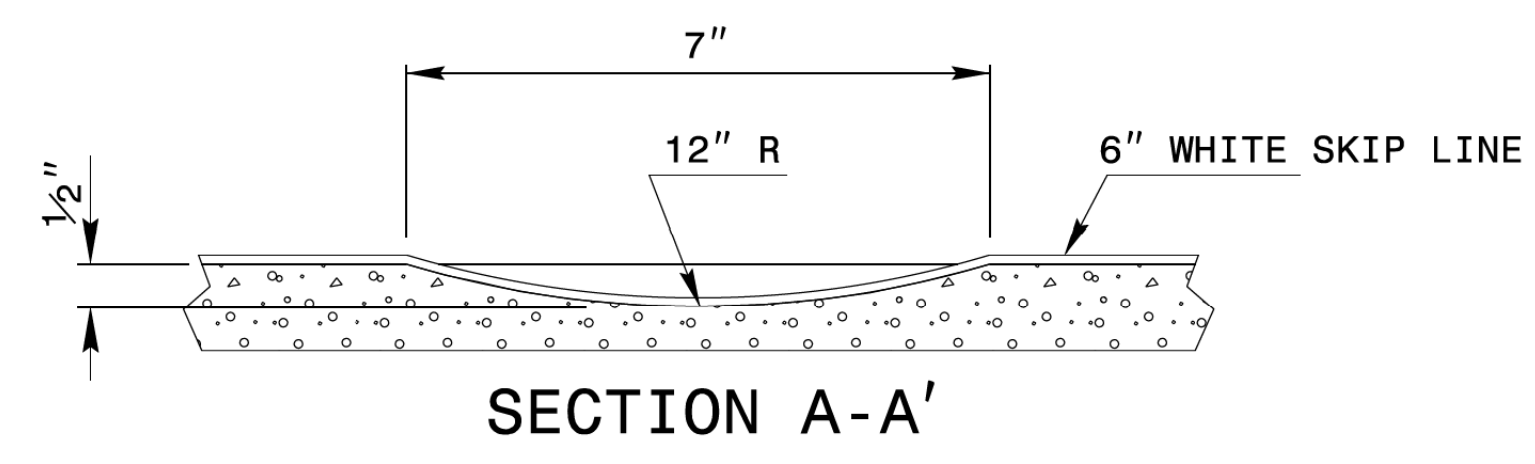

NOTES:

- 1) USING A VACUUM IN THE SAME OPERATION, REMOVE ALL DEBRIS FROM THE MILLINGS JUST PRIOR TO PLACING ANY PAVEMENT MARKINGS.
- 2) ENSURE GLASS BEADS ARE SPREAD UNIFORMLY OVER THE ENTIRE SURFACE OF PAVEMENT MARKING.
- 3) MILL RUMBLES EVERY OTHER SKIP AS SHOWN.
- 4) SEE PLANS FOR MARKING THICKNESS

CONTRACTS STANDARDS AND DEVELOPMENT UNIT
Office 919-707-8950 FAX 919-250-4119

DETAIL OF MILLED RUMBLE SKIPS

ORIGINAL BY: rgwatson DATE: 02-06-2024
 MODIFIED BY: DATE:
 CHECKED BY: DATE:
 FILE SPEC.: