

TIP NO. R-5930B	SHEET NO. PMP-1
APPROVED: _____	
DATE: _____	
SEAL	
	
<small>DocuSigned by: Vance W. Blanton 97AF92B55744EC</small>	
1/7/2025	
<b>DOCUMENT NOT CONSIDERED FINAL UNLESS ALL SIGNATURES COMPLETED</b>	

**STATE OF NORTH CAROLINA  
DEPARTMENT OF TRANSPORTATION**

**PAVEMENT MARKING PLAN  
CHATHAM COUNTY**

**LOCATION: CHATHAM PARK WAY FROM GRANT DRIVE TO US 15-501**

**TIP PROJECT: R-5930B**

**CONTRACT: C204933**

**ROADWAY STANDARD DRAWING**

THE FOLLOWING ROADWAY STANDARDS AS THEY APPEAR IN "ROADWAY STANDARD DRAWINGS" - PROJECT SERVICES UNIT - N.C. DEPARTMENT OF TRANSPORTATION - RALEIGH, N.C., DATED JANUARY 2018 ARE APPLICABLE TO THIS PROJECT AND BY REFERENCE HEREBY ARE CONSIDERED A PART OF THESE PLANS:

STD. NO.	TITLE
1205.01	PAVEMENT MARKINGS - LINE TYPES AND OFFSETS
1205.02	PAVEMENT MARKINGS - TWO-LANE AND MULTI-LANE ROADWAYS
1205.04	PAVEMENT MARKINGS - INTERSECTIONS
1205.05	PAVEMENT MARKINGS - TURN LANES
1205.07	PAVEMENT MARKINGS - PEDESTRIAN CROSSWALKS
1205.08	PAVEMENT MARKINGS - SYMBOLS AND WORD MESSAGES
1205.09	PAVEMENT MARKINGS - PAINTED ISLANDS
1205.15	PAVEMENT MARKINGS - REDUCED CONFLICT INTERSECTIONS
1250.01	RAISED PAVEMENT MARKERS - INSTALLATION SPACING
1251.01	RAISED PAVEMENT MARKERS - PERMANENT AND TEMPORARY

**GENERAL NOTES**

THE FOLLOWING GENERAL NOTES APPLY AT ALL TIMES FOR THE DURATION OF THE CONSTRUCTION PROJECT, EXCEPT WHEN OTHERWISE NOTED IN THE PLAN, OR DIRECTED BY THE ENGINEER.

PAVEMENT MARKING NOTES:

- A) INSTALL PAVEMENT MARKINGS AND PAVEMENT MARKERS ON THE FINAL SURFACE AS FOLLOWS:

ROAD NAME	MARKING	MARKER
-L-	THERMOPLASTIC	PERMANENT RAISED
-Y11-	THERMOPLASTIC	PERMANENT RAISED
- B) TIE PROPOSED PAVEMENT MARKING LINES TO EXISTING PAVEMENT MARKING LINES.
- C) REMOVE/REPLACE ANY CONFLICTING/DAMAGED PAVEMENT MARKINGS AND MARKERS.
- D) STOP BAR LOCATION AT NON-SIGNALIZED INTERSECTIONS MAY BE ADJUSTED AS DIRECTED BY THE ENGINEER.
- E) UNLESS OTHERWISE SPECIFIED, HEATED-IN-PLACE THERMOPLASTIC MAY BE USED IN LIEU OF EXTRUDED THERMOPLASTIC FOR STOP BARS, SYMBOLS, CHARACTERS AND DIAGONALS. IF HEATED-IN-PLACE IS USED, IT SHALL BE PAID FOR USING THE EXTRUDED THERMOPLASTIC PAY ITEM. ALTHOUGH IT IS REQUIRED THAT T90 AND T91 SHALL BE PLACED USING HEATED-IN-PLACE METHOD ONLY.
- F) SEE ROADWAY PLANS FOR ALTERNATE CURB RAMP DESIGNS WHEN INDICATED ON PAVEMENT MARKING DETAIL SHEETS

**PAVEMENT MARKING SCHEDULE**

SYMBOL	DESCRIPTION	SYMBOL	DESCRIPTION
THERMOPLASTIC PAVEMENT MARKINGS (4", 90 MILS)		THERMOPLASTIC PAVEMENT MARKINGS (24", 90 MILS)	
T1	WHITE EDGELINE	T61	WHITE STOPBAR
T2	WHITE SOLID LANE LINE		
T3	10 FT. WHITE SKIP		
T4	3 FT. - 9 FT. WHITE MINISKIP		THERMOPLASTIC PAVEMENT MARKING SYMBOLS (90 MILS)
T5	2 FT. - 6 FT. WHITE MINISKIP		
T10	YELLOW EDGELINE	T70	LEFT TURN ARROW
T13	YELLOW DOUBLE CENTER	T71	RIGHT TURN ARROW
T14	2 FT. - 6 FT./SP YELLOW MINISKIP	T72	STRAIGHT ARROW
		T74	COMBO RIGHT/STRAIGHT ARROW
		T77	U-TURN ARROW
THERMOPLASTIC PAVEMENT MARKINGS (8", 90 MILS)			
T40	WHITE GORELINE		
T46	WHITE CROSSWALK LINE		PERMANENT RAISED PAVEMENT MARKERS
		MA	YELLOW & YELLOW
		MB	CRYSTAL & RED
THERMOPLASTIC PAVEMENT MARKINGS (12", 90 MILS)			
T51	WHITE DIAGONAL		
T52	YELLOW DIAGONAL		

**INDEX**

SHEET NO.	DESCRIPTION
PMP-1	INDEX OF SHEETS, APPLICABLE ROADWAY STANDARDS, PAVEMENT MARKING SCHEDULE AND GENERAL NOTES
PMP-1A	REVISED PAVEMENT MARKING ROADWAY STANDARD DRAWING 1205D04
PMP-2 THRU PMP-10	PAVEMENT MARKING PLANS

**PLAN REVIEWED BY: N.C.D.O.T. SIGNING AND DELINEATION UNIT**

MITCH EATON, P.E.	SIGNING & DELINEATION REGIONAL ENGINEER
STACEY JOHNS	SIGNING & DELINEATION PROJECT DESIGN ENGINEER

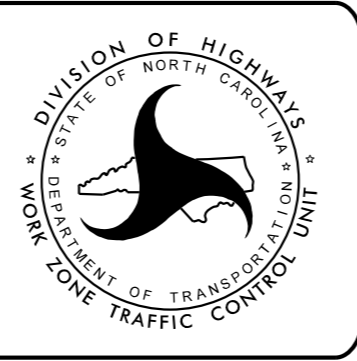

**PLAN PREPARED BY: Kimley-Horn and Associates**

VANCE BLANTON, P.E.	PROJECT DESIGN ENGINEER
TYLER SPRING, P.E.	DESIGNER



TIP NO.	SHEET NO.
R-5930B	DocuSigned by: Matthew V. Springer
APPROVED:	8/13/2019
DATE:	8/13/2019
SEAL	

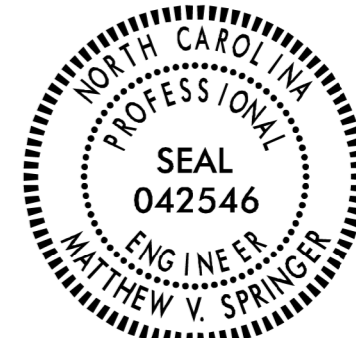

STATE OF NORTH CAROLINA  
 DEPT. OF TRANSPORTATION  
 DIVISION OF HIGHWAYS  
 RALEIGH, N.C.

ENGLISH DETAIL DRAWING FOR  
**PAVEMENT MARKINGS**  
 INTERSECTIONS

SHEET 2 OF 2  
**1205D04**

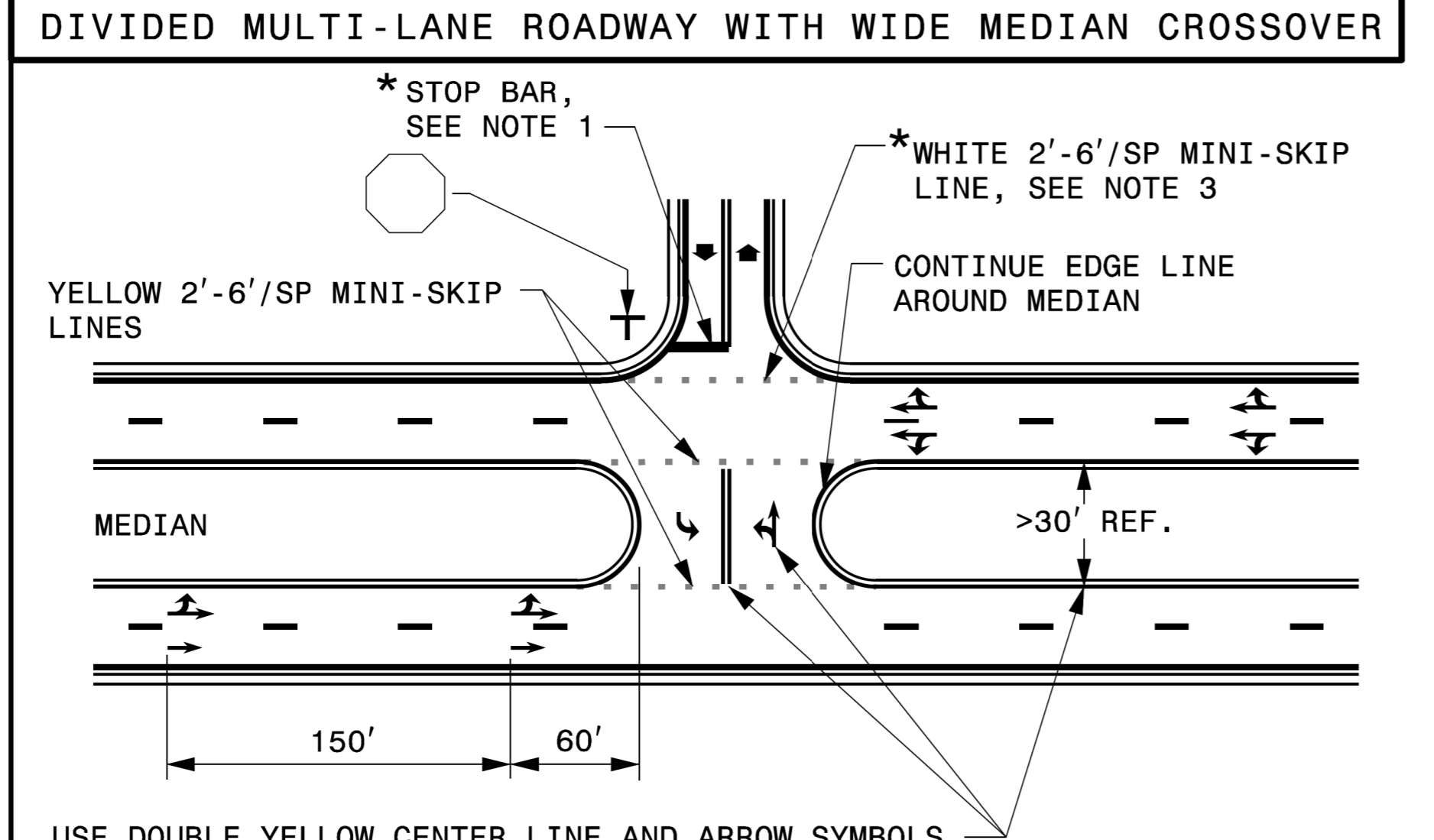
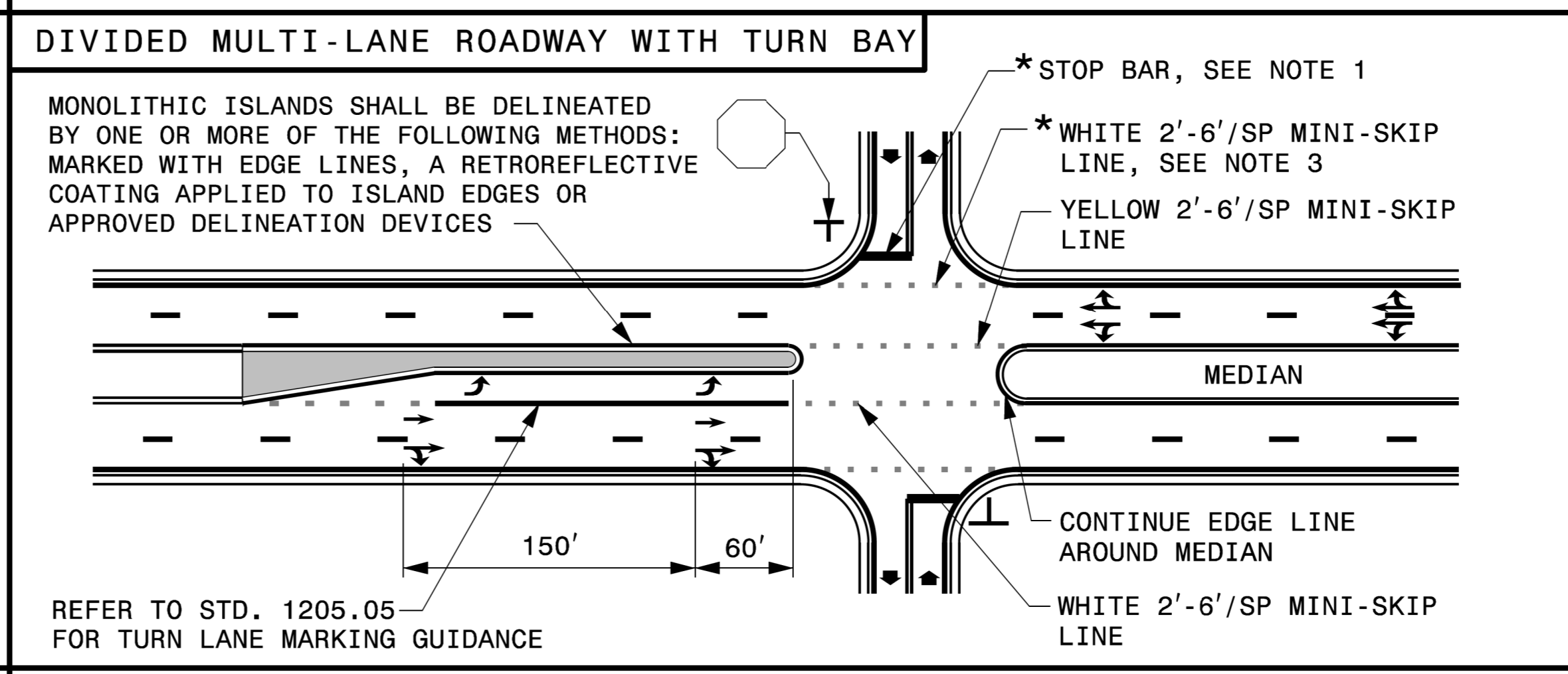
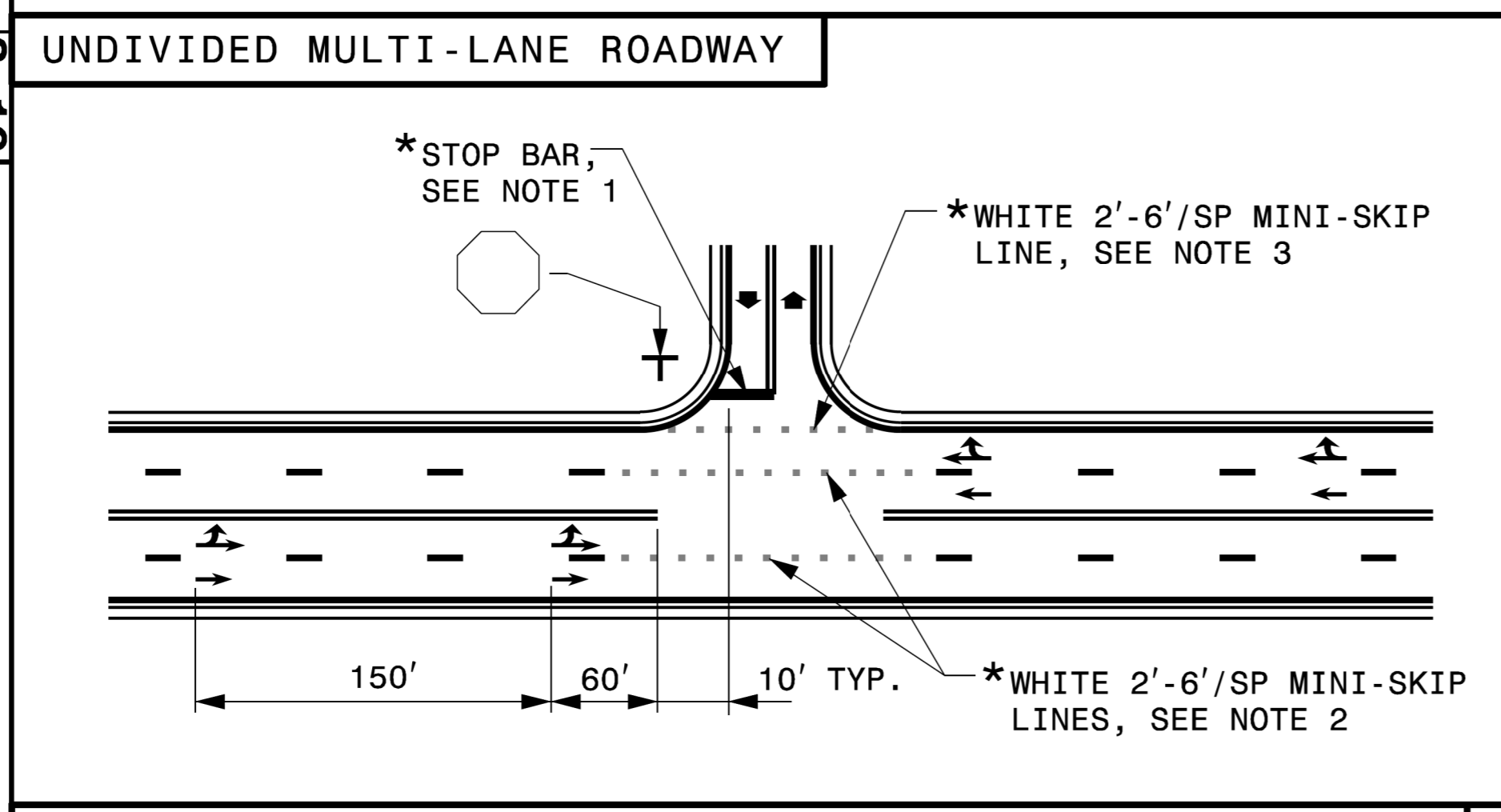
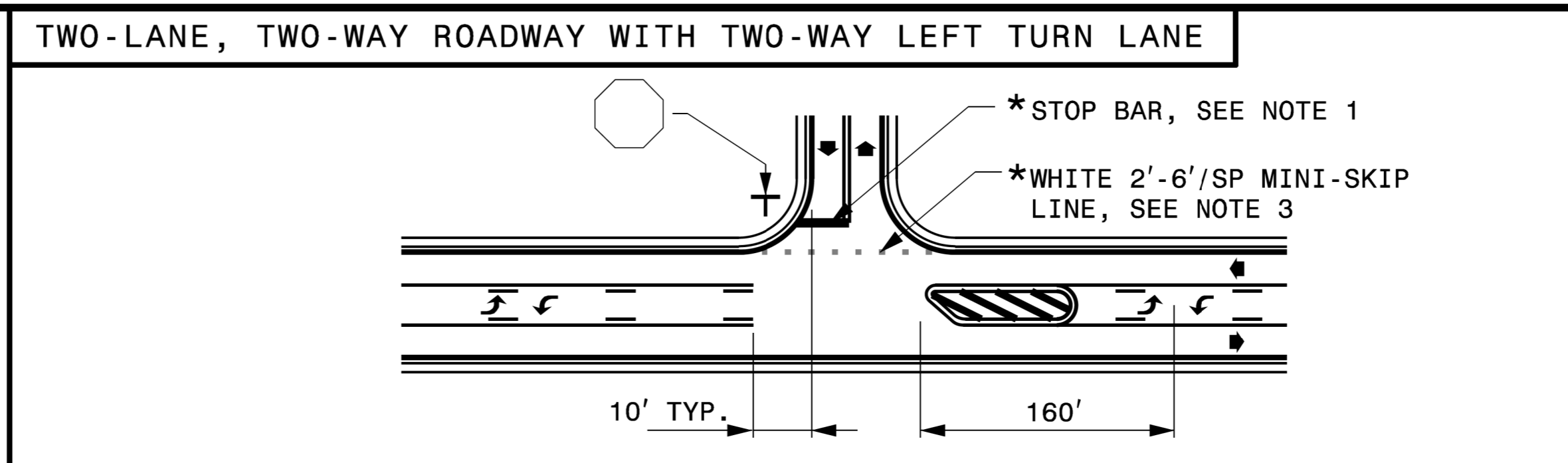
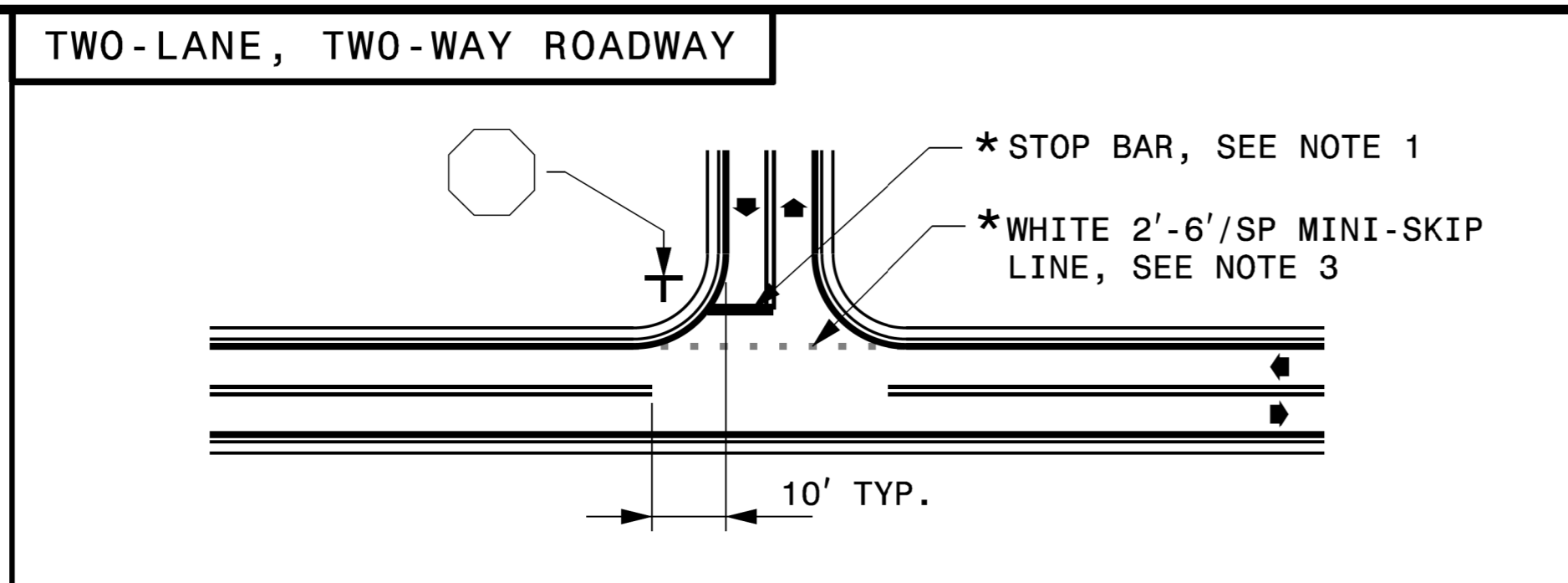

**GENERAL NOTES:**

- 1- PLACEMENT OF STOP BARS AT NON-SIGNALIZED INTERSECTIONS IS OPTIONAL AND USED WHERE IT IS IMPORTANT TO INDICATE THE POINT WHICH VEHICLES ARE REQUIRED TO STOP. PLACE STOP BARS NO LESS THAN 4 FEET AND NO MORE THAN 30 FEET FROM THE NEAREST EDGE OF THE INTERSECTING ROADWAY. USE 10 FEET AS THE TYPICAL SETBACK DISTANCE OR AS DIRECTED BY THE ENGINEER.
- 2- MINI-SKIP LANE LINE EXTENSIONS SHOULD BE USED AT INTERSECTIONS THAT HAVE REDUCED VISIBILITY CONDITIONS SUCH AS OFFSET, SKEWED, OR CURVED ROADWAYS.
- 3- MINI-SKIP EDGE LINE EXTENSIONS MAY BE PLACED THROUGH INTERSECTIONS AND MAJOR DRIVEWAYS.
- 4- REFER TO ROADWAY STANDARD DRAWINGS 1205.01, 1205.02, 1205.05, 1205.08 AND 1205.09 FOR ADDITIONAL PAVEMENT MARKING GUIDANCE.

LEGEND	
STOP SIGN	STATIONARY SIGN
DIRECTION OF TRAFFIC FLOW	PAVEMENT MARKING SYMBOLS
* OPTIONAL	

USE DOUBLE YELLOW CENTER LINE AND ARROW SYMBOLS IN MEDIAN CROSSOVER WHEN WIDTH OF MEDIAN EXCEEDS 30 FT, OTHERWISE THEY ARE NOT REQUIRED.

STATE OF NORTH CAROLINA  
 DEPT. OF TRANSPORTATION  
 DIVISION OF HIGHWAYS  
 RALEIGH, N.C.

ENGLISH DETAIL DRAWING FOR  
**PAVEMENT MARKINGS**  
 INTERSECTIONS

SHEET 2 OF 2  
**1205D04**

**REVISED PAVEMENT MARKING ROADWAY STANDARD DRAWING**

TIP NO. R-5930B	SHEET NO. PMP-2
APPROVED: _____	
DATE: _____	
SEAL	
	
12/9/2024	
<b>DOCUMENT NOT CONSIDERED FINAL UNLESS ALL SIGNATURES COMPLETED</b>	

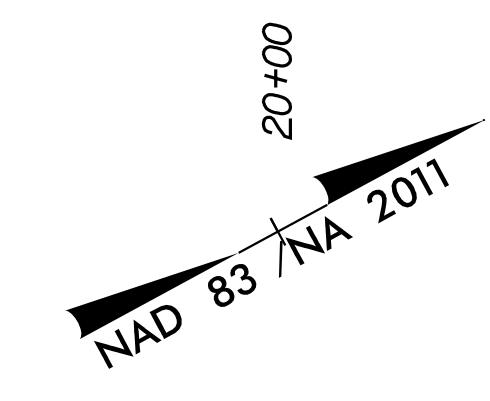

K:\PAL\_Roadway\01036532 - R-5930 North CPW Roadway\Proj\5930B\_rdy\_pmp\_02.dgn  
12/6/2024

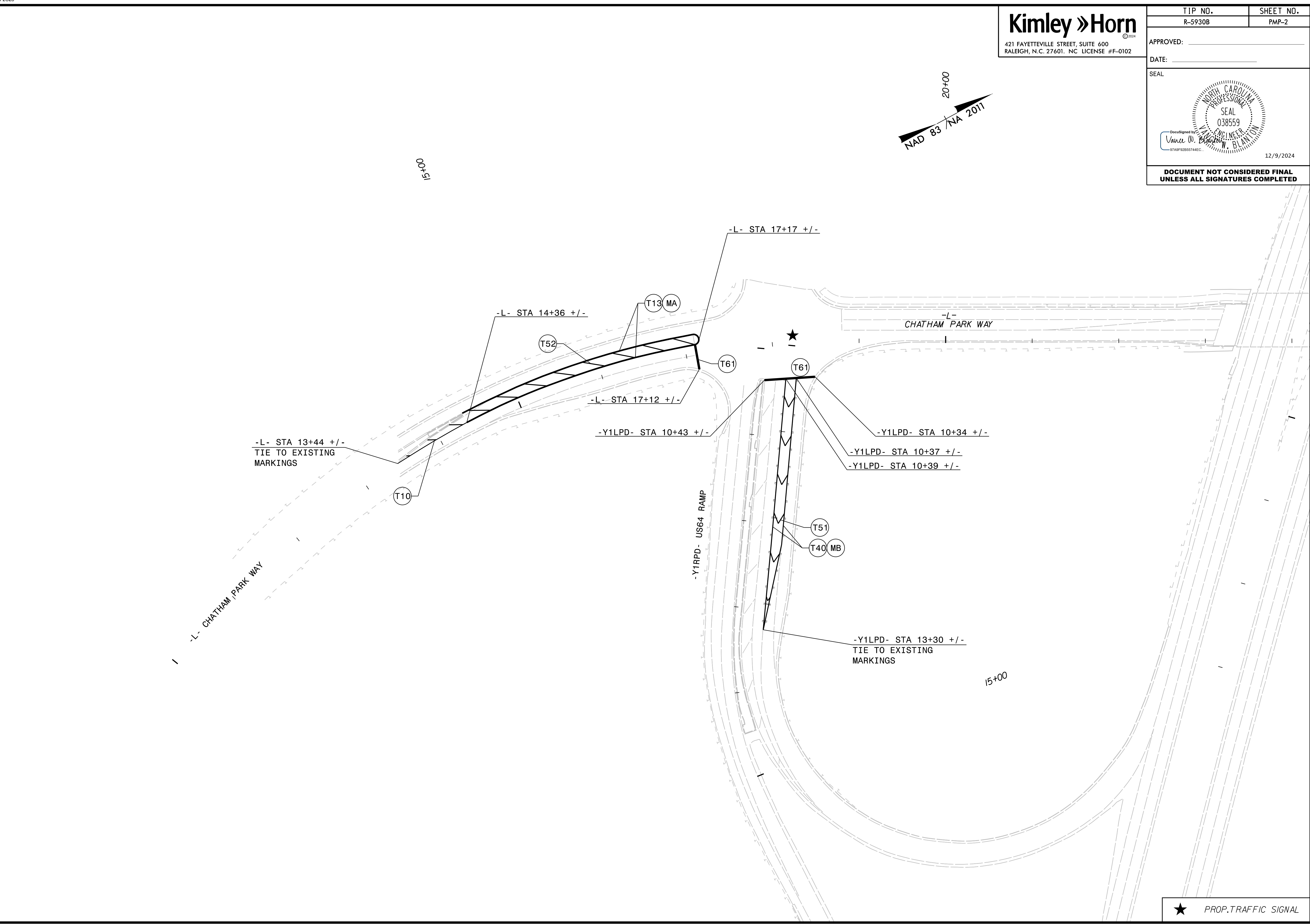

★ PROP. TRAFFIC SIGNAL

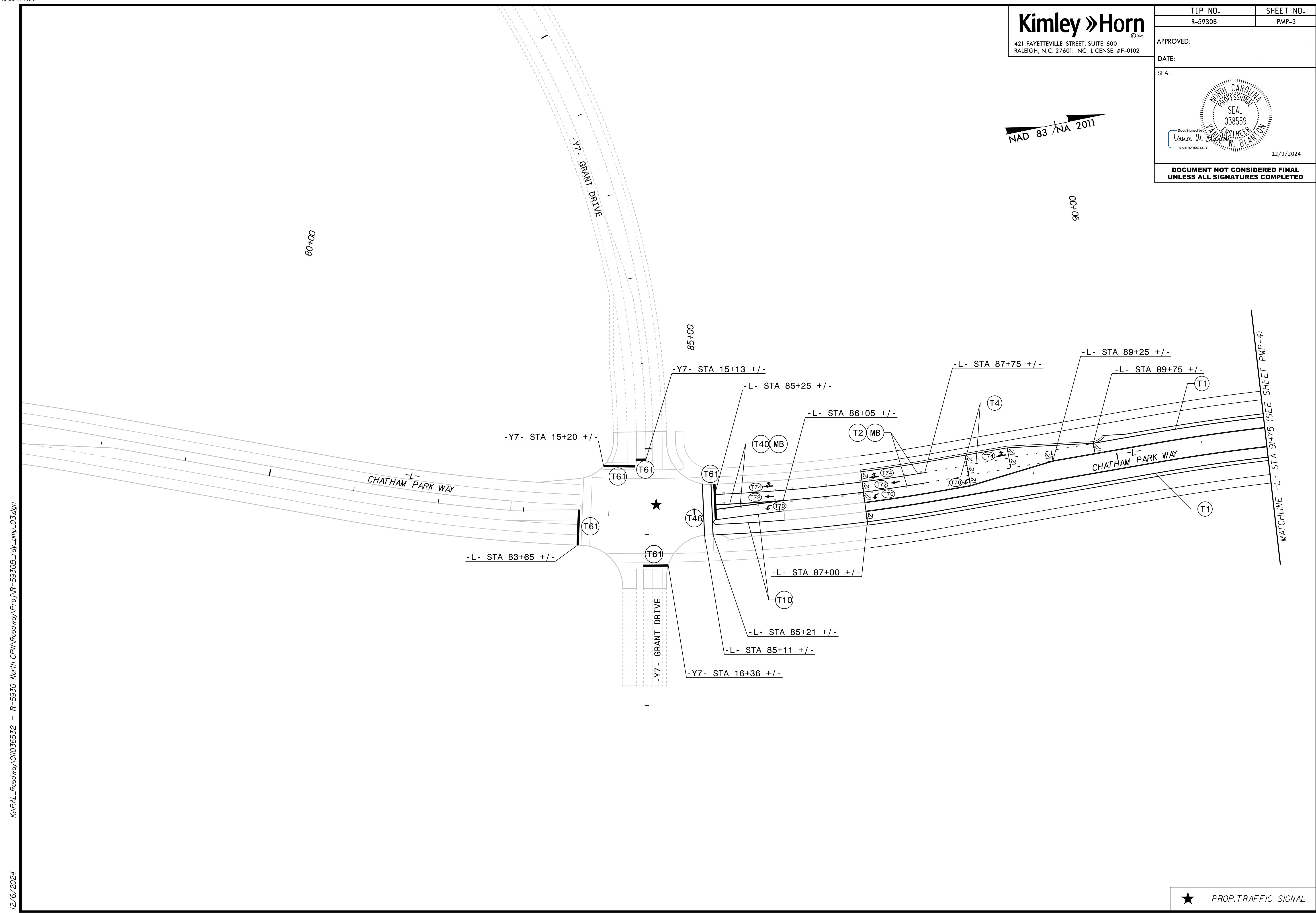
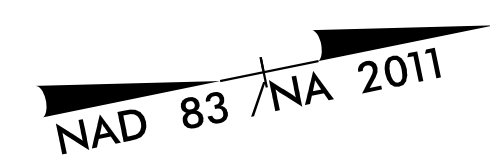
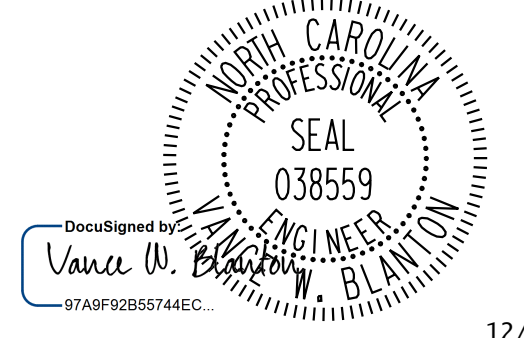

K:\PAL\_Roadway\01036532 - R-5930 North CPW Roadway\Proj\R-5930B\_rdy\_pmp\_03.dgn 12/6/2024

## Kimley » Horn

421 FAYETTEVILLE STREET, SUITE 600  
RALEIGH, N.C. 27601. NC LICENSE #F-0102

TIP NO. R-5930B	SHEET NO. PMP-4
--------------------	--------------------

APPROVED: \_\_\_\_\_

DATE: \_\_\_\_\_

SEAL

DocuSigned by:  
Vance W. Blanton  
97A8F92B55744EC

1/7/2025

DOCUMENT NOT CONSIDERED FINAL  
UNLESS ALL SIGNATURES COMPLETED

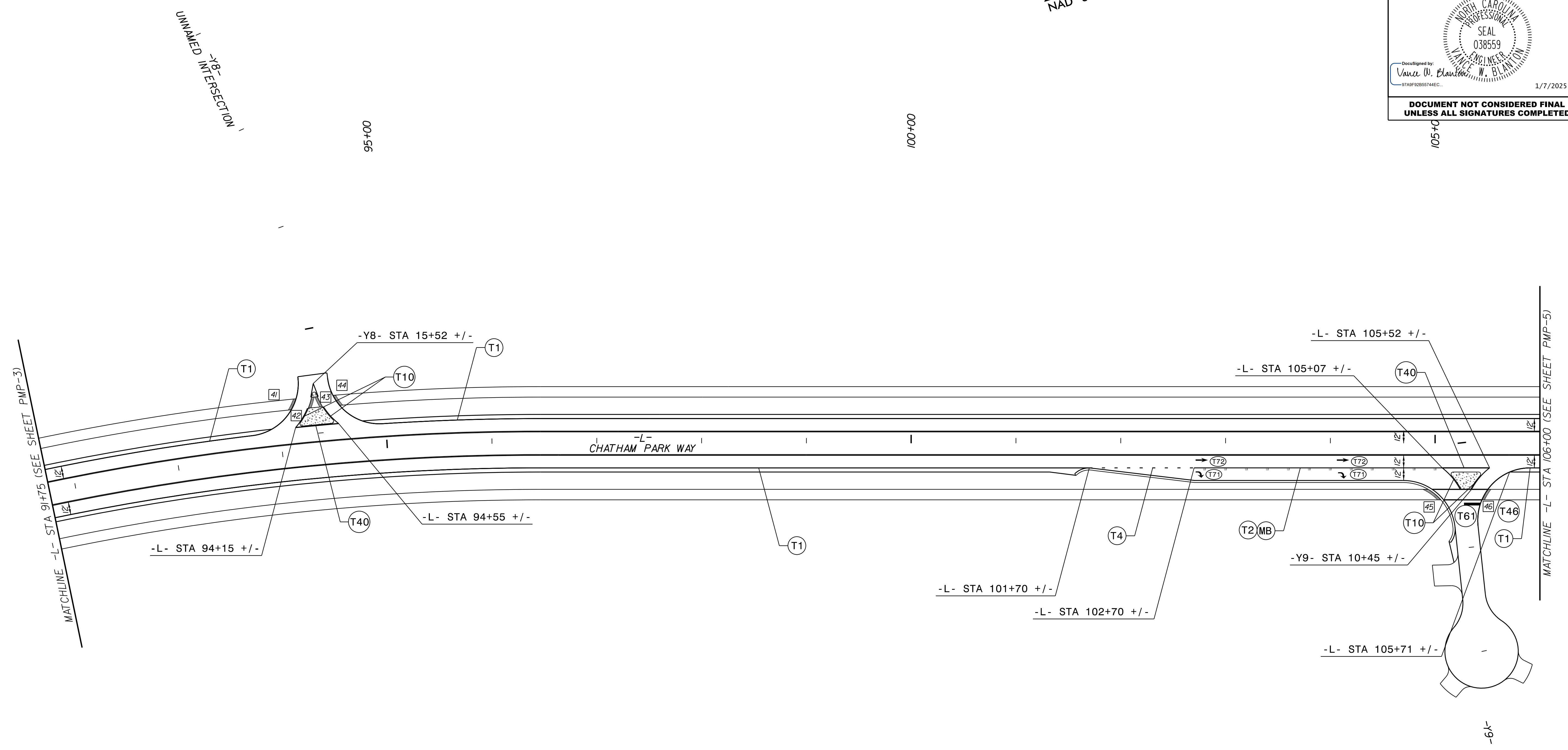
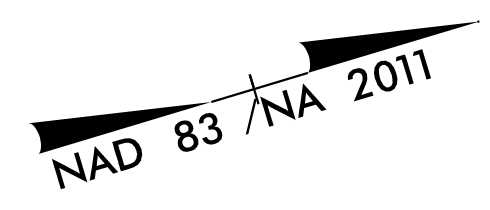

K:\PAL\_Roadway\01036532 - R-5930 North CPW Roadway\Proj\R-5930B\_rdy\_pmp\_04.dgn 1/3/2025

CURB RAMP (CR) SUMMARY				
CR ID	CR TYPE	ALIGNMENT	STATION	OFFSET
41	1 MODIFIED	-L-	94+14	50' LT
42	7	-L-	94+30	50' LT
43	7	-L-	94+40	50' LT
44	1 MODIFIED	-L-	94+56	50' LT
45	1 MODIFIED	-L-	104+98	50' RT
46	1 MODIFIED	-L-	105+49	50' RT

NOTE: ENGINEER TO APPROVE LOCATION OF ALL UNSIGNALIZED STOP BARS

NAD 83 / NA 2011

**Kimley » Horn**  
 421 FAYETTEVILLE STREET, SUITE 600  
 RALEIGH, N.C. 27601. NC LICENSE #F-0102

TIP NO. R-5930B	SHEET NO. PMP-5
--------------------	--------------------

APPROVED: \_\_\_\_\_  
 DATE: \_\_\_\_\_

SEAL

DocuSigned by:  
 Vance W. Blanton  
 97AF9255T44EC.

12/9/2024

**DOCUMENT NOT CONSIDERED FINAL  
 UNLESS ALL SIGNATURES COMPLETED**

REVISIONS

K:\PAL\_Roadway\01036532 - R-5930 North CPW Roadway\Pro\N\R-5930B\_rdy\_pmp\_05.dgn  
12/6/2024

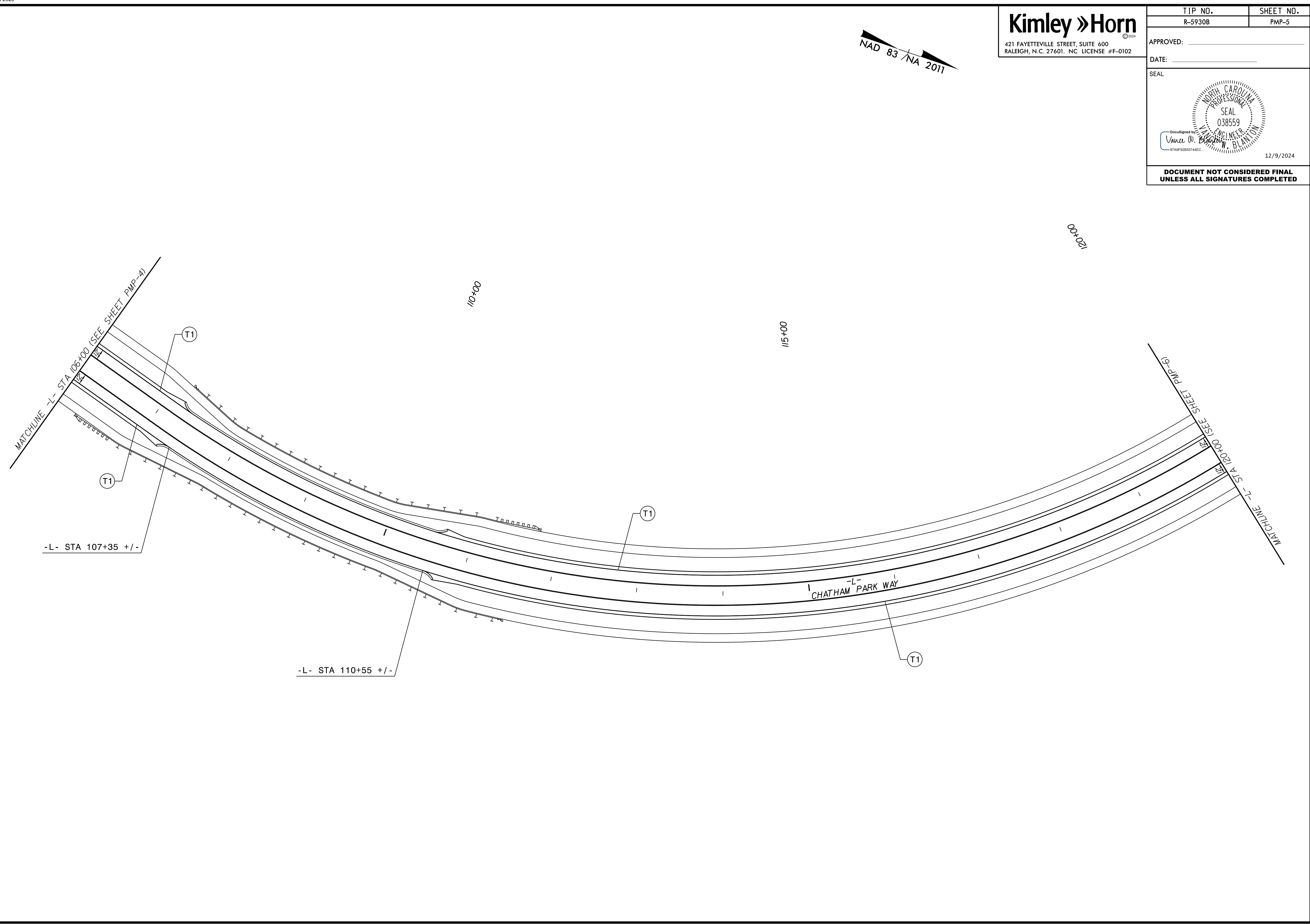

TIP NO. R-5930B	SHEET NO. PMP-6
APPROVED: _____	
DATE: _____	
SEAL	
DocuSigned by: Vance W. Blanton 97A8F92B55744EC... 1/7/2025	
<b>DOCUMENT NOT CONSIDERED FINAL UNLESS ALL SIGNATURES COMPLETED</b>	

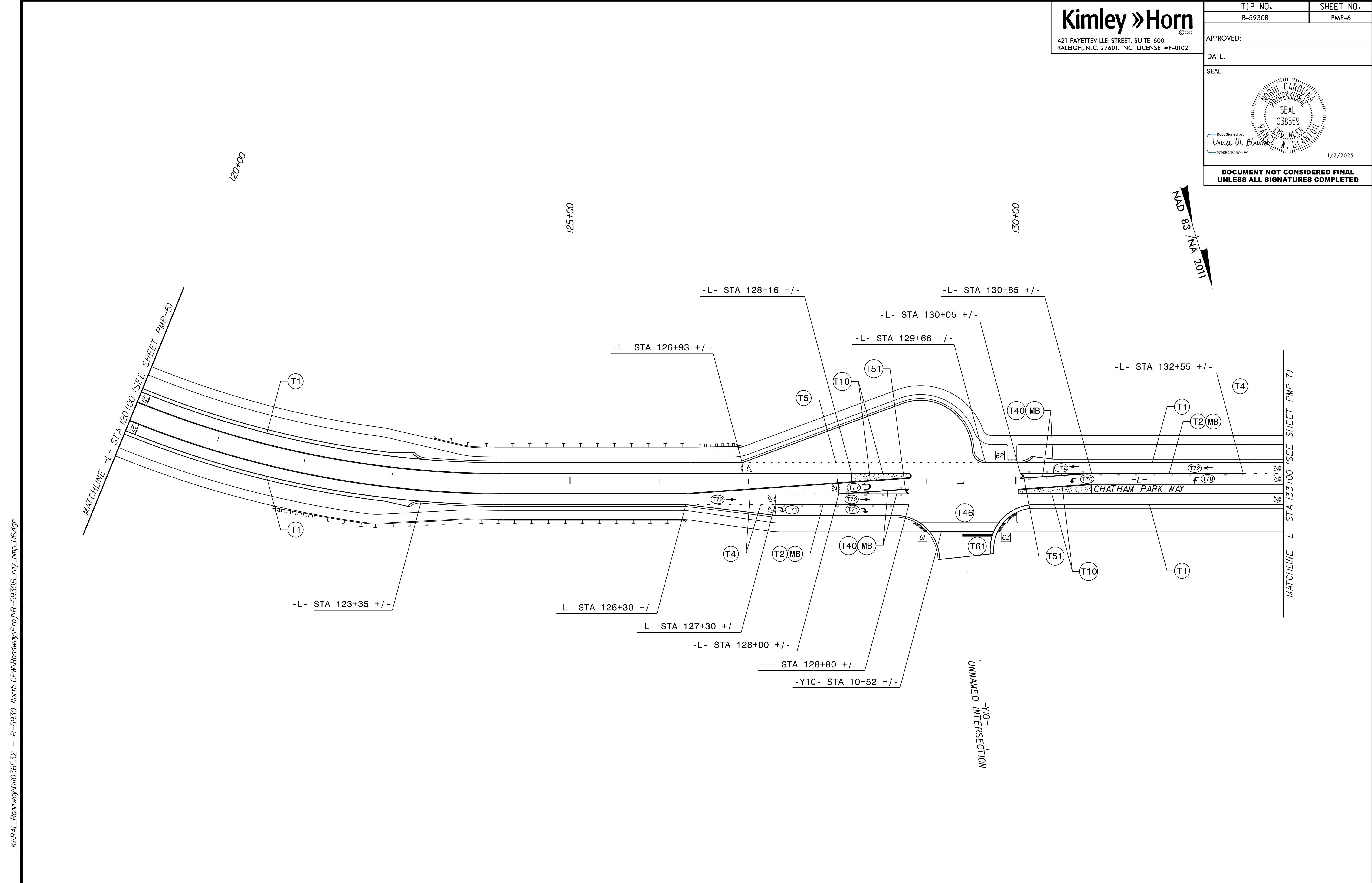

K:\PAL\_Roadway\01036532 - R-5930 North CPW Roadway\Proj\R-5930B\_rdy\_pmp\_06.dgn

1/3/2025

CURB RAMP (CR) SUMMARY				
CR ID	CR TYPE	ALIGNMENT	STATION	OFFSET
61	1 MODIFIED	-L-	128+94	50' RT
62	1 MODIFIED	-L-	129+96	25' LT
63	5	-L-	129+90	45' RT

NOTE: ENGINEER TO APPROVE LOCATION OF ALL UNSIGNALIZED STOP BARS

TIP NO. R-5930B	SHEET NO. PMP-7
APPROVED: _____	
DATE: _____	
SEAL	
	
12/9/2024	
<b>DOCUMENT NOT CONSIDERED FINAL UNLESS ALL SIGNATURES COMPLETED</b>	

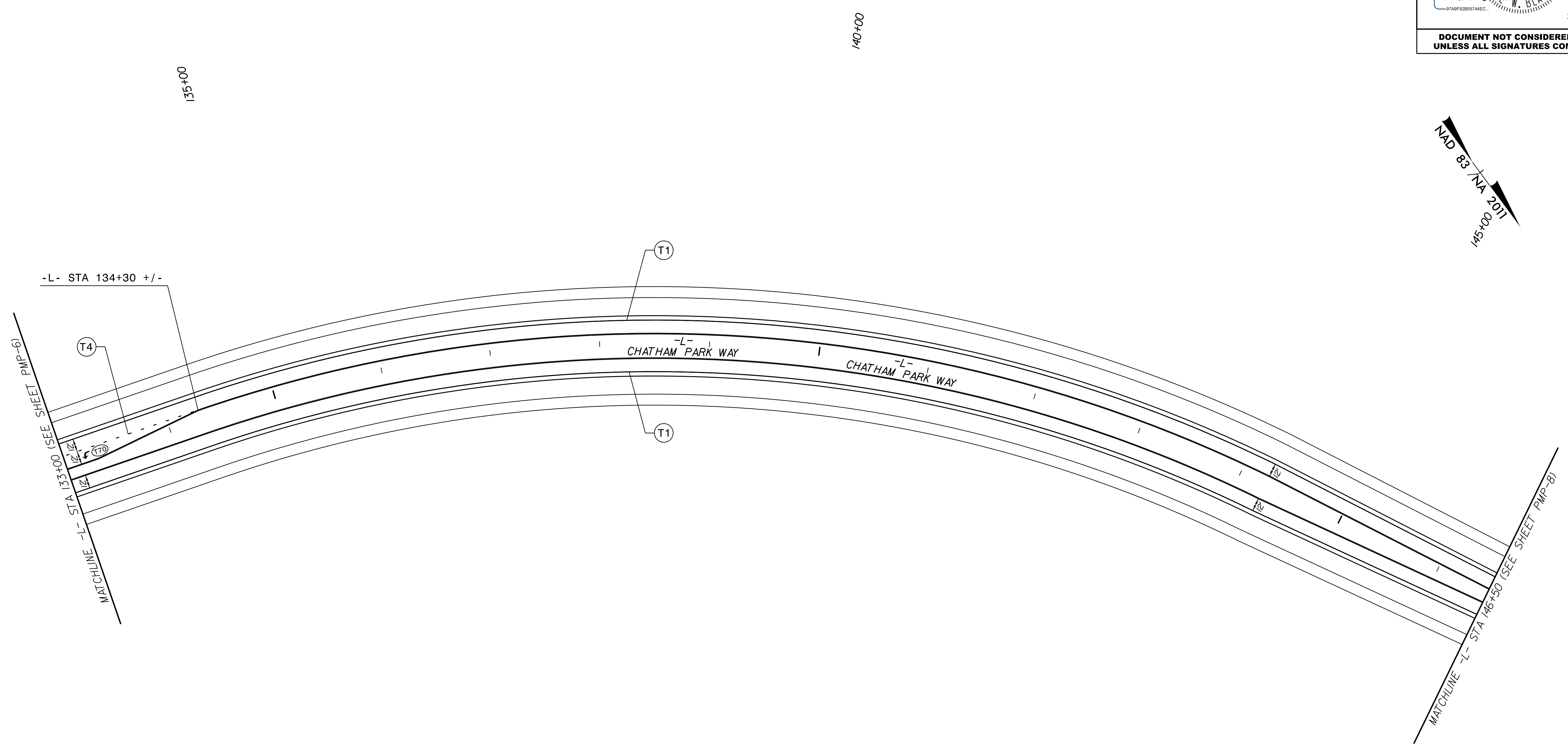
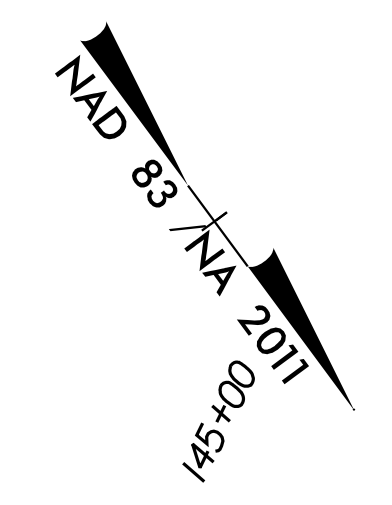

12/6/2024 K:\PAL\_Roadway\01036532 - R-5930 North CPW Roadway\Pro\AR-5930B\_rdy\_pmp\_07.dgn



TIP NO. R-5930B	SHEET NO. PMP-8
APPROVED: _____	
DATE: _____	
SEAL	
12/9/2024	
<b>DOCUMENT NOT CONSIDERED FINAL UNLESS ALL SIGNATURES COMPLETED</b>	

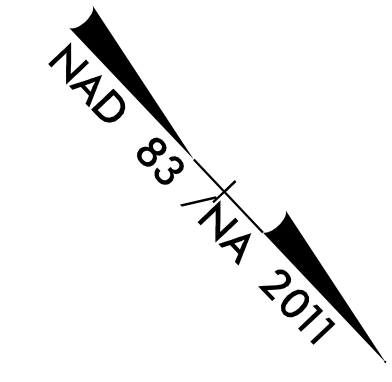

160+00

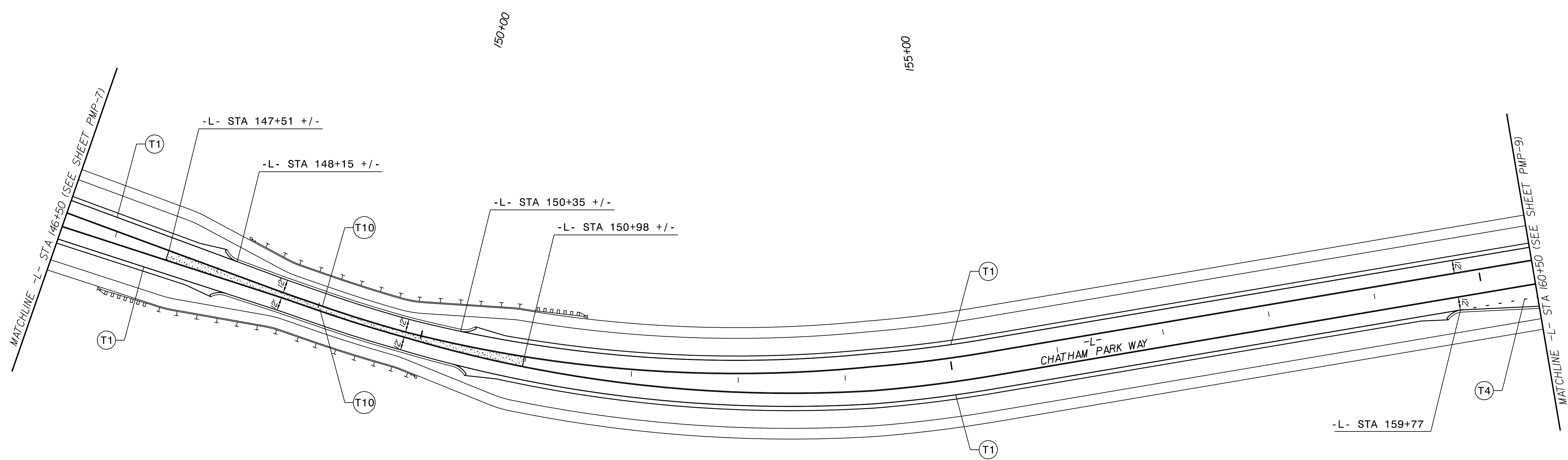

12/6/2024 K:\PAL\_Roadway\01036532 - R-5930 North CPW Roadway\Proj\R-5930B\_rdy\_pmp\_08.dgn

## Kimley » Horn

421 FAYETTEVILLE STREET, SUITE 600  
RALEIGH, N.C. 27601. NC LICENSE #F-0102

TIP NO. R-5930B	SHEET NO. PMP-9
--------------------	--------------------

APPROVED: \_\_\_\_\_

DATE: \_\_\_\_\_

SEAL

DocuSigned by:  
*Vance W. Blanton*  
97A9F92B55744EC... 1/7/2025

**DOCUMENT NOT CONSIDERED FINAL  
UNLESS ALL SIGNATURES COMPLETED**

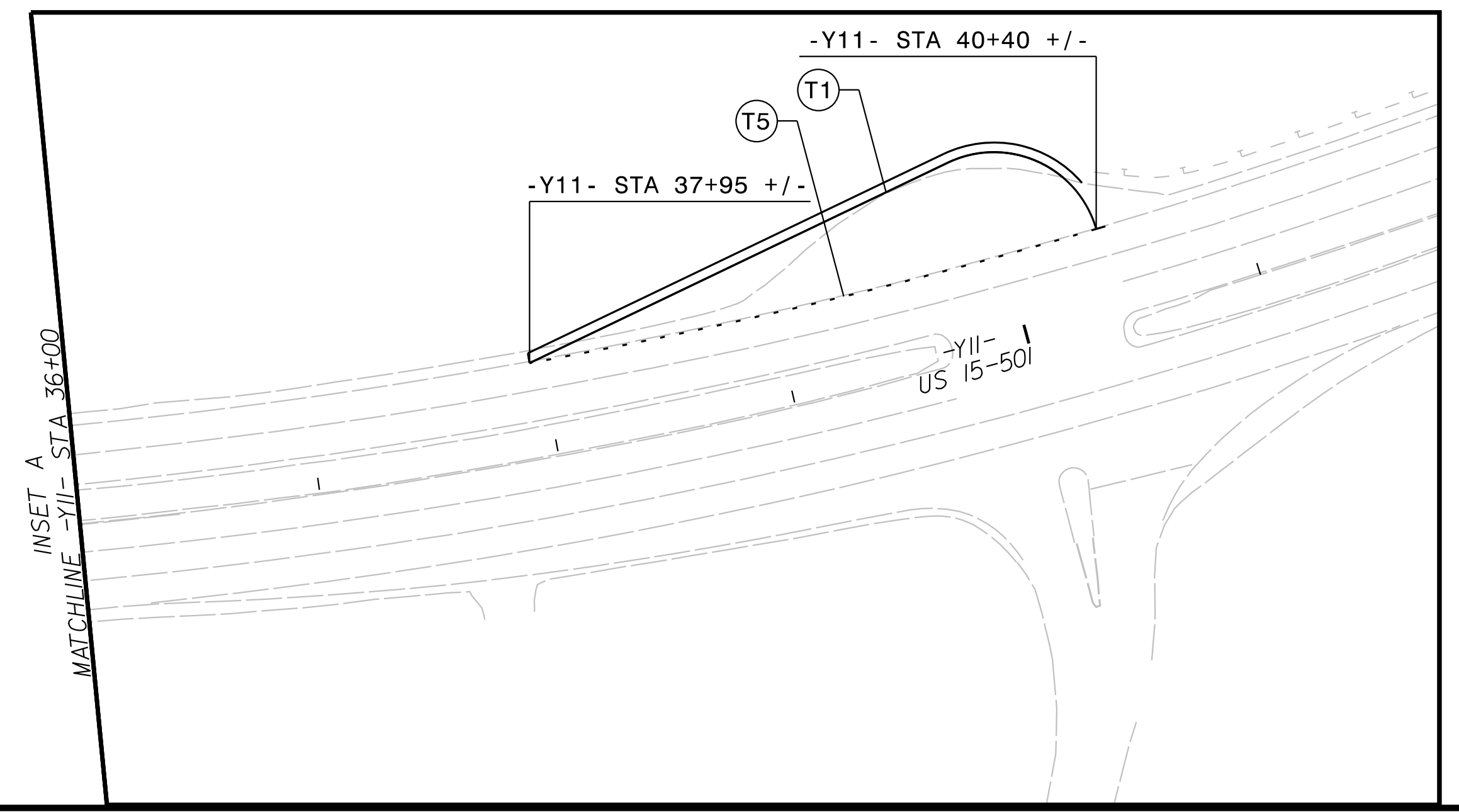
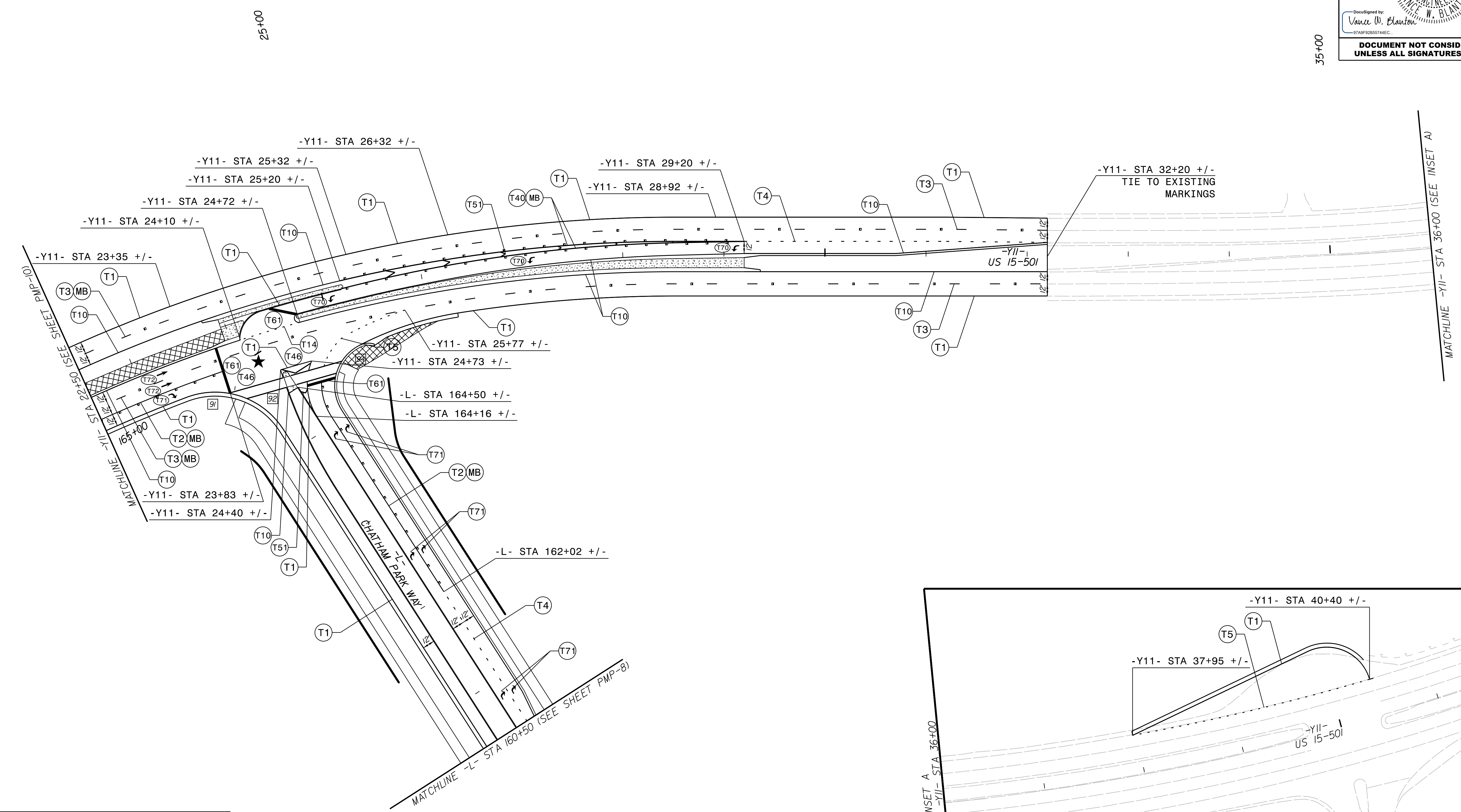
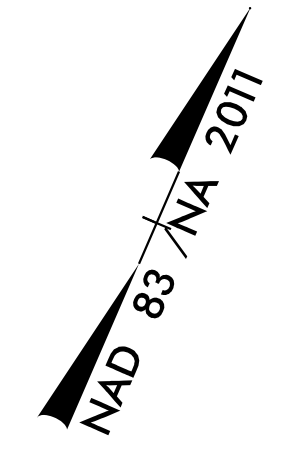

★ INDICATES SIGNALIZED INTERSECTION

CURB RAMP (CR) SUMMARY				
CR ID	CR TYPE	ALIGNMENT	STATION	OFFSET
91	3 MODIFIED	-Y11-	23+80	65' RT
92	7	-Y11-	24+40	65' RT
93	7	-Y11-	24+50	65' RT
94	3 MODIFIED	-Y11-	25+00	70' RT

K:\RAL\_Roadway\01036532 - R-5930 North CPW Roadway\Proj\R-5930B\_rdy\_pmp\_09.dgn 1/3/2025

**Kimley » Horn**  
 421 FAYETTEVILLE STREET, SUITE 600  
 RALEIGH, N.C. 27601. NC LICENSE #F-0102

TIP NO. R-5930B	SHEET NO. PMP-10
--------------------	---------------------

APPROVED: \_\_\_\_\_  
 DATE: \_\_\_\_\_

SEAL

DocuSigned by:  
 Vance W. Blanton  
 97AF9255144EC

12/9/2024

**DOCUMENT NOT CONSIDERED FINAL  
 UNLESS ALL SIGNATURES COMPLETED**

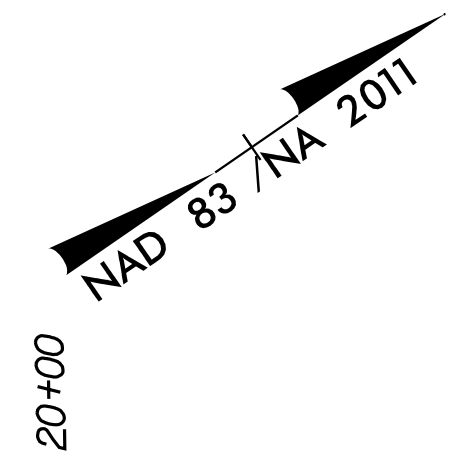

10+00

15+00

20+00

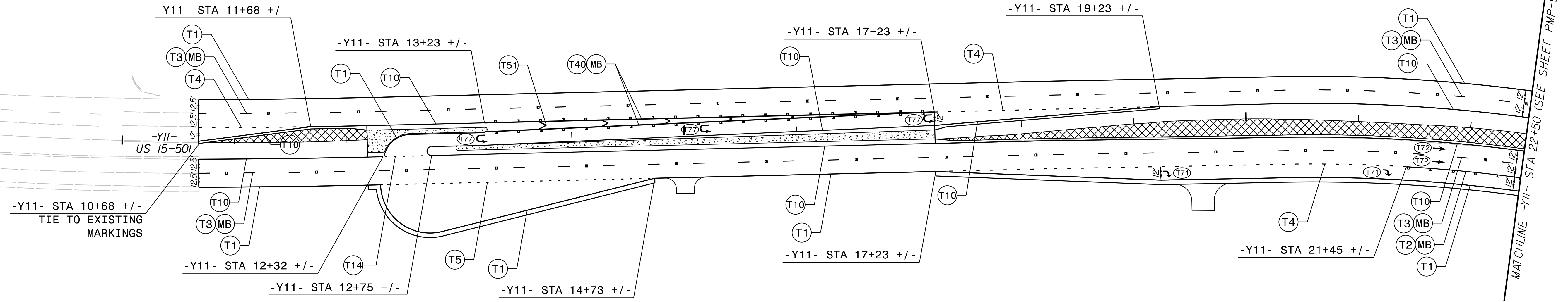

12/6/2024 K:\PAL\_Roadway\01036532 - R-5930 North CPW Roadway\Proj\R-5930B\_rdy\_pmp\_10.dgn

MATCHLINE -Y11- STA 22+50 (SEE SHEET PMP-9)