

### 18 CHANNEL CONFLICT MONITOR PROGRAMMING DETAIL

(remove jumpers and set switches as shown)

REMOVE DIODE JUMPERS 1-6, 1-9, 1-10, 2-6, 2-9, 2-11, 5-8, 5-10, 6-9, 6-10, 6-11, 8-10, 8-11, 9-10, 9-11 and 10-11

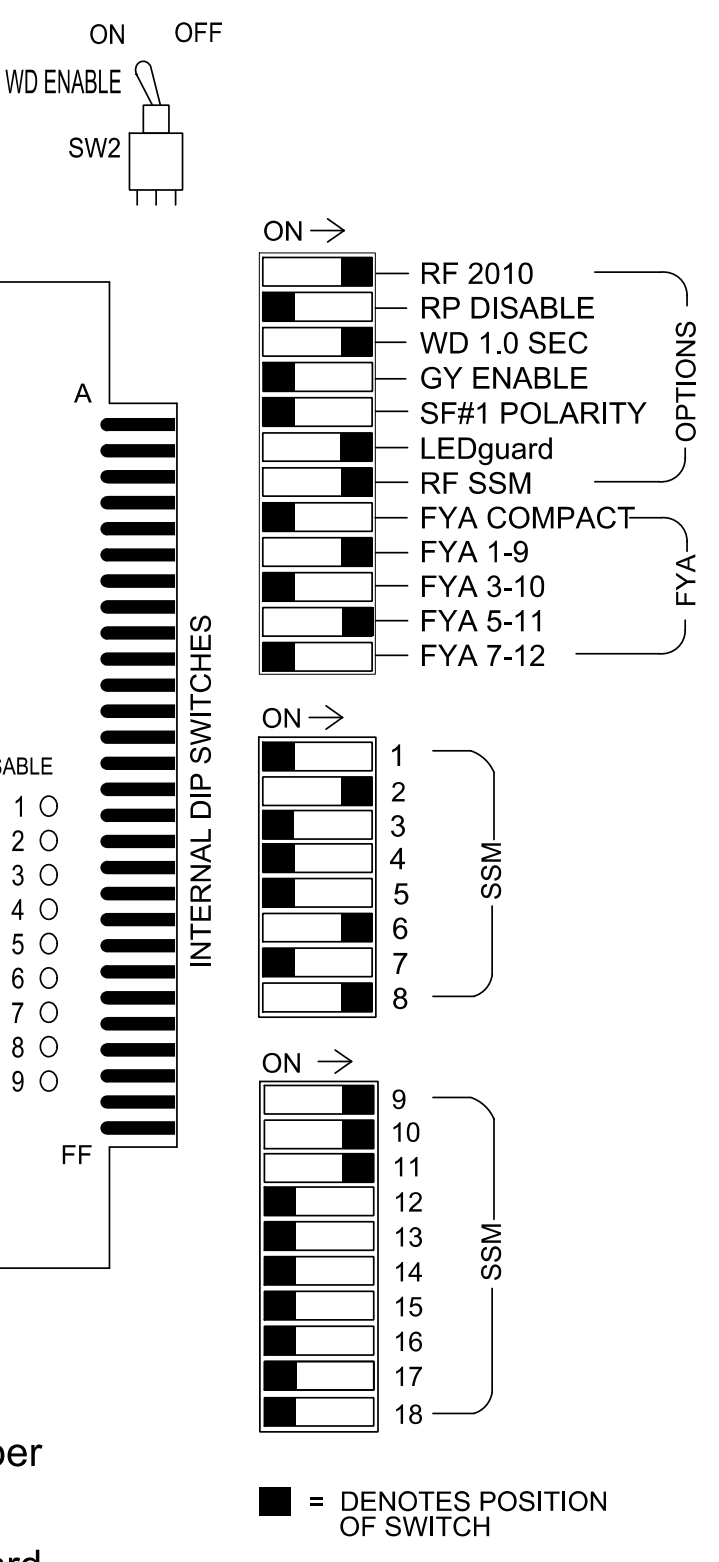
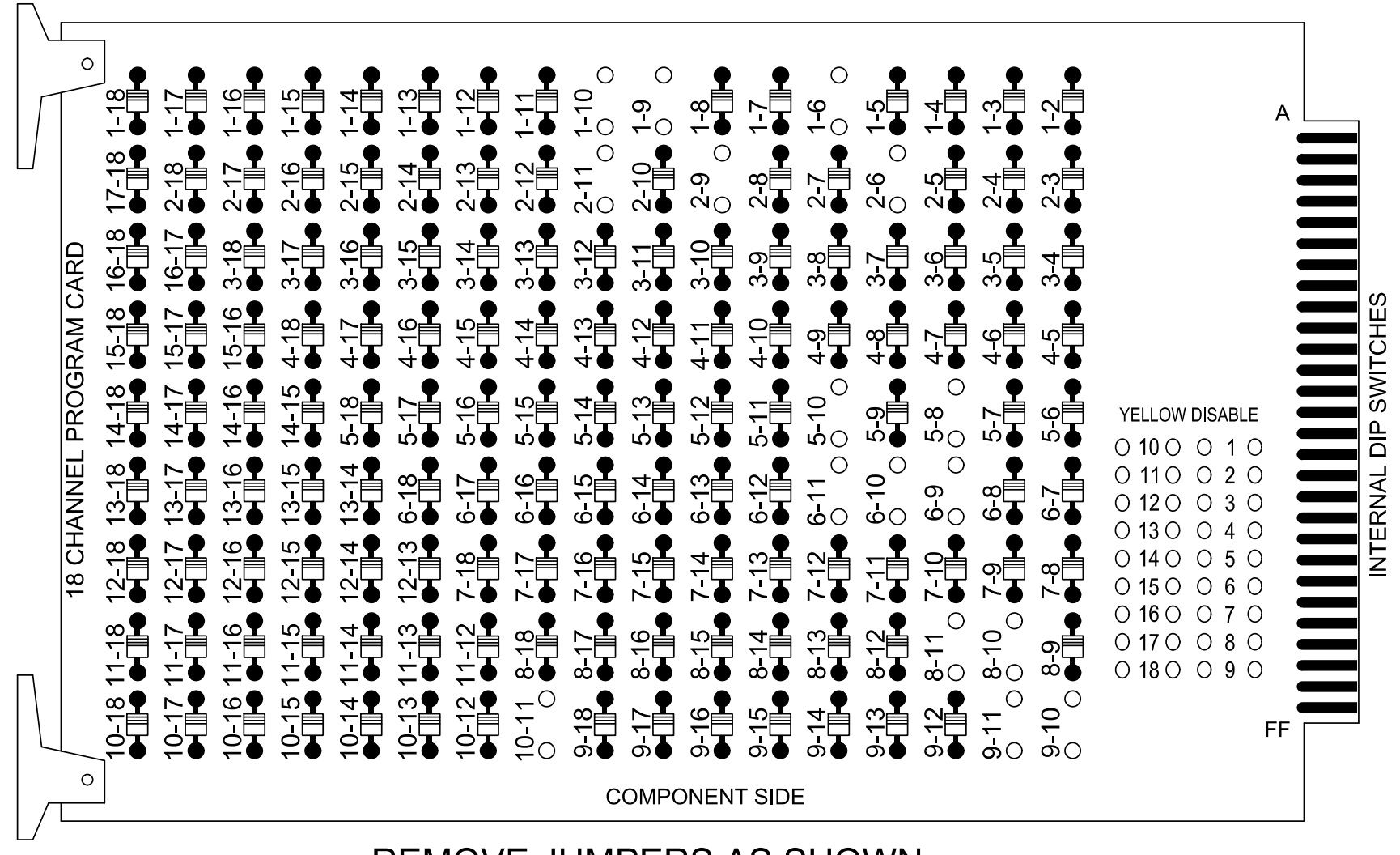

REMOVE JUMPERS AS SHOWN

NOTES:

- Card is provided with all diode jumpers in place. Removal of any jumper allows its channels to run concurrently.
- Ensure jumpers SEL2-SEL5 and SEL9 are present on the monitor board.
- Ensure that the Red Enable is active at all times during normal operation.
- Connect serial cable from conflict monitor to comm. port 1 of 2070 controller. Ensure conflict monitor communicates with 2070.

### NOTES

- To prevent "flash-conflict" problems, insert red flash program blocks for all vehicle load switches in the output file. The installer shall verify that signal heads flash in accordance with the signal plan.
- Program controller to start up in phase 2 Green No Walk and 6 Green No Walk.
- If this signal will be managed by an ATMS software, enable controller and detector logging for all detectors used at this location.
- The cabinet and controller are part of the (SR 2700 (Chatham Park Way) Closed Loop System) Signal System #: D08-35\_Pittsboro.

### EQUIPMENT INFORMATION

Controller.....2070LX  
 Cabinet.....332 w/ Aux  
 Software.....Q-Free MAXTIME  
 Cabinet Mount.....Base  
 Output File Positions.....18 With Aux. Output File  
 Load Switches Used.....S1, S2, S7, S8, S11, AUX S1, AUX S2, AUX S4  
 Phases Used.....1,2,6,8  
 Overlap "1".....\*  
 Overlap "2".....\*  
 Overlap "3".....\*  
 Overlap "4".....NOT USED  
 Overlap "5".....NOT USED  
 Overlap "6".....NOT USED  
 Overlap "7".....\*

\*See overlap programming detail on sheet 2

### SIGNAL HEAD HOOK-UP CHART

| LOAD SWITCH NO.       | S1  | S2  | S3    | S4 | S5 | S6    | S7  | S8  | S9    | S10 | S11 | S12   | AUX S1 | AUX S2 | AUX S3 | AUX S4 | AUX S5 | AUX S6 |
|-----------------------|-----|-----|-------|----|----|-------|-----|-----|-------|-----|-----|-------|--------|--------|--------|--------|--------|--------|
| CMU CHANNEL NO.       | 1   | 2   | 13    | 3  | 4  | 14    | 5   | 6   | 15    | 7   | 8   | 16    | 9      | 10     | 17     | 11     | 12     | 18     |
| PHASE                 | 1   | 2   | 2 PED | 3  | 4  | 4 PED | OL7 | 6   | 6 PED | 7   | 8   | 8 PED | OL1    | OL2    | SPARE  | OL3    | OL4    | SPARE  |
| SIGNAL HEAD NO.       | 11  | 21  | 22    | NU | NU | NU    | 23  | 61  | 62    | NU  | NU  | 81    | 11     | 82     | NU     | 23     | NU     | NU     |
| RED                   | 128 | 128 |       |    |    |       |     | 134 | 134   |     |     | 107   |        | A124   |        | A114   |        |        |
| YELLOW                | *   | 129 | 129   |    |    |       |     | *   | 135   | 135 |     |       |        |        |        |        |        |        |
| GREEN                 |     |     | 130   |    |    |       |     |     | 136   |     |     |       |        |        |        |        |        |        |
| RED ARROW             |     |     |       |    |    |       |     |     |       |     |     |       |        | A121   |        |        |        |        |
| YELLOW ARROW          |     |     |       |    |    |       |     |     |       |     |     | 108   |        | A122   | A125   |        | A115   |        |
| FLASHING YELLOW ARROW |     |     |       |    |    |       |     |     |       |     |     |       |        | A123   |        |        | A116   |        |
| GREEN ARROW           | 127 | 130 |       |    |    |       |     | 133 | 136   |     |     | 109   |        | A126   |        |        |        |        |

NU = Not Used  
 \* Denotes install load resistor. See load resistor installation detail this sheet.  
 ★ See pictorial of head wiring in detail this sheet.

### FYA SIGNAL WIRING DETAIL

(wire signal heads as shown)

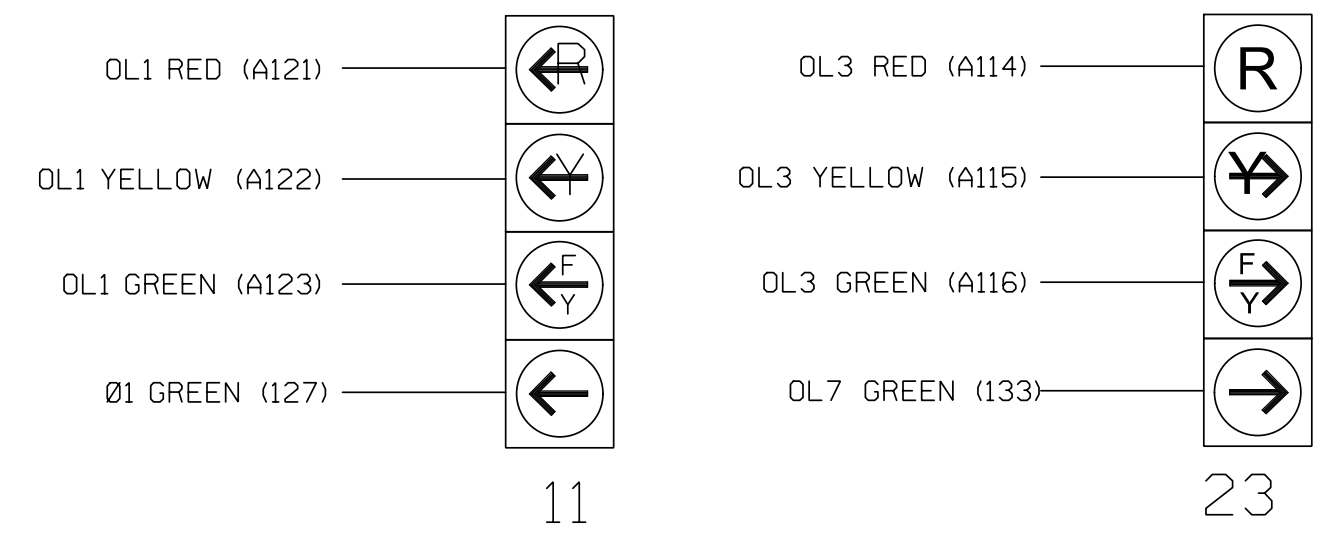

### INPUT FILE POSITION LAYOUT

(front view)

| FILE "I" | 1         | 2         | 3         | 4         | 5         | 6         | 7         | 8         | 9         | 10        | 11        | 12        | 13        | 14        |
|----------|-----------|-----------|-----------|-----------|-----------|-----------|-----------|-----------|-----------|-----------|-----------|-----------|-----------|-----------|
| U        | ∅ 1<br>1A | ∅ 1<br>1B | ∅ 2<br>2A | ∅ 1<br>1A | ∅ 1<br>1B | ∅ 1<br>1A | ∅ 1<br>1B | ∅ 1<br>1A | ∅ 1<br>1B | ∅ 1<br>1A | ∅ 1<br>1B | ∅ 1<br>1A | ∅ 1<br>1B | ∅ 1<br>1A |
| L        | NOT USED  | NOT USED  | NOT USED  | NOT USED  | NOT USED  | NOT USED  | NOT USED  | NOT USED  | NOT USED  | NOT USED  | NOT USED  | NOT USED  | NOT USED  | NOT USED  |
| U        | ∅ 6<br>6A | ∅ 6<br>6A | ∅ 6<br>6A | ∅ 6<br>6A | ∅ 6<br>6A | ∅ 6<br>6A | ∅ 6<br>6A | ∅ 6<br>6A | ∅ 6<br>6A | ∅ 6<br>6A | ∅ 6<br>6A | ∅ 6<br>6A | ∅ 6<br>6A | ∅ 6<br>6A |
| L        | NOT USED  | NOT USED  | NOT USED  | NOT USED  | NOT USED  | NOT USED  | NOT USED  | NOT USED  | NOT USED  | NOT USED  | NOT USED  | NOT USED  | NOT USED  | NOT USED  |

EX. : 1A, 2A, ETC. = LOOP NO.'S

FS = FLASH SENSE  
 ST = STOP TIME

### INPUT FILE CONNECTION & PROGRAMMING CHART

| LOOP NO. | LOOP TERMINAL | INPUT FILE POS. | PIN NO. | INPUT POINT | DETECTOR NO. | CALL PHASE | DELAY TIME | EXTEND TIME | EXTEND | ADDED INITIAL | CALL | DELAY DURING GREEN |
|----------|---------------|-----------------|---------|-------------|--------------|------------|------------|-------------|--------|---------------|------|--------------------|
| 1A       | TB2-1,2       | I1U             | 56      | 18          | 1 ★          | 1          | 15.0       |             | X      |               | X    |                    |
|          |               |                 |         | -           | 29 ★         | 6          | 3.0        |             | X      |               | X    | X                  |
| 1B       | TB2-5,6       | I2U             | 39      | 1           | 2            | 1          | 15.0       |             | X      | X             | X    |                    |
|          |               |                 |         | 2A          | TB2-9,10     | I3U        | 63         | 29          | 4      | 2             |      | X                  |
| 6A       | TB3-5,6       | J2U             | 40      | 2           | 16           | 6          |            |             | X      | X             | X    |                    |
| 8A       | TB5-9,10      | J6U             | 42      | 4           | 22           | 8          |            |             | X      |               | X    |                    |

★ For the detectors to work as shown on the signal design plan, see the Vehicle Detector Setup Programming Detail for Alternate Phasing on sheet 2.

### INPUT FILE POSITION LEGEND: J2L

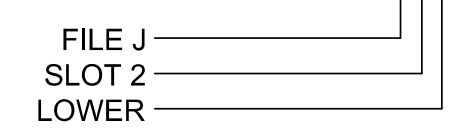

### LOAD RESISTOR INSTALLATION DETAIL

(install resistors as shown)

| Value (ohms) | Wattage   |
|--------------|-----------|
| 1.5K - 1.9K  | 25W (min) |
| 2.0K - 3.0K  | 10W (min) |

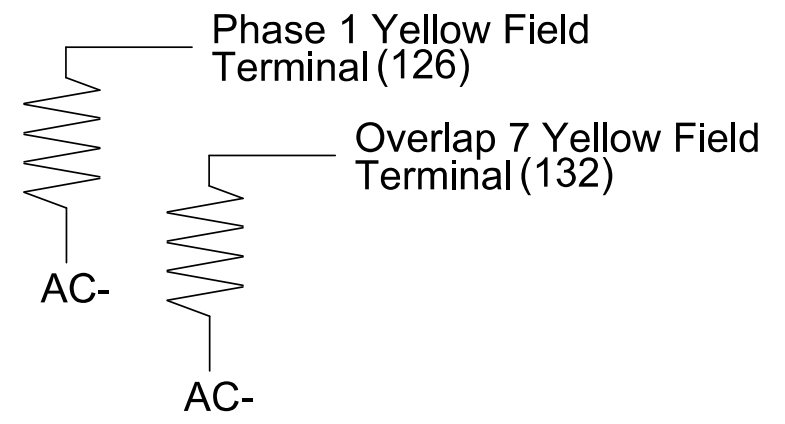

Electrical Detail Sheet 1 of 2

ELECTRICAL AND PROGRAMMING DETAILS FOR:

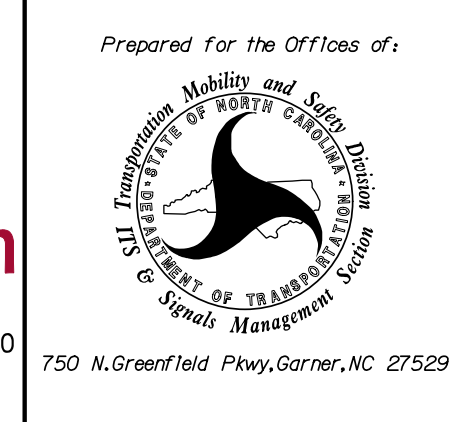

SR 2700 (Chatham Park Way)  
 at  
 US 64 EB Ramps

|                            |                         |           |
|----------------------------|-------------------------|-----------|
| Division 8                 | Chatham County          | Pittsboro |
| PLAN DATE: April 2024      | REVIEWED BY: KP Baumann |           |
| PREPARED BY: SP Pennington | REVIEWED BY:            |           |
| REVISIONS                  | INIT.                   | DATE      |

DOCUMENT NOT CONSIDERED FINAL UNLESS ALL SIGNATURES COMPLETED

SEAL

12/12/2024

SIG. INVENTORY NO. 08-0519

PLANS PREPARED IN THE OFFICE OF:  
**Kimley-Horn**  
 NC License #F-0102  
 421 Fayetteville Street, Suite 600  
 Raleigh, NC 27601  
 (919) 677-2000