

NOTES:
FOR NOTES SEE SHEET 1 OF 3.

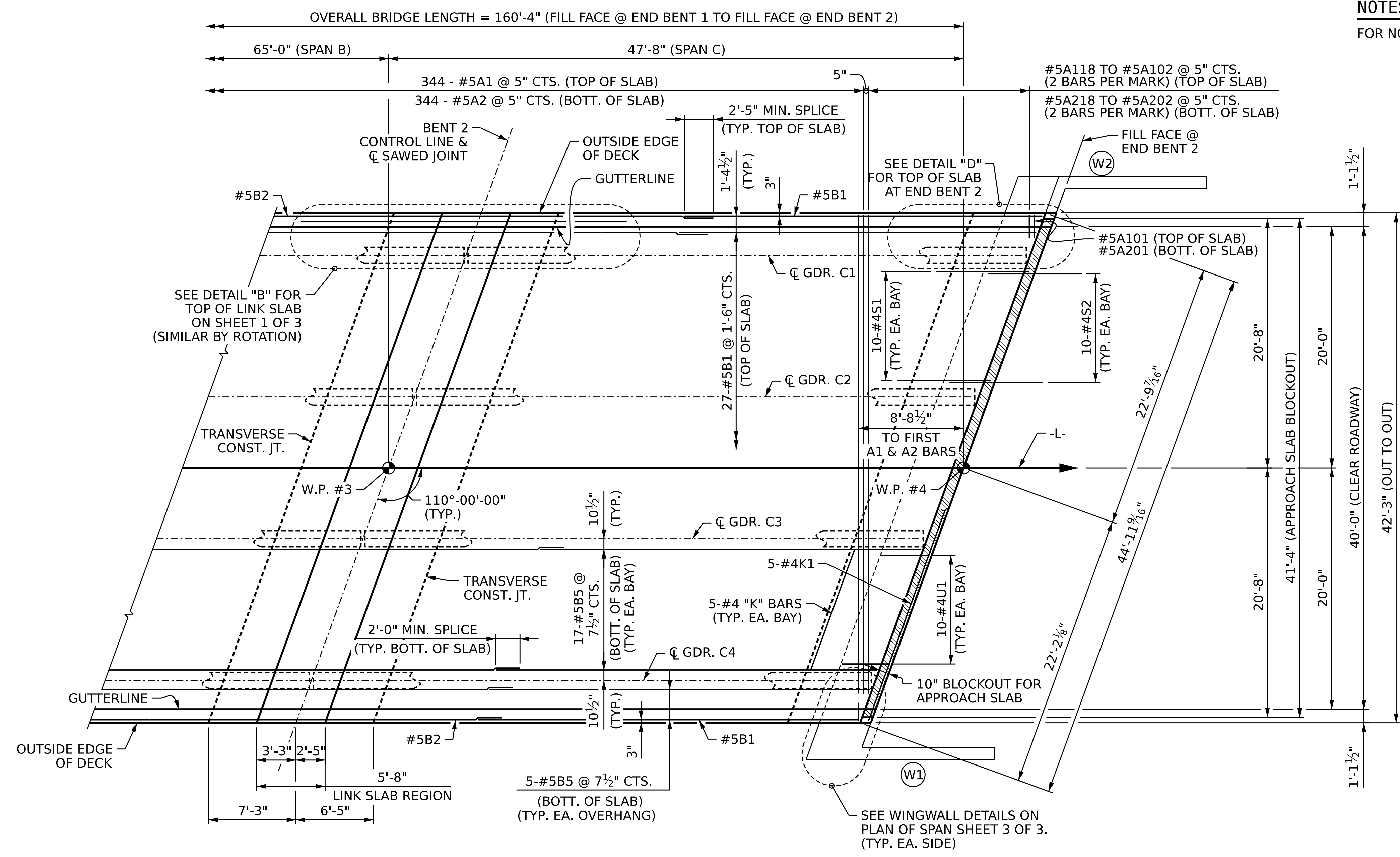

PLAN OF SPAN C

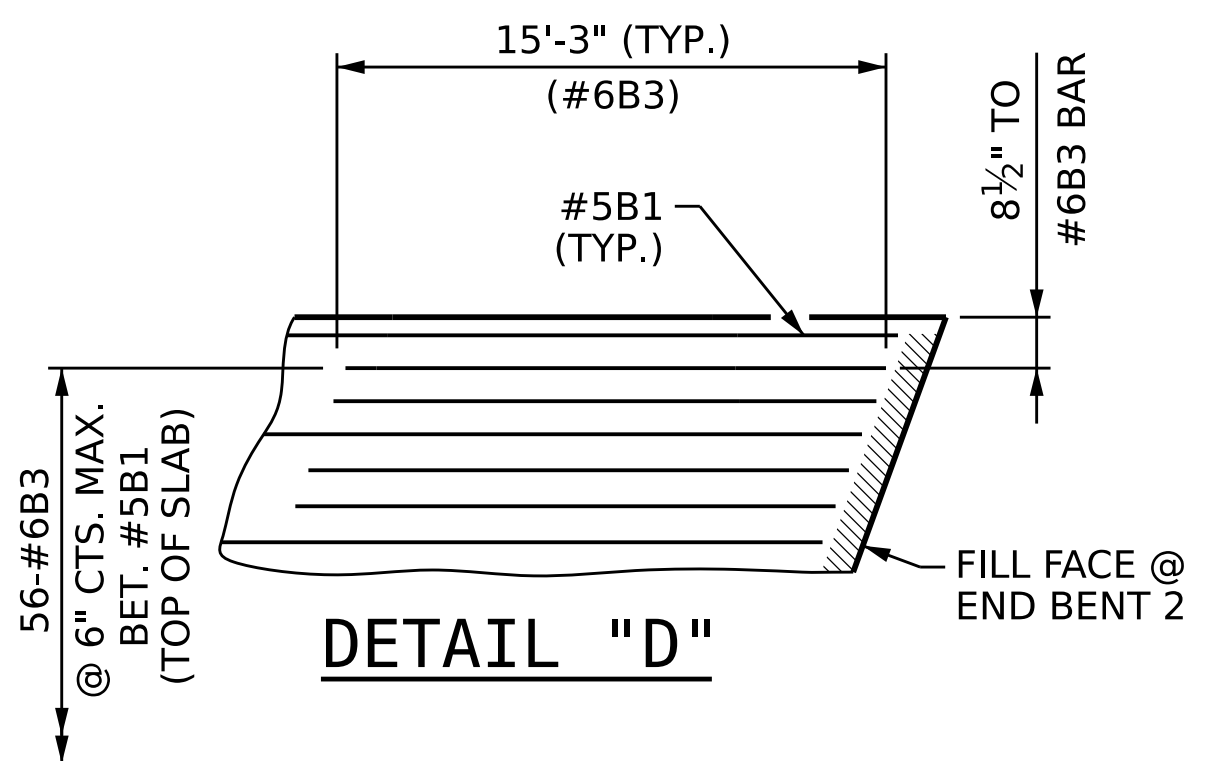

PROJECT NO. **BR-0100**

RUTHERFORD COUNTY

STATION: **18+28.00 -L-**

SHEET 2 OF 3

STATE OF NORTH CAROLINA
DEPARTMENT OF TRANSPORTATION
RALEIGH

**SUPERSTRUCTURE
PLAN OF SPAN C**

REVISIONS						SHEET NO. S-10 TOTAL SHEETS 30
NO.	BY:	DATE:	NO.	BY:	DATE:	
1			3			
2			4			

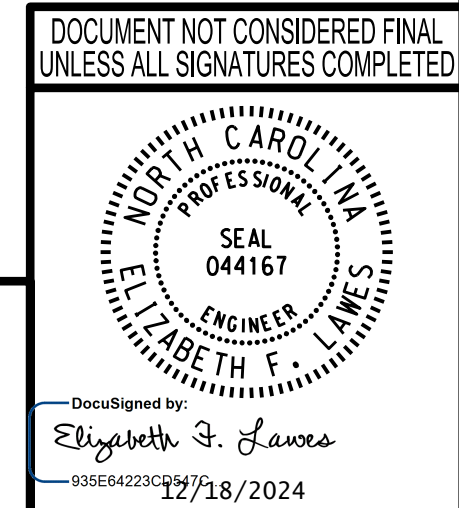

wsp

WSP USA Inc.
434 FAYETTEVILLE STREET
SUITE 1500
RALEIGH, NC 27601
TEL: 1.919.836.4040
LICENSE NO. F-0165

DESIGNED BY: J. WHEATLEY DATE: MAY 2024
DRAWN BY: M. HOBBS DATE: MAY 2024
CHECKED BY: E. LAWES DATE: MAY 2024
DESIGN ENGINEER OF RECORD: E. LAWES DATE: MAY 2024