

8/17/99

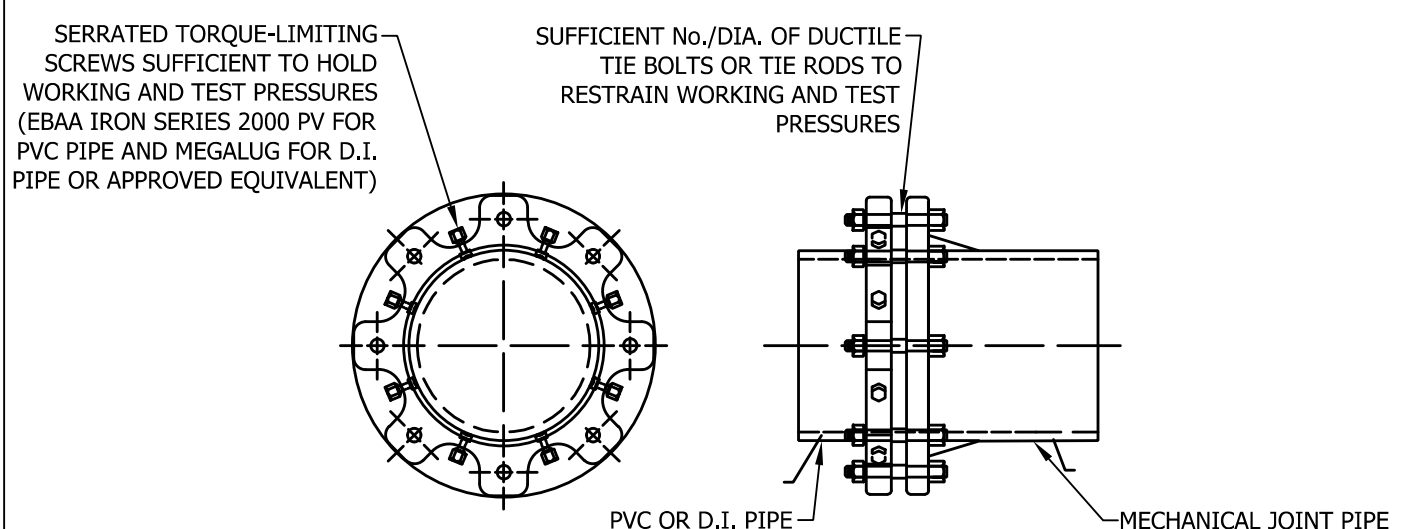

RESTRAINED JOINTS ON MECHANICAL JOINT PIPE & FITTINGS

MINIMUM FOOTAGE OF RESTRAINED PIPE FOR VARIOUS DIAMETERS & DEGREES CAST & DUCTILE IRON ELBOWS

COVER	DEGREE OF ELBOW						BRANCH OF TEE	REDUCER (LARGE SIDE ONLY)
	11.25°		22.5°		45°			
	UPPER BEND (3')	LOWER BEND (3')	UPPER BEND (3')	LOWER BEND (3')	UPPER BEND (3')	LOWER BEND (3')		
6"	3'	3'	3'	3'	3'	3'	3'	
8"	4'	5'	6'	10'	15'	15'	20'	
10"	4'	6'	14'	33'	25'	15'	30'	
12"	5'	8'	18'	42'	27'	18'	40'	
16"	5'	10'	20'	50'	30'	20'	45'	
20"	7'	13'	28'	67'	45'	30'	80'	
24"	8'	17'	35'	84'	55'	35'	105'	

RESTRAINED JOINT DETAIL

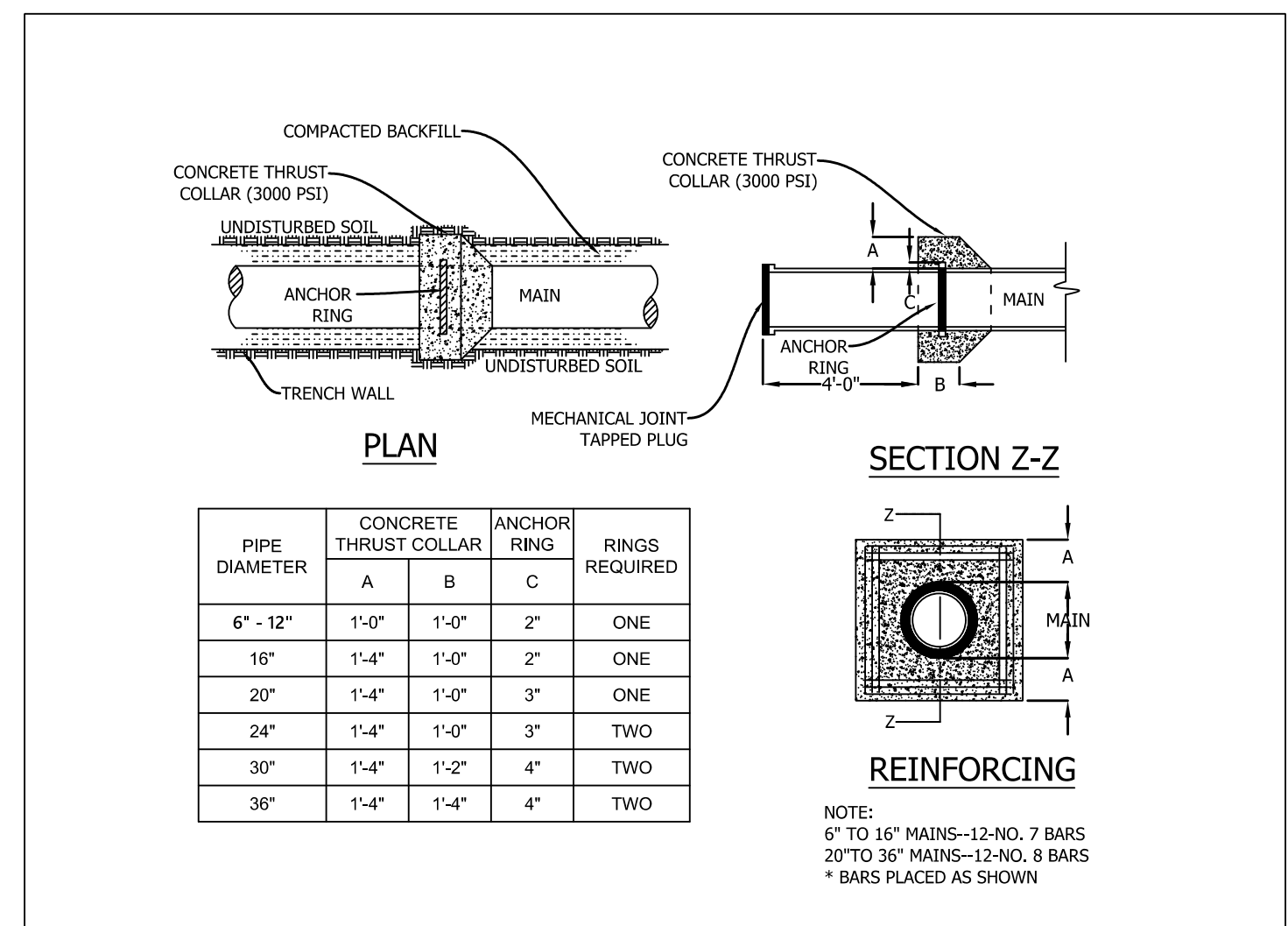

THRUST COLLAR INSTALLATION

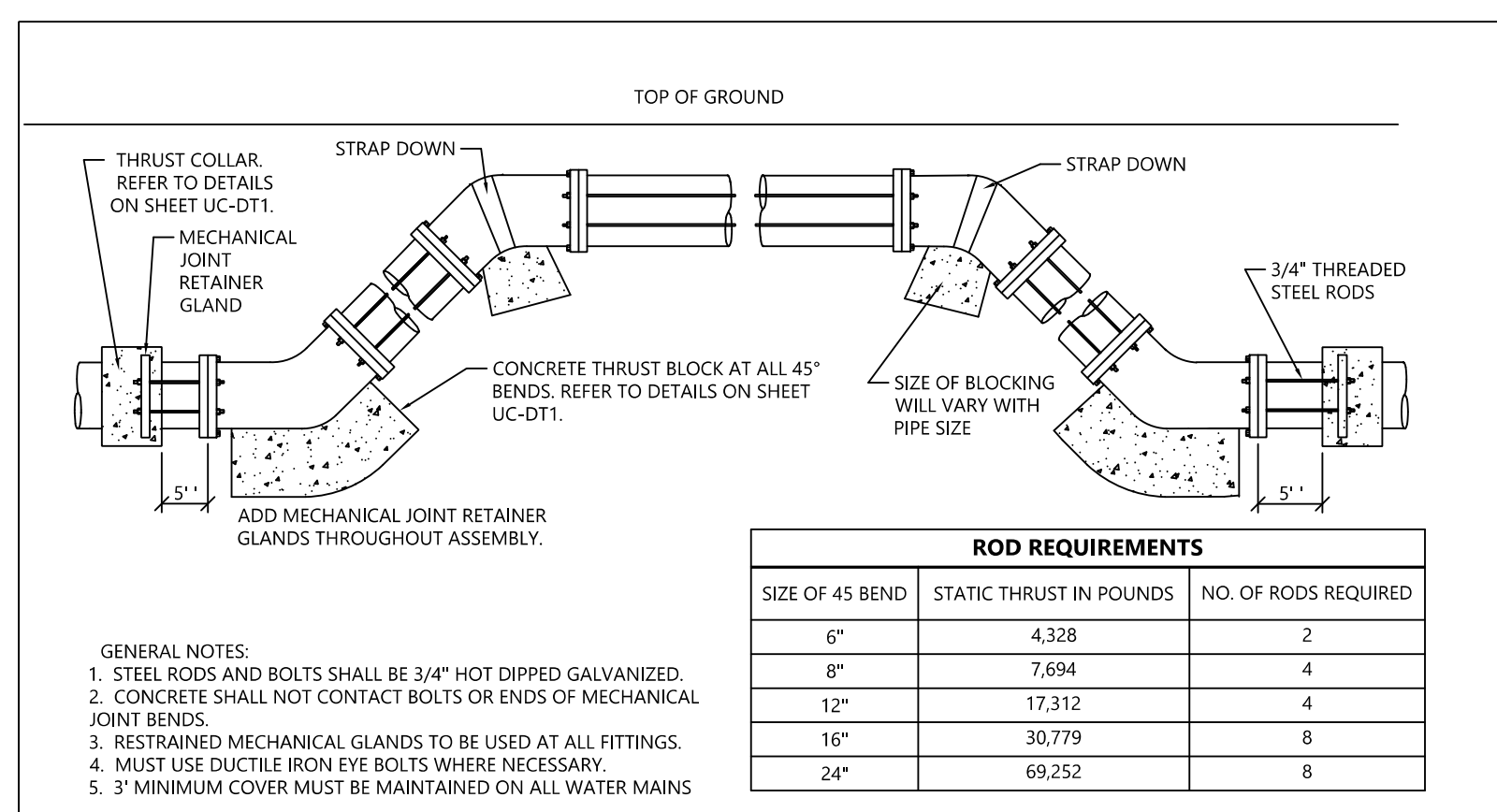

STANDARD VERTICAL BEND

ROD REQUIREMENTS

SIZE OF 45 BEND	STATIC THRUST IN POUNDS	NO. OF RODS REQUIRED
6"	4,328	2
8"	7,694	4
12"	17,312	4
16"	30,779	8
24"	69,252	8

- GENERAL NOTES:
- STEEL RODS AND BOLTS SHALL BE 3/4" HOT DIPPED GALVANIZED.
 - CONCRETE SHALL NOT CONTACT BOLTS OR ENDS OF MECHANICAL JOINT BENDS.
 - RESTRAINED MECHANICAL GLANDS TO BE USED AT ALL FITTINGS.
 - MUST USE DUCTILE IRON EYE BOLTS WHERE NECESSARY.
 - 3" MINIMUM COVER MUST BE MAINTAINED ON ALL WATER MAINS

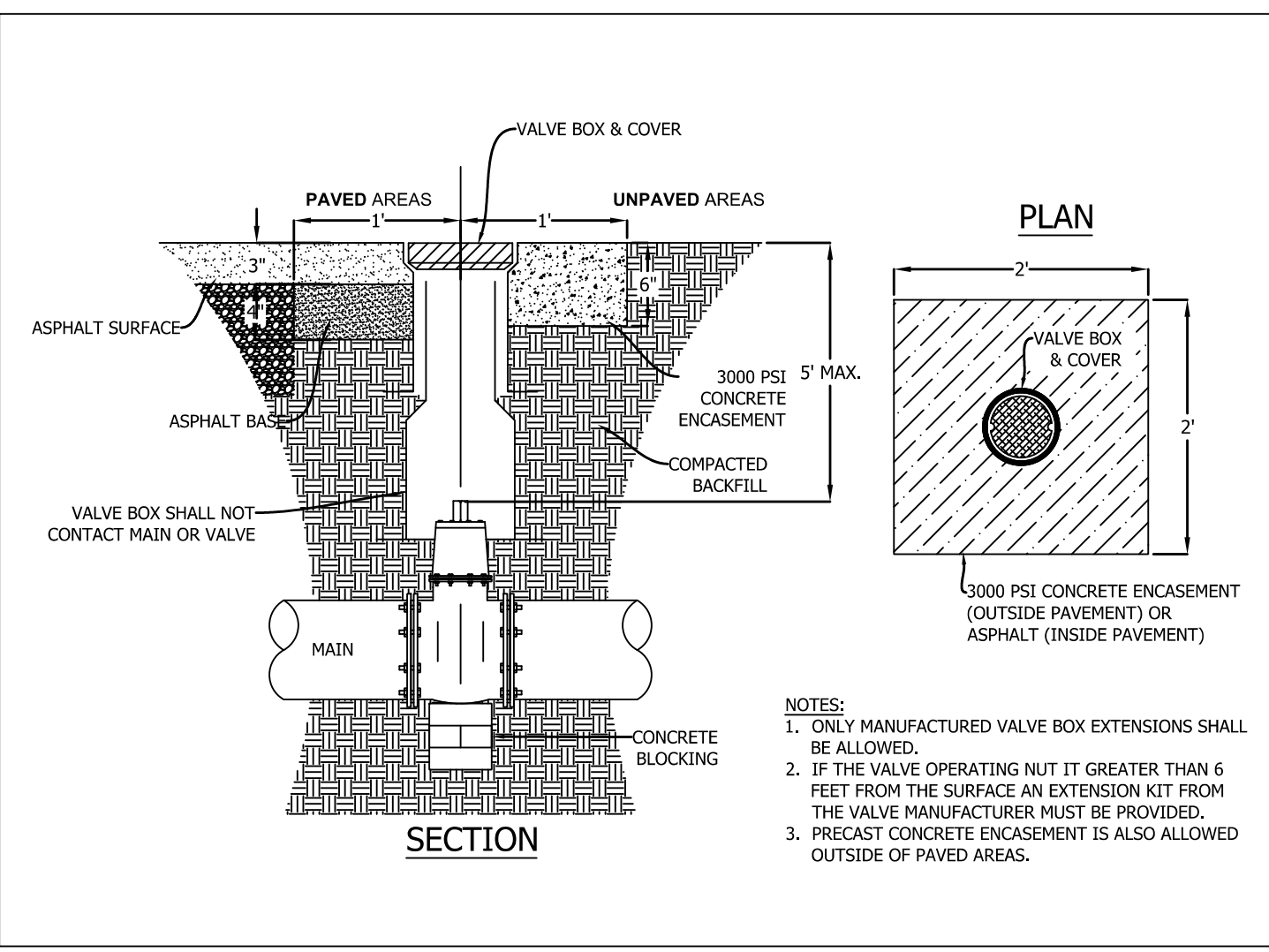

VALVE BOX INSTALLATION

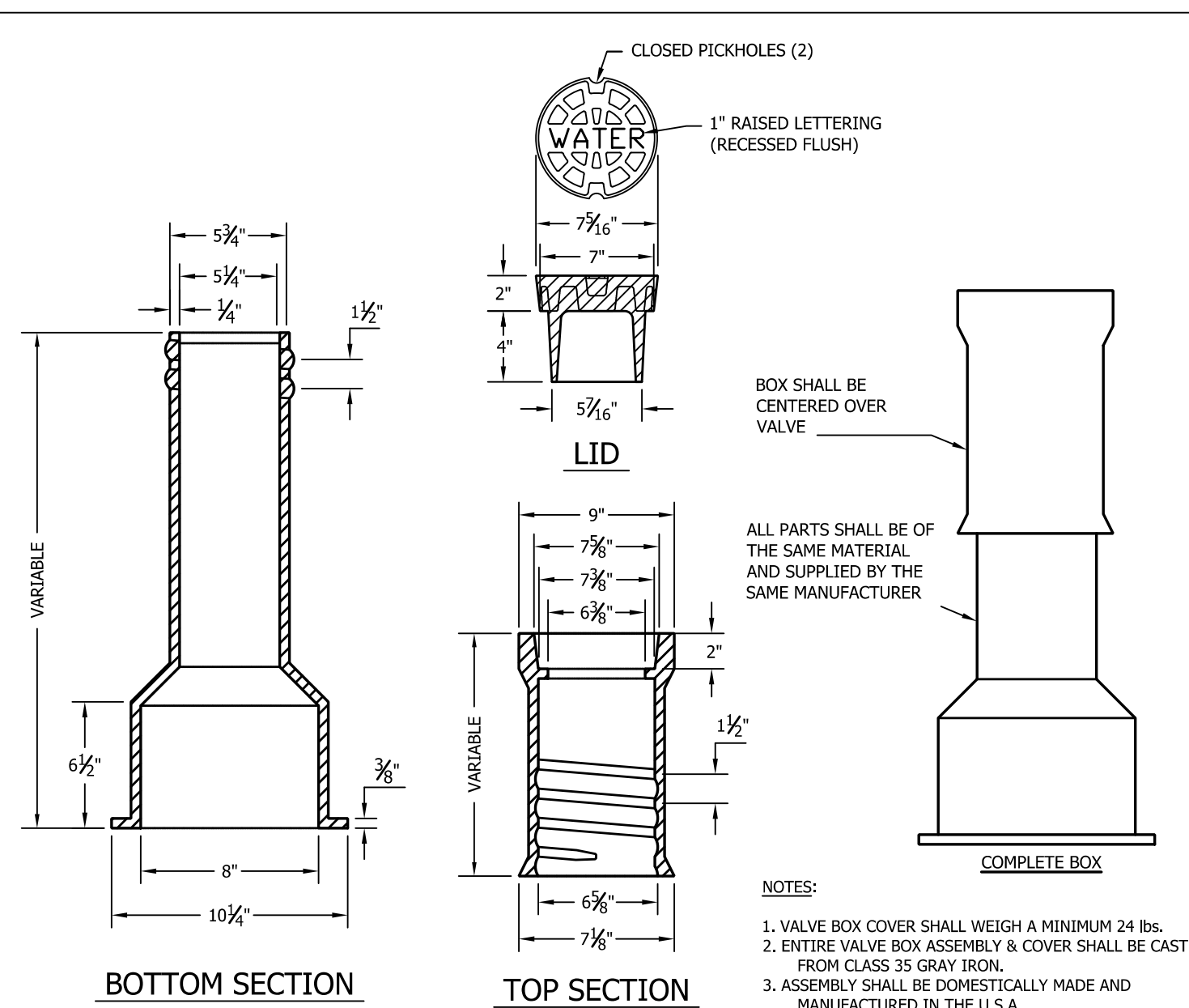

VALVE BOX INSTALLATION

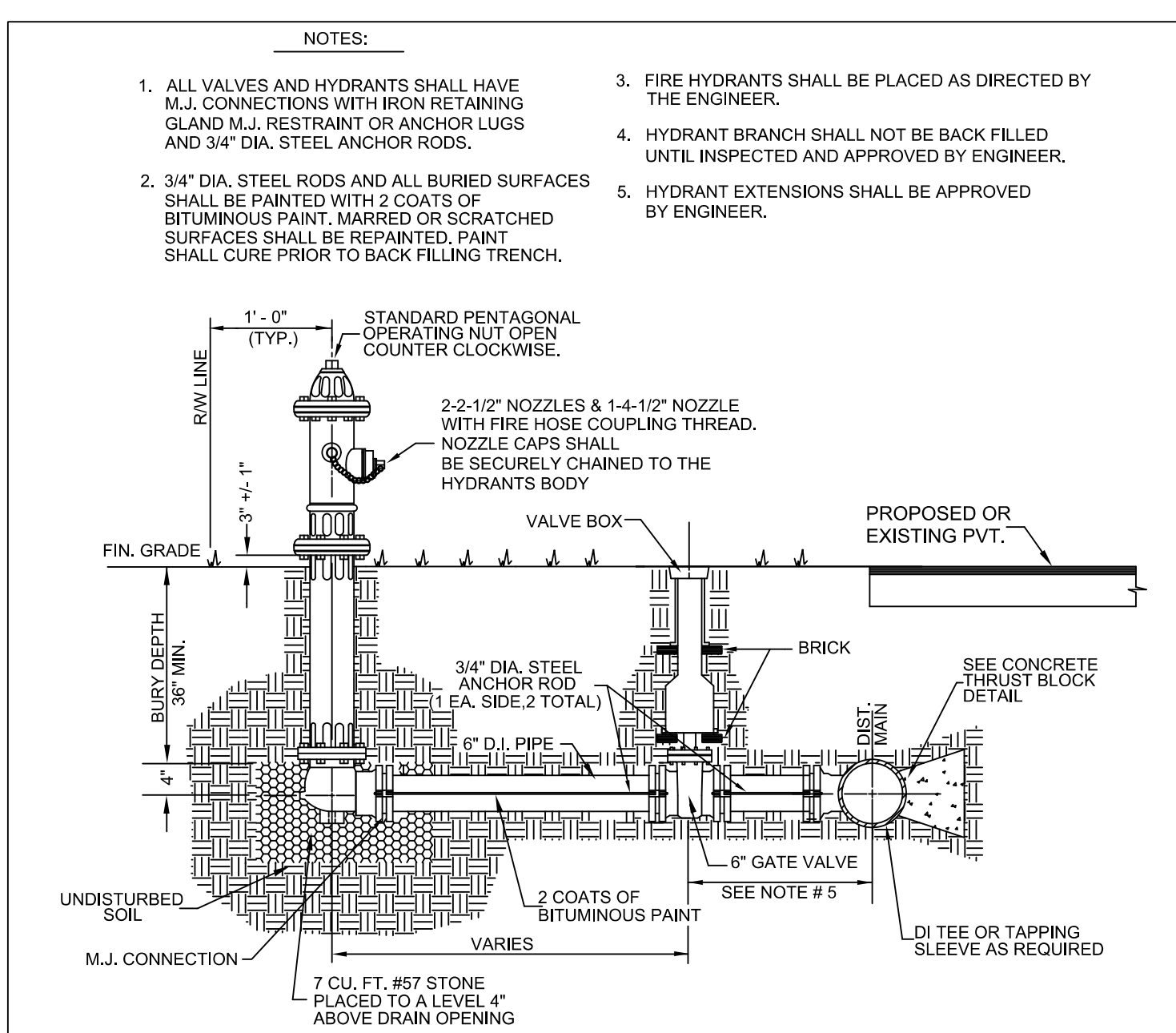

HYDRANT DETAIL

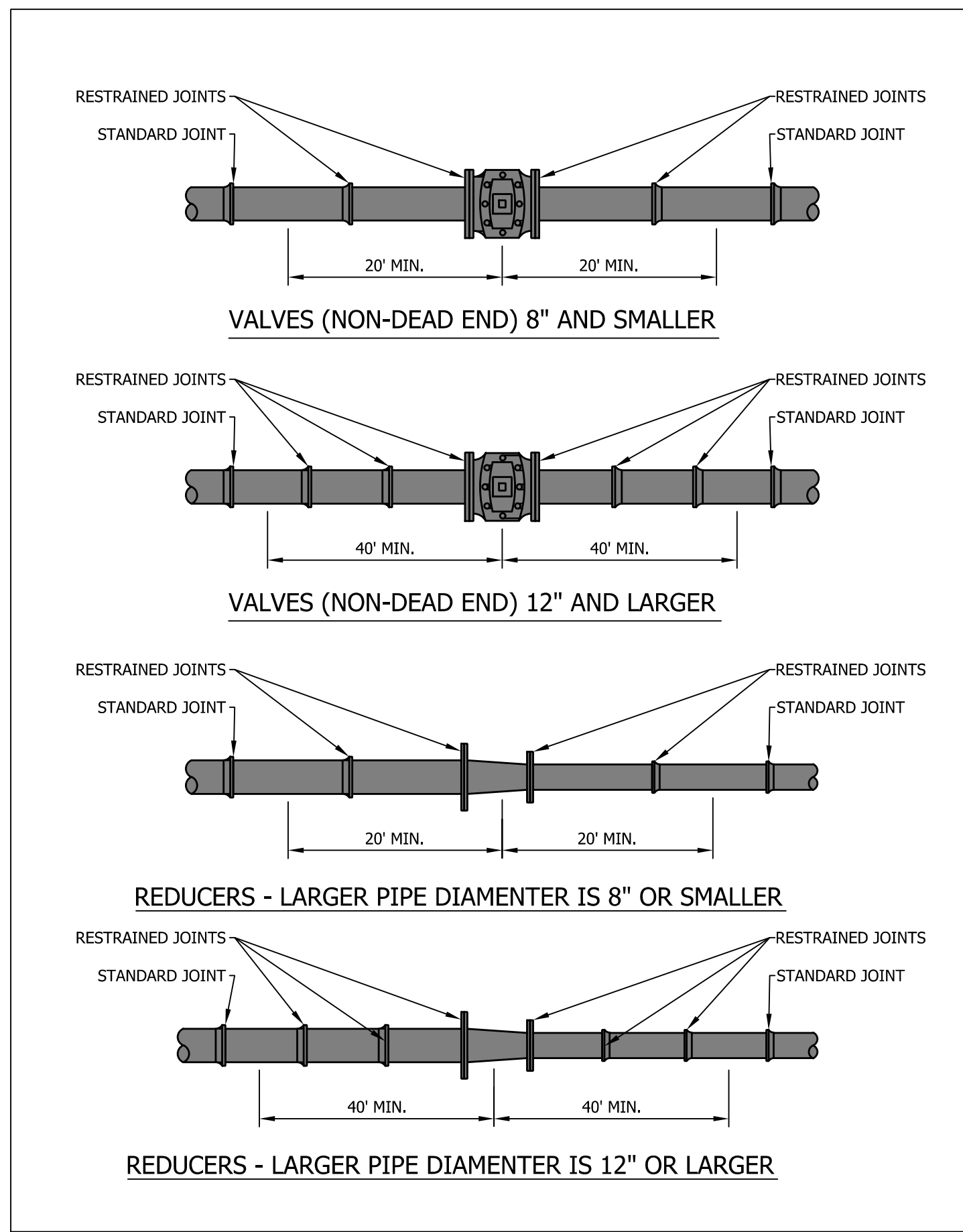

TYP. RESTRAINING FOR VALVES AND REDUCERS

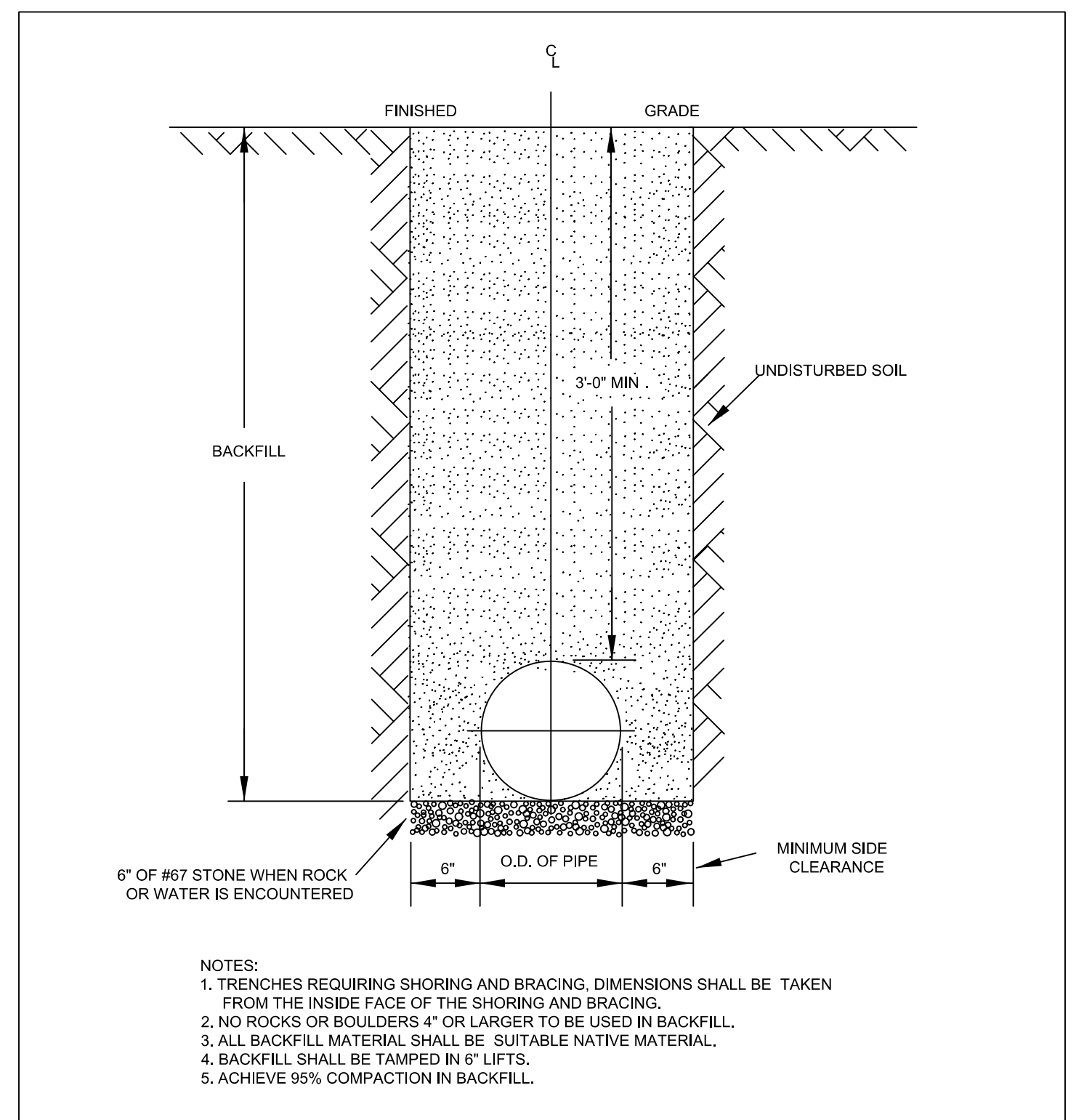

TRENCH BOTTOM & BACKFILLING REQUIREMENTS

- NOTES:
- TRENCHES REQUIRING SHORING AND BRACING, DIMENSIONS SHALL BE TAKEN FROM THE INSIDE FACE OF THE SHORING AND BRACING.
 - NO ROCKS OR BOULDERS 4" OR LARGER TO BE USED IN BACKFILL.
 - ALL BACKFILL MATERIAL SHALL BE SUITABLE NATIVE MATERIAL.
 - BACKFILL SHALL BE TAMPED IN 6" LIFTS.
 - ACHIEVE 95% COMPACTION IN BACKFILL.

PROJECT REFERENCE NO. 1-5979 SHEET NO. UC-2

RW SHEET NO.

WET UTILITIES ENGINEER 2/27/2024

SEAL 1470

JOHN M. KAWK

DOCUMENT NOT CONSIDERED FINAL UNLESS ALL SIGNATURES COMPLETED

Prepared by

vhb

VH8 Engineering N.C. P.C. (C-5705)
940 N. Main Street, Suite 100
Raleigh, NC 27608

R:\0442 AM R:\0442\Drawings\Proj\15979_UC_DETAIL.S.dgn