

# DETAILS

## PAVEMENT TIE-IN DETAIL

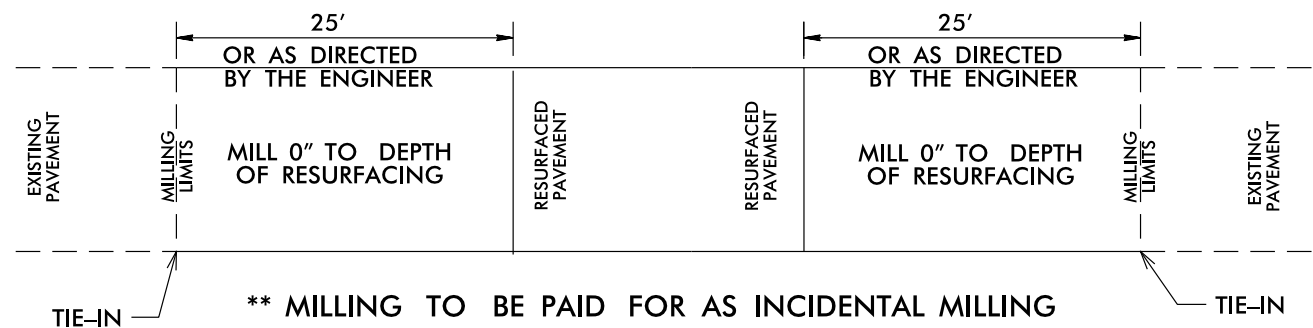

## DETAILS OF PATCHING EXISTING PAVEMENT PRIOR TO RESURFACING

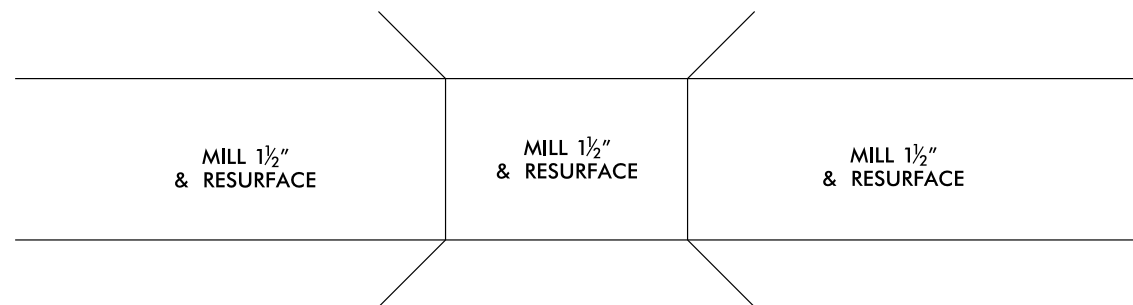
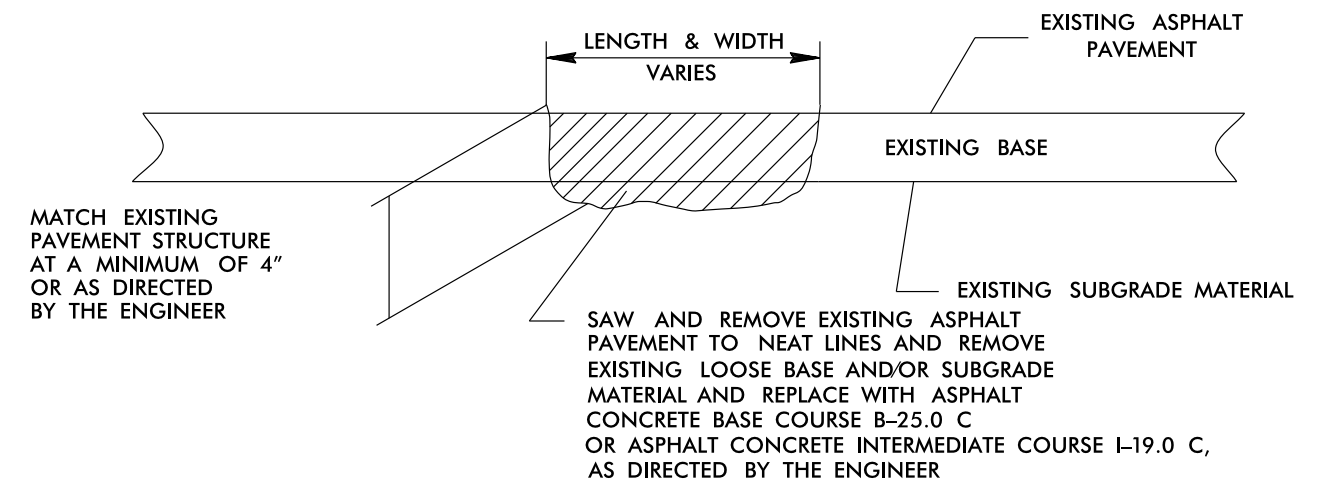

**BRIDGE DRAWING FOR  
MAP #1 NC 134 BRIDGE #13**

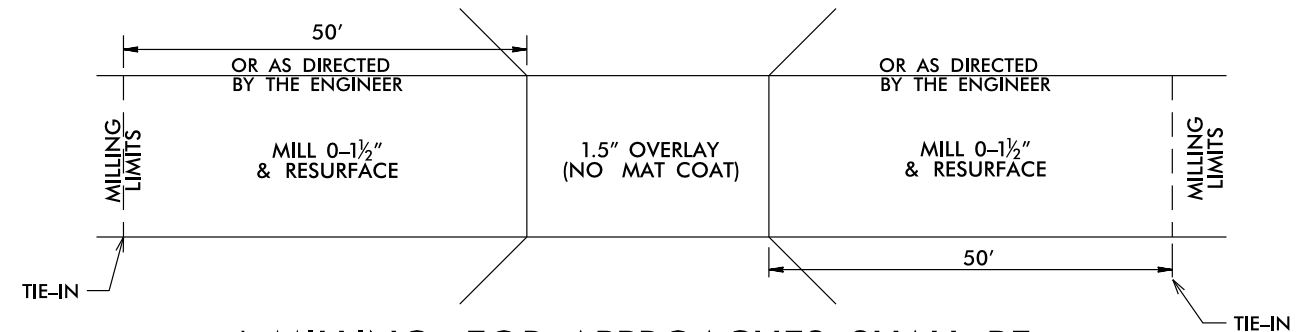

\* MILLING FOR APPROACHES SHALL BE PAID FOR UNDER INCIDENTAL MILLING

**BRIDGE DRAWING FOR  
MAP #4 SR 1541 BOWLES RD BRIDGE #55**