

DIVISION OF HIGHWAYS STATE OF NORTH CAROLINA

PROJECT REFERENCE NO. BR-0152	SHEET NO. EC-02
ROADWAY DESIGN ENGINEER	HYDRAULICS ENGINEER

EROSION & SEDIMENT CONTROL LEGEND

Std. #	Description	Symbol	Std. #	Description	Symbol
1605.01	Temporary Silt Fence		1633.01	Temporary Rock Silt Check Type A	
1606.01	Special Sediment Control Fence		1633.02	Temporary Rock Silt Check Type B	
1622.01	Temporary Berms and Slope Drains		1633.03	Temporary Rock Silt Check Type A with Excelsior Matting and Flocculant	
1630.02	Silt Basin Type B		1634.01	Temporary Rock Sediment Dam Type A	
1630.03	Temporary Silt Ditch		1634.02	Temporary Rock Sediment Dam Type B	
1630.04	Stilling Basin		1635.01	Rock Pipe Inlet Sediment Trap Type A	
1630.05	Temporary Diversion		1635.02	Rock Pipe Inlet Sediment Trap Type B	
1630.06	Special Stilling Basin		1636.01	Excelsior Wattle Check	
1630.07	Skimmer Basin		1636.01	Excelsior Wattle Check with Flocculant	
1630.08	Tiered Skimmer Basin		1636.01	Coir Fiber Wattle Check	
1630.09	Earthen Dam with Skimmer		1636.01	Coir Fiber Wattle Check with Flocculant	
	Infiltration Basin		1636.02	Silt Fence Excelsior Wattle Break	
	Rock Inlet Sediment Trap:			Silt Fence Coir Fiber Wattle Break	
1632.01	Type A		1636.02	Excelsior Wattle Barrier	
1632.02	Type B		1636.03	Coir Fiber Wattle Barrier	
1632.03	Type C				

PROJECT REFERENCE NO. <i>BR-0152</i>	SHEET NO. <i>EC-02A</i>
RW SHEET NO.	
ROADWAY DESIGN ENGINEER	HYDRAULICS ENGINEER

ONSITE CONCRETE WASHOUT STRUCTURE WITH LINER

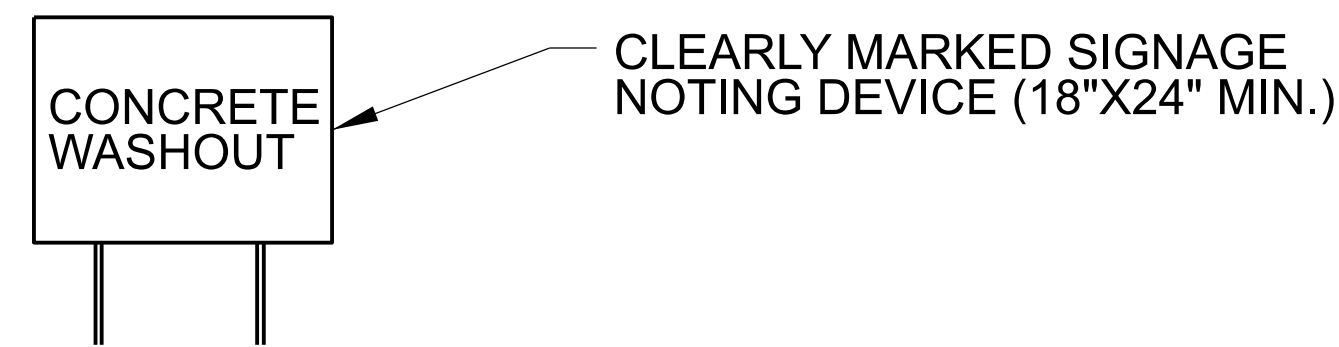
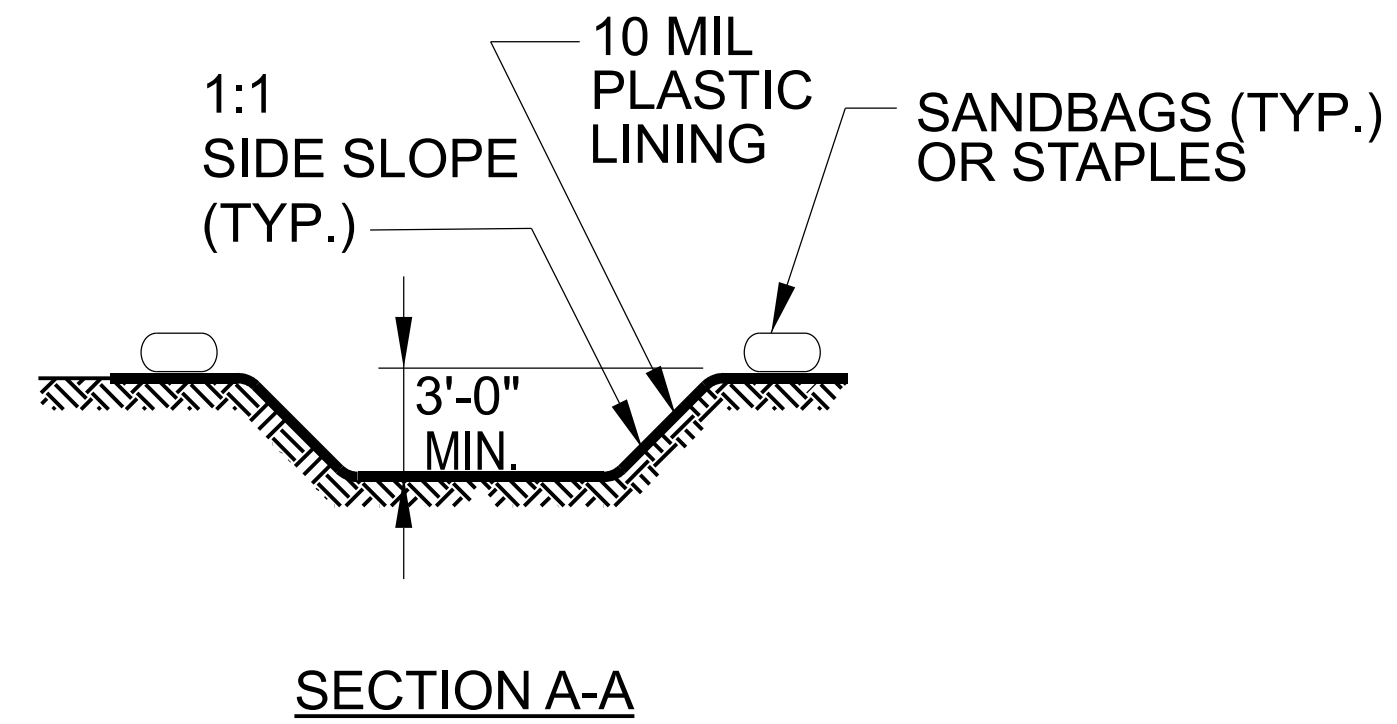
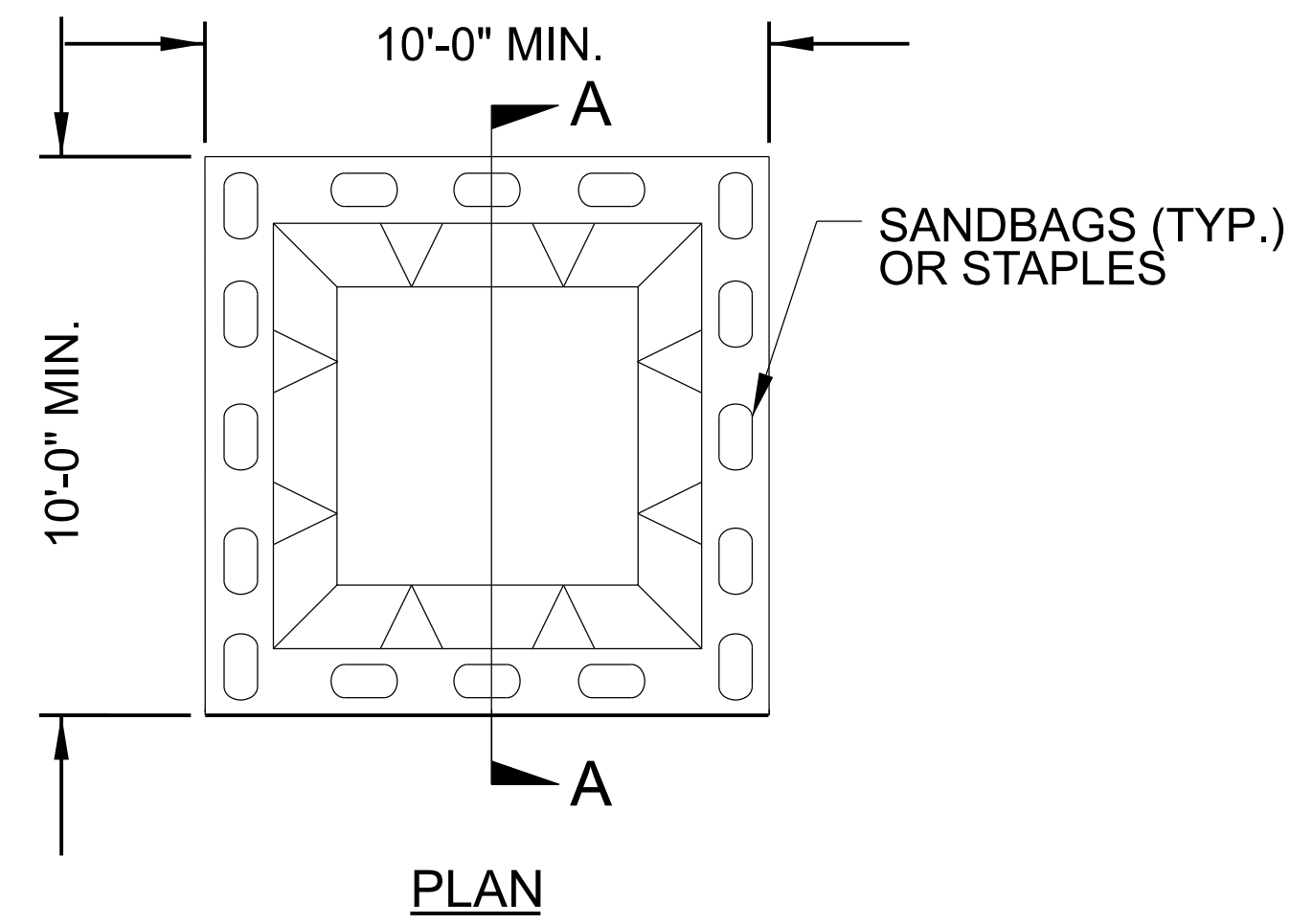

BELOW GRADE WASHOUT STRUCTURE
NOT TO SCALE

- NOTES:**
1. ACTUAL LOCATION DETERMINED IN FIELD
 2. THE CONCRETE WASHOUT STRUCTURES SHALL BE MAINTAINED WHEN THE LIQUID AND/OR SOLID REACHES 75% OF THE STRUCTURES CAPACITY TO PROVIDE ADEQUATE HOLDING CAPACITY WITH A MINIMUM 12 INCHES OF FREEBOARD.
 3. CONCRETE WASHOUT STRUCTURE NEEDS TO BE CLEARLY MARKED WITH SIGNAGE NOTING DEVICE.

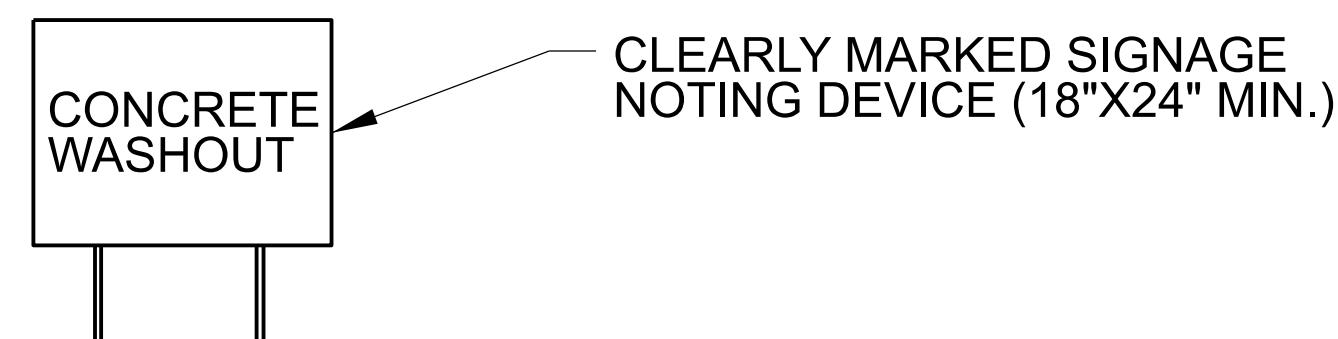
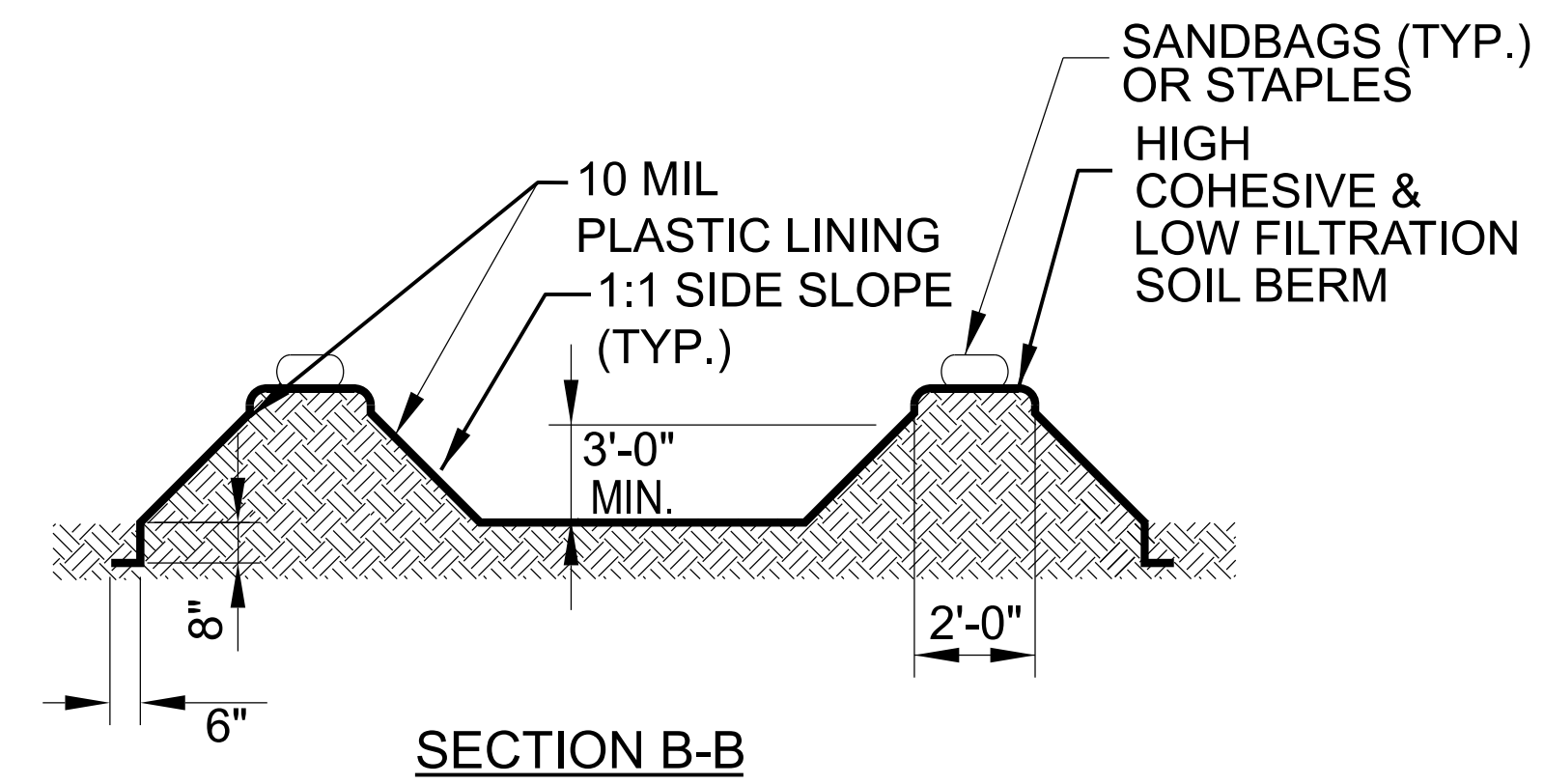
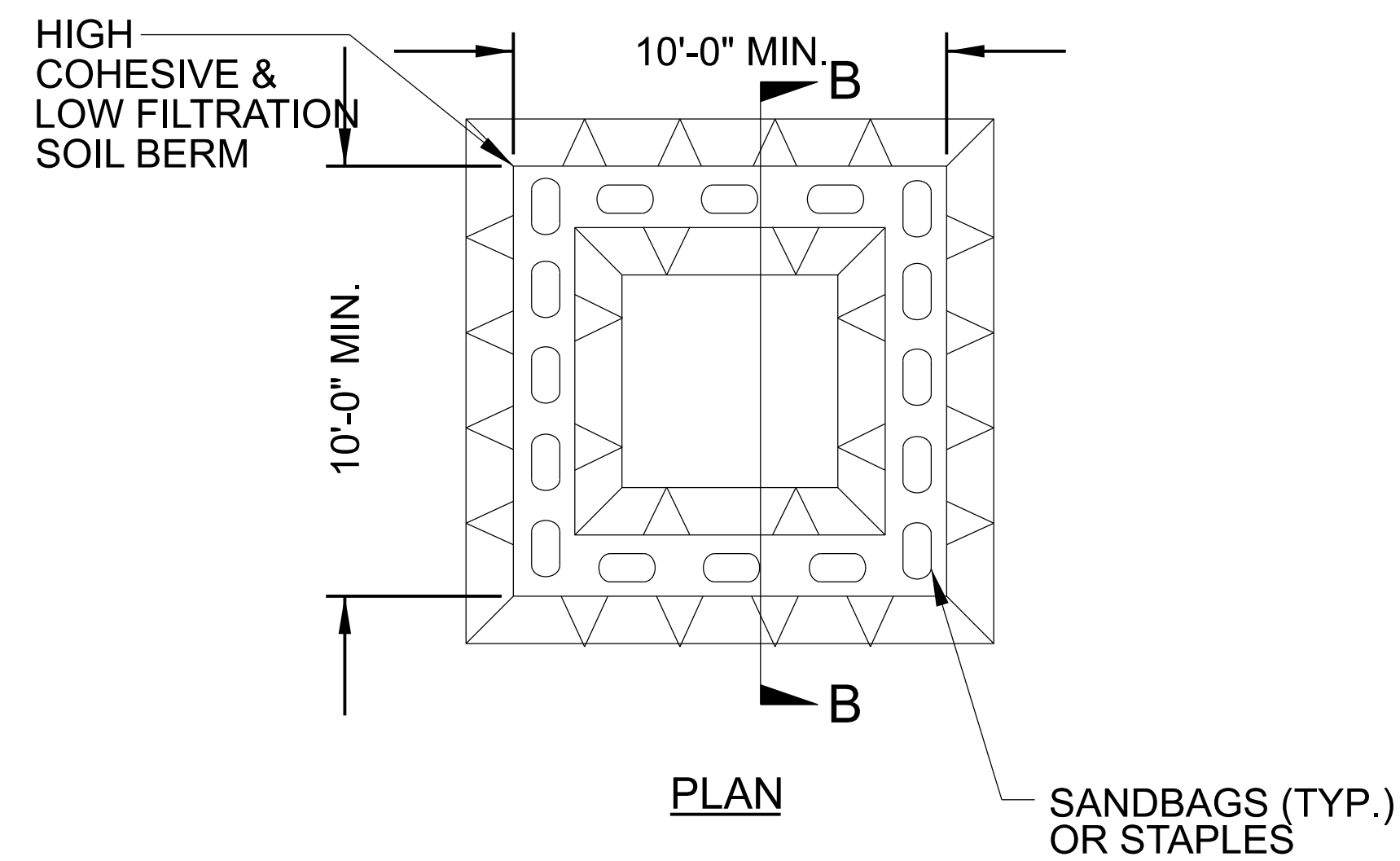

ABOVE GRADE WASHOUT STRUCTURE
NOT TO SCALE

- NOTES:**
1. ACTUAL LOCATION DETERMINED IN FIELD
 2. THE CONCRETE WASHOUT STRUCTURES SHALL BE MAINTAINED WHEN THE LIQUID AND/OR SOLID REACHES 75% OF THE STRUCTURES CAPACITY TO PROVIDE ADEQUATE HOLDING CAPACITY WITH A MINIMUM 12 INCHES OF FREEBOARD.
 3. CONCRETE WASHOUT STRUCTURE NEEDS TO BE CLEARLY MARKED WITH SIGNAGE NOTING DEVICE.

DIVISION OF HIGHWAYS
STATE OF NORTH CAROLINA

PROJECT REFERENCE NO. <i>BR-0152</i>	SHEET NO. <i>EC-3A</i>
ROADWAY DESIGN ENGINEER	HYDRAULICS ENGINEER

SOIL STABILIZATION TIMEFRAMES

<i>SITE DESCRIPTION</i>	<i>STABILIZATION TIME</i>	<i>TIMEFRAME EXCEPTIONS</i>
PERIMETER DIKES, SWALES, DITCHES AND SLOPES	7 DAYS	NONE
HIGH QUALITY WATER (HQW) ZONES	7 DAYS	NONE
SLOPES STEEPER THAN 3:1	7 DAYS	IF SLOPES ARE 10' OR LESS IN LENGTH AND ARE NOT STEEPER THAN 2:1, 14 DAYS ARE ALLOWED.
SLOPES 3:1 TO 4:1	14 DAYS	7 DAYS FOR SLOPES GREATER THAN 50' IN LENGTH WITH SLOPES STEEPER THAN 4:1. 7 DAYS FOR PERIMETER DIKES, SWALES, DITCHES PERIMETER SLOPES, AND HQW ZONES
ALL OTHER AREAS WITH SLOPES FLATTER THAN 4:1	14 DAYS	7 DAYS FOR PERIMETER DIKES, SWALES, DITCHES PERIMETER SLOPES, AND HQW ZONES

NOTE: UTILIZE FABRIC INSERT INLET PROTECTION IN LIEU OF TYPE C INLET PROTECTION WHERE WATER MIGHT POND ON ROADWAY USED BY PUBLIC TRAFFIC.

Place Matting for Erosion Control on Slope as Work Allows.
-Y- Sta. 15+69 to Sta. 17+13 LT
-Y- Sta. 17+50 to Sta. 18+86 LT
-Y- Sta. 15+17 to Sta. 16+49 RT
-Y- Sta. 16+92 to Sta. 18+31 RT

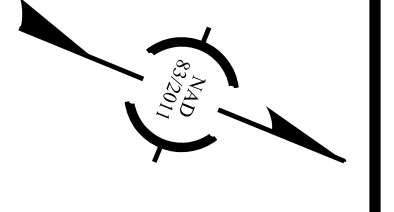
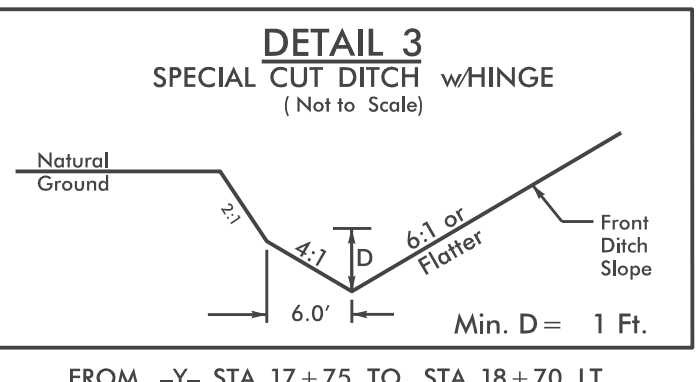
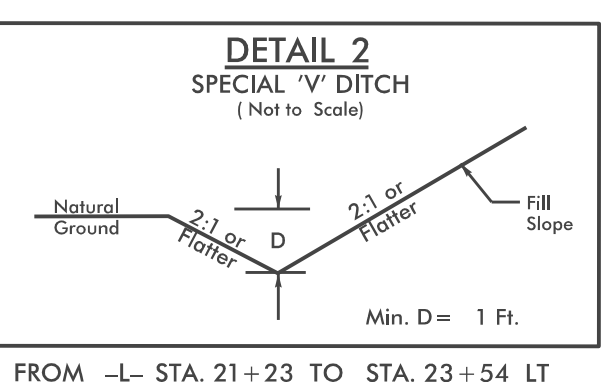
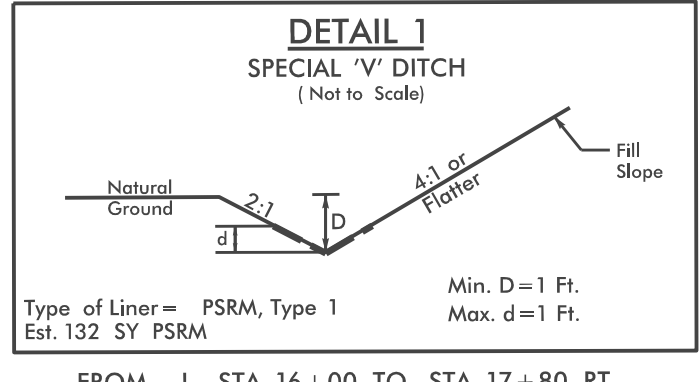
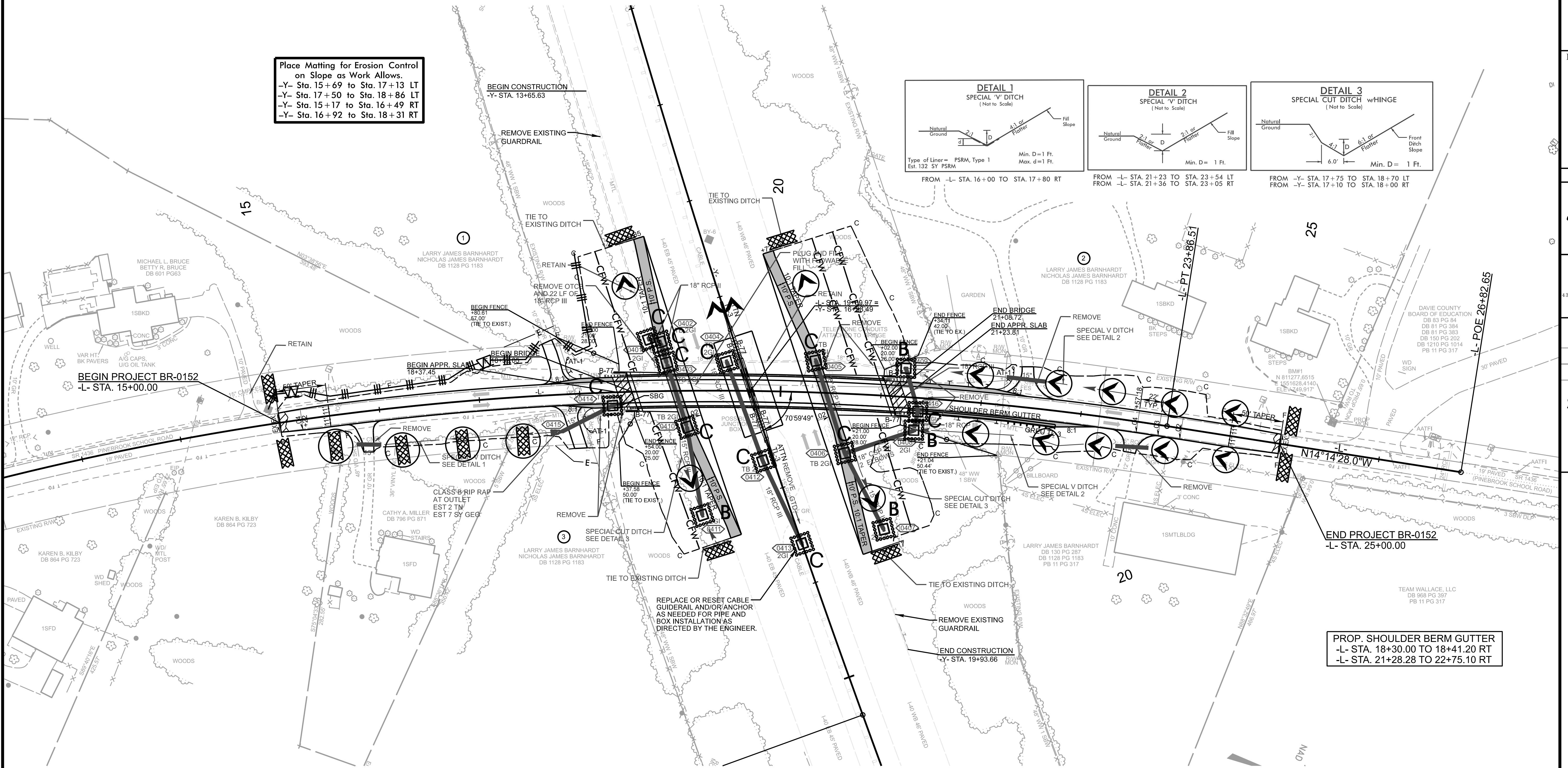

PROP. SHOULDER BERM GUTTER
-L- STA. 18+30.00 TO 18+41.20 RT
-L- STA. 21+28.28 TO 22+75.10 RT