



LOCATION SKETCH

INFORMATION INDICATED ON THE LOCATION SKETCH SHALL BE CONSIDERED GENERAL INFORMATION ONLY. CONTRACTOR SHALL CONFIRM, THROUGH OTHER SOURCES, SPECIFIC INFORMATION REGARDING BRIDGES, ROADWAY, UTILITIES, THE SURROUNDING AREA, AND ANY OTHER ASPECTS THAT MAY BE NECESSARY TO PERFORM AND COMPLETE THE PROJECT.

BRIDGE COORDINATES	
LATITUDE	LONGITUDE
34°-19'-21.22"	78°-28'-03.20"

GENERAL NOTES

SEE CONTRACT DOCUMENTS FOR LANE WIDTHS, SEQUENCING AND OTHER TRAFFIC CONTROL MEASURES FOR STAGING OF OVERLAY SURFACE PREPARATION AND POLYMER CONCRETE (PC) PLACEMENT.

THE CONTRACTOR'S ATTENTION IS CALLED TO THE FACT THAT DUE TO THE NATURE OF PRESERVATION PROJECTS, THE EXTENT OF WORK CANNOT ALWAYS BE ACCURATELY DETERMINED PRIOR TO COMMENCEMENT OF WORK. REPAIR LOCATIONS AND ESTIMATES OF QUANTITIES ARE GIVEN WITH THE BEST INFORMATION AVAILABLE. IF ADDITIONAL REPAIRS NOT SHOWN ON THE DRAWINGS ARE DEEMED NECESSARY BY THE ENGINEER, THE ENGINEER SHALL NOTE ON THE DRAWINGS THE APPROXIMATE LOCATION AND DESCRIPTION OF THE REPAIR.

EXISTING DIMENSIONS AND BRIDGE CONDITION ARE FROM THE BEST INFORMATION AVAILABLE. THE CONTRACTOR SHALL FIELD VERIFY THE INFORMATION SHOWN ON THE PLANS AND NOTIFY THE ENGINEER IF ACTUAL DIMENSIONS AND CONDITIONS DIFFER.

THE CONTRACTOR SHALL HAVE NO CLAIM WHATSOEVER AGAINST THE DEPARTMENT FOR ANY DELAYS OR ADDITIONAL COST INCURRED BASED ON DIFFERENCES BETWEEN WHAT IS SHOWN ON THE PLANS AND THE ACTUAL CONDITIONS AT THE PROJECT SITE.

IT IS THE CONTRACTOR'S RESPONSIBILITY TO FOLLOW ALL STATE AND FEDERAL SAFETY REQUIREMENTS.

WORK ON THE BRIDGE SHALL BE PERFORMED SO AS NOT TO ALLOW DEBRIS TO FALL BELOW, EXCEPT WHERE THE CONTRACTOR'S PLAN USED PLATFORMS, NETS, SCREEN OR OTHER PROTECTIVE DEVICES TO CATCH THE MATERIAL. THE CONTRACTOR SHALL SUBMIT PLANS FOR CONSTRUCTION IN ACCORDANCE WITH ARTICLE 402-2 OF THE STANDARD SPECIFICATIONS AND THE PROJECT SPECIAL PROVISIONS. ANY DAMAGE TO EXISTING REINFORCING STEEL DURING CONTRACTOR'S OPERATIONS SHALL BE REPAIRED AS DIRECTED BY THE ENGINEER AND PERFORMED AT NO ADDITIONAL COST TO THE DEPARTMENT.

FOR CONTROL OF TRAFFIC AND LIMITS OF PHASING OF CONSTRUCTION, SEE CONTRACT DOCUMENTS.

PRIOR TO BEGINNING WORK, THE CONTRACTOR SHALL SUBMIT FOR REVIEW AND APPROVAL A COMPLETE SEQUENCE OF TASKS FOR EACH OPERATION AFFECTING THE BRIDGE SURFACE AND/OR TRAFFIC.

FOR OTHER DESIGN DATA AND GENERAL NOTES, SEE SHEET SN.

FOR FALSEWORK AND FORMWORK, SEE SPECIAL PROVISIONS.

FOR SUBMITTAL OF WORKING DRAWINGS, SEE SPECIAL PROVISIONS.

FOR CRANE SAFETY, SEE SPECIAL PROVISIONS.

FOR GROUT FOR STRUCTURES, SEE SPECIAL PROVISIONS.

ALL PAVEMENT MARKING WILL BE IN ACCORDANCE WITH THE CONTRACT DOCUMENTS.

EXISTING JOINTS AND DECK DRAINS SHALL BE SEALED PRIOR TO BEGINNING SURFACE PREPARATIONS OF THE BRIDGE DECK. THE CONTRACTOR SHALL TAKE CARE THAT ANY CONSTRUCTION DEBRIS THAT COLLECTS IN THE DRAINS IS CONTAINED. DRAINS IN SHOULDERS OF ADJACENT TRAVEL LANES SHALL BE KEPT FREE AND CLEAR OF DEBRIS.

LONGITUDINAL CONSTRUCTION JOINTS OF OVERLAYS SHALL BE LOCATED ALONG THE CENTERLINE OR EDGE OF TRAVEL LANES.

FOR CLASS 1B SURFACE PREPARATION, SEE BRIDGE DECK ASPHALT OVERLAY SPECIAL PROVISION.

FOR ASPHALT PLUG JOINTS FOR PRESERVATION, SEE SPECIAL PROVISIONS.

FOR PILE ENCAPSULATION, SEE SPECIAL PROVISIONS.

FOR BRIDGE DECK WATERPROOFING MEMBRANE-SPRAY APPLIED, SEE SPECIAL PROVISIONS.

PROJECT NO. **HI-0018**
COLUMBUS COUNTY
 BRIDGE NO. **230385**

SHEET 2 OF 2

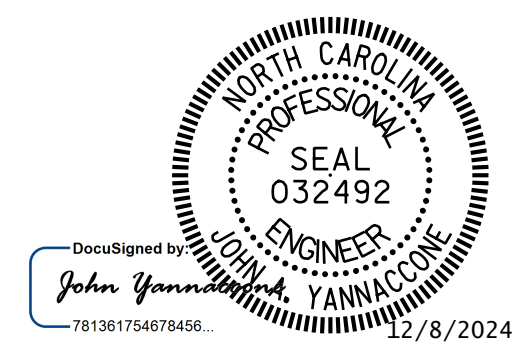

STATE OF NORTH CAROLINA
 DEPARTMENT OF TRANSPORTATION
 RALEIGH

GENERAL DRAWING
 FOR BRIDGE ON
 US 74 - US 76 BYP WBL
 OVER FRIAR SWAMP

DRAWN BY : **R.L.PUTEK** DATE : **08/2024**
 CHECKED BY : **J.A.YANNACCONE** DATE : **08/2024**



DOCUMENT NOT CONSIDERED FINAL UNLESS ALL SIGNATURES COMPLETED	REVISIONS						SHEET NO. S7-02 TOTAL SHEETS 79
	NO.	BY:	DATE:	NO.	BY:	DATE:	
	1			3			
	2			4			

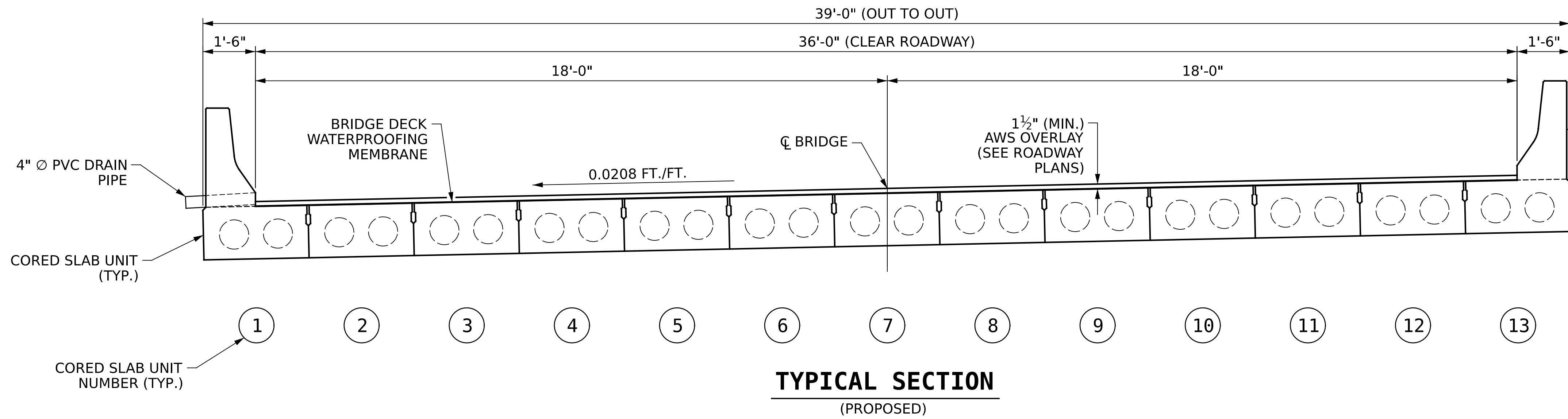

NOTES:
 SEE CONTRACT DOCUMENTS FOR LANE WIDTHS, SEQUENCING AND OTHER TRAFFIC CONTROL MEASURES FOR STAGING OF OVERLAY SURFACE PREPARATION AND ASPHALT OVERLAY.
 FOR BRIDGE DECK WATERPROOFING MEMBRANE-SPRAY APPLIED, SEE SPECIAL PROVISIONS.

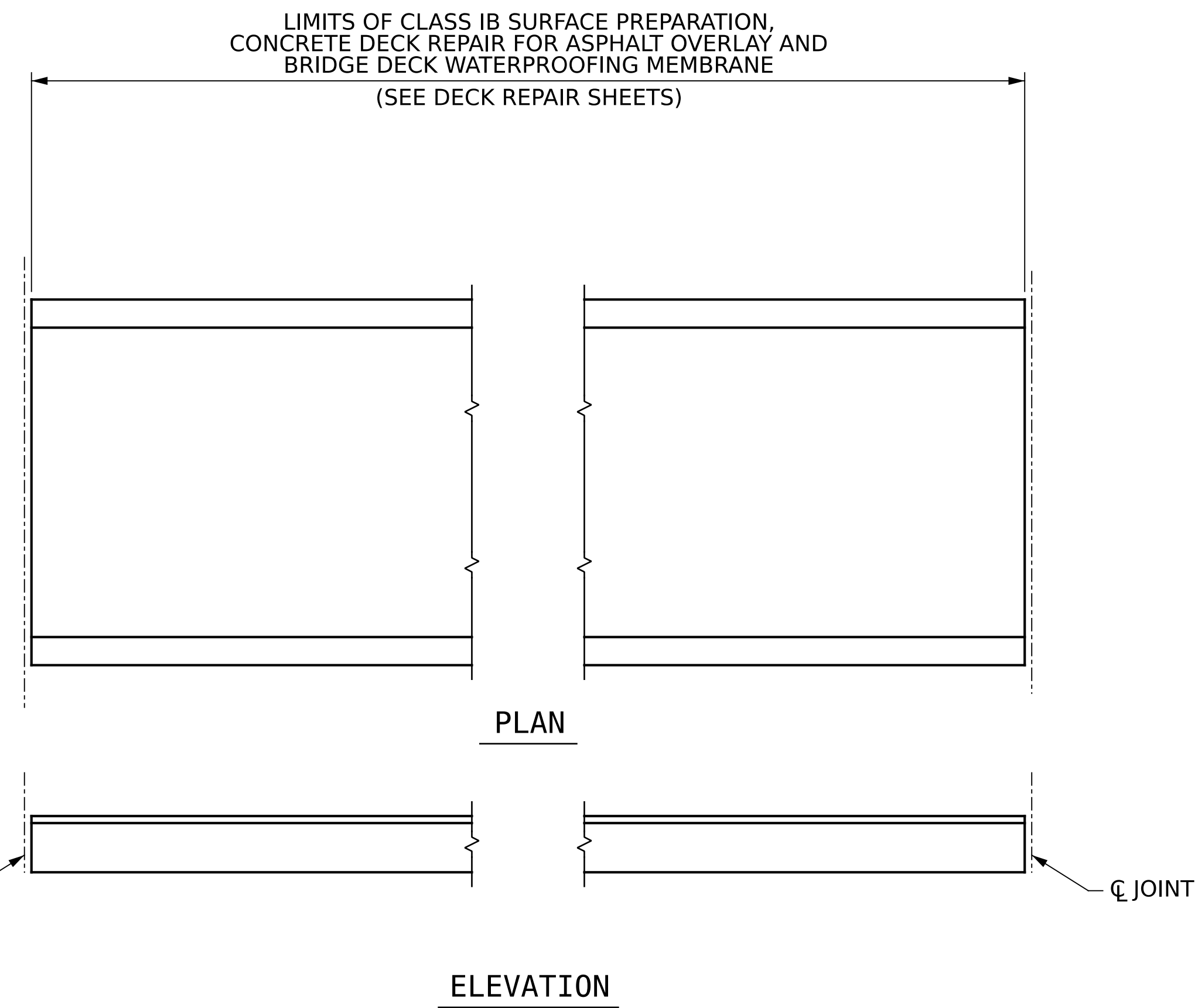

PAY LIMITS FOR OVERLAY BID ITEMS

PROJECT NO. **HI-0018**
COLUMBUS COUNTY
 BRIDGE NO. **230385**

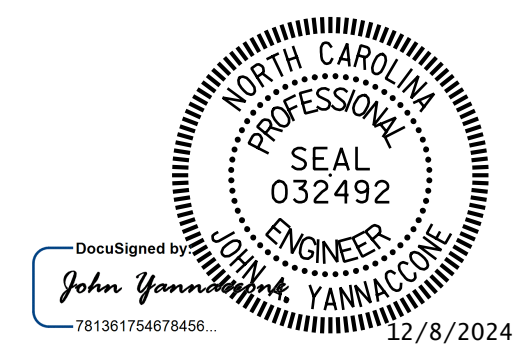

STATE OF NORTH CAROLINA
 DEPARTMENT OF TRANSPORTATION
 RALEIGH

TYPICAL SECTION AND SURFACE PREPARATION DETAILS

DRAWN BY: **R.L.PUTEK** DATE: **08/2024**
 CHECKED BY: **J.A.YANNACCONE** DATE: **08/2024**



One Glenwood Avenue
 Suite 300
 Raleigh, NC 27603
 919-420-7660
 NC Lic. No. F-0270

DOCUMENT NOT CONSIDERED FINAL UNLESS ALL SIGNATURES COMPLETED

REVISIONS				SHEET NO.
NO.	BY:	DATE:	NO.	DATE:
1			3	
2			4	

TOTAL SHEETS: **79**

8/26/24

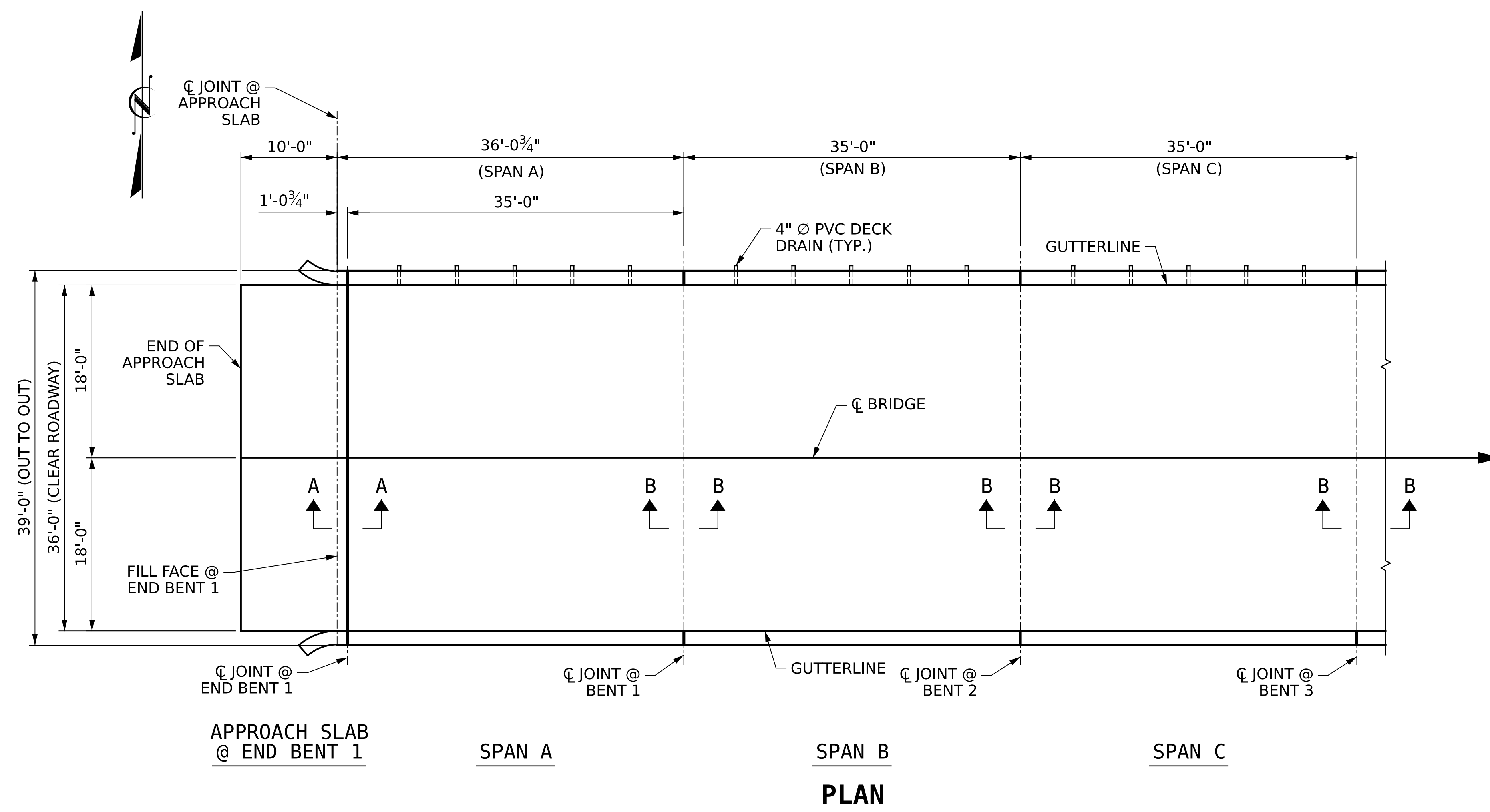

AS-BUILT QUANTITY REPAIR TABLE

DECK SURFACE REPAIR & APPROACH SLAB REPAIR

		ESTIMATE	ACTUAL
CLASS IB SURFACE PREPARATION	APPROACH SLAB @ END BENT 1	40.0 SQ. YDS.	
	SPAN A	144.3 SQ. YDS.	
	SPAN B	140.0 SQ. YDS.	
	SPAN C	140.0 SQ. YDS.	
BRIDGE DECK WATERPROOFING MEMBRANE-SPRAY APPLIED	APPROACH SLAB @ END BENT 1	6.0 SQ. YDS.	
	SPAN A	144.3 SQ. YDS.	
	SPAN B	140.0 SQ. YDS.	
	SPAN C	140.0 SQ. YDS.	

NOTES

- REPAIR LOCATIONS AND ESTIMATED QUANTITIES ARE GIVEN WITH THE BEST INFORMATION AVAILABLE. IF ADDITIONAL REPAIRS NOT SHOWN ON THE DRAWINGS ARE DEEMED NECESSARY BY THE ENGINEER, THE ENGINEER WILL NOTE ON THE DRAWINGS THE APPROXIMATE LOCATIONS AND DESCRIPTION OF THE REPAIRS AND ADJUST THE ACTUAL QUANTITIES ENTERED INTO THE REPAIR QUANTITY TABLE.
- FOR SECTION A-A AND B-B. SEE "ASPHALT PLUG JOINT DETAILS" SHEET.
- FOR CLASS IB SURFACE PREPARATION, SEE BRIDGE DECK ASPHALT OVERLAY SPECIAL PROVISION.
- FOR BRIDGE DECK WATERPROOFING MEMBRANE-SPRAY APPLIED, SEE SPECIAL PROVISIONS.
- FOR ASPHALT OVERLAY, SEE ROADWAY PLANS.

CLASS IB SURFACE PREPARATION

PROJECT NO. **HI-0018**
COLUMBUS COUNTY
 BRIDGE NO. **230385**
 SHEET 1 OF 2

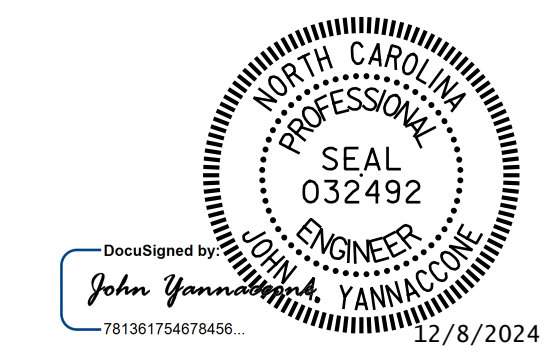

STATE OF NORTH CAROLINA
 DEPARTMENT OF TRANSPORTATION
 RALEIGH

DECK REPAIRS
 SPAN A W/APPROACH SLAB,
 SPAN B & SPAN C

DRAWN BY: **R.L.PUTEK** DATE: **08/2024**
 CHECKED BY: **J.A.YANNACCONI** DATE: **08/2024**



DOCUMENT NOT CONSIDERED FINAL UNLESS ALL SIGNATURES COMPLETED

REVISIONS						SHEET NO.
NO.	BY:	DATE:	NO.	BY:	DATE:	TOTAL SHEETS
1			3			79
2			4			

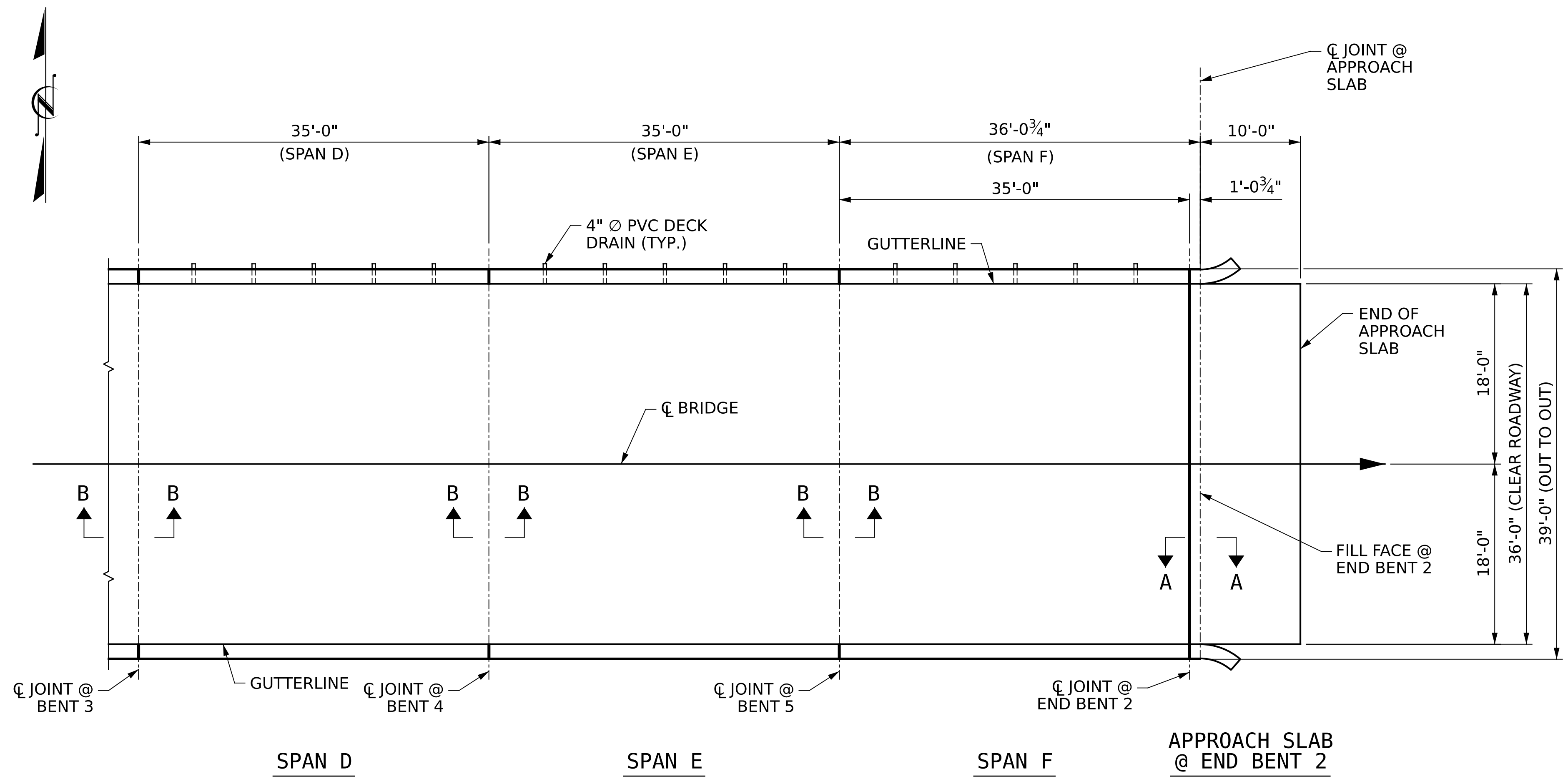

PLAN

AS-BUILT QUANTITY REPAIR TABLE			
DECK SURFACE REPAIR & APPROACH SLAB REPAIR			
		ESTIMATE	ACTUAL
CLASS IB SURFACE PREPARATION	SPAN D	140.0 SQ. YDS.	
	SPAN E	140.0 SQ. YDS.	
	SPAN F	144.3 SQ. YDS.	
	APPROACH SLAB @ END BENT 2	40.0 SQ. YDS.	
BRIDGE DECK WATERPROOFING MEMBRANE-SPRAY APPLIED	SPAN D	140.0 SQ. YDS.	
	SPAN E	140.0 SQ. YDS.	
	SPAN F	144.3 SQ. YDS.	
	APPROACH SLAB @ END BENT 2	6.0 SQ. YDS.	

CLASS IB SURFACE PREPARATION

NOTES

REPAIR LOCATIONS AND ESTIMATED QUANTITIES ARE GIVEN WITH THE BEST INFORMATION AVAILABLE. IF ADDITIONAL REPAIRS NOT SHOWN ON THE DRAWINGS ARE DEEMED NECESSARY BY THE ENGINEER, THE ENGINEER WILL NOTE ON THE DRAWINGS THE APPROXIMATE LOCATIONS AND DESCRIPTION OF THE REPAIRS AND ADJUST THE ACTUAL QUANTITIES ENTERED INTO THE REPAIR QUANTITY TABLE.

FOR SECTION A-A AND B-B. SEE "ASPHALT PLUG JOINT DETAILS" SHEET.

FOR CLASS IB SURFACE PREPARATION, SEE BRIDGE DECK ASPHALT OVERLAY SPECIAL PROVISION.

FOR BRIDGE DECK WATERPROOFING MEMBRANE-SPRAY APPLIED, SEE SPECIAL PROVISIONS.

FOR ASPHALT OVERLAY, SEE ROADWAY PLANS.

PROJECT NO. **HI-0018**
COLUMBUS COUNTY
 BRIDGE NO. **230385**
 SHEET 2 OF 2

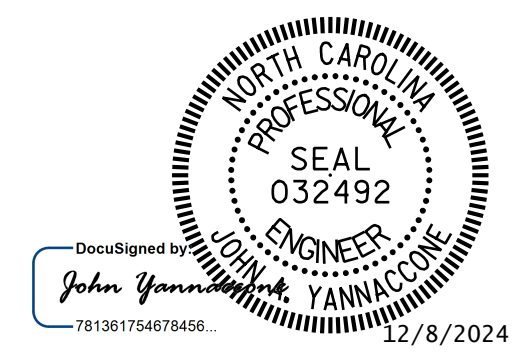

STATE OF NORTH CAROLINA
 DEPARTMENT OF TRANSPORTATION
 RALEIGH

DECK REPAIRS
 SPAN D, SPAN E &
 SPAN F W/APPROACH SLAB

DRAWN BY: **R.L.PUTEK** DATE: **08/2024**
 CHECKED BY: **J.A.YANNACCONE** DATE: **08/2024**



REVISIONS						SHEET NO.
NO.	BY:	DATE:	NO.	BY:	DATE:	TOTAL SHEETS
1			3			79
2			4			

DOCUMENT NOT CONSIDERED FINAL UNLESS ALL SIGNATURES COMPLETED

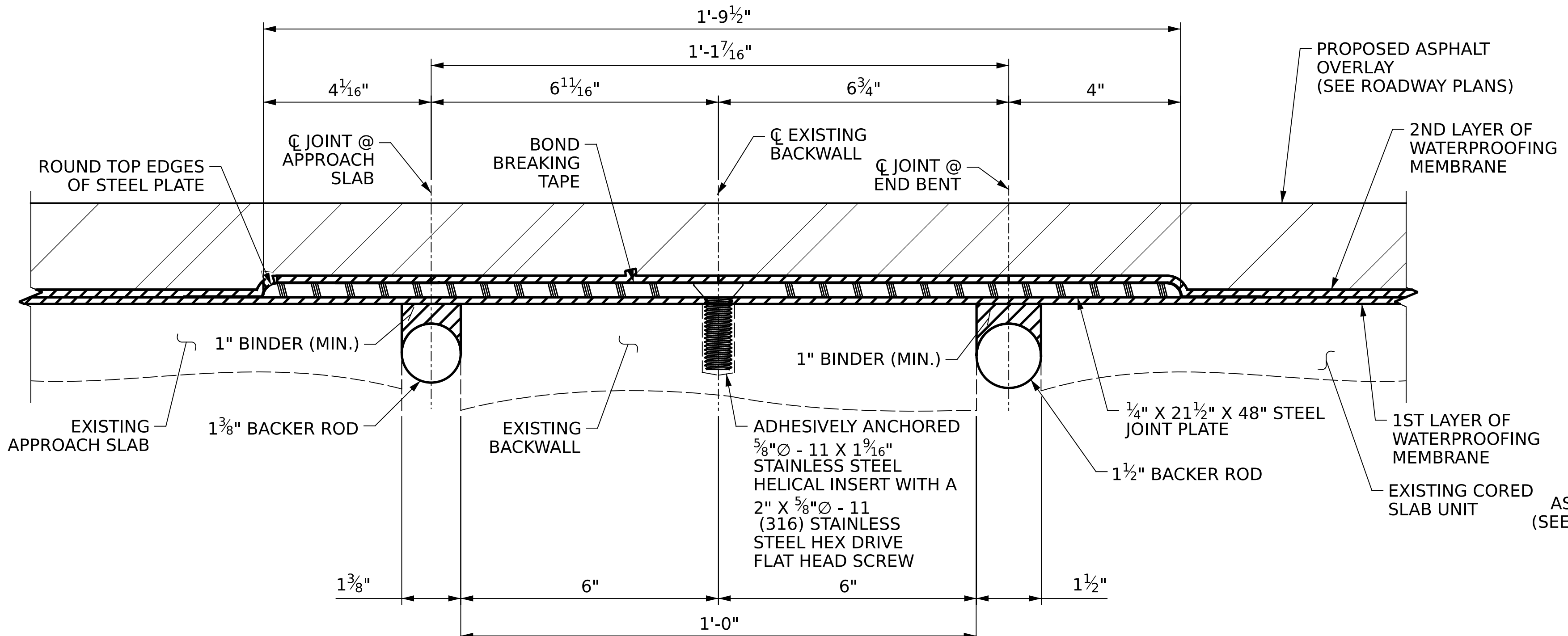

DETAIL "G"
(PROPOSED)

**AS-BUILT
SUMMARY OF QUANTITIES**

LOCATION	ASPHALT PLUG JOINT FOR PRESERVATION (LIN. FT.)
APPROACH SLAB @ END BENT 1	38.5
END BENT 1	38.5
BENT 1	38.5
BENT 2	38.5
BENT 3	38.5
BENT 4	38.5
BENT 5	38.5
END BENT 2	38.5
APPROACH SLAB @ END BENT 2	38.5

NOTES:

THE CONTRACTOR SHALL FIELD VERIFY THE EXISTING JOINT OPENING PRIOR TO ORDERING JOINT MATERIALS.

THE MANUFACTURER IS TO PROVIDE THE NOMINAL UNCOMPRESSED SEAL WIDTH OF THE BACKER ROD FOR THE EXISTING JOINT SIZE AND ACCOMMODATE THE MINIMUM EXPANSION SHOWN ON THE PLANS.

ONLY ASPHALTIC PLUG JOINTS THAT ARE APPROVED ON NCDOT'S APPROVED PRODUCTS LIST SHALL BE USED. CONTACT SMU PRESERVATION AND REPAIR AT LEAST 3 DAYS PRIOR TO JOINT INSTALLATION.

ASPHALTIC PLUG JOINTS SHALL BE INSTALLED AS PER THE MANUFACTURER'S RECOMMENDATIONS.

A MANUFACTURER'S CERTIFIED TRAINED REPRESENTATIVE SHALL BE PRESENT DURING THE INSTALLATION OF THE FIRST JOINT OF THE PROJECT, OR UNTIL THE ENGINEER IS SATISFIED WITH THE INSTALL PROCESS.

THE CONTRACTOR SHALL TAKE CARE DURING JOINT REHAB OPERATIONS NOT TO ALLOW ANY MATERIAL FALL BELOW THE BRIDGE. ANY MATERIAL THAT FALLS BELOW THE BRIDGE SHALL BE CONTAINED, REMOVED AND DISPOSED OF BY THE CONTRACTOR AT NO EXTRA COST TO THE DEPARTMENT. IF THE ENGINEER DETERMINES THAT THE PROTECTIVE DEVICES ARE NOT ADEQUATE OR NOT BEING EMPLOYED, THE WORK SHALL BE SUSPENDED UNTIL ADEQUATE PROTECTION IS PROVIDED.

THE STEEL BRIDGE PLATE SHALL BE A MINIMUM OF 36 KSI STEEL. THE STEEL BRIDGE PLATE THICKNESS SHALL BE A MINIMUM OF 1/4".

FOR ASPHALT PLUG JOINTS FOR PRESERVATION, SEE SPECIAL PROVISIONS

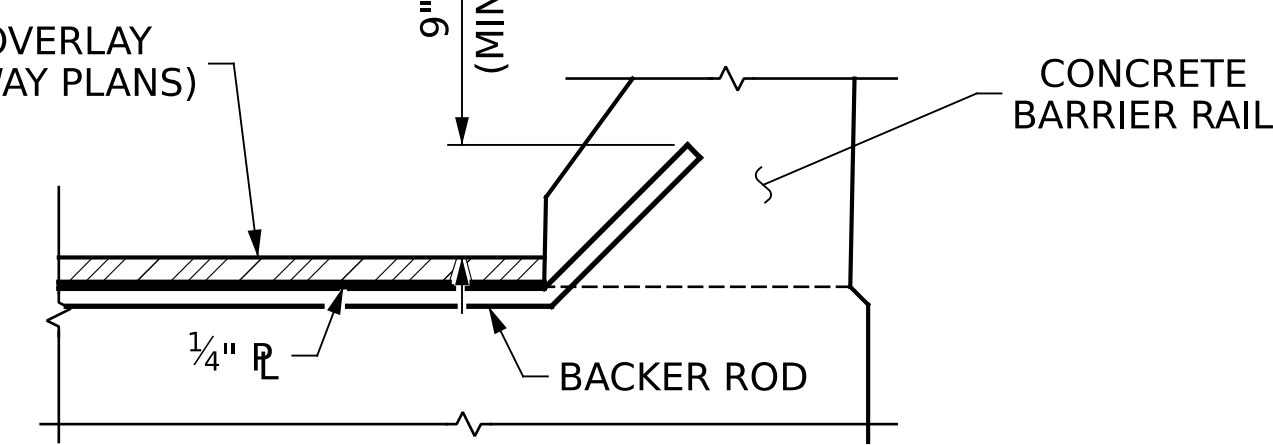

SECTION AT GUTTERLINE
(PROPOSED PLUG JOINT)

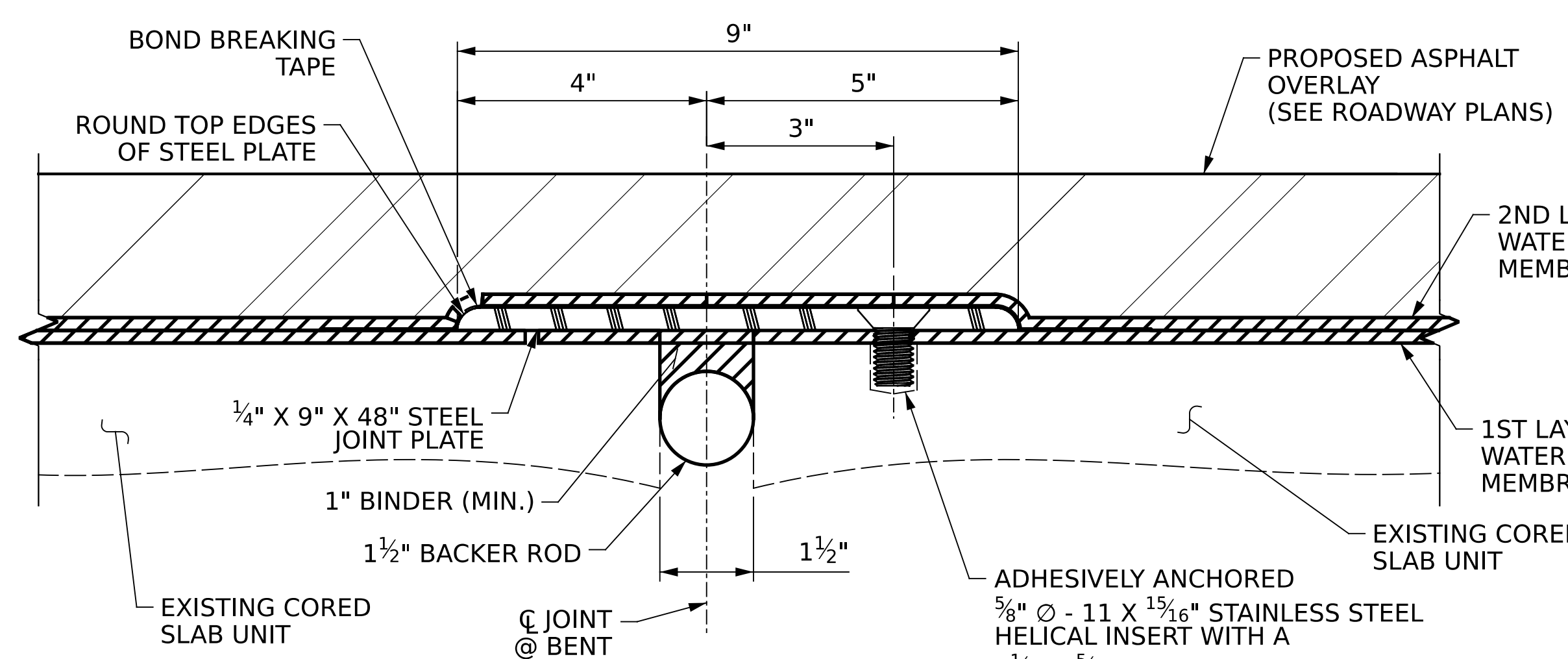

DETAIL "H"
(PROPOSED)

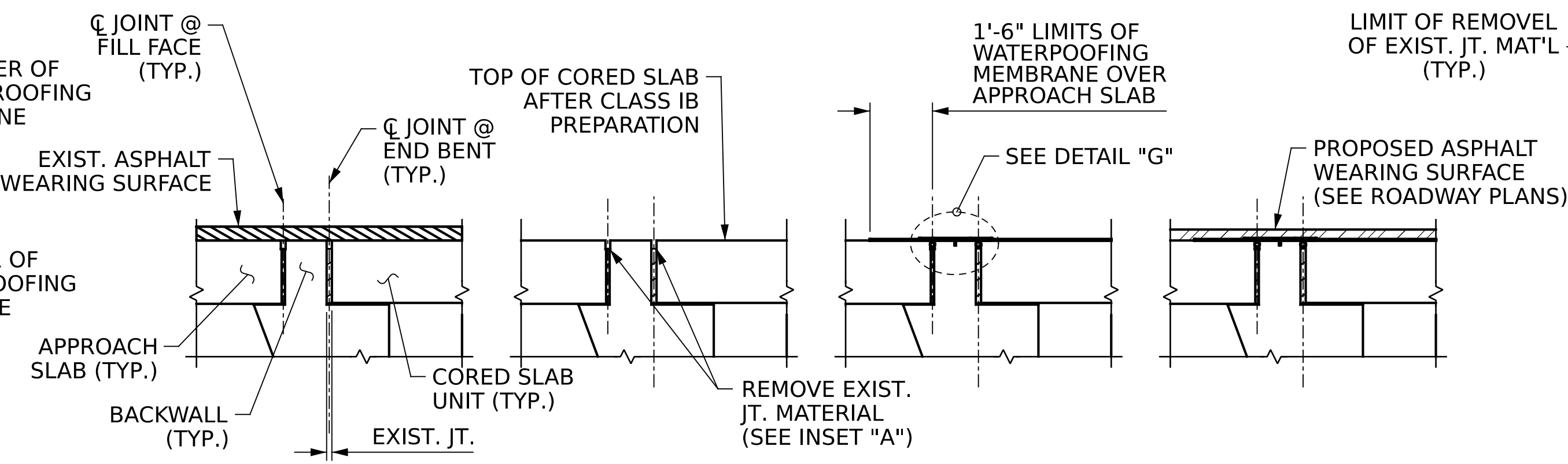

SECTION A-A
(AT END BENTS)

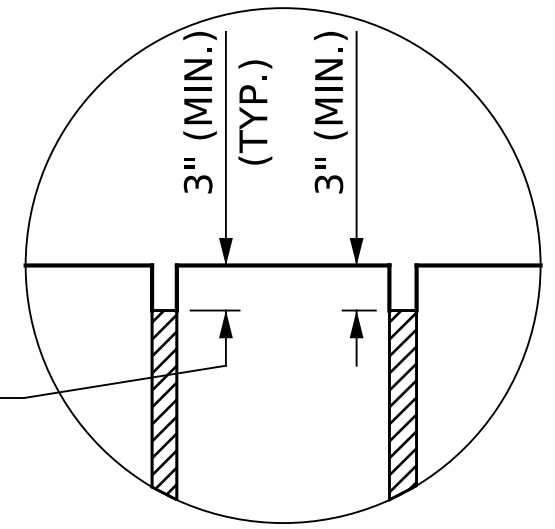

INSET "A"

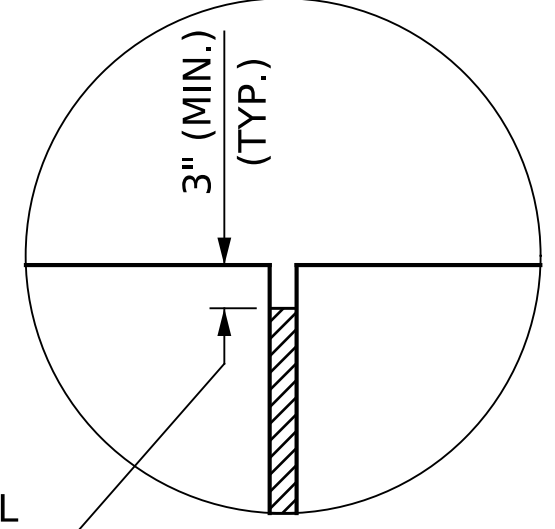

INSET "B"

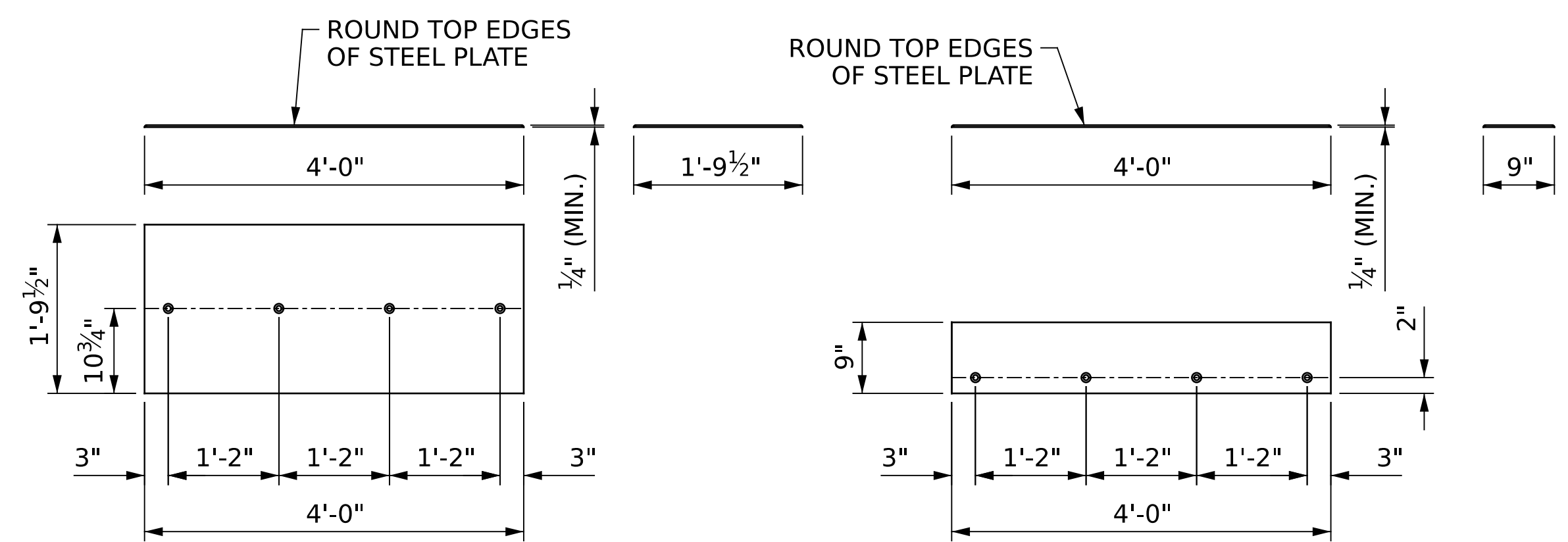

STEEL JOINT PLATE

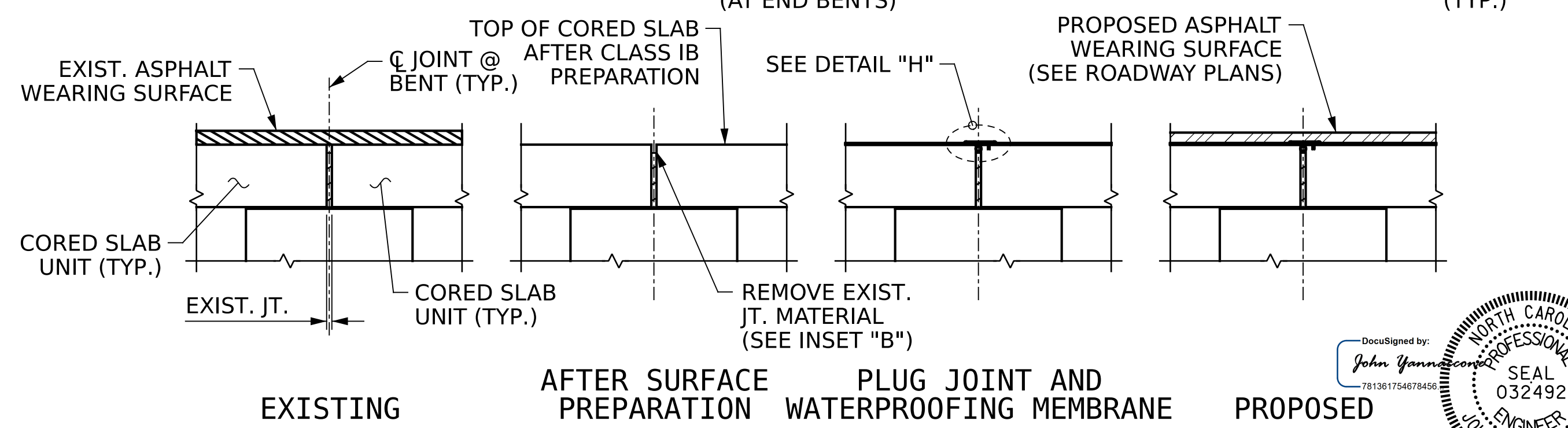

SECTION B-B
(AT BENTS)

PROJECT NO. **HI-0018**
COLUMBUS COUNTY
BRIDGE NO. **230385**

STATE OF NORTH CAROLINA
DEPARTMENT OF TRANSPORTATION
RALEIGH

**ASPHALT PLUG JOINT
DETAILS**

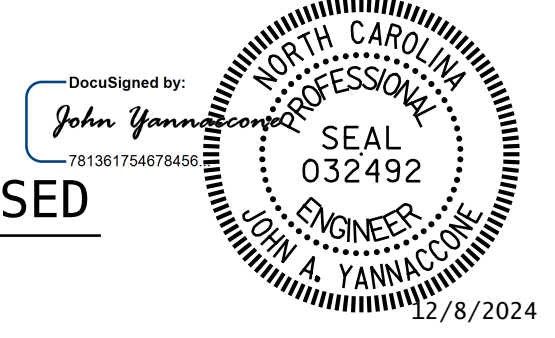

DRAWN BY: R.L. PUTEK DATE: 08/2024
CHECKED BY: J.A. YANNACCONI DATE: 08/2024



One Glenwood Avenue
Suite 300
Raleigh, NC 27603
919-420-7660
NC Lic. No. F-0270

DOCUMENT NOT CONSIDERED
FINAL UNLESS ALL
SIGNATURES COMPLETED

REVISIONS				SHEET NO.
NO.	BY:	DATE:	NO.	DATE:
1			3	
2			4	

TOTAL SHEETS: 79

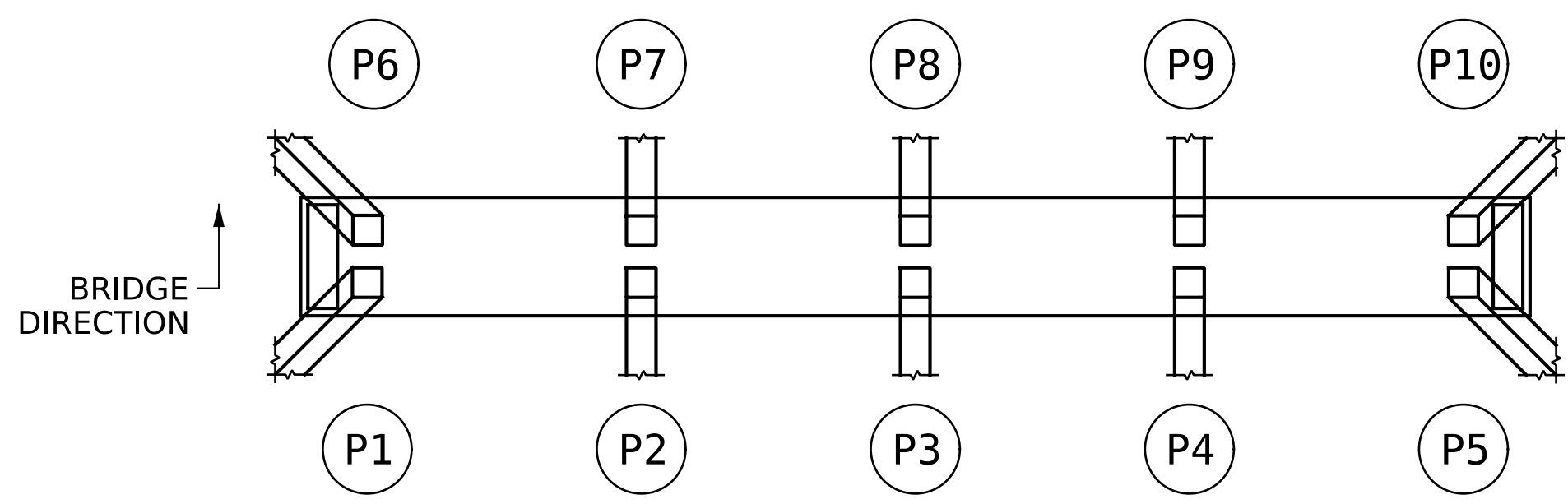

PLAN

(BENT 1 SHOWN, BENTS 2 THRU 5 SIMILAR)

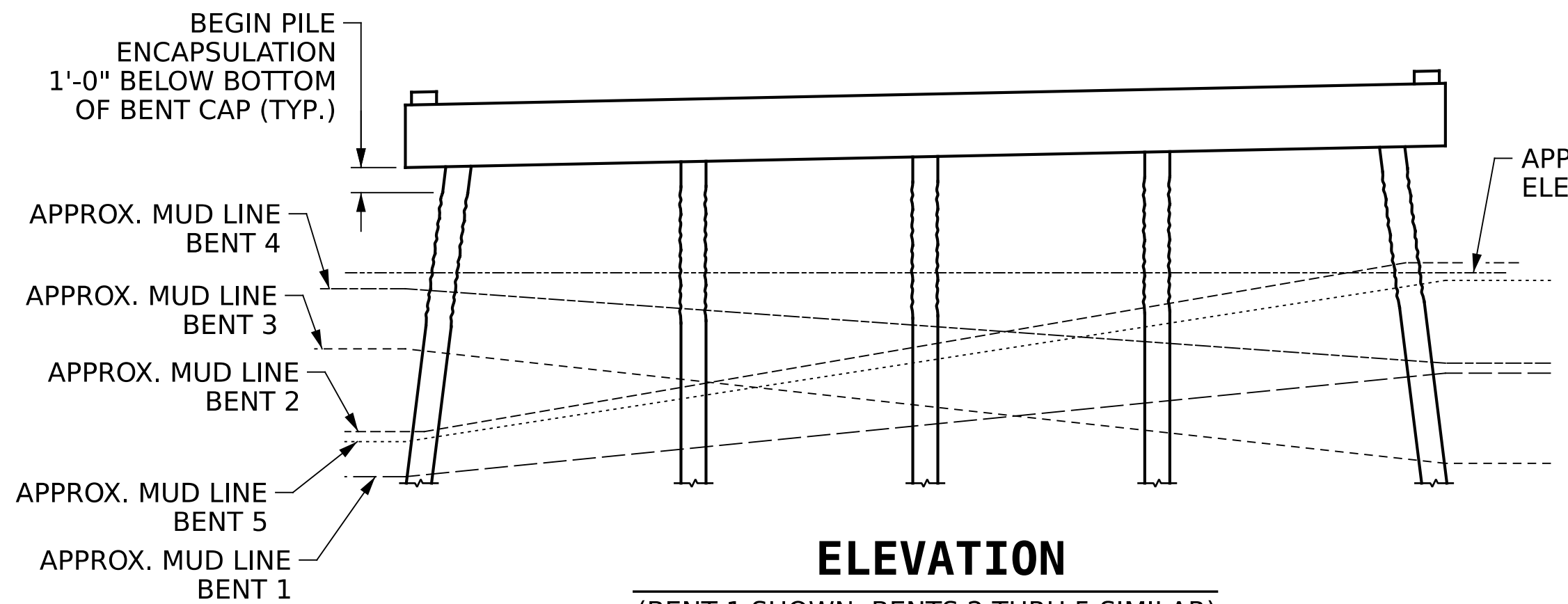

ELEVATION

(BENT 1 SHOWN, BENTS 2 THRU 5 SIMILAR)

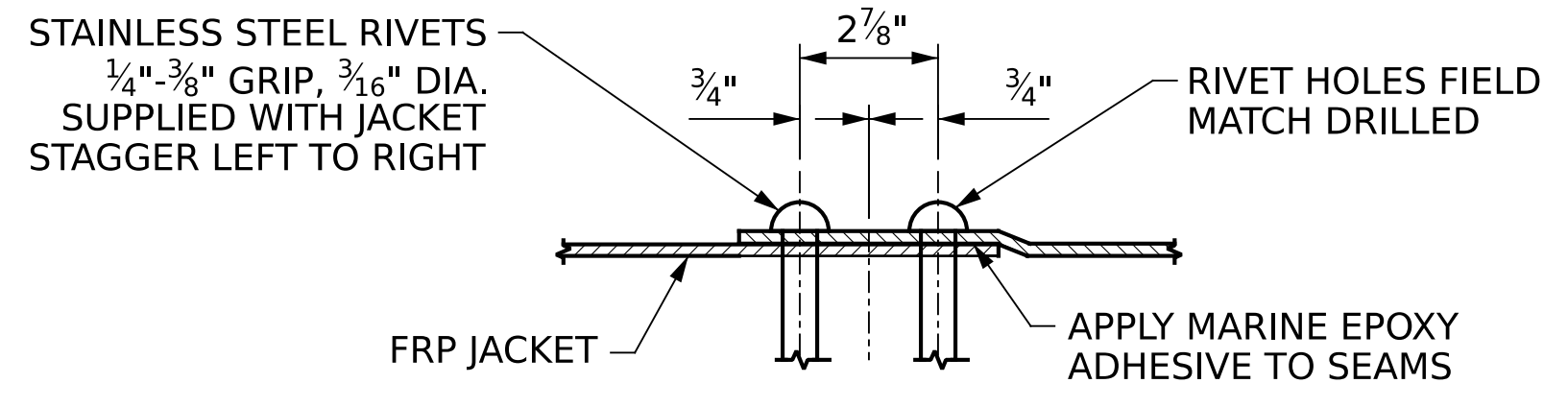

DETAIL A

(SEAM DETAIL)

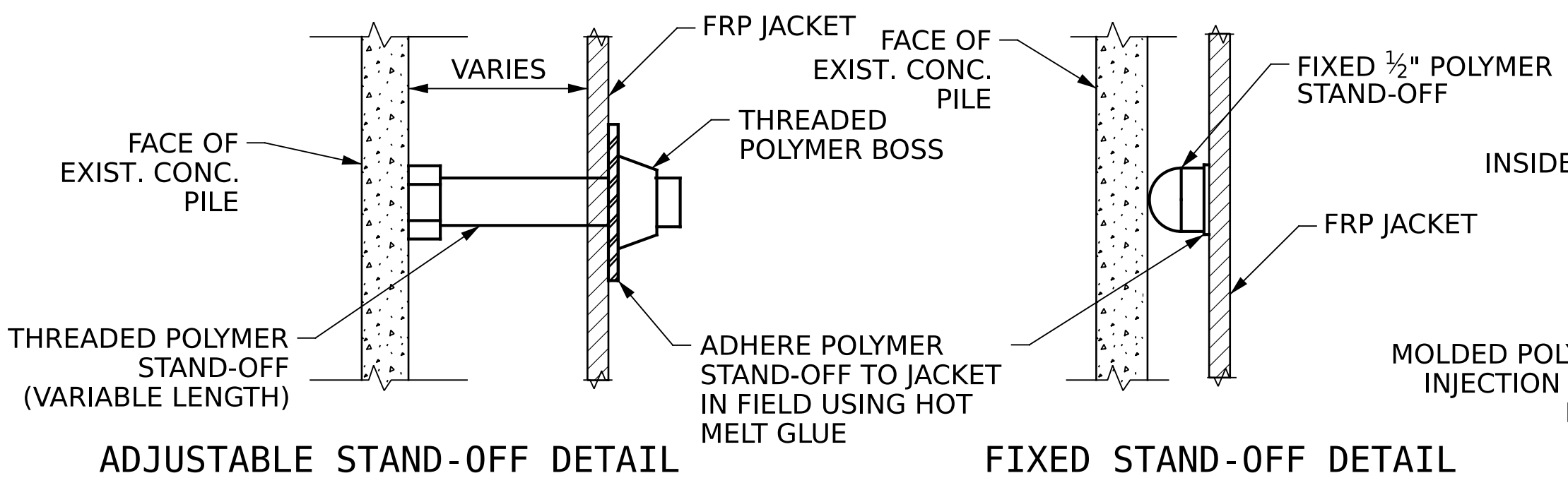

DETAIL B

ADJUSTABLE STAND-OFF DETAIL

FIXED STAND-OFF DETAIL

DETAIL C

(TOP OF JACKET)

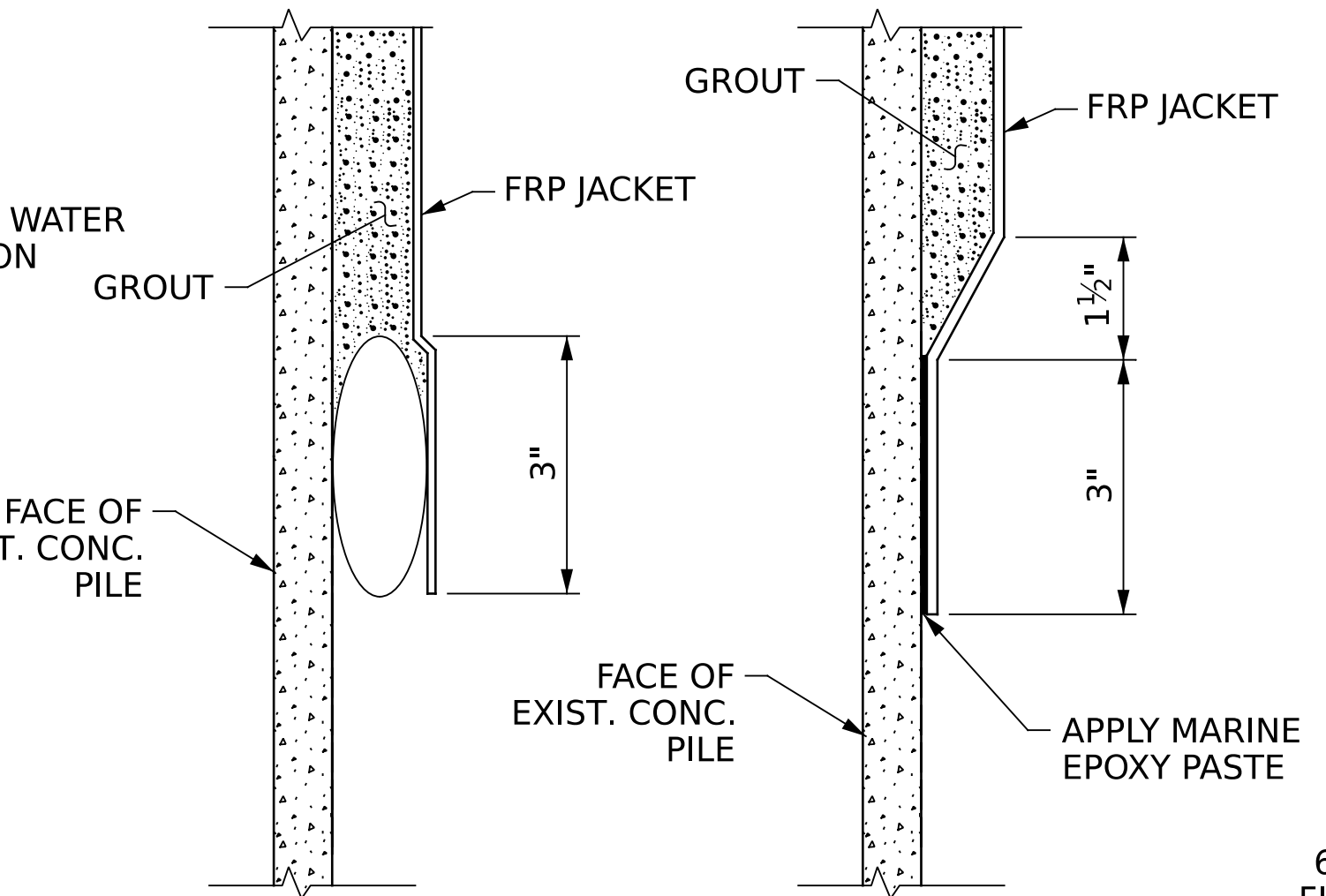

BOTTOM SEAL DETAIL

ALTERNATE BOTTOM SEAL DETAIL

DETAIL D

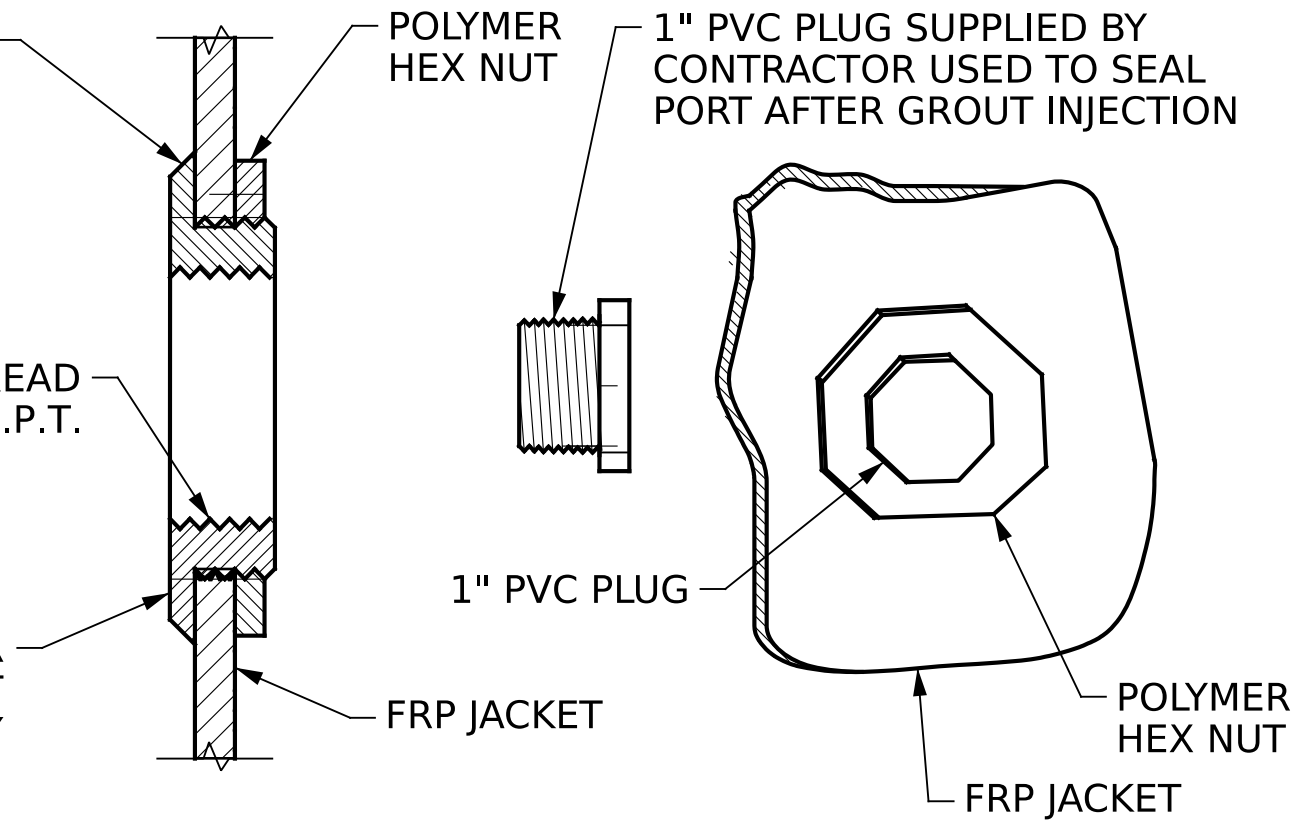

SECTION THRU PORT

ISOMETRIC VIEW

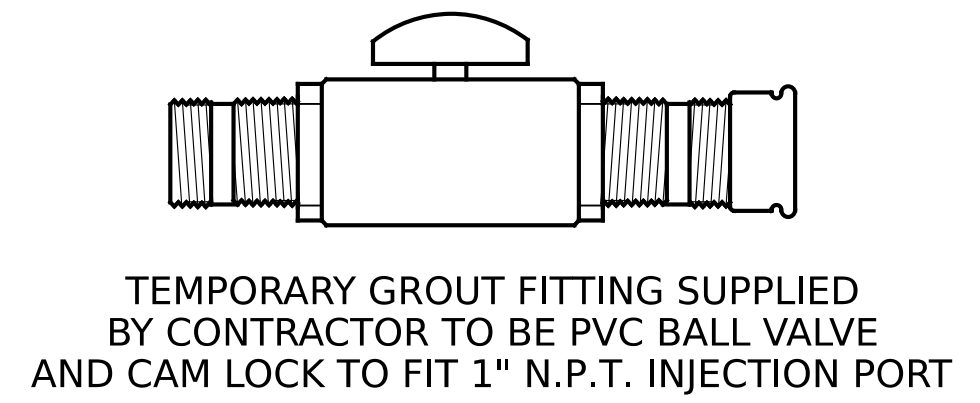

DETAIL E

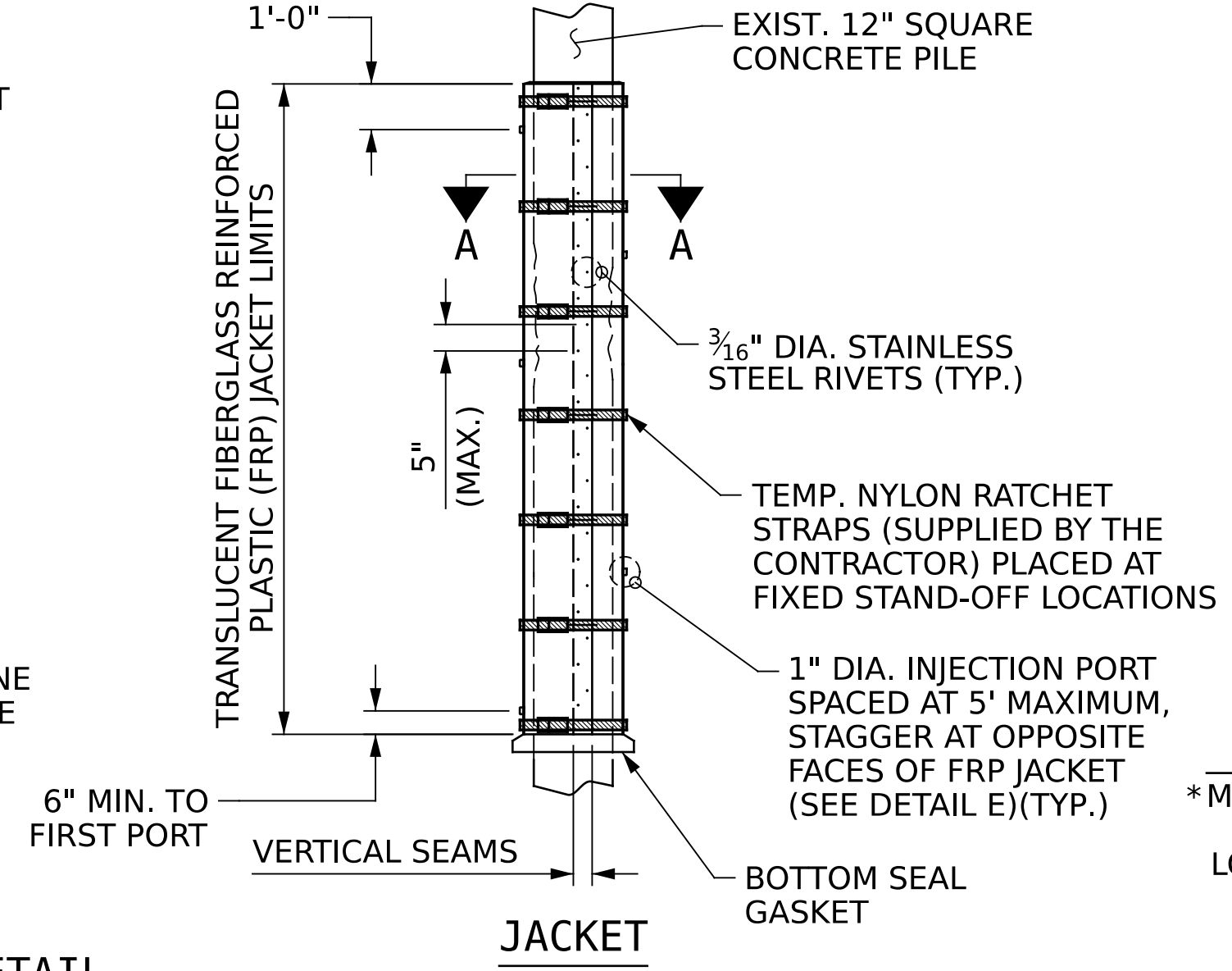

JACKET

CONCRETE PILE ENCAPSULATION

NOTE:

THE FLOATING TURBIDITY CURTAIN QUANTITY SHOWN ON THE TOTAL BILL OF MATERIAL IS BASED ON A 4.0' WATER DEPTH AND THE LENGTH NECESSARY TO FULLY ENCOMPASS ONE INTERIOR BENT.

FOR FLOATING TURBIDITY CURTAIN, SEE SPECIAL PROVISIONS.

CONTRACTOR SHALL MAKE ALL REASONABLE EFFORTS TO LIMIT CONTAMINATION OF THE WATER DURING EXCAVATION FOR THE PILE ENCAPSULATION, PUMPING OF EPOXY GROUT, AND ALL OTHER WORK TO INSTALL THE PILE ENCAPSULATION.

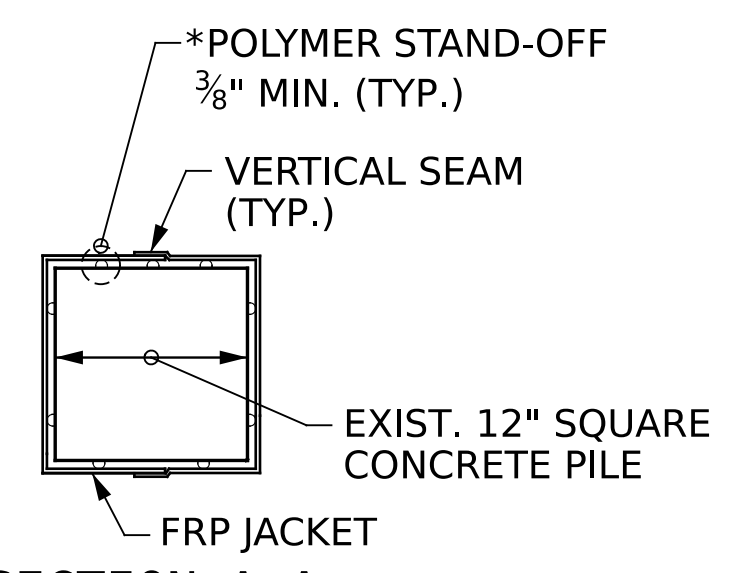

SECTION A-A

*MAXIMUM SPACING BETWEEN FIXED STAND-OFFS SHALL BE 18" THE LONGITUDINAL DIRECTION AND 12" THE TRAVERSE DIRECTION (SEE DETAIL B)

AS-BUILT SUMMARY OF QUANTITIES
CONCRETE PILE ENCAPSULATION LOCATION TABLE

LOCATION	FIBERGLASS REINFORCED PLASTIC (FRP) JACKET LENGTHS (LIN. FT.)										ESTIMATE	ACTUAL
	P1	P2	P3	P4	P5	P6	P7	P8	P9	P10		
BENT 1	10.1	9.7	9.3	8.9	8.4	10.1	9.7	9.3	8.9	8.4	92.8	
BENT 2	8.4	7.3	6.1	5.0	3.8	8.4	7.3	6.1	5.0	3.8	61.2	
BENT 3	8.0	8.8	9.5	10.3	11.1	8.0	8.8	9.5	10.3	11.1	95.4	
BENT 4	5.8	6.2	6.7	7.2	7.6	5.8	6.2	6.7	7.2	7.6	67.0	
BENT 5	10.9	9.3	7.7	6.1	4.5	10.9	9.3	7.7	6.1	4.5	77.0	
TOTAL											393.4	

PILE ENCAPSULATION EXTENDS FROM 1'-0" BELOW BOTTOM OF BENT CAP TO 1'-0" BELOW MUDLINE.

QUANTITIES ARE BASED ON BEST AVAILABLE INFORMATION. CONTRACTOR SHALL VERIFY MUD LINE ELEVATION PRIOR TO INSTALLATION OF JACKETS.

REPAIR SEQUENCE

- INSTALL FLOATING TURBIDITY CURTAIN TO ENCOMPASS ENTIRE INTERIOR BENT. ALLOW ENOUGH SPACE FOR PILE ENCAPSULATION WORK.
- AFTER SURFACE PREPARATION, PLACE JACKET IN PROPER LOCATION AROUND PILE AND SEAL LONGITUDINAL SEAMS (SEE DETAIL A). INSTALL TEMPORARY BRACING.
- CONFIRM SPACING BETWEEN JACKET AND PILE. INSTALL BOTTOM SEAL (SEE DETAIL D). ALLOW BOTTOM SEAL TO CURE APPROX. 4 HOURS.
- ATTACH GROUT HOSE TO LOWEST INJECTION PORT AND PUMP EPOXY GROUT FOR 30-SEC. CHECK FOR LEAKS ALONG SEAM AND BOTTOM SEAL. (OPTIONALLY ALLOW THIS GROUT TO CURE AND PROCEED WITH GROUT INJECTION FROM 2ND PORT.)
- PUMP UPPER PORTS AND PUMP GROUT INTO LOWER PORT UNTIL GROUT REACHES TOP OF JACKET. ONLY USE UPPER PORTS IF INJECTION BECOME DIFFICULT.
- REPEAT STEPS 2 THRU 5 FOR EACH PILE WITHIN ONE BENT.
- WHEN PILE ENCAPSULATION WORK AT THE BENT IS COMPLETE, REMOVE FLOATING TURBIDITY CURTAIN AND REINSTALL THE CURTAIN FOR THE PILE ENCAPSULATION WORK AT THE NEXT INTERIOR BENT.

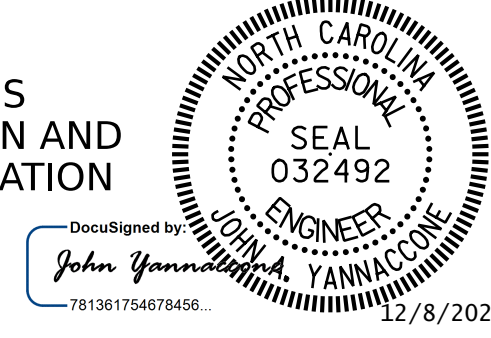

PROJECT NO. **HI-0018**
COLUMBUS COUNTY
BRIDGE NO. **230385**

STATE OF NORTH CAROLINA
DEPARTMENT OF TRANSPORTATION
RALEIGH
SUBSTRUCTURE REPAIR
CONCRETE PILE ENCAPSULATION

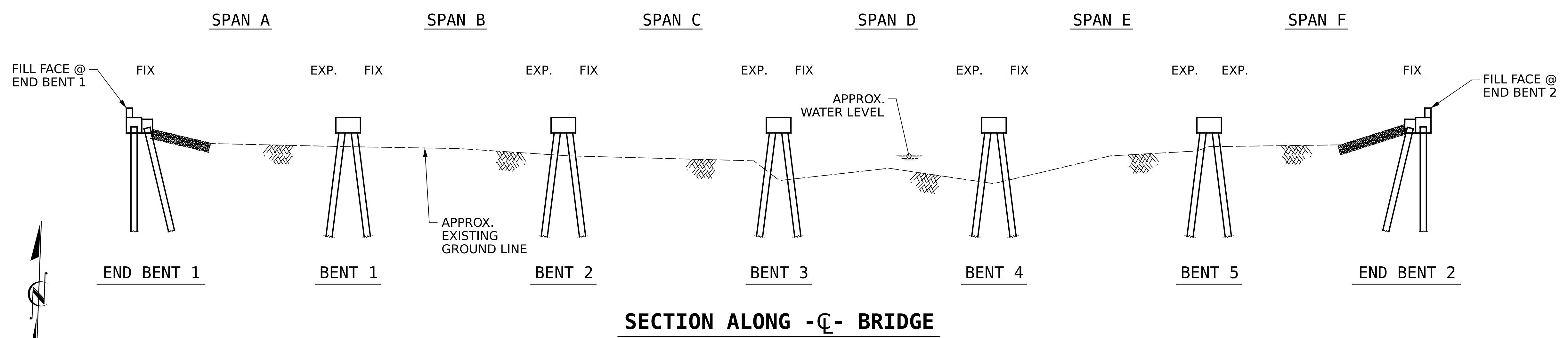

NOTES:
 GENERAL DRAWING INFORMATION IS TAKEN FROM THE ORIGINAL PLANS AND THE ROUTINE INSPECTION REPORT DATED 07/15/2024.

BRIDGE ORIENTATION CONFORMS TO THE EXISTING BRIDGE PLANS AND ROUTINE INSPECTION REPORT.

- SCOPE OF WORK:**
- REMOVE ASPHALT WEARING SURFACE BY SCARIFICATION.
 - INSTALL WATERPROOFING MEMBRANE.
 - OVERLAY PREPARED TOP OF CORED SLABS WITH ASPHALT OVERLAY.
 - REMOVE EXISTING JOINT AND INSTALL ASPHALT PLUG JOINTS.
 - ENCAPSULATE CONCRETE PILES WITH FRP JACKETS.

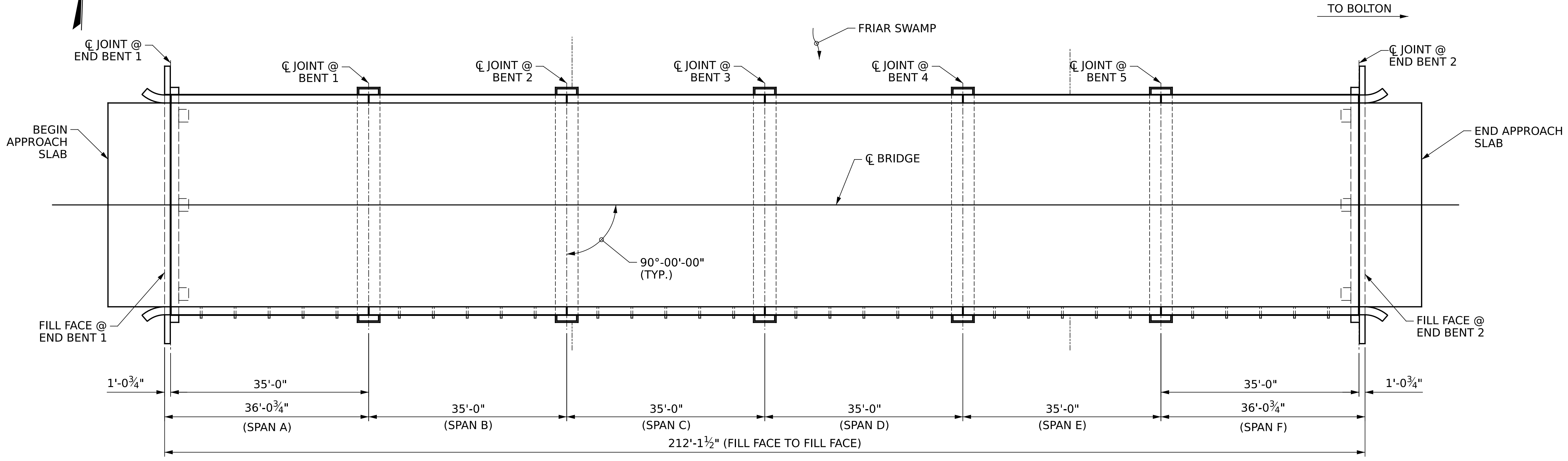

PLAN
 (FOOTINGS AND PILES NOT SHOWN FOR CLARITY)

PROJECT NO. **HI-0018**
COLUMBUS COUNTY
 BRIDGE NO. **230386**
 SHEET 1 OF 2

STATE OF NORTH CAROLINA
 DEPARTMENT OF TRANSPORTATION
 RALEIGH
GENERAL DRAWING
 FOR BRIDGE ON
 US 74 - US 76 BYP EBL
 OVER FRIAR SWAMP

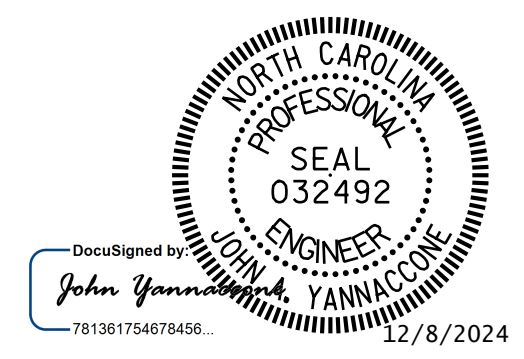

I HEREBY CERTIFY THAT THIS STRUCTURE WAS REHABILITATED ACCORDING TO THESE PLANS OR AS NOTED HEREIN.

RESIDENT ENGINEER _____ DATE _____



DOCUMENT NOT CONSIDERED FINAL UNLESS ALL SIGNATURES COMPLETED

REVISIONS				SHEET NO.	
NO.	BY:	DATE:	NO.	BY:	DATE:
1			3		
2			4		

TOTAL SHEETS: 79

DRAWN BY: R.L.PUTEK DATE: 08/2024
 CHECKED BY: J.A.YANNACONE DATE: 08/2024