

## ONSITE CONCRETE WASHOUT STRUCTURE WITH LINER

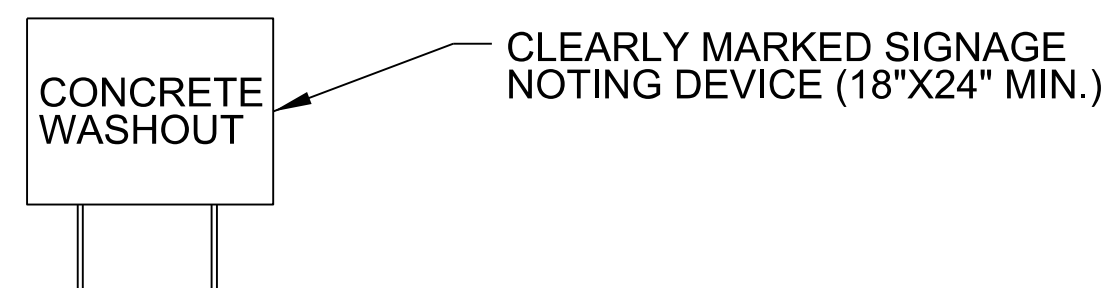
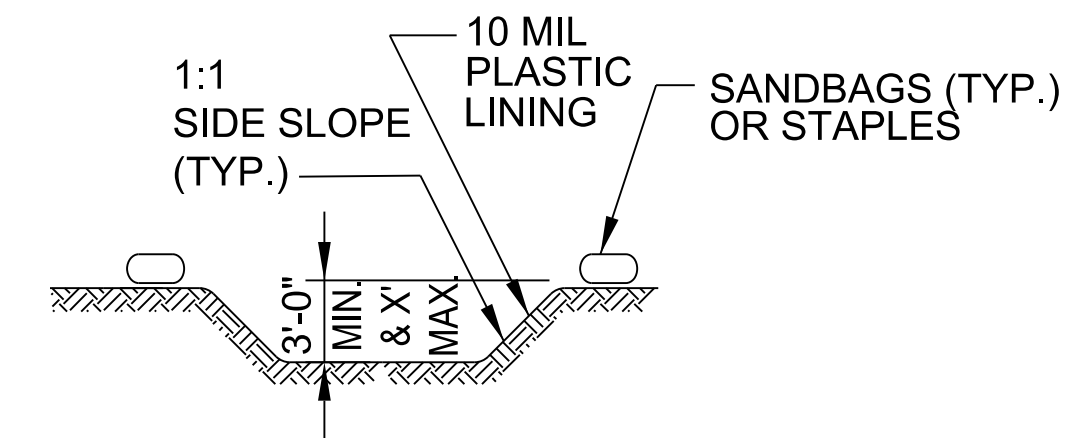
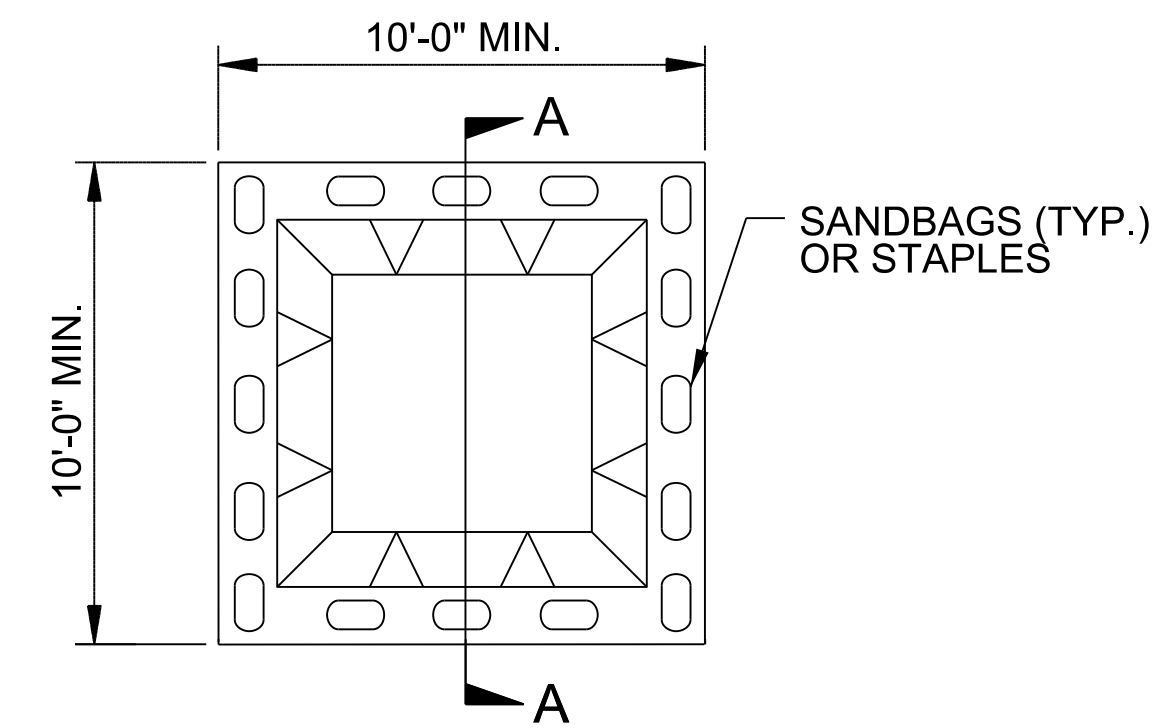

### SECTION A-A

**NOTES:**

1. ACTUAL LOCATION DETERMINED IN FIELD
2. THE CONCRETE WASHOUT STRUCTURES SHALL BE MAINTAINED WHEN THE LIQUID AND/OR SOLID REACHES 75% OF THE STRUCTURES CAPACITY.
3. CONCRETE WASHOUT STRUCTURE NEEDS TO BE CLEARLY MARKED WITH SIGNAGE NOTING DEVICE.

PLAN

## BELOW GRADE WASHOUT STRUCTURE

NOT TO SCALE

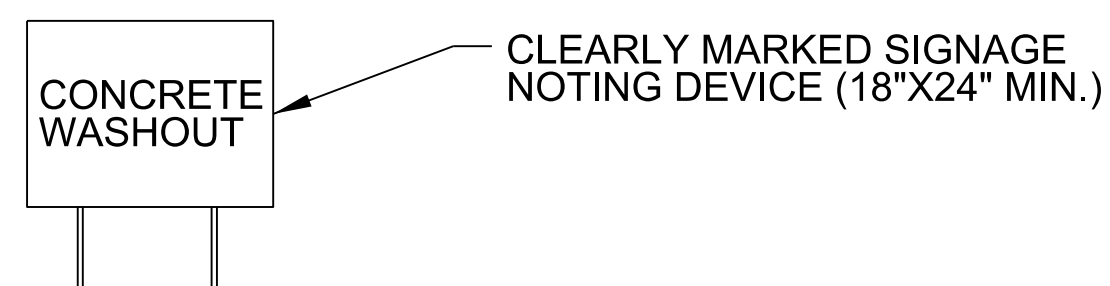
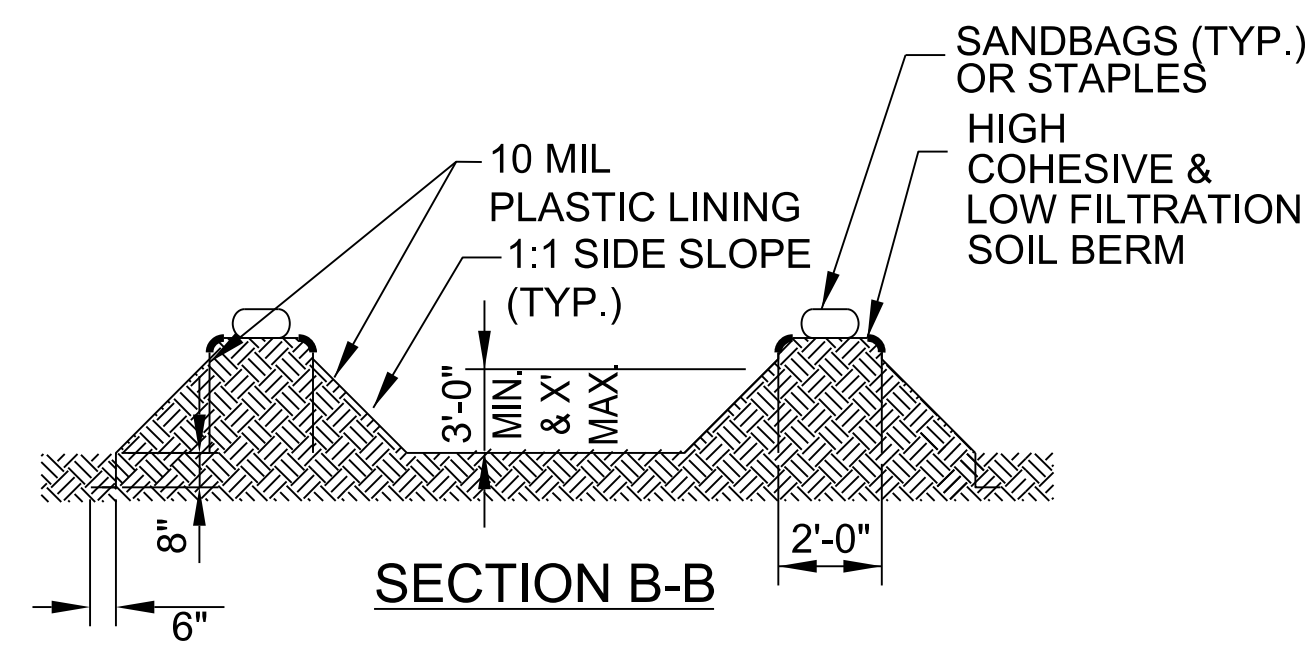
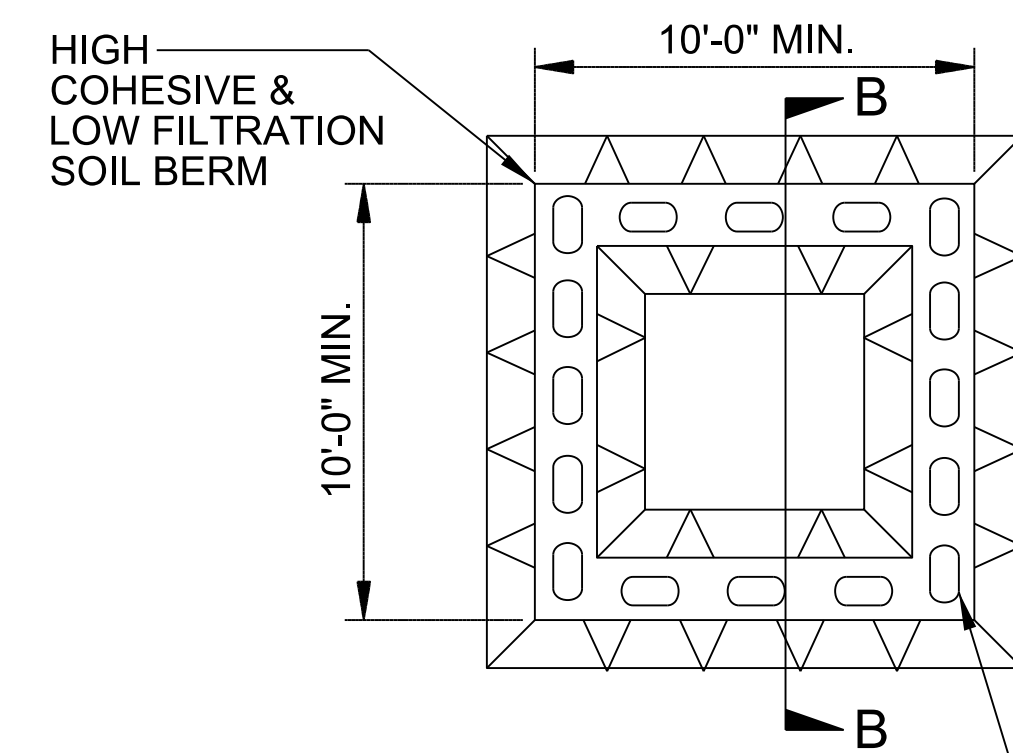

**NOTES:**

1. ACTUAL LOCATION DETERMINED IN FIELD
2. THE CONCRETE WASHOUT STRUCTURES SHALL BE MAINTAINED WHEN THE LIQUID AND/OR SOLID REACHES 75% OF THE STRUCTURES CAPACITY TO PROVIDE ADEQUATE HOLDING CAPACITY WITH A MINIMUM 12 INCHES OF FREEBOARD.
3. CONCRETE WASHOUT STRUCTURE NEEDS TO BE CLEARLY MARKED WITH SIGNAGE NOTING DEVICE.

PLAN

## ABOVE GRADE WASHOUT STRUCTURE

NOT TO SCALE