

T.I.P. PROJECT: R-5709C

CONTRACT: C204992

**STATE OF NORTH CAROLINA
DEPARTMENT OF TRANSPORTATION**

**PAVEMENT MARKING PLAN
HOKE COUNTY**

**LOCATION: NC 211 FROM 0.40 MILES NORTH OF SR 1225 (ASHEMONT ROAD) TO EAST
OF SR 1244 (WEST PALMER STREET)/SR 1311 (MOCKINGBIRD HILL ROAD)
IN RAEFORD.**

<small>PROJECT REFERENCE NO.</small> R-5709C	<small>SHEET NO.</small> PMP-1
<small>APPROVED:</small> <small>08183F2B5741E</small> 10/11/2024	
<small>DATE:</small>	
<small>SEAL</small> 	
<small>DOCUMENT NOT CONSIDERED FINAL UNLESS ALL SIGNATURES COMPLETED</small>	

INDEX

<u>SHEET NO.</u>	<u>DESCRIPTION</u>
PMP-1	PAVEMENT MARKING PLAN TITLE SHEET
PMP-1A	DETAILS TO BE USED IN LIEU OF 2024 STANDARD DETAILS
PMP-2 THRU PMP-39	PAVEMENT MARKING DETAIL

ROADWAY STANDARD DRAWINGS

THE FOLLOWING ROADWAY STANDARDS AS APPEAR IN "ROADWAY STANDARD DRAWINGS" - N.C. DEPARTMENT OF TRANSPORTATION - RALEIGH, N.C., DATED JANUARY 2024 ARE APPLICABLE TO THIS PROJECT AND BY REFERENCE HEREBY ARE CONSIDERED A PART OF THESE PLANS:

<u>STD. NO.</u>	<u>TITLE</u>
1205.01	PAVEMENT MARKINGS - LINE TYPES AND OFFSETS
1205.02	PAVEMENT MARKINGS - TWO-LANE AND MULTI-LANE ROADWAYS
1205.04	PAVEMENT MARKINGS - INTERSECTIONS
1205.05	PAVEMENT MARKINGS - TURN LANES
1205.06	PAVEMENT MARKINGS - LANE DROPS
1205.07	PAVEMENT MARKINGS - PEDESTRIAN CROSSWALKS
1205.08	PAVEMENT MARKINGS - SYMBOLS AND WORD MESSAGES
1205.09	PAVEMENT MARKINGS - PAINTED ISLANDS
1205.10	PAVEMENT MARKINGS - SCHOOL AREAS
1205.11	PAVEMENT MARKINGS - RAILROAD CROSSINGS
1205.14	PAVEMENT MARKINGS - ROUNDABOUTS
1205.15	PAVEMENT MARKINGS - REDUCED CONFLICT INTERSECTIONS
1250.01	RAISED PAVEMENT MARKERS - INSTALLATION SPACING (SHEETS 1 & 3 OF 3)
1251.01	RAISED PAVEMENT MARKERS - PERMANENT AND TEMPORARY

GENERAL NOTES

THE FOLLOWING GENERAL NOTES APPLY AT ALL TIMES FOR THE DURATION OF THE CONSTRUCTION PROJECT, EXCEPT WHEN OTHERWISE NOTED IN THE PLAN, OR DIRECTED BY THE ENGINEER.

- A. INSTALL PAVEMENT MARKINGS AND PAVEMENT MARKERS ON THE FINAL SURFACE AS FOLLOWS:

ROAD NAME	MARKING	MARKER
-L- NC-211, -Y13-, -Y26-	THERMOPLASTIC	PERMANENT RAISED
ALL OTHER -Y- LINES	THERMOPLASTIC	NONE
- B. TIE PROPOSED PAVEMENT MARKING LINES TO EXISTING PAVEMENT MARKING LINES.
- C. REMOVE/REPLACE ANY CONFLICTING/DAMAGED PAVEMENT MARKINGS AND MARKERS BY THE END OF EACH DAY OPERATION.
- D. STOP BAR LOCATIONS AT NON-SIGNALIZED INTERSECTIONS MAY BE ADJUSTED AS DIRECTED BY THE ENGINEER.
- E. REMOVE ALL RESIDUE AND SURFACE LAITANCE BY ACCEPTABLE METHODS ON CONCRETE BRIDGE DECKS PRIOR TO PLACING POLYUREA PAVEMENT MARKING MATERIAL.
- F. SEE ROADWAY PLANS FOR ALTERNATE CURB RAMP DESIGN WHEN INDICATED ON PAVEMENT MARKING DETAIL SHEETS.

PAVEMENT MARKING SCHEDULE

THERMOPLASTIC LINES

- T1 WHITE EDGELINE (4", 90 MIL)
- T2 WHITE SOLID LANE LINE (4", 90 MIL)
- T4 3FT.-9FT./SP WHITE MINISKIP (4", 90 MIL)
- T5 2FT.-6FT./SP WHITE MINISKIP (4", 90 MIL)
- T10 YELLOW EDGELINE (4", 90 MIL)
- T11 YELLOW SINGLE CENTER (4", 90 MIL)
- T12 10FT. YELLOW SKIP (4", 90 MIL)
- T13 YELLOW DOUBLE CENTER (4", 90 MIL)
- T20 WHITE EDGELINE (6", 90 MIL)
- T21 WHITE SOLID LANE LINE (6", 90 MIL)
- T22 10FT. WHITE SKIP (6", 90 MIL)
- T23 3FT.-9FT./SP WHITE MINISKIP (6", 90 MIL)
- T24 2FT.-6FT./SP WHITE MINISKIP (6", 90 MIL)
- T30 YELLOW EDGELINE (6", 90 MIL)
- T33 YELLOW DOUBLE CENTER (6", 90 MIL)
- T34 2FT.-6FT./SP YELLOW MINISKIP (6", 90 MIL)
- T42 YELLOW DIAGONAL (8", 90 MIL)
- T46 WHITE CROSSWALK LINE (8", 90 MIL)
- T50 WHITE GORELINE (12", 90 MIL)
- T51 WHITE DIAGONAL (12", 90 MIL)
- T52 YELLOW DIAGONAL (12", 90 MIL)
- T54 3FT.-9FT./SP WHITE MINISKIP (12", 90 MIL)
- T55 3FT.-3FT./SP WHITE MINISKIP (12", 90 MIL)
- T60 WHITE LINE, RR X (16", 90 MIL)
- T61 WHITE STOPBAR (24", 90 MIL)

THERMOPLASTIC SYMBOLS

- T70 LEFT TURN ARROW (90 MIL)
- T71 RIGHT TURN ARROW (90 MIL)
- T72 STRAIGHT ARROW (90 MIL)
- T77 U-TURN ARROW (90 MIL)
- T100 ALPHANUMERIC CHAR. (90 MIL)
- T103 24" YIELD LINE TRIANGLE (90 MIL)
- T111 FISH-HOOK LEFT/STRAIGHT ARROW (90 MIL)

PAVEMENT MARKERS

- MA PERMANENT RAISED (YELLOW & YELLOW)
- MB PERMANENT RAISED (CRYSTAL & RED)

PLAN PREPARED FOR: N.C.D.O.T. SIGNING AND DELINEATION UNIT

R. B. ROACH, P.E., CPM	STATE SIGNING & DELINEATION ENGINEER
MITCH EATON, PE	SIGNING & DELINEATION REGIONAL ENGINEER

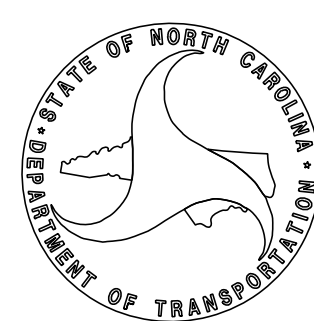

PLAN PREPARED BY :

RK&K
P: (919) 878-8560
8601 Six Forks Road, Forum 1, Suite 700
Raleigh, North Carolina 27615-3950
NC License No. F-0112

Engineers | Construction Managers | Planners | Scientists
www.rkk.com
Responsive People | Creative Solutions

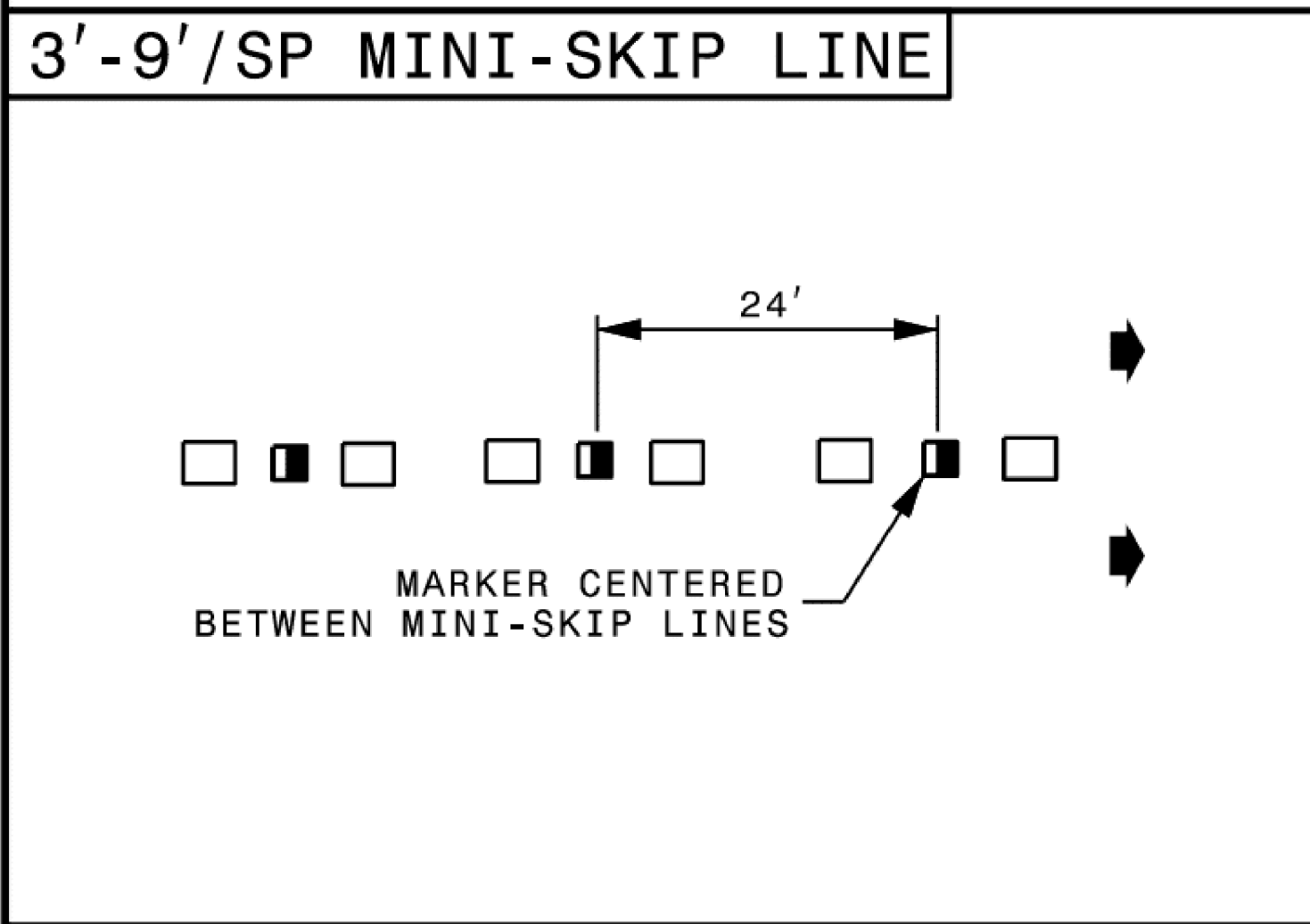
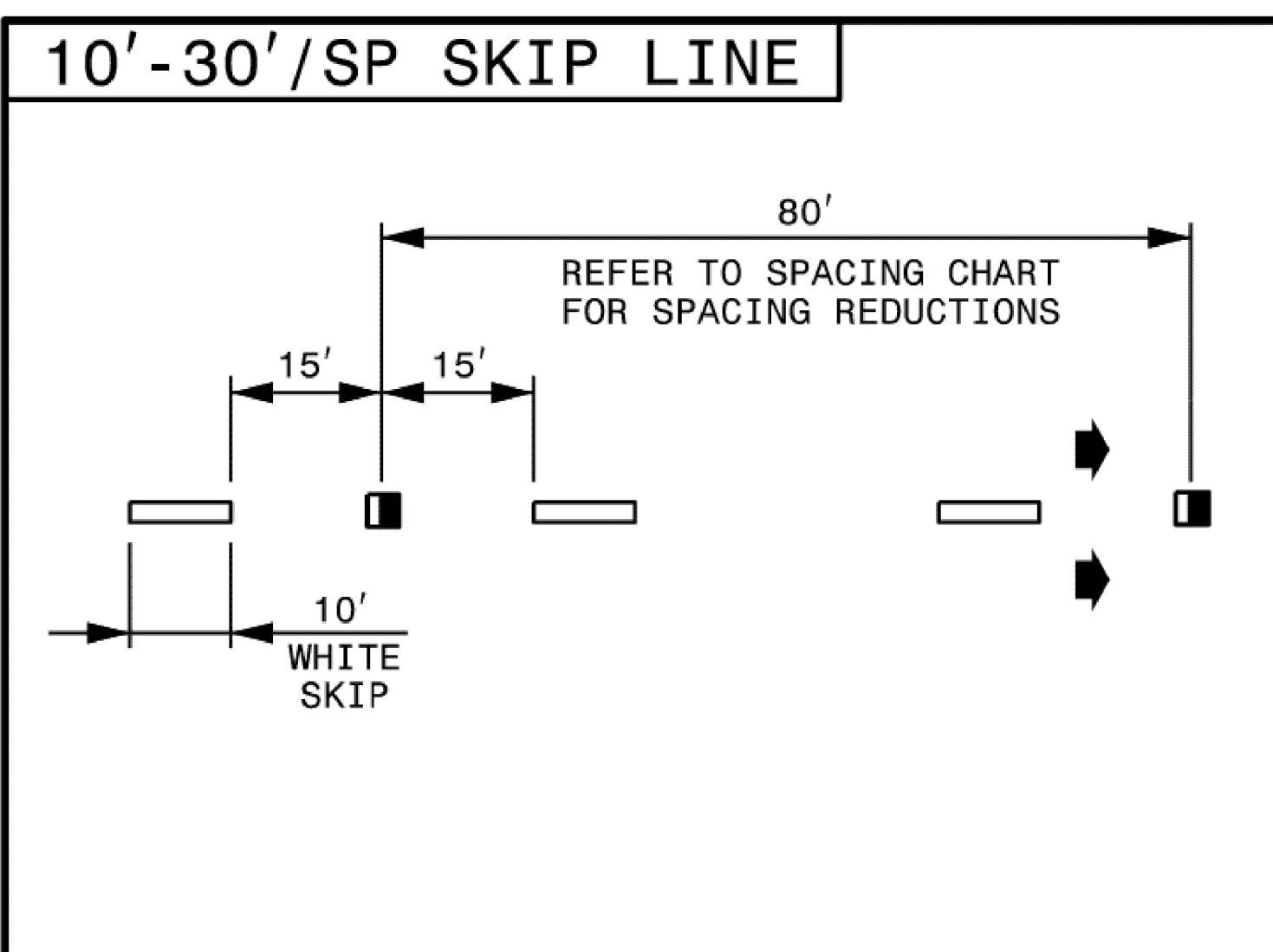

LEGEND

	CRYSTAL/RED PAVEMENT MARKER
	YELLOW/YELLOW PAVEMENT MARKER
	DIRECTION OF TRAFFIC FLOW

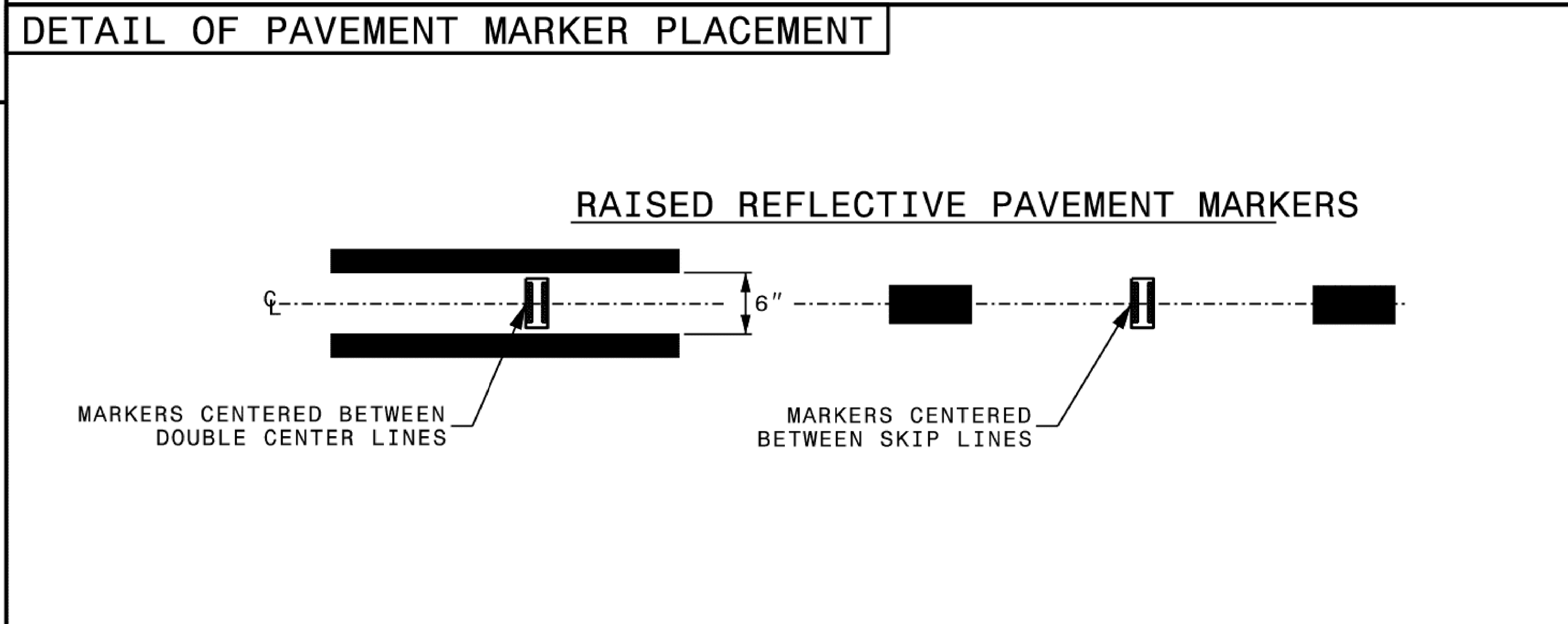
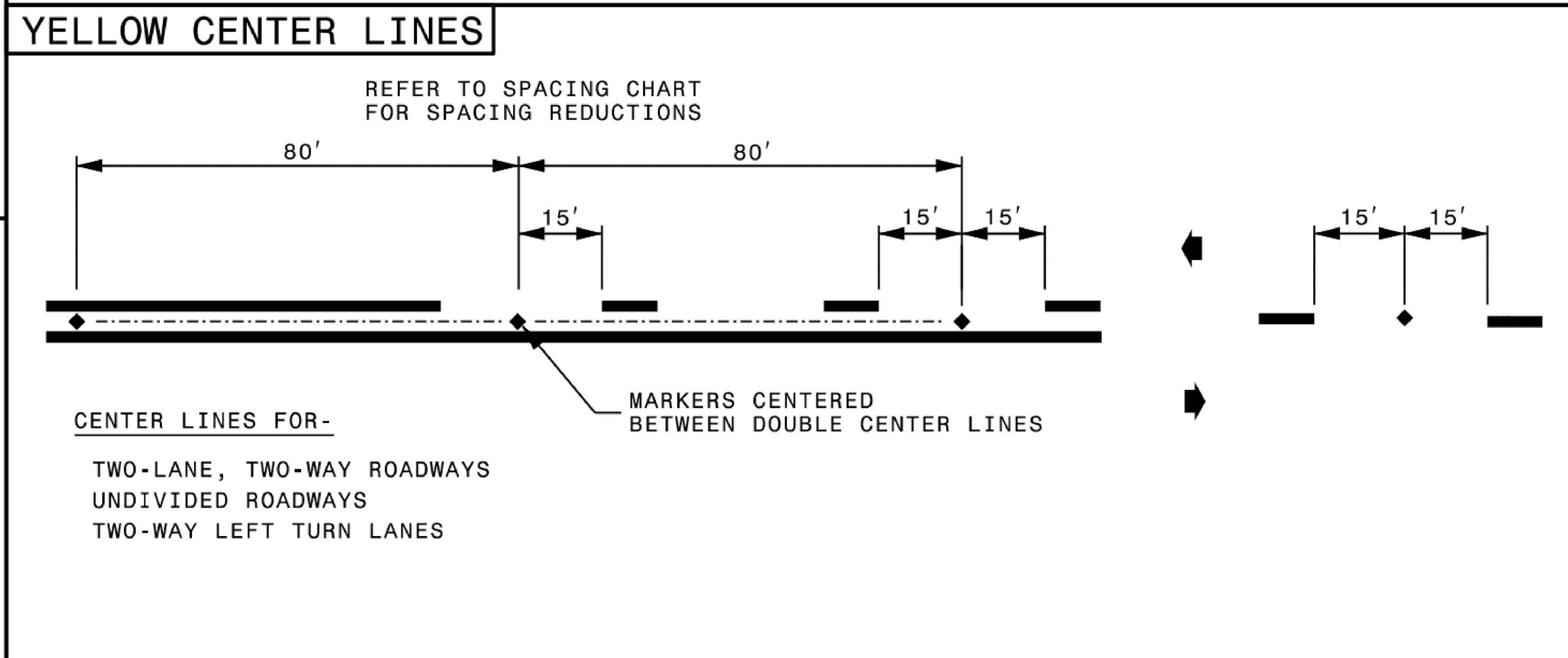
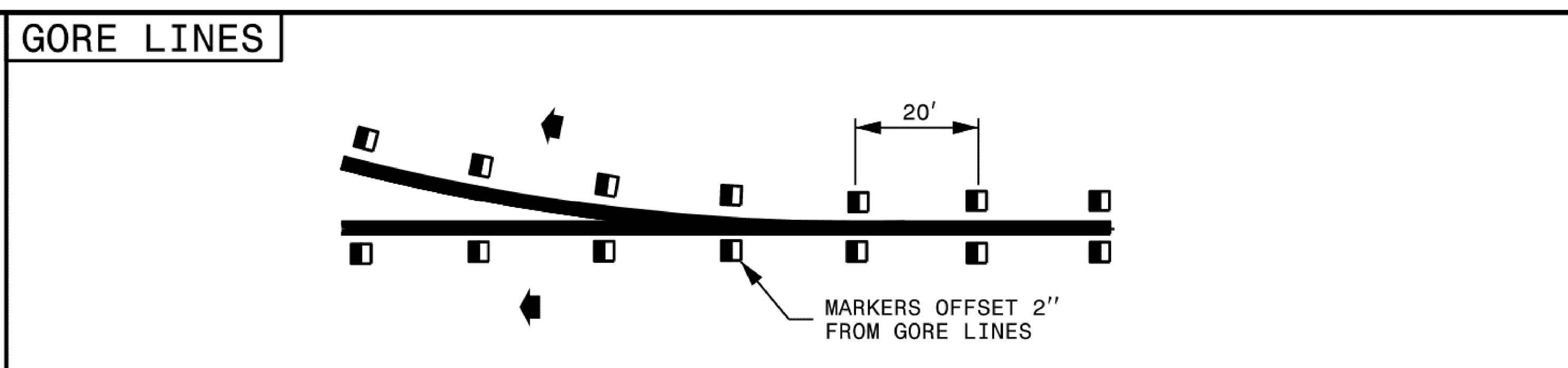

STATE OF NORTH CAROLINA
 DEPT. OF TRANSPORTATION
 DIVISION OF HIGHWAYS
 RALEIGH, N.C.

ROADWAY DETAIL DRAWING FOR
RAISED PAVEMENT MARKERS
 INSTALLATION SPACING

SHEET 2 OF 3
1250D01

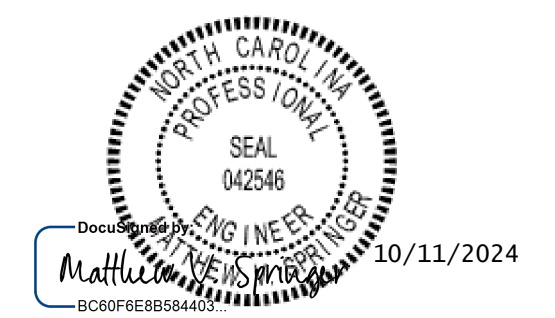

CONTRACTS STANDARDS AND DEVELOPMENT UNIT
 Office 919-707-8950 FAX 919-250-4119

SEE TITLE BLOCK

ORIGINAL BY: M.V. SPRINGER DATE: 2-15-24
 MODIFIED BY: _____ DATE: _____
 CHECKED BY: _____ DATE: _____
 FILE SPEC.: _____

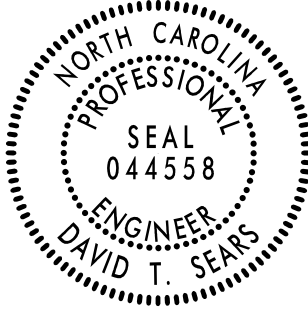
PROJECT REFERENCE NO. R-5709C	SHEET NO. PMP-2
APPROVED: <i>David T. Sears</i> 08183F28E5741E 10/11/2024	
DATE: 10/11/2024	
SEAL	
	
DOCUMENT NOT CONSIDERED FINAL UNLESS ALL SIGNATURES COMPLETED	

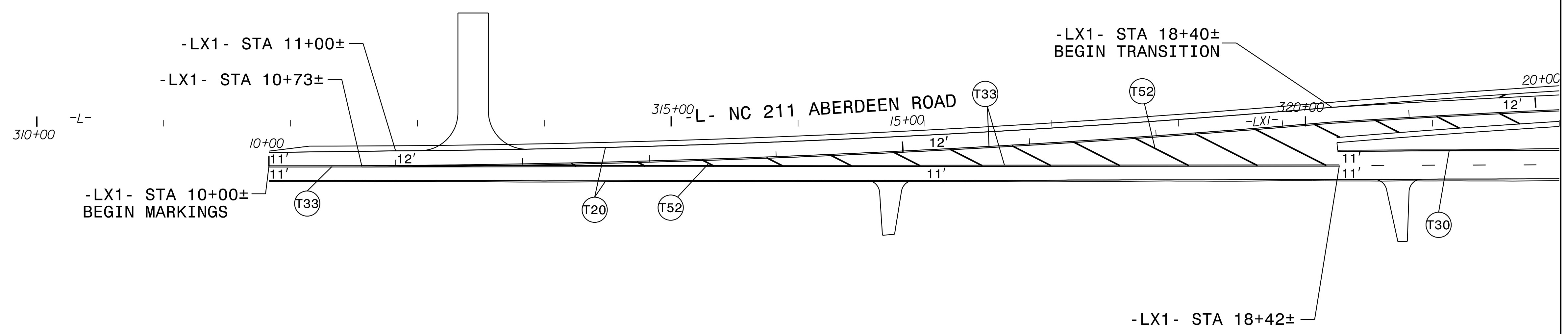

8/29/2024 R5709C_NC211_PMP_PSH_2.dgn

RK&K
 P: (919) 878-9560
 8601 Six Forks Road, Forum 1, Suite 700
 Raleigh, North Carolina 27615-3960
 NC License No. F-0112

Engineers | Construction Managers | Planners | Scientists
 www.rkk.com

Responsive People | Creative Solutions

PAVEMENT MARKING DETAIL

PROJECT REFERENCE NO. R-5709C	SHEET NO. PMP-3
APPROVED: <i>David T. Sears</i> <small>08183F28E5741E</small> DATE: 10/11/2024	
SEAL 	
DOCUMENT NOT CONSIDERED FINAL UNLESS ALL SIGNATURES COMPLETED	

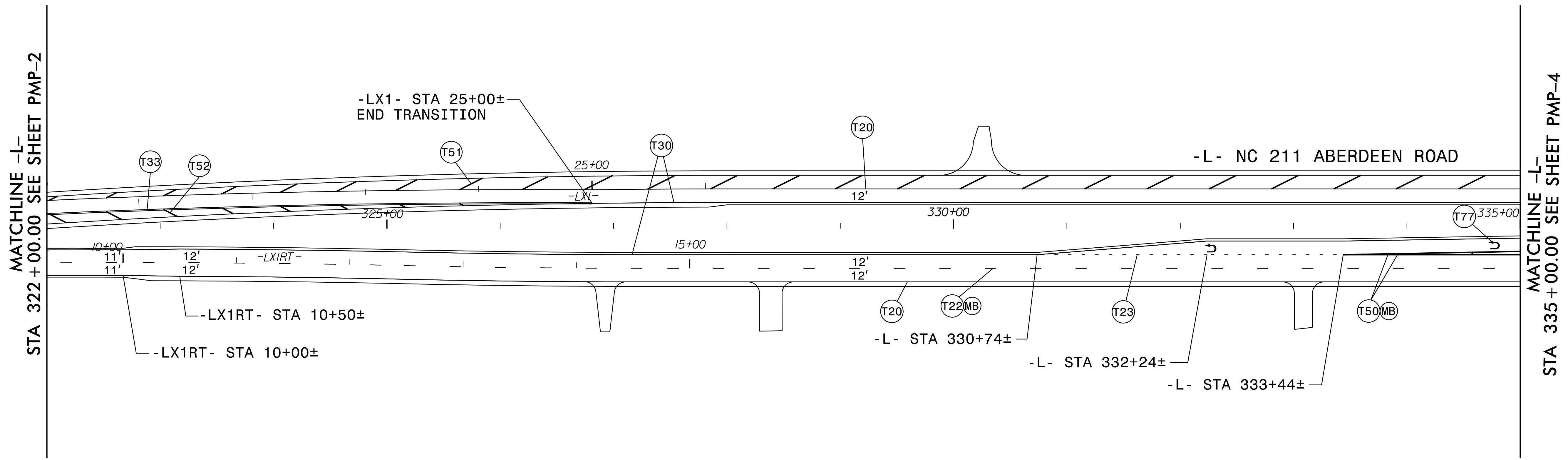
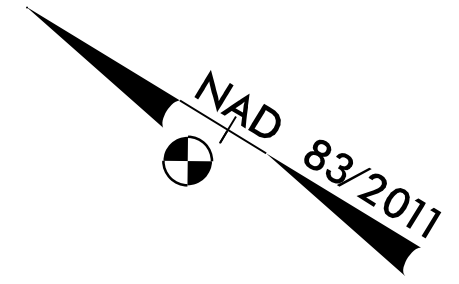

8/29/2024
R5709C_NC211_PMP_PSH_3.dgn



P: (919) 878-9560
 8601 Six Forks Road, Forum 1, Suite 700
 Raleigh, North Carolina 27615-3960
 NC License No. F-0112

Engineers | Construction Managers | Planners | Scientists
 www.rkk.com

Responsive People | Creative Solutions

PAVEMENT MARKING DETAIL

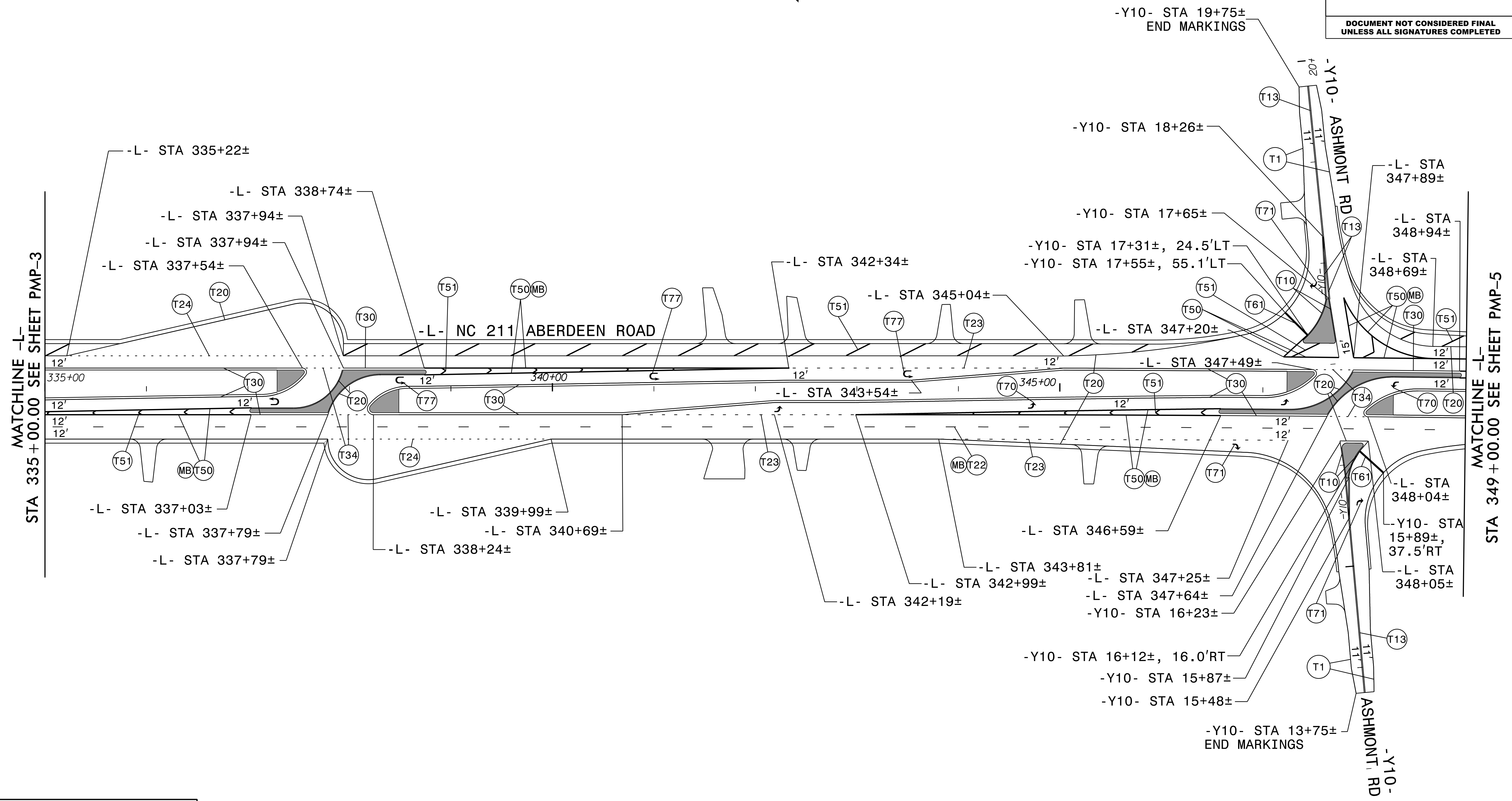
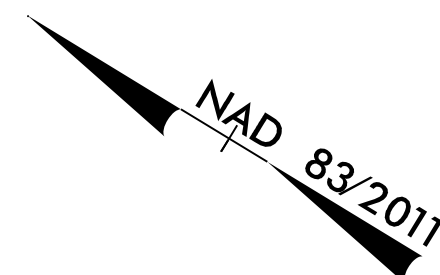

PAVEMENT MARKING DETAIL

PROJECT REFERENCE NO. R - 5709C	SHEET NO. PMP - 5
APPROVED: <i>David T. Sears</i> 08183F2B5741E 10/11/2024	
DATE: 10/11/2024	
SEAL	
	
DOCUMENT NOT CONSIDERED FINAL UNLESS ALL SIGNATURES COMPLETED	

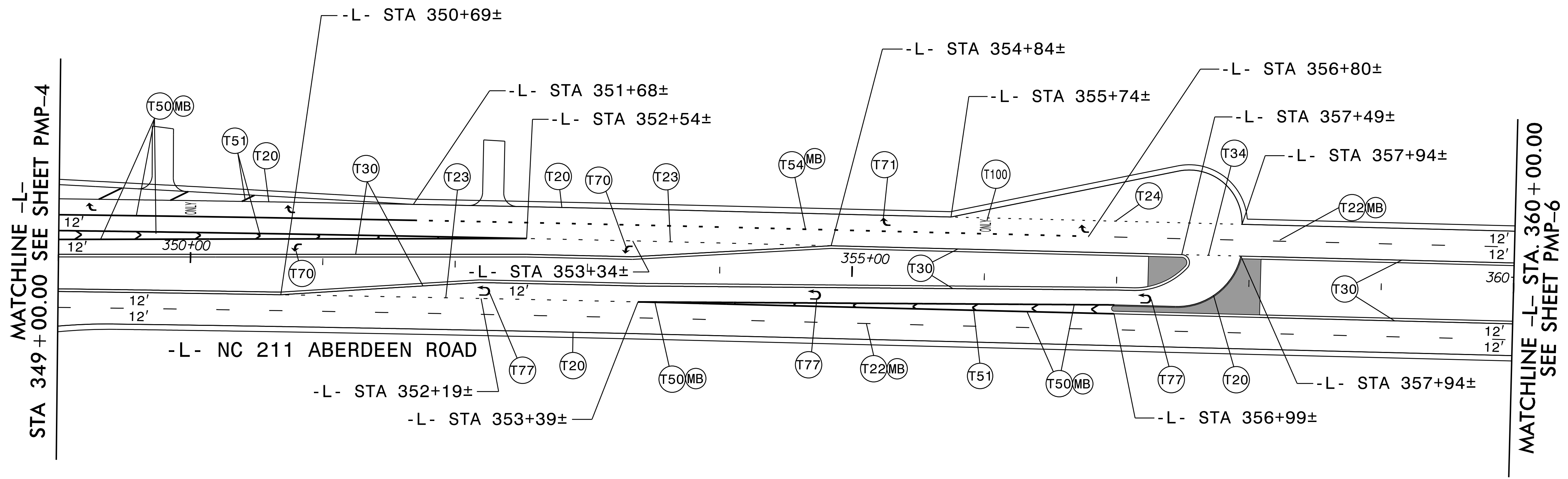
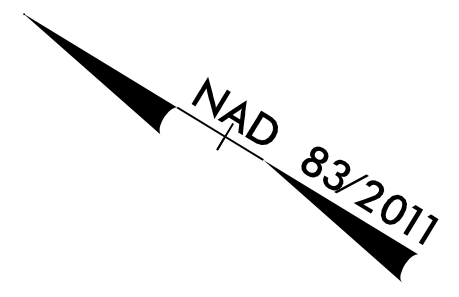

8/29/2024
R5709C_NC211_PMP_PSH_5.dgn

RK&K
 P: (919) 878-9560
 8601 Six Forks Road, Forum 1, Suite 700
 Raleigh, North Carolina 27615-3960
 NC License No. F-0112

Engineers | Construction Managers | Planners | Scientists
 www.rkk.com

Responsive People | Creative Solutions

PAVEMENT MARKING DETAIL

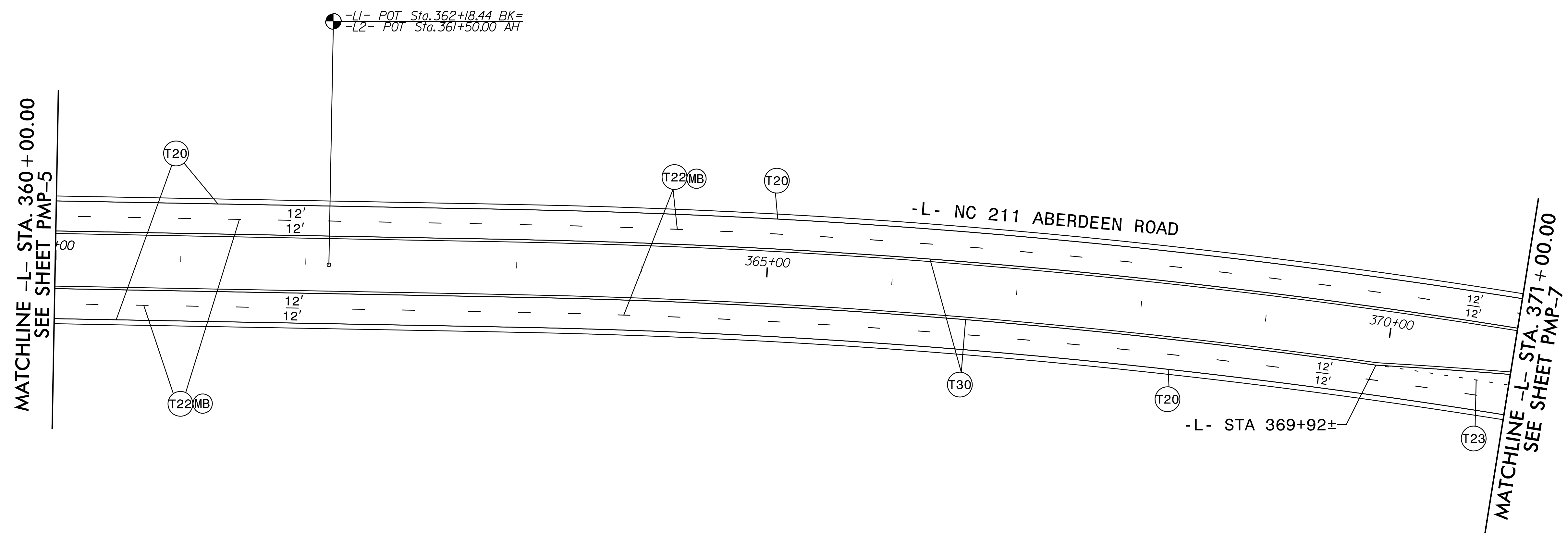

8/29/2024
 R5709C_NC211_PMP_PSH_6.dgn

RK&K
 P: (919) 878-9560
 8601 Six Forks Road, Forum 1, Suite 700
 Raleigh, North Carolina 27615-3960
 NC License No. F-0112

Engineers | Construction Managers | Planners | Scientists
 www.rkk.com

Responsive People | Creative Solutions

PAVEMENT MARKING DETAIL

PROJECT REFERENCE NO. R - 5709C	SHEET NO. PMP - 7
APPROVED: <i>David T. Sears</i> 08183F28E5741E 10/11/2024	
DATE: 10/11/2024	
SEAL	
	
DOCUMENT NOT CONSIDERED FINAL UNLESS ALL SIGNATURES COMPLETED	

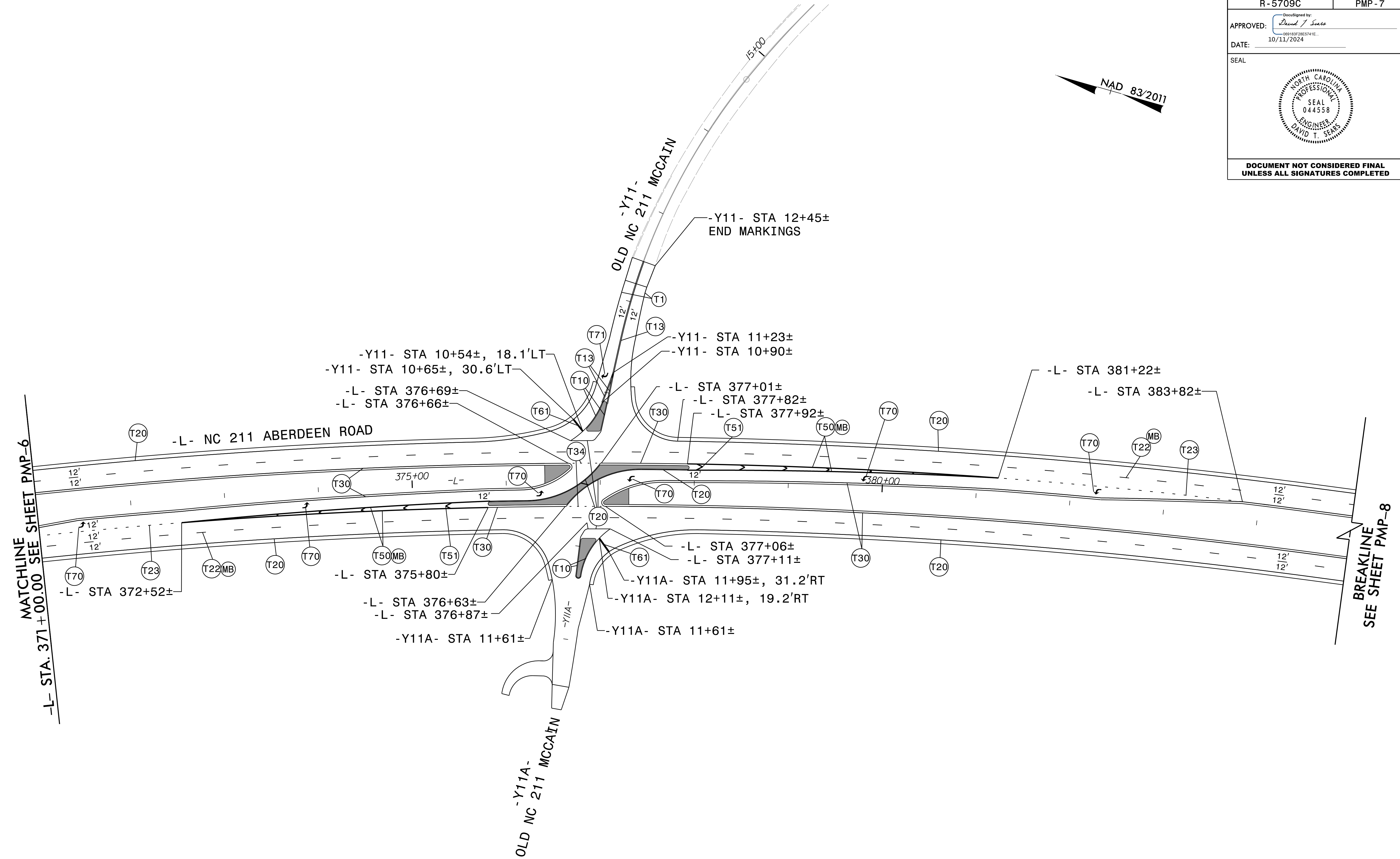

8/29/2024
R5709C_NC211_PMP_PSH_7.dgn

RK&K
 P: (919) 878-9560
 8601 Six Forks Road, Forum 1, Suite 700
 Raleigh, North Carolina 27615-3960
 NC License No. F-9112

Engineers | Construction Managers | Planners | Scientists
 www.rkk.com

Responsive People | Creative Solutions

PAVEMENT MARKING DETAIL

PROJECT REFERENCE NO. R-5709C	SHEET NO. PMP-8
APPROVED: <i>David T. Sears</i> 08183F28E5741E 10/11/2024	
DATE: 10/11/2024	
SEAL	
	
DOCUMENT NOT CONSIDERED FINAL UNLESS ALL SIGNATURES COMPLETED	

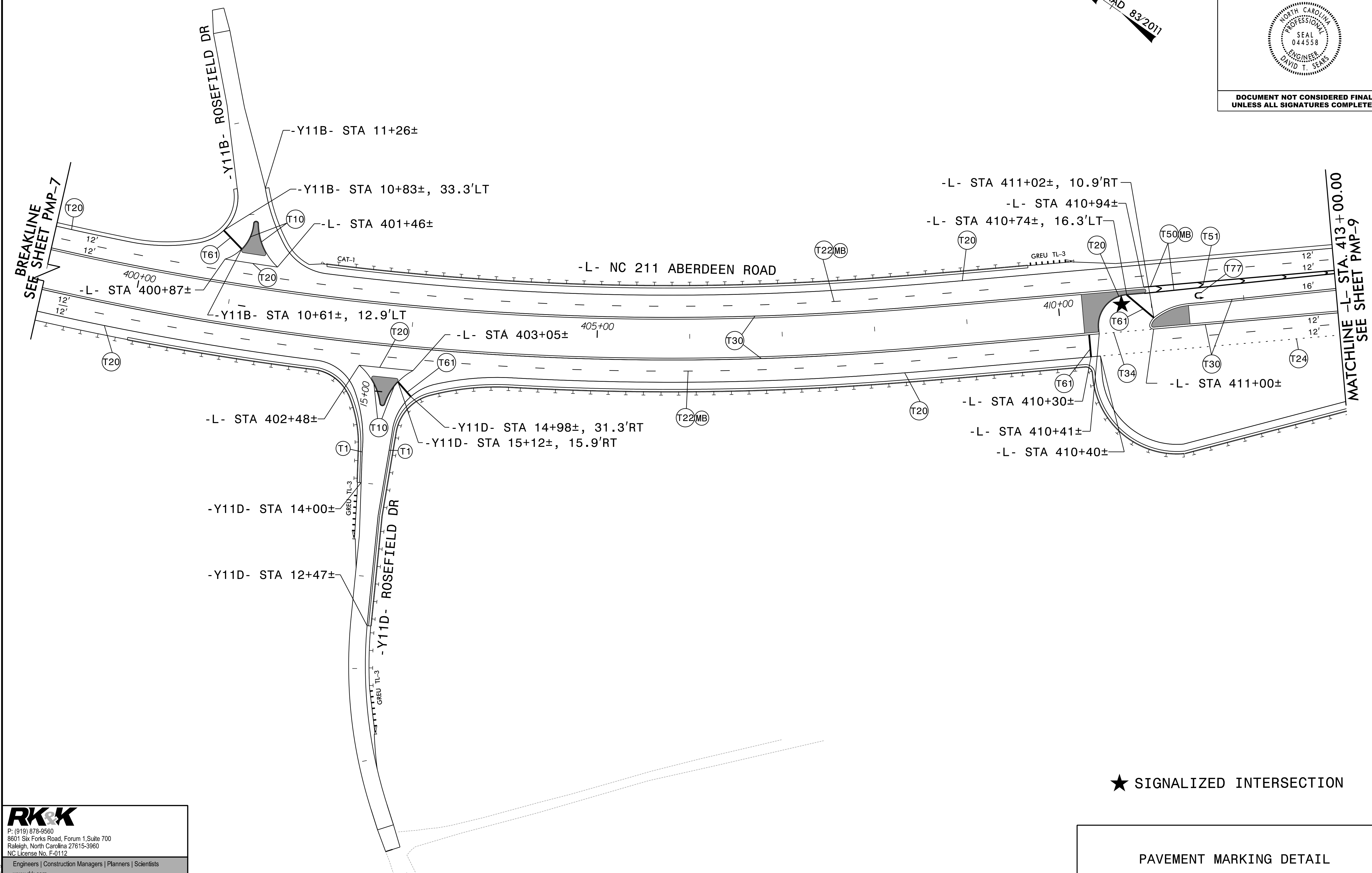
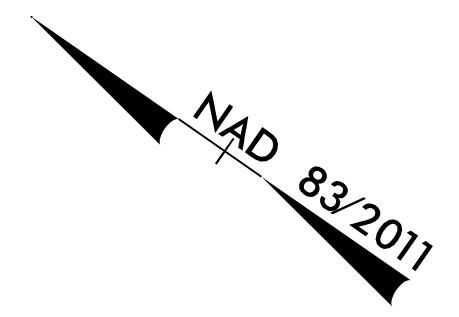

★ SIGNALIZED INTERSECTION

PAVEMENT MARKING DETAIL

RK&K
 P: (919) 878-9560
 8601 Six Forks Road, Forum 1, Suite 700
 Raleigh, North Carolina 27615-3960
 NC License No. F-9112

Engineers | Construction Managers | Planners | Scientists
 www.rkk.com

Responsive People | Creative Solutions

8/29/2024 R5709C_NC211_PMP_PSH_B.dgn

PROJECT REFERENCE NO. R-5709C	SHEET NO. PMP-9
APPROVED: <i>David T. Sears</i> 06183F28E5741E 10/11/2024	
DATE: 10/11/2024	
SEAL	
	
DOCUMENT NOT CONSIDERED FINAL UNLESS ALL SIGNATURES COMPLETED	

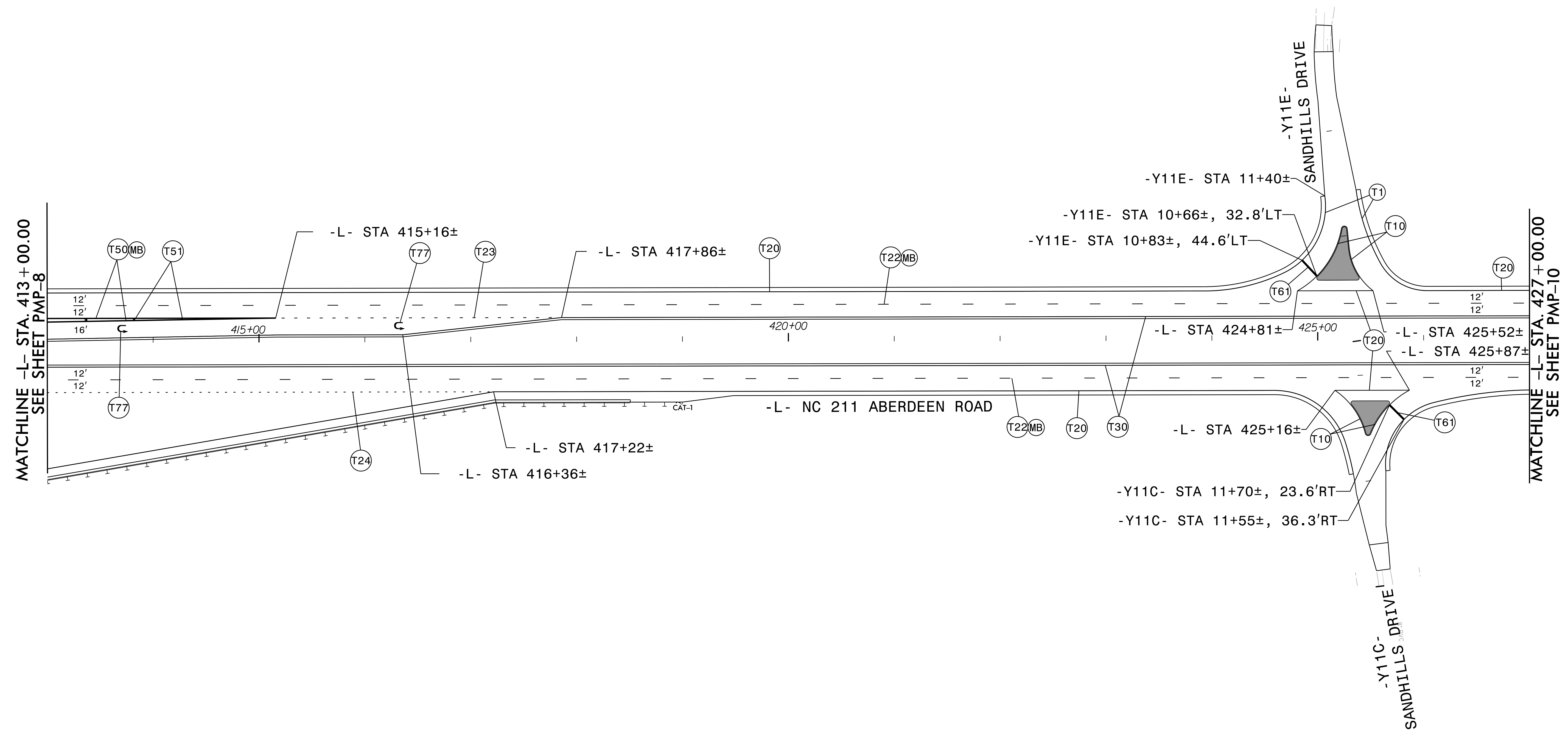
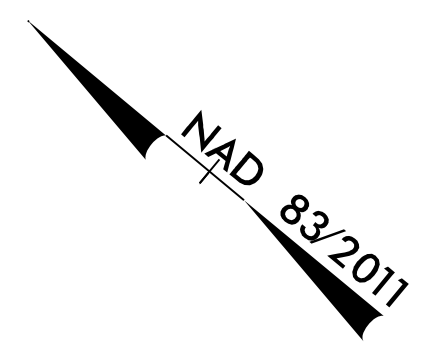

8/29/2024 R5709C_NC211_PMP_PSH_9.dgn

RK&K
P: (919) 878-9560
8601 Six Forks Road, Forum 1, Suite 700
Raleigh, North Carolina 27615-3960
NC License No. F-0112

Engineers | Construction Managers | Planners | Scientists
www.rkk.com

Responsive People | Creative Solutions

PAVEMENT MARKING DETAIL

PROJECT REFERENCE NO. R-5709C	SHEET NO. PMP-10
APPROVED: <i>David T. Sears</i> 08183F28E5741E 10/11/2024	
DATE: 10/11/2024	
SEAL	
	
DOCUMENT NOT CONSIDERED FINAL UNLESS ALL SIGNATURES COMPLETED	

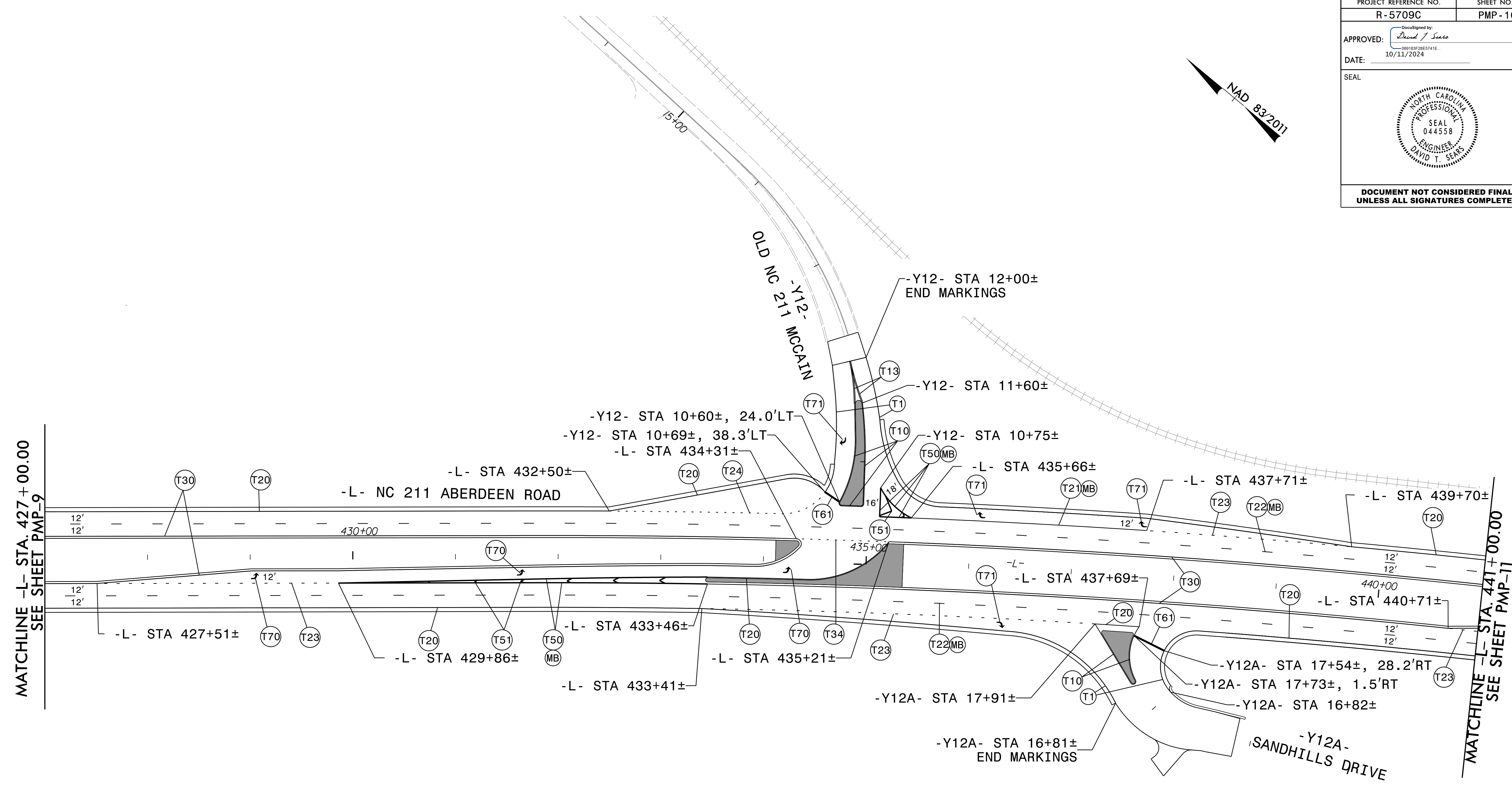
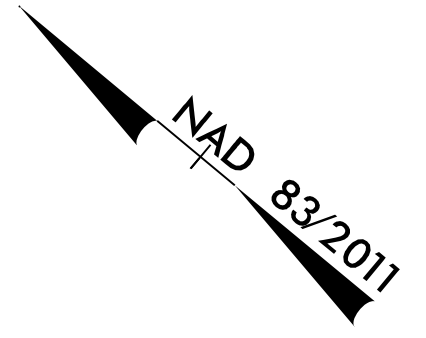

8/29/2024
R5709C_NC211_PMP_PSH_10.dgn

RK&K
 P: (919) 878-9560
 8601 Six Forks Road, Forum 1, Suite 700
 Raleigh, North Carolina 27615-3960
 NC License No. F-9112
 Engineers | Construction Managers | Planners | Scientists
 www.rkk.com
 Responsive People | Creative Solutions

PAVEMENT MARKING DETAIL

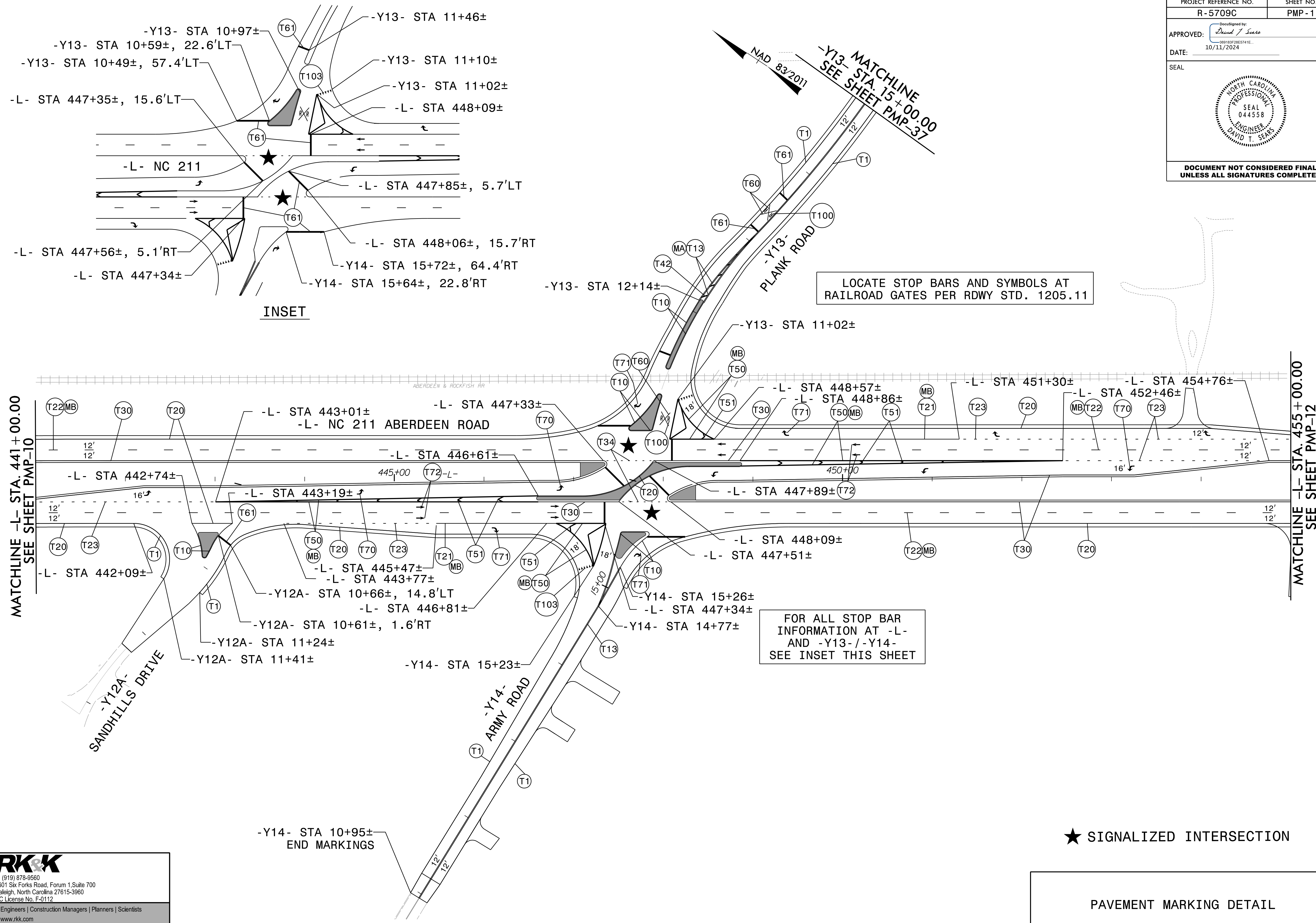

MATCHLINE -L- STA. 441+00.00
SEE SHEET PMP-10

MATCHLINE -L- STA. 455+00.00
SEE SHEET PMP-12

INSET

LOCATE STOP BARS AND SYMBOLS AT
RAILROAD GATES PER RDWY STD. 1205.11

FOR ALL STOP BAR
INFORMATION AT -L-
AND -Y13-/-Y14-
SEE INSET THIS SHEET

★ SIGNALIZED INTERSECTION

PAVEMENT MARKING DETAIL

PROJECT REFERENCE NO. R - 5709C	SHEET NO. PMP - 12
APPROVED: <i>David T. Sears</i> 060183F28E5741E 10/11/2024	
DATE: 10/11/2024	
SEAL 	
DOCUMENT NOT CONSIDERED FINAL UNLESS ALL SIGNATURES COMPLETED	

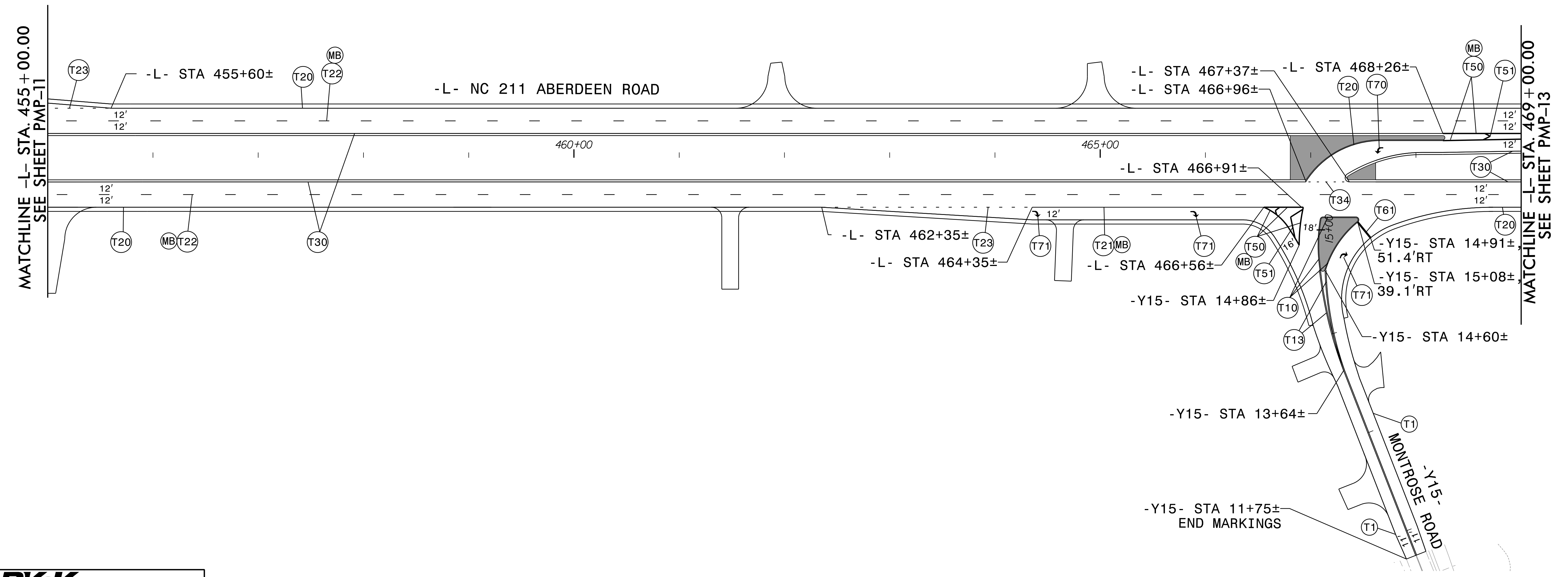
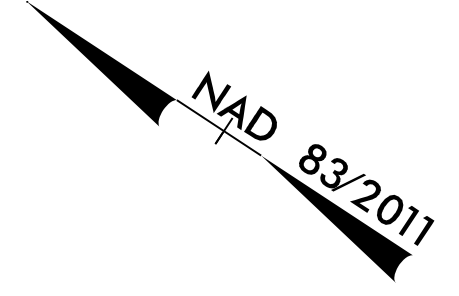

8/29/2024
R5709C_NC211_PMP_PSH_12.dgn

RK&K
 P: (919) 878-9560
 8601 Six Forks Road, Forum 1, Suite 700
 Raleigh, North Carolina 27615-3960
 NC License No. F-0112
 Engineers | Construction Managers | Planners | Scientists
 www.rkk.com
 Responsive People | Creative Solutions

PAVEMENT MARKING DETAIL

PROJECT REFERENCE NO. R-5709C	SHEET NO. PMP-13
APPROVED: <i>David T. Sears</i> 08183F28E5741E 10/11/2024	
DATE: 10/11/2024	
SEAL	
	
DOCUMENT NOT CONSIDERED FINAL UNLESS ALL SIGNATURES COMPLETED	

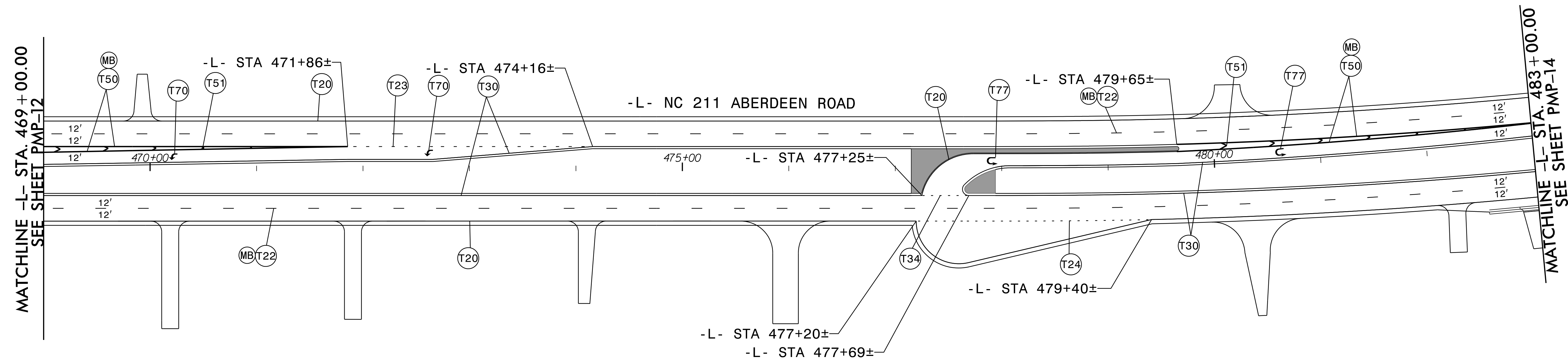
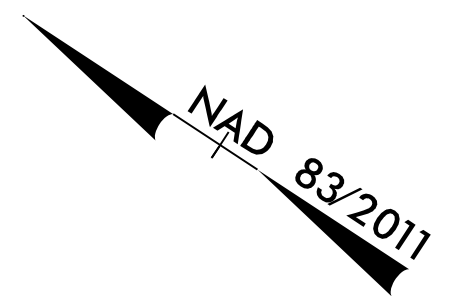

8/29/2024 R5709C_NC211_PMP_PSH_13.dgn

RK&K
 P: (919) 878-9560
 8601 Six Forks Road, Forum 1, Suite 700
 Raleigh, North Carolina 27615-3960
 NC License No. F-0112
 Engineers | Construction Managers | Planners | Scientists
 www.rkk.com
 Responsive People | Creative Solutions

PAVEMENT MARKING DETAIL

PROJECT REFERENCE NO. R - 5709C	SHEET NO. PMP - 14
APPROVED: <i>David T. Sears</i> <small>08183F2B5741E</small> DATE: 10/11/2024	
SEAL 	
DOCUMENT NOT CONSIDERED FINAL UNLESS ALL SIGNATURES COMPLETED	

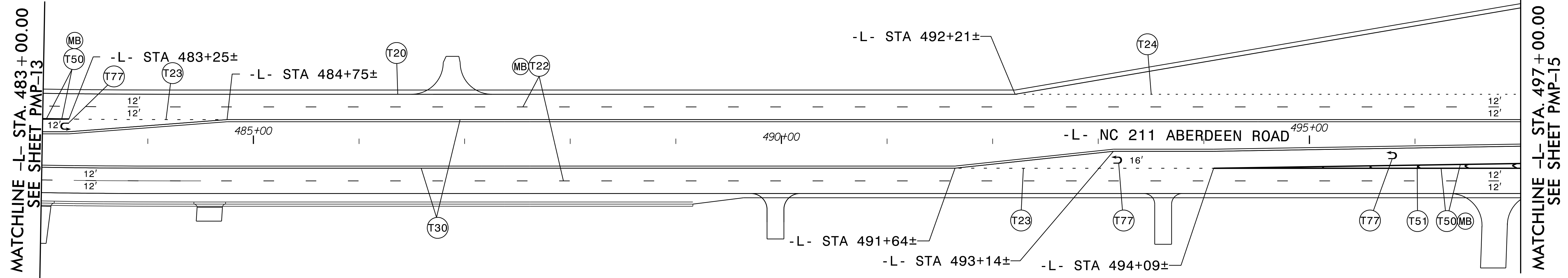
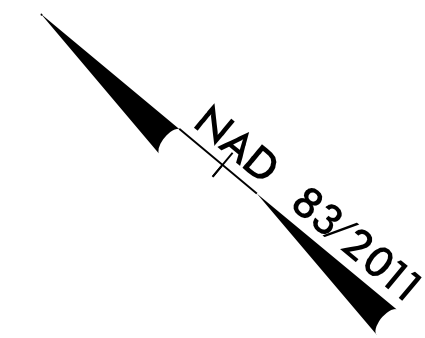

8/29/2024 R5709C_NC211_PMP_PSH_14.dgn

RK&K
 P: (919) 878-9560
 8601 Six Forks Road, Forum 1, Suite 700
 Raleigh, North Carolina 27615-3960
 NC License No. F-0112

Engineers | Construction Managers | Planners | Scientists
 www.rkk.com

Responsive People | Creative Solutions

PAVEMENT MARKING DETAIL

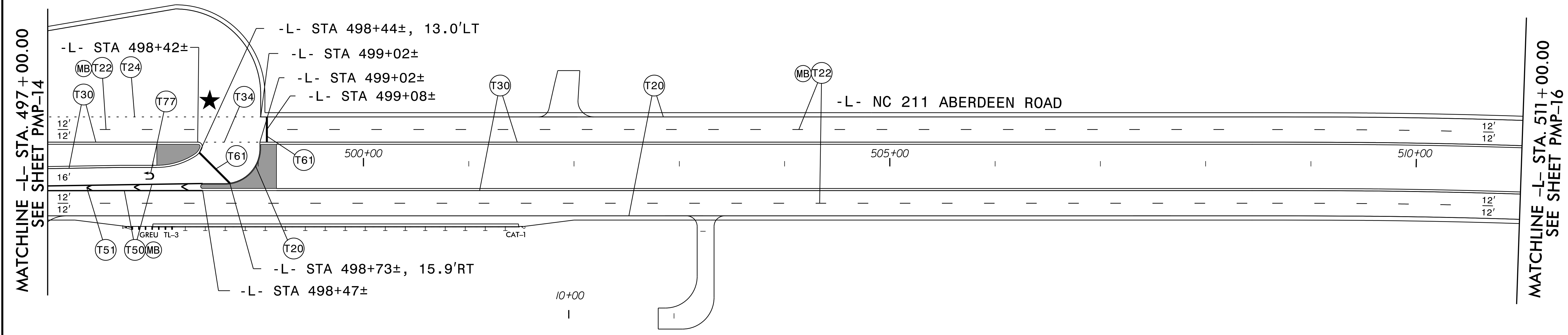

MATCHLINE -L- STA. 497 + 00.00
SEE SHEET PMP-14

MATCHLINE -L- STA. 511 + 00.00
SEE SHEET PMP-16

★ SIGNALIZED INTERSECTION

PAVEMENT MARKING DETAIL

PROJECT REFERENCE NO. R-5709C	SHEET NO. PMP-16
APPROVED: <i>David T. Sears</i> 08183F28E5741E	
DATE: 10/11/2024	
SEAL	
	
DOCUMENT NOT CONSIDERED FINAL UNLESS ALL SIGNATURES COMPLETED	

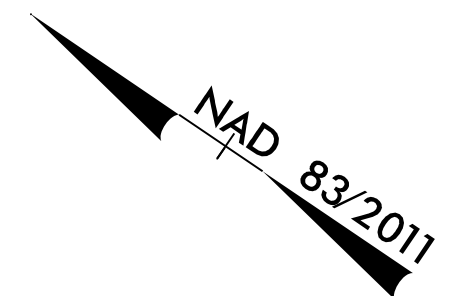

MATCHLINE -L- STA. 511 + 00.00
SEE SHEET PMP-15

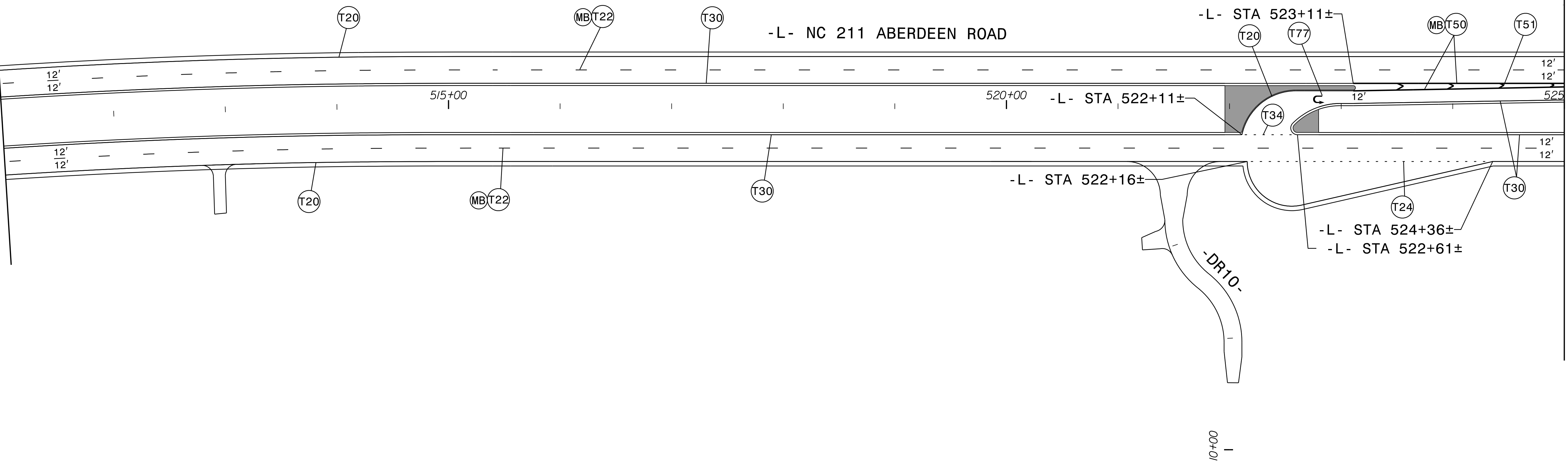

MATCHLINE -L- STA. 525 + 00.00 SEE SHEET PMP-17

8/29/2024
R5709C_NC211_PMP_PSH_16.dgn

RK&K
 P: (919) 878-9560
 8601 Six Forks Road, Forum 1, Suite 700
 Raleigh, North Carolina 27615-3960
 NC License No. F-0112
 Engineers | Construction Managers | Planners | Scientists
 www.rkk.com
 Responsive People | Creative Solutions

PAVEMENT MARKING DETAIL

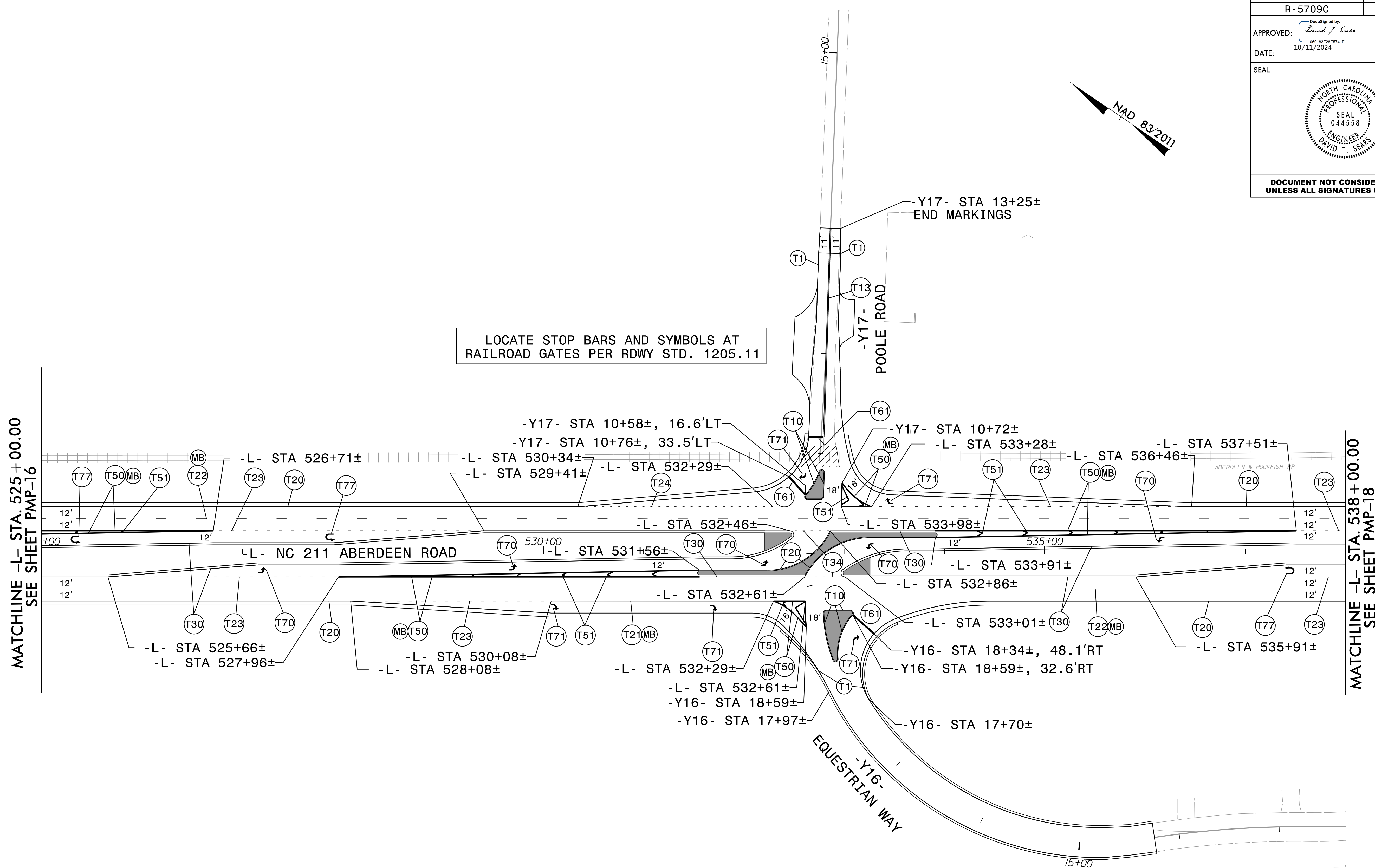
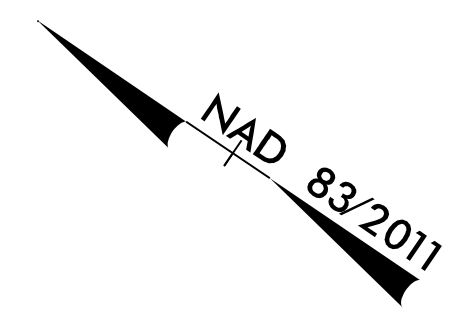

LOCATE STOP BARS AND SYMBOLS AT
RAILROAD GATES PER RDWY STD. 1205.11

MATCHLINE -L- STA. 525+00.00
SEE SHEET PMP-16

MATCHLINE -L- STA. 538+00.00
SEE SHEET PMP-18

8/29/2024
R5709C_NC211_PMP_PSH_17.dgn

RK&K
 P: (919) 878-9560
 8601 Six Forks Road, Forum 1, Suite 700
 Raleigh, North Carolina 27615-3960
 NC License No. F-9112
 Engineers | Construction Managers | Planners | Scientists
 www.rkk.com
 Responsive People | Creative Solutions

PAVEMENT MARKING DETAIL

PROJECT REFERENCE NO. R-5709C	SHEET NO. PMP-18
APPROVED: <i>David T. Sears</i> 08183F28E5741E 10/11/2024	
DATE: 10/11/2024	
SEAL 	
DOCUMENT NOT CONSIDERED FINAL UNLESS ALL SIGNATURES COMPLETED	

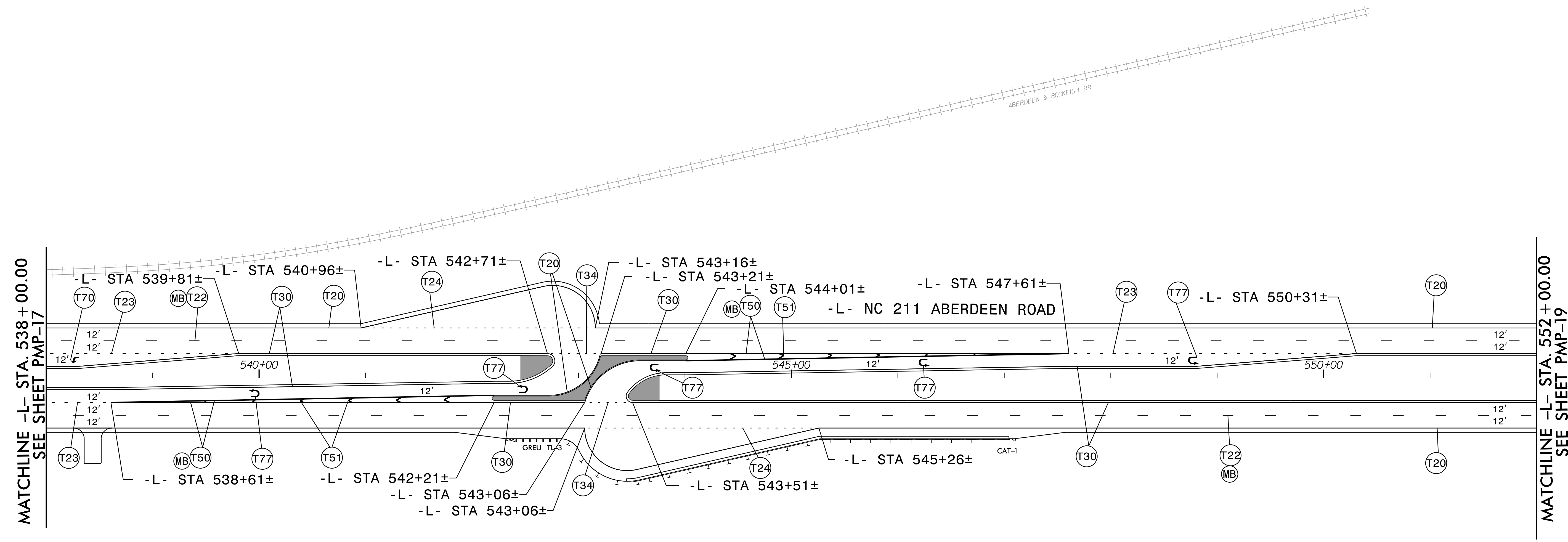
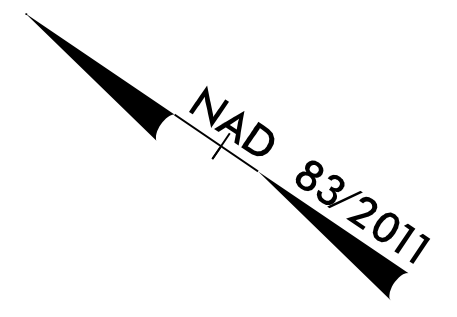

8/29/2024
R5709C_NC211_PMP_PSH_18.dgn

RK&K
 P: (919) 878-9560
 8601 Six Forks Road, Forum 1, Suite 700
 Raleigh, North Carolina 27615-3960
 NC License No. F-9112

Engineers | Construction Managers | Planners | Scientists
 www.rkk.com

Responsive People | Creative Solutions

PAVEMENT MARKING DETAIL

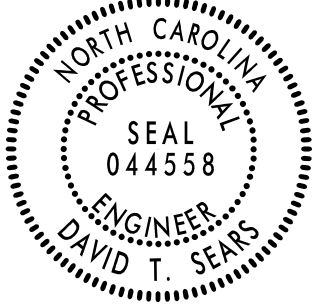
PROJECT REFERENCE NO. R - 5709C	SHEET NO. PMP - 19
APPROVED: <i>David T. Seans</i> <small>08183F2B5741E</small> DATE: 10/11/2024	
SEAL 	
DOCUMENT NOT CONSIDERED FINAL UNLESS ALL SIGNATURES COMPLETED	

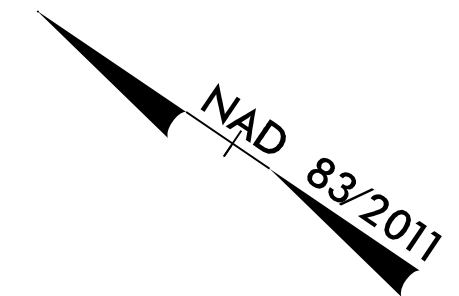

MATCHLINE -L- STA. 552 + 00.00
SEE SHEET PMP-18

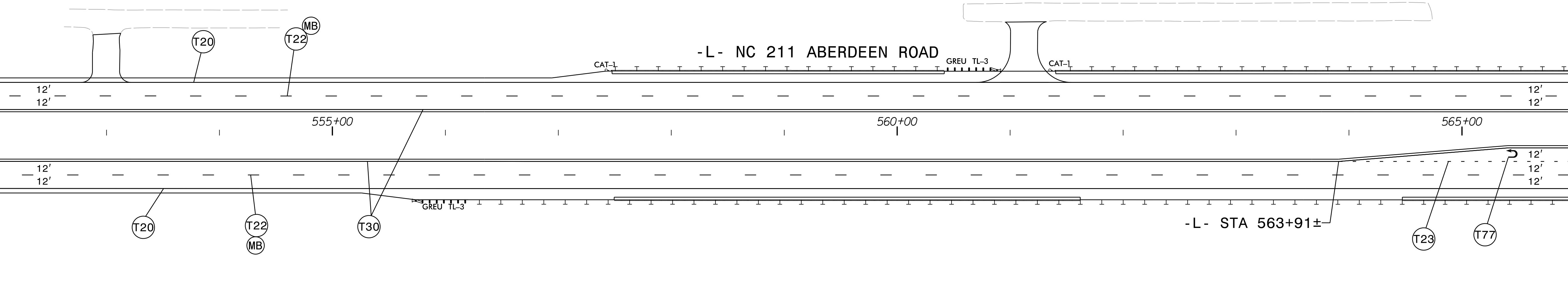

MATCHLINE -L- STA. 566 + 00.00
SEE SHEET PMP-20

8/29/2024
R5709C_NC211_PMP_PSH_19.dgn

RK&K
 P: (919) 878-9560
 8601 Six Forks Road, Forum 1, Suite 700
 Raleigh, North Carolina 27615-3960
 NC License No. F-0112
 Engineers | Construction Managers | Planners | Scientists
 www.rkk.com
 Responsive People | Creative Solutions

PAVEMENT MARKING DETAIL

PROJECT REFERENCE NO. R-5709C	SHEET NO. PMP-20
APPROVED: <i>David T. Sears</i> 08183F28E5741E 10/11/2024	
DATE: 10/11/2024	
SEAL	
	
DOCUMENT NOT CONSIDERED FINAL UNLESS ALL SIGNATURES COMPLETED	

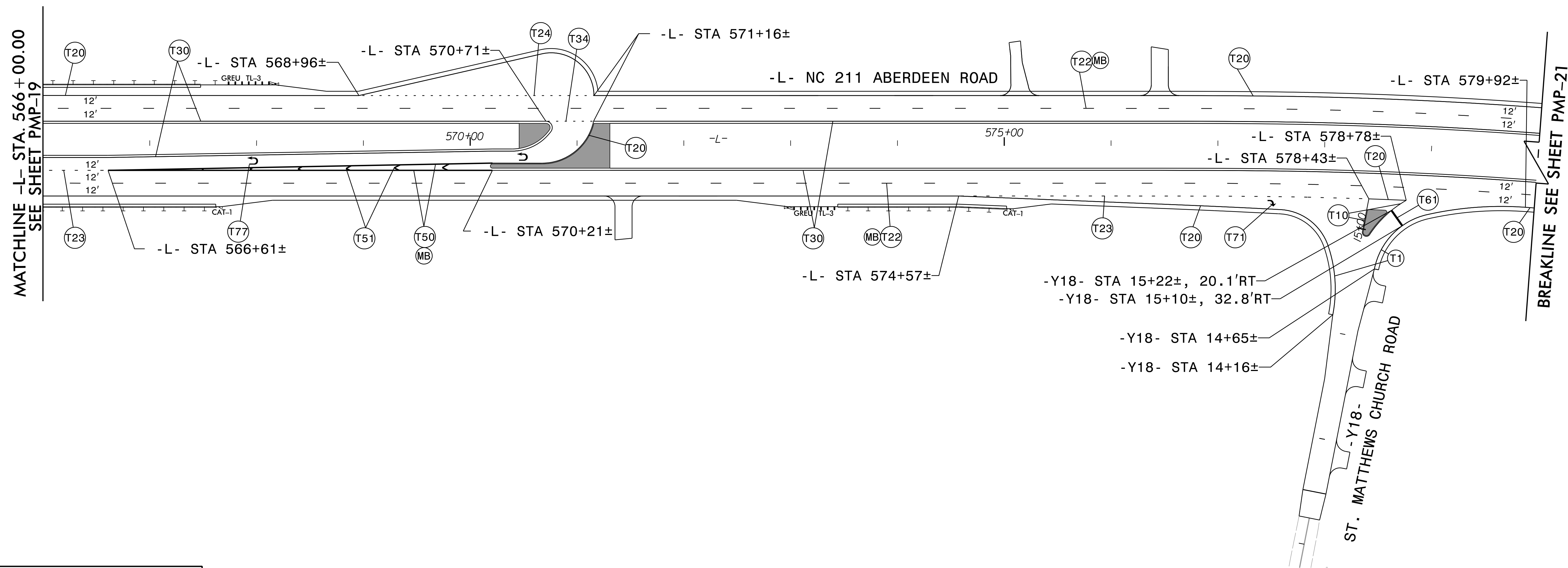
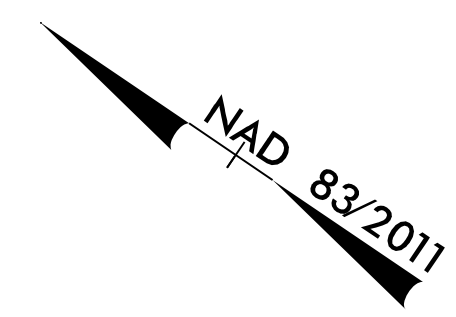

MATCHLINE -L- STA. 566+00.00
SEE SHEET PMP-19

BREAKLINE SEE SHEET PMP-21

ST. MATTHEWS CHURCH ROAD

PAVEMENT MARKING DETAIL

8/29/2024
R5709C_NC211_PMP_PSH_20.dgn



P: (919) 878-9560
8601 Six Forks Road, Forum 1, Suite 700
Raleigh, North Carolina 27615-3960
NC License No. F-0112

Engineers | Construction Managers | Planners | Scientists
www.rkk.com

Responsive People | Creative Solutions

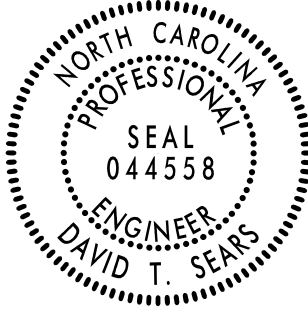
PROJECT REFERENCE NO. R-5709C	SHEET NO. PMP-21
APPROVED: <i>David T. Sears</i> 06183F2B5741E 10/11/2024	
DATE: 10/11/2024	
SEAL	
	
DOCUMENT NOT CONSIDERED FINAL UNLESS ALL SIGNATURES COMPLETED	

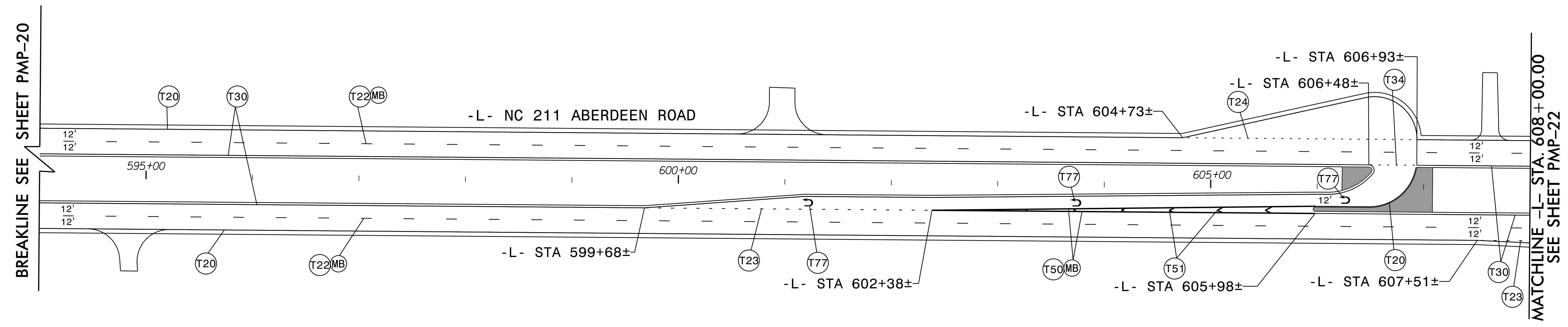
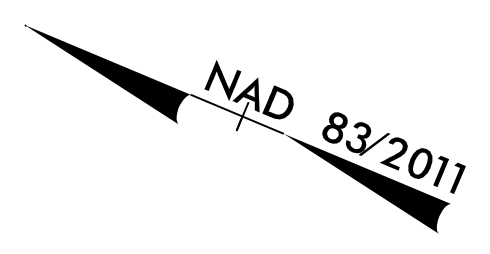

BREAKLINE SEE SHEET PMP-20

MATCHLINE -L- STA. 608+00.00
SEE SHEET PMP-22

8/29/2024 R5709C_NC211_PMP_PSH_21.dgn

RK&K
P: (919) 878-9560
8601 Six Forks Road, Forum 1, Suite 700
Raleigh, North Carolina 27615-3960
NC License No. F-0112
Engineers | Construction Managers | Planners | Scientists
www.rkk.com
Responsive People | Creative Solutions

PAVEMENT MARKING DETAIL

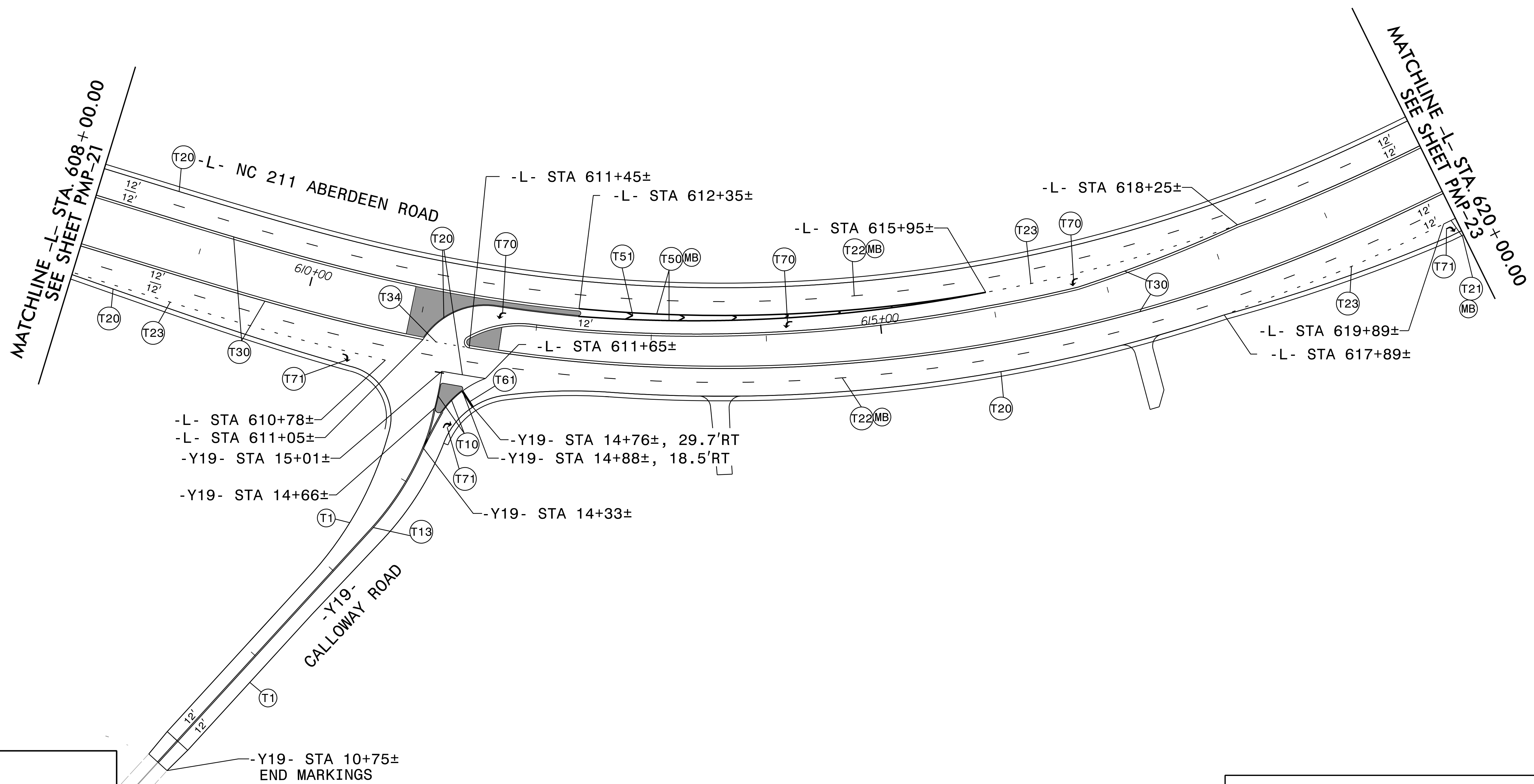
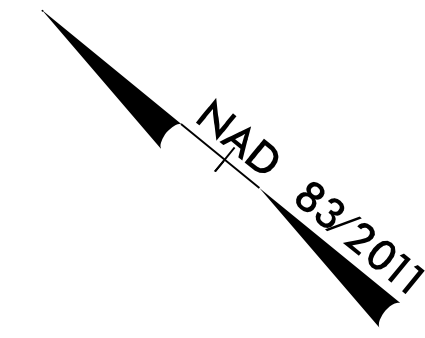

8/29/2024 R5709C_NC211_PMP_PSH_22.dgn

RK&K
 P: (919) 878-9560
 8601 Six Forks Road, Forum 1, Suite 700
 Raleigh, North Carolina 27615-3960
 NC License No. F-0112
 Engineers | Construction Managers | Planners | Scientists
 www.rkk.com
 Responsive People | Creative Solutions

PAVEMENT MARKING DETAIL

PROJECT REFERENCE NO. R - 5709C	SHEET NO. PMP - 23
APPROVED: <i>David T. Sears</i> 09183F2B5741E 10/11/2024	
DATE: 10/11/2024	
SEAL	
	
DOCUMENT NOT CONSIDERED FINAL UNLESS ALL SIGNATURES COMPLETED	

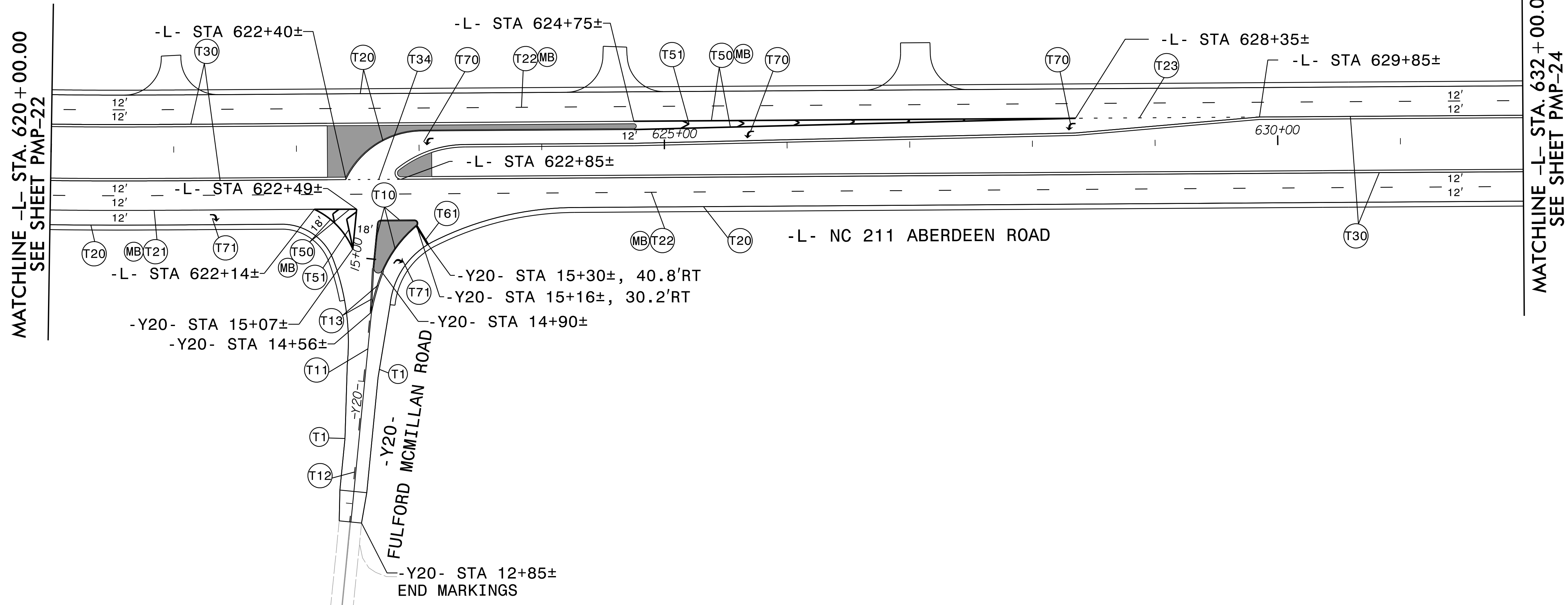
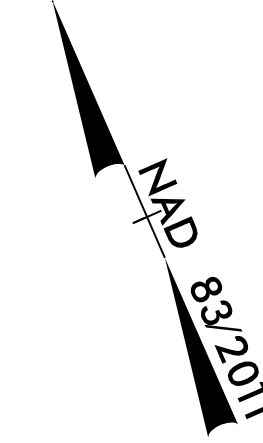

8/29/2024
R5709C_NC211_PMP_PSH_23.dgn

RK&K
 P: (919) 878-9560
 8601 Six Forks Road, Forum 1, Suite 700
 Raleigh, North Carolina 27615-3960
 NC License No. F-0112
 Engineers | Construction Managers | Planners | Scientists
 www.rkk.com
 Responsive People | Creative Solutions

PAVEMENT MARKING DETAIL

PROJECT REFERENCE NO. R - 5709C	SHEET NO. PMP - 24
APPROVED: <i>David T. Sears</i> <small>08183F28E5741E</small> DATE: 10/11/2024	
SEAL 	
DOCUMENT NOT CONSIDERED FINAL UNLESS ALL SIGNATURES COMPLETED	

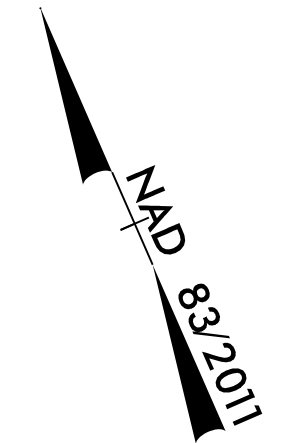

MATCHLINE -L- STA. 632+00.00
SEE SHEET PMP-23

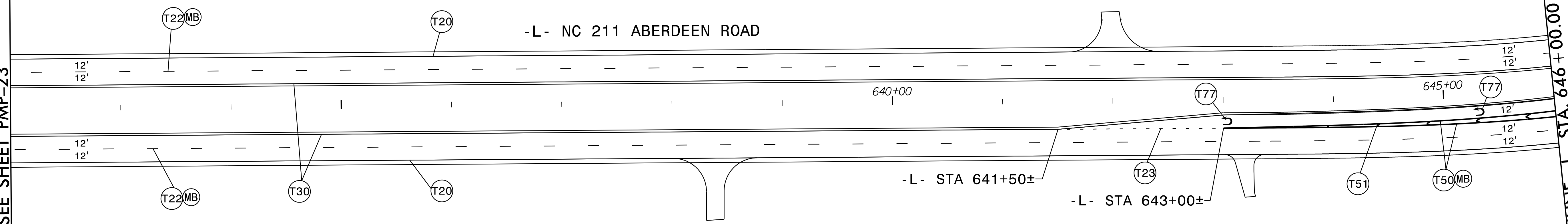

MATCHLINE -L- STA. 646+00.00 SEE SHEET PMP-25

8/29/2024
R5709C_NC211_PMP_PSH_24.dgn

RK&K
 P: (919) 878-9560
 8601 Six Forks Road, Forum 1, Suite 700
 Raleigh, North Carolina 27615-3960
 NC License No. F-0112

Engineers | Construction Managers | Planners | Scientists
 www.rkk.com

Responsive People | Creative Solutions

PAVEMENT MARKING DETAIL

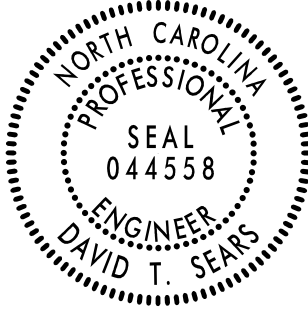
PROJECT REFERENCE NO. R - 5709C	SHEET NO. PMP - 25
APPROVED: <i>David T. Seans</i> 08183F28E5741E 10/11/2024	
DATE: 10/11/2024	
SEAL	
	
DOCUMENT NOT CONSIDERED FINAL UNLESS ALL SIGNATURES COMPLETED	

NAD 83/2011

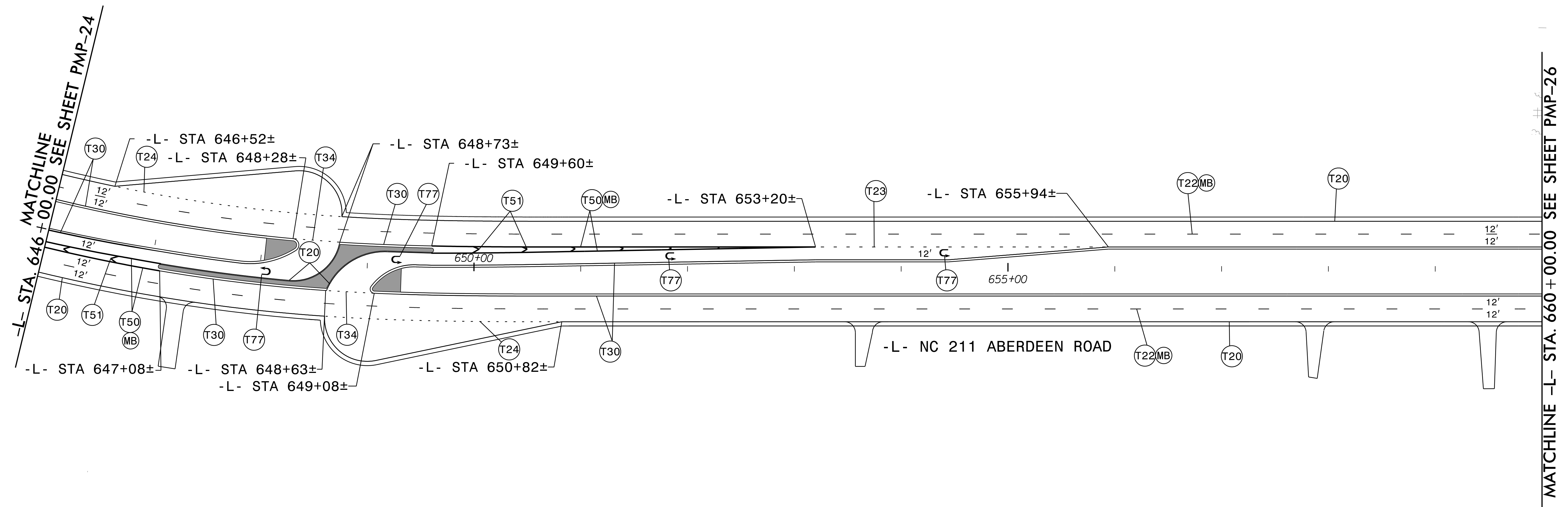

8/29/2024
R5709C_NC211_PMP_PSH_25.dgn

RK&K
 P: (919) 878-9560
 8601 Six Forks Road, Forum 1, Suite 700
 Raleigh, North Carolina 27615-3960
 NC License No. F-0112
 Engineers | Construction Managers | Planners | Scientists
 www.rkk.com
 Responsive People | Creative Solutions

PAVEMENT MARKING DETAIL

PROJECT REFERENCE NO. R-5709C	SHEET NO. PMP-26
APPROVED: <i>David T. Seans</i> <small>080183F28E5741E</small> DATE: 10/11/2024	
SEAL 	
DOCUMENT NOT CONSIDERED FINAL UNLESS ALL SIGNATURES COMPLETED	

NAD 83/2011

LOCATE STOP BARS AND SYMBOLS AT RAILROAD GATES PER RDWY STD. 1205.11

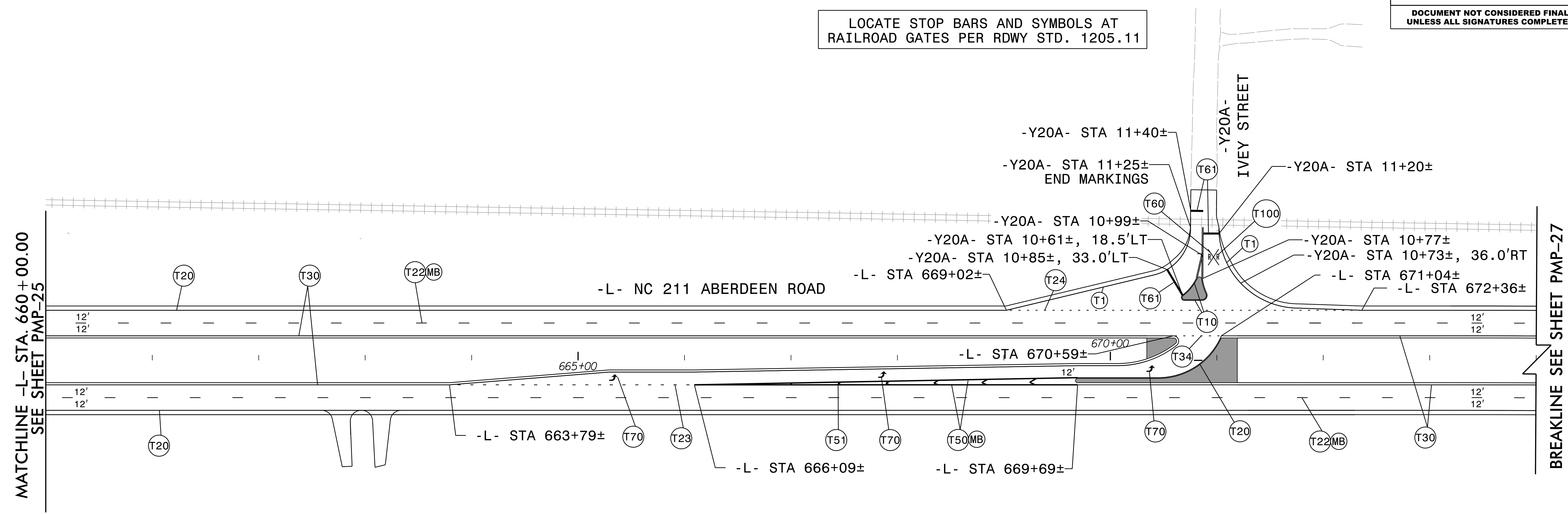

MATCHLINE -L- STA. 660+00.00
SEE SHEET PMP-25

BREAKLINE SEE SHEET PMP-27

8/29/2024
R5709C_NC211_PMP_PSH_26.dgn

RK&K
 P: (919) 878-9560
 8601 Six Forks Road, Forum 1, Suite 700
 Raleigh, North Carolina 27615-3960
 NC License No. F-0112
 Engineers | Construction Managers | Planners | Scientists
 www.rkk.com
 Responsive People | Creative Solutions

PAVEMENT MARKING DETAIL

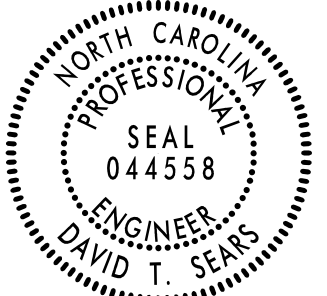
PROJECT REFERENCE NO. R - 5709C	SHEET NO. PMP - 27
APPROVED: <i>David T. Sears</i> 080183F28E5741E 10/11/2024	
DATE: 10/11/2024	
SEAL	
	
DOCUMENT NOT CONSIDERED FINAL UNLESS ALL SIGNATURES COMPLETED	

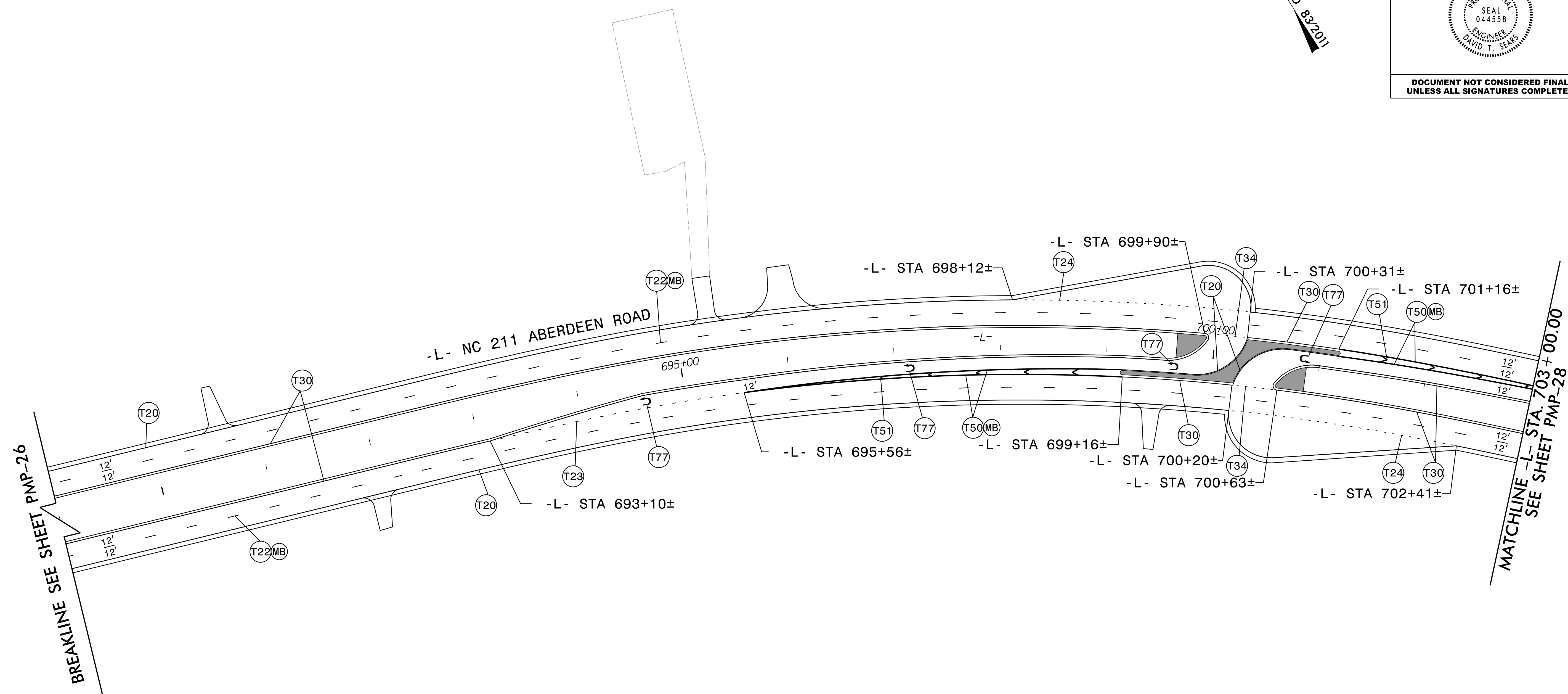
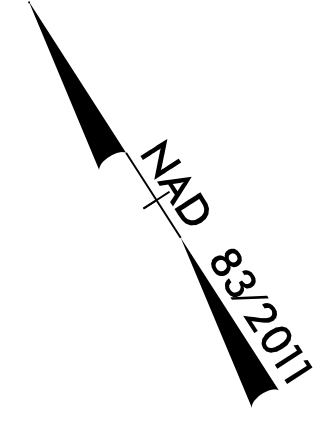

8/29/2024
R5709C_NC211_PMP_PSH_27.dgn

RK&K
 P: (919) 878-9560
 8601 Six Forks Road, Forum 1, Suite 700
 Raleigh, North Carolina 27615-3960
 NC License No. F-0112
 Engineers | Construction Managers | Planners | Scientists
 www.rkk.com
 Responsive People | Creative Solutions

PAVEMENT MARKING DETAIL

PROJECT REFERENCE NO. R - 5709C	SHEET NO. PMP - 28
APPROVED: <i>David T. Sears</i> <small>08183F28E5741E</small> DATE: 10/11/2024	
SEAL 	
DOCUMENT NOT CONSIDERED FINAL UNLESS ALL SIGNATURES COMPLETED	

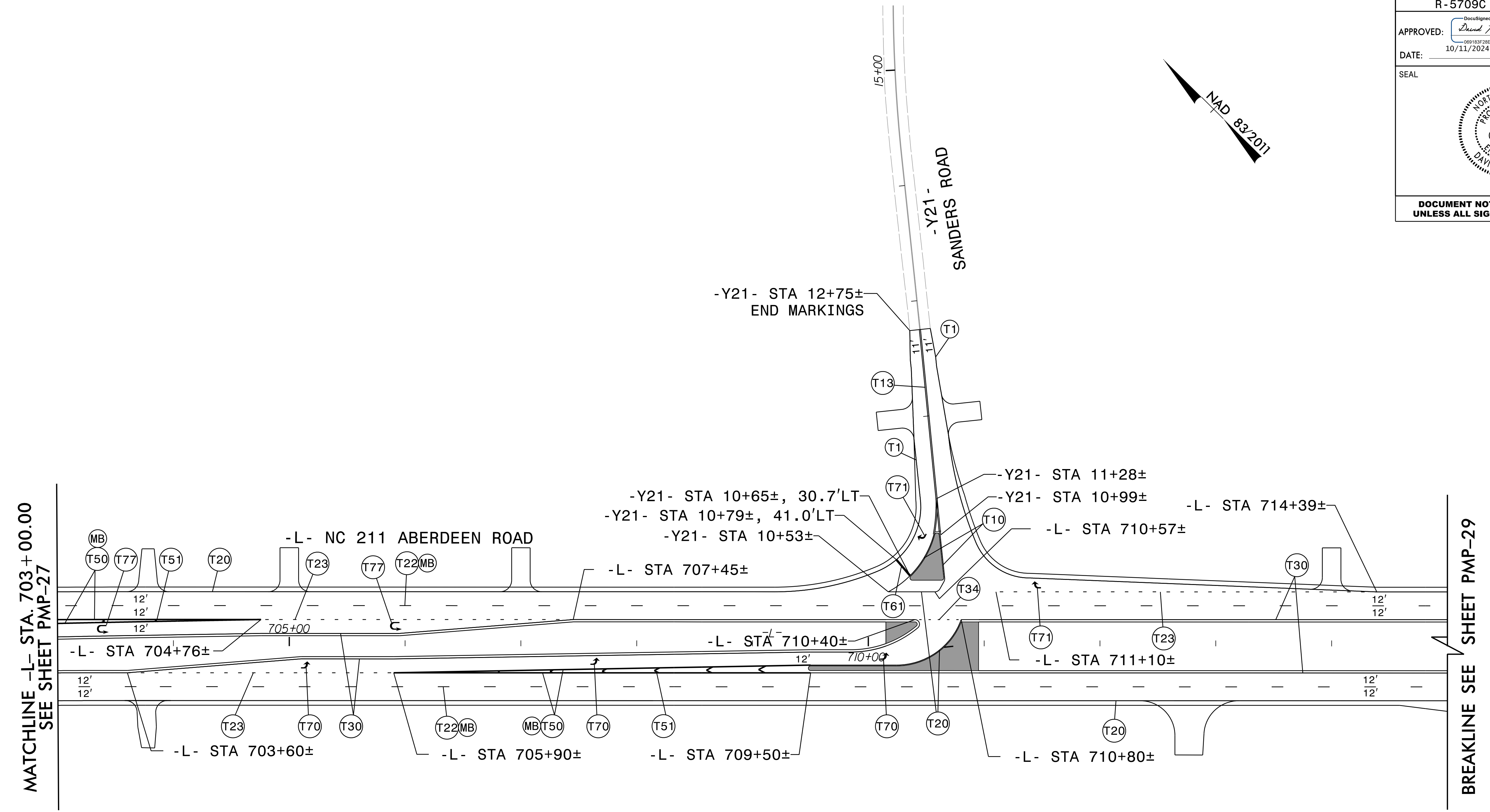
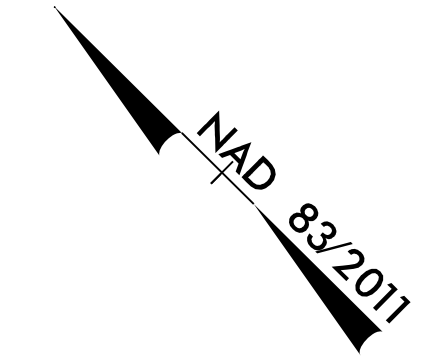

8/29/2024
 R5709C_NC211_PMP_PSH_28.dgn

RK&K
 P: (919) 878-9560
 8601 Six Forks Road, Forum 1, Suite 700
 Raleigh, North Carolina 27615-3960
 NC License No. F-0112

Engineers | Construction Managers | Planners | Scientists
 www.rkk.com

Responsive People | Creative Solutions

PAVEMENT MARKING DETAIL

PROJECT REFERENCE NO. R - 5709C	SHEET NO. PMP - 29
APPROVED: <i>David T. Sears</i> 08183F2B5741E 10/11/2024	
DATE: 10/11/2024	
SEAL	
	
DOCUMENT NOT CONSIDERED FINAL UNLESS ALL SIGNATURES COMPLETED	

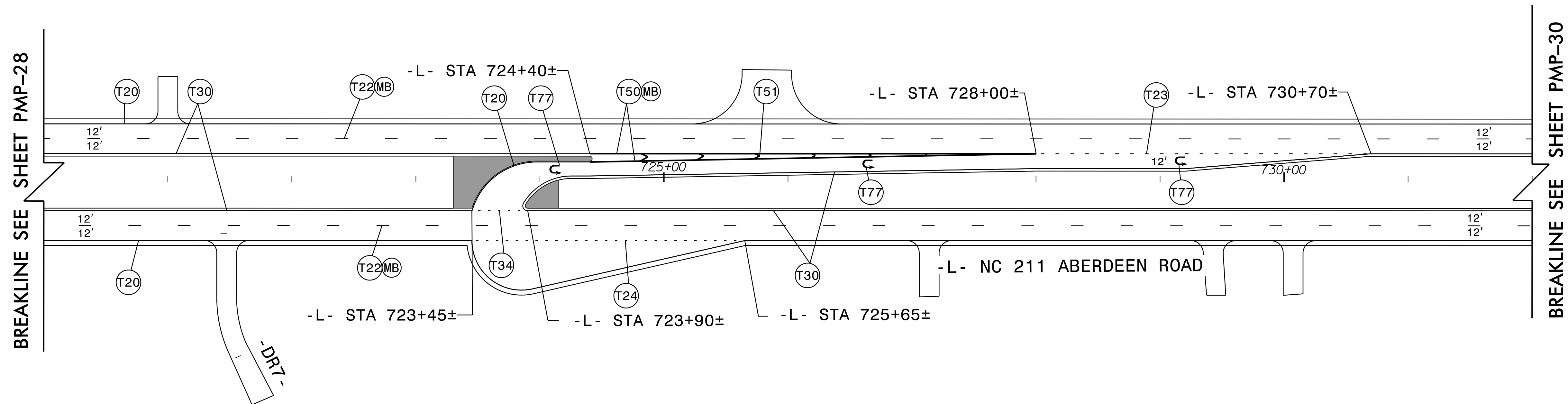

8/29/2024
R5709C_NC211_PMP_PSH_29.dgn

RK&K
 P: (919) 878-9560
 8601 Six Forks Road, Forum 1, Suite 700
 Raleigh, North Carolina 27615-3960
 NC License No. F-0112
 Engineers | Construction Managers | Planners | Scientists
 www.rkk.com
 Responsive People | Creative Solutions

PAVEMENT MARKING DETAIL

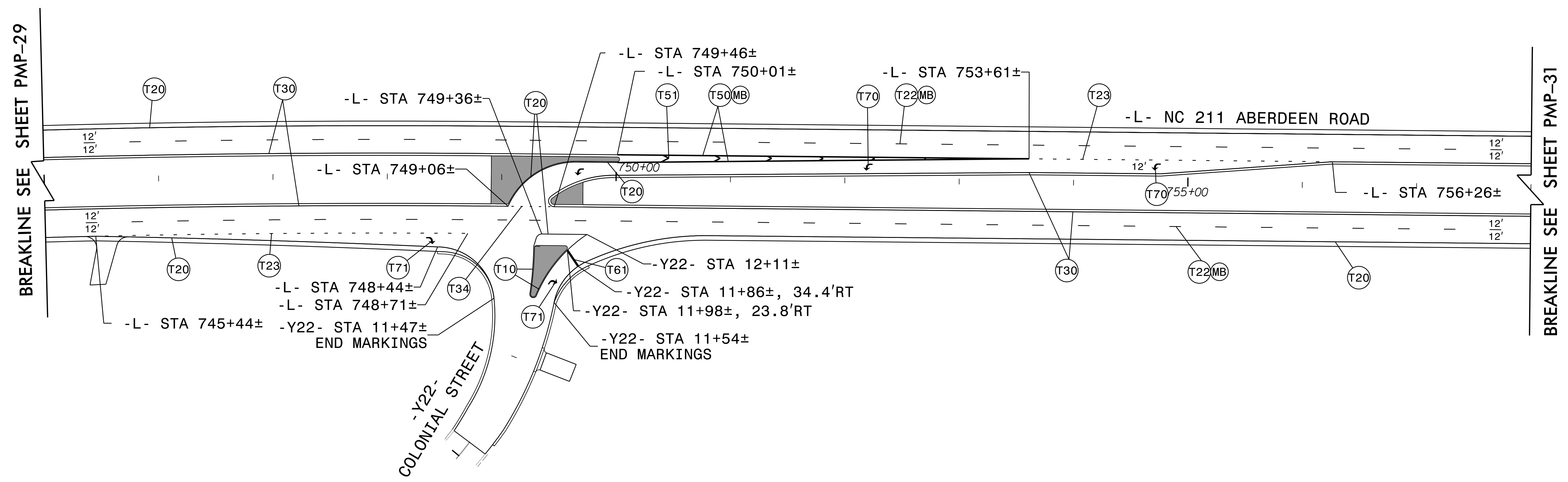
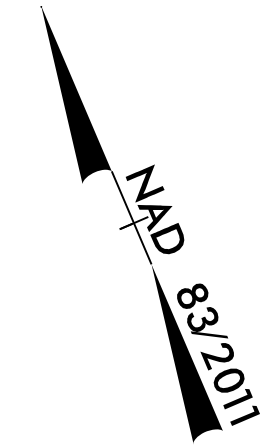

8/29/2024
R5709C_NC211_PMP_PSH_30.dgn

RK&K
 P: (919) 878-9560
 8601 Six Forks Road, Forum 1, Suite 700
 Raleigh, North Carolina 27615-3960
 NC License No. F-0112

Engineers | Construction Managers | Planners | Scientists
 www.rkk.com

Responsive People | Creative Solutions

PAVEMENT MARKING DETAIL

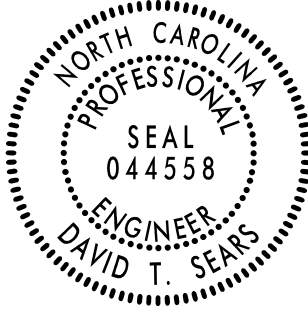
PROJECT REFERENCE NO. R - 5709C	SHEET NO. PMP - 31
APPROVED: <i>David T. Sears</i> <small>08183F2B5741E</small> DATE: 10/11/2024	
SEAL 	
DOCUMENT NOT CONSIDERED FINAL UNLESS ALL SIGNATURES COMPLETED	

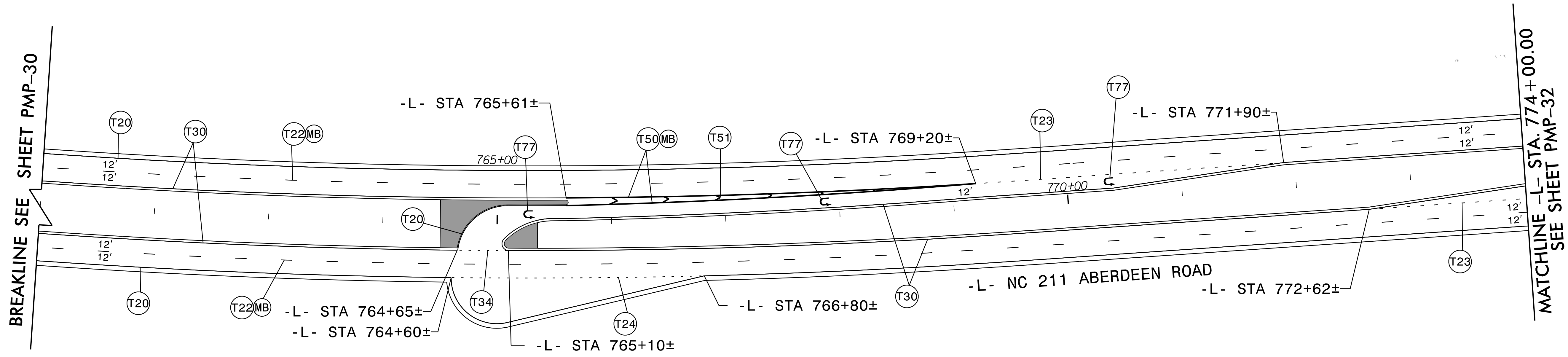
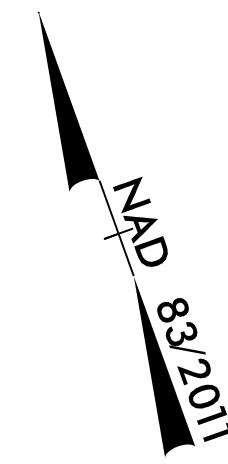

8/29/2024 R5709C_NC211_PMP_PSH_31.dgn

RK&K
 P: (919) 878-9560
 8601 Six Forks Road, Forum 1, Suite 700
 Raleigh, North Carolina 27615-3960
 NC License No. F-0112

Engineers | Construction Managers | Planners | Scientists
 www.rkk.com

Responsive People | Creative Solutions

PAVEMENT MARKING DETAIL

PROJECT REFERENCE NO. R - 5709C	SHEET NO. PMP - 32
APPROVED: <i>David T. Seans</i> 06183F28E5741E 10/11/2024	
DATE: 10/11/2024	
SEAL	
	
DOCUMENT NOT CONSIDERED FINAL UNLESS ALL SIGNATURES COMPLETED	

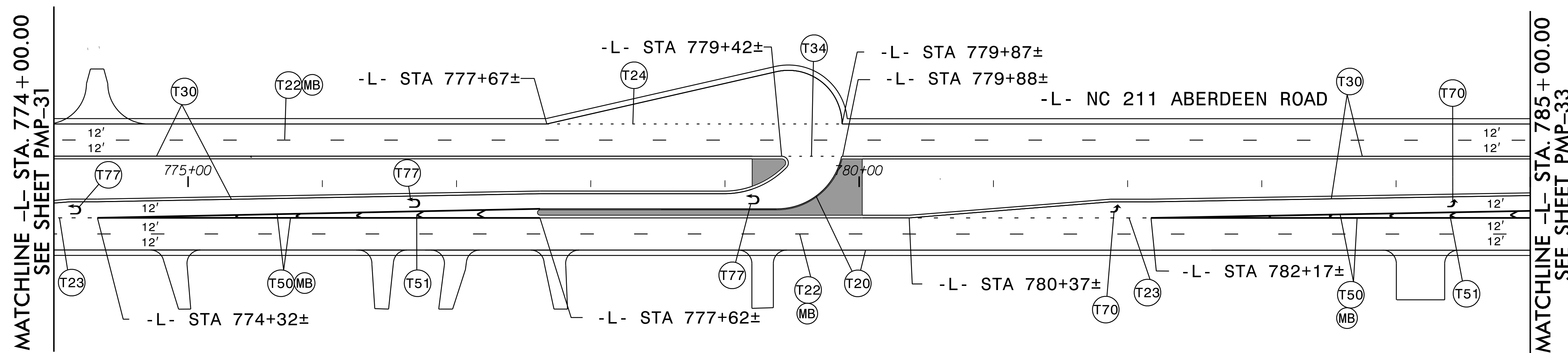
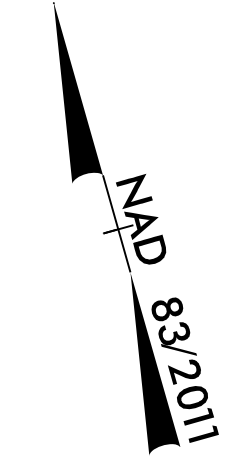

8/29/2024
R5709C_NC211_PMP_PSH_32.dgn

RK&K
 P: (919) 878-9560
 8601 Six Forks Road, Forum 1, Suite 700
 Raleigh, North Carolina 27615-3960
 NC License No. F-0112

Engineers | Construction Managers | Planners | Scientists
 www.rkk.com

Responsive People | Creative Solutions

PAVEMENT MARKING DETAIL

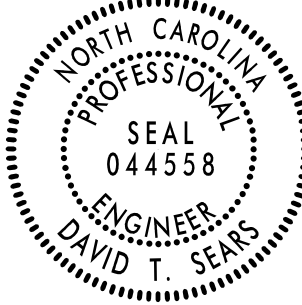
PROJECT REFERENCE NO. R-5709C	SHEET NO. PMP-33
APPROVED: <i>David T. Sears</i> 08183F2B5741E 10/11/2024	
DATE: 10/11/2024	
SEAL 	
DOCUMENT NOT CONSIDERED FINAL UNLESS ALL SIGNATURES COMPLETED	

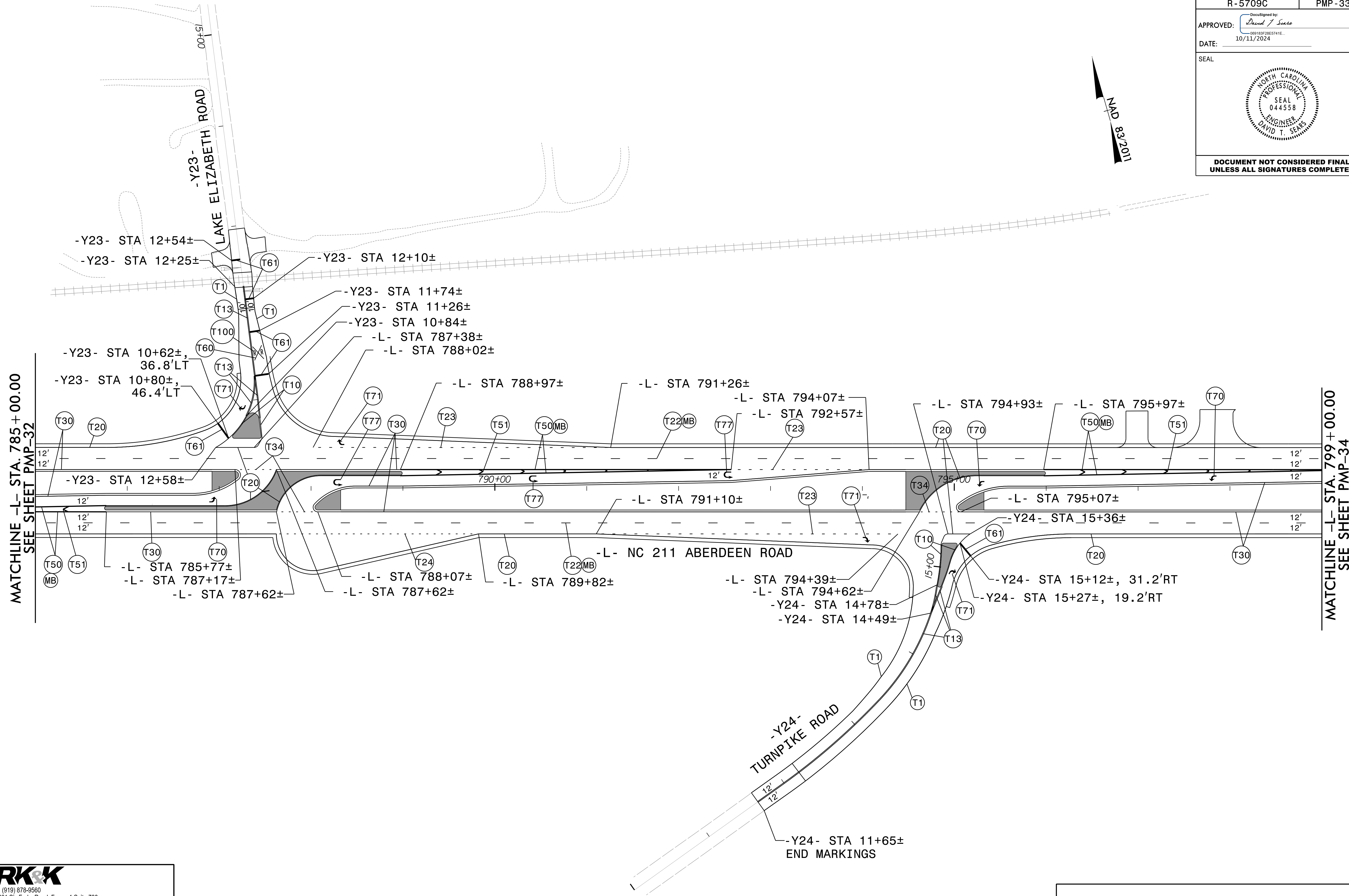
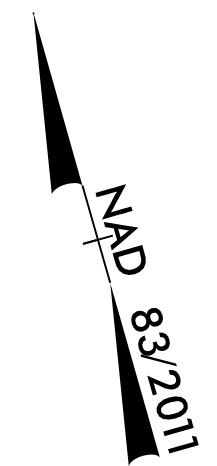

MATCHLINE -L- STA. 785+00.00
SEE SHEET PMP-32

MATCHLINE -L- STA. 799+00.00
SEE SHEET PMP-34

8/29/2024
R5709C_NC211_PMP_PSH_33.dgn

RK&K
P: (919) 878-9560
8601 Six Forks Road, Forum 1, Suite 700
Raleigh, North Carolina 27615-3960
NC License No. F-0112

Engineers | Construction Managers | Planners | Scientists
www.rkk.com

Responsive People | Creative Solutions

PAVEMENT MARKING DETAIL

PROJECT REFERENCE NO. R - 5709C	SHEET NO. PMP - 34
APPROVED: <i>David T. Seans</i> 08183F28E5741E 10/11/2024	
DATE: 10/11/2024	
SEAL	
	
DOCUMENT NOT CONSIDERED FINAL UNLESS ALL SIGNATURES COMPLETED	

NAD 83/2011

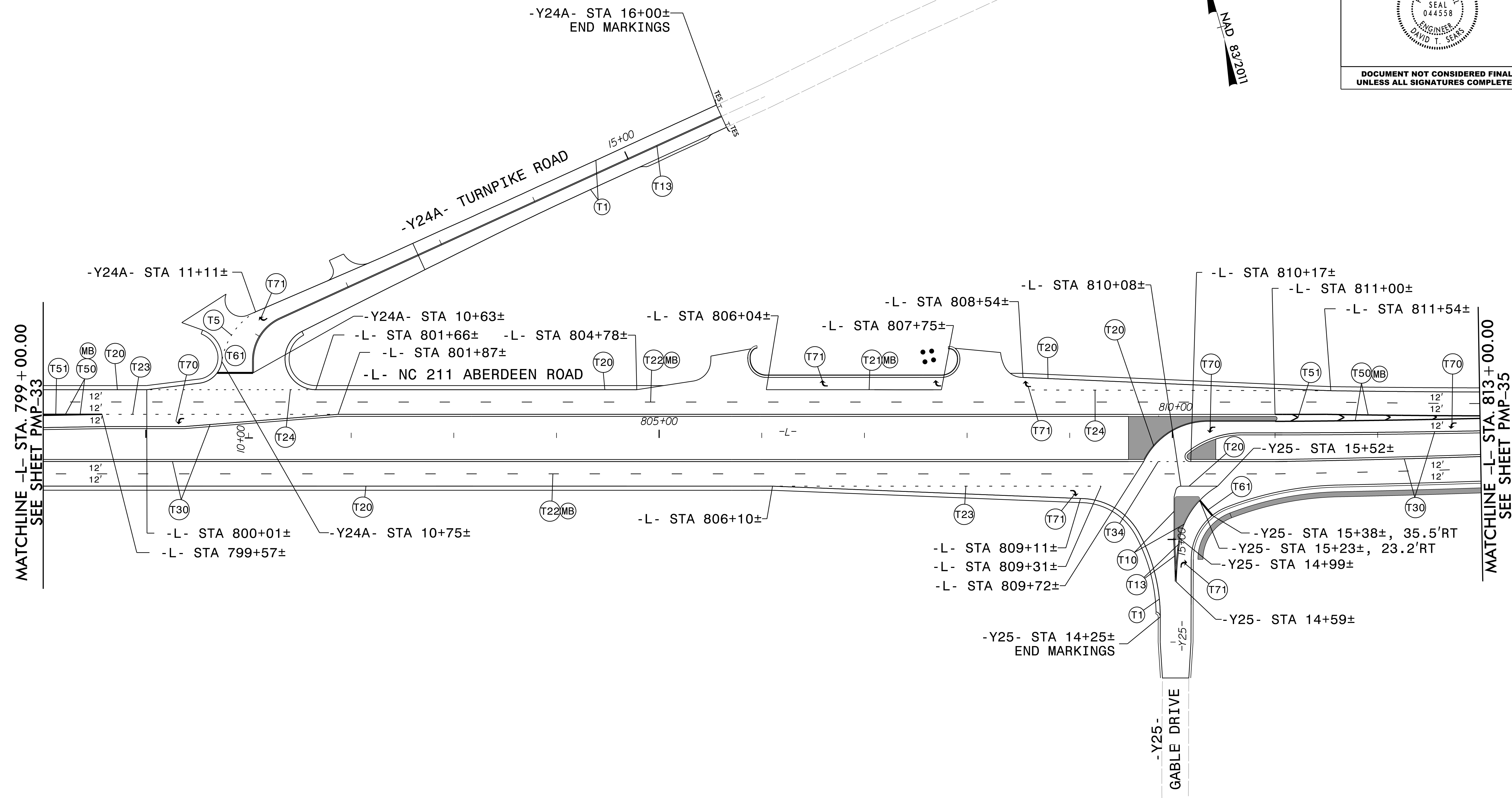

8/29/2024
R5709C_NC211_PMP_PSH_34.dgn

RK&K
 P: (919) 878-9560
 8601 Six Forks Road, Forum 1, Suite 700
 Raleigh, North Carolina 27615-3960
 NC License No. F-9112

Engineers | Construction Managers | Planners | Scientists
 www.rkk.com

Responsive People | Creative Solutions

PAVEMENT MARKING DETAIL

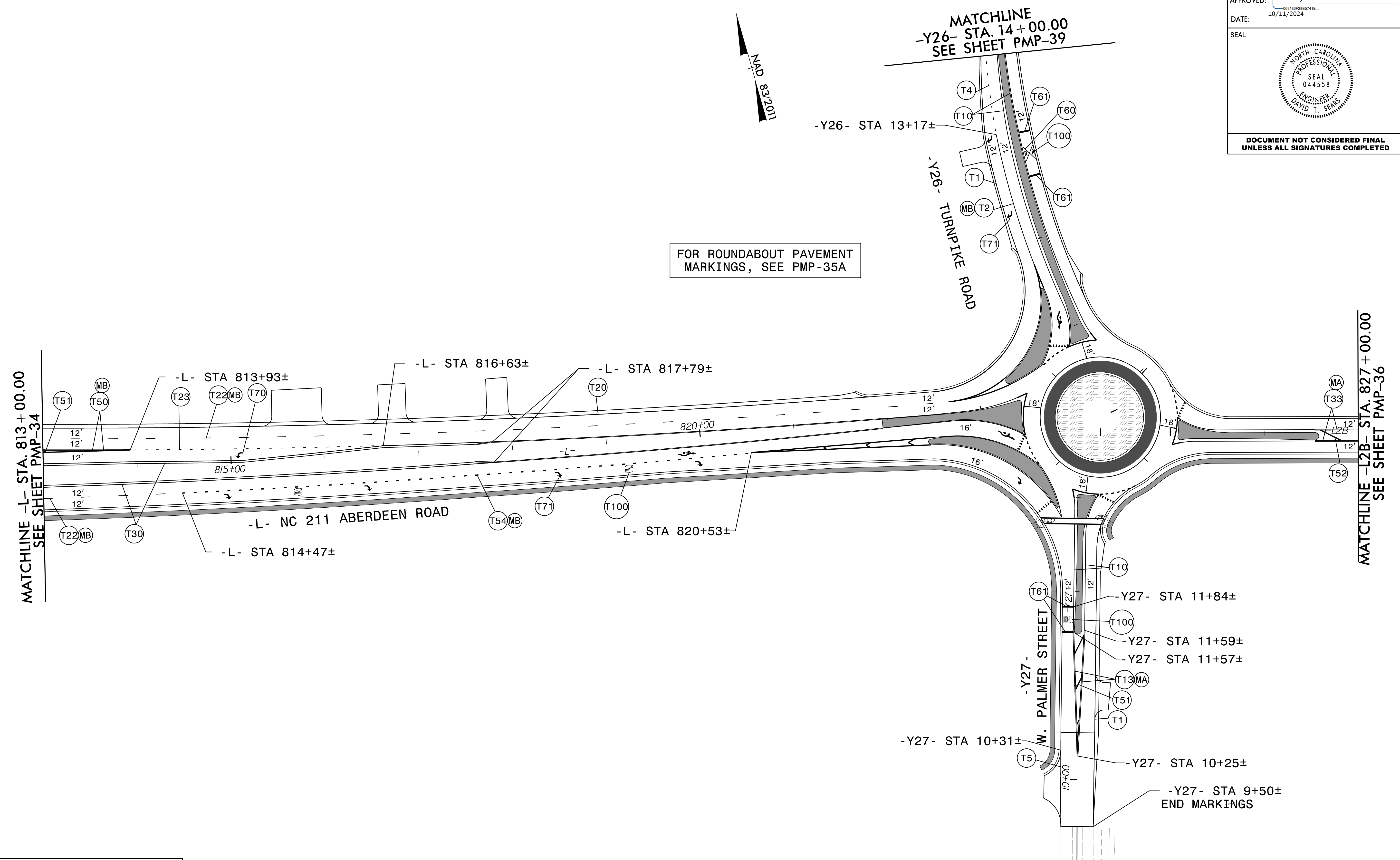
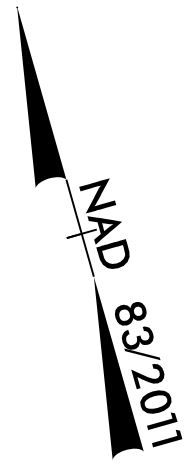

FOR ROUNDABOUT PAVEMENT MARKINGS, SEE PMP-35A

MATCHLINE -L- STA. 813+00.00
SEE SHEET PMP-34

MATCHLINE -L2B- STA. 827+00.00
SEE SHEET PMP-36

PAVEMENT MARKING DETAIL

8/29/2024
R5709C_NC211_PMP_PSH_35.dgn



P: (919) 878-9560
8601 Six Forks Road, Forum 1, Suite 700
Raleigh, North Carolina 27615-3960
NC License No. F-0112

Engineers | Construction Managers | Planners | Scientists
www.rkk.com

Responsive People | Creative Solutions

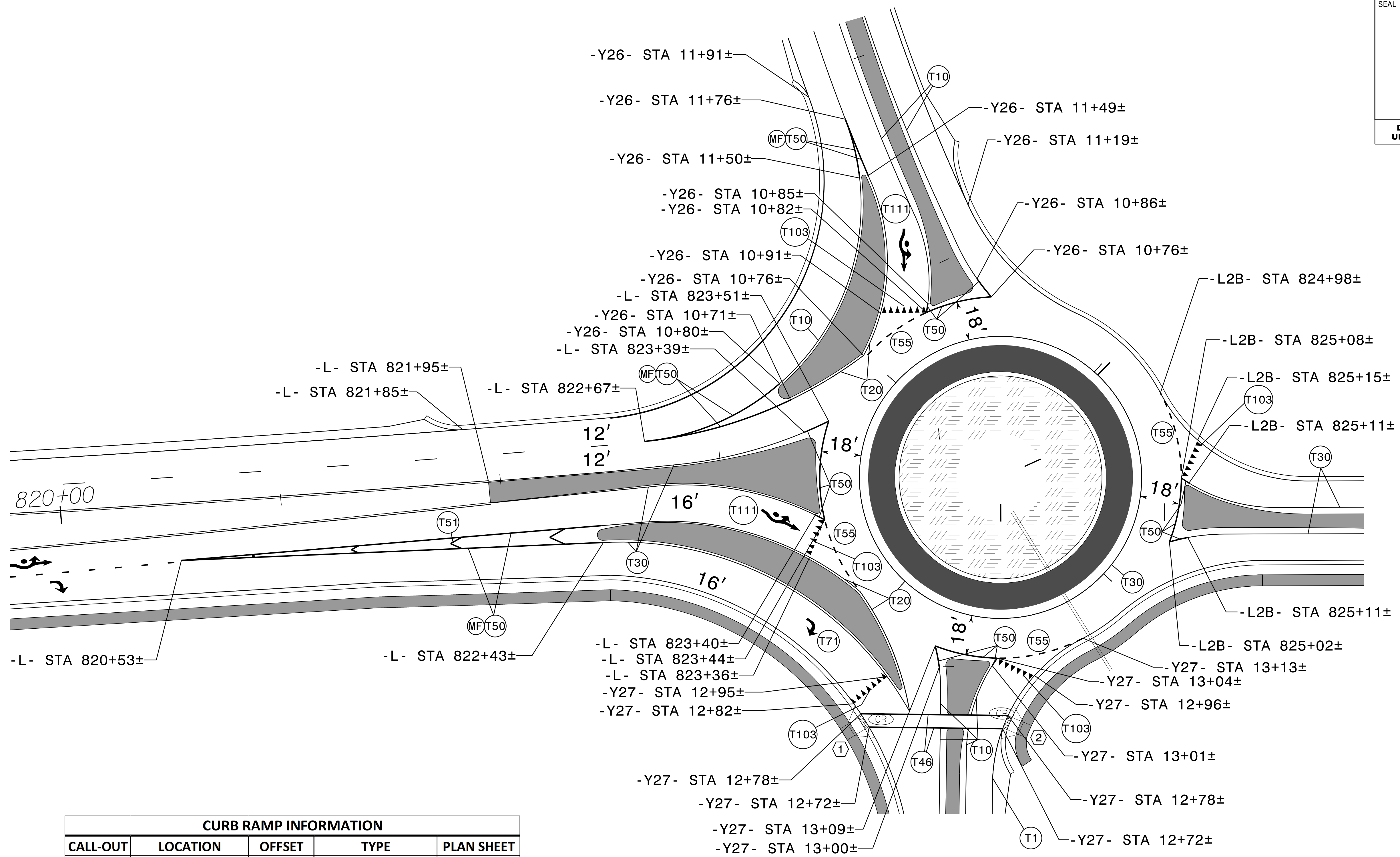

CURB RAMP INFORMATION				
CALL-OUT	LOCATION	OFFSET	TYPE	PLAN SHEET
1	-Y27-STA 12+75	40' LT	STANDARD	35A
2	-Y27-STA 12+75	23' RT	STANDARD	35A

PROJECT REFERENCE NO. R - 5709C	SHEET NO. PMP - 36
APPROVED: <i>David T. Sears</i> 000183F2B5741E 10/11/2024	
DATE: 10/11/2024	
SEAL	
	
DOCUMENT NOT CONSIDERED FINAL UNLESS ALL SIGNATURES COMPLETED	

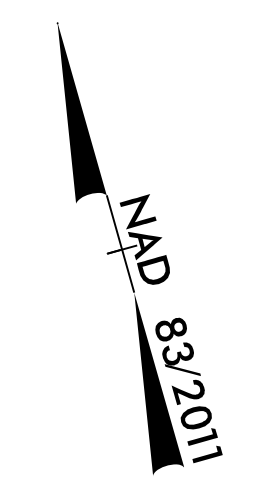

MATCHLINE -L2B- STA. 827 + 00.00
SEE SHEET PMP-35

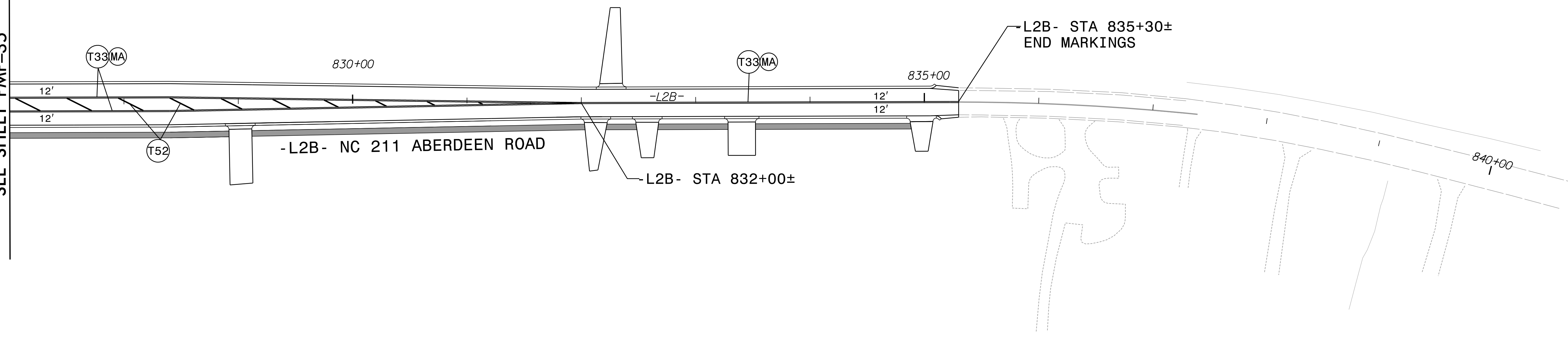

8/29/2024
R5709C_NC211_PMP_PSH_36.dgn

RK&K
P: (919) 878-9560
8601 Six Forks Road, Forum 1, Suite 700
Raleigh, North Carolina 27615-3960
NC License No. F-0112

Engineers | Construction Managers | Planners | Scientists
www.rkk.com

Responsive People | Creative Solutions

PAVEMENT MARKING DETAIL

PROJECT REFERENCE NO. R - 5709C	SHEET NO. PMP - 37
APPROVED: <i>David T. Sears</i> <small>000103F28E5741E</small> DATE: 10/11/2024	
SEAL 	
DOCUMENT NOT CONSIDERED FINAL UNLESS ALL SIGNATURES COMPLETED	

NAD 83/2011

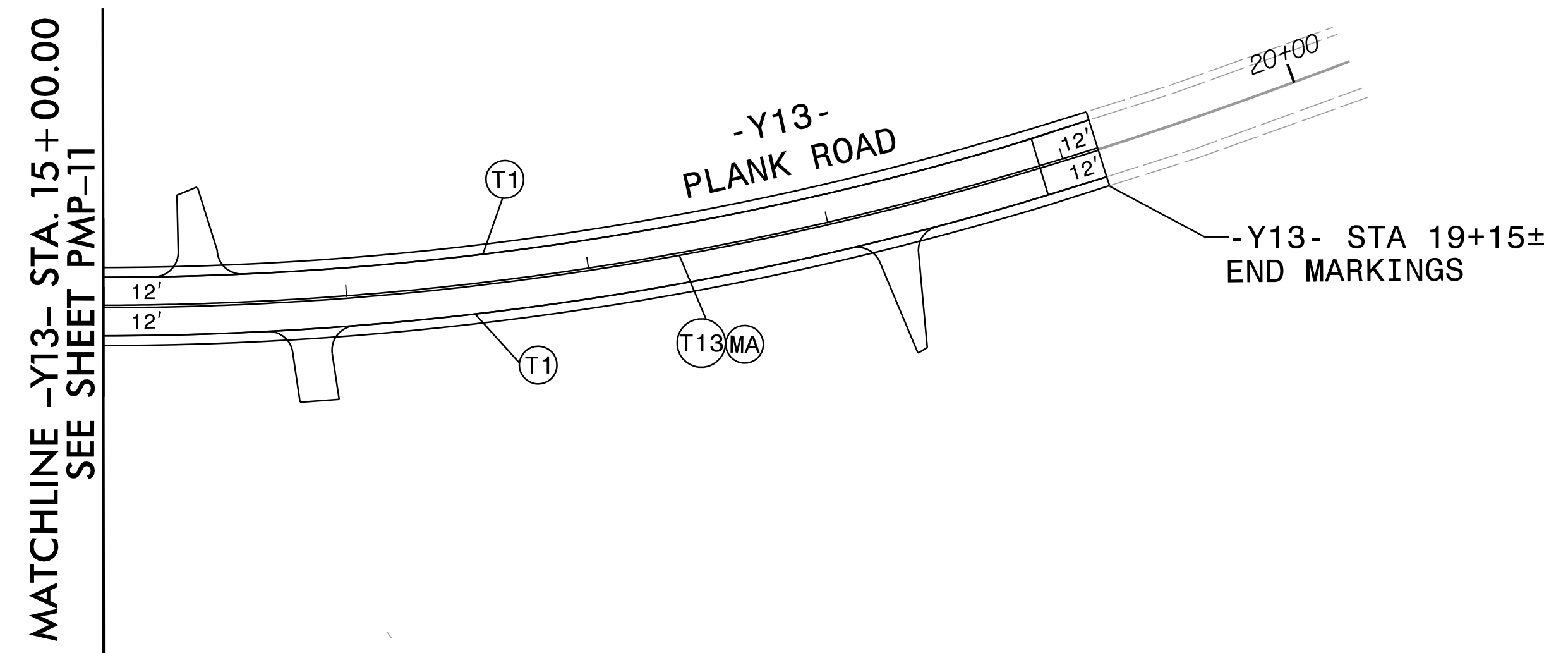

8/29/2024
R5709C_NC211_PMP_PSH_37.dgn

RK&K
 P: (919) 878-9560
 8601 Six Forks Road, Forum 1, Suite 700
 Raleigh, North Carolina 27615-3960
 NC License No. F-0112

Engineers | Construction Managers | Planners | Scientists
 www.rkk.com

Responsive People | Creative Solutions

PAVEMENT MARKING DETAIL

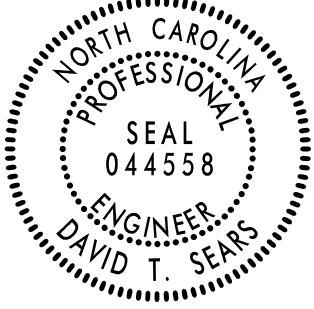
PROJECT REFERENCE NO. R - 5709C	SHEET NO. PMP - 38
APPROVED: <i>David T. Sears</i> <small>080183F2B5741E</small>	
DATE: 10/11/2024	
SEAL	
	
DOCUMENT NOT CONSIDERED FINAL UNLESS ALL SIGNATURES COMPLETED	

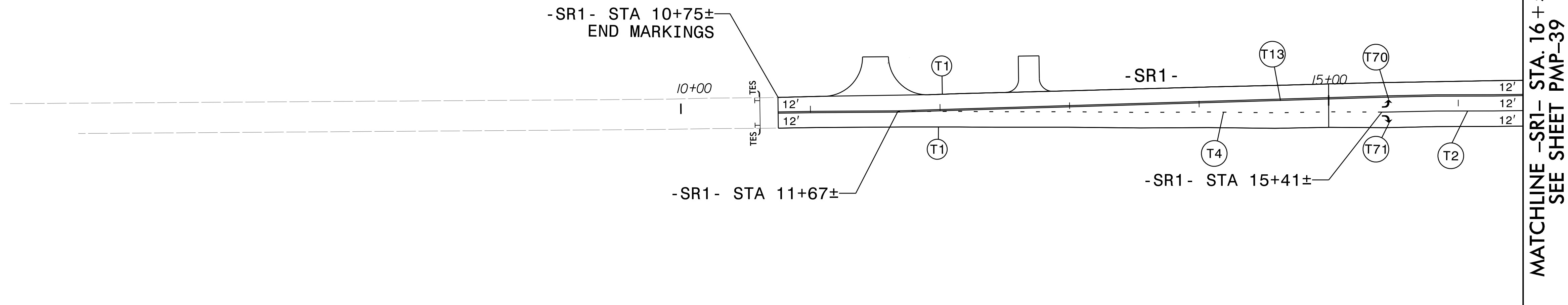

MATCHLINE -SR1- STA. 16 + 50.00
SEE SHEET PMP-39

8/29/2024
R5709C_NC211_PMP_PSH_38.dgn

RK&K
P: (919) 878-9560
8601 Six Forks Road, Forum 1, Suite 700
Raleigh, North Carolina 27615-3960
NC License No. F-0112

Engineers | Construction Managers | Planners | Scientists
www.rkk.com

Responsive People | Creative Solutions

PAVEMENT MARKING DETAIL

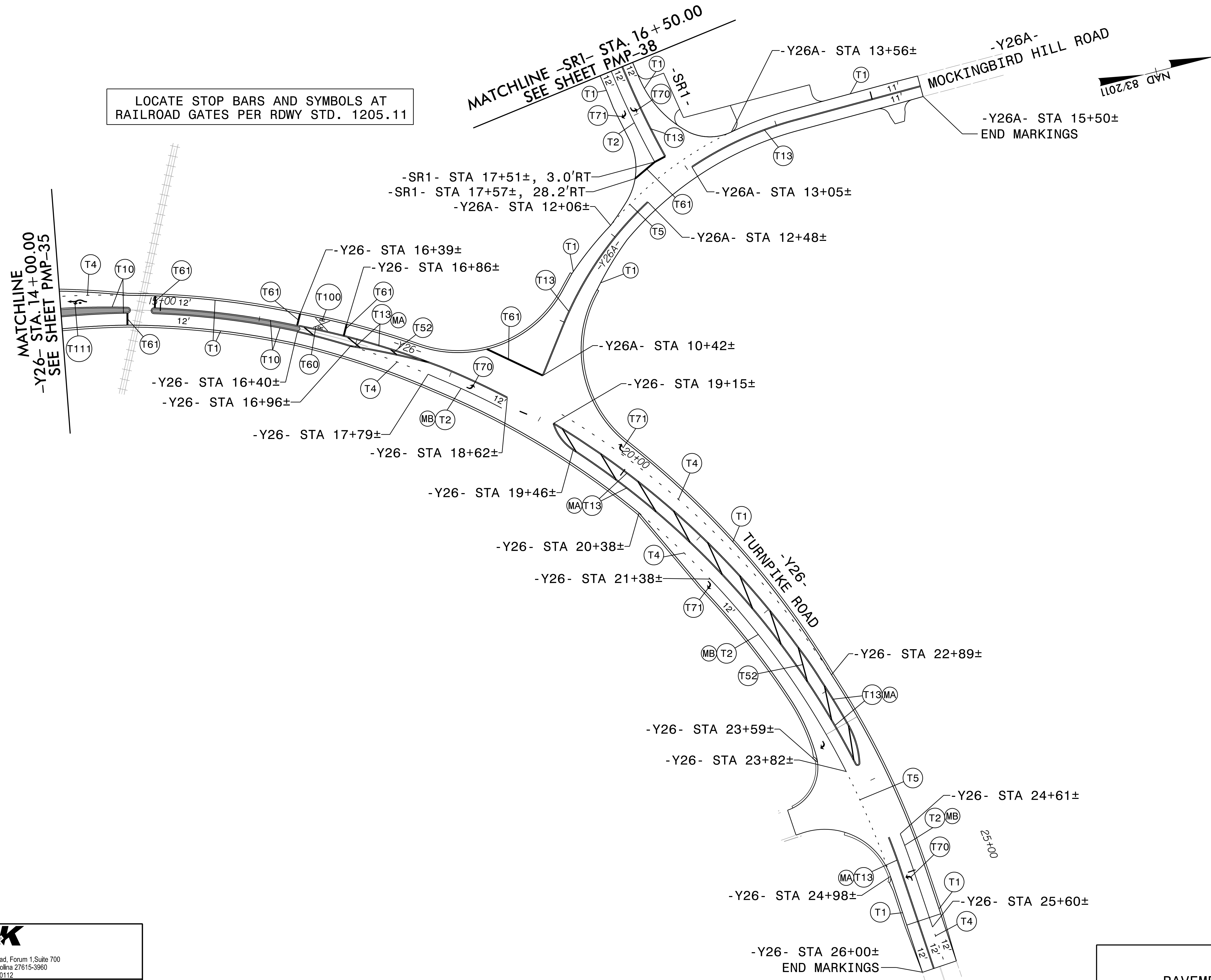

PAVEMENT MARKING DETAIL