

SEE TMP-28A FOR SECTION VIEW
 SEE TMP-1C FOR -Y11C- SANDHILLS DR OFFSITE DETOUR.
 -Y11C- SR 1221 SHALL NOT BE CLOSED CONCURRENTLY WITH -Y12A- SR 1221
 * SET BACK STOP BAR 10' FROM NC 211.
 ERECT STOP SIGN (R1-1 36"X36") ON -Y11C- SANDHILLS DR TO OPENING.

APPROVED: Kevin W. Bisby
 DATE: 10/15/2024
 SEAL

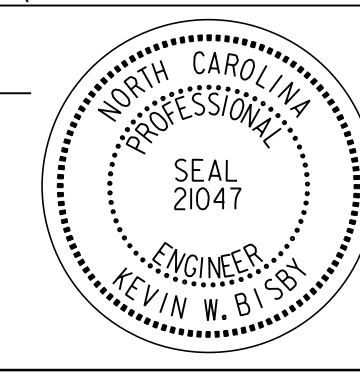
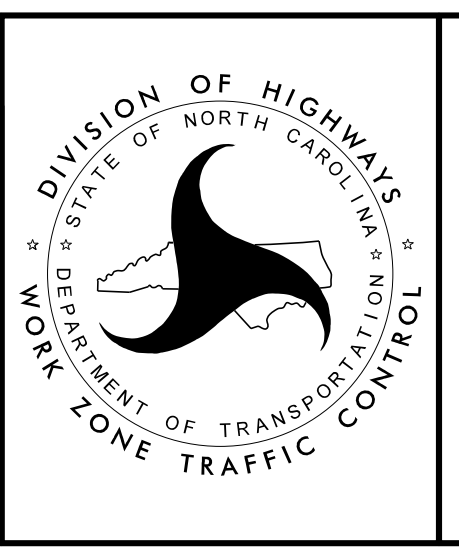

PHASE I
 STEP 3 DETAILS

PROJ. REFERENCE NO.	SHEET NO.
R-5709C	TMP-28A

RKK
 P: (919) 878-8560
 8601 Six Forks Road, Forum 1, Suite 700
 Raleigh, North Carolina 27615-3960
 NC License No. F-0112
 Engineers | Construction Managers | Planners | Scientists
 www.rkk.com
 Responsive People | Creative Solutions

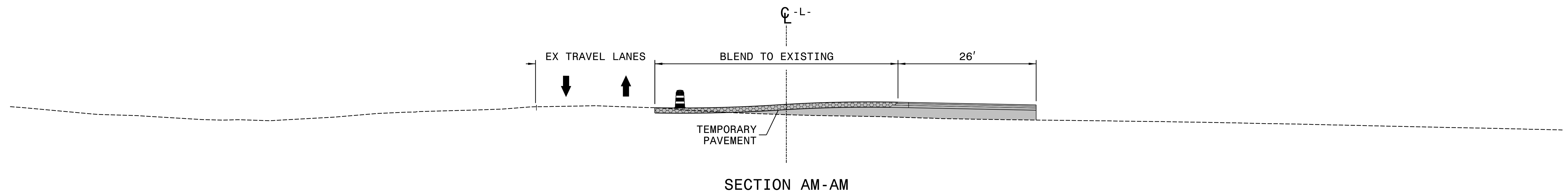

8/28/2024
 RST05_TMP-psht28A.dgn
 RStebby

APPROVED: <u>Kevin W. Bisby</u> DATE: 10/15/2024 SEAL			<p align="center">PHASE I STEP 3 DETAILS</p>
<p align="center">DOCUMENT NOT CONSIDERED FINAL UNLESS ALL SIGNATURES COMPLETED</p>			

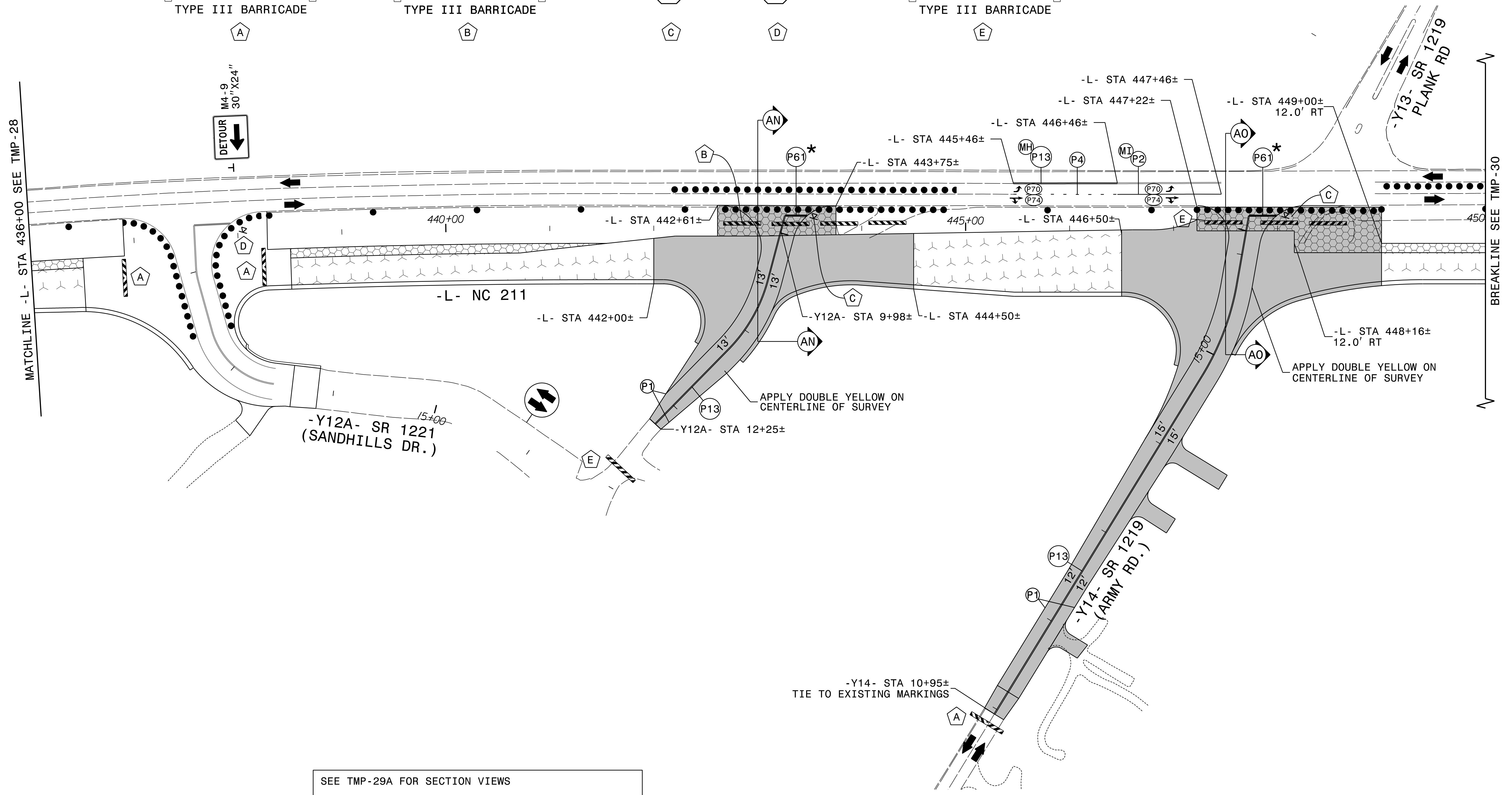
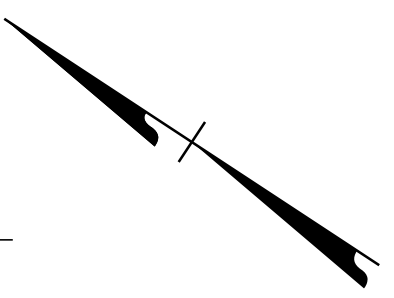
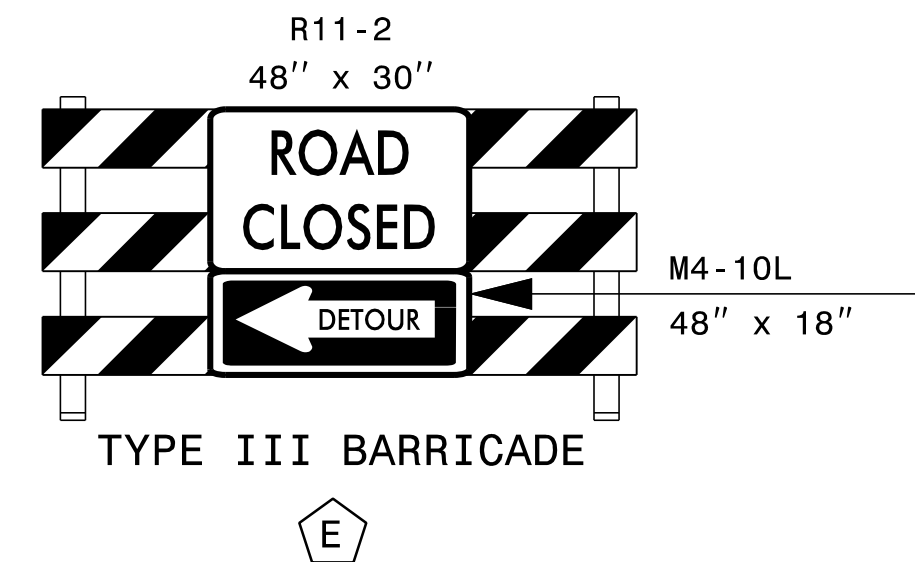
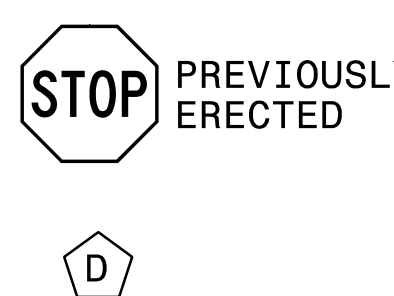
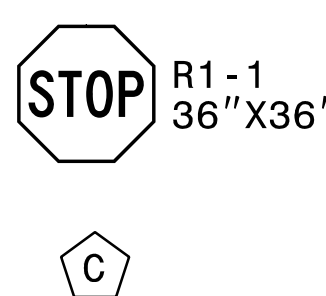
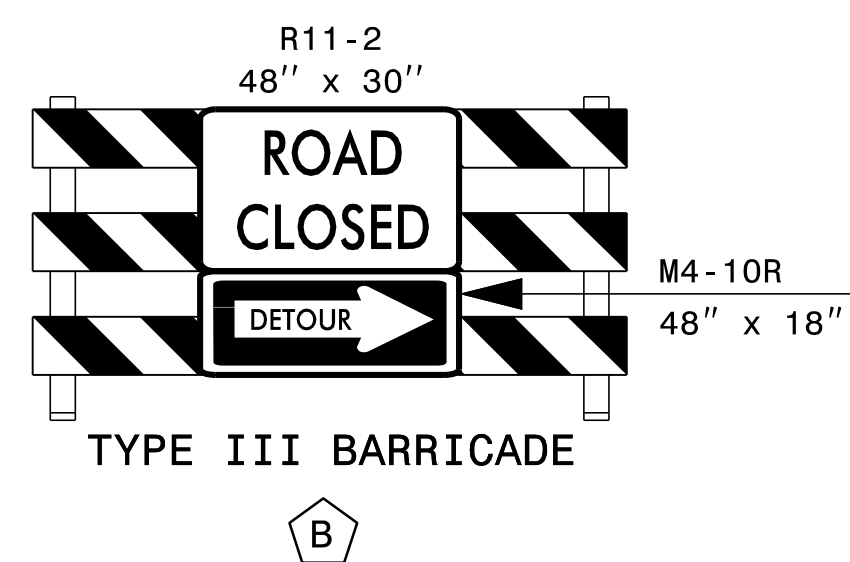
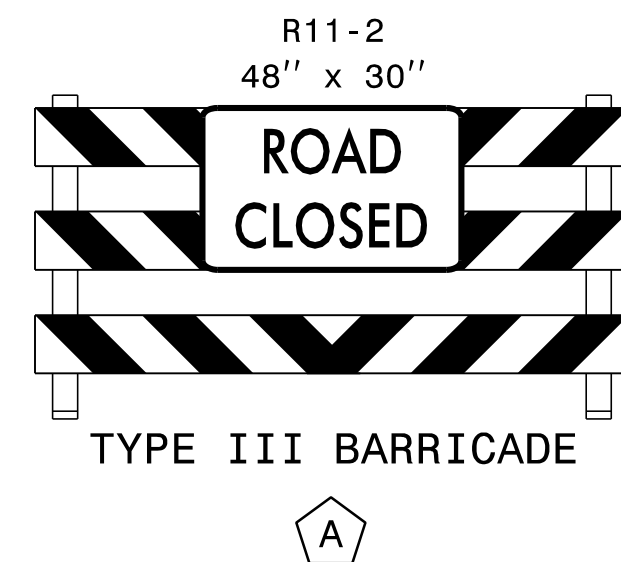

SEE TMP-29A FOR SECTION VIEWS
 -Y12A- SR 1221 SHALL NOT BE CLOSED CONCURRENTLY WITH -Y11C- SR 1221
 SEE TMP-1D FOR -Y14- ARMY RD OFFSITE DETOUR.
 COMPLETE CONSTRUCTION OF -Y14- AND PLACE TRAFFIC ON SAME PRIOR TO BEGINNING CONSTRUCTION OF -Y15-
 * SET BACK STOP BAR 10' FROM NC 211.
 ERECT STOP SIGN (R1-1 36"X36") ON SANDHILLS DR AND ARMY RD TO OPENING.

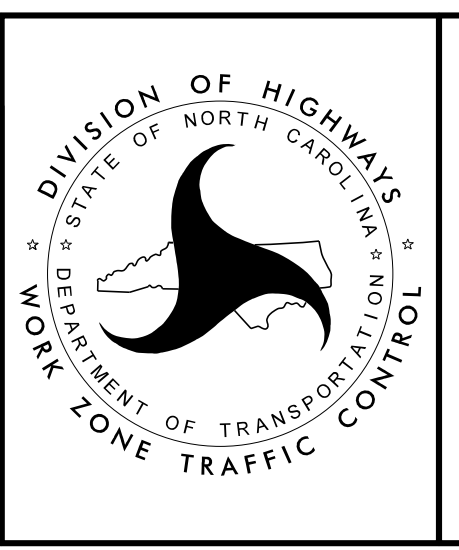

APPROVED: *Kevin W. Bisby*
 DATE: 10/15/2024
 SEAL
 NORTH CAROLINA PROFESSIONAL ENGINEER
 SEAL 21047
 KEVIN W. BISBY

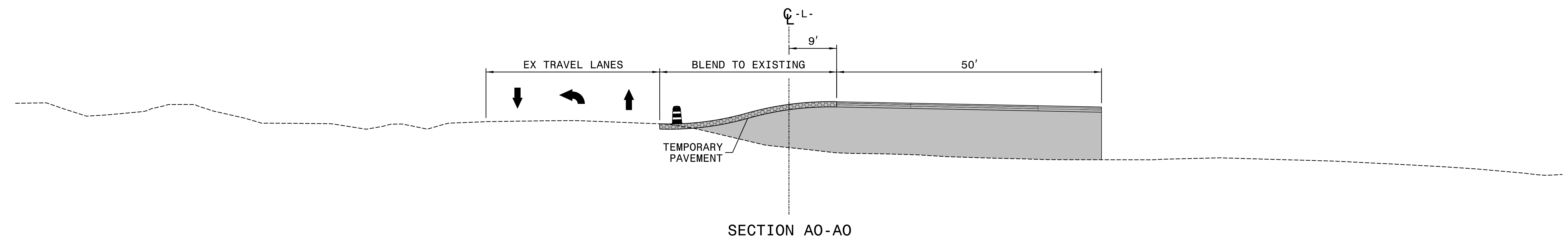
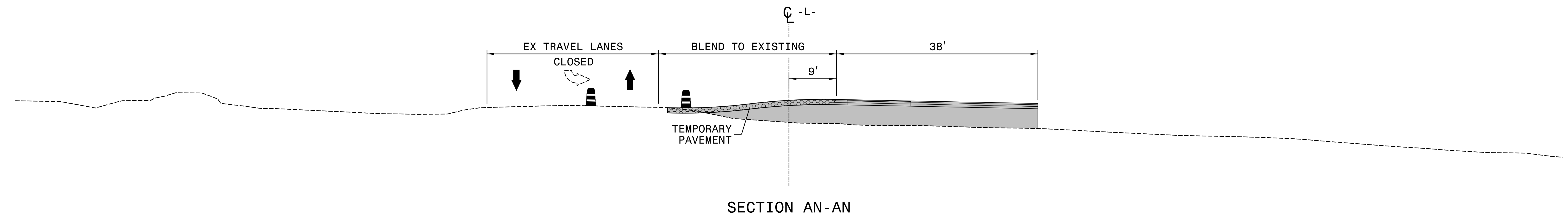

PHASE I
 STEP 3 DETAILS

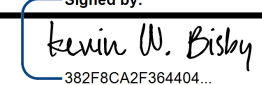

8/28/2024
 RST05_TMP_psh29A.dgn
 R015by

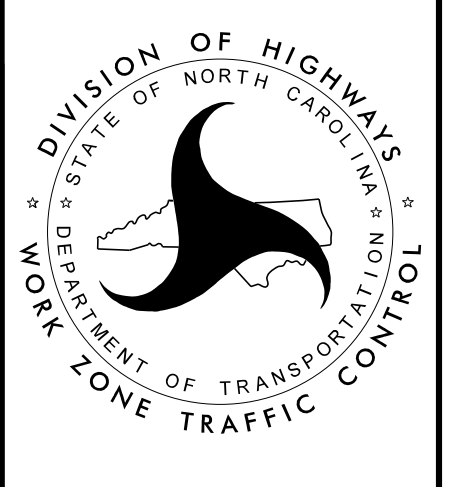
APPROVED:  DATE: 10/15/2024 SEAL 		<p>PHASE I STEP 3 DETAILS</p>
<p>DOCUMENT NOT CONSIDERED FINAL UNLESS ALL SIGNATURES COMPLETED</p>		

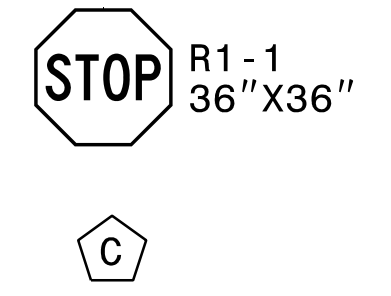
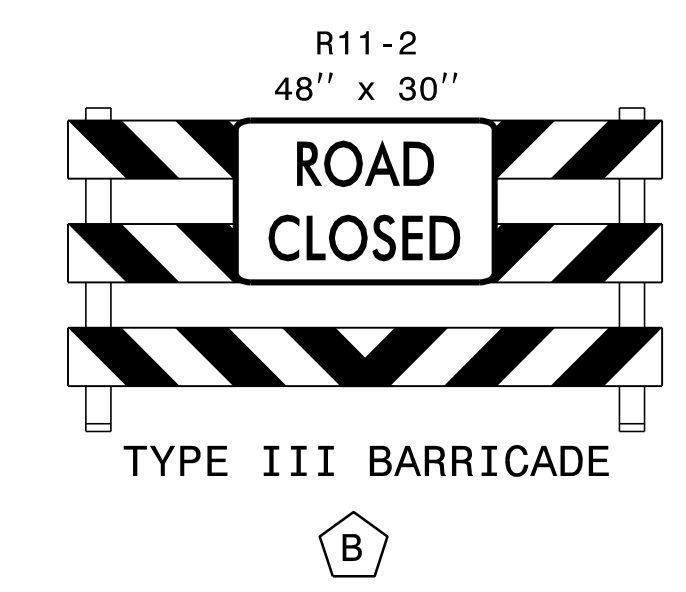
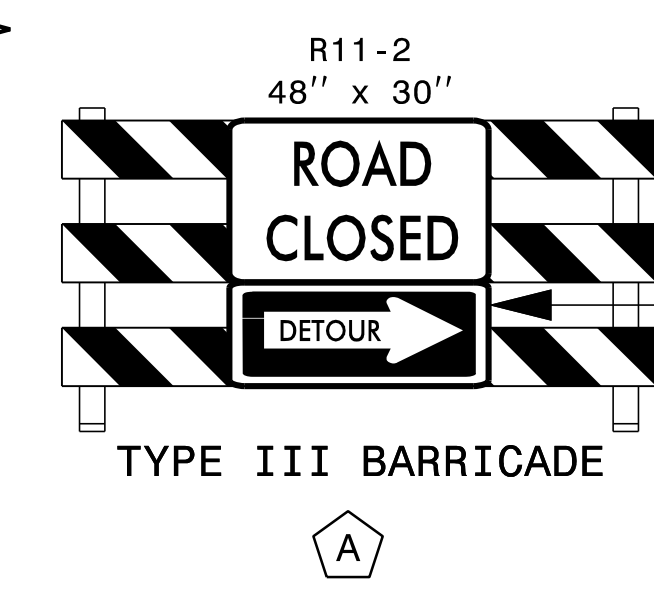
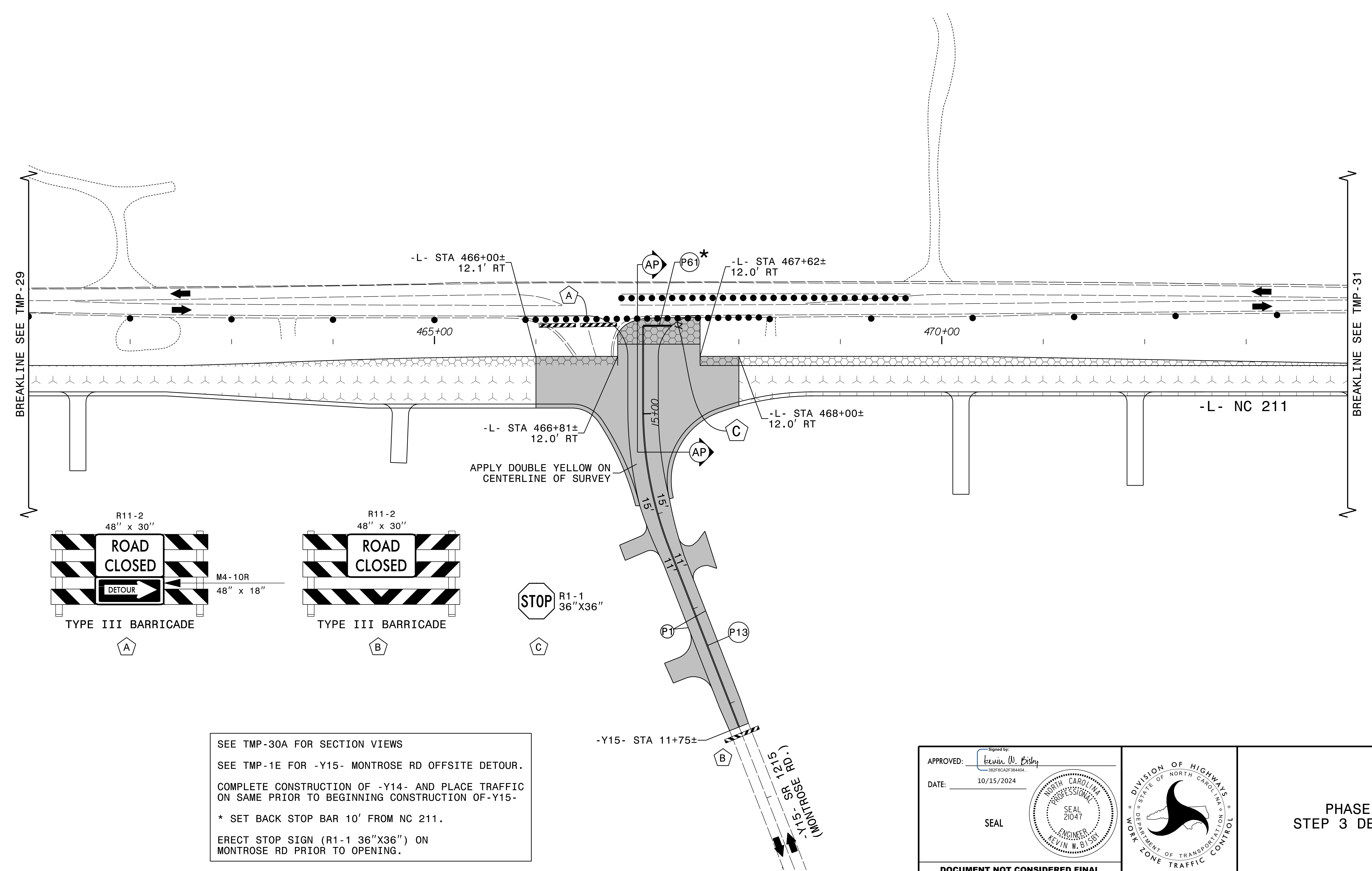
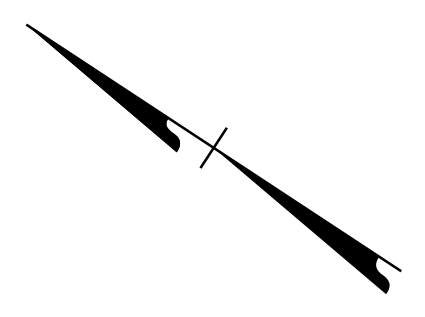

SEE TMP-30A FOR SECTION VIEWS
 SEE TMP-1E FOR -Y15- MONTROSE RD OFFSITE DETOUR.
 COMPLETE CONSTRUCTION OF -Y14- AND PLACE TRAFFIC ON SAME PRIOR TO BEGINNING CONSTRUCTION OF -Y15-
 * SET BACK STOP BAR 10' FROM NC 211.
 ERECT STOP SIGN (R1-1 36"X36") ON MONTROSE RD PRIOR TO OPENING.

APPROVED: Kevin W. Bisby
382F8CA3F364404
 DATE: 10/15/2024

SEAL

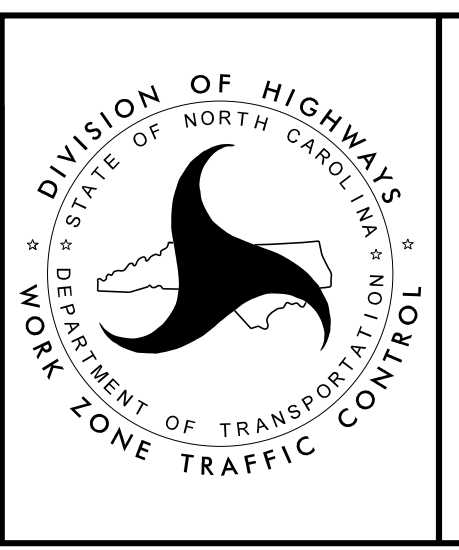

PHASE I
 STEP 3 DETAILS

8/28/2024
 RST05_TMP_psh30.dgn
 Robby

PROJ. REFERENCE NO.	SHEET NO.
R-5709C	TMP-30A

RKK
 P: (919) 878-8560
 8601 Six Forks Road, Forum 1, Suite 700
 Raleigh, North Carolina 27615-3960
 NC License No. F-0112
 Engineers | Construction Managers | Planners | Scientists
 www.rkk.com
 Responsive People | Creative Solutions

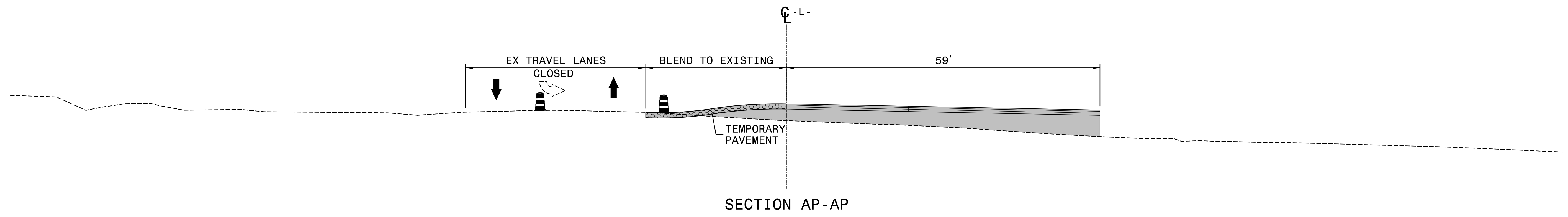

8/28/2024
 RST05_TMP_psh30A.dgn
 RStebby

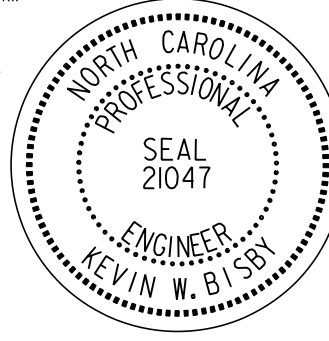
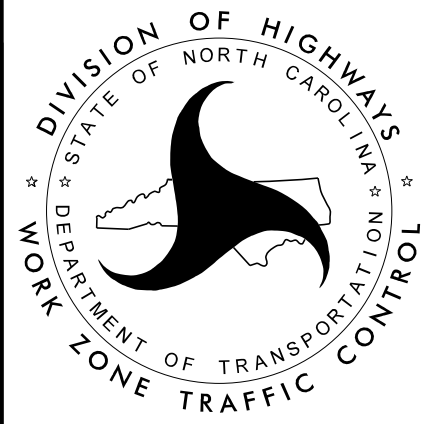
APPROVED: <i>Kevin W. Bisby</i> <small>Signed by 382F9CA2F364404</small> DATE: 10/15/2024 SEAL	 	<p>PHASE I STEP 3 DETAILS</p>
<p>DOCUMENT NOT CONSIDERED FINAL UNLESS ALL SIGNATURES COMPLETED</p>		

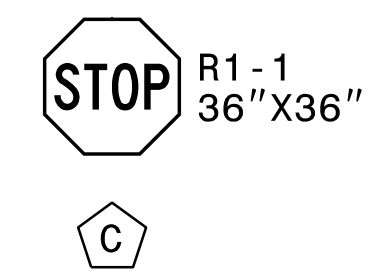
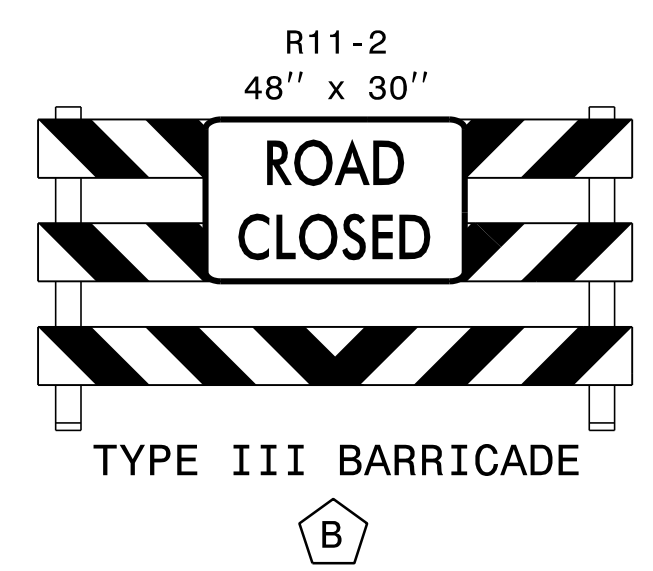
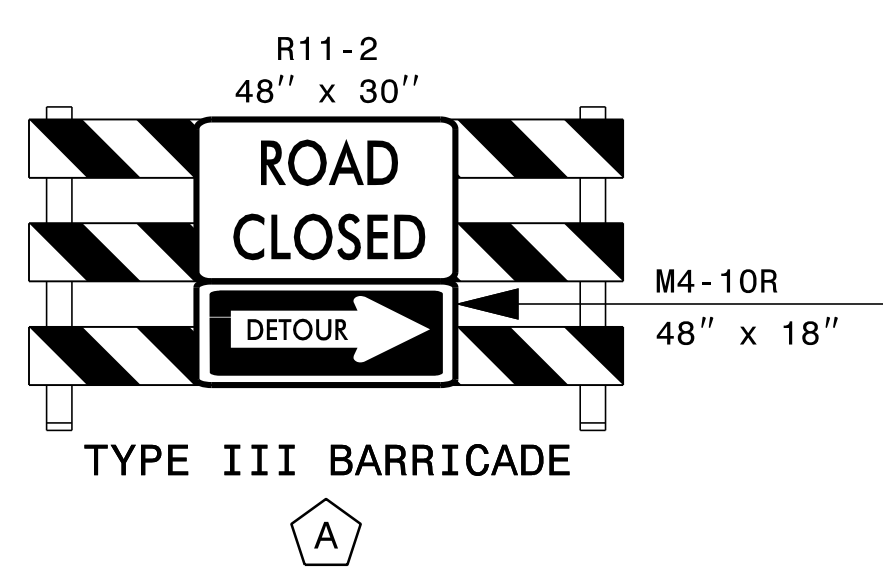
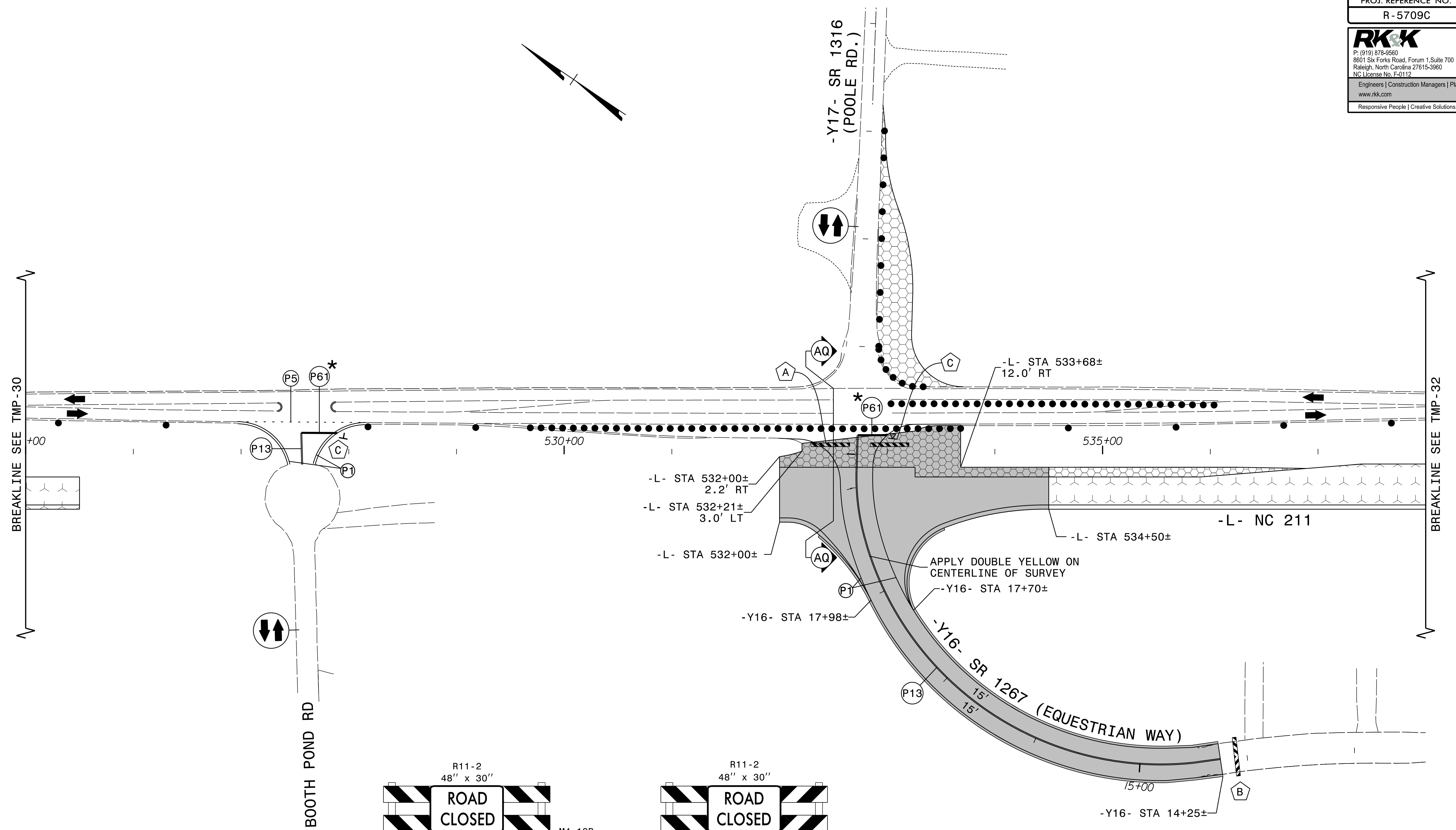

SEE TMP-31A FOR SECTION VIEW.
 SEE TMP-1J FOR -Y16 EQUESTRIAN WAY OFFSITE DETOUR.
 * SET BACK STOP BAR 10' FROM NC 211.
 ERECT STOP SIGN (R1-1 36"X36") ON EQUESTRIAN WAY PRIOR TO OPENING.

APPROVED: Kevin W. Bisby
 DATE: 10/15/2024
 SEAL
 NORTH CAROLINA PROFESSIONAL ENGINEER
 SEAL 21047
 KEVIN W. BISBY

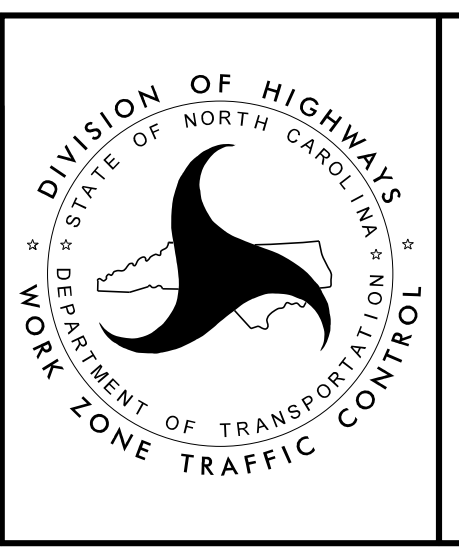

PHASE I
 STEP 3 DETAILS

PROJ. REFERENCE NO.	SHEET NO.
R-5709C	TMP-31A

RK&K
 P: (919) 878-8560
 8601 Six Forks Road, Forum 1, Suite 700
 Raleigh, North Carolina 27615-3960
 NC License No. F-0112
 Engineers | Construction Managers | Planners | Scientists
 www.rkk.com
 Responsive People | Creative Solutions

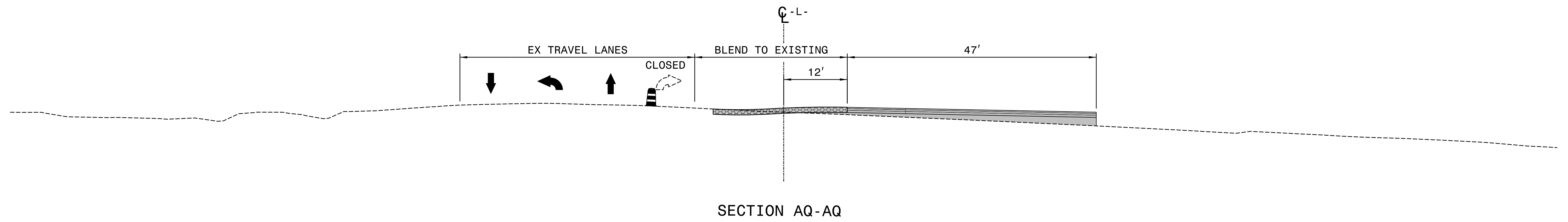

8/28/2024
 R-5709C_TMP-31A.dgn
 Rolsby

APPROVED: *Kevin W. Bisby*
Signed by: 382F8CA2F364404

DATE: 10/15/2024

SEAL

PROFESSIONAL ENGINEER
 KEVIN W. BISBY
 SEAL 21047
 NORTH CAROLINA

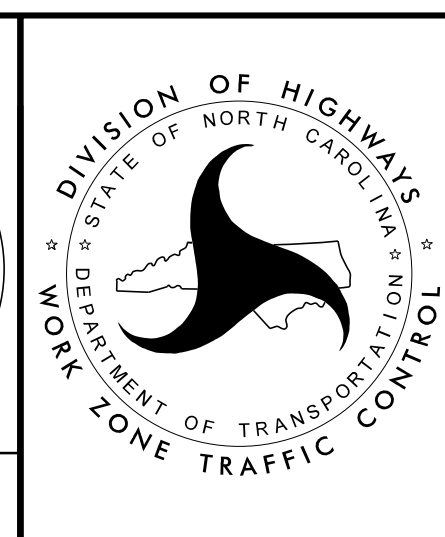

PHASE I
 STEP 3 DETAILS

**DOCUMENT NOT CONSIDERED FINAL
 UNLESS ALL SIGNATURES COMPLETED**

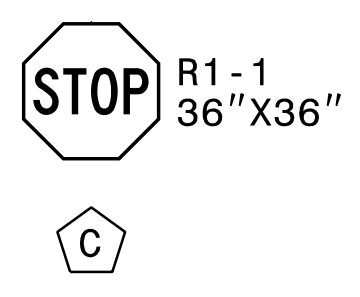
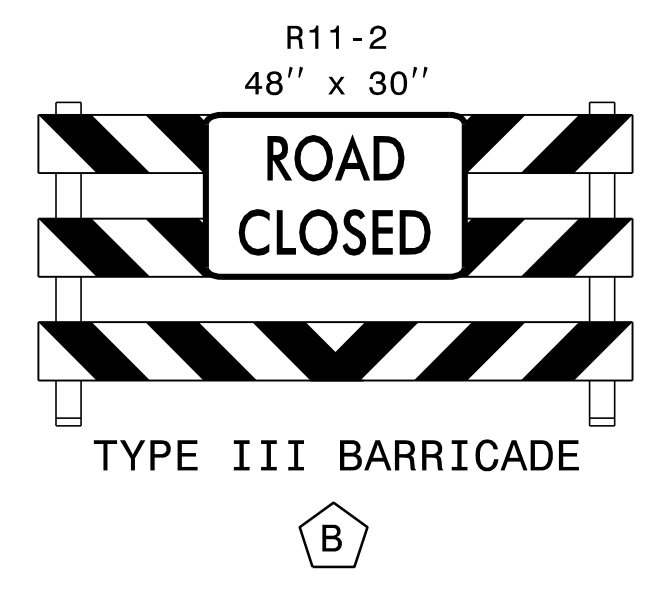
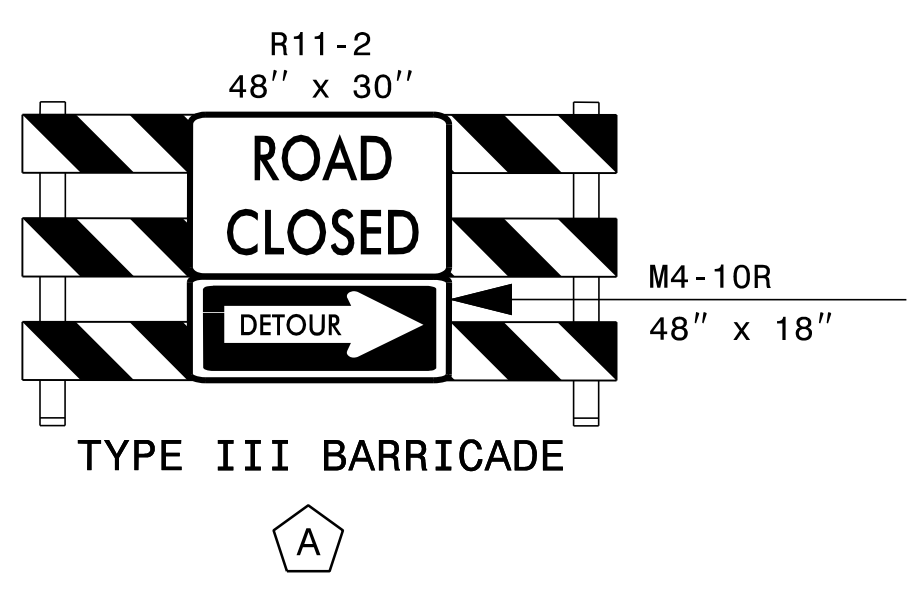
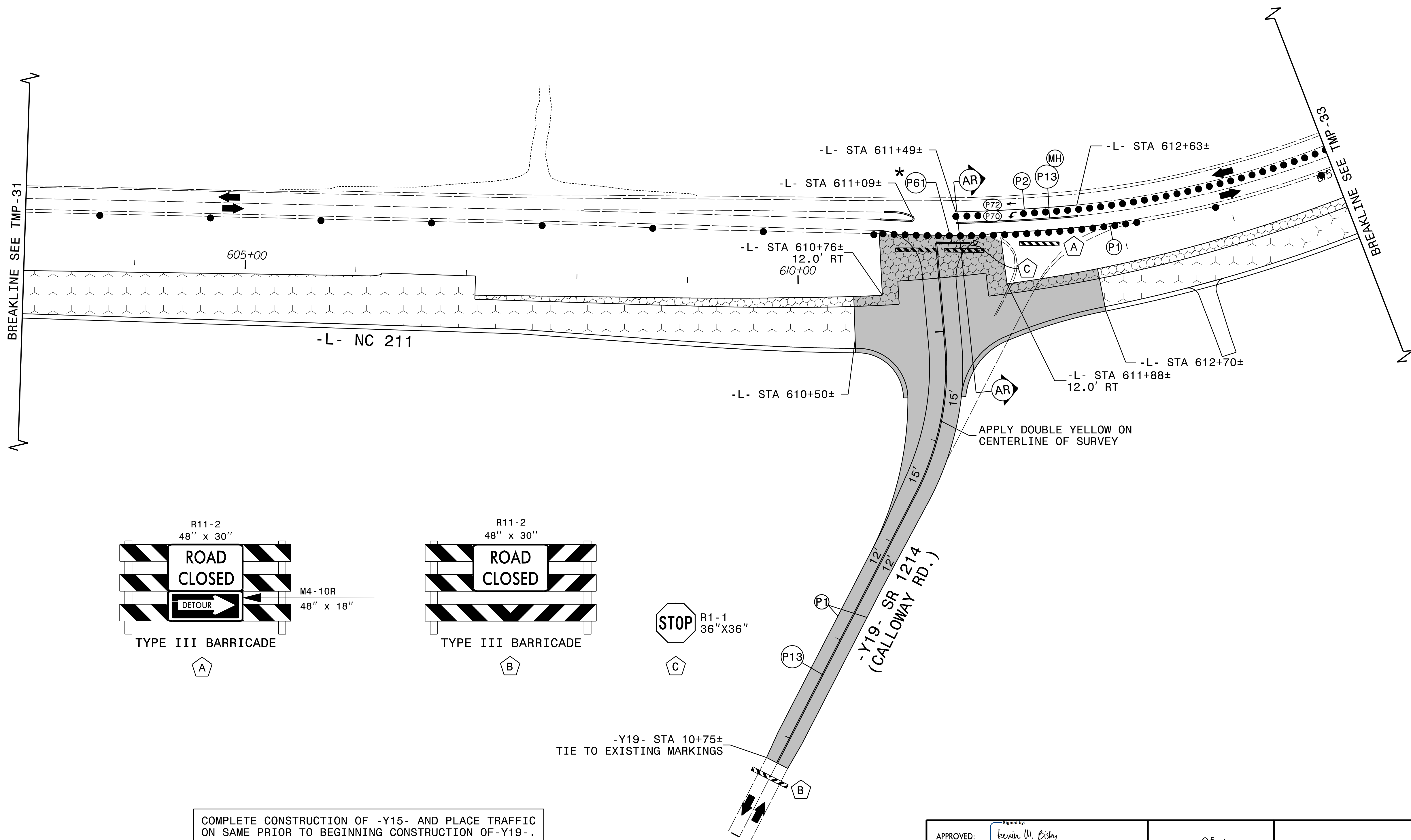

COMPLETE CONSTRUCTION OF -Y15- AND PLACE TRAFFIC ON SAME PRIOR TO BEGINNING CONSTRUCTION OF -Y19- .
 SEE TMP-1F FOR -Y19- CALLOWAY RD OFFSITE DETOUR.
 SEE TMP-32A FOR SECTION VIEW.
 * SET BACK STOP BAR 10' FROM NC 211.
 ERECT STOP SIGN (R1-1 36"X36") ON CALLOWAY RD PRIOR TO OPENING.

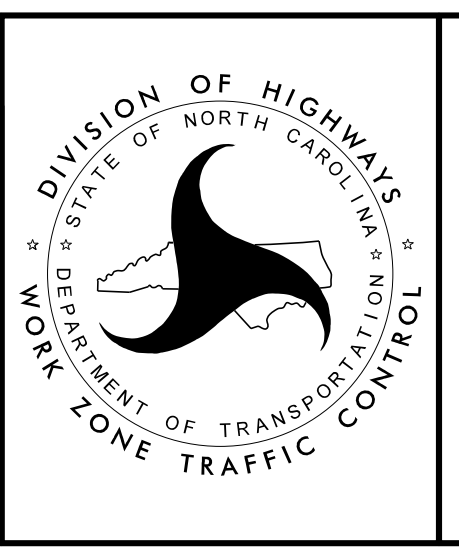

APPROVED: *Kevin W. Bisby*
 DATE: 10/15/2024
 SEAL
 NORTH CAROLINA PROFESSIONAL ENGINEER
 SEAL 21047
 KEVIN W. BISBY

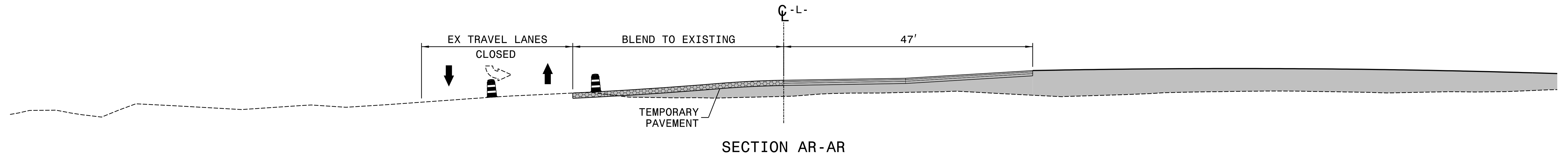

PHASE I
 STEP 3 DETAILS

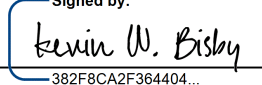

8/28/2024
 RST05_TMP_psh32A.dgn
 RStebby

APPROVED:  <small>382F8CA2F364404</small> DATE: 10/15/2024 SEAL		 <p style="text-align: center;">PHASE I STEP 3 DETAILS</p>
DOCUMENT NOT CONSIDERED FINAL UNLESS ALL SIGNATURES COMPLETED		

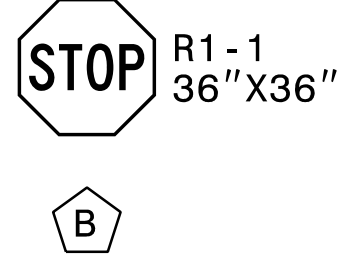
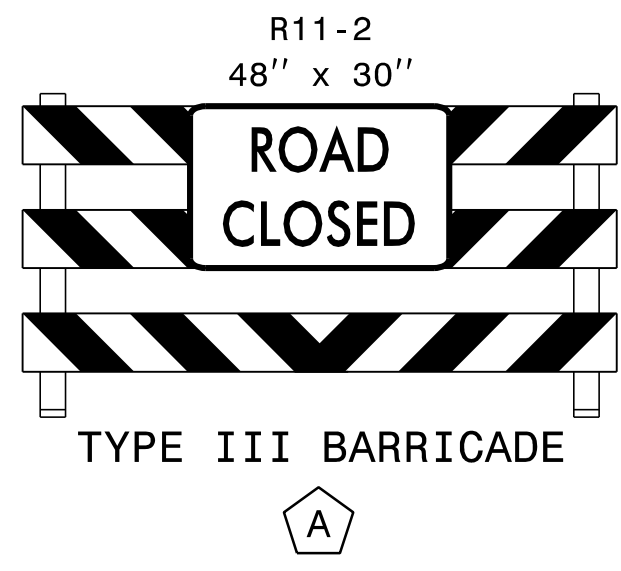
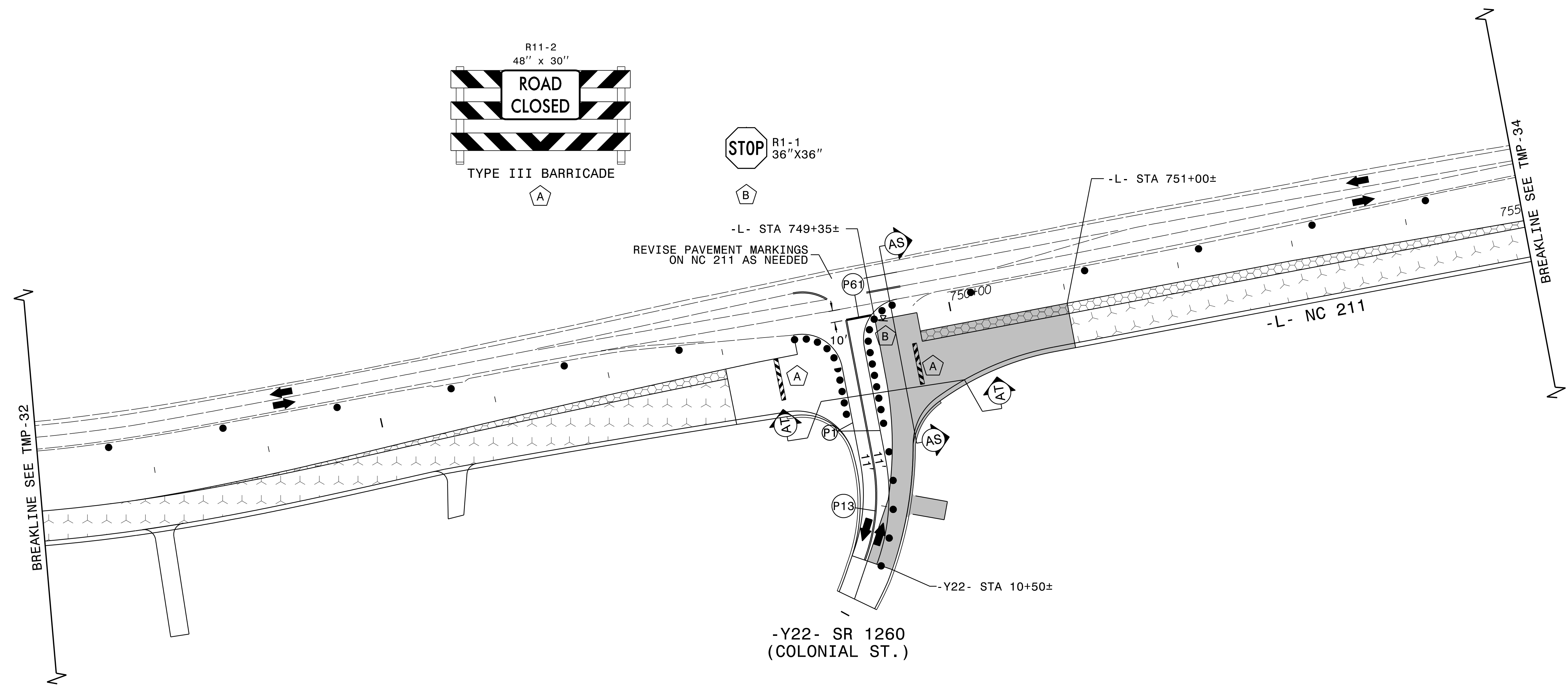
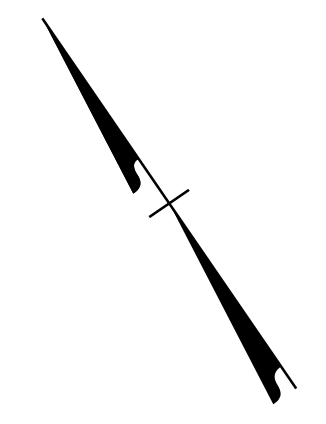

-L- STA 749+35±
 REVISE PAVEMENT MARKINGS
 ON NC 211 AS NEEDED

-L- STA 751+00±

-L- NC 211

-Y22- STA 10+50±

-Y22- SR 1260
 (COLONIAL ST.)

BREAKLINE SEE TMP-32

BREAKLINE SEE TMP-34

SEE TMP-33A FOR SECTION VIEWS

8/28/2024
 RST05_TMP_psh33.dgn
 Rolsby

APPROVED: *Kevin W. Bisby*
 DATE: 10/15/2024

SEAL

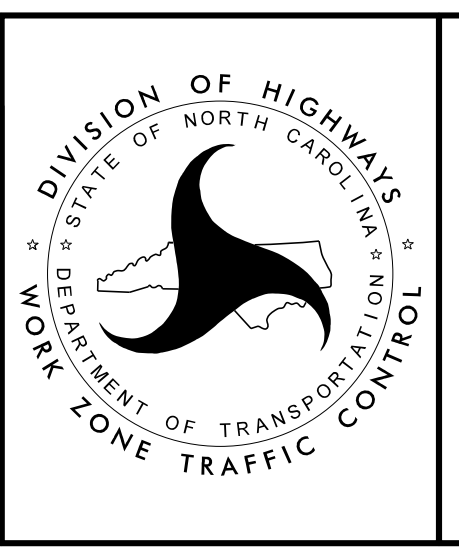

PHASE I
 STEP 3 DETAILS



DOCUMENT NOT CONSIDERED FINAL
 UNLESS ALL SIGNATURES COMPLETED

PROJ. REFERENCE NO.	SHEET NO.
R-5709C	TMP-33A

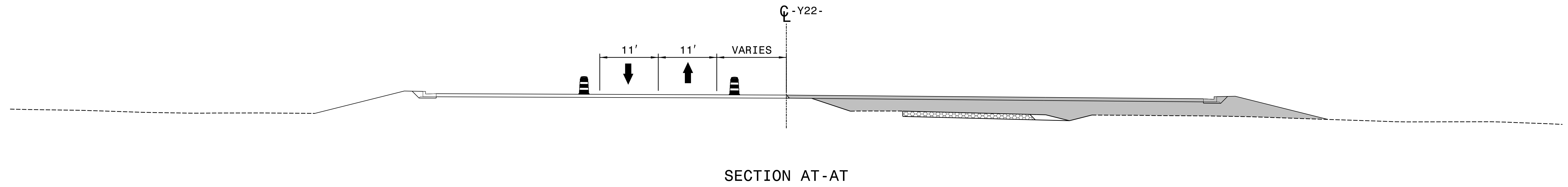
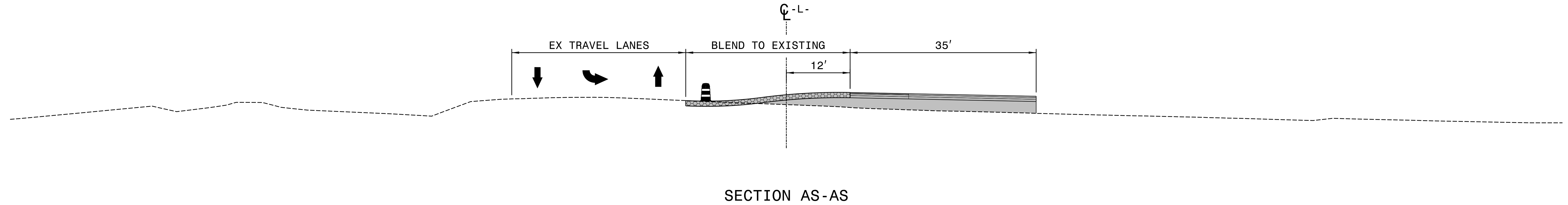
RKK
 P: (919) 878-8560
 8601 Six Forks Road, Forum 1, Suite 700
 Raleigh, North Carolina 27615-3960
 NC License No. F-0112
 Engineers | Construction Managers | Planners | Scientists
 www.rkk.com
 Responsive People | Creative Solutions



8/28/2024
 RST05_TMP_psh33A.dgn
 R01sby

APPROVED: <u>Kevin W. Bisby</u> <small>3878CAZP982404</small> DATE: 10/15/2024 <div style="text-align: center; margin-top: 10px;">  SEAL </div>		<h2 style="margin: 0;">PHASE I STEP 3 DETAILS</h2>
DOCUMENT NOT CONSIDERED FINAL UNLESS ALL SIGNATURES COMPLETED		

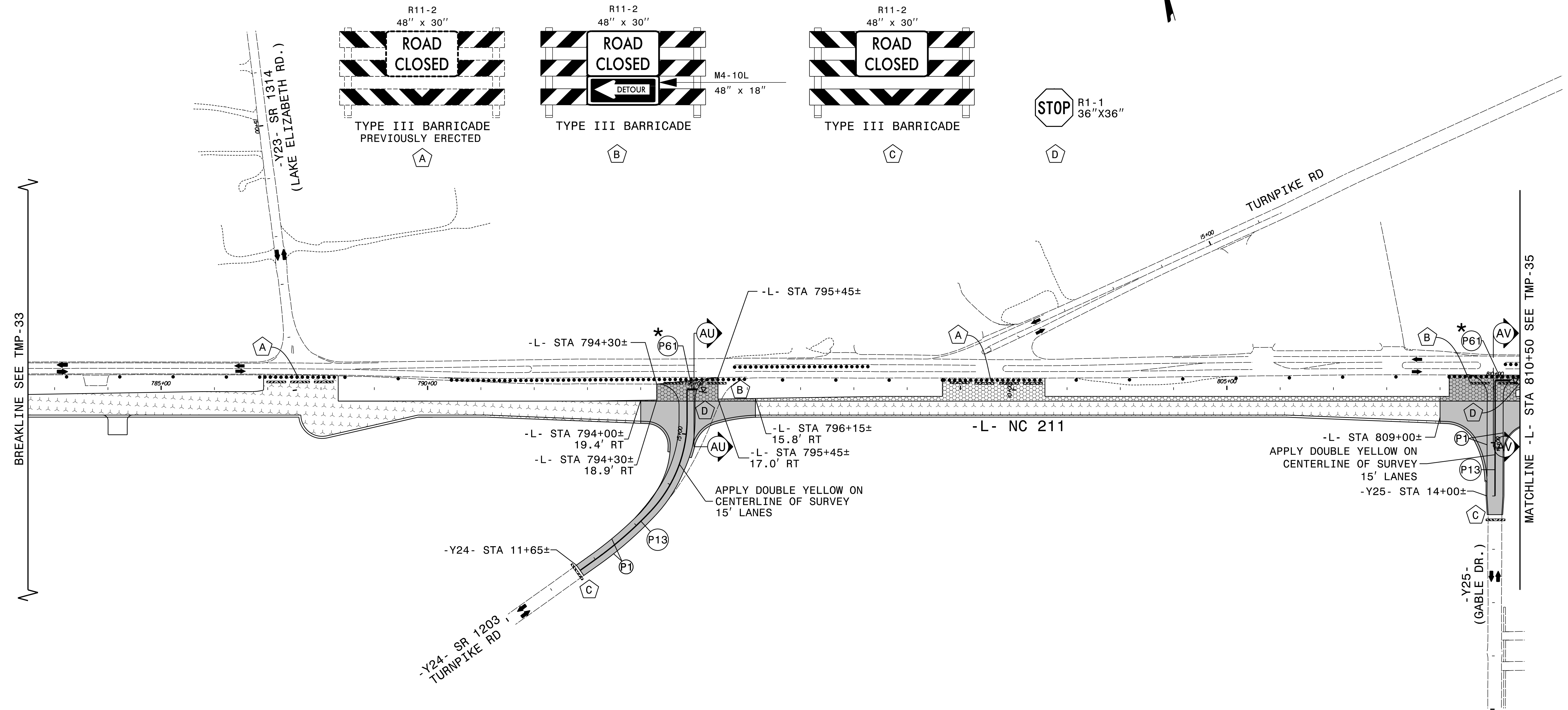

SEE TMP-34A FOR SECTION VIEWS
 SEE TMP-1G FOR -Y24- TURNPIKE RD OFFSITE DETOUR.
 SEE TMP-1H FOR -Y25- GABLE DR OFFSITE DETOUR.
 * SET BACK STOP BAR 10' FROM NC 211.
 ERECT STOP SIGN (R1-1 36"X36") ON TURNPIKE RD
 AND GABLE DR PRIOR TO OPENING.

APPROVED: *Kevin W. Bisby*
 DATE: 10/15/2024
 SEAL
 NORTH CAROLINA PROFESSIONAL ENGINEER
 SEAL 21047
 KEVIN W. BISBY

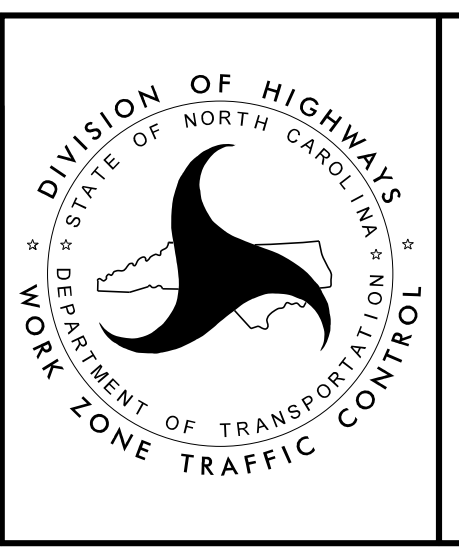

PHASE I
 STEP 3 DETAILS

PROJ. REFERENCE NO.	SHEET NO.
R-5709C	TMP-34A

RKK
 P: (919) 878-8560
 8601 Six Forks Road, Forum 1, Suite 700
 Raleigh, North Carolina 27615-3960
 NC License No. F-0112
 Engineers | Construction Managers | Planners | Scientists
 www.rkk.com
 Responsive People | Creative Solutions

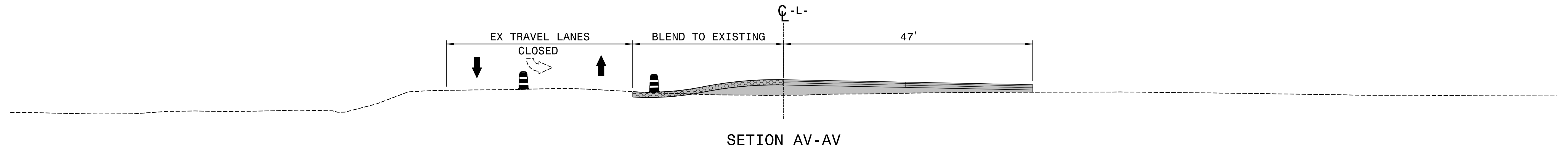
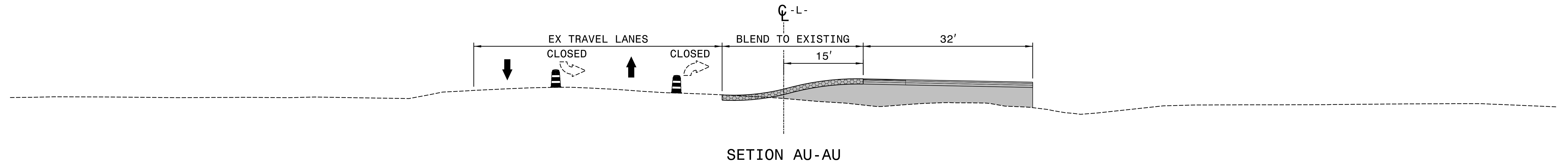

8/28/2024
 RST05_TMP_psh34A.dgn
 R015by

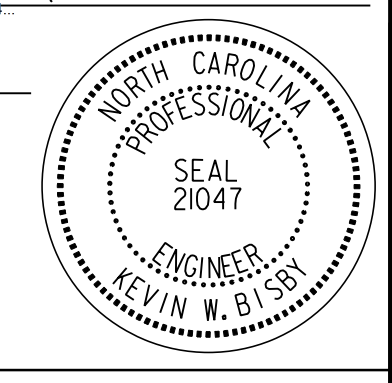
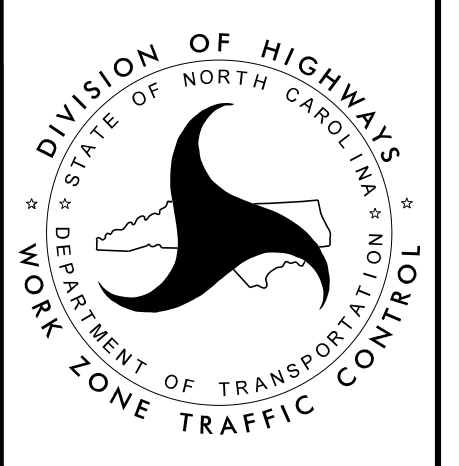
APPROVED: <u>Kevin W. Bisby</u> DATE: 10/15/2024 SEAL 		<p>PHASE I STEP 3 DETAILS</p>
<p>DOCUMENT NOT CONSIDERED FINAL UNLESS ALL SIGNATURES COMPLETED</p>		

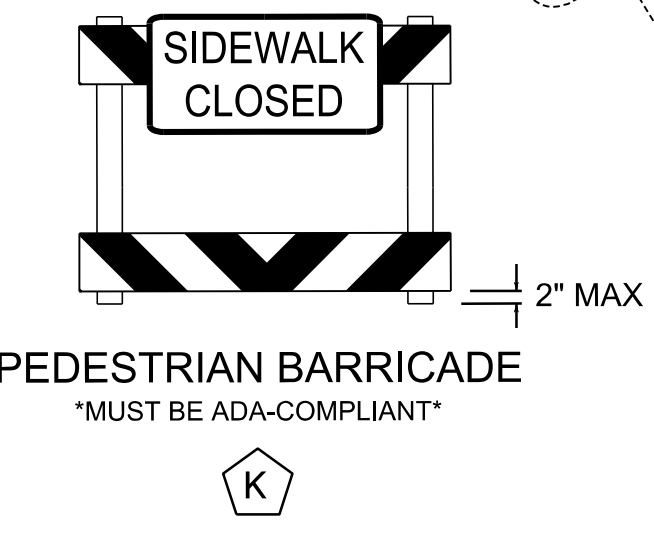
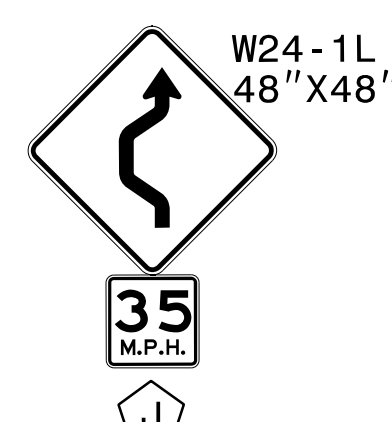
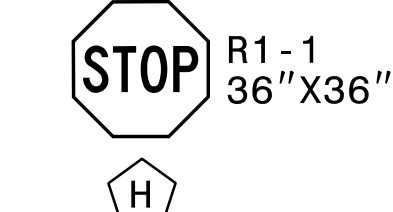
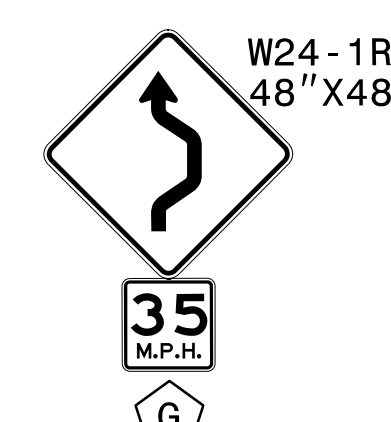
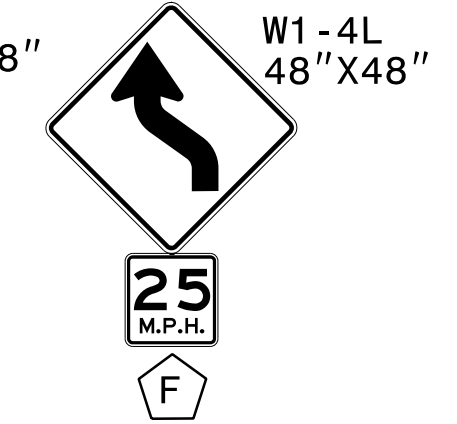
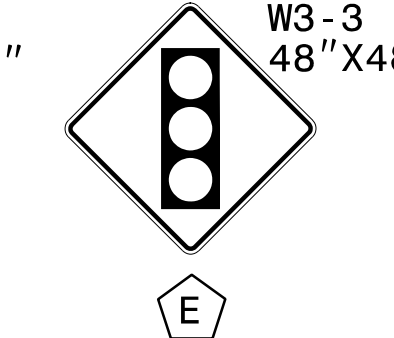
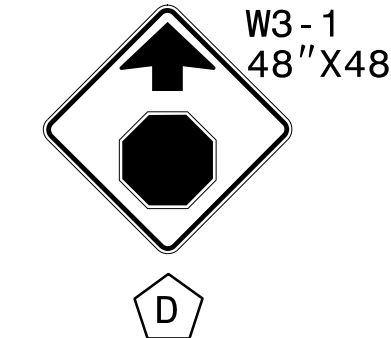
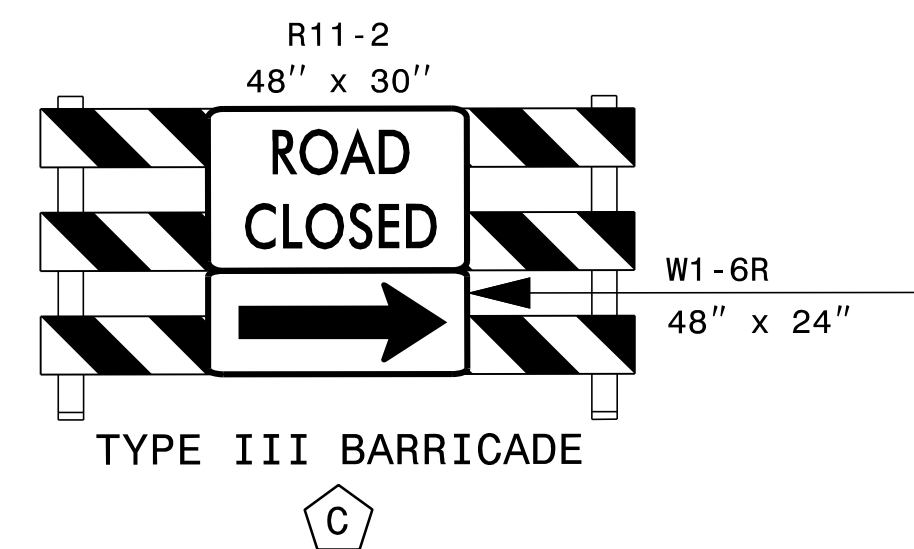
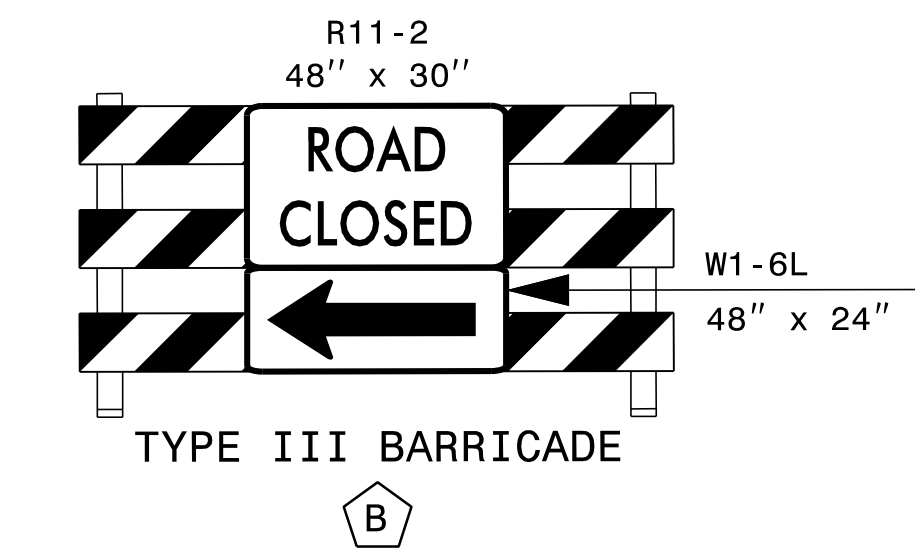
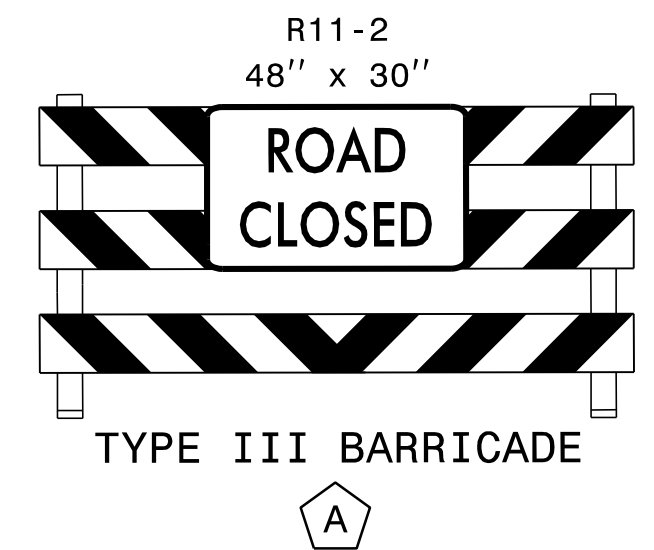
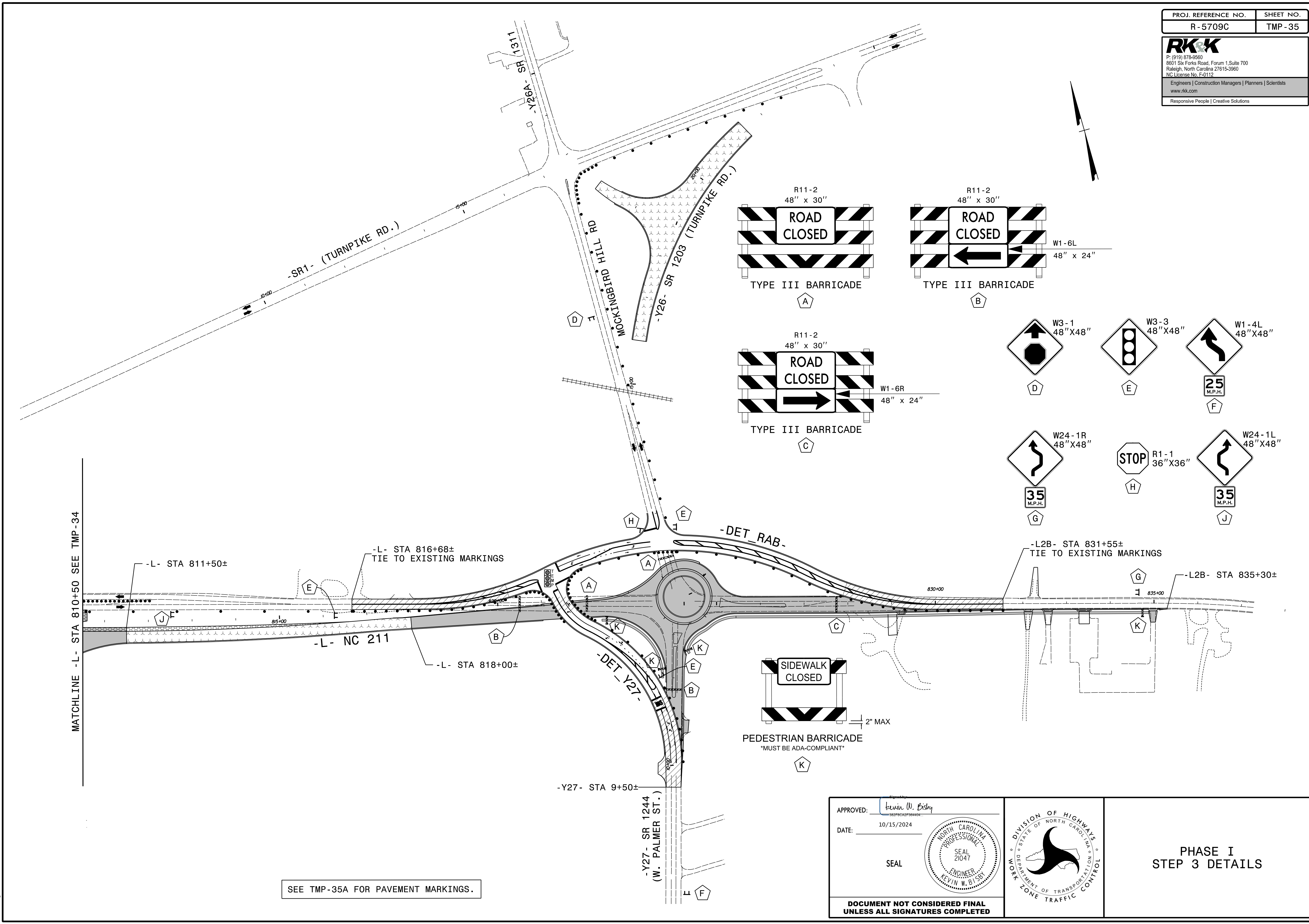

MATCHLINE - L- STA 810+50 SEE TMP-34

SEE TMP-35A FOR PAVEMENT MARKINGS.

APPROVED: *Kevin W. Bisby*
 DATE: 10/15/2024

SEAL

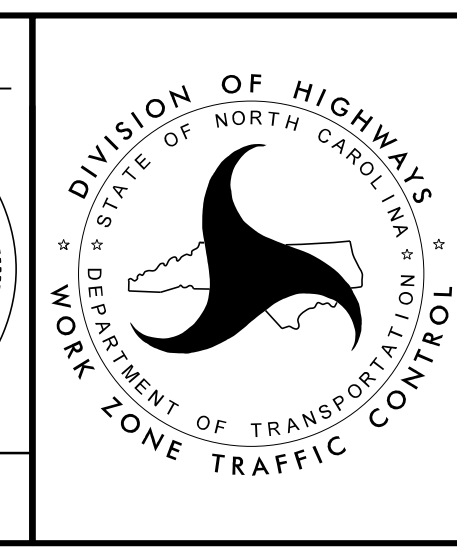

PHASE I
STEP 3 DETAILS

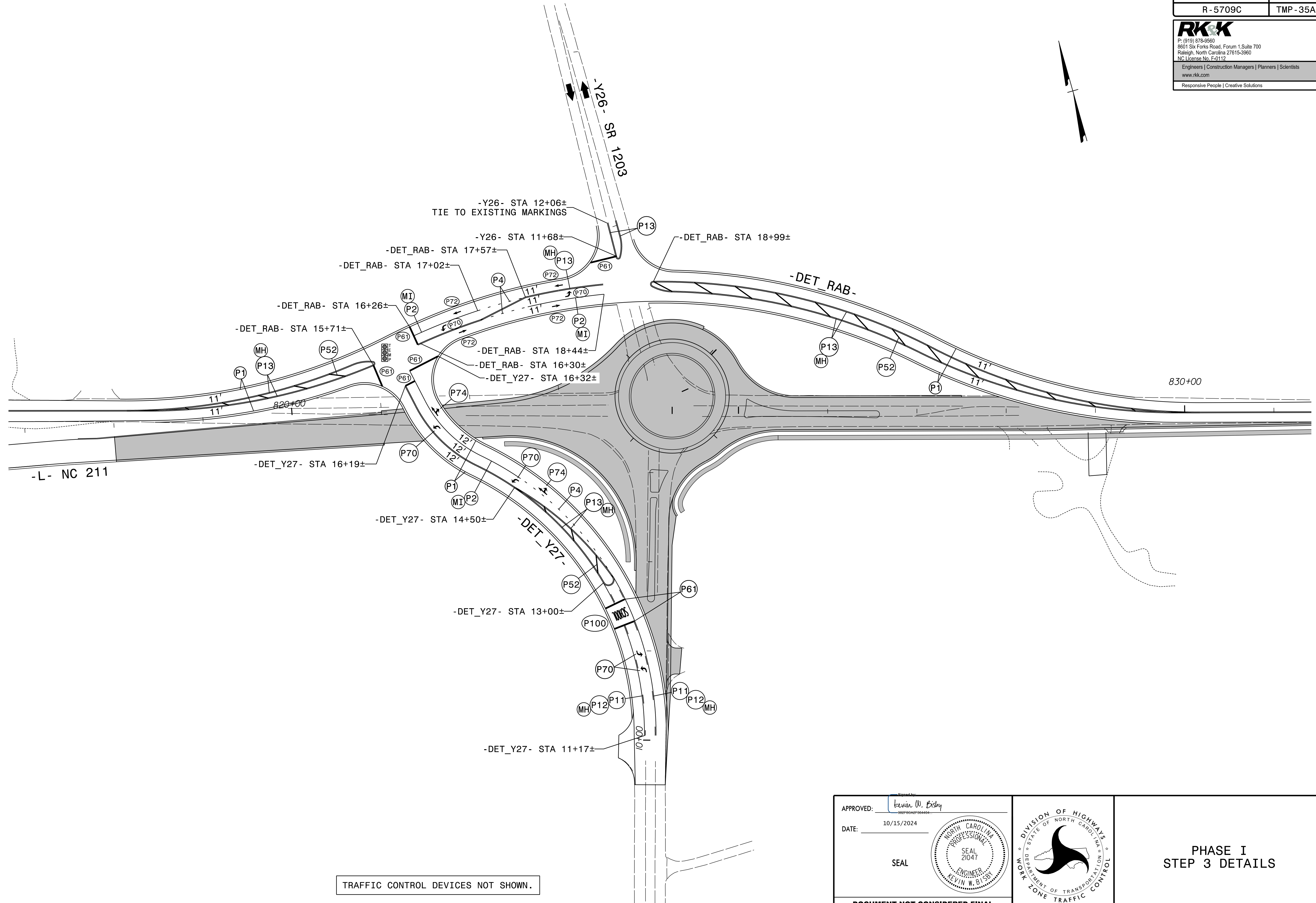

-L- NC 211

830+00

TRAFFIC CONTROL DEVICES NOT SHOWN.

APPROVED: Kevin W. Bisby
 DATE: 10/15/2024
 SEAL
 NORTH CAROLINA PROFESSIONAL ENGINEER
 SEAL 21047
 KEVIN W. BISBY

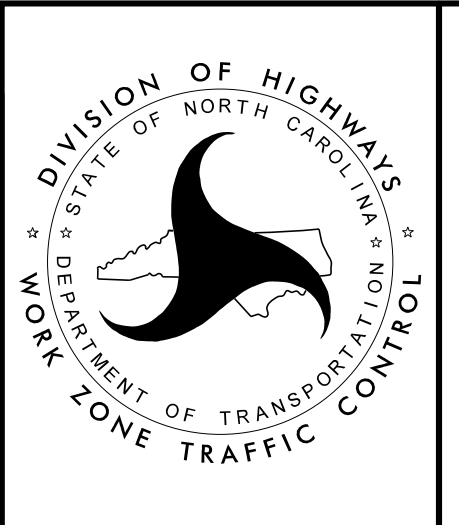

PHASE I
 STEP 3 DETAILS

8/28/2024
 RST05_TMP_psh35A.dgn
 RStebby

DOCUMENT NOT CONSIDERED FINAL
 UNLESS ALL SIGNATURES COMPLETED

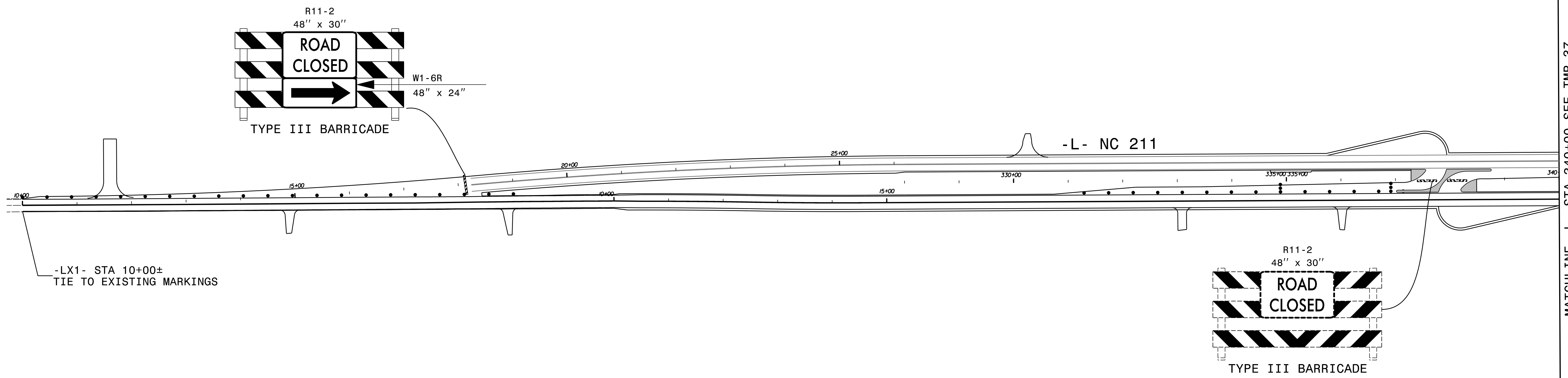
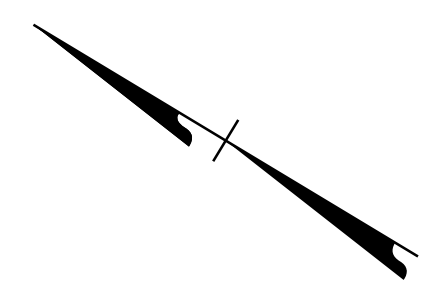

8/28/2024
 RST05_TMP_PSH36.dgn
 R01sby

12' LANES

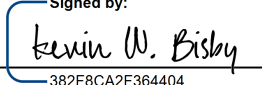
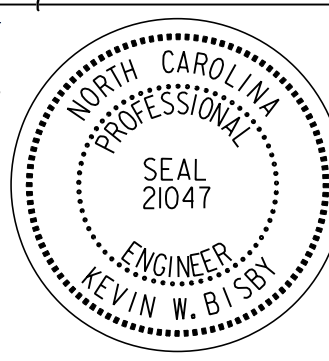
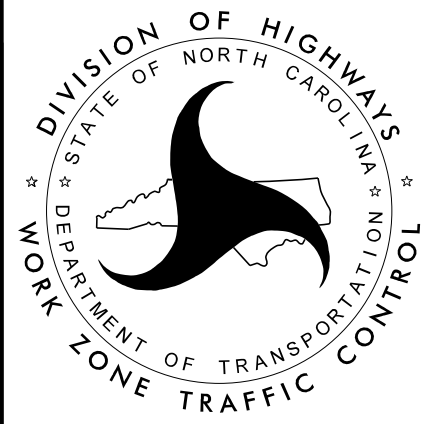
APPROVED:  DATE: 10/15/2024 SEAL	 	<p>PHASE II STEP 1 DETAIL</p>
<p>DOCUMENT NOT CONSIDERED FINAL UNLESS ALL SIGNATURES COMPLETED</p>		

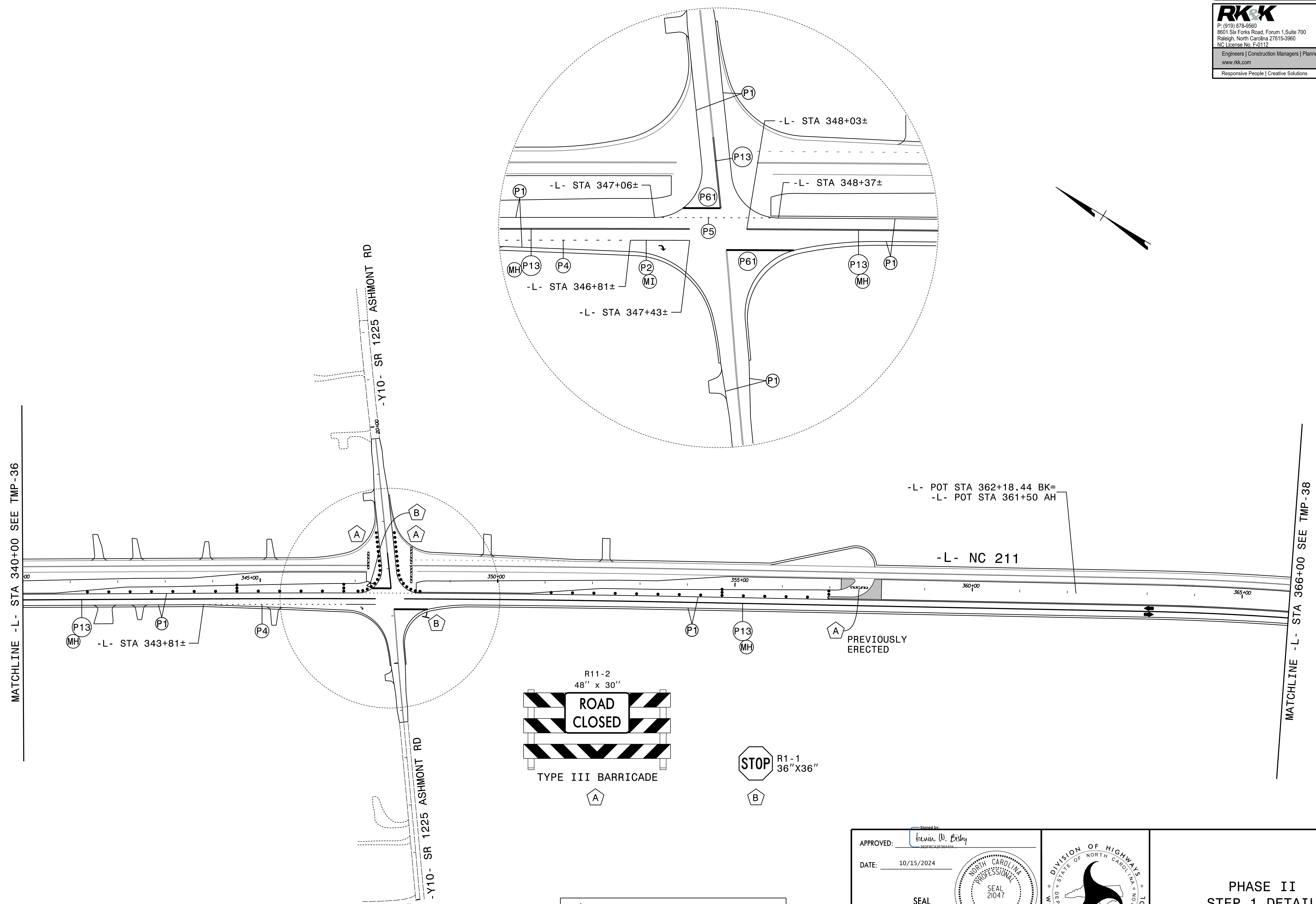

MATCHLINE -L- STA 340+00 SEE TMP-36

MATCHLINE -L- STA 366+00 SEE TMP-38

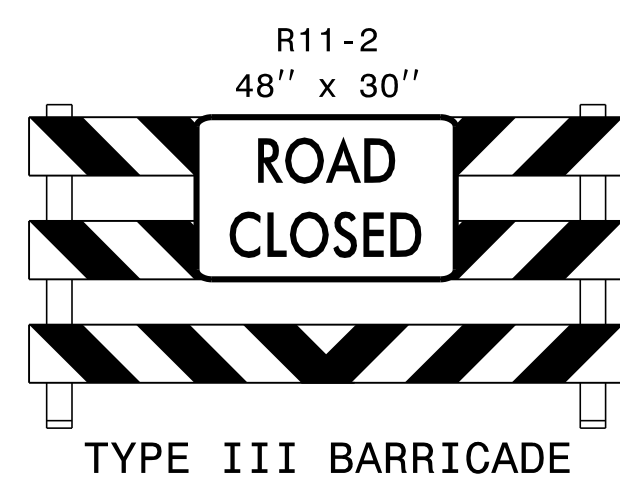

12' LANES
 * SET BACK STOP BAR 10' FROM NC 211.

-L- POT STA 362+18.44 BK=
 -L- POT STA 361+50 AH

-L- NC 211

PREVIOUSLY ERECTED

8/28/2024
 RST05_TMP_PSH37.dgn
 Rolsby

APPROVED: *Kevin W. Bisby*
 DATE: 10/15/2024

SEAL

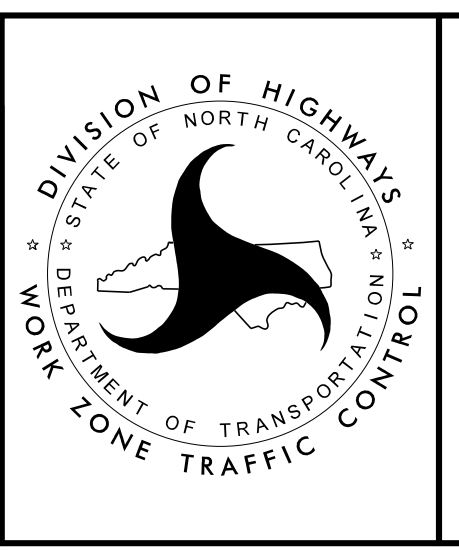

PHASE II
 STEP 1 DETAIL

DOCUMENT NOT CONSIDERED FINAL
 UNLESS ALL SIGNATURES COMPLETED

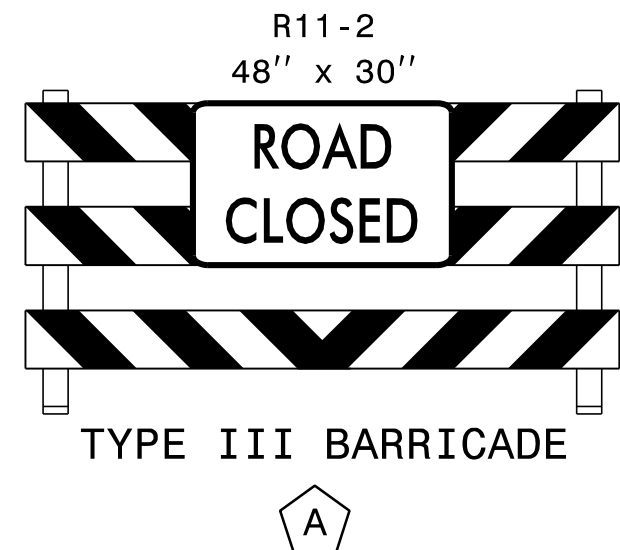
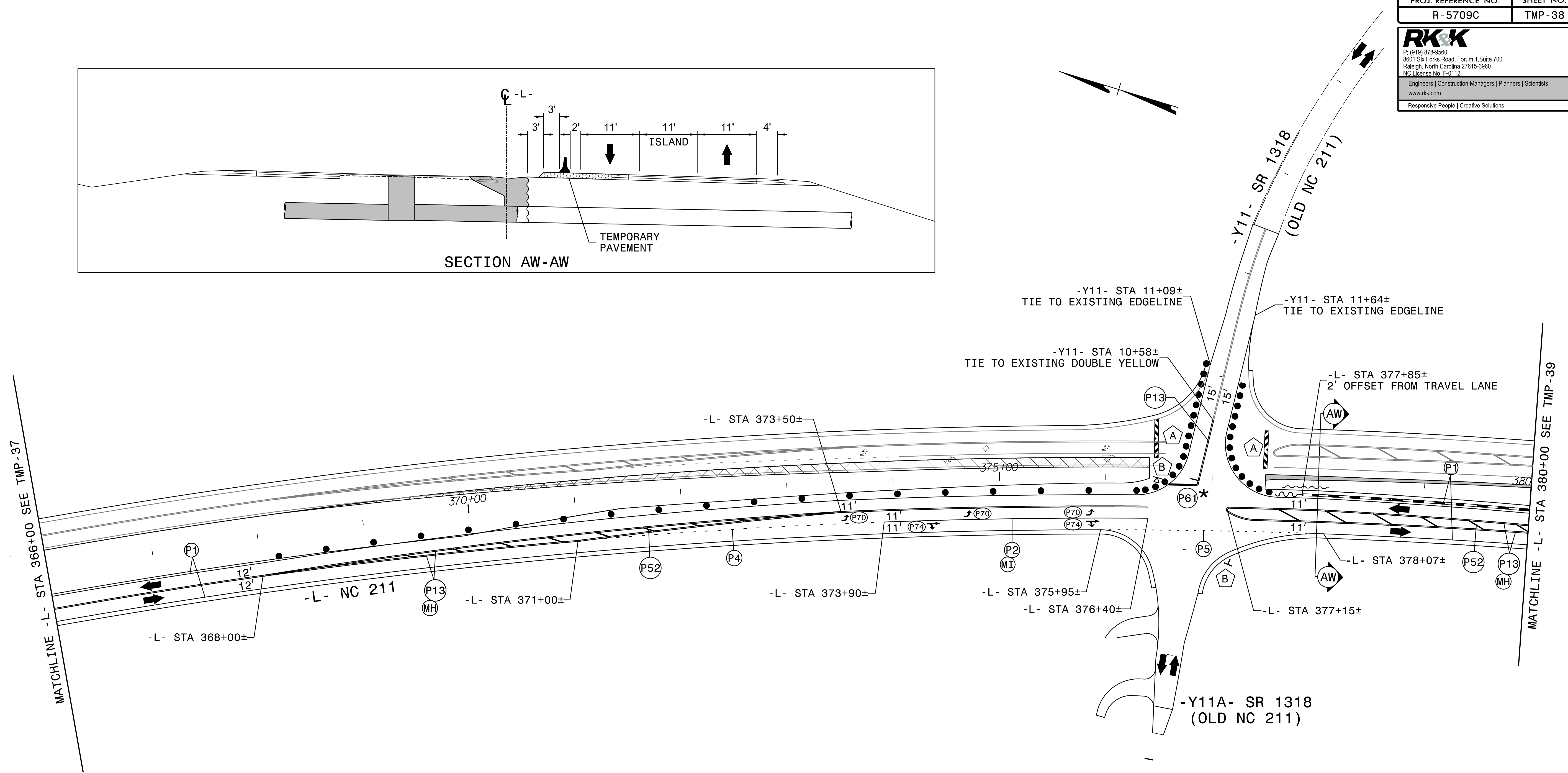
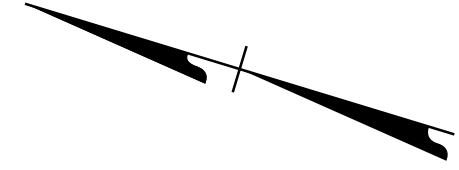
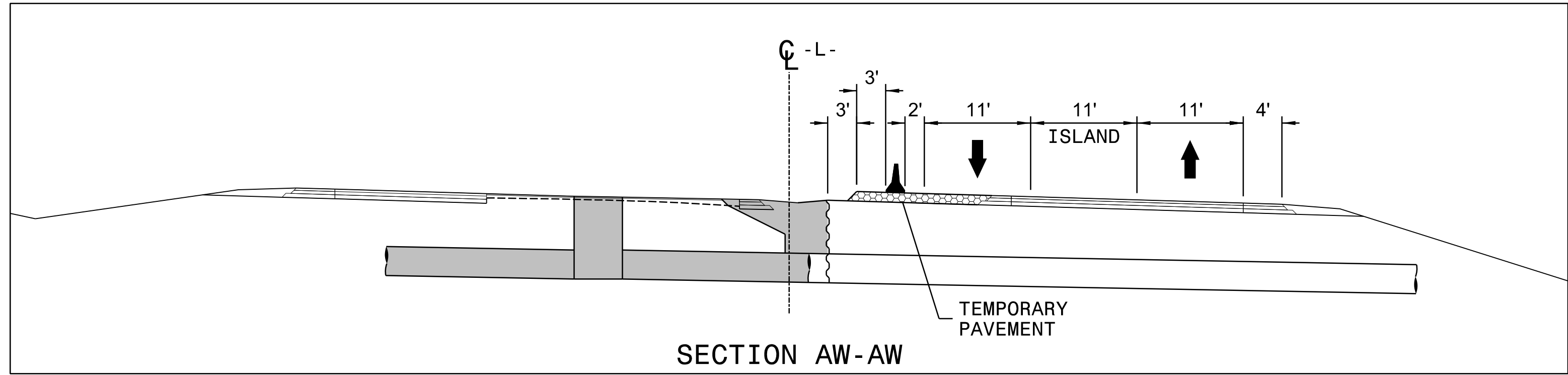

* SET BACK STOP BAR 10' FROM NC 211.

APPROVED: *Kevin W. Bisby*
 DATE: 10/15/2024
 SEAL
 NORTH CAROLINA PROFESSIONAL ENGINEER
 SEAL 21047
 KEVIN W. BISBY

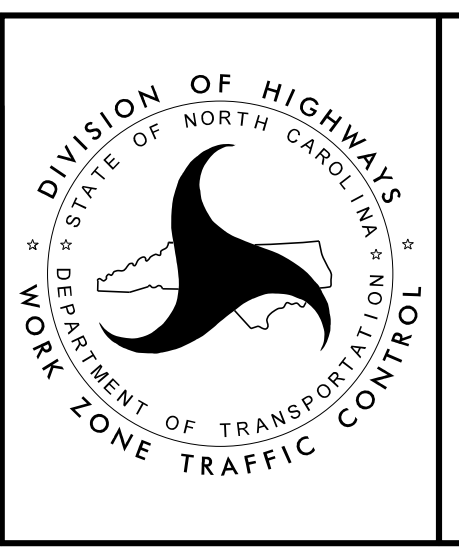

PHASE II
 STEP 1 DETAIL

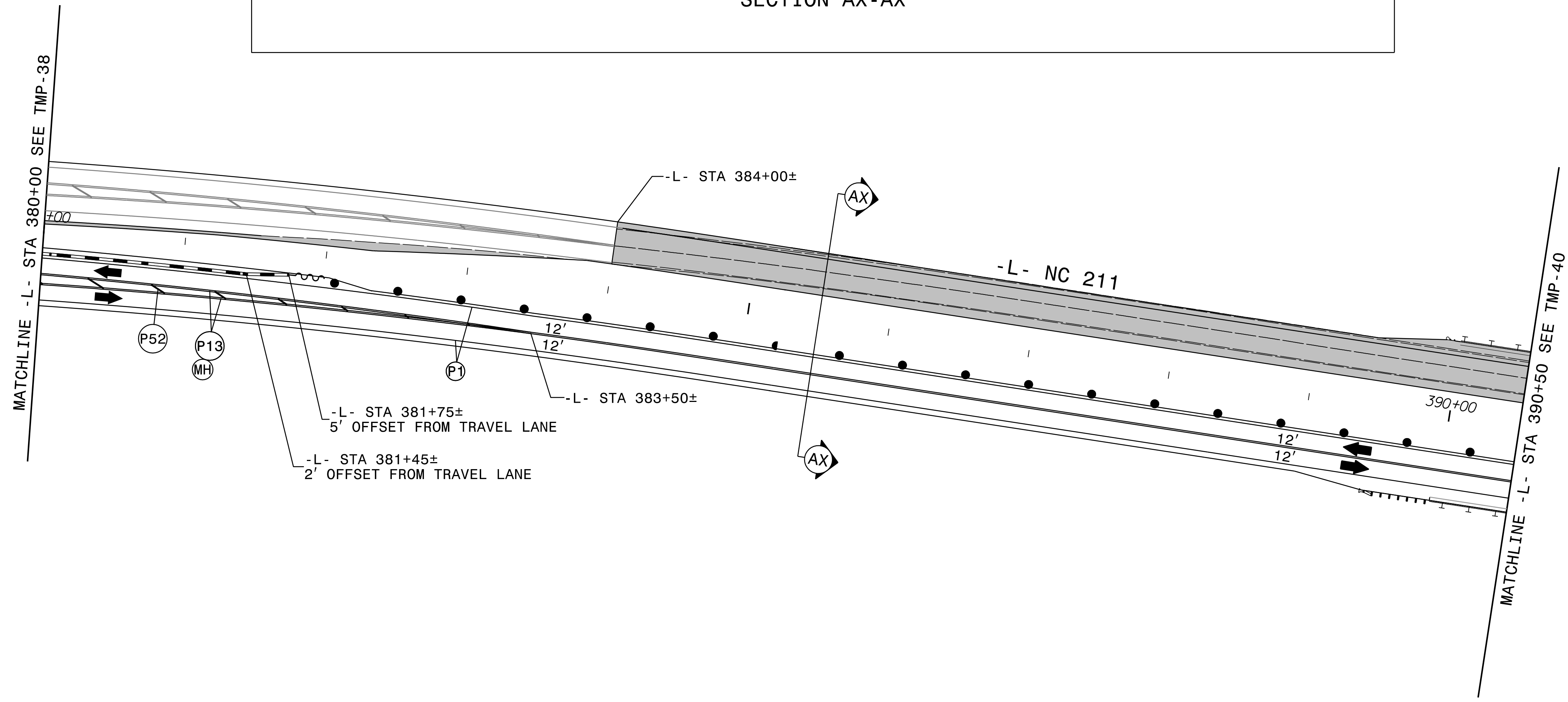
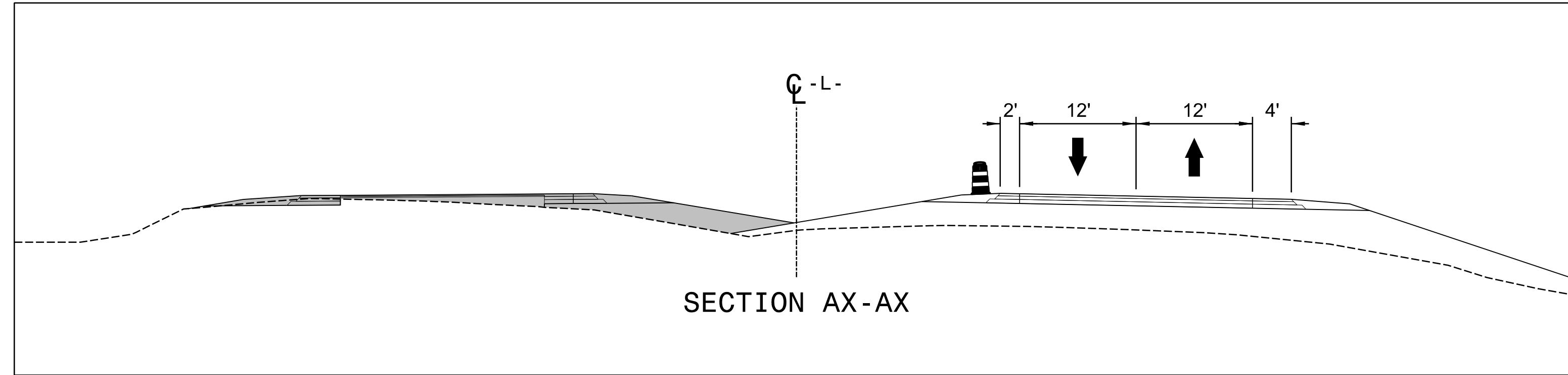
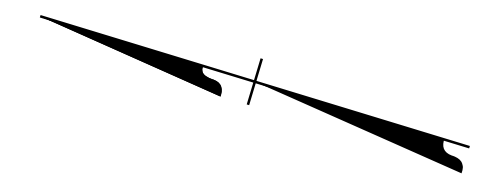

8/28/2024
 RST05_TMP_psh39.dgn
 Rolsby

APPROVED: Kevin W. Bisby
392PFCAP384404

DATE: 10/15/2024

SEAL

**DOCUMENT NOT CONSIDERED FINAL
 UNLESS ALL SIGNATURES COMPLETED**

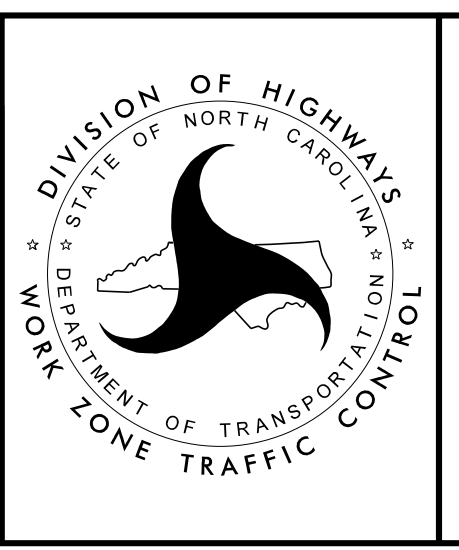

PHASE II
STEPS 1 AND 2 DETAILS

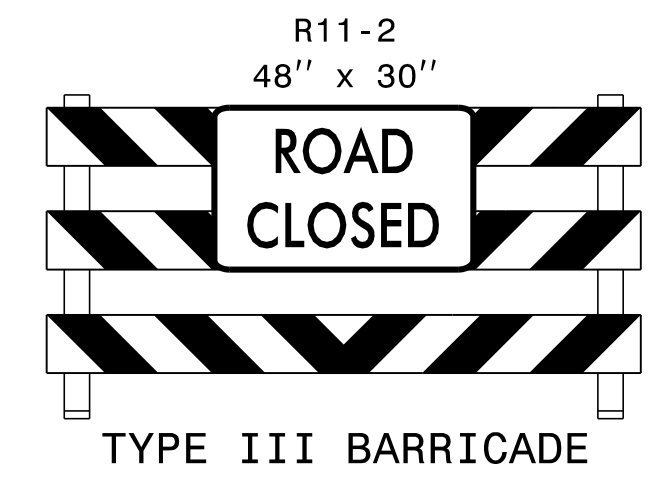
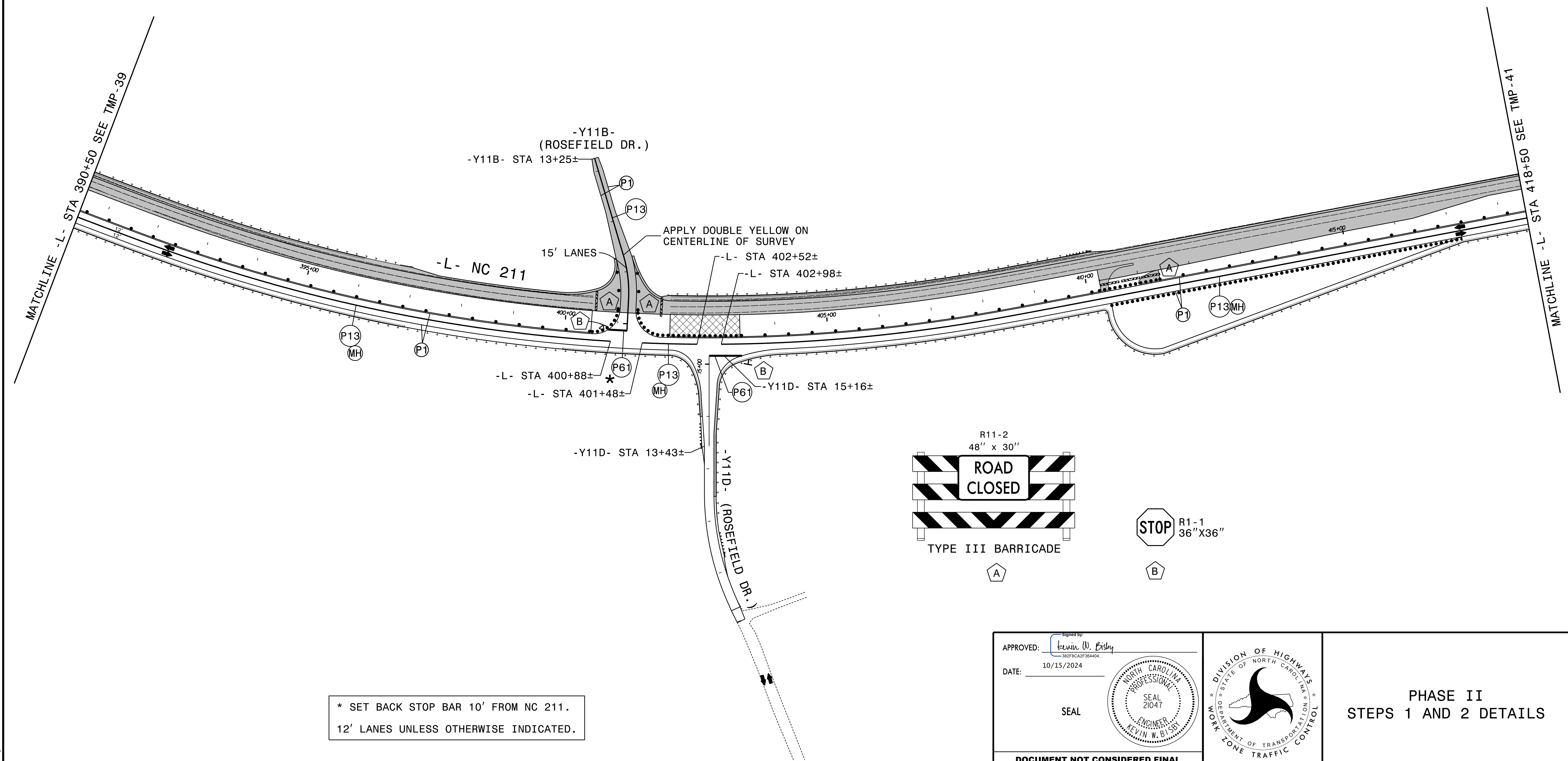
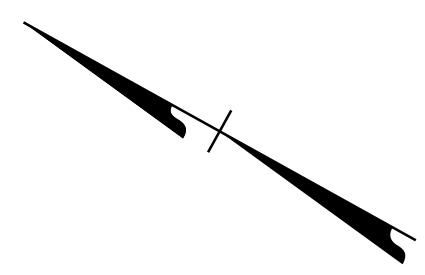

* SET BACK STOP BAR 10' FROM NC 211.
12' LANES UNLESS OTHERWISE INDICATED.

APPROVED: Kevin W. Bisby
DATE: 10/15/2024
SEAL

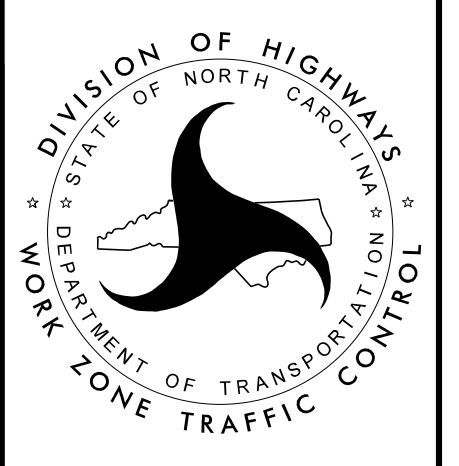
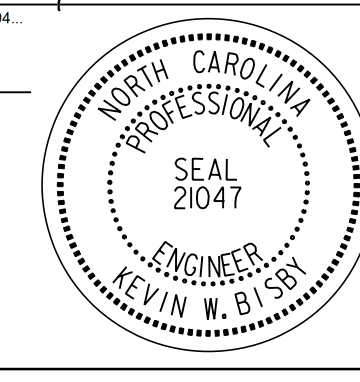

PHASE II
STEPS 1 AND 2 DETAILS

DOCUMENT NOT CONSIDERED FINAL
UNLESS ALL SIGNATURES COMPLETED

8/28/2024
RST05_TMP_psh40.dgn
Rolsby

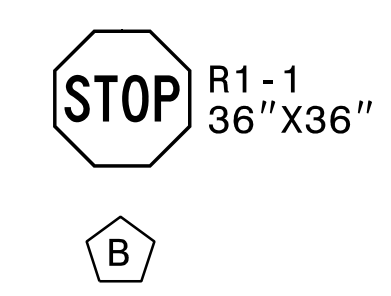
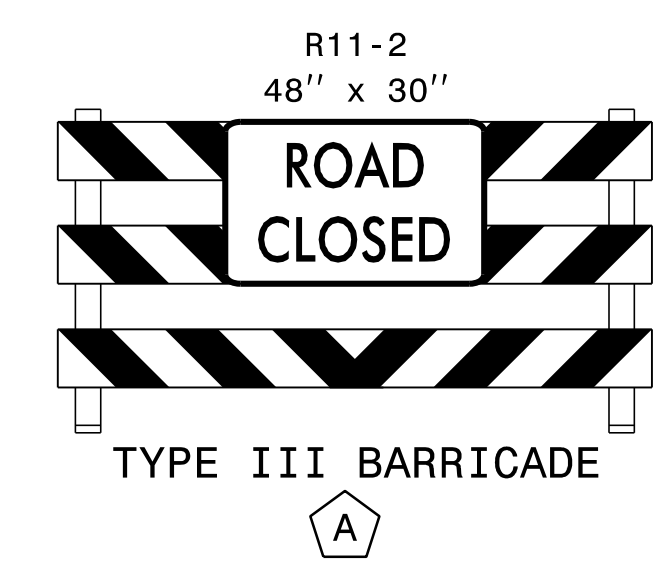
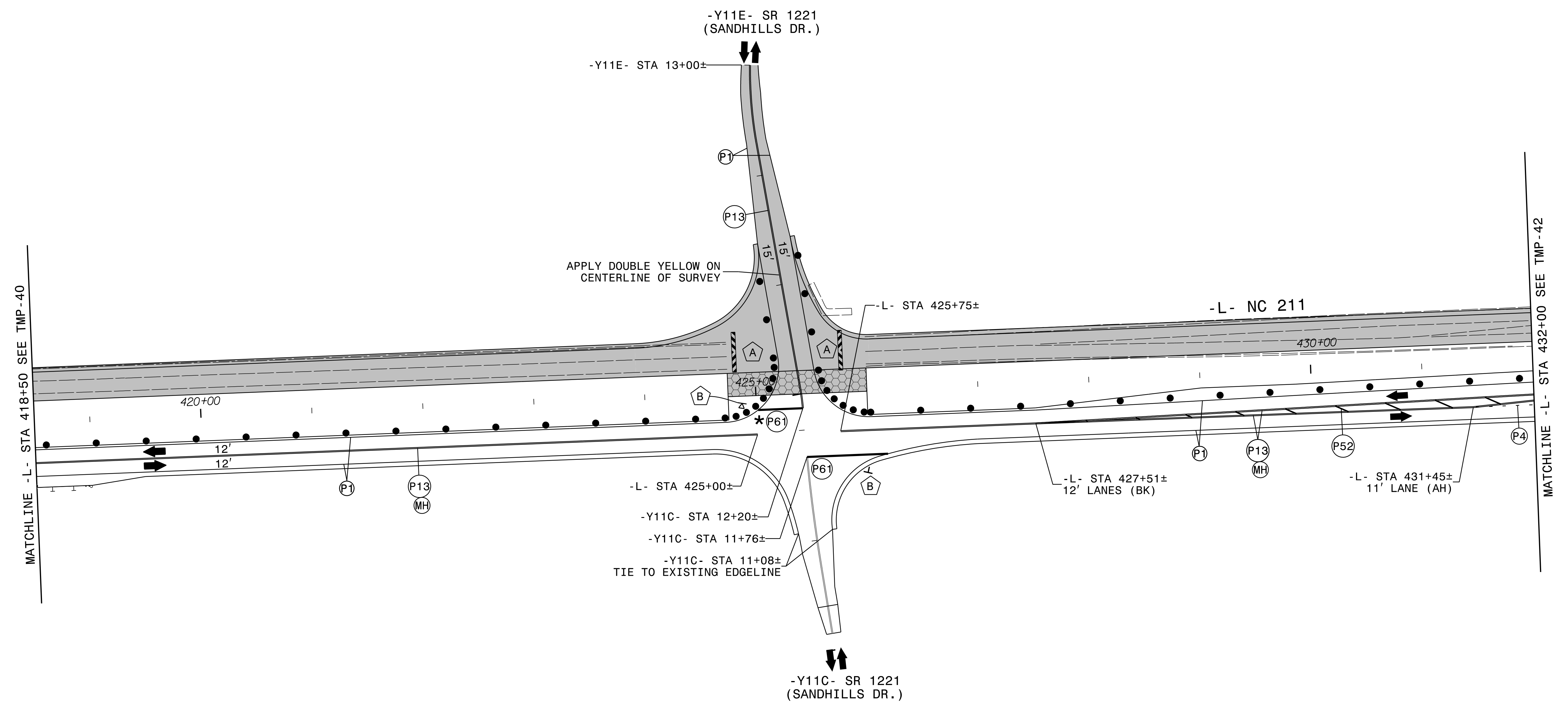
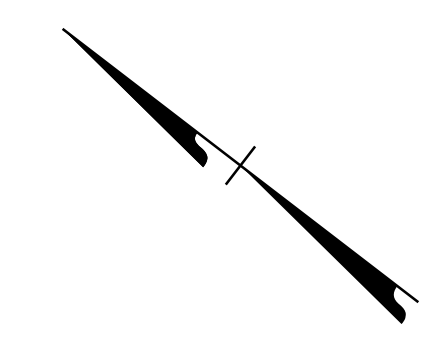

* SET BACK STOP BAR 10' FROM NC 211

APPROVED: Kevin W. Bisby
 DATE: 10/15/2024
 SEAL
 NORTH CAROLINA
 PROFESSIONAL
 SEAL
 21047
 ENGINEER
 KEVIN W. BISBY

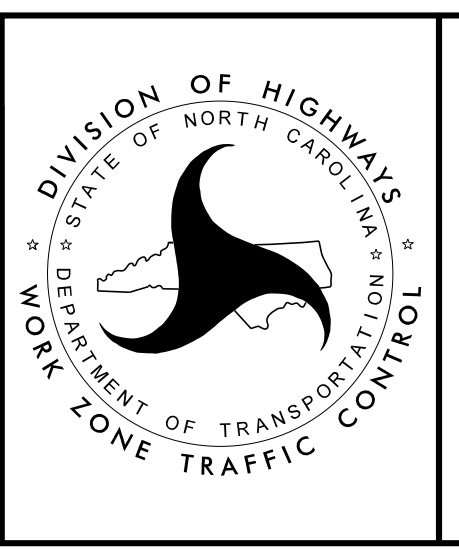

PHASE II
 STEPS 1 AND 2 DETAILS

DOCUMENT NOT CONSIDERED FINAL
 UNLESS ALL SIGNATURES COMPLETED

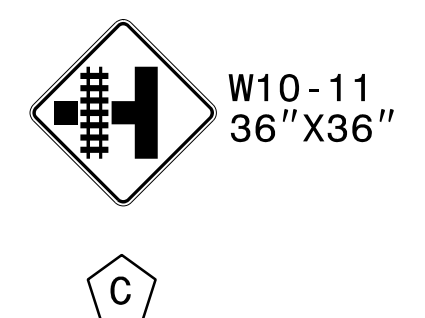
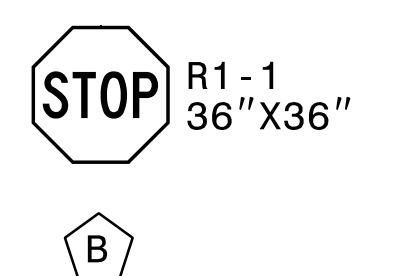
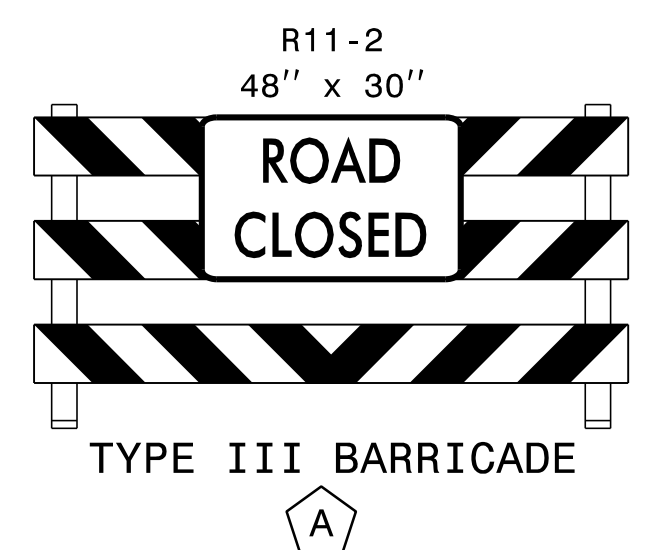
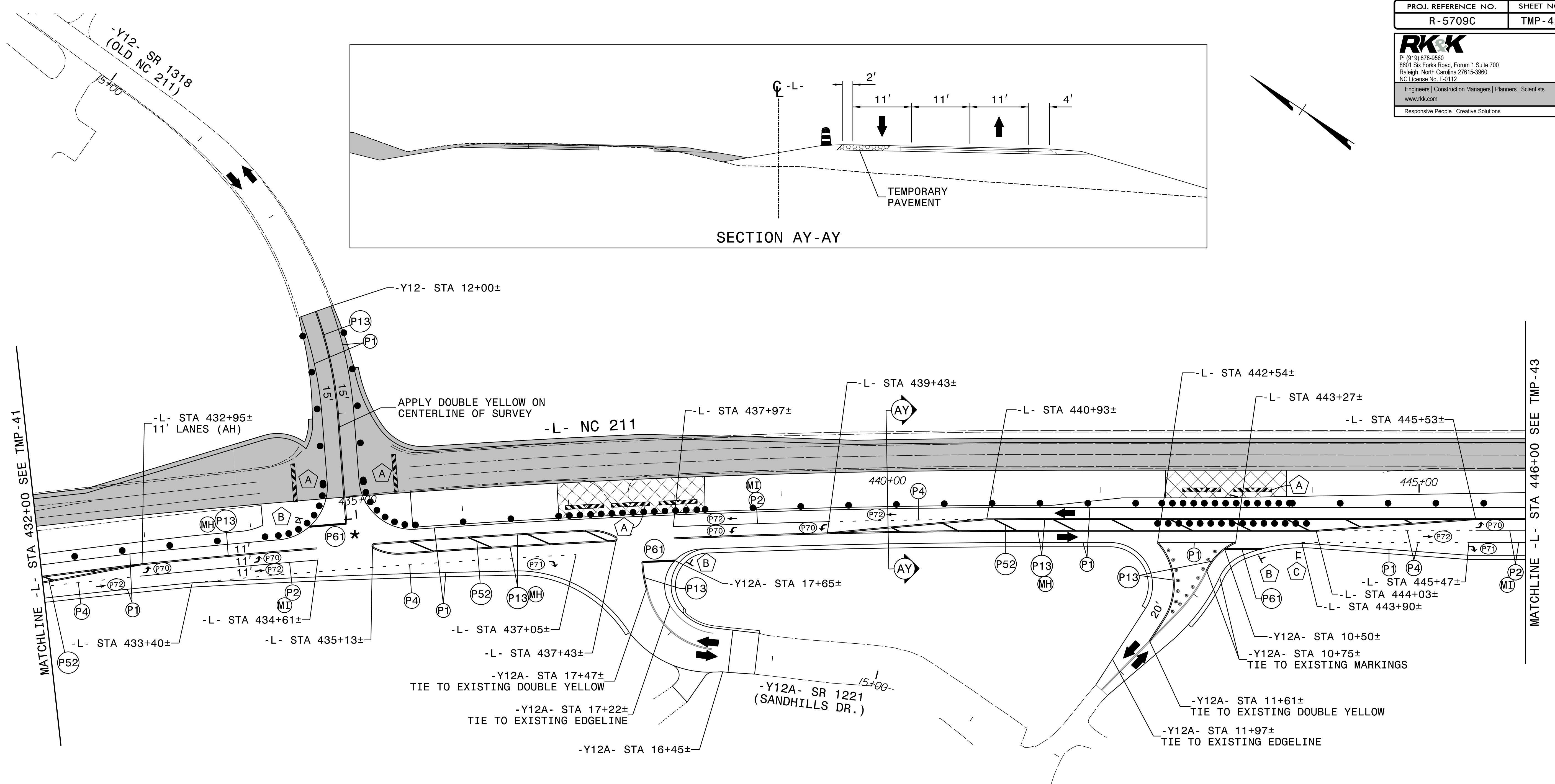
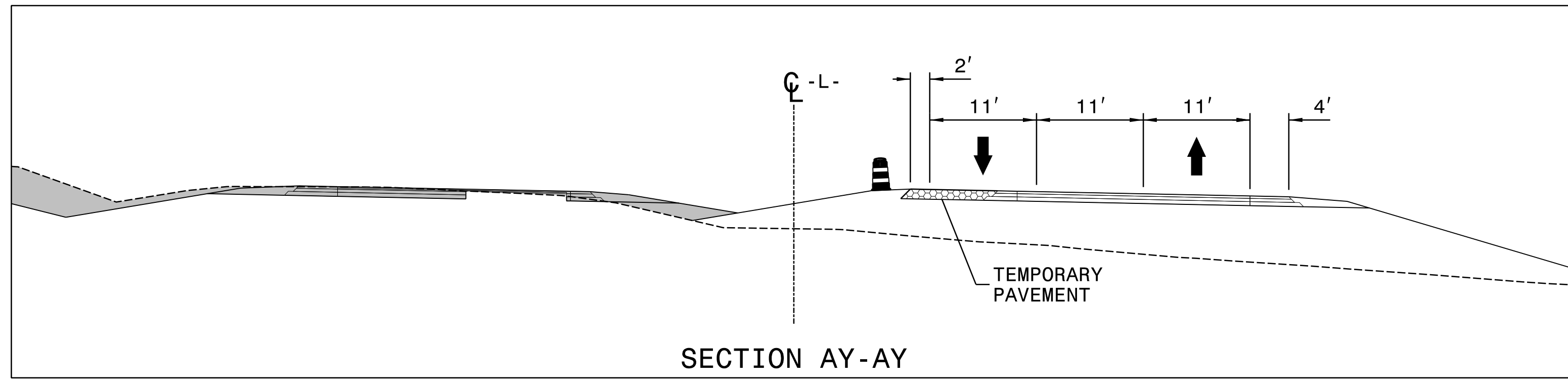

* SET BACK STOP BAR 10' FROM NC 211

APPROVED: Kevin W. Bisby
 DATE: 10/15/2024

SEAL

PHASE II
 STEPS 1 AND 2 DETAILS

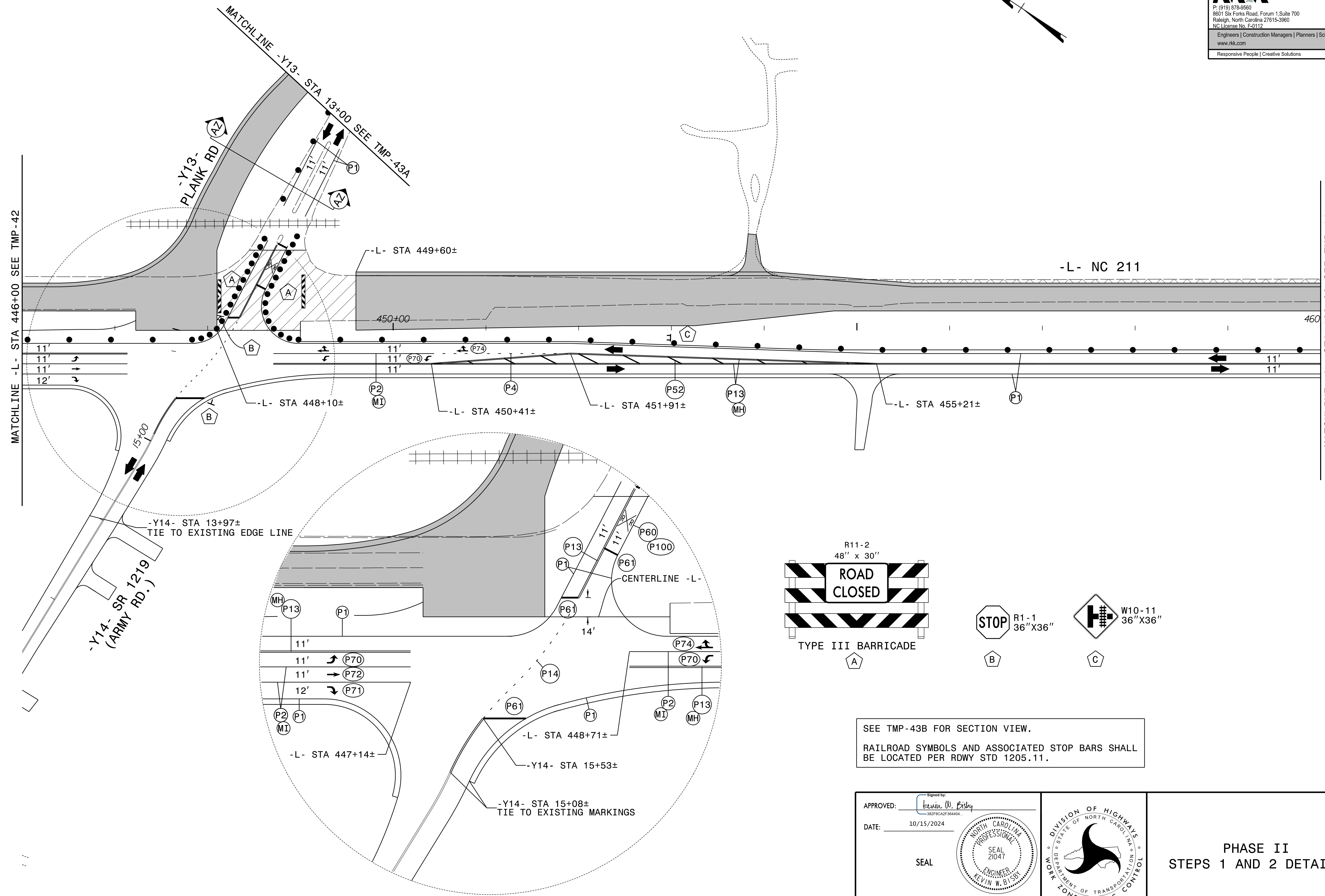

SEE TMP-43B FOR SECTION VIEW.
 RAILROAD SYMBOLS AND ASSOCIATED STOP BARS SHALL BE LOCATED PER RDWY STD 1205.11.

APPROVED: *Kevin W. Eshy*
 382F8CA2F364404
 DATE: 10/15/2024
 SEAL

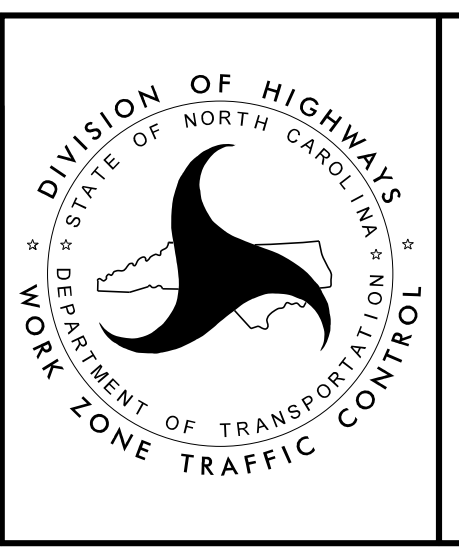

PHASE II
STEPS 1 AND 2 DETAILS

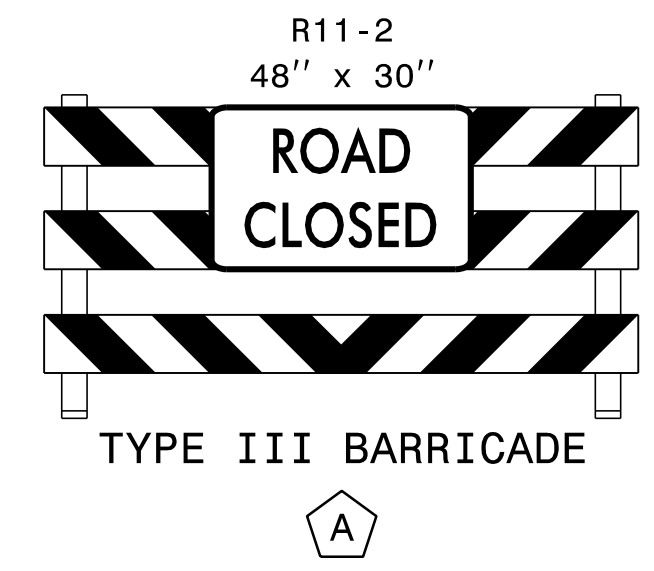
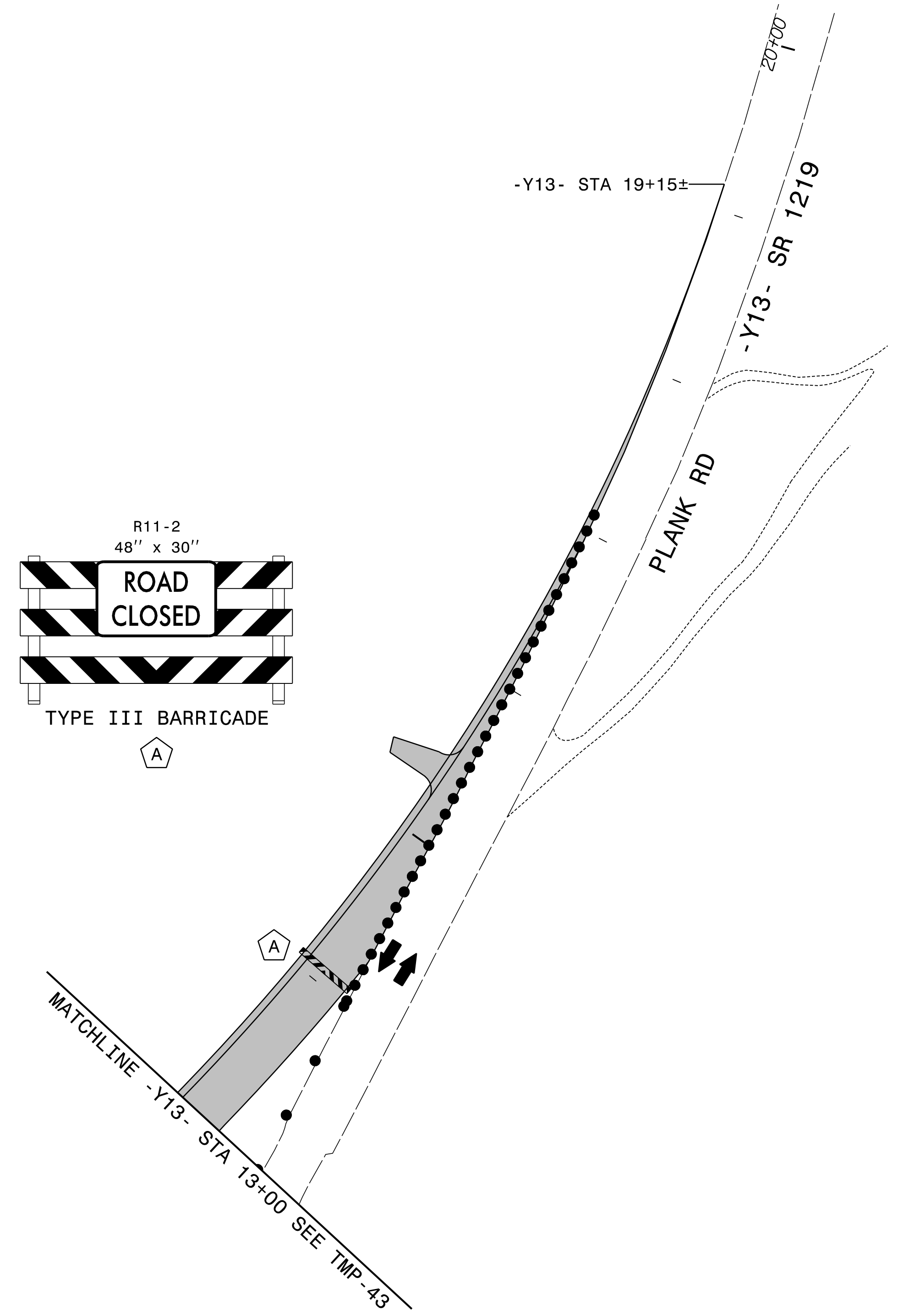
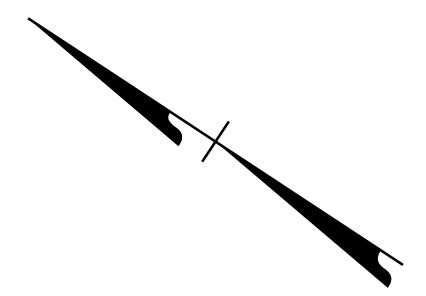

8/28/2024
 RST05_TMP_ipsht43A.dgn
 RStebby

APPROVED: Kevin W. Bisby
Signed by: 382F8CA2F384404

DATE: 10/15/2024

SEAL

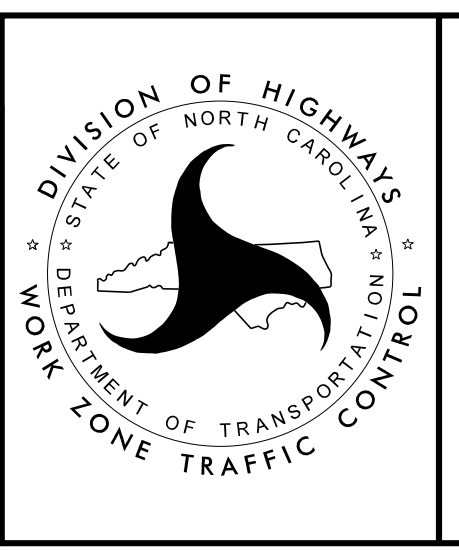

PHASE II
STEP 2 DETAIL

**DOCUMENT NOT CONSIDERED FINAL
 UNLESS ALL SIGNATURES COMPLETED**

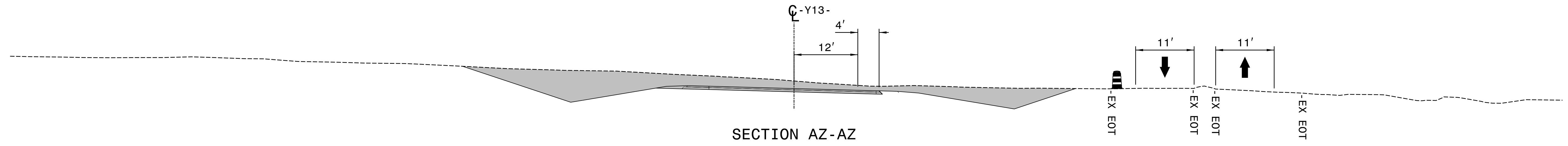

SECTION AZ-AZ

8/28/2024
 RST05_TMP_psh43B.dgn
 RStebby

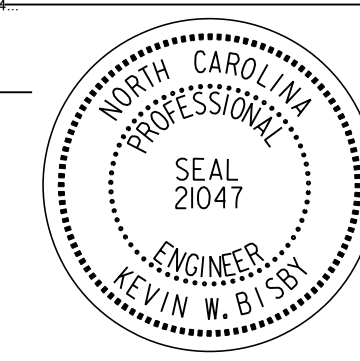
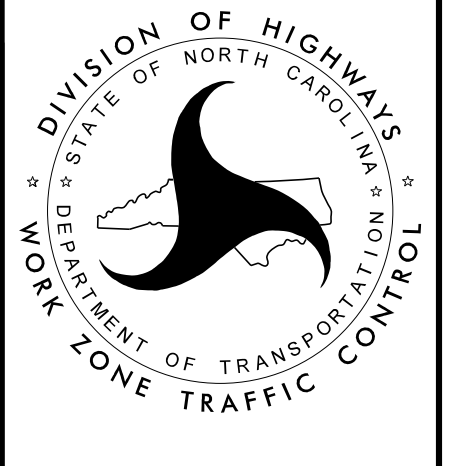
<p>APPROVED: <u>Kevin W. Bisby</u> DATE: 10/15/2024</p> <p>SEAL</p> 		<p>PHASE II STEP 2 DETAIL</p>
<p>DOCUMENT NOT CONSIDERED FINAL UNLESS ALL SIGNATURES COMPLETED</p>		

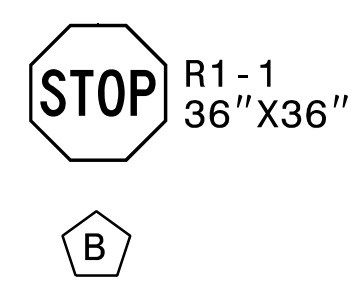
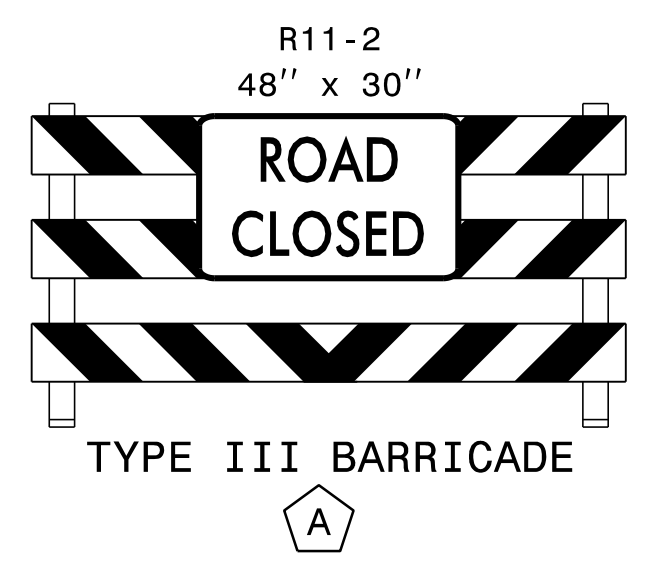
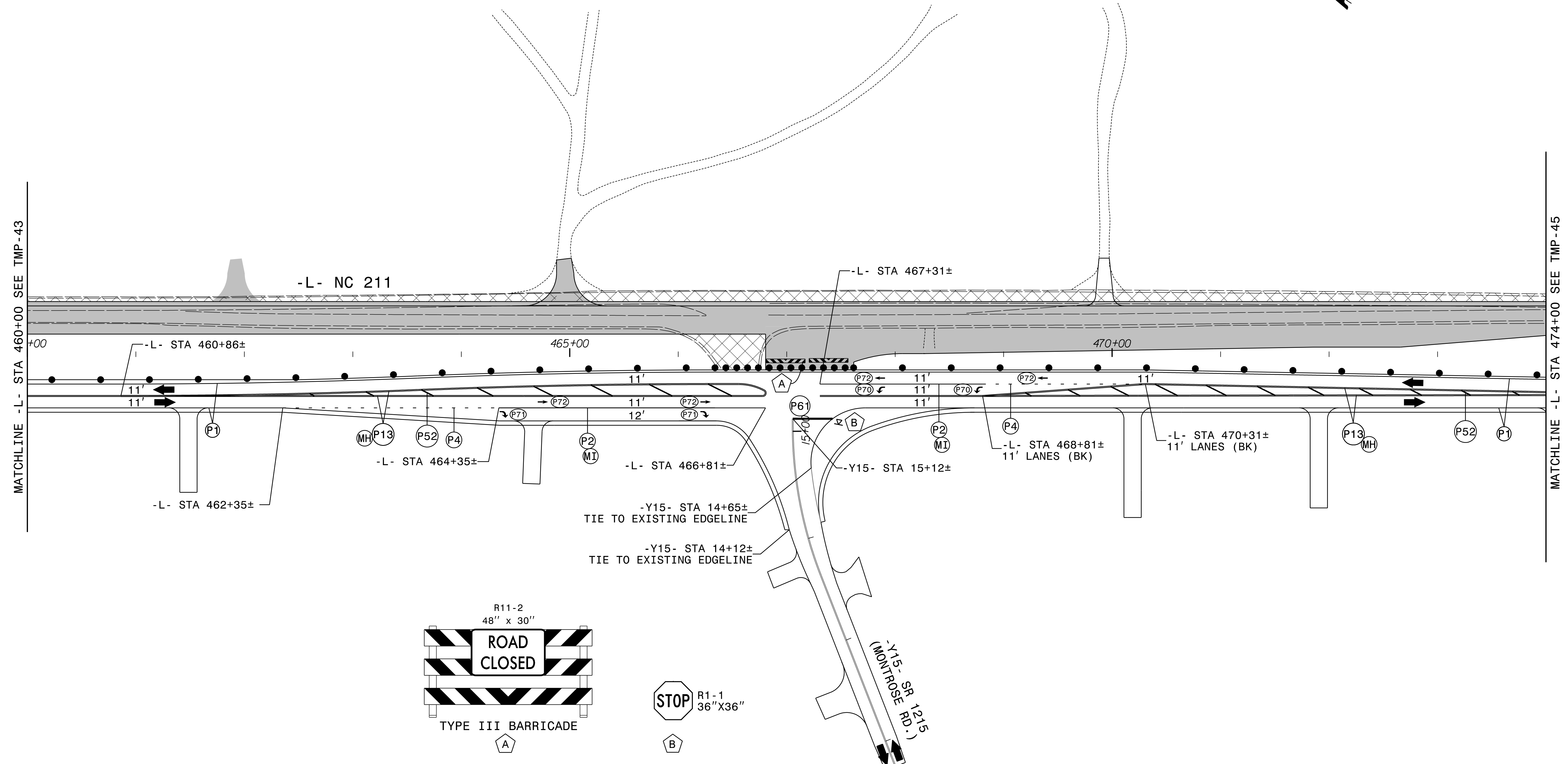
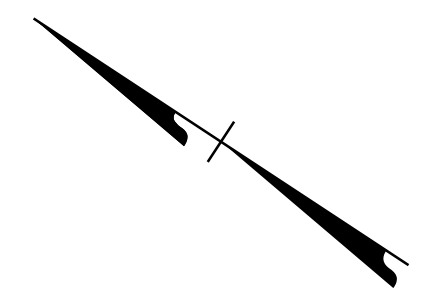

8/28/2024
 RST05_TMP_psh44.dgn
 Robby

APPROVED: Kevin W. Bisby
 DATE: 10/15/2024
 SEAL
 NORTH CAROLINA PROFESSIONAL ENGINEER
 SEAL 21047
 KEVIN W. BISBY

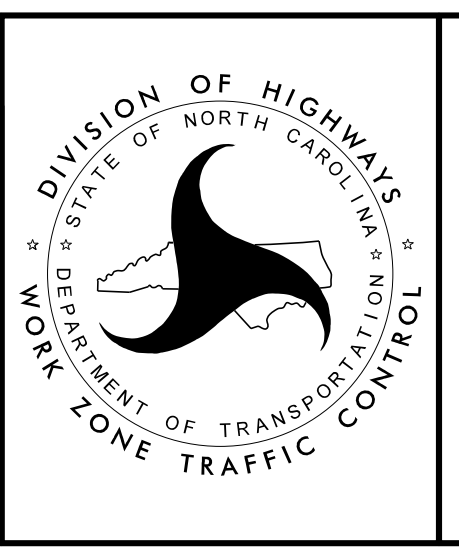

PHASE II
STEPS 1 AND 2 DETAILS

**DOCUMENT NOT CONSIDERED FINAL
 UNLESS ALL SIGNATURES COMPLETED**

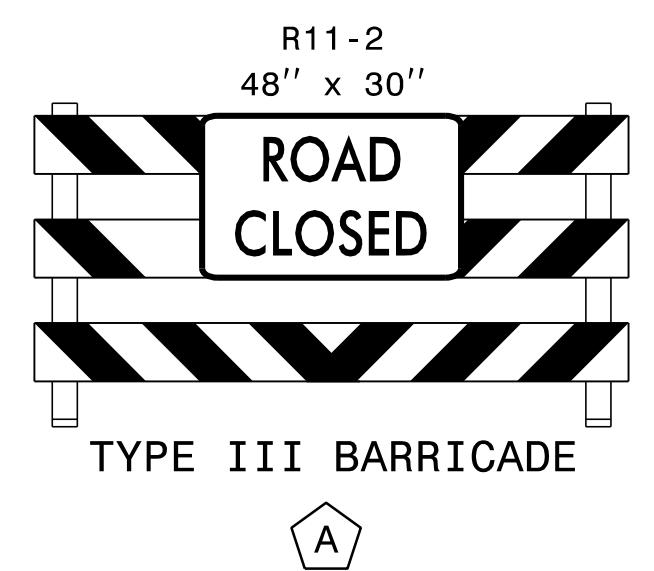
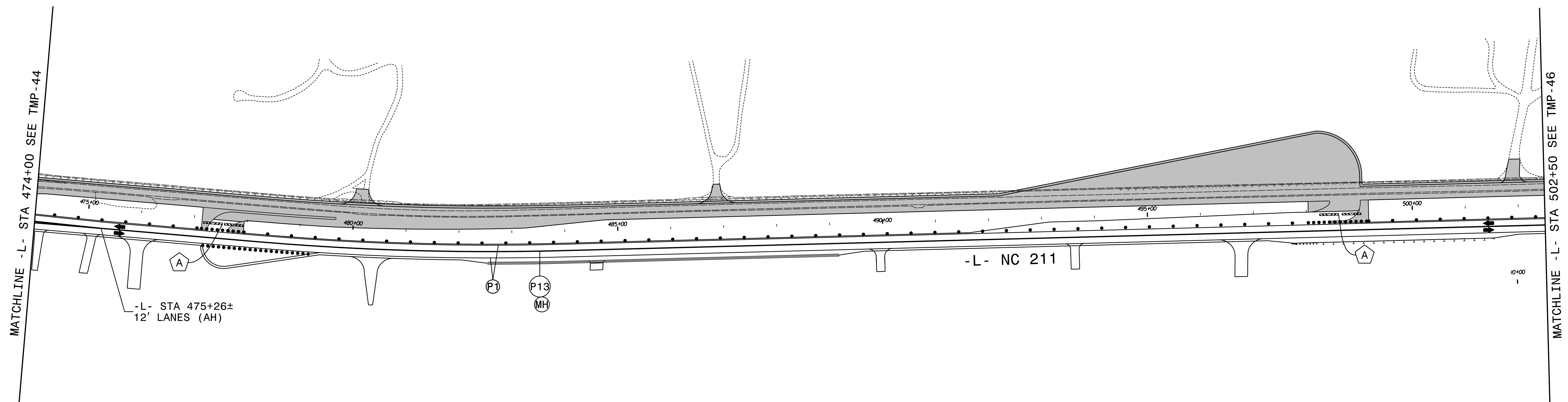
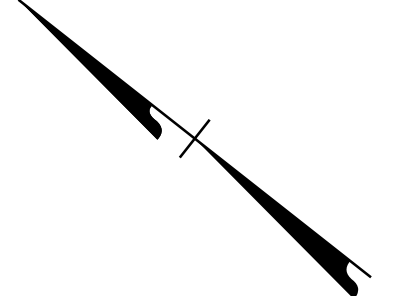

12' LANES UNLESS OTHERWISE INDICATED

APPROVED: *Kevin W. Bisby*
38278CA2F384404

DATE: 10/15/2024

SEAL

**DOCUMENT NOT CONSIDERED FINAL
UNLESS ALL SIGNATURES COMPLETED**

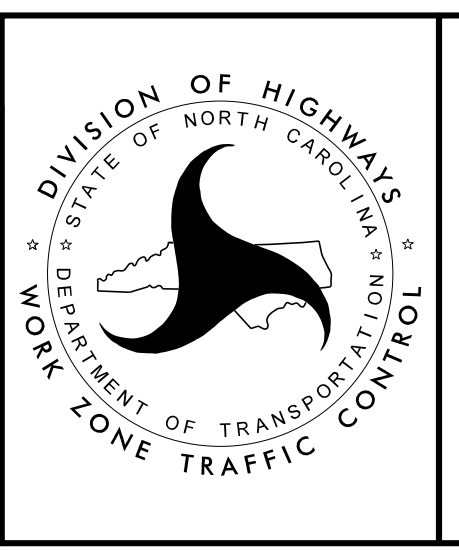

PHASE II
STEPS 1 AND 2 DETAILS

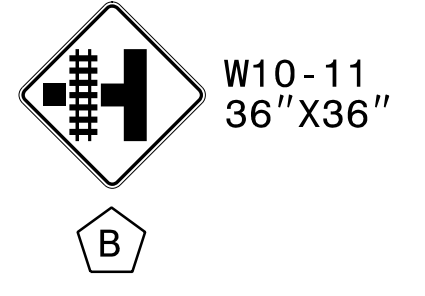
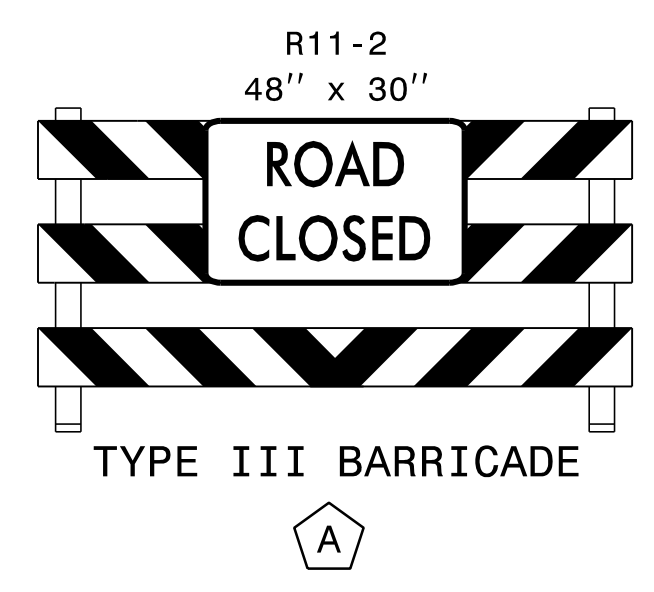
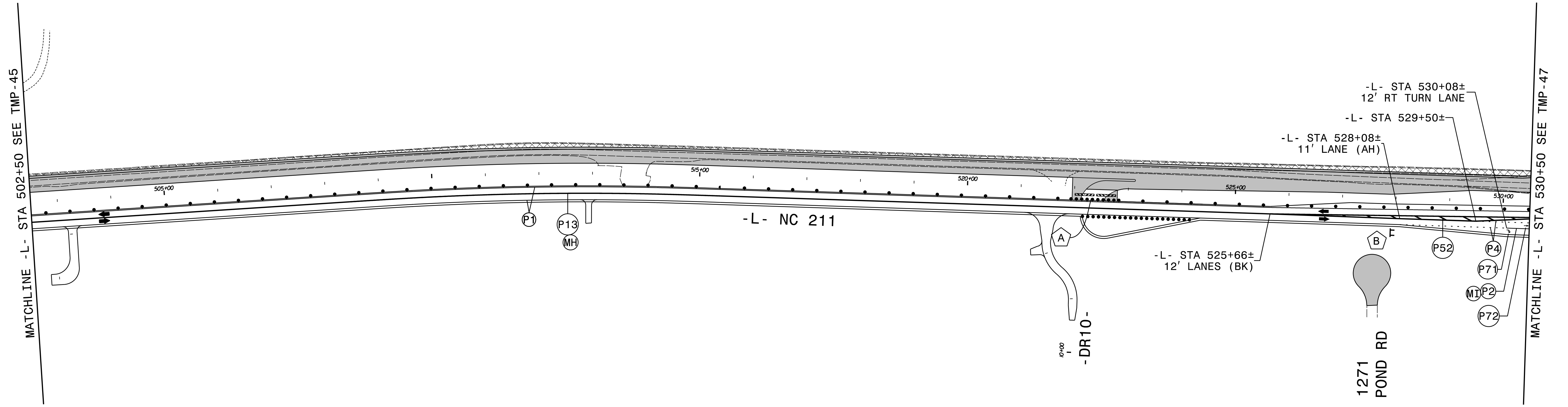
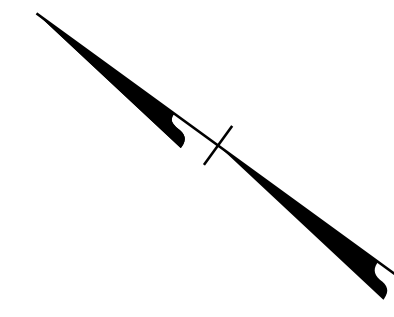

12' LANES UNLESS OTHERWISE INDICATED.

8/28/2024
 RST05_TMP_psh46.dgn
 Rstebby

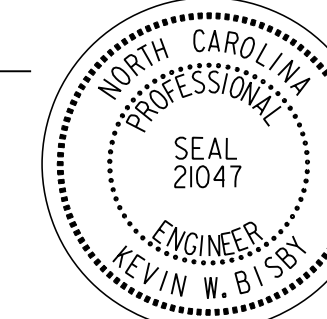
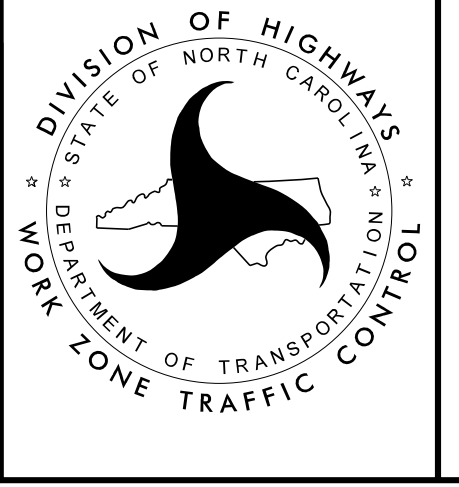
APPROVED: <i>Kevin W. Bisby</i> DATE: 10/15/2024 SEAL 		<p>PHASE II STEPS 1 AND 2 DETAILS</p>
<p>DOCUMENT NOT CONSIDERED FINAL UNLESS ALL SIGNATURES COMPLETED</p>		

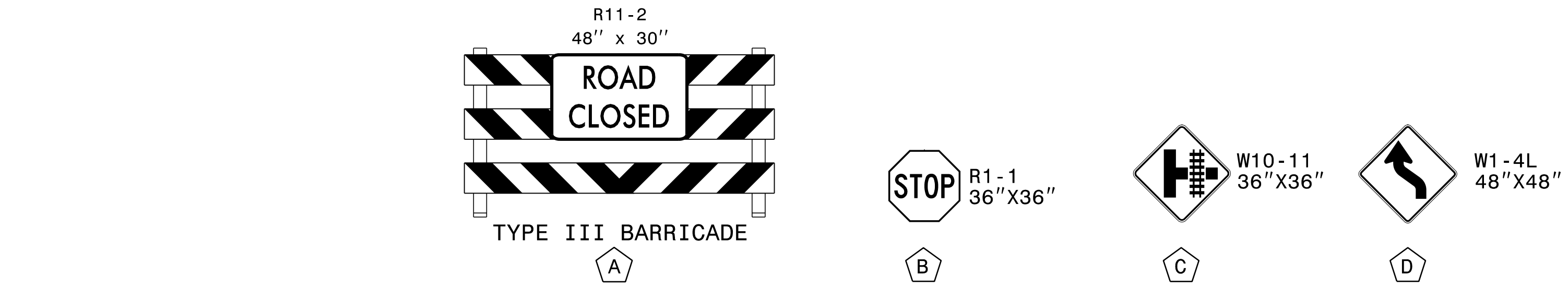
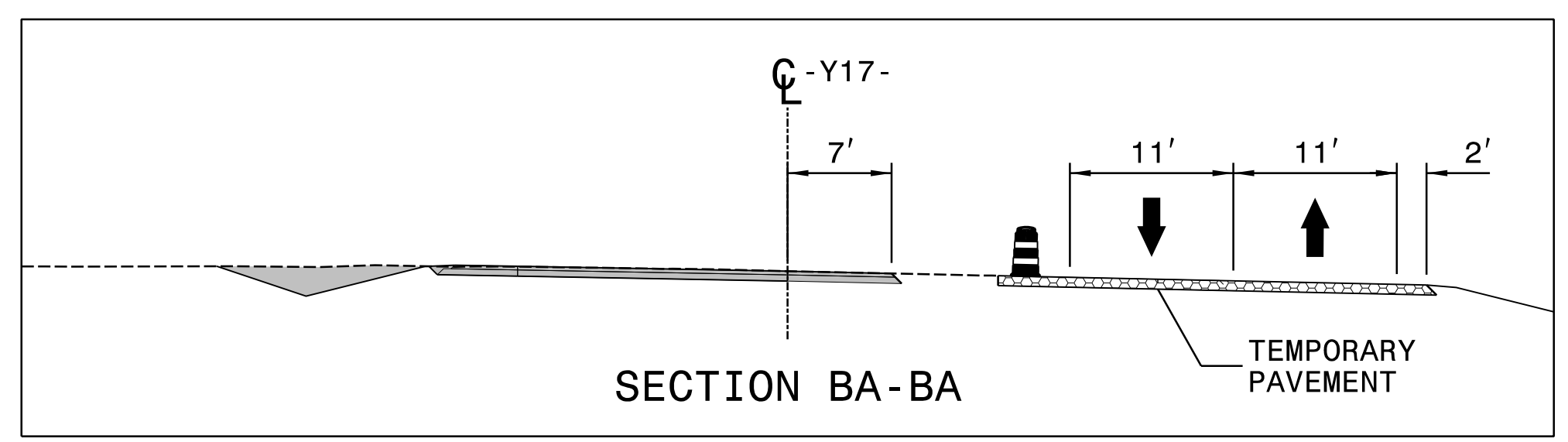
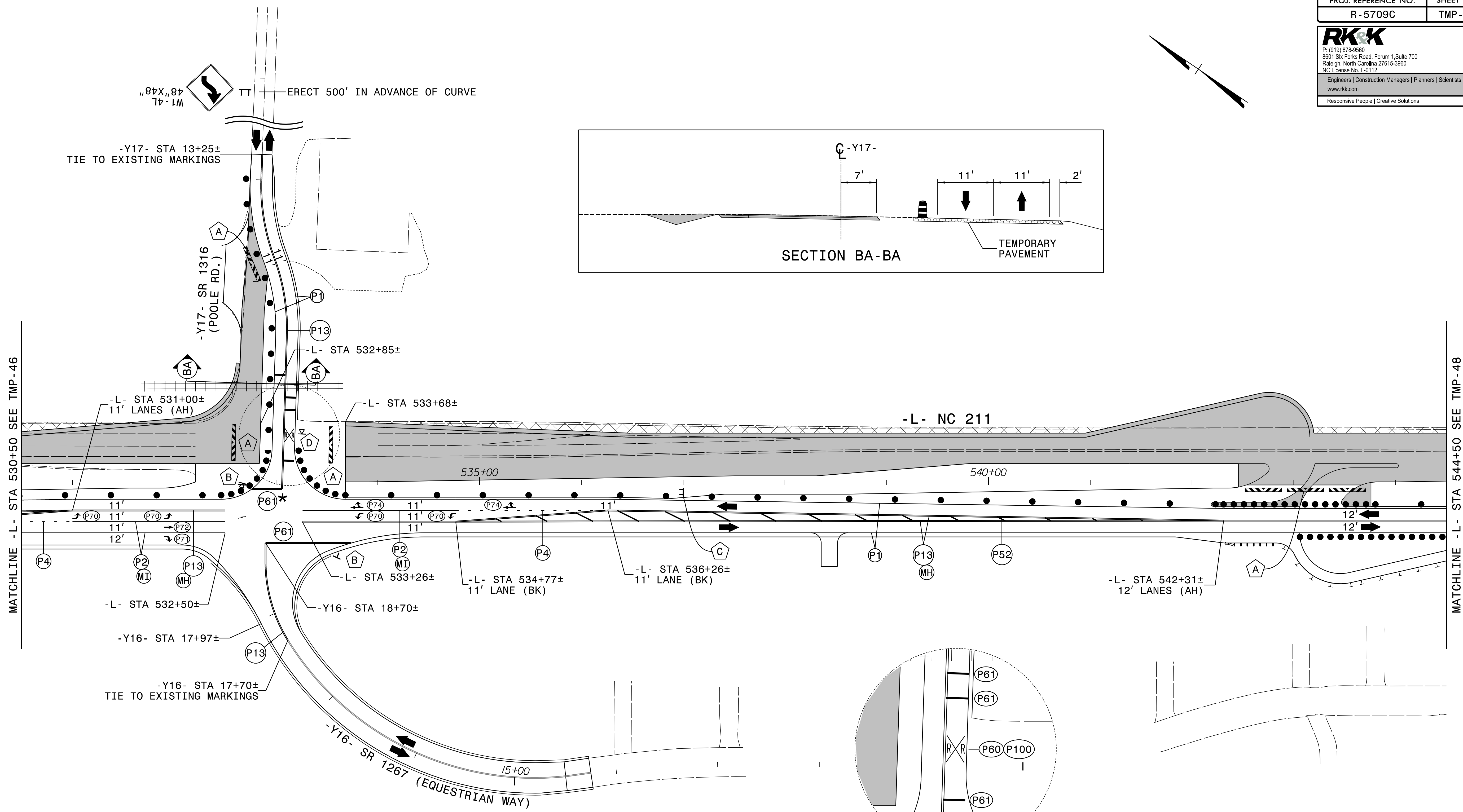
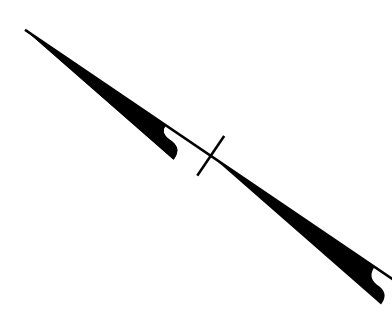

* SET BACK STOP BAR 10' FROM NC 211.
 RAILROAD SYMBOLS AND ASSOCIATED STOP BARS SHALL BE LOCATED PER RDWY STD 1205.11.

APPROVED: Kevin W. Bisby
 DATE: 10/15/2024
 SEAL

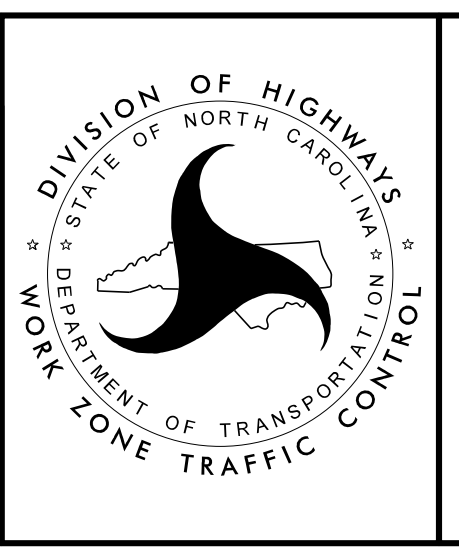

PHASE II
 STEPS 1 AND 2 DETAILS

8/28/2024
 RST05_TMP_psh47.dgn
 R05bby

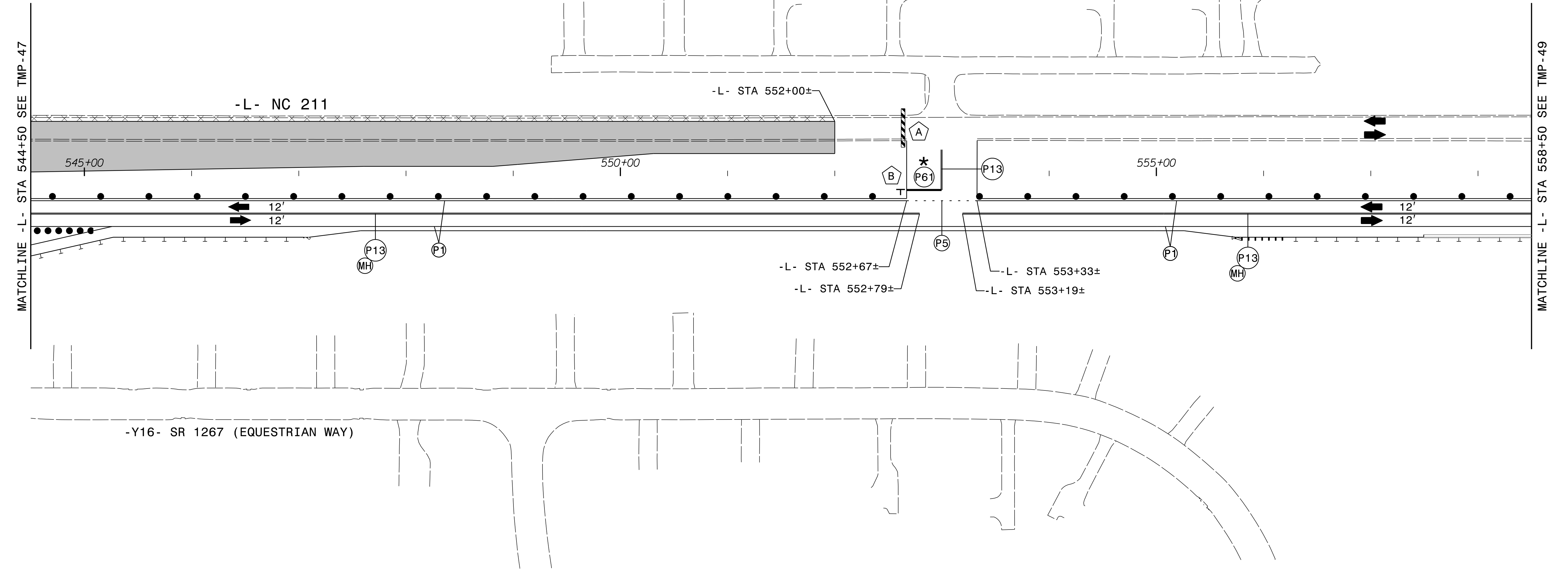
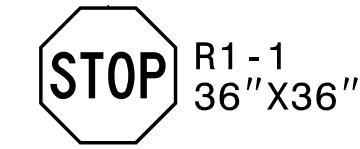
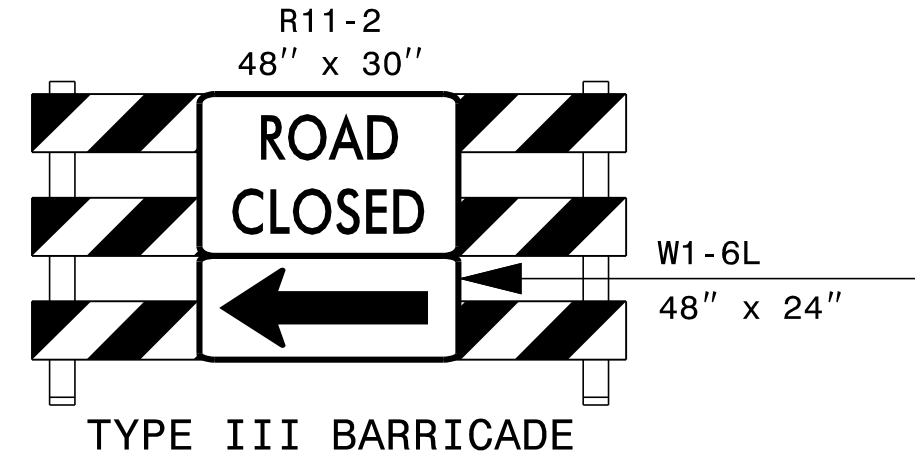
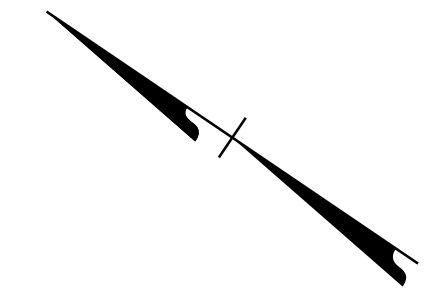

8/28/2024
 RST05_TMP_psh48.dgn
 Robby

* SET BACK STOP BAR 10' FROM NC 211.

APPROVED: Kevin W. Bisby
382PBCA2F304404

DATE: 10/15/2024

SEAL

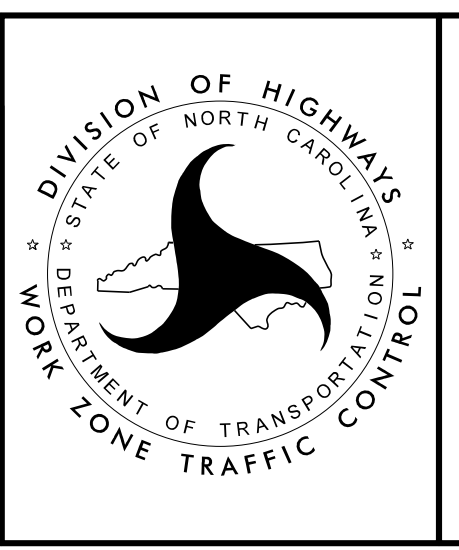

PHASE II
STEPS 1 AND 2 DETAILS

**DOCUMENT NOT CONSIDERED FINAL
 UNLESS ALL SIGNATURES COMPLETED**

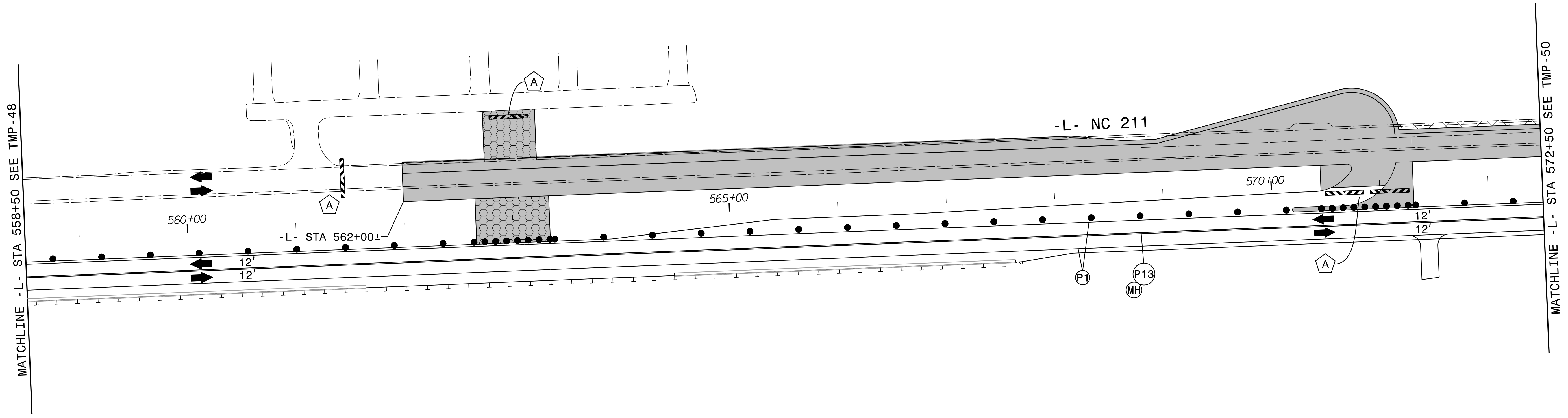
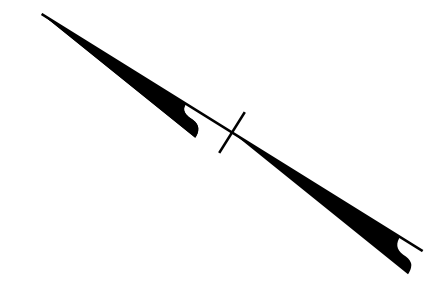
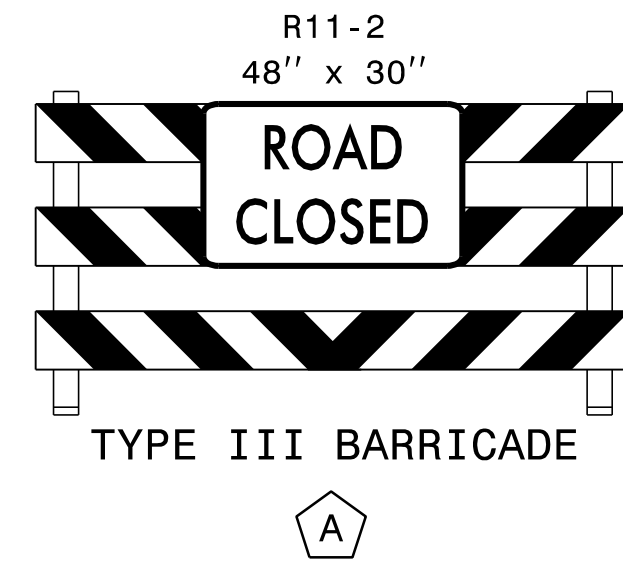

8/28/2024
 RST05_TMP_psh49.dgn
 Rolsby

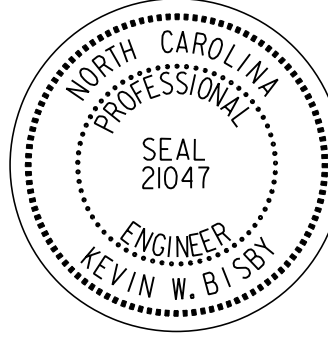
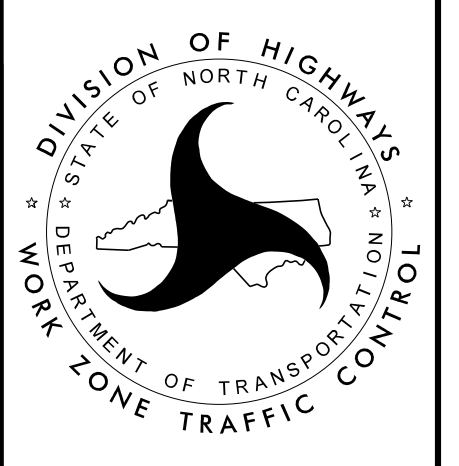
APPROVED: <u>Kevin W. Bisby</u> DATE: 10/15/2024 SEAL 		<p>PHASE II STEPS 1 AND 2 DETAILS</p>
<p>DOCUMENT NOT CONSIDERED FINAL UNLESS ALL SIGNATURES COMPLETED</p>		

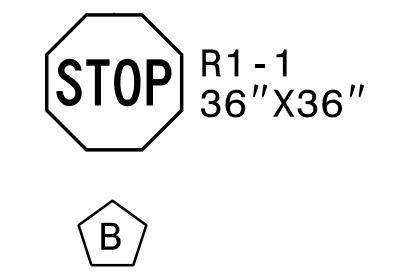
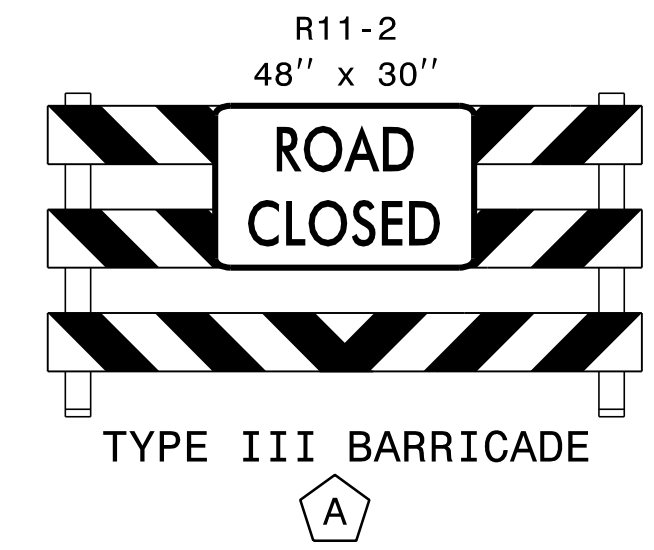
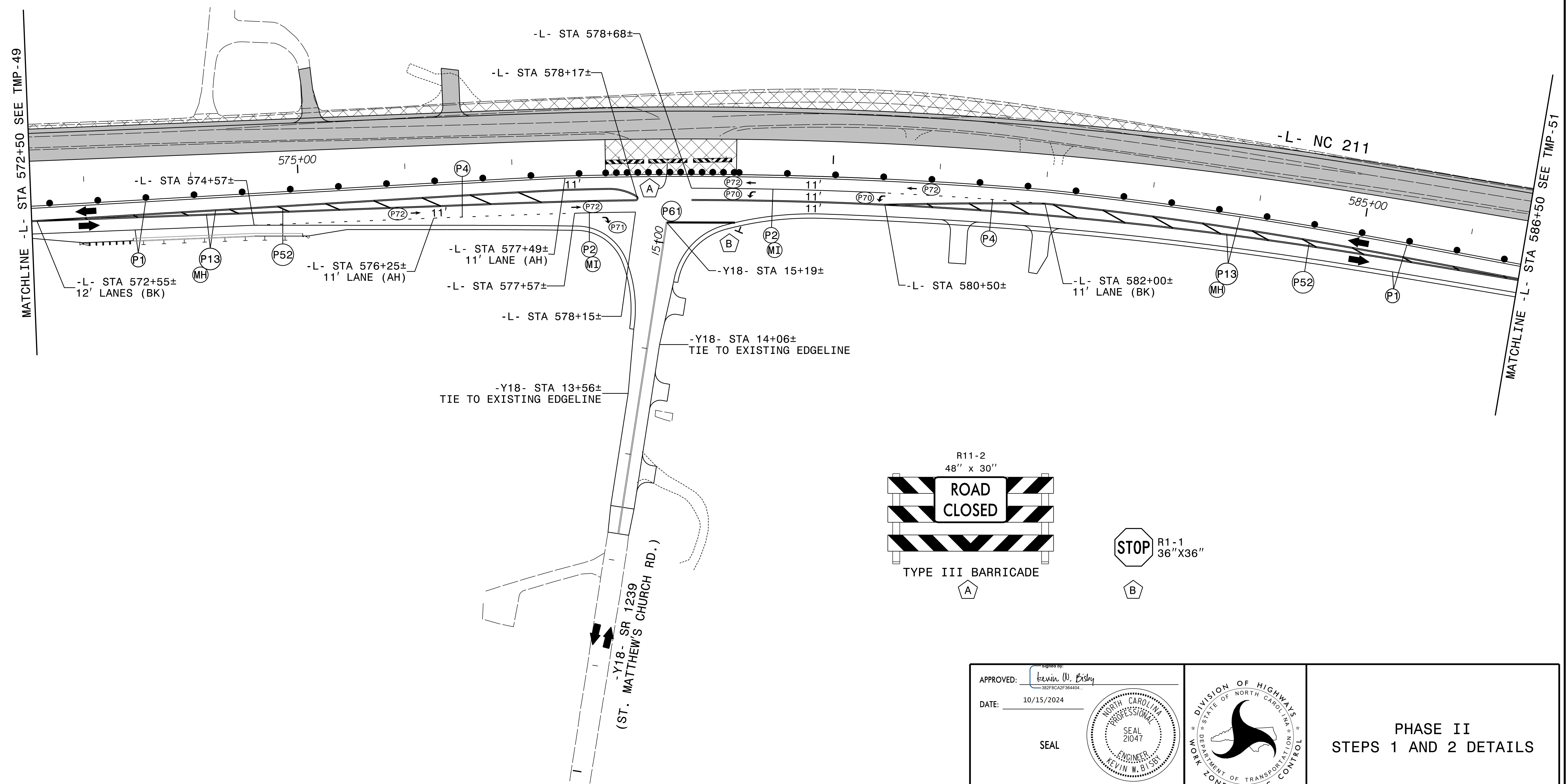
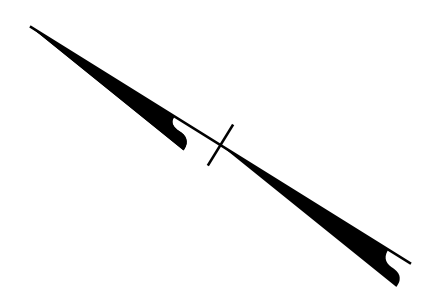

8/28/2024
 RST05_TMP-psht50.dgn
 Rolsby

APPROVED: Kevin W. Bisby
382F8CAGF364404...

DATE: 10/15/2024

SEAL

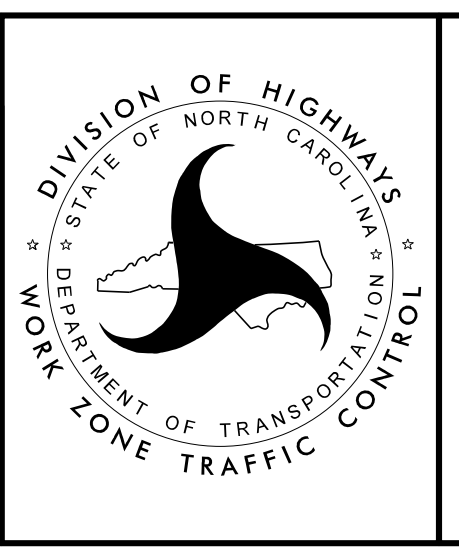

PHASE II
STEPS 1 AND 2 DETAILS

**DOCUMENT NOT CONSIDERED FINAL
 UNLESS ALL SIGNATURES COMPLETED**

PROJ. REFERENCE NO.	SHEET NO.
R-5709C	TMP-51

RKK
 P: (919) 878-8560
 8601 Six Forks Road, Forum 1, Suite 700
 Raleigh, North Carolina 27615-3960
 NC License No. F-0112
 Engineers | Construction Managers | Planners | Scientists
 www.rkk.com
 Responsive People | Creative Solutions

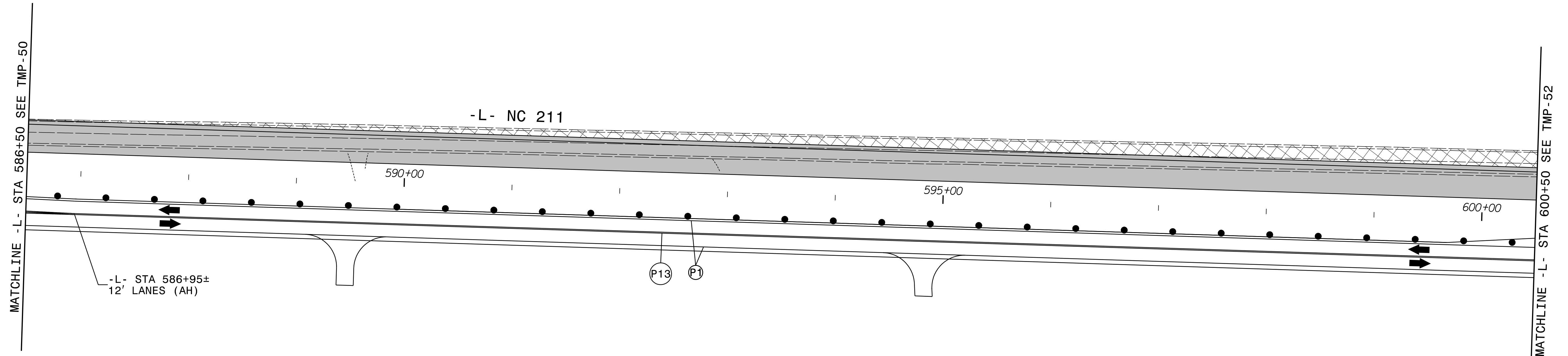
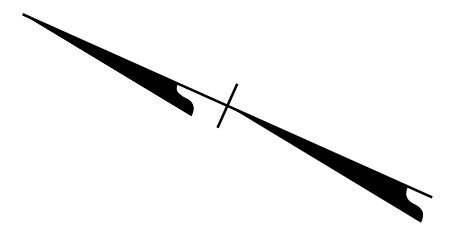

8/28/2024
 RST05_TMP_psh51.dgn
 RStebby

APPROVED: *Kevin W. Bisby*
182P8CA2P384404

DATE: 10/15/2024

SEAL

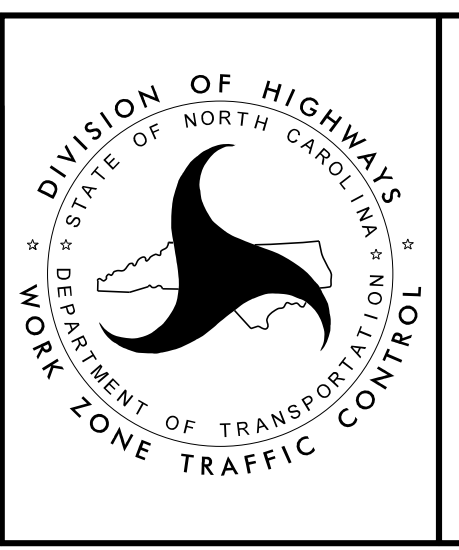

PHASE II
STEPS 1 AND 2 DETAILS

**DOCUMENT NOT CONSIDERED FINAL
 UNLESS ALL SIGNATURES COMPLETED**

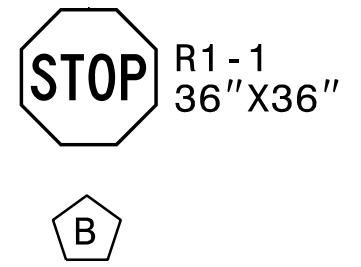
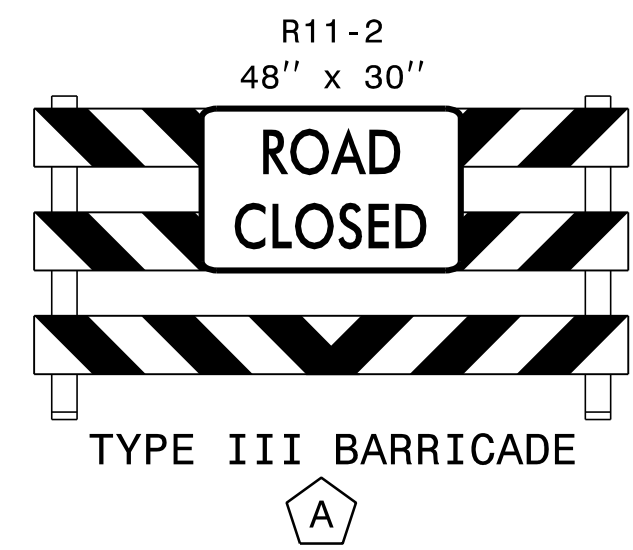
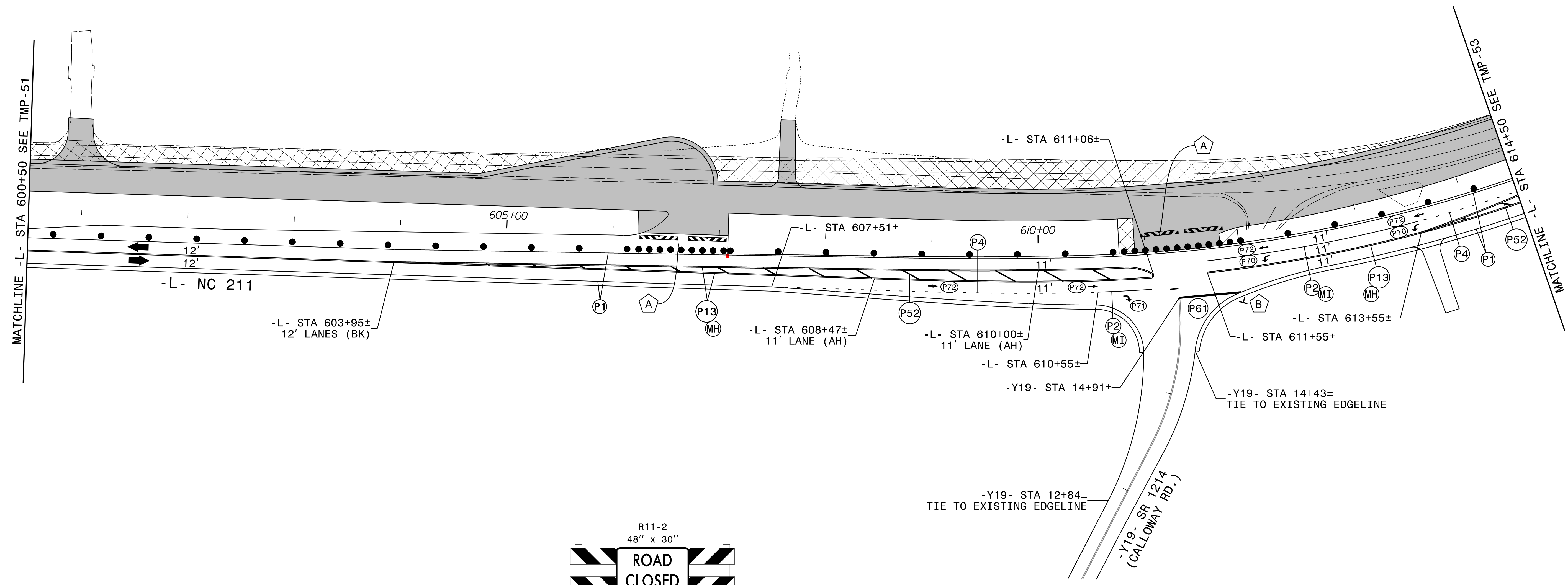

APPROVED: *Kevin W. Bisby*
18298CA2P364404

DATE: 10/15/2024

SEAL

**DOCUMENT NOT CONSIDERED FINAL
UNLESS ALL SIGNATURES COMPLETED**

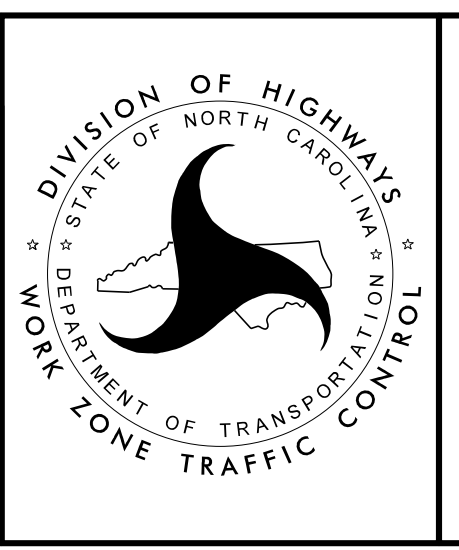

PHASE II
STEPS 1 AND 2 DETAILS

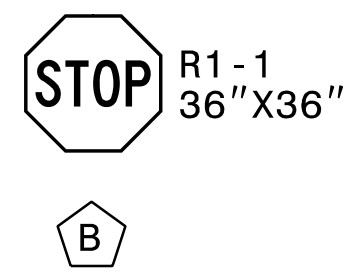
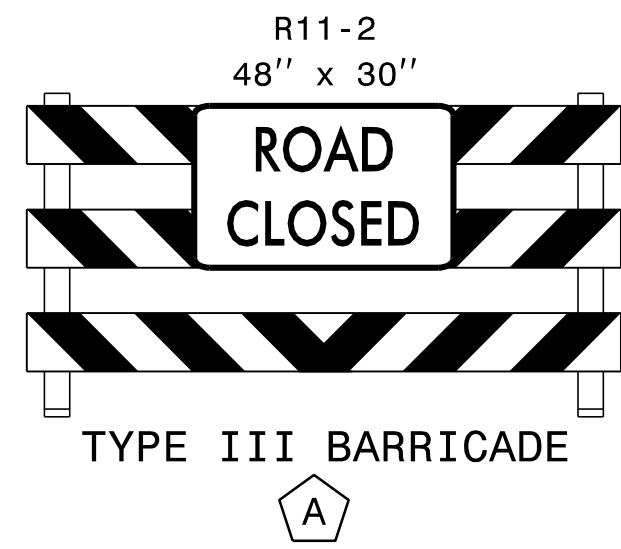
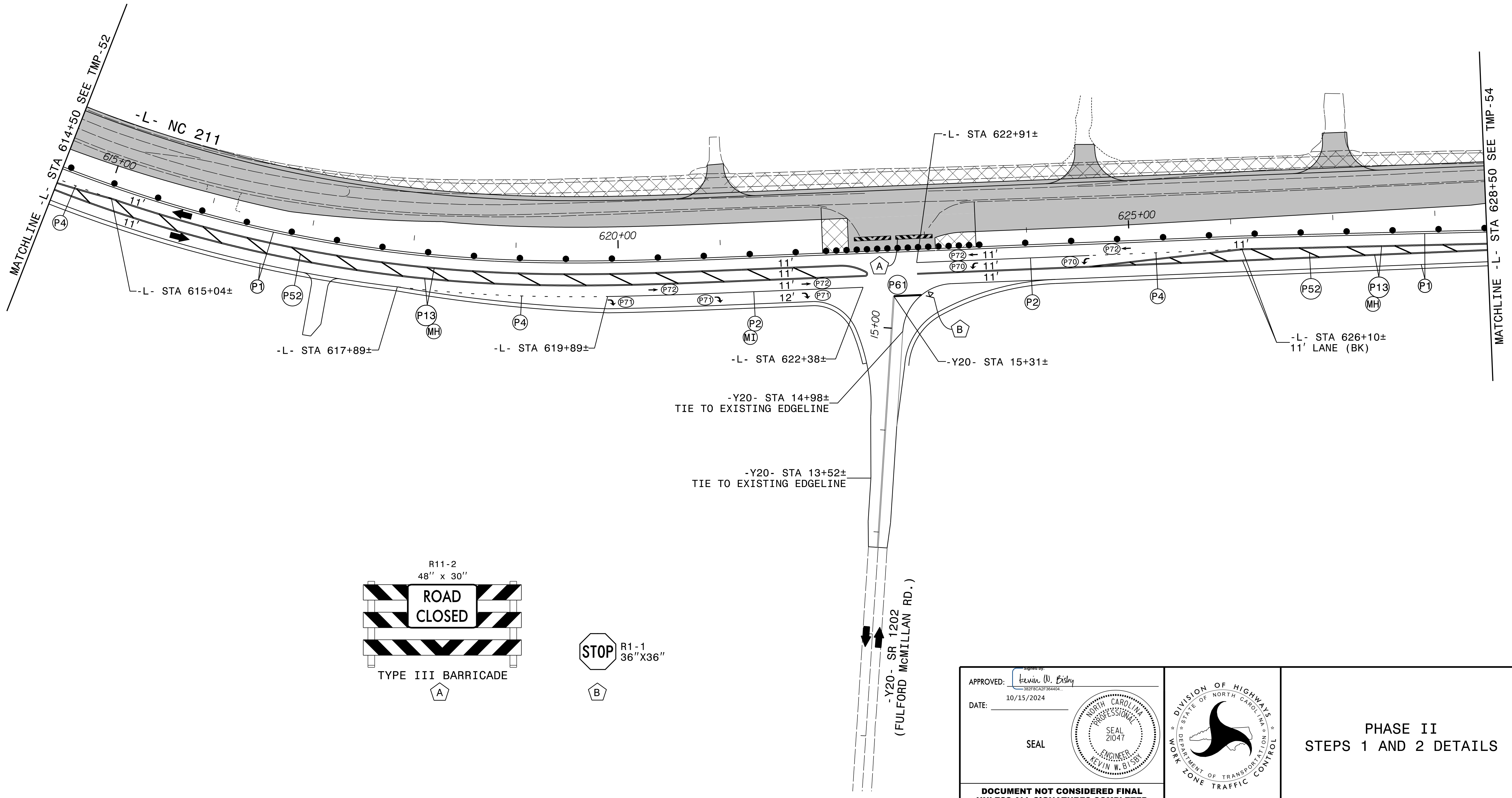
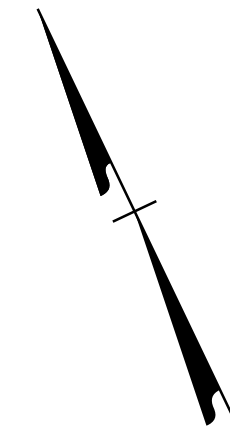

APPROVED: Kevin W. Bisby
18298CA2P364404
 DATE: 10/15/2024

SEAL

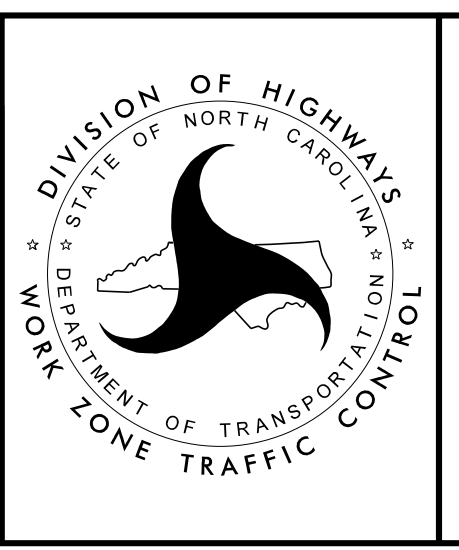

PHASE II
 STEPS 1 AND 2 DETAILS

8/28/2024
 RST05_TMP_psh53.dgn
 Rolsby

DOCUMENT NOT CONSIDERED FINAL
 UNLESS ALL SIGNATURES COMPLETED

PROJ. REFERENCE NO.	SHEET NO.
R-5709C	TMP-54

RKK
 P: (919) 878-8560
 8601 Six Forks Road, Forum 1, Suite 700
 Raleigh, North Carolina 27615-3960
 NC License No. F-0112
 Engineers | Construction Managers | Planners | Scientists
 www.rkk.com
 Responsive People | Creative Solutions

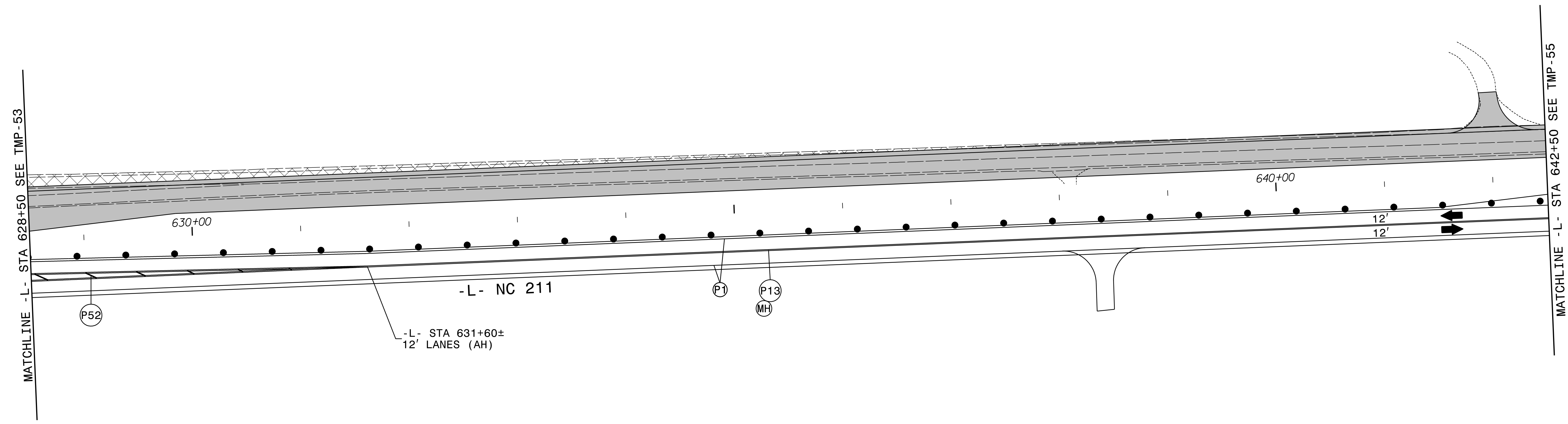
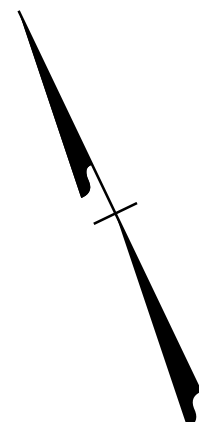

8/28/2024
 RST05_TMP_psh54.dgn
 Rolsby

APPROVED: *Kevin W. Bisby*
18298CA2P384404

DATE: 10/15/2024

SEAL

**DOCUMENT NOT CONSIDERED FINAL
 UNLESS ALL SIGNATURES COMPLETED**

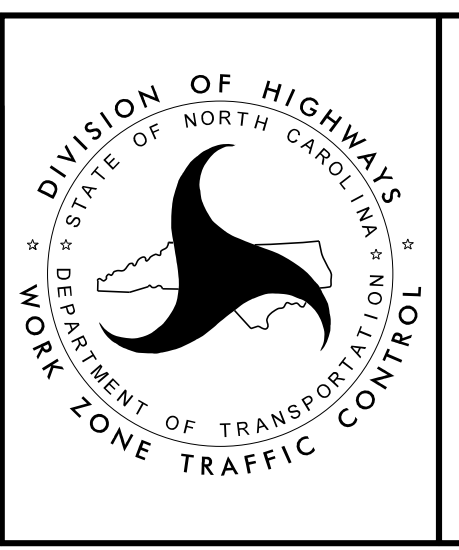

PHASE II
 STEPS 1 AND 2 DETAILS

PROJ. REFERENCE NO.	SHEET NO.
R-5709C	TMP-55

RKK
 P: (919) 878-8560
 8601 Six Forks Road, Forum 1, Suite 700
 Raleigh, North Carolina 27615-3960
 NC License No. F-0112
 Engineers | Construction Managers | Planners | Scientists
 www.rkk.com
 Responsive People | Creative Solutions

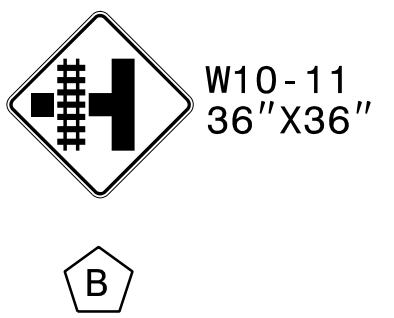
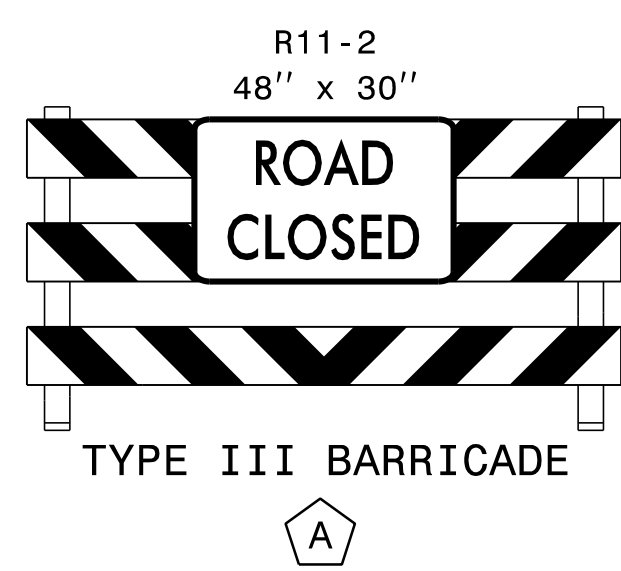
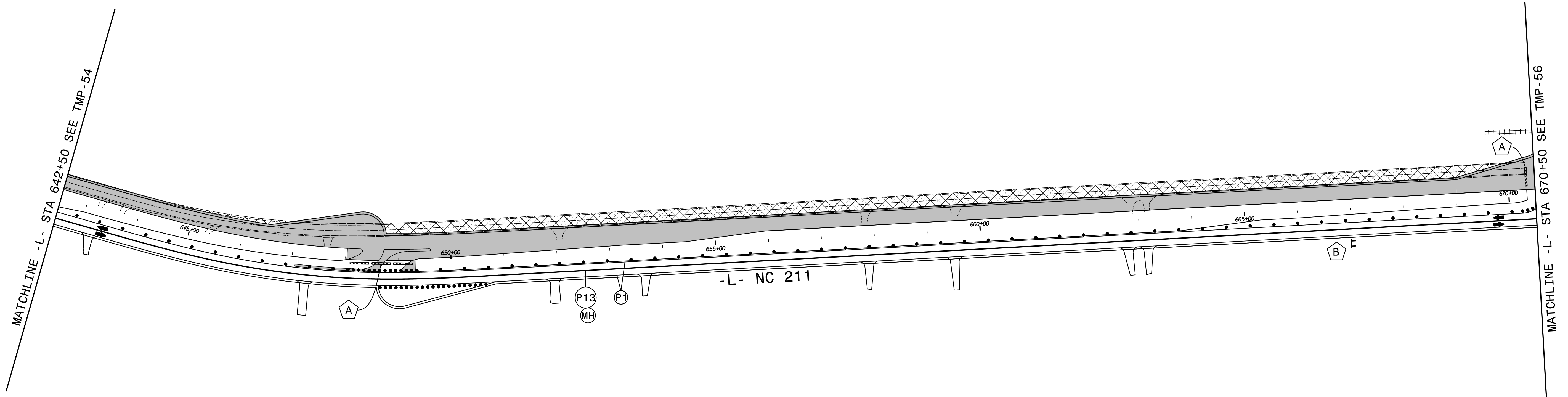

12' LANES

APPROVED: *Kevin W. Bisby*
382P0CA2P364404

DATE: 10/15/2024

SEAL

DOCUMENT NOT CONSIDERED FINAL
UNLESS ALL SIGNATURES COMPLETED

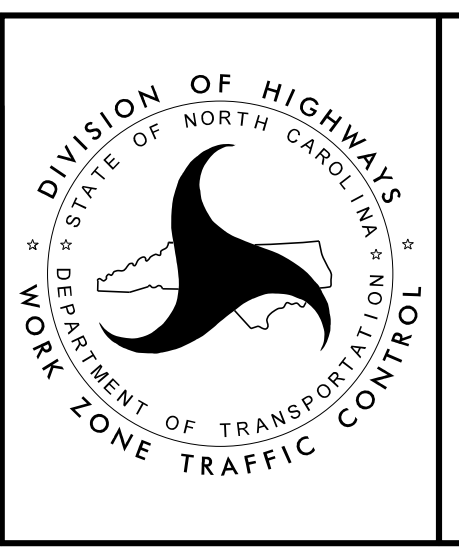

PHASE II
STEPS 1 AND 2 DETAILS

8/28/2024
 RST05_TMP_psh55.dgn
 RStebby

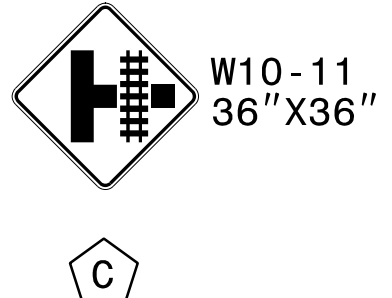
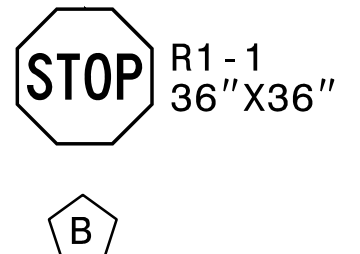
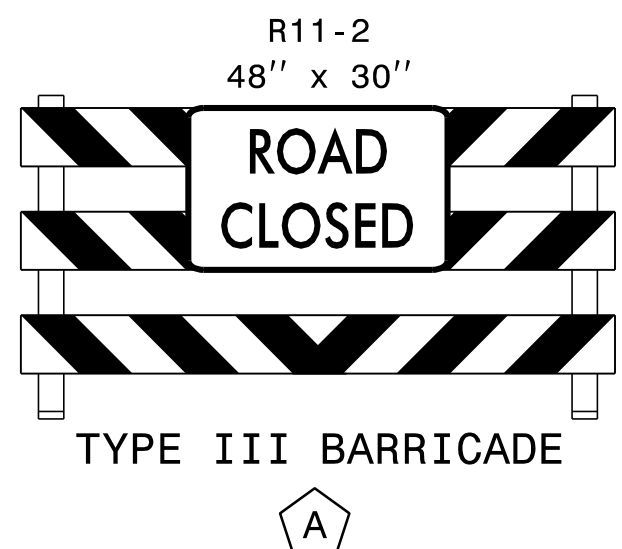
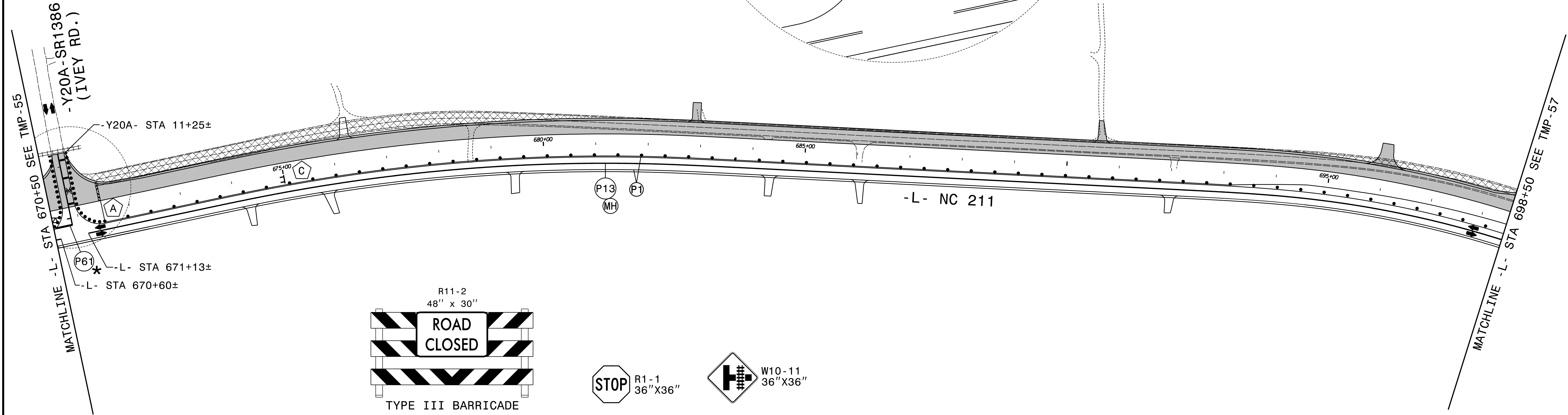
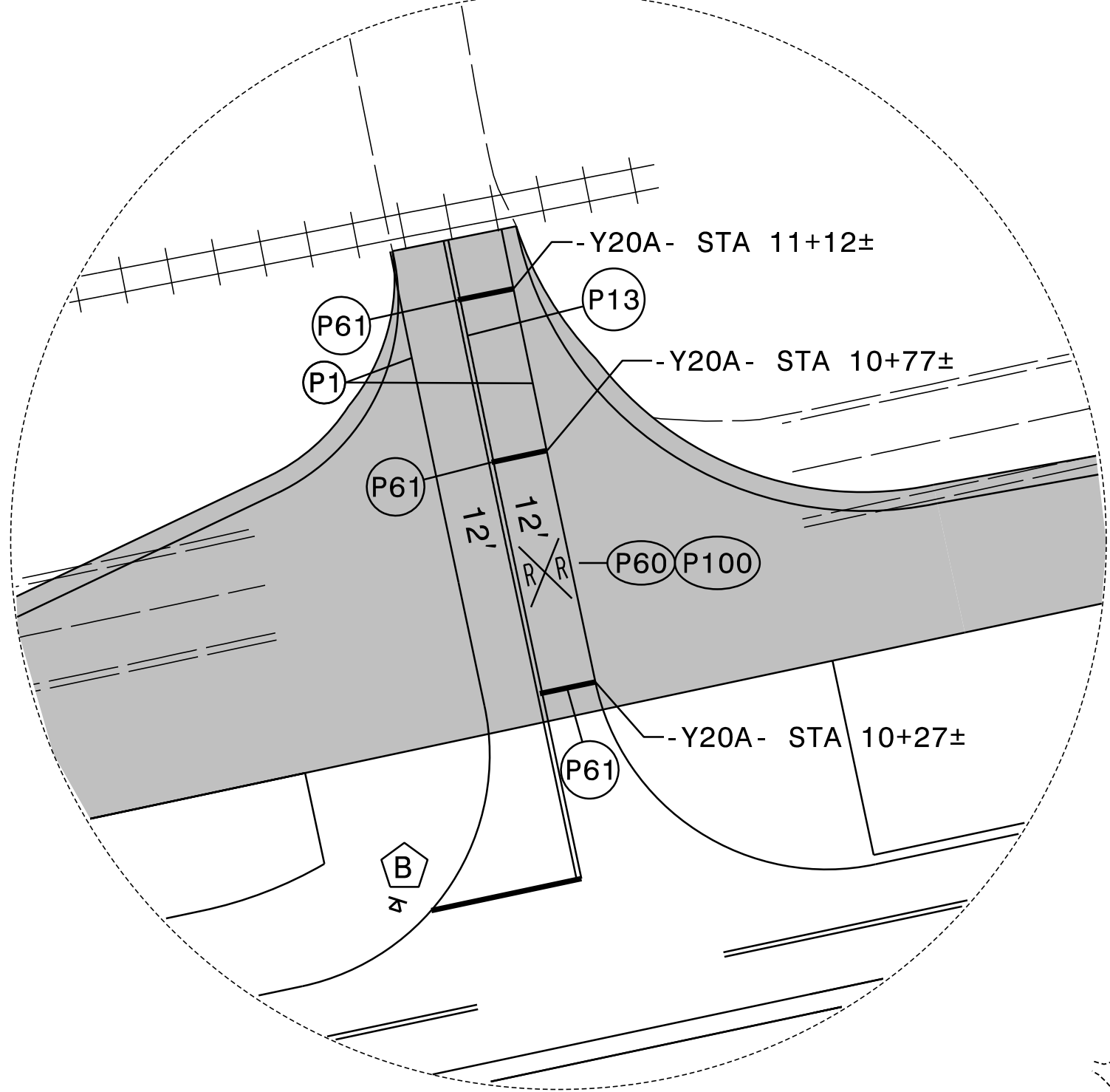
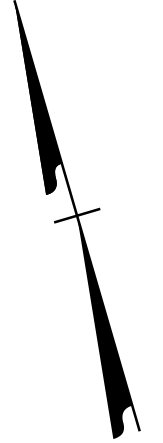

12' LANES
 * SET BACK STOP BAR 10' FROM NC 211
 RAILROAD SYMBOLS AND ASSOCIATED STOP BARS SHALL BE LOCATED PER RDWY STD 1205.11.

APPROVED: Kevin W. Bisby
182P8CA2P364404
 DATE: 10/15/2024

SEAL

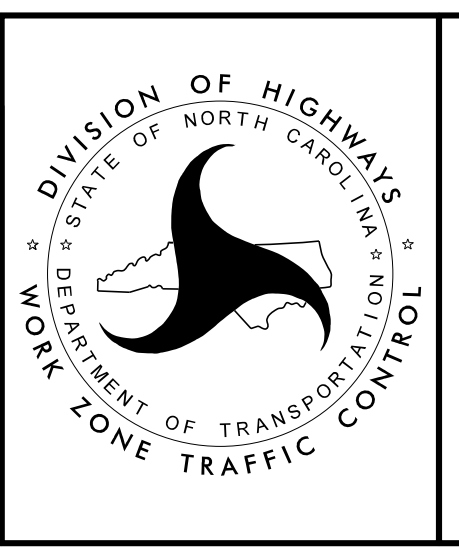

PHASE II
 STEPS 1 AND 2 DETAILS

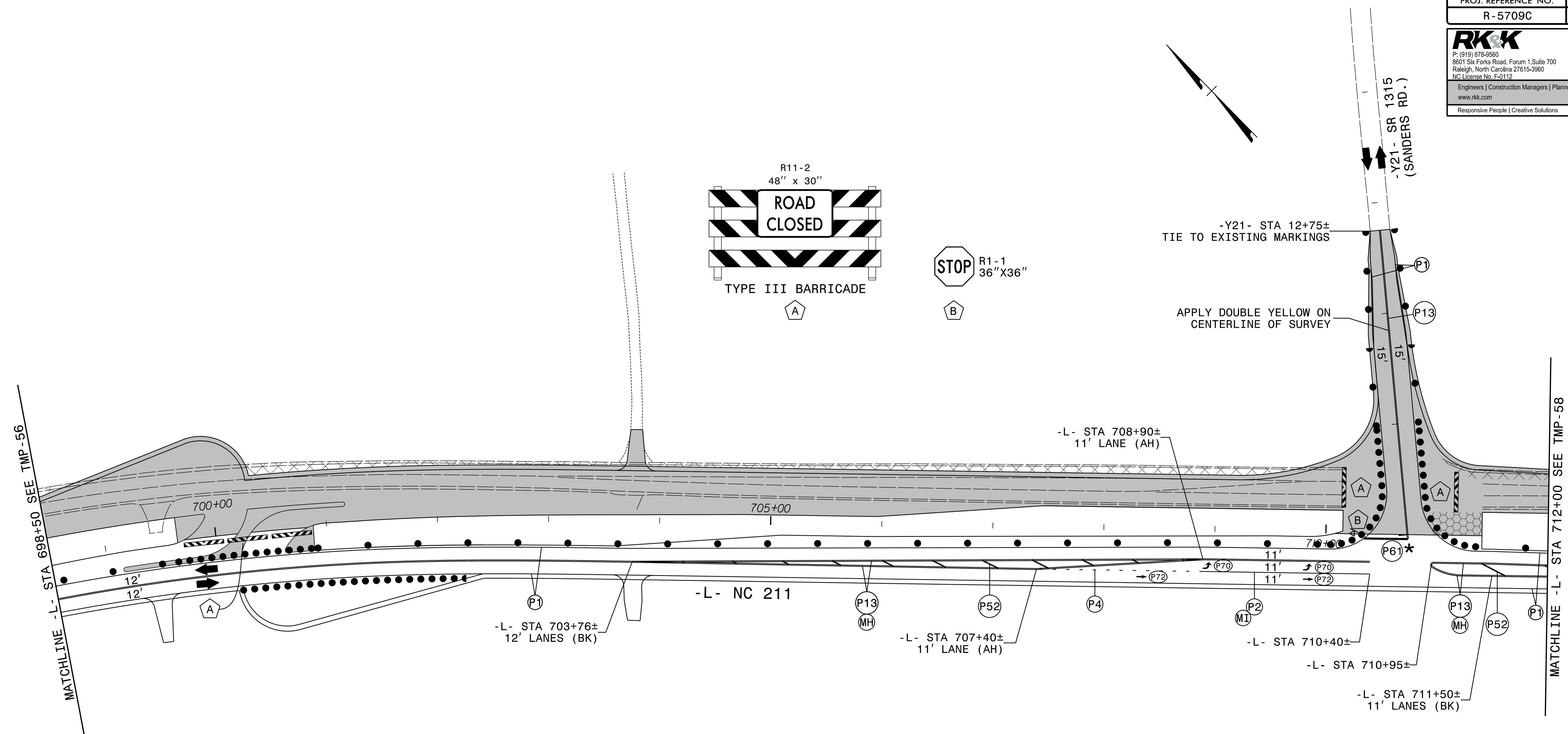

* SET BACK STOP BAR 10' FROM NC 211.

APPROVED: *Kevin W. Bisby*
 DATE: 10/15/2024

SEAL

PROFESSIONAL ENGINEER
 KEVIN W. BISBY
 SEAL 21047

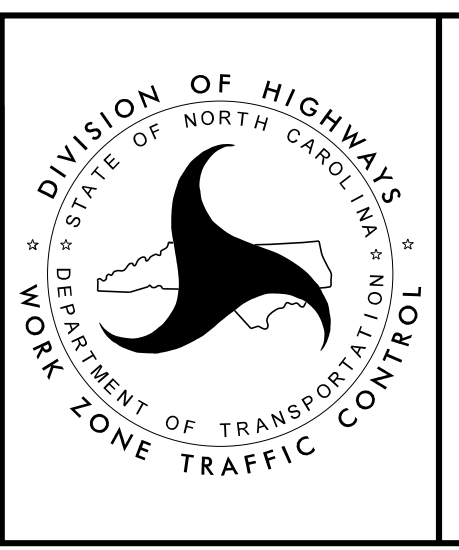

PHASE II
STEPS 1 AND 2 DETAILS

PROJ. REFERENCE NO.	SHEET NO.
R-5709C	TMP-58

RKK
 P: (919) 878-8560
 8601 Six Forks Road, Forum 1, Suite 700
 Raleigh, North Carolina 27615-3960
 NC License No. F-0112
 Engineers | Construction Managers | Planners | Scientists
 www.rkk.com
 Responsive People | Creative Solutions

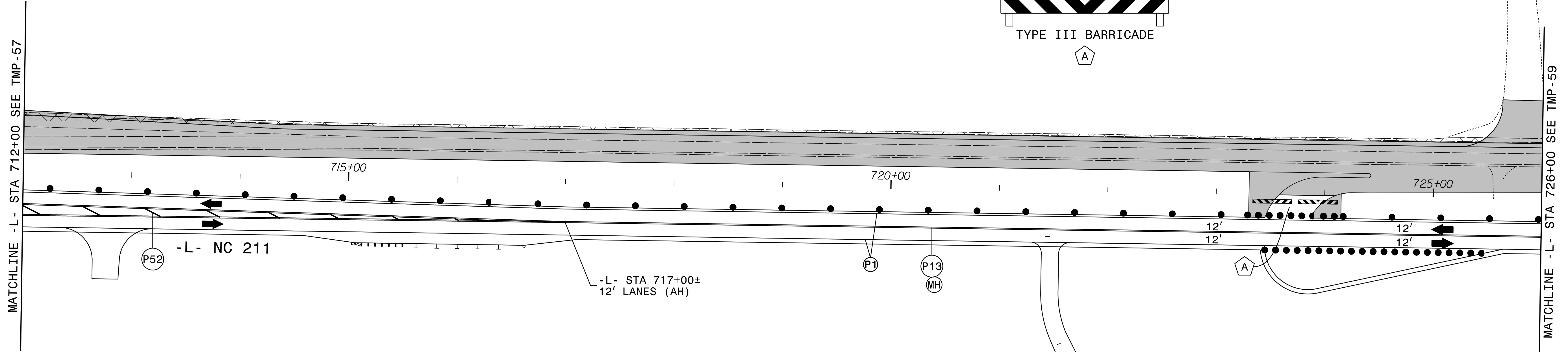
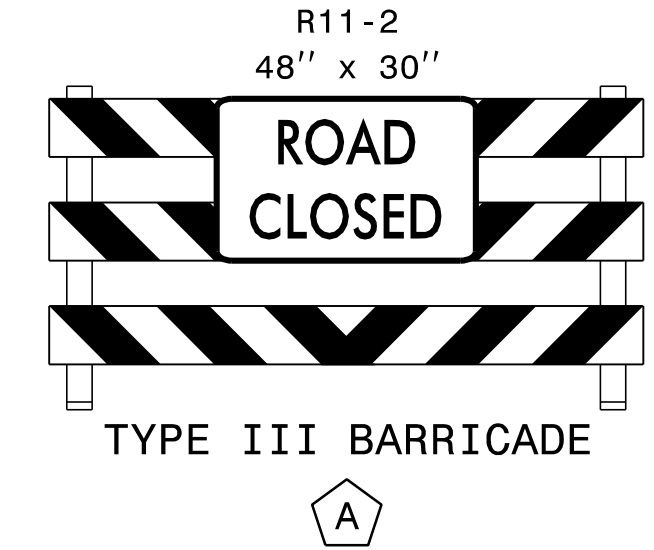

8/28/2024
 RST05_TMP_psh58.dgn
 Rolsby

APPROVED: *Kevin W. Bisby*
182PNCAP364404

DATE: 10/15/2024

SEAL

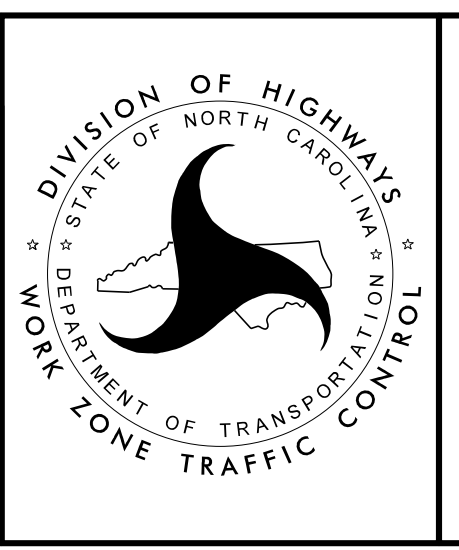

PHASE II
STEPS 1 AND 2 DETAILS

**DOCUMENT NOT CONSIDERED FINAL
 UNLESS ALL SIGNATURES COMPLETED**

PROJ. REFERENCE NO.	SHEET NO.
R-5709C	TMP-59

RKK
 P: (919) 878-8560
 8601 Six Forks Road, Forum 1, Suite 700
 Raleigh, North Carolina 27615-3960
 NC License No. F-0112
 Engineers | Construction Managers | Planners | Scientists
 www.rkk.com
 Responsive People | Creative Solutions

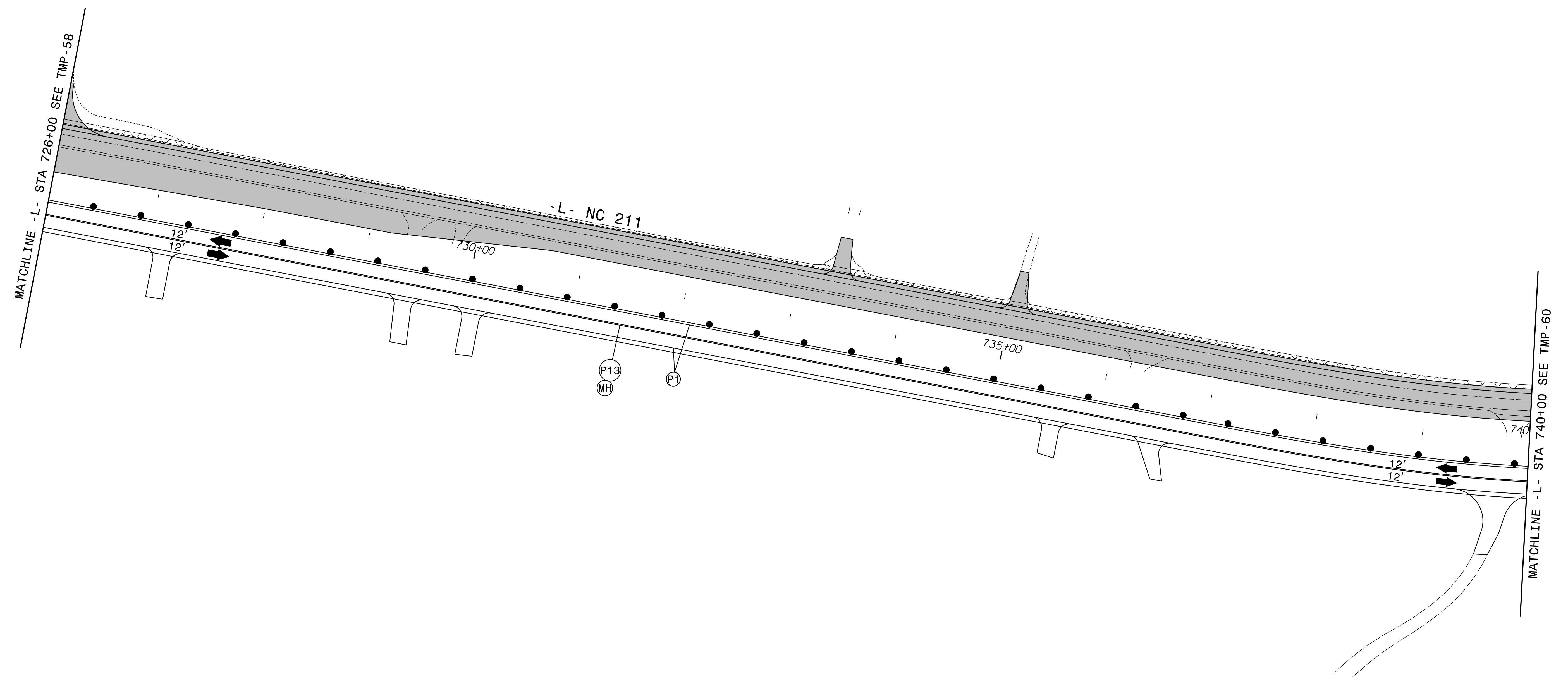
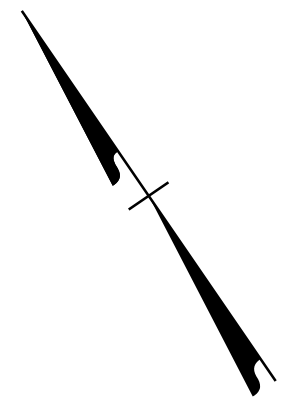

8/28/2024
 RST05_TMP_psh59.dgn
 Rolsby

APPROVED: *Kevin W. Bisby*
382P8CA2P384404

DATE: 10/15/2024

SEAL

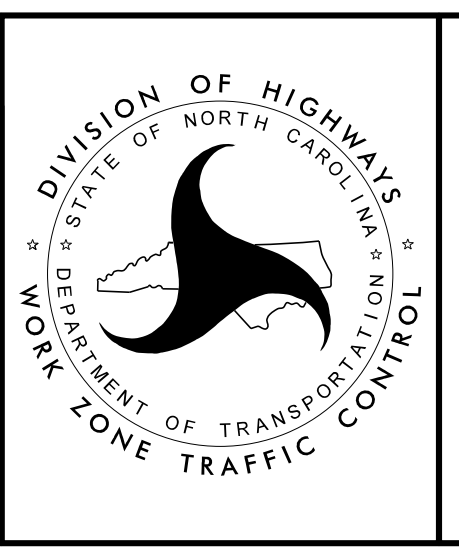

PHASE II
STEPS 1 AND 2 DETAILS

**DOCUMENT NOT CONSIDERED FINAL
 UNLESS ALL SIGNATURES COMPLETED**

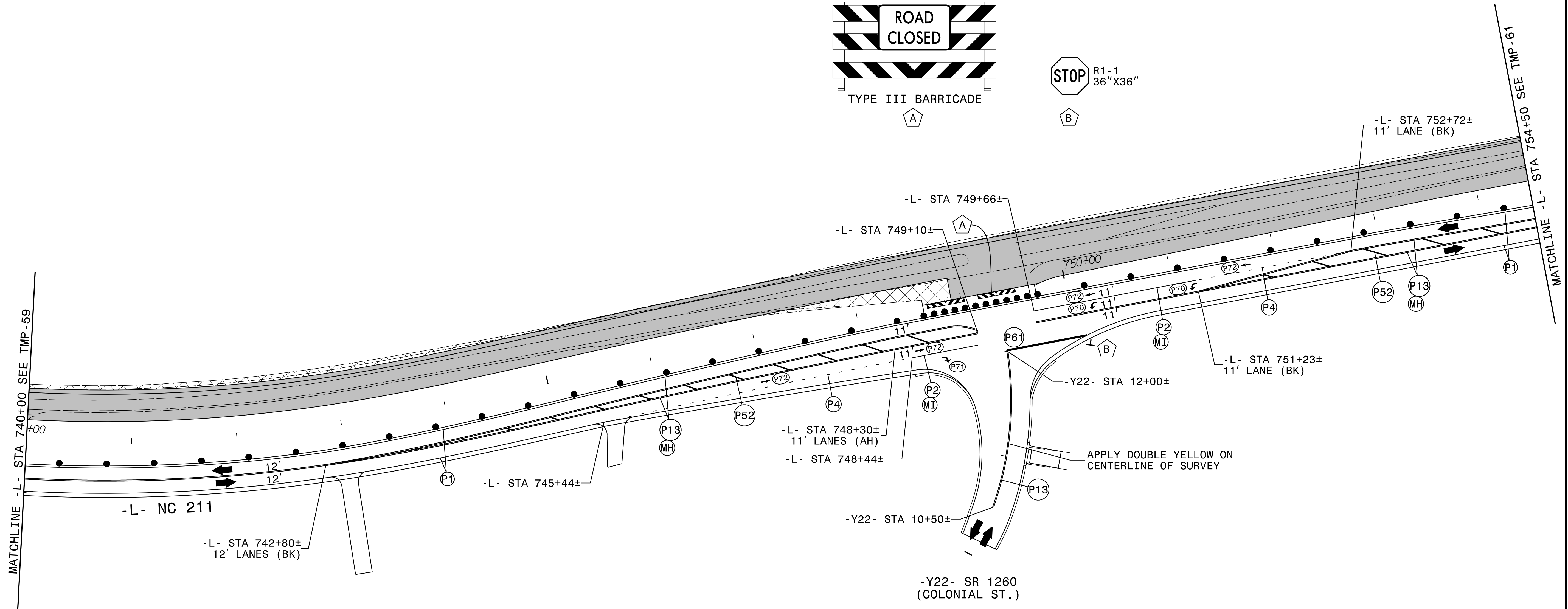
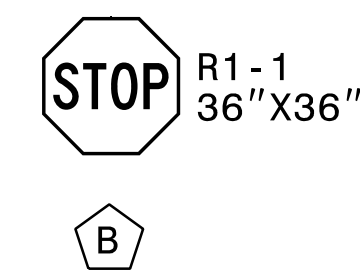
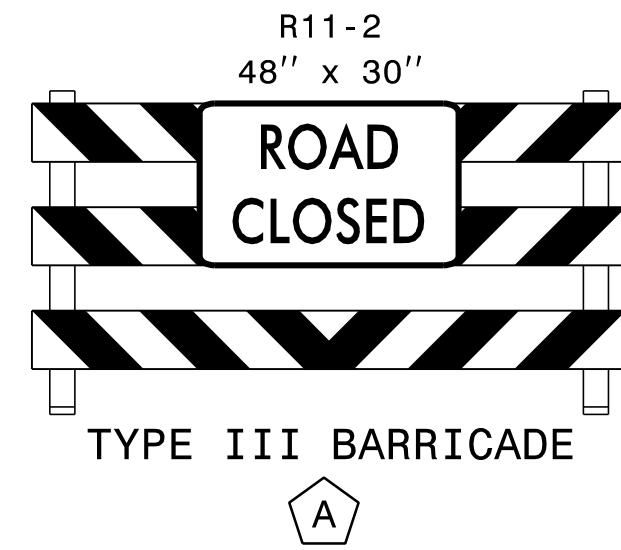
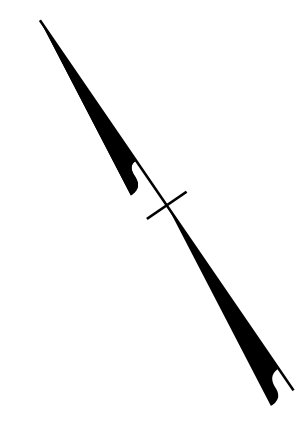

8/28/2024
 RST05_TMP_pst60.dgn
 Robby

APPROVED: Kevin W. Bisby
382P8CA2P384404

DATE: 10/15/2024

SEAL

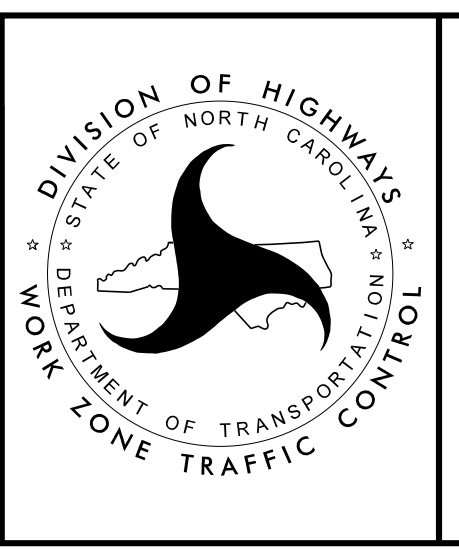

PHASE II
STEPS 1 AND 2 DETAILS

**DOCUMENT NOT CONSIDERED FINAL
 UNLESS ALL SIGNATURES COMPLETED**

PROJ. REFERENCE NO.	SHEET NO.
R-5709C	TMP-61

RKK
 P: (919) 878-8560
 8601 Six Forks Road, Forum 1, Suite 700
 Raleigh, North Carolina 27615-3960
 NC License No. F-0112
 Engineers | Construction Managers | Planners | Scientists
 www.rkk.com
 Responsive People | Creative Solutions

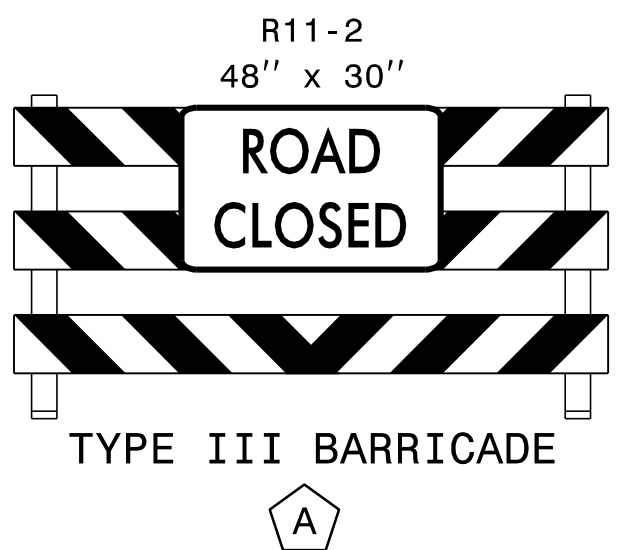
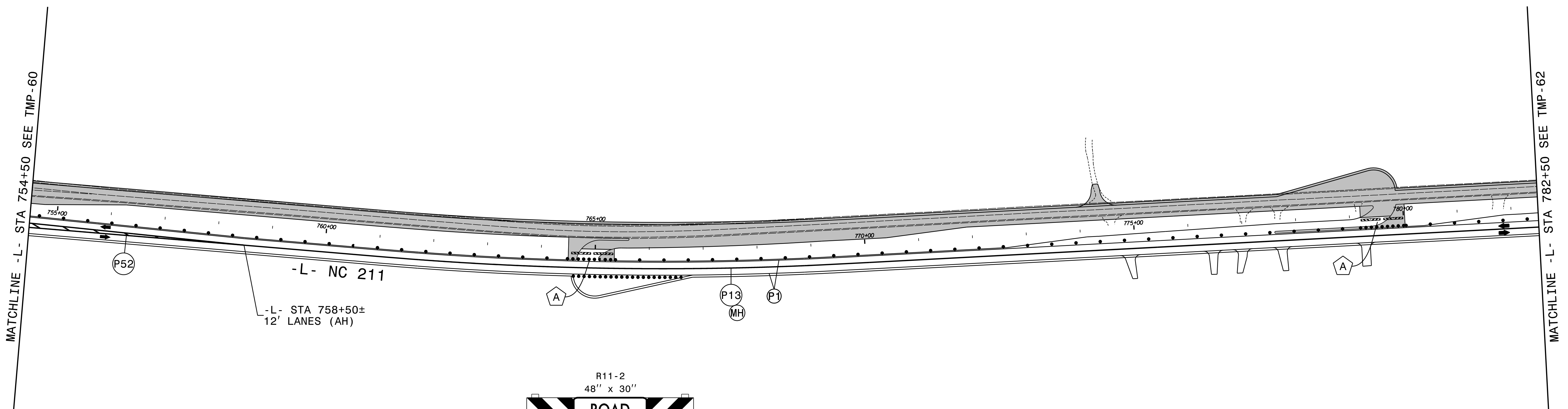
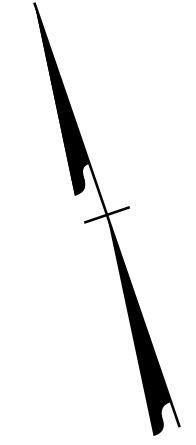

8/28/2024
 RST05_TMP_psh61.dgn
 Rolsby

APPROVED: Kevin W. Bisby
382P8CA2P384404

DATE: 10/15/2024

SEAL

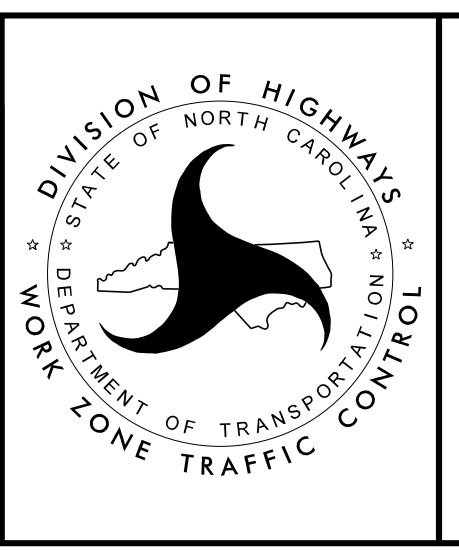

PHASE II
STEPS 1 AND 2 DETAILS

**DOCUMENT NOT CONSIDERED FINAL
 UNLESS ALL SIGNATURES COMPLETED**

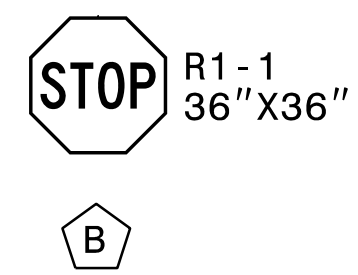
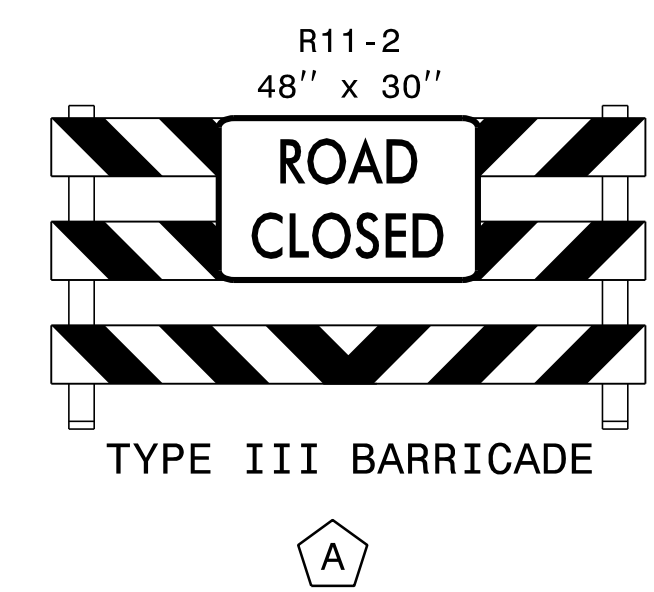
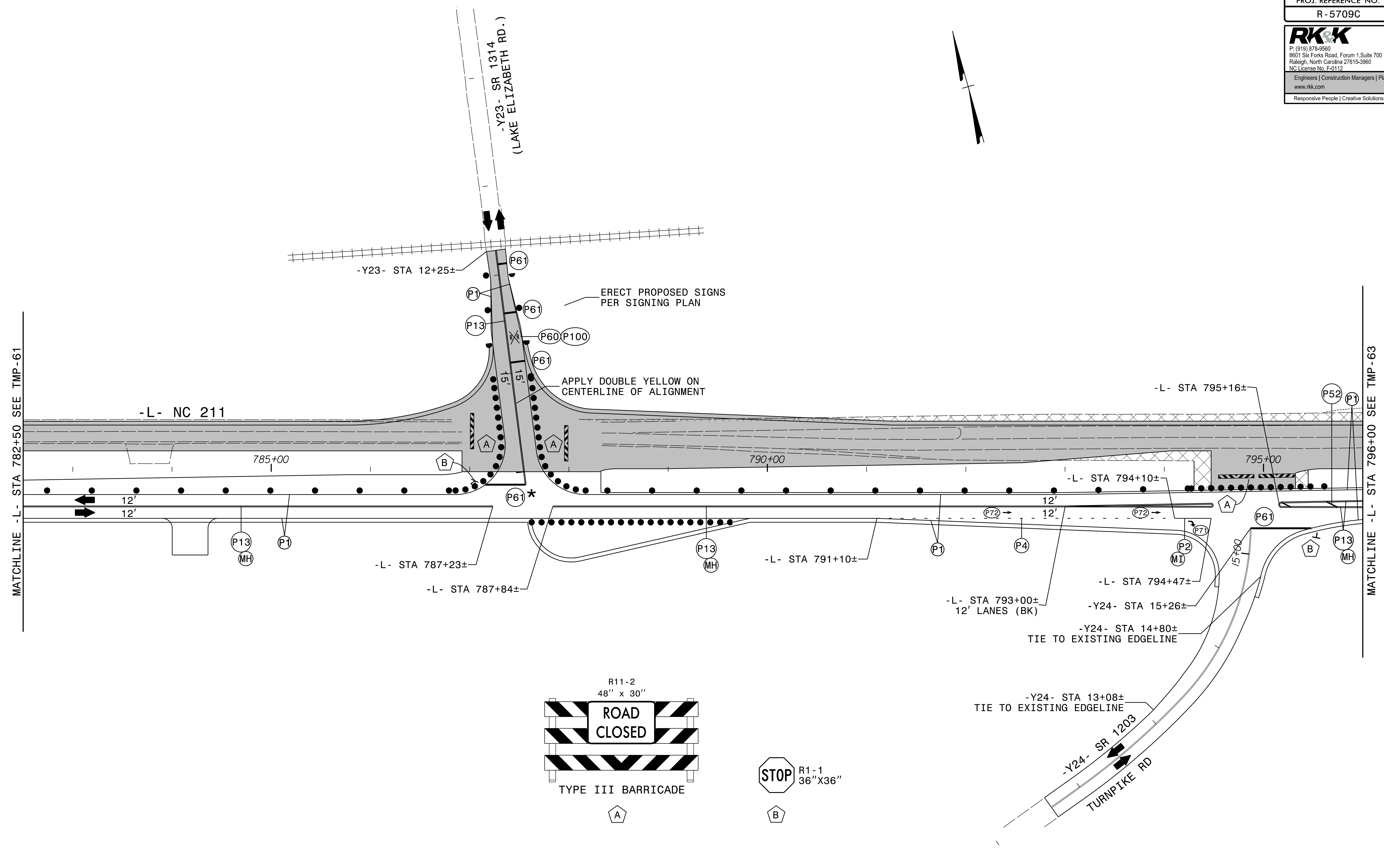

* SET BACK STOP BAR 10' FROM NC 211
 RAILROAD SYMBOLS AND ASSOCIATED STOP BARS SHALL
 BE LOCATED PER RDWY STD 1205.11.

APPROVED: *Kevin W. Bisby*
18298CA23P364404
 DATE: 10/15/2024

SEAL

PHASE II
 STEPS 1 AND 2 DETAILS

8/28/2024
 RST05_TMP_pst62.dgn
 Rolsby

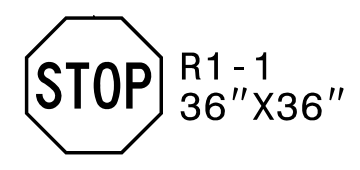
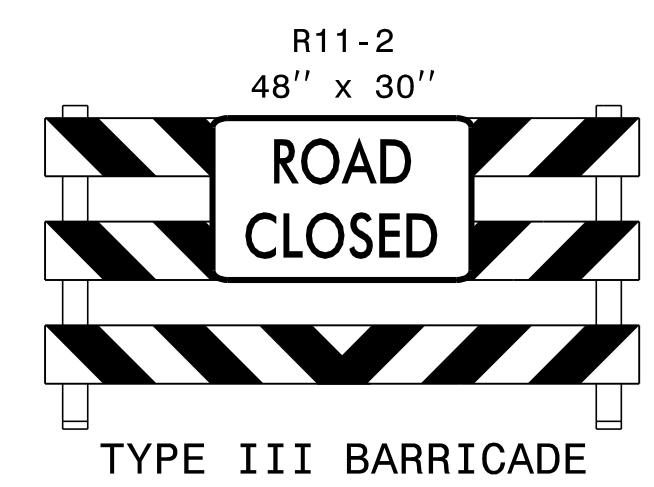
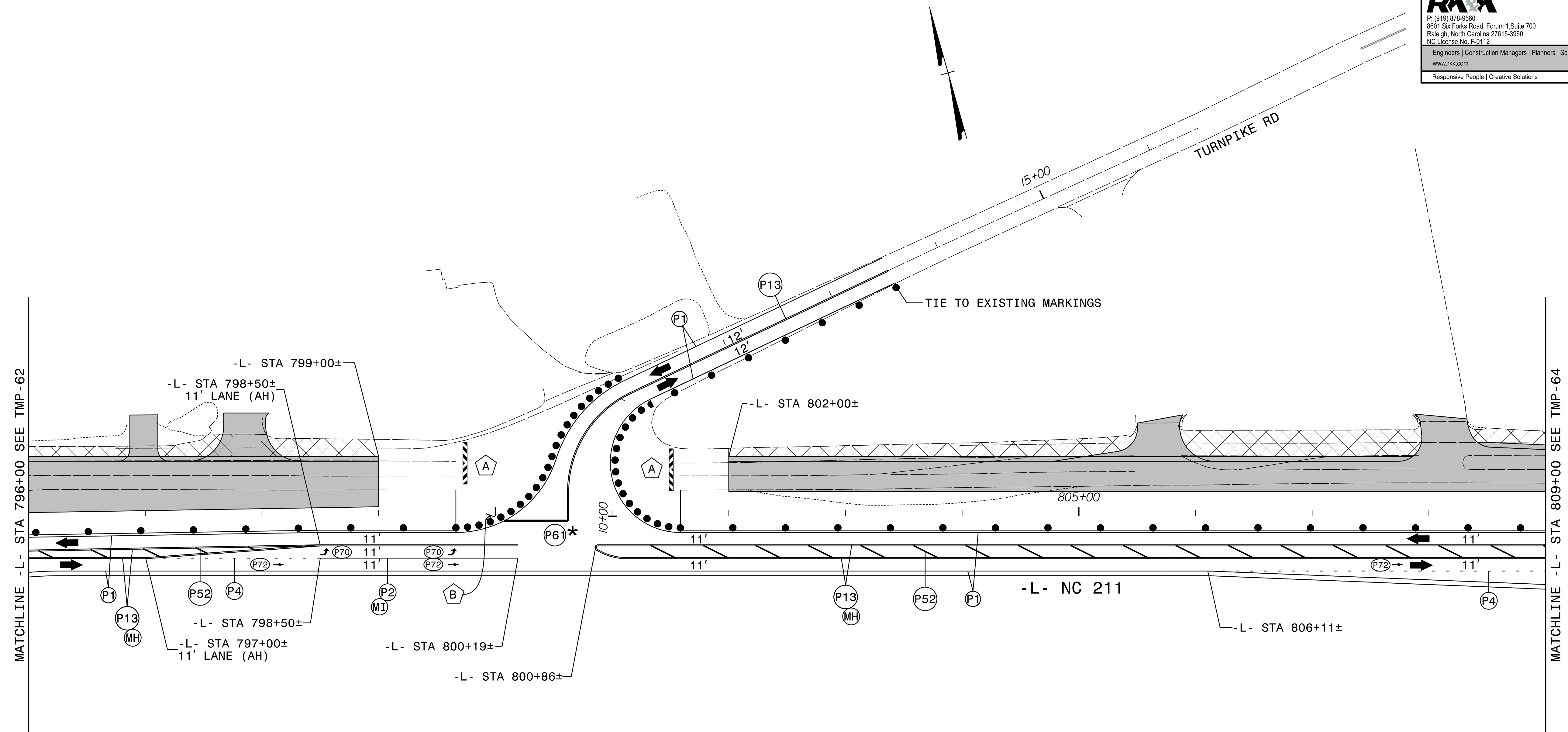

* SET BACK STOP BAR 10' FROM NC 211.

APPROVED: *Kevin W. Bisby*
 DATE: 10/15/2024

SEAL

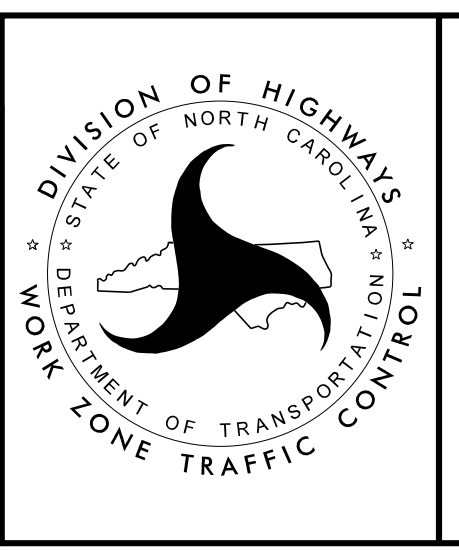

PHASE II
 STEPS 1 AND 2 DETAILS

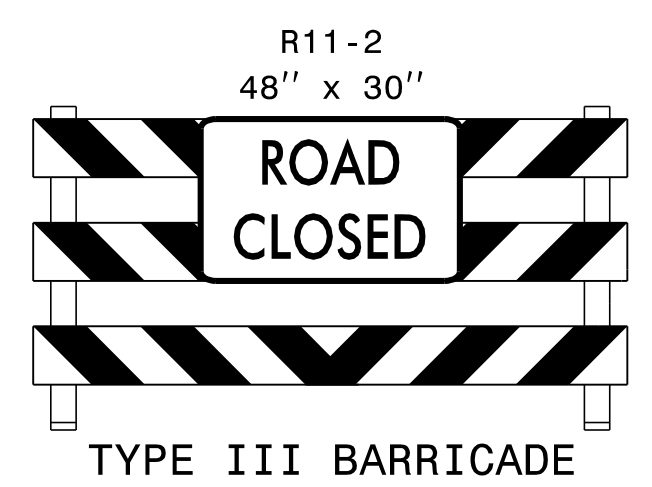
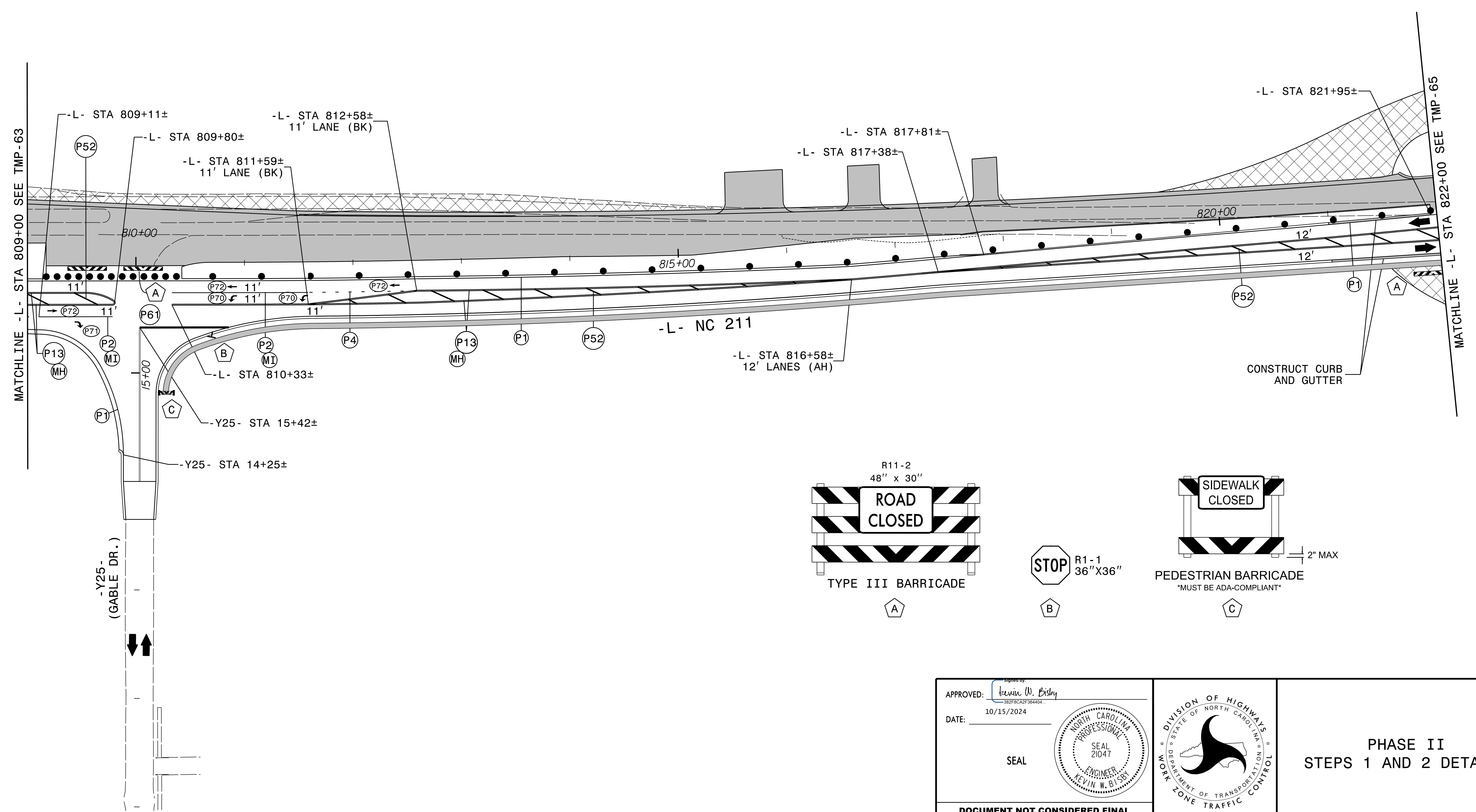
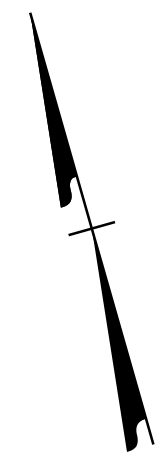

8/28/2024
 RST05_TMP_psh64.dgn
 Rolsby

APPROVED: *Kevin W. Bisby*
3629823P 364404

DATE: 10/15/2024

SEAL

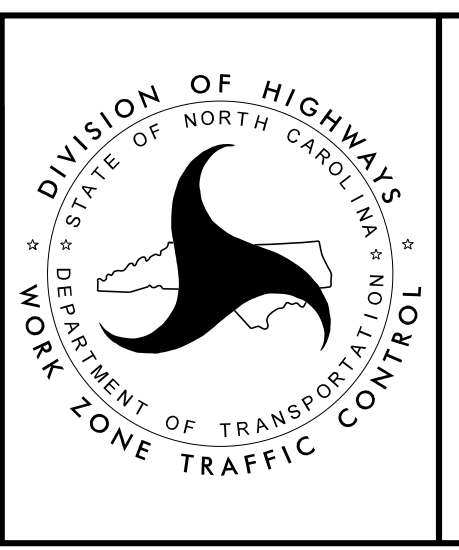

PHASE II
STEPS 1 AND 2 DETAILS

**DOCUMENT NOT CONSIDERED FINAL
 UNLESS ALL SIGNATURES COMPLETED**

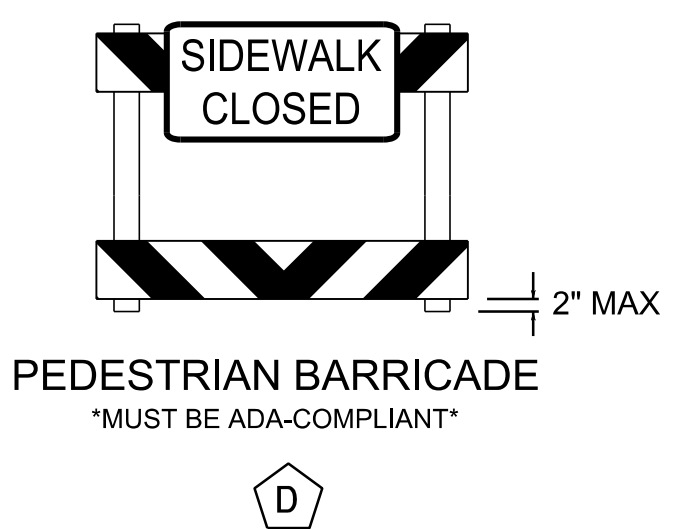
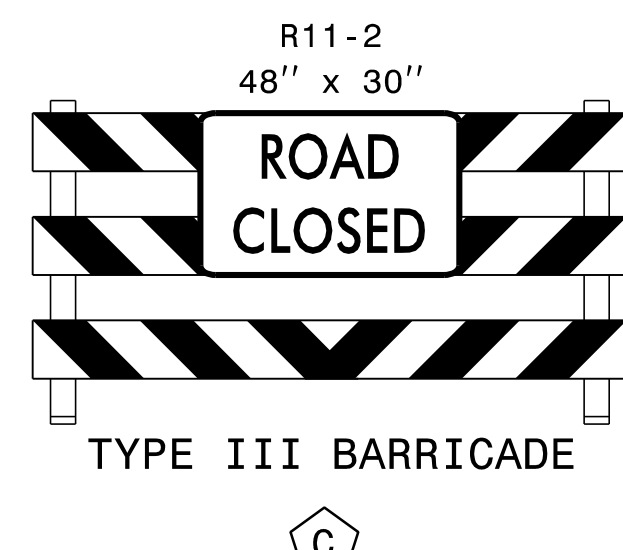
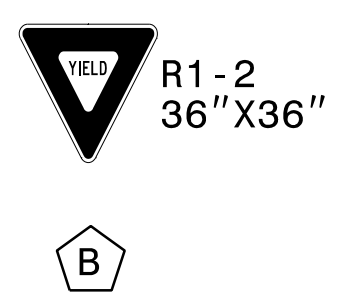
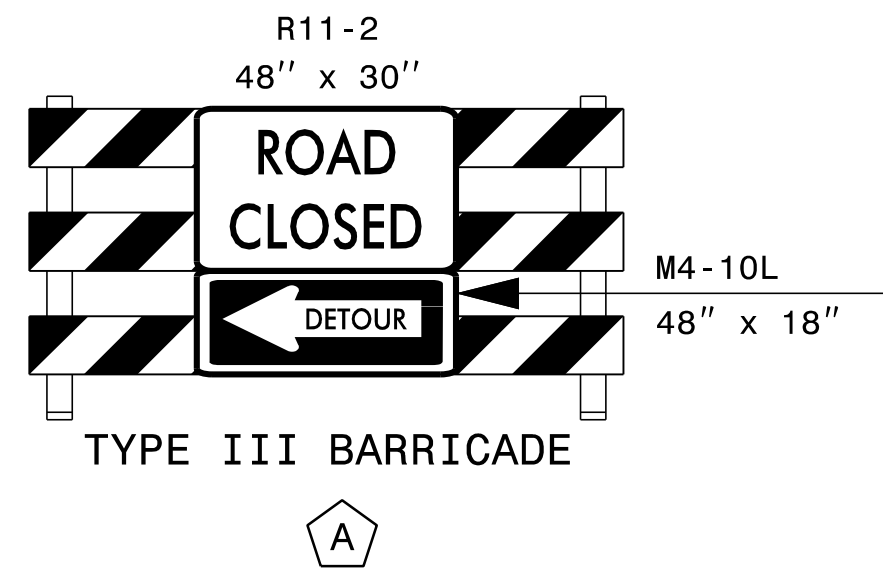
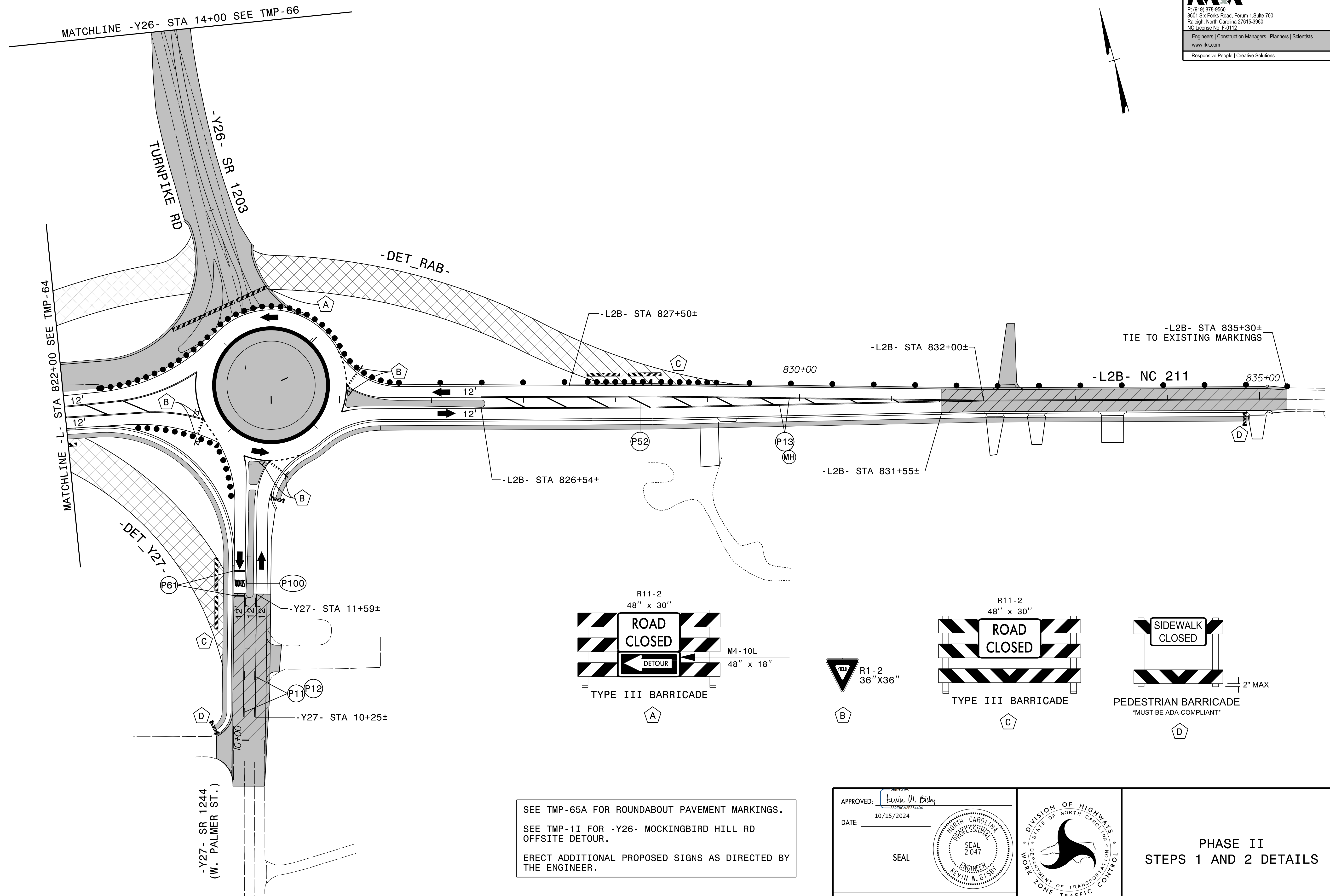

SEE TMP-65A FOR ROUNDABOUT PAVEMENT MARKINGS.
 SEE TMP-1I FOR -Y26- MOCKINGBIRD HILL RD OFFSITE DETOUR.
 ERECT ADDITIONAL PROPOSED SIGNS AS DIRECTED BY THE ENGINEER.

APPROVED: *Kevin W. Bisby*
10/15/2024

DATE: 10/15/2024

SEAL

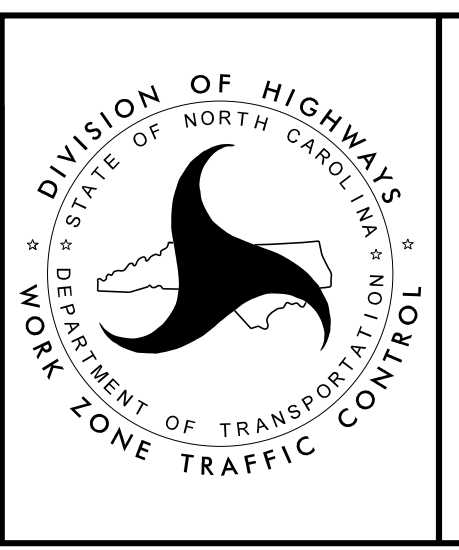

PHASE II
 STEPS 1 AND 2 DETAILS

8/28/2024
 RST05_TMP_psh65.dgn
 Robby

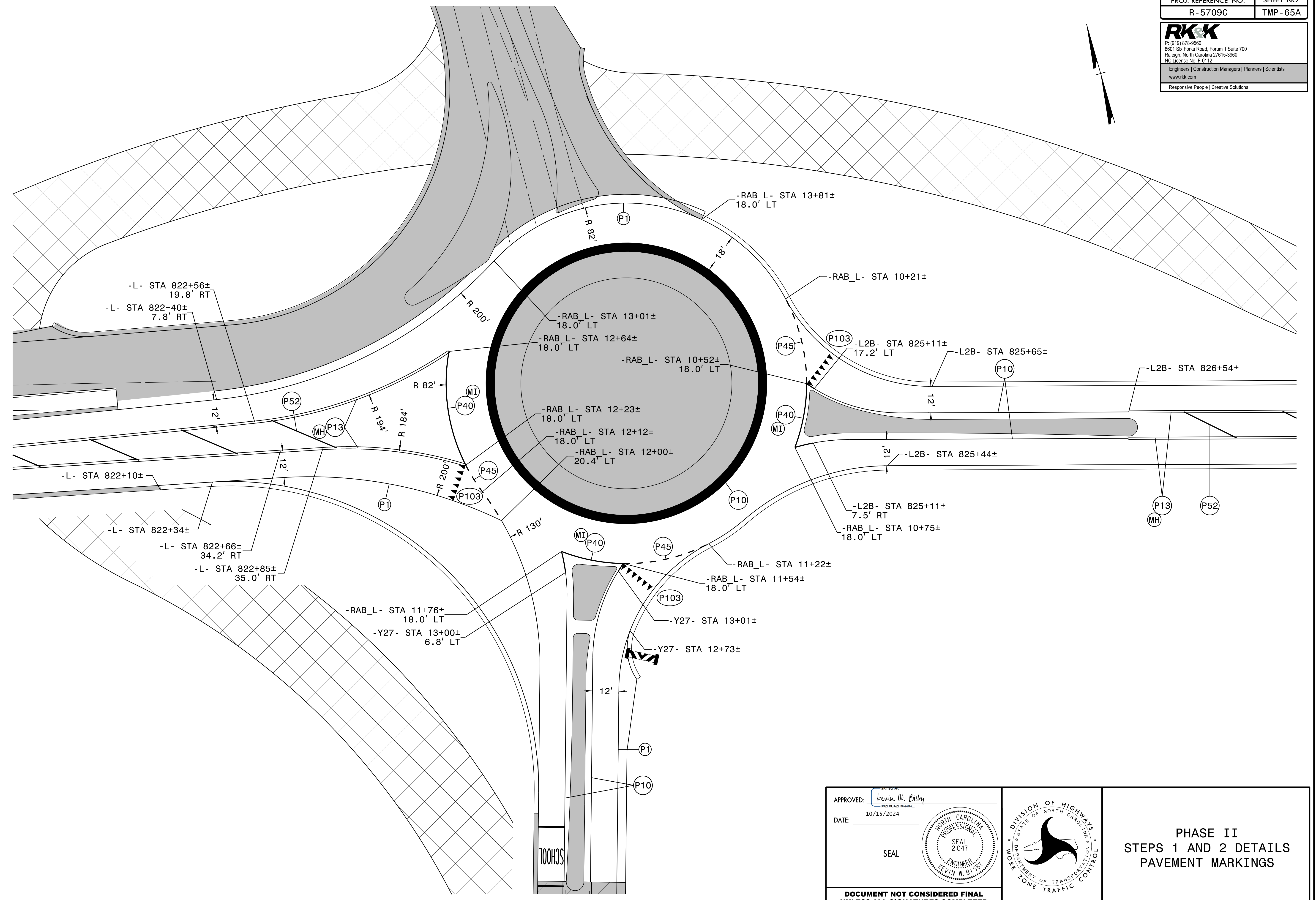
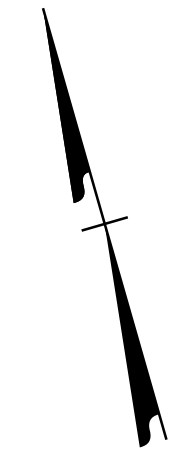

8/28/2024
 RST05_TMP_pst65A.dgn
 RStebby

APPROVED: Kevin W. Bisby
18298CA2P364404

DATE: 10/15/2024

SEAL

**DOCUMENT NOT CONSIDERED FINAL
 UNLESS ALL SIGNATURES COMPLETED**

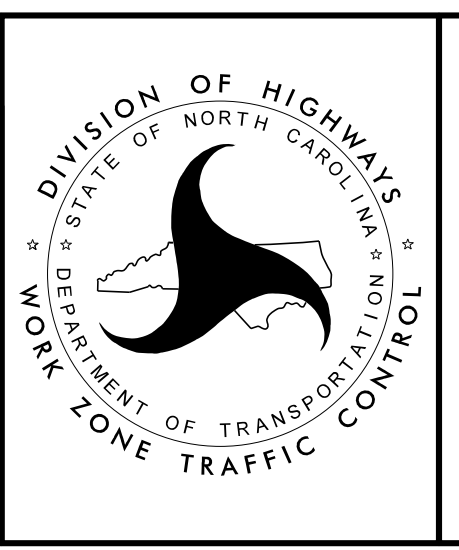

**PHASE II
 STEPS 1 AND 2 DETAILS
 PAVEMENT MARKINGS**

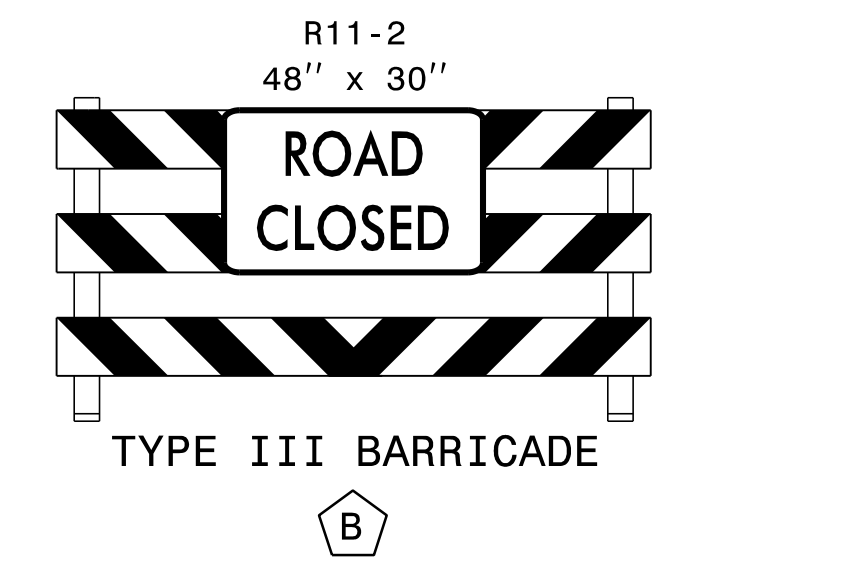
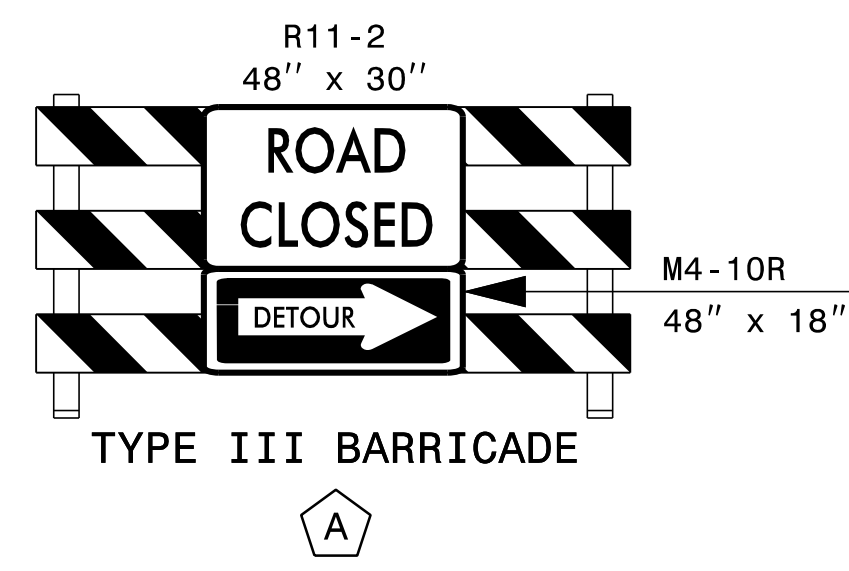
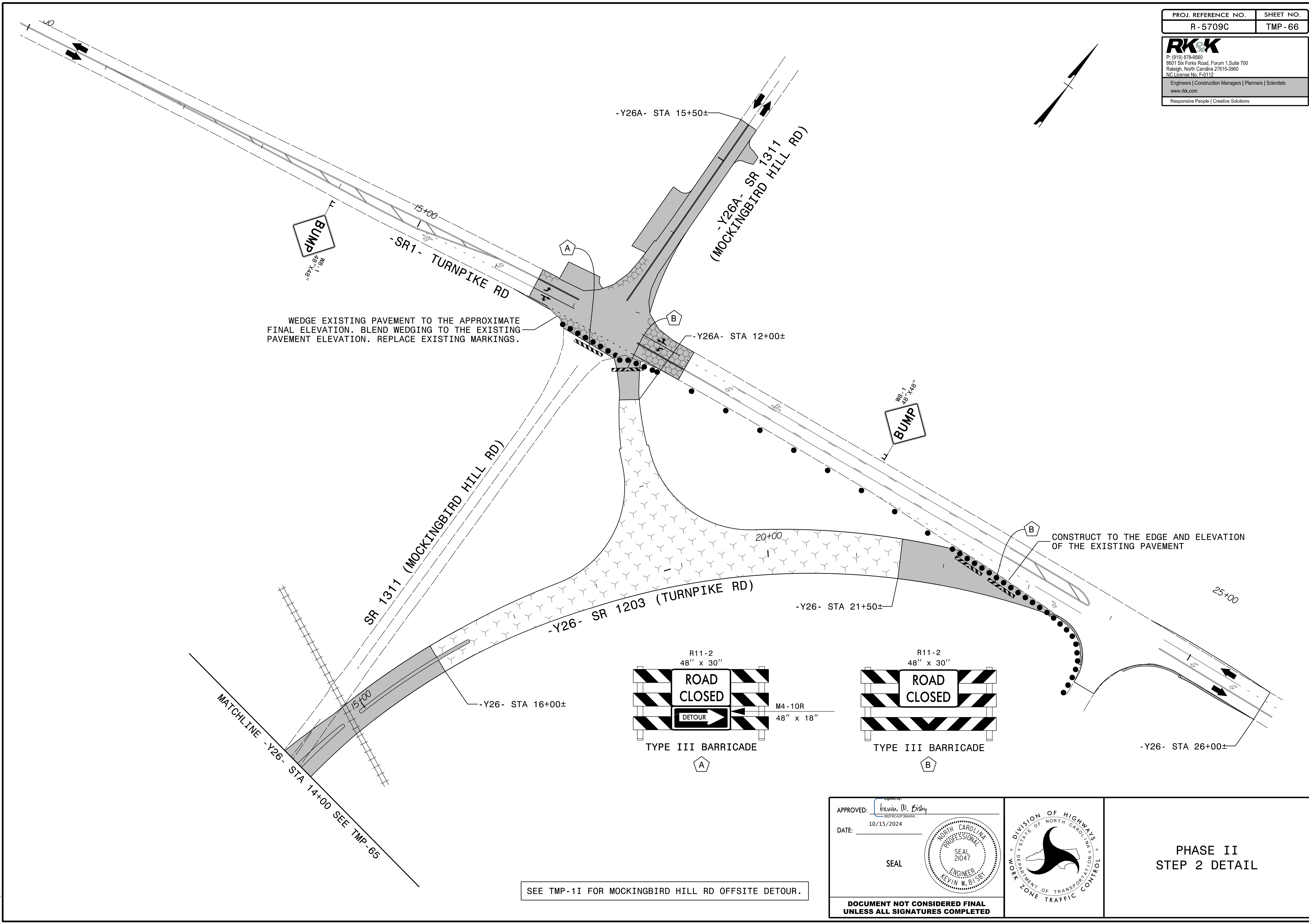
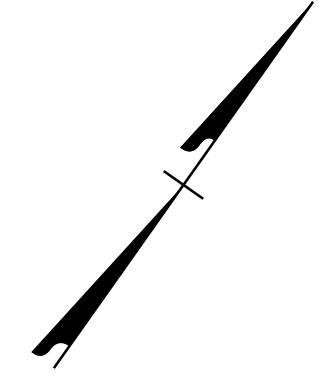

SEE TMP-1I FOR MOCKINGBIRD HILL RD OFFSITE DETOUR.

APPROVED: *Kevin W. Bisby*
10/15/2024
 DATE: 10/15/2024

SEAL

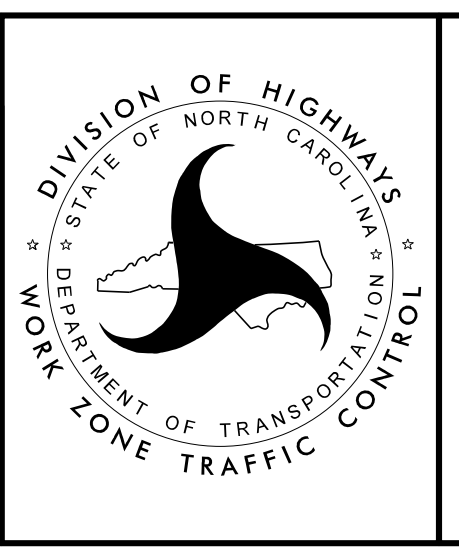

PHASE II
 STEP 2 DETAIL

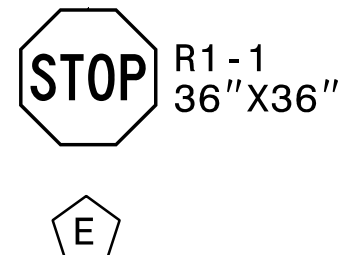
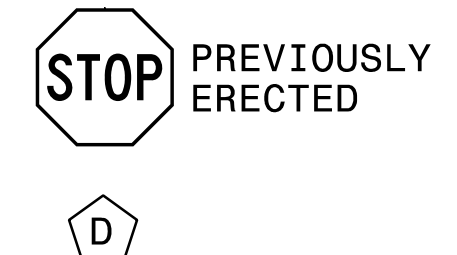
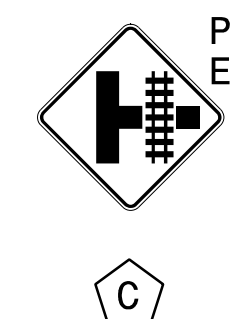
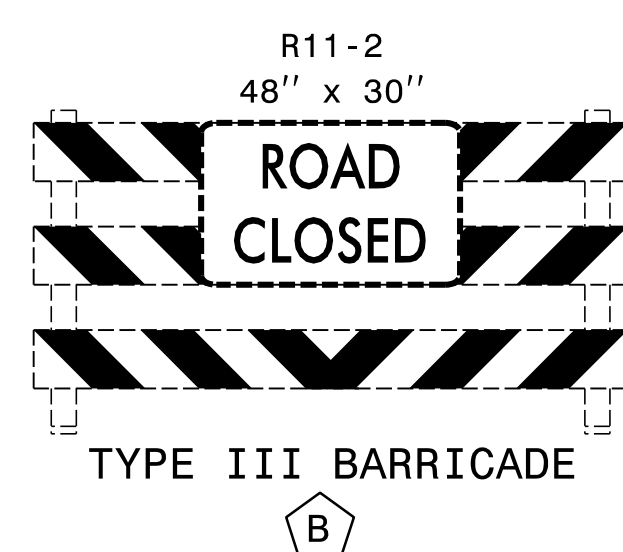
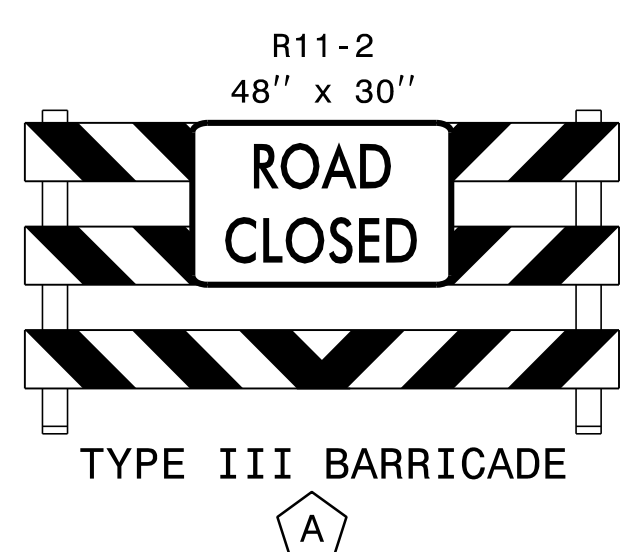
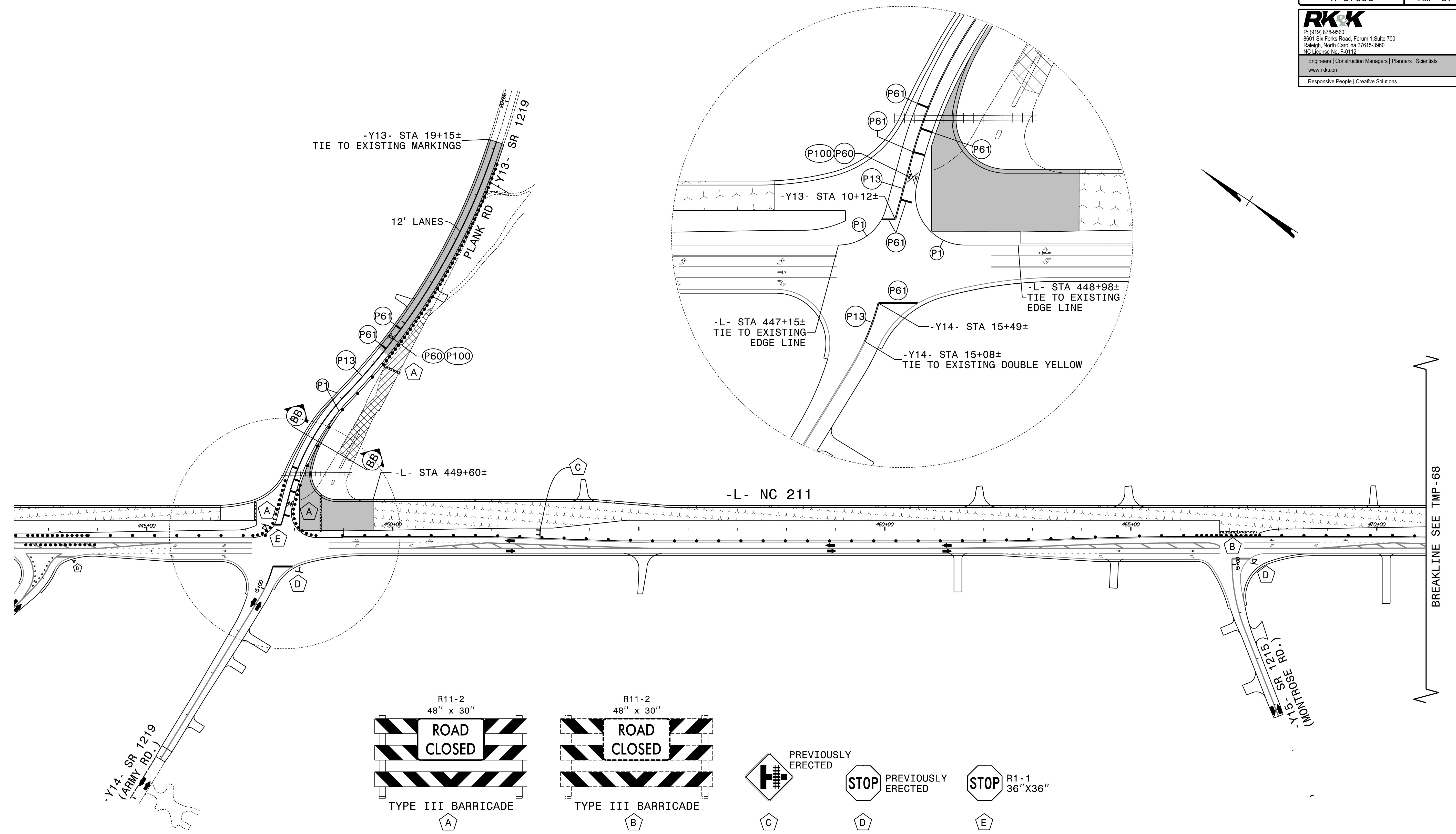

SEE TMP-67A FOR SECTION VIEW.
 RAILROAD SYMBOLS AND ASSOCIATED STOP BARS SHALL
 BE LOCATED PER RDWY STD 1205.11.

APPROVED: Kevin W. Bisby
382F8CA2F364404

DATE: 10/15/2024

SEAL

**DOCUMENT NOT CONSIDERED FINAL
 UNLESS ALL SIGNATURES COMPLETED**

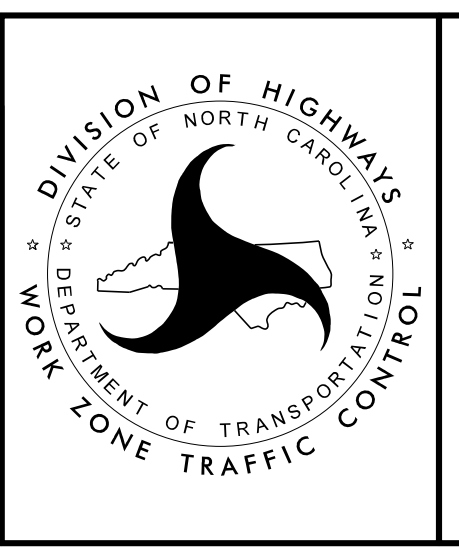

PHASE II
 STEP 3 DETAIL

PROJ. REFERENCE NO.	SHEET NO.
R-5709C	TMP-67A

RKK
 P: (919) 878-8560
 8601 Six Forks Road, Forum 1, Suite 700
 Raleigh, North Carolina 27615-3960
 NC License No. F-0112
 Engineers | Construction Managers | Planners | Scientists
 www.rkk.com
 Responsive People | Creative Solutions

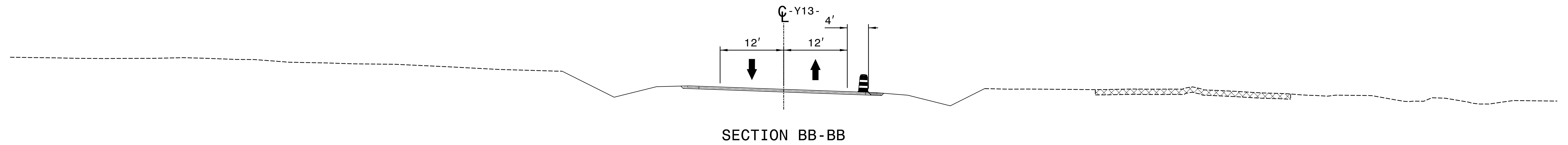

8/28/2024
 RST05_TMP_IPSH67A.dgn
 R01sbby

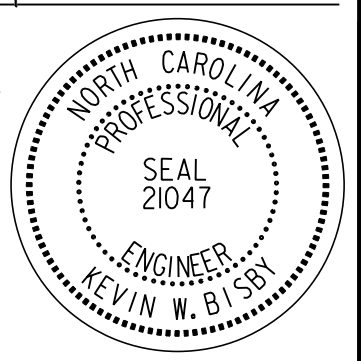
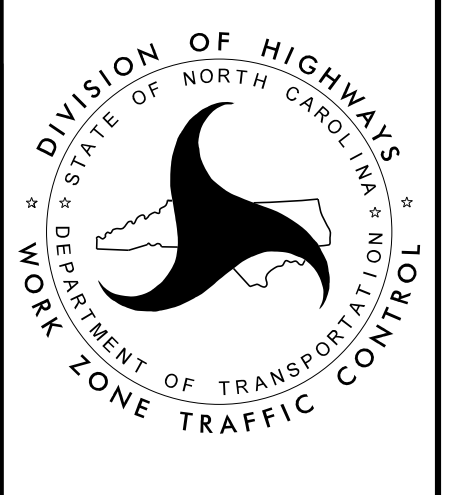
APPROVED: <i>Kevin W. Bisby</i> <small>182P8CA2P384404</small> DATE: 10/15/2024 SEAL		 <p style="text-align: center;"> PHASE II STEP 3 DETAIL </p>
DOCUMENT NOT CONSIDERED FINAL UNLESS ALL SIGNATURES COMPLETED		

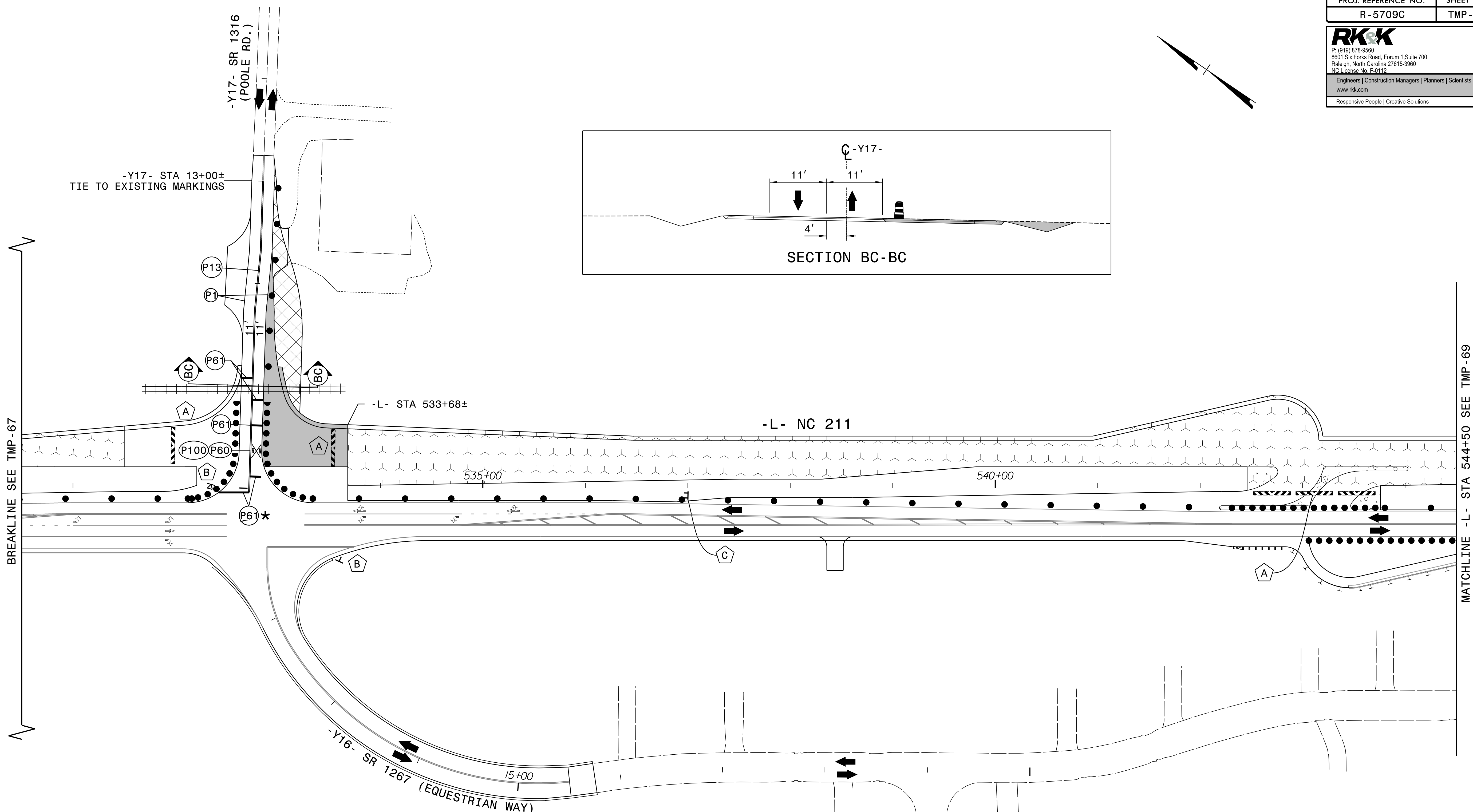
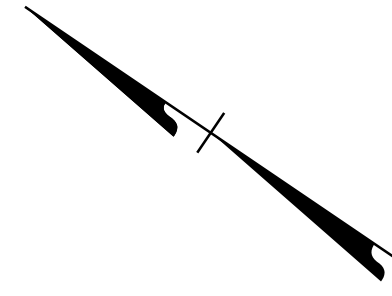

BREAKLINE SEE TMP-67

MATCHLINE -L- STA 544+50 SEE TMP-69

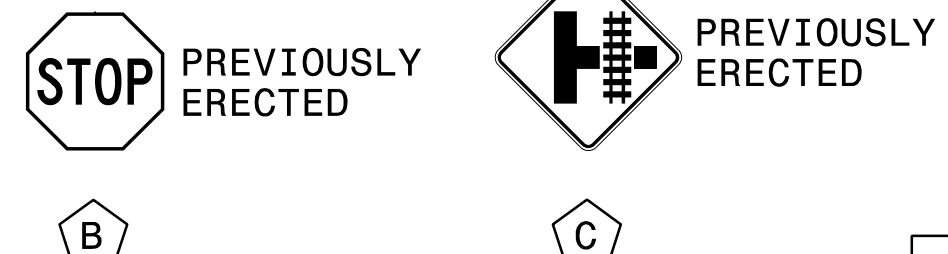
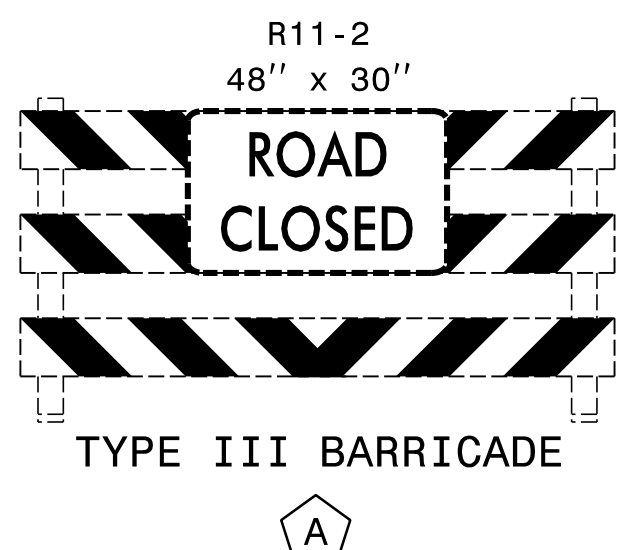

* SET BACK STOP BAR 10' FROM NC 211.
 RAILROAD SYMBOLS AND ASSOCIATED STOP BARS SHALL BE LOCATED PER RDWY STD 1205.11.

APPROVED: *Kevin W. Bisby*
1829 RCAF 364404
 DATE: 10/15/2024
 SEAL
 NORTH CAROLINA PROFESSIONAL ENGINEER
 KEVIN W. BISBY
 SEAL 21047

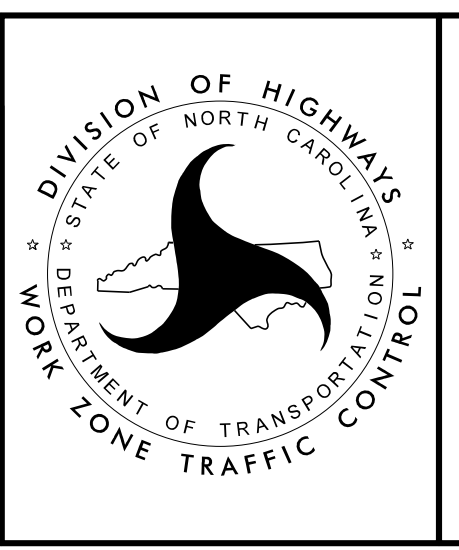

PHASE II
 STEP 3 DETAIL

DOCUMENT NOT CONSIDERED FINAL
 UNLESS ALL SIGNATURES COMPLETED

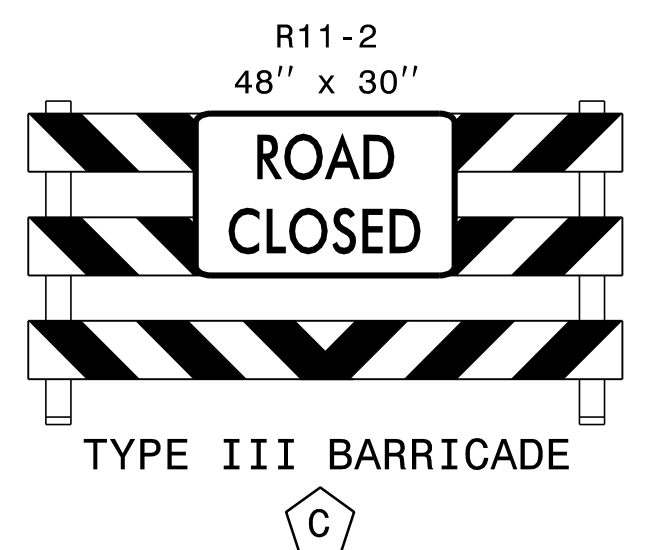
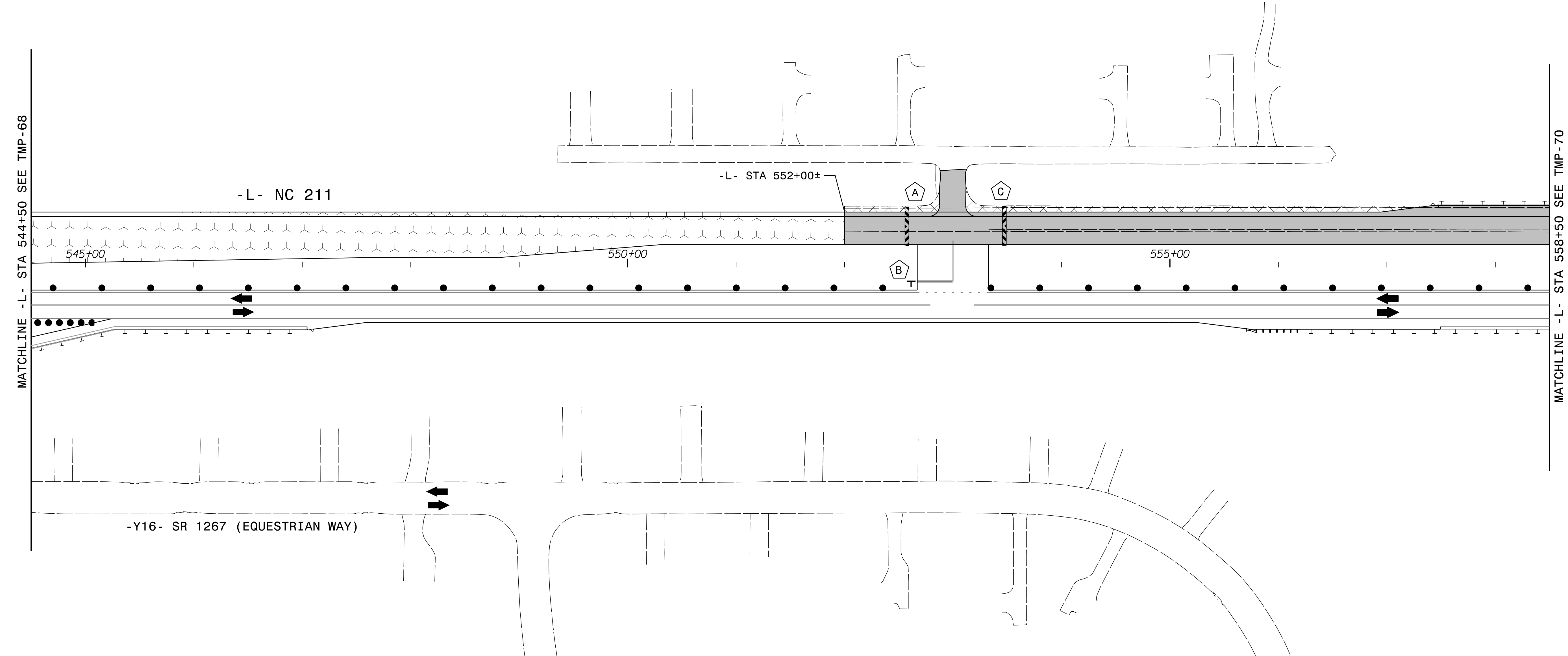
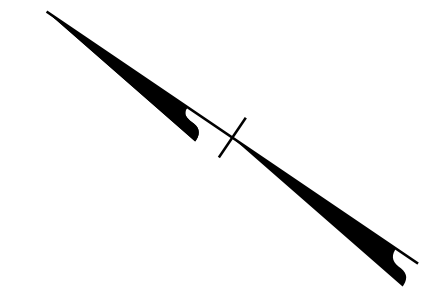

APPROVED: *Kevin W. Bisby*
362P0CA2P364404

DATE: 10/15/2024

SEAL

**DOCUMENT NOT CONSIDERED FINAL
UNLESS ALL SIGNATURES COMPLETED**

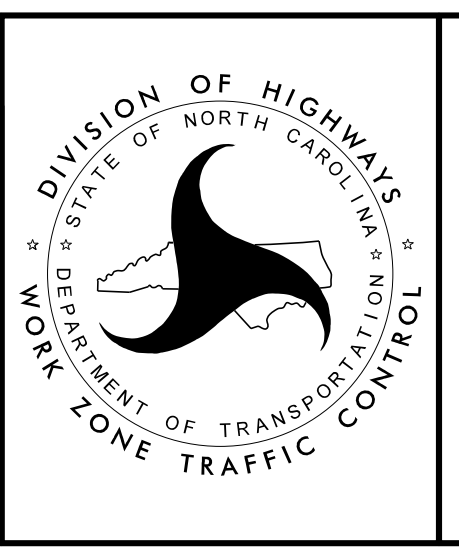

PHASE II
STEP 3 DETAIL

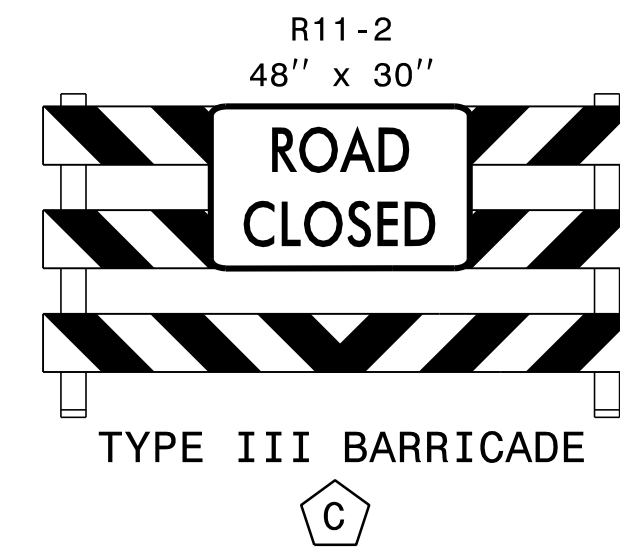
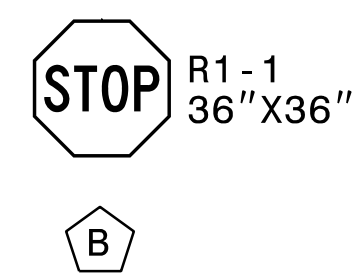
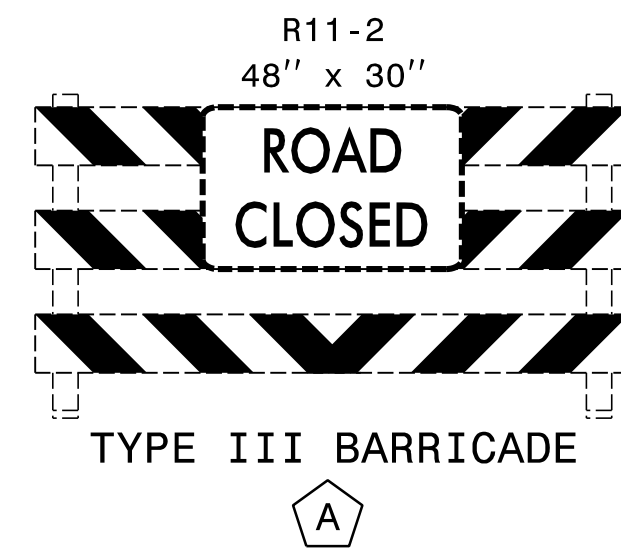
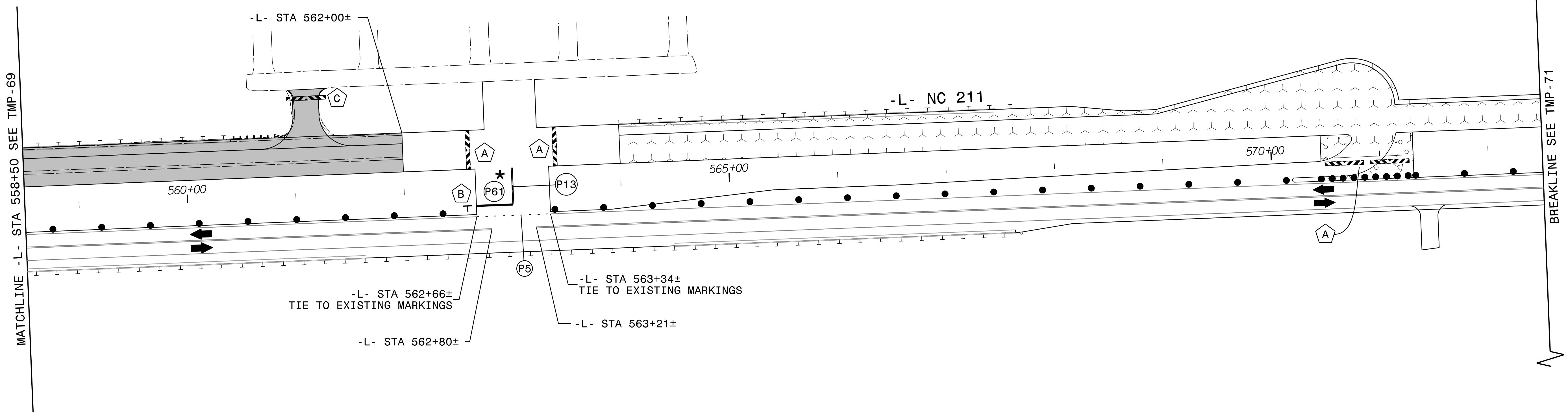
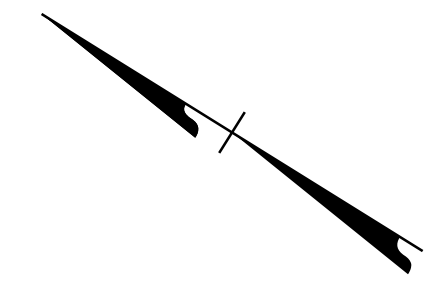

* SET BACK STOP BAR 10' FROM NC 211.

8/28/2024
 RST05_TMP-psht70.dgn
 Robby

APPROVED: *Kevin W. Bisby*
36298239364404

DATE: 10/15/2024

SEAL

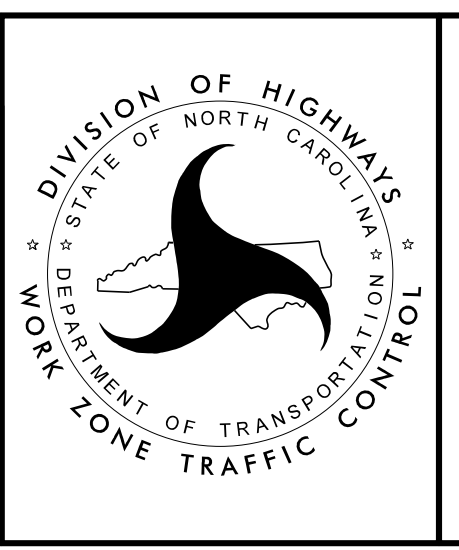

PHASE II
 STEP 3 DETAIL

DOCUMENT NOT CONSIDERED FINAL
 UNLESS ALL SIGNATURES COMPLETED

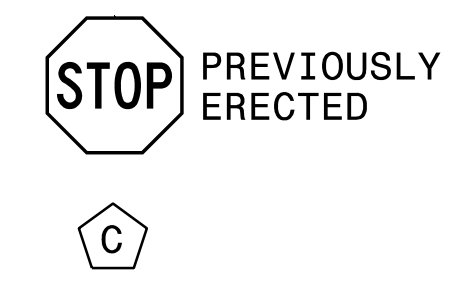
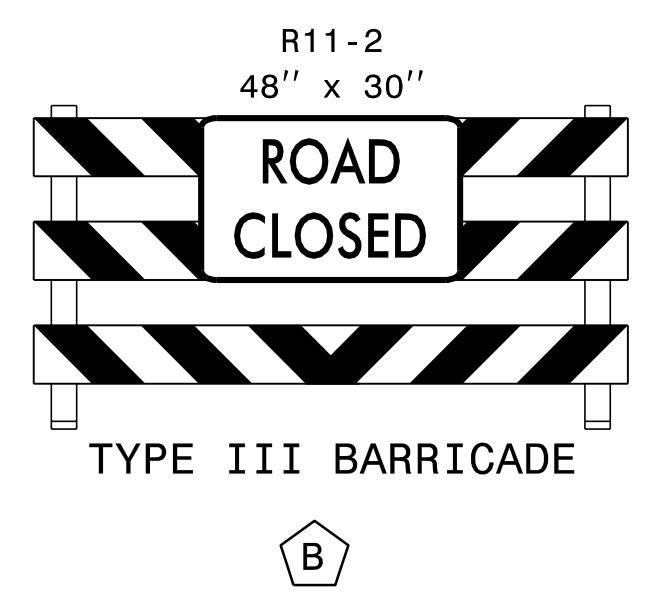
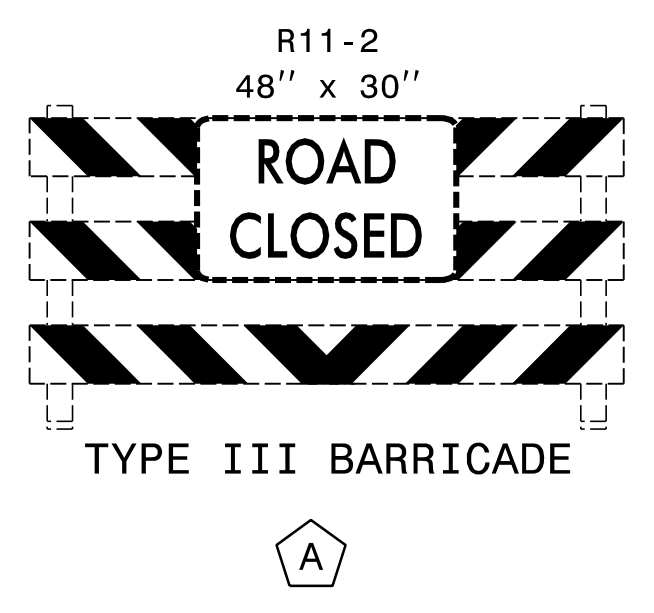
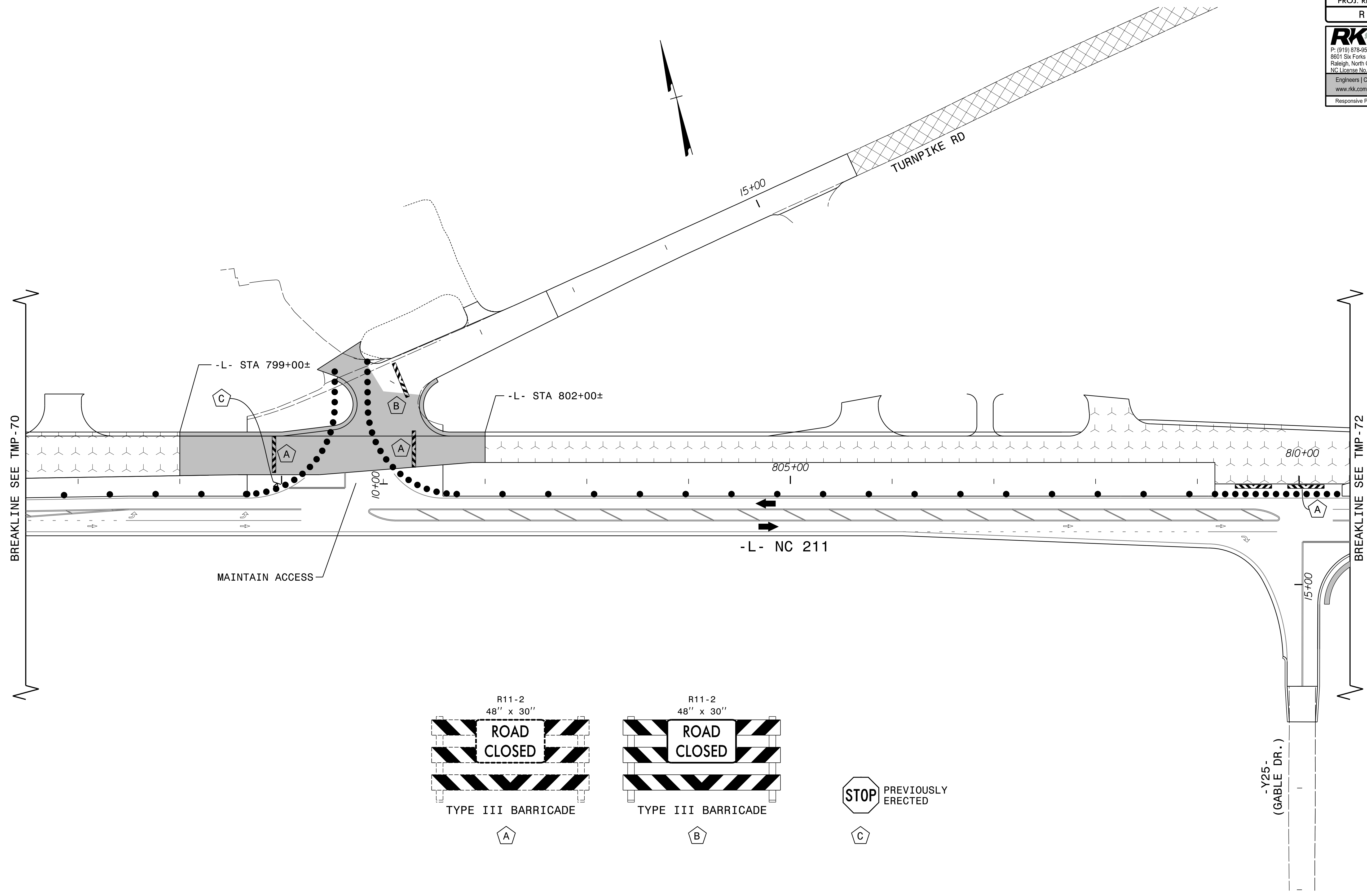

8/28/2024
 RST05_TMP_psh71.dgn
 Rolsby

APPROVED: *Kevin W. Bisby*
362P9CA2P364404

DATE: 10/15/2024

SEAL

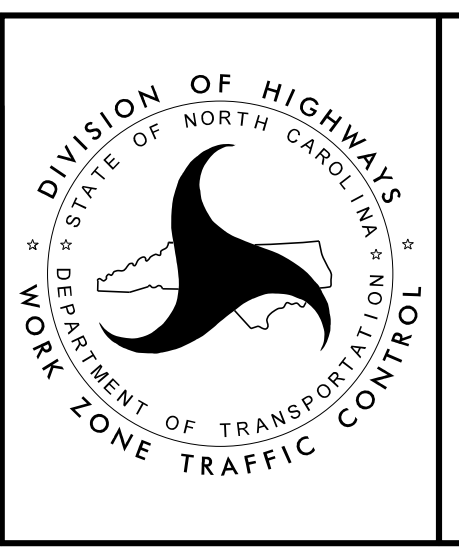

PHASE II
STEP 3 DETAIL

**DOCUMENT NOT CONSIDERED FINAL
 UNLESS ALL SIGNATURES COMPLETED**

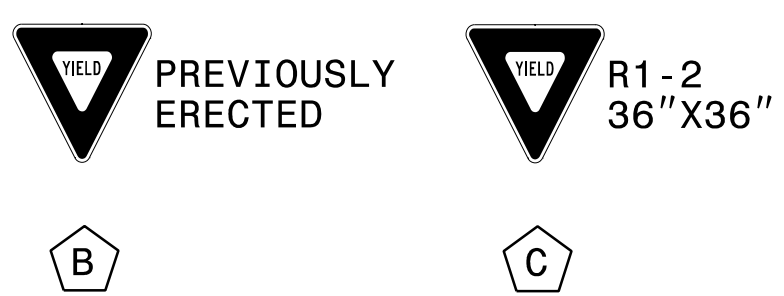
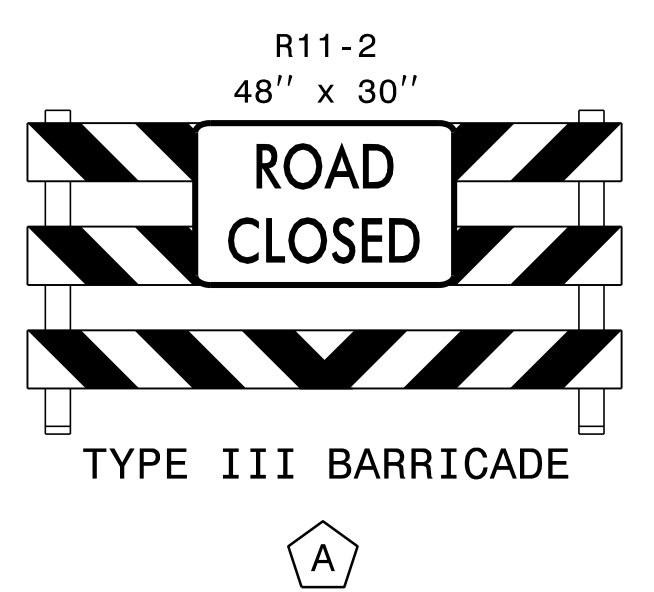
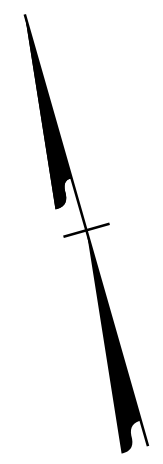
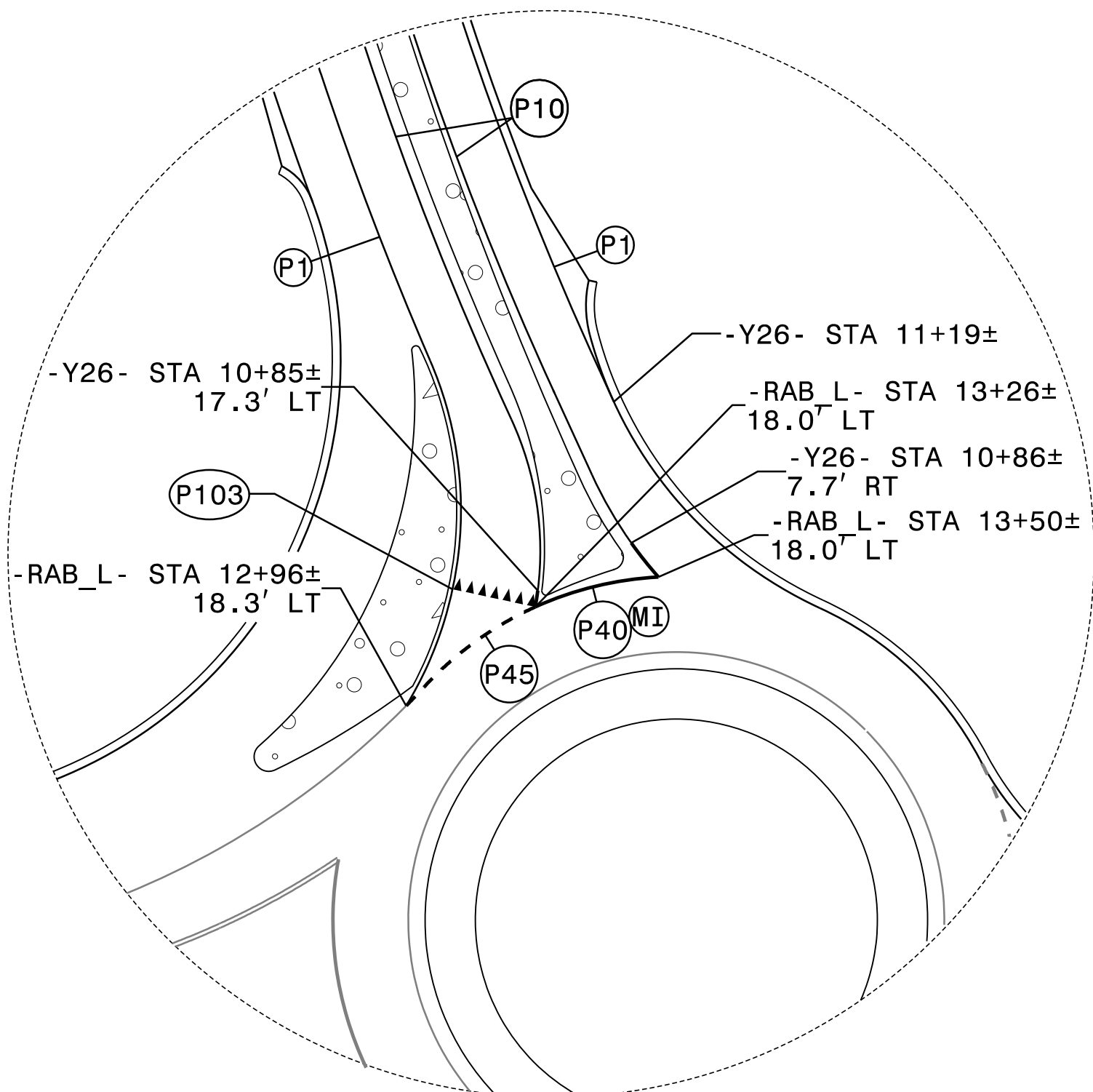
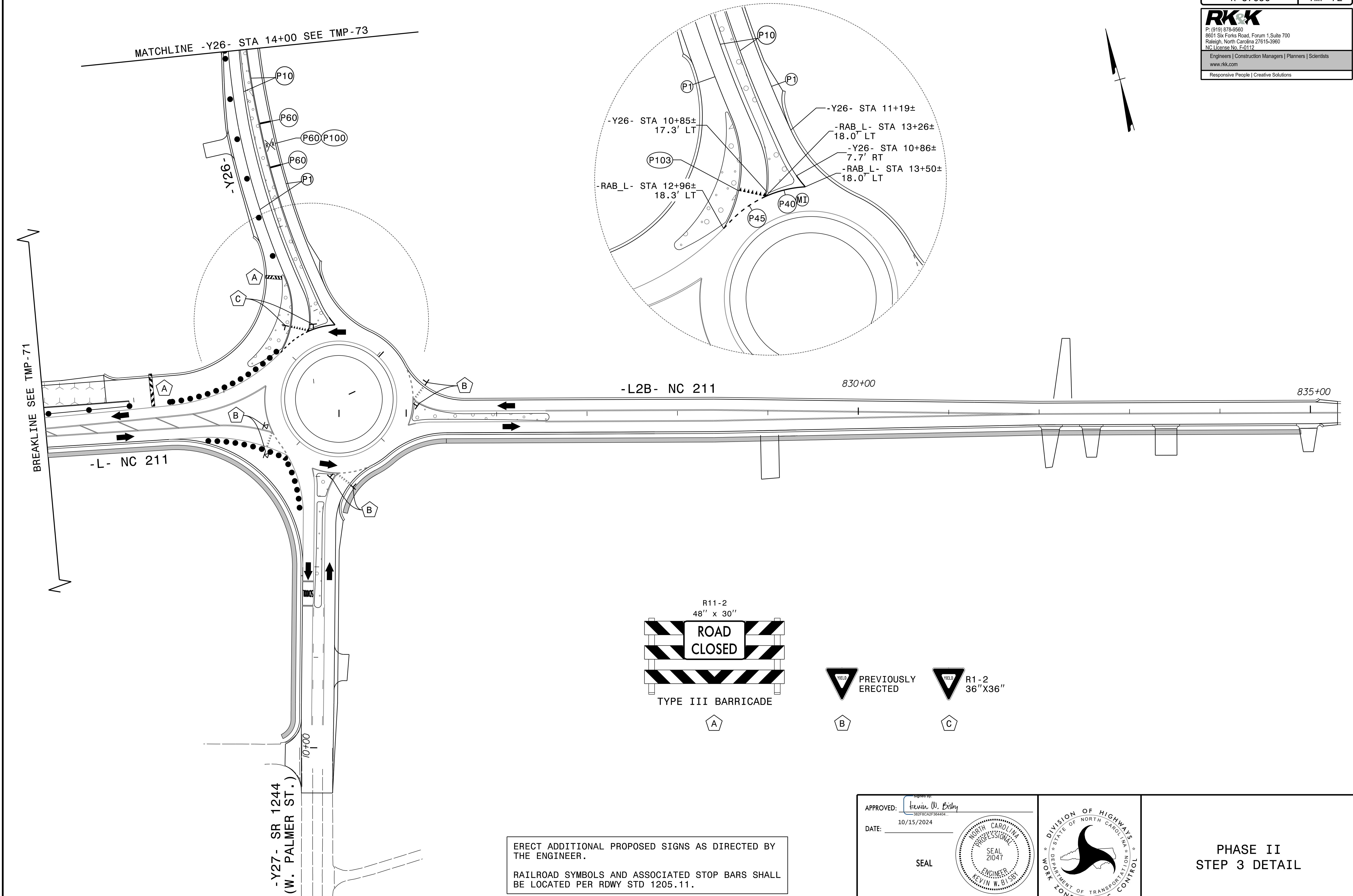

ERECT ADDITIONAL PROPOSED SIGNS AS DIRECTED BY THE ENGINEER.
 RAILROAD SYMBOLS AND ASSOCIATED STOP BARS SHALL BE LOCATED PER RDWY STD 1205.11.

APPROVED: *Kevin W. Bisby*
 DATE: 10/15/2024
 SEAL

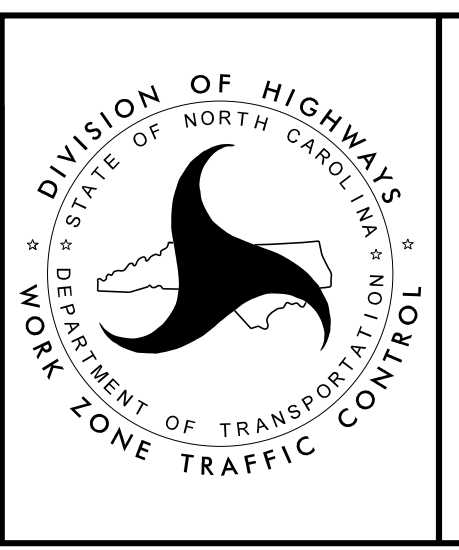

PHASE II
 STEP 3 DETAIL

8/28/2024
 RST05_TMP_psh72.dgn
 Rstebby

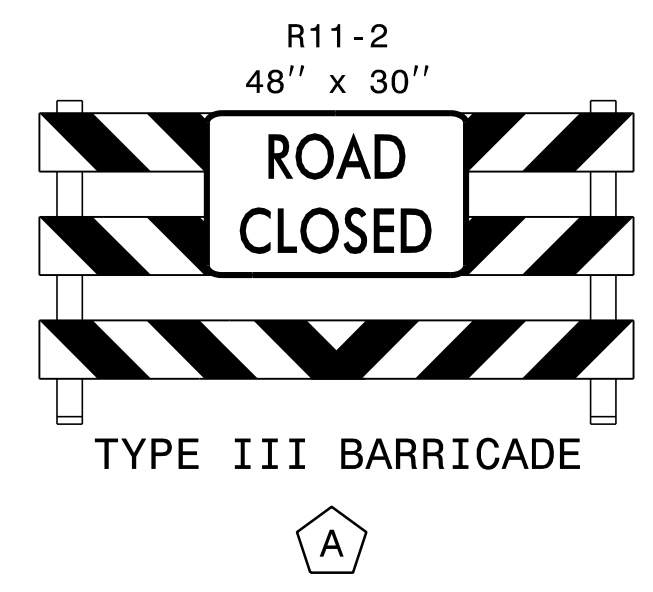
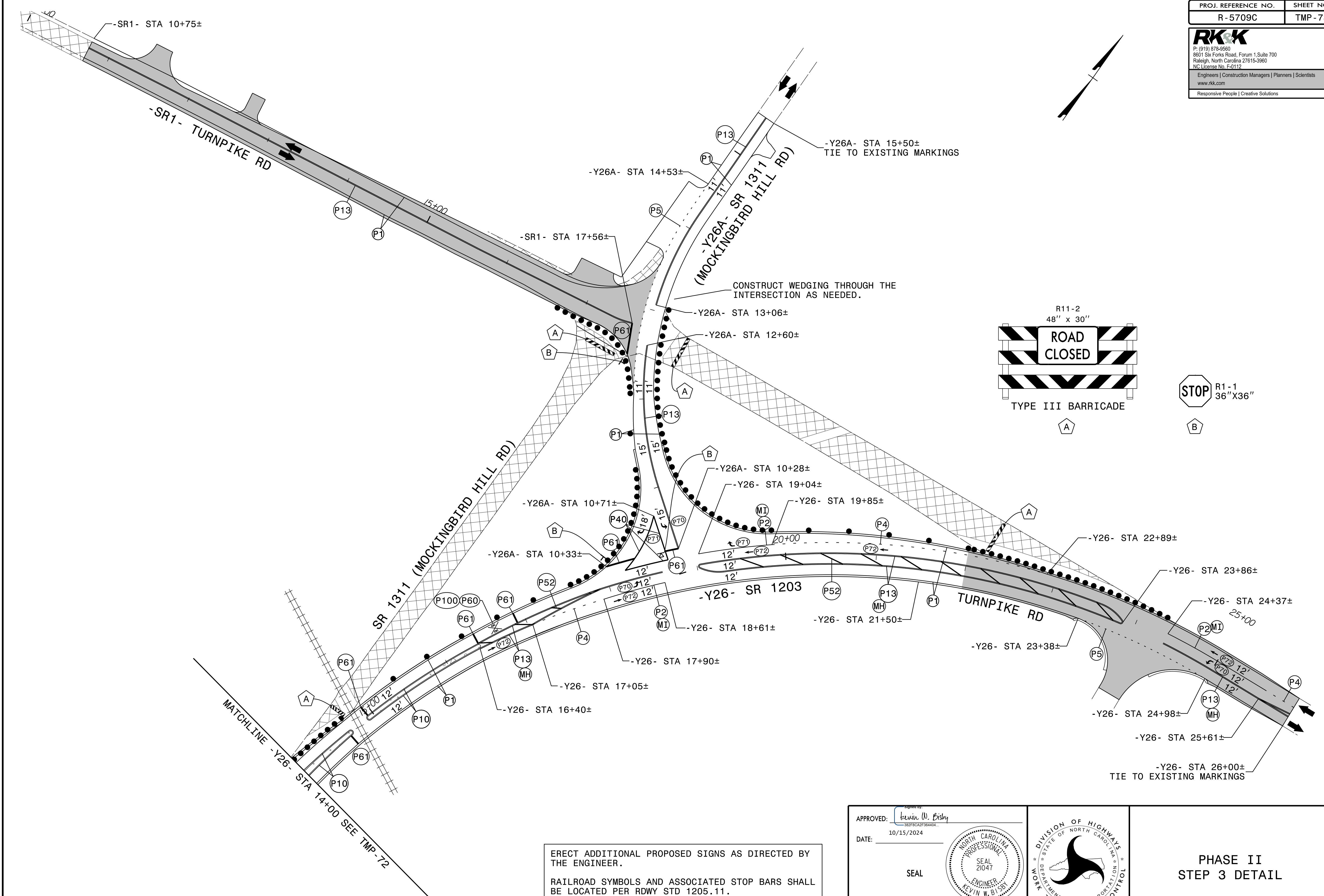

ERECT ADDITIONAL PROPOSED SIGNS AS DIRECTED BY THE ENGINEER.
 RAILROAD SYMBOLS AND ASSOCIATED STOP BARS SHALL BE LOCATED PER RDWY STD 1205.11.

APPROVED: *Kevin W. Bisby*
 DATE: 10/15/2024

SEAL

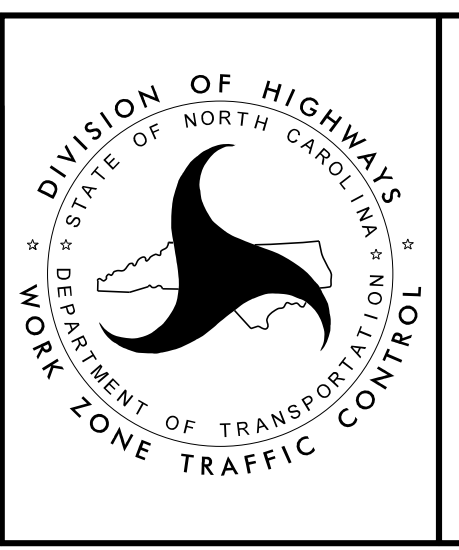

PHASE II
 STEP 3 DETAIL

8/28/2024
 RST05_TMP-psht73.dgn
 Rolsby

PROJ. REFERENCE NO.	SHEET NO.
R-5709C	TMP-74

RKK
 P: (919) 878-8560
 8601 Six Forks Road, Forum 1, Suite 700
 Raleigh, North Carolina 27615-3960
 NC License No. F-0112
 Engineers | Construction Managers | Planners | Scientists
 www.rkk.com
 Responsive People | Creative Solutions

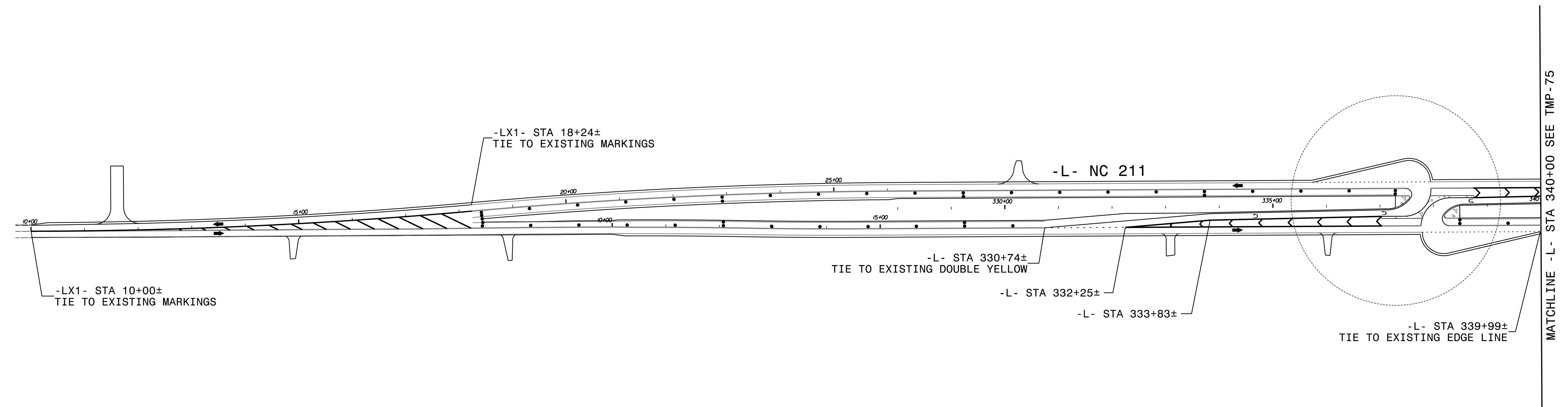
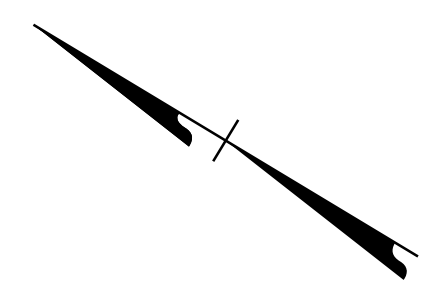

12' LANES
 ERECT PROPOSED SIGNING AS APPLICABLE
 SEE TMP-74A FOR ADDITIONAL PAVEMENT MARKING INFORMATION.

APPROVED: *Kevin W. Bisby*
182F8CA2F364404
 DATE: 10/15/2024

SEAL

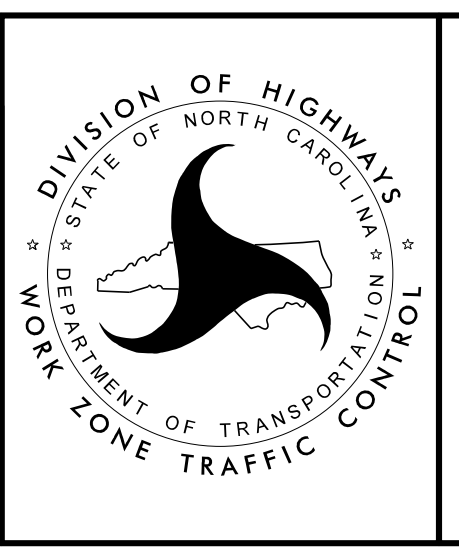

PHASE III
 STEP 1 DETAILS

8/28/2024
 RST05_TMP_PSH74.dgn
 RStebby

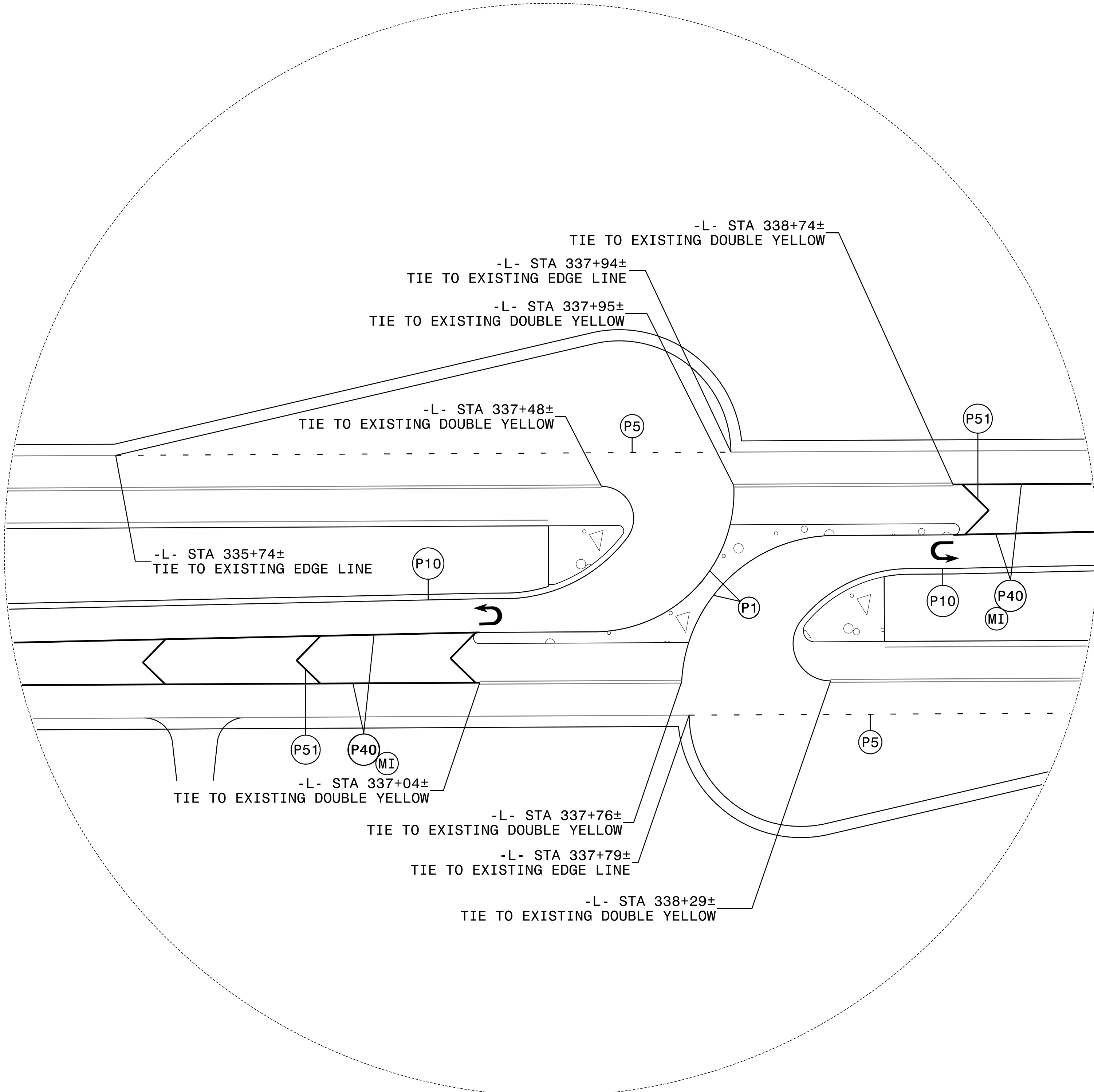

8/28/2024
RST05_TMP_PSH74A.dgn
Rolsby

APPROVED: *Kevin W. Bisby*
382P8CA2P384404

DATE: 10/15/2024

SEAL

**DOCUMENT NOT CONSIDERED FINAL
UNLESS ALL SIGNATURES COMPLETED**

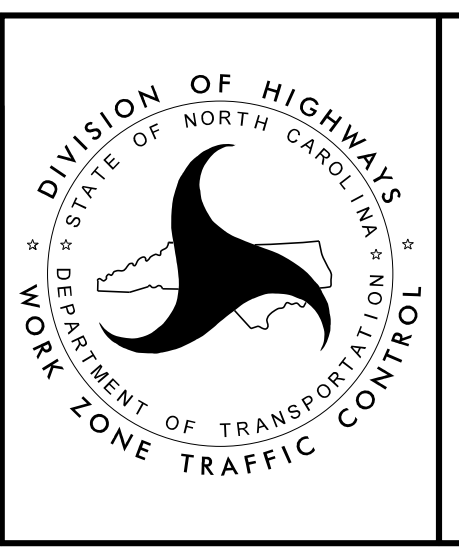

**PHASE III
STEP 1 DETAILS**

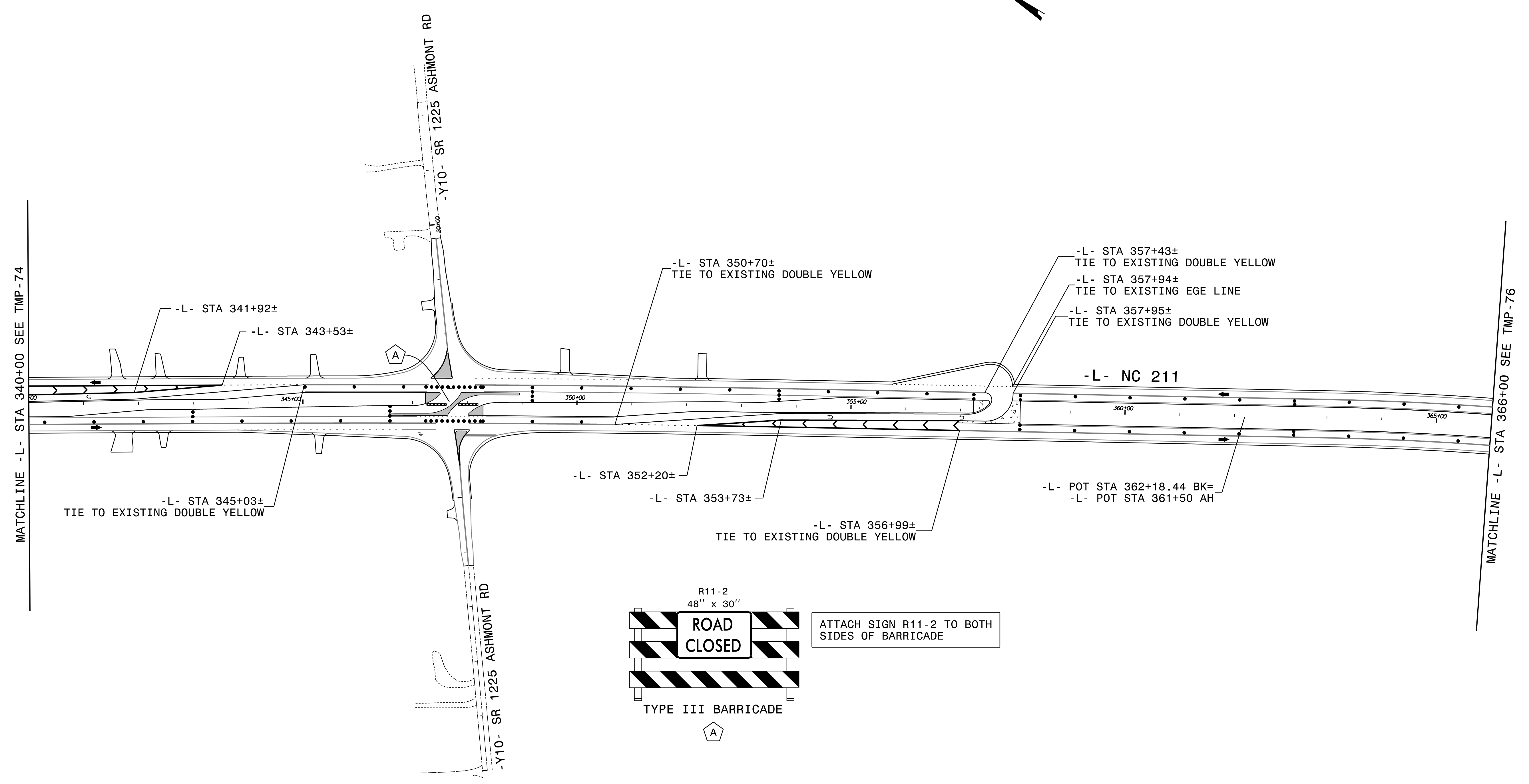

8/28/2024
 RST05_TMP_PSH75.dgn
 Rolsby

APPROVED: Kevin W. Bisby
362P8CA2P364404

DATE: 10/15/2024

SEAL

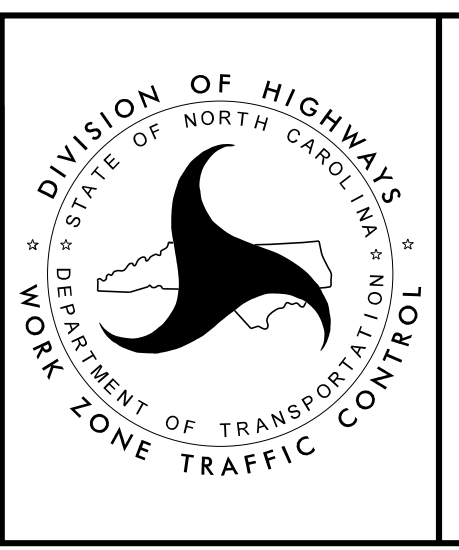

**PHASE III
 STEP 1 DETAILS**

12' LANES
 ERECT PROPOSED SIGNING AS APPLICABLE

**DOCUMENT NOT CONSIDERED FINAL
 UNLESS ALL SIGNATURES COMPLETED**

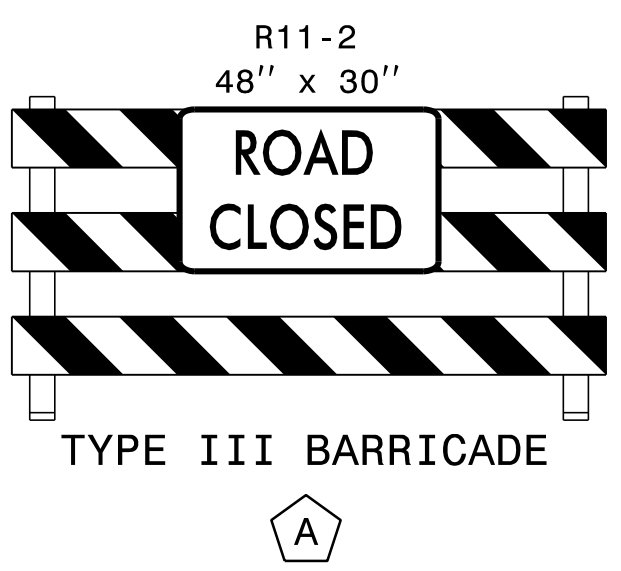
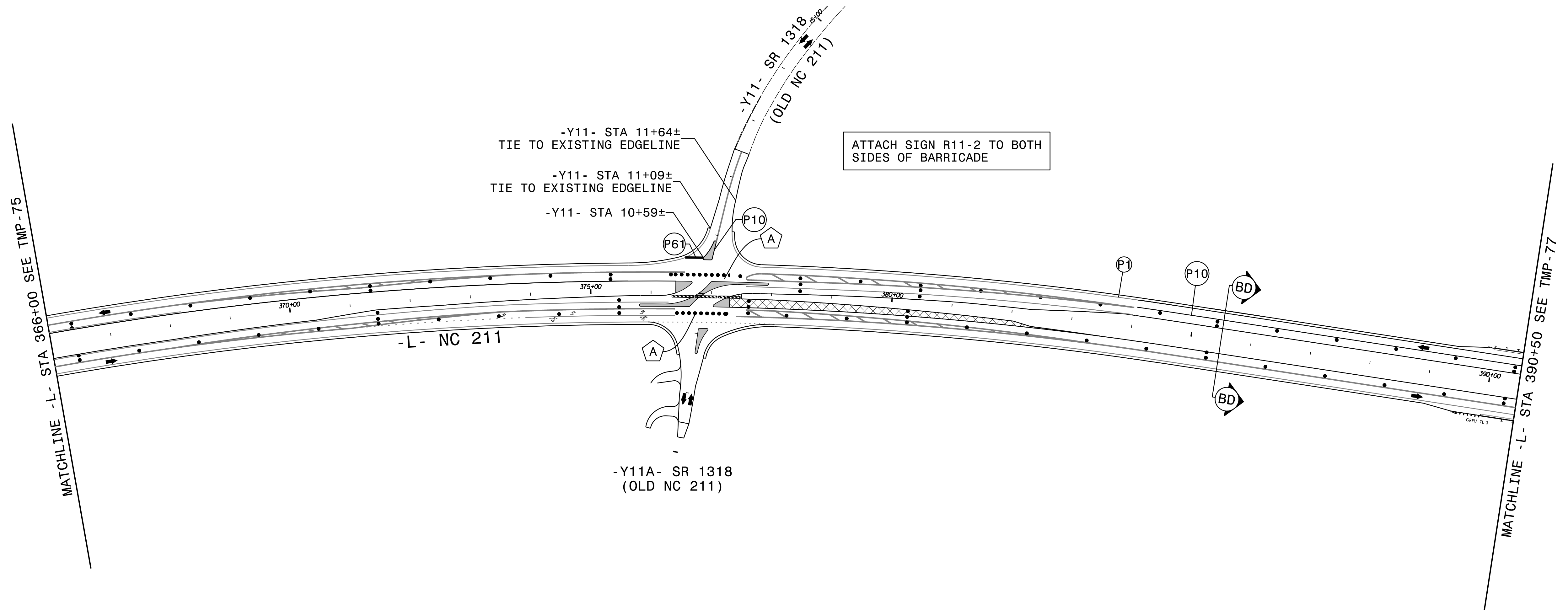
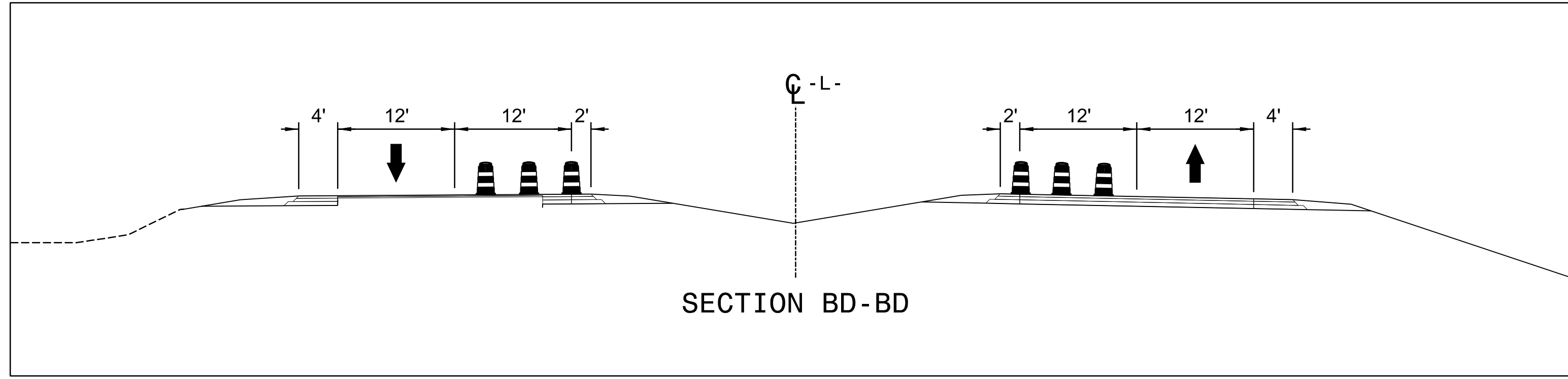

ERECT PROPOSED SIGNING AS APPLICABLE.
12' LANES

APPROVED: *Kevin W. Bisby*
382P8CA2P384404
 DATE: 10/15/2024

SEAL

PHASE III
STEP 1 DETAILS

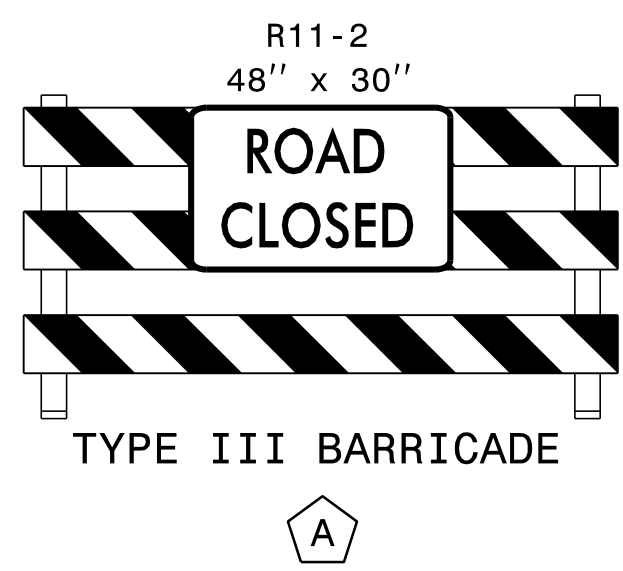
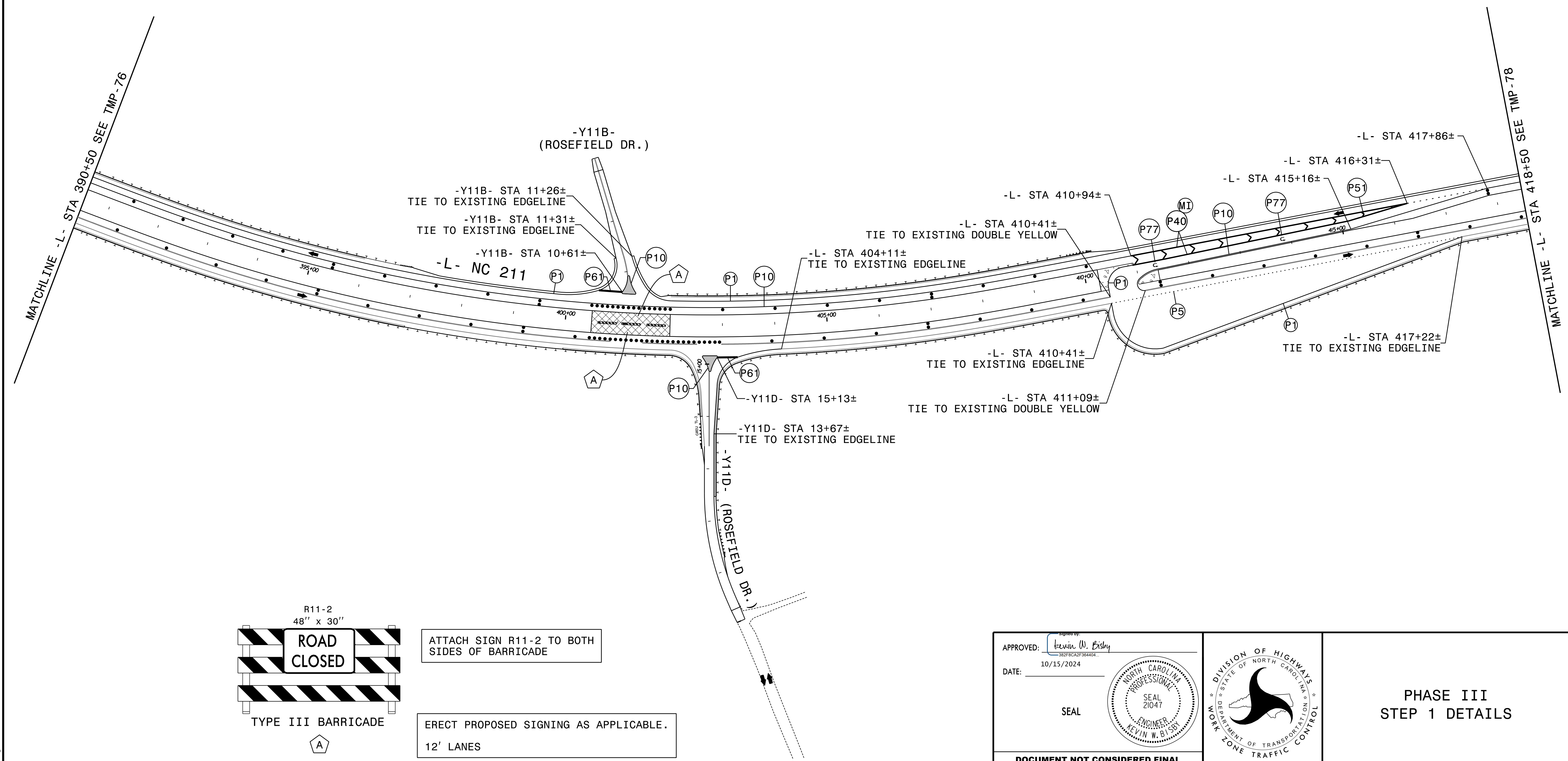
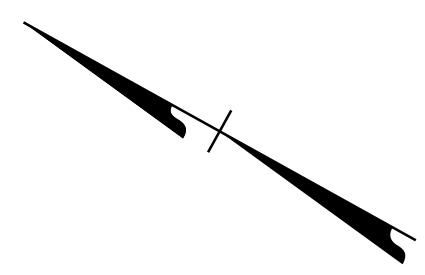

ATTACH SIGN R11-2 TO BOTH SIDES OF BARRICADE

ERECT PROPOSED SIGNING AS APPLICABLE.
 12' LANES

APPROVED: Kevin W. Bisby
382F8CA2F364404
 DATE: 10/15/2024

SEAL

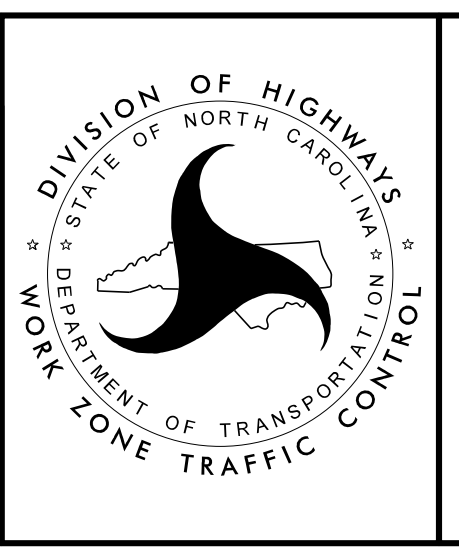

PHASE III
 STEP 1 DETAILS

8/28/2024
 R5105_TMP_psh77.dgn
 Rolsby

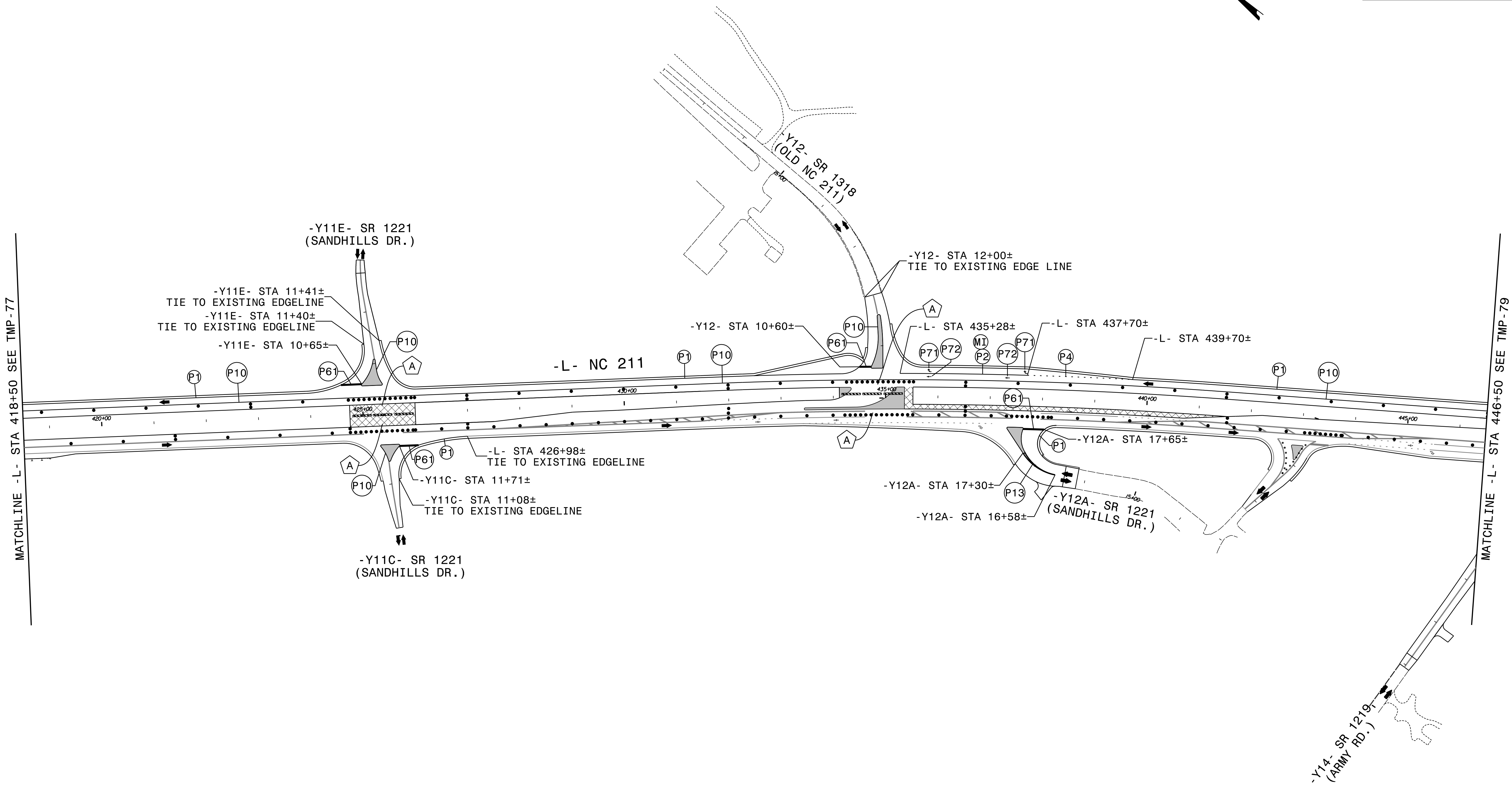
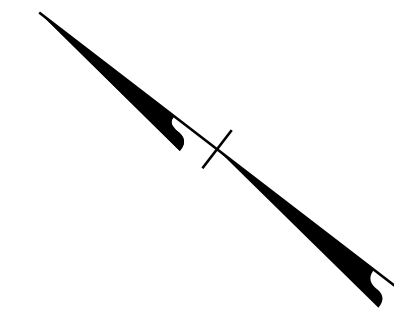

ATTACH SIGN R11-2 TO BOTH SIDES OF BARRICADE

ERECT PROPOSED SIGNING AS APPLICABLE.
12' LANES

APPROVED: Kevin W. Bisby
182F8CA2F364404

DATE: 10/15/2024

SEAL

**DOCUMENT NOT CONSIDERED FINAL
UNLESS ALL SIGNATURES COMPLETED**

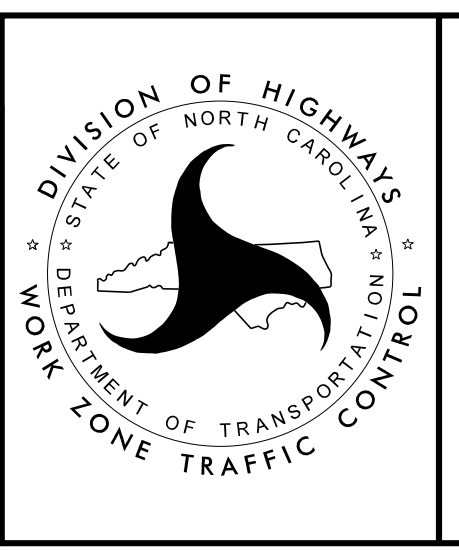

PHASE III
STEP 1 DETAILS

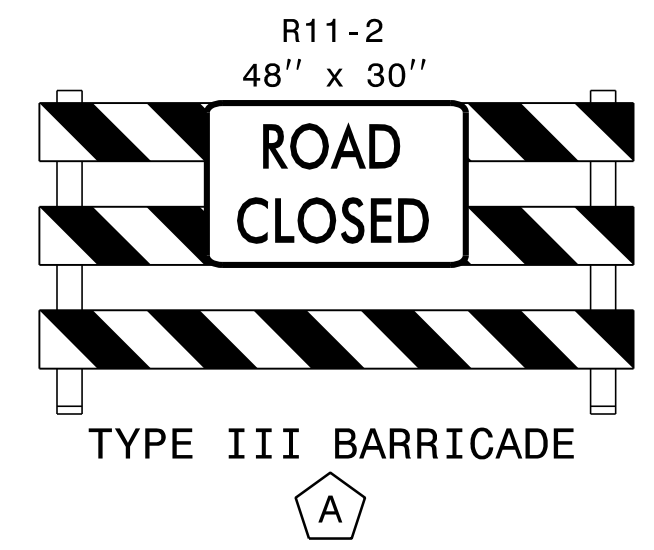
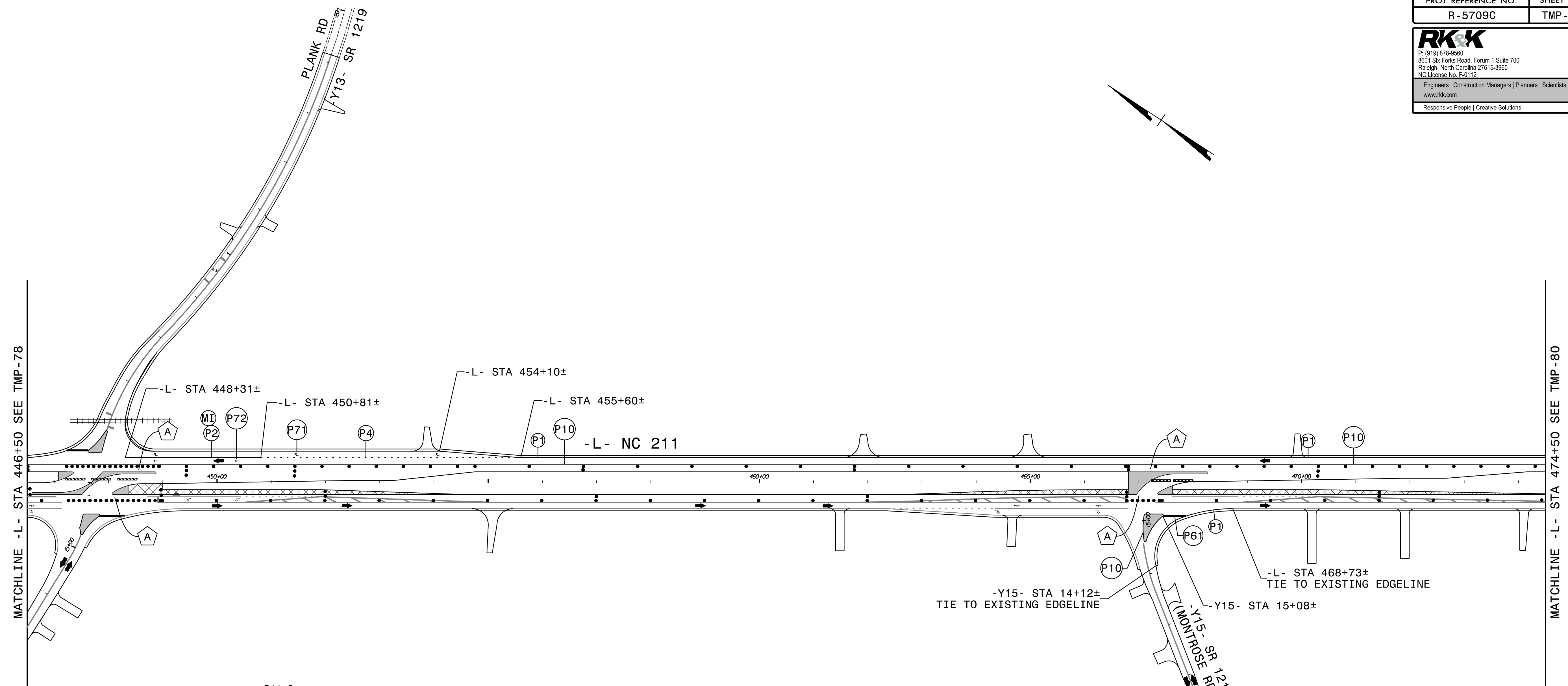

ATTACH SIGN R11-2 TO BOTH SIDES OF BARRICADE

ERECT PROPOSED SIGNING AS APPLICABLE.
 12' LANES

APPROVED: *Kevin W. Bisby*
18298CA2P384404
 DATE: 10/15/2024

SEAL

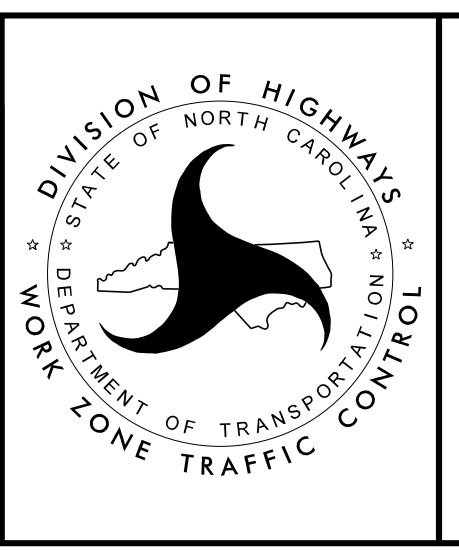

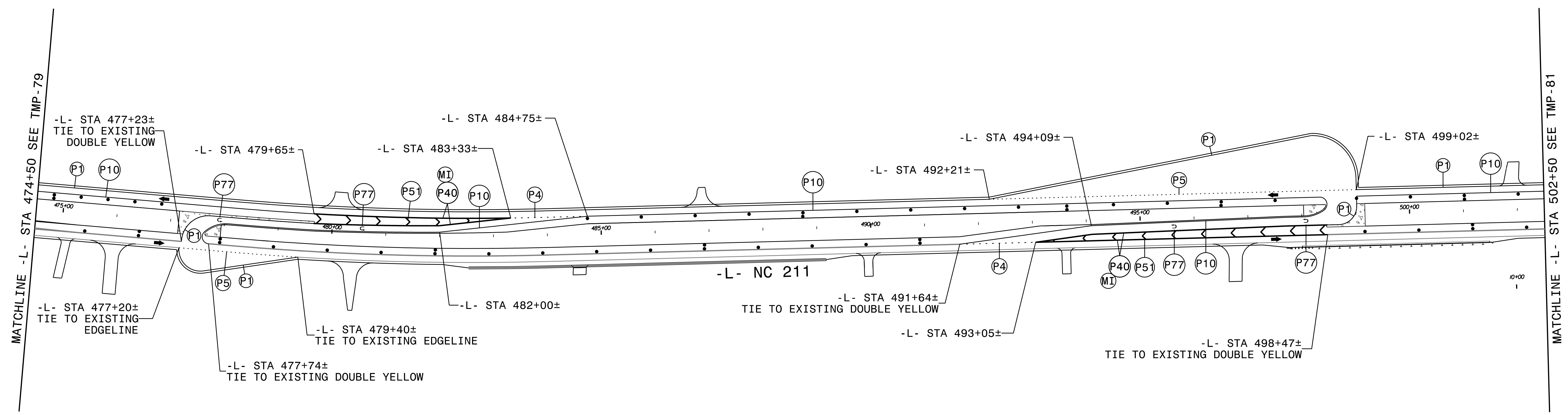
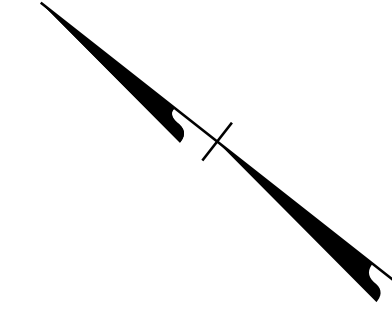

PHASE III
 STEP 1 DETAILS

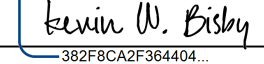
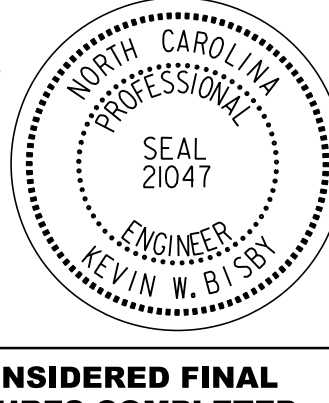

8/28/2024
 R5105_TMP_psh80.dgn
 Rolsby

ERECT PROPOSED SIGNING AS APPLICABLE.
 12' LANES

APPROVED:  DATE: 10/15/2024 SEAL 		<p>PHASE III STEP 1 DETAILS</p>
<p>DOCUMENT NOT CONSIDERED FINAL UNLESS ALL SIGNATURES COMPLETED</p>		

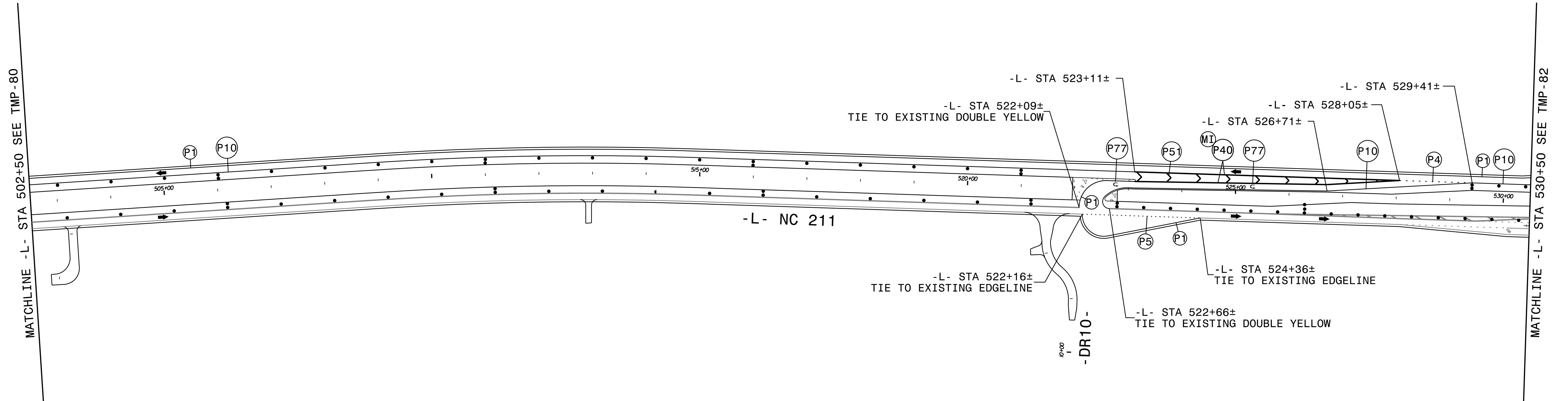
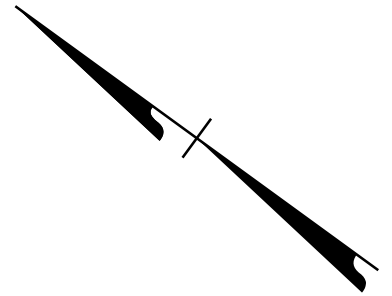

PROJ. REFERENCE NO.	SHEET NO.
R-5709C	TMP-81

RKK
 P: (919) 878-8560
 8601 Six Forks Road, Forum 1, Suite 700
 Raleigh, North Carolina 27615-3960
 NC License No. F-0112
 Engineers | Construction Managers | Planners | Scientists
 www.rkk.com
 Responsive People | Creative Solutions

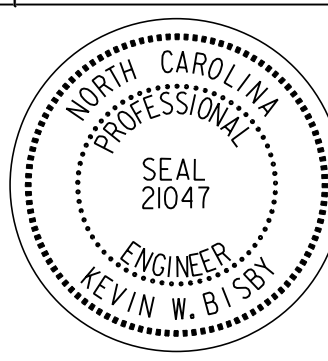

8/28/2024
 R5105_TMP_pshb1.dgn
 R01sby

ERECT PROPOSED SIGNING AS APPLICABLE.
 12' LANES

<p>APPROVED: <i>Kevin W. Bisby</i> <small>18298CA2P384404</small></p> <p>DATE: 10/15/2024</p> <p>SEAL</p> 		<p>PHASE III STEP 1 DETAILS</p>
<p>DOCUMENT NOT CONSIDERED FINAL UNLESS ALL SIGNATURES COMPLETED</p>		

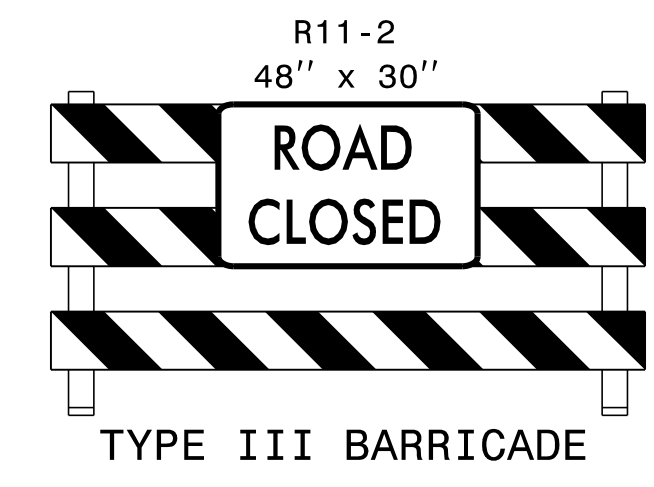
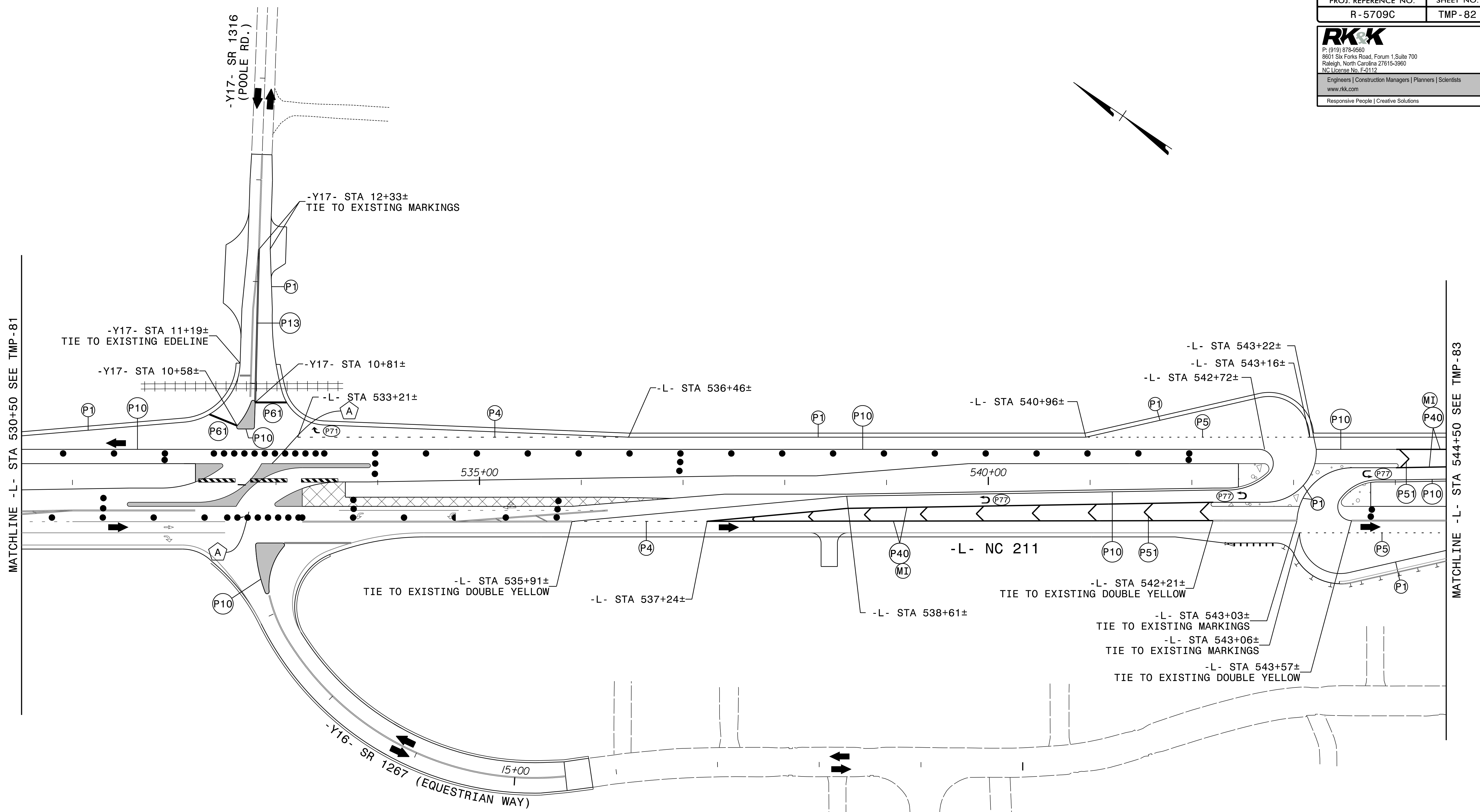

ATTACH SIGN R11-2 TO BOTH SIDES OF BARRICADE

ERECT PROPOSED SIGNING AS APPLICABLE.
12' LANES

APPROVED: *Kevin W. Bisby*
38298CA2P384404
 DATE: 10/15/2024
 SEAL

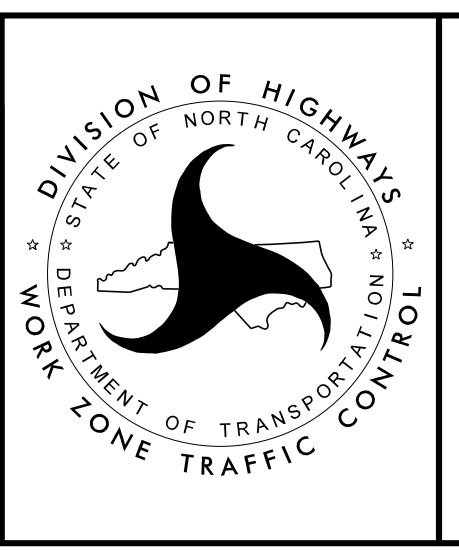

PHASE III
STEP 1 DETAILS

8/28/2024
R5105_TMP_psh82.dgn
Rolsby

DOCUMENT NOT CONSIDERED FINAL
UNLESS ALL SIGNATURES COMPLETED

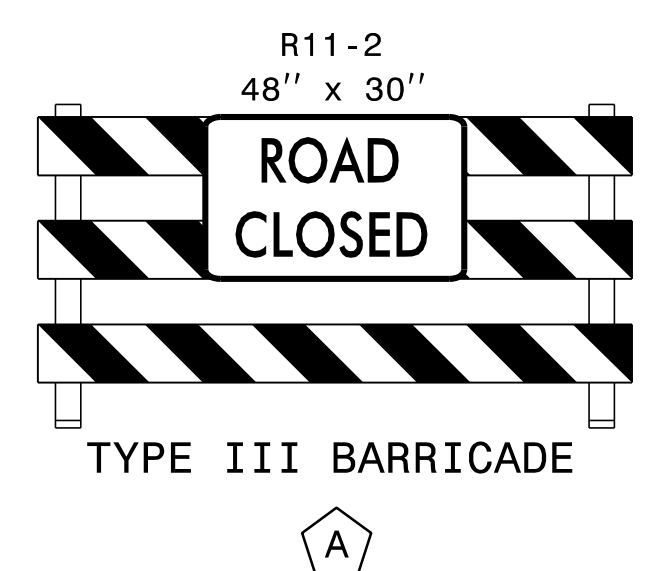
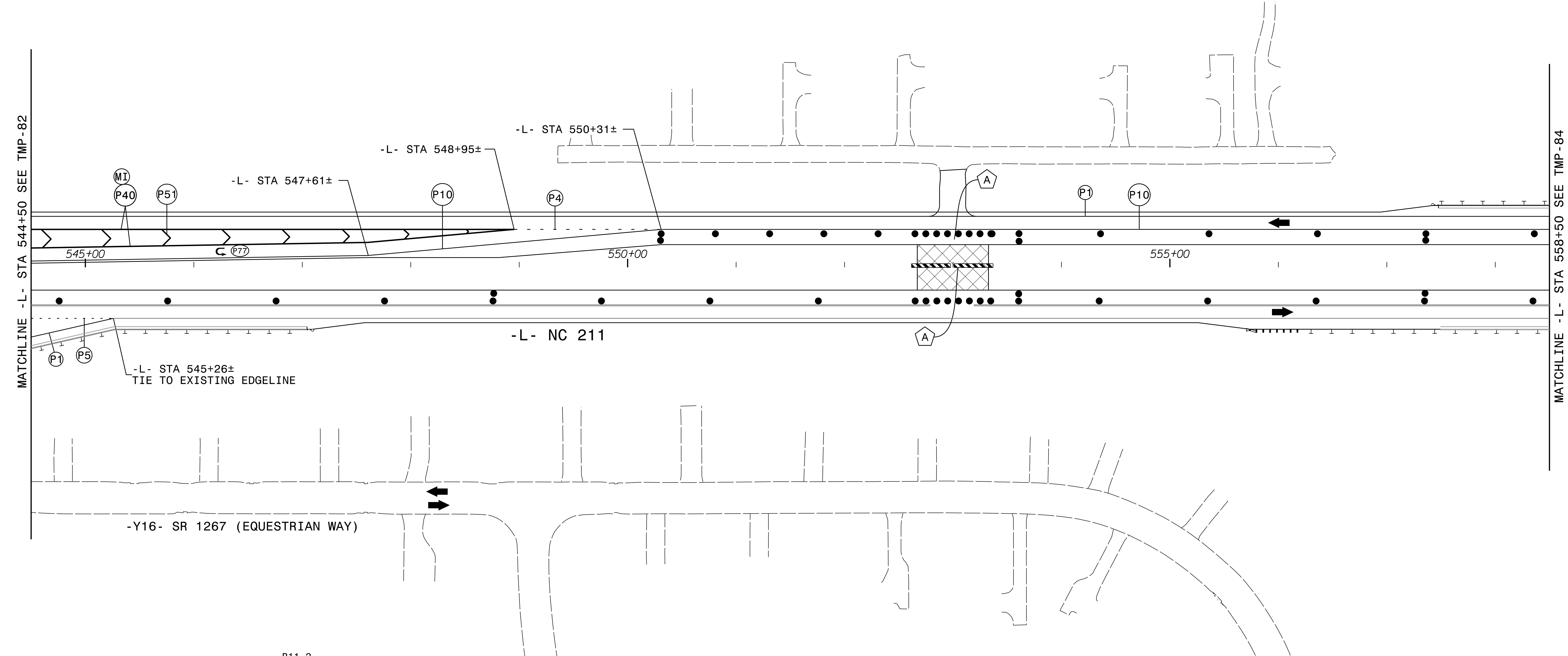
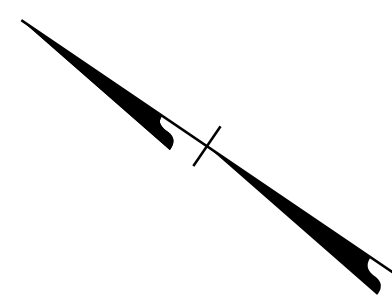

ATTACH SIGN R11-2 TO BOTH SIDES OF BARRICADE

ERECT PROPOSED SIGNING AS APPLICABLE.
 12' LANES

APPROVED: *Kevin W. Bisby*
10/15/2024
 DATE: 10/15/2024

SEAL

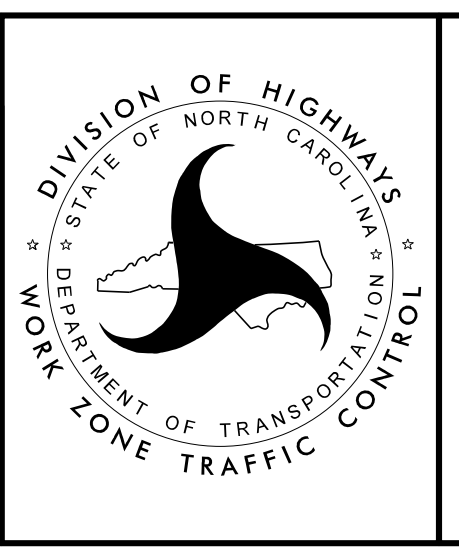

PHASE III
 STEP 1 DETAILS

8/28/2024
 R-5709C_TMP-psht83.dgn
 Rolsby

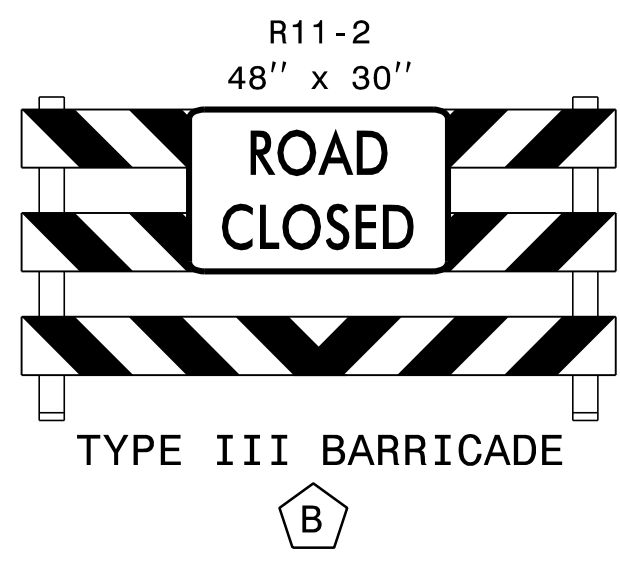
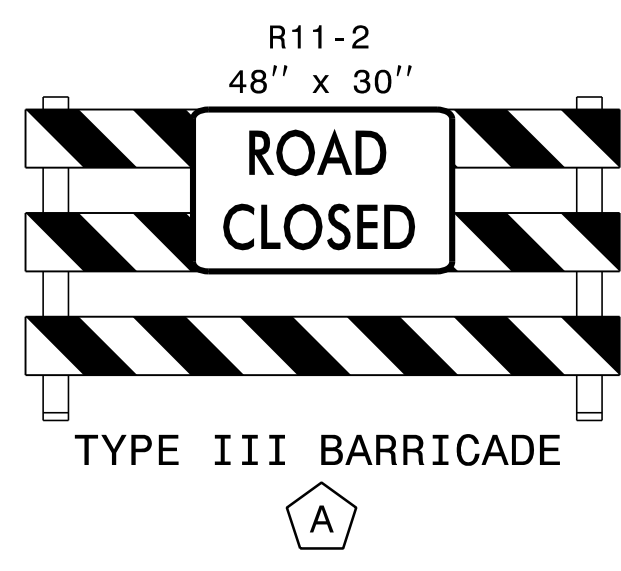
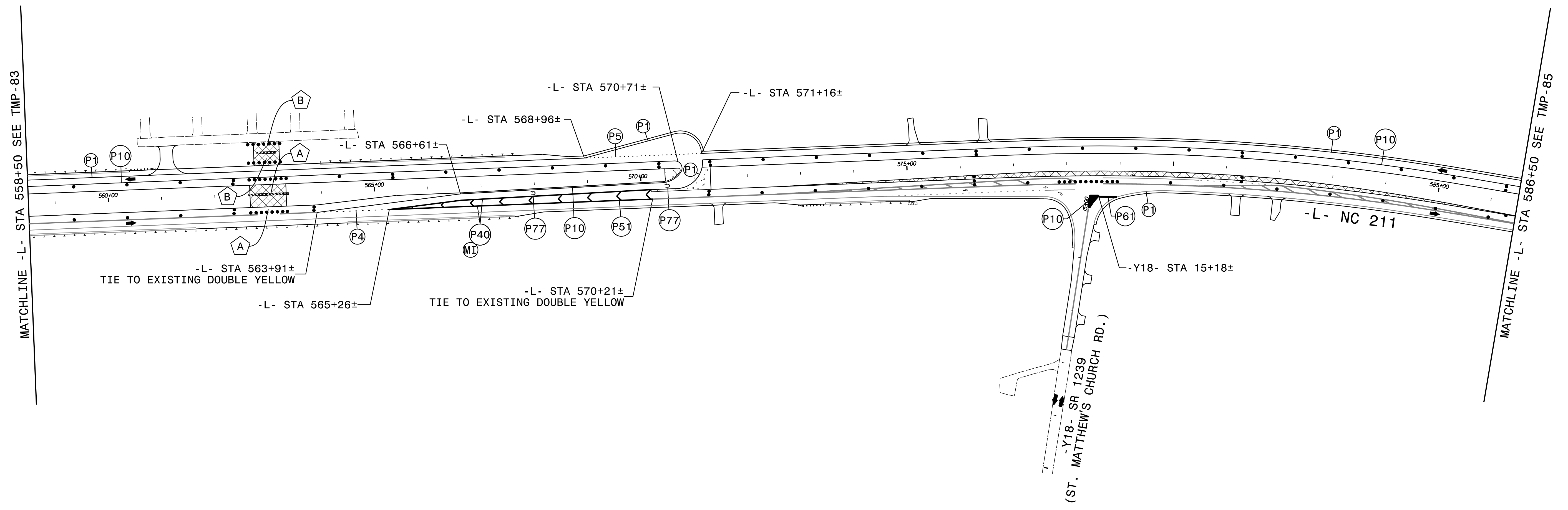
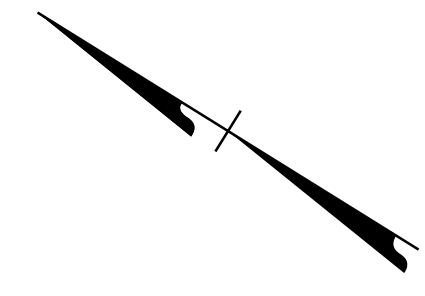

ATTACH SIGN R11-2 TO BOTH SIDES OF BARRICADE

ERECT PROPOSED SIGNING AS APPLICABLE.
12' LANES

APPROVED: Kevin W. Bisby
382P0CA2P384404

DATE: 10/15/2024

SEAL

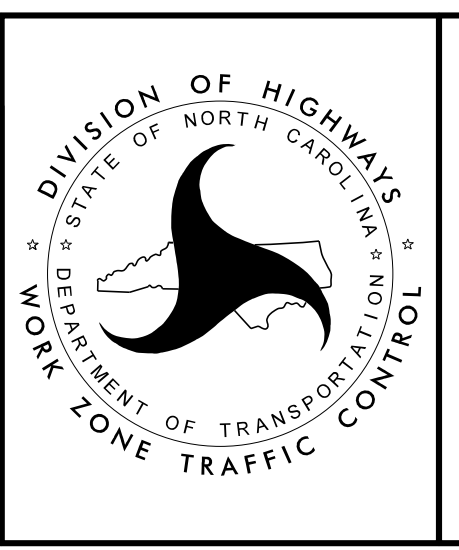

PHASE III
STEP 1 DETAILS

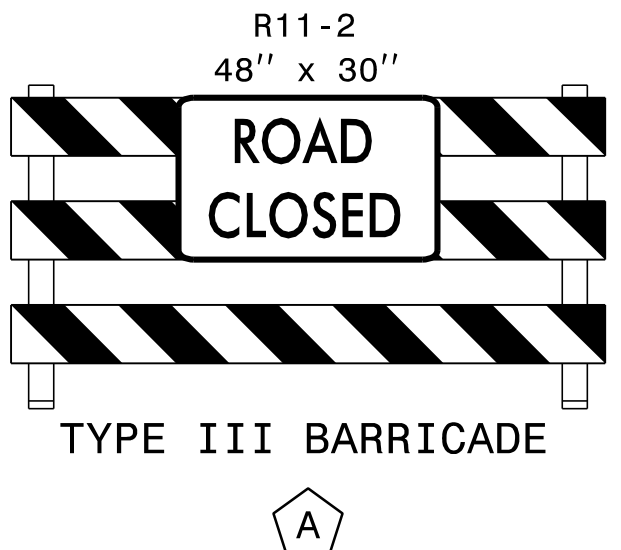
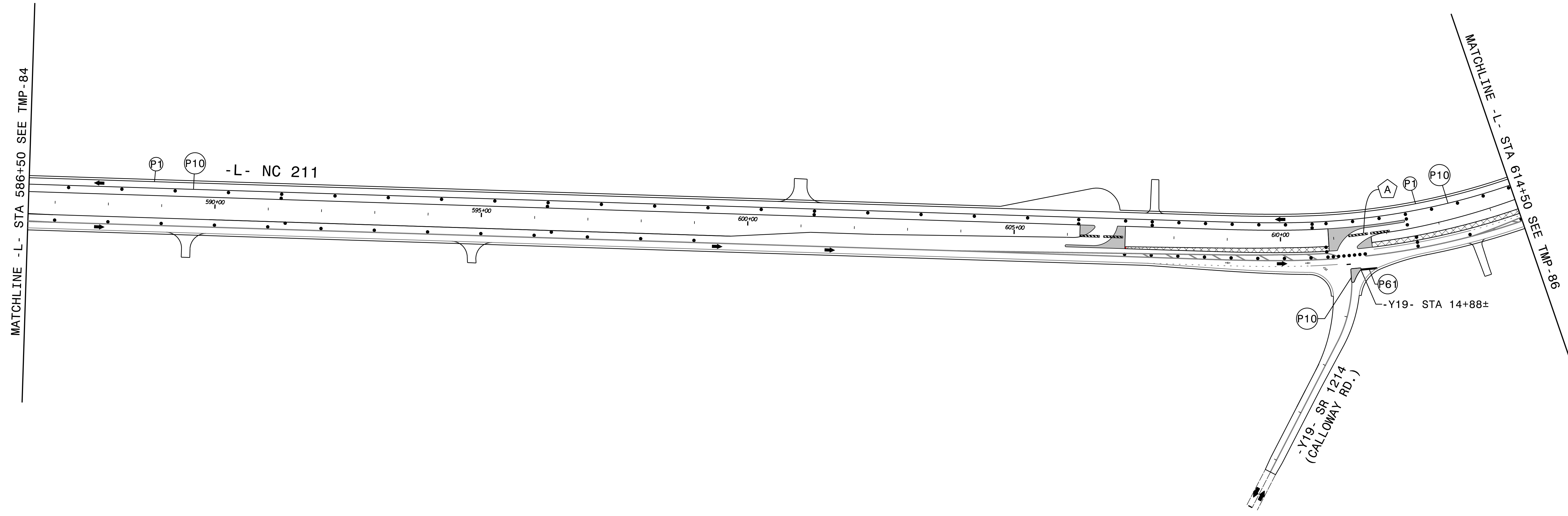
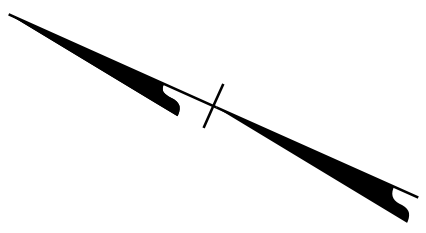

ATTACH SIGN R11-2 TO BOTH SIDES OF BARRICADE

ERECT PROPOSED SIGNING AS APPLICABLE.
12' LANES

APPROVED: *Kevin W. Bisby*
38298CA2P364404

DATE: 10/15/2024

SEAL

**DOCUMENT NOT CONSIDERED FINAL
UNLESS ALL SIGNATURES COMPLETED**

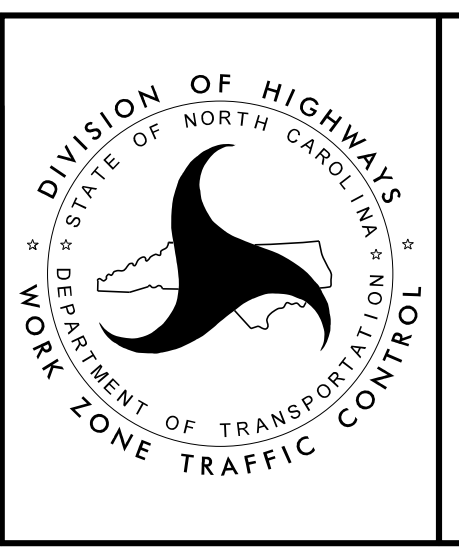

PHASE III
STEP 1 DETAILS

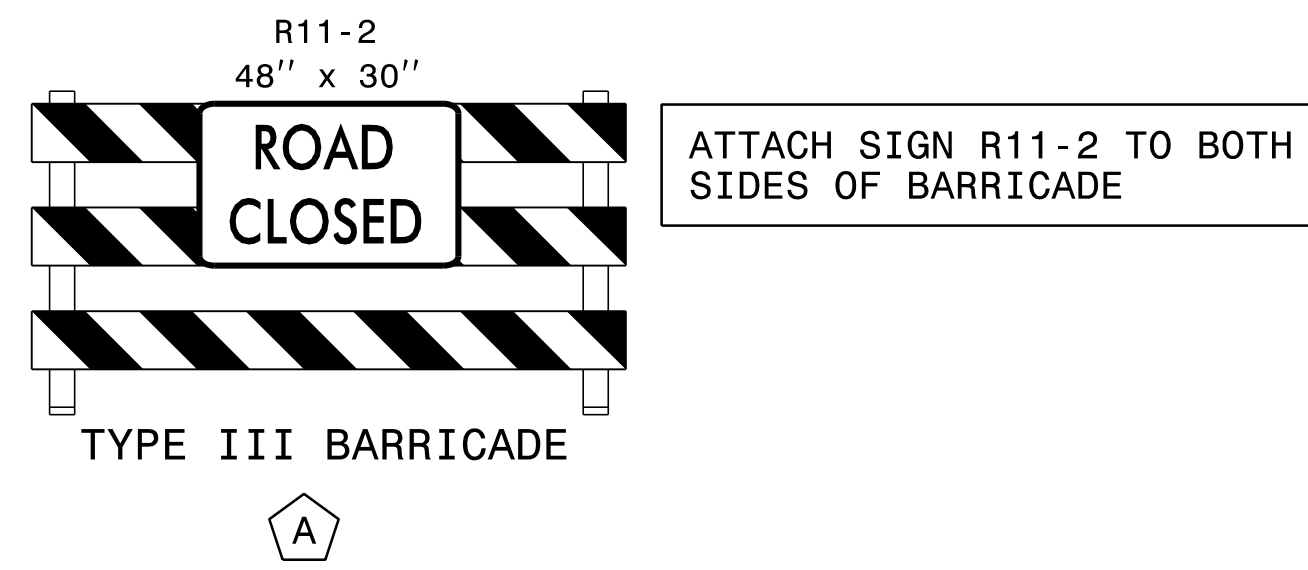
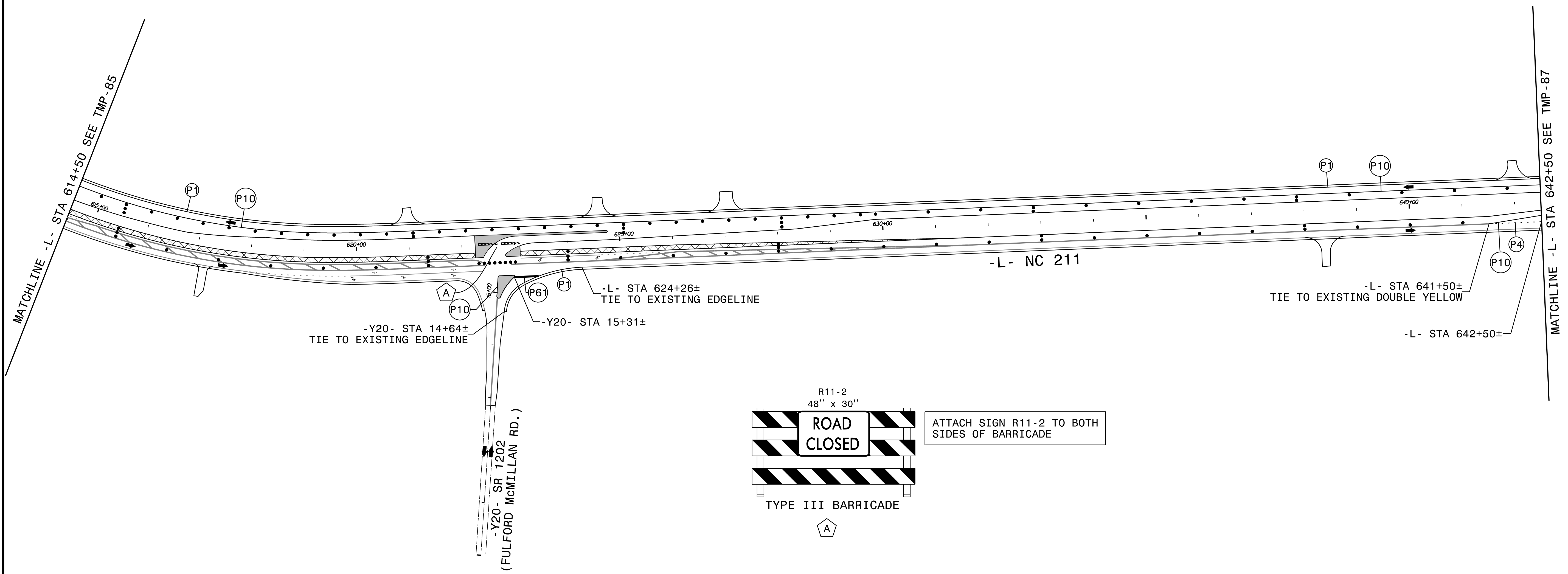
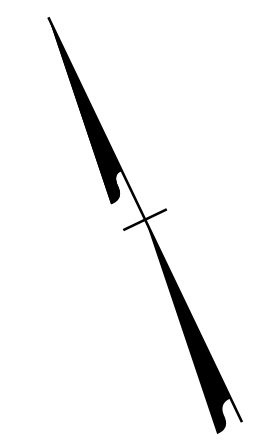

ERECT PROPOSED SIGNING AS APPLICABLE.
 12' LANES

APPROVED: Kevin W. Bisby
182F8CA2F364404

DATE: 10/15/2024

SEAL

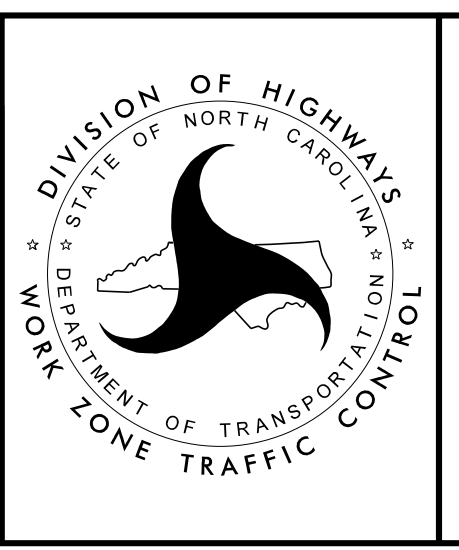

PHASE III
 STEP 1 DETAILS

8/28/2024
 R-5709C_TMP-psht86.dgn
 Robby

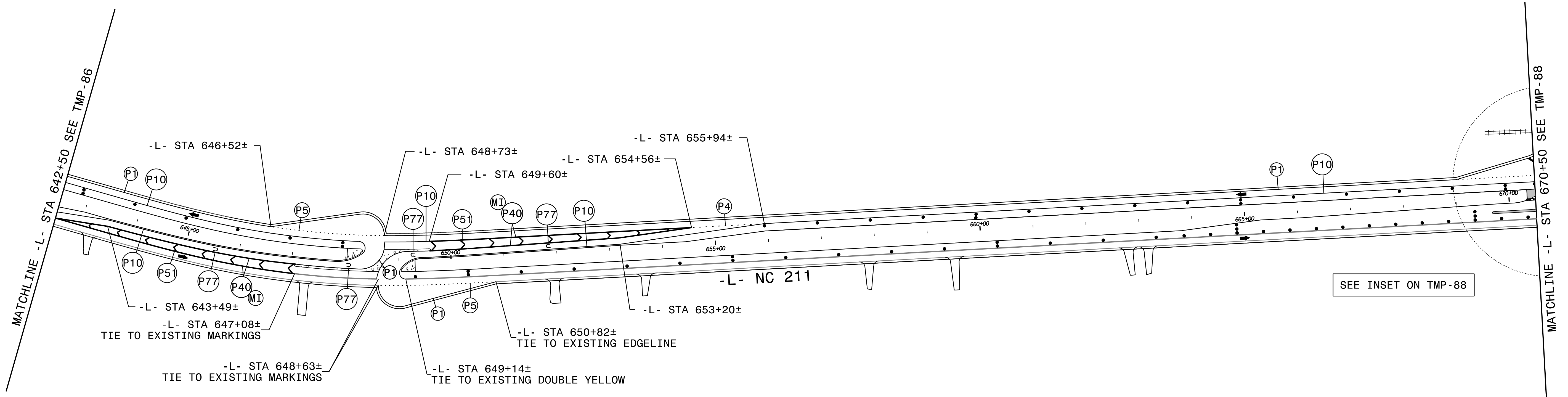

8/28/2024
 RST05_TMP_psh87.dgn
 RStebby

ERECT PROPOSED SIGNING AS APPLICABLE.
 12' LANES

APPROVED: *Kevin W. Bisby*
18298CA2P384404
 DATE: 10/15/2024

SEAL

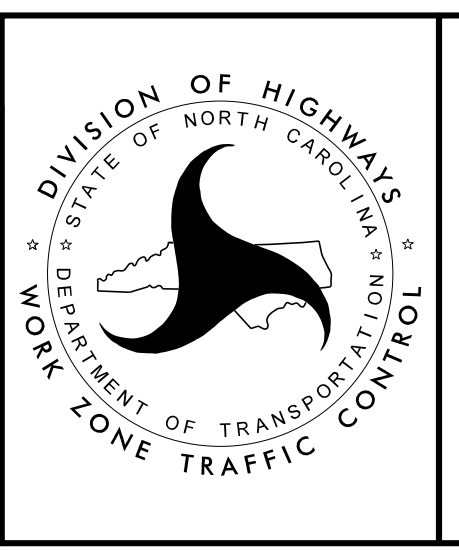

PHASE III
 STEP 1 DETAILS

DOCUMENT NOT CONSIDERED FINAL
 UNLESS ALL SIGNATURES COMPLETED

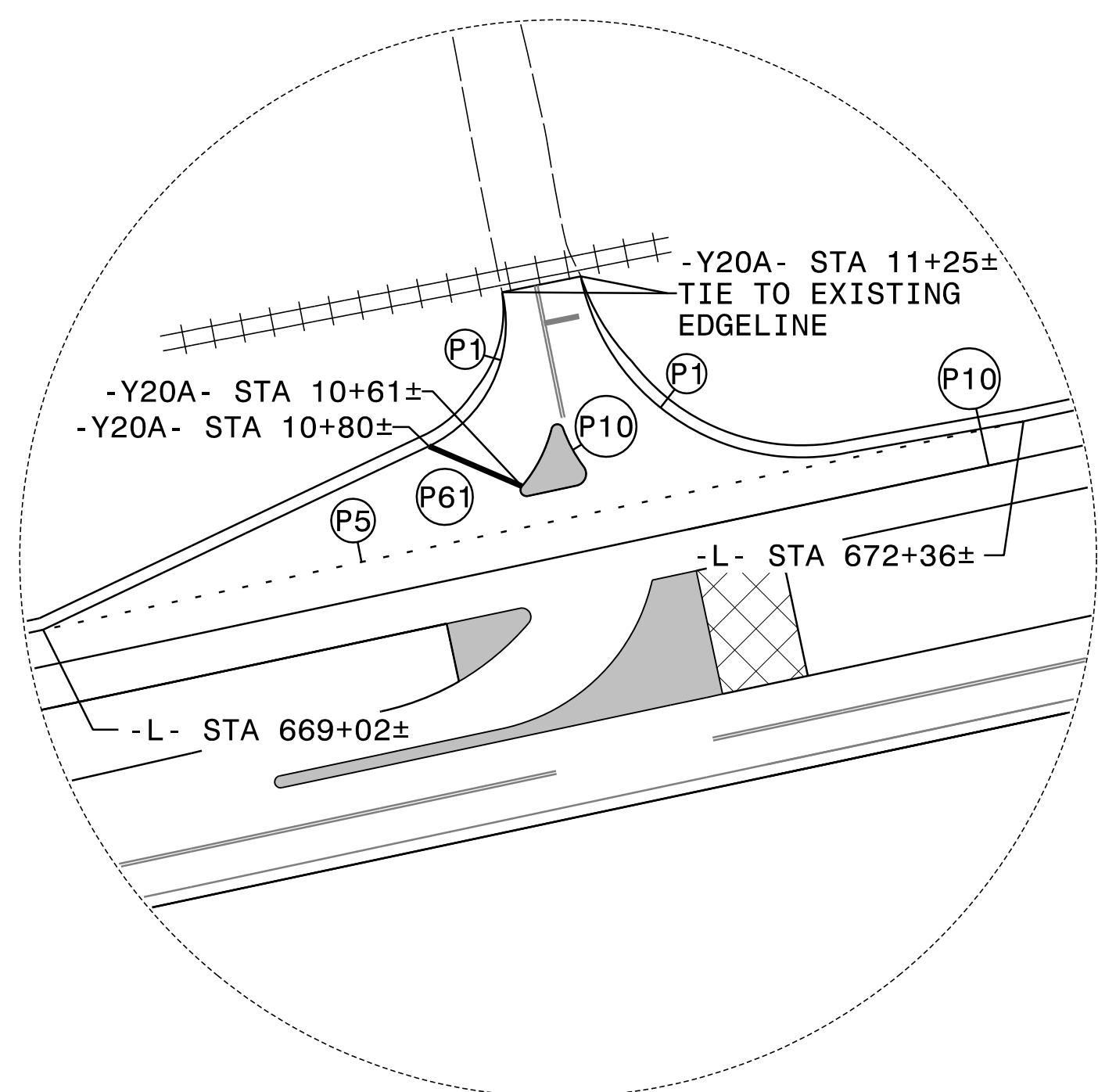
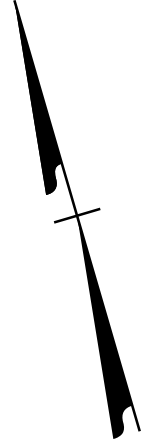

MATCHLINE -L- STA 670+50 SEE TMP-87
 -Y20A-SR1386 (IVEY RD.)

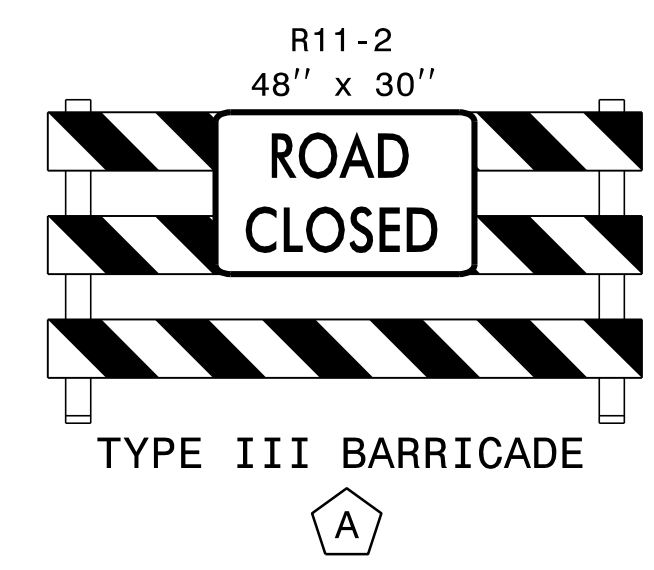
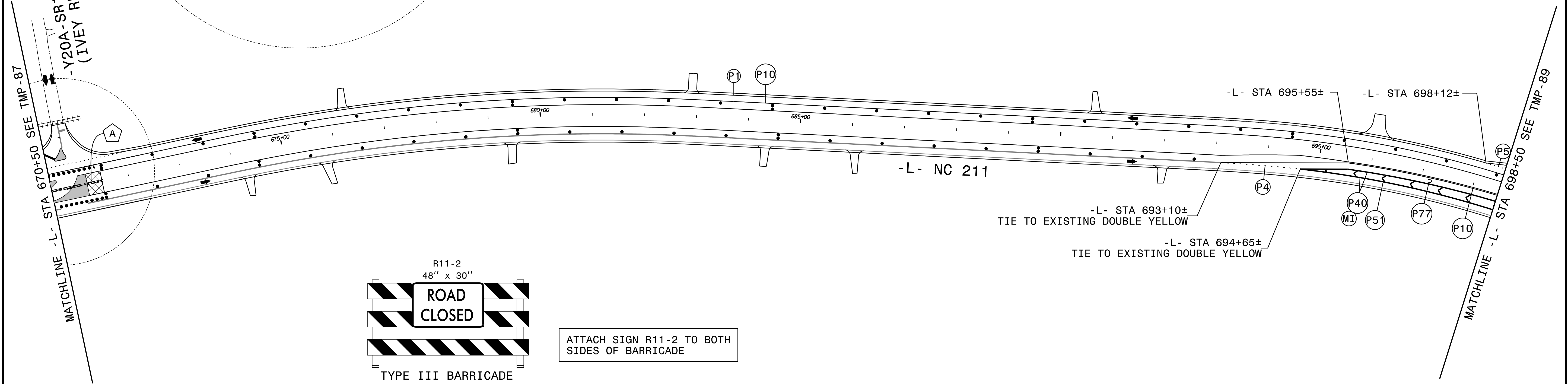

ATTACH SIGN R11-2 TO BOTH SIDES OF BARRICADE

ERECT PROPOSED SIGNING AS APPLICABLE.
12' LANES

APPROVED: *Kevin W. Bisby*
382P8CA2P384404

DATE: 10/15/2024

SEAL

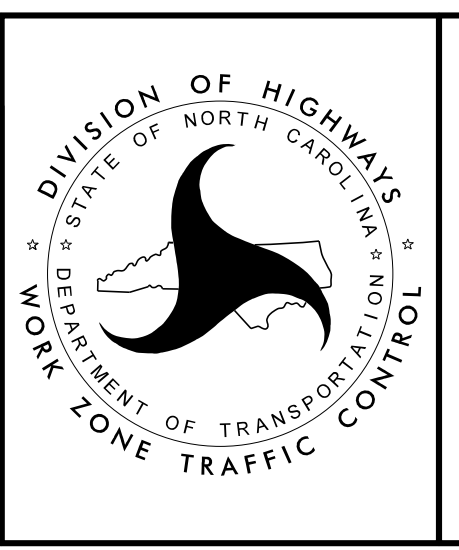

PHASE III
STEP 1 DETAILS

8/28/2024
RST05_TMP_psh88.dgn
Rolsby

DOCUMENT NOT CONSIDERED FINAL
UNLESS ALL SIGNATURES COMPLETED

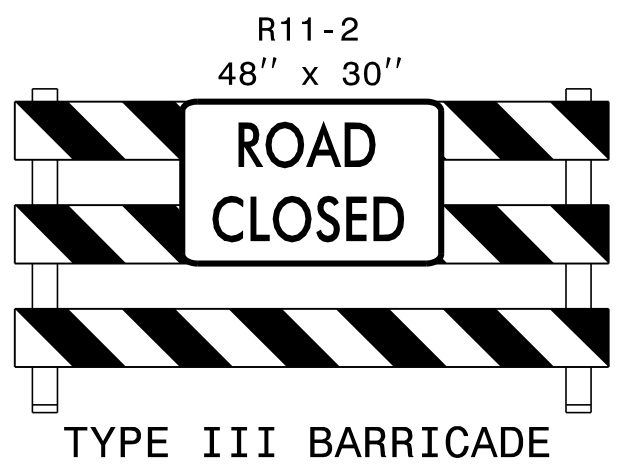
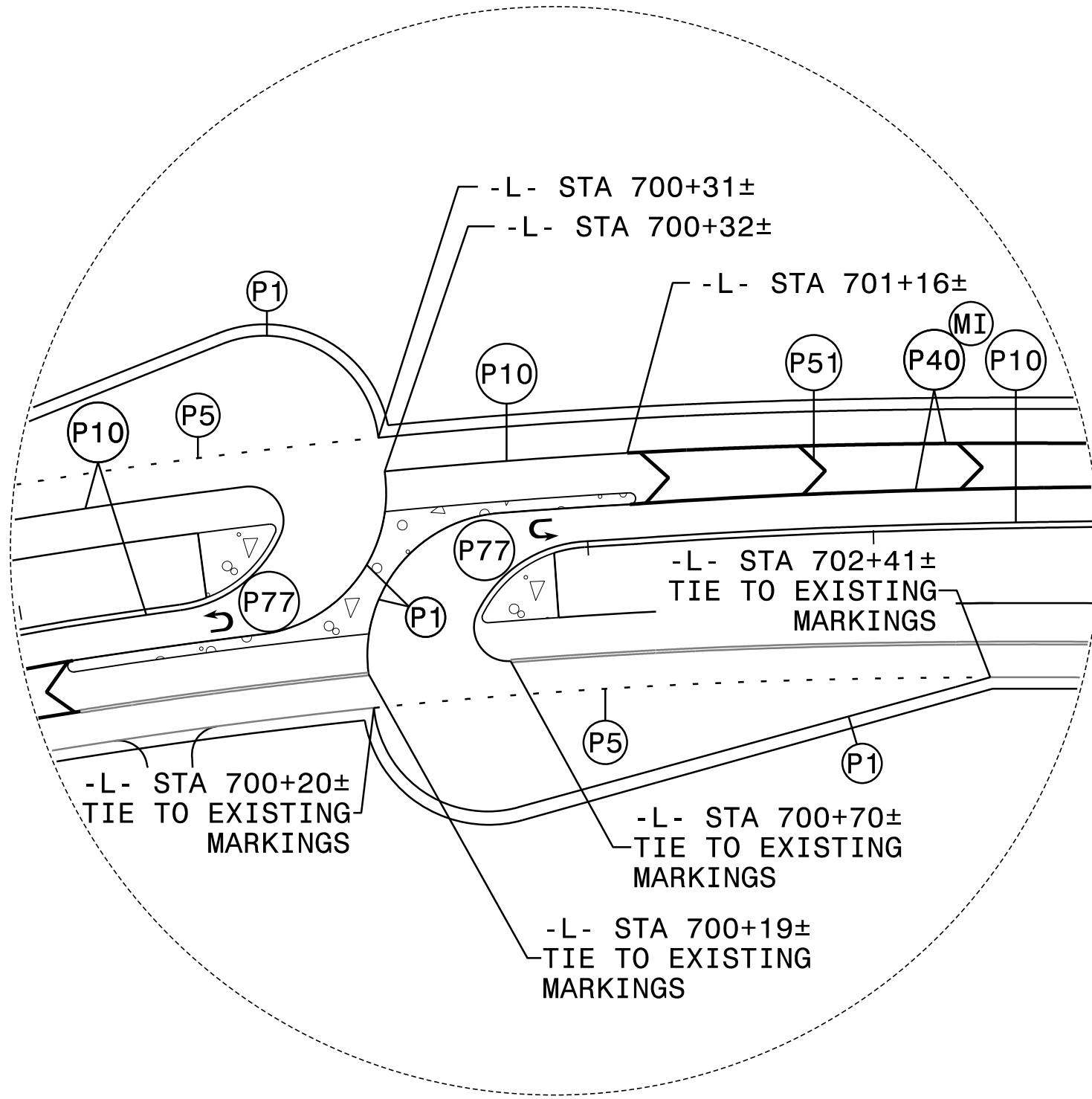
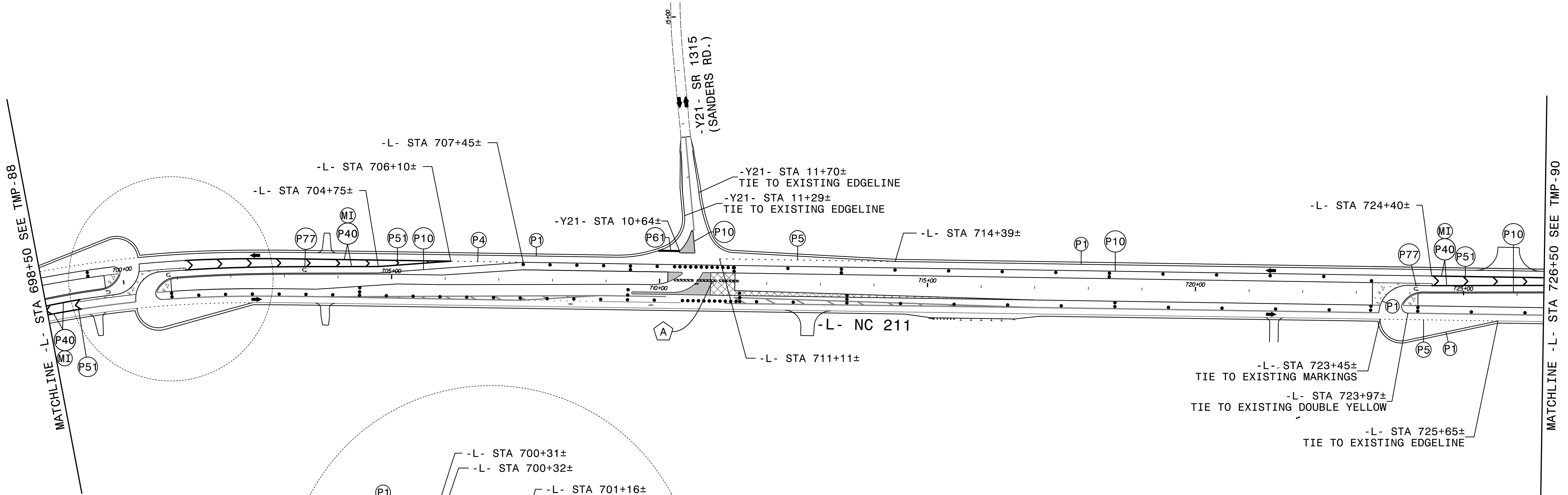
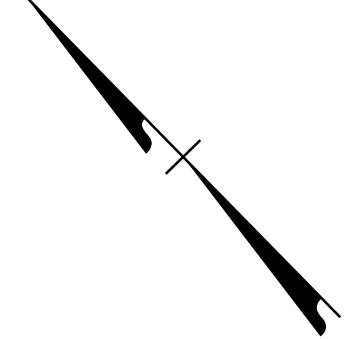

ATTACH SIGN R11-2 TO BOTH SIDES OF BARRICADE

ERECT PROPOSED SIGNING AS APPLICABLE.
 12' LANES

APPROVED: Kevin W. Bisby
36298CA29364404
 DATE: 10/15/2024

SEAL

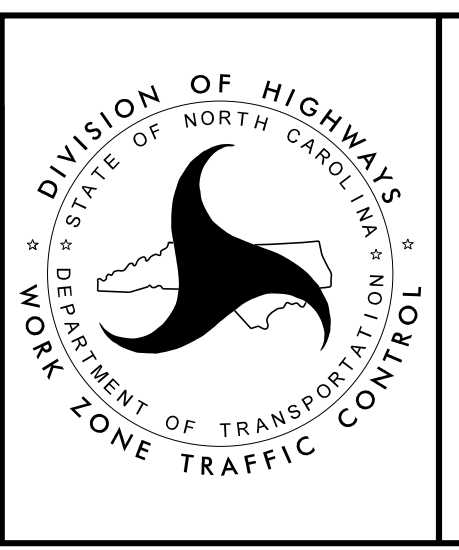

PHASE III
 STEP 1 DETAILS

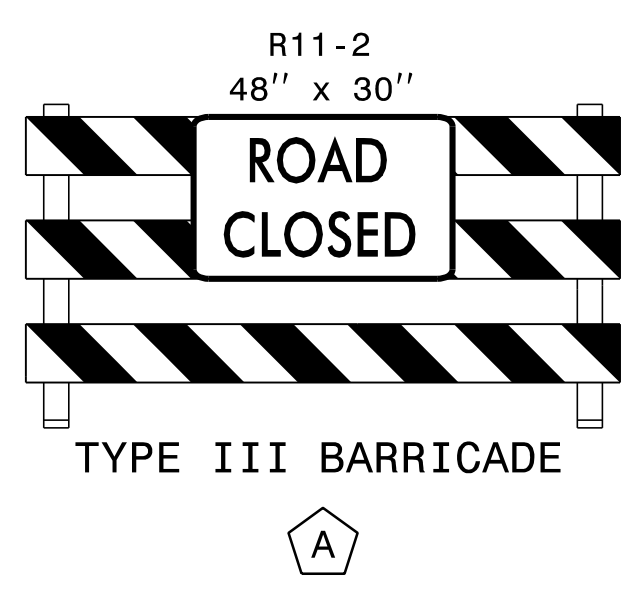
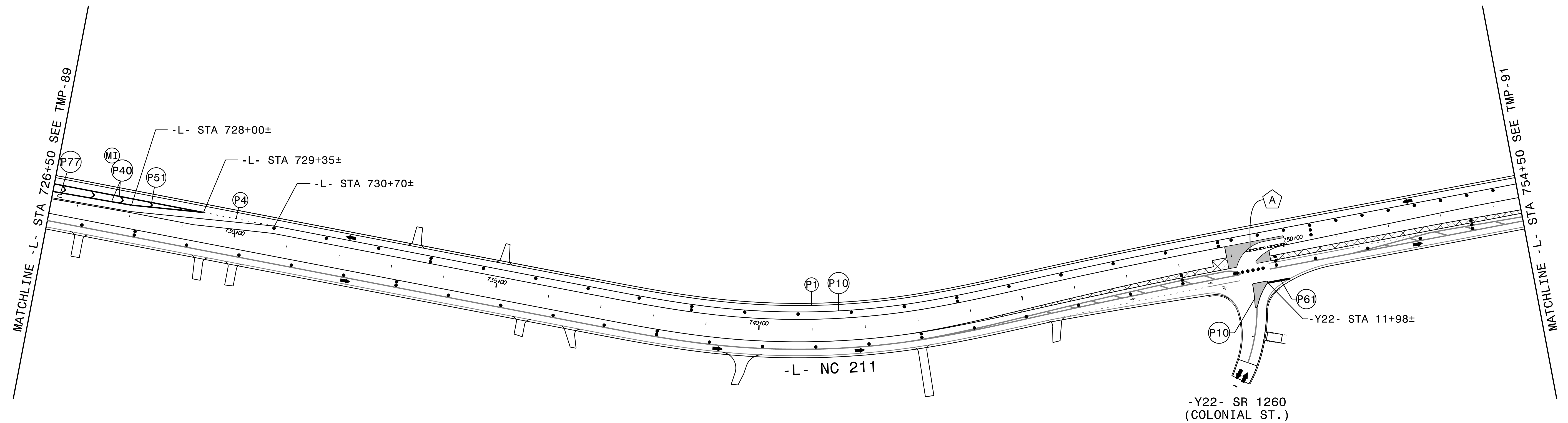
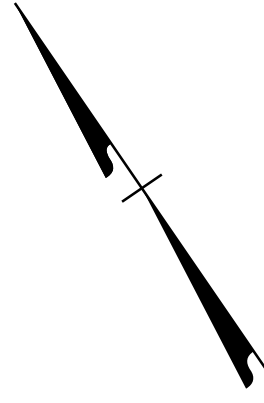

ATTACH SIGN R11-2 TO BOTH SIDES OF BARRICADE

ERECT PROPOSED SIGNING AS APPLICABLE.
12' LANES

APPROVED: *Kevin W. Bisby*
382P8CA2P384404

DATE: 10/15/2024

SEAL

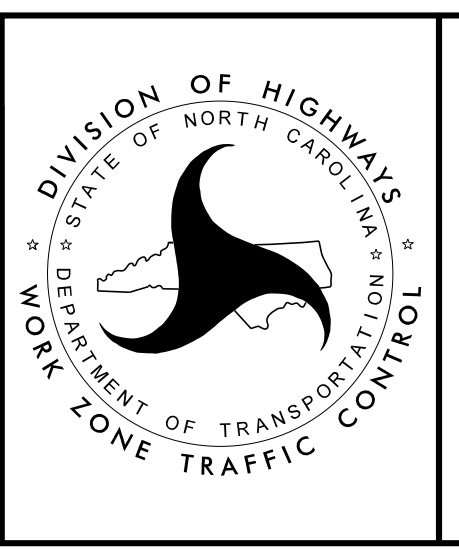

PHASE III
STEP 1 DETAILS

**DOCUMENT NOT CONSIDERED FINAL
UNLESS ALL SIGNATURES COMPLETED**

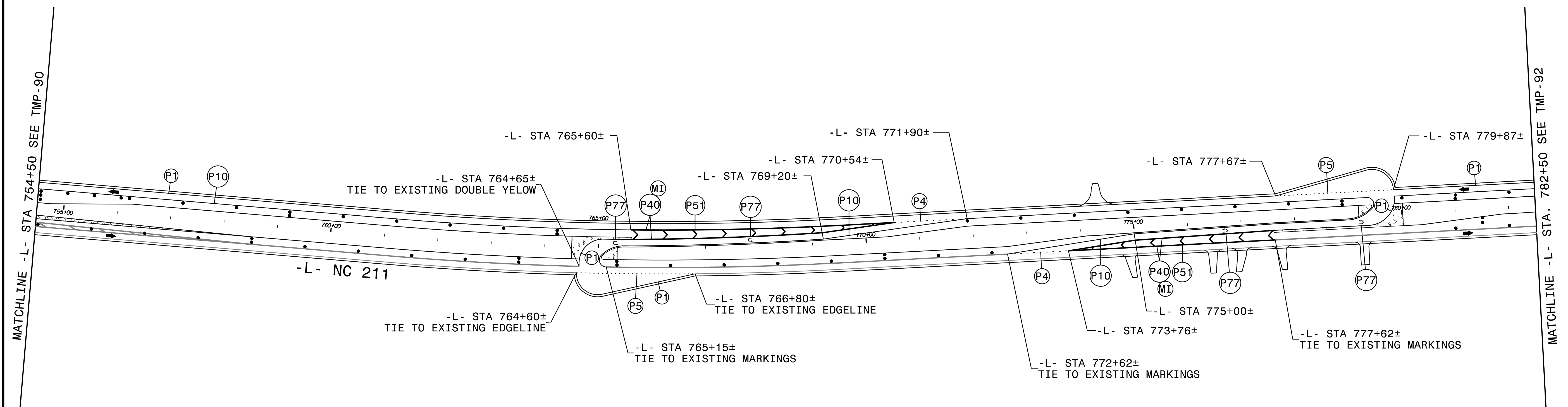
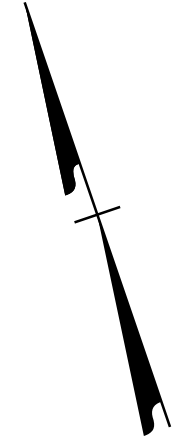

ERECT PROPOSED SIGNING AS APPLICABLE.
 12' LANES

APPROVED: *Kevin W. Bisby*
182P8CA2P384404

DATE: 10/15/2024

SEAL

**DOCUMENT NOT CONSIDERED FINAL
 UNLESS ALL SIGNATURES COMPLETED**

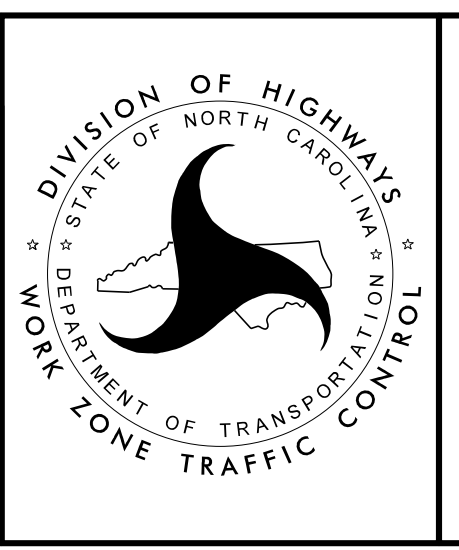

PHASE III
 STEP 1 DETAILS

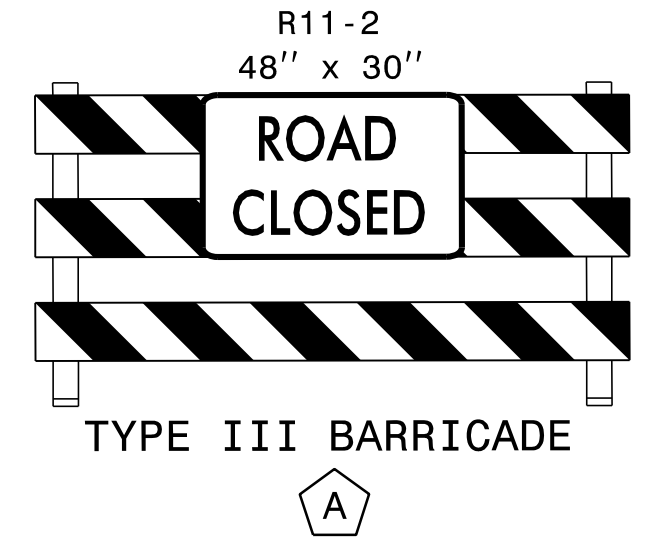
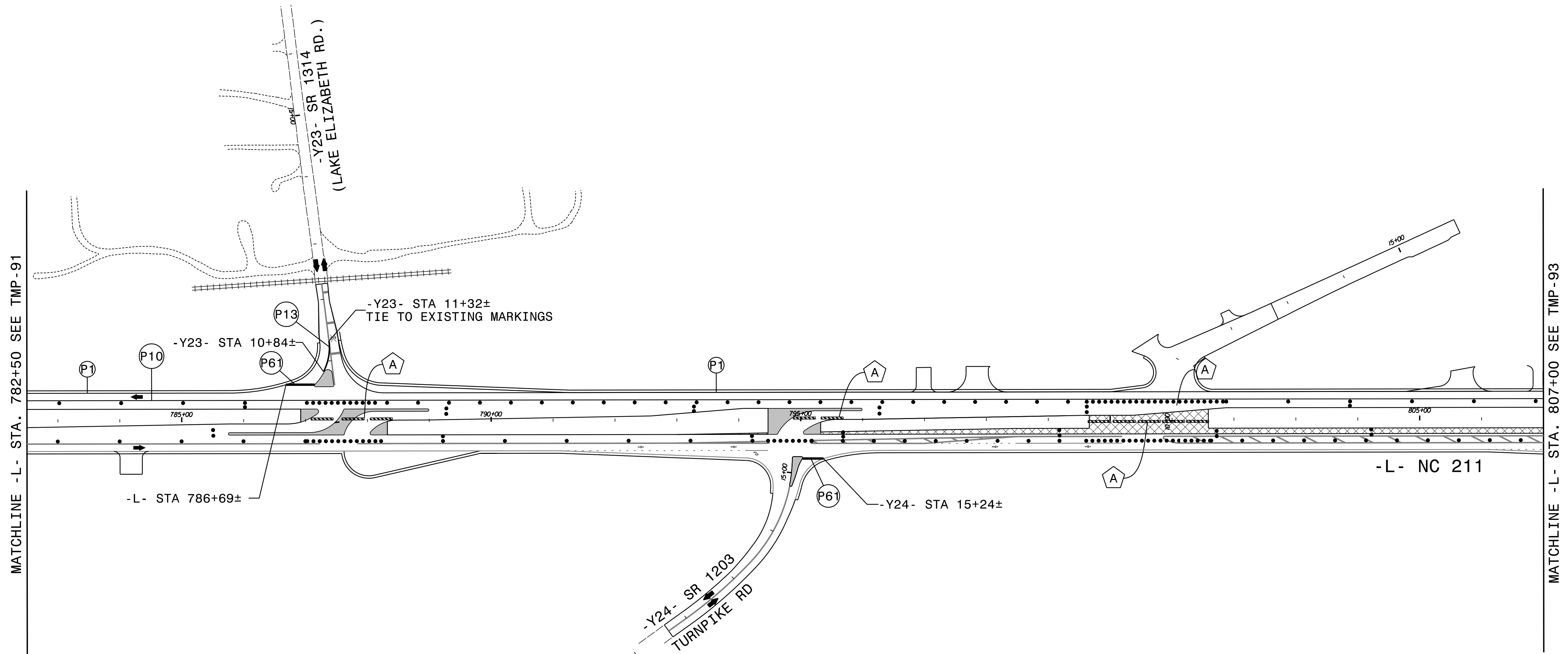
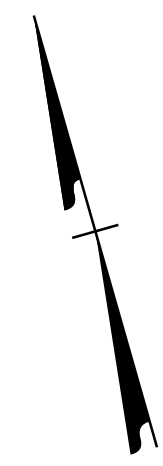

ATTACH SIGN R11-2 TO BOTH SIDES OF BARRICADE

ERECT PROPOSED SIGNING AS APPLICABLE.
 12' LANES.

APPROVED: *Kevin W. Bisby*
382P8CA2P364404
 DATE: 10/15/2024

SEAL

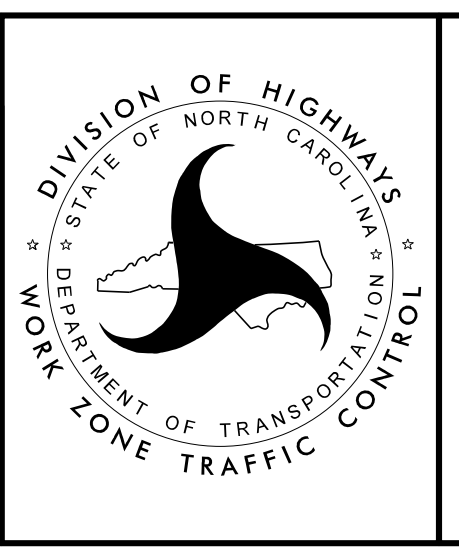

PHASE III
 STEP 1 DETAILS

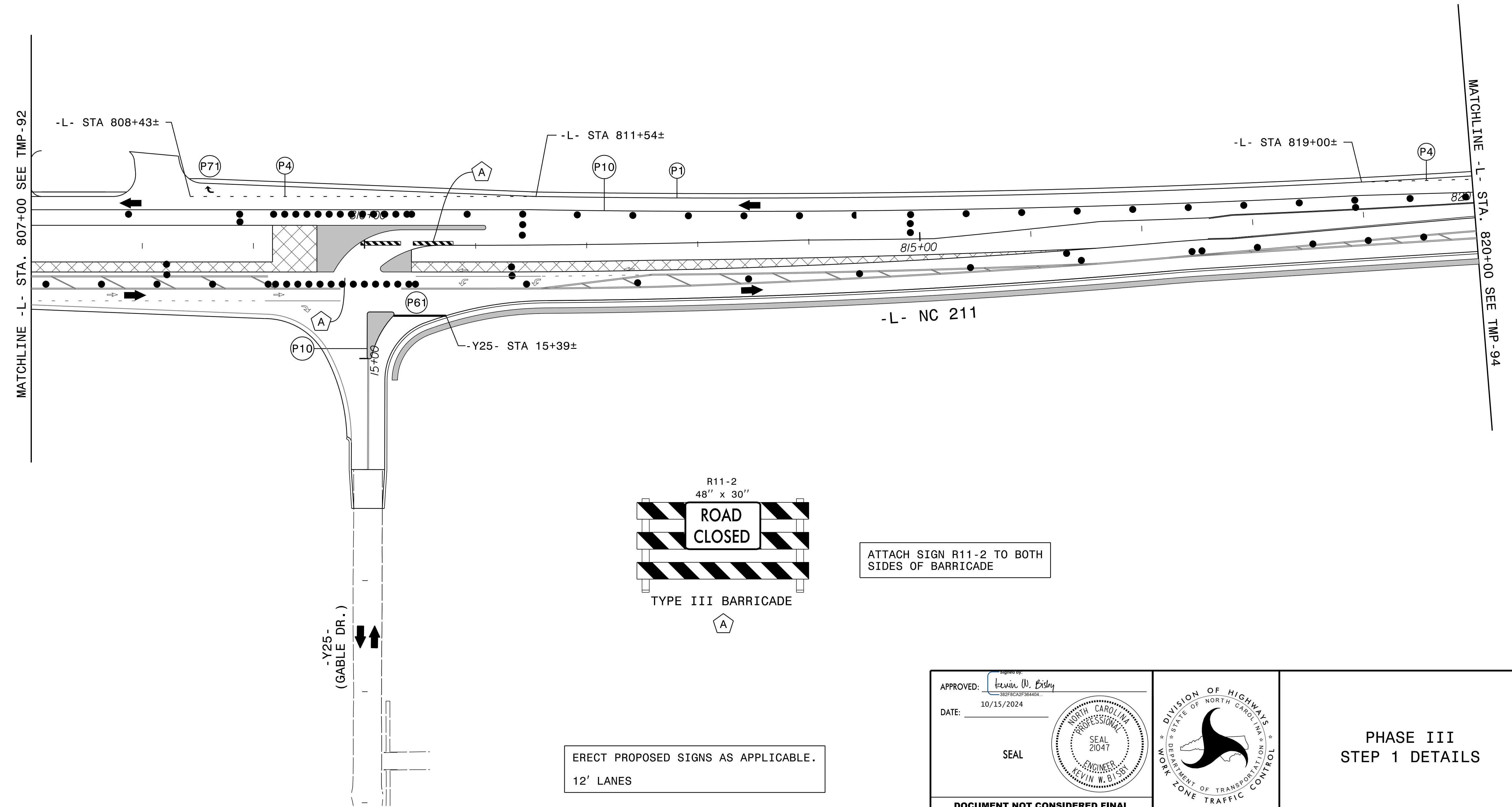
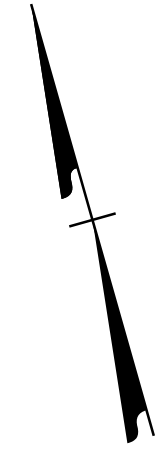

8/28/2024
 RST05_TMP_psh93.dgn
 Rolsby

APPROVED: *Kevin W. Bisby*
18298CA2P364404
 DATE: 10/15/2024
 SEAL

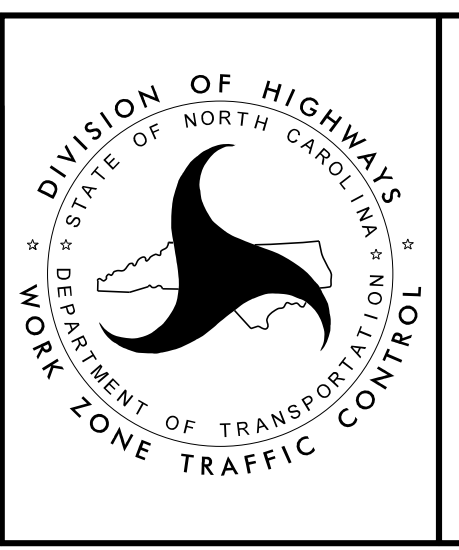

**PHASE III
 STEP 1 DETAILS**

ERECT PROPOSED SIGNS AS APPLICABLE.
 12' LANES

ATTACH SIGN R11-2 TO BOTH
 SIDES OF BARRICADE

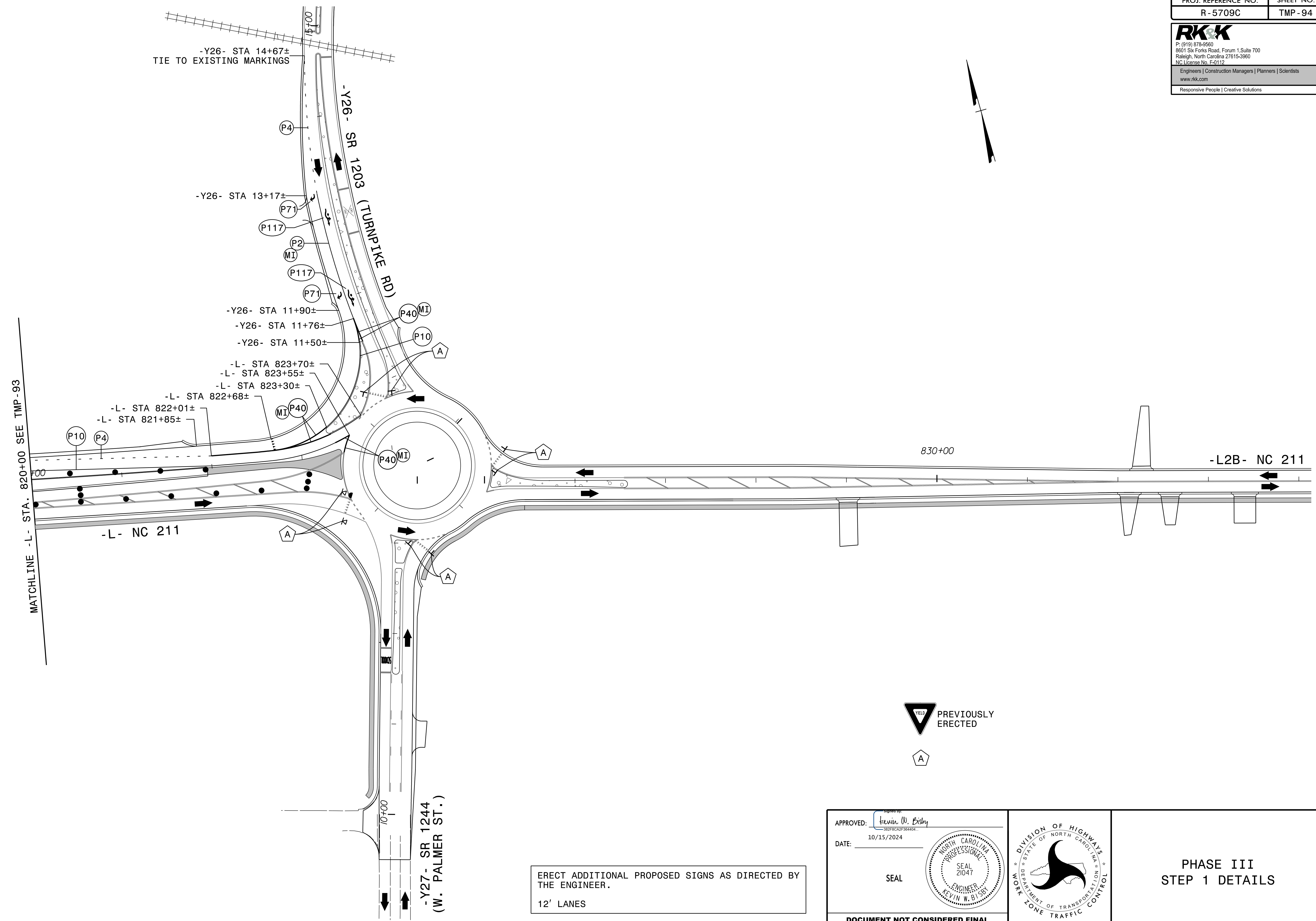

MATCHLINE -L- STA. 820+00 SEE TMP-93

ERECT ADDITIONAL PROPOSED SIGNS AS DIRECTED BY THE ENGINEER.
 12' LANES



APPROVED: *Kevin W. Bisby*
Signed by
38298CA2P384404
 DATE: 10/15/2024

SEAL

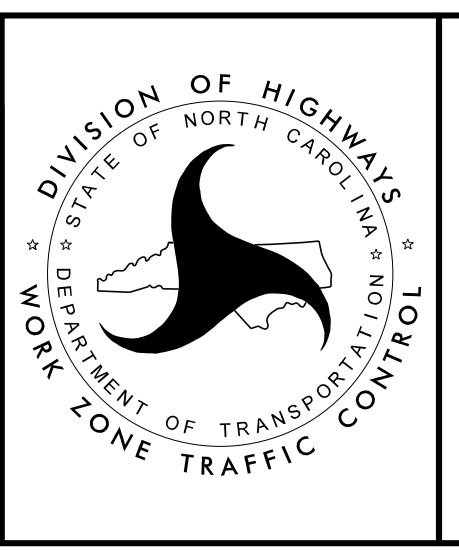

PHASE III
 STEP 1 DETAILS

DOCUMENT NOT CONSIDERED FINAL
 UNLESS ALL SIGNATURES COMPLETED

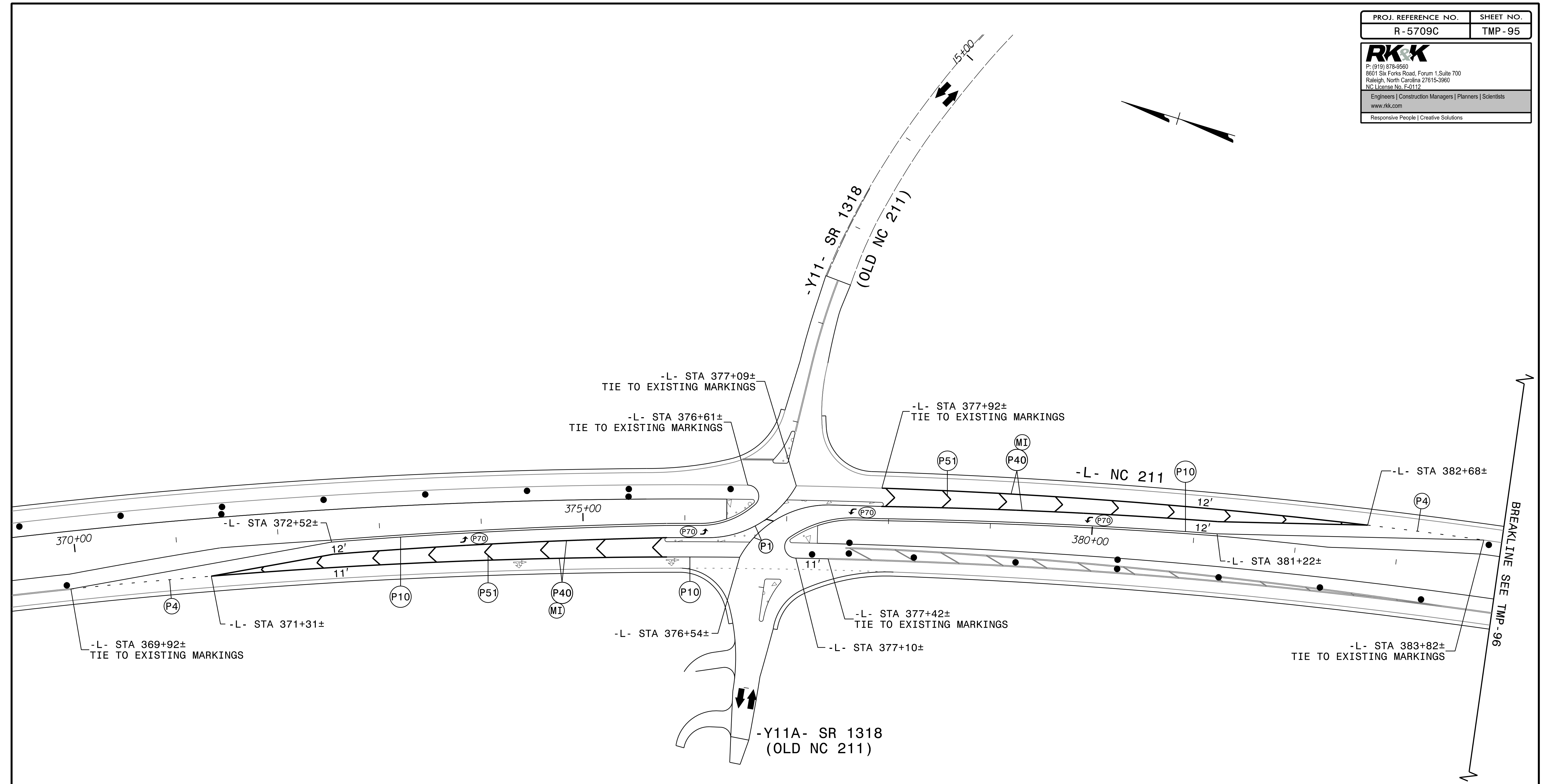
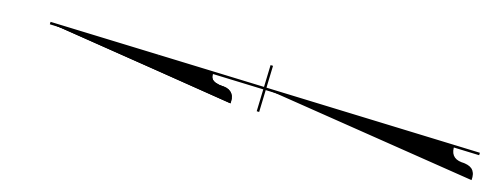

9/30/2024
 R-5709-TMP-psht95.dgn
 Robby

ERECT PROPOSED SIGNING AS APPLICABLE

APPROVED: *Kevin W. Bisby*
38298CA2P384404
 DATE: 10/15/2024

SEAL

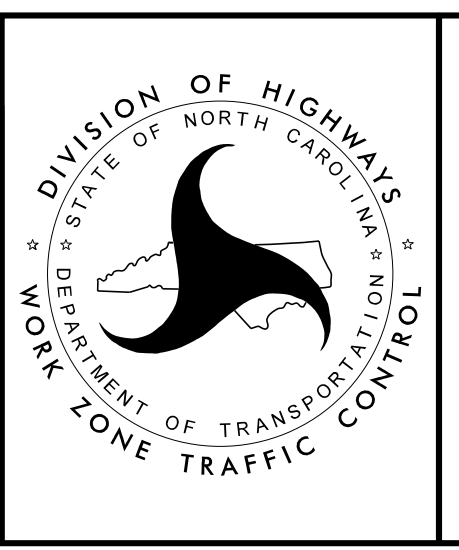

**PHASE III
 STEP 2 DETAILS**

**DOCUMENT NOT CONSIDERED FINAL
 UNLESS ALL SIGNATURES COMPLETED**