

STATE OF NORTH CAROLINA  
DEPARTMENT OF TRANSPORTATION  
RALEIGH, N.C.

PROPOSAL

DATE AND TIME OF BID OPENING: **Dec 17, 2024 AT 02:00 PM**

CONTRACT ID C204988  
WBS 39001.3.2

FEDERAL-AID NO. STATE FUNDED  
COUNTY CUMBERLAND  
T.I.P NO. U-3422A  
MILES 1.622  
ROUTE NO. SR-1003  
LOCATION SR-1003 (CAMDEN RD) FROM PROPOSED FAYETTEVILLE OUTER LOOP  
TO WEST OF SR-1112 (ROCKFISH RD).

TYPE OF WORK GRADING, DRAINAGE, PAVING, SIGNALS, AND WALLS.

**NOTICE:**

ALL BIDDERS SHALL COMPLY WITH ALL APPLICABLE LAWS REGULATING THE PRACTICE OF GENERAL CONTRACTING AS CONTAINED IN CHAPTER 87 OF THE GENERAL STATUTES OF NORTH CAROLINA WHICH REQUIRES THE BIDDER TO BE LICENSED BY THE N.C. LICENSING BOARD FOR CONTRACTORS WHEN BIDDING ON ANY NON-FEDERAL AID PROJECT WHERE THE BID IS \$30,000 OR MORE, EXCEPT FOR CERTAIN SPECIALTY WORK AS DETERMINED BY THE LICENSING BOARD. BIDDERS SHALL ALSO COMPLY WITH ALL OTHER APPLICABLE LAWS REGULATING THE PRACTICES OF ELECTRICAL, PLUMBING, HEATING AND AIR CONDITIONING AND REFRIGERATION CONTRACTING AS CONTAINED IN CHAPTER 87 OF THE GENERAL STATUTES OF NORTH CAROLINA. NOTWITHSTANDING THESE LIMITATIONS ON BIDDING, THE BIDDER WHO IS AWARDED ANY FEDERAL - AID FUNDED PROJECT SHALL COMPLY WITH CHAPTER 87 OF THE GENERAL STATUTES OF NORTH CAROLINA FOR LICENSING REQUIREMENTS WITHIN 60 CALENDAR DAYS OF BID OPENING.

**BIDS WILL BE RECEIVED AS SHOWN BELOW:**

**THIS IS A ROADWAY & STRUCTURE PROPOSAL**

**5% BID BOND OR BID DEPOSIT REQUIRED**

---

**PROPOSAL FOR THE CONSTRUCTION OF  
CONTRACT No. C204988 IN CUMBERLAND COUNTY, NORTH CAROLINA  
DEPARTMENT OF TRANSPORTATION,  
RALEIGH, NORTH CAROLINA**

The Bidder has carefully examined the location of the proposed work to be known as Contract No. **C204988** has carefully examined the plans and specifications, which are acknowledged to be part of the proposal, the special provisions, the proposal, the form of contract, and the forms of contract payment bond and contract performance bond; and thoroughly understands the stipulations, requirements and provisions. The undersigned bidder agrees to bound upon his execution of the bid and subsequent award to him by the Board of Transportation in accordance with this proposal to provide the necessary contract payment bond and contract performance bond within fourteen days after the written notice of award is received by him. The undersigned Bidder further agrees to provide all necessary machinery, tools, labor, and other means of construction; and to do all the work and to furnish all materials, except as otherwise noted, necessary to perform and complete the said contract in accordance with the *2024 Standard Specifications for Roads and Structures* by the dates(s) specified in the Project Special Provisions and in accordance with the requirements of the Engineer, and at the unit or lump sum prices, as the case may be, for the various items given on the sheets contained herein.

The Bidder shall provide and furnish all the materials, machinery, implements, appliances and tools, and perform the work and required labor to construct and complete Contract No. **C204988** in **Cumberland County**, for the unit or lump sum prices, as the case may be, bid by the Bidder in his bid and according to the proposal, plans, and specifications prepared by said Department, which proposal, plans, and specifications show the details covering this project, and hereby become a part of this contract.

The published volume entitled *North Carolina Department of Transportation, Raleigh, Standard Specifications for Roads and Structures, January 2024* with all amendments and supplements thereto, is by reference incorporated into and made a part of this contract; that, except as herein modified, all the construction and work included in this contract is to be done in accordance with the specifications contained in said volume, and amendments and supplements thereto, under the direction of the Engineer.

If the proposal is accepted and the award is made, the contract is valid only when signed either by the Contract Officer or such other person as may be designated by the Secretary to sign for the Department of Transportation. The conditions and provisions herein cannot be changed except over the signature of the said Contract Officer.

The quantities shown in the itemized proposal for the project are considered to be approximate only and are given as the basis for comparison of bids. The Department of Transportation may increase or decrease the quantity of any item or portion of the work as may be deemed necessary or expedient.

An increase or decrease in the quantity of an item will not be regarded as sufficient ground for an increase or decrease in the unit prices, nor in the time allowed for the completion of the work, except as provided for the contract.

Accompanying this bid is a bid bond secured by a corporate surety, or certified check payable to the order of the Department of Transportation, for five percent of the total bid price, which deposit is to be forfeited as liquidated damages in case this bid is accepted and the Bidder shall fail to provide the required payment and performance bonds with the Department of Transportation, under the condition of this proposal, within 14 calendar days after the written notice of award is received by him, as provided in the *Standard Specifications*; otherwise said deposit will be returned to the Bidder.



*State Contract Officer*

Signed by:  
  
 52C46046381F443... 11/13/2024

**TABLE OF CONTENTS**

**COVER SHEET**  
**PROPOSAL SHEET**

**PROJECT SPECIAL PROVISIONS**

HAUL ROADS:..... G-1  
 CONTRACT TIME AND LIQUIDATED DAMAGES: ..... G-1  
 INTERMEDIATE CONTRACT TIME NUMBER 1 AND LIQUIDATED DAMAGES: ..... G-1  
 INTERMEDIATE CONTRACT TIME NUMBER 2 AND LIQUIDATED DAMAGES: ..... G-2  
 INTERMEDIATE CONTRACT TIME NUMBER 3 AND LIQUIDATED DAMAGES: ..... G-3  
 ALTERNATE BIDS:..... G-3  
 PERMANENT VEGETATION ESTABLISHMENT:..... G-4  
 CONSTRUCTION MORATORIUM:..... G-4  
 MAJOR CONTRACT ITEMS: ..... G-5  
 SPECIALTY ITEMS:..... G-5  
 FUEL PRICE ADJUSTMENT:..... G-5  
 STEEL PRICE ADJUSTMENT:..... G-7  
 SCHEDULE OF ESTIMATED COMPLETION PROGRESS:..... G-18  
 MINORITY BUSINESS ENTERPRISE AND WOMEN BUSINESS ENTERPRISE: ..... G-18  
 RESTRICTIONS ON ITS EQUIPMENT AND SERVICES:..... G-35  
 USE OF UNMANNED AIRCRAFT SYSTEM (UAS): ..... G-35  
 EQUIPMENT IDLING GUIDELINES:..... G-35  
 SUBSURFACE INFORMATION:..... G-36  
 MAINTENANCE OF THE PROJECT: ..... G-36  
 COOPERATION BETWEEN CONTRACTORS:..... G-37  
 BID DOCUMENTATION: ..... G-37  
 TWELVE MONTH GUARANTEE:..... G-40  
 OUTSOURCING OUTSIDE THE USA:..... G-41  
 EROSION AND SEDIMENT CONTROL/STORMWATER CERTIFICATION: ..... G-41  
 PROCEDURE FOR MONITORING BORROW PIT DISCHARGE:..... G-46  
 NOTE TO CONTRACTOR: ..... G-48

ROADWAY.....R-1

**STANDARD SPECIAL PROVISIONS**

AVAILABILITY OF FUNDS – TERMINATION OF CONTRACTS .....SSP-1  
 NCDOT GENERAL SEED SPECIFICATION FOR SEED QUALITY .....SSP-2  
 ERRATA.....SSP-5  
 PLANT AND PEST QUARANTINES .....SSP-6  
 MINIMUM WAGES .....SSP-7  
 TITLE VI AND NONDISCRIMINATION: .....SSP-8  
 ON-THE-JOB TRAINING.....SSP-17

**UNIT PROJECT SPECIAL PROVISIONS**

GEOTECHNICAL.....GT-1  
TRAFFIC CONTROL ..... TC-1  
UTILITY CONSTRUCTION.....UC-1  
UTILITY BY OTHERS.....UBO-1  
EROSION CONTROL ..... EC-1  
TRAFFIC SIGNALS .....TS-1

**PERMITS** ..... P-1

**PROPOSAL ITEM SHEET**

ITEM SHEET(S)

**PROJECT SPECIAL PROVISIONS****GENERAL****HAUL ROADS:**

(7-16-24)

105

SP1 G04

Revise the *Standard Specifications* as follows:

**Page 1-45, Article 105-15 RESTRICTION OF LOAD LIMITS, line 31,** add the following after second sentence of the second paragraph:

At least 30 days prior to use, the Contractor shall notify the Engineer of any public road proposed for use as a haul road for the project.

**CONTRACT TIME AND LIQUIDATED DAMAGES:**

(8-15-00) (Rev. 5-16-23)

108

SP1 G08 A

The date of availability for this contract is **March 15, 2025**, except that work in jurisdictional waters and wetlands shall not begin until a meeting between the DOT, Regulatory Agencies, and the Contractor is held as stipulated in the permits contained elsewhere in this proposal. This delay in availability has been considered in determining the contract time for this project.

The completion date for this contract is **December 12, 2028**.

Except where otherwise provided by the contract, observation periods required by the contract will not be a part of the work to be completed by the completion date and/or intermediate contract times stated in the contract. The acceptable completion of the observation periods that extend beyond the final completion date shall be a part of the work covered by the performance and payment bonds.

The liquidated damages for this contract are **Two Hundred Dollars (\$ 200.00)** per calendar day. These liquidated damages will not be cumulative with any liquidated damages which may become chargeable under Intermediate Contract Time Number 1.

**INTERMEDIATE CONTRACT TIME NUMBER 1 AND LIQUIDATED DAMAGES:**

(7-1-95) (Rev. 2-21-12)

108

SP1 G13 A

Except for that work required under the Project Special Provisions entitled *Planting, Reforestation* and/or *Permanent Vegetation Establishment*, included elsewhere in this proposal, the Contractor will be required to complete all work included in this contract and shall place and maintain traffic on same.

The date of availability for this intermediate contract time is **March 15, 2025**.

The completion date for this intermediate contract time is **June 15, 2028**.

The liquidated damages for this intermediate contract time are **Two Thousand Dollars (\$ 2,000.00)** per calendar day.

Upon apparent completion of all the work required to be completed by this intermediate date, a final inspection will be held in accordance with Article 105-17 and upon acceptance, the Department will assume responsibility for the maintenance of all work except *Planting, Reforestation* and/or *Permanent Vegetation Establishment*. The Contractor will be responsible for and shall make corrections of all damages to the completed roadway caused by his planting operations, whether occurring prior to or after placing traffic through the project.

**INTERMEDIATE CONTRACT TIME NUMBER 2 AND LIQUIDATED DAMAGES:**

(2-20-07)

108

SPI G14 A

The Contractor shall complete the required work of installing, maintaining, and removing the traffic control devices for lane closures and restoring traffic to the existing traffic pattern. The Contractor shall not close or narrow a lane of traffic on **Camden Road (-L-)** during the following time restrictions:

**DAY AND TIME RESTRICTIONS**

**Monday thru Friday, 6:00 A.M. to 9:00 A.M. and 4:00 P.M. to 7:00 P.M.**

In addition, the Contractor shall not close or narrow a lane of traffic on **Camden Road (-L-)**, detain and/or alter the traffic flow on or during holidays, holiday weekends, special events, or any other time when traffic is unusually heavy, including the following schedules:

**HOLIDAY AND HOLIDAY WEEKEND LANE CLOSURE RESTRICTIONS**

1. For **unexpected occurrence** that creates unusually high traffic volumes, as directed by the Engineer.
2. For **New Year's Day**, between the hours of **6:00 A.M.** December 31<sup>st</sup> and **7:00 P.M.** January 2<sup>nd</sup>. If New Year's Day is on a Friday, Saturday, Sunday or Monday, then until **7:00 P.M.** the following Tuesday.
3. For **Easter**, between the hours of **6:00 A.M.** Thursday and **7:00 P.M.** Monday.
4. For **Memorial Day**, between the hours of **6:00 A.M.** Friday and **7:00 P.M.** Tuesday.
5. For **Independence Day**, between the hours of **6:00 A.M.** the day before Independence Day and **7:00 P.M.** the day after Independence Day.  
  
If **Independence Day** is on a Friday, Saturday, Sunday or Monday, then between the hours of **6:00 A.M.** the Thursday before Independence Day and **7:00 P.M.** the Tuesday after Independence Day.
6. For **Labor Day**, between the hours of **6:00 A.M.** Friday and **7:00 P.M.** Tuesday.
7. For **Thanksgiving**, between the hours of **6:00 A.M.** Tuesday and **7:00 P.M.** Monday.

8. For **Christmas**, between the hours of **6:00 A.M.** the Friday before the week of Christmas Day and **7:00 P.M.** the following Tuesday after the week of Christmas Day.

Holidays and holiday weekends shall include New Year's, Easter, Memorial Day, Independence Day, Labor Day, Thanksgiving, and Christmas. The Contractor shall schedule his work so that lane closures will not be required during these periods, unless otherwise directed by the Engineer.

The time of availability for this intermediate contract work shall be the time the Contractor begins to install all traffic control devices for lane closures according to the time restrictions listed herein.

The completion time for this intermediate contract work shall be the time the Contractor is required to complete the removal of all traffic control devices for lane closures according to the time restrictions stated above and place traffic in the existing traffic pattern.

The liquidated damages are **Two Hundred Fifty Dollars (\$ 250.00)** per hour.

**INTERMEDIATE CONTRACT TIME NUMBER 3 AND LIQUIDATED DAMAGES:**

(2-20-07) (Rev. 6-18-13)

108

SP1 G14 H

The Contractor shall complete the work required of **Phase 1, Step #5** as shown on Sheet **TMP-3** and shall place and maintain traffic on same.

The date of availability for this intermediate contract time is the date the Contractor elects to begin the work.

The completion date for this intermediate contract time is the date which is **seven (7)** consecutive calendar days after and including the date the Contractor begins this work.

The liquidated damages are **Six Hundred Dollars (\$ 600.00)** per calendar day.

**ALTERNATE BIDS:**

(12-17-24)

103

SP1 G15

Revise the *Standard Specifications* as follows:

**Page 1-22, Subarticle 103-2(A)(7) Paper Bids, lines 39-41**, replace the last sentence of this subarticle with the following:

Where the bidder submits a unit price other than zero for more than one item of an authorized alternate, the Department will determine the lowest total price based on the alternate bid and if there are multiple alternates at the lowest total price the alternate will be determined by the Department.

**Page 1-23, Subarticle 103-2(B)(5) Electronic Bids, lines 7-9**, replace the last sentence of this subarticle with the following:

Where the bidder submits a unit price other than zero for more than one item of an authorized alternate, the Department will determine the lowest total price based on the alternate bid and if there are multiple alternates at the lowest total price the alternate will be determined by the Department.

**PERMANENT VEGETATION ESTABLISHMENT:**

(2-16-12)(Rev. 1-16-24)

104

SP1 G16

Establish a permanent stand of the vegetation mixture shown in the contract. During the period between initial vegetation planting and final project acceptance, perform all work necessary to establish permanent vegetation on all erodible areas within the project limits, as well as, in borrow and waste pits. This work shall include erosion control device maintenance and installation, repair seeding and mulching, supplemental seeding and mulching, mowing, and fertilizer topdressing, as directed. All work shall be performed in accordance with the applicable section of the *Standard Specifications*. All work required for initial vegetation planting shall be performed as a part of the work necessary for the completion and acceptance of the Intermediate Contract Time (ICT). Between the time of ICT and Final Project acceptance, or otherwise referred to as the vegetation establishment period, the Department will be responsible for preparing the required National Pollutant Discharge Elimination System (NPDES) inspection records.

Once the Engineer has determined that the permanent vegetation establishment requirement has been achieved at an 80% vegetation density (the amount of established vegetation per given area to stabilize the soil) and no erodible areas exist within the project limits, the Contractor will be notified to remove the remaining erosion control devices that are no longer needed. The Contractor will be responsible for, and shall correct any areas disturbed by operations performed in permanent vegetation establishment and the removal of temporary erosion control measures, whether occurring prior to or after placing traffic on the project.

Payment for *Response for Erosion Control, Seeding and Mulching, Repair Seeding, Supplemental Seeding, Mowing, Fertilizer Topdressing, Silt Excavation, and Stone for Erosion Control* will be made at contract unit prices for the affected items. Work required that is not represented by contract line items will be paid in accordance with Articles 104-7 or 104-3 of the *Standard Specifications*. No additional compensation will be made for maintenance and removal of temporary erosion control items.

**CONSTRUCTION MORATORIUM:**

(1-19-16)

SP1 G18C

At individual project sites where a total of 1.0 acre or more of tree clearing will occur, no tree clearing will occur during the portion of the day that the air temperature is less than 40 degrees Fahrenheit in order to protect NLEBs that may be in torpor.



**MAJOR CONTRACT ITEMS:**

(2-19-02)(Rev. 1-16-24)

104

SP1 G28

The following listed items are the major contract items for this contract (see Article 104-5 of the *Standard Specifications*):

<b>Line #</b>	<b>Description</b>
38	Asphalt Conc Base Course, Type B25.0C
39	Asphalt Conc Intermediate Course, Type I19.0C
41	Asphalt Conc Surface Course, Type S9.5C
113	12" Water Line

**SPECIALTY ITEMS:**

(7-1-95)(Rev. 1-16-24)

108-6

SP1 G37

Items listed below will be the specialty items for this contract (see Article 108-6 of the *Standard Specifications*).

<b>Line #</b>	<b>Description</b>
71-74	Guardrail
79-82	Signing
98-103	Long-Life Pavement Markings
215 or 216 or 217 or 218 or 219	Permanent Pavement Markers
111-144	Utility Construction
145-178	Erosion Control
179-214	Signals/ITS System

**FUEL PRICE ADJUSTMENT:**

(11-15-05)(Rev. 1-16-24)

109-8

SP1 G43

**Page 1-82, Article 109-8, FUEL PRICE ADJUSTMENTS**, add the following:

The base index price for DIESEL #2 FUEL is \$ **2.2926** per gallon. Where any of the following are included as pay items in the contract, they will be eligible for fuel price adjustment.

The pay items and the fuel factor used in calculating adjustments to be made will be as follows:

<b>Description</b>	<b>Units</b>	<b>Fuel Usage Factor Diesel</b>
Unclassified Excavation	Gal/CY	0.29
Borrow Excavation	Gal/CY	0.29
Class IV Subgrade Stabilization	Gal/Ton	0.55
Aggregate Base Course	Gal/Ton	0.55
Sub-Ballast	Gal/Ton	0.55
Erosion Control Stone	Gal/Ton	0.55
Rip Rap, Class _____	Gal/Ton	0.55
Asphalt Concrete Base Course, Type _____	Gal/Ton	0.90 or 2.90
Asphalt Concrete Intermediate Course, Type _____	Gal/Ton	0.90 or 2.90
Asphalt Concrete Surface Course, Type _____	Gal/Ton	0.90 or 2.90
Open-Graded Asphalt Friction Course	Gal/Ton	0.90 or 2.90
Permeable Asphalt Drainage Course, Type _____	Gal/Ton	0.90 or 2.90
Sand Asphalt Surface Course, Type _____	Gal/Ton	0.90 or 2.90
Ultra-thin Bonded Wearing Course	Gal/Ton	0.90 or 2.90
Aggregate for Cement Treated Base Course	Gal/Ton	0.55
Portland Cement for Cement Treated Base Course	Gal/Ton	0.55
> 11" Portland Cement Concrete Pavement	Gal/SY	0.327
Concrete Shoulders Adjacent to > 11" Pavement	Gal/SY	0.327
9" to 11" Portland Cement Concrete Pavement	Gal/SY	0.272
Concrete Shoulders Adjacent to 9" to 11" Pavement	Gal/SY	0.272
< 9" Portland Cement Concrete Pavement	Gal/SY	0.245
Concrete Shoulders Adjacent to < 9" Pavement	Gal/SY	0.245

For the asphalt items noted in the chart as eligible for fuel adjustments, the bidder may include the *Fuel Usage Factor Adjustment Form* with their bid submission if they elect to use the fuel usage factor. The *Fuel Usage Factor Adjustment Form* is found at the following link:

<https://connect.ncdot.gov/letting/LetCentral/Fuel%20Usage%20Factor%20Adjustment%20Form%20-%20Starting%20Nov%202022%20Lettings.pdf>

Select either 2.90 Gal/Ton fuel factor or 0.90 Gal/Ton fuel factor for each asphalt line item on the *Fuel Usage Factor Adjustment Form*. The selected fuel factor for each asphalt item will remain in effect for the duration of the contract.

Failure to complete the *Fuel Usage Factor Adjustment Form* will result in using 2.90 gallons per ton as the Fuel Usage Factor for Diesel for the asphalt items noted above. The contractor will not be permitted to change the Fuel Usage Factor after the bids are submitted.

**STEEL PRICE ADJUSTMENT:**

(4-19-22)(Rev. 12-20-22)

SP1 G47

**Description and Purpose**

Steel price adjustments will be made to the payments due the Contractor for items as defined herein that are permanently incorporated into the work, when the price of raw steel mill products utilized on the contract have fluctuated. The Department will adjust monthly progress payments up or down as appropriate for cost changes in steel according to this provision.

**Eligible Items**

The list of eligible bid items for steel price adjustment can be found on the Departments website at the following address:

<https://connect.ncdot.gov/letting/LetCentral/Eligible%20Bid%20Items%20for%20Steel%20Price%20Adjustment.xlsx>

Nuts, bolts, anchor bolts, rebar chairs, connecting bands and other miscellaneous hardware associated with these items shall not be included in the price adjustment.

Adjustments will only be made for fluctuations in the material cost of the steel used in the above products as specified in the Product Relationship Table below. The producing mill is defined as the source of steel product before any fabrication has occurred (e.g., coil, plate, rebar, hot rolled shapes, etc.). No adjustment will be made for changes in the cost of fabrication, coating, shipping, storage, etc.

No steel price adjustments will be made for any products manufactured from steel having an adjustment date, as defined by the Product Relationship Table below, prior to the letting date.

**Bid Submittal Requirements**

The successful bidder, within 14 calendar days after the notice of award is received by him, shall provide the completed Form SPA-1 to the Department (State Contract Officer or Division Contract Engineer) along with the payment bonds, performance bonds and contract execution signature sheets in a single submittal. If Form SPA-1 is not included in the same submittal as the payment bonds, performance bonds and contract execution signature sheets, the Contractor will not be eligible for any steel price adjustment for any item in the contract for the life of the contract. Form SPA-1 can be found on the Department's website at the following address:

<https://connect.ncdot.gov/letting/LetCentral/Form%20SPA-1.xlsm>

The Contractor shall provide Form SPA-1 listing the Contract Line Number, (with corresponding Item Number, Item Description, and Category) for the steel products they wish to have an adjustment calculated. Only the contract items corresponding to the list of eligible item numbers for steel price adjustment may be entered on Form SPA-1. The Contractor may choose to have steel price adjustment applied to any, all, or none of the eligible items. However, the Contractor's selection of items for steel price adjustment or non-selection (non-participation)

may not be changed once Form SPA-1 has been received by the Department. Items the Bidder chooses for steel price adjustment must be designated by writing the word “Yes” in the column titled “Option” by each Pay Item chosen for adjustment. Should the bidder elect an eligible steel price item, the entire quantity of the line item will be subject to the price adjustment for the duration of the Contract. The Bidder’s designations on Form SPA-1 must be written in ink or typed and signed by the Bidder (Prime Contractor) to be considered complete. Items not properly designated, designated with “No”, or left blank on the Bidder’s Form SPA-1 will automatically be removed from consideration for adjustment. No steel items will be eligible for steel price adjustment on this Project if the Bidder fails to return Form SPA-1 in accordance with this provision.

### Establishing the Base Price

The Department will use a blend of monthly average prices as reported from the Fastmarkets platform to calculate the monthly adjustment indices (BI and MI). This data is typically available on the first day of the month for the preceding month. The indices will be calculated by the Department for the different categories found on the Product Relationship Table below. For item numbers that include multiple types of steel products, the category listed for that item number will be used for adjusting each steel component.

The bidding index for Category 1 Steel items is **\$ 35.70** per hundredweight.  
 The bidding index for Category 2 Steel items is **\$ 44.54** per hundredweight.  
 The bidding index for Category 3 Steel items is **\$ 60.50** per hundredweight.  
 The bidding index for Category 4 Steel items is **\$ 37.00** per hundredweight.  
 The bidding index for Category 5 Steel items is **\$ 47.69** per hundredweight.  
 The bidding index for Category 6 Steel items is **\$ 46.79** per hundredweight.  
 The bidding index for Category 7 Steel items is **\$ 38.34** per hundredweight.

The bidding index represents a selling price of steel based on Fastmarkets data for the month of **October 2024**.

- MI = Monthly Index. – in Dollars (\$) per hundredweight (CWT). Use the adjustment indices from the month the steel was shipped from the producing mill, received on the project, or member cast as defined in the Product Relationship Table.
- BI = Bidding Index. - in Dollars (\$) per hundredweight (CWT). Use the adjustment indices as listed in the proposal.

<i>Product Relationship Table</i>			
<i>Steel Product (Title)</i>	BI, MI*	Adjustment Date for MI	Category
Reinforcing Steel, Bridge Deck, and SIP Forms	Based on one or more Fastmarkets indices	Delivery Date from Producing Mill	1
Structural Steel and Encasement Pipe	Based on one or more Fastmarkets indices	Delivery Date from Producing Mill	2
Steel H-Piles, Soldier Pile Walls	Based on one or more Fastmarkets indices	Delivery Date from Producing Mill	3
Guardrail Items and Pipe	Based on one or more	Material Received Date**	4

Piles	Fastmarkets indices		
Fence Items	Based on one or more Fastmarkets indices	Material Received Date**	5
Overhead Sign Assembly, Signal Poles, High Mount Standards	Based on one or more Fastmarkets indices	Material Received Date**	6
Prestressed Concrete Members	Based on one or more Fastmarkets indices	Cast Date of Member	7
* BI and MI are in converted units of Dollars per Hundredweight (\$/CWT)			
** Material Received Date is defined as the date the materials are received on the project site. If a material prepayment is made for a Category 4-6 item, the Adjustment Date to be used will be the date of the prepayment request instead of the Materials Received Date.			

Submit documentation to the Engineer for all items listed in the Contract for which the Contractor is requesting a steel price adjustment.

### Submittal Requirements

The items in categories 1,2, and 3, shall be specifically stored, labeled, or tagged, recognizable by color marking, and identifiable by Project for inspection and audit verification immediately upon arrival at the fabricator.

Furnish the following documentation for all steel products to be incorporated into the work and documented on Form SPA-2, found on the Departments website at the following address:

<https://connect.ncdot.gov/projects/construction/Construction%20Forms/Form%20SPA-2.xlsx>

Submit all documentation to the Engineer prior to incorporation of the steel into the completed work. The Department will withhold progress payments for the affected contract line item if the documentation is not provided and at the discretion of the Engineer the work is allowed to proceed. Progress payments will be made upon receipt of the delinquent documentation.

#### Step 1 (Form SPA -2)

Utilizing Form SPA-2, submit separate documentation packages for each line item from Form SPA-1 for which the Contractor opted for a steel price adjustment. For line items with multiple components of steel, each component should be listed separately. Label each SPA-2 documentation package with a unique number as described below.

- a. Documentation package number: (Insert the contract line-item) - (Insert sequential package number beginning with "1").

Example: 412 - 1,  
412 - 2,  
424 - 1,  
424 - 2,  
424 - 3, etc.

- b. The steel product quantity in pounds

- i. The following sources should be used, in declining order of precedence, to determine the weight of steel/iron, based on the Engineers decision:
  1. Department established weights of steel/iron by contract pay item per pay unit;
  2. Approved Shop Drawings;
  3. Verified Shipping Documents;
  4. Contract Plans;
  5. Standard Drawing Sheets;
  6. Industry Standards (i.e., AISC Manual of Steel Construction, AWWA Standards, etc.); and
  7. Manufacture's data.
- ii. Any item requiring approved shop drawings shall have the weights of steel calculated and shown on the shop drawings or submitted and certified separately by the fabricator.
- c. The date the steel product, subject to adjustment, was shipped from the producing mill (Categories 1-3), received on the project (Categories 4-6), or casting date (Category 7).

#### Step 2 (Monthly Calculator Spreadsheet)

For each month, upon the incorporation of the steel product into the work, provide the Engineer the following:

- 1) Completed NCDOT Steel Price Adjustment Calculator Spreadsheet, summarizing all the steel submittal packages (Form SPA-2) actually incorporated into the completed work in the given month.
  - a. Contract Number
  - b. Bidding Index Reference Month
  - c. Contract Completion Date or Revised Completion Date
  - d. County, Route, and Project TIP information
  - e. Item Number
  - f. Line-Item Description
  - g. Submittal Number from Form SPA-2
  - h. Adjustment date
  - i. Pounds of Steel
- 2) An affidavit signed by the Contractor stating the documentation provided in the NCDOT Steel Price Adjustment Calculator Spreadsheet is true and accurate.

#### **Price Adjustment Conditions**

Download the Monthly Steel Adjustment Spreadsheet with the most current reference data from the Department's website each month at the following address:

<https://connect.ncdot.gov/projects/construction/Construction%20Forms/Form%20SPA-3%20NCDOT%20Steel%20Price%20Adjustment%20Calculator.xlsx>

If the monthly Fastmarkets data is not available, the data for the most recent immediately preceding month will be used as the basis for adjustment.

### Price Adjustment Calculations

The price adjustment will be determined by comparing the percentage of change in index value listed in the proposal (BI) to the monthly index value (MI). (See included sample examples). Weights and date of shipment must be documented as required herein. The final price adjustment dollar value will be determined by multiplying this percentage increase or decrease in the index by the represented quantity of steel incorporated into the work, and the established bidding index (BI) subject to the limitations herein.

#### Price increase/decrease will be computed as follows:

$$\text{SPA} = ((\text{MI} / \text{BI}) - 1) * \text{BI} * (\text{Q} / 100)$$

Where;

SPA = Steel price adjustment in dollars

MI = Monthly Shipping Index. – in Dollars (\$) per hundredweight (CWT). Use the adjustment indices from the month the steel was shipped from the producing mill, received on the project, or member cast as defined in the Product Relationship Table.

BI = Bidding Index. - in Dollars (\$) per hundredweight (CWT). Use the adjustment indices as listed in the proposal.

Q = Quantity of steel, product, pounds actually incorporated into the work as documented by the Contractor, or Design Build Team and verified by the Engineer.

Calculations for price adjustment shall be shown separate from the monthly progress estimate and will not be included in the total cost of work for determination of progress or for extension of Contract time in accordance with Subarticle 108-10(B)(1).

Any apparent attempt to unbalance bids in favor of items subject to price adjustment may result in rejection of the bid proposal.

Adjustments will be paid or charged to the Contractor only. Any Contractor receiving an adjustment under this provision shall distribute the proper proportional part of such adjustments to the subcontractor who performed the applicable work.

Delays to the work caused by steel shortages may be justification for a Contract time extension but will not constitute grounds for claims for standby equipment, extended office overhead, or other costs associated with such delays.

If an increase in the steel material price is anticipated to exceed 50% of the original quoted price, the contractor must notify the Department within 7 days prior to purchasing the material. Upon receipt of such notification, the Department will direct the Contractor to either (1) proceed with the work or (2) suspend the work and explore the use of alternate options.

If the decrease in the steel material exceeds 50% of the original quoted price, the contractor may submit to the Department additional market index information specific to the item in question to dispute the decrease. The Department will review this information and determine if the decrease is warranted.

When the steel product adjustment date, as defined in the Product Relationship Table, is after the approved contract completion date, the steel price adjustments will be based on the lesser value of either the MI for the month of the approved contract completion date or the MI for the actual adjustment date.

If the price adjustment is based on estimated material quantities for that time, and a revision to the total material quantity is made in a subsequent or final estimate, an appropriate adjustment will be made to the price adjustment previously calculated. The adjustment will be based on the same indices used to calculate the price adjustment which is being revised. If the adjustment date of the revised material quantity cannot be determined, the adjustment for the quantity in question, will be based on the indices utilized to calculate the steel price adjustment for the last initial documentation package submission, for the steel product subject to adjustment, that was incorporated into the particular item of work, for which quantities are being finalized.

Example: Structural steel for a particular bridge was provided for in three different shipments with each having a different mill shipping date. The quantity of structural steel actually used for the bridge was calculated and a steel price adjustment was made in a progress payment. At the conclusion of the work an error was found in the plans of the final quantity of structural steel used for the bridge. The quantity to be adjusted cannot be directly related to any one of the three mill shipping dates. The steel price adjustment for the quantity in question would be calculated using the indices that were utilized to calculate the steel price adjustment for the quantity of structural steel represented by the last initial structural steel documentation package submission. The package used will be the one with the greatest sequential number.

**Extra Work/Force Account:**

When steel products, as specified herein, are added to the contract as extra work, in accordance with the provisions of Article 104-7 or 104-3, the Engineer will determine and specify in the supplemental agreement, the need for application of steel price adjustments on a case-by-case basis. No steel price adjustments will be made for any products manufactured from steel having an adjustment date prior to the supplemental agreement execution date. Price adjustments will be made as provided herein, except the Bidding Index will be based on the month in which the supplemental agreement pricing was executed.

For work performed on force account basis, reimbursement of actual material costs, along with the specified overhead and profit markup, will be considered to include full compensation for the current cost of steel and no steel price adjustments will be made.



**Examples Form SPA-2**

**Steel Price Adjustment Submission Form**

Contract Number     C203394     Bid Reference Month     January 2019    

Submittal Date     8/31/2019    

Contract Line Item     237    

Line Item Description     APPROX...LBS Structural Steel    

Sequential Submittal Number     2    

Supplier	Description of material	Location information	Quantity in lbs.	Adjustment Date
XYZ mill	Structural Steel	Structure 3, Spans A-C	1,200,000	May 4, 2020
ABC distributing	Various channel & angle shapes	Structure 3 Spans A-C	35,000	July 14, 2020
		Total Pounds of Steel	1,235,000	

- Note: Attach the following supporting documentation to this form.
- Bill of Lading to support the shipping dates
  - Supporting information for weight documentation (e.g., Pay item reference, Shop drawings, shipping documents, Standards Sheets, industry standards, or manufacturer's data)

By providing this data under my signature, I attest to the accuracy of and validity of the data on this form and certify that no deliberate misrepresentation in any manner has occurred.

Printed Name  
\_\_\_\_\_

Signature  
\_\_\_\_\_

**Examples Form SPA-2**  
**Steel Price Adjustment Submission Form**

Contract Number C203394 Bid Reference Month January 2019

Submittal Date August 31, 2019

Contract Line Item 237

Line Item Description SUPPORT, OVRHD SIGN STR -DFEB – STA 36+00

Sequential Submittal Number 2

Supplier	Description of material	Location information	Quantity in lbs.	Adjustment Date
XYZ mill	Tubular Steel (Vertical legs)	<u>-DFEB – STA 36+00</u>	12000	December 11, 2021
PDQ Mill	4” Tubular steel (Horizontal legs)	<u>-DFEB – STA 36+00</u>	5900	December 11, 2021
ABC distributing	Various channel & angle shapes (see quote)	<u>-DFEB – STA 36+00</u>	1300	December 11, 2021
	Catwalk assembly	<u>-DFEB – STA 36+00</u>	2000	December 11, 2021
Nucor	Flat plate	<u>-DFEB – STA 36+00</u>	650	December 11, 2021
		Total Pounds of Steel	21,850	

Note: Attach the following supporting documentation to this form.

- Bill of Lading to support the shipping dates
- Supporting information for weight documentation (e.g., Pay item reference, Shop drawings, shipping documents, Standards Sheets, industry standards, or manufacturer's data)

By providing this data under my signature, I attest to the accuracy of and validity of the data on this form and certify that no deliberate misrepresentation in any manner has occurred.

Printed Name  
 \_\_\_\_\_

Signature  
 \_\_\_\_\_

**Price Adjustment Sample Calculation (increase)**

---

Project bid on September 17, 2019

Line Item 635 "Structural Steel" has a plan quantity of 2,717,000 lbs.

Bidding Index for Structural Steel (Category 2) in the proposal was \$36.12/CWT = BI

450,000 lbs. of Structural Steel for Structure 2 at Station 44+08.60 were shipped to fabricator from the producing mill in same month, May 2021.

Monthly Index for Structural Steel (Category 2) for May 2021 was \$64.89/CWT = MI

The Steel Price Adjustment formula is as follows:

$$\text{SPA} = ((\text{MI} / \text{BI}) - 1) * \text{BI} * (\text{Q} / 100)$$

Where; SPA = Steel price adjustment in dollars

BI = Bidding Index – in dollars (\$) per hundredweight (CWT). Use the adjustment indices as listed in the proposal.

MI = Mill Shipping Index – in dollars (\$) per hundredweight (CWT). Use the adjustment indices from the month the steel was shipped from the producing mill, received on the project, or member cast as defined in the Product Relationship Table.

Q = Quantity of steel product, in pounds (lbs.) actually incorporated into the work as documented by the Contractor, or Design Build Team and verified by the Engineer.

$$\text{BI} = \$36.12 / \text{CWT}$$

$$\text{MI} = \$64.89 / \text{CWT}$$

$$\% \text{ change} = ((\text{MI} / \text{BI}) - 1) = (\$64.89 / \$36.12 - 1) = (1.79651 - 1) = 0.79651162791$$

$$\text{Q} = 450,000 \text{ lbs.}$$

$$\text{SPA} = 0.79651162791 \times \$36.12 \times (450,000 / 100)$$

$$\text{SPA} = 0.79651162791 * \$36.12 * 4,500$$

$$\text{SPA} = \$129,465 \text{ pay adjustment to Contractor for Structural Steel (Structure 2 at Station 44+08.60)}$$

**Price Adjustment Sample Calculation (decrease)**

---

Project bid on December 18, 2018

Line Item 635 Structural Steel has a plan quantity of 2,717,000 lbs.

Bidding Index for Structural Steel (Category 2) in the proposal was \$46.72/CWT = BI

600,000 lbs. of Structural Steel for Structure 1 at Station 22+57.68 were shipped to fabricator from the producing mill in same month, August 2020.

Monthly Index for Structural Steel (Category 2) for August 2020 was \$27.03/CWT = MI

The Steel Price Adjustment formula is as follows:

$$\text{SPA} = ((\text{MI} / \text{BI}) - 1) * \text{BI} * (\text{Q} / 100)$$

Where; SPA = Steel price adjustment in dollars

BI = Bidding Index – in dollars (\$) per hundredweight (CWT). Use the adjustment indices as listed in the proposal.

MI = Mill Shipping Index – in dollars (\$) per hundredweight (CWT). Use the adjustment indices from the month the steel was shipped from the producing mill, received on the project, or member cast as defined in the Product Relationship Table.

Q = Quantity of steel product, in pounds (lbs.) actually incorporated into the work as documented by the Contractor, or Design Build Team and verified by the Engineer.

$$\text{BI} = \$46.72 / \text{CWT}$$

$$\text{MI} = \$27.03 / \text{CWT}$$

$$\% \text{ change} = ((\text{MI} / \text{BI}) - 1) = (\$27.03 / \$46.72 - 1) = (0.57855 - 1) = -0.421446917808$$

$$\text{Q} = 600,000 \text{ lbs.}$$

$$\text{SPA} = -0.421446917808 * \$46.72 * (600,000 / 100)$$

$$\text{SPA} = -0.421446917808 * \$46.72 * 6,000$$

$$\text{SPA} = \$ 118,140.00 \text{ Credit to the Department for Structural Steel (Structure 1 at Station 22+57.68)}$$

**Price Adjustment Sample Calculation (increase)**

---

Project bid on July 16, 2020

Line Item 614 Reinforced Concrete Deck Slab has a plan quantity of 241974 lbs.

Bidding Index Reference Month was May 2020. Bidding Index for Reinforced Concrete Deck Slab (Category 1) in the proposal was \$29.21/CWT = BI

51,621 lbs. of reinforcing steel and 52,311 lbs. of epoxy coated reinforcing steel for Structure 2 at Station 107+45.55 -L- was shipped to fabricator from the producing mill in same month, May 2021.

Monthly Index for Reinforced Concrete Deck Slab (Category 1) for May 2021 was \$43.13/CWT = MI

The Steel Price Adjustment formula is as follows:

$$\text{SPA} = ((\text{MI} / \text{BI}) - 1) * \text{BI} * (\text{Q} / 100)$$

Where; SPA = Steel price adjustment in dollars

BI = Bidding Index – in dollars (\$) per hundredweight (CWT). Use the adjustment indices as listed in the proposal.

MI = Mill Shipping Index – in dollars (\$) per hundredweight (CWT). Use the adjustment indices from the month the steel was shipped from the producing mill, received on the project, or member cast as defined in the Product Relationship Table.

Q = Quantity of steel product, in pounds (lbs.) actually incorporated into the work as documented by the Contractor, or Design Build Team and verified by the Engineer.

$$\text{BI} = \$29.21 / \text{CWT}$$

$$\text{MI} = \$43.13 / \text{CWT}$$

$$\% \text{ change} = ((\text{MI} / \text{BI}) - 1) = (\$43.13 / \$29.21 - 1) = (1.47655 - 1) = 0.47654912701$$

$$\text{Q} = 103932 \text{ lbs.}$$

$$\text{SPA} = 0.47654912701 * \$29.21 * (103,932 / 100)$$

$$\text{SPA} = 0.47654912701 * \$29.21 * 1,039.32$$

SPA = \$14,467.33 Pay Adjustment to Contractor for Reinforced Concrete Deck Slab (Category 1) at Station 107+45.55 -L-

**SCHEDULE OF ESTIMATED COMPLETION PROGRESS:**

(7-15-08)(Rev. 7-16-24)

108-2

SP1 G58

The Contractor's attention is directed to the Standard Special Provision entitled *Availability of Funds Termination of Contracts* included elsewhere in this proposal. The Department of Transportation's schedule of estimated completion progress for this project as required by that Standard Special Provision is as follows:

	<b><u>Fiscal Year</u></b>	<b><u>Progress (% of Dollar Value)</u></b>
2025	(7/01/24 - 6/30/25)	<b>14%</b> of Total Amount Bid
2026	(7/01/25 - 6/30/26)	<b>34%</b> of Total Amount Bid
2027	(7/01/26 - 6/30/27)	<b>33%</b> of Total Amount Bid
2028	(7/01/27 - 6/30/28)	<b>19%</b> of Total Amount Bid

The Contractor shall also furnish his own progress schedule in accordance with Article 108-2 of the *Standard Specifications*. Any acceleration of the progress as shown by the Contractor's progress schedule over the progress as shown above shall be subject to the approval of the Engineer.

**MINORITY BUSINESS ENTERPRISE AND WOMEN BUSINESS ENTERPRISE:**

(10-16-07)(Rev. 5-9-24)

102-15(J)

SP1 G66

**Description**

The purpose of this Special Provision is to carry out the North Carolina Department of Transportation's policy of ensuring nondiscrimination in the award and administration of contracts financed in whole or in part with State funds.

**Definitions**

*Additional MBE/WBE Subcontractors* - Any MBE/WBE submitted at the time of bid that will not be used to meet the Combined MBE /WBE Goal. No submittal of a Letter of Intent is required.

*Combined MBE/WBE Goal:* A portion of the total contract, expressed as a percentage that is to be performed by committed MBE/WBE subcontractors.

*Committed MBE/WBE Subcontractor* - Any MBE/WBE submitted at the time of bid that is being used to meet the Combined MBE /WBE goal by submission of a Letter of Intent. Or any MBE or WBE used as a replacement for a previously committed MBE or WBE firm.

*Contract Goal Requirement* - The approved participation at time of award, but not greater than the advertised Combined MBE/WBE contract goal.

*Goal Confirmation Letter* - Written documentation from the Department to the bidder confirming the Contractor's approved, committed participation along with a listing of the committed MBE and WBE firms.

*Manufacturer* - A firm that owns (or leases) and operates or maintains a factory or establishment that produces on the premises, the materials or supplies obtained by the Contractor. A firm that makes minor modifications to the materials, supplies, articles, or equipment is not a manufacturer.

*MBE Participation (Anticipated)* - A portion of the total contract, expressed as a percentage that is anticipated to be performed by committed MBE subcontractor(s).

*Minority Business Enterprise (MBE)* - A firm certified as a Disadvantaged Minority-Owned Business Enterprise through the North Carolina Unified Certification Program.

*Regular Dealer* - A firm that owns (or leases), and operates a store, warehouse, or other establishment in which the materials or supplies required for the performance of the contract are bought, kept in sufficient quantities, and regularly sold to the public in the usual course of business. A regular dealer engages in, as its principal business and in its own name, the purchase and sale or lease of the products in question. A regular dealer in such bulk items as steel, concrete or concrete products, gravel, stone, asphalt and petroleum products need not keep such products in stock, if it owns and operates distribution equipment for the products. Any supplement of regular dealers' own distribution equipment shall be by a long-term operating lease and not on an ad hoc or contract-by-contract basis.

*Distributor* - A firm that engages in the regular sale or lease of the items specified by the contract. A distributor assumes responsibility for the items it purchases once they leave the point of origin (e.g., a manufacturer's facility), making it liable for any loss or damage not covered by the carrier's insurance.

*Replacement / Substitution* - A full or partial reduction in the amount of work subcontracted to a committed (or an approved substitute) MBE/WBE firm.

*North Carolina Unified Certification Program (NCUCP)* - A program that provides comprehensive services and information to applicants for MBE/WBE certification. The MBE/WBE program follows the same regulations as the federal Disadvantaged Business Enterprise (DBE) program in accordance with 49 CFR Part 26.

*United States Department of Transportation (USDOT)* - Federal agency responsible for issuing regulations (49 CFR Part 26) and official guidance for the DBE program.

*WBE Participation (Anticipated)* - A portion of the total contract, expressed as a percentage, that is anticipated to be performed by committed WBE subcontractor(s).

*Women Business Enterprise (WBE)* - A firm certified as a Disadvantaged Women-Owned Business Enterprise through the North Carolina Unified Certification Program.

**Forms and Websites Referenced in this Provision**

*Payment Tracking System* - On-line system in which the Contractor enters the payments made to MBE and WBE subcontractors who have performed work on the project.  
<https://apps.dot.state.nc.us/Vendor/PaymentTracking/>

*DBE-IS Subcontractor Payment Information* - Form for reporting the payments made to all MBE/WBE firms working on the project. This form is for paper bid projects only.  
<https://connect.ncdot.gov/business/Turnpike/Documents/Form%20DBE-IS%20Subcontractor%20Payment%20Information.pdf>

*RF-1 MBE/WBE Replacement Request Form* - Form for replacing a committed MBE or WBE.  
<https://connect.ncdot.gov/projects/construction/Construction%20Forms/DBE%20MBE%20WBE%20Replacement%20Form%20and%20Instructions.pdf>

*SAF Subcontract Approval Form* - Form required for approval to sublet the contract.  
<https://connect.ncdot.gov/projects/construction/Construction%20Forms/SAF%20Form%20-%20Subcontract%20Approval%20Form%20Revised%2004-19.xlsm>

*JC-1 Joint Check Notification Form* - Form and procedures for joint check notification. The form acts as a written joint check agreement among the parties providing full and prompt disclosure of the expected use of joint checks.  
<http://connect.ncdot.gov/projects/construction/Construction%20Forms/Joint%20Check%20Notification%20Form.pdf>

*Letter of Intent* - Form signed by the Contractor and the MBE/WBE subcontractor, manufacturer or regular dealer that affirms that a portion of said contract is going to be performed by the signed MBE/WBE for the estimated amount (based on quantities and unit prices) listed at the time of bid.  
<http://connect.ncdot.gov/letting/LetCentral/Letter%20of%20Intent%20to%20Perform%20as%20a%20Subcontractor.pdf>

*Listing of MBE and WBE Subcontractors Form* - Form for entering MBE/WBE subcontractors on a project that will meet the Combined MBE/WBE goal. This form is for paper bids only.  
[http://connect.ncdot.gov/municipalities/Bid%20Proposals%20for%20LGA%20Content/09%20MBE-WBE%20Subcontractors%20\(State\).docx](http://connect.ncdot.gov/municipalities/Bid%20Proposals%20for%20LGA%20Content/09%20MBE-WBE%20Subcontractors%20(State).docx)

*Subcontractor Quote Comparison Sheet* - Spreadsheet for showing all subcontractor quotes in the work areas where MBEs and WBEs quoted on the project. This sheet is submitted with good faith effort packages.  
<http://connect.ncdot.gov/business/SmallBusiness/Documents/DBE%20Subcontractor%20Quote%20Comparison%20Example.xls>



*DBE Regular Dealer/Distributor Affirmation Form* – Form is used to make a preliminary counting determination for each DBE listed as a regular dealer or distributor to assess its eligibility for 60 or 40 percent credit, respectively of the cost of materials or supplies based on its demonstrated capacity and intent to perform as a regular dealer or distributor, as defined in section 49 CFR 26.55 under the contract at issue. A Contractor will submit the completed form with the Letter of Intent.

<https://connect.ncdot.gov/projects/construction/Construction%20Forms/DBE%20Regular%20Dealer-Distributor%20Affirmation%20Form%20-%20USDOT%202024.pdf>

### **Combined MBE/WBE Goal**

The Combined MBE/WBE Goal for this project is **6.0 %**

The Combined Goal was established utilizing the following anticipated participation for Minority Business Enterprises and Women Business Enterprises:

(A) **Minority Business Enterprises 3.0 %**

- (1) *If the anticipated MBE participation is more than zero*, the Contractor shall exercise all necessary and reasonable steps to ensure that MBEs participate in at least the percent of the contract as set forth above.
- (2) *If the anticipated MBE participation is zero*, the Contractor shall make an effort to recruit and use MBEs during the performance of the contract. Any MBE participation obtained shall be reported to the Department.

(B) **Women Business Enterprises 3.0 %**

- (1) *If the anticipated WBE participation is more than zero*, the Contractor shall exercise all necessary and reasonable steps to ensure that WBEs participate in at least the percent of the contract as set forth above.
- (2) *If the anticipated WBE participation is zero*, the Contractor shall make an effort to recruit and use WBEs during the performance of the contract. Any WBE participation obtained shall be reported to the Department.

The Bidder is required to submit only participation to meet the Combined MBE/WBE Goal. The Combined Goal may be met by submitting all MBE participation, all WBE participation, or a combination of MBE and WBE participation.

### **Directory of Transportation Firms (Directory)**

Real-time information is available about firms doing business with the Department and firms that are certified through NCUCP in the Directory of Transportation Firms. Only firms identified in the Directory as MBE and WBE certified shall be used to meet the Combined MBE/WBE Goal. The Directory can be found at the following link.

<https://www.ebs.nc.gov/VendorDirectory/default.html>

The listing of an individual firm in the directory shall not be construed as an endorsement of the firm's capability to perform certain work.

### **Listing of MBE/WBE Subcontractors**

At the time of bid, bidders shall submit all MBE and WBE participation that they anticipate to use during the life of the contract. Only those identified to meet the Combined MBE/WBE Goal will be considered committed, even though the listing shall include both committed MBE/WBE subcontractors and additional MBE/WBE subcontractors. Any additional MBE/WBE subcontractor participation above the goal will follow the banking guidelines found elsewhere in this provision. All other additional MBE/WBE subcontractor participation submitted at the time of bid will be used toward the Department's overall race-neutral goals. Only those firms with current MBE and WBE certification at the time of bid opening will be acceptable for listing in the bidder's submittal of MBE and WBE participation. The Contractor shall indicate the following required information:

#### **(A) Electronic Bids**

Bidders shall submit a listing of MBE and WBE participation in the appropriate section of the electronic submittal file.

- (1) Submit the names and addresses of MBE and WBE firms identified to participate in the contract. If the bidder uses the updated listing of MBE and WBE firms shown in the electronic submittal file, the bidder may use the dropdown menu to access the name and address of the firms.
- (2) Submit the contract line numbers of work to be performed by each MBE and WBE firm. When no figures or firms are entered, the bidder will be considered to have no MBE or WBE participation.
- (3) The bidder shall be responsible for ensuring that the MBE and WBE are certified at the time of bid by checking the Directory of Transportation Firms. If the firm is not certified at the time of the bid-letting, that MBE's or WBE's participation will not count towards achieving the Combined MBE/WBE goal.

#### **(B) Paper Bids**

- (1) *If the Combined MBE/WBE Goal is more than zero,*
  - (a) Bidders, at the time the bid proposal is submitted, shall submit a listing of MBE/WBE participation, including the names and addresses on *Listing of MBE and WBE Subcontractors* contained elsewhere in the contract documents in order for the bid to be considered responsive. Bidders shall indicate the total dollar value of the MBE and WBE participation for the contract.

- (b) If bidders have no MBE or WBE participation, they shall indicate this on the *Listing of MBE and WBE Subcontractors* by entering the word “None” or the number “0.” This form shall be completed in its entirety. **Blank forms will not be deemed to represent zero participation.** Bids submitted that do not have MBE and WBE participation indicated on the appropriate form will not be read publicly during the opening of bids. The Department will not consider these bids for award and the proposal will be rejected.
- (c) The bidder shall be responsible for ensuring that the MBE/WBE is certified at the time of bid by checking the Directory of Transportation Firms. If the firm is not certified at the time of the bid-letting, that MBE’s or WBE’s participation will not count towards achieving the Combined MBE/WBE Goal.
- (2) *If the Combined MBE/WBE Goal is zero, entries on the Listing of MBE and WBE Subcontractors are not required for the zero goal, however any MBE or WBE participation that is achieved during the project shall be reported in accordance with requirements contained elsewhere in the special provision.*

### **MBE or WBE Prime Contractor**

When a certified MBE or WBE firm bids on a contract that contains a Combined MBE/WBE goal, the firm is responsible for meeting the goal or making good faith efforts to meet the goal, just like any other bidder. In most cases, a MBE or WBE bidder on a contract will meet the Combined MBE/WBE Goal by virtue of the work it performs on the contract with its own forces. However, all the work that is performed by the MBE or WBE bidder and any other similarly certified subcontractors will count toward the goal. The MBE or WBE bidder shall list itself along with any MBE or WBE subcontractors, if any, in order to receive credit toward the goal.

MBE/WBE prime contractors shall also follow Sections A and B listed under *Listing of MBE/WBE Subcontractor* just as a non-MBE/WBE bidder would.

### **Written Documentation – Letter of Intent**

The bidder shall submit written documentation for each MBE/WBE that will be used to meet the Combined MBE/WBE Goal of the contract, indicating the bidder’s commitment to use the MBE/WBE in the contract. This documentation shall be submitted on the Department’s form titled *Letter of Intent*.

The documentation shall be received in the office of the State Contractor Utilization Engineer or at DBE@ncdot.gov no later than 10:00 a.m. of the sixth calendar day following opening of bids, unless the sixth day falls on an official state holiday. In that situation, it is due in the office of the State Contractor Utilization Engineer no later than 10:00 a.m. on the next official state business day.

If the bidder fails to submit the Letter of Intent from each committed MBE and WBE to be used toward the Combined MBE/WBE Goal, or if the form is incomplete (i.e. both signatures are not

present), the MBE/WBE participation will not count toward meeting the Combined MBE/WBE Goal. If the lack of this participation drops the commitment below the Combined MBE/WBE Goal, the Contractor shall submit evidence of good faith efforts for the goal, completed in its entirety, to the State Contractor Utilization Engineer or DBE@ncdot.gov no later than 10:00 a.m. on the eighth calendar day following opening of bids, unless the eighth day falls on an official state holiday. In that situation, it is due in the office of the State Contractor Utilization Engineer no later than 10:00 a.m. on the next official state business day.

### **Banking MBE/WBE Credit**

If the bid of the lowest responsive bidder exceeds \$500,000 and if the committed MBE/WBE participation submitted exceeds the algebraic sum of the Combined MBE /WBE Goal by \$1,000 or more, the excess will be placed on deposit by the Department for future use by the bidder. Separate accounts will be maintained for MBE and WBE participation and these may accumulate for a period not to exceed 24 months.

When the apparent lowest responsive bidder fails to submit sufficient participation by MBE and WBE firms to meet the advertised goal, as part of the good faith effort, the Department will consider allowing the bidder to withdraw funds to meet the Combined MBE/WBE Goal as long as there are adequate funds available from the bidder's MBE and WBE bank accounts.

### **Submission of Good Faith Effort**

If the bidder fails to meet or exceed the Combined MBE/WBE Goal, the apparent lowest responsive bidder shall submit to the Department documentation of adequate good faith efforts made to reach that specific goal.

A hard copy and an electronic copy of this information shall be received in the office of the State Contractor Utilization Engineer or at DBE@ncdot.gov no later than 10:00 a.m. on the sixth calendar day following opening of bids unless the sixth day falls on an official state holiday. In that situation, it would be due in the office of the State Contractor Utilization Engineer no later than 10:00 a.m. on the next official state business day. If the Contractor cannot send the information electronically, then one complete set and 5 copies of this information shall be received under the same time constraints above.

Note: Where the information submitted includes repetitious solicitation letters, it will be acceptable to submit a representative letter along with a distribution list of the firms that were solicited. Documentation of MBE/WBE quotations shall be a part of the good faith effort submittal. This documentation may include written subcontractor quotations, telephone log notations of verbal quotations, or other types of quotation documentation.

**Consideration of Good Faith Effort for Projects with a Combined MBE/WBE Goal More Than Zero**

Adequate good faith efforts mean that the bidder took all necessary and reasonable steps to achieve the goal which, by their scope, intensity, and appropriateness, could reasonably be expected to obtain sufficient MBE/WBE participation. Adequate good faith efforts also mean that the bidder actively and aggressively sought MBE/WBE participation. Mere *pro forma* efforts are not considered good faith efforts.

The Department will consider the quality, quantity, and intensity of the different kinds of efforts a bidder has made. Listed below are examples of the types of actions a bidder will take in making a good faith effort to meet the goals and are not intended to be exclusive or exhaustive, nor is it intended to be a mandatory checklist.

- (A) Soliciting through all reasonable and available means (e.g. attendance at pre-bid meetings, advertising, written notices, use of verifiable electronic means through the use of the NCDOT Directory of Transportation Firms) the interest of all certified MBEs/WBEs that are also prequalified subcontractors. The bidder must solicit this interest within at least 10 days prior to bid opening to allow the MBEs/WBEs to respond to the solicitation. Solicitation shall provide the opportunity to MBEs/WBEs within the Division and surrounding Divisions where the project is located. The bidder must determine with certainty if the MBEs/WBEs are interested by taking appropriate steps to follow up initial solicitations.
- (B) Selecting portions of the work to be performed by MBEs/WBEs in order to increase the likelihood that the Combined MBE/WBE Goal will be achieved.
  - (1) Where appropriate, break out contract work items into economically feasible units to facilitate MBE/WBE participation, even when the prime contractor might otherwise prefer to perform these work items with its own forces.
  - (2) Negotiate with subcontractors to assume part of the responsibility to meet the advertised goal when the work to be sublet includes potential for MBE/WBE participation (2<sup>nd</sup> and 3<sup>rd</sup> tier subcontractors).
- (C) Providing interested certified MBEs/WBEs that are also prequalified subcontractors with adequate information about the plans, specifications, and requirements of the contract in a timely manner to assist them in responding to a solicitation.
- (D) (1) Negotiating in good faith with interested MBEs/WBEs. It is the bidder's responsibility to make a portion of the work available to MBE/WBE subcontractors and suppliers and to select those portions of the work or material needs consistent with the available MBE/WBE subcontractors and suppliers, so as to facilitate MBE/WBE participation. Evidence of such negotiation includes the names, addresses, and telephone numbers of MBEs/WBEs that were considered; a description of the information provided regarding the plans and specifications

for the work selected for subcontracting; and evidence as to why additional agreements could not be reached for MBEs/WBEs to perform the work.

- (2) A bidder using good business judgment would consider a number of factors in negotiating with subcontractors, including MBE/WBE subcontractors, and would take a firm's price and capabilities as well as the advertised goal into consideration. However, the fact that there may be some additional costs involved in finding and using MBEs/WBEs is not in itself sufficient reason for a bidder's failure to meet the contract goal, as long as such costs are reasonable. Also, the ability or desire of a prime contractor to perform the work of a contract with its own organization does not relieve the bidder of the responsibility to make good faith efforts. Bidding contractors are not, however, required to accept higher quotes from MBEs/WBEs if the price difference is excessive or unreasonable.
- (E) Not rejecting MBEs/WBEs as being unqualified without sound reasons based on a thorough investigation of their capabilities. The bidder's standing within its industry, membership in specific groups, organizations, or associates and political or social affiliations (for example, union vs. non-union employee status) are not legitimate causes for the rejection or non-solicitation of bids in the bidder's efforts to meet the project goal.
- (F) Making efforts to assist interested MBEs/WBEs in obtaining bonding, lines of credit, or insurance as required by the recipient or bidder.
- (G) Making efforts to assist interested MBEs/WBEs in obtaining necessary equipment, supplies, materials, or related assistance or services.
- (H) Effectively using the services of available minority/women community organizations; minority/women contractors' groups; Federal, State, and local minority/women business assistance offices; and other organizations as allowed on a case-by-case basis to provide assistance in the recruitment and placement of MBEs/WBEs. Contact within 7 days from the bid opening the Business Opportunity and Work Force Development Unit at BOWD@ncdot.gov to give notification of the bidder's inability to get MBE or WBE quotes.
- (I) Any other evidence that the bidder submits which shows that the bidder has made reasonable good faith efforts to meet the advertised goal.

In addition, the Department may take into account the following:

- (1) Whether the bidder's documentation reflects a clear and realistic plan for achieving the Combined MBE/WBE Goal.
- (2) The bidders' past performance in meeting the contract goal.
- (3) The performance of other bidders in meeting the advertised goal. For example, when the apparent successful bidder fails to meet the goal, but others meet it, you may reasonably raise the question of whether, with additional reasonable efforts

the apparent successful bidder could have met the goal. If the apparent successful bidder fails to meet the advertised goal, but meets or exceeds the average MBE and WBE participation obtained by other bidders, the Department may view this, in conjunction with other factors, as evidence of the apparent successful bidder having made a good faith effort.

If the Department does not award the contract to the apparent lowest responsive bidder, the Department reserves the right to award the contract to the next lowest responsive bidder that can satisfy to the Department that the Combined MBE/WBE Goal can be met or that an adequate good faith effort has been made to meet the advertised goal.

### **Non-Good Faith Appeal**

The State Prequalification Engineer will notify the Contractor verbally and in writing of non-good faith. A Contractor may appeal a determination of non-good faith made by the Goal Compliance Committee. If a Contractor wishes to appeal the determination made by the Committee, they shall provide written notification to the State Prequalification Engineer. The appeal shall be made within 2 business days of notification of the determination of non-good faith.

### **Counting MBE/WBE Participation Toward Meeting the Combined MBE/WBE Goal**

#### **(A) Participation**

The total dollar value of the participation by a committed MBE/WBE will be counted toward the contract goal requirements. The total dollar value of participation by a committed MBE/WBE will be based upon the value of work performed by the MBE/WBE and the actual payments to MBE/WBE firms by the Contractor.

#### **(B) Joint Checks**

Prior notification of joint check use shall be required when counting MBE/WBE participation for services or purchases that involves the use of a joint check. Notification shall be through submission of Form JC-1 (*Joint Check Notification Form*) and the use of joint checks shall be in accordance with the Department's Joint Check Procedures.

#### **(C) Subcontracts (Non-Trucking)**

A MBE/WBE may enter into subcontracts. Work that a MBE subcontracts to another MBE firm may be counted toward the anticipated MBE participation. The same holds true for work that a WBE subcontracts to another WBE firm. Work that a MBE/WBE subcontracts to a non-MBE/WBE firm does not count toward the contract goal requirement. It should be noted that every effort shall be made by MBE and WBE contractors to subcontract to the same certification (i.e., MBEs to MBEs and WBEs to WBEs), in order to fulfill the MBE or WBE participation breakdown. This, however, may not always be possible due to the limitation of firms in the area. If the MBE or WBE firm shows a good faith effort has been made to reach out to similarly certified

firms and there is no interest or availability, and they can get assistance from other certified firms, the Engineer will not hold the prime responsible for meeting the individual MBE or WBE breakdown. If a MBE or WBE contractor or subcontractor subcontracts a significantly greater portion of the work of the contract than would be expected on the basis of standard industry practices, it shall be presumed that the MBE or WBE is not performing a commercially useful function.

(D) Joint Venture

When a MBE or WBE performs as a participant in a joint venture, the Contractor may count toward its contract goal requirement a portion of the total value of participation with the MBE or WBE in the joint venture, that portion of the total dollar value being a distinct clearly defined portion of work that the MBE or WBE performs with its forces.

(F) Manufacturer, Regular Dealer, Distributor

A Contractor may count toward its MBE/WBE requirement 40 percent of its expenditures for materials or supplies (including transportation costs) from a MBE/WBE distributor, 60 percent of its expenditures for materials or supplies (including transportation costs) from a MBE/WBE regular dealer and 100 percent of such expenditures obtained from a MBE/WBE manufacturer.

A Contractor may count toward its MBE/WBE requirement the following expenditures to MBE/WBE firms that are not manufacturers, regular dealers or distributors:

- (1) The fees or commissions charged by a MBE/WBE firm for providing a *bona fide* service, such as professional, technical, consultant, or managerial services, or for providing bonds or insurance specifically required for the performance of a DOT-assisted contract, provided the fees or commissions are determined to be reasonable and not excessive as compared with fees and commissions customarily allowed for similar services.
- (2) With respect to materials or supplies purchased from a MBE/WBE, which is neither a manufacturer, regular dealer, nor a distributor count the entire amount of fees or commissions charged that the Department deems to be reasonable, including transportation charges for the delivery of materials or supplies. Do not count any portion of the cost of the materials and supplies themselves.

A Contractor will submit a completed *DBE Regular Dealer/Distributor Affirmation Form* with the Letter of Intent to the State Contractor Utilization Engineer or [DBE@ncdot.gov](mailto:DBE@ncdot.gov). The State Contractor Utilization Engineer will make a preliminary assessment as to whether a MBE/WBE supplier has the demonstrated capacity to perform a commercially useful function (CUF) on a contract-by-contract basis *prior* to its participation.



**Commercially Useful Function****(A) MBE/WBE Utilization**

The Contractor may count toward its contract goal requirement only expenditures to MBEs and WBEs that perform a commercially useful function in the work of a contract. A MBE/WBE performs a commercially useful function when it is responsible for execution of the work of the contract and is carrying out its responsibilities by performing, managing, and supervising the work involved. To perform a commercially useful function, the MBE/WBE shall also be responsible with respect to materials and supplies used on the contract, for negotiating price, determining quality and quantity, ordering the material and installing (where applicable) and paying for the material itself. To determine whether a MBE/WBE is performing a commercially useful function, the Department will evaluate the amount of work subcontracted, industry practices, whether the amount the firm is to be paid under the contract is commensurate with the work it is performing and the MBE/WBE credit claimed for its performance of the work, and any other relevant factors. If it is determined that a MBE or WBE is not performing a Commercially Useful Function, the contractor may present evidence to rebut this presumption to the Department.

**(B) MBE/WBE Utilization in Trucking**

The following factors will be used to determine if a MBE or WBE trucking firm is performing a commercially useful function:

- (1) The MBE/WBE shall be responsible for the management and supervision of the entire trucking operation for which it is responsible on a particular contract, and there shall not be a contrived arrangement for the purpose of meeting the Combined MBE/WBE Goal.
- (2) The MBE/WBE shall itself own and operate at least one fully licensed, insured, and operational truck used on the contract.
- (3) The MBE/WBE receives credit for the total value of the transportation services it provides on the contract using trucks it owns, insures, and operates using drivers it employs.
- (4) The MBE may subcontract the work to another MBE firm, including an owner-operator who is certified as a MBE. The same holds true that a WBE may subcontract the work to another WBE firm, including an owner-operator who is certified as a WBE. When this occurs, the MBE or WBE who subcontracts work receives credit for the total value of the transportation services the subcontracted MBE or WBE provides on the contract. It should be noted that every effort shall be made by MBE and WBE contractors to subcontract to the same certification (i.e., MBEs to MBEs and WBEs to WBEs), in order to fulfill the participation breakdown. This, however, may not always be possible due to the limitation of firms in the area. If the MBE or WBE firm shows a good faith

effort has been made to reach out to similarly certified transportation service providers and there is no interest or availability, and they can get assistance from other certified providers, the Engineer will not hold the prime responsible for meeting the individual MBE or WBE participation breakdown.

- (5) The MBE/WBE may also subcontract the work to a non-MBE/WBE firm, including from an owner-operator. The MBE/WBE who subcontracts the work to a non-MBE/WBE is entitled to credit for the total value of transportation services provided by the non-MBE/WBE subcontractor not to exceed the value of transportation services provided by MBE/WBE-owned trucks on the contract. Additional participation by non-MBE/WBE subcontractors receives credit only for the fee or commission it receives as a result of the subcontract arrangement. The value of services performed under subcontract agreements between the MBE/WBE and the Contractor will not count towards the MBE/WBE contract requirement.
- (6) A MBE/WBE may lease truck(s) from an established equipment leasing business open to the general public. The lease must indicate that the MBE/WBE has exclusive use of and control over the truck. This requirement does not preclude the leased truck from working for others during the term of the lease with the consent of the MBE/WBE, so long as the lease gives the MBE/WBE absolute priority for use of the leased truck. This type of lease may count toward the MBE/WBE's credit as long as the driver is under the MBE/WBE's payroll.
- (7) Subcontracted/leased trucks shall display clearly on the dashboard the name of the MBE/WBE that they are subcontracted/leased to and their own company name if it is not identified on the truck itself. Magnetic door signs are not permitted.

### **MBE/WBE Replacement**

When a Contractor has relied on a commitment to a MBE or WBE subcontractor (or an approved substitute MBE or WBE subcontractor) to meet all or part of a contract goal requirement, the contractor shall not terminate the MBE/WBE subcontractor or any portion of its work for convenience. This includes, but is not limited to, instances in which the Contractor seeks to perform the work of the terminated subcontractor with another MBE/WBE subcontractor, a non-MBE/WBE subcontractor, or with the Contractor's own forces or those of an affiliate.

The Contractor must give notice in writing both by certified mail and email to the MBE/WBE subcontractor, with a copy to the Engineer of its intent to request to terminate a MBE/WBE subcontractor or any portion of its work, and the reason for the request. The Contractor must give the MBE/WBE subcontractor five (5) business days to respond to the Contractor's Notice of Intent to Request Termination and/or Substitution. If the MBE/WBE subcontractor objects to the intended termination/substitution, the MBE/WBE, within five (5) business days must advise the Contractor and the Department of the reasons why the action should not be approved. The five-day notice period shall begin on the next business day after written notice is provided to the MBE/WBE subcontractor.

A committed MBE/WBE subcontractor may only be terminated or any portion of its work after receiving the Department's written approval based upon a finding of good cause for the proposed termination and/or substitution. Good cause does not exist if the Contractor seeks to terminate a MBE/WBE or any portion of its work that it relied upon to obtain the contract so that the Contractor can self-perform the work for which the MBE/WBE was engaged, or so that the Contractor can substitute another MBE/WBE or non- MBE/WBE contractor after contract award. For purposes of this section, good cause shall include the following circumstances:

- (a) The listed MBE/WBE subcontractor fails or refuses to execute a written contract;
- (b) The listed MBE/WBE subcontractor fails or refuses to perform the work of its subcontract in a way consistent with normal industry standards. Provided, however, that good cause does not exist if the failure or refusal of the MBE/WBE subcontractor to perform its work on the subcontract results from the bad faith or discriminatory action of the prime contractor;
- (c) The listed MBE/WBE subcontractor fails or refuses to meet the prime contractor's reasonable, nondiscriminatory bond requirements;
- (d) The listed MBE/WBE subcontractor becomes bankrupt, insolvent, or exhibits credit unworthiness;
- (e) The listed MBE/WBE subcontractor is ineligible to work on public works projects because of suspension and debarment proceedings pursuant to 2 CFR parts 180, 215 and 1200 or applicable State law;
- (f) The listed MBE/WBE subcontractor is not a responsible contractor;
- (g) The listed MBE/WBE voluntarily withdraws from the project and provides written notice of withdrawal;
- (h) The listed MBE/WBE is ineligible to receive MBE/WBE credit for the type of work required;
- (i) A MBE/WBE owner dies or becomes disabled with the result that the listed MBE/WBE contractor is unable to complete its work on the contract; and
- (j) Other documented good cause that compels the termination of the MBE/WBE subcontractor.

The Contractor shall comply with the following for replacement of a committed MBE/WBE:

(A) Performance Related Replacement

When a committed MBE/WBE is terminated for good cause as stated above, an additional MBE/WBE that was submitted at the time of bid may be used to fulfill the MBE/WBE commitment to meet the Combined MBE/WBE Goal. A good faith effort will only be required for removing a committed MBE/WBE if there were no additional MBE/WBEs submitted at the time of bid to cover the same amount of work as the MBE/WBE that was terminated.

If a replacement MBE/WBE is not found that can perform at least the same amount of work as the terminated MBE/WBE, the Contractor shall submit a good faith effort documenting the steps taken. Such documentation shall include, but not be limited to, the following:

- (1) Copies of written notification to MBE/WBEs that their interest is solicited in contracting the work defaulted by the previous MBE/WBE or in subcontracting other items of work in the contract.
  - (2) Efforts to negotiate with MBE/WBEs for specific subbids including, at a minimum:
    - (a) The names, addresses, and telephone numbers of MBE/WBEs who were contacted.
    - (b) A description of the information provided to MBE/WBEs regarding the plans and specifications for portions of the work to be performed.
  - (3) A list of reasons why MBE/WBE quotes were not accepted.
  - (4) Efforts made to assist the MBE/WBEs contacted, if needed, in obtaining bonding or insurance required by the Contractor.
- (B) Decertification Replacement
- (1) When a committed MBE/WBE is decertified by the Department after the SAF (*Subcontract Approval Form*) has been received by the Department, the Department will not require the Contractor to solicit replacement MBE/WBE participation equal to the remaining work to be performed by the decertified firm. The participation equal to the remaining work performed by the decertified firm will count toward the contract goal requirement but not the overall goal.
    - (i) If the MBE/WBE's ineligibility is caused solely by its having exceeded the size standard during the performance of the contract. The Department may continue to count participation equal to the remaining work performed by the decertified firm which will count toward the contract goal requirement and overall goal.
    - (ii) If the MBE/WBE's ineligibility is caused solely by its acquisition by or merger with a non- MBE/WBE during the performance of the contract. The Department may not continue to count the portion of the decertified firm's performance on the contract remaining toward either the contract goal or the overall goal, even if the Contractor has executed a subcontract with the firm or the Department has executed a prime contract with the MBE/WBE that was later decertified.
  - (2) When a committed MBE/WBE is decertified prior to the Department receiving the SAF (*Subcontract Approval Form*) for the named MBE/WBE firm, the

Contractor shall take all necessary and reasonable steps to replace the MBE/WBE subcontractor with another MBE/WBE subcontractor to perform at least the same amount of work to meet the Combined MBE/WBE goal requirement. If a MBE/WBE firm is not found to do the same amount of work, a good faith effort must be submitted to NCDOT (see A herein for required documentation).

All requests for replacement of a committed MBE/WBE firm shall be submitted to the Engineer for approval on Form RF-1 (*DBE Replacement Request*). If the Contractor fails to follow this procedure, the Contractor may be disqualified from further bidding for a period of up to 6 months.

### **Changes in the Work**

When the Engineer makes changes that result in the reduction or elimination of work to be performed by a committed MBE/WBE, the Contractor will not be required to seek additional participation. When the Engineer makes changes that result in additional work to be performed by a MBE/WBE based upon the Contractor's commitment, the MBE/WBE shall participate in additional work to the same extent as the MBE/WBE participated in the original contract work.

When the Engineer makes changes that result in extra work, which has more than a minimal impact on the contract amount, the Contractor shall seek additional participation by MBEs/WBEs unless otherwise approved by the Engineer.

When the Engineer makes changes that result in an alteration of plans or details of construction, and a portion or all of the work had been expected to be performed by a committed MBE/WBE, the Contractor shall seek participation by MBEs/WBEs unless otherwise approved by the Engineer.

When the Contractor requests changes in the work that result in the reduction or elimination of work that the Contractor committed to be performed by a MBE/WBE, the Contractor shall seek additional participation by MBEs/WBEs equal to the reduced MBE/WBE participation caused by the changes.

### **Reports and Documentation**

A SAF (*Subcontract Approval Form*) shall be submitted for all work which is to be performed by a MBE/WBE subcontractor. The Department reserves the right to require copies of actual subcontract agreements involving MBE/WBE subcontractors.

When using transportation services to meet the contract commitment, the Contractor shall submit a proposed trucking plan in addition to the SAF. The plan shall be submitted prior to beginning construction on the project. The plan shall include the names of all trucking firms proposed for use, their certification type(s), the number of trucks owned by the firm, as well as the individual truck identification numbers, and the line item(s) being performed.

Within 30 calendar days of entering into an agreement with a MBE/WBE for materials, supplies or services, not otherwise documented by the SAF as specified above, the Contractor shall

furnish the Engineer a copy of the agreement. The documentation shall also indicate the percentage (60% or 100%) of expenditures claimed for MBE/WBE credit.

### **Reporting Minority and Women Business Enterprise Participation**

The Contractor shall provide the Engineer with an accounting of payments made to all MBE/WBE firms, including material suppliers and contractors at all levels (prime, subcontractor, or second tier subcontractor). This accounting shall be furnished to the Engineer for any given month by the end of the following month. Failure to submit this information accordingly may result in the following action:

- (A) Withholding of money due in the next partial pay estimate; or
- (B) Removal of an approved contractor from the prequalified bidders' list or the removal of other entities from the approved subcontractors list.

While each contractor (prime, subcontractor, 2nd tier subcontractor) is responsible for accurate accounting of payments to MBEs/WBEs, it shall be the prime contractor's responsibility to report all monthly and final payment information in the correct reporting manner.

Failure on the part of the Contractor to submit the required information in the time frame specified may result in the disqualification of that contractor and any affiliate companies from further bidding until the required information is submitted.

Failure on the part of any subcontractor to submit the required information in the time frame specified may result in the disqualification of that contractor and any affiliate companies from being approved for work on future DOT projects until the required information is submitted.

Contractors reporting transportation services provided by non-MBE/WBE lessees shall evaluate the value of services provided during the month of the reporting period only.

At any time, the Engineer can request written verification of subcontractor payments.

The Contractor shall report the accounting of payments through the Department's Payment Tracking System.

### **Failure to Meet Contract Requirements**

Failure to meet contract requirements in accordance with Subarticle 102-15(J) of the *Standard Specifications* may be cause to disqualify the Contractor.

**RESTRICTIONS ON ITS EQUIPMENT AND SERVICES:**

(11-17-20)

SP01 G090

All telecommunications, video or other ITS equipment or services installed or utilized on this project must be in conformance with UNIFORM ADMINISTRATIVE REQUIREMENTS, COST PRINCIPLES, AND AUDIT REQUIREMENTS FOR FEDERAL AWARDS **2 CFR, § 200.216 Prohibition on certain telecommunications and video surveillance services or equipment.**

**USE OF UNMANNED AIRCRAFT SYSTEM (UAS):**

(8-20-19)

SP1 G092

The Contractor shall adhere to all Federal, State and Local regulations and guidelines for the use of Unmanned Aircraft Systems (UAS). This includes but is not limited to US 14 CFR Part 107 *Small UAS Rule*, NC GS 15A-300.2 *Regulation of launch and recovery sites*, NC GS 63-95 *Training required for the operation of unmanned aircraft systems*, NC GS 63-96 *Permit required for commercial operation of unmanned aircraft system*, and NCDOT UAS Policy. The required operator certifications include possessing a current Federal Aviation Administration (FAA) Remote Pilot Certificate, a NC UAS Operator Permit as well as operating a UAS registered with the FAA.

Prior to beginning operations, the Contractor shall complete the NCDOT UAS – Flight Operation Approval Form and submit it to the Engineer for approval. All UAS operations shall be approved by the Engineer prior to beginning the operations.

All contractors or subcontractors operating UAS shall have UAS specific general liability insurance to cover all operations under this contract.

The use of UAS is at the Contractor's discretion. No measurement or payment will be made for the use of UAS. In the event that the Department directs the Contractor to utilize UAS, payment will be in accordance with Article 104-7 Extra Work.

**EQUIPMENT IDLING GUIDELINES:**

(1-19-21)

107

SP1 G096

Exercise reduced fuel consumption and reduced equipment emissions during the construction of all work associated with this contract. Employees engaged in the construction of this project should turn off vehicles when stopped for more than thirty (30) minutes and off-highway equipment should idle no longer than fifteen (15) consecutive minutes.

These guidelines for turning off vehicles and equipment when idling do not apply to:

1. Idling when queuing.
2. Idling to verify the vehicle is in safe operating condition.
3. Idling for testing, servicing, repairing or diagnostic purposes.
4. Idling necessary to accomplish work for which the vehicle was designed (such as operating a crane, mixing concrete, etc.).
5. Idling required to bring the machine system to operating temperature.

6. Emergency vehicles, utility company, construction, and maintenance vehicles where the engines must run to perform needed work.
7. Idling to ensure safe operation of the vehicle.
8. Idling when the propulsion engine is providing auxiliary power for other than heating or air conditioning. (such as hydraulic systems for pavers)
9. When specific traffic, safety, or emergency situations arise.
10. If the ambient temperature is less than 32 degrees Fahrenheit. Limited idling to provide for the safety of vehicle occupants (e.g. to run the heater).
11. If the ambient temperature is greater than 90 degrees Fahrenheit. Limited idling to provide for the safety of vehicle occupants of off-highway equipment (e.g. to run the air conditioning) no more than 30 minutes.
12. Diesel powered vehicles may idle for up to 30 minutes to minimize restart problems.

Any vehicle, truck, or equipment in which the primary source of fuel is natural gas or electricity is exempt from the idling limitations set forth in this special provision.

**SUBSURFACE INFORMATION:**

(7-1-95)

450

SP1 G112 C

Subsurface information is available on the roadway and structure portions of this project.

**MAINTENANCE OF THE PROJECT:**

(11-20-07)(Rev. 1-16-24)

104-10

SP1 G125

Revise the *Standard Specifications* as follows:

**Page 1-35, Article 104-10 Maintenance of the Project, line 3,** add the following after the first sentence of the first paragraph:

All guardrail/guiderail within the project limits shall be included in this maintenance.

**Page 1-35, Article 104-10 MAINTENANCE OF THE PROJECT, line 8,** add the following as the last sentence of the first paragraph:

The Contractor shall perform weekly inspections of guardrail and guiderail and shall report damages to the Engineer on the same day of the weekly inspection. *Where damaged guardrail or guiderail is repaired or replaced as a result of maintaining the project in accordance with this article, such repair or replacement shall be performed within 7 consecutive calendar days of such inspection report.*

**Page 1-35, Article 104-10 MAINTENANCE OF THE PROJECT, lines 20-22,** replace the last sentence of the last paragraph with the following:

The Contractor will not be directly compensated for any maintenance operations necessary, except for maintenance of guardrail/guiderail, as this work will be considered incidental to the work covered by the various contract items. The provisions of Article 104-7, Extra Work, and Article 104-8, Compensation and Record Keeping will apply to authorized maintenance of guardrail/guiderail. Performance of weekly inspections of guardrail/guiderail, and the damage



reports required as described above, will be considered to be an incidental part of the work being paid for by the various contract items.

**COOPERATION BETWEEN CONTRACTORS:**

(7-1-95)(Rev. 1-16-24)

105-7

SP1 G133

The Contractor's attention is directed to Article 105-7 of the *Standard Specifications*.

U-2519BA / U-2519BB (C204110) is located adjacent to this project. C204110 is currently under construction and not anticipated to be completed prior to the letting of this project.

U-3422B is located adjacent to this project and is anticipated for a December 16, 2025 Letting.

The Contractor on this project shall cooperate with the Contractor working within or adjacent to the limits of this project to the extent that the work can be carried out to the best advantage of all concerned.

**BID DOCUMENTATION:**

(1-1-02) (Rev.8-20-24)

103

SP1 G142

**General**

The successful Bidder (Contractor) shall submit the original, unaltered bid documentation or a certified copy of the original, unaltered bid documentation used to prepare the bid for this contract to the Department within 10 days after receipt of notice of award of contract. Such documentation shall be placed in escrow with a banking institution or other bonded document storage facility selected by the Department.

The Department will not execute the contract until the original, unaltered bid documentation or a certified copy of the original, unaltered bid documentation has been received by the Department.

**Terms**

*Bid Documentation* - Bid Documentation shall mean all written information, working papers, computer printouts, electronic media, charts, and all other data compilations which contain or reflect information, data, and calculations used by the Bidder in the preparation of the bid. The term *bid documentation* includes, but is not limited to, contractor equipment rates, contractor overhead rates, labor rates, efficiency or productivity factors, arithmetical calculations, and quotations from subcontractors and material suppliers to the extent that such rates and quotations were used by the Bidder in formulating and determining the bid. The term *bid documentation* also includes any manuals, which are standard to the industry used by the Bidder in determining the bid. Such manuals may be included in the bid documentation by reference. Such reference shall include the name and date of the publication and the publisher. *Bid Documentation* does not include bid documents provided by the Department for use by the Bidder in bidding on this project. The Bid Documentation can be in the form of electronic submittal (i.e. thumb drive) or paper. If the Bidder elects to submit the Bid Documentation in electronic format, the Department requires a backup submittal (i.e. a second thumb drive) in case one is corrupted.

*Contractor's Representative* - Officer of the Contractor's company; if not an officer, the Contractor shall supply a letter signed and notarized by an officer of the Contractor's company, granting permission for the representative to sign the escrow agreement on behalf of the Contractor.

*Escrow Agent* - Officer of the select banking institution or other bonded document storage facility authorized to receive and release bid documentation.

### **Escrow Agreement Information**

A draft copy of the Escrow Agreement will be mailed to the Bidder after the notice of award for informational purposes. The Bidder and Department will sign the actual Escrow Agreement at the time the bid documentation is delivered to the Escrow Agent.

### **Failure to Provide Bid Documentation**

The Bidder's failure to provide the original, unaltered bid documentation or a certified copy of the original, unaltered bid documentation within 14 days after the notice of award is received may be just cause for rescinding the award of the contract and may result in the removal of the Bidder from the Department's list of qualified bidders for a period of up to 180 days. Award may then be made to the next lowest responsible bidder or the work may be readvertised and constructed under the contract or otherwise, as the Department may decide.

### **Submittal of Bid Documentation**

- (A) Appointment – Email specs@ncdot.gov or call 919.707.6900 to schedule an appointment.
- (B) Delivery - A representative of the Bidder shall deliver the original, unaltered bid documentation or a certified copy of the original, unaltered bid documentation to the Department, in a container suitable for sealing, within 10 days after the notice of award is received.
- (C) Packaging – The container shall be no larger than 15.5 inches in length by 12 inches wide by 11 inches high and shall be water resistant. The container shall be clearly marked on the face and the back of the container with the following information: Bid Documentation, Bidder's Name, Bidder's Address, Date of Escrow Submittal, Contract Number, TIP Number if applicable, and County.

### **Affidavit**

Bid documentation will be considered a certified copy if the Bidder includes an affidavit stating that the enclosed documentation is an EXACT copy of the original documentation used by the Bidder to determine the bid for this project. The affidavit shall also list each bid document with sufficient specificity so a comparison may be made between the list and the bid documentation to ensure that all of the bid documentation listed in the affidavit has been enclosed for escrow. The affidavit shall attest that the affiant has personally examined the bid documentation, that the affidavit lists all of the documents used by the Bidder to determine the bid for this project, and that all bid documentation has been included. The affidavit shall be signed by a chief officer of

the company, have the person's name and title typed below the signature, and the signature shall be notarized at the bottom of the affidavit.

### **Verification**

Upon delivery of the bid documentation, the State Contract Officer acting directly or through a duly authorized representative and the Bidder's representative will verify the accuracy and completeness of the bid documentation compared to the affidavit. Should a discrepancy exist, the Bidder's representative shall immediately furnish the State Contract Officer acting directly or through a duly authorized representative with any other needed bid documentation. The State Contract Officer acting directly or through a duly authorized representative upon determining that the bid documentation is complete will, in the presence of the Bidder's representative, immediately place the complete bid documentation and affidavit in the container and seal it. Both parties will deliver the sealed container to the Escrow Agent for placement in a safety deposit box, vault, or other secure accommodation.

### **Confidentiality of Bid Documentation**

The bid documentation and affidavit in escrow are, and will remain, the property of the Bidder. The Department has no interest in, or right to, the bid documentation and affidavit other than to verify the contents and legibility of the bid documentation unless the Contractor gives written notice of intent to file a claim, files a written claim, files a written and verified claim, or initiates litigation against the Department. In the event of such written notice of intent to file a claim, filing of a written claim, filing a written and verified claim, or initiation of litigation against the Department, or receipt of a letter from the Contractor authorizing release, the bid documentation and affidavit may become the property of the Department for use in considering any claim or in litigation as the Department may deem appropriate.

Any portion or portions of the bid documentation designated by the Bidder as a *trade secret* at the time the bid documentation is delivered to the State Contract Officer acting directly or through a duly authorized representative shall be protected from disclosure as provided by *G.S. 132-1.2*.

### **Duration and Use**

The bid documentation and affidavit shall remain in escrow until 60 calendar days from the time the Contractor receives the final estimate; or until such time as the Contractor:

- (A) Gives written notice of intent to file a claim,
- (B) Files a written claim,
- (C) Files a written and verified claim,
- (D) Initiates litigation against the Department related to the contract; or
- (E) Authorizes in writing its release.

Upon the giving of written notice of intent to file a claim, filing a written claim, filing a written and verified claim, or the initiation of litigation by the Contractor against the Department, or receipt of a letter from the Contractor authorizing release, the Department may obtain the release and custody of the bid documentation.

The Bidder certifies and agrees that the sealed container placed in escrow contains all of the bid documentation used to determine the bid and that no other bid documentation shall be relevant or material in litigation over claims brought by the Contractor arising out of this contract.

### **Release of Bid Documentation to the Contractor**

If the bid documentation remains in escrow 60 calendar days after the time the Contractor receives the final estimate and the Contractor has not filed a written claim, filed a written and verified claim, or has not initiated litigation against the Department related to the contract, the Department will instruct the Escrow Agent to release the sealed container to the Contractor.

The Contractor will be notified by certified letter from the Escrow Agent that the bid documentation will be released to the Contractor. The Contractor or his representative shall retrieve the bid documentation from the Escrow Agent within 30 days of the receipt of the certified letter. If the Contractor does not receive the documents within 30 days of the receipt of the certified letter, the Department will contact the Contractor to determine final dispersion of the bid documentation.

### **Payment**

The cost of the escrow will be borne by the Department. There will be no separate payment for all costs of compilation of the data, container, or verification of the bid documentation. Payment at the various contract unit or lump sum prices in the contract will be full compensation for all such costs.

### **TWELVE MONTH GUARANTEE:**

(7-15-03)

108

SP1 G145

- (A) The Contractor shall guarantee materials and workmanship against latent and patent defects arising from faulty materials, faulty workmanship or negligence for a period of twelve months following the date of final acceptance of the work for maintenance and shall replace such defective materials and workmanship without cost to the Department. The Contractor will not be responsible for damage due to faulty design, normal wear and tear, for negligence on the part of the Department, and/or for use in excess of the design.
- (B) Where items of equipment or material carry a manufacturer's guarantee for any period in excess of twelve months, then the manufacturer's guarantee shall apply for that particular piece of equipment or material. The Department's first remedy shall be through the manufacturer although the Contractor is responsible for invoking the warranted repair work with the manufacturer. The Contractor's responsibility shall be limited to the term of the manufacturer's guarantee. NCDOT would be afforded the same warranty as provided by the Manufacturer.

This guarantee provision shall be invoked only for major components of work in which the Contractor would be wholly responsible for under the terms of the contract. Examples would include pavement structures, bridge components, and sign structures. This provision will not be used as a mechanism to force the Contractor to return to the project to make repairs or perform additional work that the Department would normally compensate the Contractor for. In addition,

routine maintenance activities (i.e. mowing grass, debris removal, ruts in earth shoulders,) are not parts of this guarantee.

Appropriate provisions of the payment and/or performance bonds shall cover this guarantee for the project.

To ensure uniform application statewide the Division Engineer will forward details regarding the circumstances surrounding any proposed guarantee repairs to the Chief Engineer for review and approval prior to the work being performed.

**OUTSOURCING OUTSIDE THE USA:**

(9-21-04) (Rev. 5-16-06)

SP1 G150

All work on consultant contracts, services contracts, and construction contracts shall be performed in the United States of America. No work shall be outsourced outside of the United States of America.

*Outsourcing* for the purpose of this provision is defined as the practice of subcontracting labor, work, services, staffing, or personnel to entities located outside of the United States.

The North Carolina Secretary of Transportation shall approve exceptions to this provision in writing.

**EROSION AND SEDIMENT CONTROL/STORMWATER CERTIFICATION:**

(1-16-07) (Rev. 10-15-24)

105-16, 225-2, 16

SP1 G180

**General**

Schedule and conduct construction activities in a manner that will minimize soil erosion and the resulting sedimentation and turbidity of surface waters. Comply with the requirements herein regardless of whether or not a National Pollution discharge Elimination System (NPDES) permit for the work is required.

Establish a chain of responsibility for operations and subcontractors' operations to ensure that the *Erosion and Sediment Control/Stormwater Pollution Prevention Plan* is implemented and maintained over the life of the contract.

- (A) *Certified Supervisor* - Provide a certified Erosion and Sediment Control/Stormwater Supervisor to manage the Contractor and subcontractor operations, insure compliance with Federal, State and Local ordinances and regulations, and manage the Quality Control Program.
- (B) *Certified Foreman* - Provide a certified, trained foreman for each construction operation that increases the potential for soil erosion or the possible sedimentation and turbidity of surface waters.
- (C) *Certified Installer* - Provide a certified installer to install or direct the installation for erosion or sediment/stormwater control practices.

- (D) *Certified Designer* - Provide a certified designer for the design of the erosion and sediment control/stormwater component of reclamation plans and, if applicable, for the design of the project erosion and sediment control/stormwater plan.

### **Roles and Responsibilities**

- (A) *Certified Erosion and Sediment Control/Stormwater Supervisor* - The Certified Supervisor shall be Level II and responsible for ensuring the erosion and sediment control/stormwater plan is adequately implemented and maintained on the project and for conducting the quality control program. The Certified Supervisor shall be on the project within 24 hours notice from initial exposure of an erodible surface to the project's final acceptance. Perform the following duties:
- (1) **Manage Operations** - Coordinate and schedule the work of subcontractors so that erosion and sediment control/stormwater measures are fully executed for each operation and in a timely manner over the duration of the contract.
    - (a) Oversee the work of subcontractors so that appropriate erosion and sediment control/stormwater preventive measures are conformed to at each stage of the work.
    - (b) Prepare the required National Pollutant Discharge Elimination System (NPDES) Inspection Record and submit to the Engineer.
    - (c) Attend all weekly or monthly construction meetings to discuss the findings of the NPDES inspection and other related issues.
    - (d) Implement the erosion and sediment control/stormwater site plans requested.
    - (e) Provide any needed erosion and sediment control/stormwater practices for the Contractor's temporary work not shown on the plans, such as, but not limited to work platforms, temporary construction, pumping operations, plant and storage yards, and cofferdams.
    - (f) Acquire applicable permits and comply with requirements for borrow pits, dewatering, and any temporary work conducted by the Contractor in jurisdictional areas.
    - (g) Conduct all erosion and sediment control/stormwater work in a timely and workmanlike manner.
    - (h) Fully perform and install erosion and sediment control/stormwater work prior to any suspension of the work.
    - (i) Coordinate with Department, Federal, State and Local Regulatory agencies on resolution of erosion and sediment control/stormwater issues due to the Contractor's operations.
    - (j) Ensure that proper cleanup occurs from vehicle tracking on paved surfaces or any location where sediment leaves the Right-of-Way.
    - (k) Have available a set of erosion and sediment control/stormwater plans that are initialed and include the installation date of Best Management Practices. These practices shall include temporary and permanent groundcover and be properly updated to reflect necessary plan and field changes for use and review by Department personnel as well as regulatory agencies.

- (2) Requirements set forth under the NPDES Permit - The Department's NPDES Stormwater permit (NCS000250) outlines certain objectives and management measures pertaining to construction activities. The permit references *NCG010000, General Permit to Discharge Stormwater* under the NPDES, and states that the Department shall incorporate the applicable requirements into its delegated Erosion and Sediment Control Program for construction activities disturbing one or more acres of land. The Department further incorporates these requirements on all contracted bridge and culvert work at jurisdictional waters, regardless of size. Some of the requirements are, but are not limited to:
- (a) Control project site waste to prevent contamination of surface or ground waters of the state, i.e. from equipment operation/maintenance, construction materials, concrete washout, chemicals, litter, fuels, lubricants, coolants, hydraulic fluids, any other petroleum products, and sanitary waste.
  - (b) Inspect erosion and sediment control/stormwater devices and stormwater discharge outfalls at least once every 7 calendar days and within 24 hours after a rainfall event equal to or greater than 1.0 inch that occurs within a 24 hour period. Additional monitoring may be required at the discretion of Division of Water Resources personnel if the receiving stream is 303(d) listed for turbidity and the project has had documented problems managing turbidity.
  - (c) Maintain an onsite rain gauge or use the Department's Multi-Sensor Precipitation Estimate website to maintain a daily record of rainfall amounts and dates.
  - (d) Maintain erosion and sediment control/stormwater inspection records for review by Department and Regulatory personnel upon request.
  - (e) Implement approved reclamation plans on all borrow pits, waste sites and staging areas.
  - (f) Maintain a log of turbidity test results as outlined in the Department's Procedure for Monitoring Borrow Pit Discharge.
  - (g) Provide secondary containment for bulk storage of liquid materials.
  - (h) Provide training for employees concerning general erosion and sediment control/stormwater awareness, the Department's NPDES Stormwater Permit NCS000250 requirements, and the applicable requirements of the *General Permit, NCG010000*.
  - (i) Report violations of the NPDES permit to the Engineer immediately who will notify the Division of Water Quality Regional Office within 24 hours of becoming aware of the violation.
- (3) Quality Control Program - Maintain a quality control program to control erosion, prevent sedimentation and follow provisions/conditions of permits. The quality control program shall:
- (a) Follow permit requirements related to the Contractor and subcontractors' construction activities.

- (b) Ensure that all operators and subcontractors on site have the proper erosion and sediment control/stormwater certification.
  - (c) Notify the Engineer when the required certified erosion and sediment control/stormwater personnel are not available on the job site when needed.
  - (d) Conduct the inspections required by the NPDES permit.
  - (e) Take corrective actions in the proper timeframe as required by the NPDES permit for problem areas identified during the NPDES inspections.
  - (f) Incorporate erosion control into the work in a timely manner and stabilize disturbed areas with mulch/seed or vegetative cover on a section-by-section basis.
  - (g) Use flocculants approved by state regulatory authorities where appropriate and where required for turbidity and sedimentation reduction.
  - (h) Ensure proper installation and maintenance of temporary erosion and sediment control devices.
  - (i) Remove temporary erosion or sediment control devices when they are no longer necessary as agreed upon by the Engineer.
  - (j) The Contractor's quality control and inspection procedures shall be subject to review by the Engineer. Maintain NPDES inspection records and make records available at all times for verification by the Engineer.
- (B) *Certified Foreman* - At least one Certified Foreman shall be onsite for each type of work listed herein during the respective construction activities to control erosion, prevent sedimentation and follow permit provisions:
- (1) Foreman in charge of grading activities
  - (2) Foreman in charge of bridge or culvert construction over jurisdictional areas
  - (3) Foreman in charge of utility activities
- The Contractor may request to use the same person as the Level II Supervisor and Level II Foreman. This person shall be onsite whenever construction activities as described above are taking place. This request shall be approved by the Engineer prior to work beginning.
- The Contractor may request to name a single Level II Foreman to oversee multiple construction activities on small bridge or culvert replacement projects. This request shall be approved by the Engineer prior to work beginning.
- (C) *Certified Installers* - Provide at least one onsite, Level I Certified Installer for each of the following erosion and sediment control/stormwater crew:
- (1) Seeding and Mulching
  - (2) Temporary Seeding
  - (3) Temporary Mulching
  - (4) Sodding
  - (5) Silt fence or other perimeter erosion/sediment control device installations
  - (6) Erosion control blanket installation
  - (7) Hydraulic tackifier installation



- (8) Turbidity curtain installation
- (9) Rock ditch check/sediment dam installation
- (10) Ditch liner/matting installation
- (11) Inlet protection
- (12) Riprap placement
- (13) Stormwater BMP installations (such as but not limited to level spreaders, retention/detention devices)
- (14) Pipe installations within jurisdictional areas

If a Level I *Certified Installer* is not onsite, the Contractor may substitute a Level II Foreman for a Level I Installer, provided the Level II Foreman is not tasked to another crew requiring Level II Foreman oversight.

- (D) *Certified Designer* - Include the certification number of the Level III Certified Designer on the erosion and sediment control/stormwater component of all reclamation plans and if applicable, the certification number of the Level III Certified Designer on the design of the project erosion and sediment control/stormwater plan.

### **Preconstruction Meeting**

Furnish the names of the *Certified Erosion and Sediment Control/Stormwater Supervisor*, *Certified Foremen*, *Certified Installers* and *Certified Designer* and notify the Engineer of changes in certified personnel over the life of the contract within 2 days of change.

### **Ethical Responsibility**

Any company performing work for the North Carolina Department of Transportation has the ethical responsibility to fully disclose any reprimand or dismissal of an employee resulting from improper testing or falsification of records.

### **Revocation or Suspension of Certification**

Upon recommendation of the Chief Engineer to the certification entity, certification for *Supervisor*, *Certified Foremen*, *Certified Installers* and *Certified Designer* may be revoked or suspended with the issuance of an *Immediate Corrective Action (ICA)*, *Notice of Violation (NOV)*, or *Cease and Desist Order* for erosion and sediment control/stormwater related issues.

The Chief Engineer may recommend suspension or permanent revocation of certification due to the following:

- (A) Failure to adequately perform the duties as defined within this certification provision.
- (B) Issuance of an ICA, NOV, or Cease and Desist Order.
- (C) Failure to fully perform environmental commitments as detailed within the permit conditions and specifications.
- (D) Demonstration of erroneous documentation or reporting techniques.
- (E) Cheating or copying another candidate's work on an examination.
- (F) Intentional falsification of records.

- (G) Directing a subordinate under direct or indirect supervision to perform any of the above actions.
- (H) Dismissal from a company for any of the above reasons.
- (I) Suspension or revocation of one's certification by another entity.

Suspension or revocation of a certification will be sent by certified mail to the certificant and the Corporate Head of the company that employs the certificant.

A certificant has the right to appeal any adverse action which results in suspension or permanent revocation of certification by responding, in writing, to the Chief Engineer within 10 calendar days after receiving notice of the proposed adverse action.

Chief Engineer  
1536 Mail Service Center  
Raleigh, NC 27699-1536

Failure to appeal within 10 calendar days will result in the proposed adverse action becoming effective on the date specified on the certified notice. Failure to appeal within the time specified will result in a waiver of all future appeal rights regarding the adverse action taken. The certificant will not be allowed to perform duties associated with the certification during the appeal process.

The Chief Engineer will hear the appeal and make a decision within 7 days of hearing the appeal. Decision of the Chief Engineer will be final and will be made in writing to the certificant.

If a certification is temporarily suspended, the certificant shall pass any applicable written examination and any proficiency examination, at the conclusion of the specified suspension period, prior to having the certification reinstated.

### **Measurement and Payment**

All work described within this provision and the role of Certified Erosion and Sediment Control/Stormwater Supervisor, Certified Foremen, Certified Installers and Certified Designer will be incidental to the project for which no direct compensation will be made.

### **PROCEDURE FOR MONITORING BORROW PIT DISCHARGE:**

(2-20-07) (Rev. 1-16-24)

105-16, 230, 801

SP1 G181

Water discharge from borrow pit sites shall not cause surface waters to exceed 50 NTUs (nephelometric turbidity unit) in streams not designated as trout waters and 10 NTUs in streams, lakes or reservoirs designated as trout waters. For lakes and reservoirs not designated as trout waters, the turbidity shall not exceed 25 NTUs. If the turbidity exceeds these levels due to natural background conditions, the existing turbidity level shall not be increased.

If during any operating day, the downstream water quality exceeds the standard, the Contractor shall do all of the following:

- (A) Either cease discharge or modify the discharge volume or turbidity levels to bring the downstream turbidity levels into compliance, or

- (B) Evaluate the upstream conditions to determine if the exceedance of the standard is due to natural background conditions. If the background turbidity measurements exceed the standard, operation of the pit and discharge can continue as long as the stream turbidity levels are not increased due to the discharge.
- (C) Measure and record the turbidity test results (time, date and sampler) at all defined sampling locations 30 minutes after startup and at a minimum, one additional sampling of all sampling locations during that 24-hour period in which the borrow pit is discharging.
- (D) Notify DWQ within 24 hours of any stream turbidity standard exceedances that are not brought into compliance.

During the Environmental Assessment required by Article 230-4 of the *Standard Specifications*, the Contractor shall define the point at which the discharge enters into the State's surface waters and the appropriate sampling locations. Sampling locations shall include points upstream and downstream from the point at which the discharge enters these waters. Upstream sampling location shall be located so that it is not influenced by backwater conditions and represents natural background conditions. Downstream sampling location shall be located at the point where complete mixing of the discharge and receiving water has occurred.

The discharge shall be closely monitored when water from the dewatering activities is introduced into jurisdictional wetlands. Any time visible sedimentation (deposition of sediment) on the wetland surface is observed, the dewatering activity will be suspended until turbidity levels in the stilling basin can be reduced to a level where sediment deposition does not occur. Staining of wetland surfaces from suspended clay particles, occurring after evaporation or infiltration, does not constitute sedimentation. No activities shall occur in wetlands that adversely affect the functioning of a wetland. Visible sedimentation will be considered an indication of possible adverse impacts on wetland use.

The Engineer will perform independent turbidity tests on a random basis. These results will be maintained in a log within the project records. Records will include, at a minimum, turbidity test results, time, date and name of sampler. Should the Department's test results exceed those of the Contractor's test results, an immediate test shall be performed jointly with the results superseding the previous test results of both the Department and the Contractor.

The Contractor shall use the *NCDOT Turbidity Reduction Options for Borrow Pits Matrix*, available at <https://connect.ncdot.gov/resources/roadside/FieldOperationsDocuments/TurbidityReductionOptionSheet.pdf> to plan, design, construct, and maintain BMPs to address water quality standards. Tier I Methods include stilling basins which are standard compensatory BMPs. Other Tier I methods are noncompensatory and shall be used when needed to meet the stream turbidity standards. Tier II Methods are also noncompensatory and are options that may be needed for protection of rare or unique resources or where special environmental conditions exist at the site which have led to additional requirements being placed in the DWQ's 401 Certifications and approval letters, Isolated Wetland Permits, Riparian Buffer Authorization or a DOT Reclamation Plan's Environmental Assessment for the specific site. Should the Contractor exhaust all Tier I Methods on a site exclusive of rare or unique resources or special

environmental conditions, Tier II Methods may be required by regulators on a case by case basis per supplemental agreement.

The Contractor may use cation exchange capacity (CEC) values from proposed site borings to plan and develop the bid for the project. CEC values exceeding 15 milliequivalents per 100 grams of soil may indicate a high potential for turbidity and should be avoided when dewatering into surface water is proposed.

No additional compensation for monitoring borrow pit discharge will be paid.

**NOTE TO CONTRACTOR:**

1) Payment for removal of existing Bollards will be included in the lump sum payment for Grading.

**PROJECT SPECIAL PROVISIONS****ROADWAY****CLEARING AND GRUBBING - METHOD II:**

(9-17-02)(Rev. 3-19-24)

200

SP2 R02A

Perform clearing on this project to the limits established by Method - II shown on Standard Drawing No. 200.02 of the *Roadway Standard Drawings*. Conventional clearing methods may be used except where permit drawings or conditions have been included in the proposal which require certain areas to be cleared by hand methods.

**BURNING RESTRICTIONS:**

(7-1-95)

200, 210, 215

SP2 R05

Open burning is not permitted on any portion of the right-of-way limits established for this project. Do not burn the clearing, grubbing or demolition debris designated for disposal and generated from the project at locations within the project limits, off the project limits or at any waste or borrow sites in this county. Dispose of the clearing, grubbing and demolition debris by means other than burning, according to state or local rules and regulations.

**BUILDING REMOVAL:**

(1-1-02)(Rev. 1-16-24)

215

SP2 R15 C

Remove the buildings and appurtenances listed below in accordance with Section 215 of the *Standard Specifications*:

<u>Parcel #</u>	<u>Item Removal</u>	<u>Location</u>
014	Wooden Storage Building	SS 45+90.00, RT of SL -L-
023	1SBKD	SS 41+00.00, LT of SL -L-
064	Greenhouse, Barn	SS 80+00.00, RT of SL -L-
081	1SBKD	SS 94+00.00, LT of SL -L-

When the description of the work for an item indicates a building partially inside and partially outside the right of way and/or construction area, but does not require the building to be cut off, the entire building shall be removed.

**TEMPORARY PAVEMENT:**

(8-15-00) (Rev. 4-21-15)

1101

SP2 R30A(Rev)

Construct the temporary pavement required on this project in accordance with the plans or as directed by the Engineer.

After the temporary pavement has served its purpose, remove the portions deemed unsuitable for use as a permanent part of the project as directed by the Engineer. Salvage and stockpile the aggregate base course removed from the temporary pavement at locations within the right of way, as directed by the Engineer, for removal by State Forces. Place pavement and earth material removed from the temporary pavement locations in embankments or dispose of in waste areas furnished by the Contractor.

Pipe culverts removed from the temporary pavement locations remain the property of the Contractor. Pipe culverts that are removed will be measured and will be paid at the contract unit price per linear foot for *Pipe Removal*. Payment for the construction of the temporary pavement will be made at the contract unit prices for the various items involved.

No direct payment will be made for removing the aggregate base course, earth material and pavement, as the cost of same shall be included in the lump sum price bid for *Grading*. Such prices and payments will be full compensation for the work of removing, salvaging, and stockpiling aggregate base course; and for placing earth material and pavement in embankments or disposing of earth material and pavement in waste areas.

#### **SHOULDER AND FILL SLOPE MATERIAL:**

(5-21-02)(Rev. 1-16-24)

235, 560

SP2 R45 A

#### **Description**

Perform the required shoulder and slope construction for this project in accordance with the applicable requirements of Section 560 and Section 235 of the *Standard Specifications*.

#### **Measurement and Payment**

Where the material has been obtained from an authorized stockpile or from a borrow source and *Borrow Excavation* is not included in the contract, no direct payment will be made for this work, as the cost of this work will be part of the work being paid at the contract lump sum price for *Grading*. If *Borrow Excavation* is included in this contract and the material has been obtained from an authorized stockpile or from a borrow source, measurement and payment will be as provided in Section 230 of the *Standard Specifications* for *Borrow Excavation*.

#### **MANUFACTURED QUARRY FINES IN EMBANKMENTS:**

(01-17-17)(Rev. 4-16-24)

235

SP02 R72

#### **Description**

This specification addresses the use of manufactured quarry fines that are not classified as select materials. The specification allows the Contractor an option, with the approval of the Engineer, to use manufactured quarry fines (MQFs) in embankments as a substitute for conventional borrow material. Furnish and place geotextile for subgrade stabilization in accordance with the contract. Geotextile for subgrade stabilization is required to prevent pavement cracking and provide separation between the subgrade and pavement section at embankment locations where manufactured quarry fines are utilized and as directed by the Engineer.

**Materials**

Manufactured Quarry Fines.

Site specific approval of MQFs material will be required prior to beginning construction as detailed in the preconstruction requirements of this provision.

The following MQFs are unacceptable:

- (A) Frozen material,
- (B) Material with a maximum dry unit weight of less than 90 pounds per cubic foot when tested in accordance with AASHTO T 99 Method A or C.
- (C) Material with greater than 80% by weight Passing the #200 sieve

Collect and transport MQFs in a manner that will prevent nuisances and hazards to public health and safety. Moisture condition the MQFs as needed and transport in covered trucks to prevent dusting. If MQFs are blended with natural earth material, follow Borrow Criteria in Section 1018 of the *Standard Specifications*.

**Preconstruction Requirements**

When MQFs are to be used as a substitute for earth borrow material, request written approval from the Engineer at least ninety (90) days in advance of the intent to use MQFs and include the following details:

- (A) Description, purpose and location of project.
- (B) Estimated start and completion dates of project.
- (C) Estimated volume of MQFs to be used on project with specific locations and construction details of the placement.
- (D) The names, address, and contact information for the generator of the MQFs.
- (E) Physical location of the site at which the MQFs were generated.

The Engineer will forward this information to the State Materials Engineer for review and material approval.

**Construction Methods**

Place MQFs in the core of the embankment section with at least 4 feet of earth cover to the outside limits of the embankments or subgrade.

Construct embankments by placing MQFs in level uniform lifts with no more than a lift of 10 inches and compacted to at least a density of 95 percent as determined by test methods in AASHTO T 99, Determination of Maximum Dry Density and Optimum Moisture Content, Method A or C depending upon particle size of the product. Provide a moisture content at the time of compaction of within 4 percent of optimum but not greater than one percent above optimum as determined by AASHTO T 99, Method A or C.

In embankments where MQFs are incorporated, geotextile for subgrade stabilization shall be used. Refer to Article 505-2 of the *Standard Specifications* for geotextile type and Article 505-3

of the *Standard Specifications* for the geotextile construction methods.

### **Measurement and Payment**

*Borrow Excavation* will be measured by truck volume and paid in cubic yards in accordance with Article 230-5 of the *Standard Specifications*. As an alternate weigh tickets can be provided and payment made by converting weight to cubic yards based on the verifiable unit weight. Where the pay item for *Borrow Excavation* is not included in the original contract then no separate payment will be made for this item and payment will be included in the lump sum price bid for *Grading*.

*Geotextile for Subgrade Stabilization* will be measured and paid in accordance with Article 505-4 of the *Standard Specifications*. When the pay item for *Geotextile for Subgrade Stabilization* is not included in the original contract then no payment will be made for this item and will be considered incidental to the use of MQFs in embankment.

### **CORRUGATED ALUMINUM ALLOY CULVERT PIPE:**

(9-21-21)(Rev. 1-16-24)

305, 310

SP3 R34

Revise the *Standard Specifications* as follows:

**Page 3-5, Article 305-2, MATERIALS**, add the following after line 16:

<b>Item</b>	<b>Section</b>
Waterborne Paint	1080-9
Hot Bitumen	1081-3

**Page 3-5, Article 305-3, CONSTRUCTION METHODS**, add the following after line 26:

Coating must be applied to the aluminum when in contact with concrete. Immediately prior to coating, aluminum surfaces to be coated shall be cleaned by a method that will remove all dirt, oil, grease, chips, and other foreign substances. Aluminum to be coated shall be given one coat of suitable quality coating such as:

Approved waterborne paint (Section 1080-9)

Approved Hot Bitumen (Section 1081-3)

Other coating materials may be submitted to the Engineer for approval.

**Page 3-7, Article 310-6, MEASUREMENT AND PAYMENT, lines 10-11**, delete the fourth sentence and replace with the following:

Select bedding and backfill material and coating will be included in the cost of the installed pipe.



**PRICE ADJUSTMENT - ASPHALT BINDER FOR PLANT MIX:**

(11-21-00)(Rev. 1-16-24)

620

SP6 R25

Price adjustments for asphalt binder for plant mix will be made in accordance with Section 620 of the *Standard Specifications*.

The base price index for asphalt binder for plant mix is \$ **573.50** per ton.

This base price index represents an average of F.O.B. selling prices of asphalt binder at supplier's terminals on **November 1, 2024**.

**FINAL SURFACE TESTING NOT REQUIRED:**

(5-18-04) (Rev. 2-16-16)

610

SP6 R45

Final surface testing is not required on this project in accordance with Section 610-13, *Final Surface Testing and Acceptance*.

**FOUNDATIONS AND ANCHOR ROD ASSEMBLIES FOR METAL POLES:**

(1-17-12)(Rev. 1-16-24)

9, 14, 17

SP9 R05

**Description**

Foundations for metal poles include foundations for signals, cameras, overhead and dynamic message signs (DMS) and high mount and light standards supported by metal poles or upright trusses. Foundations consist of footings with pedestals and drilled piers with or without grade beams or wings. Anchor rod assemblies consist of anchor rods (also called anchor bolts) with nuts and washers on the exposed ends of rods and nuts and a plate or washers on the other ends of rods embedded in the foundation.

Construct concrete foundations with the required resistances and dimensions and install anchor rod assemblies in accordance with the contract and accepted submittals. Construct drilled piers consisting of cast-in-place reinforced concrete cylindrical sections in excavated holes. Provide temporary casings or polymer slurry as needed to stabilize drilled pier excavations. Use a prequalified Drilled Pier Contractor to construct drilled piers for metal poles. Define "excavation" and "hole" as a drilled pier excavation and "pier" as a drilled pier.

This provision does not apply to foundations for signal pedestals; see Section 1743 of the *Standard Specifications* and Roadway Standard Drawing No. 1743.01.

**Materials**

Refer to the *Standard Specifications*.

<b>Item</b>	<b>Section</b>
Conduit	1091-3
Grout, Type 2	1003
Polymer Slurry	411-2(B)(2)
Portland Cement Concrete	1000
Reinforcing Steel	1070
Rollers and Chairs	411-2(C)
Temporary Casings	411-2(A)

Provide Type 3 material certifications in accordance with Article 106-3 of the *Standard Specifications* for conduit, rollers, chairs and anchor rod assemblies. Store steel materials on blocking at least 12" above the ground and protect it at all times from damage; and when placing in the work make sure it is free from dirt, dust, loose mill scale, loose rust, paint, oil or other foreign materials. Load, transport, unload and store foundation and anchor rod assembly materials so materials are kept clean and free of damage. Bent, damaged or defective materials will be rejected.

Use conduit type in accordance with the contract. Use Class A concrete for footings and pedestals, Class Drilled Pier concrete for drilled piers and Class AA concrete for grade beams and wings including portions of drilled piers above bottom of wings elevations. Corrugated temporary casings may be accepted at the discretion of the Engineer. A list of approved polymer slurry products is available from:

[connect.ncdot.gov/resources/Geological/Pages/Products.aspx](http://connect.ncdot.gov/resources/Geological/Pages/Products.aspx)

Provide anchor rod assemblies in accordance with the contract consisting of the following:

- (A) Straight anchor rods,
- (B) Heavy hex top and leveling nuts and flat washers on exposed ends of rods, and
- (C) Nuts and either flat plates or washers on the other ends of anchor rods embedded in foundations.

Do not use lock washers. Use steel anchor rods, nuts and washers that meet ASTM F1554 for Grade 55 rods and Grade A nuts. Use steel plates and washers embedded in concrete with a thickness of at least 1/4". Galvanize anchor rods and exposed nuts and washers in accordance with Article 1076-4 of the *Standard Specifications*. It is not necessary to galvanize nuts, plates and washers embedded in concrete.

## Construction Methods

Install the required size and number of conduits in foundations in accordance with the plans and accepted submittals. Construct top of piers, footings, pedestals, grade beams and wings flat, level and within 1" of elevations shown in the plans or approved by the Engineer. Provide an Ordinary Surface finish in accordance with Subarticle 825-6(B) of the *Standard Specifications* for portions of foundations exposed above finished grade. Do not remove anchor bolt templates or pedestal or grade beam forms or erect metal poles or upright trusses onto foundations until concrete attains a compressive strength of at least 3,000 psi.

### (A) Drilled Piers

Before starting drilled pier construction, hold a predrill meeting to discuss the installation, monitoring and inspection of the drilled piers. Schedule this meeting after the Drilled Pier Contractor has mobilized to the site. The Resident or Division Traffic Engineer, Contractor and Drilled Pier Contractor Superintendent will attend this predrill meeting.

Do not excavate holes, install piles or allow equipment wheel loads or vibrations within 20 ft of completed piers until 16 hours after Drilled Pier concrete reaches initial set.

Check for correct drilled pier alignment and location before beginning drilling. Check plumbness of holes frequently during drilling.

Construct drilled piers with the minimum required diameters shown in the plans. Install piers with tip elevations no higher than shown in the plans or approved by the Engineer.

Excavate holes with equipment of the sizes required to construct drilled piers. Depending on the subsurface conditions encountered, drilling through rock and boulders may be required. Do not use blasting for drilled pier excavations.

Contain and dispose of drilling spoils and waste concrete as directed and in accordance with Section 802 of the *Standard Specifications*. Drilling spoils consist of all materials and fluids removed from excavations.

If unstable, caving or sloughing materials are anticipated or encountered, stabilize holes with temporary casings and/or polymer slurry. Do not use telescoping temporary casings. If it becomes necessary to replace a temporary casing during drilling, backfill the excavation, insert a larger casing around the casing to be replaced or stabilize the excavation with polymer slurry before removing the temporary casing.

If temporary casings become stuck or the Contractor proposes leaving casings in place, temporary casings should be installed against undisturbed material. Unless otherwise approved, do not leave temporary casings in place for mast arm poles and cantilever signs. The Engineer will determine if casings may remain in place. If the Contractor proposes leaving temporary casings in place, do not begin drilling until a casing installation method is approved.

Use polymer slurry and additives to stabilize holes in accordance with the slurry manufacturer's recommendations. Provide mixing water and equipment suitable for polymer slurry. Maintain the required slurry properties at all times except for sand content.

Define a "sample set" as slurry samples collected from mid-height and within 2 ft of the bottom of holes. Take sample sets from excavations to test polymer slurry immediately after filling holes with slurry, at least every 4 hours thereafter and immediately before placing concrete. Do not place Drilled Pier concrete until both slurry samples from an excavation meet the required polymer slurry properties. If any slurry test results do not meet the requirements, the Engineer may suspend drilling until both samples from a sample set meet the required polymer slurry properties.

Remove soft and loose material from bottom of holes using augers to the satisfaction of the Engineer. Assemble rebar cages and place cages and Drilled Pier concrete in accordance with Subarticle 411-4(E) of the *Standard Specifications* except for the following:

- (1) Inspections for tip resistance and bottom cleanliness are not required,
- (2) Temporary casings may remain in place if approved, and
- (3) Concrete placement may be paused near the top of pier elevations for anchor rod assembly installation and conduit placement or
- (4) If applicable, concrete placement may be stopped at bottom of grade beam or wings elevations for grade beam or wing construction.

If wet placement of concrete is anticipated or encountered, do not place Drilled Pier concrete until a concrete placement procedure is approved. If applicable, temporary casings and fluids may be removed when concrete placement is paused or stopped in accordance with the exceptions above provided holes are stable. Remove contaminated concrete from exposed Drilled Pier concrete after removing casings and fluids. If holes are unstable, do not remove temporary casings until a procedure for placing anchor rod assemblies and conduit or constructing grade beams or wings is approved.

Use collars to extend drilled piers above finished grade. Remove collars after Drilled Pier concrete sets and round top edges of piers.

If drilled piers are questionable, pile integrity testing (PIT) and further investigation may be required in accordance with Article 411-5 of the *Standard Specifications*. A drilled pier will be considered defective in accordance with Subarticle 411-5(D) of the *Standard Specifications* and drilled pier acceptance is based in part on the criteria in Article 411-6 of the *Standard Specifications* except for the top of pier tolerances in Subarticle 411-6(C) of the *Standard Specifications*.

If a drilled pier is under further investigation, do not grout core holes, backfill around the pier or perform any work on the drilled pier until the Engineer accepts the pier. If the drilled pier is accepted, dewater and grout core holes and backfill around the pier with approved material to finished grade. If the Engineer determines a pier is unacceptable,

remediation is required in accordance with Article 411-6 of the *Standard Specifications*. No extension of completion date or time will be allowed for remediation of unacceptable drilled piers or post repair testing.

Permanently embed a plate in or mark top of piers with the pier diameter and depth, size and number of vertical reinforcing bars and the minimum compressive strength of the concrete mix at 28 days.

(B) Footings, Pedestals, Grade Beams and Wings

Excavate as necessary for footings, grade beams and wings in accordance with the plans, accepted submittals and Section 410 of the *Standard Specifications*. If unstable, caving or sloughing materials are anticipated or encountered, shore foundation excavations as needed with an approved method. Notify the Engineer when foundation excavation is complete. Do not place concrete or reinforcing steel until excavation dimensions and foundation material are approved.

Construct cast-in-place reinforced concrete footings, pedestals, grade beams and wings with the dimensions shown in the plans and in accordance with Section 825 of the *Standard Specifications*. Use forms to construct portions of pedestals and grade beams protruding above finished grade. Provide a chamfer with a 3/4" horizontal width for pedestal and grade beam edges exposed above finished grade. Place concrete against undisturbed soil or backfill and fill in accordance with Article 410-8 of the *Standard Specifications*. Proper compaction around footings and wings is critical for foundations to resist uplift and torsion forces.

(C) Anchor Rod Assemblies

Size anchor rods for design and the required projection above top of foundations. Determine required anchor rod projections from nut, washer and base plate thicknesses, the protrusion of 3 to 5 anchor rod threads above top nuts after tightening and the distance of one nut thickness between top of foundations and bottom of leveling nuts.

Protect anchor rod threads from damage during storage and installation of anchor rod assemblies. Before placing anchor rods in foundations, turn nuts onto and off rods past leveling nut locations. Turn nuts with the effort of one workman using an ordinary wrench without a cheater bar. Report any thread damage to the Engineer that requires extra effort to turn nuts.

Arrange anchor rods symmetrically about center of base plate locations as shown in the plans. Set anchor rod elevations based on required projections above top of foundations. Securely brace and hold rods in the correct position, orientation and alignment with a steel template. Do not weld to reinforcing steel, temporary casings or anchor rods.

Install top and leveling (bottom) nuts, washers and the base plate for each anchor rod assembly in accordance with the following procedure:

- (1) Turn leveling nuts onto anchor rods to a distance of one nut thickness between the top of foundation and bottom of leveling nuts. Place washers over anchor rods on top of leveling nuts.
- (2) Determine if nuts are level using a flat rigid template on top of washers. If necessary, lower leveling nuts to level the template in all directions or if applicable, lower nuts to tilt the template so the metal pole or upright truss will lean as shown in the plans. If leveling nuts and washers are not in full contact with the template, replace washers with galvanized beveled washers.
- (3) Verify the distance between the foundation and leveling nuts is no more than one nut thickness.
- (4) Place base plate with metal pole or upright truss over anchor rods on top of washers. High mount luminaires may be attached before erecting metal poles but do not attach cables, mast arms or trusses to metal poles or upright trusses at this time.
- (5) Place washers over anchor rods on top of base plate. Lubricate top nut bearing surfaces and exposed anchor rod threads above washers with beeswax, paraffin or other approved lubricant.
- (6) Turn top nuts onto anchor rods. If nuts are not in full contact with washers or washers are not in full contact with the base plate, replace washers with galvanized beveled washers.
- (7) Tighten top nuts to snug-tight with the full effort of one workman using a 12" wrench. Do not tighten any nut all at once. Turn top nuts in increments. Follow a star pattern cycling through each nut at least twice.
- (8) Repeat (7) for leveling nuts.
- (9) Replace washers above and below the base plate with galvanized beveled washers if the slope of any base plate face exceeds 1:20 (5%), any washer is not in firm contact with the base plate or any nut is not in firm contact with a washer. If any washers are replaced, repeat (7) and (8).
- (10) With top and leveling nuts snug-tight, mark each top nut on a corner at the intersection of 2 flats and a corresponding reference mark on the base plate. Mark top nuts and base plate with ink or paint that is not water-soluble. Use the turn-of-nut method for pretensioning. Do not pretension any nut all at once. Turn top nuts in increments for a total turn that meets the following nut rotation requirements:

<b>NUT ROTATION REQUIREMENTS (Turn-of-Nut Pretensioning Method)</b>	
<b>Anchor Rod Diameter, inch</b>	<b>Requirement</b>
$\leq 1 \frac{1}{2}$	1/3 turn (2 flats)
$> 1 \frac{1}{2}$	1/6 turn (1 flat)

Follow a star pattern cycling through each top nut at least twice.

- (11) Ensure nuts, washers and base plate are in firm contact with each other for each anchor rod. Cables, mast arms and trusses may now be attached to metal poles and upright trusses.
- (12) Between 4 and 14 days after pretensioning top nuts, use a torque wrench

calibrated within the last 12 months to check nuts in the presence of the Engineer. Completely erect mast arm poles and cantilever signs and attach any hardware before checking top nuts for these structures. Check that top nuts meet the following torque requirements:

<b>TORQUE REQUIREMENTS</b>	
<b>Anchor Rod Diameter, inch</b>	<b>Requirement, ft-lb</b>
7/8	180
1	270
1 1/8	380
1 1/4	420
≥ 1 1/2	600

If necessary, retighten top nuts in the presence of the Engineer with a calibrated torque wrench to within  $\pm 10$  ft-lb of the required torque. Do not overtighten top nuts.

- (13) Do not grout under base plate.

### **Measurement and Payment**

Foundations and anchor rod assemblies for metal poles and upright trusses will be measured and paid for elsewhere in the contract.

No payment will be made for temporary casings that remain in drilled pier excavations. No payment will be made for PIT. No payment will be made for further investigation of defective piers. Further investigation of piers that are not defective will be paid as extra work in accordance with Article 104-7 of the *Standard Specifications*. No payment will be made for remediation of unacceptable drilled piers or post repair testing.

### **HIGH STRENGTH CONCRETE FOR DRIVEWAYS:**

(11-21-00)(Rev. 1-16-24)

848

SP10 R02

Use high early strength concrete for all driveways shown in the plans and as directed by the Engineer. Provide high early strength concrete that meets the requirements of Article 1000-6 of the *Standard Specifications*.

Measurement and payment will be in accordance with Section 848 of the *Standard Specifications*.

### **ELECTRONIC TICKETING SYSTEM:**

(7-16-24)(Rev. 12-17-24)

1020

SP10 R20

### **Description**

At the contractor's option, the use of an electronic ticketing system for reporting individual and cumulative asphalt material deliveries may be utilized on this project. At the preconstruction conference, the contractor shall notify the Engineer if they intend to utilize an electronic ticketing system for reporting individual and cumulative asphalt material deliveries to the project.

**Electronic Ticketing Requirements**

- a. The electronic ticketing system must be fully integrated with the load read-out system at the plant. The system shall be designed so data inputs from scales cannot be altered by either the Contractor or the Department.
- b. Material supplier must test to confirm that ticketing data can be shared from the originating system no less than 30 days prior to project start.
- c. After each truck is loaded, ticket data must be electronically captured, and ticket information uploaded via Application Programming Interface (API) to the Department.
- d. Obtain security token from NCDOT for access to E-Ticketing portal (to send tickets). To request a Security Key, fill out the below E-Ticketing Security Request Form: <https://forms.office.com/g/XnT7QeRtgt>
- e. Obtain API from NCDOT containing the required e-ticketing data fields and format. Download the API from the NCDOT E-ticketing Webpage: <https://connect.ncdot.gov/projects/construction/E-Ticketing/Pages/default.aspx>
- f. Provide all ticket information in real time and daily summaries to the Department's designated web portal. If the project contains locations with limited cellular service, an alternative course of action must be agreed upon.
- g. Electronic ticketing submissions must be sent between the Material Supplier and the Department.
- h. The electronic ticket shall contain the following information:

Date  
Contract Number  
Supplier Name  
Contractor Name  
Material  
JMF  
Gross Weight  
Tare Weight  
Net Weight  
Load Number  
Cumulative Weight  
Truck Number  
Weighmaster Certification  
Weighmaster Expiration  
Weighmaster Name  
Facility Name  
Plant Certification Number  
Ticket Number



Hauling Firm (optional)  
 Voided Ticket Number (if necessary)  
 Original Ticket Number (if necessary)  
 Supplier Revision (If necessary)

The Contractor/supplier can use the electronic ticketing system of their choice to meet the requirements of this provision.

### Measurement and Payment

No measurement or payment will be made for utilizing an electronic ticketing system as the cost of such shall be included in the contract price bid for the material being provided.

### **GLASS BEAD GRADATION FOR PAVEMENT MARKINGS:**

(9-17-24)

1087

SP10 R87

Revise the *Standard Specifications* as follows:

**Page 10-187, Subarticle 1087-4(C), Gradation & Roundness, after line 6, delete and replace Table 1087-2 with the following:**

<b>TABLE 1087-2</b>		
<b>GLASS BEAD GRADATION REQUIREMENTS</b>		
<b>Sieve Size</b>	<b>Gradation Requirements</b>	
	<b>Minimum</b>	<b>Maximum</b>
Passing #20	100%	--
Retained on #30	5%	15%
Retained on #50	40%	80%
Retained on #80	15%	40%
Passing #80	0%	10%
Retained on #200	0%	5%

### **TEMPORARY SHORING:**

(2-20-07)(Rev. 1-16-24)

SP11 R02

### Description

Temporary shoring includes cantilever, braced and anchored shoring and temporary mechanically stabilized earth (MSE) walls. Temporary shoring does not include trench boxes. At the Contractor's option, use any type of temporary shoring unless noted otherwise in the plans or as directed. Design and construct temporary shoring based on actual elevations and shoring dimensions in accordance with the contract and accepted submittals. Construct temporary shoring at locations shown in the plans and as directed. Temporary shoring is required to maintain traffic when a 2:1 (H:V) slope from the top of an embankment or bottom of an excavation will intersect the existing ground line less than 5 feet from the edge of pavement of an open travelway. This provision does not apply to pipe, inlet or utility installation unless noted otherwise in the plans.

Positive protection includes concrete barrier and temporary guardrail. Provide positive protection for temporary shoring at locations shown in the plans and as directed. Positive

protection is required if temporary shoring is located in the clear zone in accordance with the *AASHTO Roadside Design Guide*.

(A) Cantilever and Braced Shoring

Cantilever shoring consists of steel sheet piles or H-piles with timber lagging. Braced shoring consists of sheet piles or H-piles with timber lagging and bracing such as beams, plates, walers, struts, rakers, etc. Define “piles” as sheet piles or H-piles.

(B) Anchored Shoring

Anchored shoring consists of sheet piles with walers or H-piles with timber lagging anchored with ground or helical anchors. Driven anchors may be accepted at the discretion of the Engineer. A ground anchor consists of a grouted steel bar or multi-strand tendon with an anchorage. A helical anchor consists of a lead section with a central steel shaft and at least one helix steel plate followed by extensions with only central shafts (no helixes) and an anchorage. Anchorages consist of steel bearing plates with washers and hex nuts for bars or steel wedge plates and wedges for strands. Use a prequalified Anchored Wall Contractor to install ground anchors. Define “anchors” as ground, helical or driven anchors.

(C) Temporary MSE Walls

Temporary MSE walls include temporary geosynthetic and wire walls. Define “temporary wall” as a temporary MSE wall and “Temporary Wall Vendor” as the vendor supplying the temporary MSE wall. Define “reinforcement” as geotextile, geogrid, geostrip, welded wire grid or metallic strip reinforcement.

Temporary geosynthetic walls consist of geotextiles or geogrids wrapped behind welded wire facing or geostrips connected to welded wire facing. Define “temporary geotextile wall” as a temporary geosynthetic wall with geotextile reinforcement, “temporary geogrid wall” as a temporary geosynthetic wall with geogrid reinforcement and “temporary geostrip wall” as a temporary geosynthetic wall with geostrip reinforcement.

Temporary wire walls consist of welded wire grid or metallic strip reinforcement connected to welded wire facing. Define “Wire Wall Vendor” as the vendor supplying the temporary wire wall.

(D) Embedment

Define “embedment” for cantilever, braced and anchored shoring as the pile depth below the grade in front of shoring. Define “embedment” for temporary walls as the wall embedment below the grade at the wall face.

(E) Positive Protection

Define “unanchored or anchored portable concrete barrier” as portable concrete barrier (PCB) that meets *Roadway Standard Drawing* No. 1170.01. Define “concrete barrier” as

unanchored or anchored PCB or an approved equal. Define “temporary guardrail” as temporary steel beam guardrail that meets *Roadway Standard Drawing* No. 862.02.

## Materials

Refer to the *Standard Specifications*.

Item	Section
Concrete Barrier Materials	1170-2
Flowable Fill, Excavatable	1000-7
Geosynthetics	1056
Grout, Type 1	1003
Portland Cement	1024-1
Portland Cement Concrete	1000
Select Materials	1016
Steel Beam Guardrail Materials	862-2
Steel Plates	1072-2
Steel Sheet Piles and H-Piles	1084
Untreated Timber	1082-2
Water	1024-4
Welded Wire Reinforcement	1070-3

Provide Type 6 material certifications for shoring materials in accordance with Article 106-3 of the *Standard Specifications*. Use Class IV select material for temporary guardrail and Class A concrete that meets Article 450-2 of the *Standard Specifications* or Type 1 grout for drilled-in piles. Provide untreated timber with a thickness of at least 3 inches and a bending stress of at least 1,000 pounds per square inch for timber lagging. Provide steel bracing that meets ASTM A36.

### (A) Shoring Backfill

Use Class II, Type 1, Class III, Class V or Class VI select material or material that meets AASHTO M 145 for soil classification A-2-4 with a maximum PI of 6 for shoring backfill except do not use A-2-4 soil for backfill around culverts.

### (B) Anchors

Store anchor materials on blocking a minimum of 12 inches above the ground and protect it at all times from damage; and when placing in the work make sure it is free from dirt, dust, loose mill scale, loose rust, paint, oil or other foreign materials. Load, transport, unload and store anchor materials so materials are kept clean and free of damage. Bent, damaged or defective materials will be rejected.

#### (1) Ground Anchors

Use high-strength deformed steel bars that meet AASHTO M 275 or seven-wire strands that meet ASTM A886 or Article 1070-5 of the *Standard Specifications*. Splice bars in accordance with Article 1070-9 of the *Standard Specifications*.

Do not splice strands. Use bondbreakers, spacers and centralizers that meet Article 6.3.5 of the *AASHTO LRFD Bridge Construction Specifications*.

Use neat cement grout that only contains cement and water with a water cement ratio of 0.4 to 0.5 which is approximately 5.5 gallons of water per 94 pounds of Portland cement. Provide grout with a compressive strength at 3 and 28 days of at least 1,500 and 4,000 psi, respectively.

(2) Helical Anchors

Use helical anchors with an ICC Evaluation Service, Inc. (ICC-ES) report. Provide couplers, thread bar adapters and bolts recommended by the Anchor Manufacturer to connect helical anchors together and to piles.

(3) Anchorages

Provide steel plates for bearing plates and steel washers, hex nuts, wedge plates and wedges recommended by the Anchor Manufacturer.

(C) Temporary Walls

(1) Welded Wire Facing

Use welded wire reinforcement for welded wire facing, struts and wires. For temporary wire walls, provide welded wire facing supplied by the Wire Wall Vendor or a manufacturer approved or licensed by the vendor. For temporary wire walls with separate reinforcement and facing components, provide connectors (e.g., bars, clamps, plates, etc.) and fasteners (e.g., bolts, nuts, washers, etc.) required by the Wire Wall Vendor.

(2) Geotextiles

Provide Type 2 geotextile for separation and retention geotextiles. Provide Type 5 geotextile for geotextile reinforcement with ultimate tensile strengths in accordance with the accepted submittals.

(3) Geogrid and Geostrip Reinforcement

Use geogrids with a roll width of at least 4 feet. Use geogrids for geogrid reinforcement and geostrips for geostrip reinforcement with an “approved” status code in accordance with the NCDOT Geosynthetic Reinforcement Evaluation Program. The list of approved geogrids and geostrips is available from: [connect.ncdot.gov/resources/Geological/Pages/Products.aspx](http://connect.ncdot.gov/resources/Geological/Pages/Products.aspx)

Provide geogrids and geostrips with design strengths in accordance with the accepted submittals. Geogrids and geostrips are approved for short-term design strengths (3-year design life) in the machine direction (MD) and cross-machine direction (CD) based on material type. Define material type from the website

above for shoring backfill as follows:

<b>Material Type</b>	<b>Shoring Backfill</b>
Borrow	A-2-4 Soil
Fine Aggregate	Class II, Type 1 or Class III Select Material
Coarse Aggregate	Class V or VI Select Material

(4) Welded Wire Grid and Metallic Strip Reinforcement

Provide welded wire grid and metallic strip reinforcement supplied by the Wire Wall Vendor or a manufacturer approved or licensed by the vendor. Use welded wire grid reinforcement (“mesh”, “mats” and “ladders”) that meet Article 1070-3 of the *Standard Specifications* and metallic strip reinforcement (“straps”) that meet ASTM A572 or A1011.

### **Preconstruction Requirements**

(A) Concrete Barrier

Define “clear distance” behind concrete barrier as the horizontal distance between the barrier and edge of pavement. The minimum required clear distance for concrete barrier is shown in the plans. At the Contractor’s option or if the minimum required clear distance is not available, set concrete barrier next to and up against traffic side of temporary shoring except for barrier above temporary walls. Concrete barrier with the minimum required clear distance is required above temporary walls.

(B) Temporary Guardrail

Define “clear distance” behind temporary guardrail as the horizontal distance between guardrail posts and temporary shoring. At the Contractor’s option or if clear distance for cantilever, braced and anchored shoring is less than 4 feet, attach guardrail to traffic side of shoring as shown in the plans. Place ABC in clear distance and around guardrail posts instead of pavement. Do not use temporary guardrail above temporary walls.

(C) Temporary Shoring Designs

Before beginning temporary shoring design, survey existing ground elevations in the vicinity of shoring locations to determine actual design heights (H). Submit PDF files of working drawings and design calculations for temporary shoring designs in accordance with Article 105-2 of the *Standard Specifications*. Submit working drawings showing plan views, shoring profiles, typical sections and details of temporary shoring design and construction sequence. Do not begin shoring construction until a design submittal is accepted.

Have cantilever and braced shoring designed, detailed and sealed by an engineer licensed in the state of North Carolina. Use a prequalified Anchored Wall Design Consultant to design anchored shoring. Provide anchored shoring designs sealed by a Design Engineer approved as a Geotechnical Engineer (key person) for an Anchored Wall Design

Consultant. Include details in anchored shoring working drawings of anchor locations and lock-off loads, unit grout/ground bond strengths for ground anchors or minimum installation torque and torsional strength rating for helical anchors and if necessary, obstructions extending through shoring or interfering with anchors. Include details in the anchored shoring construction sequence of pile and anchor installation, excavation and anchor testing.

Provide temporary wall designs sealed by a Design Engineer licensed in the state of North Carolina and employed or contracted by the Temporary Wall Vendor. Include details in temporary wall working drawings of geotextile and reinforcement types, locations and directions and obstructions extending through walls or interfering with reinforcement.

(1) Soil Parameters

Design temporary shoring for the assumed soil parameters and groundwater or flood elevations shown in the plans. Assume the following soil parameters for shoring backfill:

(a) Unit weight ( $\gamma$ ) = 120 pcf,

(b)	Friction Angle ( $\phi$ )	Shoring Backfill
	30°	A-2-4 Soil
	34°	Class II, Type 1 or Class III Select Material
	38°	Class V or VI Select Material

(c) Cohesion ( $c$ ) = 0 psf.

(2) Traffic Surcharge

Design temporary shoring for a traffic surcharge of 250 pounds per square foot if traffic will be above and within H of shoring. This traffic surcharge does not apply to construction traffic. Design temporary shoring for any construction surcharge if construction traffic will be above and within H of shoring. Design temporary shoring for a traffic (live load) surcharge in accordance with Article 11.5.6 of the *AASHTO LRFD Bridge Design Specifications*.

(3) Cantilever, Braced and Anchored Shoring Designs

Use shoring backfill for fill sections and voids between cantilever, braced and anchored shoring and the critical failure surface. Use concrete or Type 1 grout for embedded portions of drilled-in H-piles. Do not use drilled-in sheet piles.

Define “top of shoring” for cantilever, braced and anchored shoring as where the grade intersects the back of sheet piles or H-piles and timber lagging. Design cantilever, braced and anchored shoring for a traffic impact load of 2,000 pounds per foot applied 18 inches above top of shoring if concrete barrier is above and next to shoring or temporary guardrail is above and attached to shoring. Extend

cantilever, braced and anchored shoring at least 32 inches above top of shoring if shoring is designed for traffic impact. Otherwise, extend shoring at least 6 inches above top of shoring.

Design cantilever, braced and anchored shoring for a maximum deflection of 3 inches if the horizontal distance to the closest edge of pavement or structure is less than H. Otherwise, design shoring for a maximum deflection of 6 inches. Design cantilever and braced shoring in accordance with the plans and *AASHTO Guide Design Specifications for Bridge Temporary Works*.

Design anchored shoring in accordance with the plans and Article 11.9 of the *AASHTO LRFD Bridge Design Specifications*. Use a resistance factor of 0.80 for tensile resistance of anchors with bars, strands or shafts. Extend the unbonded length for ground anchors and the shallowest helix for helical anchors at least 5 feet behind the critical failure surface. Do not extend anchors beyond right-of-way or easement limits. If existing or future obstructions such as foundations, guardrail posts, pavements, pipes, inlets or utilities will interfere with anchors, maintain a clearance of at least 6 inches between obstructions and anchors.

(4) Temporary Wall Designs

Use shoring backfill in the reinforced zone of temporary walls. Separation geotextiles are required between shoring backfill and backfill, natural ground or culverts along the sides of the reinforced zone perpendicular to the wall face. For Class V or VI select material in the reinforced zone, separation geotextiles are also required between shoring backfill and backfill or natural ground on top of and at the back of the reinforced zone.

Design temporary walls in accordance with the plans and Article 11.10 of the *AASHTO LRFD Bridge Design Specifications*. Embed temporary walls at least 18 inches except for walls on structures or rock as determined by the Engineer. Use a uniform reinforcement length throughout the wall height of at least 0.7H or 6 feet, whichever is longer. Extend the reinforced zone at least 6 inches beyond end of reinforcement. Do not locate the reinforced zone outside right-of-way or easement limits.

Use the simplified method for determining maximum reinforcement loads in accordance with the *AASHTO LRFD specifications*. For geotextile reinforcement, use geotextile properties approved by the Department or default values in accordance with the *AASHTO LRFD specifications*. For geogrid and geostrip reinforcement, use approved geosynthetic reinforcement properties available from the website shown elsewhere in this provision. Use geosynthetic properties for the direction reinforcement will be installed, a 3-year design life and shoring backfill to be used in the reinforced zone.

Do not use more than 4 different reinforcement strengths for each temporary geosynthetic wall. Design temporary geotextile walls for a reinforcement coverage ratio ( $R_c$ ) of 1.0. For temporary geogrid walls with an  $R_c$  of less than

1.0, use a maximum horizontal clearance between geogrids of 3 feet and stagger reinforcement so geogrids are centered over gaps in the reinforcement layer below.

For temporary geosynthetic walls, use “L” shaped welded wire facing with 18 to 24 inch long legs. Locate geosynthetic reinforcement so reinforcement layers are at the same level as the horizontal legs of welded wire facing. Use vertical reinforcement spacing equal to facing height. Wrap geotextile or geogrid reinforcement behind welded wire facing and extend reinforcement at least 3 feet back behind facing into shoring backfill. Attach geostrip reinforcement to welded wire facing with a connection approved by the Department.

For temporary wire walls with separate reinforcement and facing components, attach welded wire grid or metallic strip reinforcement to welded wire facing with a connection approved by the Department. For temporary geogrid, geostrip and wire walls, retain shoring backfill at welded wire facing with retention geotextiles and extend geotextiles at least 3 feet back behind facing into backfill.

(D) Preconstruction Meeting

The Engineer may require a shoring preconstruction meeting to discuss the construction, inspection and testing of the temporary shoring. If required and if this meeting occurs before all shoring submittals have been accepted, additional preconstruction meetings may be required before beginning construction of temporary shoring without accepted submittals. The Resident, District or Bridge Maintenance Engineer, Area Construction Engineer, Geotechnical Operations Engineer, Contractor and Shoring Contractor Superintendent will attend preconstruction meetings.

### Construction Methods

Control drainage during construction in the vicinity of shoring. Direct run off away from shoring and shoring backfill. Contain and maintain backfill and protect material from erosion.

Install positive protection in accordance with the contract and accepted submittals. Use PCB in accordance with Section 1170 of the *Standard Specifications* and *Roadway Standard Drawing* No. 1170.01. Use temporary guardrail in accordance with Section 862 of the *Standard Specifications* and *Roadway Standard Drawing* Nos. 862.01, 862.02 and 862.03.

(A) Tolerances

Construct shoring with the following tolerances:

- (1) Horizontal wires of welded wire facing are level in all directions,
- (2) Shoring location is within 6 inches of horizontal and vertical alignment shown in the accepted submittals, and
- (3) Shoring plumbness (batter) is not negative and within 2 degrees of vertical.



(B) Cantilever, Braced and Anchored Shoring Installation

If overexcavation behind cantilever, braced or anchored shoring is shown in the accepted submittals, excavate before installing piles. Otherwise, install piles before excavating for shoring. Install cantilever, braced or anchored shoring in accordance with the construction sequence shown in the accepted submittals. Remove piles and if applicable, timber lagging when shoring is no longer needed.

(1) Pile Installation

Install piles with the minimum required embedment and extension in accordance with Subarticles 450-3(D) and 450-3(E) of the *Standard Specifications* except that a pile driving equipment data form is not required. Piles may be installed with a vibratory hammer as approved by the Engineer.

Do not splice sheet piles. Use pile excavation to install drilled-in H-piles. After filling holes with concrete or Type 1 grout to the elevations shown in the accepted submittals, remove any fluids and fill remaining portions of holes with flowable fill. Cure concrete or grout at least 7 days before excavating.

Notify the Engineer if refusal is reached before pile excavation or driven piles attain the minimum required embedment. When this occurs, a revised design submittal may be required.

(2) Excavation

Excavate in front of piles from the top down in accordance with the accepted submittals. For H-piles with timber lagging and braced and anchored shoring, excavate in staged horizontal lifts with a maximum height of 5 feet. Remove flowable fill and material in between H-piles as needed to install timber lagging. Position lagging with at least 3 inches of contact in the horizontal direction between the lagging and pile flanges. Do not excavate the next lift until timber lagging for the current lift is installed and if applicable, bracing and anchors for the current lift are accepted. Backfill behind cantilever, braced or anchored shoring with shoring backfill.

(3) Anchor Installation

If applicable, install foundations located behind anchored shoring before installing anchors. Fabricate and install ground anchors in accordance with the accepted submittals, Articles 6.4 and 6.5 of the *AASHTO LRFD Bridge Construction Specifications* and the following unless otherwise approved:

- (a) Materials in accordance with this provision are required instead of materials conforming to Articles 6.4 and 6.5.3 of the *AASHTO LRFD Specifications*,

- (b) Encapsulation-protected ground anchors in accordance with Article 6.4.1.2 of the AASHTO LRFD specifications are not required, and
- (c) Corrosion protection for unbonded lengths of ground anchors and anchorage covers are not required.
- (d) Mix and place neat cement grout in accordance with Subarticles 1003-5, 1003-6 and 1003-7 of the *Standard Specifications*. Measure grout temperature, density and flow during grouting with at least the same frequency grout cubes are made for compressive strength. Perform density and flow field tests in the presence of the Engineer in accordance with American National Standards Institute/American Petroleum Institute Recommended Practice 13B-1 (Section 4, Mud Balance) and ASTM C939 (Flow Cone), respectively.

Install helical anchors in accordance with the accepted submittals and Anchor Manufacturer's instructions. Measure torque during installation and do not exceed the torsional strength rating of the helical anchor. Attain the minimum required installation torque and penetration before terminating anchor installation. When replacing a helical anchor, embed last helix of the replacement anchor at least 3 helix plate diameters past the location of the first helix of the previous anchor.

(4) Anchor Testing

Proof test and lock-off anchors in accordance with the accepted submittals and Article 6.5.5 of the *AASHTO LRFD Bridge Construction Specifications* except for the acceptance criteria in Article 6.5.5.5. For the AASHTO LRFD specifications, "ground anchor" refers to a ground or helical anchor and "tendon" refers to a bar, strand or shaft.

(a) Anchor Acceptance

Anchor acceptance is based in part on the following criteria.

- (i) For ground and helical anchors, total movement is less than 0.04 inches between the 1 and 10 minute readings or less than 0.08 inches between the 6 and 60 minute readings.
- (ii) For ground anchors, total movement at maximum test load exceeds 80% of the theoretical elastic elongation of the unbonded length.

(b) Anchor Test Results

Submit PDF files of anchor test records including movement versus load plots for each load increment within 24 hours of completing each row of anchors. The Engineer will review the test records to determine if the anchors are acceptable.

If the Engineer determines an anchor is unacceptable, revise the anchor design or installation methods. Submit a revised anchored shoring design for acceptance and provide an acceptable anchor with the revised design or installation methods. If required, replace the anchor or provide additional anchors with the revised design or installation methods.

(C) Temporary Wall Installation

Excavate as necessary for temporary walls in accordance with the plans and accepted submittals. If applicable, install foundations located in the reinforced zone before placing shoring backfill or reinforcement unless otherwise approved. Notify the Engineer when foundation excavation is complete. Do not place shoring backfill or reinforcement until excavation dimensions and foundation material are approved.

Erect welded wire facing so the wall position is as shown in the plans and accepted submittals. Set welded wire facing adjacent to each other in the horizontal and vertical direction to completely cover the wall face with facing. Stagger welded wire facing to create a running bond by centering facing over joints in the row below.

Attach geostrip reinforcement to welded wire facing and wrap geotextile reinforcement and retention geotextiles behind welded wire facing as shown in the plans and accepted submittals. Cover geotextiles with at least 3" of shoring backfill. Overlap adjacent geotextile reinforcement and retention and separation geotextiles at least 18 inches with seams oriented perpendicular to the wall face. Hold geotextiles in place with wire staples or anchor pins as needed.

Place reinforcement within 3 inches of locations shown in the plans and accepted submittals. Before placing shoring backfill, pull geosynthetic reinforcement taut so it is in tension and free of kinks, folds, wrinkles or creases. Install reinforcement with the direction shown in the plans and accepted submittals. For temporary wire walls with separate reinforcement and facing components, attach welded wire grid or metallic strip reinforcement to welded wire facing as shown in the accepted submittals. Do not splice or overlap reinforcement so seams are parallel to the wall face. Contact the Engineer when unanticipated existing or future obstructions such as foundations, pavements, pipes, inlets or utilities will interfere with reinforcement.

Place shoring backfill in the reinforced zone in 8 to 10 inch thick lifts. Compact A-2-4 soil and Class II, Type 1 and Class III select material in accordance with Subarticle 235-3(C) of the *Standard Specifications*. Use only hand operated compaction equipment to compact backfill within 3 feet of welded wire facing. At a distance greater than 3 feet, compact shoring backfill with at least 4 passes of an 8 to 10 ton vibratory roller in a direction parallel to the wall face. Smooth wheeled or rubber tired rollers are also acceptable for compacting backfill. Do not use sheepsfoot, grid rollers or other types of compaction equipment with feet. Do not displace or damage reinforcement when placing and compacting shoring backfill. End dumping directly on geosynthetics is not permitted. Do not operate heavy equipment on reinforcement until it is covered with at least 8 inches of shoring backfill. Replace any damaged reinforcement to the satisfaction of the Engineer.

Backfill for temporary walls outside the reinforced zone in accordance with Article 410-8 of the *Standard Specifications*. Bench temporary walls into the sides of excavations where applicable. For temporary geosynthetic walls with top of wall within 5 feet of finished grade, remove top facing and incorporate top reinforcement layer into fill when placing fill in front of wall. Temporary walls remain in place permanently unless otherwise required.

### **Measurement and Payment**

*Temporary Shoring* will be measured and paid in square feet. Temporary walls will be measured as the square feet of exposed wall face area. Cantilever, braced or anchored shoring will be measured as the square feet of exposed shoring face area with the shoring height equal to the difference between the top and bottom of shoring elevations. Define “top of shoring” as where the grade intersects the back of sheet piles or H-piles and timber lagging. Define “bottom of shoring” as where the grade intersects front of sheet piles or H-piles and timber lagging. No measurement will be made for any embedment, shoring extension above top of shoring or pavement thickness above temporary walls.

The contract unit price for *Temporary Shoring* will be full compensation for providing shoring designs, submittals and materials, excavating, backfilling, hauling and removing excavated materials and supplying all labor, tools, equipment and incidentals necessary to construct temporary shoring.

No payment will be made for temporary shoring not shown in the plans or required by the Engineer including shoring for OSHA reasons or the Contractor’s convenience. No value engineering proposals will be accepted based solely on revising or eliminating shoring locations shown in the plans or estimated quantities shown in the bid item sheets as a result of actual field measurements or site conditions.

PCB will be measured and paid in accordance with Article 1170-4 of the *Standard Specifications*. No additional payment will be made for anchoring PCB for temporary shoring. Costs for anchoring PCB will be incidental to temporary shoring.

Temporary guardrail will be measured and paid for in accordance with Article 862-6 of the *Standard Specifications*.

Payment will be made under:

#### **Pay Item**

Temporary Shoring

#### **Pay Unit**

Square Foot

**CONES:**

(3-19-24)

1135

SP11 R35

Revise the *Standard Specifications* as follows:

**Page 11-11, Article 1135-3 CONSTRUCTION METHODS, lines 19-20**, delete the third sentence of the first paragraph, "Do not use cones in the upstream taper of lane or shoulder closures for multi-lane roadways."

**FLAGGERS:**

(12-17-24)

1150

SP11 R50

Revise Section 1150 of the *Standard Specification* as follows:

**Page 11-13, Article 1150-1, DESCRIPTION**, add the following after line 31:

Alternatively, at the discretion of the Contractor, the Contractor may furnish, install, place in operation, repair, maintain, relocate, and remove remotely controlled Automated Flagging Assistance Devices (AFAD) or Temporary Portable Traffic Signal units (PTS units) to assist, supplement, or replace human flaggers for one-lane, two-way traffic maintenance during construction in accordance with this provision and the *Standard Specifications*.

For the purpose of this provision, an "approach" refers to a single lane of traffic moving in one direction toward a point of control or work zone. Flaggers, AFAD and PTS units are only used to control one lane of approaching traffic in a specific direction.

**Page 11-13, Article 1150-2, MATERIALS**, add the following after line 34:

Provide documentation to the Engineer that the AFAD or PTS units meets or exceeds the requirements of this special provision and is on the NCDOT APL or ITS and Signals QPL.

**(A) Automated Flagging Assistance Devices (AFAD)**

**(1) AFAD General**

Cover the automated gate arm with Department approved Type VII, VIII or IX retroreflective sheeting of vertical alternating red and white stripes at 16 inch intervals measured horizontally. When the gate arm is in the down position the minimum vertical aspect of the arm and sheeting shall be 4 inches. The retroreflectorized sheeting shall be on both sides of the gate arm. With the AFAD parked or positioned 2 feet outside or in a location deemed acceptable for the lane being controlled, the gate arm shall reach at least to the center of the lane but shall not exceed the width of the lane being controlled.

Design the system to be fail-safe. Provide a conflict monitor, malfunction monitoring unit, or similar device that monitors for malfunctions and prevents the display of conflicting indications. This system shall be electronic and operated by remote control.

**(2) AFAD Type I System: RED/YELLOW**

Provide a Red/Yellow AFAD with at least one set of CIRCULAR RED and CIRCULAR YELLOW lenses in a vertical configuration that are 12 inches in diameter. The bottom of the housing (including brackets) shall be at least 7 feet (2.1 meters) above the pavement.

This system is required to have yellow 12 inch aluminum or polycarbonate vehicle signal heads with 10 inch tunnel visors, backplates, and Light Emitting Diode (LED) modules. Provide signal heads, backplates, and LED modules listed on the ITS and Signals QPL available on the Department's website.

Provide an automated gate arm on the AFAD that descends to a down position across the approaching lane of traffic when the steady CIRCULAR RED lens is illuminated and then ascends to an upright position when the flashing CIRCULAR YELLOW lens is illuminated. The automated gate arm is to be designed such that if a motorist pulls underneath the gate arm while lowering, no damage to the vehicle occurs.

A STOP HERE ON RED (R10-6 or R10-6a) sign shall be installed on the right-hand side of the approach at the point at which drivers are expected to stop when the steady CIRCULAR RED lens is illuminated.

**To stop traffic, the AFAD shall transition from the flashing CIRCULAR YELLOW lens by initiating a minimum 5 second steadily illuminated CIRCULAR YELLOW lens followed by the CIRCULAR RED lens.**

**Once the CIRCULAR RED lens is displayed, the system is to have a minimum 2 second delay between the time the steady CIRCULAR RED is displayed and the time the gate arm begins to lower. The maximum delay between CIRCULAR RED and the time the gate arm lowers is 4 seconds. To permit stopped road users to proceed, the AFAD shall display the flashing CIRCULAR YELLOW lens and the gate arm shall be placed in the upright position.**

Ensure the system monitors for a lack of yellow or red signal voltage, total loss of indication in any direction, presence of multiple indications on any approach and low power conditions.

Additional sets of CIRCULAR RED and CIRCULAR YELLOW lenses located over the roadway or on the left side of the approach and operated in unison with the primary set, may be used to improve visibility of the AFAD. If the set of lenses is located over any portion of the roadway that can be used by motor vehicles, the bottom of the housing (including brackets) shall be at least 15 feet (4.6 meters) above the pavement.

### **(3) AFAD Type II System: STOP/SLOW**

Provide STOP/SLOW signs that are octagonal in shape, made of rigid material, and at least 36 inch x 36 inch in size. Letters shall be a minimum of 8 inches high. The STOP face shall have a red background with white letters and border.

The SLOW face shall be diamond shaped, orange, or yellow background with black letters and border. Cover both faces in a Department approved Type VII, VIII or IX

retroreflective sheeting. The minimum mounting height for the sign faces shall be 7 feet above the pavement to the bottom of the sign.

The AFAD's STOP/SLOW signs shall be supplemented with active conspicuity devices by incorporating a stop beacon (red lens) and a warning beacon (yellow lens). The stop beacon shall be no more than 24 inches above the STOP face. Mount the warning beacon no more than 24 inches above or beside of the SLOW face. Except for the mounting locations, the beacons shall conform to the provisions of Chapter 4L of the MUTCD and have 12 inch signal lenses.

Strobe/flashing lights are an acceptable alternative to flashing beacons. If utilized, they shall be either white or red flashing lights located within the STOP face and white or yellow flashing lights within the SLOW face and conform to the provisions of Chapter 6D of the MUTCD. If used, the lens diameter shall be a minimum of 5 inches with a minimum height of 6 inches. Equip strobes/flashing lights for both dual and quad flash patterns.

Type B warning lights shall not be used in lieu of the beacons or the strobe lights.

The faces of the AFADs STOP/SLOW sign may include louvers. If louvers are used, design the louvers such that the aspect of the sign face to approaching traffic is a full sign face at a distance of 50 feet or greater.

A WAIT ON STOP (R1-7) sign and a GO ON SLOW (R1-8) sign shall be displayed to traffic approaching the AFAD. Position signs on the same support structure as the AFAD. Both signs shall have black legends and borders on white Type III sheeting backgrounds. Each of these signs shall be rectangular in shape and be at least 24 inch x 30 inch size with letters at least 6 inches high.

Provide an automated gate arm on the AFAD that descends to a down position across the approaching lane of traffic when the STOP face is displayed and then ascends to an upright position when the SLOW face is displayed.

The automated gate arm is to be designed such that if a motorist pulls underneath the gate arm while lowering, no damage to the vehicle occurs.

A STOP HERE ON RED (R10-6 or R10-6a) sign shall be installed on the right-hand side of the approach at the point at which drivers are expected to stop when the STOP face is displayed.

When approaching motorists are to proceed, display the SLOW face and the warning beacon or strobes are to flash on the AFAD. When approaching motorists are will be stopped, display the STOP face and the stop beacon or strobes are to flash on the AFAD.

**To stop traffic, the AFAD will transition from the SLOW face to the STOP face by initiating a minimum 5 second change cycle. First, the warning beacon is to be steadily illuminated for the change cycle. If strobes are used in lieu of a warning beacon, they are to be placed in the quad flash pattern. At the end of the change**

cycle, the STOP face is to be displayed with the stop beacon flashing and the warning beacon or strobes are to stop flashing. Once the STOP face is displayed, the system is to have a minimum 2 second delay between the time the STOP face is displayed and the time the gate arm begins to lower. The maximum delay between the time the STOP face is displayed and the time the gate arm lowers is 4 seconds.

To permit stopped road users to proceed, the gate arm shall be placed in the upright position and the AFAD shall display the SLOW face and the warning beacon or strobes are to flash in the dual flash pattern.

Do not flash the stop beacon when the SLOW face is displayed, and do not flash the warning beacon when the STOP face is displayed.

### **(B) Portable Traffic Signals (PTS) Units**

Provide PTS units with at least one set of CIRCULAR RED, CIRCULAR YELLOW, and CIRCULAR GREEN lenses in a vertical configuration that are 12 inch diameter aluminum or polycarbonate vehicle signal heads with 10 inch tunnel visors, backplates, and Light Emitting Diode (LED) modules. All signal heads, tunnel visors, and backplates shall be yellow in color.

The bottom of the housing (including brackets) shall be at least 7 feet above the pavement for single set units. Additional signal heads on units with more than one signal head shall be capable of extending over the travel lane.

### **Communication Requirements**

All PTS units within the signal set up systems shall maintain communication at all times by either hardwire cable or wireless radio link communication. If the hardwire cable communication is utilized the communication cable shall be deployed in a manner that will not intrude in the direct work area of the project or obstruct vehicular and pedestrian traffic. Utilize radio communication with 900MHz frequency band and frequency hopping capability. The radio link communication system shall have a minimum range of 1 mile.

### **Fault Mode Requirements**

Revert PTS units to a flashing red mode upon system default unless otherwise specified by the Engineer. Equip the PTS units with a remote monitoring system. Where cell communication availability exists, the remote monitoring system shall adhere to the remote monitoring system section of this provision.

### **Remote Monitoring System**

The remote monitoring system (RMS) shall be capable of reporting signal location, battery voltage / battery history and system default. Provide a password protected website viewable from any computer with internet capability for the RMS. In the event



of a system default, the RMS shall provide specific information concerning the cause of the system default (i.e. red lamp on signal number 1). Equip the RMS with a mechanism capable of immediately contacting a minimum of three previously designated individuals via text messaging and/or email upon a default.

The running program operating the PTS units shall be always available and viewable through the RMS website. Maintain a history of the RMS operating system in each signal including operating hours and events and the location of the PTS units.

### **Trailer / Cart**

The AFAD and PTS units may be mounted on either a trailer or a moveable cart system.

Finish all exterior metal surfaces with Federal orange enamel per AMS-STD-595, color chip ID# 13538 or 12473 respectively with a minimum paint thickness of 2.5 mils (64 microns).

Design and test the AFAD or PTS units trailer / cart to withstand an 80 MPH wind load while in the operational position. Provide independent certification that the assembly meets the design wind load.

Equip the AFAD or PTS units with leveling jacks capable of stabilizing the unit in a horizontal position when located on slopes 6:1 or flatter.

Equip trailers in compliance with North Carolina Law governing motor vehicles and include a 12-volt trailer lighting system complying with *Federal Motor Carrier Safety Regulations 393*, safety chains and a minimum 2 inch ball hitch.

Provide a minimum 4 inch wide strip of fluorescent conspicuity sheeting retroreflective sheeting to the frame of the trailer. Apply the sheeting to all sides of the trailer. The sheeting shall meet the ASTM requirements of Type VII, VIII or IX.

### **Power System**

Design the systems to operate both with and without an external power source. Furnish transmitters, generators, batteries, controls and all other components necessary to operate the device.

Provide equipment that is solar powered and supplemented with a battery backup system that includes a minimum 110/120 VAC powered on-board charging system capable of powering the unit for 7 continuous days with no solar power. Each unit shall also be capable of being powered by standard 110/120 VAC power sources, if applicable.

Locate batteries and electronic controls in a locked, weather and vandal resistant housings.

**Page 11-14, Article 1150-3, CONSTRUCTION METHODS**, add the following after line 11:

Flaggers shall have a path to escape an errant approaching vehicle at all times, unimpeded by barrier, guardrail, guiderail, parked vehicles, construction materials, slopes steeper than 2:1, or

any other obstruction at all times. If an unimpeded path cannot be maintained, the Contractor shall use AFAD or PTS units in lieu of a flagger.

Provide documentation to the Engineer prior to deploying the device that the AFAD or PTS units operator(s) are qualified flagger(s) that have been properly trained through an NCDOT approved training agency or other NCDOT approved training provider and that the qualified flagger(s) have received manufacturer training to operate that specific device. This training shall include proper installation, remote control operation, central control systems and maintenance of the AFAD or PTS units. The training shall take place off the project site where training conditions are removed from live traffic. The documentation shall include the names of the authorized trainer, the trainees, the device on which they have been trained and the date of the training. Provide updated documentation to the Engineer prior to deploying any additional operators.

Install advance warning signs and operate AFADs in accordance with the attached detail drawings in this provision.

Install advance warning signs and operate PTS units in accordance with *NCDOT Roadway Standard Drawings* No. 1101.02, Sheet 17.

AFAD and PTS units shall only be used in situations where there is only one lane of approaching traffic in the direction to be controlled. **At no time shall an AFAD unit controlling traffic through the work area be placed in an autonomous mode and/or left unattended.**

Signal timing and operation of PTS units shall be field verified and accepted by the Engineer before use.

Use AFAD or PTS units in locations where queuing from the AFAD or PTS units will extend to within 150 feet of a signalized intersection or railroad crossing. Do not use AFAD and PTS units as a substitute for or a replacement for a continuously operating temporary traffic control signal as described in Section 6F.84 of the MUTCD.

If used at night, illuminate each AFAD or PTS units as described in Section 6D of the MUTCD.

Provide a complete AFAD or PTS units that is capable of being relocated as traffic conditions demand.

If AFADs or PTS units become inoperative, be prepared at all times to replace the unit with the same type and model of AFAD or PTS units, revert to human flagging operations or terminate all construction activities requiring the use of the AFAD or PTS units until the AFAD or PTS units become operative or qualified human flaggers are available.

When the work requiring the AFAD or PTS units is not pursued for 30 minutes or longer, power off each AFAD or PTS units. Remove the AFAD or PTS units from the travel lane and relocated to a minimum of 5 feet from the edge line. AFAD gate arms shall be in the upright position. Remove all traffic control devices from the road, place two cones by each AFAD or PTS units and all signs associated with the lane closure operation shall be removed or laid down. At the end of each workday, remove all AFADs or PTS units from the roadway and shoulder areas.

Ensure the system's wireless communication links continuously monitor and verify proper transmission and reception of data used to monitor and control each AFAD or PTS units. Ensure ambient mobile or other radio transmissions or adverse weather conditions do not affect the system.

In the event of a loss of communications, immediately display the flashing RED or STOP indication on all AFAD or PTS units.

### **AFAD Specific Construction Methods**

The flagger/operator controlling the AFAD units shall be on the project site at all times. If multiple AFAD units are used, one AFAD unit shall be the Main AFAD unit and all other units shall be remote AFAD units. Ensure that each device meets the physical display and operational characteristics as specified in the MUTCD.

Multiple AFAD units may be controlled with **one** flagger/operator when the AFAD units meet each of the following requirements:

- (1) AFAD units are spaced no greater than the manufacturer's recommendations.
- (2) Both AFAD units can be seen at the same time from the flagger/operator's position, or the AFAD is operating on its own secure network with malfunction detection and notification to the flagger/operator.
- (3) The flagger/operator has an unobstructed view of approaching traffic in both directions from the flagger/operator position or the AFAD is operating on its own secure network, with cameras that provide the flagger/operator an unobstructed view of approaching traffic from both directions. The flagger/operator may control the AFAD units from a pilot vehicle.

If any of the above requirements are not met, flagger/operator control each AFAD unit.

AFAD operators may either control traffic at side streets or driveways between the AFAD units or operate the pilot car while operating the AFAD system if approved by the Engineer. AFAD units must continue to be within clear sight of the operator during these work activities.

**Page 11-14, Article 1150-4, MEASUREMENT AND PAYMENT**, add the following after line 24:

Each AFAD or PTS unit will be measured and paid for as *Flaggers* paid by day in accordance with Article 1150-4 of the *Standard Specifications*. Where the pay item for *Flaggers* is not included in the original contract then no separate payment will be made for this item and payment will be included in the lump sum price bid for *Temporary Traffic Control* found elsewhere in this contract. Each approach controlled by AFAD or PTS units will be measured and paid as one flagger, irrespective of the number of devices used. If multiple PTS units are required to control a single approach, these units will collectively be considered as replacing one flagger.

No separate measurement or payment will be made for AFAD or PTS unit operators, as the cost of such including their training and operational costs shall be included in the unit or lump sum price for *Flaggers* or *Temporary Traffic Control*. Such price and payment also includes the relocation, maintenance, and removal during repair periods of AFAD or PTS units as well as the signal controller, communication, vehicle detection system, traffic signal software of PTS units and any other incidentals necessary to complete the work.

**Red/Yellow Lens AFAD (TYPE I)**

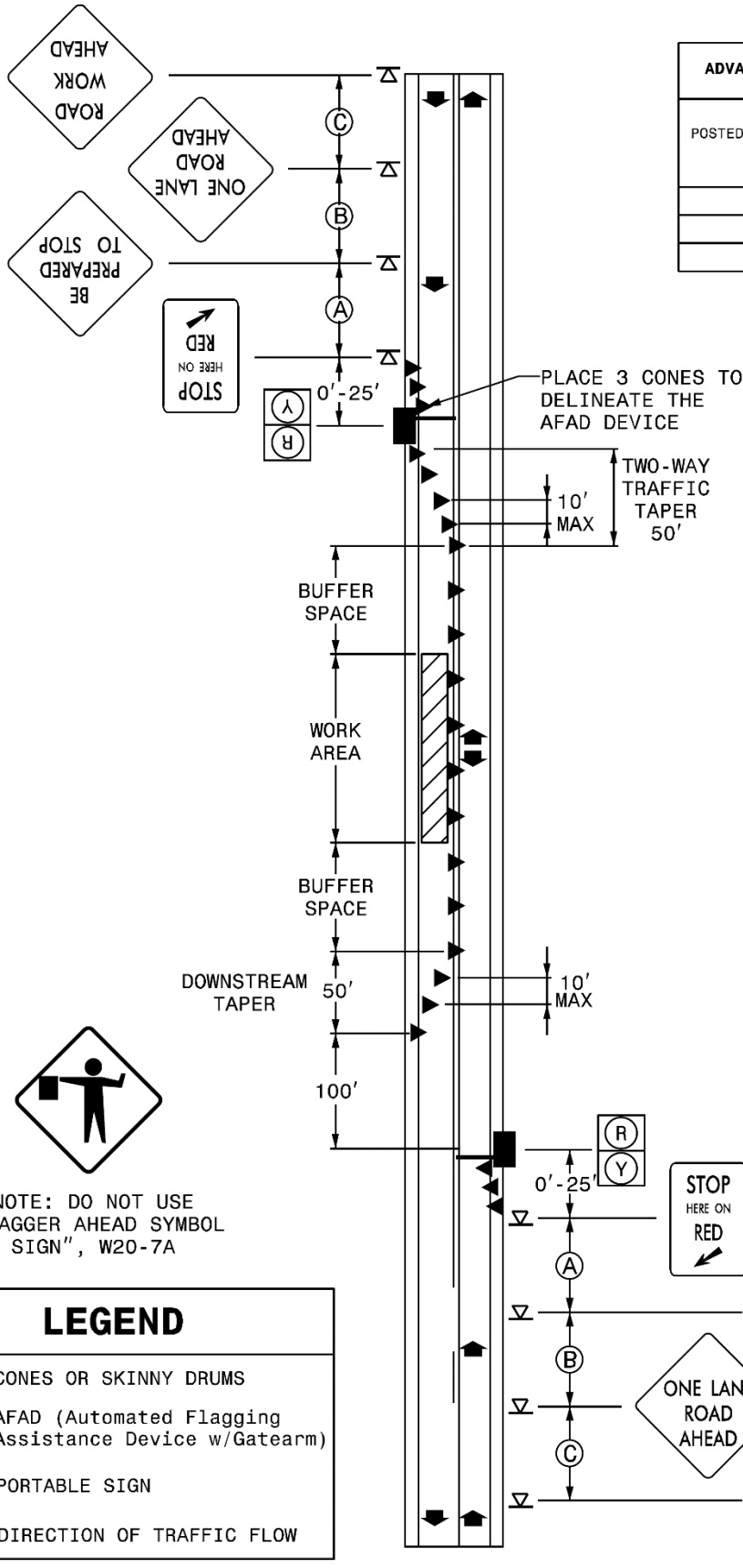

ADVANCE WARNING SIGN SPACING CHART			
POSTED SPEED LIMIT (MPH)	RECOMMENDED DISTANCE BETWEEN SIGNS FEET (+/-) SEE NOTE #1		
	(A)	(B)	(C)
≤ 35	200	200	200
40-50	350	350	350
55	500	500	500

DESIGN SPEED (MPH)	BUFFER SPACE (FEET)
30	85
35	120
40	155
45	195
50	240
55	290
60	345
65	405
70	470
75	540
80	615

NOTE: DO NOT USE "FLAGGER AHEAD SYMBOL SIGN", W20-7A

**LEGEND**

- CONES OR SKINNY DRUMS
- AFAD (Automated Flagging Assistance Device w/Gatearm)
- PORTABLE SIGN
- DIRECTION OF TRAFFIC FLOW

**Stop/Slow AFAD (TYPE II)**



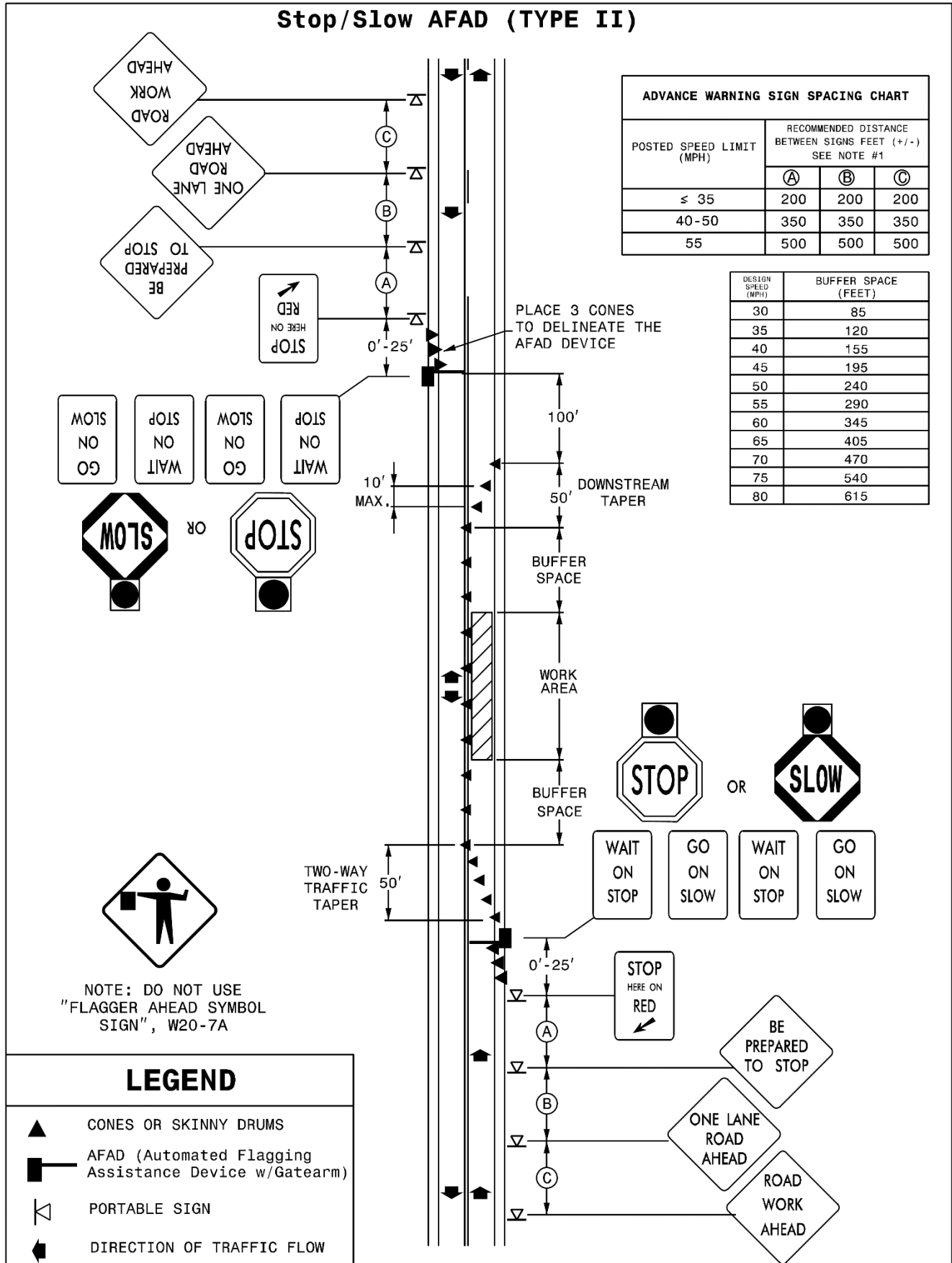

ADVANCE WARNING SIGN SPACING CHART			
POSTED SPEED LIMIT (MPH)	RECOMMENDED DISTANCE BETWEEN SIGNS FEET (+/-) SEE NOTE #1		
	(A)	(B)	(C)
≤ 35	200	200	200
40-50	350	350	350
55	500	500	500

DESIGN SPEED (MPH)	BUFFER SPACE (FEET)
30	85
35	120
40	155
45	195
50	240
55	290
60	345
65	405
70	470
75	540
80	615



NOTE: DO NOT USE "FLAGGER AHEAD SYMBOL SIGN", W20-7A

**LEGEND**

-  CONES OR SKINNY DRUMS
-  AFAD (Automated Flagging Assistance Device w/Gatearm)
-  PORTABLE SIGN
-  DIRECTION OF TRAFFIC FLOW

**PORTABLE CONCRETE BARRIER:**

(12-17-24)

1170

SP11 R70

Revise the *Standard Specifications* as follows:

**Page 11-17, Subarticle 1170-3(A)(1) Portable Concrete Barrier**, after line 25, add the following:

For MASH approved F-Shape K-Wall, install anchorage transitions between unanchored portable concrete barrier and temporary crash cushions, and between unanchored portable concrete barrier and portable concrete barrier (anchored) as shown in the *Roadway Standard Drawings*, No. 1170.01.

**Page 11-19, Article 1170-4 MEASUREMENT AND PAYMENT, line 16**, after the second sentence of the first paragraph add the following:

Crash cushion to unanchored concrete requires a transition

**Page 11-19, Article 1170-4 MEASUREMENT AND PAYMENT, line 13**, delete and replace “*Portable Concrete Barrier (\_\_\_\_)*” with “*Portable Concrete Barrier*”.

**Page 11-19, Article 1170-4 MEASUREMENT AND PAYMENT, line 16**, after the second sentence of the first paragraph add the following:

As shown in the *Roadway Standard Drawings*, No. 1170.01, anchorage transition sections between *Portable Concrete Barrier* and *Temporary Crash Cushions* as found in Section 1160 will be measured and paid as *Portable Concrete Barrier*. No additional payment will be made for equipment, materials or labor to meet the anchorage transition requirements.

**Page 11-19, Article 1170-4 MEASUREMENT AND PAYMENT, line 16**, after the first paragraph add the following:

*Portable Concrete Barrier (Anchored)* will be measured and paid as the maximum number of linear feet furnished, satisfactorily installed, accepted by the Engineer, maintained and removed, at any one time during the life of the project, including anchorage transition sections between portable concrete barrier and portable concrete barrier (anchored) as shown in the *Roadway Standard Drawings*, No. 1170.01. Measurement will be made by counting the number of barrier units used and multiplying by the length of a unit.

**Page 11-19, Article 1170-4 MEASUREMENT AND PAYMENT, line 21**, delete and replace “*Remove and Reset Portable Concrete Barrier (\_\_\_\_)*” with “*Remove and Reset Portable Concrete Barrier*”.

**Page 11-19, Article 1170-4 MEASUREMENT AND PAYMENT, line 24**, after the second sentence of the third paragraph add the following:

As shown in the *Roadway Standard Drawings*, No. 1170.01, anchorage transition sections between *Portable Concrete Barrier* and *Temporary Crash Cushions* as found in Section 1160 will be measured and paid as *Remove and Reset Portable Concrete Barrier*. No additional

payment will be made for equipment, materials or labor to meet the anchorage transition requirements.

**Page 11-19, Article 1170-4 MEASUREMENT AND PAYMENT, line 28**, after the third paragraph add the following:

*Remove and Reset Portable Concrete Barrier (Anchored)* will be measured and paid as the number of linear feet of barrier moved from one location on the project to another location on the project, including anchorage transition sections between portable concrete barrier and portable concrete barrier (anchored) as shown in the Roadway Standard Drawings, No. 1170.01. Measurement will be made by counting the number of barrier units moved during any one move and multiplying by the length of a unit. Where barrier units are moved more than once, each move will be measured separately. Whenever the Engineer directs the Contractor to move barrier units from an installed location to a stockpile either on or off the project and then back to another installed location, the complete move from the first installed location to the next installed location will be measured as 2 moves.

**SNOWPLOWABLE DELINEATION:**

(10-15-24)

1253

SP12 R53

**Description**

Furnish, install and maintain snowplowable delineation.

There are five snowplowable delineation alternate options approved for use in North Carolina. They include the following markers and markings options:

- (1) Polycarbonate H-shaped Markers
- (2) Inlaid Raised Pavement Markers
- (3) 10' Rumble Skips
- (4) Inlaid Cradle Markers
- (5) 10' Inlaid Pavement Markings

Only one type of snowplowable delineation will be allowed on a single project.

**Materials**

Refer to Division 10 of the *Standard Specifications*.

<b>Item</b>	<b>Section</b>
Epoxy	1081
Pavement Markings	1087
Snowplowable Pavement Markers	1086-3

Any snowplowable pavement delineation shall conform to the applicable requirements of Sections 1086, 1087, and 1081 of the *Standards and Specifications*. Use snowplowable delineation markers and markings listed on the NCDOT APL. Any treatment that requires pavement cutting or milling shall be installed within 7 calendar days of the pavement cutting or milling operation.



**Construction Methods****(A) General**

For any snowplowable delineation, prior to installation, by brushing, blow cleaning, vacuuming or other suitable means, ensure that all materials and the pavement surface are free of dirt, grease, dust, oil, moisture, mud, grass, or any other material that would prevent adhesion to the pavement by brushing blow cleaning, or vacuuming. If required, apply a primer per manufactures recommendations to pavement surfaces before applying pavement marking material.

Install snowplowable delineation per manufacturers specifications every 80 feet. Make sure pavement markers are oriented to traffic correctly and pavement markings are applied in a uniform thickness. Do not apply markings over longitudinal joints. Protect the pavement markings until they are tack free. Apply applicable Sections 1205 and 1250 of the *Standards Specifications*.

If damage occurs during installation the effected treatments shall be corrected or replaced. This work shall be considered incidental to the installation of the marking or marker.

**(B) Polycarbonate H-shaped Markers and Inlaid Cradle Markers**

Bond marker housings to the pavement with epoxy adhesive. Mechanically mix and dispense epoxy adhesives as required by the manufacturer's specifications. Place the markers immediately after the adhesive has been mixed and dispensed.

Install polycarbonate H-shaped markers and inlaid cradle markers castings into slots sawcut into the pavement. Make slots in the pavement to exactly duplicate the shape of the casting of the polycarbonate H-shaped markers and inlaid cradle markers.

If saw cutting, milling, or grooving operations are used, promptly remove all resulting debris from the pavement surface. Install the marker housings within 7 calendar days after saw cutting , milling, or grooving the pavement. Remove and dispose of loose material from the slots by brushing, blow cleaning or vacuuming. Dry the slots before applying the epoxy adhesive. Install polycarbonate H-shaped markers and inlaid cradle markers according to the manufacturer's recommendations.

Protect the polycarbonate H-shaped markers or inlaid cradle markers until the epoxy has initially cured and is track free.

Construct inlaid cradle markers in accordance with the details in the plans and as directed by the Engineer.

**(C) Reflector Replacement**

The following requirements only apply to polycarbonate H-shaped markers and inlaid cradle markers.

In the event that a reflector is damaged, replace the damaged reflector by using adhesives and methods recommended by the manufacturer of the markers and approved by the Engineer. This work is considered incidental if damage occurs during the initial installation of the marker housings and maintenance of initial polycarbonate H-shaped markers or inlaid cradle markers specified in this section.

If during reflector replacement it is discovered that the housing is missing or broken this will be paid as *Polycarbonate H-shaped Markers* or *Inlaid Cradle Markers*. Missing housings shall be replaced. Broken housings shall be removed and replaced. In both cases the slot for the housings shall be properly prepared prior to installing the new housing; patch the existing marker slots as directed by the Engineer and install the new marker approximately one foot before or after the patch. Removal of broken housings and preparation of slots will be considered incidental to the work of replacing housings.

**(D) Inlaid Raised Pavement Markers**

Cut groove in accordance with the details in the plans and as directed by the Engineer.

Use adhesive recommended by the manufacturer to install markers into the groove in accordance with Section 1251. The raised pavement markers are incidental to inlaid raised pavement markers.

**(E) 10' Rumble Skips**

Construct 10' rumble skips on asphalt concrete in accordance with Section 665 for all centerline and shoulder rumble skips, details in the plans and as directed by the Engineer. Construct 10' rumble skips on Portland cement concrete in accordance with Section 730 for all centerline and shoulder rumble skips, details in the plans and as directed by the Engineer. The milled rumble strips are incidental to the rumble skips. Using polyurea or extruded 90 mil thermoplastic construct pavement markings in accordance with Section 1205.

**(F) 10' Inlaid Pavement Markings**

The groove in which the marking is to be placed shall be one inch wider than the marking to be placed and 10 mils deeper than the thickness of the marking.

When using this method, use enhanced reflective media. The following retroreflectivity values shall be met.

<b>MINIMUM INITIAL REFLECTOMETER READINGS</b>		
<b>Item</b>	<b>Color</b>	<b>Reflectivity</b>
Enhanced Reflectivity Media	White	450 mcd/lux/m <sup>2</sup>
	Yellow	350 mcd/lux/m <sup>2</sup>

Using polyurea, extruded 90 mil thermoplastic or cold applied plastic construct pavement markings in accordance with Section 1205.

**Maintenance**

Maintain all installed snowplowable delineation before acceptance by the Engineer.

**Measurement and Payment**

*Polycarbonate H-shaped Markers* will be measured and paid as the actual number of polycarbonate H-shaped markers satisfactorily placed and accepted by the Engineer.

*Inlaid Raised Pavement Markers* will be measured and paid as the actual number of inlaid raised pavement markers satisfactorily placed and accepted by the Engineer.

*10' Rumble Skips* will be measured and paid as the actual number of rumble skips satisfactorily placed and accepted by the Engineer.

*Inlaid Cradle Markers* will be measured and paid as the actual number of pavement markers satisfactorily placed and accepted by the Engineer.

*10' Inlaid Pavement Markings* will be measured and paid as the actual number of 10' inlaid pavement markings satisfactorily placed and accepted by the Engineer.

*Replace Snowplowable Pavement Marker Reflector* will be measured and paid in accordance with Article 1253-5.

Payment will be made under:

<b>Pay Item</b>	<b>Pay Unit</b>
Polycarbonate H-shaped Markers	Each
Inlaid Raised Pavement Markers	Each
10' Rumble Skips	Each
Inlaid Cradle Markers	Each
10' Inlaid Pavement Markings	Each

**WATTLE DEVICES:**

(1-1-24)

1642

SP16 R01

**Page 16-23, Subarticle 1642-2(B) Wattle**, lines 10-12, delete and replace with the following:

**(B) Wattle and Wattle Barrier**

Wattles shall meet Table 1642-1.

<b>TABLE 1642-1</b>	
<b>100% CURLED WOOD (EXCELSIOR) FIBERS - WATTLE</b>	
<b>Property</b>	<b>Property Value</b>
Minimum Diameter	12 inches
Minimum Density	2.5 pcf +/- 10%
Net Material	Synthetic
Net Openings	1 inch x 1 inch
Net Configuration	Totally Encased
Minimum Weight	20 lb +/- 10% per 10 foot length

Coir Fiber Wattles shall meet Table 1642-2.

<b>TABLE 1642-2</b>	
<b>100% COIR (COCONUT) FIBERS WATTLE</b>	
<b>Property</b>	<b>Property Value</b>
Minimum Diameter	12 inches
Minimum Density	3.5 pcf +/- 10%
Net Material	Coir Fiber
Net Openings	2 inch x 2 inch
Net Strength	90 lb
Minimum Weight	2.6 pcf +/- 10%

Wattle Barriers shall meet Table 1642-3.

<b>TABLE 1642-3</b>	
<b>100% CURLED WOOD (EXCELSIOR) FIBERS – WATTLE BARRIER</b>	
<b>Property</b>	<b>Property Value</b>
Minimum Diameter	18 inches
Minimum Density	2.9 pcf +/- 10%
Net Material	Synthetic
Net Openings	1 inch x 1 inch
Net Configuration	Totally Encased
Minimum Weight	5 pcf +/- 10%

Coir Fiber Wattle Barriers shall meet Table 1642-4.

<b>TABLE 1642-4</b>	
<b>100% COIR (COCONUT) FIBERS WATTLE BARRIER</b>	
<b>Property</b>	<b>Property Value</b>
Minimum Diameter	18 inches
Minimum Density	5 pcf +/- 10%
Net Material	Coir Fiber
Net Openings	2 inch x 2 inch
Net Strength	90 lb
Minimum Weight	10 pcf +/- 10%

**Pages 16-24 & 16-25, Article 1642-5 MEASUREMENT AND PAYMENT**, lines 42-47 & lines 1-2, delete and replace with the following:

*Wattle* will be measured and paid for by the actual number of linear feet of wattles which are installed and accepted. Such price and payment will be full compensation for all work covered by this section, including, but not limited to, furnishing all materials, labor, equipment and incidentals necessary to install the *Wattle*.

*Coir Fiber Wattles* will be measured and paid for by the actual number of linear feet of coir fiber wattles which are installed and accepted. Such price and payment will be full compensation for all work covered by this section, including, but not limited to, furnishing all materials, labor, equipment and incidentals necessary to install the *Coir Fiber Wattles*.

*Wattle Barrier* will be measured and paid as the actual number of linear feet of wattle barrier installed and accepted. Such price and payment will be full compensation for all work covered by this provision, including, but not limited to, furnishing all materials, labor, equipment and incidentals necessary to install the *Wattle Barrier*.

*Coir Fiber Wattle Barrier* will be measured and paid as the actual number of linear feet of coir fiber wattle barrier installed and accepted. Such price and payment will be full compensation for all work covered by this provision, including, but not limited to, furnishing all materials, labor, equipment and incidentals necessary to install the *Coir Fiber Wattle Barrier*.

**Page 16-25, Article 1642-5 MEASUREMENT AND PAYMENT**, after line 9, delete and replace “\_\_\_ Wattle Check” with “Wattle”.

**Page 16-25, Article 1642-5 MEASUREMENT AND PAYMENT**, after line 9, delete and replace “\_\_\_ Wattle Barrier” with “Wattle Barrier”.

**Page 16-25, Article 1642-5 MEASUREMENT AND PAYMENT**, after line 9, add the following:

<b>Pay Item</b>	<b>Pay Unit</b>
Coir Fiber Wattle	Linear Foot
Coir Fiber Wattle Barrier	Linear Foot

**PERMANENT SEEDING AND MULCHING:**

(7-1-95)(Rev. 1-16-24)

1660

SP16 R02

The Department desires that permanent seeding and mulching be established on this project as soon as practical after slopes or portions of slopes have been graded. As an incentive to obtain an early stand of vegetation on this project, the Contractor's attention is called to the following:

For all permanent seeding and mulching that is satisfactorily completed in accordance with the requirements of Section 1660 in the *Standard Specifications* and within the following percentages of elapsed contract times, an additional payment will be made to the Contractor as an incentive additive. The incentive additive will be determined by multiplying the number of acres of seeding and mulching satisfactorily completed times the contract unit bid price per acre for Seeding and Mulching times the appropriate percentage additive.

<b>Percentage of Elapsed Contract Time</b>	<b>Percentage Additive</b>
0% - 30%	30%
30.01% - 50%	15%

Percentage of elapsed contract time is defined as the number of calendar days from the date of availability of the contract to the date the permanent seeding and mulching is acceptably completed divided by the total original contract time.

**STANDARD SPECIAL PROVISION**  
**AVAILABILITY OF FUNDS – TERMINATION OF CONTRACTS**

(5-20-08)(Rev. 1-16-24)

Z-2

*General Statute 143C-6-11. (h) Highway Appropriation* is hereby incorporated verbatim in this contract as follows:

(h) Amounts Encumbered. – Transportation project appropriations may be encumbered in the amount of allotments made to the Department of Transportation by the Director for the estimated payments for transportation project contract work to be performed in the appropriation fiscal year. The allotments shall be multiyear allotments and shall be based on estimated revenues and shall be subject to the maximum contract authority contained in *General Statute 143C-6-11(c)*. Payment for transportation project work performed pursuant to contract in any fiscal year other than the current fiscal year is subject to appropriations by the General Assembly. Transportation project contracts shall contain a schedule of estimated completion progress, and any acceleration of this progress shall be subject to the approval of the Department of Transportation provided funds are available. The State reserves the right to terminate or suspend any transportation project contract, and any transportation project contract shall be so terminated or suspended if funds will not be available for payment of the work to be performed during that fiscal year pursuant to the contract. In the event of termination of any contract, the contractor shall be given a written notice of termination at least 60 days before completion of scheduled work for which funds are available. In the event of termination, the contractor shall be paid for the work already performed in accordance with the contract specifications.

Payment will be made on any contract terminated pursuant to the special provision in accordance with Subarticle 108-13(D) of the *Standard Specifications*.

**STANDARD SPECIAL PROVISION**  
**NCDOT GENERAL SEED SPECIFICATION FOR SEED QUALITY**

(5-17-11)

Z-3

Seed shall be sampled and tested by the North Carolina Department of Agriculture and Consumer Services, Seed Testing Laboratory. When said samples are collected, the vendor shall supply an independent laboratory report for each lot to be tested. Results from seed so sampled shall be final. Seed not meeting the specifications shall be rejected by the Department of Transportation and shall not be delivered to North Carolina Department of Transportation warehouses. If seed has been delivered it shall be available for pickup and replacement at the supplier's expense.

Any re-labeling required by the North Carolina Department of Agriculture and Consumer Services, Seed Testing Laboratory, that would cause the label to reflect as otherwise specified herein shall be rejected by the North Carolina Department of Transportation.

Seed shall be free from seeds of the noxious weeds Johnsongrass, Balloonvine, Jimsonweed, Witchweed, Itchgrass, Serrated Tussock, Showy Crotalaria, Smooth Crotalaria, Sicklepod, Sandbur, Wild Onion, and Wild Garlic. Seed shall not be labeled with the above weed species on the seed analysis label. Tolerances as applied by the Association of Official Seed Analysts will NOT be allowed for the above noxious weeds except for Wild Onion and Wild Garlic.

Tolerances established by the Association of Official Seed Analysts will generally be recognized. However, for the purpose of figuring pure live seed, the found pure seed and found germination percentages as reported by the North Carolina Department of Agriculture and Consumer Services, Seed Testing Laboratory will be used. Allowances, as established by the NCDOT, will be recognized for minimum pure live seed as listed on the following pages.

The specifications for restricted noxious weed seed refers to the number per pound as follows:

<b><u>Restricted Noxious Weed</u></b>	<b><u>Limitations per Lb. Of Seed</u></b>	<b><u>Restricted Noxious Weed</u></b>	<b><u>Limitations per Lb. of Seed</u></b>
Blessed Thistle	4 seeds	Cornflower (Ragged Robin)	27 seeds
Cocklebur	4 seeds	Texas Panicum	27 seeds
Spurred Anoda	4 seeds	Bracted Plantain	54 seeds
Velvetleaf	4 seeds	Buckhorn Plantain	54 seeds
Morning-glory	8 seeds	Broadleaf Dock	54 seeds
Corn Cockle	10 seeds	Curly Dock	54 seeds
Wild Radish	12 seeds	Dodder	54 seeds
Purple Nutsedge	27 seeds	Giant Foxtail	54 seeds
Yellow Nutsedge	27 seeds	Horsenettle	54 seeds
Canada Thistle	27 seeds	Quackgrass	54 seeds
Field Bindweed	27 seeds	Wild Mustard	54 seeds
Hedge Bindweed	27 seeds		

Seed of Pensacola Bahiagrass shall not contain more than 7% inert matter, Kentucky Bluegrass, Centipede and Fine or Hard Fescue shall not contain more than 5% inert matter whereas a maximum of 2% inert matter will be allowed on all other kinds of seed. In addition, all seed



shall not contain more than 2% other crop seed nor more than 1% total weed seed. The germination rate as tested by the North Carolina Department of Agriculture shall not fall below 70%, which includes both dormant and hard seed. Seed shall be labeled with not more than 7%, 5% or 2% inert matter (according to above specifications), 2% other crop seed and 1% total weed seed.

Exceptions may be made for minimum pure live seed allowances when cases of seed variety shortages are verified. Pure live seed percentages will be applied in a verified shortage situation. Those purchase orders of deficient seed lots will be credited with the percentage that the seed is deficient.

**FURTHER SPECIFICATIONS FOR EACH SEED GROUP ARE GIVEN BELOW:**

Minimum 85% pure live seed; maximum 1% total weed seed; maximum 2% total other crop seed; maximum 144 restricted noxious weed seed per pound. Seed less than 83% pure live seed will not be approved.

Sericea Lespedeza  
Oats (seeds)

Minimum 80% pure live seed; maximum 1% total weed seed; maximum 2% total other crop; maximum 144 restricted noxious weed seed per pound. Seed less than 78% pure live seed will not be approved.

Tall Fescue (all approved varieties)	Bermudagrass
Kobe Lespedeza	Browntop Millet
Korean Lespedeza	German Millet – Strain R
Weeping Lovegrass	Clover – Red/White/Crimson
Carpetgrass	

Minimum 78% pure live seed; maximum 1% total weed seed; maximum 2% total other crop seed; maximum 144 restricted noxious weed seed per pound. Seed less than 76% pure live seed will not be approved.

Common or Sweet Sundangrass

Minimum 76% pure live seed; maximum 1% total weed seed; maximum 2% total other crop seed; maximum 144 restricted noxious weed seed per pound. Seed less than 74% pure live seed will not be approved.

Rye (grain; all varieties)  
Kentucky Bluegrass (all approved varieties)  
Hard Fescue (all approved varieties)  
Shrub (bicolor) Lespedeza

Minimum 70% pure live seed; maximum 1% total weed seed; maximum 2% total other crop seed; maximum 144 noxious weed seed per pound. Seed less than 70% pure live seed will not be approved.

Centipedegrass	Japanese Millet
Crownvetch	Reed Canary Grass
Pensacola Bahiagrass	Zoysia

Creeping Red Fescue

Minimum 70% pure live seed; maximum 1% total weed seed; maximum 2% total other crop seed; maximum 5% inert matter; maximum 144 restricted noxious weed seed per pound.

Barnyard Grass  
Big Bluestem  
Little Bluestem  
Bristly Locust  
Birdsfoot Trefoil  
Indiangrass  
Orchardgrass  
Switchgrass  
Yellow Blossom Sweet Clover

**STANDARD SPECIAL PROVISION**  
**ERRATA**

(1-16-24)

Z-4

Revise the *2024 Standard Specifications* as follows:

**Division 3**

**Page 3-5, Article 305-2 MATERIALS, after line 16,** replace " 1032-3(A)(7)" with "1032-3" and add the item "Galvanized Corrugated Steel Pipe" with Section "1032-3".

**Page 3-6, Article 310-2 MATERIALS, after line 9,** add the item "Galvanized Corrugated Steel Pipe" with Section "1032-3".

**Division 9**

**Page 9-17, Article 904-4 MEASUREMENT AND PAYMENT, prior to line 1,** replace " Sign Erection, Relocate Type (Ground Mounted)" with "Sign Erection, Relocate Type \_\_\_ (Ground Mounted)".

**Division 10**

**Page 10-51, Article 1024-4 WATER, prior to line 1,** delete the "unpopulated blank row" in Table 1024-2 between "Time of set, deviation from control" and "Chloride Ion Content, Max.".

**Page 10-170, Subarticle 1081-1(C) Requirements, line 4,** replace "maximum" with "minimum".

**Division 11**

**Page 11-15, Article 1160-4 MEASUREMENT AND PAYMENT, line 24,** replace "Where barrier units are moved more than one" with "Where barrier units are moved more than once".

**Division 15**

**Page 15-10, Article 1515-4 MEASUREMENT AND PAYMENT, lines 11,** replace " All piping" with "All labor, the manhole, other materials, excavation, backfilling, piping".

**Division 16**

**Page 16-14, Article 1633-5 MEASUREMENT AND PAYMENT, line 20-24 and prior to line 25,** delete and replace with the following " *Flocculant* will be measured and paid in accordance with Article 1642-5 applied to the temporary rock silt checks."

**Page 16-3, Article 1609-2 MATERIALS, after line 26,** replace "Type 4" with "Type 4a".

**Page 16-25, Article 1644-2 MATERIALS, after line 22,** replace "Type 4" with "Type 4a".

**STANDARD SPECIAL PROVISION****PLANT AND PEST QUARANTINES****(Imported Fire Ant, Gypsy Moth, Witchweed, Emerald Ash Borer, Guava Root Knot Nematode, And Other Noxious Weeds)**

(3-18-03) (Rev. 5-21-19)

Z-04a

**Within Quarantined Area**

This project may be within a county regulated for plant and/or pests. If the project or any part of the Contractor's operations is located within a quarantined area, thoroughly clean all equipment prior to moving out of the quarantined area. Comply with federal/state regulations by obtaining a certificate or limited permit for any regulated article moving from the quarantined area.

**Originating in a Quarantined County**

Obtain a certificate or limited permit issued by the N.C. Department of Agriculture/United States Department of Agriculture. Have the certificate or limited permit accompany the article when it arrives at the project site.

**Contact**

Contact the N.C. Department of Agriculture/United States Department of Agriculture at 1-800-206-9333, 919-707-3730, or <https://www.ncagr.gov/plantindustry/Plant/quaran/table2.htm> to determine those specific project sites located in the quarantined area or for any regulated article used on this project originating in a quarantined county.

**Regulated Articles Include**

1. Soil, sand, gravel, compost, peat, humus, muck, and decomposed manure, separately or with other articles. This includes movement of articles listed above that may be associated with cut/waste, ditch pulling, and shoulder cutting.
2. Plants with roots including grass sod.
3. Plant crowns and roots.
4. Bulbs, corms, rhizomes, and tubers of ornamental plants.
5. Hay, straw, fodder, and plant litter of any kind.
6. Clearing and grubbing debris.
7. Used agricultural cultivating and harvesting equipment.
8. Used earth-moving equipment.
9. Any other products, articles, or means of conveyance, of any character, if determined by an inspector to present a hazard of spreading imported fire ant, gypsy moth, witchweed, emerald ash borer, guava root knot nematode, or other noxious weeds.

**STANDARD SPECIAL PROVISION**

**MINIMUM WAGES**

(7-21-09)

Z-5

**FEDERAL:** The Fair Labor Standards Act provides that with certain exceptions every employer shall pay wages at the rate of not less than SEVEN DOLLARS AND TWENTY FIVE CENTS (\$7.25) per hour.

**STATE:** The North Carolina Minimum Wage Act provides that every employer shall pay to each of his employees, wages at a rate of not less than SEVEN DOLLARS AND TWENTY FIVE CENTS (\$7.25) per hour.

The minimum wage paid to all skilled labor employed on this contract shall be SEVEN DOLLARS AND TWENTY FIVE CENTS (\$7.25) per hour.

The minimum wage paid to all intermediate labor employed on this contract shall be SEVEN DOLLARS AND TWENTY FIVE CENTS (\$7.25) per hour.

The minimum wage paid to all unskilled labor on this contract shall be SEVEN DOLLARS AND TWENTY FIVE CENTS (\$7.25) per hour.

This determination of the intent of the application of this act to the contract on this project is the responsibility of the Contractor.

The Contractor shall have no claim against the Department of Transportation for any changes in the minimum wage laws, Federal or State. It is the responsibility of the Contractor to keep fully informed of all Federal and State Laws affecting his contract.

**STANDARD SPECIAL PROVISION****TITLE VI AND NONDISCRIMINATION:**

(6-28-77)(Rev 1/16/2024)

Z-6

The North Carolina Department of Transportation is committed to carrying out the U.S. Department of Transportation's policy of ensuring nondiscrimination in the award and administration of contracts.

The provisions of this section related to United States Department of Transportation (US DOT) Order 1050.2A, Title 49 Code of Federal Regulations (CFR) part 21, 23 United States Code (U.S.C.) 140 and 23 CFR part 200 (or 49 CFR 303, 49 U.S.C. 5332 or 49 U.S.C. 47123) are applicable to all North Carolina Department of Transportation (NCDOT) contracts and to all related subcontracts, material supply, engineering, architectural and other service contracts, regardless of dollar amount. Any Federal provision that is specifically required not specifically set forth is hereby incorporated by reference.

**(1) Title VI Assurances (USDOT Order 1050.2A, Appendix A)**

During the performance of this contract, the contractor, for itself, its assignees, and successors in interest (hereinafter referred to as the "contractor") agrees as follows:

**(a) Compliance with Regulations**

The contractor (hereinafter includes consultants) shall comply with the Acts and the Regulations relative to Nondiscrimination in Federally-assisted programs of the U.S. Department of Transportation, Federal Highway Administration (FHWA), as they may be amended from time to time, which are herein incorporated by reference and made a part of this contract.

**(b) Nondiscrimination**

The contractor, with regard to the work performed by it during the contract, shall not discriminate on the grounds of race, color, or national origin in the selection and retention of subcontractors, including procurements of materials and leases of equipment. The contractor shall not participate directly or indirectly in the discrimination prohibited by the Acts and the Regulations, including employment practices when the contract covers any activity, project, or program set forth in Appendix B of 49 CFR Part 21.

**(c) Solicitations for Subcontractors, Including Procurements of Materials and Equipment**

In all solicitations, either by competitive bidding, or negotiation made by the contractor for work to be performed under a subcontract, including procurements of materials, or leases of equipment, each potential subcontractor or supplier shall be notified by the contractor of the contractor's obligations under this contract and the Acts and the Regulations relative to Nondiscrimination on the grounds of race, color, or national origin.

**(d) Information and Reports**

The contractor shall provide all information and reports required by the Acts, the Regulations, and directives issued pursuant thereto and shall permit access to its

books, records, accounts, other sources of information, and its facilities as may be determined by the Recipient or the FHWA to be pertinent to ascertain compliance with such Acts, Regulations, and instructions. Where any information required of a contractor is in the exclusive possession of another who fails or refuses to furnish the information, the contractor shall so certify to the Recipient or the FHWA, as appropriate, and shall set forth what efforts it has made to obtain the information.

(e) Sanctions for Noncompliance:

In the event of a contractor's noncompliance with the Non-discrimination provisions of this contract, the Recipient will impose such contract sanctions as it and/or the FHWA may determine to be appropriate, including, but not limited to:

- (i) Withholding payments to the contractor under the contract until the contractor complies; and/or
- (ii) Cancelling, terminating, or suspending a contract, in whole or in part.

(f) Incorporation of Provisions

The contractor shall include the provisions of paragraphs (a) through (f) in every subcontract, including procurements of materials and leases of equipment, unless exempt by the Acts, the Regulations and directives issued pursuant thereto. The contractor shall take action with respect to any subcontract or procurement as the Recipient or the FHWA may direct as a means of enforcing such provisions including sanctions for noncompliance. Provided, that if the contractor becomes involved in, or is threatened with litigation by a subcontractor, or supplier because of such direction, the contractor may request the Recipient to enter into any litigation to protect the interests of the Recipient. In addition, the contractor may request the United States to enter into the litigation to protect the interests of the United States.

**(2) Title VI Nondiscrimination Program (23 CFR 200.5(p))**

The North Carolina Department of Transportation (NCDOT) has assured the USDOT that, as a condition to receiving federal financial assistance, NCDOT will comply with Title VI of the Civil Rights Act of 1964 and all requirements imposed by Title 49 CFR part 21 and related nondiscrimination authorities to ensure that no person shall, on the ground of race, color, national origin, limited English proficiency, sex, age, or disability (including religion/creed or income-level, where applicable), be excluded from participation in, be denied the benefits of, or be subjected to discrimination under any programs, activities, or services conducted or funded by NCDOT. Contractors and other organizations under contract or agreement with NCDOT must also comply with Title VI and related authorities, therefore:

- (a) During the performance of this contract or agreement, contractors (e.g., subcontractors, consultants, vendors, prime contractors) are responsible for complying with NCDOT's Title VI Program. Contractors are not required to prepare or submit Title VI Programs. To comply with this section, the prime contractor shall:
  1. Post NCDOT's Notice of Nondiscrimination and the Contractor's own Equal Employment Opportunity (EEO) Policy in conspicuous locations accessible to all employees, applicants and subcontractors on the jobsite.

2. Physically incorporate the required Title VI clauses into all subcontracts on federally-assisted and state-funded NCDOT projects, and ensure inclusion by subcontractors into all lower-tier subcontracts.
  3. Required Solicitation Language. The Contractor shall include the following notification in all solicitations for bids and requests for work or material, regardless of funding source:

“The North Carolina Department of Transportation, in accordance with the provisions of Title VI of the Civil Rights Act of 1964 (78 Stat. 252, 42 U.S.C. §§ 2000d to 2000d-4) and the Regulations, hereby notifies all bidders that it will affirmatively ensure that any contract entered into pursuant to this advertisement, disadvantaged business enterprises will be afforded full and fair opportunity to submit bids in response to this invitation and will not be discriminated against on the grounds of race, color, or national origin in consideration for an award. In accordance with other related nondiscrimination authorities, bidders and contractors will also not be discriminated against on the grounds of sex, age, disability, low-income level, creed/religion, or limited English proficiency in consideration for an award.”
  4. Physically incorporate the FHWA-1273, in its entirety, into all subcontracts and subsequent lower tier subcontracts on Federal-aid highway construction contracts only.
  5. Provide language assistance services (i.e., written translation and oral interpretation), free of charge, to LEP employees and applicants. Contact NCDOT OCR for further assistance, if needed.
  6. For assistance with these Title VI requirements, contact the NCDOT Title VI Nondiscrimination Program at 1-800-522-0453.
- (b) Subrecipients (e.g. cities, counties, LGAs, planning organizations) may be required to prepare and submit a Title VI Plan to NCDOT, including Title VI Assurances and/or agreements. Subrecipients must also ensure compliance by their contractors and subrecipients with Title VI. (23 CFR 200.9(b)(7))
  - (c) If reviewed or investigated by NCDOT, the contractor or subrecipient agrees to take affirmative action to correct any deficiencies found within a reasonable time period, not to exceed 90 calendar days, unless additional time is granted by NCDOT. (23 CFR 200.9(b)(15))
  - (d) The Contractor is responsible for notifying subcontractors of NCDOT’s External Discrimination Complaints Process.
    1. Applicability

Title VI and related laws protect participants and beneficiaries (e.g., members of the public and contractors) from discrimination by NCDOT employees, subrecipients and contractors, regardless of funding source.



## 2. Eligibility

Any person—or class of persons—who believes he/she has been subjected to discrimination based on race, color, national origin, Limited English Proficiency (LEP), sex, age, or disability (and religion in the context of employment, aviation, or transit) may file a written complaint. The law also prohibits intimidation or retaliation of any sort.

## 3. Time Limits and Filing Options

Complaints may be filed by the affected individual(s) or a representative and must be filed no later than 180 calendar days after the following:

- (i) The date of the alleged act of discrimination; or
- (ii) The date when the person(s) became aware of the alleged discrimination; or
- (iii) Where there has been a continuing course of conduct, the date on which that conduct was discontinued or the latest instance of the conduct.

Title VI and related discrimination complaints may be submitted to the following entities:

- North Carolina Department of Transportation, Office of Civil Rights, Title VI Program, 1511 Mail Service Center, Raleigh, NC 27699-1511; toll free 1-800-522-0453
- Federal Highway Administration, North Carolina Division Office, 310 New Bern Avenue, Suite 410, Raleigh, NC 27601, 919-747-7010
- US Department of Transportation, Departmental Office of Civil Rights, External Civil Rights Programs Division, 1200 New Jersey Avenue, SE, Washington, DC 20590; 202-366-4070

## 4. Format for Complaints

Complaints must be in writing and signed by the complainant(s) or a representative, and include the complainant's name, address, and telephone number. Complaints received by fax or e-mail will be acknowledged and processed. Allegations received by telephone will be reduced to writing and provided to the complainant for confirmation or revision before processing. Complaints will be accepted in other languages, including Braille.

## 5. Discrimination Complaint Form

Contact NCDOT Civil Rights to receive a full copy of the Discrimination Complaint Form and procedures.

## 6. Complaint Basis

Allegations must be based on issues involving race, color, national origin (LEP), sex, age, disability, or religion (in the context of employment, aviation or transit). "Basis" refers to the complainant's membership in a protected group category.

**TABLE 103-1  
COMPLAINT BASIS**

<b>Protected Categories</b>	<b>Definition</b>	<b>Examples</b>	<b>Applicable Nondiscrimination Authorities</b>
Race and Ethnicity	An individual belonging to one of the accepted racial groups; or the perception, based usually on physical characteristics that a person is a member of a racial group	Black/African American, Hispanic/Latino, Asian, American Indian/Alaska Native, Native Hawaiian/Pacific Islander, White	Title VI of the Civil Rights Act of 1964; 49 CFR Part 21; 23 CFR 200; 49 U.S.C. 5332(b); 49 U.S.C. 47123. ( <i>Executive Order 13166</i> )
Color	Color of skin, including shade of skin within a racial group	Black, White, brown, yellow, etc.	
National Origin ( <i>Limited English Proficiency</i> )	Place of birth. Citizenship is not a factor. ( <i>Discrimination based on language or a person's accent is also covered</i> )	Mexican, Cuban, Japanese, Vietnamese, Chinese	
Sex	Gender. The sex of an individual. <i>Note: Sex under this program does not include sexual orientation.</i>	Women and Men	1973 Federal-Aid Highway Act; 49 U.S.C. 5332(b); 49 U.S.C. 47123.
Age	Persons of any age	21-year-old person	Age Discrimination Act of 1975 49 U.S.C. 5332(b); 49 U.S.C. 47123.
Disability	Physical or mental impairment, permanent or temporary, or perceived.	Blind, alcoholic, para-amputee, epileptic, diabetic, arthritic	Section 504 of the Rehabilitation Act of 1973; Americans with Disabilities Act of 1990
Religion (in the context of employment) ( <i>Religion/ Creed in all aspects of any aviation or transit-related construction</i> )	An individual belonging to a religious group; or the perception, based on distinguishable characteristics that a person is a member of a religious group. In practice, actions taken as a result of the moral and ethical beliefs as to what is right and wrong, which are sincerely held with the strength of traditional religious views. <i>Note: Does not have to be associated with a recognized religious group or church; if an individual sincerely holds to the belief, it is a protected religious practice.</i>	Muslim, Christian, Sikh, Hindu, etc.	Title VII of the Civil Rights Act of 1964; 23 CFR 230; FHWA-1273 Required Contract Provisions. ( <i>49 U.S.C. 5332(b); 49 U.S.C. 47123</i> )

### (3) Pertinent Nondiscrimination Authorities

During the performance of this contract, the contractor, for itself, its assignees, and successors in interest agrees to comply with the following non-discrimination statutes and authorities, including, but not limited to:

- (a) Title VI of the Civil Rights Act of 1964 (42 U.S.C. § 2000d et seq., 78 stat. 252), (prohibits discrimination on the basis of race, color, national origin); and 49 CFR Part 21.

- (b) The Uniform Relocation Assistance and Real Property Acquisition Policies Act of 1970, (42 U.S.C. § 4601), (prohibits unfair treatment of persons displaced or whose property has been acquired because of Federal or Federal-aid programs and projects);
- (c) Federal-Aid Highway Act of 1973, (23 U.S.C. § 324 et seq.), (prohibits discrimination on the basis of sex);
- (d) Section 504 of the Rehabilitation Act of 1973, (29 U.S.C. § 794 et seq.), as amended, (prohibits discrimination on the basis of disability) and 49 CFR Part 27;
- (e) The Age Discrimination Act of 1975, as amended, (42 U.S.C. § 6101 et seq.), (prohibits discrimination on the basis of age);
- (f) Airport and Airway Improvement Act of 1982, (49 USC § 471, Section 47123), as amended, (prohibits discrimination based on race, creed, color, national origin, or sex);
- (g) The Civil Rights Restoration Act of 1987, (PL 100-209), (Broadened the scope, coverage and applicability of Title VI of the Civil Rights Act of 1964, The Age Discrimination Act of 1975 and Section 504 of the Rehabilitation Act of 1973, by expanding the definition of the terms "programs or activities" to include all of the programs or activities of the Federal-aid recipients, sub-recipients and contractors, whether such programs or activities are Federally funded or not);
- (h) Titles II and III of the Americans with Disabilities Act, which prohibit discrimination on the basis of disability in the operation of public entities, public and private transportation systems, places of public accommodation, and certain testing entities (42 U.S.C. §§ 12131-12189) as implemented by Department of Transportation regulations at 49 C.F.R. parts 37 and 38;
- (i) The Federal Aviation Administration's Nondiscrimination statute (49 U.S.C. § 47123) (prohibits discrimination on the basis of race, color, national origin, and sex);
- (j) Executive Order 12898, Federal Actions to Address Environmental Justice in Minority Populations and Low-Income Populations, which ensures Nondiscrimination against minority populations by discouraging programs, policies, and activities with disproportionately high and adverse human health or environmental effects on minority and low-income populations;
- (k) Executive Order 13166, Improving Access to Services for Persons with Limited English Proficiency, and resulting agency guidance, national origin discrimination includes discrimination because of Limited English proficiency (LEP). To ensure compliance with Title VI, you must take reasonable steps to ensure that LEP persons have meaningful access to your programs (70 Fed. Reg. at 74087 to 74100);
- (l) Title IX of the Education Amendments of 1972, as amended, which prohibits you from discriminating because of sex in education programs or activities (20 U.S.C. 1681 et seq).
- (m) Title VII of the Civil Rights Act of 1964 (42 U.S.C. § 2000e et seq., Pub. L. 88-352), (prohibits employment discrimination on the basis of race, color, religion, sex, or national origin).

**(4) Additional Title VI Assurances**

*\*\*The following Title VI Assurances (Appendices B, C and D) shall apply, as applicable*

- (a) Clauses for Deeds Transferring United States Property (1050.2A, Appendix B)

The following clauses will be included in deeds effecting or recording the transfer of real property, structures, or improvements thereon, or granting interest therein from the United States pursuant to the provisions of Assurance 4.

NOW, THEREFORE, the U.S. Department of Transportation as authorized by law and upon the condition that the North Carolina Department of Transportation (NCDOT) will accept title to the lands and maintain the project constructed thereon in accordance with the North Carolina General Assembly, the Regulations for the Administration of the Federal-Aid Highway Program, and the policies and procedures prescribed by the Federal Highway Administration of the U.S. Department of Transportation in accordance and in compliance with all requirements imposed by Title 49, Code of Federal Regulations, U.S. Department of Transportation, Subtitle A, Office of the Secretary, Part 21, Nondiscrimination in Federally-assisted programs of the U.S. Department of Transportation pertaining to and effectuating the provisions of Title VI of the Civil Rights Act of 1964 (78 Stat. 252; 42 U.S.C. § 2000d to 2000d-4), does hereby remise, release, quitclaim and convey unto the NCDOT all the right, title and interest of the U.S. Department of Transportation in and to said lands described in Exhibit A attached hereto and made a part hereof.

(HABENDUM CLAUSE)

TO HAVE AND TO HOLD said lands and interests therein unto the North Carolina Department of Transportation (NCDOT) and its successors forever, subject, however, to the covenants, conditions, restrictions and reservations herein contained as follows, which will remain in effect for the period during which the real property or structures are used for a purpose for which Federal financial assistance is extended or for another purpose involving the provision of similar services or benefits and will be binding on the NCDOT, its successors and assigns.

The NCDOT, in consideration of the conveyance of said lands and interests in lands, does hereby covenant and agree as a covenant running with the land for itself, its successors and assigns, that (1) no person will on the grounds of race, color, or national origin, be excluded from participation in, be denied the benefits of, or be otherwise subjected to discrimination with regard to any facility located wholly or in part on, over, or under such lands hereby conveyed [,] [and]\* (2) that the NCDOT will use the lands and interests in lands and interests in lands so conveyed, in compliance with all requirements imposed by or pursuant to Title 49, Code of Federal Regulations, U.S. Department of Transportation, Subtitle A, Office of the Secretary, Part 21, Non-discrimination in Federally-assisted programs of the U.S. Department of Transportation, Effectuation of Title VI of the Civil Rights Act of 1964, and as said Regulations and Acts may be amended [, and (3) that in the event of breach of any of the above-mentioned nondiscrimination conditions, the Department will have a right to enter or re-enter said lands and facilities on said land, and that above described land and facilities will thereon revert to and vest in and become the absolute property of the U.S. Department of Transportation and its assigns as such interest existed prior to this instruction].\*

(\*Reverter clause and related language to be used only when it is determined that such a clause is necessary in order to make clear the purpose of Title VI.)

(b) Clauses for Transfer of Real Property Acquired or Improved Under the Activity, Facility, or Program (1050.2A, Appendix C)

The following clauses will be included in deeds, licenses, leases, permits, or similar instruments entered into by the North Carolina Department of Transportation (NCDOT) pursuant to the provisions of Assurance 7(a):

1. The (grantee, lessee, permittee, etc. as appropriate) for himself/herself, his/her heirs, personal representatives, successors in interest, and assigns, as a part of the consideration hereof, does hereby covenant and agree [in the case of deeds and leases add "as a covenant running with the land"] that:
  - (i.) In the event facilities are constructed, maintained, or otherwise operated on the property described in this (deed, license, lease, permit, etc.) for a purpose for which a U.S. Department of Transportation activity, facility, or program is extended or for another purpose involving the provision of similar services or benefits, the (grantee, licensee, lessee, permittee, etc.) will maintain and operate such facilities and services in compliance with all requirements imposed by the Acts and Regulations (as may be amended) such that no person on the grounds of race, color, or national origin, will be excluded from participation in, denied the benefits of, or be otherwise subjected to discrimination in the use of said facilities.
2. With respect to licenses, leases, permits, etc., in the event of breach of any of the above Nondiscrimination covenants, the NCDOT will have the right to terminate the (lease, license, permit, etc.) and to enter, re-enter, and repossess said lands and facilities thereon, and hold the same as if the (lease, license, permit, etc.) had never been made or issued. \*
3. With respect to a deed, in the event of breach of any of the above Nondiscrimination covenants, the NCDOT will have the right to enter or re-enter the lands and facilities thereon, and the above described lands and facilities will there upon revert to and vest in and become the absolute property of the NCDOT and its assigns. \*

(\*Reverter clause and related language to be used only when it is determined that such a clause is necessary to make clear the purpose of Title VI.)

(c) Clauses for Construction/Use/Access to Real Property Acquired Under the Activity, Facility or Program (1050.2A, Appendix D)

The following clauses will be included in deeds, licenses, permits, or similar instruments/ agreements entered into by the North Carolina Department of Transportation (NCDOT) pursuant to the provisions of Assurance 7(b):

1. The (grantee, licensee, permittee, etc., as appropriate) for himself/herself, his/her heirs, personal representatives, successors in interest, and assigns, as a part of the consideration hereof, does hereby covenant and agree (in the case of deeds and leases add, "as a covenant running with the land") that (1) no person on the ground of race, color, or national origin, will be excluded from participation in, denied the benefits of, or be otherwise subjected to discrimination in the use of said facilities, (2) that in the construction of any improvements on, over, or under such land, and the furnishing of services thereon, no person on the ground of race, color, or national origin, will be excluded from participation in, denied the benefits of, or otherwise be subjected to discrimination, (3) that the (grantee, licensee, lessee, permittee, etc.) will use the premises in compliance with all other requirements imposed by or pursuant to the Acts and Regulations, as amended, set forth in this Assurance.
2. With respect to (licenses, leases, permits, etc.), in the event of breach of any of the above Non-discrimination covenants, the NCDOT will have the right to terminate the (license, permit, etc., as appropriate) and to enter or re-enter and repossess said land and the facilities thereon, and hold the same as if said (license, permit, etc., as appropriate) had never been made or issued. \*
3. With respect to deeds, in the event of breach of any of the above Nondiscrimination covenants, the NCDOT will there upon revert to and vest in and become the absolute property of the NCDOT and its assigns. \*

(\*Reverter clause and related language to be used only when it is determined that such a clause is necessary to make clear the purpose of Title VI.)

**STANDARD SPECIAL PROVISION****ON-THE-JOB TRAINING**

(10-16-07) (Rev. 4-21-15)

Z-10

**Description**

The North Carolina Department of Transportation will administer a custom version of the Federal On-the-Job Training (OJT) Program, commonly referred to as the Alternate OJT Program. All contractors (existing and newcomers) will be automatically placed in the Alternate Program. Standard OJT requirements typically associated with individual projects will no longer be applied at the project level. Instead, these requirements will be applicable on an annual basis for each contractor administered by the OJT Program Manager.

On the Job Training shall meet the requirements of 23 CFR 230.107 (b), 23 USC – Section 140, this provision and the On-the-Job Training Program Manual.

The Alternate OJT Program will allow a contractor to train employees on Federal, State and privately funded projects located in North Carolina. However, priority shall be given to training employees on NCDOT Federal-Aid funded projects.

**Minorities and Women**

Developing, training and upgrading of minorities and women toward journeyman level status is a primary objective of this special training provision. Accordingly, the Contractor shall make every effort to enroll minority and women as trainees to the extent that such persons are available within a reasonable area of recruitment. This training commitment is not intended, and shall not be used, to discriminate against any applicant for training, whether a member of a minority group or not.

**Assigning Training Goals**

The Department, through the OJT Program Manager, will assign training goals for a calendar year based on the contractors' past three years' activity and the contractors' anticipated upcoming year's activity with the Department. At the beginning of each year, all contractors eligible will be contacted by the Department to determine the number of trainees that will be assigned for the upcoming calendar year. At that time the Contractor shall enter into an agreement with the Department to provide a self-imposed on-the-job training program for the calendar year. This agreement will include a specific number of annual training goals agreed to by both parties. The number of training assignments may range from 1 to 15 per contractor per calendar year. The Contractor shall sign an agreement to fulfill their annual goal for the year.\

**Training Classifications**

The Contractor shall provide on-the-job training aimed at developing full journeyman level workers in the construction craft/operator positions. Preference shall be given to providing training in the following skilled work classifications:

Equipment Operators	Office Engineers
Truck Drivers	Estimators
Carpenters	Iron / Reinforcing Steel Workers
Concrete Finishers	Mechanics
Pipe Layers	Welders

The Department has established common training classifications and their respective training requirements that may be used by the contractors. However, the classifications established are not all-inclusive. Where the training is oriented toward construction applications, training will be allowed in lower-level management positions such as office engineers and estimators. Contractors shall submit new classifications for specific job functions that their employees are performing. The Department will review and recommend for acceptance to FHWA the new classifications proposed by contractors, if applicable. New classifications shall meet the following requirements:

Proposed training classifications are reasonable and realistic based on the job skill classification needs, and

The number of training hours specified in the training classification is consistent with common practices and provides enough time for the trainee to obtain journeyman level status.

The Contractor may allow trainees to be trained by a subcontractor provided that the Contractor retains primary responsibility for meeting the training and this provision is made applicable to the subcontract. However, only the Contractor will receive credit towards the annual goal for the trainee.

Where feasible, 25 percent of apprentices or trainees in each occupation shall be in their first year of apprenticeship or training. The number of trainees shall be distributed among the work classifications on the basis of the contractor's needs and the availability of journeymen in the various classifications within a reasonable area of recruitment.

No employee shall be employed as a trainee in any classification in which they have successfully completed a training course leading to journeyman level status or in which they have been employed as a journeyman.

**Records and Reports**

The Contractor shall maintain enrollment, monthly and completion reports documenting company compliance under these contract documents. These documents and any other information as requested shall be submitted to the OJT Program Manager.



Upon completion and graduation of the program, the Contractor shall provide each trainee with a certification Certificate showing the type and length of training satisfactorily completed.

**Trainee Interviews**

All trainees enrolled in the program will receive an initial and Trainee/Post graduate interview conducted by the OJT program staff.

**Trainee Wages**

Contractors shall compensate trainees on a graduating pay scale based upon a percentage of the prevailing minimum journeyman wages (Davis-Bacon Act). Minimum pay shall be as follows:

60 percent	of the journeyman wage for the first half of the training period
75 percent	of the journeyman wage for the third quarter of the training period
90 percent	of the journeyman wage for the last quarter of the training period

In no instance shall a trainee be paid less than the local minimum wage. The Contractor shall adhere to the minimum hourly wage rate that will satisfy both the NC Department of Labor (NCDOL) and the Department.

**Achieving or Failing to Meet Training Goals**

The Contractor will be credited for each trainee employed by him on the contract work who is currently enrolled or becomes enrolled in an approved program and who receives training for at least 50 percent of the specific program requirement. Trainees will be allowed to be transferred between projects if required by the Contractor's scheduled workload to meet training goals.

If a contractor fails to attain their training assignments for the calendar year, they may be taken off the NCDOT's Bidders List.

**Measurement and Payment**

No compensation will be made for providing required training in accordance with these contract documents.

U-3422A

# GT-1

Cumberland County

## PROJECT SPECIAL PROVISIONS

### GEOTECHNICAL

STANDARD SHORING - (01/16/2024)

GT-1.1 - GT-1.4

DocuSigned by:

*Geotechnical Engineering Unit*  
09/24/2024

E06538624A11498...

**STANDARD SHORING:****(1-16-24)****Description**

Standard shoring includes standard temporary shoring and standard temporary mechanically stabilized earth (MSE) walls. At the Contractor's option, use standard shoring as noted in the plans or as directed. When using standard shoring, a temporary shoring design submittal is not required. Construct standard shoring based on actual elevations and shoring dimensions in accordance with the contract and Geotechnical Standard Detail No. 1801.01 or 1801.02.

Define "standard temporary shoring" as cantilever shoring that meets the standard temporary shoring detail (Geotechnical Standard Detail No. 1801.01). Define "standard temporary wall" as a temporary MSE wall with geotextile or geogrid reinforcement that meets the standard temporary wall detail (Geotechnical Standard Detail No. 1801.02). Define "standard temporary geotextile wall" as a standard temporary wall with geotextile reinforcement and "standard temporary geogrid wall" as a standard temporary wall with geogrid reinforcement.

Provide positive protection for standard shoring at locations shown in the plans and as directed. See *Temporary Shoring* provision for positive protection types and definitions.

**Materials**

Refer to the *Standard Specifications*.

<b>Item</b>	<b>Section</b>
Concrete Barrier Materials	1170-2
Flowable Fill, Excavatable	1000-7
Geosynthetics	1056
Grout, Type 1	1003
Portland Cement Concrete, Class A	1000
Select Materials	1016
Steel Beam Guardrail Materials	862-2
Steel Sheet Piles and H-Piles	1084
Untreated Timber	1082-2
Welded Wire Reinforcement	1070-3

Provide Type 6 material certifications for shoring materials. Use Class IV select material for temporary guardrail. Use Class A concrete that meets Article 450-2 of the *Standard Specifications* or Type 1 grout for drilled-in piles.

Based on actual shoring height, positive protection, groundwater elevation, slope or surcharge case and traffic impact at each standard temporary shoring location, use sheet piles with the minimum required section modulus or H-piles with the sizes shown in Geotechnical Standard Detail No. 1801.01. Use untreated timber with a thickness of at least 3" and a bending stress of at least 1,000 psi for timber lagging.

**(A) Shoring Backfill**

Use Class II, Type 1, Class III, Class V or Class VI select material or material that meets AASHTO M 145 for soil classification A-2-4 with a maximum PI of 6 for shoring backfill except do not use the following:

- (1) A-2-4 soil for backfill around culverts,

- (2) A-2-4 soil in the reinforced zone of standard temporary walls with a back slope and
- (3) Class VI select material in the reinforced zone of standard temporary geotextile walls.

**(B) Standard Temporary Walls**

Use welded wire reinforcement for welded wire facing, struts and wires with the dimensions and minimum wire sizes shown in Geotechnical Standard Detail No. 1801.02. Provide Type 2 geotextile for separation and retention geotextiles. Do not use more than 4 different reinforcement strengths for each standard temporary wall.

(1) Geotextile Reinforcement

Provide Type 4a geotextile for geotextile reinforcement except for the ultimate tensile strength. Based on actual wall height, groundwater elevation, slope or surcharge case and shoring backfill to be used in the reinforced zone at each standard temporary geotextile wall location, provide geotextiles with ultimate tensile strengths as shown in Geotechnical Standard Detail No. 1801.02.

(2) Geogrid Reinforcement

Use geogrids for geogrid reinforcement with a roll width of at least 4 ft and an “approved” status code in accordance with the NCDOT Geosynthetic Reinforcement Evaluation Program. The list of approved geogrids is available from:

[connect.ncdot.gov/resources/Geological/Pages/Products.aspx](http://connect.ncdot.gov/resources/Geological/Pages/Products.aspx)

Based on actual wall height, groundwater or flood elevation, slope or surcharge case and shoring backfill to be used in the reinforced zone at each standard temporary geogrid wall location, provide geogrids for geogrid reinforcement with short-term design strengths as shown in Geotechnical Standard Detail No. 1801.02. Geogrids are approved for short-term design strengths (3-year design life) in the machine direction (MD) and cross-machine direction (CD) based on material type. Define material type from the website above for shoring backfill as follows:

Material Type	Shoring Backfill
Borrow	A-2-4 Soil
Fine Aggregate	Class II, Type 1 or Class III Select Material
Coarse Aggregate	Class V or VI Select Material

**Preconstruction Requirements**

**(A) Concrete Barrier**

Define “clear distance” behind concrete barrier as the horizontal distance between the barrier and edge of pavement. The minimum required clear distance for concrete barrier is shown in the plans. At the Contractor’s option or if the minimum required clear distance is not available, set concrete barrier next to and up against traffic side of standard shoring except for barrier above standard temporary walls. Concrete barrier with the minimum required clear distance is required above standard temporary walls.

**(B) Temporary Guardrail**

Define “clear distance” behind temporary guardrail as the horizontal distance between guardrail posts and standard shoring. At the Contractor’s option or if clear distance for standard temporary shoring is less than 4 ft, attach guardrail to traffic side of shoring as shown in the plans. Place ABC in clear distance and around guardrail posts instead of pavement. Do not use temporary guardrail above standard temporary walls.

**(C) Standard Shoring Selection Forms**

Before beginning standard shoring construction, survey existing ground elevations in the vicinity of standard shoring locations to determine actual shoring or wall heights (H). Submit a standard shoring selection form for each location at least 7 days before starting standard shoring construction. Standard shoring selection forms are available from: [connect.ncdot.gov/resources/Geological/Pages/Geotech\\_Forms\\_Details.aspx](http://connect.ncdot.gov/resources/Geological/Pages/Geotech_Forms_Details.aspx)

**Construction Methods**

Construct standard shoring in accordance with the *Temporary Shoring* provision.

**(A) Standard Temporary Shoring Installation**

Based on actual shoring height, positive protection, groundwater elevation, slope or surcharge case and traffic impact at each standard temporary shoring location, install piles with the minimum required embedment and extension for each shoring section in accordance with Geotechnical Standard Detail No. 1801.01. For concrete barrier above and next to standard temporary shoring and temporary guardrail above and attached to standard temporary shoring, use “surcharge case with traffic impact” in accordance with Geotechnical Standard Detail No. 1801.01. Otherwise, use “slope or surcharge case with no traffic impact” in accordance with Geotechnical Standard Detail No. 1801.01. If refusal is reached before driven piles attain the minimum required embedment, use drilled-in H-piles with timber lagging for standard temporary shoring.

**(B) Standard Temporary Walls Installation**

Based on actual wall height, groundwater elevation, slope or surcharge case, geotextile or geogrid reinforcement and shoring backfill in the reinforced zone at each standard temporary wall location, construct walls with the minimum required reinforcement length and number of reinforcement layers for each wall section in accordance with Geotechnical Standard Detail No. 1801.02. For standard temporary walls with pile foundations in the reinforced zone, drive piles through reinforcement after constructing temporary walls.

For standard temporary walls with interior angles less than 90°, wrap geosynthetics at acute corners as directed by the Engineer. Place geosynthetics as shown in Geotechnical Standard Detail No. 1801.02. Place separation geotextiles between shoring backfill and backfill, natural ground or culverts along the sides of the reinforced zone perpendicular to the wall face. For Class V or VI select material in the reinforced zone, place separation geotextiles between shoring backfill and backfill or natural ground on top of and at the back of the reinforced zone.

**Measurement and Payment**

Standard shoring will be measured and paid in accordance with the *Temporary Shoring* provision.



DocuSigned by:  
*Scott A. Hidden*  
F760CAEB96FC4D3...  
09/24/2024

# TC-1

U-3422A

Cumberland County

## WORK ZONE TRAFFIC CONTROL Project Special Provisions Table of Contents

Special Provision	Page
ADA Compliant Pedestrian Traffic Control Devices	TC-2

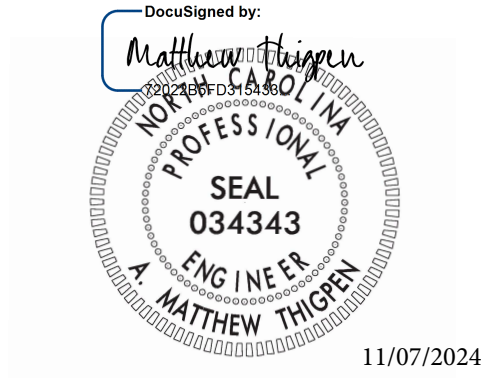

# TC-2

U-3422A

Cumberland County

**ADA COMPLIANT PEDESTRIAN TRAFFIC CONTROL DEVICES:**

(10/31/2017) (Rev. 6/3/2022)

**Description**

Furnish, install, and maintain all ADA compliant pedestrian traffic control devices for existing pedestrian facilities that are disrupted, closed, or relocated by planned work activities.

The ADA compliant pedestrian traffic control devices used to either close, redirect, divert or detour pedestrian traffic are Pedestrian Channelizing Devices, Audible Warning Devices and Temporary Curb Ramps.

**Construction Methods**

The ADA compliant pedestrian traffic control devices involved in the closing or redirecting of pedestrians as designated on the Transportation Management Plan (TMP) shall be manufactured and assembled in accordance with the requirements of the Americans with Disabilities Act (ADA) and be on the NCDOT approved products list.

Pedestrian Channelizing Devices shall be manufactured and assembled to be connected as to eliminate any gaps that allow pedestrians to stray from the channelizing path. Any Pedestrian Channelizing Devices used to close or block a pedestrian facility shall have a “SIDEWALK CLOSED” sign affixed to it and any audible warning devices, if designated on the TMP.

**Measurement and Payment**

*Pedestrian Channelizing Devices* will be measured and paid as the maximum number of linear feet of *Pedestrian Channelizing Devices* furnished, acceptably placed, and in use at any one time during the life of the project.

No direct payment will be made for any sign affixed to a pedestrian channelizing device. Signs mounted to pedestrian channelizing devices will be considered incidental to the device.

Relocation, replacement, repair, maintenance, or disposal of *Pedestrian Channelizing Devices* will be incidental to the pay item.

Payment will be made under:

**Pay Item**

**Pay Unit**

Pedestrian Channelizing Devices

Linear Foot



PROJECT SPECIAL PROVISIONS  
Utility Construction

Digitally signed by  
Michael A Pollard  
Date: 2024.11.08  
16:29:42-05'00'



11/08/2024



5400 Glenwood Avenue, Suite 400

Raleigh, NC 27612

O: 919-325-3594

www.cdmsmith.com

Revise the 2024 Standard Specifications as follows:

DOCUMENT NOT  
CONSIDERED FINAL  
  
UNLESS ALL SIGNATURES  
COMPLETED

Where brand names and model numbers are specified in these Special Provisions or in the plans, the cited examples are used only to denote the quality standard of product desired and do not restrict bidders to a specific brand, make, or manufacturer. They are provided to set forth the general style, type, character, and quality of the product desired. Equivalent products will be acceptable.

## Contents

**DIVISION 8 INCIDENTALS.....4**

**Page 8-36, ARTICLE 858-3, CONSTRUCTION METHODS.....4**

**Page 8-36, ARTICLE 858-4, MEASUREMENT AND PAYMENT .....4**

**DIVISION 10 MATERIALS.....4**

**SECTION 1034-SANITARY SEWER PIPE AND FITTINGS .....4**

Page 10-65, ARTICLE 1034-1 CLAY PIPE.....4

Page 10-65, ARTICLE 1034-2 PLASTIC PIPE .....4

Page 10-66, ADD ARTICLE 1034-5 SLEEVES, COUPLINGS AND MISCELLANEOUS.....9

Page 10-66, ADD ARTICLE 1034-6 SADDLES AND LATERALS .....11

Page 10-66 ARTICLE 1036-1 GENERAL.....13

Page 10-66 ARTICLE 1036-3 COPPER PIPE .....13

Page 10-66 ARTICLE 1036-3 PLASTIC PIPE .....13

Page 10-67 ARTICLE 1036-4 STEEL PIPE.....14

Page 10-67 ARTICLE 1036-5 DUCTILE IRON PIPE AND FITTINGS.....15

Page 10-67, ARTICLE 1036-6 FIRE HYDRANTS.....17

Page 10-67, ARTICLE 1036-7 WATER VALVES .....18

Page 10-68, ARTICLE 1036-8 SLEEVES, COUPLINGS AND MISCELLANEOUS .....19

Page 10-68, ARTICLE 1036-9 SERVICE LINE VALVES AND FITTINGS .....20

Page 10-68, ADD ARTICLE 1036-11 IDENTIFICATION OF PLASTIC OR NON-METALLIC PIPES.....21

Page 10-68, ADD ARTICLE 1036-12 VALVES BOX .....21

**DIVISION 15-UTILITY CONSTRUCTION .....23**

Page 25-1 ARTICLE 1500-2 COOPERATION WITH THE UTILITY OWNER.....23

Page 15, ARTICLE 1500-3 UTILITY LOCATIONS AND CONTRACTOR’S RESPONSIBILITY .....24

Page 15-1, ARTICLE 1500-4 WEEKEND, NIGHT AND HOLIDAY WORK.....24

Page 15-1, ARTICLE 1500-5 RELATION OF WATER MAINS TO NON-POTABLE WATER LINES AND OTHER UTILITIES.....25

Page 15-2, ARTICLE 1500-7 SUBMITTALS AND RECORDS .....25

Page 15-2, ARTICLE 1500-8 LOCATING AND MARKING .....27

Page 15-2, ARTICLE 1500-9 PLACING PIPELINES INTO SERVICE.....27

**SECTION 1505-EXCAVATION, TRENCHING, PIPE LAYING AND BACKFILLING FOR UTILITIES .....31**

    Page 15-3, ARTICLE 1505-2 MATERIALS .....31

    Page 15-4, ARTICLE 1505-3 CONSTRUCTION METHODS.....31

    Page 15-5, ARTICLE 1505-5 CONCRETE ENCASEMENT OF UTILITY LINES .....34

    Page 15-5, ARTICLE 1505-6 MEASUREMENT AND PAYMENT .....34

    Page 15-5, ARTICLE 1510-S2 MATERIALS .....34

    Page 15-6 ARTICLE 1510-3 GENERAL.....35

    Page 15-7 ARTICLE 1515-2 MATERIALS .....39

    Page 15-8, ARTICLE 1515-3 CONSTRUCTION METHODS.....41

    Page 15-9, ARTICLE 1515-4 MEASUREMENT AND PAYMENT .....42

**SECTION 1520-SANITARY SEWER .....43**

    Page 15-10, ARTICLE 1520-2 MATERIALS .....43

    PAGE 15-11, ARTICLE 1520-3, CONSTRUCTION METHODS .....45

**1525-UTILITY MANHOLES .....53**

    Page 15-14, ARTICLE 1525-2 MATERIALS .....53

    Page 15-15 ARTICLE 1525-3 CONSTRUCTION METHODS.....55

**SECTION 1530 -ABANDON OR REMOVE UTILITIES .....59**

    Page 15-16, ARTICLE 1530-3 CONSTRUCTION METHODS.....59

    Page 15-17, ARTICLE 1530-4 MEASUREMENT AND PAYMENT.....59

**SECTION 1540-ENCASEMENT .....59**

    Page 15-18, ARTICLE 1540-2 MATERIALS .....59

    Page 15-18, ARTICLE 1540-3 CONSTRUCTION METHODS .....61

**SECTION 1550-TRENCHLESS INSTALLATION OF UTILITIES .....61**

    Page 15-20, ARTICLE 1550-3 CONSTRUCTION METHODS .....61

**Page 15-20, ARTICLE 1550-4 MEASUREMENT AND PAYMENT.....61**

**DIVISION 8 INCIDENTALS**

**SECTION 858-ADJUSTMENT OF CATCH BASINS, MANHOLES, DROP INLETS, METER BOXES AND VALVE BOXES**

**Page 8-35, ARTICLE 858-2, MATERIALS**

Add the following after line 34:

If a meter box or valve box is damaged during adjustment provide a new meter box or valve box that meets PWC standards.

Item	Section
Manholes	Special Provisions 1525-2

**Page 8-36, ARTICLE 858-3, CONSTRUCTION METHODS**

Add the following provisions to the second paragraph:

Adjustment of Valve Boxes:

The top section of the valve box shall be raised or lowered as required to meet the final grade. If the height of the final grade exceeds the length of the existing top section, remove the existing valve box, and install a new one at final grade. New valve boxes shall be installed in accordance with PWC’s standards.

**DIVISION 10 MATERIALS**

**SECTION 1034-SANITARY SEWER PIPE AND FITTINGS**

**Page 10-65, ARTICLE 1034-1 CLAY PIPE**

Add the following paragraph:

Clay pipe shall not be used for sewer pipe unless approved in writing by PWC. All sewer pipes shall be PVC or Ductile Iron as specified herein.

**Page 10-65, ARTICLE 1034-2 PLASTIC PIPE**

Add the following sentences:

All materials for the sewer system shall be in accordance with these Special Provisions.

**Page 10-65, Sub-article 1034-2 (A) PVC Gravity Flow Sewer**

Replace the paragraph with the following:

PVC sewer pipe shall only be used if approved by PWC. PVC sewer pipe and fittings 4- through 15-inches shall be in accordance with ASTM D-3034 with a standard dimension ratio (SDR) of 26 for sewer mains and laterals. Larger diameter pipe (18 inches and larger) shall be in accordance with ASTM F-679 with a (SDR) of 26. Both pipe and fittings shall be made of PVC plastic having a cell classification of 12454 as specified in ASTM D-1784.

Pipe joining shall be push on elastomeric gasket joints only and the joints shall be manufactured and assembled in accordance with ASTM D-3212. Elastomeric seals shall meet the requirements of ASTM F-477. The pipe shall be furnished with integral bells and with gaskets that are permanently installed at the factory and in accordance with ASTM D-3212 and contain a steel reinforcing ring. PVC sewer pipe shall be made by continuous extrusion of prime green unplasticized PVC and contain identification markings as required by the applicable ASTM standard.

The use of restrained joint ductile iron pipe C900 PVC (DR 18) shall be used for all gravity sewer main or lateral installations (4- through 24-inches) within encasements to a point a minimum of 10 feet outside the casing on each side. The restraint system shall provide uniform circumferential contact thereby eliminating any concerns over point loading. The use of PVC within encasements shall be evaluated on a case by case basis..

**Ductile Iron Sanitary Sewer Push-on Fittings:** Ductile iron sewer fittings on PVC mains shall be deep-bell, gasketed joint, and air test rated. Gasket grooves shall be machined in the factory. Material shall be ductile iron, in accordance with ASTM A536, Grade 65-45-12 and ASTM F1336. Wall thickness shall meet the requirements of AWWA C153. Gaskets shall have a minimum cross-sectional area of 0.20 square-inches and conform to ASTM F477. All ductile iron fittings shall be lined with two (2) coats of ceramic epoxy to produce a total minimum dry film thickness of 40 mils on its' interior. All ductile iron fittings on PVC pipe shall provide a flow line that will match the same flow line as the PVC pipe materials.

**Mechanical Joint Sanitary Sewer Fittings:** Joints shall be installed in accordance with AWWA C-600 and shall conform to AWWA Standard C-111. Mechanical joints shall be of the stuffing box type and shall conform to ANSI A21.11 for 4-inch pipes and larger. Fittings and specials shall be ductile iron and shall be manufactured in accordance with AWWA Standard C-110 (ANSI A21.11). Compact fittings shall be ductile iron in accordance with ANSI A21.53 (AWWA C-153) for 4- through 24-inch sizes only. Note: mechanical joint wyes are not included in the AWWA C-153 specification. Pressure rating shall be not less than 200 psi unless otherwise specified. All ductile iron fittings shall be lined with two (2) coats of ceramic epoxy to produce a total minimum dry film thickness of 40 mils on its' interior. Mechanical joint fittings shall be utilized on ductile iron mains and ductile iron laterals. Mechanical joint fittings shall not be utilized on PVC mains, unless otherwise approved by PWC.

PVC Fittings: PVC fittings shall be manufactured in accordance with ASTM D-3034, F-1336, and F-679. Molded fittings shall be utilized in sizes from 4-to-8-inches (or larger, if available). Fabricated fittings shall only be used with prior approval from PWC. Fabricated fittings are defined as those fittings that are made from pipe or a combination of pipe and molded components. All PVC fittings shall contain identification markings as required by the applicable ASTM standard. All PVC fittings shall be gasketed joint, except as indicated for interior drop structures. PVC fittings shall be as manufactured by GPK Products, Inc., Plasti-Trends, the Harrington Corporation (Harco), or approved equal.

**Page 10-65, Sub-article 1034-2 (B) PVC Force Main Sewer Pipe**

Replace with the following:

All force main PVC pipe shall be green in color.

Two-inch PVC pipe shall be manufactured using Grade 1 PVC compound material as defined in ASTM D-1784 and shall be SDR21, pressure class 200 in accordance with ASTM D 2241 Fittings for 2-inch PVC shall be solvent welded Schedule 80 PVC. The pipe shall be plainly marked with the manufacturer's name, size, material (PVC) type and grade or compound, NSF seal, pressure rating and reference to appropriate product standards.

All PVC pipe 4- through 12-inches shall be manufactured using virgin compounds as defined in ASTM D-1784, with a 4000 psi HDB rating and designated as PVC 1120 to be in strict accordance with AWWA C900. The pipe shall be Class 150 and conform to the thickness requirements of DR18. The pipe shall be manufactured to withstand 755 psi quick burst pressure tested in accordance with ASTM D-1599 and withstand 500 psi for a minimum of 1,000 hours tested in accordance with ASTM D-1598. The pipe joints shall be of the integral bell type with rubber gaskets conforming to the requirements of ASTM D-3139 or ASTM F-477.

**Couplings:**

Couplings for 2 in. pipe shall be compression, twin gasket type in accordance with ASTM D-3139 for push-on joints and ASTM F-477 for elastomeric seals (gaskets).

PVC fittings are not acceptable for mains other than 2-inch. Fittings and specials for 4-inch mains and larger shall be mechanical joint ductile iron and shall be lined with two (2) coats of ceramic epoxy to produce a total minimum dry film thickness of 40 mils on its' interior. Fittings and specials for 4-inch mains and larger shall be mechanical joint ductile iron and shall be lined with two (2) coats of ceramic epoxy to produce a total minimum dry film thickness of 40 mils on its' interior. All fittings shall be adequately supported on a firm trench foundation.

Thrust blocking shall be utilized at all applicable fittings. Fittings requiring thrust blocking shall be full bodied mechanical joint. Compact mechanical joint fittings shall not be allowed where thrust blocking is required

Mechanical restraining systems shall not be used on PVC pipe.

**Page 10-65, Sub-article 1034-2 (C) Polyethylene (PE) Pipe Force Main Sewer Pipe**

Replace with the following:

PE pipe shall not be used for force main sewer pipe unless approved in writing by PWC. All sewer pipes shall be PVC or Ductile Iron as specified herein.

**Page 10-65, Add Sub-article 1034-2 (D) High Density Polyethylene (HDPE) Pipe Force Main Sewer Pipe**

Add the following:

The diameter and wall thickness of all high-density polyethylene (HDPE) pipe and fittings shall comply with the appropriate ASTM Specification and the class of pipe designated on the Drawings. HDPE pipe shall not be used unless approved in writing by PWC.

High Density Polyethylene (HDPE) pipe and fittings shall meet the requirements of ASTM F714 and AWWA C906.

HDPE must meet the following minimum Dimension Ratio:

Diameter (inch)	Min Dimension Ratio
4-12	DR13.5
12-48	DR11

The pipes have nominal dimensions shown on Drawings and conform to dimension requirements of the Ductile Iron Pipe Size (DIPS) Sizing System.

Polyethylene pipes to meet requirements of ASTM F714 and AWWA C906.

Pipe to be furnished in standard laying lengths not exceeding 50-feet.

**Page 10-65, ARTICLE 1034-3 CONCRETE SEWER PIPE**

Add the following sentences:

Concrete pipe shall not be used for sewer pipe unless approved in writing by PWC. All sewer pipes shall be PVC or Ductile Iron as specified herein.

**Page 10-65, ARTICLE 1034-4 DUCTILE IRON SEWER PIPE**

**Page 10-65, Sub-article 1034-4 (A) Gravity Flow Sewer Pipe**

Add the following paragraphs:

All ductile iron pipe and fittings shall be in strict accordance with ANSI A21.51 and AWWA C151, Class 50 or Class 51, as applicable, in every aspect. The working pressure shall be a minimum of 200 psi. Pipe shall be furnished in 18 or 20-foot lengths. All pipe joints used in open trench construction shall be furnished with "push-on" joints, unless otherwise specified. All joints and fittings shall be in accordance with ANSI A21.11 and AWWA C111. All ductile iron interior surfaces shall be lined with two (2) coats of ceramic epoxy to produce a total minimum dry film thickness of 40 mils. The exterior pipe surfaces shall be protected with asphaltic coating as specified in AWWA C151 and C110.

For aerial crossings which are 4- through 12-inches in diameter, manufactured restrained joint ductile iron pipe Class 53, or Class 53 flanged ductile iron pipe shall be used in accordance with the applicable PWC detail for aerial crossings. Mega-lugs, field-lock, and gripper rings are not an allowable means of restraint for aerial crossings. For aerial crossings larger than 12 inches, or as noted specifically on the plans, flange joint ductile iron pipe, Class 53, shall be used in accordance with the standard PWC details. The location of flanges shall be specifically designed for each application. The flange pipe shall be in accordance with ANSI/AWWA C115/A21.15. Threads for threaded flange pipe shall be in accordance with ANSI B2.1, shop fabricated as outlined by AWWA C115 with serrated faces furnished on the pipe, completely factory installed. Welding of flanges to the body of the pipe will not be acceptable. Ductile iron fittings and flanges shall be in accordance with ANSI/AWWA C110/A21.10 with a minimum working pressure of 250 psi. Gaskets shall be full faced SBR rubber per ANSI/AWWA C-111/A21.11 with a minimum 1/8-inch thickness. Ductile iron pipe shall be lined with two (2) coats of ceramic epoxy to produce a total minimum dry film thickness of 40 mils.

Mechanical Joint Fittings: Joints shall be installed in accordance with AWWA C600 and shall conform to AWWA C111. Mechanical joints shall be of the stuffing box type and shall conform to ANSI A21.11 for 4-inch pipes and larger. Fittings and specials shall be ductile iron and shall be manufactured in accordance with AWWA C110 (ANSI A21.11 ). Compact fittings shall be ductile iron in accordance with ANSI A21.53 (AWWA C153) for 4- through 24-inch sizes only. Note: mechanical joint wyes are not included in the AWWA C153 specification. Pressure rating shall be not less than 200 psi unless otherwise specified. All ductile iron fittings shall be lined with two (2) coats of ceramic epoxy to produce a total minimum dry film thickness of 40 mils. The exterior fitting surfaces shall be protected with asphaltic coating as specified in AWWA C151 and C110.

Mechanical joint fittings shall be used on ductile iron mains and ductile iron laterals. Mechanical joint fittings shall not be used on PVC mains, unless otherwise approved by PWC.

**The interior of pipe and fittings shall be lined with two (2) coats of ceramic epoxy to produce a minimum dry film thickness of 40 mils. The exterior fitting surfaces shall be protected with asphaltic coating as specified in AWWA C151 and C110.**

#### **Page 10-65, Sub-article 1034-4 (B) Force Main Sewer Pipe and Fittings**

Add the following sentences:



Four-inch ductile iron pipe shall be Class 51. Joints shall be mechanical joint or push on joint as specified and installed in accordance with AWWA C600 and shall conform to AWWA C111. All ductile iron pipe and fittings (6 inches and above) shall be in strict accordance with ANSI/AWWA C150/A21.50 and ANSI/AWWA C151/A21.51, Class 50, in every respect. Push on joints, rubber gaskets and lubricant shall conform to ANSI A2 1.11. Fittings and specials shall be mechanical joint ductile iron and shall be manufactured in accordance with AWWA C111 (ANSI A21.11). Mechanical joints shall be of the stuffing box type and shall conform to ANSI A21.11 for 4- through 12-inch pipe. All ductile iron pipe and fittings shall be lined with two (2) coats of ceramic epoxy to produce a total minimum dry film thickness of 40 mils. The exterior pipe and fitting surfaces shall be protected with asphaltic coating as specified in AWWA C151 and C110.

Compact fittings shall be manufactured or mechanically restrained, ductile iron in accordance with ANSI A21.53 (AWWA C153) for 4- through 12-inch sizes only. Where thrust blocking is used, fittings shall be full body ductile iron in accordance with ANSI A21.53 (AWWA C110). Pressure rating shall not be less than 200 psi unless otherwise specified. All ductile iron interior surfaces shall be lined with two (2) coats of ceramic epoxy to produce a total minimum dry film thickness of 40 mils. The exterior pipe surfaces shall be protected with asphaltic coating as specified in AWWA C151 and C110.

All pipe joints within an encasement shall be furnished with manufactured restrained joints, and as specified in the standard Public Works Commission detail for encasements.

For aerial crossings which are 4- through 12-inches in diameter, manufactured restrained joint ductile iron pipe Class 53, or Class 53 flanged ductile iron pipe shall be used in accordance with the detail on the drawings for aerial crossings. Iron mechanical joint restraint retaining glands are not an allowable means of restraint for aerial crossings. For aerial crossings larger than 12 inches, or as noted specifically on the plans, flange joint ductile iron pipe, Class 53, shall be used in accordance with the drawings. The location of flanges shall be specifically designed for each application. The flange pipe shall be in accordance with AWWA C115. Threads for threaded flange pipe shall be in accordance with ANSI B2.1, shop fabricated as outlined by AWWA C115 with serrated faces furnished on the pipe, completely factory installed. Welding of flanges to the body of the pipe will not be acceptable. Ductile iron fittings and flanges shall be in accordance with ANSI/AWWA C110/A21.10 with a minimum working pressure of 250 psi. Gaskets shall be full faced SBR rubber per ANSI/AWWA C111/A21.11 with a minimum 1/8-inch thickness. Linings and coatings shall be as outlined for ductile iron pipe.

**Page 10-66, ADD ARTICLE 1034-5 SLEEVES, COUPLINGS AND MISCELLANEOUS**

Add the following provisions for sleeves, couplings and miscellaneous:

**Page 10-66, Sub-article 1034-5 (A)- Transition Fittings**

**Ductile Iron Pipe Size x SDR26 Transition Adapter**-All ductile-iron x PVC transition adapters shall be one (1) piece, bell x bell (gasket x gasket). Transition adapters shall range in size from 4- through 12-inches. Transition adapters for pipe larger than 12 inches shall be as specified herein. All transition adapters shall have a flow way tapered to allow a smooth transition between the

ductile iron and PVC. Transition adapters shall be either PVC or ductile iron, in accordance with the following:

**PVC** – All PVC transition fittings shall be made from DR 18 C900 pipe stock. The C900 pipe stock shall meet the requirements of AWWA C900/C905 and have a minimum cell classification of 12454 as defined in ASTM D1784. The wall thickness shall meet or exceed DR 18. PVC transition fittings shall have SBR gaskets in accordance with ASTM F477. All 4 inch through 12 -inch adapters shall be molded and shall have SBR rubber gaskets. Joints shall be 235 psi rated in accordance with ASTM D3139 for the C900(ductile iron) bell, and in accordance with ASTM D3212 for sewer (SDR 26) bell. Molded C900 bell depths shall comply with AWWA C907. Fabricated (4-inch, 10-inch, and 12-inch) bell depths and molded sewer (SDR26) bell depths shall be in accordance with ASTM F1336. Any transitions larger than 12 in. will not be allowed unless specially approved in writing by PWC.

**Ductile iron** – Ductile iron transition fittings four-inch through 12-inch shall be deep-bell, push-on joint, and air test rated. The ductile-iron material shall comply with ASTM A536, Grade 65-45-12 or 80-55-06. The bell depth shall be in accordance with ASTM F1336. Gaskets shall be of SBR rubber, in accordance with ASTM F477. Transition gaskets are not allowed. All ductile-iron transition fittings shall be lined with two (2) coats of ceramic epoxy to produce a total minimum dry film thickness of 40 mils. Any transitions larger than 12 in. will not be allowed unless specially approved in writing by PWC.

#### **Page 10-66, Sub-article 1034-5 (B)- Pipe to Manhole Connector (Boot)**

The connector assembly shall be the sole element to provide a watertight seal of the pipe to the manhole or other structure. The connector shall consist of a rubber gasket, an internal compression sleeve, and one or more external take-up clamps. The connector shall consist of natural or synthetic rubber and Series 300 non-magnetic stainless-steel. No plastic components shall be allowed.

The rubber gasket shall be constructed of synthetic or natural rubber and shall meet or exceed the requirements of ASTM C923. The connector shall have a minimum tensile strength of 1,600 psi. The minimum cross-sectional thickness shall be 0.275 inches.

The internal expansion sleeve shall be comprised of Series 300 non-magnetic stainless-steel. No welds shall be used in its construction.

Installation of the connector shall be performed utilizing a calibrated installation tool furnished by the connector manufacturer. Installation shall require no re-tightening after the initial installation. Installation shall be done in accordance with the manufacturer's instructions.

The external compression take-up clamps shall be Series 300 non-magnetic stainless-steel. No welds shall be use in its construction. The clamps shall be installed using a torque-setting wrench furnished by the connector manufacturer. Installation shall be done in accordance with the manufacturer's instructions.

The Contractor shall utilize the proper size connector in accordance with the connector manufacturer's recommendations.

The finished connection shall provide a sealing to a minimum of 13 psi and shall accommodate a minimum pipe deflection of 7 degrees without the loss of seal.

The pipe to manhole connector shall be PSX: Direct Drive as manufactured by Press-Seal or approved equal.

**Page 10-66, ADD ARTICLE 1034-6 SADDLES, CONNECTIONS AND LATERALS**

Add the following provisions for saddles and laterals

**Page 10-66, Sub-article 1034-6 (A) Saddles**

Sewer service saddles may be used for sewer lateral installations. All sewer service saddles shall be ductile iron with stainless-steel straps, bolts, nuts, and washers. The nuts shall be coated to prevent galling. The saddle body shall be ductile iron, in accordance with ASTM A536, Grade 65-45-12. The gasket material shall be SBR, in accordance with ASTM D2000. Saddles for PVC or DI laterals shall have an alignment flange. All stainless-steel straps shall be pre-formed at the factory, to the specified outside diameters of the pipe. Saddles shall be as manufactured by Geneco, or an approved equal.

**Page 10-66, Sub-article 1034-5 (B) Sewer Laterals**

Use fittings meeting the requirements of the following provisions and table:

Mechanical joint fittings shall be used on ductile iron mains and ductile iron laterals. Mechanical joint fittings shall not be used on PVC mains, unless otherwise approved by PWC.

The interior of ductile iron pipe and fittings shall be lined with two (2) coats of ceramic epoxy to produce a minimum dry film thickness of 40 mils.

Ductile iron laterals – For ductile iron mains, using mechanical joint fittings or an approved saddle with an alignment flange (Geneco or approved equal). For PVC mains, use an approved saddle with an alignment flange (Geneco or approved equal) or ductile iron fittings as specified above.

PVC laterals – use a saddle with an alignment flange on PVC or ductile iron mains; use a mechanical joint tee with SDR 35 transition gaskets on ductile iron mains; or use PVC fittings as specified within these Special Provisions on PVC sewer mains.

The following table summarizes the materials to be used for sewer main to lateral connections:

	PVC Main	DI Main
DI Lateral	DI fitting or approved saddle	MJ fitting or approved saddle

PVC Lateral	PVC fitting or approved saddle	MJ fitting with transition gasket or approved saddle
-------------	--------------------------------	--

Sewer laterals shall be as specified herein and as indicated on the drawings.

**Page 10-66, Sub-article 1034-5 (D) Special Coatings**

Add material specifications for ceramic epoxy as follows:

Were ceramic epoxy linings are required, provide lining meeting the requirements contained within these special provisions.

The lining material shall be an amine cured novalac epoxy containing at least 20% by volume of ceramic quarts pigment.

The epoxy material shall meet the following minimum performance requirements:

Permeability Rating: 0.00 perms when tested according to ASTM E-96 Procedure A with a test duration of 30 days.

ASTM 6-95 Cathodic Disbandment: 1.5 volts at 77°F.

ASTM B-117 Salt Spray: 0.00 undercutting after one year.

Immersion Testing ASTM D-714	Duration
20% Sulfuric Acid	1 Year
25% Sodium Hydroxide at 140°F	1 Year
160°F Distilled Water	1 Year
120°F Tap Water	1 Year

The above requirements shall be verified and tested by an approved testing laboratory. Copies of the laboratory test showing that the lining conforms to the specifications shall be furnished to the Public Works Commission, certified by the Supplier.

**SECTION 1036-WATER PIPE AND FITTINGS****Page 10-66 ARTICLE 1036-1 GENERAL**

Add the following sentences:

Unless otherwise designated on Drawings or permitted by PWC, all water mains 4 inches and larger in diameter shall be ductile iron as specified herein. Two-inch water mains shall be SDR 21 PVC conforming to specifications contained herein.

**Page 10-66 ARTICLE 1036-3 COPPER PIPE**

Replace second paragraph with the following:

For buried services, use copper water pipe and tube conforming to ASTM B88 soft annealed Type K. The minimum pressure rating for the copper water pipe shall be 655 psi. Use cast brass compression type fittings manufactured for use with copper water pipe and conforming to ANSI/AWWA C800 and local plumbing codes. All brass fittings shall have a 300 psi minimum pressure rating. All services installed in new construction shall be one continuous run of pipe with no splices from the corporation stop to the meter.

**Page 10-66 ARTICLE 1036-3 PLASTIC PIPE****(A) PVC Pipe****Page 10-66, Sub-article 1036-3 (A) (1) Pressure Rated Pipe**

Replace with the following:

Pressure rated pipe shall not be used as water pipe.

**Page 10-66, Sub-article 1036-3 (A) (2) Pressure Class Pipe**

Replace with the following:

Two-inch (2") PVC pipe shall be manufactured using Grade 1 PVC compound material as defined in ASTM D-1784 and shall be SDR-21, pressure class 200 in accordance with ASTM D 2241. Fittings for 2" PVC pipe shall be solvent weld Schedule 80 PVC. Brass FIP x pack joint for PVC fittings shall be used to transition from PVC to brass. The pipe shall be plainly marked with the manufacturer's name, size, material (PVC) type and grade or compound, NSF seal, pressure rating and reference to appropriate product standards.

All PVC pipe (4- through 12-inch-diameter) shall be manufactured using virgin compounds as defined in ASTM D-1784, with a 4000 psi HDB rating and designated as PVC 1120 to be in strict accordance with AWWA C900. The pipe shall be Class 150 and conform to the thickness requirements of DR18. The pipe shall be manufactured to withstand 755 psi quick burst pressure tested in accordance with ASTM D-1599 and withstand 500 psi for a minimum of 1,000 hours

tested in accordance with ASTM D-1598. The pipe joints shall be of the integral bell type with rubber gaskets and shall conform to the requirements of ASTM D 3139 or ASTM F-477.

Mechanical restraining systems (i.e., mega-lug, grip-ring) shall not be used on PVC pipe.

Fittings and specials shall be ductile iron, bell end in accordance with AWWA C110, 200 psi pressure rating unless otherwise shown or specified. Ductile iron fittings and specials shall be cement mortar lined (standard thickness) in accordance with ANSI A21.4.

PVC fittings are not acceptable for water mains 4 inches or greater. Fittings and specials shall be mechanical joint ductile iron, bell end in accordance with AWWA C-110, 150 psi pressure rating unless otherwise shown or specified.

Ductile iron fittings shall be cement mortar lined (standard thickness) and asphaltic seal coat in accordance with ANSI/AWWA C104/A21.4. All fittings shall have an outside asphaltic coating as specified in AWWA Standard C-151 and C-110, respectively.

All fittings shall be adequately supported on a firm trench foundation.

**Page 10-66, Sub-article 1036-3 (B) Polyethylene Pipe (PE)**

Add the following:

The diameter and wall thickness of all high-density polyethylene (HDPE) pipe and fittings shall comply with the appropriate ASTM Specification and the class of pipe designated on the Drawings. HDPE pipe shall not be used unless approved in writing by PWC.

High Density Polyethylene (HDPE) pipe and fittings shall meet the requirements of ASTM F714 and AWWA C906.

HDPE must meet the following minimum Dimension Ratio:

Diameter (inch)	Min Dimension Ratio
4-12	DR13.5
12-48	DR11

The pipes have nominal dimensions shown on Drawings and conform to dimension requirements of the Ductile Iron Pipe Size (DIPS) Sizing System. Diameter of HDPE shall be such that inside diameter is at least the size called out on the plans.

Polyethylene pipes to meet requirements of ASTM F714 and AWWA C906.

Pipe to be furnished in standard laying lengths not exceeding 50-feet.

**Page 10-67 ARTICLE 1036-4 STEEL PIPE**

Add the following sentence:

Steel pipe shall not be used without prior approval by PWC.

**Page 10-67 ARTICLE 1036-5 DUCTILE IRON PIPE AND FITTINGS**

Replace with the following Sub-Articles:

**Page 10-67, Sub-article 1036-5 (A) Pressure Class Pipe**

All ductile iron pipe shall be 4 inches and larger. All ductile iron pipe shall be designated as “Pressure Class,” unless otherwise specified. The pipe furnished shall have a minimum thickness calculated in accordance with ANSI A21.50 (AWWA C150), with a factor of safety of two (2); a working pressure of 150 psi to 350 psi, plus 100 psi water hammer allowance; and AASHTO H-20 live truck load with 2.5 feet of cover. In no case shall “Pressure Class” pipe’s nominal thickness be less than the following:

SIZE (In.)	PRESSURE CLASS	NOMINAL THICKNESS (In.)
4	350	0.25
6	350	0.25
8	350	0.25
10	350	0.26
12	350	0.28
16	250	0.30
24	250	0.37

**Page 10-66 Sub-Article 1036-5 (B) Thickness Class Pipe**

For aerial crossings and other specific situations designated within these specifications, or where indicated on the drawings, and/or by PWC, the ductile iron pipe shall be Thickness Class. The minimum thickness class for 4-inch water mains shall be Class 51. The minimum thickness class for pipe diameters 6 inches and larger shall be Class 50. All thickness class pipe shall be in accordance with ANSI A21.51 and AWWA C151, with a minimum working pressure of 200 psi.

For aerial crossings which are 4- through 12-inches in diameter, Class 53 manufactured restrained joint or Class 53 flanged ductile iron pipe shall be used in accordance with the standard PWC details. Mega-lugs, field-lock, and gripper rings are not allowable means of restraint for aerial

crossings. For aerial crossings larger than 12 inches or as noted specifically on the plans, flange joint ductile iron pipe, Class 53 shall be used in accordance with the drawings. The working pressure shall not be less than 200 psi.

Flanges shall be designed for each application specifically. The flange pipe shall be in accordance with ANSI/AWWA C115/A21.15. Threads for threaded flange pipe shall be in accordance with ANSI B2.1, shop fabricated as outlined by AWWA C115 with serrated faces furnished on the pipe, completely factory installed. Welding of flanges to the body of the pipe will not be acceptable.

Ductile iron fittings and flanges shall be in accordance with ANSI/AWWA C110/A21.10 with a minimum working pressure of 250 psi. Flange joint gaskets shall be full faced SBR rubber per ANSI/AWWA C111/A21.11 with a minimum 1/8-inch-thickness.

### **Page 10-66 Sub-Article 1036-5 (C) Joint Types**

Joints shall be mechanical joint, push on joint, or factory restrained joint, unless otherwise indicated, conforming to AWWA C600 and AWWA C111.

Mechanical joints shall be of the stuffing box type and shall conform to ANSI A21.11 for 4-inch pipe through 12-inch pipe. Push on joints, rubber gaskets, and lubricant shall conform to ANSI A21.11.

Factory restrained joint pipe shall be utilized for all pipe greater than 12 inches in diameter, unless otherwise approved by PWC. Factory restrained joint pipe shall be furnished for the locations shown on the approved Contract Drawings. The pipe, joints, and gaskets shall be in accordance with applicable ANSI/AWWA Standards as specified for ductile iron pipe. Factory restrained joints shall be rated for a working pressure of 350 psi for sizes up to 12 inches and 250 psi for larger sizes.

All factory restrained joint pipe shall have the restraints internal to the pipe (i.e., "boltless"). All restrained joint ductile iron pipe and fittings larger than 12-inches shall be as manufactured by U.S. Pipe's TR-Flex, Griffin Pipe Products SNAP-LOK, American Cast Iron Pipe Company's Flex-Ring Joint, or approved equal. The method of restraining the valves to the factory restrained ductile iron pipe shall be reviewed and approved by PWC on a case-by-case basis. The valves shall have the same working pressure as the pipe.

### **Page 10-66 Sub-Article 1036-5 (D) Fittings**

Fittings and specials shall be mechanical joint ductile iron and shall be manufactured in accordance with AWWA C110 (ANSI A21.11). Compact fittings shall be mechanically restrained, ductile iron in accordance with AWWA C153 (ANSI A21.53) for 4-inch through 12-inch sizes only. Where thrust blocking is used, fittings shall be full body mechanical joint ductile iron in accordance with ANSI A21.53 (AWWA C110). Pressure rating shall be not less than 200 psi unless otherwise specified.

Tangential welded on outlets (i.e., bosses) shall only be utilized on pipe 24 inches and larger, as approved by PWC. All bosses shall be factory welded; field fabrication is not allowed. The pipe



shall be in accordance with these specifications. Bosses shall be of the size and location indicated on the approved drawings.

The DI/HDPE mechanical joint adaptor shall consist of a molded or fabricated HDPE mechanical joint transition fitting, rubber gasket, a mechanical joint backup drive ring and mechanical joint tee bolts. Pipe stiffeners shall be employed to support the interior wall of the HDPE. The stiffeners shall support the pipe's end and control the "necking down" reaction to the pressure applied during normal installation. The pipe stiffeners shall be formed of 304 or 316 stainless-steel, with a wedged style design to fit the HDPE manufacturers published average inside diameter of the specific size and DR of the HDPE.

#### **Page 10-66, Sub-Article 1036-5 (E) Linings and Coatings**

All ductile iron pipe fittings and specials shall be lined with standard thickness cement mortar lining and asphaltic seal coat in accordance with ANSI A21.4 (AWWA C104). Pipe and fittings shall have an outside asphaltic coating as specified in AWWA C151 and C110, respectively. The coating shall be strongly adherent to the pipe at all temperatures.

#### **Page 10-66, Sub-Article 1036-5 (F) Quality Assurance**

When requested by PWC, each joint of pipe and each fitting shall be inspected by an independent domestic testing laboratory, approved by PWC, and certification shall be supplied to PWC that all pipe and fittings meet project specifications. In addition, upon request, the Contractor shall furnish to PWC a six (6)-inch test section from each lot of water pipe as per AWWA C104 to be used for additional test of the pipe lining by PWC. Satisfactory results of this test must be obtained before acceptance of the pipe.

#### **Page 10-67, ARTICLE 1036-6 FIRE HYDRANTS**

Replace with the following:

All fire hydrants shall be dry barrel, traffic type and conform to the latest revision of AWWA C502 except as listed below or as otherwise directed by PWC. All working parts shall be bronzed. The size of the fire hydrants (designated by the nominal diameter of the valve opening) shall not be less than 4 1/2 inches. All hydrants shall be able to deliver 1,000 gallons per minute with a friction loss of not more than 5 pounds per square inch total head loss through the hydrant. Hydrants shall be of compression type (opening shall be of such design that when the barrel is broken off the hydrant valve will remain closed and reasonably tight against leakage). All hydrants shall be mechanical joint to accommodate the spigot end 6-inch Class 350, AWWA Standard, ductile iron pipe. Six (6)-inch bosses may be substituted for tees in pipe sizes exceeding 24 inches in diameter. The boss shall be welded to the bottom of the main to provide effective flushing of the system.

All hydrants shall be furnished with two 2 1/2 inch nozzles and one 4 1/2 inch pumper nozzle. Outlets shall have American National Standard fire hose coupling thread, in accordance with the City of Fayetteville standard, and shall be provided with nozzle caps securely chained to the body of the hydrant. The base of the hydrant shall have 2 cast lugs suitable for use in strapping the hydrant to the connecting pipe. The operating nut shall be pentagonal in shape, finished with a

slight taper to 1 1/2 inches from point to flat to conform to the standard wrench used by PWC. All hydrants shall open left or counterclockwise. Hydrants shall be suitable for working pressure of 150 pounds per square inch and test pressure of twice the working pressure. Fire hydrants shall be specific models manufactured by Mueller Company (Model Centurion 200), Clow Corporation (Medallion), American Darling (Model Mark 73-1) or approved equal. The interior of the hydrant shoe shall be coated with a 4-mil-thickness FDA approved epoxy coating. Paint hydrants with one coat of primer paint and two coats of an approved paint of the PWC's standard colors, as indicated in the standard detail. Apply the final coat after hydrant installation.

**Page 10-67, ARTICLE 1036-7 WATER VALVES**

**Page 10-67, Sub-article 1036-7 (A) Gate Valves**

Replace with the following:

All manually operated valves 4 inches and larger shall be ductile-iron body resilient wedge type gate valves conforming to ANSI/AWWA C509 for resilient seat-type valves or to ANSI/AWWA C515 for reduced-wall, resilient seat gate valves. Valve connections shall be as required for the piping in which they are installed and shall conform to ANSI/AWWA C111/A21.11. Gate valves shall have a design working water pressure of 250 psi.

All valves up to and including 36-inch-diameter shall have triple "O" ring stem seals. The design and machining of valves shall be such as to permit the replacement of the upper two (2) "O" rings without undue leakage while the valve is wide open and in service. The wedge shall be ductile iron encapsulated in nitrile rubber (4-to-12-inch) sizes and SBR rubber (14-to-24-inch) sizes. All internal and external surfaces of the valve body and bonnet shall have a fusion bonded epoxy coating complying with ANSI/AWWA C550 applied electrostatically prior to assembly, conforming to AWWA C550-90. Valves shall have a clear waterway equal to the full nominal diameter of the valve. All valves shall be tested for leakage and distortion in strict accordance with the latest revision of ANSI/AWWA C500.

For buried service, gate valves shall have non-rising stems, two (2)-inch-square operating nuts and shall open by turning counterclockwise. The operating nut shall have an arrow cut in the metal, indicating the direction of opening.

Gate valves installed in meter vaults shall have a wheel in lieu of a square operating nut and shall also have a non-rising stem. The valves shall also open by turning counterclockwise. The wheel shall have an arrow cut in the metal indicating the direction of opening. Flanges shall not be buried. An approved vault shall be provided for all flange connections.

All valves shall be manufactured in strict accordance with the latest specifications of ANSI/AWWA standards. Valves shall be manufactured by: Mueller Company, Clow Corporation, or American Darling Company. Certification shall be furnished to PWC by the manufacturer that all valves are in accordance with these specifications.

Where specified on the plans and approved by PWC, resilient valves shall be supplied with gearing. Spur gearing for valves installed in a vertical position and bevel gearing for valves

installed in a horizontal position. In cases where valve locations on plans do not designate valve gearing and the proposed depth of water main is not adequate to achieve normal depth above valve bonnet of at least two (2) feet in cover, provide bevel gearing for all large diameter valves (16-inches and larger) upon approval by PWC.

**Page 10-67, Sub-article 1036-7 (B) Bronze Gate Valves**

Replace with the following:

Bronze gate valves shall not be used. All valves smaller than four (4) inches shall be ball valves.

**Page 10-67, Sub-article 1036-7 (C) Tapping Valves**

Replace with the following:

Use tapping valves conforming to Sub-article 1036-7(A) with appropriately sized openings, with flanged by mechanical joint ends and pressure rated at 250 psi.

Resilient seated tapping valves shall be furnished with the tapping flange having a raised face or lip designed to engage the corresponding recess in the tapping sleeve flange in accordance with MSS-SP60. Tapping valves without the raised face on the tapping flange are not permitted. The interior of the waterway in the body shall be a full opening and capable of passing a full-sized shell cutter equal to the nominal diameter of the valve.

**Page 10-68, Add Sub-article 1036-7 (F) Ball Valves**

Add the following provisions:

For all valves smaller than 4 inches, ball valves shall be used. Ball valves shall be installed in accordance with these provisions.

Ball valves shall be all bronze construction, with tee head operator and having a removable disc. Ball valves shall have threaded connections, in accordance with the standard details. Ball valves shall be manufactured and tested in accordance with ANSI/AWWA C800. The valve shall be equipped with packing nut, gland, and packing material. Ball valves shall be of an approved type made from approved materials conforming to ASTM Specifications and shall also meet the approval of PWC. The turn required to travel from fully closed to fully open on the ball valve shall be 90 degrees.

**Page 10-68, ARTICLE 1036-8 SLEEVES, COUPLINGS AND MISCELLANEOUS**

**Page 10-68, Sub-article 1036-8 (A) Tapping Sleeves**

Add the following provisions:

Water tapping sleeves shall be ductile iron mechanical joint or stainless-steel full gasket and have a minimum working pressure of 150 psi for all tapping of mains up to and including 24-inch

diameter with a branch less than or equal to 12-inch diameter. Branch diameter greater than 12-inch on 16-inch-diameter pipe and larger shall require full body ductile-iron mechanical joint tapping sleeve. Sleeves shall be able to meet the test pressure of 200 psi.

Ductile iron mechanical joint tapping sleeves shall be as manufactured by Clow, M&H, Mueller, American, or an approved equal and shall be furnished with complete joint accessories. The mechanical joint sleeve shall be compatible with type and class of pipe being tapped. The outlet flange shall be class 125 per ANSI B16.1 compatible with approved tapping valves. The sleeve shall have a mechanical joint body with end glands and gaskets. The sleeve shall include a 3/4 NPT test plug.

Stainless-steel tapping sleeves shall only be used upon authorization of PWC. Stainless-steel tapping sleeves shall be furnished with all accessories. The sleeve, lugs, bolts, and nuts shall be 18-8 type 304 stainless-steel, as provided by the manufacturer. The outlet flange shall be ductile iron or stainless-steel. The sleeve gasket shall be a grid pattern design and shall provide full circumferential sealing around pipe to be tapped. The sleeve shall include a 3/4 NPT test plug. All welds shall be passivated. The outlet flange shall be class case D per AWWA C207-ANSI 150 lb. drilling compatible with approved tapping sleeves.

The tapping sleeve and valve shall be in accordance with the PWC standard details. All tapping sleeves shall be hydrostatically pressure tested prior to the tap being accomplished. Use of air to complete the pressure test is not acceptable. The tapping sleeve shall be tested to 200 psi. The PWC project coordinator shall witness and approve the testing.

#### **Page 10-68, Sub-article 1036-8 (B) Transition Sleeves and Couplings**

Add the following material to this sub-article:

Use mechanical joint full body solid sleeves conforming to MJ fittings of this special provision of 1036-5. Sleeve shall be rated for 250 psi working pressure. Sleeves used for water main repairs and/or field adjustments or corrective measure will not be allowed unless approved by PWC.

#### **Page 10-68, Sub-article 1036-8 (C) Sampling Stations**

Add the following provisions:

Above ground sampling stations shall be provided at locations shown on the construction drawings and be NSF 61 certified. Stations shall contain a stainless steel standpipe with 1" fittings and connections with a 3/4" reducer. All stations shall be enclosed in a lockable, powder-coated nonremovable, aluminum-cast housing and have freeze protection with either internal evacuation rods or manual evacuation pump. Use Kupferle Eclipse #88-SS or approved equal.

#### **Page 10-68, ARTICLE 1036-9 SERVICE LINE VALVES AND FITTINGS**

Add the following provisions to the second paragraph:

All water service saddles for use on 2-inch PVC shall be 1-inch brass saddles as manufactured by Ford, McDonald, Mueller or approved equal.

Water service saddles for 1-inch and 2-inch taps on 4-inch, 6-inch, 8-inch, 12-inch and larger size PVC and asbestos-cement (AC) and also 4-inch and larger size iron pipe shall be ductile iron with stainless-steel strap(s), bolts, nuts, and washers. Ford Models FS 101, FS 202; Romac Models 101S, 202S; Smith-Blair Model 315, 317 or approved equal shall be used. Stainless-steel straps must be pre-formed at the factory to the specified outside diameters of the pipe.

Water service saddles with 2-inch outlet shall be double strap.

Water service saddles for pipe sizes 12- through 24-inch shall be double strap.

Water service saddles for pipe sizes exceeding 24 inches shall be as specified by the PWC Water Resources Engineering Department.

Add the following provisions to the third paragraph:

Use cast brass compression type fittings manufactured for use with copper or PE water pipe, as applicable, and conforming to AWWA C800. All brass fittings shall have a 300 psi minimum pressure rating.

**Page 10-68, ADD ARTICLE 1036-10 IDENTIFICATION OF PLASTIC OR NON-METALLIC PIPES**

For the purpose of locating plastic or non-metallic pipes, a continuous "detectable" tracer wire shall be installed. The wire shall be a minimum 12-gauge, single strand, coated copper, suitable for underground use. Splices shall be accomplished utilizing a corrosion proof wire connector. The connectors shall "lock" the wires in place and contain a dielectric sealant to prevent corrosion.

The connector shall be "Snake Bite" connector manufactured by Copperhead Industries, LLC, or approved equal. The wire shall be buried continuously along the pipe. The wire shall be "stubbed" into the valve boxes and secured in accordance with PWC's standard details. Bolts shall be used to secure the detectable wire and the attachment location shall be readily available from finished grade without special equipment. The wire shall be installed with all non-metallic pipelines.

**Page 10-68, ADD ARTICLE 1036-11 VALVES BOX**

Valve boxes shall be "slip-type" made of close-grained, gray cast iron metal painted with a protective asphaltic coating. Construction shall be in three pieces as follows: The lower of base pieces, which shall be flanged at the bottom, the upper part which shall be flanged on the lower end, and of such size as to telescope over the lower part, the upper end being constructed in the form of a socket to receive the cap or cover; and the cover or cap shall have cast on the upper surface, in raised letters, the word "WATER". All valve boxes shall be equal in quality and workmanship to those manufactured by Sigma Corporation (VB-462), Tyler Union (6855 Series), Star Pipe Products (VB-0004), or an approved equal. Valve box shall have a 3/8-inch hole drilled in the upper part 4-to-6-inches from the top of the box to accommodate a 1/4-by-1 1/2-inch

galvanized bolt for securing tracer wire. The valve box shall be in accordance with the PWC standard details.

Valve box protector rings shall be installed to protect valve boxes located outside pavements (i.e., roadway shoulders). The ring shall be constructed in accordance with the PWC standard details.

**DIVISION 15-UTILITY CONSTRUCTION****SECTION 1500-GENERAL UTILITY REQUIREMENTS****Page 25-1 ARTICLE 1500-2 COOPERATION WITH THE UTILITY OWNER****Page 15-1, Sub-article 1500-2 Cooperation with Utility Owner**

Add the following sentences after paragraph 2

The Utility Owner is the Fayetteville Public Works Commission (PWC). The contact person is Kevin Heaphy, P.E. and can be reached by phone at (910) 223-4740.

After Line 24, Add the following:

(1) Fire hydrant accessibility:

Existing fire hydrants shall be accessible to the Fire Department at all times. Fire hydrants shall not be taken out of service without PWC's written approval. The Fire Department shall be notified of any fire hydrant taken out of service.

If the fire hydrants need replacement, relocation, or connected to a new water main, the PWC and the appropriate Fire Department shall be notified and coordinated with prior to commencing work. Fire hydrants shall not be removed from service without prior approval of the PWC. The existing fire hydrants shall be returned to PWC. Fire hydrants not in service shall be covered with burlap bag, whether existing or new.

The Contractor shall notify PWC and the applicable Fire Department of when and what area they will be working. The Contractor shall notify PWC and the Fire Department a minimum of 48 hours prior to commencing work. The Contractor shall coordinate with PWC and the appropriate Fire Department regarding the placement of temporary fire hydrants.

(2) Construction around utility poles and guy wires:

The Contractor will be required to perform construction work around utility poles and guy wires which may be left in place within the construction limits of the project.

The Contractor shall contact the owner of the utility to coordinate securing the poles during construction. It may be necessary for the Contractor to hire an electrical utility contractor to secure poles. All work outlined in this paragraph shall be at no additional cost to the Department and/or PWC.

**Page 15, ARTICLE 1500-3 UTILITY LOCATIONS AND CONTRACTOR'S RESPONSIBILITY**

Page 15-1 after Line 32, Add the following paragraphs:

Mapping of existing water and sewer lateral facilities

Add the following paragraphs that designate site layout and staking responsibilities for the proposed water and sewer utility work:

Construction staking will be performed by the Department (NCDOT's Division Office), who will also prepare and furnish construction cut sheets to PWC, and the Contractor. PWC will review submitted cut sheets to ensure adherence to the cut sheet requirement. The Contractor shall not install any utilities without an approved cut sheet. All requests for staking will be made not less than 96 hours in advance.

Utilities shall be installed at the locations and elevations indicated on the cut sheets unless otherwise approved by PWC. Should a conflict arise between the Contract Drawings and the cut sheets, the cut sheets shall take precedence. Contractor shall make PWC aware of any conflict between the Contract Drawings and the cut sheets as soon as it is discovered. The Contractor shall verify invert elevations of all PWC water and sewer utilities, water mains, sewer mains, water laterals, sewer laterals, and manholes by instrument.

(1) Repair of any damage to existing water services by Contractor caused damage

The Contractor shall replace the existing water services that are damaged as a result of their operations in accordance with these Special Provisions. Damaged water services shall be replaced from the meter to the existing main utilizing copper tubing and all new fittings. The Contractor shall properly abandon the existing tap, and install a new tap, utilizing a new tapping saddle and corporation stop in accordance with these Special Provisions.

The Contractor shall be responsible for connecting the new tailpiece to the customer's existing service utilizing brass fittings. The Contractor is responsible for all necessary fittings in order to connect the copper tubing to the existing meter.

The existing meter boxes shall be replaced as part of the renewal of the water services. A composite, HS-20 rated meter box shall be used if the meter is to be located in or adjacent to asphalt or concrete pavements, or where vehicles may receive incidental HS-20 traffic. The Contractor shall be responsible for furnishing and installing the meter boxes. All work shall be in accordance with PWC standard details and shall be approved by PWC.

**Page 15-1, ARTICLE 1500-4 WEEKEND, NIGHT AND HOLIDAY WORK**

Add the following paragraphs:

During the course of construction, it may be necessary to complete portions of the Work outside of the normal working hours, to accommodate PWC's operations, traffic, and/or public



convenience. The Department, Contractor, and PWC will determine an acceptable schedule required for Work during such hours. The costs for such Work shall be considered incidental to the Project and no additional payment will be made.

Legal holidays observed by the Fayetteville Public Works Commission include New Year's Day, Martin Luther King's Birthday, Good Friday, Memorial Day, Independence Day, Labor Day, Veterans Day, Thanksgiving (2 days), and Christmas (2 days).

PWC Inspector overtime shall be charged if the Contractor works outside of regular working hours. The overtime will be charged at a rate of \$100.00 per hour. Inspector overtime may be waived for circumstances beyond the Contractor's control, as determined by the PWC Project Engineer.

**Page 15-1, ARTICLE 1500-5 RELATION OF WATER MAINS TO NON-POTABLE WATER LINES AND OTHER UTILITIES**

Add the following paragraph:

Relation of water mains to sewers shall also apply to all sewer lateral crossings (4-inches and 6-inches).

**Page 15-1, Add Sub-article 1500-5 (A) Crossing Existing or Proposed Utilities**

The Contractor shall conduct their operations so that the following requirements are adhered to:

- (1) Underground telephone, cable TV, and gas utilities or conduit banks shall be crossed maintaining a minimum of 12-inch separation or clearance.
- (2) Electrical crossings shall be performed while the conductor is de-energized and at all times in the presence of PWC. Electrical crossings shall be in accordance with NESC requirements. Electrical primary conductor crossings shall be as follows:
  - a. Crossing over a conductor, maintain a minimum of 12-inches of undisturbed soil encasing the conductor.
  - b. Crossing under a conductor shall be accomplished by boring, maintaining 12-inches of undisturbed soil encasing the conductor.

**Page 15-2, ARTICLE 1500-7 SUBMITTALS AND RECORDS**

Revise the third sentence of the first paragraph to read:

Provide two (2) paper copies and one (1) electronic (.pdf) copy to the Engineer and the utility owner.

Add the following sentences after line 30:

The Contractor shall not perform any portion of the utility work requiring submittal and review until the respective submittal has been reviewed and approved by PWC. Water and sewer work performed prior to review and acceptance shall be at the Contractor's risk.

The Contractor shall provide submittals on the following:

- (1) A sample door hanger, notifying the residents of the project and those times that the resident may not have water service.
- (2) Identification of the proposed project superintendent and representative authorized to act on behalf of the Contractor.
- (3) Proposed project schedule. The schedule shall include the sequencing and coordination of connections to existing water mains, pipeline inspections, trenchless crossings, temporary water main set up and removal, sewer bypass pumping set up and tear down, and final restoration.
- (4) All piping, fittings and structures including that to furnish temporary water during extended service interruptions.
- (5) Sewer bypass pumping-as outlined in these Special Provisions.
- (6) Contractor personnel emergency contact information.
- (7) All piping fittings and structures for use with all new installations.

**Upon completion of the project, prior to the Contractor de-mobilizing and before payment for associated items, the Contractor shall cooperate with PWC to verify utilities are completed in accordance applicable requirements and that all punch list items have been completed/corrected to the satisfaction of PWC.**

PWC Sewer Work:

- (1) Manholes located outside of pavement must have a PWC issued marker.
- (2) All manholes having cam-lock ring and covers shall be locked.
- (3) Install a PWC issued marker at all valve and combination air valves at manholes outside of pavement as directed by PWC.
- (4) Verify all plugs have been removed from the sanitary sewer system..

Water Work:

- (1) Verify all valves are fully open.
- (2) Verify all valves are accessible and can be operated.

Upon completion of the Work, the Contractor shall provide two complete sets of drawings recording all changes to the work to indicate actual installation. The plans shall include coordinates of utility controls and horizontal and vertical locations of the piping sealed by a North Carolina Professional Land Surveyor (PLS). Changes shall be noted in legible red letters. These changes shall include but are not limited to the following:

- (1) Change in lateral location
- (2) Change in pipe material (including actual limits of pipe restraints)
- (3) Change in manhole location

- (4) Location of ductile iron installed on existing AC water mains
- (5) Size, depth, and installed elevations of mains, laterals, force mains, and manholes
- (6) Location of valves, blow-offs, and other appurtenances

As-built plans provided as PDF formatted files shall be generated from the source electronic files, not scanned facsimiles of paper plan sheets. Provide record drawing as-builts as PDF files and AutoCAD (.dwg) files, version 2018 or later format to the Engineer and utility owner.

### **Page 15-2, ARTICLE 1500-8 LOCATING AND MARKING**

Add the following requirements:

For identification of plastic water services, the tracer wire shall be buried continuously along the water service lateral from the main to the meter box. The wire shall extend a minimum of 12 inches into the meter boxes.

For identification of plastic or non-metallic pipes, a tracer the wire shall be buried continuously along the pipe. The wire shall be "stubbed" into valve boxes and secured such that a direct/conductive metal detector may be used to trace the pipe location. Bolts shall be used to secure the detectable wire and the attachment location shall be readily available from finished grade without special equipment. The wire shall be installed above with all non-metallic pipelines.

### **Page 15-2, ARTICLE 1500-9 PLACING PIPELINES INTO SERVICE**

Replace last two sentences with the following:

Obtain approval from PWC prior to placing a new water line into service. Use backflow prevention assemblies for temporary connections to isolate new water lines from existing water line. A representative from PWC shall witness all tests performed on their water facilities.

Add the following:

Prior to final inspection, all sanitary sewer laterals, mains, and manholes newly installed on the collection system shall be flushed and cleaned. During the flushing operation, the downstream manhole shall be closed with a watertight plug to protect the existing sewer main. All water and debris shall be removed and properly disposed of by the Contractor. This condition shall be maintained until PWC issues acceptance of the work.

#### **(1) Planned service interruptions on PWC-owned lines:**

Coordination of temporary interruptions to water and/or sewer services shall be the responsibility of the Contractor. The Contractor shall schedule a coordination meeting with the Department and the PWC Project Coordinator a minimum of three (3) business days prior to any planned service

interruption and prior to any notices being issued. The purpose of this coordination meeting is to ensure that the Contractor has a good understanding of the requirements related to the proposed outage, verify that there are no utility conflicts, discuss any necessary contingency plans, and all equipment, materials, tools, and all other incidentals necessary to complete the work are on the project site in good working order. Should, for any reason, the Department and/or PWC deem that the Contractor is not prepared for the proposed outage, the outage notifications will not be **distributed**, and the outage shall be postponed a minimum of two (2) weeks. The Department will provide written notification to the Contractor of this decision. No additional contract time will be granted for this delay.

The duration of the service interruption shall be coordinated with the Department and PWC. Service interruptions to residents shall be limited to no more than eight (8) hours at any given time. If the service interruption is anticipated to exceed eight (8) hours, temporary service shall be provided. The Contractor shall provide all the necessary equipment and materials for temporary service. The notifications shall describe the work to be undertaken and approximate dates of the work. The text of the notifications shall be approved by the Department and PWC in advance. The Contractor shall furnish a copy of the notification to the PWC Project Coordinator each time such notification is issued to the residents.

Whenever the property owner's use of the water and/or sanitary sewer must be interrupted by the Work, the Contractor shall notify the residents a minimum of 48 hours prior to service interruption. This notification shall be accomplished with door hanger notification cards placed at the addresses of the affected residents. Property owners shall be informed when service interruption takes place and the expected duration. The Contractor shall make every effort to minimize inconvenience to the public and property owners.

The Contractor shall complete the required work and restore water service within the given time period for the outage. PWC reserves the right to cancel or postpone the outage at any time, for any reason.

**(2) Furnishing pressurized, temporary water service:**

Provide and maintain pressurized, temporary water supply to all services connected to water mains that must be depressurized and/or interrupted for any reason related to the Work including cut in construction and ties in. The only exception to this requirement is the performance of emergency repair and if the planned interruption of service is expected to last less than eight (8) consecutive hours. Provide temporary water supply if the interruption extends past eight (8) consecutive hours.

Maintain and operate temporary water supply until completion of required disinfection and flushing procedures and, receipt of confirmation of acceptable bacteriological test results for the section of water main that was interrupted or as otherwise directed by PWC.

The Contractor shall submit a detailed temporary water layout plan to PWC prior to the planned outage. The Contractor will be responsible for furnishing, installing, maintaining, and removing

all temporary water lines during the course of the work. All costs associated this item shall be incidental for the work that is needed for.

The temporary lines shall be leak free and installed in a neat and orderly fashion. The Contractor shall be responsible for protection of the temporary line and shall provide the personnel necessary to immediately respond to all water line breaks, leaks, and outages associated with the project. A 24-hour "hotline" shall be established for PWC to call when a problem arises with the temporary water system. Any leaks on the temporary water service lines shall be repaired immediately. The Contractor shall also take all necessary precautions to protect the temporary water system from freezing and shall include freezing protection procedures in the temporary water layout plan.

The Contractor shall connect the temporary water system directly to the customer's meter, utilizing approved fittings. This may necessitate the meter being placed outside of the meter box. During weather that may result in the meter and/or temporary service lines freezing, the Contractor shall take all reasonable precautions. to prevent the meter and/or temporary bypass lines from freezing.

Fire protection must be maintained at all times during construction. Temporary fire hydrants must meet the approval of the applicable Fire Department, prior to their use.

Prior to installing any temporary service lines, the Contractor shall verify the need for such lines, especially on streets with multiple water mains. Any costs incurred by installing temporary water lines that are not needed shall be at the Contractor's expense.

Backflow prevention measures will be required when the temporary water system is serving any commercial businesses. Backflow prevention measures will not be necessary when the temporary water system is only serving residential homes. Where backflow prevention is required, a reduced pressure device shall be utilized in accordance with PWC's standards and PWC's Cross-Connection Control Ordinance. The Contractor shall call PWC's Environmental System Protection Department (910-223-4699) for additional information and requirements and shall notify the PWC Project Manager and Project Coordinator of all information.

Restrained joint PVC piping will be allowed if properly placed so as to prevent its damage by traffic. All temporary service pipe crossing streets and/or commercial driveways must cross in a fashion that will not create a traffic hazard. Boring or punching may be required when crossing streets with high traffic volume or higher speeds. Temporary piping crossing sidewalks or wheelchair access ramps must be ramped or buried. Any temporary water lines crossing a driveway shall be covered with a rubber ramp or bituminous cold patch provided by the Contractor. When temporary paving is used to ramp temporary services lines, it must be compacted by a roller or compaction device to minimize tracking. The Contractor is to maintain ramps and patches to ensure access by public. Piping must be buried when so directed by the Department and/or PWC. All temporary water piping connected to fire hydrants shall be constructed in such a manner that if necessary, can be easily removed so the fire hydrant can be used for firefighting purposes with minimal effort. All such connections to the fire hydrants must be compatible with applicable Fire Department requirements for each fire hydrant outlet used. Where fire hydrants cannot be used or are not available, the Contractor shall make below ground taps for bypass connections.

Direct connections to the existing water system will not be allowed until disinfection is complete and each section of temporary line, including service lines, has passed bacteriological and turbidity testing. All dead-end temporary services lines shall be equipped with a temporary blow-off.

Temporary service lines longer than 750 linear feet must have a supply at each end. Temporary service lines must have a main line shut off valve at least every 500 feet. Fire protection must be maintained at all times during construction.

Upon activation of the newly relocated or installed pipe, the Contractor shall remove all temporary service lines and shall leave all streets, sidewalks, and adjacent properties in a condition of equal or better than original. Prior to installing the meter and connecting the customer to the new main, the existing service line shall be thoroughly flushed to remove any deposits collected during the work.

The pipe, hoses, and other materials which are to be furnished by the Contractor for use as temporary service pipe shall be clean, watertight and fully adequate to withstand the existing pressure and all other conditions of use and shall be approved by PWC. Care shall be exercised throughout the installation of all temporary pipe and service fittings to avoid any possible contaminations of any mains or services.

All piping utilized in the temporary water system shall be NSF Standard 61 certified for use in potable water applications or FDA CFR 177.2600 approved, for use in contact with food articles, if such use is approved by NCDEQ. The Contractor may utilize PVC pipe only if the pipe is equipped with restrained joints.

### **(3) Testing and Disinfection**

The Contractor shall coordinate and fully cooperate with PWC when scheduling testing. The Contractor shall provide a minimum of two (2) business days' notice when scheduling testing with PWC. All testing shall be in accordance with these special provisions.

All temporary water piping, newly lined mains, and newly installed mains shall be flushed and disinfected prior to placing into service. For water samples on PWC's- owned water mains, the PWC Project Coordinator shall take the appropriate sample(s) to the PWC lab for analysis. Upon successful completion of the disinfection process, the water lines can be placed into service. Disinfection shall be in accordance with these Special Provisions. All water samples from PWC's owned mains shall be taken to the PWC Lab by the PWC Project Coordinator.

The Contractor shall provide all equipment, materials, personnel, traffic control and all means necessary to perform all testing and inspection at no additional cost to the Department. If the same line segment fails the required testing more than two (2) times, PWC will charge a fee of \$100.00 per test, beginning with the third attempt, until a passing test achieved.

All environmental regulations governing the release and/or disposal of chlorinated testing water shall be met by the Contractor. AWWA C655 defines "highly chlorinated" water as water having

more than 4 ppm. Any water with a chlorine level greater than 4 ppm shall be de-chlorinated by the Contractor prior to being released to the environment.

The disinfection chlorine level will be checked by the PWC Project Coordinator a minimum of 24 hrs. after the initial disinfection. If the chlorine level is found to be acceptable at that time, the Contractor will be required to flush and remove the disinfection chlorine from the main to allow for sample collection. Should the chlorine level be found unacceptable, the disinfection process shall be repeated. The cost of the system disinfection and disposal of the chlorinated water shall be included in the appropriate measurement and payment item.

## **SECTION 1505-EXCAVATION, TRENCHING, PIPE LAYING AND BACKFILLING FOR UTILITIES**

### **Page 15-4, ARTICLE 1505-3 CONSTRUCTION METHODS**

#### **Page 15-4, Sub-article 1505-3 (C) Bedding**

Add the following paragraph:

##### **Gravity Flow Sewer Pipe**

The bottom of the trench shall be excavated to a minimum of four (4) inches below the outside bottom of the pipe being installed to allow adequate placement and compaction of bedding material prior to installation.

Crushed stone bedding material shall be placed a minimum of four (4) inches deep and a maximum of six (6) inches deep under the pipe for full width of the trench and halfway up the pipe on the sides. Bedding material shall be placed in layers not exceeding 6-inch-loose thickness for compacting by vibratory mechanical tamps under the haunches and concurrently on each side of the pipe for the full width of the trench. The final result shall be "Class B" bedding for rigid pipe. If the existing material under the pipe bedding material is unsuitable, the unsuitable material shall be removed and replaced with stone bedding material (No. 57 or No. 5 stone), as authorized and approved by PWC.

#### **Page 15-4, Sub-article 1505-3 (D) Pipe Laying**

Add the following paragraphs:

All pipes and fittings shall be carefully lowered into the trench in such a manner to prevent damage to the protective coatings and linings. Under no circumstances shall pipe materials be dropped or dumped into the trench. Pipe shall be carried into position and not dragged.

All dust, dirt, oil, tar (other than standard coating), or other foreign matter shall be cleaned from the jointing surfaces, and the gasket, bell, and spigot shall be lubricated with lubricant recommended by the manufacturer.

All pipe shall be installed in accordance with the approved plans and cut sheets, unless otherwise directed by PWC.

For water pipe and sewer force main pipes sizes up to 12 inches, mechanical equipment shall not be used to assemble the pipe. For water pipe and sewer force main pipes sizes over 12 inches, mechanical equipment may be used, in accordance with the pipe manufacturer's instructions. Any damage resulting from the use of mechanical equipment shall be replaced as directed by and at no additional cost to PWC or the Department.

Gravity flow sewer pipe shall be laid upgrade, beginning at the lower end with the tongue or spigot ends pointing in the direction of the flow to the correct line and grade, unless otherwise approved by PWC. The sewer pipe section to be installed shall be aligned by batter board or laser beam with the last installed pipe section. Mechanical equipment should not be used to assemble the pipe. Pipe shall be assembled in accordance with the pipe manufacturer's instructions. Any damage resulting from the use of mechanical equipment shall be replaced as directed by PWC or the Department and at no additional cost to the PWC or the Department.

Adjustments in grade by exerting force on the barrel of the pipe with excavating equipment will not be allowed. The Contractor shall verify line and grade after assembling each joint.

No pipe shall be laid in water or where in PWC's opinion trench conditions are unsuitable. Every precaution shall be taken to prevent material from entering the pipe while it is being installed.

#### **Page 15-4, Sub-article 1505-3 (D) Pipe Laying**

Add the following paragraphs:

Pipe Laying Schedule and Marking Diagram:

Provide a laying schedule and marking diagram for all mains 16-inches and larger and for all mains that have factory restrained joints or flanged joints.

Laying schedule shall indicate by consecutive number the order and direction of installation of each pipe section or segment, length of restraint, special fitting, valves, tees, temporary taps or flushing points, and other appurtenances. In addition, the laying schedule shall include:

The station and elevation to which the bell end of each pipe shall be laid and all changes in gradient or horizontal alignment.

All elements of curves and bends, both in horizontal and vertical alignment.

Length of restraint

**Contractor shall not start production of pipe and fittings prior to review and approval by PWC.** Contractor shall provide final approved lay schedule in a portable document format. Provide final approved lay schedule on a thumb drive in portable document format (\*.PDF).



**Page 15-4, Sub-article 1505-3 (E) Thrust Restraint third paragraph**

Replace third paragraph with the following:

At locations where restrained joints are shown on the plans, use ductile iron pipe and fittings with push-on factory restrained joints. The pipe, joints, and gaskets shall be in accordance with ANSI/AWWA Standards as previously specified for ductile iron pipe in Sub-article 1036-5, Restrained joints, fittings and valves shall be rated for a working pressure of 350 psi for sizes 4-through 24-inch and 250 psi for larger sizes. All factory restrained joint pipe, valves, and fittings shall have the restraints internal to the pipe (i.e., "boltless"). The use of mechanical restraints are not allowed, unless otherwise specifically directed in writing by PWC. All valves, pipe, and fittings shall be compatible with the factory restraint system. All push-on factory restrained joint ductile iron pipe and fittings shall be as manufactured by U.S. Pipe's TR-Flex, Griffin Pipe Products SNAP-LOK, American Cast Iron Pipe Company's Flex-Ring Joint, or approved equal.

Special accessories such as mechanical joint retainer glands or field locking gaskets are acceptable on pipe 12-inch and less in diameter, upon approval from PWC. Use concrete reaction blocking and thrust collars only where joint restraint is impractical and with the approval of PWC.

Concrete thrust blocking shall be used on all PVC water mains unless shown otherwise on the plans. The concrete thrust blocking shall be in accordance with PWC's standard details. When thrust blocking is to be used, backfilling shall not occur until the concrete has time to set. No hydrostatic pressure testing shall occur until the concrete thrust blocking has cured for a minimum of five (5) calendar days.

**Page 15-4, Sub-article 1505-3 (F) Backfilling**

Add the following paragraph:

**Compaction**

Backfill shall be compacted in accordance with the following table as a percentage of the maximum density at optimum moisture content as determined by the Standard Proctor Test, ASTM D-698.

<u>Area</u>	<u>Percent ASTM D-698 Area Maximum Dry Density</u>
Around and 1' above top of pipe	95
Remaining trench (within 4' of subgrade)	95
Pavement subgrade and shoulders	
- Last 1' of fill (below subgrade)	100
- Last 3' of fill to 12" below subgrade	98
Base material	100
Adjacent to structures (Areas not paved)	95
Under structures	98
Utility Outfalls (Cross Country)	95

Compaction testing may be performed at the option of the PWC Project Coordinator, or as required by the responsible agency (i.e., City of Fayetteville, NCDOT, etc.). Compaction testing shall be done in accordance with the responsible agency's requirements. Deficiencies shall be corrected by the Contractor as directed by and without additional cost to PWC.

**Page 15-5, ARTICLE 1505-5 CONCRETE ENCASMENT OF UTILITY LINES**

Replace with the following:

Water and/or sewer utility lines are not to be encased in concrete unless in writing by PWC.

**SECTION 1510-WATER LINES**

**Page 15-5, ARTICLE 1510-S2 MATERIALS**

**Page 15-5, Sub-article 1510-2 Materials**

Add the following sentences to Paragraph 5:

Clay pipe, PE pipe, steel pipe and concrete pipe shall not be used for water pipe unless approved in writing by PWC and as described below. All water pipes shall be Ductile Iron or PVC with ductile iron fittings as specified herein unless otherwise indicated on the drawings.

For subsurface water crossings (i.e., streams, wetlands) via Horizontal Directional Drilling (HDD), Fused HDPE or FPVC shall be used.

**Pipe Markings:**

- Meet the minimum requirements of AWWA C906. Minimum pipe markings shall be as follows:
  - Manufacturer's name or trademark and production record.
  - Nominal pipe size.

- DIPS.
- Dimension Ratio.
- AWWA C906.
- Seal of testing agency that verified the suitability of the pipe.
- Resin type (PE4710).

Color identification to identify pipe service is required:

- Pipe interior shall be gray for visual inspection.
- Permanent identification of piping shall be provided by co-extruding multiple equally spaced color stripes into the pipe outside surface or by solid colored pipe shell.
- The striping material shall be the same material as the pipe material except for the color.
- Plain black HDPE pipe without color code markings may not be used.

Only smooth wall HDPE will be permitted.

**Joining system:**

Pipe to be joined with butt, heat fusion joints. Joints to be made in strict compliance with manufacturer's recommendations and ASTM D2657. Where required, flange connections, mechanical joint connections and butt connections using bolted mechanical couplers to be provided from a pipe stub with a polyethylene and steel stiffener. Flanged connections to be provided from a pipe stub and a steel backup flanged. Back-up flanges to be primed and painted in a corrosion protected paint recommended and supplied by manufacturer. Bolts, nuts and hardware to be Type 316 stainless steel.

Transition between ductile iron pipe and HDPE shall be accomplished using mechanical restraints as approved by PWC.

**Page 15-6 ARTICLE 1510-3 GENERAL**

**Page 15-6, Sub-article 1510-3 (A) General**

In the sixth paragraph, replace the words "36-inches-to-42-inches of cover" with "a minimum of 42 inches of cover:"

Add the following construction method where concrete thrust blocking is required:

When thrust blocking is to be used, backfilling shall not occur until the concrete has time to set. No hydrostatic pressure testing shall occur until the concrete thrust blocking has cured for a minimum of five (5) calendar days.

Add the following construction methods for service interruptions and cut ins:

- (1) Coordinate all service interruptions with PWC and submit a shut down or service interruption work plan for review and approval by PWC a minimum of 30 calendar days prior to service interruption. Service interruption shall address all facets of the planned

outage and how the Contractor will adhere to service interruption policies and critical items defined herein. PWC will schedule a test shut down to ensure existing valves are in proper working order. Where existing valves are determined to be non-functional or unable to isolate the work area, a field directive may will be issued to insert a valve or cut in a valve if allowed by PWC and if other existing valves will not accommodate a service interruption that does not disrupt significant number of customers. A cut in valve installation shall follow these same measures.

- (2) Perform customer notification adhering to customer notification procedures as contained in these Special Provisions.
- (3) Provide sufficient construction staff or crews, certified site superintendent present, pumps of sufficient size to quickly dewater and ensure all equipment is present and functional.
- (4) Provide sufficient lighting for night operations.
- (5) Provide dual purpose sleeves, retainers glands, fittings, etc. to complete the tie in expeditiously.
- (6) Perform the following tasks in advance of the shutdown:
  - a. Evaluate vertical depth of existing main and any conflicting utilities.
  - b. Provide detailed layout plan with dimensions and fittings as part of the shutdown plan.
  - c. Complete excavation to pipe.
  - d. Preassemble fittings above ground when possible.
  - e. Place crushed rock in excavation to provide footing and minimize contamination.
  - f. Verify notification of customers has been completed.
  - g. Perform the following tasks after shutdown:
    - i. Relieve pressure off existing main through use of existing hydrants or blow-offs which are within the isolated part of the system
    - ii. Cut pipe on bottom and sides in manner to dewater pipe quickly and to avoid water spray
    - iii. Use cut out section for measurement when possible
    - iv. Disinfect fittings and pipe with chlorine solution adhering to Cut in Construction requirements of AWWA C651-14, Section 4.11 and as directed by PWC.

### **Page 15-6, Sub-article 1510-3 (B), Testing and Sterilization**

Rename to 1510-3 (B) Testing and Disinfection and replace the third paragraph with:

Perform tests **using** clean water and provide certified results demonstrating no loss of pressure when pressurized at 200 psi (plus or minus five (5) psi) for two (2) hours.

In the fifth paragraph revise the flushing velocity from 2.5 feet per second to 3.0 feet per second.

Replace the sixth paragraph (beginning at line 39) with the following:

Disinfection shall be in accordance with the requirements of NCDEQ, the North Carolina Rules Governing Public Water Supply, AWWA C651, and AWWA C655 (most recent editions). The Contractor shall furnish all disinfection equipment, solution, materials, excavation, barricades, backfilling, and any taps and corporations necessary to complete the work. The Contractor shall fully cooperate with the PWC Project Coordinator, furnish any needed assistance, and schedule the testing.

Prior to performing the hydrostatic test, water mains, laterals, and appurtenances shall be flushed to remove air, sediment, contaminants, and/or foreign matter. After completion of a successful hydrostatic test, the water system shall be disinfected by the thorough dispersion of a chlorine solution. The chlorine level shall be between 50 parts per million (ppm) and 100 ppm throughout the water system. In no case shall the chlorine level exceed 300 ppm. If the chlorine level is over 300 ppm, the system shall be completely flushed and re-chlorinated. In no case shall chlorine be introduced into the water system in a dry solid state.

The chlorine solution shall remain in contact with the interior surfaces of the water system for a minimum period of 24 hours and shall result in not less than 10 ppm of chlorine throughout the system. Then the water system shall be flushed with water from the existing PWC water system until the chlorine solution is dispelled. The Contractor shall take all necessary measures to prevent downstream erosion caused by flushing the lines. All erosion/damages shall be repaired at no additional expense to the Public Works Commission. All environmental regulations governing the release and/or disposal of chlorinated testing water shall be met by the Contractor. AWWA C655 defines "highly chlorinated" water as water having more than four (4) ppm. Any water with a chlorine level greater than four (4) ppm shall be de-chlorinated by the Contractor prior to being released to the environment.

If any disruption to the disinfection process occurs, or if any repair procedure is necessary then the disinfection process shall start over.

After disinfection, the water supply shall not be accepted or placed into service until bacteriological tests results or representative water samples analyzed in the Public Works Commission's laboratory are found to be satisfactory. The disinfection shall be repeated until tests indicate the absence of pollution for at least two (2) full days. The PWC Project Coordinator shall be responsible for collecting the sample(s) and transporting them to the PWC laboratory.

If the initial sample taken after disinfection and flushing does not indicate that the water main is sterilized, the Contractor shall, in conjunction with the PWC Project Coordinator, flush the lines. Once flushing is complete, another sample will be collected and taken to the Public Works Commission's laboratory for analysis. Should this second sample also fail to indicate that the main is sterilized; the Contractor shall repeat the disinfection process. This process shall be repeated until the samples are satisfactory. The Contractor shall fully cooperate with the PWC Project Coordinator, furnish any needed assistance, and schedule the testing.

Each valved section shall be tested individually. Where any section of a water line is installed with concrete thrust blocking for fittings or hydrants, the hydrostatic test shall not be made until at least five (5) days after installation of the blocking.

Each valved section of pipe shall be slowly filled with water and to the specified test pressure based on the elevation of the lowest point of the line or section under test and corrected to the elevation of the test gauge, shall be applied by means of a pump connected to the pipe in a manner satisfactory to PWC. Before applying the specified test pressure, all air shall be expelled from the pipe. If hydrants or blow offs are not available at the high places, taps shall be made to provide blow offs at no additional cost to the Department or PWC.

Any taps which are not to be used in the final build out (i.e., testing and/or blow off taps) shall be killed out at the main. If these taps are converted to irrigation taps they must be installed according to the drawings and be witnessed by PWC. PWC shall be present and observe all valve operation by the Contractor. Under no circumstances shall a Contractor tamper with any valves not installed by him unless it is an emergency.

Damaged or defective materials discovered as a result of the pressure test shall be removed and replaced with new material, and the test shall be repeated until the test results are satisfactory to PWC.

All replacement, repair or retesting shall be accomplished at no additional cost to the Department or PWC. All repairs shall be reviewed and approved by PWC prior to backfill. The use of couplings, fittings, sleeves, etc. shall be reviewed and approved by PWC prior to use. The system must successfully pass the hydrostatic test prior to disinfection.

#### **Page 15-6, Add Sub-article 1510-3( C ) Alignment and Grade**

All pipe shall be installed to the required lines and grades. Structures shall be installed at the designed locations. The lines of the pipe will generally be indicated by stakes parallel to the line of the pipe. The Contractor shall be responsible for installing the pipe to proper line and grade.

If alignment requires deflection in excess of the specified limitations or as determined by PWC, bends shall be used. Joint deflection shall not exceed 80% of the limits recommended by the pipe manufacturer.

#### **Page 15-6, Add Sub-article 1510-3( D ) Piping and Fittings**

All ductile iron pipe and fittings shall be installed in accordance with ANSI / AWWA C110 / A21.10. All C900 PVC pipe shall be installed in accordance with ASTM D-2321. The PVC pipe shall be installed in a manner that will ensure that external loads will not subsequently cause a decrease of more than five percent (5%) in the vertical cross section dimension (deflection). Whenever it is necessary to deflect pipe, the amount of deflection allowable shall not exceed seventy five percent of the maximum values represented in the AWWA standards and the manufacturer's recommendations.

When pipe is field cut, the cut end shall be smooth and at right angles to the axis of the pipe. All sharp edges shall be removed. All field cut pipe shall be beveled. The beveled end of PVC pipe shall be removed, when installing into mechanical joint ductile iron fittings.

Pipe passing through walls of NCDOT bridges, retaining walls, and other concrete structures shall be factory restrained push-on joint ductile iron and be installed in casings/sleeves in accordance with NCDOT specifications. Annular space between walls and sleeves shall be filled with an approved cement mortar that meets NCDOT specifications. The annular space between the sleeve and the pipe shall be filled with an approved mastic.

Pipe passing through the walls of meter vaults, valve pits, and storm drainage structures shall be restrained joint ductile iron

When connecting unlike (class, material, etc.) pipe, an a PWC approved fitting shall be used. All pipe shall be installed in accordance with AWWA C600 for buried lines and the manufacturer's recommendations. For mechanical joint pipe and fittings, all nuts shall be tightened with a suitable (preferable torque-limiting) wrench. The torque for various sizes of bolts shall be in accordance with the manufacturer's instructions. If unlike pipes within the PWC system have to be connected, PWC shall approve any fittings proposed to connect the material prior to installation.

Proposed conflict boxes with storm and water shall be reviewed by PWC and approved on a case-by-case basis.

## **SECTION 1515-UTILITY CONTROLS**

### **Page 15-7 ARTICLE 1515-2 MATERIALS**

Add and/or revise the following:

Page 15-8, After Line 4-Add the following paragraphs:

**Combination Air Release Vacuum Valves** shall be of the single housing style that combines the operation features of both an air/vacuum and air release valve. All air and vacuum combination release valves shall be Crispin Model UX20, ARI D-020, H-Tec Model 986, or approved equal. All air release valves shall be installed in accordance with the manufacturer's recommendations.

The valve body, cover flange, and all internal parts shall be 316 stainless-steel or reinforced nylon with the only exception being the Buna-N Rubber seat and gasket. Valves shall be provided to the Contractor.

The valve shall have a 2-inch inlet and 1-inch outlet connections, and 3/16-inch diameter orifice or determined by the Engineer and approved by PWC for a maximum working pressure of 200 psi. Valve shall have a single float design.

The valve shall be installed using a 2-inch ball valve, and a 2-inch-by-1-inch brass tee with a quick connect attachment as shown in the PWC standard detail. Ball valves shall be all bronze construction, with a handle operator. Ball valves shall be manufactured and tested in accordance

with ANSI/AWWA C800. The valve shall be equipped with packing nut, gland, and packing material. Ball valves shall be of an approved type made from approved materials conforming to ASTM specifications and shall also meet the approval of PWC. The turn required to travel from fully closed to fully open on a ball valve shall be 90 degrees.

Service saddles for 2-inch taps on 4-inch and larger size iron pipe shall be ductile-iron with stainless-steel double straps, bolts, nuts, and washers. Saddles shall be as manufactured by Geneco or an approved equal. Saddles for pipe sizes 8-inch through 24-inch shall be double strap.

Manhole, frame and cover shall be in accordance with PWC details. For water lines, lid shall indicate "WATER."

Air relief and vacuum valve manholes shall be 60-inch-diameter precast concrete units conforming to ASTM C-478. The combination air relief vacuum valve manhole shall be cast with an anti-microbial admixture, in accordance with manufacturer's instructions. The manholes and valves shall be installed in accordance with the standard PWC detail.

Cast iron manhole frames and covers shall conform to the drawings in all essentials of design with vent holes. The frames and covers shall have a combined weight of not less than 310 pounds and shall conform to ASTM A-48, Class 30 frame, and Class 35 cover. Lettering on the cover shall conform to the City of Fayetteville Public Works Commission standards and shall be stamped or cast into all covers **in accordance with PWC's standard detail**. Unless otherwise shown on the drawings, the frames and covers shall be so set that the top of the cover will be flush with finished grade or as directed by PWC

The valve shall be centered in the manhole for water mains and offset 12 inches from the center of the manhole for sewer mains. Top of the water or sewer main shall be a minimum of four(4) feet deep at Air Release Valve, unless otherwise required due to the main and/or combination air release valve size.

The force main shall consist of one full length of PVC C-900 (DR18) pipe centered at the air relief valve and a minimum of 4-feet-deep.

Page 15-8, Line 5- Replace paragraph beginning "Double check valves..." with the following:

Double Check Valves (DCV) and Reduced Pressure Zone principal (RPZ) backflow prevention assemblies shall be on PWC's list of approved backflow devices.

Page 15-8, Line 15-Remove "screw or". Only slip type valve boxes are permissible.

Page 15-8, After Line 17-Add the following paragraphs:

Use Type K copper tubing for all 1-inch water services installed, repaired or relocated. Use a continuous run, without splices, from the corporation stop to the meter for all water services.



If a two (2) inch meter box is located less than five (5) feet away from the main or as directed by PWC, the two (2) inch pipe and fittings shall be brass from the tap to the meter. Otherwise, use two (2) inch PVC SDR 21 pipe.

**Page 15-8, ARTICLE 1515-3 CONSTRUCTION METHODS**

**Page 15-8, Sub-article 1515-3 Construction Methods**

Add the following to the second paragraph:

Provide) four (4) NCDOT concrete blocks at each valve box section and two (2) inch meter box, in accordance with the PWC standard details. Provide NCDOT concrete brick as a meter box base for 1-inch services, in accordance with PWC standard detail.

**Page 15-8, Sub-article 1515-3 (A) Valves**

Replace the first paragraph as follows:

Valves in water mains shall be located as shown on plans. Install all valves with an approved valve box set flush with the finished ground or finished pavement elevation. Place a 24-inch diameter 2,500 psi precast concrete ring flush with the finished ground around all valve boxes not in pavement. Place a 24-inch diameter 3,000 psi poured in place concrete collar flush with the finished pavement around all valve boxes in a traffic area. Complete work in accordance with standard PWC details.

Add the following after the second paragraph (Line 30):

The valve shall be fully opened and fully closed to ensure that all parts are in working condition. A valve box shall be provided for every valve. Valves and valve boxes shall be installed in accordance with PWC details. The valve box shall be centered and plumb over the operating nut of the valve. It shall not transmit shock or stress to the valve. Valves shall be installed in accordance with the standard PWC details.

All tapping sleeves shall be hydrostatically pressure tested prior to the tap being accomplished. Use of air to complete the pressure test is not acceptable. The tapping sleeve shall be tested to 200 psi. PWC shall witness and approve the testing.

All dead ends on new mains shall have a 2-inch blow-off assembly installed as indicated on the drawings. The blow-off assembly shall be in accordance with the standard PWC details.

**Page 15-8, Sub-article 1515-3 (B) Meters**

Add the following:

Connect or reconnect meter to the customer's plumbing using brass fittings. A composite, H-20 rated meter box shall be used if the meter is to be located in asphalt or concrete pavement or a traffic area. The meter boxes shall be in accordance with the PWC standard details.

**Page 15-8, Sub-article 1515-3(C) Backflow Prevention Assembly**

Add the following:

Provide a minimum of five (5) feet between the meter and the backflow preventer.

**Page 15-9, Sub-article 1515-3 (D) Fire Hydrants**

Add the following:

Fire hydrants shall be located and installed as shown on the approved drawings and installed in accordance with PWC standard details. Each fire hydrant shall have a minimum of 42-inches of cover. Fittings between the valve and fire hydrant may be used with prior approval from PWC. The valve shall be located at the main unless otherwise approved by PWC. Hydrants shall be set plumb with pumper nozzle facing the roadway. Each fire hydrant shall be restrained to the pipe with suitable mechanical joint restraint, in accordance with PWC standard details. Concrete thrust blocking shall be placed in accordance with PWC standard details. The hydrant branch shall not be backfilled until inspected and approved by PWC.

**Page 15-9, Sub-article 1515-3(E) Line Stops**

Add the following:

Do not use line stops without the authorization of PWC.

**Page 15-9, Sub-article 1515-3 (F) Air Release Valves and Combination Air Valves**

Add the following:

Combination Air Release Vacuum Valves shall be installed in accordance with the standard details.

**Page 15-9, ARTICLE 1515-4 MEASUREMENT AND PAYMENT**

Page 15-9, after line 35- Add the following:

Payment for Combination air release valve shall be per each valve and paid for under the contract price for Combination Air Valve". Such price and payments will be full compensation for all labor, materials, excavation, backfilling, and any incidentals necessary to complete the work, as required. Contractor shall furnish all accessories and fittings for a complete installation.

All Combination air valves furnished by PWC shall be installed at the locations shown on the drawings.

Page 15-9, After Line 40-Add the following after the *Relocate* paragraph:

Relocate all existing automated meter (AMI) assemblies to new location. Where existing meters to be relocated are non-AMIs, PWC will provide and install the new AMIs. PWC Project Coordinator will coordinate the connection of the old new meters to the new system.

Page 15-9, Line 43- Revise *Reconnect Water Meter* paragraph as follows:

Reconnect Water Meter means to replace the piping from a new water line to an existing water meter that is not relocated. New lateral shall be provided from new water main to existing and/or relocated water meter.

Page 15-10, After Line 3-Add the following after *Valve boxes* paragraph:

Meter box, meter setter, connection of new lateral to meter setter and reconnection of existing plumbing to tailpiece utilizing brass fittings are incidental items.

## **SECTION 1520-SANITARY SEWER**

### **Page 15-10, ARTICLE 1520-2 MATERIALS**

Page 15-11, After Line 10-Add the following:

#### **Force Main Sanitary Sewer Tracer and Markers**

For PVC force main sewer pipes, the tracer wire shall be "stubbed" into marker posts and air release valve manholes and secured such that a "direct"/conductive metal detector may be used to trace the pipe location.

The marker posts shall be green with a "Sewer Force Main" warning and have internal terminals. The marker posts shall use an anchor for direct bury installations. The identification wire shall be attached to the marker posts in accordance these Special Provisions. Tracing wire marker posts shall be located no more than 500 feet apart.

When the force main is located in unpaved areas such as easements the marker posts shall be installed along the centerline of the force main. When the force main is located in paved areas the marker posts may be offset from the centerline of the force main in a uniform manner.

#### **Pipe Materials and Fittings**

Clay pipe, PE pipe and concrete pipe shall not be used for sewer pipe unless approved in writing by PWC and where described below. All sewer pipes shall be Ductile Iron or PVC with ductile iron fittings as specified herein unless otherwise indicated on the drawings.

If PWC determines that an expansion coupling is required, it shall be installed as indicated on the drawings. The expansion coupling shall not be buried.

For subsurface water crossings (i.e., streams, wetlands) via auger boring or other tunneling method, restrained joint ductile iron pipe shall be used. No mechanical restraint systems (e.g.,

mega-lugs, field-lock gaskets, etc.) shall be used. The pipe shall be installed in a casing, as indicated on the drawings, unless otherwise specifically approved by PWC.

For subsurface water crossings (i.e., streams, wetlands) via Horizontal Directional Drilling (HDD), Fused HDPE or FPVC shall be used.

### **Pipe Markings**

Meet the minimum requirements of AWWA C906. Minimum pipe markings shall be as follows:

- (1) Manufacturer's name or trademark and production record.
- (2) Nominal pipe size.
- (3) DIPS.
- (4) Dimension Ratio.
- (5) AWWA C906.
- (6) Seal of testing agency that verified the suitability of the pipe.
- (7) Resin type (PE4710).

Color identification to identify pipe service is required.

- (1) Stripes or colored exterior pipe product shall be green for wastewater/sewage.
- (2) Pipe interior shall be gray for visual inspection.
- (3) Permanent identification of piping shall be provided by co-extruding multiple equally spaced color stripes into the pipe outside surface or by solid colored pipe shell.
- (4) The striping material shall be the same material as the pipe material except for the color.
- (5) Plain black HDPE pipe without color code markings may not be used.

Only smooth wall HDPE will be permitted.

### **Joining system:**

Pipe to be joined with butt, heat fusion joints. Joints to be made in strict compliance with manufacturer's recommendations and ASTM D2657. Where required, flange connections, mechanical joint connections and butt connections using bolted mechanical couplers to be provided from a pipe stub with a polyethylene and steel stiffener. Flanged connections to be provided from a pipe stub and a steel back-up flanged. Back-up flanges to be primed and painted in a corrosion protected paint recommended and supplied by manufacturer. Bolts, nuts and hardware to be Type 316 stainless steel.

Transition between ductile iron pipe and HDPE shall be accomplished using mechanical restraints as approved by PWC.

The same material pipe shall be used from manhole to manhole, unless otherwise approved by PWC. If the section of pipe between manholes is 250 feet or less, no transitions will be allowed (either all PVC or all ductile iron). Should the length between manholes exceed 250 feet, only one transition will be allowed. Ductile iron shall be installed from the lower manhole to the transition location. Use of a C900 x SDR 26 adaptor shall be used to accomplish the transition. A transition

is defined as the use of one C900 x SDR26 adaptor. No more than one (1) adaptor shall be used in any given manhole to manhole segment.

**PAGE 15-11, ARTICLE 1520-3, CONSTRUCTION METHODS**

Page 15-11, Delete Line 21 and replace with the following:

Maximum grade for sanitary sewers is 9% unless otherwise approved by PWC on a case-by-case basis. Use ductile iron where sewer is required to be installed on maximum grade. Use ductile iron where indicated on Drawings and where the following "protected" conditions are encountered:

- (1) Sewers entering or crossing streams
- (2) Sewers located less than 100 feet from any public or private water supply source
- (3) Where the minimum 18-inch vertical and 10-foot horizontal separation cannot be maintained between sewers (main and laterals) and water mains.

**Page 15-11, Sub-article 1520-3(A)(2) Testing**

Replace the second paragraph with the following:

Test all gravity sewer lines not specified to be hydrostatically tested for leakage using the air test. Perform visual inspection on all installed gravity sewer lines and the gravity sewer lines repaired or reconnected to existing and or new manholes. Perform line and grade testing and deflection testing on all gravity sewer lines.

**Page 15-12, Sub-article 1520-3(A)(2)(c) Air Test**

Replace Table 1520-1 with:

AIR TEST TIME			
Pipe Dia (in)	Minimum time (minutes)	Length for Min Time (ft)	Time for Longer Length (sec)
4	3:46	597	0.380L
6	5:40	398	0.854L
8	7:34	298	1.520L
10	9:26	239	2.374L
12	11:20	199	3.418L
15	14:10	159	5.342L
16	15:06	149	6.078L
18	17:00	133	7.692L
21	19:50	114	10.470L
24	22:40	99	13.674L
27	25:30	88	17.306L
30	28:20	80	21.366L
33	31:10	72	25.852L
36	34:00	66	30.768L

Page 15-12, Sub-article 1520-3(A)(2)(d) Visual Inspection:

Add the following after line 29:

Visually inspect all installed gravity sewer lines and the gravity sewer lines repaired or reconnected to existing and or new manholes from the inside using approved cameras.

**Page 15-13, Sub-article 1520-3 (B) (1) Installation**

Replace paragraph 2 (Line 19) with the following:

All sewer force mains shall have automatic combination air release vacuum valves installed at all high points, as indicated on the plans, and as specified herein.

Add the following sentences:

Maintain sewer flow at all times. Use temporary diversions or pumping to maintain flow when connecting proposed sewers to existing sewers. Use engineered temporary pumping systems capable of handling full pipe flow. Use pumping systems with automatic reliable operation or constantly tended manual operation. By-pass pumping assemblies shall be installed in accordance with these Special Provisions.

All pipe shall be installed to the required lines and grades. Structures shall be installed at the design locations. The alignment of the pipe will generally be indicated by stakes parallel to the line of the pipe. The grades of the pipe will be provided by cut sheets that coincide with the provided staking. Grades shall not be provided on the survey staking. The Contractor shall be responsible for installing the pipe to proper line and grade.

Threaded PVC and cemented joints will not be permitted. The ends of push on joints shall be beveled to facilitate assembly. Pipe shall be marked by the manufacturer to indicate when the pipe is fully seated, and the gasket lubricated to prevent displacement. Care shall be exercised to ensure that the gasket remains in proper position in the bell or coupling.

All pipe installations shall be properly restrained, using either thrust blocks or approved restraint systems. The thrust blocking shall be in accordance with the drawings, and in accordance with PWC's specification and details. The approved restraint system shall be installed in accordance with the manufacturer's instructions.

**Page 15-13, Sub-article 1520-3 (B) (2) Testing**

Add the following sentences:

Where any section of a force main is provided with concrete thrust blocking for fittings, the hydrostatic test shall not be made until at least five (5) days after installation of the blocking unless otherwise approved. PWC's representative shall be present for all testing. Coordinate with PWC for disposing of the test water from the system. If blow offs are not available at the high places, taps shall be made to provide blow offs.

**Page 15-13, Add Sub-article 1520-3 (C) Additional Bypass Pumping Requirements:**

The Contractor shall provide all pumps, piping, and other equipment to accomplish this task; perform all construction; obtain all permits; pay all costs; and perform complete restoration of all

existing facilities to equal or better condition to the satisfaction of the Department. The Contractor shall be responsible for the design, installation, operation, and maintenance of the temporary bypass pumping system. The Contractor shall provide sufficient documentation to PWC to demonstrate that he, or his designated subcontractor, have the experience in the design, installation, and maintenance of temporary bypass pumping systems.

The Contractor shall be responsible for all aspects of the bypass operation, including but not limited to: providing access to install, move, and maintain the pumps in the proper position, traffic control, installation and removal of bypass equipment, pump monitoring, testing of the bypass system, re-fueling, maintenance, notification of property owners (should access to private property be necessary), wastewater and fuel spill containment, and removal and replacement of manhole cones (if necessary). The bypass system (pumps and piping) shall be monitored by Contractor personnel at all times when the bypass operation is in effect.

The Contractor shall have all materials and equipment on site to immediately respond to any emergencies or other event that could impact the bypass system (i.e., leak in the discharge piping, pump failure, flooding, etc.). The Contractor shall have sufficient staff and equipment to mobilize to repair and/or service any equipment within 1 hour of notification, 24 hours a day, seven (7) days a week. In the event of an emergency, the Contractor shall provide an immediate response and fully cooperate with PWC and the Department.

The Contractor shall install the bypass pumps, equipment, and discharge lines to minimize impacts to the property owners, residents, and environment. The Contractor shall be responsible for determining the best location for the bypass equipment, and the need for any special provisions to ensure access for the customers. Such special provisions include, but are not limited to installation of ramps, excavation and burial of the bypass lines, temporary fencing, etc. The Contractor bears all responsibility for the maintenance and restoration of any trenches, ramps, access, etc. necessary for the temporary bypass pumping operation.

The Contractor shall take appropriate steps to ensure that all pumps, piping, and hoses that carry raw sewage are protected from traffic and the public. The Contractor shall identify the proposed methods to protect the temporary bypass pumping system from traffic and the public as part of the detailed temporary bypass pumping plan. Traffic control shall be performed in accordance with the Department's traffic control plan and measures.

The bypass pumping system shall be monitored by Contractor personnel at all times (24 hours a day, 7 days a week), when the bypass operation is in effect. The Contractor's personnel shall be on-site at all times (24 hours a day, 7 days a week), and stationed at the primary bypass pumps. Depending on the location and system set-up, it may be necessary for the Contractor to station personnel at each of the various bypass pump locations. Unless otherwise approved by the Fayetteville Public Works Commission, one (1) person cannot monitor multiple bypass pump locations. All bypass pumps, regardless of their location (primary or on secondary lines), shall be equipped with an automatic dialer ( or other similar device). The Contractor personnel shall immediately respond to any issue regarding the temporary bypass pumping system. All temporary bypass piping shall be periodically monitored (patrolled from pumps to discharge), but no less



frequently than once every 12 hours. The bypass pumping equipment shall be automated and capable of functioning without the assistance of an operator.

### **Submittals**

The Contractor shall submit a detailed bypass pumping plan to PWC for approval, prior to initiating the bypass operation.

The detailed temporary bypass pumping plan shall include the following information:•

- (1) Method of monitoring the pumps to ensure proper operation, to include method of notifying personnel (PWC and Contractor) in the event of an emergency, activation of back-up pumps, etc.
- (2) Method of monitoring upstream system levels to ensure surcharging does not result in back-ups into buildings, overflows, etc.
- (3) The amount, if any, of any required surcharging.
- (4) Method to initiate back-up pumps.
- (5) Map showing general location of the pumps and bypass lines. This shall include means to maintain access to driveways, etc.
- (6) Measures to secure the bypass system (lines, pumps, etc.) from traffic, vandalism, high stream flows, etc.
- (7) Method of plugging (and securing the plug(s)) and type of plugs.
- (8) Size and location of manholes or other access points for suction and discharge piping.
- (9) Size of pipeline(s) or conveyance system(s) to be bypassed.
- (10) Number, size, material, location, and method of installation of suction piping.
- (11) Number, size, material, location, and method of installation of discharge piping.
- (12) Bypass pump sizes, capacities, and number of each size to be provided on-site, including all primary, secondary, and spare pumping units.
- (13) Calculations of static lift, friction losses, and flow velocity (pump curves showing pump operating range shall be submitted). Calculations shall be signed and sealed by a licensed Professional Engineer registered in the State of North Carolina.
- (14) Measures to protect discharge manhole(s) or structure(s) from erosion and damage due to the bypass operation.
- (15) Erosion control measures.
- (16) Emergency contact information for the personnel responsible for the pump operation.
- (17) Emergency contact information for Contractor personnel to respond in the event of an emergency.
- (18) List of available resources ( equipment, materials, personnel) and contact information for emergency response.
- (19) Method to contain potential releases of sewer flow from combination air release valves.
- (20) Contingency plan for responding to potential sewer spills caused by weather, vandalism, acts of God, etc. The plan shall include communication protocols, available resources, and the steps to be taken in the event of an emergency.

### **Coordination:**

The Contractor shall fully coordinate their temporary bypass pumping operations with PWC. It is the Contractor's responsibility to fully determine the scope and location of the temporary bypass pumping system. All coordination (to include location of the pumps and discharge lines) shall be fully discussed and agreed to prior to commencement of bypass operations.

The Contractor shall schedule a coordination meeting with PWC and other personnel (Department, Contractor, bypass sub-contractor, etc.) a minimum of three (3) business days prior to starting the temporary bypass pumping system. The purpose of this coordination meeting is to ensure that the Contractor and their sub-contractors have a good understanding of the requirements and expectations of operating the temporary bypass pumping system, discuss contingency plans (to include protocols for emergency contacts), identify location(s) of pumps, verify necessary materials (repair sleeves, containment devices, etc.) are on-site and available, and any other items necessary to ensure that PWC has confidence that the appropriate personnel can operate and maintain the temporary bypass pumping system. Should, for any reason, the Department and/or PWC deem that the Contractor and/ or their sub-contractor is not prepared to operate and maintain the temporary bypass pumping system, the temporary bypass pumping system shall not be started. The Contractor shall take all necessary steps to address any concerns to the satisfaction of PWC. Upon completion of those actions, another coordination meeting shall be held, in order for PWC to confirm that the Contractor and their sub-contractor is prepared to operate and maintain the temporary bypass pumping system. This process will be repeated until the Department and PWC are satisfied that the Contractor and their sub-contractor are prepared to operate and maintain the temporary bypass pumping system. No additional contract time will be granted for this delay.

The temporary bypass pumping system shall run for a minimum of 24 hours, or longer as deemed by PWC, prior to any activity occurring within the main(s) being bypassed.

### **Flow Control Processes:**

Where the raw sewage flow will be blocked during the Work as a result of the temporary bypass pumping operation, the Contractor shall take all necessary precautions to protect the public health. No septic conditions shall be allowed due to Contractor's operations. The sewer system (mains, manholes, laterals, etc.) shall also be protected from damage. The following occurrences shall not be allowed:

- (1) No sewage shall be allowed to back up into any homes or buildings.
- (2) No sewage shall overflow any manholes, cleanouts, or any other access to the sewers.
- (3) Users upstream of the project area shall be able to use all their water and sewer utilities without interruption or limitations.

If any of the above occur or are expected to occur, the Contractor shall take immediate action to alleviate one or all of the conditions. Additionally, the Contractor is required to observe the conditions upstream of the plug and be prepared to immediately increase bypass pumping or release the flows, as required. Any damage claims resulting from the Contractor's failure to properly maintain sewer flows shall be the Contractor's responsibility.

All sump pumps, bypass pumps, trash pumps or any other type of pump which pulls sewage or any type of material out of the sanitary sewer system shall discharge into another sanitary sewer manhole, or appropriate vehicle or container acceptable to PWC. Under no circumstances shall untreated sanitary sewer be discharged, stored, or deposited on the ground, swale, road, or open environment. The Contractor shall not allow any flow of sewage onto private property, streets, or into creeks and drainage systems. Damage due to negligence of the Contractor, including, but not limited to, flooded dwellings, damaged property, damaged driveways, etc., shall be corrected immediately by the Contractor at no additional cost to the Department or PWC.

### **Plugging and Blocking:**

In some applications, the wastewater flow may be plugged and contained within the capacity of the collection system. This shall only be done when it has been determined the system can accommodate the surcharging without any adverse impact. The Contractor has the sole responsibility for determining whether the system can accommodate surcharging. If this option is selected, the Contractor shall be responsible for continuously monitoring the system to ensure no sewer spills or overflows occur.

A sewer line plug shall be inserted into the line at a manhole upstream from the section being surveyed or repaired. The plug shall be so designed that all or any portion of the operation flows can be released. The Contractor shall secure the plug, to prevent it from being dislodged and moving downstream. Flows shall be bypassed throughout the duration of the work. Flows shall be bypassed in accordance with the approved temporary bypass pumping plan. Upon acceptance of the work by PWC, the temporary bypass pumping system shall be removed, and flows restored.

### **Pumping and Bypassing:**

The Contractor, when and where required, shall divert sewer flows for the sewer pipe rehabilitation process, cleaning, television inspection, pipe repairs, manhole replacement and/or rehabilitation, obstruction removals, or other related as required to complete the Work. The pumps and bypass lines shall be of adequate capacity and size to handle and prevent backup or overflow for all flows. The temporary bypass pumping system shall be designed to maintain the flows necessary to meet the requirements of each particular site. The Contractor shall be responsible for furnishing the necessary labor and supervision to set up, operate, and maintain the temporary bypass pumping system. A "set up" consists of the necessary pumps, conduits, and other equipment to divert the flow of sewage, from the start to finish of work performed. The temporary bypass pumping system shall include:

- (1) A minimum of one (1) redundant pump so that the temporary bypass pumping system is capable of transmitting the peak flow with the largest duty pump out of service.
- (2) Pumps shall be provided with a means of automatic control via floats or level sensing. Systems requiring manual starting and/or stopping shall not be allowed.
- (3) All equipment (primary and secondary pumps) shall be equipped in a manner to keep noise to a maximum of 65 dBA at 30 feet.
- (4) An automatic dialer (or similar) to immediately notify (in a sequential operation) Contractor and PWC personnel in the event of equipment failure. The automatic dialer

shall be set to issue notifications prior to flow level reaching critical elevations and having a spill occur. All bypass pumps (regardless of location) shall be equipped with an automatic dialer (or similar).

The temporary bypass pumping system shall be provided in such a way as to maintain access for businesses and residences. The Contractor shall be responsible for determining the best location for the bypass equipment, and the need for any special provisions to ensure access for the residents and businesses. Such special provisions include, but are not limited to installation of ramps, excavation, and burial of the bypass lines, etc. The Contractor shall use bridges over the bypass lines, temporary lines under driveways, alternate routes, or other means to accomplish this item. The bypass plan submittal shall indicate the means of maintaining access. The Contractor bears all responsibility for the maintenance of any trenches, ramps, etc. necessary for the bypass operation.

Pumps, equipment, and bypass lines shall be continuously (24 hours a day, 7 days a week) monitored by on-site Contractor personnel capable of starting, stopping, refueling, and maintaining these pumps during the Work. The temporary bypass pumping system shall be provided with an automatic dialer ( or other similar device) that will immediately notify (in a sequential operation) the Contractor and PWC in the event of equipment failure. All bypass pumps (regardless of location) shall be equipped with an automatic dialer. This automatic dialer (or similar) shall be set to issue notifications prior to flow levels reaching critical elevations and having a spill occur.

The automatic dialer shall be set to issue notifications through a sequential operation. Automatic dialers that are not set up for sequential notifications shall not be acceptable. The Contractor's personnel shall be the first to receive any notifications from the automatic dialer. The automatic dialer shall only notify the PWC personnel after all Contractor notifications have been ignored and/or not responded to. The Contractor shall properly adjust the level at which the automatic dialer initiates notification to provide adequate time for the sequential notification to occur. If the PWC personnel are notified by the automatic dialer, the PWC personnel shall assume that a spill is occurring or is imminent and respond accordingly. The Contractor shall be responsible for all costs for the PWC to mobilize and respond to the notification, regardless if a spill occurred or not.

In some applications, it may be necessary to surcharge the system in order to ensure proper pump operation. This shall only be done when it has been determined the system can accommodate the surcharging without any adverse impact. The Contractor has the sole responsibility for determining whether the system can accommodate surcharging. In the event surcharging is necessary, the Contractor shall be responsible for continuously monitoring the system to ensure no sewer spills occur.

All bypass piping shall successfully pass a hydrostatic test prior to bypassing the sewer flows. The hydrostatic test pressure shall be no less than the expected discharge pressures and shall be held for a minimum of one (1) hour. All testing shall be observed by PWC. Testing shall be coordinated with PWC a minimum of 48 hours in advance.

**Spill Response:**

The Contractor shall not discharge or pump any sewage, solids, or debris on the ground, streets, storm water system, ditches, or streams. Any sewage spills shall be immediately reported to the PWC's Construction Department, (910) 223-4716, PWC Project Coordinator & the Department. After normal business hours, the Contractor shall contact the Fayetteville Public Works Commission Dispatch Center, (910) 678-7400 or (910) 323-0178. The Contractor shall take complete responsibility for all costs related to the clean-up of the spill, including any fines issued by the North Carolina Department of Environmental Quality (NC DEQ).

In the event that raw sewage (in any quantity) is spilled, discharged, leaked, or otherwise deposited in the open environment, due to the Contractor's work, the Contractor is responsible for any cleanup of solids and disinfection of the area affected. This work will be performed at the Contractor's expense with no additional cost to the Department and/or Fayetteville Public Works Commission. The Contractor is also responsible for complying with any and all regulatory requirements in regard to the size spill with no additional cost to the Department and/or Fayetteville Public Works Commission. The Contractor shall cooperate fully with the Fayetteville Public Works Commission and the applicable State agencies in responding to and cleaning up the spill. Any work completed by the Fayetteville Public Works Commission in responding to a spill caused by the Contractor's operations shall be billed to the Contractor.

Where sewage has backed up into a property due to any aspect of the Contractor's operation, the Contractor shall immediately notify PWC and the Department inspect the property with the Department and PWC and agree on remedial measures. The Contractor shall be responsible for all cleaning, repair and/or replacement of damaged property, temporary relocation of all occupants of the affected properties, if required, all to the satisfaction of the property owner. These actions shall be undertaken immediately upon learning of the backup. Cleaning shall be performed by firms specializing in this type of work. All costs associated with the cleaning, repair, replacement of damages, occupant accommodations, insurance and spill remediation shall be borne by the Contractor. All remediation measures required as part of a spill response are part of acceptance of the project, and final payment shall not be made until such time all required measures are addressed and approved by the appropriate regulatory agency.

### **Page 15-13, Sub-article 1520-4, Measurement and Payment**

Add the following paragraphs to each respective item:

For Sanitary Gravity Sewer, removal, and disposal of existing main shall be incidental to the installation of the new pipe and no separate payment will be made.

Sewer Service Line will be paid per linear foot and by size (four (4) inch or six (6) inch). All fittings will be incidental to Sewer Service Line. Removal and disposal of existing sewer service lateral shall be incidental to the installation of the new sewer service lateral and no separate payment will be made.

### **1525-UTILITY MANHOLES**

### **Page 15-14, ARTICLE 1525-2 MATERIALS**

Add the following sentences to the end of the section paragraph (Line 20):

The frame and cover shall be manufactured by the same manufacturer. All castings shall be in accordance with PWC's standard detail. Any defective castings shall be removed and replaced.

In unpaved areas, cam-lock ring and cover shall be used. Camlock bolt head shall be compatible with PWC's standard tool for turning camlock mechanism. The contractor shall provide one tool to open the cam locks at the end of the project. Camlock ring and covers shall be installed as indicated on the drawings, in accordance with the PWC standard details.

**Page 15-14, Add Sub-article 1525-2 (A) Precast Concrete Sanitary Sewer Manholes**

All manholes shall be constructed to these Special Provisions and PWC Standard Details. Installation shall be in accordance with ASTM C-891 and these Special Provisions. An eccentric cone shall be utilized on all manholes, unless otherwise approved by PWC.

Manhole steps shall be placed in all manholes and shall be steel reinforced( $\frac{1}{2}$ " grade 60) copolymer polypropylene plastic steps in accordance with ASTM C-478 for material and design. The steps shall be made with serrated treads and wide enough to stand on with both feet.

All reinforced concrete precast manholes shall include a liquid anti-microbial admixture to render the concrete uninhabitable for bacterial growth. The admixture shall be included in the fabrication of the manhole by an approved concrete precast manhole manufacturer. Coatings applied to the interior walls of the manhole shall not be acceptable. The anti-microbial admixture shall be approved by PWC. A color identifier shall be applied to the interior of each concrete piece fabricated with the anti-microbial admixture. Each piece shall also be plainly stenciled with the name of the anti-microbial admixture on the exterior of each.

Further, all field mixed mortar, utilized in concrete precast manholes, shall include the same anti-microbial admixture. Any defects shall be cause for the replacement and correction of such defect as directed by PWC, at no additional expense.

Any special linings and coatings that are specified for a manhole and installed at the production facility, in the field, or during repairs, shall be applied in accordance with the applicable special coatings specification and the manufacturer's specifications for that material.

**Page 15-14, Add Sub-article 1525-2 (B) Special Coatings, Anti-Microbial Admixture**

The liquid anti-microbial admixture shall be used in accordance with the manufacturer's recommendations. The amount of the admixture shall be included in the total water content of the concrete or mortar mix design. The admixture shall be added to the concrete or mortar mix water, to ensure even distribution of the admixture throughout the concrete or mortar mix. When properly prepared, the anti-microbial admixture shall render the concrete or mortar uninhabitable for bacterial growth.

The anti-microbial admixture shall be approved by PWC. The cost of the admixture shall be included in the fabrication of all sewer manhole sections.

**Page 15-14, Add Sub-article 1525-2 ( C) Sanitary Sewer Manhole Vents**

Sewer manhole vent shall be fabricated from three (3) inch Schedule 40 aluminum pipe. Vent shall be threaded into manhole lid. Manhole lid shall be drilled and tapped to accommodate three (3) inch diameter threaded pipe. Minimum height shall be four (4) feet to crest of vent. Vent shall extend to two (2) feet above the 100-year flood elevation where manholes are located in a FEMA flood hazard zone. Vent opening shall be protected with stainless-steel screen. Vents shall be placed every 1,000 feet or as directed by PWC.

**Page 15-14, Sub-article 1525-2, Materials****Page 15-14, Add Sub-article 1525-2 (D) Fittings and Connections**

Pipe connections to a manhole shall be by gasketed flexible watertight connections.

A watertight, flexible pipe-to-manhole connector shall be used on all pipe to manhole connections, for both new and existing manholes and pipes, unless otherwise specifically authorized in writing by PWC.

The internal expansion sleeve shall be comprised of Series 300 non-magnetic stainless-steel. The external compression take-up clamps shall also be Series 300 non-magnetic stainless-steel. No welds shall be utilized in the sleeve and clamp construction.

**Page 15-15 ARTICLE 1525-3 CONSTRUCTION METHODS**

Page 15-15, Line 1, Replace paragraph with:

Provide an inside drop assembly on manholes for sewer pipes entering with 2.5 feet or more vertical drop. Inside drop assemblies shall be used for connections to existing manholes when the drop exceeds 2.5 feet. New installation, the manhole diameter shall be 5 feet or larger. Provide a pipe slide where vertical separation between inverts is less than 2.5 feet or as directed by PWC.

Page 15-15, Line 4, Replace paragraph with:

In all sewer manholes, provide steps spaced 16 inches on center. Install steps in line with the effluent opening unless otherwise specified.

Page 15-15, Line 6, Replace paragraph with:

The manhole invert shall be constructed of brick and mortar, in accordance with PWC standard detail. Precast inverts are not allowed. The invert channel shall be smooth and semicircular in shape conforming to the inside of the connecting sewer section. Changes in direction of flow shall be made with a smooth curve as large as a radius as the size of the manhole will permit without a decrease in flow velocity. Changes in size and grade of the channel shall be made gradually and evenly. The invert channel walls shall be constructed to three quarters (3/4) of the height of the crown of the outlet sewer and in such a manner not to obstruct maintenance, inspection, or flow in the sewers. The inverts shall have a minimum slope of 1% across the bottom of the manhole. A

shelf shall be provided on each side of any manhole invert channel. Inverts in manholes with standing water will not be acceptable. The shelf shall be sloped not less than 1: 12 (min) and no more than 2: 12 (max). When connecting to an existing manhole, the bottom of the boot for the new sewer main or lateral shall be set 1 inch above existing shelf unless otherwise indicated.

Page 15-15, Line 12, Replace Table 1525-1 with:

<b>TABLE 1525-1 MANHOLE CONSTRUCTION</b>		
<b>Location</b>	<b>Top height above finished grade</b>	<b>Ring and Cover Type</b>
Roadway pavement, Driveways, Sidewalks, Parking lots	Flush ± ¼” with concrete collar	Standard Traffic Area Manhole Ring and Cover (H-20 Rated)
Vehicle Recovery Area	Flush ± 3”	Standard Traffic Area Manhole Ring and Cover with Wiper Gasket and Cam Lock
Manicured Areas	Flush to +2”	Standard non-Traffic Area Manhole Ring and Cover with Wiper Gasket and Cam Lock
Flood Zones less than 3 ft above finished grade	Minimum 18” Above Ground with Vent Extending to 2 feet above 100-year Flood Elevation	Standard non-Traffic Area Manhole Ring and Cover with Wiper Gasket and Cam Lock
Flood Zones greater than 3 ft above finished grade	Minimum 18” Above Ground with Vent Extending to 2 feet above 100-year Flood Elevation	Standard non-Traffic Area Manhole Ring and Cover with Wiper Gasket and Cam Lock
Outfall Areas outside of Flood Zones	Minimum 18” Above Ground	Standard non-Traffic Area Manhole Ring and Cover with Wiper Gasket and Cam Lock

Add additional provisions:

The manhole size shall be in accordance with the following table, unless otherwise specified:

Pipe Size (inches)	Manhole Diameter (inches)**
24 and less	48
27 to 36	60*
42	72

\*Where one main line or multiple lateral interior drop structures are required, use 60-inch-diameter as required in PWC's standard details.



\* \* Where multiple connections or acute angles are required, larger diameter manhole may be required as indicated on the Drawings.

**Page 15-15, Sub-article 1525-3 (B), Installation of Precast Units**

Add the following paragraph:

All exterior manhole section joints shall be sealed with an external rubber sleeve. The sleeve shall be made of stretchable, self-shrinking rubber, with a minimum thickness of 30 mils. The back side of each wrap shall be coated with a cross-linked reinforced butyl adhesive. The butyl adhesive shall be a non-hardening sealant, with a minimum thickness of 30 mils.

Page 15-15, Sub-article 1525-3 (C) Fittings and Connections

Page 15-15, Line 33-Add the following after the last paragraph:

Installation of the connector shall be performed using a calibrated installation tool furnished by the connector manufacturer. Installation shall require no re-tightening after the initial installation. Installation shall be done in accordance with the manufacturer's instructions.

The external compression take-up clamps shall be installed in accordance with the manufacturer's instructions.

The Contractor shall use the proper size connector in accordance with the connector manufacturer's recommendations.

All dead-end pipe stubs shall be restrained in accordance with ASTM C-923.

**Page 15-16, Sub-article 1525-3 (D) Testing**

Add the following:

All precast sanitary sewer manholes installed by the Contractor shall be vacuum tested for leakage. This test shall be done in accordance with ASTM C-1244 and in the presence of PWC. Provide all the necessary labor, materials, equipment, testing apparatus, and all other incidentals necessary to complete the vacuum test. All testing equipment used shall be approved for use in vacuum testing manholes.

Each manhole shall be tested after assembly. All lift holes shall be plugged with an approved non-shrink grout. All lines, including laterals, entering the manhole shall be temporarily plugged. Ensure that the pipes and plugs are secure in place to prevent them being drawn into the manhole. The test head shall be placed directly on top of the concrete surface of the manhole following the manufacturer's recommendations, rather than to the cast iron seating ring.

Manholes may be tested either prior to backfill or post backfill at the contractor's option. For pre-backfill testing, a vacuum of 10 inches of Mercury (inches Hg) shall be drawn on the manhole, the valve on the vacuum line of the test head closed, and the vacuum pump shut off. The time shall be

measured for the vacuum to drop to 9 inches of Mercury (inches Hg). The manhole is acceptable if the time for the vacuum reading to drop from 10 inches of Mercury to 9 inches of Mercury meets

Diameter of Manhole			
Manhole Depth	4' Diameter	5' Diameter	6' Diameter
10' or less	25 sec	33 sec	41 sec
11' to 15'	38 sec	49 sec	62 sec
16' to 20'	50 sec	65 sec	81 sec
21' to 25'	62 sec	82 sec	101 sec
25' to 30'	74 sec	98 sec	121 sec

or exceeds the values indicated below:

Vacuum testing backfilled manholes is not recommended in the presence of groundwater. Vacuum testing a backfilled manhole that is subjected to hydrostatic pressure may exceed the design limits of the flexible connectors and could lead to failure of the structure, joints, and/or connectors. Where groundwater is present a reduction in the vacuum pressure applied to the manhole will be required. The vacuum shall be reduced by 1 inch of Mercury for every 1 foot of hydrostatic head between 12 feet and 21 feet. A vacuum test should not be performed when the hydrostatic head exceeds 22 feet. See the chart below:

Hydrostatic Head (ft)*	12	13	14	15	16	17	18	19	20	21	22
Vacuum Pressure (in Hg)	10	9	8	7	6	5	4	3	2	1	**

\*Hydrostatic head above the critical connector (critical connector is bottom most flexible connector)

\*\*Do not perform vacuum test

If the manhole fails the initial test, the manhole shall be repaired by an approved method until a satisfactory test is obtained. All repair methods shall be approved by PWC prior to being used. Retesting shall be performed until a satisfactory test is accomplished.

**SECTION 1530 -ABANDON OR REMOVE UTILITIES****Page 15-16, ARTICLE 1530-3 CONSTRUCTION METHODS****Page 15-16, Sub-article 1530-3 (A) Abandoning Pipe**

Add the following paragraphs:

Perform kill-outs of existing mains to be abandoned as designated on the Drawings. Kill-outs shall consist of the following requirements and/or as directed by PWC.

- (1) Kill out shall be done a minimum of five (5) feet from any fitting on the existing water main that is to remain in service.
- (2) Ductile iron pipe stiff knee shall be four (4) inch diameter for mains 12-inches or less. Utilize eight (8) inch ductile iron pipe or larger for mains larger than 12-inches. Minimum length of five (5) feet of stiff knee shall be provided. Stiff knee shall be encased in concrete. Concrete shall cover the abandoned pipe, but it shall not come in contact with the active water main or any fittings on the active water main. Place blocks rated as the same compressive strength as the concrete under the stiff knee to provide support during concrete placement.
- (3) On the active water main side of the stiff knee, provide full body mechanical joint sleeve with restraining gland and restraining plug or cap.
- (4) On the abandoned water main side, provide minimum one-quarter (1/4) inch steel plate or ductile iron cap or plug.
- (5) Coordinate outages with PWC and other work to minimize number of planned outages.
- (6) Abandoned pipe shall be grout filled or removed in accordance with Section 1530.

Remove valves, or close valves and remove the top of the valve box to an elevation two (2) feet below the roadway subgrade or finished grade and backfill or as directed by PWC.

**Page 15-17, ARTICLE 1530-4 MEASUREMENT AND PAYMENT**

Add the following sentence to the first paragraph:

Kill out of existing water mains to be abandoned shall be incidental to the other work and will not be measured and paid.

**SECTION 1540-ENCASEMENT****Page 15-18, ARTICLE 1540-2 MATERIALS**

Page 15-18 Add Sub-Article 1540-2 (A) Encasements for Railroad Crossings

Encasement wall thickness for the railroad crossing shall comply with the following chart unless indicated otherwise on the Drawings or defined by PWC, the Department or Railroad.

CARRIER PIPE (dia, in inches)	MIN CASING SIZE (inches)	WALL THICKNESS (inches)	RAILROAD WALL THICKNESS (inches)
4	10	0.188	0.188
6	12	0.250	0.281
8	16	0.250	0.281
12	24	0.250	0.375
16	30	0.312	0.469
18	30	0.312	0.469
24	36	0.375	0.532
30	42	0.500	0.625
36	48	0.500	0.688

The Contractor may substitute larger size casing pipe (particularly for sewer mains where grade and alignment are critical) with the proper wall thickness. All additional costs shall be included in the cost of the encasement. Furthermore, the Contractor will be responsible for all engineering costs to update the 100-year design service life for the larger encasement at their expense.

**Page 15-18 Add Sub-Article 1540-2 (A) Encasements for Water and Sewer Mains**

The carrier pipe installed for water or force main applications, shall be CL 50 ductile iron factory restrained joint pipe.

The material for the gravity sanitary sewer carrier pipe shall be restrained joint ductile iron unless noted on the Drawings or as directed by PWC to be C-900 PVC (DR 18). Where ductile iron is called out, gravity sewer pipe shall be CL 50 ductile iron restrained joint pipe. All ductile iron carrier pipes in sewer service shall have the appropriate lining and coating. Use of restraining gaskets (i.e., field-lock gaskets) is an acceptable means of restraint for gravity sewer mains. Use of iron MJ restraint retaining glands are not approved for restraint within casings.

All ductile iron pipe pressure pipe (regardless of diameter) within casings shall be factory restrained, in accordance with these specifications and as indicated on the drawings. The use of mechanical restraints shall not be used on pipe within casings for pressure pipe.

Annular space between walls and sleeves shall be filled with an approved cement mortar. Annular space between pipe and sleeves shall be filled with mastic.

Add the following paragraphs for specifying the carrier pipe brace or spider assembly for ductile iron carrier pipes:

Provide carbon steel carrier pipe brace with the band being made from 12-gauge minimum thickness with 4-inch width and riser being made from eight (8) gauge minimum thickness. Runners shall be minimum 2 inches wide.

Add the following paragraphs for specifying the carrier pipe brace or spider assembly for 8-inch C900 PVC carrier pipe.

Provide carbon steel carrier pipe brace with the band being made from fourteen (14) gauge minimum thickness with 8-inch width and riser being made from fourteen (14) gauge minimum thickness. Runners shall be minimum two (2) inch width with UHMW Polymer coating. Legs shall be minimum fourteen (14) gauge thickness with six(6)-inch width.

### **Page 15-18, ARTICLE 1540-3 CONSTRUCTION METHODS**

#### **Page 15-18, Sub-article 1540-3. (C) Encasements for Future Use**

Add the following paragraph:

Mark encasements for future use with a manufactured three (3) sided fiberglass utility marker

(color green for sewer and blue for water). Marker shall be anchored in the ground using U-channel Post minimum of two (2) feet in depth. Place marker at the right of way or at the ends of the encasements if encasements extend beyond the right of way.

#### **Page 15-18, Sub-article 1540-3 (D), Carrier Pipe Installation**

Add the following sentences to the first paragraph for ductile iron carrier pipes:

Minimum spacing for carrier pipe brace or spider assemblies shall be at 3 feet prior to and 3 feet after each joint of ductile iron carrier pipe in accordance with PWC's standard detail.-Fasten brace or spider to pipe with heavy duty studs, nuts, and washers.

### **SECTION 1550-TRENCHLESS INSTALLATION OF UTILITIES**

#### **Page 15-20, ARTICLE 1550-3 CONSTRUCTION METHODS**

##### **Page 15-20, Sub-article 1550-3 (B) Design**

Add the following sentences to the last paragraph:

For boring and tunneling operations, the certified calculations shall include a geotechnical analysis to confirm the selected method will not result in road settlement or upheaval, a road movement monitoring plan and remediation plan should the work result in settlement or upheaval. For drilling operations, appropriate calculations shall be provided to evaluate hydraulic fracturing and to develop a Fraction Mitigation Contingency Plan.

#### **Page 15-20, ARTICLE 1550-4 MEASUREMENT AND PAYMENT**

**Page 15-20, Sub-article 1550-4 (A) Bore and Jack**

Add the following paragraphs:

Locate all existing utilities in the proposed location of the jack and bore.

**Pilot Tube Guided Auger Bore and Jack**

The Pilot Tube Guided Auger Bore and Jack system shall utilize a two or three phase system as described below:

**1) Three Pass System**

- A.** Phase 1 - A rigid steel pilot tube in approximately one-meter lengths shall be installed through the ground from the drive shaft to the receiver shaft by earth displacement with the jacking frame. The alignment of the pilot tube shall be established with a theodolite mounted at the rear of the drive shaft and accurately set to the desired line and grade. The theodolite shall view a lighted target in the lead or steering pilot tube. A camera shall be fitted to the theodolite and shall transmit the image of the crosshair and the target onto a monitor screen to be viewed in the drive shaft by the operator. As the operator advances the pilot tube through the earth the center of the target will drift from the crosshair as a result of the biased or slanted leading tip of the pilot tube. The operator shall rotate the pilot tube as required to orient the slanted steering tip toward the crosshair and continue to advance the pilot tube until it reaches the receiver shaft.
- B.** Phase 2 -An enlargement casing with an outside diameter up to one and a half (1 ½) inches larger than the product pipe shall be rigidly connected to the final pilot tube and advanced into the earth behind the pilot tube. An auger shall be used inside the enlargement casing to remove the material being excavated. The auger shall be contained inside the limits of the enlargement casing as it progresses along the proposed alignment. A train of temporary steel casings with an outside diameter very similar to the enlargement casing and used to move the enlargement casing from the drive shaft to the receiver shaft. The enlargement casing will cut a bore hole from the drive shaft to the receiver shaft and the temporary casings will case the hole as it is cut. Each temporary casing shall be fitted with an internal auger to transport the excavated material to the drive shaft where it shall be removed from the shaft and disposed of at an approved location. The pilot tubes shall be recovered in the receiver shaft as the temporary casings are installed.
- C.** Phase 3-The product pipe shall then be installed directly behind the final temporary casing pipe with the jacking frame. The casing pipes and augers shall be recovered in the receiver shaft as the product pipe is installed.

**2) Two Pass System**

- A.** Phase 1 - The pilot tube shall be installed in the same manner described in Phase 1 of the Three Pass System.

- B.** Phase 2 - The enlargement casing shall be installed in the same manner described in Phase 2 of the Three-Phase System. Each product pipe shall be fitted with an internal protective-casing pipe to house the auger and prevent damage to product pipe. The product pipe shall be installed directly behind the enlargement casing with the internal casing rigidly connected to the auger chamber of the enlargement casing. The internal casing shall be manufactured such that the excavated material does not leak excessively into the product pipe. The internal casing shall be fitted with a protective shoe to protect the product pipe from damage and to support the casing and auger at the centerline of the pipe.
- C.** Phase 3 - The product pipe shall be advanced along the proposed alignment with the jacking frame thus progressing the enlargement casing from the drive shaft to the receiver shaft with the pilot tubes being recovered in the receiver shaft. The excavated material shall be funneled into and conveyed through the internal casing to the drive shaft where it shall be removed from the shaft and disposed of at an approved location. Upon reaching the receiver shaft the enlargement casing shall be removed and the internal casings and augers retracted and recovered at the drive shaft.

**Page 15-21, Sub-article 1550-4 (B), Directional Drilling**

Add the following paragraph:

At the horizontal directional drill locations and prior to drilling, remove the upper 18 inches of the bearing soil and place a geotextile (Mirafi 140 N or equivalent) over the entire bearing location. Backfill the excavation with clean, washed, NCDOT #57 stone to the bearing level of the working platform. The thickness of the NCDOT #57 stone should not exceed two feet in thickness before being compacted with a vibratory plate compactor. Have a qualified geotechnical engineer provide written approval of the working platform bearing grades once final locations are selected and prior to starting the advancement of the directional drills.

**Page 15-21, Sub-article 1550-4 (C), Tunneling**

Add the following paragraph:

The Contractor shall locate all existing utilities in the proposed location of the jack and bore.

**Page 15-21, Sub-article 1550-4 (D), Pipe Ramming**

Add the following paragraph:

The Contractor shall locate all existing utilities in the proposed location of the jack and bore.

PROJECT SPECIAL PROVISIONS

Utilities by Others



General:

The following utility companies have facilities that will be in conflict with the construction of this project:

- A) Lumbee River EMC -- Electric
- B) Spectrum – Communications
- C) Piedmont Natural Gas – Gas
- D) Brightspeed (Formerly Lumen) - Communications
- E) Metronet – Communications
- F) AT&T Transmission – Communications

Contractor will contact Division 6 Utilities Unit with any questions or concerns about the Utilities Owners relocations.

Rick Handlin  
Division 6 Utility Engineer  
Office # 910-364-0834  
[rhandlin@ncdot.gov](mailto:rhandlin@ncdot.gov)

John Walters  
Division 6 Utility Coordinator  
Cell # 910-495-5848  
[ext-jewalters@ncdot.gov](mailto:ext-jewalters@ncdot.gov)



PROJECT SPECIAL PROVISIONS

Utilities by Others

Utilities Requiring Adjustment:

The conflicting facilities of these concerns will be adjusted prior to the Date of Availability (DOA), unless otherwise noted and are therefore listed in these special provisions for the benefit of the Contractor. All utility work listed herein will be done by the utility owners. All utilities are shown on the plans from the best available information.

The Contractor's attention is directed to Article 105-8 of the Standard Specifications.

**Utilities Requiring Adjustment:**

Utility relocations are shown on the Utilities by Others Plans

A. Lumbee River EMC – Electric

1. Lumbee River EMC is Complete.

B. Spectrum - Communications

1. Spectrum will be Complete by DOA.

C. Piedmont Natural Gas – Gas

1. PNG will be complete by DOA.

D. Brightspeed (Formerly Lumen) – Communications

1. Brightspeed will be complete by DOA.

E. Metronet – Communications

1. Metronet will be complete by DOA.

F. AT&T Transmission – Communications

1. AT&T is complete.

**Project Special Provisions  
Erosion Control**

**STABILIZATION REQUIREMENTS:**

(4-30-2019)

Stabilization for this project shall comply with the time frame guidelines as specified by the NCG-010000 general construction permit effective April 1, 2019 issued by the North Carolina Department of Environmental Quality Division of Water Resources. Temporary or permanent ground cover stabilization shall occur within 7 calendar days from the last land-disturbing activity, with the following exceptions in which temporary or permanent ground cover shall be provided in 14 calendar days from the last land-disturbing activity:

- Slopes between 2:1 and 3:1, with a slope length of 10 ft. or less
- Slopes 3:1 or flatter, with a slope of length of 50 ft. or less
- Slopes 4:1 or flatter

The stabilization timeframe for High Quality Water (HQW) Zones shall be 7 calendar days with no exceptions for slope grades or lengths. High Quality Water Zones (HQW) Zones are defined by North Carolina Administrative Code 15A NCAC 04A.0105 (25). Temporary and permanent ground cover stabilization shall be achieved in accordance with the provisions in this contract and as directed.

**SEEDING AND MULCHING:**

**(East)**

The kinds of seed and fertilizer, and the rates of application of seed, fertilizer, and limestone, shall be as stated below. During periods of overlapping dates, the kind of seed to be used shall be determined. All rates are in pounds per acre.

All Roadway Areas

<b>March 1 - August 31</b>		<b>September 1 - February 28</b>	
50#	Tall Fescue	50#	Tall Fescue
10#	Centipede	10#	Centipede
25#	Bermudagrass (hulled)	35#	Bermudagrass (unhulled)
500#	Fertilizer	500#	Fertilizer
4000#	Limestone	4000#	Limestone

Waste and Borrow Locations

<b>March 1 – August 31</b>		<b>September 1 - February 28</b>	
75#	Tall Fescue	75#	Tall Fescue
25#	Bermudagrass (hulled)	35#	Bermudagrass (unhulled)
500#	Fertilizer	500#	Fertilizer
4000#	Limestone	4000#	Limestone

Note: 50# of Bahiagrass may be substituted for either Centipede or Bermudagrass only upon Engineer's request.

### Approved Tall Fescue Cultivars

06 Dust	Escalade	Justice	Serengeti
2 <sup>nd</sup> Millennium	Essential	Kalahari	Shelby
3 <sup>rd</sup> Millennium	Evergreen 2	Kitty Hawk 2000	Sheridan
Apache III	Falcon IV	Legitimate	Signia
Avenger	Falcon NG	Lexington	Silver Hawk
Barlexas	Falcon V	LSD	Sliverstar
Barlexas II	Faith	Magellan	Shenandoah Elite
Bar Fa	Fat Cat	Matador	Sidewinder
Barrera	Festnova	Millennium SRP	Skyline
Barrington	Fidelity	Monet	Solara
Barrobusto	Finelawn Elite	Mustang 4	Southern Choice II
Barvado	Finelawn Xpress	Ninja 2	Speedway
Biltmore	Finesse II	Ol' Glory	Spyder LS
Bingo	Firebird	Olympic Gold	Sunset Gold
Bizem	Firecracker LS	Padre	Taccoa
Blackwatch	Firenza	Patagonia	Tanzania
Blade Runner II	Five Point	Pedigree	Trio
Bonsai	Focus	Picasso	Tahoe II
Braveheart	Forte	Piedmont	Talladega
Bravo	Garrison	Plantation	Tarheel
Bullseye	Gazelle II	Proseeds 5301	Terrano
Cannavaro	Gold Medallion	Prospect	Titan ltd
Catalyst	Grande 3	Pure Gold	Titanium LS
Cayenne	Greenbrooks	Quest	Tracer
Cessane Rz	Greenkeeper	Raptor II	Traverse SRP
Chipper	Gremlin	Rebel Exeda	Tulsa Time
Cochise IV	Greystone	Rebel Sentry	Turbo
Constitution	Guardian 21	Rebel IV	Turbo RZ
Corgi	Guardian 41	Regiment II	Tuxedo RZ
Corona	Hemi	Regenerate	Ultimate
Coyote	Honky Tonk	Rendition	Venture
Darlington	Hot Rod	Rhambler 2 SRP	Umbrella
Davinci	Hunter	Rembrandt	Van Gogh
Desire	Inferno	Reunion	Watchdog
Dominion	Innovator	Riverside	Wolfpack II
Dynamic	Integrity	RNP	Xtremegreen
Dynasty	Jaguar 3	Rocket	
Endeavor	Jamboree	Scorpion	

On cut and fill slopes 2:1 or steeper Centipede shall be applied at the rate of 5 pounds per acre and add 20# of Sericea Lespedeza from January 1 - December 31.

Fertilizer shall be 10-20-20 analysis. A different analysis of fertilizer may be used provided the 1-2-2 ratio is maintained and the rate of application adjusted to provide the same amount of plant food as a 10-20-20 analysis and as directed.

**Native Grass Seeding and Mulching (East)**

Native Grass Seeding and Mulching shall be performed on the disturbed areas of wetlands and riparian areas, and adjacent to Stream Relocation construction within a 50 foot zone on both sides of the stream or depression, measured from top of stream bank or center of depression. The stream bank of the stream relocation shall be seeded by a method that does not alter the typical cross section of the stream bank. Native Grass Seeding and Mulching shall also be performed in the permanent soil reinforcement mat section of preformed scour holes, and in other areas as directed.

The kinds of seed and fertilizer, and the rates of application of seed, fertilizer, and limestone, shall be as stated below. During periods of overlapping dates, the kind of seed to be used shall be determined. All rates are in pounds per acre.

<b>March 1 - August 31</b>		<b>September 1 - February 28</b>	
18#	Creeping Red Fescue	18#	Creeping Red Fescue
6#	Indiangrass	6#	Indiangrass
8#	Little Bluestem	8#	Little Bluestem
4#	Switchgrass	4#	Switchgrass
25#	Browntop Millet	35#	Rye Grain
500#	Fertilizer	500#	Fertilizer
4000#	Limestone	4000#	Limestone

Approved Creeping Red Fescue Cultivars:

- Aberdeen
- Boreal
- Epic
- Cindy Lou

Fertilizer shall be 10-20-20 analysis. A different analysis of fertilizer may be used provided the 1-2-2 ratio is maintained and the rate of application adjusted to provide the same amount of plant food as a 10-20-20 analysis and as directed.

Native Grass Seeding and Mulching shall be performed in accordance with Section 1660 of the *Standard Specifications* and vegetative cover sufficient to restrain erosion shall be installed immediately following grade establishment.

**Measurement and Payment**

Native Grass *Seeding and Mulching* will be measured and paid for in accordance with Article 1660-8 of the *Standard Specifications*.

All areas seeded and mulched shall be tacked with asphalt. Crimping of straw in lieu of asphalt tack shall not be allowed on this project.

**CRIMPING STRAW MULCH:**

Crimping shall be required on this project adjacent to any section of roadway where traffic is to be maintained or allowed during construction. In areas within six feet of the edge of pavement, straw is to be applied and then crimped. After the crimping operation is complete, an additional application of straw shall be applied and immediately tacked with a sufficient amount of undiluted emulsified asphalt.

Straw mulch shall be of sufficient length and quality to withstand the crimping operation.

Crimping equipment including power source shall be subject to the approval of the Engineer providing that maximum spacing of crimper blades shall not exceed 8".

**TEMPORARY SEEDING:**

Fertilizer shall be the same analysis as specified for *Seeding and Mulching* and applied at the rate of 400 pounds and seeded at the rate of 50 pounds per acre. Sweet Sudan Grass, German Millet or Browntop Millet shall be used in summer months and Rye Grain during the remainder of the year. The Engineer will determine the exact dates for using each kind of seed.

**FERTILIZER TOPDRESSING:**

Fertilizer used for topdressing on all roadway areas except slopes 2:1 and steeper shall be 10-20-20 grade and shall be applied at the rate of 500 pounds per acre. A different analysis of fertilizer may be used provided the 1-2-2 ratio is maintained and the rate of application adjusted to provide the same amount of plant food as 10-20-20 analysis and as directed.

Fertilizer used for topdressing on slopes 2:1 and steeper and waste and borrow areas shall be 16-8-8 grade and shall be applied at the rate of 500 pounds per acre. A different analysis of fertilizer may be used provided the 2-1-1 ratio is maintained and the rate of application adjusted to provide the same amount of plant food as 16-8-8 analysis and as directed.

**SUPPLEMENTAL SEEDING:**

The kinds of seed and proportions shall be the same as specified for *Seeding and Mulching*, with the exception that no centipede seed will be used in the seed mix for supplemental seeding. The rate of application for supplemental seeding may vary from 25# to 75# per acre. The actual rate per acre will be determined prior to the time of topdressing and the Contractor will be notified in writing of the rate per acre, total quantity needed, and areas on which to apply the supplemental seed. Minimum tillage equipment, consisting of a sod seeder shall be used for incorporating seed into the soil as to prevent disturbance of existing vegetation. A clodbuster (ball and chain) may be used where degree of slope prevents the use of a sod seeder.

**MOWING:**

The minimum mowing height on this project shall be 4 inches.

**LAWN TYPE APPEARANCE:**

All areas adjacent to lawns must be hand finished as directed to give a lawn type appearance. Remove all trash, debris, and stones ¾" and larger in diameter or other obstructions that could interfere with providing a smooth lawn type appearance. These areas shall be reseeded to match their original vegetative conditions, unless directed otherwise by the Field Operations Engineer.

**MINIMIZE REMOVAL OF VEGETATION:**

The Contractor shall minimize removal of vegetation within project limits to the maximum extent practicable. Vegetation along stream banks and adjacent to other jurisdictional resources outside the construction limits shall only be removed upon approval of Engineer. No additional payment will be made for this minimization work.

**CONSTRUCTION MATERIALS MANAGEMENT**

(3-19-19) (rev. 04-27-20)

**Description**

The requirements set forth shall be adhered to in order to meet the applicable materials handling requirements of the NCG010000 permit. Structural controls installed to manage construction materials stored or used on site shall be shown on the E&SC Plan. Requirements for handling materials on construction sites shall be as follows:

**Polyacrylamides (PAMS) and Flocculants**

Polyacrylamides (PAMS) and flocculants shall be stored in leak-proof containers that are kept under storm-resistant cover or surrounded by secondary containment structures designed to protect adjacent surface waters. PAMS or other flocculants used shall be selected from the NC DWR List of Approved PAMS/Flocculants. The concentration of PAMS and other flocculants used shall not exceed those specified in the NC DWR List of Approved PAMS/Flocculants and in accordance with the manufacturer's instructions. The NC DWR List of Approved PAMS/Flocculants is available at:

[https://files.nc.gov/ncdeq/Water+Quality/Environmental+Sciences/ATU/PAM8\\_30\\_18.pdf](https://files.nc.gov/ncdeq/Water+Quality/Environmental+Sciences/ATU/PAM8_30_18.pdf)

**Equipment Fluids**

Fuels, lubricants, coolants, and hydraulic fluids, and other petroleum products shall be handled and disposed of in a manner so as not to enter surface or ground waters and in accordance with applicable state and federal regulations. Equipment used on the site must be operated and maintained properly to prevent discharge of fluids. Equipment, vehicle, and other wash waters

shall not be discharged into E&SC basins or other E&SC devices. Alternative controls should be provided such that there is no discharge of soaps, solvents, or detergents.

### **Waste Materials**

Construction materials and land clearing waste shall be disposed of in accordance with North Carolina General Statutes, Chapter 130A, Article 9 - Solid Waste Management, and rules governing the disposal of solid waste (15A NCAC 13B). Areas dedicated for managing construction material and land clearing waste shall be at least 50 feet away from storm drain inlets and surface waters unless it can be shown that no other alternatives are reasonably available. Paint and other liquid construction material waste shall not be dumped into storm drains. Paint and other liquid construction waste washouts should be located at least 50 feet away from storm drain inlets unless there is no alternative. Other options are to install lined washouts or use portable, removable bags or bins. Hazardous or toxic waste shall be managed in accordance with the federal Resource Conservation and Recovery Act (RCRA) and NC Hazardous Waste Rules at 15A NCAC, Subchapter 13A. Litter and sanitary waste shall be managed in a manner to prevent it from entering jurisdictional waters and shall be disposed of offsite.

### **Herbicide, Pesticide, and Rodenticides**

Herbicide, pesticide, and rodenticides shall be stored and applied in accordance with the Federal Insecticide, Fungicide, and Rodenticide Act, North Carolina Pesticide Law of 1971 and labeling restrictions.

### **Concrete Materials**

Concrete materials onsite, including excess concrete, must be controlled and managed to avoid contact with surface waters, wetlands or buffers. No concrete or cement slurry shall be discharged from the site. (Note that discharges from onsite concrete plants require coverage under a separate NPDES permit – NCG140000.) Concrete wash water shall be managed in accordance with the *Concrete Washout Structure* provision. Concrete slurry shall be managed and disposed of in accordance with *NCDOT DGS and HOS DCAR Distribution of Class A Residuals Statewide* (Permit No. WQ0035749). Any hardened concrete residue will be disposed of, or recycled on site, in accordance with state solid waste regulations.

### **Earthen Material Stock Piles**

Earthen material stock piles shall be located at least 50 feet away from storm drain inlets and surface waters unless it can be shown that no other alternatives are reasonably available.

### **Measurement and Payment**

Conditions set within the *Construction Materials Management* provision are incidental to the project for which no direct compensation will be made.

**WASTE AND BORROW SOURCES:**

(2-16-11) (Rev. 3-17-22)

Payment for temporary erosion control measures, except those made necessary by the Contractor's own negligence or for his own convenience, will be paid for at the appropriate contract unit price for the devices or measures utilized in borrow sources and waste areas.

No additional payment will be made for erosion control devices or permanent seeding and mulching in any commercial borrow or waste pit. All erosion and sediment control practices that may be required on a commercial borrow or waste site will be done at the Contractor's expense.

All offsite Staging Areas, Borrow and Waste sites shall be in accordance with "Borrow and Waste Site Reclamation Procedures for Contracted Projects" located at:

<https://connect.ncdot.gov/resources/roadside/FieldOperationsDocuments/Contract%20Reclamation%20Procedures.pdf>

All forms and documents referenced in the "Borrow and Waste Site Reclamation Procedures for Contracted Projects" shall be included with the reclamation plans for offsite staging areas, and borrow and waste sites.

**TEMPORARY DIVERSION:**

This work consists of installation, maintenance, and cleanout of *Temporary Diversions* in accordance with Section 1630 of the *Standard Specifications*. The quantity of excavation for installation and cleanout will be measured and paid for as *Silt Excavation* in accordance with Article 1630-3 of the *Standard Specifications*.

**SAFETY FENCE AND JURISDICTIONAL FLAGGING:****Description**

*Safety Fence* shall consist of furnishing materials, installing and maintaining polyethylene or polypropylene fence along the outside riparian buffer, wetland, or water boundary, or other boundaries located within the construction corridor to mark the areas that have been approved to infringe within the buffer, wetland, endangered vegetation, culturally sensitive areas or water. The fence shall be installed prior to any land disturbing activities.

Interior boundaries for jurisdictional areas noted above shall be delineated by stakes and highly visible flagging.

Jurisdictional boundaries at staging areas, waste sites, or borrow pits, whether considered outside or interior boundaries shall be delineated by stakes and highly visible flagging.



**Materials****(A) Safety Fencing**

Polyethylene or polypropylene fence shall be a highly visible preconstructed safety fence approved by the Engineer. The fence material shall have an ultraviolet coating.

Either wood posts or steel posts may be used. Wood posts shall be hardwood with a wedge or pencil tip at one end, and shall be at least 5 ft. in length with a minimum nominal 2" x 2" cross section. Steel posts shall be at least 5 ft. in length, and have a minimum weight of 0.85 lb/ft of length.

**(B) Boundary Flagging**

Wooden stakes shall be 4 feet in length with a minimum nominal 3/4" x 1-3/4" cross section. The flagging shall be at least 1" in width. The flagging material shall be vinyl and shall be orange in color and highly visible.

**Construction Methods**

No additional clearing and grubbing is anticipated for the installation of this fence. The fence shall be erected to conform to the general contour of the ground.

**(A) Safety Fencing**

Posts shall be set at a maximum spacing of 10 ft., maintained in a vertical position and hand set or set with a post driver. Posts shall be installed a minimum of 2 ft. into the ground. If hand set, all backfill material shall be thoroughly tamped. Wood posts may be sharpened to a dull point if power driven. Posts damaged by power driving shall be removed and replaced prior to final acceptance. The tops of all wood posts shall be cut at a 30-degree angle. The wood posts may, at the option of the Contractor, be cut at this angle either before or after the posts are erected.

The fence geotextile shall be attached to the wood posts with one 2" galvanized wire staple across each cable or to the steel posts with wire or other acceptable means.

Place construction stakes to establish the location of the safety fence in accordance with Article 105-9 or Article 801-1 of the *Standard Specifications*. No direct pay will be made for the staking of the safety fence. All stakeouts for safety fence shall be considered incidental to the work being paid for as "Construction Surveying", except that where there is no pay item for construction surveying, all safety fence stakeout will be performed by state forces.

The Contractor shall be required to maintain the safety fence in a satisfactory condition for the duration of the project as determined by the Engineer.

**(B) Boundary Flagging**

Boundary flagging delineation of interior boundaries shall consist of wooden stakes on 25 feet maximum intervals with highly visible orange flagging attached. Stakes shall be installed a minimum of 6” into the ground. Interior boundaries may be staked on a tangent that runs parallel to buffer but must not encroach on the buffer at any location. Interior boundaries of hand clearing shall be identified with a different colored flagging to distinguish it from mechanized clearing.

Boundary flagging delineation of interior boundaries will be placed in accordance with Article 105-9 or Article 801-1 of the *Standard Specifications*. No direct pay will be made for delineation of the interior boundaries. This delineation will be considered incidental to the work being paid for as *Construction Surveying*, except that where there is no pay item or construction surveying the cost of boundary flagging delineation shall be included in the unit prices bid for the various items in the contract. Installation for delineation of all jurisdictional boundaries at staging areas, waste sites, or borrow pits shall consist of wooden stakes on 25 feet maximum intervals with highly visible orange flagging attached. Stakes shall be installed a minimum of 6” into the ground. Additional flagging may be placed on overhanging vegetation to enhance visibility but does not substitute for installation of stakes.

Installation of boundary flagging for delineation of all jurisdictional boundaries at staging areas, waste sites, or borrow pits shall be performed in accordance with Subarticle 230-4(B)(5) or Subarticle 802-2(F) of the *Standard Specifications*. No direct pay will be made for this delineation, as the cost of same shall be included in the unit prices bid for the various items in the contract.

The Contractor shall be required to maintain alternative stakes and highly visible flagging in a satisfactory condition for the duration of the project as determined by the Engineer.

**Measurement and Payment**

*Safety Fence* will be measured and paid as the actual number of linear feet of polyethylene or polypropylene fence installed in place and accepted. Such payment will be full compensation including but not limited to furnishing and installing fence geotextile with necessary posts and post bracing, staples, tie wires, tools, equipment and incidentals necessary to complete this work.

Payment will be made under:

**Pay Item**  
Safety Fence

**Pay Unit**  
Linear Foot

**IMPERVIOUS DIKE:**  
(9-9-11)(Rev. 11-15-22)

**Description**

This work consists of furnishing, installing, maintaining, pumping and removing an *Impervious Dike* for the purpose of diverting normal stream flow around the construction site. The Contractor

shall construct an impervious dike in such a manner approved by the Engineer. The impervious dike shall not permit seepage of water into the construction site or contribute to siltation of the stream. The impervious dike shall be constructed of an acceptable material in the locations noted on the plans or as directed by the Engineer.

### **Materials**

Acceptable materials shall include but not be limited to sheet piles, sandbags, and/or the placement of an acceptable size stone lined with polypropylene or other impervious geotextile.

Earth material shall not be used to construct an impervious dike when it is in direct contact with the stream unless vegetation can be established before contact with the stream takes place.

### **Construction Methods**

Where impervious dikes are shown on the plans and used to dewater or lower the water elevation, construct in accordance with Article 410-4 and 410-5.

### **Measurement and Payment**

*Impervious Dike* will be measured and paid as the actual number of linear feet of impervious dike(s) constructed, measured in place from end to end of each separate installation that has been completed and accepted by the Engineer. Such price and payment will be full compensation for all work including but not limited to furnishing materials, construction, maintenance, pumping and removal of the impervious dike.

Payment will be made under:

<b>Pay Item</b>	<b>Pay Unit</b>
Impervious Dike	Linear Foot

### **PUMP AROUND OPERATION:**

#### **Description**

The work covered by this section consists of furnishing, installing, maintaining and removing any and all pump around systems used on this project. The Contractor shall install a pump around system in locations as shown in the plans and in other locations approved by the Engineer. The pump around system shall provide a passageway for the stream flow around the work site. See the Example of Pump Around Operation Detail Sheet in the Erosion Control plans.

The quantity of pump around systems may be increased, decreased, or eliminated entirely as directed. Such variations in quantity will not be considered as alterations in the details of construction or a change in the character of the work.

**Materials**

<b>Item</b>	<b>Section</b>
Special Stilling Basin	1639

*Impervious Dike* shall meet the specifications as provided elsewhere in this contract.

Pumps shall be of sufficient size to divert the stream flow around the work area, as approved by the Engineer.

**Construction Methods**

Install *impervious dike(s)* as shown on the plans or as directed. Pump water around the work site. If the water is turbid or exposed to bare soil, pump through a *special stilling basin*. Once the work is complete in an area remove the *impervious dike(s)* and pump system, and stabilize the area.

**Measurement and Payment**

*Impervious Dike* will be measured and paid for as provided elsewhere in this contract.

*Special Stilling Basin* will be measured and paid for in accordance with Article 1639-4 of the *Standard Specifications*.

Payment for pumping operations shall be considered incidental to the work of installing pipes, culverts and channels. The pumping operations shall include but not be limited to, diverting the stream flow around the work area and pumping runoff from the work area into a stilling basin, special stilling basin or other sediment control device. No additional payment will be made for furnishing materials or maintenance of the pumping operations for the installation of pipes, culverts and channels.

The above prices and payments will be full compensation for all work covered by this section including, but not limited to furnishing all of the necessary materials, construction, maintenance and removal of the impervious dike and pump around system.

**FLOATING TURBIDITY CURTAIN:****Description**

This work consists of furnishing a *Floating Turbidity Curtain* to deter silt suspension and movement of silt particles during construction. The floating turbidity curtain shall be constructed at locations as directed.

**Materials**

The curtain material shall be made of a tightly woven nylon, plastic or other non-deteriorating material meeting the following specifications:

<b>Property</b>	<b>Value</b>
Grab tensile strength	*md-370 lbs *cd-250 lbs
Mullen burst strength	480 psi
Trapezoid tear strength	*md-100 lbs *cd-60 lbs
Apparent opening size	70 US standard sieve
Percent open area	4% permittivity 0.28 sec-1

\*md - machine direction

\*cd - cross machine direction

In the event that more than one width of fabric is required, a 6" overlap of the material shall also be required.

The curtain material shall be supported by a flotation material having over 29 lbs/ft buoyancy. The floating curtain shall have a 5/16" galvanized chain as ballast and dual 5/16" galvanized wire ropes with a heavy vinyl coating as load lines.

**Construction Methods**

The Contractor shall maintain the *Floating Turbidity Curtain* in a satisfactory condition until its removal is requested by the Engineer. The curtain shall extend to the bottom of the jurisdictional resource. Anchor the curtain according to manufacturer recommendations.

**Measurement and Payment**

*Floating Turbidity Curtain* will be measured and paid for as the actual number of square yards of curtain furnished as specified and accepted. Such price and payment will be full compensation for the work as described in this section including but not limited to furnishing all materials, tools, equipment, and all incidentals necessary to complete the work.

Payment will be made under:

<b>Pay Item</b>	<b>Pay Unit</b>
Floating Turbidity Curtain	Square Yard

**CONCRETE WASHOUT STRUCTURE:**

(8-17-23)

**Description**

Concrete washout structures are enclosures above or below grade to contain concrete waste water and associated concrete mix from washing out ready-mix trucks, drums, pumps, or other equipment. Concrete washouts must collect and retain all the concrete washout water and solids, so that this material does not migrate to surface waters or into the ground water. These enclosures are not intended for concrete waste not associated with wash out operations.

The concrete washout structure may include constructed devices above or below ground and or commercially available devices designed specifically to capture concrete wash water.

### **Materials**

<b>Item</b>	<b>Section</b>
Temporary Silt Fence	1605

*Safety Fence* shall meet the specifications as provided elsewhere in this contract.

Geomembrane basin liner shall meet the following minimum physical properties for low permeability; it shall consist of a polypropylene or polyethylene 10 mil thick geomembrane. If the minimum setback dimensions can be achieved the liner is not required. (5 feet above groundwater, 50 feet from top of bank of perennial stream, other surface water body, or wetland.)

### **Construction Methods**

Build an enclosed earthen berm or excavate to form an enclosure in accordance with the details and as directed.

Install temporary silt fence around the perimeter of the enclosure in accordance with the details and as directed if structure is not located in an area where existing erosion and sedimentation control devices are capable to containing any loss of sediment.

Post a sign with the words “Concrete Washout” in close proximity of the concrete washout area, so it is clearly visible to site personnel. Install safety fence as directed for visibility to construction traffic.

Alternate details for accommodating concrete washout may be submitted for review and approval.

The alternate details shall include the method used to retain and dispose of concrete waste water within the project limits and in accordance with the minimum setback requirements. (5 feet above groundwater, 50 feet from top of bank of perennial stream, other surface water body, or wetland.)

### **Maintenance and Removal**

Maintain the concrete washout structure(s) to provide adequate holding capacity plus a minimum freeboard of 12 inches. Remove and dispose of hardened concrete and return the structure to a functional condition after reaching 75% capacity.

Inspect concrete washout structures for damage and maintain for effectiveness.

Remove the concrete washout structures and sign upon project completion. Grade the earth material to match the existing contours and permanently seed and mulch area.

**Measurement and Payment**

*Concrete Washout Structure* will be paid for per each enclosure installed in accordance with the details. If alternate details or commercially available devices are approved, then those devices will also be paid for per each approved and installed device.

*Temporary Silt Fence* will be measured and paid for in accordance with Article 1605-5 of the *Standard Specifications*.

*Safety Fence* shall be measured and paid for as provided elsewhere in this contract.

No measurement will be made for other items or for over excavation or stockpiling.

Payment will be made under:

<b>Pay Item</b>	<b>Pay Unit</b>
Concrete Washout Structure	Each

**FABRIC INSERT INLET PROTECTION**

(1-1-24)

**Description**

Install, maintain, and remove Fabric Insert Inlet Protection, of the type specified, in inlet structures (catch basins, drop inlets, etc.) in areas where asphalt or concrete may prevent the proper installation of a Rock Inlet Sediment Traps Type C, or as directed by the Engineer.

**Materials**

Provide a fabric inlet protection device composed of a fitted woven polypropylene geotextile double sewn with nylon thread suspended sack. The Fabric Insert Inlet Protection shall be manufactured to fit the opening of the catch basin or drop inlet or shall have a deflector to direct runoff from the curb opening into the fabric sack. The Fabric Insert Inlet Protection shall have a rigid frame or support system to support the loaded weight of the product. The product shall have lifting loops for removing the device from the basin and will have dump straps attached at the bottom to facilitate the emptying of the device. The Fabric Insert Inlet Protection shall have an overflow system to allow stormwater to enter the inlet structure and avoid ponding on the roadway when the device reaches capacity.

The fitted filter assembly shall have the following physical properties:

Type 1 (High Flow):

<b>Physical</b>	<b>Test Method</b>	<b>English</b>
Grab Tensile	ASTM D-4632	255 x 275 lbs
Minimum Puncture Strength	ASTM D-4833	125 lbs
Mullen Burst	ASTM D-3786	420 PSI
Minimum UV Resistance	ASTM D-4355	70 %.
Flow Rate	ASTM D-4491	200 gal/min/ft <sup>2</sup>
Apparent Opening	ASTM D-4751	20 US Sieve
Permittivity	ASTM D-4491	1.5 sec <sup>-1</sup>

Type 2 (Low Flow):

<b>Physical</b>	<b>Test Method</b>	<b>English</b>
Grab Tensile	ASTM D-4632	315 x 300 lbs
Grab Elongation	ASTM D-4632	15 x 15 %
Minimum Puncture Strength	ASTM D-4833	125 lbs
Mullen Burst	ASTM D-3786	650 PSI
Minimum UV Resistance	ASTM D-4355	70 %.
Flow Rate	ASTM D-4491	40 gal/min/ft <sup>2</sup>
Apparent Opening	ASTM D-4751	40 US Sieve
Permittivity	ASTM D-4491	0.55 sec <sup>-1</sup>

**Construction Methods**

Strictly adhere to the manufacturer’s installation instructions and recommendations. Maintenance shall include regular daily inspections and after each qualifying rain event. The Fabric Insert Inlet Protection shall be emptied, cleaned and placed back into the basin when it reaches 50% capacity or as directed by the Engineer.

**Measurement and Payment**

*Fabric Insert Inlet Protection, Type \_\_* will be measured and paid in units of each of the type specified, complete in place and accepted. Such payment shall be full compensation for furnishing and installing the *Fabric Insert Inlet Protection, Type \_\_* in accordance with this specification and for all required maintenance.

*Fabric Insert Inlet Protection Cleanout* will be measured and paid in units of each for the maintenance of the device, cleanout and disposal of accumulated sediments.

Payment will be made under:

<b>Pay Item</b>	<b>Pay Unit</b>
Fabric Insert Inlet Protection, Type __	Each
Fabric Insert Inlet Protection Cleanout	Each



U-3422A

TS-1

Cumberland County

Signals and Intelligent Transportation Systems  
Project Special Provisions  
(Version 24.1)

Prepared By: LMM  
9-Sep-24

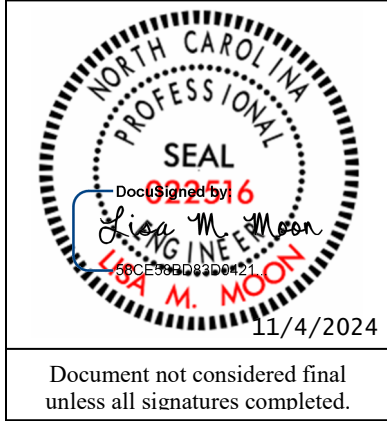

Contents

**1. 2024 STANDARD SPECIFICATIONS FOR ROADS & STRUCTURES.....3**

1.1. ELECTRICAL JUNCTION BOXES (1091-5).....3

**2. SIGNAL HEADS.....3**

2.1. MATERIALS .....3

A. General: .....3

B. Vehicle Signal Heads:.....5

C. Pedestrian Signal Heads: .....8

**3. CONTROLLERS WITH CABINETS .....10**

3.1. MATERIALS – TYPE 2070LX CONTROLLERS ..... 10

3.2. MATERIALS – GENERAL CABINETS ..... 10

3.3. MATERIALS – TYPE 170E CABINETS ..... 11

A. Type 170 E Cabinets General: ..... 11

B. Type 170 E Cabinet Electrical Requirements: ..... 11

C. Type 170 E Cabinet Physical Requirements: ..... 18

D. Model 2018 Enhanced Conflict Monitor: ..... 21

3.4. MATERIALS – TYPE 170 DETECTOR SENSOR UNITS ..... 31

3.5. MEASUREMENT AND PAYMENT ..... 31

**4. MICROWAVE VEHICLE DETECTION SYSTEM - MULTIPLE DETECTION ZONES.....32**

4.1. DESCRIPTION ..... 32

4.2. MATERIALS ..... 32

4.3. CONSTRUCTION METHODS ..... 33

4.4. MEASUREMENT AND PAYMENT ..... 33

**5. METAL POLE SUPPORTS .....33**

5.1. METAL POLES ..... 33

A. General: ..... 33

B. Materials: ..... 35

C. Design: ..... 37

D. Strain Poles: ..... 39

5.2. DRILLED PIER FOUNDATIONS FOR METAL POLES..... 39

A. Description: ..... 40

B. Soil Test and Foundation Determination: ..... 40

C. Drilled Pier Construction: ..... 42

5.3. POLE NUMBERING SYSTEM ..... 43

A. New Poles ..... 43

5.4. MEASUREMENT AND PAYMENT ..... 43

**6. ETHERNET EDGE SWITCH.....43**

6.1. DESCRIPTION ..... 43

6.2. MATERIALS ..... 43

**U-3422A**

**TS-2**

***Cumberland County***

6.3.	CONSTRUCTION METHODS .....	48
6.4.	MEASUREMENT AND PAYMENT .....	48

U-3422A

TS-3

Cumberland County

## 1. 2024 STANDARD SPECIFICATIONS FOR ROADS & STRUCTURES

*The 2024 Standard Specifications are revised as follows:*

### 1.1. ELECTRICAL JUNCTION BOXES (1091-5)

Page 10-209, revise paragraphs beginning on line 26 to read "Provide electrical junction boxes with covers of the type and size indicated by the contract or plans for the termination of conduits. Boxes and covers shall meet all requirements and specifications of ANSI/SCTE 77 2017. Structural load tests shall meet the Tier 15 application type."

Page 10-209, line 28, revise title of section 1091-5(B) from "Polymer Concrete (PC) Junction Boxes" to "Polymer Concrete (PC), Composite, and Thermoplastic Junction Boxes".

Page 10-209, revise paragraphs beginning on line 29 through line 41 to read "For PC junction boxes, use polymer concrete material made of an aggregate consisting of sand and gravel bound together with a polymer and reinforced with glass strands to fabricate box and cover components. Provide junction boxes which have bolted covers and open bottoms. Provide vertical extensions of 6 inches to 12 inches as required by project provisions.

Provide the required logo on the cover. Provide at least two size 3/8 inch diameter hex head stainless steel cover bolts to match inserts in the box. Provide pull slot(s) with stainless steel pin(s). Bodies of junction boxes shall be a single piece.

Polymer concrete, composite, and thermoplastic junction boxes are not required to be listed electrical devices."

## 2. SIGNAL HEADS

### 2.1. MATERIALS

#### A. General:

Fabricate vehicle signal head housings and end caps from die-cast aluminum. Fabricate 12-inch and 16-inch pedestrian signal head housings and end caps from die-cast aluminum. Fabricate 9-inch pedestrian signal head housings, end caps, and visors from virgin polycarbonate material. Provide visor mounting screws, door latches, and hinge pins fabricated from stainless steel. Provide interior screws, fasteners, and metal parts fabricated from stainless steel.

Fabricate tunnel and traditional visors from sheet aluminum.

Paint all surfaces inside and outside of signal housings and doors. Paint outside surfaces of tunnel and traditional visors, wire outlet bodies, wire entrance fitting brackets and end caps when supplied as components of messenger cable mounting assemblies, pole and pedestal mounting assemblies, and pedestrian pushbutton housings. Have electrostatically-applied, fused-polyester paint in highway yellow (Federal Standard 595C, Color Chip Number 13538) a minimum of 2.5 to 3.5 mils thick. Do not apply paint to the latching hardware, rigid vehicle signal head mounting brackets for mast-arm attachments, messenger cable hanger components or balance adjuster components.

Have the interior surfaces of tunnel and traditional visors painted an alkyd urea black synthetic baking enamel with a minimum gloss reflectance and meeting the requirements of MIL-E-10169, "Enamel Heat Resisting, Instrument Black."

Where required, provide polycarbonate signal heads and visors that comply with the provisions pertaining to the aluminum signal heads listed on the QPL with the following exceptions:

Fabricate signal head housings, end caps, and visors from virgin polycarbonate material. Provide UV stabilized polycarbonate plastic with a minimum thickness of 0.1 ± 0.01 inches that is highway yellow (Federal Standard 595C, Color Chip 13538). Ensure the color is incorporated into the plastic material before molding the signal head housings and end caps. Ensure the plastic formulation provides the following physical properties in the assembly (tests may be performed on separately molded specimens):

Test	Required	Method
Specific Gravity	1.17 minimum	ASTM D 792
Flammability	Self-extinguishing	ASTM D 635
Tensile Strength, yield, PSI	8500 minimum	ASTM D 638
Izod impact strength, ft-lb/in [notched, 1/8 inch]	12 minimum	ASTM D 256

For pole mounting, provide side of pole mounting assemblies with framework and all other hardware necessary to make complete, watertight connections of the signal heads to the poles and pedestals. Fabricate the mounting assemblies and frames from aluminum with all necessary hardware, screws, washers, etc. to be stainless steel. Provide mounting fittings that match the positive locking device on the signal head with the serrations integrally cast into the brackets. Provide upper and lower pole plates that have a 1 ¼-inch vertical conduit entrance hubs with the hubs capped on the lower plate and 1 ½-inch horizontal hubs. Ensure that the assemblies provide rigid attachments to poles and pedestals so as to allow no twisting or swaying of the signal heads. Ensure that all raceways are free of sharp edges and protrusions, and can accommodate a minimum of ten Number 14 AWG conductors.

For pedestal mounting, provide a post-top slipfitter mounting assembly that matches the positive locking device on the signal head with serrations integrally cast into the slipfitter. Provide stainless steel hardware, screws, washers, etc. Provide a minimum of six 3/8 X 3/4-inch long square head bolts for attachment to pedestal. Provide a center post for multi-way slipfitters.

For light emitting diode (LED) traffic signal modules, provide the following requirements for inclusion on the Department’s Qualified Products List for traffic signal equipment.

1. Sample submittal,
2. Third-party independent laboratory testing results for each submitted module with evidence of testing and conformance with all of the Design Qualification Testing specified in section 6.4 of each of the following Institute of Transportation Engineers (ITE) specifications:
  - Vehicle Traffic Control Signal Heads – Light Emitting Diode (LED) Circular Signal Supplement
  - Vehicle Traffic Control Signal Heads – Light Emitting Diode (LED) Vehicle Arrow Traffic Signal Supplement
  - Pedestrian Traffic Control Signal Indications –Light Emitting Diode (LED) Signal Modules.

(Note: The Department currently recognizes two approved independent testing laboratories. They are Intertek ETL Semko and Light Metrics, Incorporated with Garwood Laboratories.

Independent laboratory tests from other laboratories may be considered as part of the QPL submittal at the discretion of the Department,

3. Evidence of conformance with the requirements of these specifications,
4. A manufacturer's warranty statement in accordance with the required warranty, and
5. Submittal of manufacturer's design and production documentation for the model, including but not limited to, electrical schematics, electronic component values, proprietary part numbers, bill of materials, and production electrical and photometric test parameters.
6. Evidence of approval of the product to bear the Intertek ETL Verified product label for LED traffic signal modules.

Ensure LED traffic signal modules meet the performance requirements for the minimum period of 15 years, provide a written warranty against defects in materials and workmanship for the modules for a period of 15 years after installation of the modules. During the warranty period, the manufacturer must provide new replacement modules within 45 days of receipt of modules that have failed at no cost to the State. Repaired or refurbished modules may not be used to fulfill the manufacturer's warranty obligations. Provide manufacturer's warranty documentation to the Department during evaluation of product for inclusion on Qualified Products List (QPL).

#### **B. Vehicle Signal Heads:**

Comply with the ITE standard "Vehicle Traffic Control Signal Heads". Provide housings with provisions for attaching backplates.

Provide visors that are 8 inches in length for 8-inch vehicle signal head sections. Provide visors that are 10 inches in length for 12-inch vehicle signal heads.

Provide a termination block with one empty terminal for field wiring for each indication plus one empty terminal for the neutral conductor. Have all signal sections wired to the termination block. Provide barriers between the terminals that have terminal screws with a minimum Number 8 thread size and that will accommodate and secure spade lugs sized for a Number 10 terminal screw.

Mount termination blocks in the yellow signal head sections on all in-line vehicle signal heads. Mount the termination block in the red section on five-section vehicle signal heads.

Furnish vehicle signal head interconnecting brackets. Provide one-piece aluminum brackets less than 4.5 inches in height and with no threaded pipe connections. Provide hand holes on the bottom of the brackets to aid in installing wires to the signal heads. Lower brackets that carry no wires and are used only for connecting the bottom signal sections together may be flat in construction.

For messenger cable mounting, provide messenger cable hangers, wire outlet bodies, balance adjusters, bottom caps, wire entrance fitting brackets, and all other hardware necessary to make complete, watertight connections of the vehicle signal heads to the messenger cable. Fabricate messenger cable hanger components, wire outlet bodies and balance adjuster components from stainless steel or malleable iron galvanized in accordance with ASTM A153 (Class A) or ASTM A123. Provide serrated rings made of aluminum. Provide messenger cable hangers with U-bolt clamps. Fabricate washers, screws, hex-head bolts and associated nuts, clevis pins, cotter pins, U-bolt clamps and nuts from stainless steel.

For mast-arm mounting, provide rigid vehicle signal head mounting brackets and all other hardware necessary to make complete, watertight connections of the vehicle signal heads to the mast arms and to provide a means for vertically adjusting the vehicle signal heads to proper alignment. Fabricate the mounting assemblies from aluminum, and provide serrated rings made of aluminum.

Provide stainless steel cable attachment assemblies to secure the brackets to the mast arms. Ensure all fastening hardware and fasteners are fabricated from stainless steel.

Provide LED vehicular traffic signal modules (hereafter referred to as modules) that consist of an assembly that uses LEDs as the light source in lieu of an incandescent lamp for use in traffic signal sections. Use LEDs that are aluminum indium gallium phosphorus (AlInGaP) technology for red and yellow indications and indium gallium nitride (InGaN) for green indications. Install the ultra bright type LEDs that are rated for 100,000 hours of continuous operation from -40°F to +165°F. Design modules to have a minimum useful life of 15 years and to meet all parameters of this specification during this period of useful life.

For the modules, provide spade terminals crimped to the lead wires and sized for a #10 screw connection to the existing terminal block in a standard signal head. Do not provide other types of crimped terminals with a spade adapter.

Ensure the power supply is integral to the module assembly. On the back of the module, permanently mark the date of manufacture (month & year) or some other method of identifying date of manufacture.

Tint the red, yellow and green lenses to correspond with the wavelength (chromaticity) of the LED. Transparent tinting films are unacceptable. Provide a lens that is integral to the unit with a smooth outer surface.

**1. LED Circular Signal Modules:**

Provide modules in the following configurations: 12-inch circular sections, and 8-inch circular sections. All makes and models of LED modules purchased for use on the State Highway System shall appear on the current NCDOT Traffic Signal Qualified Products List (QPL).

Provide the manufacturer’s model number and the product number (assigned by the Department) for each module that appears on the 2024 or most recent Qualified Products List. In addition, provide manufacturer’s certification in accordance with Article 106-3 of the *Standard Specifications*, that each module meets or exceeds the ITE “Vehicle Traffic Control Signal Heads – Light Emitting Diode (LED) Circular Signal Supplement” dated June 27, 2005 (hereafter referred to as VTCSH Circular Supplement) and other requirements stated in this specification.

Provide modules that meet the following requirements when tested under the procedures outlined in the VTCSH Circular Supplement:

Module Type	Max. Wattage at 165° F	Nominal Wattage at 77° F
12-inch red circular	17	11
8-inch red circular	13	8
12-inch green circular	15	15
8-inch green circular	12	12

For yellow circular signal modules, provide modules tested under the procedures outlined in the VTCSH Circular Supplement to insure power required at 77° F is 22 Watts or less for the 12-inch circular module and 13 Watts or less for the 8-inch circular module.

Note: Use a wattmeter having an accuracy of ±1% to measure the nominal wattage and maximum wattage of a circular traffic signal module. Power may also be derived from voltage, current and power factor measurements.

**2. LED Arrow Signal Modules**

Provide 12-inch omnidirectional arrow signal modules. All makes and models of LED modules purchased for use on the State Highway System shall appear on the current NCDOT Traffic Signal Qualified Products List (QPL).

Provide the manufacturer’s model number and the product number (assigned by the Department) for each module that appears on the 2024 or most recent Qualified Products List. In addition, provide manufacturer’s certification in accordance with Article 106-3 of the *Standard Specifications*, that each module meets or exceeds the requirements for 12-inch omnidirectional modules specified in the ITE “Vehicle Traffic Control Signal Heads – Light Emitting Diode (LED) Vehicle Arrow Traffic Signal Supplement” dated July 1, 2007 (hereafter referred to as VTCSH Arrow Supplement) and other requirements stated in this specification.

Provide modules that meet the following requirements when tested under the procedures outlined in the VTCSH Arrow Supplement:

Module Type	Max. Wattage at 165° F	Nominal Wattage at 77° F
12-inch red arrow	12	9
12-inch green arrow	11	11

For yellow arrow signal modules, provide modules tested under the procedures outlined in the VTCSH Arrow Supplement to insure power required at 77° F is 12 Watts or less.

Note: Use a wattmeter having an accuracy of ±1% to measure the nominal wattage and maximum wattage of an arrow traffic signal module. Power may also be derived from voltage, current and power factor measurements.

**3. LED U-Turn Arrow Signal Modules:**

Provide modules in the following configurations: 12-inch left u-turn arrow signal modules and 12-inch right u-turn arrow signal modules.

Modules are not required to be listed on the ITS and Signals Qualified Products List. Provide manufacturer’s certification in accordance with Article 106-3 of the *Standard Specifications*, that each module meets or exceeds the ITE “Vehicle Traffic Control Signal Heads – Light Emitting Diode (LED) Circular Signal Supplement” dated June 27, 2005 (hereafter referred to as VTCSH Circular Supplement) and other requirements stated in this specification.

Provide modules that have minimum maintained luminous intensity values that are not less than 16% of the values calculated using the method described in section 4.1 of the VTCSH Circular Supplement.

Provide modules that meet the following requirements when tested under the procedures outlined in the VTCSH Circular Supplement:

Module Type	Max. Wattage at 165° F	Nominal Wattage at 77° F
12-inch red u-turn arrow	17	11
12-inch green u-turn arrow	15	15

For yellow u-turn arrow signal modules, provide modules tested under the procedures outlined in the VTCSH Circular Supplement to ensure power required at 77° F is 22 Watts or less.

Note: Use a wattmeter having an accuracy of ±1% to measure the nominal wattage and maximum wattage of a circular traffic signal module. Power may also be derived from voltage, current and power factor measurements.

**4. LED Bi-Modal Green-Yellow Arrow Signal Modules**

Provide 12-inch omnidirectional bi-modal arrow signal modules. Ensure both green and yellow arrow indications are in each module with a clear lens that is integral to the unit. Ensure both indications display an incandescent style look.

Modules are not required to be listed on the ITS and Signals Qualified Products List. Ensure that both indications along with the module meet or exceed the requirements in sections 1, 2, 3, 4 and 5 of the VTCSH Arrow Supplement and other requirements stated in this specification.

Provide modules that meet the following requirements when tested under the procedures outlined in the VTCSH Arrow Supplement:

Arrow Type	Nominal Wattage at 77° F
12-inch yellow arrow	12
12-inch green arrow	11

Note: Use a wattmeter having an accuracy of  $\pm 1\%$  to measure the nominal wattage and maximum wattage of a circular traffic signal module. Power may also be derived from voltage, current and power factor measurements.

**C. Pedestrian Signal Heads:**

Provide pedestrian signal heads with international symbols that meet the MUTCD. Do not provide letter indications.

Comply with the ITE standard for “Pedestrian Traffic Control Signal Indications” and the following sections of the ITE standard for “Vehicle Traffic Control Signal Heads” in effect on the date of advertisement:

- Section 3.00 - “Physical and Mechanical Requirements”
- Section 4.01 - “Housing, Door, and Visor: General”
- Section 4.04 - “Housing, Door, and Visor: Materials and Fabrication”
- Section 7.00 - “Exterior Finish”

Provide a double-row termination block with three empty terminals and number 10 screws for field wiring. Provide barriers between the terminals that accommodate a spade lug sized for number 10 terminal screws. Mount the termination block in the hand section. Wire all signal sections to the terminal block.

Where required by the plans, provide 16-inch pedestrian signal heads with traditional three-sided, rectangular visors, 6 inches long. Where required by the plans, provide 12-inch pedestrian signal heads with traditional three-sided, rectangular visors, 8 inches long.

Provide 2-inch diameter pedestrian push-buttons with weather-tight housings fabricated from die-cast aluminum and threading in compliance with the NEC for rigid metal conduit. Provide a weep hole in the housing bottom and ensure that the unit is vandal resistant.

Provide push-button housings that are suitable for mounting on flat or curved surfaces and that will accept 1/2-inch conduit installed in the top. Provide units that have a heavy duty push-button assembly with a sturdy, momentary, normally-open switch. Have contacts that are electrically insulated from the housing and push-button. Ensure that the push-buttons are rated for a minimum of 5 mA at 24 volts DC and 250 mA at 12 volts AC.



Provide standard R10-3 signs with mounting hardware that comply with the MUTCD in effect on the date of advertisement. Provide R10-3E signs for countdown pedestrian heads and R10-3B for non-countdown pedestrian heads.

Design the LED pedestrian traffic signal modules (hereafter referred to as modules) for installation into standard pedestrian traffic signal sections that do not contain the incandescent signal section reflector, lens, eggcrate visor, gasket, or socket. Provide modules that consist of an assembly that uses LEDs as the light source in lieu of an incandescent lamp. Use LEDs that are of the latest aluminum indium gallium phosphorus (AlInGaP) technology for the Portland Orange hand and countdown displays. Use LEDs that are of the latest indium gallium nitride (InGaN) technology for the Lunar White walking man displays. Install the ultra-bright type LEDs that are rated for 100,000 hours of continuous operation from -40°F to +165°F. Design modules to have a minimum useful life of 60 months and to meet all parameters of this specification during this period of useful life.

Design all modules to operate using a standard 3 - wire field installation. Provide spade terminals crimped to the lead wires and sized for a #10 screw connection to the existing terminal block in a standard pedestrian signal housing. Do not provide other types of crimped terminals with a spade adapter.

Ensure the power supply is integral to the module assembly. On the back of the module, permanently mark the date of manufacture (month & year) or some other method of identifying date of manufacture.

Provide modules in the following configuration: 16-inch displays which have the solid hand/walking man overlay on the left and the countdown on the right, and 12-inch displays which have the solid hand/walking man module as an overlay. All makes and models of LED modules purchased for use on the State Highway System shall appear on the current NCDOT Traffic Signal Qualified Products List (QPL).

Provide the manufacturer’s model number and the product number (assigned by the Department) for each module that appears on the 2024 or most recent Qualified Products List. In addition, provide manufacturer’s certification in accordance with Article 106-3 of the *Standard Specifications*, that each module meets or exceeds the ITE “Pedestrian Traffic Control Signal Indicators - Light Emitting Diode (LED) Signal Modules” dated August 04, 2010 (hereafter referred to as PTCSI Pedestrian Standard) and other requirements stated in this specification.

Provide modules that meet the following requirements when tested under the procedures outlined in the PTCSI Pedestrian Standard:

Module Type	Max. Wattage at 165° F	Nominal Wattage at 77° F
Hand Indication	16	13
Walking Man Indication	12	9
Countdown Indication	16	13

Note: Use a wattmeter having an accuracy of ±1% to measure the nominal wattage and maximum wattage of a circular traffic signal module. Power may also be derived from voltage, current and power factor measurements.

Provide module lens that is hard coated or otherwise made to comply with the material exposure and weathering effects requirements of the Society of Automotive Engineers (SAE) J576. Ensure all exposed components of the module are suitable for prolonged exposure to the environment, without appreciable degradation that would interfere with function or appearance.

Ensure the countdown display continuously monitors the traffic controller to automatically learn the pedestrian phase time and update for subsequent changes to the pedestrian phase time.

Ensure the countdown display begins normal operation upon the completion of the preemption sequence and no more than one pedestrian clearance cycle.

**3. CONTROLLERS WITH CABINETS**

**3.1. MATERIALS – TYPE 2070LX CONTROLLERS**

Furnish model 2070LX controller units that conform to CALTRANS *Transportation Electrical Equipment Specifications* (TEES) (dated March 12, 2009, plus Errata 1 dated January 21, 2010 and Errata 2 dated December 5, 2014) except as required herein.

The Department will provide software at the beginning of the burning-in period. Contractor shall give 5 working days notice before needing software. Program software provided by the Department.

Provide model 2070LX controllers with Linux kernel 2.6.18 or higher and device drivers, composed of the unit chassis and at a minimum the following modules and assemblies:

- MODEL 2070-1C, CPU Module, Single Board, with 8Mb Datakey (blue in color)
- MODEL 2070-2E+, Field I/O Module (FI/O)
  - Note: Configure the Field I/O Module to disable both the External WDT Shunt/Toggle Switch and SP3 (SP3 active indicator is “off”)
- MODEL 2070-3B, Front Panel Module (FP), Display B (8x40)
- MODEL 2070-4A, Power Supply Module, 10 AMP

Provide a Board Support Package (BSP) to the state and to any specified applications software manufacturer when requested by the state to facilitate the porting of application software.

**3.2.MATERIALS – GENERAL CABINETS**

Provide a moisture resistant coating on all circuit boards.

Provide one 20 mm diameter radial lead UL-recognized metal oxide varistor (MOV) between each load switch field terminal and equipment ground. Electrical performance is outlined below.

<b>PROPERTIES OF MOV SURGE PROTECTOR</b>	
Maximum Continuous Applied Voltage at 185° F	150 VAC (RMS) 200 VDC
Maximum Peak 8x20µs Current at 185° F	6500 A
Maximum Energy Rating at 185° F	80 J
Voltage Range 1 mA DC Test at 77° F	212-268 V
Max. Clamping Voltage 8x20µs, 100A at 77° F	395 V
Typical Capacitance (1 MHz) at 77° F	1600 pF

Provide a power line surge protector that is a two-stage device that will allow connection of the radio frequency interference filter between the stages of the device. Ensure that a maximum continuous current is at least 10A at 120V. Ensure that the device can withstand a minimum of 20 peak surge current occurrences at 20,000A for an 8x20 microsecond waveform. Provide a maximum

clamp voltage of 395V at 20,000A with a nominal series inductance of 200μh. Ensure that the voltage does not exceed 395V. Provide devices that comply with the following:

Frequency (Hz)	Minimum Insertion Loss (dB)
60	0
10,000	30
50,000	55
100,000	50
500,000	50
2,000,000	60
5,000,000	40
10,000,000	20
20,000,000	25

**3.3. MATERIALS – TYPE 170E CABINETS**

**A. Type 170 E Cabinets General:**

Conform to the city of Los Angeles’ Specification No. 54-053-08, *Traffic Signal Cabinet Assembly Specification* (dated July 2008), except as required herein.

Furnish model 336S pole mounted cabinets configured for 8 vehicle phases, 4 pedestrian phases, and 6 overlaps. Do not reassign load switches to accommodate overlaps unless shown on electrical details. Provide 336S pole mounted cabinets that are 46” high with 40” high internal rack assemblies.

Furnish model 332 base mounted cabinets configured for 8 vehicle phases, 4 pedestrian phases, and 6 overlaps. When overlaps are required, provide auxiliary output files for the overlaps. Do not reassign load switches to accommodate overlaps unless shown on electrical details.

Provide model 200 load switches, model 222 loop detector sensors, model 252 AC isolators, and model 242 DC isolators according to the electrical details. As a minimum, provide one (1) model 2018 conflict monitor, one (1) model 206L power supply unit, two (2) model 204 flashers, one (1) DC isolator (located in slot I14), and four (4) model 430 flash transfer relays (provide seven (7) model 430 flash transfer relays if auxiliary output file is installed) with each cabinet.

**B. Type 170 E Cabinet Electrical Requirements:**

Provide a cabinet assembly designed to ensure that upon leaving any cabinet switch or conflict monitor initiated flashing operation, the controller starts up in the programmed start up phases and start up interval.

Furnish two sets of non-fading cabinet wiring diagrams and schematics in a paper envelope or container and placed in the cabinet drawer.

All AC+ power is subject to radio frequency signal suppression.

Provide surge suppression in the cabinet for each type of cabinet device. Provide surge protection for the full capacity of the cabinet input file. Provide surge suppression devices that operate properly over a temperature range of -40° F to +185° F. Ensure the surge suppression devices provide both common and differential modes of protection.

Provide a pluggable power line surge protector that is installed on the back of the PDA (power distribution assembly) chassis to filter and absorb power line noise and switching transients. Ensure the device incorporates LEDs for failure indication and provides a dry relay contact closure for the purpose of remote sensing. Ensure the device meets the following specifications:

- Peak Surge Current (Single pulse, 8x20µs).....20,000A
- Occurrences (8x20µs waveform).....10 minimum @ 20,000A
- Maximum Clamp Voltage.....395VAC
- Operating Current.....15 amps
- Response Time.....< 5 nanoseconds

Provide a loop surge suppressor for each set of loop terminals in the cabinet. Ensure the device meets the following specifications:

- Peak Surge Current (6 times, 8x20µs)
  - (Differential Mode).....400A
  - (Common Mode).....1,000A
- Occurrences (8x20µs waveform).....500 min @ 200A
- Maximum Clamp Voltage
  - (Differential Mode @400A).....35V
  - (Common Mode @1,000A).....35V
- Response Time.....< 5 nanoseconds
- Maximum Capacitance.....35 pF

Provide a data communications surge suppressor for each communications line entering or leaving the cabinet. Ensure the device meets the following specifications:

- Peak Surge Current (Single pulse, 8x20µs).....10,000A
- Occurrences (8x20µs waveform).....100 min @ 2,000A
- Maximum Clamp Voltage.....Rated for equipment protected
- Response Time.....< 1 nanosecond
- Maximum Capacitance.....1,500 pF
- Maximum Series Resistance.....15Ω

Provide a DC signal surge suppressor for each DC input channel in the cabinet. Ensure the device meets the following specifications:

- Peak Surge Current (Single pulse, 8x20µs).....10,000A
- Occurrences (8x20µs waveform).....100 @ 2,000A
- Maximum Clamp Voltage.....30V

Response Time.....< 1 nanosecond

Provide a 120 VAC signal surge suppressor for each AC+ interconnect signal input. Ensure the device meets the following specifications:

- Peak Surge Current (Single pulse, 8x20µs).....20,000A
- Maximum Clamp Voltage.....350VAC
- Response Time.....< 200 nanoseconds
- Discharge Voltage.....<200 Volts @ 1,000A
- Insulation Resistance.....≥100 MΩ

Provide conductors for surge protection wiring that are of sufficient size (ampacity) to withstand maximum overcurrents which could occur before protective device thresholds are attained and current flow is interrupted.

If additional surge protected power outlets are needed to accommodate fiber transceivers, modems, etc., install a UL listed, industrial, heavy-duty type power outlet strip with a minimum rating of 15 A / 125 VAC, 60 Hz. Provide a strip that has a minimum of 3 grounded outlets. Ensure the power outlet strip plugs into one of the controller unit receptacles located on the rear of the PDA. Ensure power outlet strip is mounted securely; provide strain relief if necessary.

Provide a door switch in the front and a door switch in the rear of the cabinet that will provide the controller unit with a Door Ajar alarm when either the front or the rear door is open. Ensure the door switches apply DC ground to the Input File when either the front door or the rear door is open.

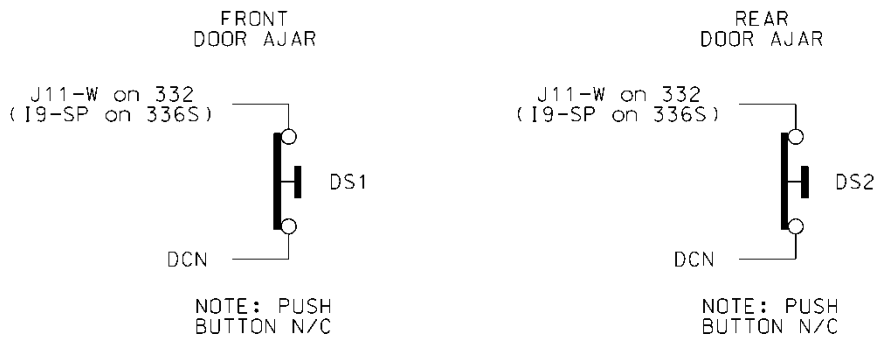

Furnish a fluorescent fixture in the rear across the top of the cabinet and another fluorescent fixture in the front across the top of the cabinet at a minimum. Ensure that the fixtures provide sufficient light to illuminate all terminals, labels, switches, and devices in the cabinet. Conveniently locate the fixtures so as not to interfere with a technician’s ability to perform work on any devices or terminals in the cabinet. Provide a protective diffuser to cover exposed bulbs. Install 16 watt T-4 lamps in the fluorescent fixtures. Provide a door switch to provide power to each fixture when the respective door is open. Wire the fluorescent fixtures to the 15 amp ECB (equipment circuit breaker).

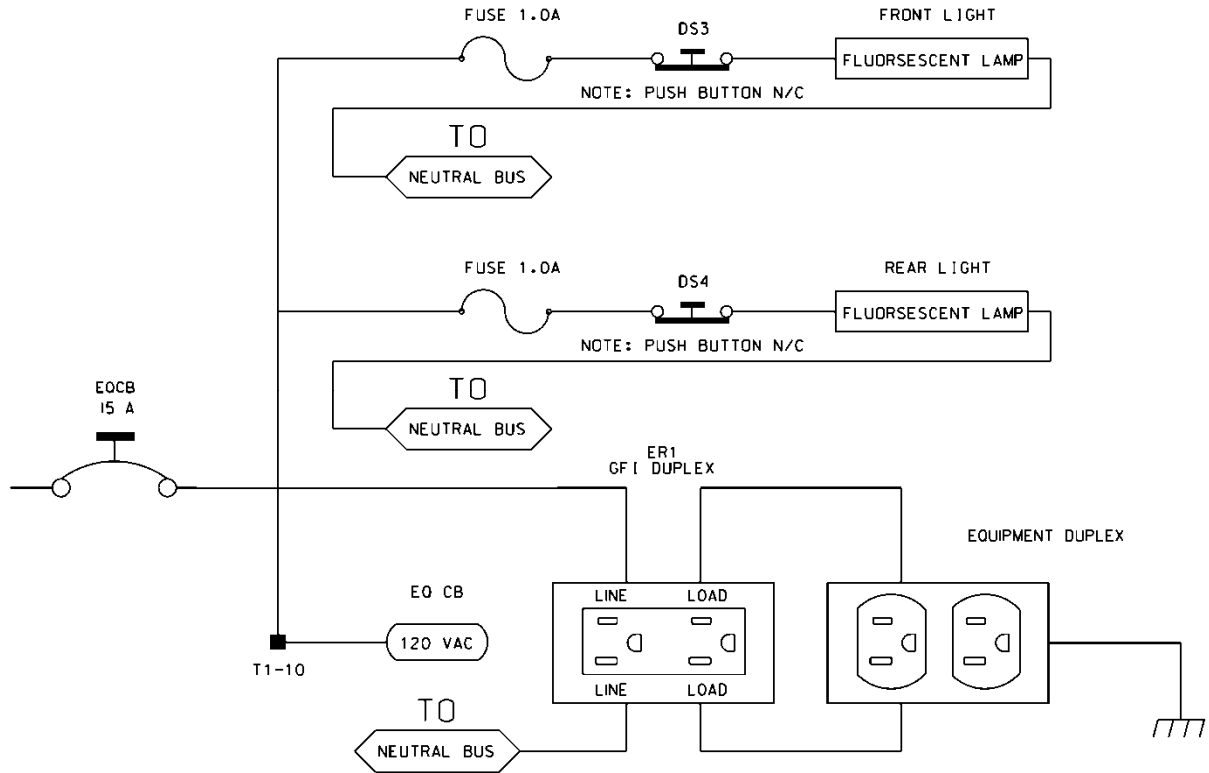

Furnish a police panel with a police panel door. For model 336S cabinets, mount the police panel on the rear door. Ensure that the police panel door permits access to the police panel when the main door is closed. Ensure that no rainwater can enter the cabinet even with the police panel door open. Provide a police panel door hinged on the right side as viewed from the front. Provide a police panel door lock that is keyed to a standard police/fire call box key. In addition to the requirements of LA Specification No. 54-053-08, provide the police panel with a toggle switch connected to switch the intersection operation between normal stop-and-go operation (AUTO) and manual operation (MANUAL). Ensure that manual control can be implemented using inputs and software such that the controller provides full programmed clearance times for the yellow clearance and red clearance for each phase while under manual control.

Provide a 1/4-inch locking phone jack in the police panel for a hand control to manually control the intersection. Provide sufficient room in the police panel for storage of a hand control and cord.

Ensure the 336S cabinet Input File is wired as follows:

336S Cabinet														
Port-Bit/C-1 Pin Assignment														
Slot #	1	2	3	4	5	6	7	8	9	10	11	12	13	14
C-1 (Spares)	59	60	61	62	63	64	65	66	75	76	77	78	79	80
Port	3-2	1-1	3-4	1-3	3-1	1-2	3-3	1-4	2-5	5-5	5-6	5-1	5-2	6-7
C-1	56	39	58	41	55	40	57	42	51	71	72	67	68	81
Port	2-1	1-5	2-3	1-7	2-2	1-6	2-4	1-8	2-6	5-7	5-8	5-3	5-4	6-8
C-1	47	43	49	45	48	44	50	46	52	73	74	69	70	82

For model 332 base mounted cabinets, ensure terminals J14-E and J14-K are wired together on the rear of the Input File. Connect TB9-12 (J14 Common) on the Input Panel to T1-2 (AC-) on the rear of the PDA.

Provide detector test switches mounted at the top of the cabinet rack or other convenient location which may be used to place a call on each of eight phases based on the chart below. Provide three positions for each switch: On (place call), Off (normal detector operation), and Momentary On (place momentary call and return to normal detector operation after switch is released). Ensure that the switches are located such that the technician can read the controller display and observe the intersection.

Connect detector test switches for cabinets as follows:

336S Cabinet		332 Cabinet	
Detector Call Switches	Terminals	Detector Call Switches	Terminals
Phase 1	I1-F	Phase 1	I1-W
Phase 2	I2-F	Phase 2	I4-W
Phase 3	I3-F	Phase 3	I5-W
Phase 4	I4-F	Phase 4	I8-W
Phase 5	I5-F	Phase 5	J1-W
Phase 6	I6-F	Phase 6	J4-W
Phase 7	I7-F	Phase 7	J5-W
Phase 8	I8-F	Phase 8	J8-W

Provide the PCB 28/56 connector for the conflict monitor unit (CMU) with 28 independent contacts per side, dual-sided with 0.156 inch contact centers. Provide the PCB 28/56 connector contacts with solder eyelet terminations. Ensure all connections to the PCB 28/56 connector are soldered to the solder eyelet terminations.

Ensure that all cabinets have the CMU connector wired according to the 332 cabinet connector pin assignments (include all wires for auxiliary output file connection). Wire pins 13, 16, R, and U of the CMU connector to a separate 4 pin plug, P1, as shown below. Provide a second plug, P2, which will mate with P1 and is wired to the auxiliary output file as shown below. Provide an additional plug, P3, which will mate with P1 and is wired to the pedestrian yellow circuits as shown

below. When no auxiliary output file is installed in the cabinet, provide wires for the green and yellow inputs for channels 11, 12, 17, and 18, the red inputs for channels 17 and 18, and the wires for the P2 plug. Terminate the two-foot wires with ring type lugs, insulated, and bundled for optional use.

PIN	P1		P2		P3	
	FUNCTION	CONN TO	FUNCTION	CONN TO	FUNCTION	CONN TO
1	CH-9G	CMU-13	OLA-GRN	A123	2P-YEL	114
2	CH-9Y	CMU-16	OLA-YEL	A122	4P-YEL	105
3	CH-10G	CMU-R	OLB-GRN	A126	6P-YEL	120
4	CH-10Y	CMU-U	OLB-YEL	A125	8P-YEL	111

Do not provide the P20 terminal assembly (red monitor board) or red interface ribbon cable as specified in LA Specification No. 54-053-08.

Provide a P20 connector that mates with and is compatible with the red interface connector mounted on the front of the conflict monitor. Ensure that the P20 connector and the red interface connector on the conflict monitor are center polarized to ensure proper connection. Ensure that removal of the P20 connector will cause the conflict monitor to recognize a latching fault condition and place the cabinet into flashing operation.

Wire the P20 connector to the output file and auxiliary output file using 22 AWG stranded wires. Ensure the length of these wires is a minimum of 42 inches in length. Provide a durable braided sleeve around the wires to organize and protect the wires.

Wire the P20 connector to the traffic signal red displays to provide inputs to the conflict monitor as shown below. Ensure the pedestrian Don't Walk circuits are wired to channels 13 through 16 of the P20 connector. When no auxiliary output file is installed in the cabinet, provide wires for channels 9 through 12 reds. Provide a wire for special function 1. Terminate the unused wires with ring type lugs, insulated, and bundled for optional use.

P20 Connector					
PIN	FUNCTION	CONN TO	PIN	FUNCTION	CONN TO
1	Channel 15 Red	119	2	Channel 16 Red	110
3	Channel 14 Red	104	4	Chassis GND	01-9
5	Channel 13 Red	113	6	N/C	
7	Channel 12 Red	AUX 101	8	Spec Function 1	
9	Channel 10 Red	AUX 124	10	Channel 11 Red	AUX 114
11	Channel 9 Red	AUX 121	12	Channel 8 Red	107
13	Channel 7 Red	122	14	Channel 6 Red	134
15	Channel 5 Red	131	16	Channel 4 Red	101
17	Channel 3 Red	116	18	Channel 2 Red	128
19	Channel 1 Red	125	20	Red Enable	01-14



Ensure the controller unit outputs to the auxiliary output file are pre-wired to the C5 connector. When no auxiliary output file is installed in the cabinet, connect the C5 connector to a storage socket located on the Input Panel or on the rear of the PDA.

Do not wire pin 12 of the load switch sockets.

In addition to the requirements of LA Specification No. 54-053-08, ensure relay K1 on the Power Distribution Assembly (PDA) is a four pole relay and K2 on the PDA is a two pole relay.

Provide a two pole, ganged circuit breaker for the flash bus circuit. Ensure the flash bus circuit breaker is an inverse time circuit breaker rated for 10 amps at 120 VAC with a minimum of 10,000 RMS symmetrical amperes short circuit current rating. Do not provide the auxiliary switch feature on the flash bus circuit breaker. Ensure the ganged flash bus circuit breaker is certified by the circuit breaker manufacturer to provide gung tripping operation.

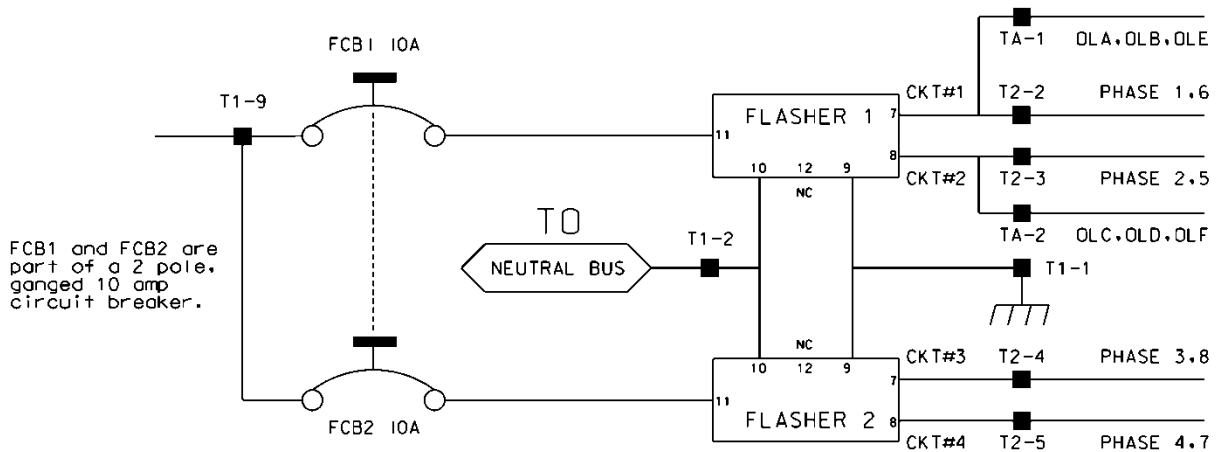

Ensure auxiliary output files are wired as follows:

AUXILIARY OUTPUT FILE TERMINAL BLOCK TA ASSIGNMENTS	
POSITION	FUNCTION
1	Flasher Unit #1, Circuit 1/FTR1 (OLA, OLB)/FTR3 (OLE)
2	Flasher Unit #1, Circuit 2/FTR2 (OLC, OLD)/FTR3 (OLF)
3	Flash Transfer Relay Coils
4	AC -
5	Power Circuit 5
6	Power Circuit 5
7	Equipment Ground Bus
8	NC

Provide four spare load resistors mounted in each cabinet. Ensure each load resistor is rated as shown in the table below. Wire one side of each load resistor to AC-. Connect the other side of each resistor to a separate terminal on a four (4) position terminal block. Mount the load resistors and terminal block either inside the back of Output File No. 1 or on the upper area of the Service Panel.

ACCEPTABLE LOAD RESISTOR VALUES	
VALUE (ohms)	WATTAGE
1.5K – 1.9 K	25W (min)
2.0K – 3.0K	10W (min)

Provide Model 200 load switches, Model 204 flashers, Model 242 DC isolators, Model 252 AC isolators, and Model 206L power supply units that conform to CALTRANS’ *“Transportation Electrical Equipment Specifications”* dated March 12, 2009 with Erratum 1.

**C. Type 170 E Cabinet Physical Requirements:**

Do not mold, cast, or scribe the name “City of Los Angeles” on the outside of the cabinet door as specified in LA Specification No. 54-053-08. Do not provide a Communications Terminal Panel as specified in LA Specification No. 54-053-08. Do not provide terminal block TBB on the Service Panel. Do not provide Cabinet Verification Test Program software or associated test jigs as specified in LA Specification No. 54-053-08.

Furnish unpainted, natural, aluminum cabinet shells. Ensure that all non-aluminum hardware on the cabinet is stainless steel or a Department approved non-corrosive alternate.

Ensure the lifting eyes, gasket channels, police panel, and all supports welded to the enclosure and doors are fabricated from 0.125 inch minimum thickness aluminum sheet and meet the same standards as the cabinet and doors.

Provide front and rear doors with latching handles that allow padlocking in the closed position. Furnish 0.75 inch minimum diameter stainless steel handles with a minimum 0.5 inch shank. Place

**U-3422A****TS-19*****Cumberland County***

the padlocking attachment at 4.0 inches from the handle shank center to clear the lock and key. Provide an additional 4.0 inches minimum gripping length.

Provide Corbin #2 locks on the front and rear doors. Provide one (1) Corbin #2 and one (1) police master key with each cabinet. Ensure main door locks allow removal of keys in the locked position only.

Provide a surge protection panel with 16 loop surge protection devices and designed to allow sufficient free space for wire connection/disconnection and surge protection device replacement. For model 332 cabinets, provide an additional 20 loop surge protection devices. Provide an additional two AC+ interconnect surge devices to protect one slot and eight DC surge protection devices to protect four slots. Provide no protection devices on slot I14.

For pole mounted cabinets, mount surge protection devices for the AC+ interconnect inputs, inductive loop detector inputs, and low voltage DC inputs on a swing down panel assembly fabricated from sturdy aluminum. Attach the swing down panel to the bottom rear cabinet rack assembly using thumb screws. Ensure the swing down panel allows for easy removal of the input file without removing the surge protection panel assembly or its parts. Have the surge protection devices mounted horizontally on the panel and soldered to the feed through terminals of four 14 position terminal blocks with #8 screws mounted on the other side. Ensure the top row of terminals is connected to the upper slots and the bottom row of terminals is connected to the bottom slots. Provide a 15 position copper equipment ground bus attached to the field terminal side (outside) of the swing down panel for termination of loop lead-in shield grounds. Ensure that a Number 4 AWG green wire connects the surge protection panel assembly ground bus to the main cabinet equipment ground.

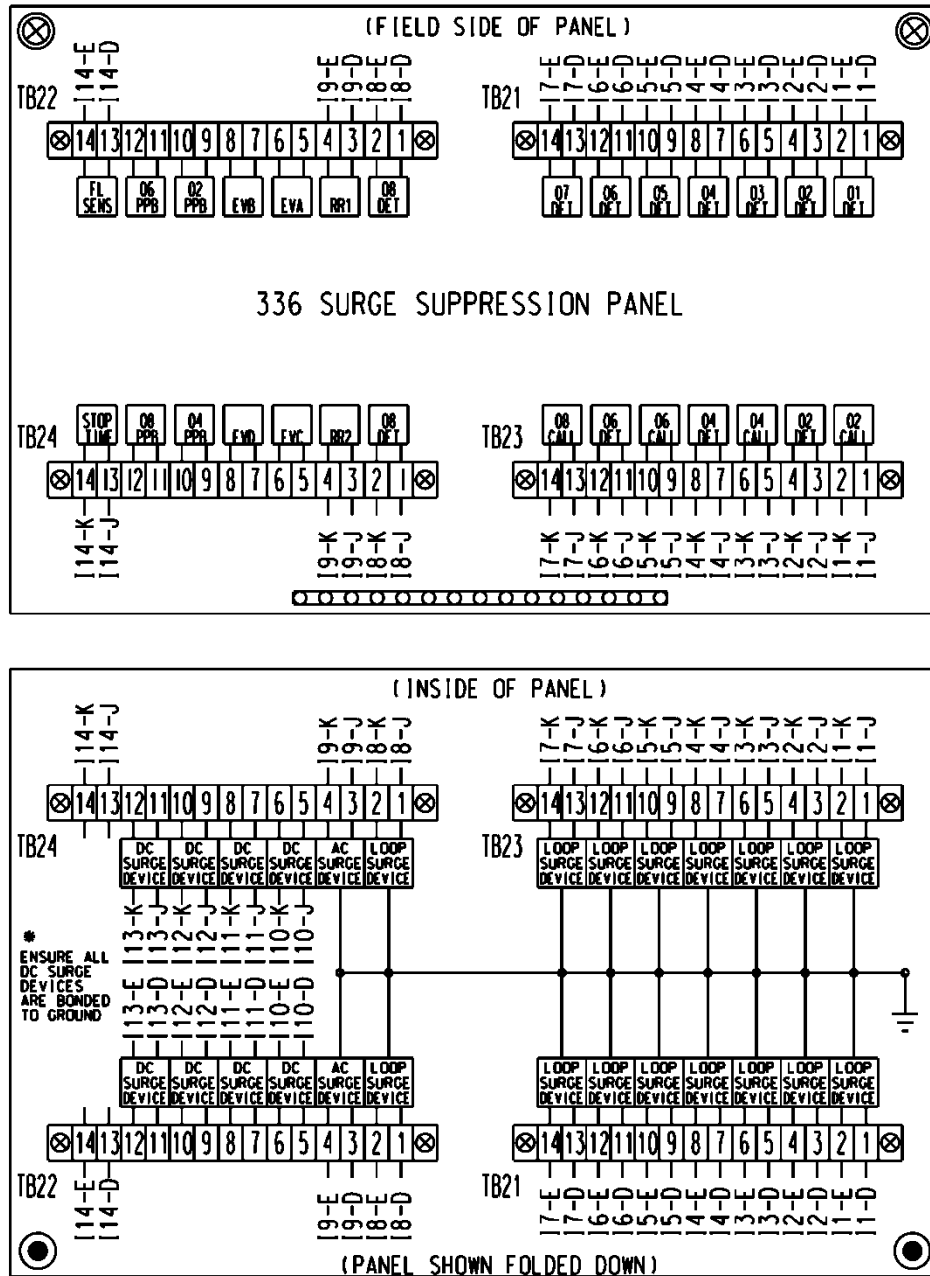

For base mounted cabinets, mount surge protection panels on the left side of the cabinet as viewed from the rear. Attach each panel to the cabinet rack assembly using bolts and make it easily removable. Mount the surge protection devices in vertical rows on each panel and connect the devices to one side of 12 position, double row terminal blocks with #8 screws. For each surge protection panel, terminate all grounds from the surge protection devices on a copper equipment ground bus attached to the surge protection panel. Wire the terminals to the rear of a standard input file using spade lugs for input file protection.

Provide permanent labels that indicate the slot and the pins connected to each terminal that may be viewed from the rear cabinet door. Label and orient terminals so that each pair of inputs is next to each other. Indicate on the labeling the input file (I or J), the slot number (1-14) and the terminal pins of the input slots (either D & E for upper or J & K for lower).

Provide a minimum 14 x 16 inch pull out, hinged top shelf located immediately below controller mounting section of the cabinet. Ensure the shelf is designed to fully expose the table surface outside the controller at a height approximately even with the bottom of the controller. Ensure the shelf has a storage bin interior which is a minimum of 1 inch deep and approximately the same dimensions as the shelf. Provide an access to the storage area by lifting the hinged top of the shelf. Fabricate the shelf and slide from aluminum or stainless steel and ensure the assembly can support the 2070L controller plus 15 pounds of additional weight. Ensure shelf has a locking mechanism to secure it in the fully extended position and does not inhibit the removal of the 2070L controller or removal of cards inside the controller when fully extended. Provide a locking mechanism that is easily released when the shelf is to be returned to its non-use position directly under the controller.

#### **D. Model 2018 Enhanced Conflict Monitor:**

Furnish Model 2018 Enhanced Conflict Monitors that provide monitoring of 18 channels. Ensure each channel consists of a green, yellow, and red field signal input. Ensure that the conflict monitor meets or exceeds CALTRANS' Transportation Electrical Equipment Specifications dated March 12, 2009, with Erratum 1 (hereafter referred to as CALTRANS' 2009 TEES) for a model 210 monitor unit and other requirements stated in this specification.

Ensure the conflict monitor is provided with an 18 channel conflict programming card. Pin EE and Pin T of the conflict programming card shall be connected together. Pin 16 of the conflict programming card shall be floating. Ensure that the absence of the conflict programming card will cause the conflict monitor to trigger (enter into fault mode), and remain in the triggered state until the programming card is properly inserted and the conflict monitor is reset.

Provide a conflict monitor that incorporates LED indicators into the front panel to dynamically display the status of the monitor under normal conditions and to provide a comprehensive review of field inputs with monitor status under fault conditions. Ensure that the monitor indicates the channels that were active during a conflict condition and the channels that experienced a failure for all other per channel fault conditions detected. Ensure that these indications and the status of each channel are retained until the Conflict Monitor is reset. Furnish LED indicators for the following:

- AC Power (Green LED indicator)
- VDC Failed (Red LED indicator)
- WDT Error (Red LED indicator)
- Conflict (Red LED indicator)
- Red Fail (Red LED indicator)
- Dual Indication (Red LED indicator)
- Yellow/Clearance Failure (Red LED indicator)
- PCA/PC Ajar (Red LED indicator)
- Monitor Fail/Diagnostic Failure (Red LED indicator)
- 54 Channel Status Indicators (1 Red, 1 Yellow, and 1 Green LED indicator for each of the 18 channels)

Provide a switch to set the Red Fail fault timing. Ensure that when the switch is in the ON position the Red Fail fault timing value is set to 1350 +/- 150 ms (2018 mode). Ensure that when the switch is in the OFF position the Red Fail fault timing value is set to 850 +/- 150 ms (210 mode).

Provide a switch to set the Watchdog fault timing. Ensure that when the switch is in the ON position the Watchdog fault timing value is set to 1.0 +/- 0.1 s (2018 mode). Ensure that when the switch is in the OFF position the Watchdog fault timing value is set to 1.5 +/- 0.1 s (210 mode).

Provide a jumper or switch to set the AC line brown-out levels. Ensure that when the jumper is present or the switch is in the ON position the AC line dropout voltage threshold is 98 +/- 2 Vrms, the AC line restore voltage threshold is 103 +/- 2 Vrms, and the AC line brown-out timing value is set to 400 +/- 50ms (2018 mode). Ensure that when the jumper is not present or the switch is in the OFF position the AC line dropout voltage threshold is 92 +/- 2 Vrms, the AC line restore voltage threshold is 98 +/- 2 Vrms, and the AC line brown-out timing value is set to 80 +/- 17 ms (210 mode).

Provide a jumper or switch that will enable and disable the Watchdog Latch function. Ensure that when the jumper is not present or the switch is in the OFF position the Watchdog Latch function is disabled. In this mode of operation, a Watchdog fault will be reset following a power loss, brownout, or power interruption. Ensure that when the jumper is present or the switch is in the ON position the Watchdog Latch function is enabled. In this mode of operation, a Watchdog fault will be retained until a Reset command is issued.

Provide a jumper that will reverse the active polarity for pin #EE (output relay common). Ensure that when the jumper is not present pin #EE (output relay common) will be considered 'Active' at a voltage greater than 70 Vrms and 'Not Active' at a voltage less than 50 Vrms (Caltrans mode). Ensure that when the jumper is present pin #EE (output relay common) will be considered 'Active' at a voltage less than 50 Vrms and 'Not Active' at a voltage greater than 70 Vrms (Failsafe mode).

In addition to the connectors required by CALTRANS' 2009 TEES, provide the conflict monitor with a red interface connector mounted on the front of the monitor. Ensure the connector is a 20 pin, right angle, center polarized, male connector with latching clip locks and polarizing keys. Ensure the right angle solder tails are designed for a 0.062" thick printed circuit board. Keying of the connector shall be between pins 3 and 5, and between 17 and 19. Ensure the connector has two rows of pins with the odd numbered pins on one row and the even pins on the other row. Ensure the connector pin row spacing is 0.10" and pitch is 0.10". Ensure the mating length of the connector pins is 0.24". Ensure the pins are finished with gold plating 30μ" thick.

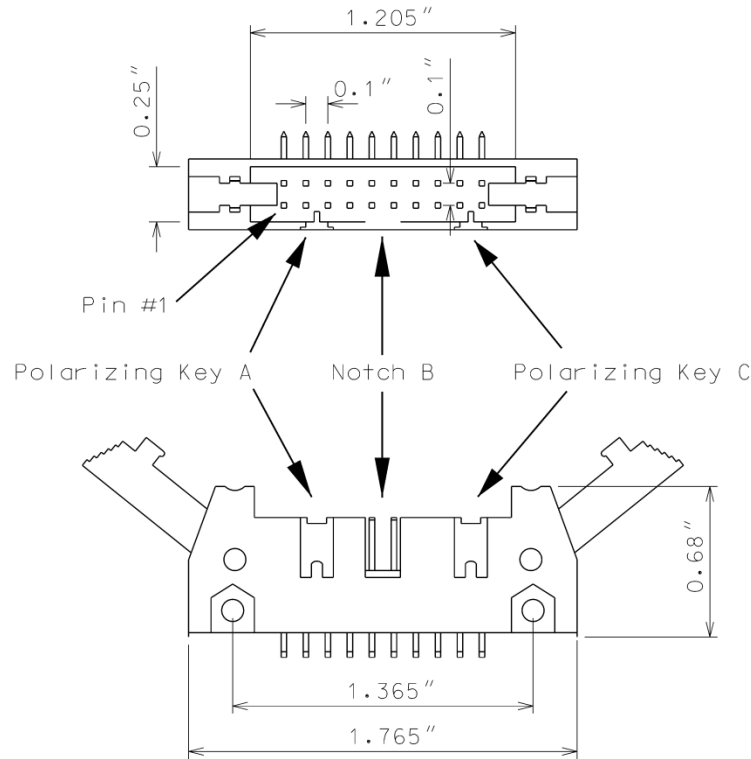

Ensure the red interface connector pins on the monitor have the following functions:

Pin #	Function	Pin #	Function
1	Channel 15 Red	2	Channel 16 Red
3	Channel 14 Red	4	Chassis Ground
5	Channel 13 Red	6	Special Function 2
7	Channel 12 Red	8	Special Function 1
9	Channel 10 Red	10	Channel 11 Red
11	Channel 9 Red	12	Channel 8 Red
13	Channel 7 Red	14	Channel 6 Red
15	Channel 5 Red	16	Channel 4 Red
17	Channel 3 Red	18	Channel 2 Red
19	Channel 1 Red	20	Red Enable

Ensure that removal of the P20 cable connector will cause the conflict monitor to recognize a latching fault condition and place the cabinet into flashing operation.

Provide Special Function 1 and Special Function 2 inputs to the unit which shall disable only Red Fail Monitoring when either input is sensed active. A Special Function input shall be sensed active when the input voltage exceeds 70 Vrms with a minimum duration of 550 ms. A Special Function input shall be sensed not active when the input voltage is less than 50 Vrms or the duration is less

than 250 ms. A Special Function input is undefined by these specifications and may or may not be sensed active when the input voltage is between 50 Vrms and 70 Vrms or the duration is between 250 ms and 550 ms.

Ensure the conflict monitor recognizes field signal inputs for each channel that meet the following requirements:

- consider a Red input greater than 70 Vrms and with a duration of at least 500 ms as an “on” condition;
- consider a Red input less than 50 Vrms or with a duration of less than 200 ms as an “off” condition (no valid signal);
- consider a Red input between 50 Vrms and 70 Vrms or with a duration between 200 ms and 500 ms to be undefined by these specifications;
- consider a Green or Yellow input greater than 25 Vrms and with a duration of at least 500 ms as an “on” condition;
- consider a Green or Yellow input less than 15 Vrms or with a duration of less than 200 ms as an “off” condition; and
- consider a Green or Yellow input between 15 Vrms and 25 Vrms or with a duration between 200 ms and 500 ms to be undefined by these specifications.

Provide a conflict monitor that recognizes the faults specified by CALTRANS’ 2009 TEES and the following additional faults. Ensure the conflict monitor will trigger upon detection of a fault and will remain in the triggered (in fault mode) state until the unit is reset at the front panel or through the external remote reset input for the following failures:

1. **Red Monitoring or Absence of Any Indication (Red Failure):** A condition in which no “on” voltage signal is detected on any of the green, yellow, or red inputs to a given monitor channel. If a signal is not detected on at least one input (R, Y, or G) of a conflict monitor channel for a period greater than 1000 ms when used with a 170 controller and 1500 ms when used with a 2070 controller, ensure monitor will trigger and put the intersection into flash. If the absence of any indication condition lasts less than 700 ms when used with a 170 controller and 1200 ms when used with a 2070 controller, ensure conflict monitor will not trigger. Red fail monitoring shall be enabled on a per channel basis by the use of switches located on the conflict monitor. Have red monitoring occur when all of the following input conditions are in effect:
  - a) Red Enable input to monitor is active (Red Enable voltages are “on” at greater than 70 Vrms, off at less than 50 Vrms, undefined between 50 and 70 Vrms), and
  - b) Neither Special Function 1 nor Special Function 2 inputs are active.
  - c) Pin #EE (output relay common) is not active
2. **Short/Missing Yellow Indication Fault (Clearance Error):** Yellow indication following a green is missing or shorter than 2.7 seconds (with  $\pm 0.1$ -second accuracy). If a channel fails to detect an “on” signal at the Yellow input for a minimum of 2.7 seconds ( $\pm 0.1$  second) following the detection of an “on” signal at a Green input for that channel, ensure that the monitor triggers and generates a clearance/short yellow error fault indication. Short/missing



yellow (clearance) monitoring shall be enabled on a per channel basis by the use of switches located on the conflict monitor. This fault shall not occur when the channel is programmed for Yellow Inhibit, when the Red Enable signal is inactive or pin #EE (output relay common) is active.

3. **Dual Indications on the Same Channel:** In this condition, more than one indication (R,Y,G) is detected as “on” at the same time on the same channel. If dual indications are detected for a period greater than 500 ms, ensure that the conflict monitor triggers and displays the proper failure indication (Dual Ind fault). If this condition is detected for less than 200 ms, ensure that the monitor does not trigger. G-Y-R dual indication monitoring shall be enabled on a per channel basis by the use of switches located on the conflict monitor. G-Y dual indication monitoring shall be enabled for all channels by use of a switch located on the conflict monitor. This fault shall not occur when the Red Enable signal is inactive or pin #EE (output relay common) is active.
4. **Configuration Settings Change:** The configuration settings are comprised of (as a minimum) the permissive diode matrix, dual indication switches, yellow disable jumpers, any option switches, any option jumpers, and the Watchdog Enable switch. Ensure the conflict monitor compares the current configuration settings with the previous stored configuration settings on power-up, on reset, and periodically during operation. If any of the configuration settings are changed, ensure that the conflict monitor triggers and causes the program card indicator to flash. Ensure that configuration change faults are only reset by depressing and holding the front panel reset button for a minimum of three seconds. Ensure the external remote reset input does not reset configuration change faults.

Ensure the conflict monitor will trigger and the AC Power indicator will flash at a rate of  $2 \text{ Hz} \pm 20\%$  with a 50% duty cycle when the AC Line voltage falls below the “drop-out” level. Ensure the conflict monitor will resume normal operation when the AC Line voltage returns above the “restore” level. Ensure the AC Power indicator will remain illuminated when the AC voltage returns above the “restore” level. Should an AC Line power interruption occur while the monitor is in the fault mode, then upon restoration of AC Line power, the monitor will remain in the fault mode and the correct fault and channel indicators will be displayed.

Provide a flash interval of at least 6 seconds and at most 16 seconds in duration following a power-up, an AC Line interruption, or a brownout restore. Ensure the conflict monitor will suspend all fault monitoring functions, close the Output relay contacts, and flash the AC indicator at a rate of  $4 \text{ Hz} \pm 20\%$  with a 50% duty cycle during this interval. Ensure the termination of the flash interval after at least 6 seconds if the Watchdog input has made 5 transitions between the True and False state and the AC Line voltage is greater than the “restore” level. If the watchdog input has not made 5 transitions between the True and False state within  $10 \pm 0.5$  seconds, the monitor shall enter a WDT error fault condition.

Ensure the conflict monitor will monitor an intersection with a minimum of four approaches using the four-section Flashing Yellow Arrow (FYA) vehicle traffic signal as outlined by the NCHRP 3-54 research project for protected-permissive left turn signal displays. Ensure the conflict monitor will operate in the FYA mode and FYAc (Compact) mode as specified below to monitor each channel pair for the following fault conditions: Conflict, Flash Rate Detection, Red Fail, Dual Indication, and

Clearance. Provide a switch to select between the FYA mode and FYAc mode. Provide a switch to select each FYA phase movement for monitoring.

**FYA mode**

FYA Signal Head	Phase 1	Phase 3	Phase 5	Phase 7
Red Arrow	Channel 9 Red	Channel 10 Red	Channel 11 Red	Channel 12 Red
Yellow Arrow	Channel 9 Yellow	Channel 10 Yellow	Channel 11 Yellow	Channel 12 Yellow
Flashing Yellow Arrow	Channel 9 Green	Channel 10 Green	Channel 11 Green	Channel 12 Green
Green Arrow	Channel 1 Green	Channel 3 Green	Channel 5 Green	Channel 7 Green

**FYAc mode**

FYA Signal Head	Phase 1	Phase 3	Phase 5	Phase 7
Red Arrow	Channel 1 Red	Channel 3 Red	Channel 5 Red	Channel 7 Red
Yellow Arrow	Channel 1 Yellow	Channel 3 Yellow	Channel 5 Yellow	Channel 7 Yellow
Flashing Yellow Arrow	Channel 1 Green	Channel 3 Green	Channel 5 Green	Channel 7 Green
Green Arrow	Channel 9 Green	Channel 9 Yellow	Channel 10 Green	Channel 10 Yellow

If a FYA channel pair is enabled for FYA operation, the conflict monitor will monitor the FYA logical channel pair for the additional following conditions:

1. **Conflict:** Channel conflicts are detected based on the permissive programming jumpers on the program card. This operation remains unchanged from normal operation except for the solid Yellow arrow (FYA clearance) signal.
2. **Yellow Change Interval Conflict:** During the Yellow change interval of the Permissive Turn channel (flashing Yellow arrow) the conflict monitor shall verify that no conflicting channels to the solid Yellow arrow channel (clearance) are active. These conflicting channels shall be determined by the program card compatibility programming of the Permissive Turn channel (flashing Yellow arrow). During the Yellow change interval of the Protected Turn channel (solid Green arrow) the conflict monitor shall verify that no conflicting channels to the solid Yellow arrow channel (clearance) are active as determined by the program card compatibility programming of the Protected Turn channel (solid Green arrow).

3. **Flash Rate Detection:** The conflict monitor unit shall monitor for the absence of a valid flash rate for the Permissive turn channel (flashing Yellow arrow). If the Permissive turn channel (flashing Yellow arrow) is active for a period greater than 1600 milliseconds, ensure the conflict monitor triggers and puts the intersection into flash. If the Permissive turn channel (flashing Yellow arrow) is active for a period less than 1400 milliseconds, ensure the conflict monitor does not trigger. Ensure the conflict monitor will remain in the triggered (in fault mode) state until the unit is reset at the front panel or through the external remote reset input. Provide a jumper or switch that will enable and disable the Flash Rate Detection function. Ensure that when the jumper is not present or the switch is in the OFF position the Flash Rate Detection function is enabled. Ensure that when the jumper is present or the switch is in the ON position the Flash Rate Detection function is disabled.
4. **Red Monitoring or Absence of Any Indication (Red Failure):** The conflict monitor unit shall detect a red failure if there is an absence of voltage on all four of the inputs of a FYA channel pair (RA, YA, FYA, GA).
5. **Dual Indications on the Same Channel:** The conflict monitor unit shall detect a dual indication if two or more inputs of a FYA channel pair (RA, YA, FYA, GA) are “on” at the same time.
6. **Short/Missing Yellow Indication Fault (Clearance Error):** The conflict monitor unit shall monitor the solid Yellow arrow for a clearance fault when terminating both the Protected Turn channel (solid Green arrow) interval and the Permissive Turn channel (flashing Yellow arrow) interval.

Ensure that the conflict monitor will log at least nine of the most recent events detected by the monitor in non-volatile EEPROM memory (or equivalent). For each event, record at a minimum the time, date, type of event, status of each field signal indication with RMS voltage, and specific channels involved with the event. Ensure the conflict monitor will log the following events: monitor reset, configuration, previous fault, and AC line. Furnish the signal sequence log that shows all channel states (Greens, Yellows, and Reds) and the Red Enable State for a minimum of 2 seconds prior to the current fault trigger point. Ensure the display resolution of the inputs for the signal sequence log is not greater than 50 ms.

For conflict monitors used within an Ethernet communications system, provide a conflict monitor with an Ethernet 10/100 Mbps, RJ-45 port for data communication access to the monitor by a local notebook computer and remotely via a workstation or notebook computer device connected to the signal system local area network. The Ethernet port shall be electrically isolated from the conflict monitor’s electronics and shall provide a minimum of 1500 Vrms isolation. Integrate monitor with Ethernet network in cabinet. Provide software to retrieve the time and date from a network server in order to synchronize the on-board times between the conflict monitor and the controller. Furnish and install the following Windows based, graphic user interface software on workstations and notebook computers where the signal system client software is installed: 1) software to view and retrieve all event log information, 2) software that will search and display a list of conflict monitor IP addresses and IDs on the network, and 3) software to change the conflict monitor’s network parameters such as IP address and subnet mask.

For non-Ethernet connected monitors, provide a RS-232C/D compliant port (DB-9 female connector) on the front panel of the conflict monitor in order to provide communications from the conflict monitor to the 170/2070 controller or to a Department-furnished laptop computer. Electrically isolate the port interface electronics from all monitor electronics, excluding Chassis Ground. Ensure that the controller can receive all event log information through a controller

**U-3422A**

**TS-28**

*Cumberland County*

Asynchronous Communications Interface Adapter (Type 170E) or Async Serial Comm Module (2070). Furnish and connect a serial cable from the conflict monitor’s DB-9 connector to Comm Port 1 of the 2070 controller. Ensure conflict monitor communicates with the controller. Provide a Windows based graphic user interface software to communicate directly through the same monitor RS-232C/D compliant port to retrieve and view all event log information to a Department-furnished laptop computer. The RS-232C/D compliant port on the monitor shall allow the monitor to function as a DCE device with pin connections as follows:

<b>Conflict Monitor RS-232C/D (DB-9 Female) Pinout</b>		
<b>Pin Number</b>	<b>Function</b>	<b>I/O</b>
1	DCD	O
2	TX Data	O
3	RX Data	I
4	DTR	I
5	Ground	-
6	DSR	O
7	CTS	I
8	RTS	O
9	NC	-

U-3422A

TS-29

Cumberland County

---

**MONITOR BOARD EDGE CONNECTOR**

---

<b>Pin #</b>	<b>Function (Back Side)</b>	<b>Pin #</b>	<b>Function (Component Side)</b>
1	Channel 2 Green	A	Channel 2 Yellow
2	Channel 13 Green	B	Channel 6 Green
3	Channel 6 Yellow	C	Channel 15 Green
4	Channel 4 Green	D	Channel 4 Yellow
5	Channel 14 Green	E	Channel 8 Green
6	Channel 8 Yellow	F	Channel 16 Green
7	Channel 5 Green	H	Channel 5 Yellow
8	Channel 13 Yellow	J	Channel 1 Green
9	Channel 1 Yellow	K	Channel 15 Yellow
10	Channel 7 Green	L	Channel 7 Yellow
11	Channel 14 Yellow	M	Channel 3 Green
12	Channel 3 Yellow	N	Channel 16 Yellow
13	Channel 9 Green	P	Channel 17 Yellow
14	Channel 17 Green	R	Channel 10 Green
15	Channel 11 Yellow	S	Channel 11 Green
16	Channel 9 Yellow	T	Channel 18 Yellow
17	Channel 18 Green	U	Channel 10 Yellow
--		--	
18	Channel 12 Yellow	V	Channel 12 Green
19	Channel 17 Red	W	Channel 18 Red
20	Chassis Ground	X	Not Assigned
21	AC-	Y	DC Common
22	Watchdog Timer	Z	External Test Reset
23	+24VDC	AA	+24VDC
24	Tied to Pin 25	BB	Stop Time (Output)
25	Tied to Pin 24	CC	Not Assigned
26	Not Assigned	DD	Not Assigned
27	Relay Output, Side #3, N.O.	EE	Relay Output, Side #2, Common
28	Relay Output, Side #1, N.C.	FF	AC+

-- Slotted for keying between Pins 17/U and 18/V

**CONFLICT PROGRAM CARD PIN ASSIGNMENTS**

<b>Pin #</b>	<b>Function (Back Side)</b>	<b>Pin #</b>	<b>Function (Component Side)</b>
1	Channel 2 Green	A	Channel 1 Green
2	Channel 3 Green	B	Channel 2 Green
3	Channel 4 Green	C	Channel 3 Green
4	Channel 5 Green	D	Channel 4 Green
5	Channel 6 Green	E	Channel 5 Green
6	Channel 7 Green	F	Channel 6 Green
7	Channel 8 Green	H	Channel 7 Green
8	Channel 9 Green	J	Channel 8 Green
9	Channel 10 Green	K	Channel 9 Green
10	Channel 11 Green	L	Channel 10 Green
11	Channel 12 Green	M	Channel 11 Green
12	Channel 13 Green	N	Channel 12 Green
13	Channel 14 Green	P	Channel 13 Green
14	Channel 15 Green	R	Channel 14 Green
15	Channel 16 Green	S	Channel 15 Green
16	N/C	T	PC AJAR
17	Channel 1 Yellow	U	Channel 9 Yellow
18	Channel 2 Yellow	V	Channel 10 Yellow
19	Channel 3 Yellow	W	Channel 11 Yellow
20	Channel 4 Yellow	X	Channel 12 Yellow
21	Channel 5 Yellow	Y	Channel 13 Yellow
22	Channel 6 Yellow	Z	Channel 14 Yellow
23	Channel 7 Yellow	AA	Channel 15 Yellow
24	Channel 8 Yellow	BB	Channel 16 Yellow
--		--	
25	Channel 17 Green	CC	Channel 17 Yellow
26	Channel 18 Green	DD	Channel 18 Yellow
27	Channel 16 Green	EE	PC AJAR (Program Card)
28	Yellow Inhibit Common	FF	Channel 17 Green

-- Slotted for keying between Pins 24/BB and 25/CC

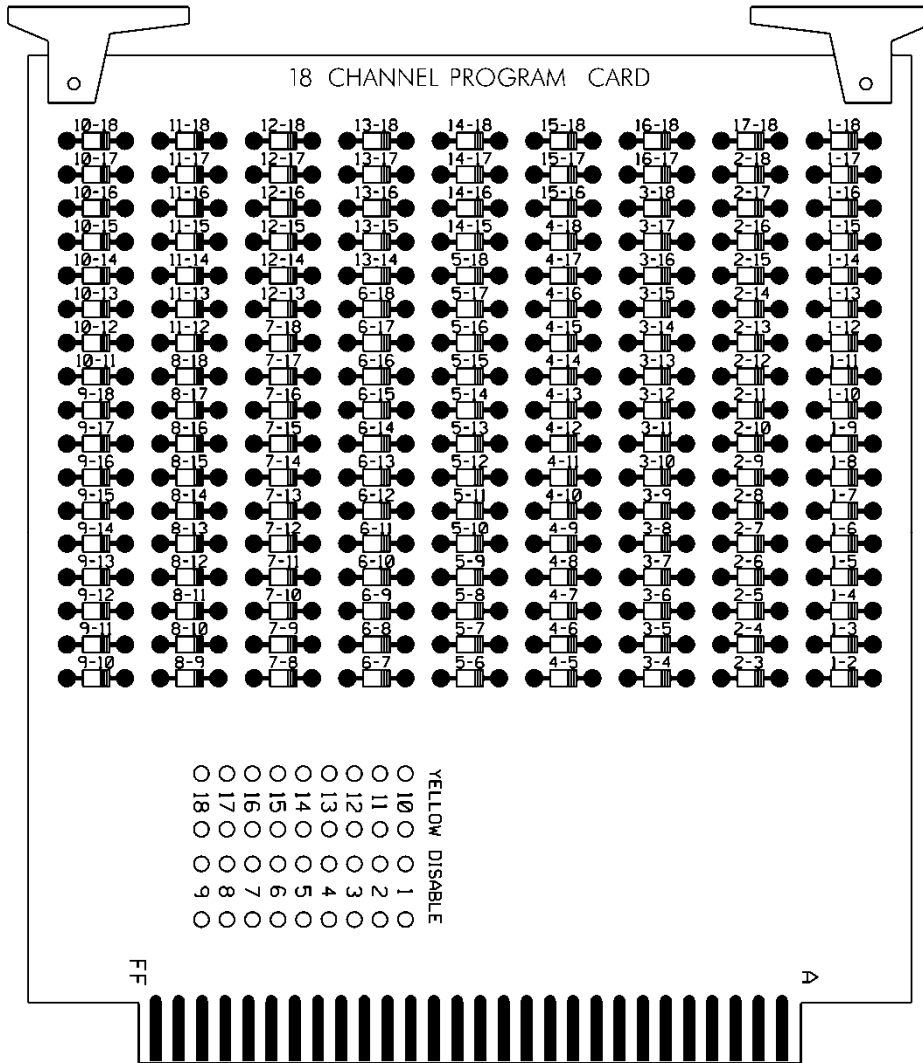

**3.4. MATERIALS – TYPE 170 DETECTOR SENSOR UNITS**

Furnish detector sensor units that comply with Chapter 5 Section 1, “General Requirements,” and Chapter 5 Section 2, “Model 222 & 224 Loop Detector Sensor Unit Requirements,” of the CALTRANS “Transportation Electrical Equipment Specifications” dated March 12, 2009 with Erratum 1.

**3.5. MEASUREMENT AND PAYMENT**

Actual number of 2070LX controller units without cabinet furnished, installed and accepted.

No measurement will be made of cables or hardware for installation or controller programming, as these will be considered incidental to furnishing and installing controller.

Payment will be made under:

2070LX Controller without cabinet .....Each

#### 4. MICROWAVE VEHICLE DETECTION SYSTEM - MULTIPLE DETECTION ZONES

##### 4.1. DESCRIPTION

Design, furnish and install a microwave vehicle detection system with the manufacturer recommended cables and hardware in accordance to the plans and specifications. Ensure the detection system provides multiple detection zones.

##### 4.2. MATERIALS

Provide design drawings showing design details and microwave sensor locations for review and acceptance before installation. Provide mounting height and location requirements for microwave sensor units on the design based on a site survey. Design microwave vehicle detection system with all necessary hardware. Indicate all necessary poles, spans, mast arms, luminaire arms, cables, microwave sensor mounting assemblies and hardware to achieve the required detection zones where Department owned poles are not adequate to locate the microwave sensor units. Do not design for the installation of poles in medians.

Obtain the Engineer's approval before furnishing microwave vehicle detection system. The contractor is responsible for the final design of microwave vehicle detection system. Review and acceptance of the designs by the Department does not relieve the contractor from the responsibility to provide fully functional systems and to ensure that the required detection zones can be provided. With the exception of contractor-furnished poles, mast arms, and luminaire arms, furnish material, equipment, and hardware under this section that is pre-approved on the ITS and Signals QPL. Submit and obtain Engineer's approval of shop drawings for any poles, mast arms, and luminaire arms provided by the contractor prior to ordering from manufacturer.

Provide a detector for either side-fire or forward-fire configuration. Ensure the detector will detect vehicles in sunny, cloudy, rainy, snowy, and foggy weather conditions. Ensure the detector can operate from the voltage supplied by a NEMA TS-1/TS-2 or Type 332 or 336 traffic signal cabinet. Ensure the detector can provide detection calls to the traffic signal controller within a NEMA TS-1/TS-2 or Type 332 or 336 cabinet. Ensure the detection system provides a constant call in the event of a component failure or loss of power. Ensure the detector has an operating temperature range of -30 to 165 degrees F and operates within the frequency range of 10 to 25 GHz. Ensure the detector is provided with a water-tight housing offering NEMA 4X protection and operates properly in up to 95% relative humidity, non-condensing.

Provide each detector unit to allow the placement of at least 8 detection zones with a minimum of 8 detection channel outputs. When the microwave vehicle detection system requires an integrated card rack interface(s), provide only enough interface cards to implement the vehicle detection shown on the signal plans. Provide a means acceptable to the Engineer to configure traffic lanes and detection zones. Provide each channel output with a programmable means to delay the output call upon activation of a detection zone that is adjustable in one second increments (maximum) over the range of 0 to 25 seconds. Provide each channel output with a programmable means to extend the output call that is adjustable in one second increments (maximum) over the range of 0 to 25 seconds. Ensure both delay and extend timing can be set for the same channel output.

For advance detection system, ensure the detector senses vehicles in motion at a range of 50 to 400 feet from the detector unit for forward-fire configuration and a range of 50 to 200 feet from the detector unit for side-fire configuration with an accuracy of 95% for both configurations. Ensure the advance detection system provides each channel output call of at least 100 ms in duration.

For stop bar presence detection system, ensure the detector outputs a constant call while a vehicle is in the detection zone and removes the call after all vehicles exit the detection zone.



Ensure the presence detector unit can cover a detection zone as shown on the plans and has an effective range of 10 to 120 feet from the detector unit.

For units without an integrated card rack interface, provide Form C output relay contacts rated a minimum of 3A, 24VDC.

If a laptop is used to adjust detector settings, ensure that software is licensed for use by the Department and by any other agency responsible for maintaining or operating the microwave detection system. Provide the Department with a license to duplicate and distribute the software as necessary for design and maintenance support.

After initial detector configuration and installation, ensure routine adjustments or calibration are not needed to maintain acceptable performance.

**4.3. CONSTRUCTION METHODS**

Install the microwave vehicle detection system in accordance with the manufacturer’s recommendations.

Monitor and maintain each detector unit during construction to ensure microwave vehicle detection system is functioning properly and aimed for the detection zone shown in the plans. Refer to Subarticle 1700-3 (D) Maintenance and Repair of Materials of the *Standard Specifications* for failure to maintain the microwave detection system.

**4.4. MEASUREMENT AND PAYMENT**

Actual number of microwave vehicle detection systems – multiple zones furnished, installed, and accepted.

No measurement will be made of cables or hardware, as these will be considered incidental to furnishing and installing microwave vehicle detection systems.

Payment will be made under:

Microwave Vehicle Detection System – Multiple Zones..... Each

**5. METAL POLE SUPPORTS**

**5.1. METAL POLES**

**A. General:**

Furnish and install metal poles, grounding systems, and all necessary hardware. Work covered under this special provision includes requirements for design, fabrication, and installation of standard and custom/site-specific designed metal pole supports and associated foundations.

Comply with applicable sections of the *2024 STANDARD SPECIFICATIONS FOR ROADS & STRUCTURES*, hereinafter referred to as the *Standard Specifications*. Provide designs of completed assemblies with hardware equaling or exceeding *AASHTO LRFD Specifications for Structural Supports for Highway Signs, Luminaires and Traffic Signals* 1<sup>st</sup> Edition, 2015 (hereinafter called 1<sup>st</sup> Edition AASHTO), including the latest interim specifications. Provide assemblies with a round or near-round (18 sides or more) cross-section, or a multi-sided cross section with no less than six sides. The sides may be straight, convex, or concave.

For bid purposes, pole heights shown on plans are estimated from available data. Prior to furnishing metal poles, use field measurements and adjusted cross-sections to determine whether pole heights will meet required clearances. If pole heights do not meet required clearances, the Contractor should immediately notify the Engineer of the required revised pole heights.

Standard Drawings for Metal Poles are available that supplement these project special provisions. The drawings are located on the Department’s website:

<https://connect.ncdot.gov/resources/safety/pages/ITS-Design-Resources.aspx>

Comply with article 1098-1(B) of the *Standard Specifications* for submittal requirements. Furnish shop drawings for approval. Provide copies of detailed shop drawings for each type of structure as summarized below. Ensure shop drawings include material specifications for each component. Ensure shop drawings identify welds by type and size on the detail drawing only, not in table format. **Do not release structures for fabrication until shop drawings have been approved by NCDOT.** Ensure shop drawings contain an itemized bill of materials for all structural components and associated connecting hardware.

Comply with article 1098-1(A) of the *Standard Specifications* for Qualified Products List (QPL) submittals. All shop drawings must include project location description, signal or asset inventory number(s) and project number or work order number.

Summary of information required for metal pole review submittal:

Item	Electronic Submittal	Comments / Special Instructions
Sealed, Approved Signal or ITS Plan/Loading Diagram	1 set	All structure design information needs to reflect the latest approved Signal or ITS plans
Custom Pole Shop Drawings	1 set	Submit drawings on 11” x 17” format media. Show NCDOT signal or asset inventory number(s), Contractor’s name and relevant revision number in the title block. All drawings must have a <u>unique drawing number</u> for each project.
Standard Strain Pole Shop Drawings (from the QPL)	1 set	Submit drawings on 11” x 17” format media. Show NCDOT signal inventory number(s), Contractor’s name and relevant revision number in the title block. All drawings must have a <u>unique drawing number</u> for each project.
Structure Calculations	1 set	Not required for Standard QPL Poles
Standard Strain Pole Foundation Drawings	1 set	Submit drawings on 11” x 17” format media. Submit a completed Standard Foundation Selection form for each pole using foundation table on Metal Pole Drawing M8.
Custom Foundation Drawings	1 set	Submit drawings on 11” x 17” format media. Show NCDOT signal or asset inventory number(s), Contractor’s name and relevant revision number in the title block. All drawings must have a <u>unique drawing number</u> for each project. If QPL Poles are used, include the corresponding QPL pole shop drawings with this submittal.
Foundation Calculations	1 set	<b>Submit copies of LPILE input, output, and pile tip deflection graph per Section titled</b>

		<p><b>Drilled Pier Foundations for Metal Poles of this specification for each foundation.</b></p> <p>Not required for Standard Strain Poles (from the QPL)</p>
Soil Boring Logs and Report	1 set	Report shall include a location plan and a soil classification report including soil capacity, water level, hammer efficiency, soil bearing pressure, soil density, etc. for each pole.

**NOTE** – All shop drawings and custom foundation design drawings must be sealed by a Professional Engineer licensed in the state of North Carolina. All geotechnical information must be sealed by either a Professional Engineer or Geologist licensed in the state of North Carolina. Include a title block and revision block on the shop drawings and foundation drawings showing the NCDOT signal or asset inventory number(s).

**Shop drawings and foundation drawings may be submitted together or separately for approval. However, shop drawings must be approved before foundations can be reviewed.** Foundation designs will be returned without review if the associated shop drawing has not been approved. Boring reports shall include the following: Engineer’s summary, boring location maps, soil classification per AASHTO Classification System, hammer efficiency, and Metal Pole Standard Foundation Selection Form. Incomplete submittals will be returned without review. The Reviewer has the right to request additional analysis and copies of the calculations to expedite the approval process.

**B. Materials:**

Fabricate metal pole from coil or plate steel that meet the requirements of ASTM A 572 Gr 55 or ASTM A 595 Grade A tubes. For structural steel shapes, plates, and bars use, as a minimum, ASTM A572 Gr 50, AASHTO M270 Gr 50, ASTM A709 Gr 50, or an approved equivalent. Provide pole shafts of round or near round (18 sides or more) cross-section, or multi-sided tubular cross-section with no less than six sides, having a uniform linear taper of 0.14 in/ft. Construct shafts from one piece of single-ply plate or coil. For anchor base fabrication, conform to the applicable bolt pattern and orientation as shown on Metal Pole Standard Drawing Sheet M2.

Use the submerged arc process, or other NCDOT previously approved process suitable for shafts, to continuously weld pole shafts along their entire length. Finish the longitudinal seam weld flush with the outside contour of the base metal. Ensure shaft has no circumferential welds except at the lower end joining the shaft to the pole base. Use full penetration groove welds with backing ring for all tube-to-transverse-plate connections in accordance with 1<sup>st</sup> Edition AASHTO. Provide welding that conforms to Article 1072-18 of the *Standard Specifications*. No field welding on any part of the pole will be permitted unless approved by a qualified Engineer.

After fabrication, hot-dip galvanize steel poles and all assembly components in accordance with section 1076-3 of the *Standard Specifications*. Design structural assemblies with weep holes large enough and properly located to drain molten zinc during the galvanization process. Galvanize hardware in accordance with section 1076-4 of the *Standard Specifications*. Ensure threaded material is brushed and retapped as necessary after galvanizing. Perform repair of damaged galvanizing in accordance with section 1076-7 of the *Standard Specifications*. *Ensure* all hardware is galvanized steel or stainless steel. The Contractor is responsible for ensuring the Designer/Fabricator specifies connecting hardware and/or materials that prevent a dissimilar metal corrosive reaction.

Ensure each anchor rod is 2-inch minimum diameter and 60-inch length. Provide 10-inch minimum thread projection at the top of the rod, and 8-inch minimum at the bottom of the rod. Use anchor rod assembly and drilled pier foundation materials complying with SP09\_R005, hereinafter referred to as *Foundations and Anchor Rod Assemblies for Metal Poles*.

Ensure anchor bolt hole diameters are ¼-inch larger than the anchor bolt diameters in the base plate.

Provide a circular anchor bolt lock plate securing the anchor bolts at the embedded end with two (2) washers and two (2) nuts. Provide a base plate template matching the bolt circle diameter of the anchor bolt lock plate. Construct plates and templates from ¼-inch minimum thick steel with a minimum width of 4 inches. Hot-dip galvanizing is not required for both plates.

Provide four (4) heavy hex nuts and four (4) flat washers for each anchor bolt. For nuts, use AASHTO M291 grade 2H, DH, or DH3 or equivalent material. For flat washers, use AASHTO M293 or equivalent material. Ensure anchor bolts have required diameters, lengths, and positions, and will develop strengths comparable to their respective poles.

For each pole, provide a grounding lug with a ½-inch minimum thread diameter, coarse thread stud and nut that will accommodate #4 AWG ground wire. Ensure the lug is electrically bonded to the pole and is conveniently located inside the pole at the hand hole.

Provide a removable pole cap with stainless steel attachment screws for the top of each pole. Ensure cap is cast aluminum conforming to Aluminum Association Alloy 356.0F. Furnish cap attached to the pole with a sturdy stainless-steel chain that is long enough to permit cap to hang clear of the pole-top opening when cap is removed.

Where required by the plans, furnish couplings 42 inches above bottom of the pole base for mounting of pedestrian pushbuttons. Provide mounting points consisting of 1½-inch internally threaded half-couplings complying with the NEC, mounted within the poles. Ensure that couplings are essentially flush with the outside surfaces of the poles and are installed before any required hot-dip galvanizing. Provide a threaded plug in each mounting point. Ensure the surface of the plug is essentially flush with the outer end of the mounting point when installed and has a recessed slot that will accommodate a ½ “drive standard socket wrench.

Metal poles may be erected and fully loaded after concrete has attained a minimum allowable compressive strength of 3,000 psi.

Connect poles to grounding electrodes and bond them to the electrical service grounding electrodes.

When field drilling is necessary for wire or cable entrances into the pole, comply with the following requirements:

- Do not drill holes within 2 inches of any welds.
- Do not drill any holes larger than 3 inches in diameter without checking with the ITS & Signals Structure Engineers.
- Avoid drilling multiple holes along the same cross section of tube shafts.
- Install rubber grommets in all field drilled holes that wire, or cable will directly enter unless holes are drilled for installation of weather heads or couplings.
- Treat the inside of the drilled holes and repair all galvanized surfaces in accordance with Section 1076-7 of the latest edition of the *Standard Specification prior to installing grommets, caps, or plugs*.

- Cap or plug any existing field drilled holes that are no longer used with rubber, aluminum, or stainless-steel hole plugs.

When street lighting is installed on metal signal structures, isolate the conductors feeding the luminaires inside the pole shaft using liquid tight flexible metal conduit (Type LFMC), liquid tight flexible nonmetallic conduit (Type LFNC), high density polyethylene conduit (Type HDPE), or approved equivalent. All conductors supplying power for luminaires must run through an external disconnect prior to entrance into the structure. In accordance with the National Electrical Code (NEC) Article 230.2(E), provide identification of the electrical source provider for the luminaire feeder circuit with contact information on a permanent label located in the pole hand hole near the feeder circuit raceway.

Install a ¼-inch thick plate for a concrete foundation tag to include the following information: concrete grade, depth, diameter, and reinforcement sizes of the installed foundation. Install galvanized wire mesh to cover gap between the base plate and top of foundation for debris and pest control. Refer to standard drawing M7 for further details.

Immediately notify the Engineer of any structural deficiency that becomes apparent in any assembly, or member of any assembly, because of the design requirements imposed by these specifications, the plans, or the typical drawings.

### C. Design:

Unless otherwise specified, design all metal pole support structures using the following 1<sup>st</sup> Edition AASHTO specifications:

- Use 700-Year MRI and 10-Year MRI wind pressure maps developed from 3-second gust speeds, as provided in Section 3.8.
- Ensure metal pole support structures include natural wind gust loading and truck-induced gust loading for fatigue design, as provided in Sections 11.7.1.2 and 11.7.1.3, respectively. Designs need not consider periodic galloping forces.
- Assume 11.2 mph natural wind gust speed in North Carolina. For natural wind fatigue stress calculations, utilize a drag coefficient ( $C_d$ ) based on the yearly mean wind velocity of 11.2 mph.
- When selecting Fatigue Importance Factors, utilize Fatigue Importance Category II, as provided for in Table 11.6-1, unless otherwise specified.
- Calculate all forces using applicable equations from Section 5. The Maximum allowable force ratio for all metal pole support designs is 0.9.
- Conform to Sections 10.4.2 and 11.8 for deflection requirements. For CCTV and MVD support structures, ensure maximum deflection at top of pole does not exceed 2.0 percent of pole height.
- Assume the combined minimum weight of a messenger cable bundle (including messenger cable, signal cable and detector lead-in cables) is 1.3 lbs/ft. Assume the combined minimum diameter of the cable bundle is 1.3 inches.
- All CCTV and MVD poles shall meet the compact section limits per section 5.7.2 along with Table 5.7.2-1. Minimum thickness of CCTV and MVD pole shafts shall be ¼-inch.
- All CCTV and MVD poles shall use full-penetration groove weld tube-to-transverse plate connection with backing ring. Refer to Metal Pole Standard Drawing Sheet M9 for details. Fillet-welded tube-to-transverse-plate connections are not permitted.

Unless otherwise specified by special loading criteria, the following computed surface area for ice load on signal heads shall be used:

- 3-section, 12-inch, Surface area: 26.0 ft<sup>2</sup>
- 4-section, 12-inch, Surface area: 32.0 ft<sup>2</sup>
- 5-section, 12-inch, Surface area: 42.0 ft<sup>2</sup>

Design a base plate for each pole. The minimum base plate thickness for all poles is determined by the following criteria:

Case 1 Circular or rectangular solid base plate with the upright pole welded to the top surface of base plate with full penetration butt weld, where no stiffeners are provided. A base plate with a small center hole, which is less than 1/3 of the upright diameter, and located concentrically with the upright pole, may be considered as a solid base plate.

The magnitude of bending moment in the base plate, induced by the anchoring force of each anchor bolt is  $M = (P \times D_1) / 2$ , where

M = bending moment at the critical section of the base plate induced by one (1) anchor bolt

P = anchoring force of each anchor bolt

D<sub>1</sub> = horizontal distance between the anchor bolt center and the outer face of the upright, or the difference between the bolt circle radius and the outside radius of the upright

Locate the critical section at the face of the anchor bolt and perpendicular to the bolt circle radius. The overlapped part of two (2) adjacent critical sections is considered ineffective.

Case 2 Circular or rectangular base plate with the upright pole socketed into and attached to the base plate with two (2) lines of fillet weld, and where no stiffeners are provided, or any base plate with a center hole that is larger in diameter than 1/3 of the upright diameter.

The magnitude of bending moment induced by the anchoring force of each anchor bolt is  $M = P \times D_2$ ,

where P = anchoring force of each anchor bolt

D<sub>2</sub> = horizontal distance between the face of the upright and the face of the anchor bolt nut

Locate the critical section at the face of the anchor bolt top nut and perpendicular to the radius of the bolt circle. The overlapped part of two (2) adjacent critical sections is considered ineffective.

If the base plate thickness calculated for Case 2 is less than Case 1, use the thickness calculated for Case 1.

The following additional requirements apply concerning pole base plates.

- Ensure that whichever case governs as defined above, the anchor bolt diameter is set to match the base plate thickness. If the minimum diameter required for the anchor bolt exceeds the thickness required for the base plate, set the base plate thickness equal to the required bolt diameter.
- For all metal poles, use a full penetration groove weld with a backing ring to connect the pole upright component to the base. Refer to Metal Pole Standard Drawing Sheet M3 or M4.

The Professional Engineer is wholly responsible for the design of all poles. Review and acceptance of these designs by the Department does not relieve the said Professional Engineer of his or her responsibility.

#### D. Strain Poles:

Refer to Metal Pole Standard Drawing Sheets M2 and M3 for fabrication details.

Provide two (2) messenger cable (span wire) clamps and associated hardware for attachment of messenger cable. Ensure diameter of the clamp is appropriate to its location on the pole and is appropriately designed for adjustment from 1'-6" below the top, down to 6'-6" below the top of the pole. Do not attach more than one (1) support cable to a messenger cable clamp.

Provide a minimum of three (3) 2-inch holes equipped with an associated coupling and weatherhead on the messenger cable load side of the pole to accommodate passage of signal cables from inside the pole. Provide galvanized threaded plugs for all unused couplings at pole entrance points. Refer to Metal Pole Standard Drawing Sheet M3 for fabrication details.

Provide designs with a 6" x 12" hand hole with reinforcing frame for each pole.

Provide a terminal compartment with cover and screws in each pole encompassing the hand hole and containing a 12-terminal barrier type terminal block. Provide two (2) terminal screws with a removable shorting bar between them for each termination. Furnish terminal compartment covers attached to the pole by a sturdy chain or cable approved by the Engineer. Ensure chain or cable is long enough to permit cover to hang clear of the compartment opening when cover is removed and is strong enough to prevent vandalism. Ensure chain or cable will not interfere with service to cables in the pole base.

Have poles permanently stamped above the hand holes with the identification tag details as shown on Metal Pole Standard Drawing Sheets M2 and M3.

Provide grounding lug(s) in the approximate vicinity of the messenger cable clamp for bonding and grounding messenger cable. Lugs must accept #4 AWG wire to bond messenger cables to the pole in order to provide an effective ground fault circuit path. Refer to Metal Pole Standard Drawing Sheet M6 for construction details.

Install metal poles, hardware, and fittings as shown on the manufacturer's installation drawings. Ensure the installed pole, when fully loaded, is within 1 degree 40 minutes (1°40') of vertical. Install poles with the manufacturer's recommended "rake." Where required, use threaded leveling nuts to establish rake.

#### 5.2. DRILLED PIER FOUNDATIONS FOR METAL POLES

Analysis procedures and formulas shall be based on AASHTO 1<sup>st</sup> Edition, latest ACI-318 code and the *Drilled Shafts: Construction Procedures and Design Methods* FHWA-NHI-10-016 manual. Design methods based on engineering publications or research papers must have prior approval from NCDOT. The Department reserves the right to accept or reject any method used for the analysis.

Ensure deflection at top of foundation does not exceed 1 inch for worst-case (Service Limit State) lateral load.

Use LPILE Plus V6.0 or later for lateral analysis. Submit inputs, results and corresponding graphs with the design calculations.

Calculate skin friction using the  $\alpha$ -method for cohesive soils and the  $\beta$ -method for cohesion-less soils (**Broms method will not be accepted**). Detailed descriptions of the " $\alpha$ " and " $\beta$ " methods can be found in *FHWA-NHI-10-016*.

Omit first 2.5 feet for cohesive soils when calculating skin friction.

U-3422A

TS-40

Cumberland County

Assume a hammer efficiency of 0.70 unless value is provided.

All CCTV and MVD pole drilled shafts shall be a minimum of 4'-0" diameter. Refer to Standard Drawing Nos. M7 and M8.

Design custom foundations to carry maximum capacity of each metal pole. For standard case strain poles with custom design, use actual shear, axial and moment reactions from the Standard Strain Pole Foundation Selection Table shown on Standard Drawing No. M8.

When poor soil conditions are encountered, which could create an excessively large foundation design, consideration may be given to allow an exemption to the maximum capacity design. The Contractor must gain approval from the Engineer before reducing a foundation's capacity. On projects where poor soil is known to be present, the Contractor should have foundation designs approved before releasing poles for fabrication.

Have the Contractor notify the Engineer if the proposed foundation is to be installed on a slope other than 8H: 1V or flatter.

#### **A. Description:**

Furnish and install foundations for NCDOT metal poles with all necessary hardware in accordance with the plans and specifications.

Metal Pole Standards have been developed and implemented by NCDOT for use at signalized intersections in North Carolina. If the plans call for a standard strain pole, then a standard foundation may be selected from the plans. However, the Contractor is not required to use a standard foundation. If the Contractor chooses to design a non-standard site-specific foundation for a standard strain pole or if the plans call for a non-standard site-specific pole, design the foundation to conform to the applicable provisions in the NCDOT Metal Pole Standard Drawings and Section B4 (Non-Standard Foundation Design) below. If non-standard site-specific foundations are designed for standard QPL approved strain poles, the foundation designer must use the design moment specified by load case on Metal Pole Standard Drawing Sheet M8. Failure to conform to this requirement will be grounds for rejection of the design.

If the Contractor chooses to design a non-standard foundation for a standard strain pole and the soil test results indicate a standard foundation is feasible for the site, the Contractor will be paid the cost of the standard foundation. Any additional cost associated with a non-standard site-specific foundation including additional materials, labor and equipment will be considered incidental to the cost of the standard foundation. All costs for the non-standard foundation design will be considered incidental to the cost of the standard foundation.

#### **B. Soil Test and Foundation Determination:**

##### **1. General:**

Drilled piers are reinforced concrete sections, cast-in-place against in situ, undisturbed material. Drilled piers are of straight shaft type and vertical.

##### **2. Soil Test:**

Perform a soil test at each proposed metal pole location. Complete all required fill placement and excavation at each pole location to finished grade before drilling each boring. Soil tests performed that are not in compliance with this requirement may be rejected and will not be paid. Drill one boring to a depth of 26 feet within a 25-foot radius of each proposed foundation.

Perform standard penetration tests (SPT) in accordance with ASTM D 1586 at depths of 1, 2.5, 5, 7.5, 10, 15, 20 and 26 feet. Discontinue the boring if one of the following occurs:

- A total of 100 blows have been applied in any two consecutive 6-inch intervals.



- A total of 50 blows have been applied with < 3-inch penetration.

Describe each pole location along the project corridor in a manner that is easily discernible to both the Contractor’s Designer and NCDOT Reviewers. If the pole is at an intersection, label the boring the “Intersection of (Route or SR #), (Street Name) and (Route or SR #), (Street Name), \_\_\_\_\_ County, Signal or Asset Inventory No. \_\_\_\_\_”. Label borings with “B- N, S, E, W, NE, NW, SE or SW” corresponding to the quadrant location within the intersection.

If the pole location is located between intersections, provide a coordinate location and offset, or milepost number and offset. Pole numbers should be made available to the Drill Contractor. Include pole numbers in the boring label if they are available. If they are not available, ensure the boring labels can be cross-referenced to corresponding pole numbers. For each boring, submit a legible (hand-written or typed) boring log signed and sealed by a licensed Geologist or Professional Engineer registered in North Carolina. Include on each boring the SPT blow counts and N-values at each depth, depth of the boring, hammer efficiency, depth of water table and a general description of the soil types encountered using the AASHTO Classification System.

Borings that cannot be easily correlated to their specific pole location will be returned to the Contractor for clarification; or if approved by the Engineer, the foundation may be designed using the worst-case soil condition obtained as part of this project.

**3. Standard Foundation Determination:**

Use the following method for determining the Design N-value:

$$N_{AVG} = \frac{N_{@1'} + N_{@2.5'} + \dots + N_{@Deepest\ Boring\ Depth}}{Total\ Number\ of\ N\ values}$$

$$Y = (N_{@1'})^2 + (N_{@2.5'})^2 + \dots + (N_{@Deepest\ Boring\ Depth})^2$$

$$Z = N_{@1'} + N_{@2.5'} + \dots + N_{@Deepest\ Boring\ Depth}$$

$$N_{STD\ DEV} = \sqrt{\left( \frac{(Total\ Number\ of\ N\ values \times Y) - Z^2}{(Total\ Number\ of\ N\ values) \times (Total\ Number\ of\ N\ values - 1)} \right)}$$

**Design N-value** equals lesser of the following two conditions:

$$N_{AVG} - (N_{STD\ DEV} \times 0.45)$$

**OR**

$$Average\ of\ First\ Four\ (4)N\ values = \frac{N_{@1'} + N_{@2.5'} + N_{@5'} + N_{@7.5'}}{4}$$

*Note: If less than four (4) N-values are obtained because of criteria listed in Section 2 above, use average of N-values collected for second condition. Do not include the N-value at the deepest boring depth for above calculations if the boring is discontinued at or before the required boring depth because of criteria listed in Section 2 above. Use N-value of zero (0) for weight of hammer or weight of rod. If N-value is greater than fifty (50), reduce N-value to fifty (50) for calculations.*

If standard NCDOT strain poles are shown on the plans and the Contractor chooses to use standard foundations, determine a drilled pier length, “L,” for each signal pole from the Standard Strain Pole Foundations Chart (sheet M8) based on the Design N-value and the predominant soil type. For each standard pole location, submit a completed “Metal Pole Standard Foundation Selection Form” signed by the Contractor’s representative. Signature on form is for verification purposes only. Include the Design N-value calculation and resulting drilled pier length, “L,” on each form.

If non-standard site-specific poles are shown on the plans, submit completed boring logs collected in accordance with Section 2 (Soil Test) along with pole loading diagrams from the plans to the Contractor-selected pole Fabricator to assist in the pole and foundation design.

If one of the following occurs, the Standard Foundations Chart shown on the plans may not be used and a non-standard foundation may be required. In such case, contact the Engineer.

- The Design N-value is less than four (4).
- The drilled pier length, “L”, determined from the Standard Foundations Chart, is greater than the depth of the corresponding boring.

In the case where a standard foundation cannot be used, the Department will be responsible for the additional cost of the non-standard foundation.

Foundation designs are based on level ground around the traffic signal pole. If the slope around the edge of the drilled pier is steeper than 8:1 (H:V) or the proposed foundation will be less than 10 feet from the top of an embankment slope, the Contractor is responsible for providing slope information to the foundation Designer and to the Engineer so it can be considered in the design.

The “Metal Pole Standard Foundation Selection Form” may be found at:

<https://connect.ncdot.gov/resources/safety/Pages/ITS-Design-Resources.aspx>

If assistance is needed, contact the Engineer.

#### **4. Non-Standard Foundation Design:**

Design non-standard foundations based upon site-specific soil test information collected in accordance with Section 2 (Soil Test). Design drilled piers for side resistance in accordance with Section 10.8 of the *2014 AASHTO LRFD Bridge Design Specifications, 7<sup>th</sup> Edition*. Use computer software LPILE version-6.0 or later manufactured by Ensoft, Inc. to analyze drilled piers. Use computer software gINT V8i or later manufactured by Bentley Systems, Inc. with the current NCDOT gINT library and data template to produce SPT boring logs. Provide a drilled pier foundation for each pole with a length and diameter resulting in horizontal lateral movement less than 1 inch at top of the pier, and horizontal rotational movement less than 1 inch at the edge of pier. Contact the Engineer for pole loading diagrams of standard poles used for non-standard foundation designs. Submit non-standard foundation designs including drawings, calculations, and soil boring logs to the Engineer for review and approval before construction.

#### **C. Drilled Pier Construction:**

Construct drilled pier foundation and Install anchor rod assemblies in accordance with the *Foundations and Anchor Rod Assemblies for Metal Poles* Standard Special Provision SP09-R005 located at:

<https://connect.ncdot.gov/resources/Specifications/Pages/2024-Specifications-and-Special-Provisions.aspx>

**5.3. POLE NUMBERING SYSTEM**

**A. New Poles**

Attach an identification tag to each pole shaft section as shown on Metal Pole Standard Sheet M2 “Typical Fabrication Details for All Metal Poles.”

**5.4. MEASUREMENT AND PAYMENT**

Actual number of metal strain signal poles (without regard to height or load capacity) furnished, installed and accepted.

Actual number of soil tests with SPT borings drilled furnished and accepted.

Actual volume of concrete poured in cubic yards of drilled pier foundation furnished, installed and accepted.

No measurement will be made for foundation designs prepared with metal pole designs, as these will be considered incidental to designing Traffic Signal , CCTV or MVD support structures.

**Payment will be made under:**

Metal Strain Signal Pole .....	Each
Soil Test .....	Each
Drilled Pier Foundation.....	Cubic Yard

**6. ETHERNET EDGE SWITCH**

Furnish and install a managed Ethernet edge switch as specified below that is fully compatible, interoperable, and completely interchangeable and functional within the existing City, Division, or Statewide traffic signal system communications network.

**6.1.DESCRPTION**

**A. Ethernet Edge Switch:**

Furnish and install a hardened, field Ethernet edge switch (hereafter “edge switch”) for the traffic signal controller or ITS device as specified below. Ensure that the edge switch provides wire-speed, fast Ethernet connectivity at transmission rates of 1000 megabits per second from each remote traffic signal controller or ITS device location to the routing switches.

Contact the City or NCDIT to arrange for the programming of the new Field Ethernet Switches with the necessary network configuration data, including but not limited to, the IP Address, Default Gateway, Subnet Mask and VLAN ID information. Provide a minimum ten (10) working days notice to allow the City or NCDIT to program the new devices.

**B. Network Management:**

Ensure that the edge switch is fully compatible with the existing City, Division, or Statewide Network Management Software.

**6.2.MATERIALS**

**A. General:**

Ensure that the edge switch is fully compatible and interoperable with the trunk Ethernet network interface and that the edge switch supports half and full duplex Ethernet communications.

U-3422A

TS-44

Cumberland County

Furnish an edge switch that provide 99.999% error-free operation, and that complies with the Electronic Industries Alliance (EIA) Ethernet data communication requirements using single-mode fiber-optic transmission medium and copper transmission medium. Ensure that the edge switch has a minimum mean time between failures (MTBF) of 10 years, or 87,600 hours, as calculated using the Bellcore/Telcordia SR-332 standard for reliability prediction.

### **B. Compatibility Acceptance**

The Engineer has the authority to require the Contractor to submit a sample Field Ethernet Switch and SFP along with all supporting documentation, software and testing procedures to allow a compatibility acceptance test be performed prior to approving the proposed Field Ethernet Switch and Field Ethernet Transceiver for deployment. **The Compatibility Acceptance testing will ensure that the proposed device is 100% compatible and interoperable with the existing City, Division, or Statewide Signal System network, monitoring software and Traffic Operations Center network hardware.** Allow fifteen (15) working days for the Compatibility Acceptance Testing to be performed

### **C. Standards:**

Ensure that the edge switch complies with all applicable IEEE networking standards for Ethernet communications, including but not limited to:

- IEEE 802.1D standard for media access control (MAC) bridges used with the Spanning Tree Protocol (STP);
- IEEE 802.1Q standard for port-based virtual local area networks (VLANs);
- IEEE 802.1P standard for Quality of Service (QoS);
- IEEE 802.1w standard for MAC bridges used with the Rapid Spanning Tree Protocol (RSTP);
- IEEE 802.1s standard for MAC bridges used with the Multiple Spanning Tree Protocol;
- IEEE 802.1x standard for port based network access control, including RADIUS;
- IEEE 802.3 standard for local area network (LAN) and metropolitan area network (MAN) access and physical layer specifications;
- IEEE 802.3u supplement standard regarding 100 Base TX/100 Base FX;
- IEEE 802.3x standard regarding flow control with full duplex operation; and
- IFC 2236 regarding IGMP v2 compliance.
- IEEE 802.1AB Link Layer Discovery Protocol (LLDP)
- IEEE 802.3ad Ethernet Link Aggregation
- IEEE 802.3i for 10BASE-T (10 Mbit/s over Fiber-Optic)
- IEEE 802.3ab for 1000BASE-T (1Gbit/s over Ethernet)
- IEEE 802.3z for 1000BASE-X (1 Gbit/s Ethernet over Fiber-Optic)

### **D. Functional:**

Ensure that the edge switch supports all Layer 2 management features and certain Layer 3 features related to multicast data transmission and routing. These features shall include, but not be limited to:

- An STP healing/convergence rate that meets or exceeds specifications published in the IEEE 802.1D standard.
- An RSTP healing/convergence rate that meets or exceeds specifications published in the IEEE 802.1w standard.

- An Ethernet edge switch that is a port-based VLAN and supports VLAN tagging that meets or exceeds specifications as published in the IEEE 802.1Q standard, and has a minimum 4-kilobit VLAN address table (254 simultaneous).
- A forwarding/filtering rate that is a minimum of 14,880 packets per second for 10 megabits per second and 148,800 packets per second for 100 megabits per second.
- A minimum 4-kilobit MAC address table.
- Support of Traffic Class Expediting and Dynamic Multicast Filtering.
- Support of, at a minimum, snooping of Version 2 & 3 of the Internet Group Management Protocol (IGMP).
- Support of remote and local setup and management via telnet or secure Web-based GUI and command line interfaces.
- Support of the Simple Network Management Protocol version 3 (SNMPv3). Verify that the Ethernet edge switch can be accessed using the resident EIA-232 management port, a telecommunication network, or the Trivial File Transfer Protocol (TFTP).
- Port security through controlling access by the users. Ensure that the Ethernet edge switch has the capability to generate an alarm and shut down ports when an unauthorized user accesses the network.
- Support of remote monitoring (RMON-1 & RMON-2) of the Ethernet agent.
- Support of the TFTP and SNTP. Ensure that the Ethernet edge switch supports port mirroring for troubleshooting purposes when combined with a network analyzer.

#### **E. Physical Features:**

*Ports:* Provide 10/100/1000 Mbps auto-negotiating ports (RJ-45) copper Fast Ethernet ports for all edge switches. Provide auto-negotiation circuitry that will automatically negotiate the highest possible data rate and duplex operation possible with attached devices supporting the IEEE 802.3 Clause 28 auto-negotiation standard.

*Optical Ports:* Ensure that all fiber-optic link ports operate at 1310 or 1550 nanometers in single mode. Provide Type LC connectors for the optical ports, as specified in the Plans or by the Engineer. Do not use mechanical transfer registered jack (MTRJ) type connectors.

Provide an edge switch having a minimum of two optical 100/1000 Base X ports capable of transmitting data at 100/1000 megabits per second. Ensure that each optical port consists of a pair of fibers; one fiber will transmit (TX) data and one fiber will receive (RX) data. Ensure that the optical ports have an optical power budget of at least 15 dB. Provide small form-factor pluggable modules (SFPs) with a maximum range that meets or exceeds the distance requirement as indicated on the Plans.

*Copper Ports:* Provide an edge switch that includes a minimum of four copper ports. Provide Type RJ-45 copper ports and that auto-negotiate speed (i.e., 10/100/1000 Base) and duplex (i.e., full or half). Ensure that all 10/100/1000 Base TX ports meet the specifications detailed in this section and are compliant with the IEEE 802.3 standard pinouts. Ensure that all Category 6 unshielded twisted pair/shielded twisted pair network cables are compliant with the EIA/TIA-568-B standard.

*Port Security:* Ensure that the edge switch supports/complies with the following (remotely) minimum requirements:

- Ability to configure static MAC addresses access;

- Ability to disable automatic address learning per ports; know hereafter as Secure Port. Secure Ports only forward; and
- Trap and alarm upon any unauthorized MAC address and shutdown for programmable duration. Port shutdown requires administrator to manually reset the port before communications are allowed.

#### **F. Management Capabilities:**

Ensure that the edge switch supports all Layer 2 management features and certain Layer 3 features related to multicast data transmission and routing. These features shall include, but not be limited to:

- An STP healing/convergence rate that meets or exceeds specifications published in the IEEE 802.1 D standards;
- An RSTP healing/convergence rate that meets or exceeds specifications published in the IEEE 802.1w standard;
- An Ethernet edge switch that is a port-based VLAN and supports VLAN tagging that meets or exceeds specifications as published in the IEEE 802.1Q standard, and has a minimum 4-kilobit VLAN address table (254 simultaneous);
- A forwarding/filtering rate that is a minimum of 14,880 packets per second for 10 megabits per second, 148,800 packets per second for 100 megabits per second and 1,488,000 packets per second for 1000 megabits per second;
- A minimum 4-kilobit MAC address table;
- Support of Traffic Class Expediting and Dynamic Multicast Filtering.
- Support of, at a minimum, snooping of Version 2 & 3 of the Internet Group Management Protocol (IGMP);
- Support of remote and local setup and management via telnet or secure Web-based GUI and command line interfaces; and
- Support of the Simple Network Management Protocol (SNMP). Verify that the Ethernet edge switch can be accessed using the resident EIA-232 management port, a telecommunication network, or the Trivial File Transfer Protocol (TFTP).

*Network Capabilities:* Provide an edge switch that supports/complies with the following minimum requirements:

- Provide full implementation of IGMPv2 snooping (RFC 2236);
- Provide full implementation of SNMPv1, SNMPv2c, and/or SNMPv3;
- Provide support for the following RMON–I groups, at a minimum:
  - Part 1: Statistics
  - Part 2: History
  - Part 3: Alarm
  - Part 9: Event
- Provide support for the following RMON–2 groups, at a minimum:
  - Part 13: Address Map
  - Part 16: Layer Host
  - Part 17: Layer Matrix
  - Part 18: User History
- Capable of mirroring any port to any other port within the switch;
- Meet the IEEE 802.1Q (VLAN) standard per port for up to four VLANs;
- Meet the IEEE 802.3ad (Port Trunking) standard for a minimum of two groups of four ports;
- Password manageable;

- Telnet/CLI;
- HTTP (Embedded Web Server) with Secure Sockets Layer (SSL); and
- Full implementation of RFC 783 (TFTP) to allow remote firmware upgrades.

*Network Security:* Provide an edge switch that supports/complies with the following (remotely) minimum network security requirements:

- Multi-level user passwords;
- RADIUS centralized password management (IEEE 802.1X);
- SNMPv3 encrypted authentication and access security;
- Port security through controlling access by the users: ensure that the Ethernet edge switch has the capability to generate an alarm and shut down ports when an unauthorized user accesses the network;
- Support of remote monitoring (RMON-1&2) of the Ethernet agent; and
- Support of the TFTP and SNTP. Ensure that the Ethernet edge switch supports port mirroring for troubleshooting purposes when combined with a network analyzer.

### **G. Electrical Specifications:**

Ensure that the edge switch operates and power is supplied with 115 volts of alternating current (VAC). Ensure that the edge switch has a minimum operating input of 110 VAC and a maximum operating input of 130 VAC. Ensure that if the device requires operating voltages other than 120 VAC, supply the required voltage converter. Ensure that the maximum power consumption does not exceed 50 watts. Ensure that the edge switch has diagnostic light emitting diodes (LEDs), including link, TX, RX, speed (for Category 6 ports only), and power LEDs.

### **H. Environmental Specifications:**

Ensure that the edge switch performs all of the required functions during and after being subjected to an ambient operating temperature range of -30 degrees to 165 degrees Fahrenheit as defined in the environmental requirements section of the NEMA TS 2 standard, with a noncondensing humidity of 0 to 95%.

Provide certification that the device has successfully completed environmental testing as defined in the environmental requirements section of the NEMA TS 2 standard. Provide certification that the device meets the vibration and shock resistance requirements of Sections 2.1.9 and 2.1.10, respectively, of the NEMA TS 2 standard. Ensure that the edge switch is protected from rain, dust, corrosive elements, and typical conditions found in a roadside environment.

The edge switch shall meet or exceed the following environmental standards:

- IEEE 1613 (electric utility substations)
- IEC 61850-3 (electric utility substations)
- IEEE 61800-3 (variable speed drive systems)
- IEC 61000-6-2 (generic industrial)
- EMF – FCC Part 15 CISPR (EN5502) Class A

### **I. Ethernet Patch Cable:**

Furnish a factory pre-terminated/pre-connectorized Ethernet patch cable with each edge switch. Furnish Ethernet patch cables meeting the following physical requirements:

- Five (5)-foot length

- Category 6 or better
- Factory-installed RJ-45 connectors on both ends
- Molded anti-snag hoods over connectors
- Gold plated connectors
- Copper-clad aluminum is **NOT** allowed.

Furnish Fast Ethernet patch cords meeting the following minimum performance requirements:

- TIA/EIA-568-B-5, Additional Transmission Performance Specifications for 4-pair 100 Ω Enhanced Category 6 Cabling
- Frequency Range: 1-100 MHz
- Near-End Crosstalk (NEXT): 30.1 dB
- Power-sum NEXT: 27.1 dB
- Attenuation to Crosstalk Ratio (ACR): 6.1 dB
- Power-sum ACR: 3.1 dB
- Return Loss: 10dB
- Propagation Delay: 548 nsec

**6.3.CONSTRUCTION METHODS**

**A. General:**

Ensure that the edge switch is UL listed.

Verify that network/field/data patch cords meet all ANSI/EIA/TIA requirements for Category 6 four-pair unshielded twisted pair cabling with stranded conductors and RJ45 connectors.

Contact the City, Division, or NCDIT a minimum of 10 working days prior to installation to allow for the programming of the edge switch.

**B. Edge Switch:**

Mount the edge switch inside each field cabinet by securely fastening the edge switch to the upper end of the right rear vertical rail of the equipment rack using manufacturer-recommended or Engineer-approved attachment methods, attachment hardware and fasteners.

Ensure that the edge switch is mounted securely in the cabinet and is fully accessible by field technicians without blocking access to other equipment. Verify that fiber-optic jumpers consist of a length of cable that has connectors on both ends, primarily used for interconnecting termination or patching facilities and/or equipment.

**6.4.MEASURMENT AND PAYMENT**

*Ethernet edge switch* will be measured and paid as the actual number of Ethernet edge switches furnished, installed, and accepted.

No separate measurement will be made for Ethernet patch cable, small form factor pluggable modules (SFPs), power cord, mounting hardware, nuts, bolts, brackets, or edge switch programming as these will be considered incidental to furnishing and installing the edge switch.

Payment will be made under:

Ethernet Edge Switch.....Each



**PROJECT SPECIAL PROVISION**

(10-18-95) (Rev. 10-15-24)

Z-1

**PERMITS**

The Contractor's attention is directed to the following permits, which have been issued to the Department of Transportation by the authority granting the permit.

<b><u>PERMIT</u></b>	<b><u>AUTHORITY GRANTING THE PERMIT</u></b>
Dredge and Fill and/or Work in Navigable Waters (404)	U. S. Army Corps of Engineers
Water Quality (401)	Division of Water Resources, DEQ State of North Carolina

The Contractor shall comply with all applicable permit conditions during construction of this project.

Agents of the permitting authority will periodically inspect the project for adherence to the permits.

The Contractor's attention is also directed to Articles 107-10 and 107-13 of the *Standard Specifications* and the following:

Should the Contractor propose to utilize construction methods (such as temporary structures or fill in waters and/or wetlands for haul roads, work platforms, cofferdams, etc.) not specifically identified in the permit (individual, general, or nationwide) authorizing the project it shall be the Contractor's responsibility to coordinate with the Engineer to determine what, if any, additional permit action is required. The Contractor shall also be responsible for initiating the request for the authorization of such construction method by the permitting agency. The request shall be submitted through the Engineer. The Contractor shall not utilize the construction method until it is approved by the permitting agency. The request normally takes approximately 60 days to process; however, no extensions of time or additional compensation will be granted for delays resulting from the Contractor's request for approval of construction methods not specifically identified in the permit.

**Where construction moratoriums are contained in a permit condition which restricts the Contractor's activities to certain times of the year, those moratoriums will apply only to the portions of the work taking place in the restricted waters, wetlands or buffer zones, provided that activities outside those areas is done in such a manner as to not affect the restricted waters, wetlands or buffer zones.**



STATE OF NORTH CAROLINA  
DEPARTMENT OF TRANSPORTATION

ROY COOPER  
GOVERNOR

J. ERIC BOYETTE  
SECRETARY

September 27, 2023

MEMORANDUM TO: Division Environmental and Construction Units

FROM: Gregory W. Price, SPWS  
Division 6 Environmental Program Supervisor

SUBJECT: Environmental Permits for the Improvements to SR 1003 from  
Future I-295 to NC 59, Cumberland County  
**STIP U-3422, WBS 39001.1.1**

Please find enclosed the following permit for this project:

Agency	Permit Type	Permit Expiration
US Army Corps of Engineers Section 404 Clean Water Act Permit	General Permit 50	May 25, 2025
NC Division of Water Resources Section 401 Water Quality Certification	GC No. 4135	May 25, 2025

Work is authorized by the above referenced permit provided it is accomplished in strict accordance with the permitted plans.

The Division Environmental Office must be consulted if any deviation from the permit(s) is required.

The General Conditions and Certifications for Nationwide and Regional Permits can be referenced at:

<https://www.deq.nc.gov/about/divisions/water-resources/water-quality-permitting/401-buffer-permitting/general-certifications>

Mailing Address:  
NC DEPARTMENT OF TRANSPORTATION  
DIVISION 6 ENVIRONMENTAL OFFICE  
558 GILLESPIE STREET  
FAYETTEVILLE, NC 28302

Telephone: (910) 364-0683  
Fax: (910) 486-1959  
Customer Service: 1-877-368-4968

Website: [www.ncdot.gov](http://www.ncdot.gov)

Location:  
431 TRANSPORTATION DRIVE  
FAYETTEVILLE, NC 28302

**U.S. ARMY CORPS OF ENGINEERS  
WILMINGTON DISTRICT**

Action Id. **SAW-2017-00775**

County: **Cumberland County**

U.S.G.S. Quad: **Parkton**

**GENERAL PERMIT (REGIONAL AND NATIONWIDE) VERIFICATION**

Permittee: **Gregory Price**  
**NC DOT Division 6**  
Address: **PO Box 1150**  
**Fayetteville NC, 28302**  
Telephone Number: **910.364.0683**

Size (acres) **N/A** Nearest Town **Hope Mills**  
Nearest Waterway **Little Rockfish Creek** River Basin **Cape Fear**  
USGS HUC **03030004** Coordinates Latitude: **34.977**; Longitude: **-78.9899**  
Location description: **SR 1003 (Camden Road) corridor, from NC 59 (Hope Mills road) to the future location of the permitted Fayetteville Outer Loop, west of Hope Mills, NC.**

Description of projects area and activity: **TIP U-3422; Road widening and improvements impacting 0.51 acre of wetlands (0.45 acre permanent fill and excavation; 0.06 acre mechanized clearing), 429 linear feet (lf), 0.13 acre, of tributaries (408 lf, 0.064 acre, permanent channel impact; 21 linear feet, 0.002 acre, temporary impacts), and 0.09 acre impact to open-water pond (0.05 acre permanent; 0.04 acre temporary).**

Applicable Law:  Section 404 (Clean Water Act, 33 USC 1344);  
 Section 10 (Rivers and Harbors Act, 33 USC 403)

Authorization: Regional General Permit Number: **GP 50 - NCDOT - Bridge, Road Widening and Interchanges**

***SEE ATTACHED RGP GENERAL AND SPECIAL CONDITIONS***

**Your work is authorized by the above referenced permit provided it is accomplished in strict accordance with the attached conditions and your submitted application and attached information dated July 11, 2023. Any violation of the attached conditions or deviation from your submitted plans may subject the permittee to a stop work order, a restoration order, a Class I administrative penalty, and/or appropriate legal action.**

This verification will remain valid until the expiration date identified below unless the nationwide and/or regional general permit authorization is modified, suspended or revoked. If, prior to the expiration date identified below, the nationwide and/or regional general permit authorization is reissued and/or modified, this verification will remain valid until the expiration date identified below, provided it complies with all requirements of the modified nationwide permit. If the nationwide and/or regional general permit authorization expires or is suspended, revoked, or is modified, such that the activity would no longer comply with the terms and conditions of the nationwide permit, activities which have commenced (i.e., are under construction) or are under contract to commence in reliance upon the nationwide and/or regional general permit, will remain authorized provided the activity is completed within twelve months of the date of the nationwide and/or regional general permit's expiration, modification or revocation, unless discretionary authority has been exercised on a case-by-case basis to modify, suspend or revoke the authorization.

SAW-2017-00775

This Department of the Army verification does not relieve the permittee of the responsibility to obtain any other required Federal, State or local approvals/permits.

If there are any questions regarding this verification, any of the conditions of the Permit, or the Corps of Engineers regulatory program, please contact **Eric Alsmeyer at (919) 817-1570 or Eric.C.Alsmeier@usace.army.mil.**

Corps Regulatory Official: Jean B. Gibby Date: **September 22, 2023**  
Expiration Date of Verification: **May 25, 2025**

The Wilmington District is committed to providing the highest level of support to the public. To help us ensure we continue to do so, please complete our Customer Satisfaction Survey, located online at <https://regulatory.ops.usace.army.mil/customer-service-survey/>

Copy furnished (by email): B. Harmon, NCDMS; beth.harmon@deq.nc.gov.

SAW-2017-00775

**SPECIAL CONDITIONS**

1. **Compensatory Mitigation:** In order to compensate for impacts associated with this permit, mitigation shall be provided in accordance with the provisions outlined on the most recent version of the attached Compensatory Mitigation Responsibility transfer form. The requirements of this form, including any special conditions listed on this form, are hereby incorporated as special conditions of this permit authorization.
  
2. **Tri-colored bat** - No tree clearing will occur within 150 feet of a known maternity roost tree May 1 - July 31 in order to protect non-volant young. Winter roost trees are not considered maternity roost trees. NCDOT will cross-reference information given by USFWS on the locations of maternity roosts (as they are discovered) to stay in compliance with this condition.
  
3. **NLEB** - The Wilmington District, Federal Highway Administration, U.S. Fish and Wildlife Service (USFWS), and the North Carolina Department of Transportation (NCDOT) have conducted programmatic Section 7(a)(2) consultation for the Northern long-eared bat (NLEB) for NCDOT projects located in Divisions 1-8. The result of this programmatic consultation is a Programmatic Biological Opinion (PBO) issued by the USFWS titled, "Programmatic Biological Opinion – Revised, NCDOT Program Effects on the Northern Long-eared Bat in Divisions 1-8", dated December 15, 2022. This PBO contains agreed upon conservation measures which would minimize take of NLEB. As noted in the PBO, applicability of these conservation measures varies depending on the location of the project. The USFWS has documented that no reasonable and prudent measures, nor terms and conditions, are necessary or appropriate to minimize the amount or extent of incidental take of NLEB caused by the Action; therefore, the incidental take statement does not provide reasonable and prudent measures for this species. Department of the Army (DA) authorization under general permit or standard permit (Individual Permit) is conditional upon the permittee's compliance with applicable, agreed upon conservation measures of the PBO, which is incorporated by reference in this verification letter. Failure to comply with the applicable conservation measures, where a take of the NLEB occurs, would constitute an unauthorized take by the permittee, and would also constitute permittee non-compliance with this verification letter. The USFWS is the appropriate authority to determine compliance with the terms and conditions of its PBO and the ESA. All PBOs can be found on our website at: <https://www.saw.usace.army.mil/Missions/Regulatory-Permit-Program/Agency-Coordination/ESA/>.

# P-6

Action ID Number: SAW-2017-00775

County: Cumberland County

Permittee: Gregory Price  
NC DOT Division 6

Project Name: NCDOT U-3422 SR1003 CamdenRdWiden Cumberland Div6

Date Verification Issued: September 20, 2023

Project Manager: Eric Alsmeyer

Upon completion of the activity authorized by this permit and any mitigation required by the permit, sign this certification and return it to the following address:

US ARMY CORPS OF ENGINEERS  
WILMINGTON DISTRICT  
Attn: Eric Alsmeyer  
Raleigh Regulatory Field Office  
3331 Heritage Trade Drive, Suite 105  
Wake Forest, NC 27587  
919.554.4884, Ext. 23

Please note that your permitted activity is subject to a compliance inspection by a U. S. Army Corps of Engineers representative. Failure to comply with any terms or conditions of this authorization may result in the Corps suspending, modifying or revoking the authorization and/or issuing a Class I administrative penalty, or initiating other appropriate legal action.

I hereby certify that the work authorized by the above referenced permit has been completed in accordance with the terms and condition of the said permit, and required mitigation was completed in accordance with the permit conditions.

\_\_\_\_\_  
Signature of Permittee

\_\_\_\_\_  
Date

ROY COOPER  
Governor

ELIZABETH S. BISER  
Secretary

RICHARD E. ROGERS, JR.  
Director



July 28, 2023

DWR # 20230977  
TIP U-3422  
Cumberland County

Gregory W. Price  
Environmental Program Supervisor  
North Carolina Department of Transportation  
431 Transportation Drive  
Fayetteville, NC 28302

**Subject: APPROVAL OF 401 WATER QUALITY CERTIFICATION WITH ADDITIONAL CONDITONS**  
NCDOT U-3422, Widen and Improve SR 1003 (Camden Road) in Cumberland County.  
**Little Rockfish Creek [Cape Fear River Basin, 18-31-24-(4), C]**

Dear Mr. Price:

You have our approval for the impacts listed below for the purpose of widening and improving SR 1003 (Camden Road) in Cumberland County as described in your application dated received by the Division of Water Resources on July 11, 2023. These impacts are covered by the attached Water Quality General Certification Number 4135 and the conditions listed below. This certification is associated with the use of the Reginal General Permit 201902350 once it is issued to you by the U.S. Army Corps of Engineers. Please note that you should get any other federal, state or local permits before proceeding with your project, including those required by (but not limited to) Sediment and Erosion Control, Non-Discharge, and Water Supply Watershed regulations.

The Division has determined that the proposed project will comply with water quality requirements provided that you adhere to the conditions listed in the enclosed certification and to the additional conditions itemized below.

The following proposed impacts are hereby approved. No other impacts are approved, including incidental impacts. [15A NCAC 02H .0506(b)]



### Wetland Impacts in the Cape Fear River Basin

Site	Fill (ac)	Fill (temporary) (ac)	Excavation (ac)	Mechanized Clearing (ac)	Hand Clearing (ac)	Total Impacts (ac)
Site 1	0.260	---	---	0.060	---	0.320
Site	0.050	---	0.140	---	---	0.190
<b>Totals</b>	0.310	---	0.140	0.060	---	0.510

**Total Wetland Impact for Project: 0.510 acres**  
(permanent impacts: 0.510 ac)

### Stream Impacts in the Cape Fear River Basin

Site	Permanent Fill in Intermittent Stream (linear ft)	Temporary Fill in Intermittent Stream (linear ft)	Permanent Fill in Perennial Stream (linear ft)	Temporary Fill in Perennial Stream (linear ft)	Total Stream Impact (linear ft)	Stream Impacts Requiring Mitigation (linear ft)
1	54	12	---	---	66	N/A
4	254	---	100	9	363	N/A
<b>Total</b>	<b>308</b>	<b>12</b>	<b>100</b>	<b>9</b>	<b>429</b>	N/A

**Total Stream Impacts for Project: 429 linear feet**  
(Permanent Intermittent: 308 lf, Permanent Perennial: 100 lf)

### Open Water Impacts in the Cape Fear River Basin

Site	Permanent Fill in Open Waters (ac)	Temporary Fill in Open Waters (ac)	Total (ac)
Site 2	0.050	0.040	0.090
<b>Total</b>	<b>0.050</b>	<b>0.040</b>	<b>0.090</b>

**Total Open Water Impacts for Project: 0.090 acres**  
(permanent impacts: 0.050 ac)

This approval is for the purpose and design described in your application. The plans and specifications for this project are incorporated by reference as part of this Certification. If you change your project, you must notify the Division and you may be required to submit a new application package with the appropriate fee. If the property is sold, the new owner must be given a copy of this Certification and is responsible for complying with all conditions. [15A NCAC 02H .0507(d)(2)]. If total wetland fills for this project (now or in the future) exceed 1/10<sup>th</sup> acre, or total impacts to streams (now or in the future) exceed 300 linear feet, compensatory mitigation may be required as described in 15A NCAC 2H .0506 (h) (6) and (7).

If you are unable to comply with any of the conditions of the attached Water Quality General Certification or with the additional conditions itemized below, you must notify the DWR Transportation Permitting Branch within 24 hours (or the next business day if a weekend or holiday) from the time the permittee becomes aware of the circumstances.

The permittee shall report to the Wilmington Regional Office any noncompliance with, and/or any violation of, stream or wetland standards [15A NCAC 02B .0200] including but not limited to sediment impacts to streams or wetlands. Information shall be provided orally within 24 hours (or the next





business day if a weekend or holiday) from the time the permittee became aware of the non-compliance circumstances.

## **Additional Conditions:**

1. The issuance of this certification does not exempt the Permittee from complying with any and all statutes, rules, regulations, or ordinances that may be imposed by other government agencies (i.e. local, state, and federal) having jurisdiction, including but not limited to applicable buffer rules, stormwater management rules, soil erosion and sedimentation control requirements, etc.
2. The Permittee shall ensure that the final design drawings adhere to the permit and to the permit drawings submitted for approval. [15A NCAC 02H .0507(c) and 15A NCAC 02H .0506 (b)(2) and (c)(2)]
3. Compensatory mitigation for impacts to 0.510 acres of wetlands is required. We understand that you have chosen to perform compensatory mitigation for impacts to wetlands through the North Carolina Division of Mitigation Services (DMS) (formerly NCEEP), and that the DMS has agreed to implement the mitigation for the project. DMS has indicated in a letter dated July 10, 2023 that they will assume responsibility for satisfying the federal Clean Water Act compensatory mitigation requirements for the above-referenced project, in accordance with DMS's Mitigation Banking Instrument signed July 28, 2010.
4. The outside buffer, wetland or water boundary located within the construction corridor approved by this authorization, including all non-commercial borrow and waste sites associated with the project, shall be clearly marked by highly visible fencing prior to any land disturbing activities. Impacts to areas within the fencing are prohibited unless otherwise authorized by this certification. [15A NCAC 02H.0501 and .0502]
5. During the construction of the project, no staging of equipment of any kind is permitted in waters of the U.S., or protected riparian buffers. [15A NCAC 02H.0506(b)(2)]
6. If concrete is used during construction, a dry work area shall be maintained to prevent direct contact between curing concrete and stream water. Water that inadvertently contacts uncured concrete shall not be discharged to surface waters due to the potential for elevated pH and possible aquatic life and fish kills. [15A NCAC 02B.0200]
7. No rock, sand or other materials shall be dredged from the stream channel except where authorized by this certification. [15A NCAC 02H.0506(b)(3)]
8. The dimension, pattern and profile of the stream above and below the crossing shall not be modified. Disturbed floodplains and streams shall be restored to natural geomorphic conditions. [15A NCAC 02H.0506(b)(2)]
9. All mechanized equipment operated near surface waters must be regularly inspected and maintained to prevent contamination of stream waters from fuels, lubricants, hydraulic fluids, or other toxic materials. [15A NCAC 02H.0506(b)(3)]
10. All fill slopes located in jurisdictional wetlands shall be placed at slopes no flatter than 3:1, unless otherwise authorized by this certification. [15A NCAC 02H.0506(b)(2)]



11. When applicable, all construction activities shall be performed and maintained in full compliance with G.S. Chapter 113A Article 4 (Sediment and Pollution Control Act of 1973). Regardless of applicability of the Sediment and Pollution Control Act, all projects shall incorporate appropriate Best Management Practices for the control of sediment and erosion so that no violations of state water quality standards, statutes, or rules occur. [15A NCAC 02H .0506(b)(3) and (c)(3) and 15A NCAC 02B .0200]
  - a. Design, installation, operation, and maintenance of all sediment and erosion control measures shall be equal to or exceed the requirements specified in the most recent version of the *North Carolina Sediment and Erosion Control Manual*, or for linear transportation projects, the *NCDOT Sediment and Erosion Control Manual*.
  - b. All devices shall be maintained on all construction sites, borrow sites, and waste pile (spoil) sites, including contractor-owned or leased borrow pits associated with the project. Sufficient materials required for stabilization and/or repair of erosion control measures and stormwater routing and treatment shall be on site at all times.
  - c. For borrow pit sites, the erosion and sediment control measures shall be designed, installed, operated, and maintained in accordance with the most recent version of the *North Carolina Surface Mining Manual*. Reclamation measures and implementation shall comply with the reclamation in accordance with the requirements of the Sedimentation Pollution Control Act and the Mining Act of 1971.
  - d. If the project occurs in waters or watersheds classified as Primary Nursery Areas (PNAs), SA, WS-1, WS-11, High Quality Waters (HQW), or Outstanding Resource Waters (ORW), then the sedimentation and erosion control designs shall comply with the requirements set forth in 15A NCAC 04B .0124, *Design Standards in Sensitive Watershed*. [15A NCAC 02H.0506(b)(3) and (c)(3); GC 4135]
12. Sediment and erosion control measures shall not be placed in wetlands or surface waters or within 5 feet of the top of bank without prior approval from DWR. [15A NCAC 02H.0506(b)(3) and (c)(3)]
13. Erosion control matting that incorporates plastic mesh and/or plastic twine shall not be used along streambanks or within wetlands. Exceptions to this condition require application to and written approval from DWR. [15A NCAC 02B .0201]
14. If placement of sediment and erosion control devices in wetlands and waters is unavoidable, then design and placement of temporary erosion control measures shall not be conducted in a manner that may result in dis-equilibrium of wetlands, stream beds, or banks, adjacent to or upstream and downstream of the above structures. All sediment and erosion control devices shall be removed from wetlands and waters and the natural grade restored within two (2) months of the date that the Division of Energy, Mining and Land Resources (DEMLR) or locally delegated program has released the specific area within the project. [15A NCAC 02H.0506(b)(3) and (c)(3)]
15. As a condition of this 401 Water Quality Certification, the bridge demolition and construction must be accomplished in strict compliance with the most recent version of NCDOT's Best Management Practices for Construction and Maintenance Activities. [15A NCAC 02H .0507(d)(2) and 15A NCAC 02H .0506(b)(5)]



16. Bridge deck drains shall not discharge directly into the stream. Stormwater shall be directed across the bridge and pre-treated through site-appropriate means (grassed swales, pre-formed scour holes, vegetated buffers, etc.) where possible before entering the stream. To meet the requirements of NCDOT's NPDES permit NCS0000250, please refer to the most recent version of the North Carolina Department of Transportation Stormwater Best Management Practices Toolbox manual for approved measures. [15A NCAC 02H .0507(d)(2) and 15A NCAC 02H .0506(b)(5)]
17. All bridge construction shall be performed from the existing bridge, temporary work bridges, temporary causeways, or floating or sunken barges. If work conditions require barges, they shall be floated into position and then sunk. The barges shall not be sunk and then dragged into position. Under no circumstances should barges be dragged along the bottom of the surface water. [15A NCAC 02H .0506(b)(3)]
18. Bridge piles and bents shall be constructed using driven piles (hammer or vibratory) or drilled shaft construction methods. More specifically, jetting or other methods of pile driving are prohibited without prior written approval from the NCDWR first. [15A NCAC 02H.0506(b)(2)]
19. A turbidity curtain will be installed in the stream if driving or drilling activities occur within the stream channel, on the stream bank, or within 5 feet of the top of bank, or during the removal of bents from an old bridge. This condition can be waived with prior approval from the NCDWR. [15A NCAC 02H .0506(b)(3)]
20. The use of rip-rap above the Normal High Water Mark shall be minimized. Any rip-rap placed for stream stabilization shall be placed in stream channels in such a manner that it does not impede aquatic life passage. [15A NCAC 02H.0506(b)(2)]
21. Any rip-rap required for proper culvert placement, stream stabilization, or restoration of temporarily disturbed areas shall be restricted to the area directly impacted by the approved construction activity. All rip-rap shall be placed such that the original streambed elevation and streambank contours are restored and maintained and shall consist of clean rock or masonry material free of debris or toxic pollutants. Placement of rip-rap or other approved materials shall not result in de-stabilization of the stream bed or banks upstream or downstream of the area or be installed in a manner that precludes aquatic life passage. [15A NCAC 02H .0506(b); 15A NCAC 02H .0507(c)]
22. Any rip-rap used for stream or shoreline stabilization shall be of a size and density to prevent movement by wave, current action, or stream flows, and shall consist of clean rock or masonry material free of debris or toxic pollutants. Rip-rap shall not be installed in the streambed except in specific areas required for velocity control and to ensure structural integrity of bank stabilization measures. [15A NCAC 02H .0506(b); 15A NCAC 02H .0507(c); 15A NCAC 02B .0201]
23. Channel relocations shall be completed and stabilized, and approved on site by NCDWR staff, prior to diverting water into the new channel. Stream banks shall be matted with coir-fiber matting. Vegetation used for bank stabilization shall be limited to native riparian vegetation, and should include establishment of a vegetated buffer on both sides of the relocated channel to the maximum extent practical. Also, rip-rap may be allowed if it is necessary to maintain the physical integrity of the stream, but the applicant must provide written justification and any calculations used to determine the extent



of rip-rap coverage requested. Once the stream has been turned into the new channel, it may be necessary to relocate stranded fish to the new channel to prevent fish kills. [15A NCAC 02H .0506(b)(3)]

24. No drill slurry or water that has been in contact with uncured concrete shall be allowed to enter surface waters. This water shall be captured, treated, and disposed of properly. [15A NCAC 02H .0506(b)(3)]
25. Native riparian vegetation must be reestablished in the riparian areas within the construction limits of the project by the end of the growing season following completion of construction. [15A NCAC 02H.0506(b)(2)]
26. Discharging hydroseed mixtures and washing out hydroseeders and other equipment in or adjacent to surface waters is prohibited. [15A NCAC 02H.0506(b)(3)]
27. NCDOT shall be in compliance with the NCS00250 issued to the NCDOT, including the applicable requirements of the NCG01000.
28. The permittee and its authorized agents shall conduct its activities in a manner consistent with State water quality standards (including any requirements resulting from compliance with §303(d) of the Clean Water Act) and any other appropriate requirements of State and Federal law. If the NCDWR determines that such standards or laws are not being met (including the failure to sustain a designated or achieved use) or that State or federal law is being violated, or that further conditions are necessary to assure compliance, the NCDWR may reevaluate and modify this certification. [15A NCAC 02B.0200]
29. The Permittee shall report any violations of this certification to the Division of Water Resources within 24 hours of discovery. [15A NCAC 02B.0506(b)(2)]
30. The NCDOT will conduct a pre-construction meeting with all appropriate staff to ensure that the project supervisor and essential staff understand the permit conditions and any potential issues at the permitted site. NCDWR staff shall be invited to the pre-construction meeting. [15A NCAC 02H.0506(b)(2) and (b)(3)]
31. Upon completion of the project (including any impacts at associated borrow or waste sites), the NCDOT Division Engineer shall complete the "Certification of Completion Form" to notify the NCDWR when all work included in the 401 Certification has been completed. [15A NCAC 02H.0502(f)]
32. A copy of this Water Quality Certification shall be maintained on the construction site at all times. In addition, the Water Quality Certification and all subsequent modifications, if any, shall be maintained with the Division Engineer and the on-site project manager. [15A NCAC 02H .0507(c) and 15A NCAC 02H .0506 (b)(2) and (c)(2)] .

This approval and its conditions are final and binding unless contested [G.S. 143-215.5]. Please be aware that impacting waters without first applying for and securing the issuance of a 401 Water Quality Certification violates Title 15A of the North Carolina Administrative Code (NCAC) 2H .0500. Title 15A NCAC 2H .0500 requires certifications pursuant to Section 401 of the Clean Water Act whenever construction or operation of facilities will result in a discharge into navigable waters, including wetlands, as described in 33 Code of Federal Regulations (CFR) Part 323. It also states any person desiring issuance of the State certification or coverage under a general certification required by Section 401 of



the Federal Water Pollution Control Act shall file with the Director of the North Carolina Division of Water Quality. Pursuant to G.S. 143-215.6A, these violations and any future violations are subject to a civil penalty assessment of up to a maximum of \$25,000.00 per day for each violation.

This Certification can be contested as provided in Chapter 150B of the North Carolina General Statutes by filing a Petition for a Contested Case Hearing (Petition) with the North Carolina Office of Administrative Hearings (OAH) within sixty (60) calendar days. Requirements for filing a Petition are set forth in Chapter 150B of the North Carolina General Statutes and Title 26 of the North Carolina Administrative Code. Additional information regarding requirements for filing a Petition and Petition forms may be accessed at <http://www.ncoah.com/> or by calling the OAH Clerk's Office at (919) 431-3000.

A party filing a Petition must serve a copy of the Petition on:

William F. Lane, General Counsel  
Department of Environmental Quality  
1601 Mail Service Center  
Raleigh, NC 27699-1601

If the party filing the Petition is not the permittee, then the party must also serve the recipient of the Certification in accordance with N.C.G.S 150B-23(a).

This letter completes the review of the Division under section 401 of the Clean Water Act and 15A NCAC 02H .0500. Please contact Hannah Sprinkle at [hannah.sprinkle@deq.nc.gov](mailto:hannah.sprinkle@deq.nc.gov) if you have any questions or concerns.

Sincerely,

DocuSigned by:  
  
4F4DD2F21EA846E...

Richard E. Rogers, Jr., Director  
Division of Water Resources

cc:

Eric Alsmeyer, USACE Raleigh Regulatory Field Office (via email)  
Gary Jordan, US Fish and Wildlife Service  
Travis Wilson, NC Wildlife Resources Commission  
Beth Harmon, Division of Mitigation Services  
Hannah Sprinkle, NC Division of Water Resources Wilmington Regional Office  
File Copy



STATE OF NORTH CAROLINA  
DIVISION OF HIGHWAYS

CUMBERLAND COUNTY

LOCATION: SR 1003 (Camden Road) from Future I-295  
(Fayetteville Outer Loop) To NC 59 (Hope Mills Road)

TYPE OF WORK: GRADING, PAVING, DRAINAGE AND SIGNALS

U-3422  
STREAM AND WETLAND IMPACTS

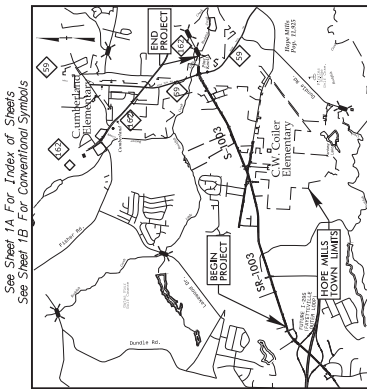

VICINITY MAP  
(NOT TO SCALE)

STATE	N.C.	PROJECT NUMBER	U-3422	SHEET	1	TOTAL SHEETS	1
PROJECT NAME	SR 1003 (CAMDEN RD) FROM FUTURE I-295 (FAYETTEVILLE OUTER LOOP) TO NC 59 (HOPE MILLS RD)						
DATE	P.E.						
DATE	ROW						
DATE	UTILITIES						
DATE	CONSTRUCTION						

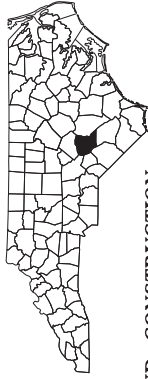

END CONSTRUCTION  
TIP PROJECT U-3422  
END MILL/FILL  
(APPROX 1405' E. OF END GRADE)  
BEGIN EXISTING BRIDGE

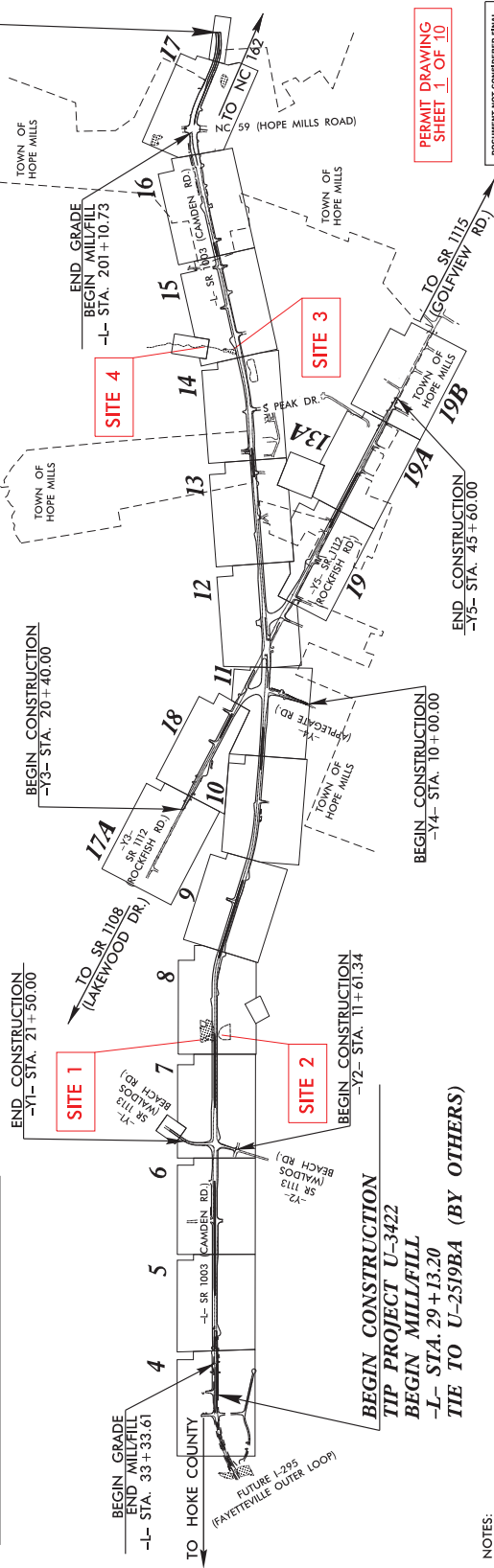

PERMIT DRAWING  
SHEET 1 OF 10

DOCUMENT NOT CONSIDERED FINAL  
UNLESS ALL SIGNATURES COMPLETED

**HDR**  
HDR Engineering, Inc. of the Carolinas  
10000 Old Salem Rd., Suite 300, Raleigh, NC 27603  
N.C. REG. LICENSE NO. 1-47116

PROJECT ENGINEER  
**PHILIP E. ROGERS, PE**

PROJECT DESIGN ENGINEER  
**ALEXANDER D. SNIDER, PE**

PROJECT DESIGN ENGINEER  
**SEAN MATUSZEWSKI, PE**

HYDRAULICS ENGINEER

ROADWAY DESIGN ENGINEER

Prepared by the Office of:  
HDR Engineering, Inc. of the Carolinas  
10000 Old Salem Rd., Suite 300, Raleigh, NC 27603  
N.C. REG. LICENSE NO. 1-47116

RIGHT OF WAY DATE:  
JULY 30, 2021

LETTING DATE:  
OCTOBER 17, 2023

STANDARD SPECIFICATIONS	PROJECT LENGTH
LENGTH ROADWAY TIP PROJECT U-3422 = 3.514 MILES	LENGTH STRUCTURE TIP PROJECT U-3422 = 0.000 MILES
TOTAL LENGTH TIP PROJECT U-3422 = 3.514 MILES	

DESIGN DATA
ADT 2017 = 26,100
ADT 2040 = 38,500
K = 9 %
D = 60 %
T = 4 %
V = 50 MPH
(* TTST 1% + DUAL 3%)
FUNC CLASS = MINOR ARTERIAL
STATEWIDE TIER



NOTES:  
THIS PROJECT HAS PARTIALLY CONTROLLED ACCESS WITH ACCESS BEING LIMITED TO POINTS SHOWN ON THE PLANS.

CONTRACT: TIP PROJECT: U-3422

REVISIONS

10/27/2022: PARCELS 2C EASEMENTS REMOVED; PARCELS 6A-6F & 7I-7J CARVEMENTS REVERSED

11/21/2022: PARCELS 1A, 1B, 1C, 1D, 1E, 1F, 1G, 1H, 1I, 1J, 1K, 1L, 1M, 1N, 1O, 1P, 1Q, 1R, 1S, 1T, 1U, 1V, 1W, 1X, 1Y, 1Z, 2A, 2B, 2C, 2D, 2E, 2F, 2G, 2H, 2I, 2J, 2K, 2L, 2M, 2N, 2O, 2P, 2Q, 2R, 2S, 2T, 2U, 2V, 2W, 2X, 2Y, 2Z, 3A, 3B, 3C, 3D, 3E, 3F, 3G, 3H, 3I, 3J, 3K, 3L, 3M, 3N, 3O, 3P, 3Q, 3R, 3S, 3T, 3U, 3V, 3W, 3X, 3Y, 3Z, 4A, 4B, 4C, 4D, 4E, 4F, 4G, 4H, 4I, 4J, 4K, 4L, 4M, 4N, 4O, 4P, 4Q, 4R, 4S, 4T, 4U, 4V, 4W, 4X, 4Y, 4Z, 5A, 5B, 5C, 5D, 5E, 5F, 5G, 5H, 5I, 5J, 5K, 5L, 5M, 5N, 5O, 5P, 5Q, 5R, 5S, 5T, 5U, 5V, 5W, 5X, 5Y, 5Z, 6A, 6B, 6C, 6D, 6E, 6F, 6G, 6H, 6I, 6J, 6K, 6L, 6M, 6N, 6O, 6P, 6Q, 6R, 6S, 6T, 6U, 6V, 6W, 6X, 6Y, 6Z, 7A, 7B, 7C, 7D, 7E, 7F, 7G, 7H, 7I, 7J, 7K, 7L, 7M, 7N, 7O, 7P, 7Q, 7R, 7S, 7T, 7U, 7V, 7W, 7X, 7Y, 7Z, 8A, 8B, 8C, 8D, 8E, 8F, 8G, 8H, 8I, 8J, 8K, 8L, 8M, 8N, 8O, 8P, 8Q, 8R, 8S, 8T, 8U, 8V, 8W, 8X, 8Y, 8Z, 9A, 9B, 9C, 9D, 9E, 9F, 9G, 9H, 9I, 9J, 9K, 9L, 9M, 9N, 9O, 9P, 9Q, 9R, 9S, 9T, 9U, 9V, 9W, 9X, 9Y, 9Z, 10A, 10B, 10C, 10D, 10E, 10F, 10G, 10H, 10I, 10J, 10K, 10L, 10M, 10N, 10O, 10P, 10Q, 10R, 10S, 10T, 10U, 10V, 10W, 10X, 10Y, 10Z, 11A, 11B, 11C, 11D, 11E, 11F, 11G, 11H, 11I, 11J, 11K, 11L, 11M, 11N, 11O, 11P, 11Q, 11R, 11S, 11T, 11U, 11V, 11W, 11X, 11Y, 11Z, 12A, 12B, 12C, 12D, 12E, 12F, 12G, 12H, 12I, 12J, 12K, 12L, 12M, 12N, 12O, 12P, 12Q, 12R, 12S, 12T, 12U, 12V, 12W, 12X, 12Y, 12Z, 13A, 13B, 13C, 13D, 13E, 13F, 13G, 13H, 13I, 13J, 13K, 13L, 13M, 13N, 13O, 13P, 13Q, 13R, 13S, 13T, 13U, 13V, 13W, 13X, 13Y, 13Z, 14A, 14B, 14C, 14D, 14E, 14F, 14G, 14H, 14I, 14J, 14K, 14L, 14M, 14N, 14O, 14P, 14Q, 14R, 14S, 14T, 14U, 14V, 14W, 14X, 14Y, 14Z, 15A, 15B, 15C, 15D, 15E, 15F, 15G, 15H, 15I, 15J, 15K, 15L, 15M, 15N, 15O, 15P, 15Q, 15R, 15S, 15T, 15U, 15V, 15W, 15X, 15Y, 15Z, 16A, 16B, 16C, 16D, 16E, 16F, 16G, 16H, 16I, 16J, 16K, 16L, 16M, 16N, 16O, 16P, 16Q, 16R, 16S, 16T, 16U, 16V, 16W, 16X, 16Y, 16Z, 17A, 17B, 17C, 17D, 17E, 17F, 17G, 17H, 17I, 17J, 17K, 17L, 17M, 17N, 17O, 17P, 17Q, 17R, 17S, 17T, 17U, 17V, 17W, 17X, 17Y, 17Z, 18A, 18B, 18C, 18D, 18E, 18F, 18G, 18H, 18I, 18J, 18K, 18L, 18M, 18N, 18O, 18P, 18Q, 18R, 18S, 18T, 18U, 18V, 18W, 18X, 18Y, 18Z, 19A, 19B, 19C, 19D, 19E, 19F, 19G, 19H, 19I, 19J, 19K, 19L, 19M, 19N, 19O, 19P, 19Q, 19R, 19S, 19T, 19U, 19V, 19W, 19X, 19Y, 19Z, 20A, 20B, 20C, 20D, 20E, 20F, 20G, 20H, 20I, 20J, 20K, 20L, 20M, 20N, 20O, 20P, 20Q, 20R, 20S, 20T, 20U, 20V, 20W, 20X, 20Y, 20Z, 21A, 21B, 21C, 21D, 21E, 21F, 21G, 21H, 21I, 21J, 21K, 21L, 21M, 21N, 21O, 21P, 21Q, 21R, 21S, 21T, 21U, 21V, 21W, 21X, 21Y, 21Z, 22A, 22B, 22C, 22D, 22E, 22F, 22G, 22H, 22I, 22J, 22K, 22L, 22M, 22N, 22O, 22P, 22Q, 22R, 22S, 22T, 22U, 22V, 22W, 22X, 22Y, 22Z, 23A, 23B, 23C, 23D, 23E, 23F, 23G, 23H, 23I, 23J, 23K, 23L, 23M, 23N, 23O, 23P, 23Q, 23R, 23S, 23T, 23U, 23V, 23W, 23X, 23Y, 23Z, 24A, 24B, 24C, 24D, 24E, 24F, 24G, 24H, 24I, 24J, 24K, 24L, 24M, 24N, 24O, 24P, 24Q, 24R, 24S, 24T, 24U, 24V, 24W, 24X, 24Y, 24Z, 25A, 25B, 25C, 25D, 25E, 25F, 25G, 25H, 25I, 25J, 25K, 25L, 25M, 25N, 25O, 25P, 25Q, 25R, 25S, 25T, 25U, 25V, 25W, 25X, 25Y, 25Z, 26A, 26B, 26C, 26D, 26E, 26F, 26G, 26H, 26I, 26J, 26K, 26L, 26M, 26N, 26O, 26P, 26Q, 26R, 26S, 26T, 26U, 26V, 26W, 26X, 26Y, 26Z, 27A, 27B, 27C, 27D, 27E, 27F, 27G, 27H, 27I, 27J, 27K, 27L, 27M, 27N, 27O, 27P, 27Q, 27R, 27S, 27T, 27U, 27V, 27W, 27X, 27Y, 27Z, 28A, 28B, 28C, 28D, 28E, 28F, 28G, 28H, 28I, 28J, 28K, 28L, 28M, 28N, 28O, 28P, 28Q, 28R, 28S, 28T, 28U, 28V, 28W, 28X, 28Y, 28Z, 29A, 29B, 29C, 29D, 29E, 29F, 29G, 29H, 29I, 29J, 29K, 29L, 29M, 29N, 29O, 29P, 29Q, 29R, 29S, 29T, 29U, 29V, 29W, 29X, 29Y, 29Z, 30A, 30B, 30C, 30D, 30E, 30F, 30G, 30H, 30I, 30J, 30K, 30L, 30M, 30N, 30O, 30P, 30Q, 30R, 30S, 30T, 30U, 30V, 30W, 30X, 30Y, 30Z, 31A, 31B, 31C, 31D, 31E, 31F, 31G, 31H, 31I, 31J, 31K, 31L, 31M, 31N, 31O, 31P, 31Q, 31R, 31S, 31T, 31U, 31V, 31W, 31X, 31Y, 31Z, 32A, 32B, 32C, 32D, 32E, 32F, 32G, 32H, 32I, 32J, 32K, 32L, 32M, 32N, 32O, 32P, 32Q, 32R, 32S, 32T, 32U, 32V, 32W, 32X, 32Y, 32Z, 33A, 33B, 33C, 33D, 33E, 33F, 33G, 33H, 33I, 33J, 33K, 33L, 33M, 33N, 33O, 33P, 33Q, 33R, 33S, 33T, 33U, 33V, 33W, 33X, 33Y, 33Z, 34A, 34B, 34C, 34D, 34E, 34F, 34G, 34H, 34I, 34J, 34K, 34L, 34M, 34N, 34O, 34P, 34Q, 34R, 34S, 34T, 34U, 34V, 34W, 34X, 34Y, 34Z, 35A, 35B, 35C, 35D, 35E, 35F, 35G, 35H, 35I, 35J, 35K, 35L, 35M, 35N, 35O, 35P, 35Q, 35R, 35S, 35T, 35U, 35V, 35W, 35X, 35Y, 35Z, 36A, 36B, 36C, 36D, 36E, 36F, 36G, 36H, 36I, 36J, 36K, 36L, 36M, 36N, 36O, 36P, 36Q, 36R, 36S, 36T, 36U, 36V, 36W, 36X, 36Y, 36Z, 37A, 37B, 37C, 37D, 37E, 37F, 37G, 37H, 37I, 37J, 37K, 37L, 37M, 37N, 37O, 37P, 37Q, 37R, 37S, 37T, 37U, 37V, 37W, 37X, 37Y, 37Z, 38A, 38B, 38C, 38D, 38E, 38F, 38G, 38H, 38I, 38J, 38K, 38L, 38M, 38N, 38O, 38P, 38Q, 38R, 38S, 38T, 38U, 38V, 38W, 38X, 38Y, 38Z, 39A, 39B, 39C, 39D, 39E, 39F, 39G, 39H, 39I, 39J, 39K, 39L, 39M, 39N, 39O, 39P, 39Q, 39R, 39S, 39T, 39U, 39V, 39W, 39X, 39Y, 39Z, 40A, 40B, 40C, 40D, 40E, 40F, 40G, 40H, 40I, 40J, 40K, 40L, 40M, 40N, 40O, 40P, 40Q, 40R, 40S, 40T, 40U, 40V, 40W, 40X, 40Y, 40Z, 41A, 41B, 41C, 41D, 41E, 41F, 41G, 41H, 41I, 41J, 41K, 41L, 41M, 41N, 41O, 41P, 41Q, 41R, 41S, 41T, 41U, 41V, 41W, 41X, 41Y, 41Z, 42A, 42B, 42C, 42D, 42E, 42F, 42G, 42H, 42I, 42J, 42K, 42L, 42M, 42N, 42O, 42P, 42Q, 42R, 42S, 42T, 42U, 42V, 42W, 42X, 42Y, 42Z, 43A, 43B, 43C, 43D, 43E, 43F, 43G, 43H, 43I, 43J, 43K, 43L, 43M, 43N, 43O, 43P, 43Q, 43R, 43S, 43T, 43U, 43V, 43W, 43X, 43Y, 43Z, 44A, 44B, 44C, 44D, 44E, 44F, 44G, 44H, 44I, 44J, 44K, 44L, 44M, 44N, 44O, 44P, 44Q, 44R, 44S, 44T, 44U, 44V, 44W, 44X, 44Y, 44Z, 45A, 45B, 45C, 45D, 45E, 45F, 45G, 45H, 45I, 45J, 45K, 45L, 45M, 45N, 45O, 45P, 45Q, 45R, 45S, 45T, 45U, 45V, 45W, 45X, 45Y, 45Z, 46A, 46B, 46C, 46D, 46E, 46F, 46G, 46H, 46I, 46J, 46K, 46L, 46M, 46N, 46O, 46P, 46Q, 46R, 46S, 46T, 46U, 46V, 46W, 46X, 46Y, 46Z, 47A, 47B, 47C, 47D, 47E, 47F, 47G, 47H, 47I, 47J, 47K, 47L, 47M, 47N, 47O, 47P, 47Q, 47R, 47S, 47T, 47U, 47V, 47W, 47X, 47Y, 47Z, 48A, 48B, 48C, 48D, 48E, 48F, 48G, 48H, 48I, 48J, 48K, 48L, 48M, 48N, 48O, 48P, 48Q, 48R, 48S, 48T, 48U, 48V, 48W, 48X, 48Y, 48Z, 49A, 49B, 49C, 49D, 49E, 49F, 49G, 49H, 49I, 49J, 49K, 49L, 49M, 49N, 49O, 49P, 49Q, 49R, 49S, 49T, 49U, 49V, 49W, 49X, 49Y, 49Z, 50A, 50B, 50C, 50D, 50E, 50F, 50G, 50H, 50I, 50J, 50K, 50L, 50M, 50N, 50O, 50P, 50Q, 50R, 50S, 50T, 50U, 50V, 50W, 50X, 50Y, 50Z, 51A, 51B, 51C, 51D, 51E, 51F, 51G, 51H, 51I, 51J, 51K, 51L, 51M, 51N, 51O, 51P, 51Q, 51R, 51S, 51T, 51U, 51V, 51W, 51X, 51Y, 51Z, 52A, 52B, 52C, 52D, 52E, 52F, 52G, 52H, 52I, 52J, 52K, 52L, 52M, 52N, 52O, 52P, 52Q, 52R, 52S, 52T, 52U, 52V, 52W, 52X, 52Y, 52Z, 53A, 53B, 53C, 53D, 53E, 53F, 53G, 53H, 53I, 53J, 53K, 53L, 53M, 53N, 53O, 53P, 53Q, 53R, 53S, 53T, 53U, 53V, 53W, 53X, 53Y, 53Z, 54A, 54B, 54C, 54D, 54E, 54F, 54G, 54H, 54I, 54J, 54K, 54L, 54M, 54N, 54O, 54P, 54Q, 54R, 54S, 54T, 54U, 54V, 54W, 54X, 54Y, 54Z, 55A, 55B, 55C, 55D, 55E, 55F, 55G, 55H, 55I, 55J, 55K, 55L, 55M, 55N, 55O, 55P, 55Q, 55R, 55S, 55T, 55U, 55V, 55W, 55X, 55Y, 55Z, 56A, 56B, 56C, 56D, 56E, 56F, 56G, 56H, 56I, 56J, 56K, 56L, 56M, 56N, 56O, 56P, 56Q, 56R, 56S, 56T, 56U, 56V, 56W, 56X, 56Y, 56Z, 57A, 57B, 57C, 57D, 57E, 57F, 57G, 57H, 57I, 57J, 57K, 57L, 57M, 57N, 57O, 57P, 57Q, 57R, 57S, 57T, 57U, 57V, 57W, 57X, 57Y, 57Z, 58A, 58B, 58C, 58D, 58E, 58F, 58G, 58H, 58I, 58J, 58K, 58L, 58M, 58N, 58O, 58P, 58Q, 58R, 58S, 58T, 58U, 58V, 58W, 58X, 58Y, 58Z, 59A, 59B, 59C, 59D, 59E, 59F, 59G, 59H, 59I, 59J, 59K, 59L, 59M, 59N, 59O, 59P, 59Q, 59R, 59S, 59T, 59U, 59V, 59W, 59X, 59Y, 59Z, 60A, 60B, 60C, 60D, 60E, 60F, 60G, 60H, 60I, 60J, 60K, 60L, 60M, 60N, 60O, 60P, 60Q, 60R, 60S, 60T, 60U, 60V, 60W, 60X, 60Y, 60Z, 61A, 61B, 61C, 61D, 61E, 61F, 61G, 61H, 61I, 61J, 61K, 61L, 61M, 61N, 61O, 61P, 61Q, 61R, 61S, 61T, 61U, 61V, 61W, 61X, 61Y, 61Z, 62A, 62B, 62C, 62D, 62E, 62F, 62G, 62H, 62I, 62J, 62K, 62L, 62M, 62N, 62O, 62P, 62Q, 62R, 62S, 62T, 62U, 62V, 62W, 62X, 62Y, 62Z, 63A, 63B, 63C, 63D, 63E, 63F, 63G, 63H, 63I, 63J, 63K, 63L, 63M, 63N, 63O, 63P, 63Q, 63R, 63S, 63T, 63U, 63V, 63W, 63X, 63Y, 63Z, 64A, 64B, 64C, 64D, 64E, 64F, 64G, 64H, 64I, 64J, 64K, 64L, 64M, 64N, 64O, 64P, 64Q, 64R, 64S, 64T, 64U, 64V, 64W, 64X, 64Y, 64Z, 65A, 65B, 65C, 65D, 65E, 65F, 65G, 65H, 65I, 65J, 65K, 65L, 65M, 65N, 65O, 65P, 65Q, 65R, 65S, 65T, 65U, 65V, 65W, 65X, 65Y, 65Z, 66A, 66B, 66C, 66D, 66E, 66F, 66G, 66H, 66I, 66J, 66K, 66L, 66M, 66N, 66O, 66P, 66Q, 66R, 66S, 66T, 66U, 66V, 66W, 66X, 66Y, 66Z, 67A, 67B, 67C, 67D, 67E, 67F, 67G, 67H, 67I, 67J, 67K, 67L, 67M, 67N, 67O, 67P, 67Q, 67R, 67S, 67T, 67U, 67V, 67W, 67X, 67Y, 67Z, 68A, 68B, 68C, 68D, 68E, 68F, 68G, 68H, 68I, 68J, 68K, 68L, 68M, 68N, 68O, 68P, 68Q, 68R, 68S, 68T, 68U, 68V, 68W, 68X, 68Y, 68Z, 69A, 69B, 69C, 69D, 69E, 69F, 69G, 69H, 69I, 69J, 69K, 69L, 69M, 69N, 69O, 69P, 69Q, 69R, 69S, 69T, 69U, 69V, 69W, 69X, 69Y, 69Z, 70A, 70B, 70C, 70D, 70E, 70F, 70G, 70H, 70I, 70J, 70K, 70L, 70M, 70N, 70O, 70P, 70Q, 70R, 70S, 70T, 70U, 70V, 70W, 70X, 70Y, 70Z, 71A, 71B, 71C, 71D, 71E, 71F, 71G, 71H, 71I, 71J, 71K, 71L, 71M, 71N, 71O, 71P, 71Q, 71R, 71S, 71T, 71U, 71V, 71W, 71X, 71Y, 71Z, 72A, 72B, 72C, 72D, 72E, 72F, 72G, 72H, 72I, 72J, 72K, 72L, 72M, 72N, 72O, 72P, 72Q, 72R, 72S, 72T, 72U, 72V, 72W, 72X, 72Y, 72Z, 73A, 73B, 73C, 73D, 73E, 73F, 73G, 73H, 73I, 73J, 73K, 73L, 73M, 73N, 73O, 73P, 73Q, 73R, 73S, 73T, 73U, 73V, 73W, 73X, 73Y, 73Z, 74A, 74B, 74C, 74D, 74E, 74F, 74G, 74H, 74I, 74J, 74K, 74L, 74M, 74N, 74O, 74P, 74Q, 74R, 74S, 74T, 74U, 74V, 74W, 74X, 74Y, 74Z, 75A, 75B, 75C, 75D, 75E, 75F, 75G, 75H, 75I, 75J, 75K, 75L, 75M, 75N, 75O, 75P, 75Q, 75R, 75S, 75T, 75U, 75V, 75W, 75X, 75Y, 75Z, 76A, 76B, 76C, 76D, 76E, 76F, 76G, 76H, 76I, 76J, 76K, 76L, 76M, 76N, 76O, 76P, 76Q, 76R, 76S, 76T, 76U, 76V, 76W, 76X, 76Y, 76Z, 77A, 77B, 77C, 77D, 77E, 77F, 77G, 77H, 77I, 77J, 77K, 77L, 77M, 77N, 77O, 77P, 77Q, 77R, 77S, 77T, 77U, 77V, 77W, 77X, 77Y, 77Z, 78A, 78B, 78C, 78D, 78E, 78F, 78G, 78H, 78I, 78J, 78K, 78L, 78M, 78N, 78O, 78P, 78Q, 78R, 78S, 78T, 78U, 78V, 78W, 78X, 78Y, 78Z, 79A, 79B, 79C, 79D, 79E, 79F, 79G, 79H, 79I, 79J, 79K, 79L, 79M, 79N, 79O, 79P, 79Q, 79R, 79S, 79T, 79U, 79V, 79W, 79X, 79Y, 79Z, 80A, 80B, 80C, 80D, 80E, 80F, 80G, 80H, 80I, 80J, 80K, 80L, 80M, 80N, 80O, 80P, 80Q, 80R, 80S, 80T, 80U, 80V, 80W, 80X, 80Y, 80Z, 81A, 81B, 81C, 81D, 81E, 81F, 81G, 81H, 81I, 81J, 81K, 81L, 81M, 81N, 81O, 81P, 81Q, 81R, 81S, 81T,









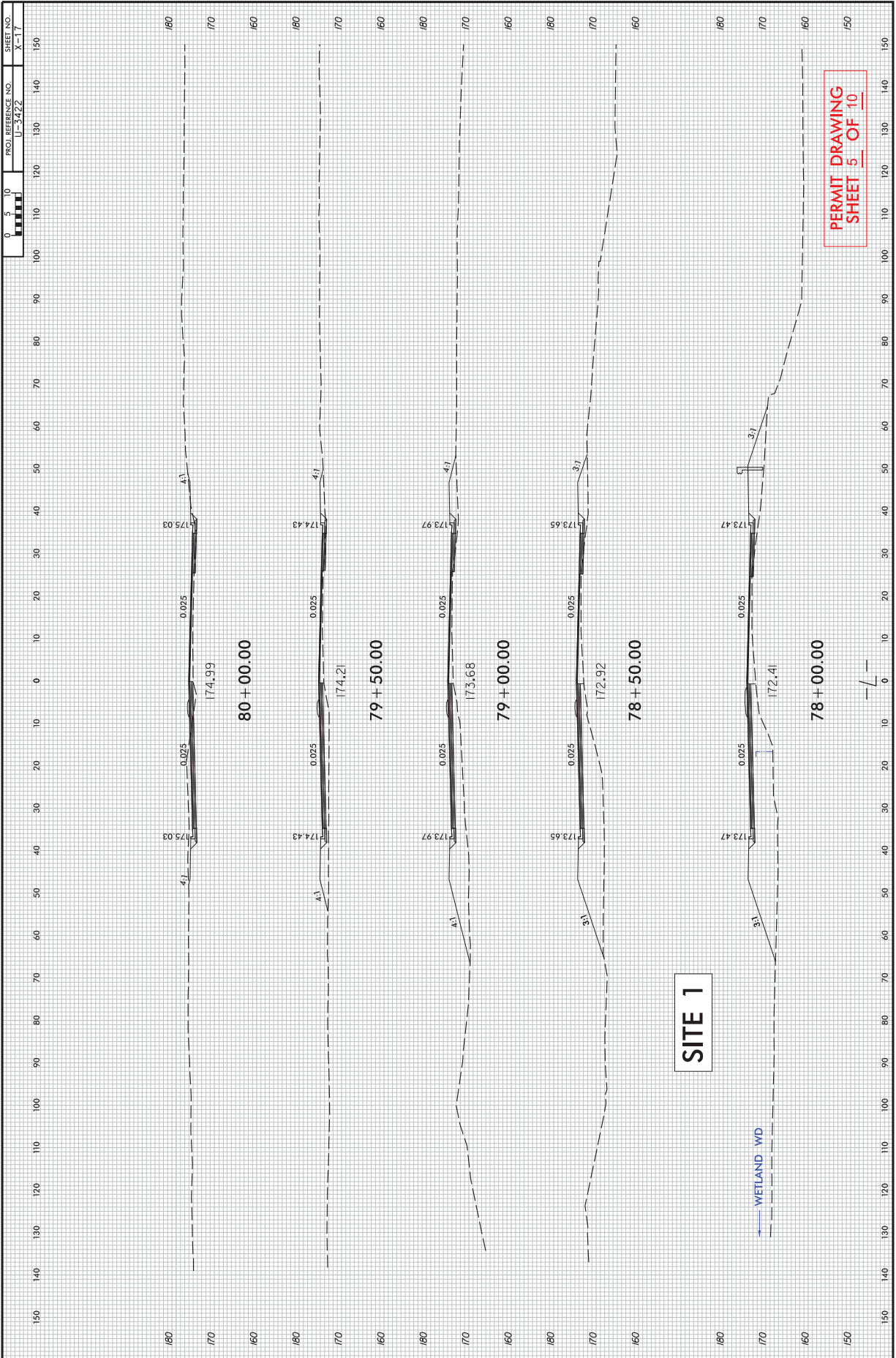

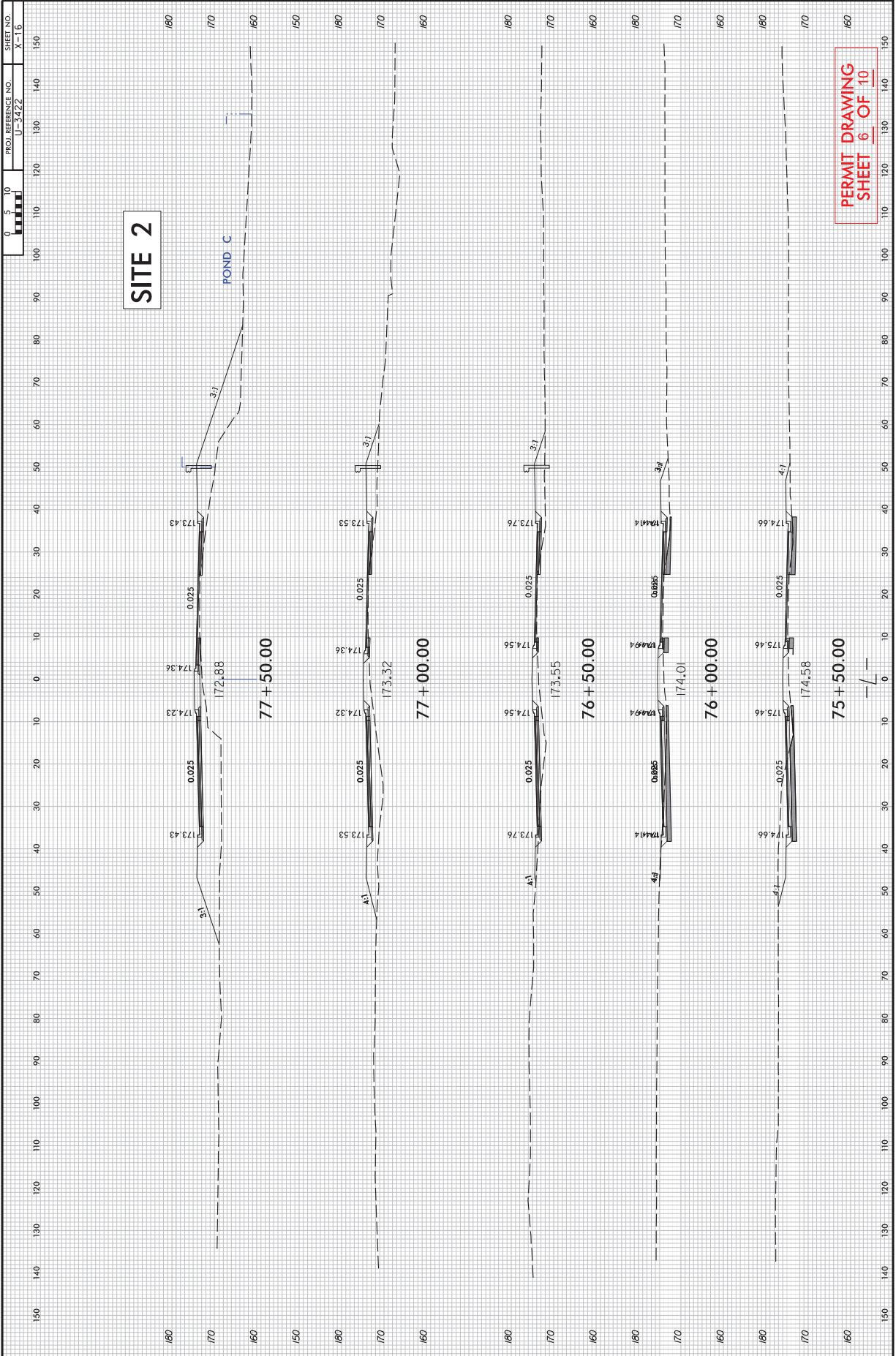

PERMIT DRAWING  
 SHEET 6 OF 10

PERMIT DRAWING  
SHEET 7 OF 10

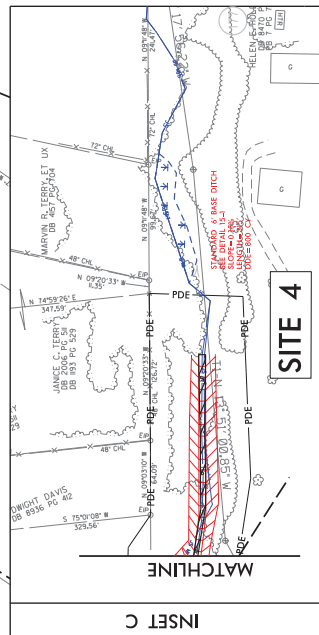
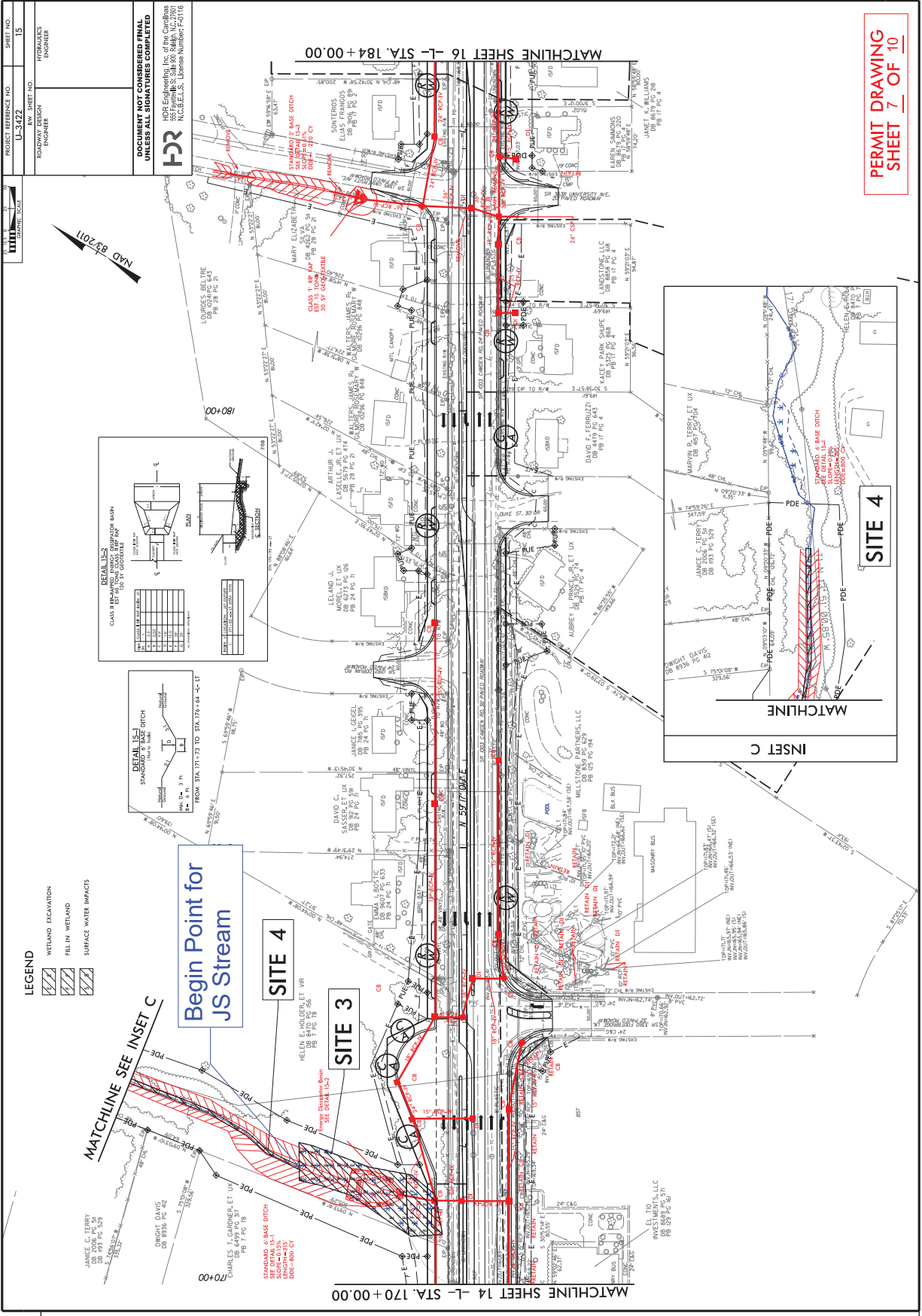

REVISIONS

9/30/2021	PARCEL OWNERS ADOPTED PARCELS 184 AND 183-194; TCE REVISED ON PARCEL 184
11/30/2021	PARCEL 185
3/25/2022	PARCELS 169, 172-174, 175, 176, 177, 178, 179, 180, 181, 182, 183, 184, 185, 186, 187, 188, 189, 190, 191, 192, 193, 194
8/10/2022	PARCELS 171, 172, 173, 174, 175, 176, 177, 178, 179, 180, 181, 182, 183, 184, 185, 186, 187, 188, 189, 190, 191, 192, 193, 194
1/12/2023	PARCELS 169 & 177 PARCELS 189, 190, 192, 193 & 194
3/2/2023	PARCEL 184 CHANGED TO PARCEL 183; OWNERS 183 HAVE CHANGED

FILED: MCDOT\2015.MCDOT\1501.F01\Planning\Design\15.MCDOT-U-3422-1\60.CAD\B\W\2.MK\1.InProgress\U-3422\Hydro\culverts\PERMITS\Environment\Drawings\U3422.HXD.PRD.MET.P54.dgn

PENITABLE: MCDOT\permits\NCONC\TBI

USER: CMYRS

DATE: 5/9/2023

TIME: 10:00:02 AM

PROJECT REFERENCE NO. U-3422

R/W SHEET NO. 15

DESIGNER: MCDOT

ENGINEER: HOWALD

ENGINEER: ENGINEER

DOCUMENT NOT CONSIDERED FINAL UNLESS ALL SIGNATURES COMPLETED

HPR

HPR Engineering, Inc. of the Carolinas  
10000 N. CENTRAL EXP. WY.  
SUITE 100  
N.C. 27615-1000  
N.C. REG. NO. 10000  
LICENSE NUMBER F-21176

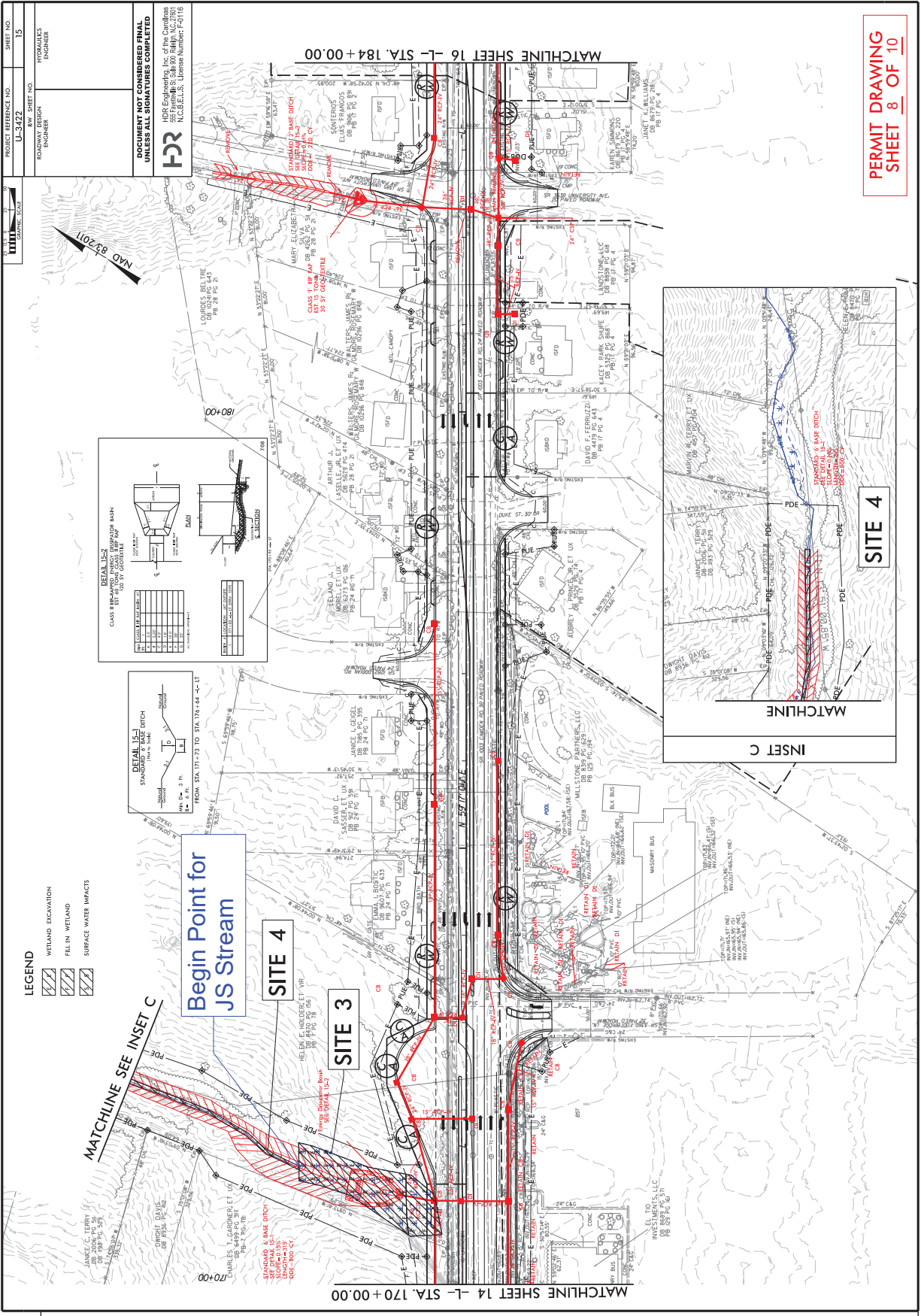

PERMIT DRAWING  
SHEET 8 OF 10

REVISIONS

9/20/2021 PARCEL OWNERS ADDED; PARCELS 184 AND 183-194; TCE REVISED ON PARCEL 184

3/25/2023 PARCELS 169-172-174, 175, 176, 177, 180, 181, 184, 185, 187, 188 PUE REVISED; PARCELS 169, 172, 174 DUE REMOVAL; PARCEL 175 TCE REMOVED AND DUE REVISED; PARCELS 163, 170, 171, 172, 173, 174, 175, 176, 177, 180, 181, 184, 185, 187, 188 PUE REVISED.

8/10/2022 PARCELS 171, 174, 175, 177, 180, 181, & 183 NOW REVISED; PARCEL 177 PUE REVISED, AND TCE REVISED

1/12/2023 PUE REVISED ON PARCELS 169 & 177 PARCELS 189, 190, 192, 193 & 194

9/2/2023 PARCEL 184 CHANGED TO PARCEL 183; OWNERS 183 NAME CHANGED

FILE: MCD01\2015\_MCD01\_Color.dwg; PLOT: MCD01\2015\_MCD01\_Color.dwg; PLOT: MCD01\2015\_MCD01\_Color.dwg; PLOT: MCD01\2015\_MCD01\_Color.dwg

PENLTABLE: MCD01\_Color.dwg; PLOT: MCD01\2015\_MCD01\_Color.dwg

DATE: 5/9/2023 TIME: 9:58:05 AM

USER: CMYERS

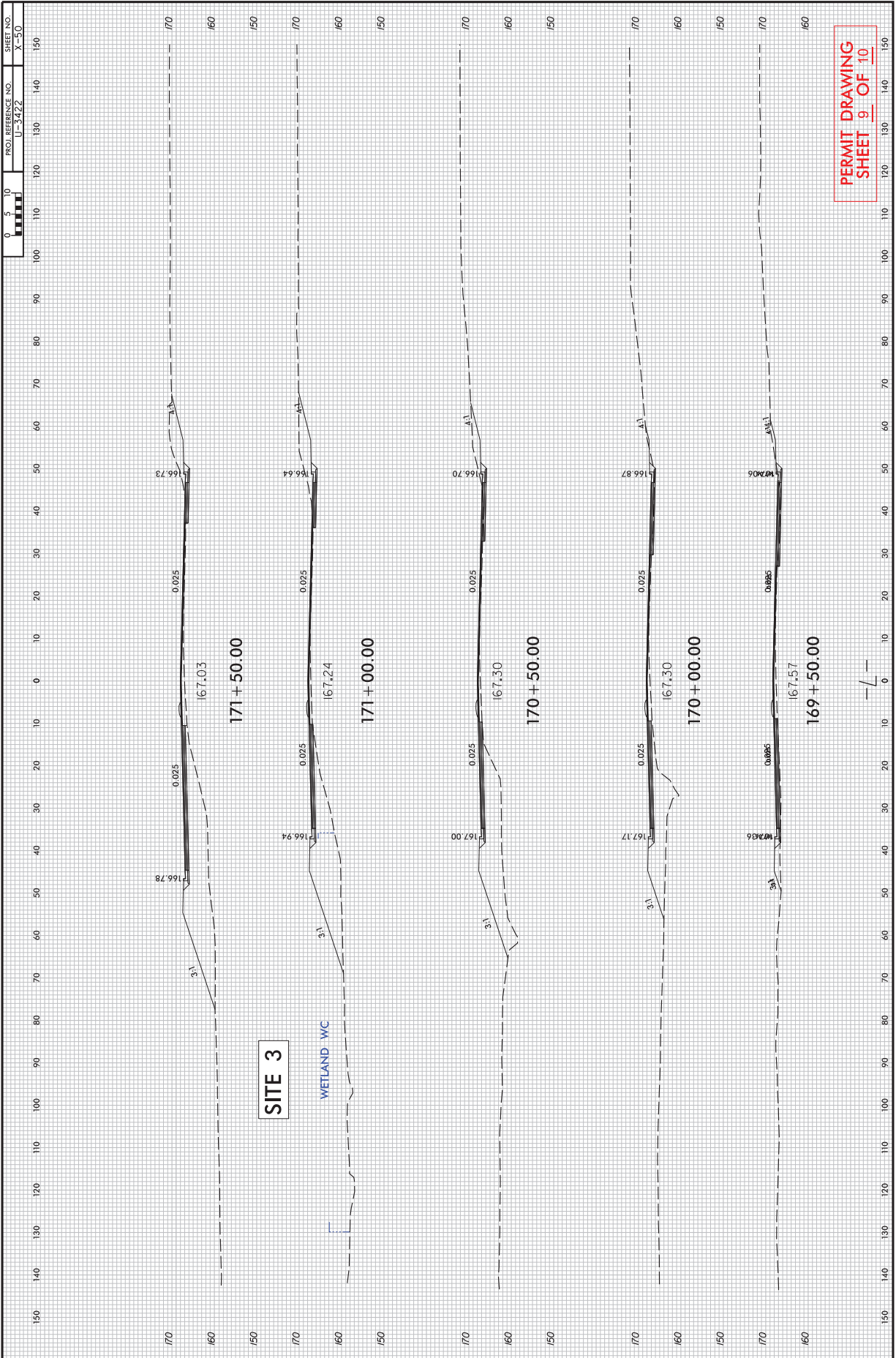

PLOT DRIVE: KCD01.pdfl,color=ang,100.dpi  
 USER: jusehmac DATE: 5/3/2023 TIME: 3:13:33 PM  
 FILE: 15422.dwg, PML,XPL,L.dwg  
 8/23/99



County: CUMBERLAND

Line #	Item Number	Sec #	Description	Quantity	Unit Cost	Amount
<b>ROADWAY ITEMS</b>						
0001	0000100000-N	800	MOBILIZATION	Lump Sum	L.S.	
0002	0000400000-N	801	CONSTRUCTION SURVEYING	Lump Sum	L.S.	
0003	0015000000-N	205	SEALING ABANDONED WELLS	3 EA		
0004	0043000000-N	226	GRADING	Lump Sum	L.S.	
0005	0050000000-E	226	SUPPLEMENTARY CLEARING & GRUBBING	1 ACR		
0006	0057000000-E	226	UNDERCUT EXCAVATION	100 CY		
0007	0134000000-E	240	DRAINAGE DITCH EXCAVATION	7,140 CY		
0008	0195000000-E	265	SELECT GRANULAR MATERIAL	100 CY		
0009	0196000000-E	270	GEOTEXTILE FOR SOIL STABILIZATION	1,000 SY		
0010	0199000000-E	SP	TEMPORARY SHORING	500 SF		
0011	0318000000-E	300	FOUNDATION CONDITIONING MATERIAL, MINOR STRUCTURES	1,540 TON		
0012	0321000000-E	300	FOUNDATION CONDITIONING GEOTEXTILE	4,820 SY		
0013	0344000000-E	310	18" SIDE DRAIN PIPE	124 LF		
0014	0366000000-E	310	15" RC PIPE CULVERTS, CLASS III	272 LF		
0015	0372000000-E	310	18" RC PIPE CULVERTS, CLASS III	232 LF		
0016	0378000000-E	310	24" RC PIPE CULVERTS, CLASS III	1,824 LF		
0017	0384000000-E	310	30" RC PIPE CULVERTS, CLASS III	280 LF		



County: CUMBERLAND

Line #	Item Number	Sec #	Description	Quantity	Unit Cost	Amount
0018	0390000000-E	310	36" RC PIPE CULVERTS, CLASS III	592 LF		
0019	0396000000-E	310	42" RC PIPE CULVERTS, CLASS III	344 LF		
0020	0402000000-E	310	48" RC PIPE CULVERTS, CLASS III	112 LF		
0021	0414000000-E	310	60" RC PIPE CULVERTS, CLASS III	48 LF		
0022	0448000000-E	310	***** RC PIPE CULVERTS, CLASS IV (54")	72 LF		
0023	0448200000-E	310	15" RC PIPE CULVERTS, CLASS IV	4,544 LF		
0024	0448300000-E	310	18" RC PIPE CULVERTS, CLASS IV	4,128 LF		
0025	0448400000-E	310	24" RC PIPE CULVERTS, CLASS IV	1,684 LF		
0026	0448500000-E	310	30" RC PIPE CULVERTS, CLASS IV	192 LF		
0027	0582000000-E	310	15" CS PIPE CULVERTS, 0.064" THICK	8 LF		
0028	0636000000-E	310	*** CS PIPE ELBOWS, ***** THICK (15", 0.064")	2 EA		
0029	0995000000-E	340	PIPE REMOVAL	1,340 LF		
0030	1099500000-E	505	SHALLOW UNDERCUT	1,250 CY		
0031	1099700000-E	505	CLASS IV SUBGRADE STABILIZATION	2,500 TON		
0032	1110000000-E	510	STABILIZER AGGREGATE	250 TON		
0033	1112000000-E	505	GEOTEXTILE FOR SUBGRADE STABILIZATION	3,750 SY		
0034	1220000000-E	545	INCIDENTAL STONE BASE	700 TON		

County: CUMBERLAND

Line #	Item Number	Sec #	Description	Quantity	Unit Cost	Amount
0035	1297000000-E	607	MILLING ASPHALT PAVEMENT, **** DEPTH (1-1/2")	600 SY		
0036	1308000000-E	607	MILLING ASPHALT PAVEMENT, **** TO ***** (0" TO 1-1/2")	2,800 SY		
0037	1330000000-E	607	INCIDENTAL MILLING	1,800 SY		
0038	1491000000-E	610	ASPHALT CONC BASE COURSE, TYPE B25.0C	15,830 TON		
0039	1503000000-E	610	ASPHALT CONC INTERMEDIATE COURSE, TYPE I19.0C	12,500 TON		
0040	1519000000-E	610	ASPHALT CONC SURFACE COURSE, TYPE S9.5B	500 TON		
0041	1523000000-E	610	ASPHALT CONC SURFACE COURSE, TYPE S9.5C	12,280 TON		
0042	1575000000-E	620	ASPHALT BINDER FOR PLANT MIX	2,070 TON		
0043	1693000000-E	654	ASPHALT PLANT MIX, PAVEMENT REPAIR	1,660 TON		
0044	2022000000-E	815	SUBDRAIN EXCAVATION	1,680 CY		
0045	2026000000-E	815	GEOTEXTILE FOR SUBSURFACE DRAINS	10,000 SY		
0046	2036000000-E	815	SUBDRAIN COARSE AGGREGATE	1,680 CY		
0047	2044000000-E	815	6" PERFORATED SUBDRAIN PIPE	10,000 LF		
0048	2070000000-N	815	SUBDRAIN PIPE OUTLET	20 EA		
0049	2077000000-E	815	6" OUTLET PIPE	120 LF		
0050	2209000000-E	838	ENDWALLS	10.5 CY		
0051	2286000000-N	840	MASONRY DRAINAGE STRUCTURES	146 EA		

County: CUMBERLAND

Line #	Item Number	Sec #	Description	Quantity	Unit Cost	Amount
0052	2297000000-E	840	MASONRY DRAINAGE STRUCTURES	10 CY		
0053	2308000000-E	840	MASONRY DRAINAGE STRUCTURES	64.4 LF		
0054	2364000000-N	840	FRAME WITH TWO GRATES, STD 840.16	48 EA		
0055	2366000000-N	840	FRAME WITH TWO GRATES, STD 840.24	2 EA		
0056	2374000000-N	840	FRAME WITH GRATE & HOOD, STD 840.03, TYPE ** (E)	19 EA		
0057	2374000000-N	840	FRAME WITH GRATE & HOOD, STD 840.03, TYPE ** (F)	38 EA		
0058	2374000000-N	840	FRAME WITH GRATE & HOOD, STD 840.03, TYPE ** (G)	38 EA		
0059	2396000000-N	840	FRAME WITH COVER, STD 840.54	1 EA		
0060	2451000000-N	852	CONCRETE TRANSITIONAL SECTION FOR DROP INLET	26 EA		
0061	2535000000-E	846	*** X *** CONCRETE CURB (8" X 18")	120 LF		
0062	2542000000-E	846	1'-6" CONCRETE CURB & GUTTER	7,600 LF		
0063	2549000000-E	846	2'-6" CONCRETE CURB & GUTTER	14,500 LF		
0064	2591000000-E	848	4" CONCRETE SIDEWALK	1,233 SY		
0065	2605000000-N	848	CONCRETE CURB RAMPS	5 EA		
0066	2612000000-E	848	6" CONCRETE DRIVEWAY	720 SY		
0067	2612500000-N	848	REMOVE AND REPLACE CONCRETE CURB RAMPS	1 EA		
0068	2655000000-E	852	5" MONOLITHIC CONCRETE ISLANDS (KEYED IN)	1,900 SY		

County: CUMBERLAND

Line #	Item Number	Sec #	Description	Quantity	Unit Cost	Amount
0069	2830000000-N	858	ADJUSTMENT OF MANHOLES	4 EA		
0070	2860000000-N	859	CONVERT EXISTING CATCH BASIN TO JUNCTION BOX	1 EA		
0071	3030000000-E	862	STEEL BEAM GUARDRAIL	250 LF		
0072	3150000000-N	862	ADDITIONAL GUARDRAIL POSTS	5 EA		
0073	3210000000-N	862	GUARDRAIL END UNITS, TYPE CAT-1	3 EA		
0074	3287000000-N	862	GUARDRAIL END UNITS, TYPE TL-3	3 EA		
0075	3628000000-E	876	RIP RAP, CLASS I	140 TON		
0076	3635000000-E	876	RIP RAP, CLASS II	220 TON		
0077	3649000000-E	876	RIP RAP, CLASS B	180 TON		
0078	3656000000-E	876	GEOTEXTILE FOR DRAINAGE	2,495 SY		
0079	4025000000-E	901	CONTRACTOR FURNISHED, TYPE *** SIGN (E)	446 SF		
0080	4072000000-E	903	SUPPORTS, 3-LB STEEL U-CHANNEL	916 LF		
0081	4102000000-N	904	SIGN ERECTION, TYPE E	67 EA		
0082	4155000000-N	907	DISPOSAL OF SIGN SYSTEM, U-CHANNEL	32 EA		
0083	4400000000-E	1110	WORK ZONE SIGNS (STATIONARY)	228 SF		
0084	4405000000-E	1110	WORK ZONE SIGNS (PORTABLE)	416 SF		
0085	4410000000-E	1110	WORK ZONE SIGNS (BARRICADE MOUNTED)	174 SF		

County: CUMBERLAND

Line #	Item Number	Sec #	Description	Quantity	Unit Cost	Amount
0086	4430000000-N	1130	DRUMS	490 EA		
0087	4435000000-N	1135	CONES	50 EA		
0088	4445000000-E	1145	BARRICADES (TYPE III)	72 LF		
0089	4447000000-E	SP	PEDESTRIAN CHANNELIZING DEVICES	32 LF		
0090	4455000000-N	1150	FLAGGER	120 DAY		
0091	4465000000-N	1160	TEMPORARY CRASH CUSHIONS	2 EA		
0092	4470000000-N	1160	REMOVE & RESET TEMPORARY CRASH CUSHION	2 EA		
0093	4490000000-E	1170	PORTABLE CONCRETE BARRIER (ANCHORED)	325 LF		
0094	4500000000-E	1170	REMOVE AND RESET PORTABLE CONCRETE BARRIER	196 LF		
0095	4510000000-N	1190	LAW ENFORCEMENT	42 HR		
0096	4516000000-N	1180	SKINNY DRUM	50 EA		
0097	4650000000-N	1251	TEMPORARY RAISED PAVEMENT MARKERS	576 EA		
0098	4685000000-E	1205	THERMOPLASTIC PAVEMENT MARKING LINES (4", 90 MILS)	24,428 LF		
0099	4695000000-E	1205	THERMOPLASTIC PAVEMENT MARKING LINES (8", 90 MILS)	2,219 LF		
0100	4700000000-E	1205	THERMOPLASTIC PAVEMENT MARKING LINES (12", 90 MILS)	525 LF		
0101	4709000000-E	1205	THERMOPLASTIC PAVEMENT MARKING LINES (24", 90 MILS)	593 LF		
0102	4720000000-E	1205	THERMOPLASTIC PAVEMENT MARKING CHARACTER (90 MILS)	20 EA		

County: CUMBERLAND

Line #	Item Number	Sec #	Description	Quantity	Unit Cost	Amount
0103	4725000000-E	1205	THERMOPLASTIC PAVEMENT MARKING SYMBOL (90 MILS)	72 EA		
0104	4810000000-E	1205	PAINT PAVEMENT MARKING LINES (4")	74,453 LF		
0105	4820000000-E	1205	PAINT PAVEMENT MARKING LINES (8")	460 LF		
0106	4835000000-E	1205	PAINT PAVEMENT MARKING LINES (24")	220 LF		
0107	4845000000-N	1205	PAINT PAVEMENT MARKING SYMBOL	48 EA		
0108	4850000000-E	1205	REMOVAL OF PAVEMENT MARKING LINES (4")	4,925 LF		
0109	4860000000-E	1205	REMOVAL OF PAVEMENT MARKING LINES (8")	71 LF		
0110	4870000000-E	1205	REMOVAL OF PAVEMENT MARKING LINES (24")	58 LF		
0111	5325200000-E	1510	2" WATER LINE	22 LF		
0112	5325800000-E	1510	8" WATER LINE	5,186 LF		
0113	5326200000-E	1510	12" WATER LINE	8,816 LF		
0114	5329000000-E	1510	DUCTILE IRON WATER PIPE FITTINGS	49,281 LB		
0115	5536000000-E	1515	2" VALVE	2 EA		
0116	5540000000-E	1515	6" VALVE	12 EA		
0117	5546000000-E	1515	8" VALVE	22 EA		
0118	5558000000-E	1515	12" VALVE	16 EA		
0119	5589200000-E	1515	2" AIR RELEASE VALVE	8 EA		

County: CUMBERLAND

Line #	Item Number	Sec #	Description	Quantity	Unit Cost	Amount
0120	5606000000-E	1515	2" BLOW OFF	7 EA		
0121	5643000000-E	1515	*** WATER METER (1")	13 EA		
0122	5649000000-N	1515	RECONNECT WATER METER	1 EA		
0123	5666000000-N	1515	FIRE HYDRANT	10 EA		
0124	5673000000-E	1515	FIRE HYDRANT LEG	140 LF		
0125	5686000000-E	1515	*** WATER SERVICE LINE (1")	130 LF		
0126	5686000000-E	1515	*** WATER SERVICE LINE (2")	51 LF		
0127	5691300000-E	1520	8" SANITARY GRAVITY SEWER	308 LF		
0128	5709300000-E	1520	6" FORCE MAIN SEWER	1,304 LF		
0129	5709600000-E	1520	12" FORCE MAIN SEWER	232 LF		
0130	5768000000-N	1520	SANITARY SEWER CLEAN-OUT	1 EA		
0131	5768500000-E	1520	SEWER SERVICE LINE	41 LF		
0132	5769000000-E	1520	DUCTILE IRON SEWER PIPE FITTINGS	4,151 LB		
0133	5775000000-E	1525	4' DIA UTILITY MANHOLE	3 EA		
0134	5798000000-E	1530	ABANDON *** UTILITY PIPE (1")	191 LF		
0135	5800000000-E	1530	ABANDON 6" UTILITY PIPE	1,289 LF		
0136	5801000000-E	1530	ABANDON 8" UTILITY PIPE	1,449 LF		

County: CUMBERLAND

Line #	Item Number	Sec #	Description	Quantity	Unit Cost	Amount
0137	5804000000-E	1530	ABANDON 12" UTILITY PIPE	8,951 LF		
0138	5815000000-N	1530	REMOVE WATER METER	3 EA		
0139	5815500000-N	1530	REMOVE FIRE HYDRANT	10 EA		
0140	5828000000-N	1530	REMOVE UTILITY MANHOLE	1 EA		
0141	5835700000-E	1540	16" ENCASEMENT PIPE	442 LF		
0142	5836000000-E	1540	24" ENCASEMENT PIPE	228 LF		
0143	5872500000-E	1550	BORE AND JACK OF *** (16")	332 LF		
0144	5872600000-E	1550	DIRECTIONAL DRILLING OF *** (12")	415 LF		
0145	6000000000-E	1605	TEMPORARY SILT FENCE	22,950 LF		
0146	6006000000-E	1610	STONE FOR EROSION CONTROL, CLASS A	930 TON		
0147	6009000000-E	1610	STONE FOR EROSION CONTROL, CLASS B	2,225 TON		
0148	6012000000-E	1610	SEDIMENT CONTROL STONE	2,080 TON		
0149	6015000000-E	1615	TEMPORARY MULCHING	41.5 ACR		
0150	6018000000-E	1620	SEED FOR TEMPORARY SEEDING	2,400 LB		
0151	6021000000-E	1620	FERTILIZER FOR TEMPORARY SEEDING	12.5 TON		
0152	6024000000-E	1622	TEMPORARY SLOPE DRAINS	400 LF		
0153	6029000000-E	SP	SAFETY FENCE	1,200 LF		



County: CUMBERLAND

Line #	Item Number	Sec #	Description	Quantity	Unit Cost	Amount
0154	6030000000-E	1630	SILT EXCAVATION	9,100 CY		
0155	6036000000-E	1631	MATTING FOR EROSION CONTROL	14,600 SY		
0156	6037000000-E	1629	COIR FIBER MAT	100 SY		
0157	6042000000-E	1632	1/4" HARDWARE CLOTH	4,700 LF		
0158	6043000000-E	1644	LOW PERMEABILITY GEOTEXTILE	900 SY		
0159	6048000000-E	SP	FLOATING TURBIDITY CURTAIN	200 SY		
0160	6070000000-N	1639	SPECIAL STILLING BASINS	5 EA		
0161	6071002000-E	1642	FLOCCULANT	215 LB		
0162	6071012000-E	1642	COIR FIBER WATTLE	1,890 LF		
0163	6071030000-E	1640	COIR FIBER BAFFLE	1,255 LF		
0164	6071050000-E	1644	*** SKIMMER (1-1/2")	5 EA		
0165	6071050000-E	1644	*** SKIMMER (2")	3 EA		
0166	6071050000-E	1644	*** SKIMMER (3")	1 EA		
0167	6084000000-E	1660	SEEDING & MULCHING	40 ACR		
0168	6087000000-E	1660	MOWING	20 ACR		
0169	6090000000-E	1661	SEED FOR REPAIR SEEDING	450 LB		
0170	6093000000-E	1661	FERTILIZER FOR REPAIR SEEDING	1.25 TON		

County: CUMBERLAND

Line #	Item Number	Sec #	Description	Quantity	Unit Cost	Amount
0171	6096000000-E	1662	SEED FOR SUPPLEMENTAL SEEDING	755 LB		
0172	6108000000-E	1665	FERTILIZER TOPDRESSING	23.25 TON		
0173	6111000000-E	SP	IMPERVIOUS DIKE	275 LF		
0174	6114500000-N	1667	SPECIALIZED HAND MOWING	10 MHR		
0175	6117000000-N	1675	RESPONSE FOR EROSION CONTROL	50 EA		
0176	6117500000-N	SP	CONCRETE WASHOUT STRUCTURE	10 EA		
0177	6132000000-N	SP	GENERIC EROSION CONTROL ITEM FABRIC INSERT INLET PROTECTION CLEANOUT	105 EA		
0178	6132000000-N	SP	GENERIC EROSION CONTROL ITEM FABRIC INSERT INLET PROTECTION, TYPE 1	35 EA		
0179	7048500000-E	1705	PEDESTRIAN SIGNAL HEAD (16", 1 SECTION W/COUNTDOWN)	4 EA		
0180	7060000000-E	1705	SIGNAL CABLE	5,490 LF		
0181	7120000000-E	1705	VEHICLE SIGNAL HEAD (12", 3 SECTION)	17 EA		
0182	7132000000-E	1705	VEHICLE SIGNAL HEAD (12", 4 SECTION)	9 EA		
0183	7252000000-E	1710	MESSENGER CABLE (1/4")	9,495 LF		
0184	7264000000-E	1710	MESSENGER CABLE (3/8")	1,060 LF		
0185	7288000000-E	1715	PAVED TRENCHING (***** (2, 2")	40 LF		
0186	7300000000-E	1715	UNPAVED TRENCHING (***** (2, 2")	30 LF		
0187	7300000000-E	1715	UNPAVED TRENCHING (***** (4, 2")	70 LF		

County: CUMBERLAND

Line #	Item Number	Sec #	Description	Quantity	Unit Cost	Amount
0188	7300000000-E	1715	UNPAVED TRENCHING (*****) (6, 2")	20 LF		
0189	7324000000-N	1716	JUNCTION BOX (STANDARD SIZE)	3 EA		
0190	7348000000-N	1716	JUNCTION BOX (OVER-SIZED, HEAVY DUTY)	3 EA		
0191	7360000000-N	1720	WOOD POLE	2 EA		
0192	7372000000-N	1721	GUY ASSEMBLY	25 EA		
0193	7396000000-E	1722	1/2" RISER WITH WEATHERHEAD	1 EA		
0194	7408000000-E	1722	1" RISER WITH WEATHERHEAD	1 EA		
0195	7420000000-E	1722	2" RISER WITH WEATHERHEAD	3 EA		
0196	7432000000-E	1722	2" RISER WITH HEAT SHRINK TUBING	1 EA		
0197	7456100000-E	1726	LEAD-IN CABLE (14-2)	650 LF		
0198	7516000000-E	1730	COMMUNICATIONS CABLE (** FIBER) (24)	10,723 LF		
0199	7528000000-E	1730	DROP CABLE	616 LF		
0200	7540000000-N	1731	SPLICE ENCLOSURE	3 EA		
0201	7552000000-N	1731	INTERCONNECT CENTER	1 EA		
0202	7566000000-N	1733	DELINEATOR MARKER	1 EA		
0203	7575142000-N	1736	900MHZ SERIAL SPREAD SPECTRUM RADIO	5 EA		
0204	7575142060-N	1737	MODIFY RADIO INSTALLATION	1 EA		

County: CUMBERLAND

Line #	Item Number	Sec #	Description	Quantity	Unit Cost	Amount
0205	7576000000-N	SP	METAL STRAIN SIGNAL POLE	4 EA		
0206	7613000000-N	SP	SOIL TEST	4 EA		
0207	7614100000-E	SP	DRILLED PIER FOUNDATION	40 CY		
0208	7642200000-N	1743	TYPE II PEDESTAL WITH FOUNDATION	2 EA		
0209	7684000000-N	1750	SIGNAL CABINET FOUNDATION	1 EA		
0210	7696000000-N	1751	CONTROLLERS WITH CABINET (*****) (TYPE 2070LX CONTROLLER, BASE MOUNTED)	1 EA		
0211	7901000000-N	1753	CABINET BASE EXTENDER	1 EA		
0212	7980000000-N	SP	GENERIC SIGNAL ITEM 2070LX CONTROLLER WITHOUT CABINET	4 EA		
0213	7980000000-N	SP	GENERIC SIGNAL ITEM ETHERNET EDGE SWITCH	5 EA		
0214	7980000000-N	SP	GENERIC SIGNAL ITEM MICROWAVE VEHICLE DETECTION SYSTEM - MULTIPLE ZONES	6 EA		

County: CUMBERLAND

Line #	Item Number	Sec #	Description	Quantity	Unit Cost	Amount
***** BEGIN SCHEDULE AA ***** ***** ( 5 ALTERNATES ) *****						
0215 AA1	4894900000-E	SP	GENERIC PAVEMENT MARKING ITEM 10' INLAID PAVEMENT MARKINGS	459 EA		
*** OR ***						
0216 AA2	4894900000-E	SP	GENERIC PAVEMENT MARKING ITEM 10' RUMBLE STRIPS	459 EA		
*** OR ***						
0217 AA3	4895000000-N	SP	GENERIC PAVEMENT MARKING ITEM INLAID CRADLE MARKERS	459 EA		
*** OR ***						
0218 AA4	4895000000-N	SP	GENERIC PAVEMENT MARKING ITEM INLAID RAISED PAVEMENT MARKINGS	459 EA		
*** OR ***						
0219 AA5	4895000000-N	SP	GENERIC PAVEMENT MARKING ITEM POLYCARBONATE H-SHAPED MARKERS	459 EA		
***** END SCHEDULE AA *****						
<b>WALL ITEMS</b>						
0220	8802030000-E	454	SEGMENTAL GRAVITY RETAINING WALLS	390 SF		

1018/Nov07/Q436188.4/D967003208060/E220

Total Amount Of Bid For Entire Project :