

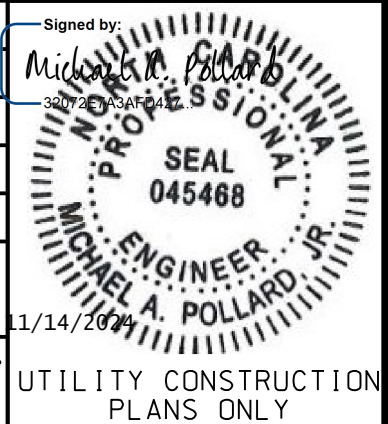

CDM Smith Inc. 5400 Glenwood Avenue Suite 400 Raleigh, NC 27612-3228 NC COA No. F-1255

PROJECT REFERENCE NO. U-3422 SHEET NO. UC-03C DESIGNED BY: SSM DRAWN BY: SSM CHECKED BY: HMH APPROVED BY: MAP

DOCUMENT NOT CONSIDERED FINAL UNLESS ALL SIGNATURES COMPLETED



UTILITY CONSTRUCTION

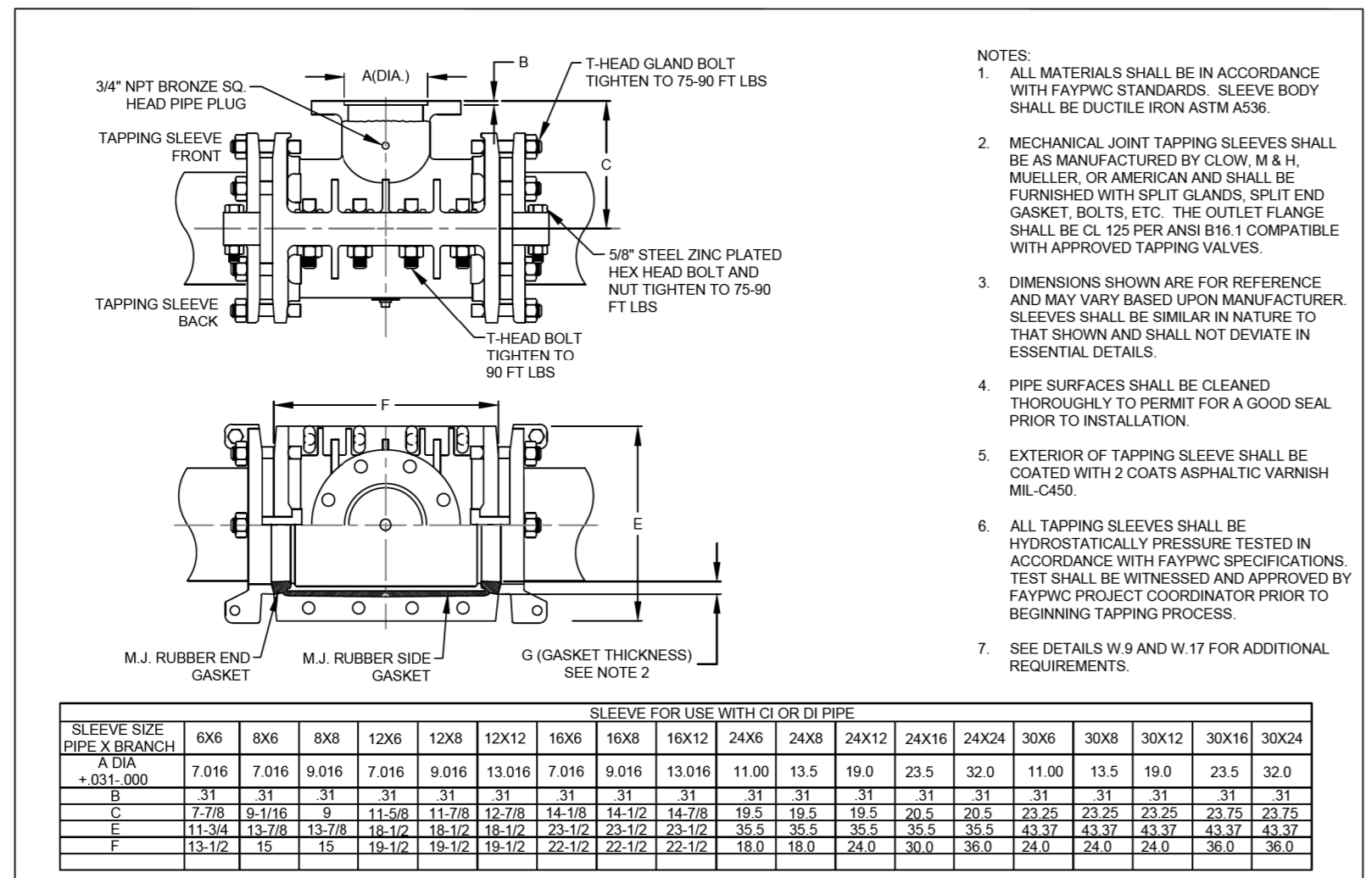

- NOTES: 1. ALL MATERIALS SHALL BE IN ACCORDANCE WITH FAYFWC STANDARDS... 2. MECHANICAL JOINT TAPPING SLEEVES SHALL BE AS MANUFACTURED BY GLOW, M & H...

Table with columns for SLEEVE SIZE, DWG NO. W.10, DATE: JULY 01, 2024, and APPROVED BY: M.M.M.

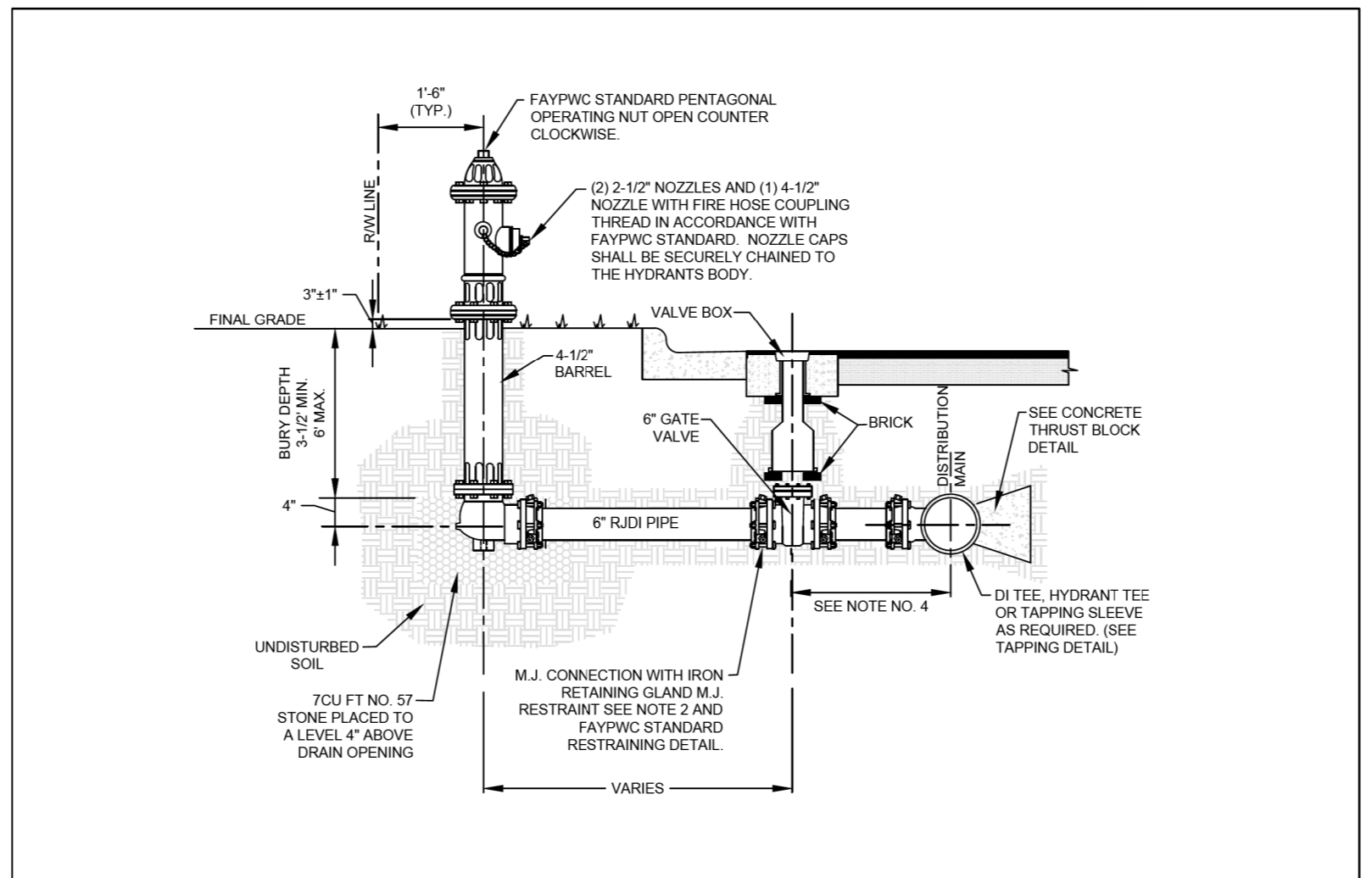

Table with columns for DWG NO. W.13, DATE: JULY 01, 2024, and APPROVED BY: M.M.M.

NOTE: ANY REFERENCE TO FAYFWC PROJECT COORDINATOR, PWC COORDINATOR OR FAYFWC (FAYETTEVILLE PUBLIC WORKS COMMISSION) SHALL BE INTERPRETTED AS A REFERENCE TO THE ENGINEER.

REVISIONS

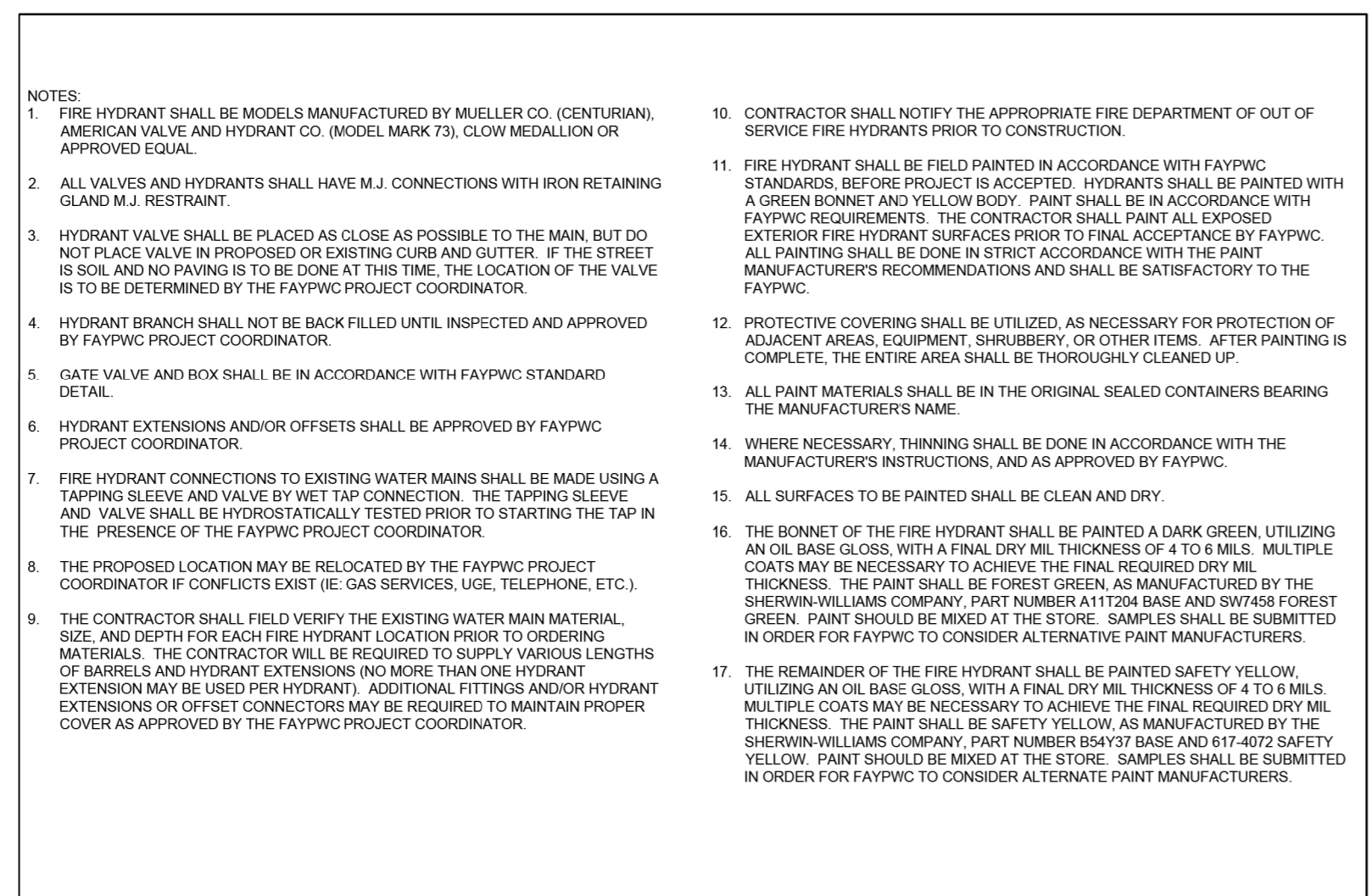

Table with columns for DWG NO. W.13, DATE: JULY 01, 2024, and APPROVED BY: M.M.M.

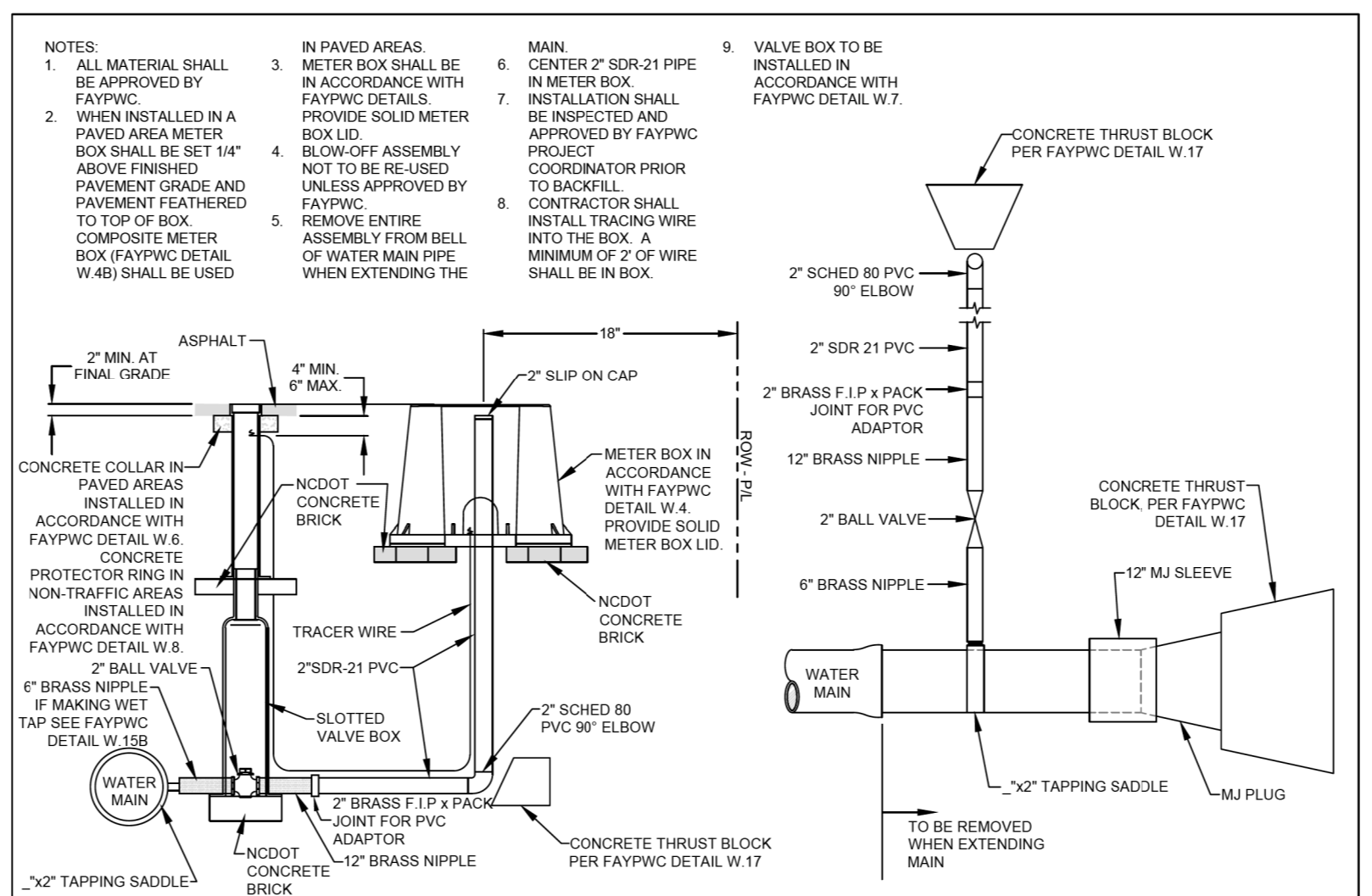

Table with columns for DWG NO. W.15, DATE: JULY 01, 2024, and APPROVED BY: M.M.M.

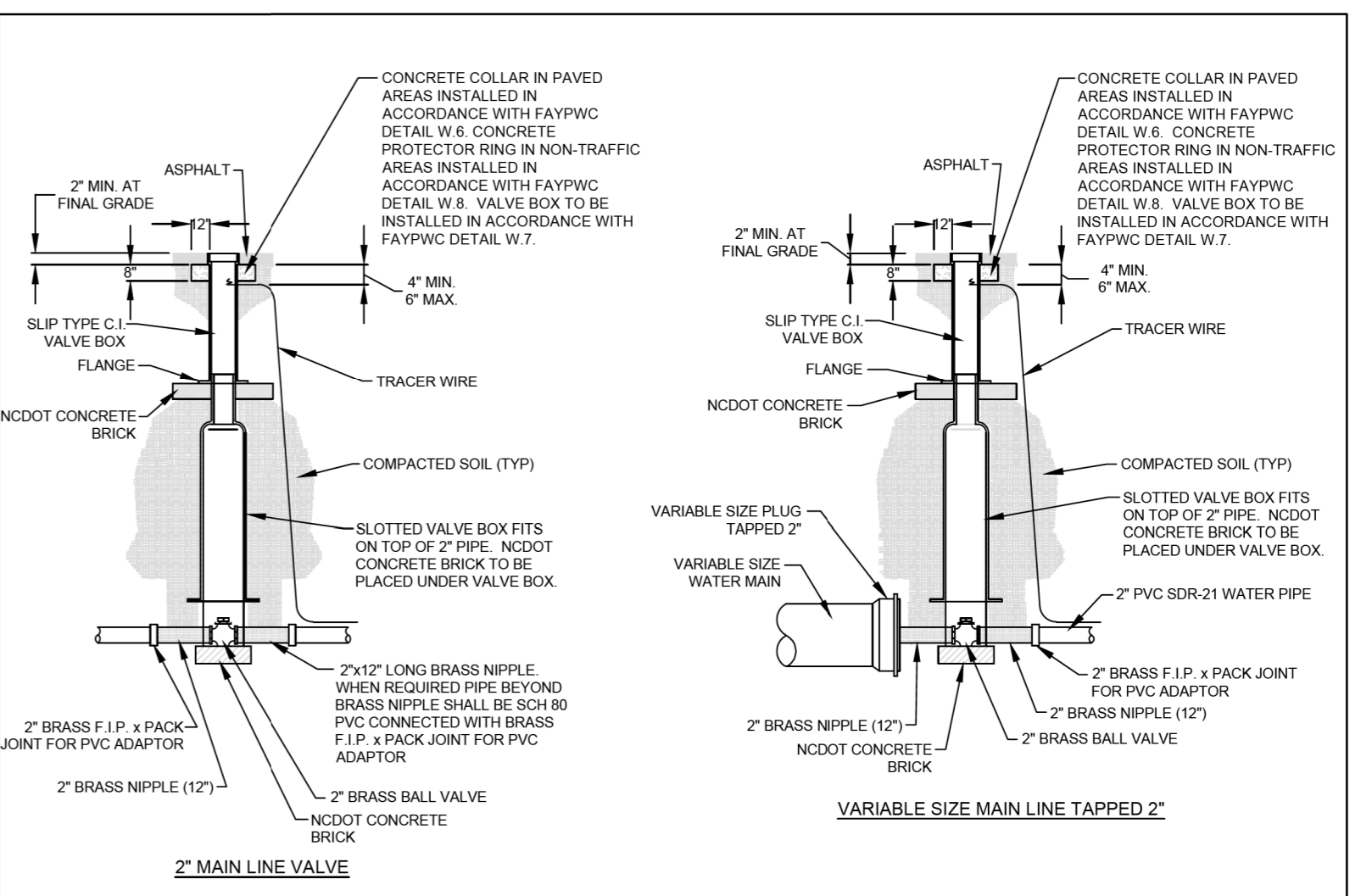

Table with columns for DWG NO. W.15A, DATE: JULY 01, 2024, and APPROVED BY: M.M.M.

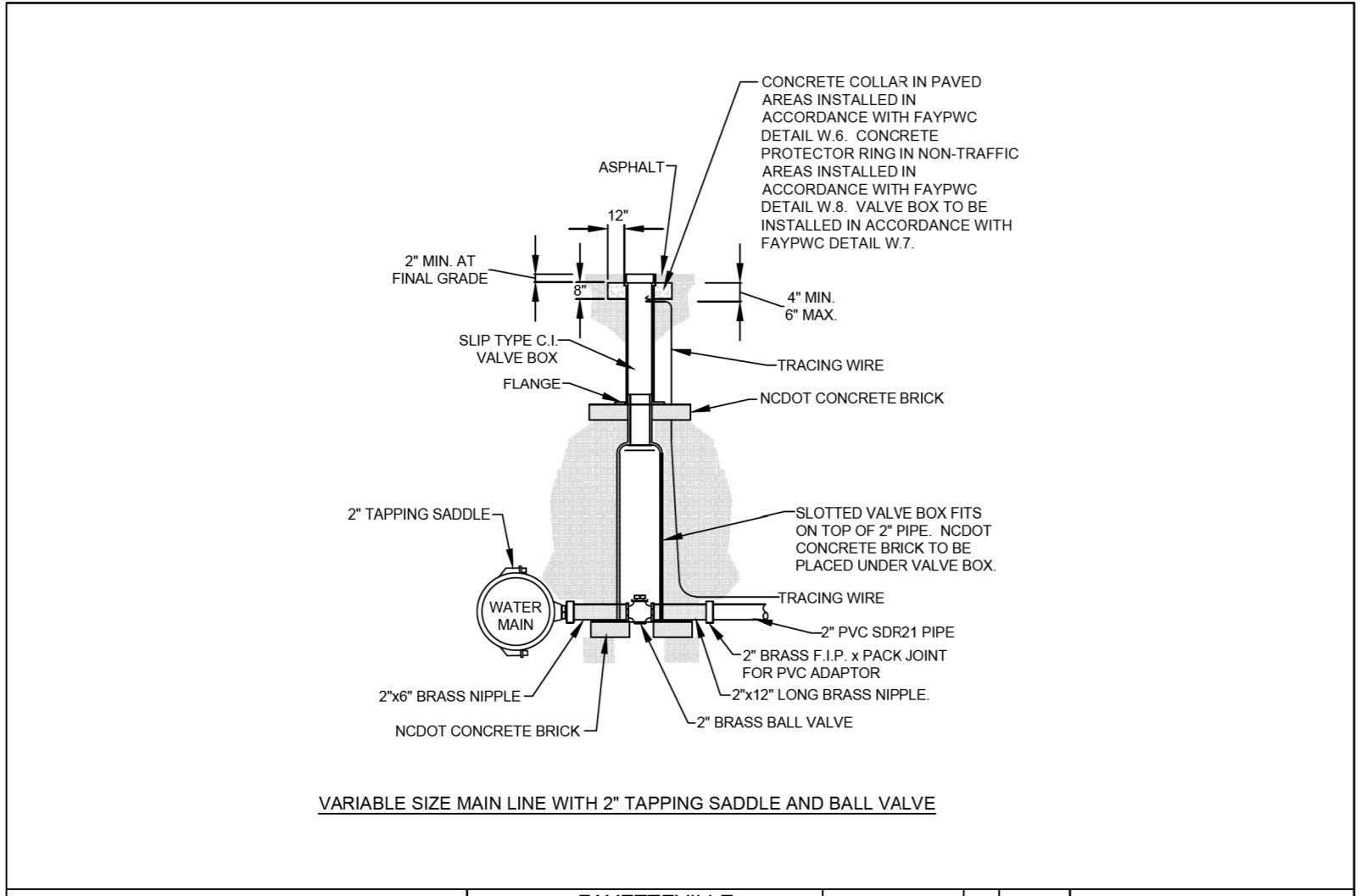

Table with columns for DWG NO. W.15B, DATE: JULY 01, 2024, and APPROVED BY: M.M.M.

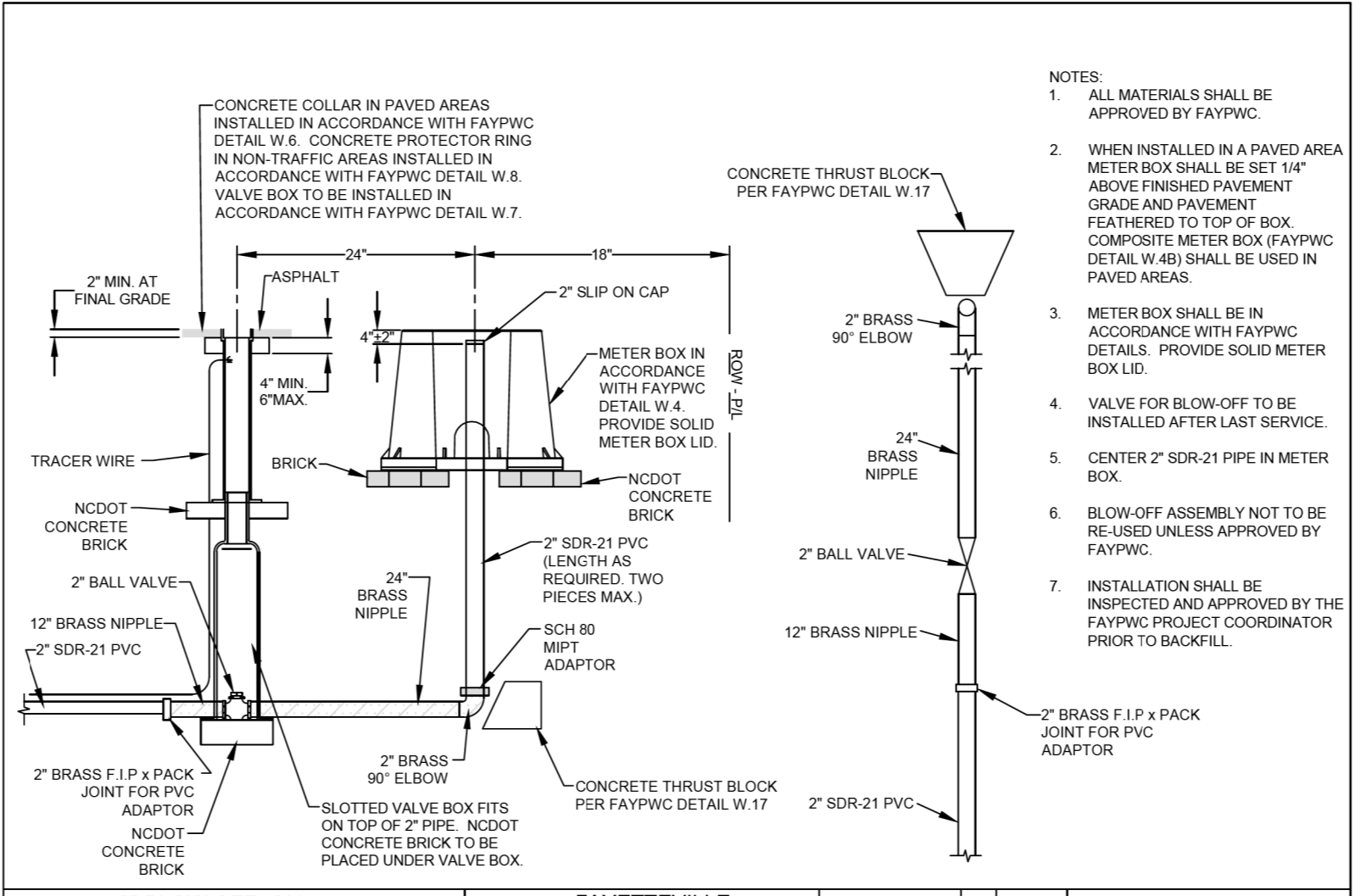

Table with columns for DWG NO. W.15C, DATE: JULY 01, 2024, and APPROVED BY: M.M.M.

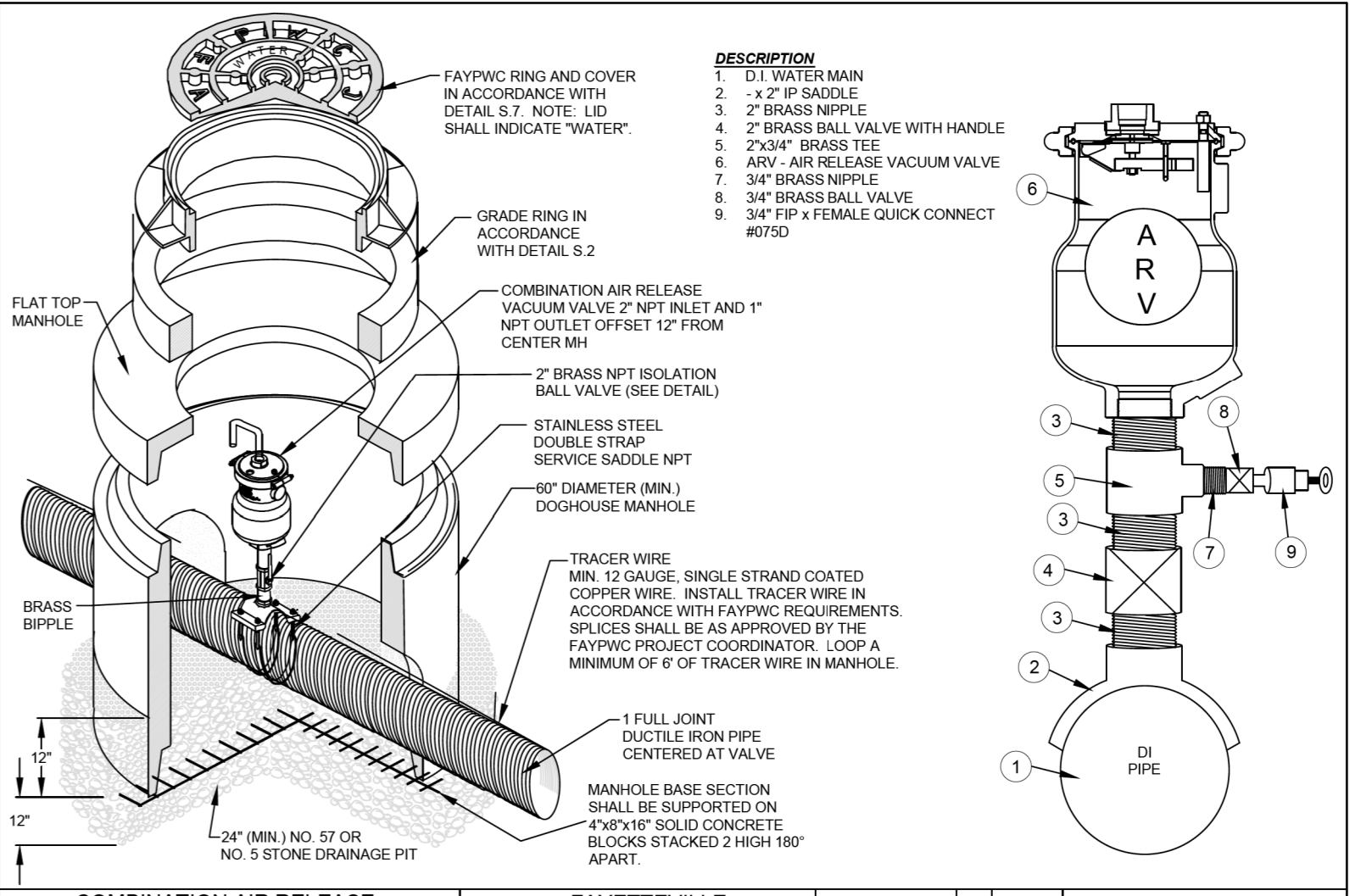

Table with columns for DWG NO. W.16, DATE: JULY 01, 2024, and APPROVED BY: M.M.M.

SYSTEM: 2024.07.01, USER: M.M.M.