

NOTE: PLACE TEMPORARY ROCK SEDIMENT DAMS TYPE - B AND TEMPORARY ROCK SILT CHECKS TYPE - A AT DRAINAGE OUTLETS.

-L-			
PI Sta 22+20.05 Δ = 25' 03" 06.3" (LT) D = 22' 55" 05.9" L = 109.31' T = 55.54' R = 250.00' R.O. = SEE PLANS SE = 0.04 V = 30 mph	PI Sta 24+04.92 Δ = 78' 39" 33.1" (LT) D = 35' 48" 35.5" L = 219.66' T = 131.0' R = 160.00' R.O. = SEE PLANS SE = 0.04 V = 25 mph	PI Sta 25+44.94 Δ = 37' 52" 24.5" (LT) D = 38' 11" 49.9" L = 99.15' T = 51.46' R = 150.00' R.O. = SEE PLANS SE = 0.04 V = 25 mph	PI Sta 26+96.20 Δ = 52' 17" 47.1" (LT) D = 35' 48" 35.5" L = 146.04' T = 78.55' R = 160.00'

-Y-		-Y2-		-LPC-	
PI Sta 13+58.32 Δ = 7' 00" 57.1" (LT) D = 1' 30" 28.0" L = 465.31' T = 232.95' R = 3,800.00'	PI Sta 18+08.02 Δ = 6' 43" 45.3" (LT) D = 1' 35" 29.6" L = 422.81' T = 211.65' R = 3,600.00'	PI Sta 10+89.79 Δ = 19' 03" 06.3" (RT) D = 55' 37" 37.1" L = 34.25' T = 17.28' R = 103.00'	PI Sta 12+23.69 Δ = 28' 21" 14.7" (RT) D = 44' 04" 25.2" L = 64.33' T = 32.84' R = 130.00' R.O. = SEE PLANS SE = 0.04 V = 20 mph	PI Sta 14+28.38 Δ = 116' 40" 08.1" (RT) D = 57' 17" 44.8" L = 203.63' T = 162.13' R = 100.00'	PI Sta 14+28.38 Δ = 116' 40" 08.1" (RT) D = 57' 17" 44.8" L = 203.63' T = 162.13' R = 100.00'

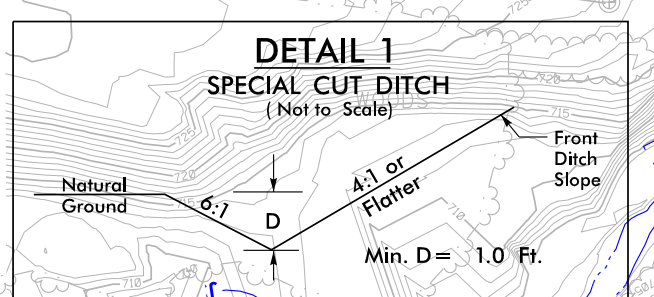
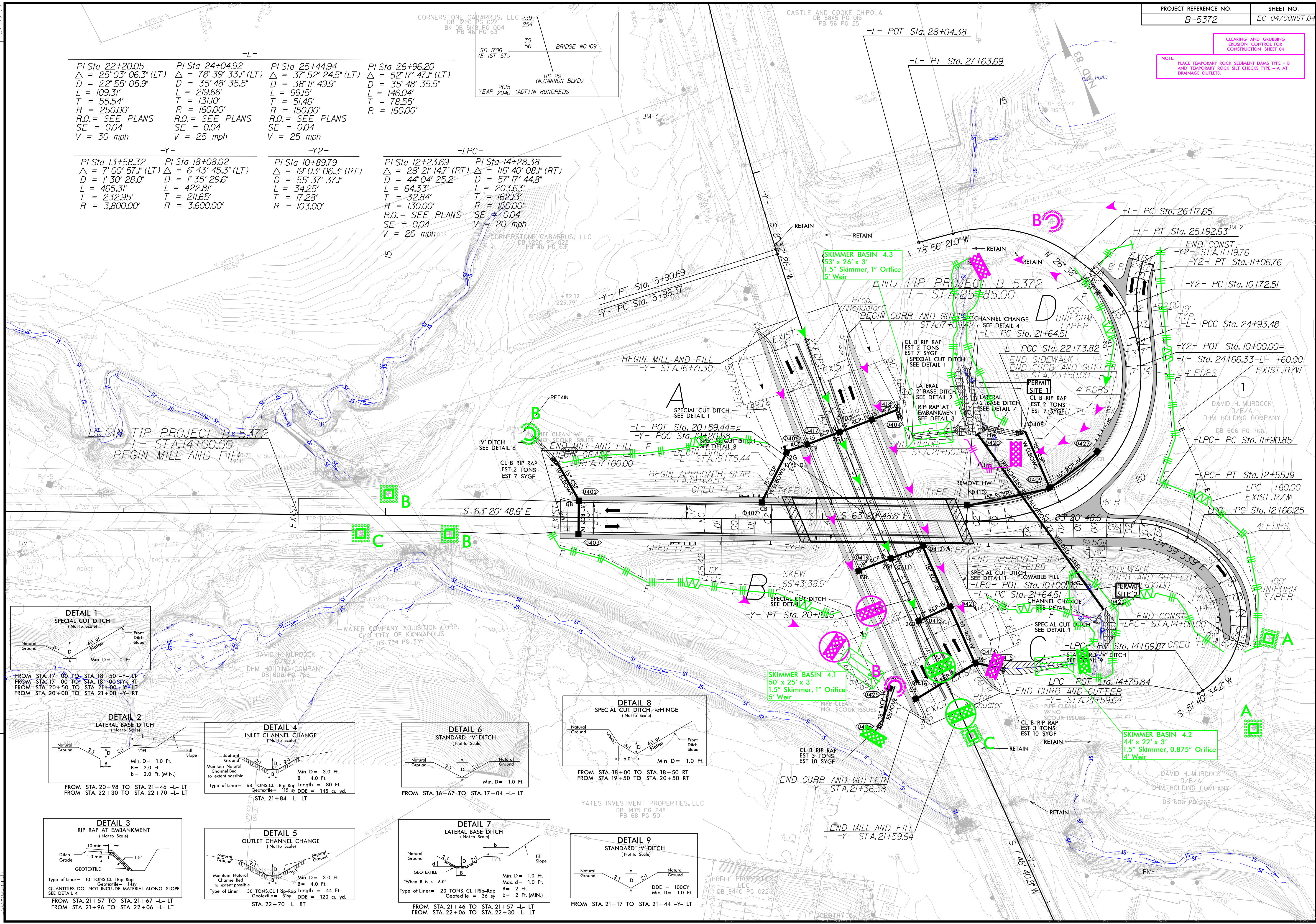
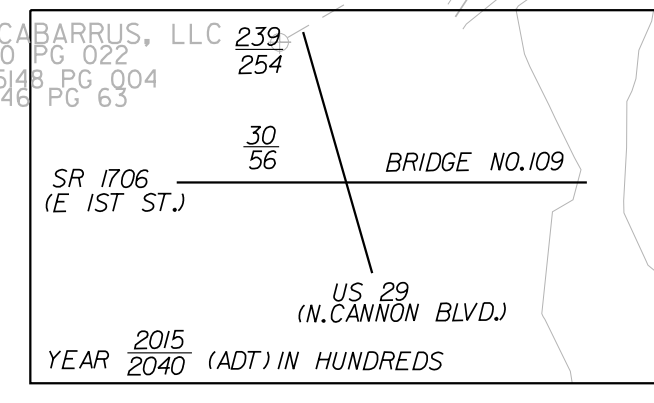

FROM STA. 17+00 TO STA. 18+50 -Y- LT
FROM STA. 17+00 TO STA. 18+00 -Y- RT
FROM STA. 20+00 TO STA. 21+00 -Y- LT
FROM STA. 20+00 TO STA. 21+00 -Y- RT

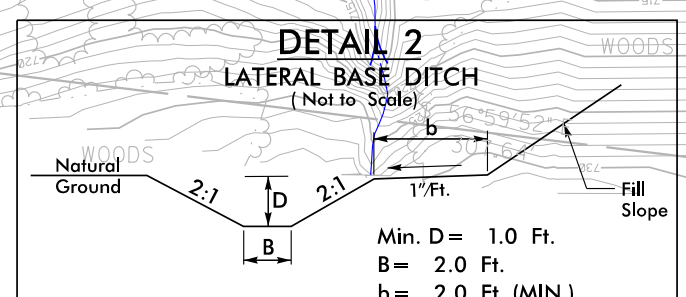

FROM STA. 20+98 TO STA. 21+46 -L- LT
FROM STA. 22+30 TO STA. 22+70 -L- LT

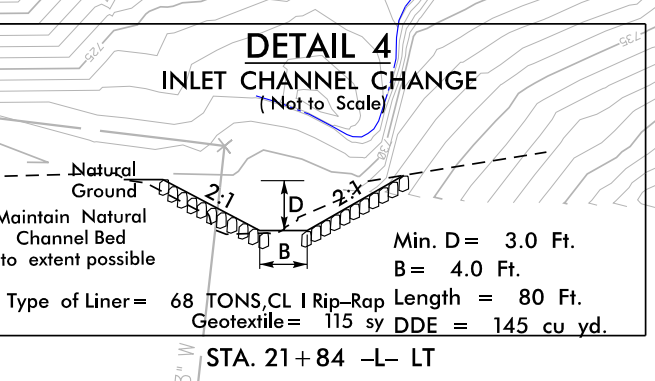

FROM STA. 21+84 -L- LT

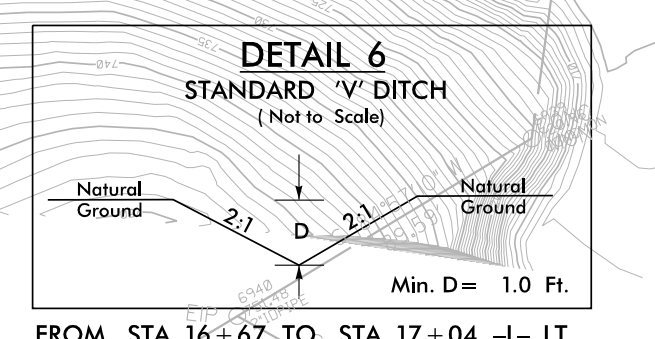

FROM STA. 16+67 TO STA. 17+04 -L- LT

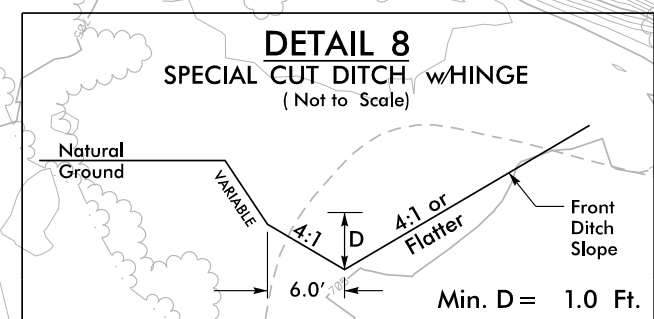

FROM STA. 18+00 TO STA. 18+50 RT
FROM STA. 19+50 TO STA. 20+50 RT

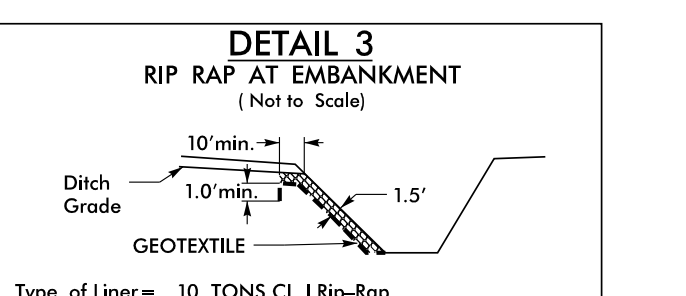

FROM STA. 21+57 TO STA. 21+67 -L- LT
FROM STA. 21+96 TO STA. 22+06 -L- LT

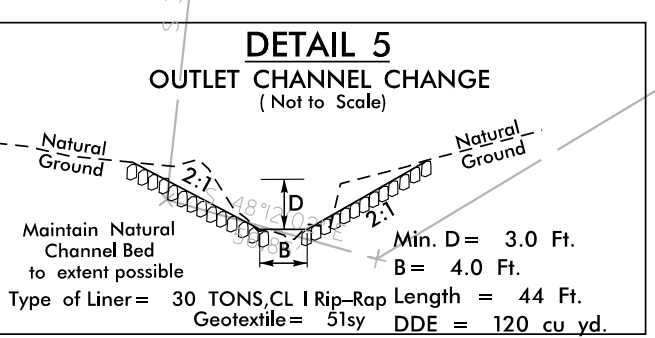

FROM STA. 22+70 -L- RT

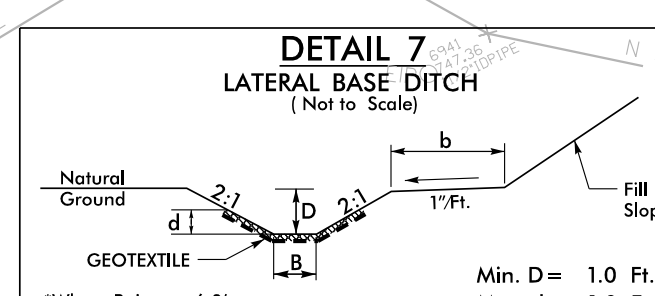

FROM STA. 21+46 TO STA. 21+57 -L- LT
FROM STA. 22+06 TO STA. 22+30 -L- LT

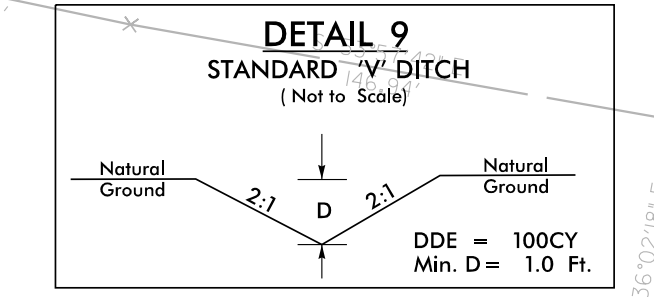

FROM STA. 21+17 TO STA. 21+44 -Y- LT

REVISIONS

5.30.2024 9:40:03 AM
B-5372 ENVIRONMENTAL