

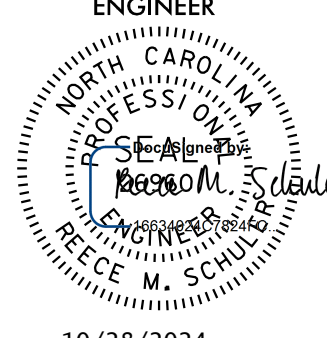

PROJECT REFERENCE NO. B-5372		SHEET NO. 4	
RW SHEET NO.		HYDRAULICS ENGINEER	
ROADWAY DESIGN ENGINEER		PROF. SEAL NO. 10000	
 RAYMOND S. SEDER PROF. SEAL NO. 10000 STATE OF NORTH CAROLINA 10/28/2024		 RAYMOND S. SEDER PROF. SEAL NO. 10000 STATE OF NORTH CAROLINA 10/28/2024	
PROJECT NOT CONSIDERED FINAL UNLESS ALL SIGNATURES COMPLETED			
 Johnson, Mirman, & Thompson, Inc. 2550 West Tryon Road, Suite 120, Charlotte, NC, 28217 License No: C-3097			

-L-			
PI Sta 22+20.05 Δ = 25' 03" 06.3" (LT) D = 22' 55" 05.9" L = 109.31' T = 55.54' R = 250.00' R.O. = SEE PLANS SE = 0.04 V = 30 mph	PI Sta 24+04.92 Δ = 78' 39" 33.1" (LT) D = 35' 48" 35.5" L = 219.66' T = 131.10' R = 160.00' R.O. = SEE PLANS SE = 0.04 V = 25 mph	PI Sta 25+44.94 Δ = 37' 52" 24.5" (LT) D = 38' 11" 49.9" L = 99.15' T = 51.46' R = 150.00' R.O. = SEE PLANS SE = 0.04 V = 25 mph	PI Sta 26+96.20 Δ = 52' 17" 47.1" (LT) D = 35' 48" 35.5" L = 146.04' T = 78.55' R = 160.00' R.O. = SEE PLANS SE = 0.04 V = 25 mph

-Y-		-LPC-	
PI Sta 13+58.32 Δ = 7' 00" 57.1" (LT) D = 1' 30" 28.0" L = 465.31' T = 232.95' R = 3,800.00'	PI Sta 18+08.02 Δ = 6' 43" 45.3" (LT) D = 1' 35" 29.6" L = 422.81' T = 211.65' R = 3,600.00'	PI Sta 10+89.79 Δ = 19' 03" 06.3" (RT) D = 55' 37" 37.1" L = 34.25' T = 17.28' R = 103.00'	PI Sta 12+23.69 Δ = 28' 21" 14.7" (RT) D = 44' 04" 25.2" L = 64.33' T = 32.84' R = 130.00' R.O. = SEE PLANS SE = 0.04 V = 20 mph

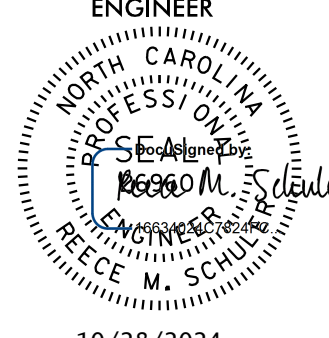

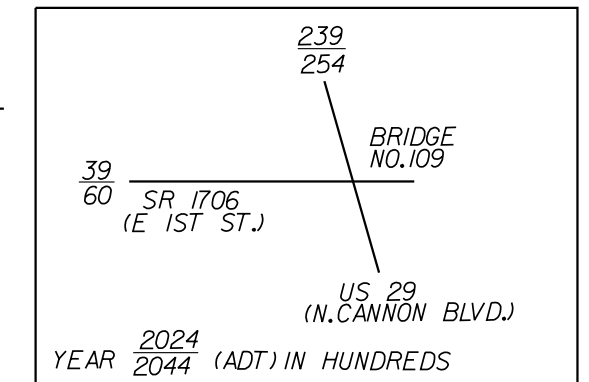
REVISIONS

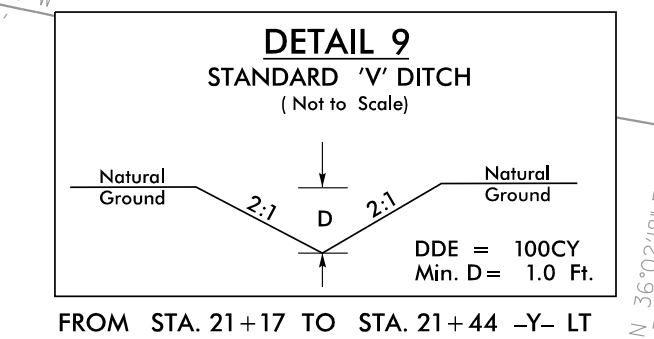
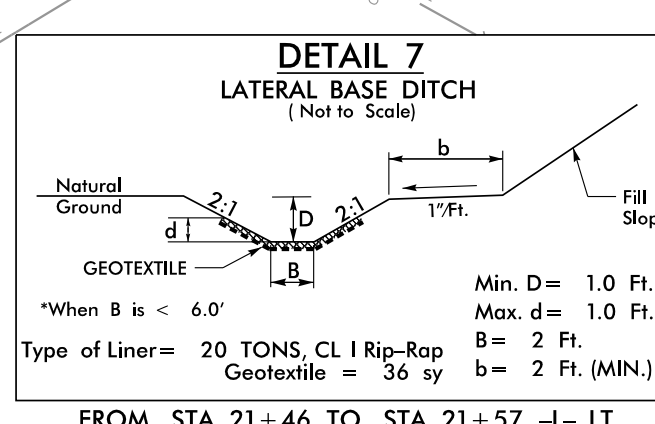
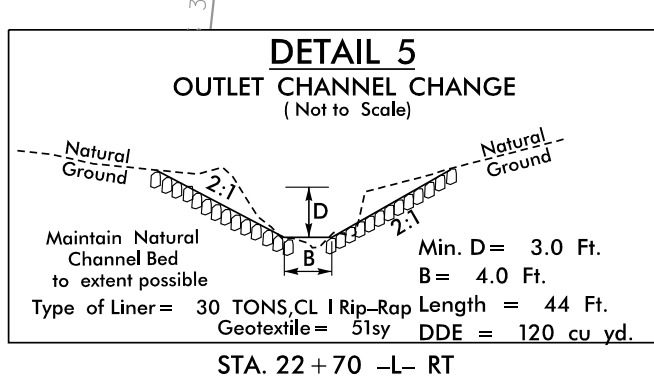
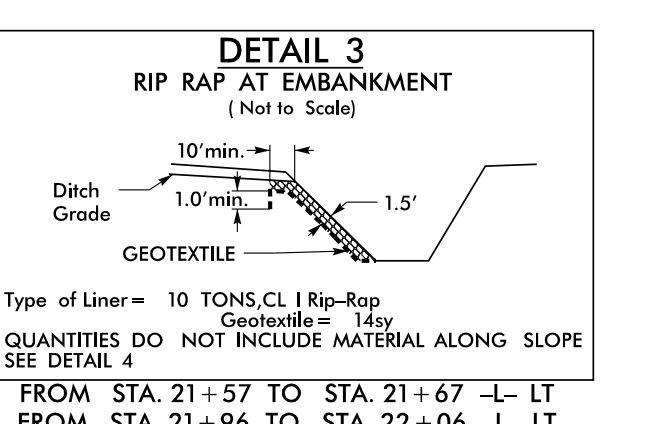
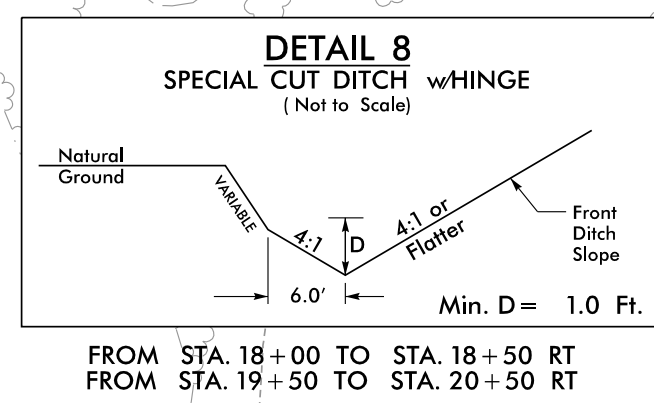
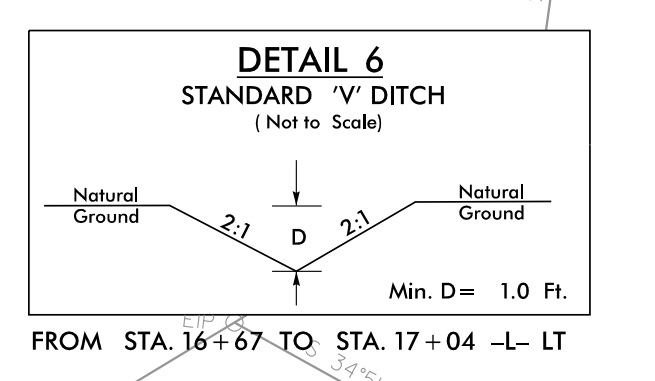
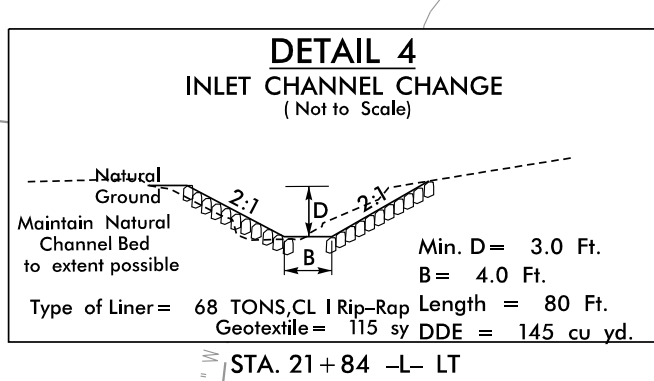
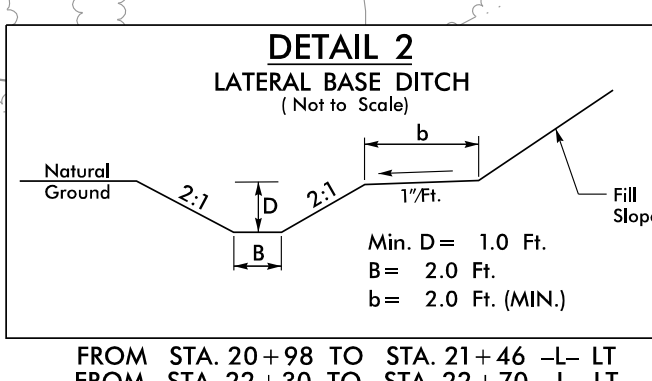
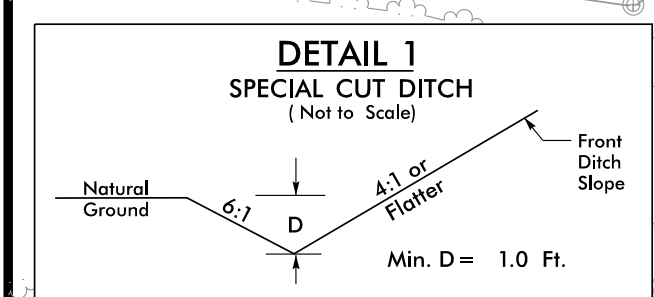
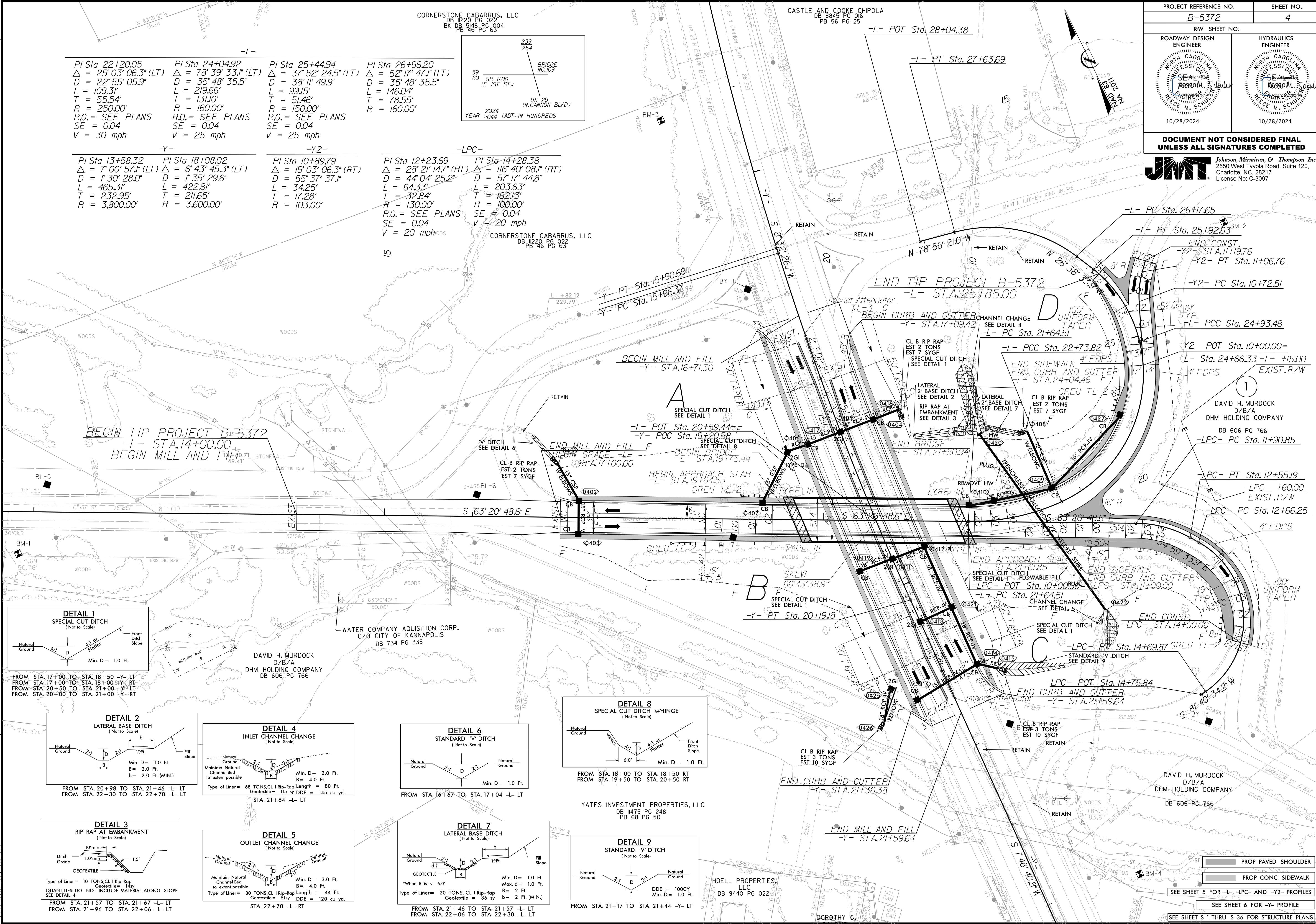

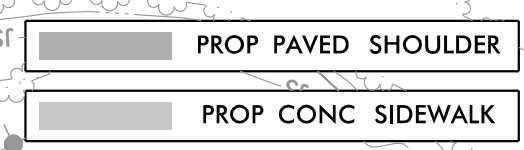

 SEE SHEET 5 FOR -L-, -LPC- AND -Y2- PROFILES
 SEE SHEET 6 FOR -Y- PROFILE
 SEE SHEET S-1 THRU S-36 FOR STRUCTURE PLANS

10/16/2024 5:43:52 PM
User: psah04.dgn