

NOTES

STIRRUPS IN CAP MAY BE SHIFTED AS NECESSARY TO CLEAR DOWELS.

THE CONCRETE IN THE SHADED AREA OF THE WING SHALL BE POURED AFTER THE VERTICAL CONCRETE BARRIER RAIL IS CAST IF SLIP FORMING IS USED.

FOR PILE SPLICE DETAILS, SEE "END BENT DETAILS" SHEET.

FOR WING DETAILS, SEE "END BENT WING DETAILS" SHEET.

FOR SECTION A-A, SEE "END BENT DETAILS" SHEET.

FOR TEMPORARY DRAINAGE AT END BENT DETAIL, SEE "END BENT DETAILS" SHEET.

CONCRETE COLLARS FOR STEEL PILES NOT SHOWN IN PLAN AND ELEVATION VIEWS. SEE "CORROSION PROTECTION FOR STEEL PILES DETAIL" ON "END BENT DETAILS" SHEET.

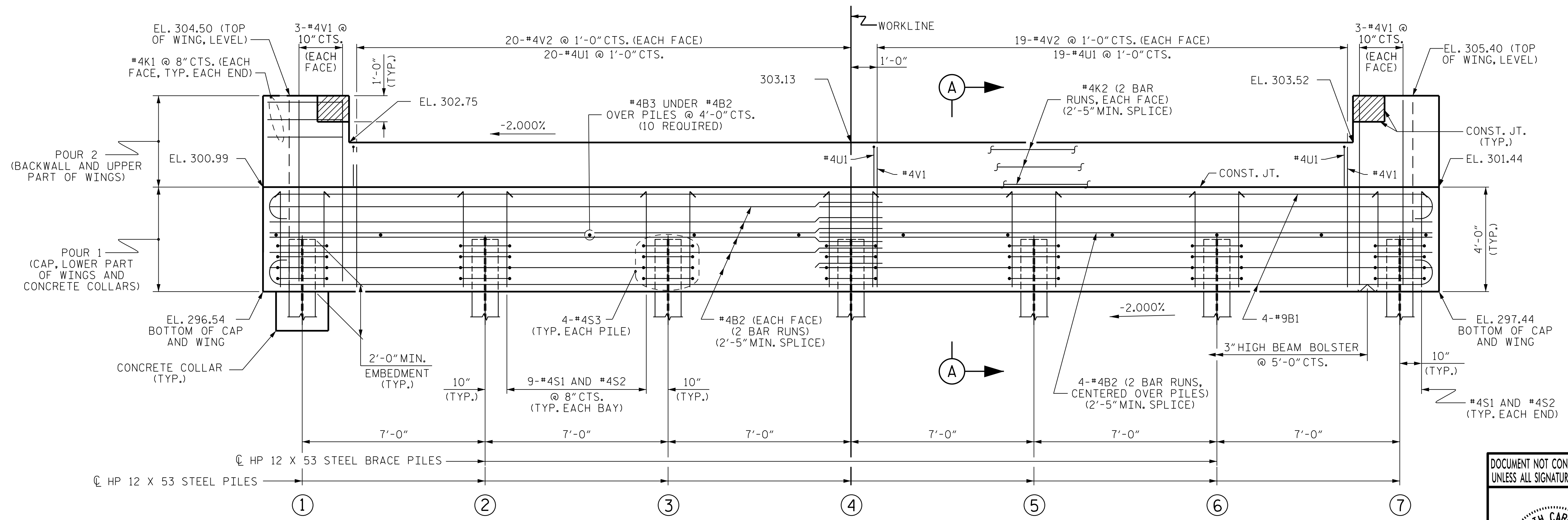

PILE CHART	
LOCATION	TOP OF PILE ELEVATION
①	298.58
②	298.72
③	298.86
④	299.00
⑤	299.14
⑥	299.28
⑦	299.42

PROJECT NO. **BR-0063**
ANSON COUNTY
 STATION: **20+15.00 -L-**

STATE OF NORTH CAROLINA
 DEPARTMENT OF TRANSPORTATION
 RALEIGH
SUBSTRUCTURE
END BENT 2

DOCUMENT NOT CONSIDERED FINAL
 UNLESS ALL SIGNATURES COMPLETED

NORTH CAROLINA
 PROFESSIONAL
 SEAL
 046289
G. P. HOOVER
 ENGINEER

ASSEMBLED BY : K. E. LOFTON DATE : 6-22
 CHECKED BY : G. P. HOOVER DATE : 9-23
 DRAWN BY : WJH 12/11 REV. 4/15 MAA/TMG
 CHECKED BY : AAC 12/11

DRAWN BY : K. E. LOFTON DATE : 6-22
 CHECKED BY : G. P. HOOVER DATE : 9-23
 ENGINEER OF RECORD : G. P. HOOVER DATE : 9-23

PLANS PREPARED BY :
ARCADIS
 175 REGENCY WOOD PLACE, SUITE 400
 CARY, NORTH CAROLINA 27518
 NC LICENSE No. 0486277
 FOR NORTH CAROLINA DEPARTMENT OF TRANSPORTATION

REVISIONS						SHEET No.
No.	BY:	DATE:	No.	BY:	DATE:	TOTAL SHEETS
1			3			19
2			4			