

09\_08/24/9

STATE	STATE PROJECT REFERENCE NO.	SHEET NO.	TOTAL SHEETS
N.C.	W-5601EX	1	
STATE PROJ. NO.	F.A. PROJ. NO.	DESCRIPTION	
	W-5601EX		
50138.1.155	HSIP-0042(66)	PE	
50138.2.155	HSIP-0042(66)	R/W & UTIL	
50138.3.155	HSIP-0042(66)	CONST.	
	W-5601EY		
50138.1.156	HSIP-0042(67)	PE	
50138.2.155	HSIP-0042(66)	R/W & UTIL	

STATE OF NORTH CAROLINA  
DIVISION OF HIGHWAYS  
**WAKE COUNTY**

**LOCATION: WIDEN NC 42 FOR CENTER TURN LANE FROM WEST OF MARY HOBBY ROAD (SR 2734) TO EAST OF WINTERTON DRIVE (SR 5367) AND CONSTRUCT AN EASTBOUND LEFT TURN LANE ON NC 42 AT THE SAULS ROAD (SR 2727) INTERSECTION**

**TYPE OF WORK: GRADING, DRAINAGE, PAVING, AND CULVERT**

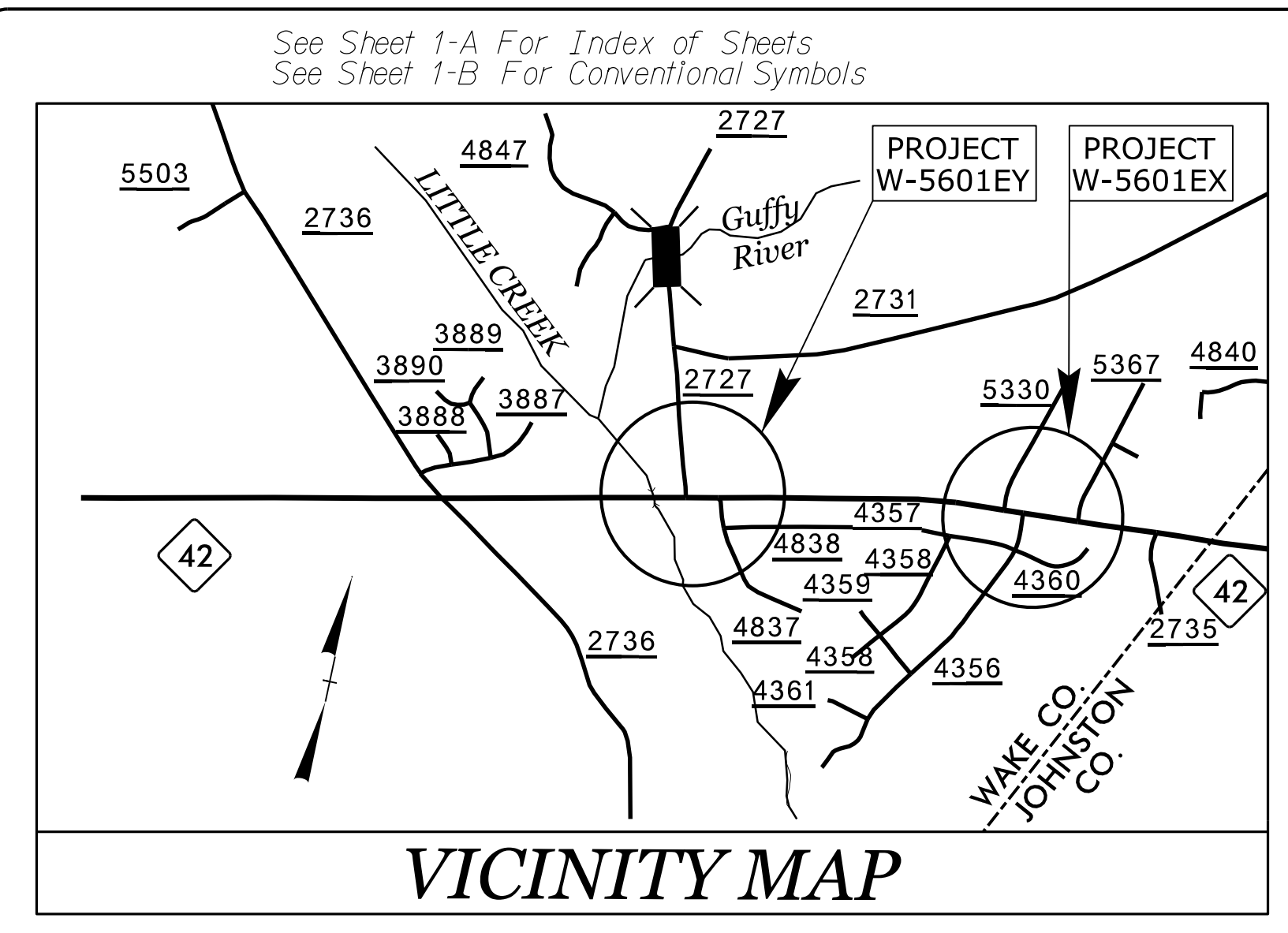

**CONTRACT: C204987 TIP PROJECT: W-5601EX**

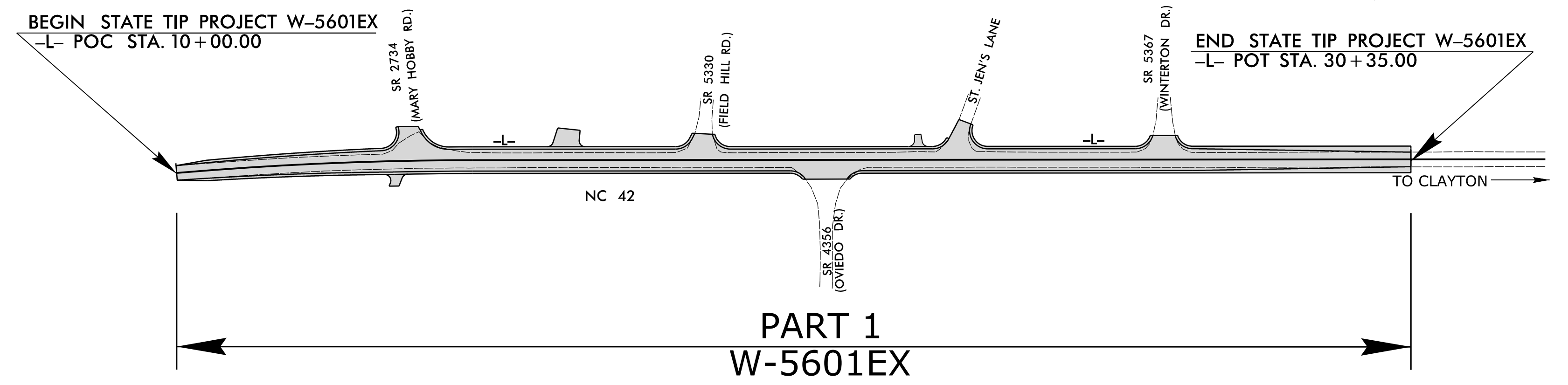
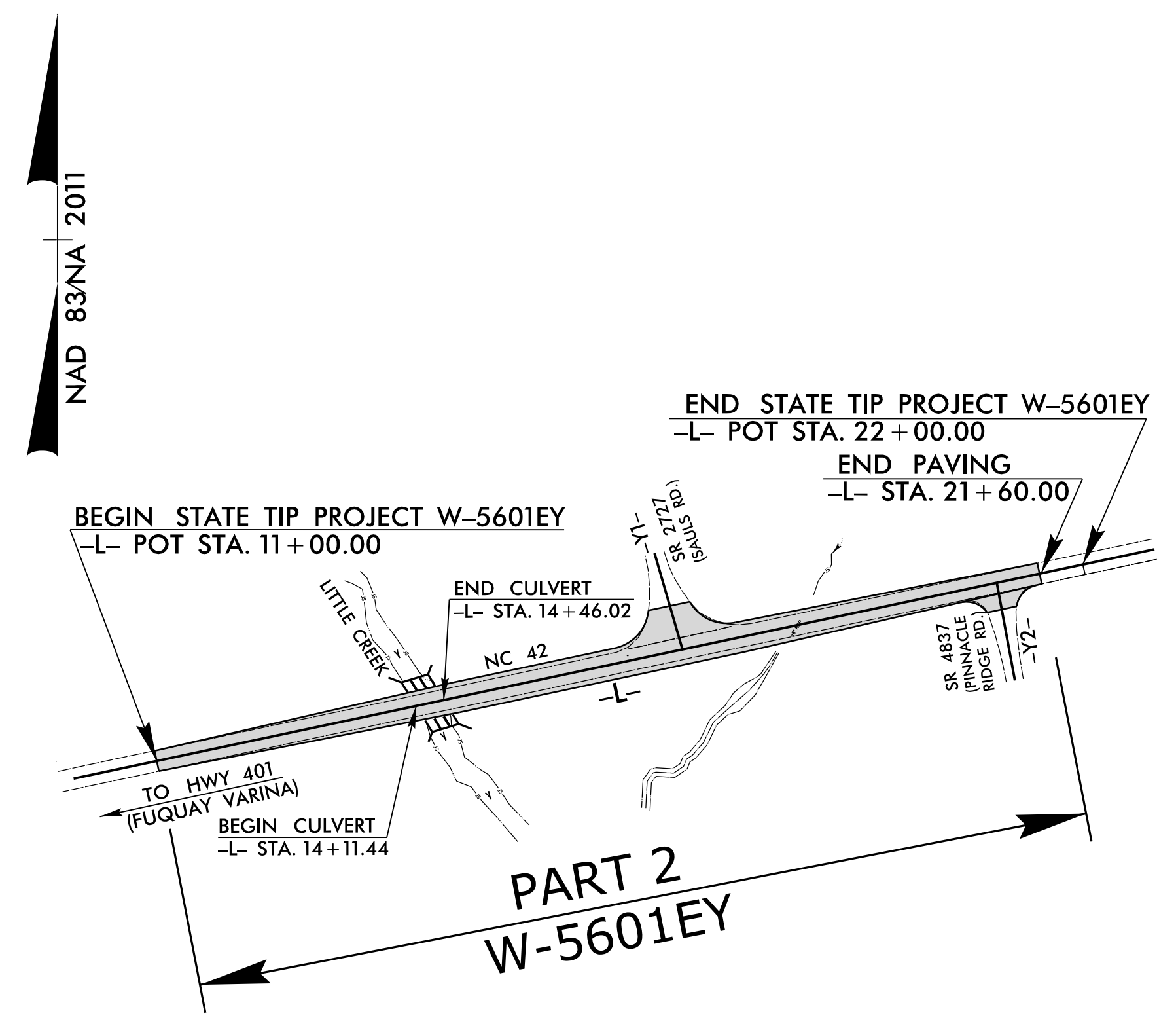

NOTE: W-5601EY WAS DELETED. THE WORK FROM W-5601EY WAS INCORPORATED INTO W-5601EX.

DOCUMENT NOT CONSIDERED FINAL UNLESS ALL SIGNATURES COMPLETED

PROJECT LENGTH
LENGTH OF ROADWAY TIP PROJECT W-5601EX = .385 MILES
LENGTH OF ROADWAY TIP PROJECT W-5601EY = .208 MILES
<b>TOTAL LENGTH OF TIP PROJECT W-5601EX /W-5601EY = .593 MILES</b>

Prepared in the Office of:  
KCI Associates of N.C., P.A.  
4505 Falls of Neuse Road  
Suite 400  
Raleigh, NC 27609  
Phone (919) 783-9214  
Fax (919) 783-9266

Plans Prepared For:  
**NCDOT DIVISION 5**  
2612 N. Duke St.  
Durham NC, 27704

2024 STANDARD SPECIFICATIONS

**RIGHT OF WAY DATE W-5601EX:**  
August 19, 2019

**RIGHT OF WAY DATE W-5601EY:**  
August 19, 2021

**LETTING DATE:**  
November 19, 2024

**HYDRAULICS ENGINEER**

Signed by:  
**Josh Dalton**  
1089AD8C14994C3...  
P.E. 9/9/2024

**ROADWAY DESIGN ENGINEER**

DocuSigned by:  
**Charlie Flow**  
FEAE01D0D8C74EA...  
P.E. 5/9/2024

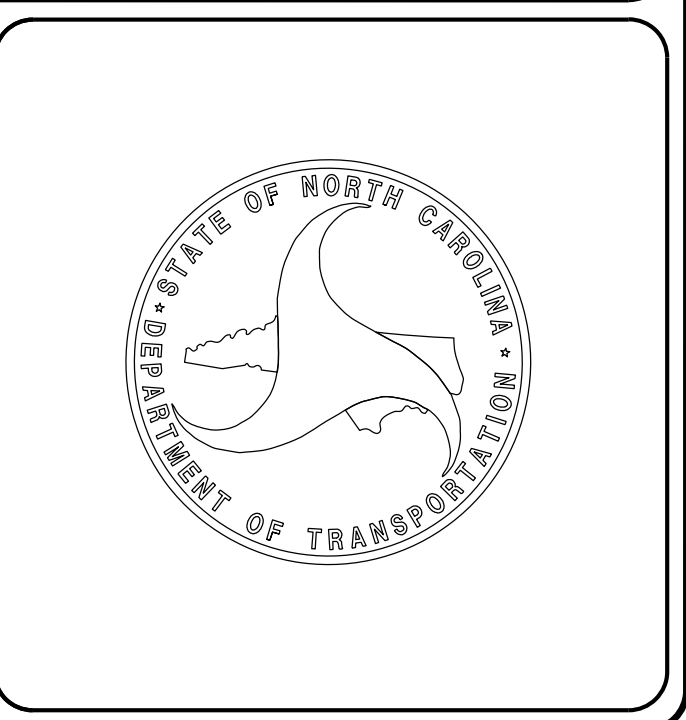

09-SEP-2024 08:58  
M:\2025\221333\95\_04 NCDOT W-5601EX\_Roadway\Proj\W-5601EX\_Rdy\_+tsh - Combined.dgn  
\$\$\$\$SERVNAME\$\$\$\$

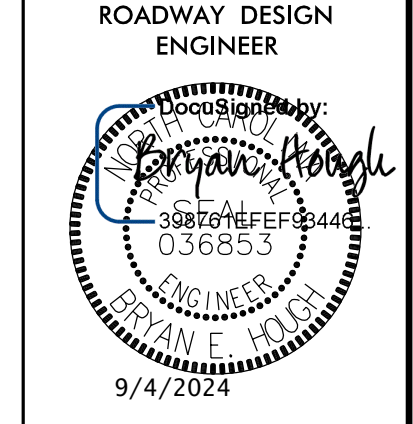

SHEET NUMBER	SHEET
1	TITLE SHEET
1A	INDEX OF SHEETS, GENERAL NOTES, AND STANDARD DRAWINGS
1B	CONVENTIONAL SYMBOLS
PART 1 (W-5601EX)	
1	TITLE SHEET
2A-1	TYPICAL SECTIONS, PAVEMENT SCHEDULE AND LAP JOINT DETAIL
2C-1 TO 2C-2	METHOD OF PIPE INSTALLATION
2D-1	DRAINAGE DITCH DETAILS
3B-1	SUMMARY OF EARTHWORK AND PARCEL INDEX
3D-1	DRAINAGE SUMMARY SHEET
4 TO 5	PLAN AND PROFILE SHEET
RW-01 TO RW-05	RIGHT OF WAY SHEETS
TMP-1 TO TMP-3	TRANSPORTATION MANAGEMENT PLANS
PMP-1 TO PMP-5	PAVEMENT MARKING PLANS
EC-1 TO EC-7	EROSION CONTROL PLANS
UC-1 TO UC-6	UTILITY CONSTRUCTION PLANS
UO-1 TO UO-3	UTILITIES BY OTHERS PLANS
X-0	CROSS SECTION SUMMARY SHEET
X-1 TO X-6	CROSS-SECTIONS
PART 2 (W-5601EY)	
1	TITLE SHEET
2A-1	TYPICAL SECTIONS, PAVEMENT SCHEDULE, WEDGING DETAIL, AND INCIDENTAL MILLING DETAIL
2C-1	GUARDRAIL PLACEMENT DETAIL
2C-2 TO 2C-3	METHOD OF PIPE INSTALLATION
2D-1	SPECIAL JUNCTION BOX WITH SLAB LID DETAIL
2D-2	DRAINAGE DITCH DETAILS
3B-1	SUMMARY OF EARTHWORK, PARCEL INDEX SHEET, AND SUMMARY OF GUARDRAIL
3D-1 TO 3D-2	DRAINAGE SUMMARY SHEET
4	PLAN AND PROFILE SHEET
RW-01 TO RW-04A	RIGHT OF WAY SHEETS
TMP-1 TO TMP-2	TRANSPORTATION MANAGEMENT PLANS
PMP-1 TO PMP-2	PAVEMENT MARKING PLANS
EC-1 TO EC-5	EROSION CONTROL PLANS
RF-1	REFORESTATION PLANS
UC-1 TO UC-5	UTILITY CONSTRUCTION PLANS
UO-1 TO UO-2	UTILITIES BY OTHERS PLANS
X-0	CROSS SECTION SUMMARY SHEET
X-1 TO X-4	CROSS-SECTIONS
C-1 TO C-12	CULVERT PLANS

GENERAL NOTES: 2024 SPECIFICATIONS EFFECTIVE: 01-16-2024

GRADING AND SURFACING OR RESURFACING AND WIDENING: THE GRADE LINES SHOWN DENOTE THE FINISHED ELEVATION OF THE PROPOSED SURFACING AT GRADE POINTS SHOWN ON THE TYPICAL SECTIONS. WHERE NO GRADE LINES ARE SHOWN, THE PROFILES SHOWN DENOTE THE TOP ELEVATION OF THE EXISTING PAVEMENT ALONG THE CENTER LINE OF SURVEY ON WHICH THE PROPOSED RESURFACING WILL BE PLACED. GRADE LINES MAY BE ADJUSTED BY THE ENGINEER IN ORDER TO SECURE A PROPER TIE-IN.

CLEARING: CLEARING ON THIS PROJECT SHALL BE PERFORMED TO THE LIMITS ESTABLISHED BY METHOD III.

SUPERELEVATION: ALL CURVES ON THIS PROJECT SHALL BE SUPERELEVATED IN ACCORDANCE WITH STD. NO. 225.04 USING THE RATE OF SUPERELEVATION AND RUNOFF SHOWN ON THE PLANS. SUPERELEVATION IS TO BE REVOLVED ABOUT THE GRADE POINTS SHOWN ON THE TYPICAL SECTIONS.

SHOULDER CONSTRUCTION: ASPHALT, EARTH, AND CONCRETE SHOULDER CONSTRUCTION ON THE HIGH SIDE OF SUPERELEVATED CURVES SHALL BE IN ACCORDANCE WITH STD. NO. 560.01

SIDE ROADS: THE CONTRACTOR WILL BE REQUIRED TO DO ALL NECESSARY WORK TO PROVIDE SUITABLE CONNECTIONS WITH ALL ROADS, STREETS, AND DRIVES ENTERING THIS PROJECT. THIS WORK WILL BE PAID FOR AT THE CONTRACT UNIT PRICE FOR THE PARTICULAR ITEMS INVOLVED.

DRIVEWAYS: DRIVEWAYS SHALL BE CONSTRUCTED IN ACCORDANCE WITH STD. 848.02 USING 3 FOOT RADII OR RADII AS SHOWN ON THE PLANS. LOCATIONS OF DRIVES WILL BE AS SHOWN ON THE PLANS OR AS DIRECTED BY THE ENGINEER.

STREET TURNOUT: STREET RETURNS SHALL BE CONSTRUCTED IN ACCORDANCE WITH STD. NO. 848.04 USING THE RADII NOTED ON PLANS.

GUARDRAIL: THE GUARDRAIL LOCATIONS SHOWN ON THE PLANS MAY BE ADJUSTED DURING CONSTRUCTION AS DIRECTED BY THE ENGINEER. THE CONTRACTOR SHOULD CONSULT WITH THE ENGINEER PRIOR TO ORDERING GUARDRAIL MATERIAL.

TEMPORARY SHORING: SHORING REQUIRED FOR THE MAINTENANCE OF TRAFFIC WILL BE PAID FOR AS "EXTRA WORK" IN ACCORDANCE WITH SECTION 104-7.

SUBSURFACE PLANS: NO SUBSURFACE PLANS ARE AVAILABLE ON THIS PROJECT. THE CONTRACTOR SHOULD MAKE HIS OWN INVESTIGATION AS TO THE SUBSURFACE CONDITIONS.

UTILITIES: UTILITY OWNERS ON THIS PROJECT ARE:  
 W-5601EX: DUKE ENERGY, CHARTER/SPECTRUM, AT&T AND JOHNSTON COUNTY WATER DEPARTMENT  
 W-5601EY: DUKE ENERGY, CHARTER/SPECTRUM, AT&T AND JOHNSTON COUNTY WATER DEPARTMENT

ANY RELOCATION OF EXISTING UTILITIES WILL BE ACCOMPLISHED BY OTHERS, EXCEPT AS SHOWN ON THE PLANS.

RIGHT-OF-WAY MARKERS: ALL RIGHT-OF-WAY MARKERS ON THIS PROJECT SHALL BE PLACE BY OTHERS.

2024 ROADWAY ENGLISH STANDARD DRAWINGS

The following Roadway Standards as appear in "Roadway Standard Drawings" Highway Design Branch - N. C. Department of Transportation - Raleigh, N. C., Dated January, 2024 are applicable to this project and by reference hereby are considered a part of these plans:

STD. NO.	TITLE
DIVISION 2 - EARTHWORK	
200.03	Method of Clearing - Method III
225.02	Guide for Grading Subgrade - Secondary and Local
225.04	Method of Obtaining Superelevation - Two Lane Pavement
DIVISION 3 - PIPE CULVERTS	
310.10	Driveway Pipe Construction
DIVISION 5 - SUBGRADE, BASES AND SHOULDERS	
560.01	Method of Shoulder Construction - High Side of Superelevated Curve - Method I
DIVISION 6 - ASPHALT BASES AND PAVEMENTS	
654.01	Pavement Repairs
DIVISION 8 - INCIDENTALS	
838.01	Concrete Endwall for Single and Double Pipe Culverts - 15" thru 48" Pipe 90 Skew
838.11	Brick Endwall for Single and Double Pipe Culverts - 15" thru 48" Pipe 90 Skew
838.39	Reinforced Concrete Endwall - for Single 72" Pipe 90 Skew
838.45	Notes for Reinforce Concrete Endwall - Std. Dwg 838.21 thru 838.40
838.69	Reinforced Brick Endwall - for Single 72" Pipe 90 Skew
838.75	Notes for Reinforced Brick Endwall - Std. Dwg 838.51 thru 838.70
838.80	Precast Endwalls - 12" thru 72" Pipe 90 Skew
840.00	Concrete Base Pad for Drainage Structures
840.72	Pipe Collar
848.04	Street Turnout
862.01	Guardrail Placement
862.02	Guardrail Installation
876.01	Rip Rap in Channels and Ditches
876.02	Guide for Rip Rap at Pipe Outlets
876.04	Drainage Ditches with Class 'B' Rip Rap

EFF. 01-16-2024

**DOCUMENT NOT CONSIDERED FINAL  
UNLESS ALL SIGNATURES COMPLETED**



# STATE OF NORTH CAROLINA, DIVISION OF HIGHWAYS CONVENTIONAL PLAN SHEET SYMBOLS

Note: Not to Scale

## BOUNDARIES AND PROPERTY:

State Line	-----	
County Line	-----	
Township Line	-----	
City Line	-----	
Reservation Line	-----	
Property Line	-----	
Existing Iron Pin (EIP)	-----	⊙
Computed Property Corner	-----	X
Existing Concrete Monument (ECM)	-----	⊠
Parcel/Sequence Number	-----	123
Existing Fence Line	-----	-x-x-x-
Proposed Woven Wire Fence	-----	o
Proposed Chain Link Fence	-----	□
Proposed Barbed Wire Fence	-----	◇
Existing Wetland Boundary	-----	WLB
Proposed Wetland Boundary	-----	WLB
Existing Endangered Animal Boundary	-----	EAB
Existing Endangered Plant Boundary	-----	EPB
Existing Historic Property Boundary	-----	HPB
Known Contamination Area: Soil	-----	⊗-s-⊗-s-
Potential Contamination Area: Soil	-----	⊗-s-⊗-s-
Known Contamination Area: Water	-----	⊗-w-⊗-w-
Potential Contamination Area: Water	-----	⊗-w-⊗-w-
Contaminated Site: Known or Potential	-----	☠ ☠

## BUILDINGS AND OTHER CULTURE:

Gas Pump Vent or U/G Tank Cap	-----	○
Sign	-----	⊙
Well	-----	⊙
Small Mine	-----	⊗
Foundation	-----	⊠
Area Outline	-----	⊠
Cemetery	-----	⊠
Building	-----	⊠
School	-----	⊠
Church	-----	⊠
Dam	-----	⊠

## HYDROLOGY:

Stream or Body of Water	-----	
Hydro, Pool or Reservoir	-----	⊠
Jurisdictional Stream	-----	JS
Buffer Zone 1	-----	BZ 1
Buffer Zone 2	-----	BZ 2
Flow Arrow	-----	←
Disappearing Stream	-----	→
Spring	-----	⊙
Wetland	-----	⊠
Proposed Lateral, Tail, Head Ditch	-----	⊠
False Sump	-----	⊠

## RAILROADS:

Standard Gauge	-----	⊠
RR Signal Milepost	-----	⊙
Switch	-----	⊠
RR Abandoned	-----	-----
RR Dismantled	-----	-----

## RIGHT OF WAY & PROJECT CONTROL:

Primary Horiz Control Point	-----	⊠
Primary Horiz and Vert Control Point	-----	⊠
Secondary Horiz and Vert Control Point	-----	⊠
Vertical Benchmark	-----	⊠
Existing Right of Way Monument	-----	⊠
Proposed Right of Way Monument (Rebar and Cap)	-----	⊠
Proposed Right of Way Monument (Concrete)	-----	⊠
Existing Permanent Easement Monument	-----	⊠
Proposed Permanent Easement Monument (Rebar and Cap)	-----	⊠
Existing C/A Monument	-----	⊠
Proposed C/A Monument (Rebar and Cap)	-----	⊠
Proposed C/A Monument (Concrete)	-----	⊠
Existing Right of Way Line	-----	-----
Proposed Right of Way Line	-----	-----
Existing Control of Access Line	-----	-----
Proposed Control of Access Line	-----	-----
Proposed ROW and CA Line	-----	-----
Existing Easement Line	-----	-----
Proposed Temporary Construction Easement	-----	-----
Proposed Temporary Drainage Easement	-----	-----
Proposed Permanent Drainage Easement	-----	-----
Proposed Permanent Drainage/Utility Easement	-----	-----
Proposed Permanent Utility Easement	-----	-----
Proposed Temporary Utility Easement	-----	-----
Proposed Aerial Utility Easement	-----	-----

## ROADS AND RELATED FEATURES:

Existing Edge of Pavement	-----	-----
Existing Curb	-----	-----
Proposed Slope Stakes Cut	-----	-----
Proposed Slope Stakes Fill	-----	-----
Proposed Curb Ramp	-----	-----
Existing Metal Guardrail	-----	-----
Proposed Guardrail	-----	-----
Existing Cable Guiderail	-----	-----
Proposed Cable Guiderail	-----	-----
Equality Symbol	-----	-----
Pavement Removal	-----	-----
VEGETATION:		
Single Tree	-----	⊠
Single Shrub	-----	⊠
Hedge	-----	-----

Woods Line	-----	-----
Orchard	-----	-----
Vineyard	-----	-----

## EXISTING STRUCTURES:

MAJOR:		
Bridge, Tunnel or Box Culvert	-----	-----
Bridge Wing Wall, Head Wall and End Wall	-----	-----
MINOR:		
Head and End Wall	-----	-----
Pipe Culvert	-----	-----
Footbridge	-----	-----
Drainage Box: Catch Basin, DI or JB	-----	-----
Paved Ditch Gutter	-----	-----
Storm Sewer Manhole	-----	-----
Storm Sewer	-----	-----

## UTILITIES:

\* SUE - Subsurface Utility Engineering  
LOS - Level of Service - A, B, C or D (Accuracy)

POWER:		
Existing Power Pole	-----	-----
Proposed Power Pole	-----	-----
Existing Joint Use Pole	-----	-----
Proposed Joint Use Pole	-----	-----
Power Manhole	-----	-----
Power Line Tower	-----	-----
Power Transformer	-----	-----
U/G Power Cable Hand Hole	-----	-----
H-Frame Pole	-----	-----
U/G Power Line Test Hole (SUE - LOS A)*	-----	-----
U/G Power Line (SUE - LOS B)*	-----	-----
U/G Power Line (SUE - LOS C)*	-----	-----
U/G Power Line (SUE - LOS D)*	-----	-----

## TELEPHONE:

Existing Telephone Pole	-----	-----
Proposed Telephone Pole	-----	-----
Telephone Manhole	-----	-----
Telephone Pedestal	-----	-----
Telephone Cell Tower	-----	-----
U/G Telephone Cable Hand Hole	-----	-----
U/G Telephone Test Hole (SUE - LOS A)*	-----	-----
U/G Telephone Cable (SUE - LOS B)*	-----	-----
U/G Telephone Cable (SUE - LOS C)*	-----	-----
U/G Telephone Cable (SUE - LOS D)*	-----	-----
U/G Telephone Conduit (SUE - LOS B)*	-----	-----
U/G Telephone Conduit (SUE - LOS C)*	-----	-----
U/G Telephone Conduit (SUE - LOS D)*	-----	-----
U/G Fiber Optics Cable (SUE - LOS B)*	-----	-----
U/G Fiber Optics Cable (SUE - LOS C)*	-----	-----
U/G Fiber Optics Cable (SUE - LOS D)*	-----	-----

## WATER:

Water Manhole	-----	-----
Water Meter	-----	-----
Water Valve	-----	-----
Water Hydrant	-----	-----
U/G Water Line Test Hole (SUE - LOS A)*	-----	-----
U/G Water Line (SUE - LOS B)*	-----	-----
U/G Water Line (SUE - LOS C)*	-----	-----
U/G Water Line (SUE - LOS D)*	-----	-----
Above Ground Water Line	-----	-----

## TV:

TV Pedestal	-----	-----
TV Tower	-----	-----
U/G TV Cable Hand Hole	-----	-----
U/G TV Test Hole (SUE - LOS A)*	-----	-----
U/G TV Cable (SUE - LOS B)*	-----	-----
U/G TV Cable (SUE - LOS C)*	-----	-----
U/G TV Cable (SUE - LOS D)*	-----	-----
U/G Fiber Optic Cable (SUE - LOS B)*	-----	-----
U/G Fiber Optic Cable (SUE - LOS C)*	-----	-----
U/G Fiber Optic Cable (SUE - LOS D)*	-----	-----

## GAS:

Gas Valve	-----	-----
Gas Meter	-----	-----
U/G Gas Line Test Hole (SUE - LOS A)*	-----	-----
U/G Gas Line (SUE - LOS B)*	-----	-----
U/G Gas Line (SUE - LOS C)*	-----	-----
U/G Gas Line (SUE - LOS D)*	-----	-----
Above Ground Gas Line	-----	-----

## SANITARY SEWER:

Sanitary Sewer Manhole	-----	-----
Sanitary Sewer Cleanout	-----	-----
U/G Sanitary Sewer Line	-----	-----
Above Ground Sanitary Sewer	-----	-----
SS Force Main Line Test Hole (SUE - LOS A)*	-----	-----
SS Force Main Line (SUE - LOS B)*	-----	-----
SS Force Main Line (SUE - LOS C)*	-----	-----
SS Force Main Line (SUE - LOS D)*	-----	-----

## MISCELLANEOUS:

Utility Pole	-----	-----
Utility Pole with Base	-----	-----
Utility Located Object	-----	-----
Utility Traffic Signal Box	-----	-----
Utility Unknown U/G Line (SUE - LOS B)*	-----	-----
U/G Tank; Water, Gas, Oil	-----	-----
Underground Storage Tank, Approx. Loc.	-----	-----
A/G Tank; Water, Gas, Oil	-----	-----
Geoenvironmental Boring	-----	-----
Abandoned According to Utility Records	-----	-----
End of Information	-----	-----

09/08/2019

04-SEP-2024 08:22  
M:\2013\22133395\04 NCDOT W-5601EX\Roadway\Proj\W-5601EX\_Rdy\_+tsh.dgn  
\$\$\$\$\$SERNAME\$\$\$\$\$

**TIP PROJECT: W-5601EX**

**CONTRACT: C204987**

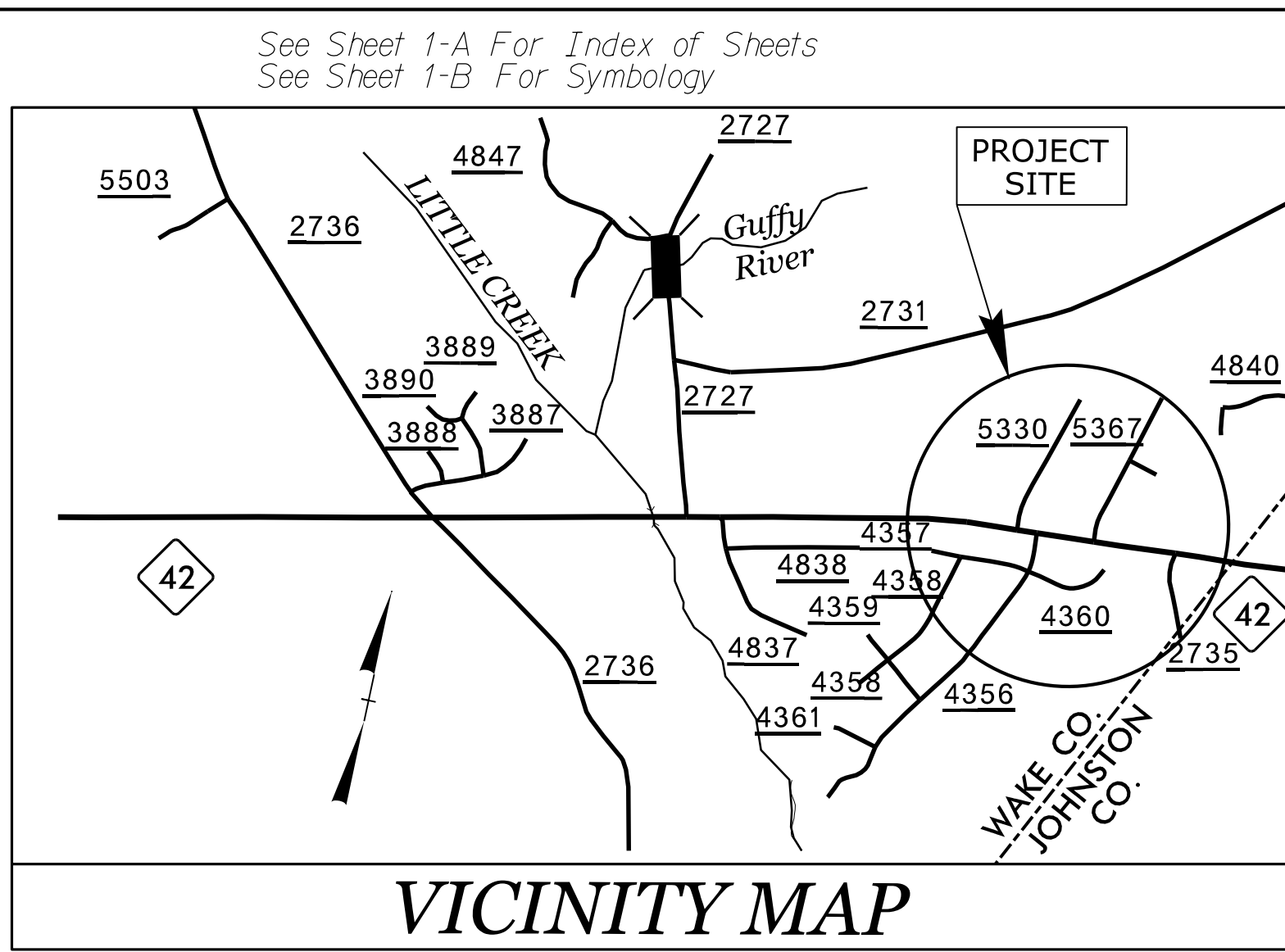

STATE OF NORTH CAROLINA  
DIVISION OF HIGHWAYS

# WAKE COUNTY

**LOCATION: WIDEN NC 42 FOR CENTER TURN LANE FROM WEST OF MARY HOBBY ROAD (SR 2734) TO EAST OF WINTERTON DRIVE (SR 5367)**

**TYPE OF WORK: GRADING, DRAINAGE AND PAVING**

STATE	STATE PROJECT REFERENCE NO.	SHEET NO.	TOTAL SHEETS
N.C.	W-5601EX	1	
STATE PROJ. NO.	F.A. PROJ. NO.	DESCRIPTION	
50138.1.155	HSIP-0042(066)	PE	
50138.2.155	HSIP-0042(066)	RW & UTIL.	
50138.3.155	HSIP-0042(066)	CONST.	

## PART 1

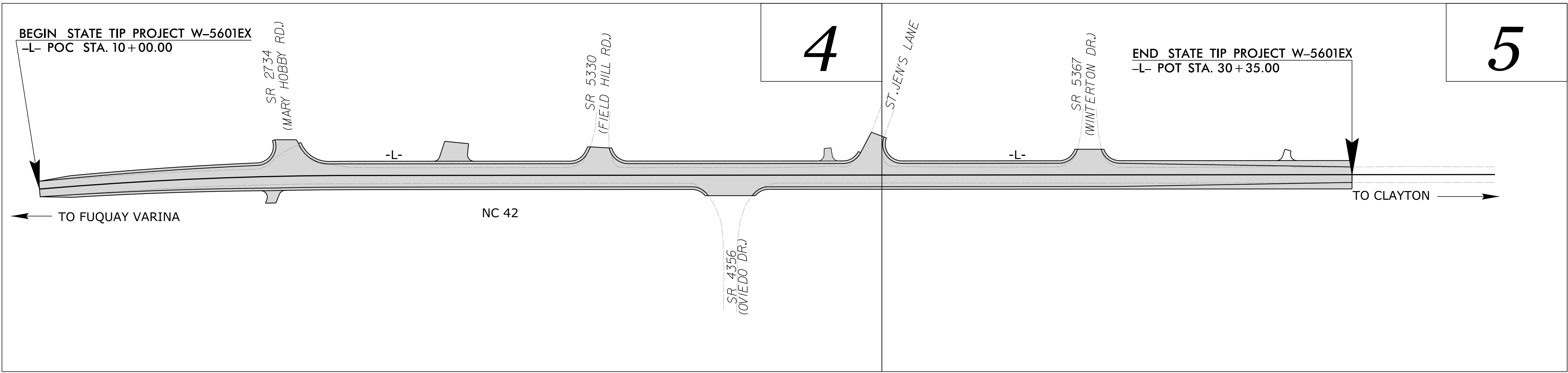
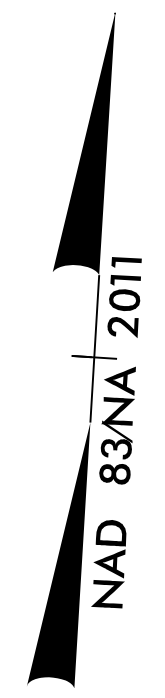

DOCUMENT NOT CONSIDERED FINAL  
UNLESS ALL SIGNATURES COMPLETED

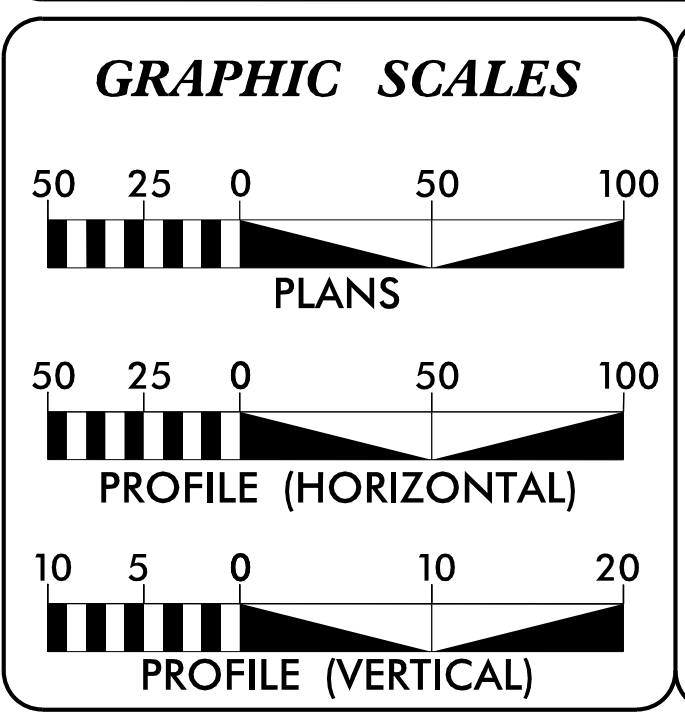

**DESIGN DATA**

ADT 2020 = 14,000
ADT 2040 = 20,800
V = 60 MPH
FUNC CLASS = MINOR ARTERIAL
REGIONAL TIER

**PROJECT LENGTH**

LENGTH OF ROADWAY TIP PROJECT W-5601EX = .385 MILES

Prepared in the Office of:  
KCI Associates of N.C., P.A.  
4505 Falls of Neuse Road  
Suite 400  
Raleigh, NC 27609  
Phone (919) 783-9214  
Fax (919) 783-9266

Plans Prepared For:  
**NCDOT DIVISION 5**  
2612 N. Duke St.  
Durham NC, 27704

2024 STANDARD SPECIFICATIONS

**RIGHT OF WAY DATE:**  
August 19, 2019

**LETTING DATE:**  
November 19, 2024

**DEWAYNE L. SYKES, PE**  
PROJECT ENGINEER

**BRYAN E. HOUGH, P.E.**  
PROJECT DESIGN ENGINEER

**NCDOT CONTACT: STEPHEN R. DAVIDSON, PE**  
DIVISION DESIGN ENGINEER - DIVISION 5

**HYDRAULICS ENGINEER**

DocuSigned by:  
*Joshua G Dalton*  
1089AD8C14994C3...  
SIGNATURE: P.E. 9/5/2024

**ROADWAY DESIGN ENGINEER**

DocuSigned by:  
*Bryan Hough*  
398761EFEF93446...  
SIGNATURE: P.E. 9/4/2024

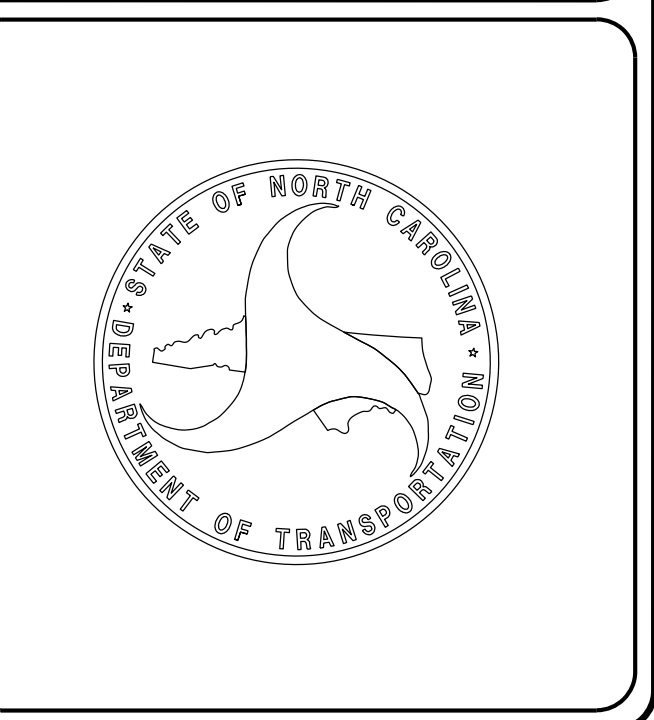

6/2/2024

FINAL PAVEMENT SCHEDULE	
C1	PROP. APPROX. 1.5" ASPHALT CONCRETE SURFACE COURSE, TYPE S9.5C, AT AN AVERAGE RATE OF 168 LBS. PER SQ. YD.
C2	PROP. APPROX. 3" ASPHALT CONCRETE SURFACE COURSE, TYPE S9.5C, AT AN AVERAGE RATE OF 168 LBS. PER SQ. YD. IN EACH OF TWO LAYERS.
D1	PROP. APPROX. 3" ASPHALT CONCRETE INTERMEDIATE COURSE, TYPE I19.0C, AT AN AVERAGE RATE OF 342 LBS. PER SQ. YD.
E1	PROP. APPROX. 5" ASPHALT CONCRETE BASE COURSE, TYPE B25.0C, AT AN AVERAGE RATE OF 570 LBS. PER SQ. YD.
T	EARTH MATERIAL
U	EXISTING PAVEMENT
V	1.5" MILLING. SEE LAP JOINT DETAIL

NOTE: ALL PAVEMENT EDGE SLOPES ARE 1:1 UNLESS OTHERWISE NOTED.

PROJECT REFERENCE NO. <b>W-5601EX</b>	SHEET NO. <b>2A-1</b>
ROADWAY DESIGN ENGINEER <i>[Signature]</i> 036853 9/4/2024	PAVEMENT DESIGN ENGINEER <i>[Signature]</i> 046017 9/5/2024
<b>DOCUMENT NOT CONSIDERED FINAL UNLESS ALL SIGNATURES COMPLETED</b>	
 <b>KCI</b> Engineers • Planners • Scientists • Construction Managers 4505 Falls of Neuse Road, Suite 400 Raleigh, NC 27609 Phone (919) 783-9214 • Fax (919) 783-9266	

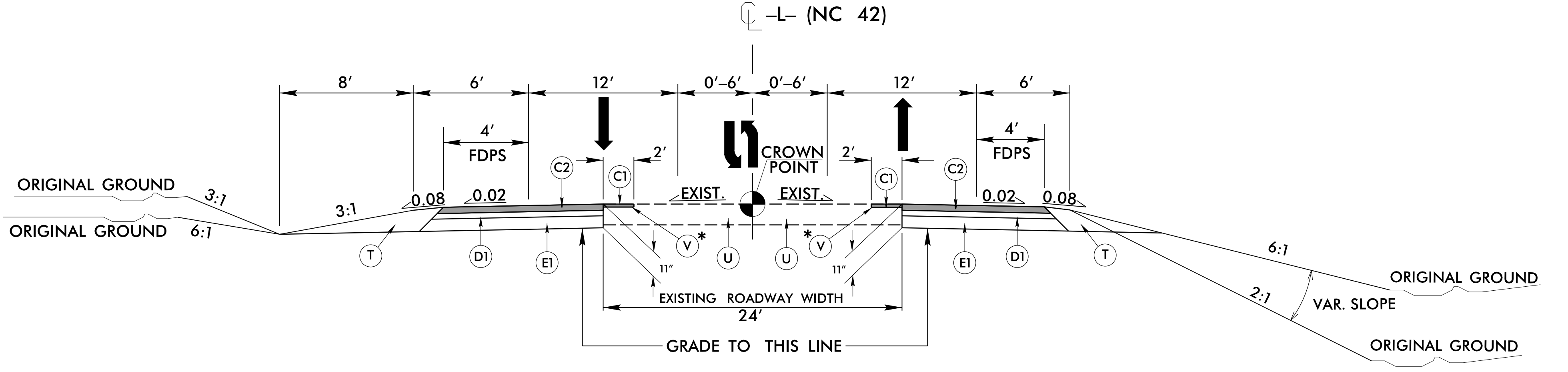

ROADWAY TYPICAL SECTION NO. 1

USE ROADWAY TYPICAL SECTION NO. 1  
-L- STA. 10+00.00 TO STA. 30+35.00

\* SEE LAP JOINT DETAIL

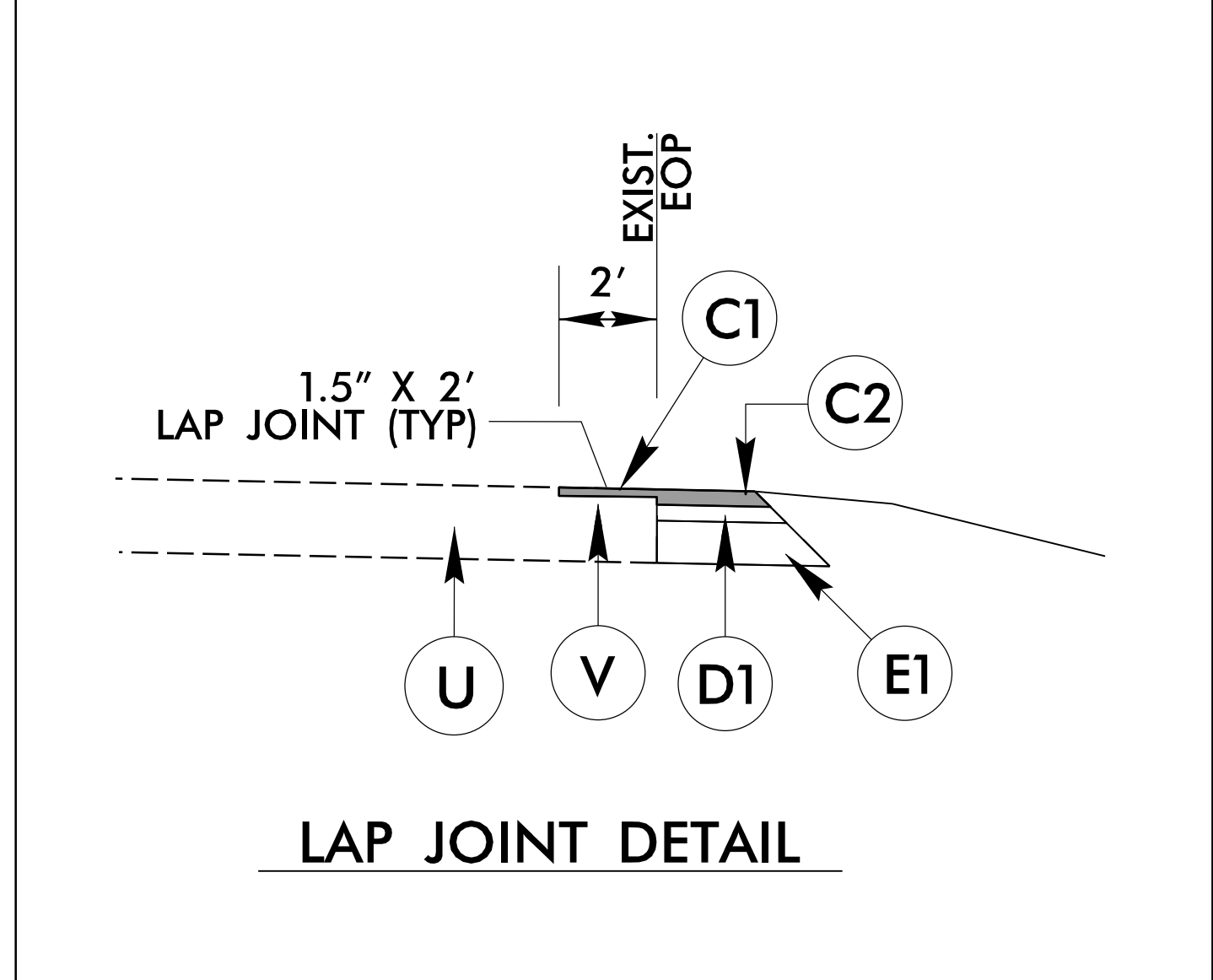



04\_SEP\_2024\_08:52  
 M:\2024\13333\13333\04\_NCDOT\_W-5601EX\Roadway\Proj\W-5601EX\_Rdy\_tjpd.dgn  
 USER:NAME\$

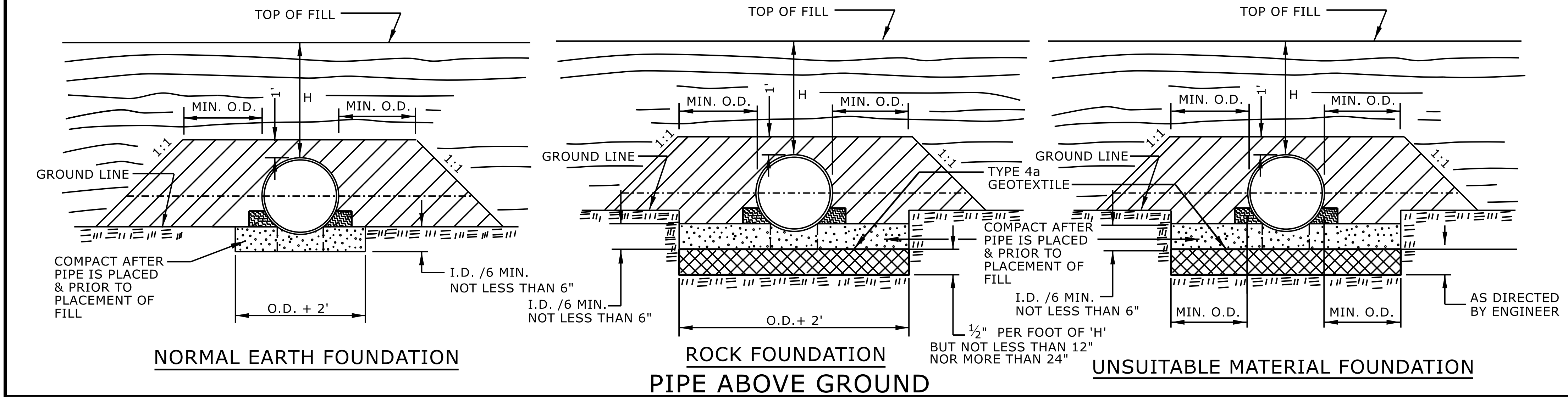
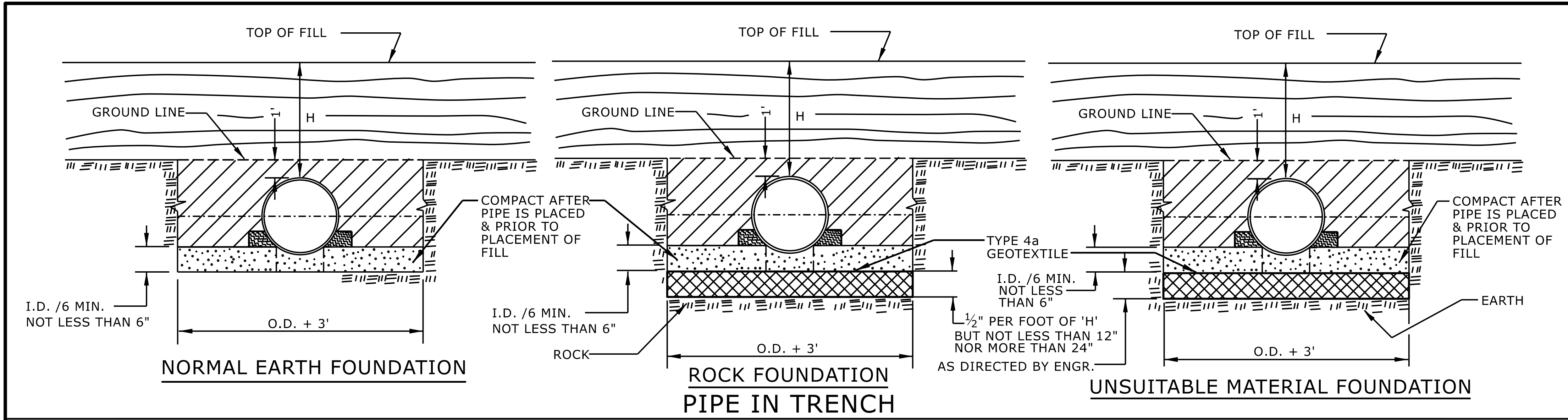



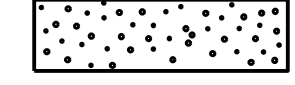

**GENERAL NOTES:**  
 I.D. = THE MAXIMUM HORIZONTAL INSIDE DIAMETER DIMENSION.  
 O.D. = THE MAXIMUM HORIZONTAL OUTSIDE DIAMETER DIMENSION.  
 H = THE FILL HEIGHT MEASURED VERTICALLY AT ANY POINT ALONG THE PIPE FROM THE TOP OF THE PIPE TO THE TOP OF THE EMBANKMENT AT THAT POINT.

 APPROVED SUITABLE LOCAL MATERIAL.  
 TAKE CARE TO FULLY COMPACT HAUNCH ZONE OF PIPE BACKFILL.  
 LOOSELY PLACED SELECT MATERIAL CLASS III OR CLASS II, TYPE 1 FOR PIPE BEDDING. LEAVE SECTION DIRECTLY BENEATH PIPE UNCOMPACTED AS PIPE SEATING AND BACKFILL WILL ACCOMPLISH COMPACTION.

DO NOT OPERATE HEAVY EQUIPMENT OVER ANY PIPE CULVERT UNTIL THE PIPE CULVERT HAS BEEN PROPERLY BACKFILLED AND COVERED WITH AT LEAST 3 FEET OF APPROVED MATERIAL.

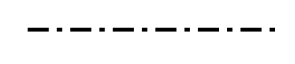
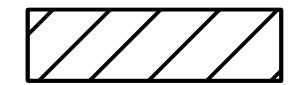
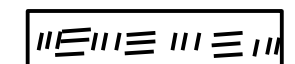
REFER TO NCDOT PIPE MATERIAL SELECTION GUIDE AND STANDARD SPECIFICATIONS FOR ALLOWABLE PIPE FILL HEIGHTS AND PIPE SPECIFICATIONS.

 SPRINGLINE OF PIPE  
 SELECT BACKFILL MATERIAL CLASS III OR CLASS II, TYPE 1 ABOVE AND BELOW SPRINGLINE.  
 UNDISTURBED EARTH MATERIAL  
 SELECT MATERIAL CLASS V OR VI FOR FOUNDATION CONDITIONING. ENCAPSULATE WITH TYPE IV GEOTEXTILE AS DIRECTED BY THE ENGINEER.

STATE OF NORTH CAROLINA  
 DEPT. OF TRANSPORTATION  
 DIVISION OF HIGHWAYS  
 RALEIGH, N.C.

ROADWAY DETAIL DRAWING FOR  
**METHOD OF PIPE INSTALLATION**  
 FLEXIBLE PIPE

SHEET 1 OF 2  
**300.01**

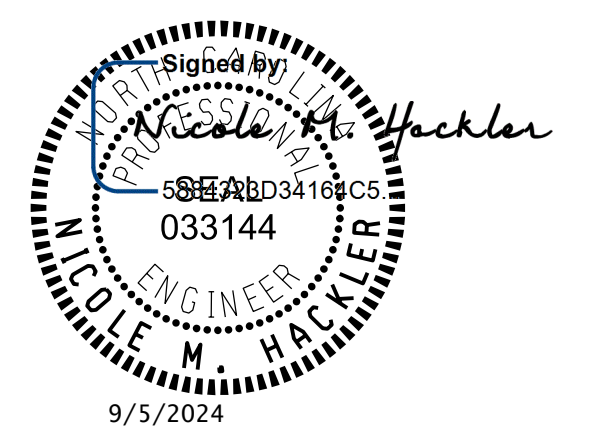

DOCUMENT NOT CONSIDERED FINAL  
 UNLESS ALL SIGNATURES COMPLETED



**CONTRACTS STANDARDS  
 AND DEVELOPMENT UNIT**  
 Office 919-707-6950 FAX 919-250-4119

**SEE TITLE BLOCK**

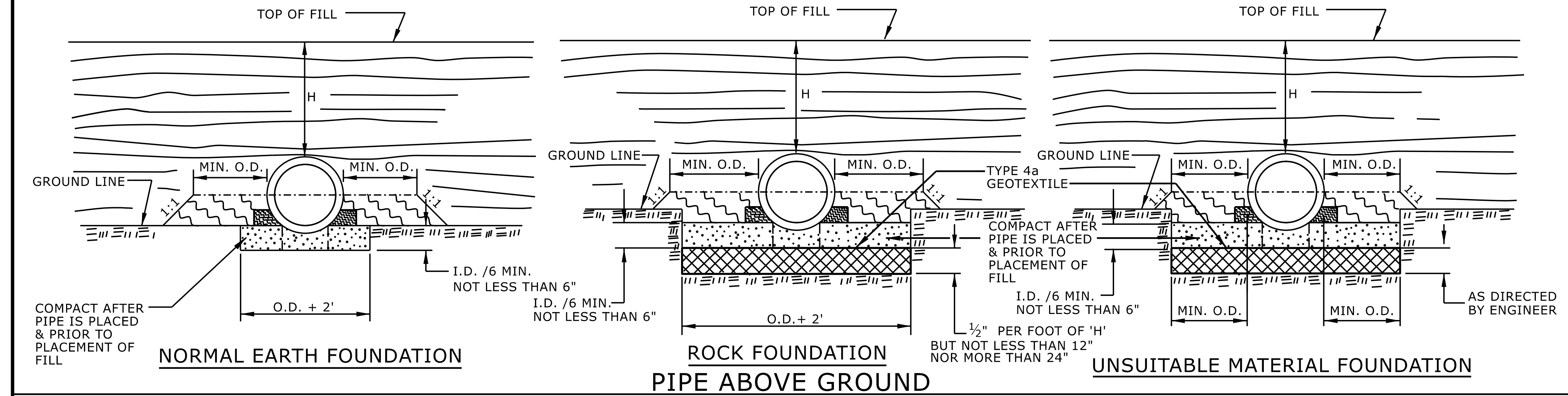
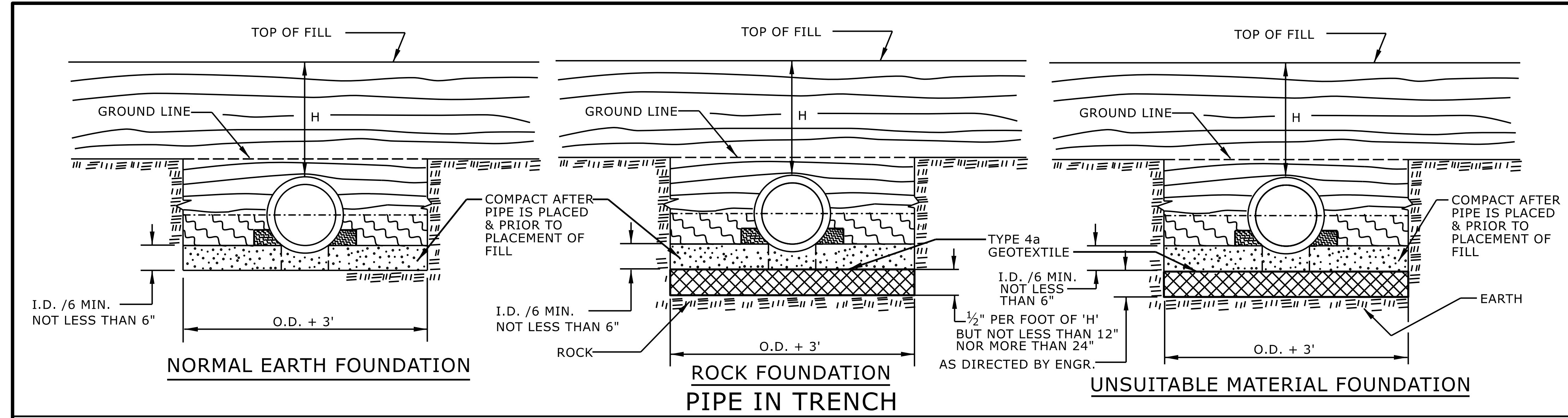
ORIGINAL BY: S.CALHOUN DATE: 7-25-2024  
 MODIFIED BY: DATE:  
 CHECKED BY: DATE:  
 FILE SPEC.: DATE:





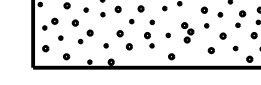

**GENERAL NOTES:**  
 I.D. = THE MAXIMUM HORIZONTAL INSIDE DIAMETER DIMENSION.  
 O.D. = THE MAXIMUM HORIZONTAL OUTSIDE DIAMETER DIMENSION.  
 H = THE FILL HEIGHT MEASURED VERTICALLY AT ANY POINT ALONG THE PIPE FROM THE TOP OF THE PIPE TO THE TOP OF THE EMBANKMENT AT THAT POINT.

-  APPROVED SUITABLE LOCAL MATERIAL.
-  TAKE CARE TO FULLY COMPACT HAUNCH ZONE OF PIPE BACKFILL.
-  LOOSELY PLACED SELECT MATERIAL CLASS III OR CLASS II, TYPE 1 FOR PIPE BEDDING. LEAVE SECTION DIRECTLY BENEATH PIPE UNCOMPACTED AS PIPE SEATING AND BACKFILL WILL ACCOMPLISH COMPACTION.

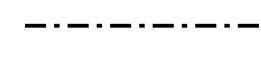
DO NOT OPERATE HEAVY EQUIPMENT OVER ANY PIPE CULVERT UNTIL THE PIPE CULVERT HAS BEEN PROPERLY BACKFILLED AND COVERED WITH AT LEAST 3 FEET OF APPROVED MATERIAL.

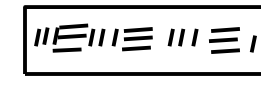
REFER TO NCDOT PIPE MATERIAL SELECTION GUIDE AND STANDARD SPECIFICATIONS FOR ALLOWABLE PIPE FILL HEIGHTS AND PIPE SPECIFICATIONS.

-  SPRINGLINE OF PIPE
-  SELECT BACKFILL MATERIAL CLASS III OR CLASS II, BELOW SPRINGLINE.
-  UNDISTURBED EARTH MATERIAL
-  SELECT MATERIAL CLASS V OR VI FOR FOUNDATION CONDITIONING. ENCAPSULATE WITH TYPE IV GEOTEXTILE AS DIRECTED BY THE ENGINEER.

STATE OF NORTH CAROLINA  
 DEPT. OF TRANSPORTATION  
 DIVISION OF HIGHWAYS  
 RALEIGH, N.C.  
 ROADWAY DETAIL DRAWING FOR  
**METHOD OF PIPE INSTALLATION**  
 RIGID PIPE

SHEET 2 OF 2  
**300.01**

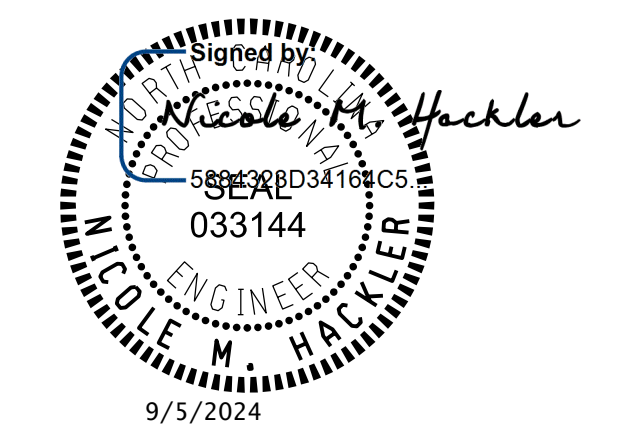

DOCUMENT NOT CONSIDERED FINAL UNLESS ALL SIGNATURES COMPLETED

**CONTRACTS STANDARDS AND DEVELOPMENT UNIT**  
 Office 919-707-6950 FAX 919-250-4119

**SEE TITLE BLOCK**

ORIGINAL BY: S.CALHOUN DATE: 7-25-2024  
 MODIFIED BY: DATE:  
 CHECKED BY: DATE:  
 FILE SPEC.:



PROJECT REFERENCE NO. <i>W-5601EX</i>	SHEET NO. <i>2D-1</i>
RW SHEET NO.	
HYDRAULICS ENGINEER Designed by: <i>Joshua G. Dalton</i> 26971 ENGINEER JOSHUA G. DALTON 9/5/2024	
DOCUMENT NOT CONSIDERED FINAL UNLESS ALL SIGNATURES COMPLETED	

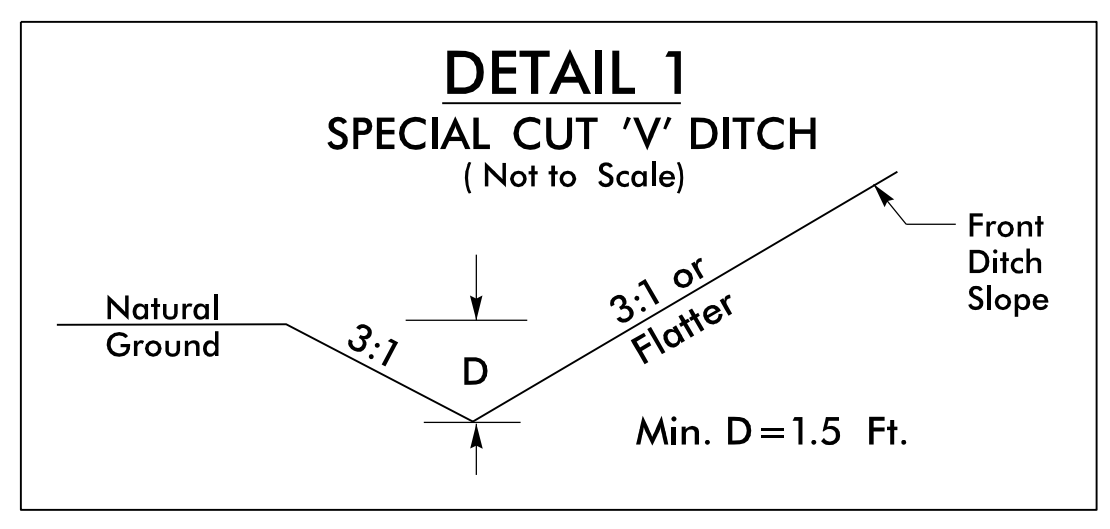

FROM STA. 10+00 -L- TO STA. 14+50 -L- RT  
 FROM STA. 19+00 -L- TO STA. 20+50 -L- LT  
 FROM STA. 20+50 -L- TO STA. 22+33 -L- LT  
 FROM STA. 21+50 -L- TO STA. 26+00 -L- RT

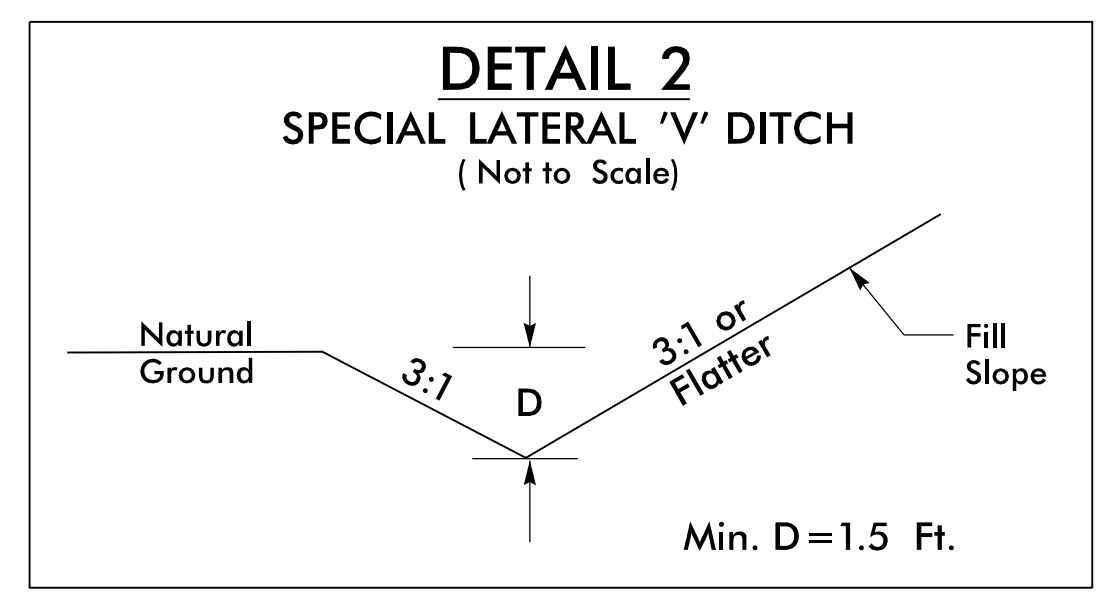

FROM STA. 10+00 -L- TO STA. 13+50 -L- LT

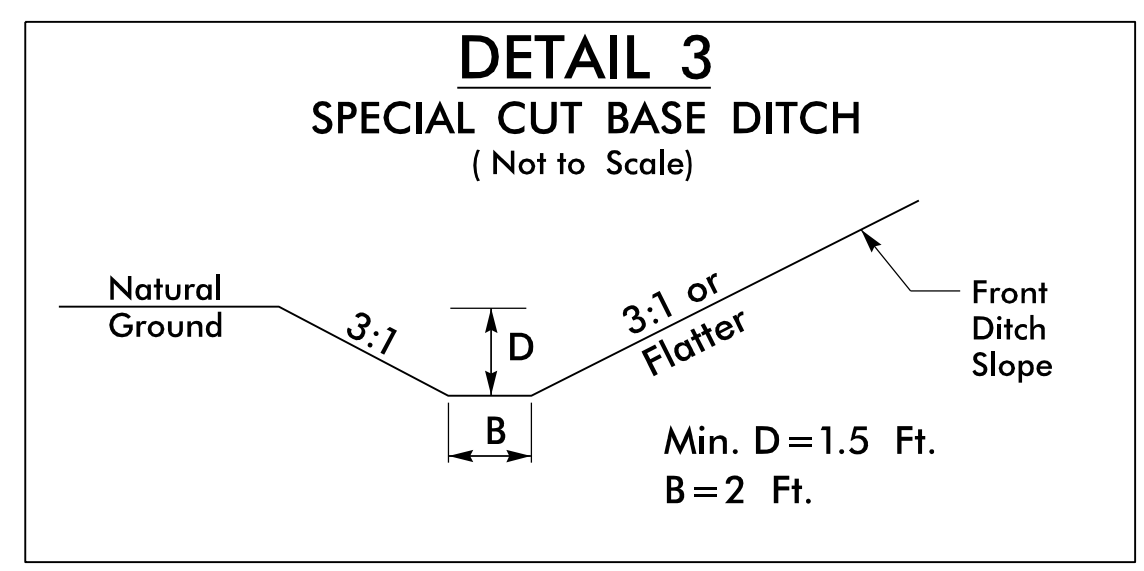

FROM STA. 14+25 -L- TO STA. 16+20 -L- LT

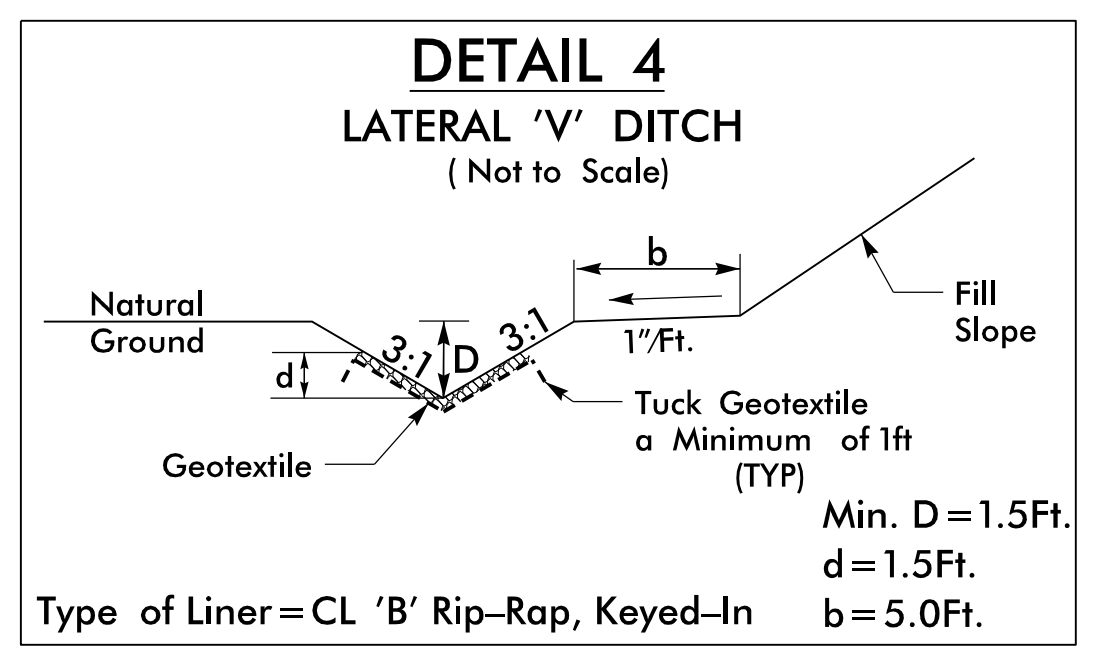

FROM STA. 16+50 TO STA. 17+20 -L- RT

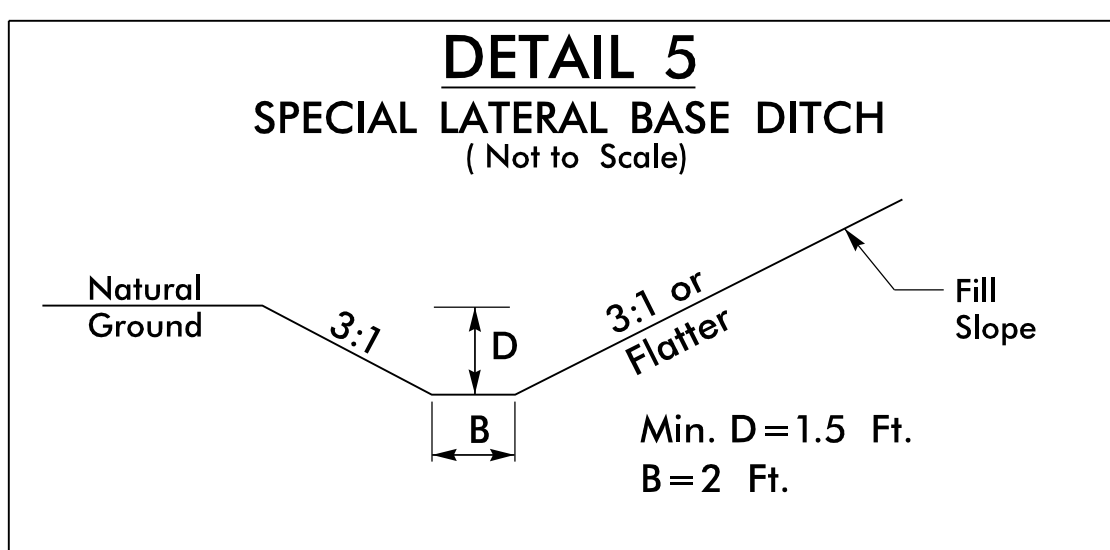

FROM STA. 16+70 -L- TO STA. 17+00 -L- LT  
 FROM STA. 17+00 -L- TO STA. 18+30 -L- LT

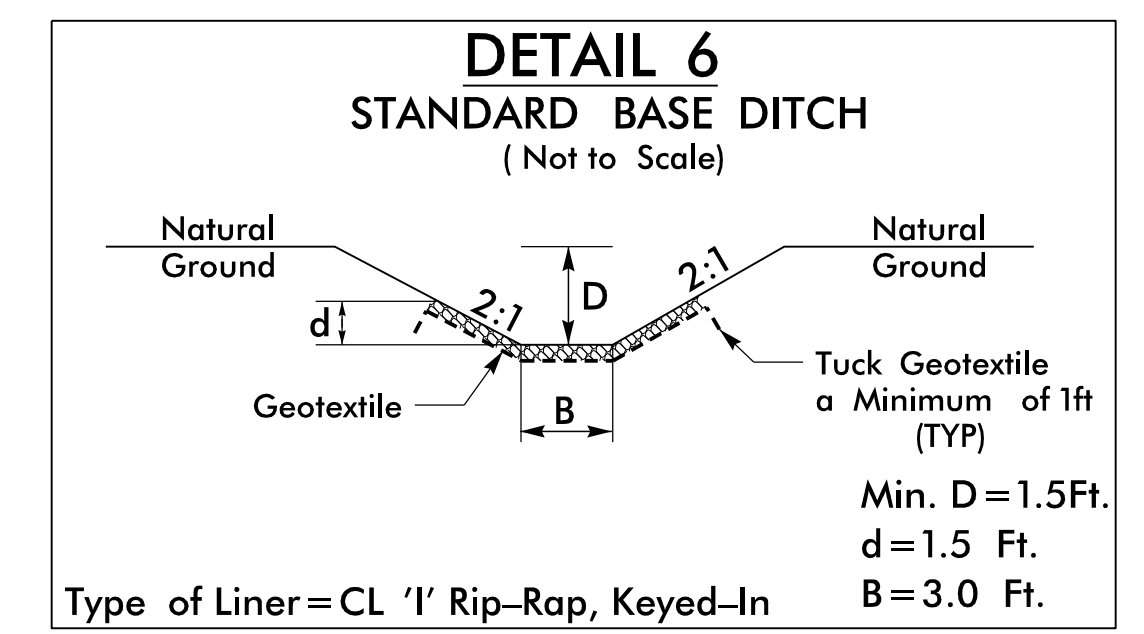

FROM STA. 17+15 -L- TO STA. 17+50 -L- RT

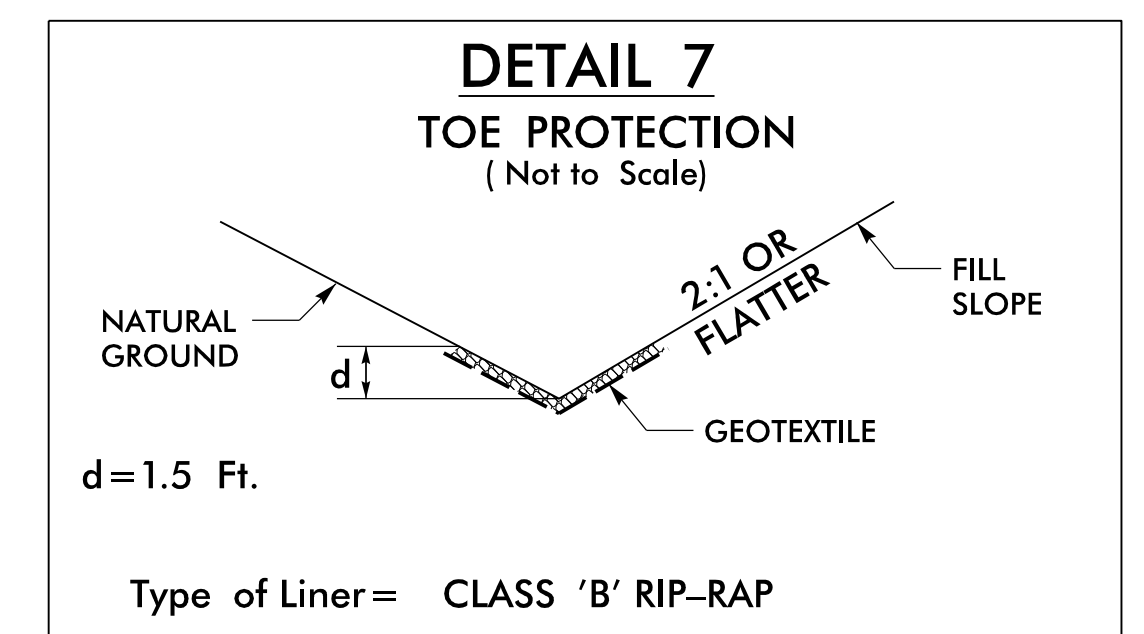

FROM STA. 17+20 -L- TO STA. 18+00 -L- RT

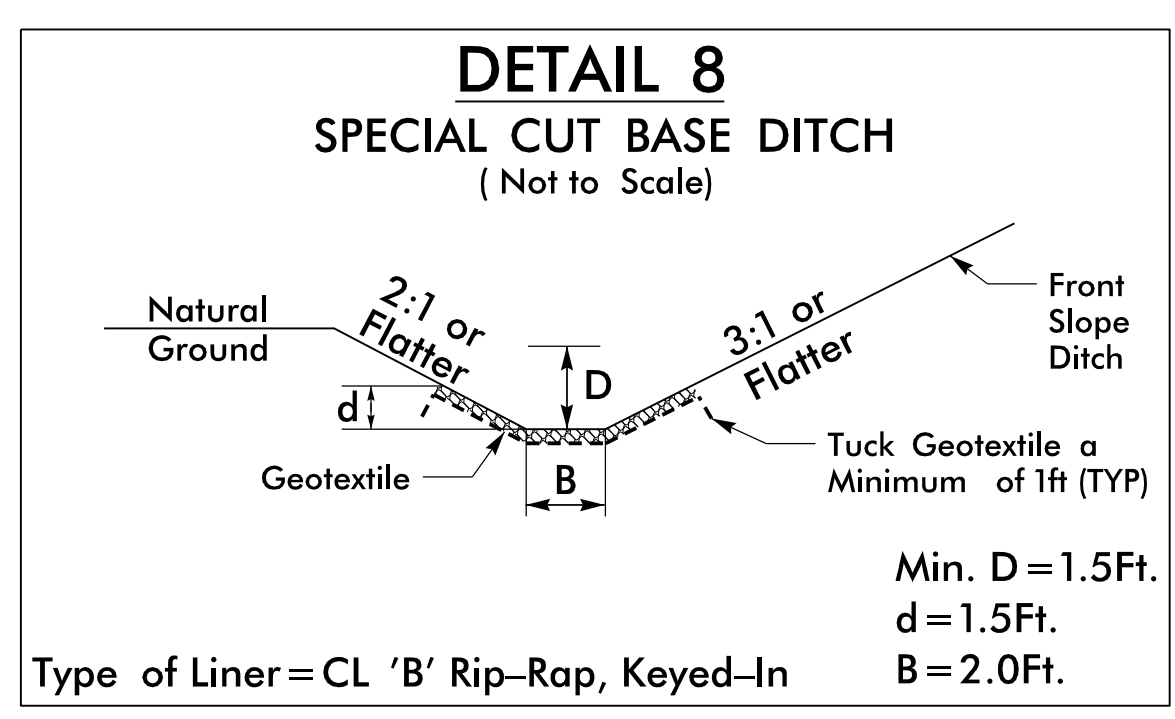

FROM STA. 23+30 -L- TO STA. 25+88 -L- LT  
 FROM STA. 26+68 -L- TO STA. 28+90 -L- LT

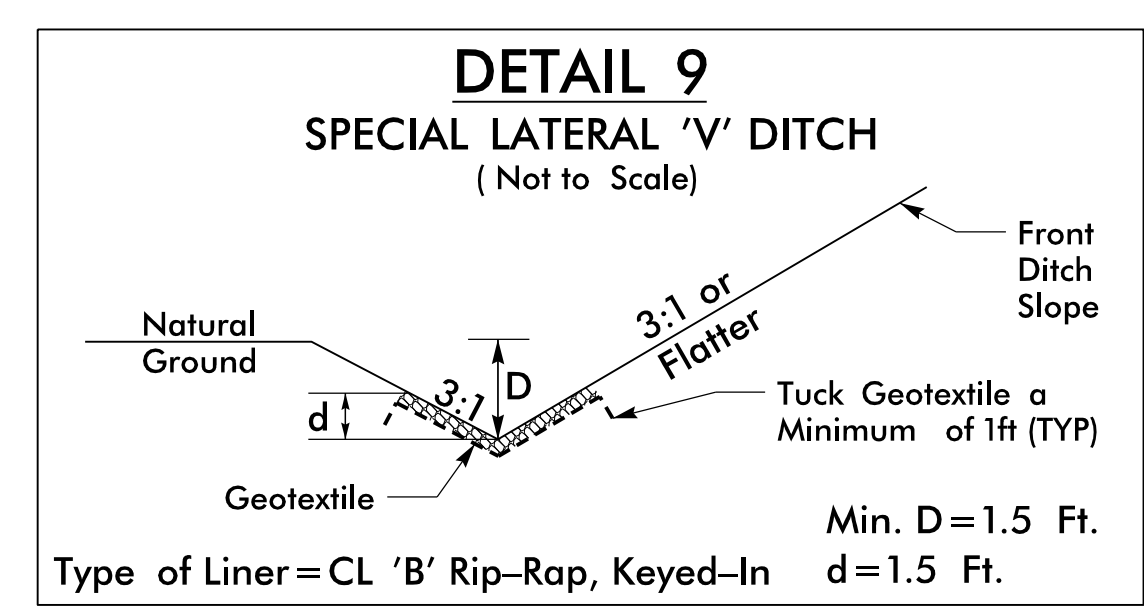

FROM STA. 14+50 -L- TO STA. 16+50 -L- RT

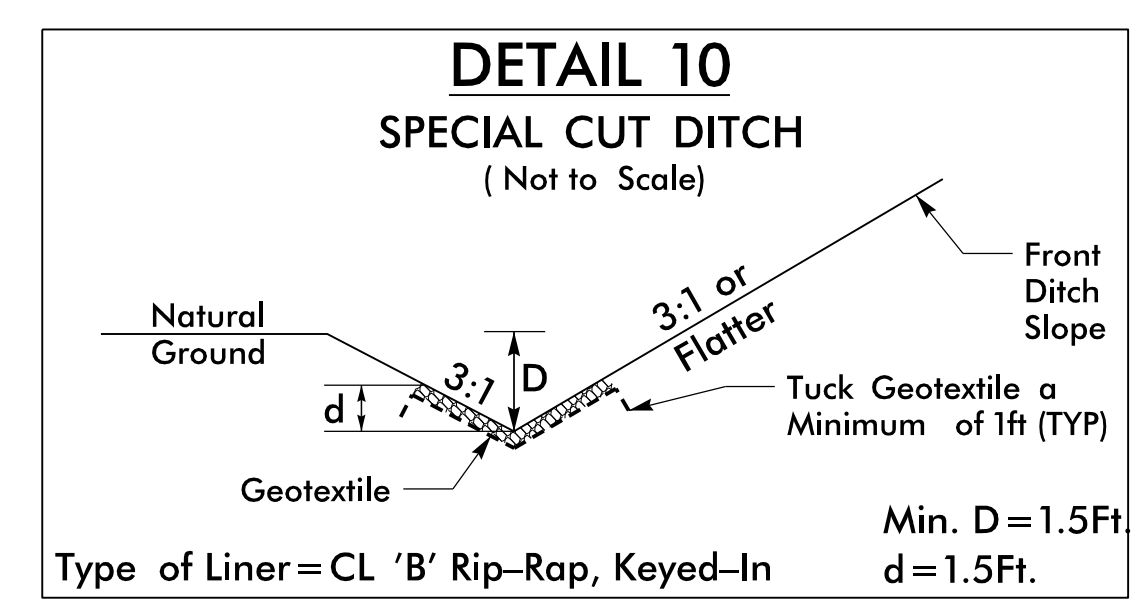

FROM STA. 22+33 -L- TO STA. 22+50 -L- LT



DIVISION OF HIGHWAYS  
 STATE OF NORTH CAROLINA

**SUMMARY OF EARTHWORK  
 IN CUBIC YARDS**

STATION	STATION	UNCL. EXCAV.	UNDERCUT EXCAV.	EMBANK. + %	BORROW	WASTE
-L- LT 10+00.00	13+65.00	346		146		200
-L- LT 14+05.00	18+50.00	1,103		310		793
-L- LT 18+85.00	22+90.00	667		12		655
-L- LT 23+15.00	26+05.00	1,743		5		1,738
-L- LT 26+50.00	30+35.00	1,581		11		1,570
SUBTOTAL:		5,440		484		4,956
-L- RT 10+00.00	20+30.00	739		734		5
-L- RT 21+10.00	30+35.00	1,190		91		1,099
SUBTOTAL:		1,929		825		1,104
TOTALS:		7,369		1,309		6,060
PROJECT TOTAL:		7,369		1,309		6,060
W-5601EX TOTAL:		7,369				6,060
W-5601EX SAY:		7,400				6,100
W-5601EY SAY:		1,800			2,500	
WASTE IN LIEU OF BORROW:					-2,500	-2,500
GRAND TOTAL:		9,200				3,600

EST. DDE W-5601EX = 200 CY  
 SHALLOW UNDERCUT = 150 CY  
 CLASS IV STABILIZATION = 300 TONS  
 SHOULDER BORROW = 1,050 CY (COVERED WITH LUMP SUM GRADING)

Note: Approximate quantities only. Unclassified Excavation, Fine Grading, Shoulder Borrow, and Clearing and Grubbing will be paid for at the contract lump sum price for "Grading."

**PARCEL INDEX SHEET**

PARCEL NO.	SHEET NO.	PROPERTY OWNER NAME
1	4	ANNIE LOU HOBBY BAGWELL
2	4	SON LAN FAIRWAY DEVELOPMENT COMPANY INC
2A	5	SON LAN FAIRWAY DEVELOPMENT COMPANY INC
3	4	JAMES ODOM
3A	4	DAVID A. EDSALL AND COLEY L. EDSALL
4	4	RICHARD S. GULLEY
4A	4	PETER THOMAS
5	4	CRANSTON LAMONT BASS, IVY J. BASS
6	4	MARY ELIZABETH LEE
7	4	JIMMY G. & MICHELE H. JARVIS
8	4	JEFFERY SCOTT ROWLAND; MARY JO WILSON
9	4	LINDA M. JACKSON; DOUGLAS JACKSON
10	5	CHRISTOPHER MACKER
11	5	WAYNE E. STEWART
12	5	PHAN, HIEP V.; TRAM TRUONG

4.004.006

IO:SEP-2024 14:22  
 W:\5601EX\Roadway\Proj\W-5601EX\_Rdy\_3B1.dgn  
 USER:NAME





8/17/99

PROJECT REFERENCE NO. W-5601EX	SHEET NO. 4
RW SHEET NO.	
ROADWAY DESIGN ENGINEER BRYAN E. DALTON	HYDRAULICS ENGINEER JOSHUA G. DALTON
DOCUMENT NOT CONSIDERED FINAL UNLESS ALL SIGNATURES COMPLETED	

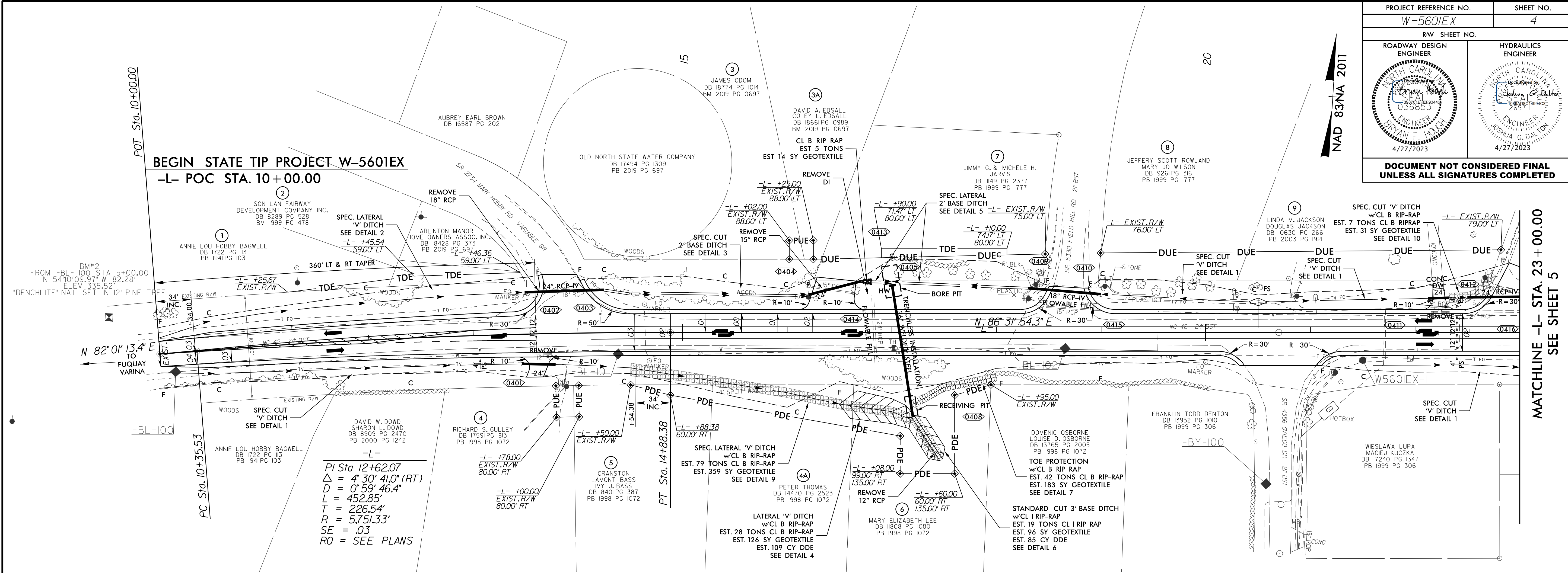

BM #2 "BENCLITE" NAIL IN 12" PINE  
 -L- STA. 10+13.66 (18.20' RT)  
 N 54° 10'09.97" W 82.28'  
 ELEV. 335.52'

BEGIN CONSTRUCTION  
 -L- STA. 10+00.00  
 EXIST. ELEV.

-L-  
 (NC 42)

PIPE HYDRAULIC DATA  
 36" WSP & RCP-IV Sta. 17+08

DRAINAGE AREA	= 6.7	AC
DESIGN FREQUENCY	= 50	YRS
DESIGN DISCHARGE	= 28	CFS
DESIGN HW ELEVATION	= 319.5	FT
100 YEAR DISCHARGE	= 30	CFS
100 YEAR HW ELEVATION	= 319.6	FT
OVERTOPPING FREQUENCY	= 500+	YRS
OVERTOPPING DISCHARGE	= 94	CFS
OVERTOPPING ELEVATION	= 324.7	FT

LEFT DITCH	-----
RIGHT DITCH	-----

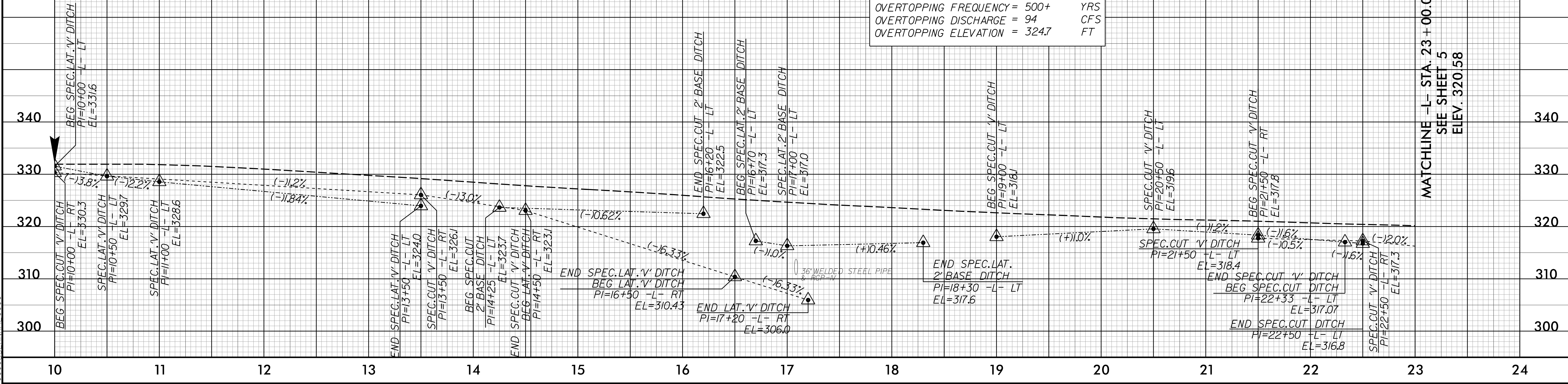

MATCHLINE -L- STA. 23+00.00  
 SEE SHEET 5  
 ELEV. 320.58

06-FEB-2023 17:44  
 M:\2013\23\3335\04 NCDOT W-5601EX\Roadway\Proj\W-5601EX\_Rdwy\_psh\_4.dgn  
 03:51:58 (1:51:58)



8/17/99

PROJECT REFERENCE NO. <b>W-5601EX</b>	SHEET NO. <b>5</b>
RW SHEET NO.	
ROADWAY DESIGN ENGINEER 	HYDRAULICS ENGINEER 
<b>DOCUMENT NOT CONSIDERED FINAL UNLESS ALL SIGNATURES COMPLETED</b>	

NAD 83/NA 2011

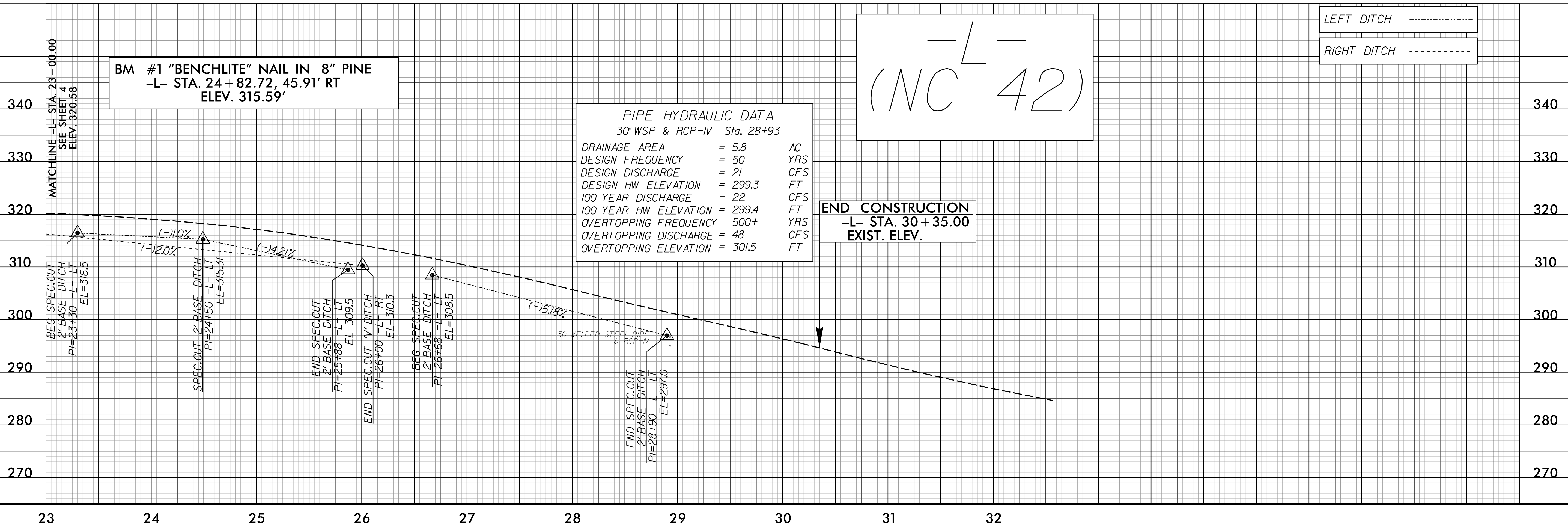
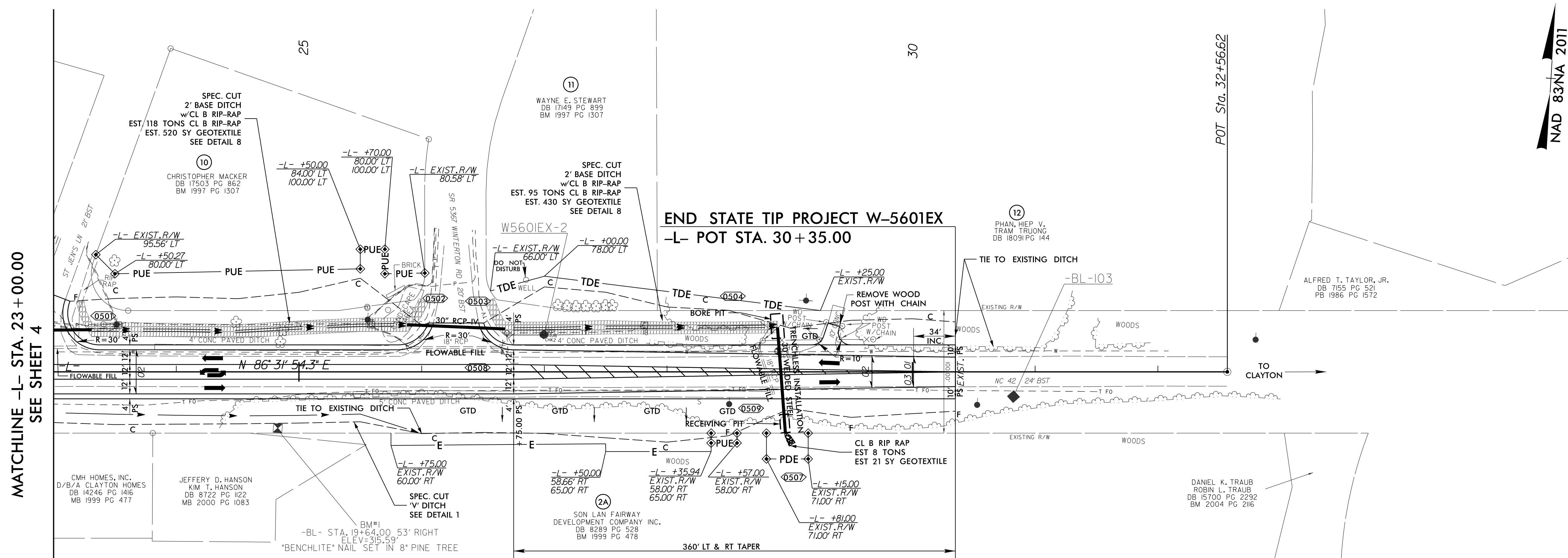

05-FEB-2023 2:40:31  
 M:\2013\2133395\_04 NCDOT W-5601EX\Roadway\Proj\W-5601EX\_Rdy\_psh\_5.dgn  
 8/17/99