

18 CHANNEL IP CONFLICT MONITOR

PROGRAMMING DETAIL

(remove jumpers and set switches as shown)

REMOVE DIODE JUMPERS 1-5, 1-6, 1-9, 1-11, 1-15, 1-17, 1-18, 2-5, 2-6, 2-11, 2-13, 2-15, 2-18, 3-7, 3-8, 3-9, 3-10, 3-12, 3-16, 4-7, 4-8, 4-9, 4-10, 4-11, 4-12, 4-14, 4-16, 5-9, 5-11, 5-13, 5-17, 5-18, 6-9, 6-13, 6-15, 6-17, 7-10, 7-11, 7-12, 7-14, 8-9, 8-10, 8-11, 8-12, 8-14, 8-16, 9-10, 9-11, 9-12, 9-14, 9-15, 9-16, 9-17, 9-18, 10-11, 10-12, 10-14, 10-16, 11-12, 11-13, 11-14, 11-16, 11-17, 11-18, 12-14, 12-16, 13-15, 13-18, 14-16, 15-17 and 17-18.

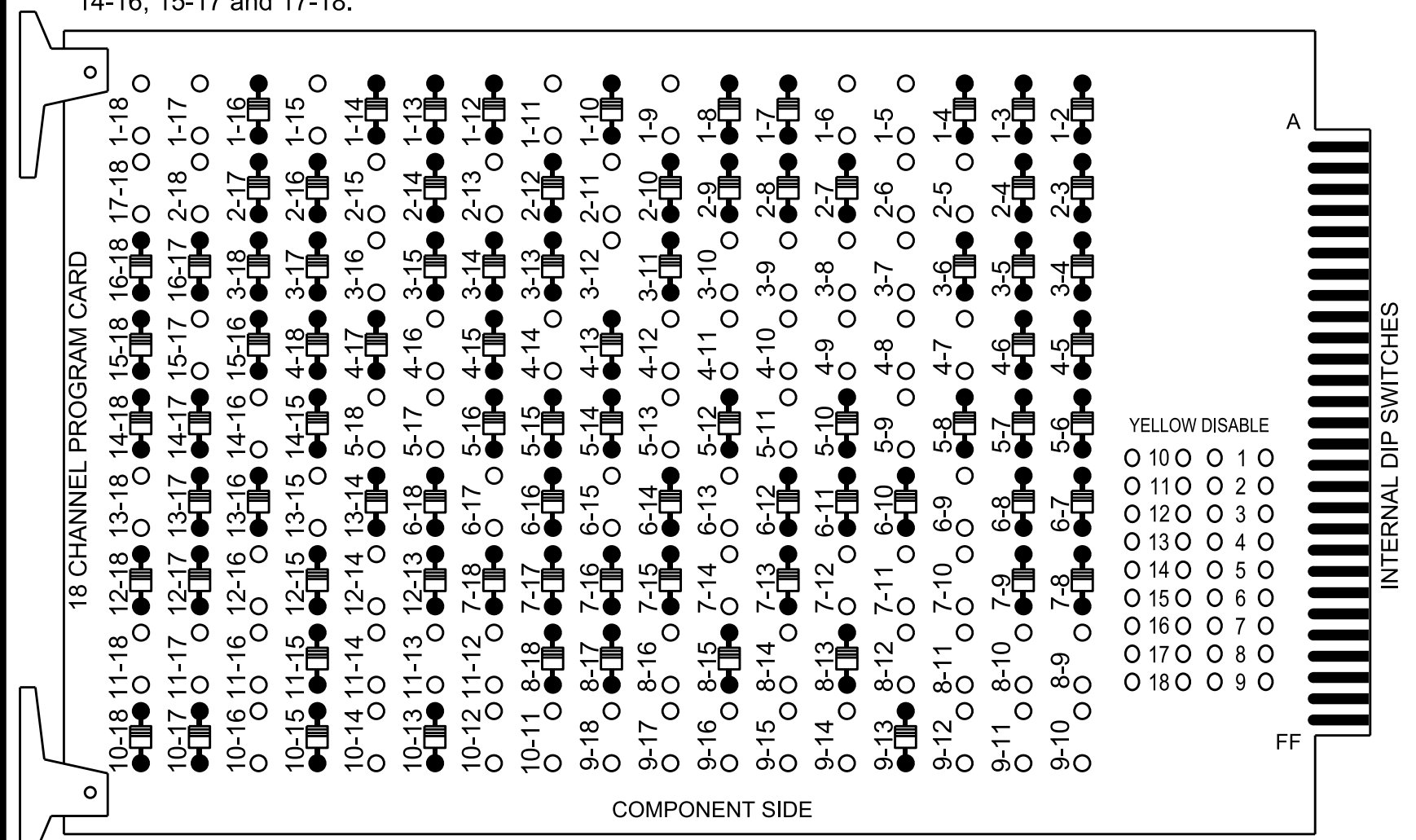

REMOVE JUMPERS AS SHOWN

NOTES:

- Card is provided with all diode jumpers in place. Removal of any jumper allows its channels to run concurrently.
- Ensure jumpers SEL2-SEL5 and SEL9 are present on the monitor board.
- Ensure that the Red Enable is active at all times during normal operation.
- Integrate monitor with Ethernet network in cabinet.

NOTES

- To prevent "flash-conflict" problems, insert red flash program blocks for all unused vehicle load switches in the output file. The installer shall verify that signal heads flash in accordance with the signal plan.
- Program phases 4 and 8 for Dual Entry.
- Program controller to start up in phase 2 Green No Walk and 6 Green No Walk.
- If this signal will be managed by an ATMS software, enable controller and detector logging for all detectors used at this location.
- The cabinet and controller are part of the (US 401 Closed Loop System #29) Signal System #: D05-09_Garner.

EQUIPMENT INFORMATION

Controller.....2070LX
 Cabinet.....332 w/ Aux
 Software.....Q-Free MAXTIME
 Cabinet Mount.....18 With Aux. Output File
 Load Switches Used.....S1, S2, S3, S4, S5, S6, S7, S8, S9, S10, S11, S12, AUX S1, AUX S2, AUX S3, AUX S4, AUX S5, AUX S6
 Phases Used.....1, 2, 3, 4, 5, 6, 7, 8, *9
 Overlap "1".....*
 Overlap "2".....*
 Overlap "3".....*
 Overlap "4".....*
 Overlap "5".....*
 Overlap "6".....*
 Overlap "7".....*
 Overlap "8".....*

*See overlap programming detail on Sheet 2.

SIGNAL HEAD HOOK-UP CHART

LOAD SWITCH NO.	S1	S2	S3	S4	S5	S6	S7	S8	S9	S10	S11	S12	AUX S1	AUX S2	AUX S3	AUX S4	AUX S5	AUX S6	
CMU CHANNEL NO.	1	2	13	3	4	14	5	6	15	7	8	16	9	10	17	11	12	18	
PHASE	OL7	2	2 PED	3	4	4 PED	5	OL8	6 PED	7	8	8 PED	OL1	OL2	OL5	OL3	OL4	OL6	
SIGNAL HEAD NO.	83	21,22	P21, P22	22	31	41,42	P41, P42	43	61,62	P61, P62	71	81,82	P81, P82	83	31	11,12	43	71	51,52
RED		128		*		101		134			107		A121					A114	
YELLOW	*	129				102		135		*	108								
GREEN		130				103		136			109								
RED ARROW															A124	A124		A101	A124
YELLOW ARROW				117									A122	A125	A125	A115	A102	A125	
FLASHING YELLOW ARROW													A123	A126		A116	A103		
GREEN ARROW	127			118	118			133			124				124				124
Hand			113					104			119		110						
Walking Person								106			121		112						

NU = Not Used
 * Denotes install load resistor. See load resistor installation detail this sheet.
 * See pictorial of head wiring in detail this sheet.

INPUT FILE POSITION LAYOUT

(front view)

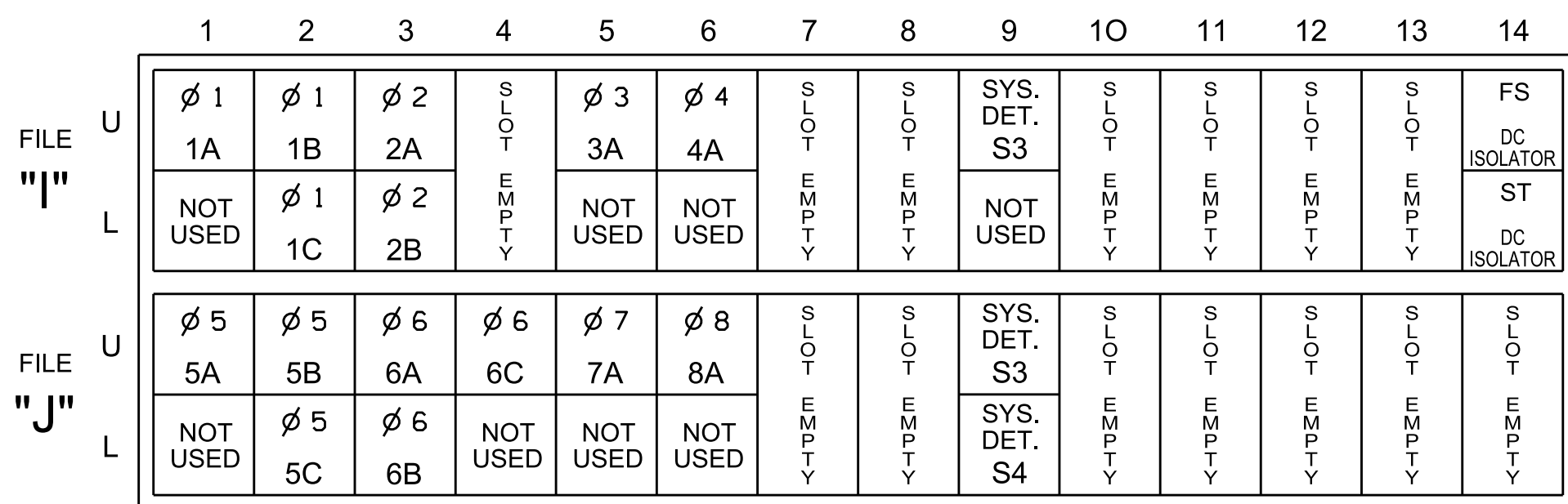

EX. : 1A, 2A, ETC. = LOOP NO.'S

FS = FLASH SENSE
 ST = STOP TIME

INPUT FILE CONNECTION & PROGRAMMING CHART

LOOP NO.	LOOP TERMINAL	INPUT FILE POS.	PIN NO.	INPUT POINT	DETECTOR NO.	CALL PHASE	DELAY TIME	EXTEND TIME	EXTEND	ADDED INITIAL	CALL	DELAY DURING GREEN
1A	TB2-1,2	I1U	56	18	1	1/9			X		X	
1B	TB2-5,6	I2U	39	1	2	1/9			X		X	
1C	TB2-7,8	I2L	43	5	3	1	15		X		X	
2A	TB2-9,10	I3U	63	29	4	2			X	X	X	
2B	TB2-11,12	I3L	76	42	5	2			X	X	X	
3A	TB4-5,6	I6U	58	20	7	3	15		X		X	
4A	TB4-9,10	I6U	41	3	8	4			X		X	
*S5	TB6-9,10	I9U	60	22	13	SYS			X		X	
5A	TB3-1,2	J1U	55	17	15	5			X		X	
5B	TB3-5,6	J2U	40	2	16	5			X		X	
5C	TB3-7,8	J2L	44	6	17	5	15		X		X	
6A	TB3-9,10	J3U	64	30	18	6			X		X	
6B	TB3-11,12	J3L	77	43	19	6			X		X	
6C	TB5-1,2	J4U	48	10	20	6			X		X	
7A	TB5-5,6	J5U	57	19	21	7	15		X		X	
8A	TB5-9,10	J6U	42	4	22	8			X		X	
*S3	TB7-9,10	J9U	59	21	27	SYS			X		X	
*S4	TB7-11,12	J9L	61	23	28	SYS			X		X	

*System detector only. Remove any assigned vehicle phase.

INPUT FILE POSITION LEGEND: J2L

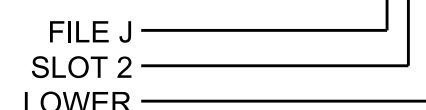

FYA SIGNAL WIRING DETAIL

(wire signal heads as shown)

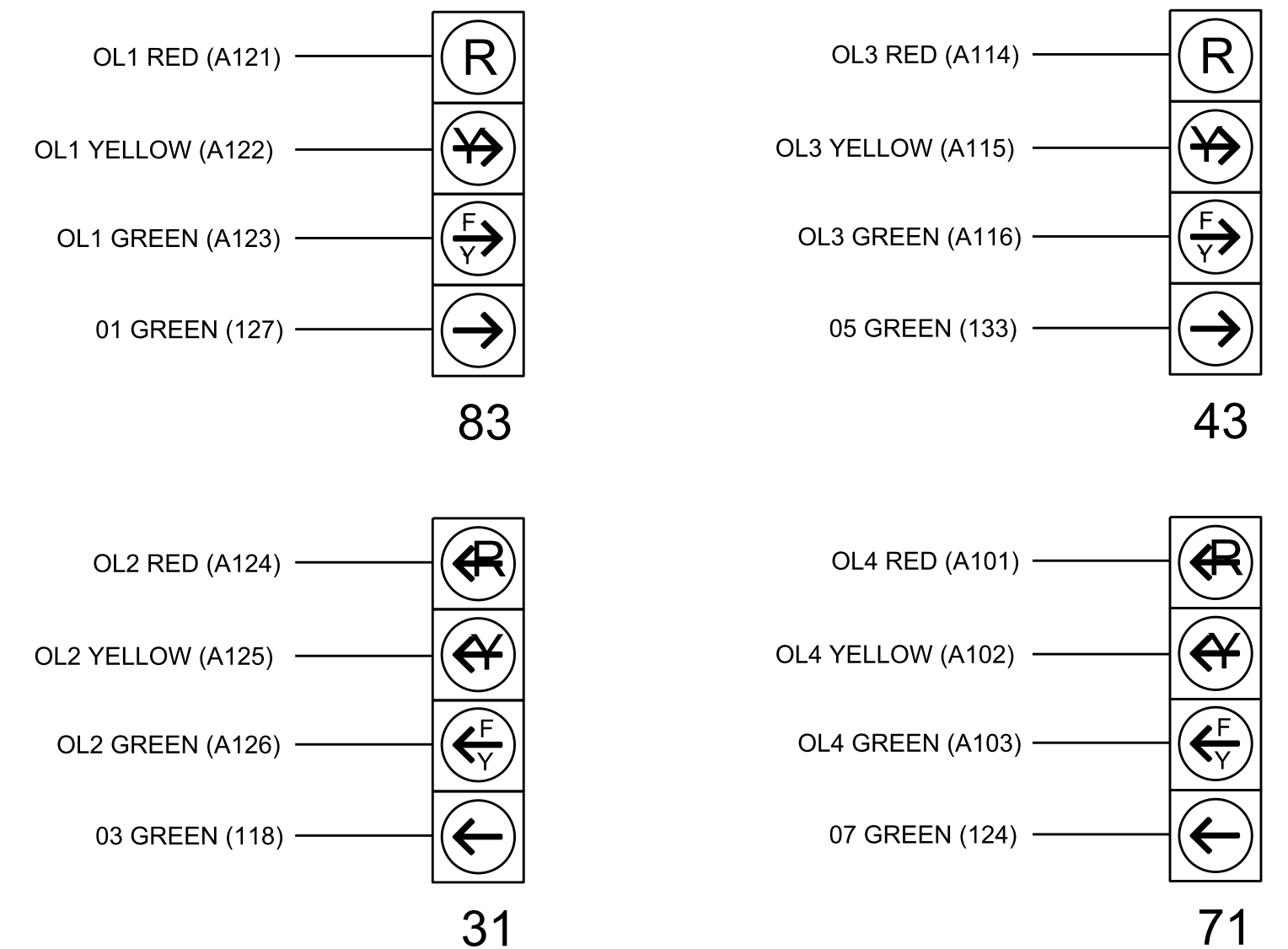

THIS ELECTRICAL DETAIL IS FOR THE SIGNAL DESIGN: 05-0184
 DESIGNED: July 2024
 SEALED: 8-12-24
 REVISED: N/A

LOAD RESISTOR INSTALLATION DETAIL

(install resistors as shown)

Value (ohms)	Wattage
1.5K - 1.9K	25W (min)
2.0K - 3.0K	10W (min)

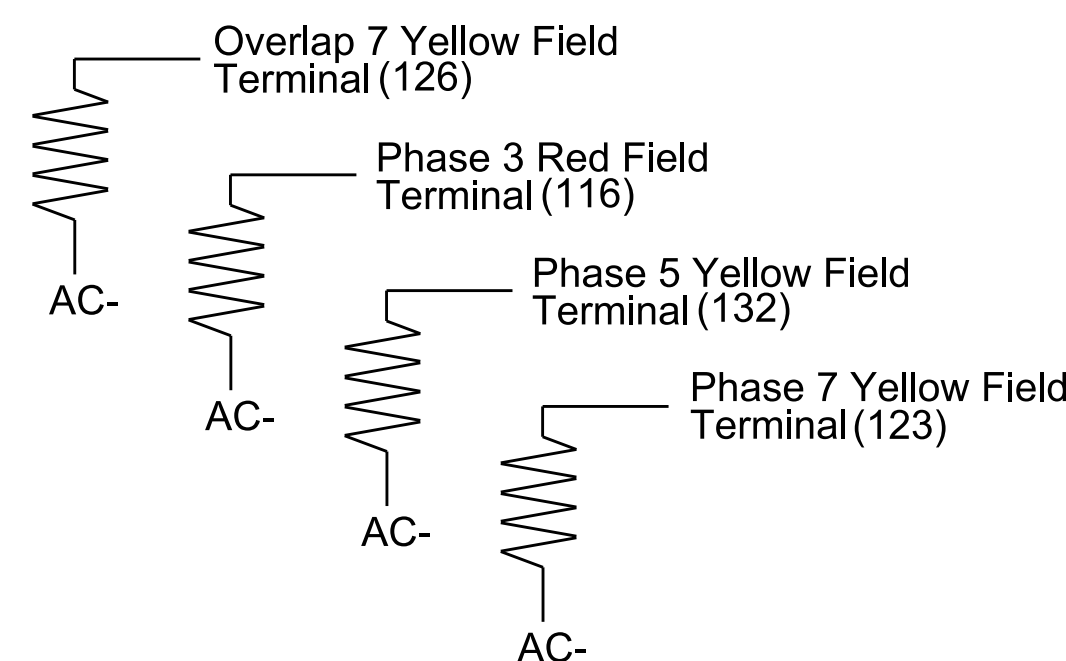

COUNTDOWN PEDESTRIAN SIGNAL OPERATION

Countdown Ped Signals are required to display timing only during Ped Clearance Interval. Consult Ped Signal Module user's manual for instructions on selecting this feature.

Electrical Detail - Sheet 1 of 3

Prepared in the Offices of:
 Transportation Mobility and Safety Division
 STATE OF NORTH CAROLINA
 DEPARTMENT OF TRANSPORTATION
 Signal Management Section

US 401 (Fayetteville Rd.)
 at
 SR 1010 (Ten-Ten Rd.)

Division 5 Wake County Fuquay-Varina

PLAN DATE: August 2024 REVIEWED BY: -
 PREPARED BY: James Peterson REVIEWED BY: -

REVISIONS: INIT. DATE

Signed by: Ryan W. Houff 08/13/2024
 430320FAA2654C3 DATE

DOCUMENT NOT CONSIDERED FINAL UNLESS ALL SIGNATURES COMPLETED

SEAL
 NORTH CAROLINA PROFESSIONAL ENGINEER
 SEAL 036833
 RYAN W. HOUFF

750 N. Greenfield Pkwy, Garner, NC 27529
 SIG. INVENTORY NO. 05-0184