

### 18 CHANNEL CONFLICT MONITOR PROGRAMMING DETAIL

(remove jumpers and set switches as shown)

REMOVE DIODE JUMPERS 1-5, 1-6, 1-9, 1-11, 2-5, 2-6, 2-9, 2-11, 4-8, 4-12, 5-9, 5-11, 6-9, 6-11, 8-12, AND 9-11.

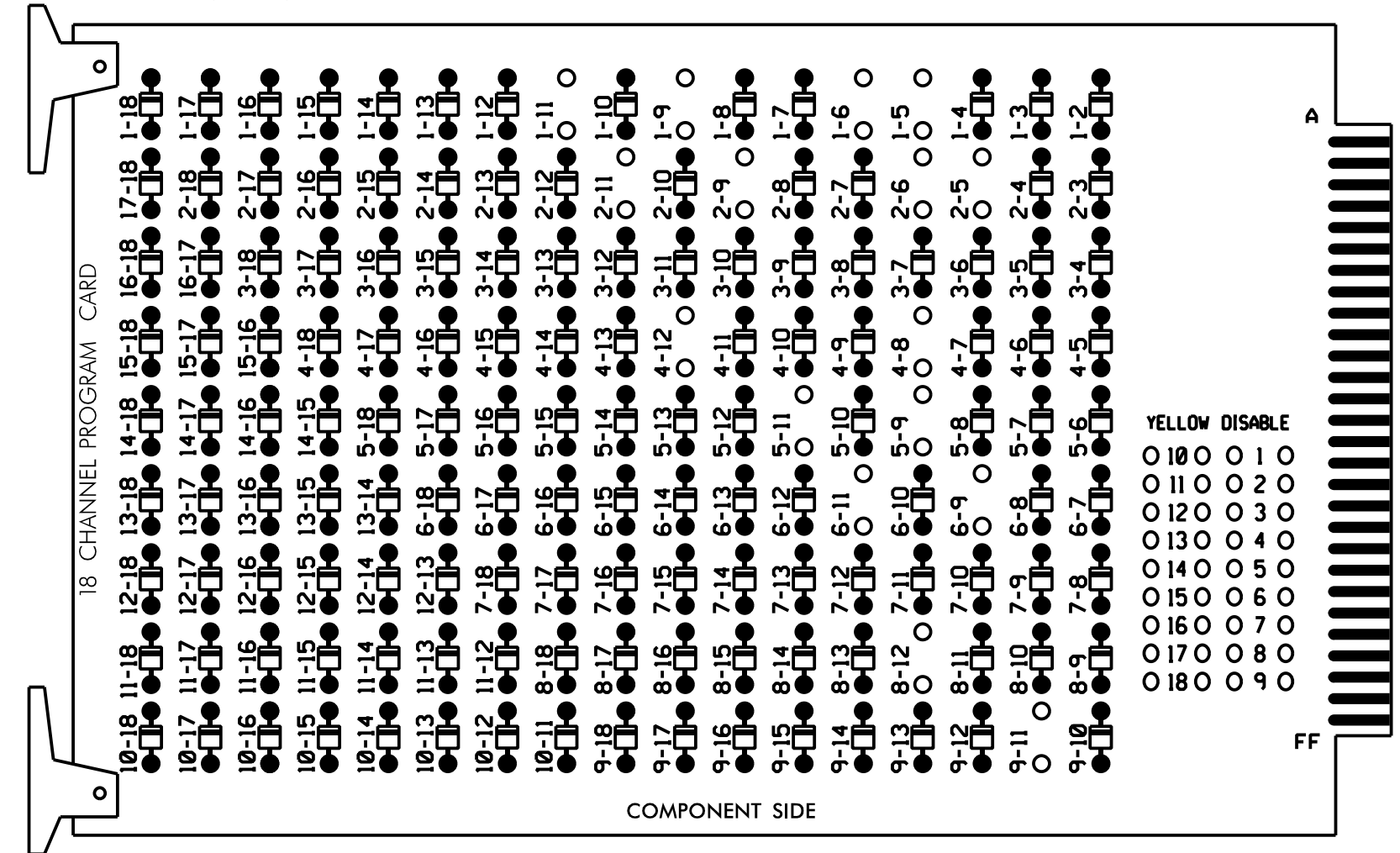

REMOVE JUMPERS AS SHOWN

NOTES:

- 1. Card is provided with all diode jumpers in place. Removal of any jumper allows its channels to run concurrently.
2. Ensure jumpers SEL2-SEL5 are present on the monitor board.
3. Ensure that Red Enable is active all times during normal operation.
4. Connect serial cable from conflict monitor to comm. port 1 of 2070 controller. Ensure conflict monitor communicates with 2070.

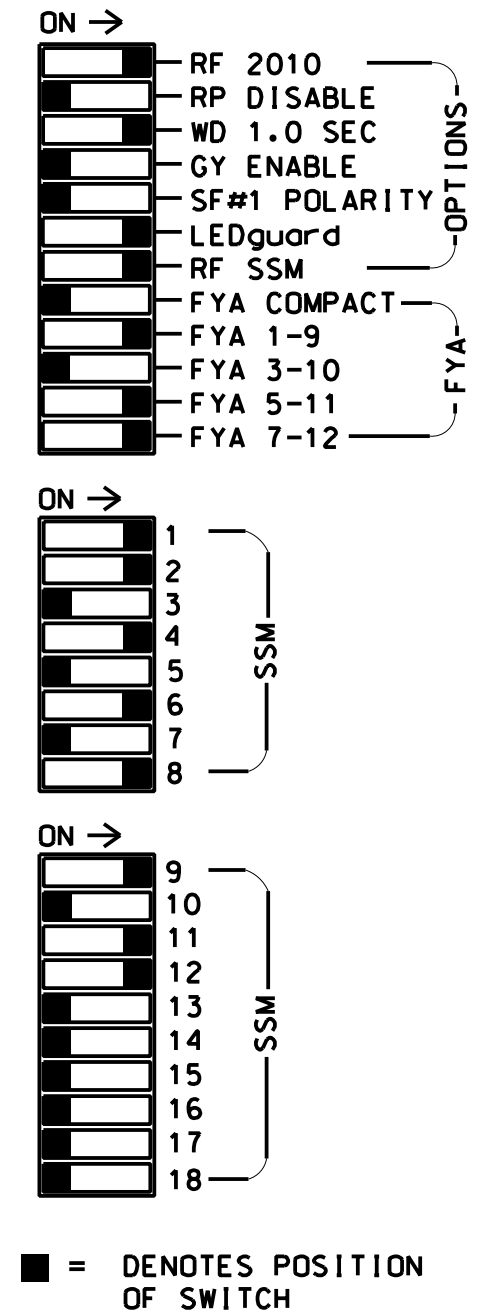
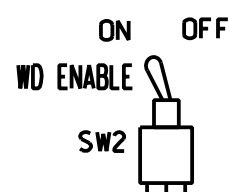

### NOTES

- 1. To prevent "flash-conflict" problems, insert red flash program blocks for all unused vehicle load switches in the output file. The installer shall verify that signal heads flash in accordance with the Signal Plans.
2. Program phases 4 and 8 for Dual Entry.
3. Enable Simultaneous Gap-Out for all Phases.
4. Program phases 2 and 6 for Startup In Green.
5. Program phases 2 and 6 for Yellow Flash, and overlap 1 as Wag Overlap.
6. The cabinet and controller are part of the Wilmington Signal System.

### EQUIPMENT INFORMATION

CONTROLLER.....2070
CABINET.....332 W/ AUX
SOFTWARE.....ECONOLITE OASIS
CABINET MOUNT.....BASE
OUTPUT FILE POSITIONS...18 WITH AUX. OUTPUT FILE
LOAD SWITCHES USED.....S1,S2,S5,S7,S8,S11,AUX S1,
AUX S4, AUX S5
PHASES USED.....1,2,4,5,6,8
OVERLAP "A".....1+2
OVERLAP "B".....NOT USED
OVERLAP "C".....5+6
OVERLAP "D".....8

### SIGNAL HEAD HOOK-UP CHART

Table with columns for Load Switch No., CMU Channel No., Phase, Signal Head No., and various signal head types (RED, YELLOW, GREEN, RED ARROW, YELLOW ARROW, FLASHING YELLOW ARROW, GREEN ARROW) with corresponding values.

NU = Not Used
\* Denotes install load resistor. See load resistor installation detail this sheet.
★ See pictorial of head wiring in detail this sheet.

### INPUT FILE POSITION LAYOUT

(front view)

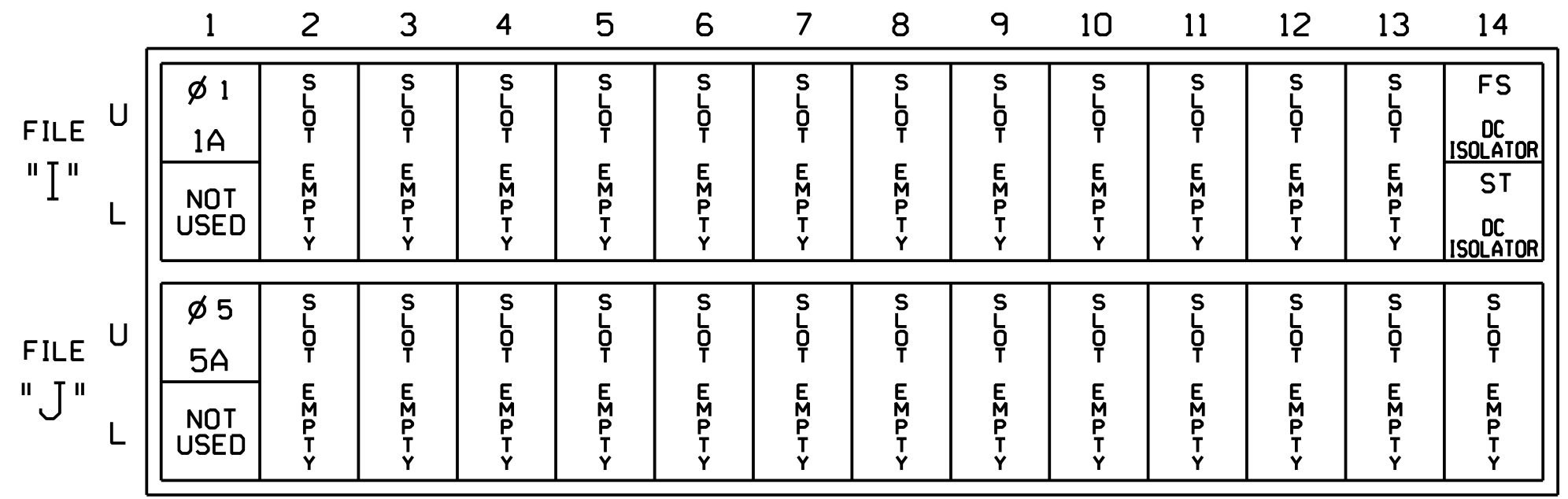

EX.: 1A, 2A, ETC. = LOOP NO.'S

FS = FLASH SENSE
ST = STOP TIME

### INPUT FILE CONNECTION & PROGRAMMING CHART

Table with columns: LOOP NO., LOOP TERMINAL, INPUT FILE POS., PIN NO., INPUT ASSIGNMENT NO., DETECTOR NO., NEMA PHASE, CALL, EXTEND, FULL TIME DELAY, STRETCH TIME, DELAY TIME. Includes rows for 1A and 5A.

\* See Input Page Assignment programming details on sheets 3 and 4.

#### INPUT FILE POSITION LEGEND: J2L

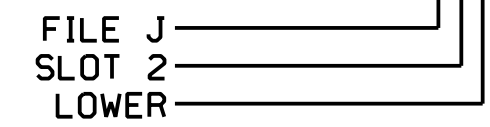

### FYA SIGNAL WIRING DETAIL

(wire signal heads as shown)

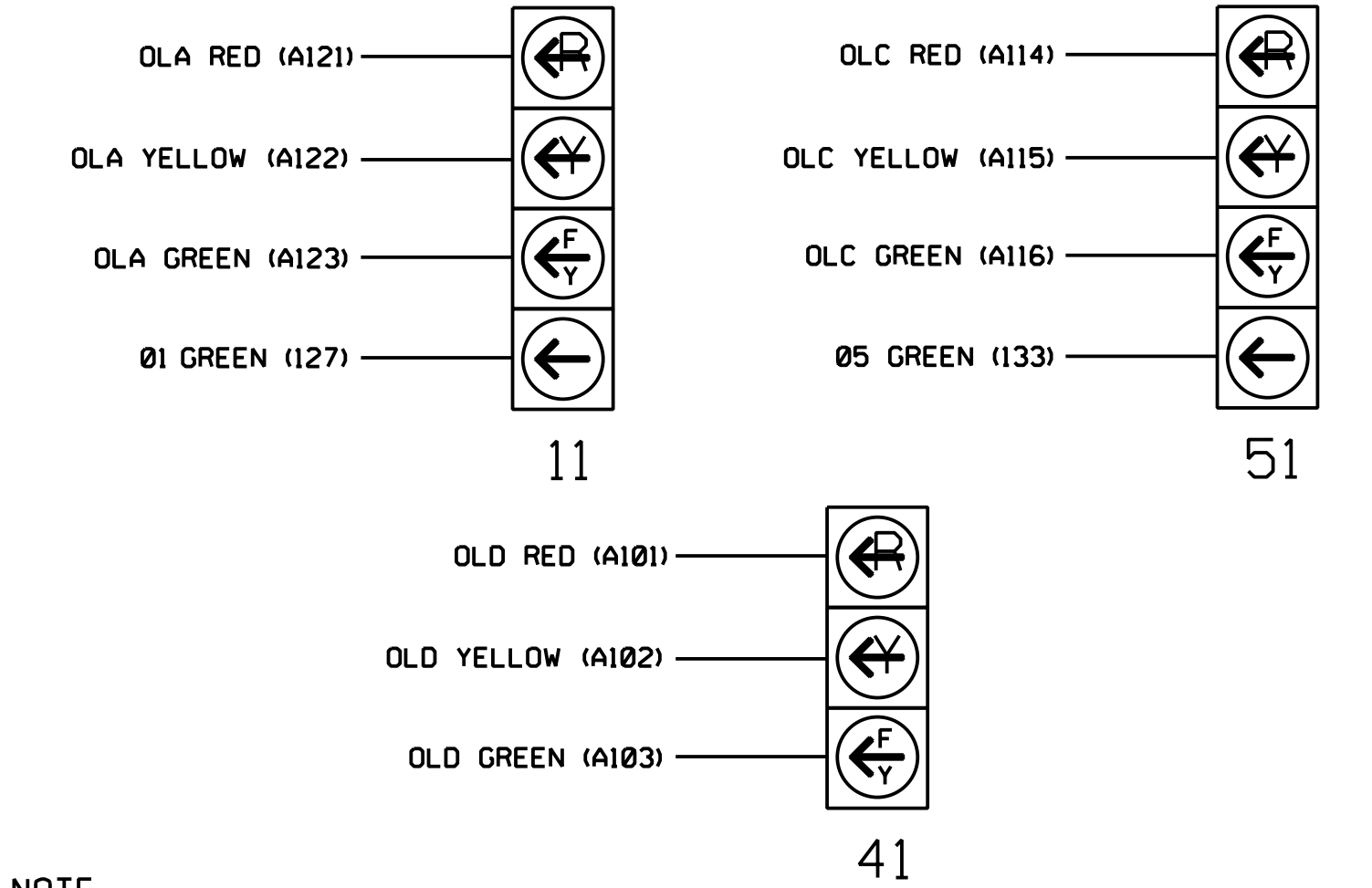

NOTE

The sequence display for signal heads 11 and 51 require special logic programming. See sheet 2 for programming instructions.

### LOAD RESISTOR INSTALLATION DETAIL

(install resistors as shown below)

Table with columns: VALUE (ohms), WATTAGE. Values: 1.5K - 1.9K, 25W (min); 2.0K - 3.0K, 10W (min).

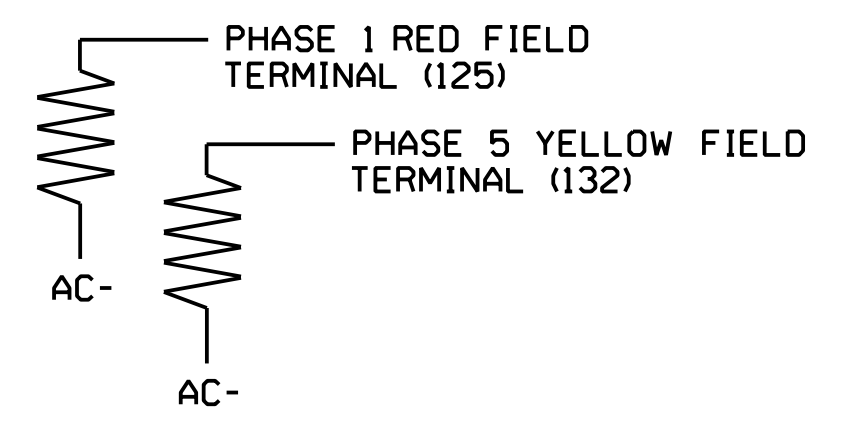

THIS ELECTRICAL DETAIL IS FOR THE SIGNAL DESIGN: 03-0847T2
DESIGNED: May 2022
SEALED: 5/17/2024
REVISED:



HNTB NORTH CAROLINA, P.C.
343 E. Six Forks Road, Suite 200
Raleigh, North Carolina 27609
NC License No: C-1554
(919) 546-8997

Signal Upgrade-
Electrical Detail - Sheet 1 of 5
(Construction Phase 2A)

DOCUMENT NOT CONSIDERED FINAL UNLESS ALL SIGNATURES COMPLETED

Professional seal and signature block for N.K. Vianich, E.E. Tiller, and N.R. Simmons, dated 5/17/2024.