

18 CHANNEL CONFLICT MONITOR PROGRAMMING DETAIL

(remove jumpers and set switches as shown)

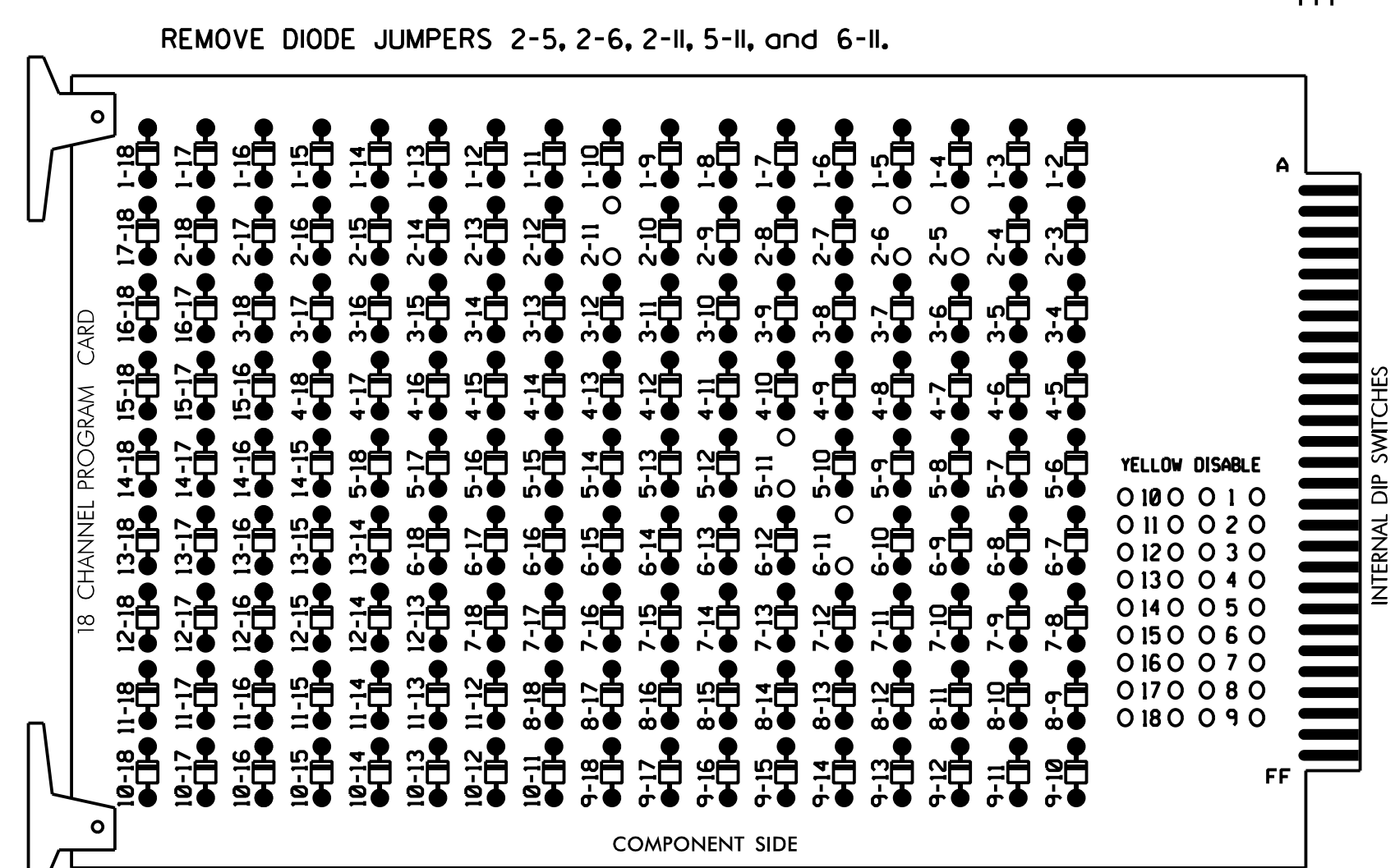

NOTES:

- Card is provided with all diode jumpers in place. Removal of any jumper allows its channels to run concurrently.
- Ensure jumpers SEL2-SEL5 are present on the monitor board.
- Ensure th Red Enable is active all times during normal operation.
- Connect serial cable from conflict monitor to comm. port 1 of 2070 controller. Ensure conflict monitor communicates with 2070.

NOTES

- To prevent "flash-conflict" problems, insert red flash program blocks for all unused vehicle load switches in the output file. The installer shall verify that signal heads flash in accordance with the Signal Plans.
- Enable Simultaneous Gap-Out for all Phases.
- Program phases 2 and 6 for Variable Initial and Gap Reduction.
- Program phases 2 and 6 for Startup in Green.
- Program phases 2 and 6 for Yellow Flash.
- The cabinet and controller are part of the Wilmington Signal System.

EQUIPMENT INFORMATION

CONTROLLER.....2070
 CABINET.....332 W/ AUX
 SOFTWARE.....ECONOLITE OASIS
 CABINET MOUNT.....BASE
 OUTPUT FILE POSITIONS...18 WITH AUX. OUTPUT FILE
 LOAD SWITCHES USED.....S2,S7,S8,S11,AUX S4
 PHASES USED.....2,5,6,8
 OVERLAP "A".....NOT USED
 OVERLAP "B".....NOT USED
 OVERLAP "C".....5+6
 OVERLAP "D".....NOT USED

SIGNAL HEAD HOOK-UP CHART

LOAD SWITCH NO.	S1	S2	S3	S4	S5	S6	S7	S8	S9	S10	S11	S12	AUX S1	AUX S2	AUX S3	AUX S4	AUX S5	AUX S6		
CMU CHANNEL NO.	1	2	13	3	4	14	5	6	15	7	8	16	9	10	17	11	12	18		
PHASE	1	2	2 PED	3	4	4 PED	5	6	6 PED	7	8	8 PED	OLA	OLB	SPARE	OLC	OLD	SPARE		
SIGNAL HEAD NO.	NU	21	22	NU	NU	NU	NU	51	61	62	NU	NU	81,82	83,84	NU	NU	NU	51	NU	
RED	128	128							134	134				107						
YELLOW	129	129						*	135	135										
GREEN	130									136										
RED ARROW													107						A114	
YELLOW ARROW														108	108					A115
FLASHING YELLOW ARROW																				A116
GREEN ARROW			130					133	136				109	109						
Hand icon																				
Person icon																				

NU = Not Used

* Denotes install load resistor. See load resistor installation detail this sheet.

★ See pictorial of head wiring in detail this sheet.

INPUT FILE POSITION LAYOUT

(front view)

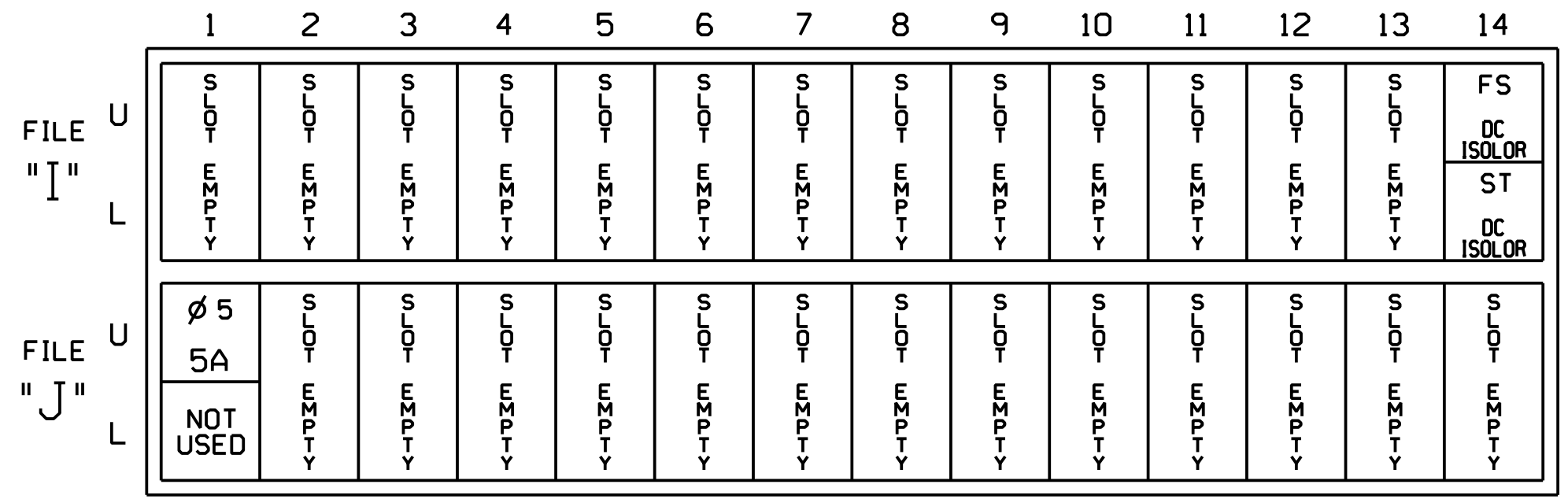

EX.: 1A, 2A, ETC. = LOOP NO.'S

FS = FLASH SENSE
ST = STOP TIME

INPUT FILE CONNECTION & PROGRAMMING CHART

LOOP NO.	LOOP TERMINAL	INPUT FILE POS.	PIN NO.	INPUT ASSIGNMENT NO.	DETECTOR NO.	NEMA PHASE	CALL	EXTEND	FULL TIME DELAY	STRETCH TIME	DELAY TIME
5A ¹	TB3-1,2	J1U	55	17	5	5	Y	Y			15
	-	14U	47	9 ★	22	2	Y	Y			3
	-	J1U	55	17 ★	55	5	Y	Y			3

* See Input Page Assignment programming details on sheet 3.

INPUT FILE POSITION LEGEND: J2L

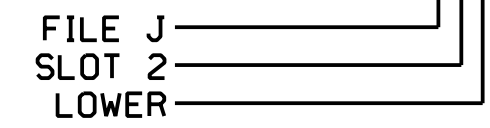

FYA SIGNAL WIRING DETAIL

(wire signal head as shown)

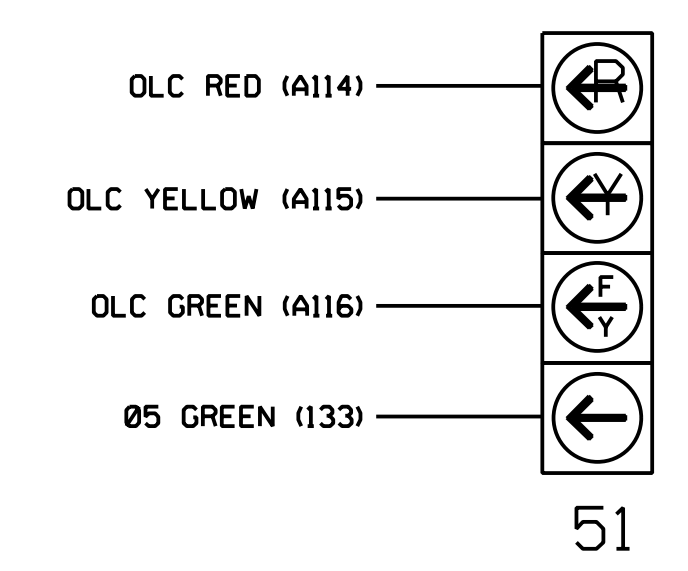

NOTE

The sequence display for signal head 51 requires special logic programming. See sheet 2 for programming instructions.

LOAD RESISTOR INSTALLATION DETAIL

(install resistor as shown below)

ACCEPTABLE VALUES	
VALUE (ohms)	WTAGE
1.5K - 1.9K	25W (min)
2.0K - 3.0K	10W (min)

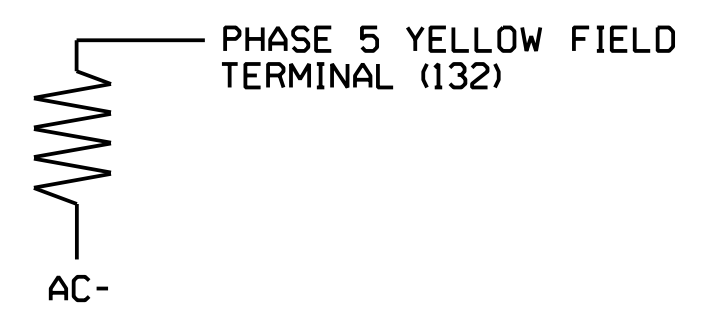

This plan supersedes the plan signed and sealed on 5/17/2024.

THIS ELECTRICAL DETAIL IS FOR THE SIGNAL DESIGN: 03-0258T2
 DESIGNED: May 2022
 SEALED: 5/17/2024
 REVISED:



HNTB NORTH CAROLINA, P.C.
 343 E. Six Forks Road, Suite 200
 Raleigh, North Carolina 27609
 NC License No: C-1554
 (919) 546-8997

Signal Upgrade-
 Electrical Detail - Sheet 1 of 4
 (Construction Phase 2)

DOCUMENT NOT CONSIDERED FINAL UNLESS ALL SIGNATURES COMPLETED

ELECTRICAL AND PROGRAMMING DETAILS FOR: Prepared in the Office of: 750 N. Greenfield Pkwy, Garner, NC 27529	SR 2048 (Gordon Rd)		SEAL SEAL 031464 ENGINEER NATASHA R. SIMMONS
	at I-40 WB Ramps		
Division 3 New Hanover County Wilmington PLAN DATE: August 2023 PREPARED BY: E.E. Tiller	REVIEWED BY: N.K. Vianich REVIEWED BY: N.R. Simmons	REVISIONS INIT. DATE	DocuSigned by: Natasha R. Simmons 11/8/2024 SIGNATURE DATE SIG. INVENTORY NO. 03-0258T2