

**T.I.P.: R-5726**

**STATE OF NORTH CAROLINA  
DEPARTMENT OF TRANSPORTATION**

**PAVEMENT MARKING PLAN  
MOORE COUNTY**

TIP NO. <b>R-5726</b>	SHEET NO. <b>PMP-1</b>
APPROVED: <b>David W. Bisette</b> <small>—1755047E47864D1—</small>	
DATE: 21-Aug-2024	
SEAL 	
<b>DOCUMENT NOT CONSIDERED FINAL UNLESS ALL SIGNATURES COMPLETED</b>	

**INDEX**

SHEET NO.	DESCRIPTION
PMP-1	TITLE SHEET, INDEX OF SHEETS, LIST OF APPLICABLE ROADWAY STANDARD DRAWINGS, AND GENERAL NOTES
PMP-2	PAVEMENT MARKING SCHEDULE
PMP-3 THRU 25	PAVEMENT MARKING DETAIL

**ROADWAY STANDARD DRAWING**

THE FOLLOWING ROADWAY STANDARDS AS APPEAR IN "ROADWAY STANDARD DRAWINGS" - PROJECT SERVICES UNIT - N.C. DEPARTMENT OF TRANSPORTATION - RALEIGH, N.C., DATED JANUARY 2018 ARE APPLICABLE TO THIS PROJECT AND BY REFERENCE HEREBY ARE CONSIDERED A PART OF THESE PLANS:

STD. NO.	TITLE
1205.01	PAVEMENT MARKINGS - LINE TYPES AND OFFSETS
1205.02	PAVEMENT MARKINGS - TWO-LANE AND MULTILANE ROADWAYS
1205.04	PAVEMENT MARKINGS - INTERSECTIONS
1205.05	PAVEMENT MARKINGS - TURN LANES
1205.08	PAVEMENT MARKINGS - SYMBOLS AND WORD MESSAGES
1205.09	PAVEMENT MARKINGS - PAINTED ISLANDS
1205.10	PAVEMENT MARKINGS - SCHOOL AREAS
1205.11	PAVEMENT MARKINGS - RAILROAD CROSSINGS
1205.13	PAVEMENT MARKINGS - LANE REDUCTIONS
1205.15	PAVEMENT MARKINGS - SUPERSTREETS
1250.01	RAISED PAVEMENT MARKERS - INSTALLATION SPACING
1251.01	RAISED PAVEMENT MARKERS - PERMANENT AND TEMPORARY
1261.01	GUARDRAIL AND BARRIER DELINEATORS - INSTALLATION SPACING
1261.02	GUARDRAIL AND BARRIER DELINEATORS - TYPES AND MOUNTING
1262.01	GUARDRAIL END DELINEATION

**GENERAL NOTES**

THE FOLLOWING GENERAL NOTES APPLY AT ALL TIMES FOR THE DURATION OF THE CONSTRUCTION PROJECT, EXCEPT WHEN OTHERWISE NOTED IN THE PLAN, OR DIRECTED BY THE ENGINEER.

- A) INSTALL PAVEMENT MARKINGS AND PAVEMENT MARKERS ON THE FINAL SURFACE AS FOLLOWS:
 

ROAD NAME	MARKING	MARKER
ALL ROADS	THERMOPLASTIC	SNOWPLOWABLE RAISED
- B) TIE PROPOSED PAVEMENT MARKING LINES TO EXISTING PAVEMENT MARKING LINES.
- C) REMOVE/REPLACE ANY CONFLICTING/DAMAGED PAVEMENT MARKINGS AND MARKERS.
- D) PASSING ZONES WILL BE DETERMINED IN THE FIELD AND MUST BE APPROVED BY THE ENGINEER.
- E) STOP BAR LOCATION AT NON-SIGNALIZED INTERSECTIONS MAY BE ADJUSTED AS DIRECTED BY THE ENGINEER.
- F) UNLESS OTHERWISE SPECIFIED, HEATED-IN-PLACE THERMOPLASTIC MAY BE USED IN LIEU OF EXTRUDED THERMOPLASTIC FOR STOP BARS, SYMBOLS, CHARACTERS AND DIAGONALS. IF HEATED-IN-PLACE IS USED, IT SHALL BE PAID FOR USING THE EXTRUDED THERMOPLASTIC PAY ITEM.

**PLAN REVIEWED BY: N.C.D.O.T. SIGNING AND DELINEATION UNIT**

<u>M. EATON, PE</u>	SIGNING & DELINEATION REGIONAL ENGINEER
<u>M. TRACEY, PE</u>	SIGNING & DELINEATION PROJECT DESIGN ENGINEER

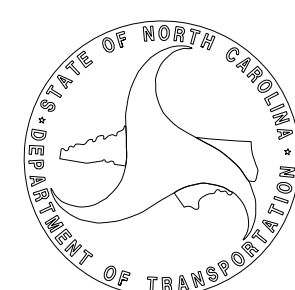



**PLAN PREPARED BY: MOTT MACDONALD**





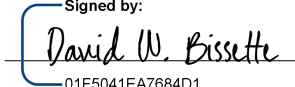





<u>DAVID W BISSETTE, PE</u>	PRINCIPAL PROJECT MANAGER
<u>SAM COLEMAN, PE</u>	PROJECT ENGINEER

*PLANS PREPARED FOR THE NCDOT BY:*

<b>M</b>	MOTT MACDONALD I & E, LLC 1101 HAYNES STREET, SUITE 101 RALEIGH, NC 27604
<b>M</b>	MOTT MACDONALD NC LICENSE NO. F-0669

TIP NO. R-5726	SHEET NO. PMP-2
APPROVED:  DATE: 21-Aug-2024	
	
<b>DOCUMENT NOT CONSIDERED FINAL UNLESS ALL SIGNATURES COMPLETED</b>	
PLANS PREPARED FOR THE NCDOT BY:  MOTT MACDONALD 1 & E, LLC 1101 HAYNES STREET, SUITE 101 RALEIGH, NC 27604 NC LICENSE NO. F-0669	

**PAVEMENT MARKING SCHEDULE**

SYMBOL	DESCRIPTION		
T1	WHITE EDGELINE	(4", 90 MIL)	THERMOPLASTIC
T2	WHITE SOLID LANE LINE	(4", 90 MIL)	THERMOPLASTIC
T3	10 FT. WHITE SKIP	(4", 90 MIL)	THERMOPLASTIC
T4	3 FT. - 9 FT./SP WHITE MINISKIP	(4", 90 MIL)	THERMOPLASTIC
T5	2 FT. - 6 FT./SP WHITE MINISKIP	(4", 90 MIL)	THERMOPLASTIC
T10	YELLOW EDGELINE	(4", 90 MIL)	THERMOPLASTIC
T13	YELLOW DOUBLE CENTER	(4", 90 MIL)	THERMOPLASTIC
T14	2 FT. - 6 FT./SP YELLOW MINISKIP	(4", 90 MIL)	THERMOPLASTIC
T40	WHITE GORELINE	(8", 90 MIL)	THERMOPLASTIC
T41	WHITE DIAGONAL	(8", 90 MIL)	THERMOPLASTIC
T42	YELLOW DIAGONAL	(8", 90 MIL)	THERMOPLASTIC
T60	WHITE LINE, RR X	(16", 90 MIL)	THERMOPLASTIC
T61	WHITE STOPBAR	(24", 90 MIL)	THERMOPLASTIC
	LEFT TURN ARROW	(90 MIL)	THERMOPLASTIC
	RIGHT TURN ARROW	(90 MIL)	THERMOPLASTIC
	STRAIGHT ARROW	(90 MIL)	THERMOPLASTIC
	COMBO. LEFT/STRAIGHT ARROW	(90 MIL)	THERMOPLASTIC
	COMBO. RIGHT/STRAIGHT ARROW	(90 MIL)	THERMOPLASTIC
	U-TURN ARROW	(90 MIL)	THERMOPLASTIC
	COMBO. LEFT/U-TURN ARROW	(90 MIL)	THERMOPLASTIC
	MERGE ARROW	(90 MIL)	THERMOPLASTIC
T100	ALPHANUMERIC CHAR.	(90 MIL)	THERMOPLASTIC
	YELLOW & YELLOW		SNOWPLOWABLE RAISED MARKER
	CRYSTAL & RED		SNOWPLOWABLE RAISED MARKER

7/7/2024  
 G:\374136\_2016-plan-dsn-LSA\proj\RA\_R-5726\Traffic\Signing\Pavement Marking R-5726\_Sgn\_PMP\_02.dgn  
 User: B1582185

PAVEMENT MARKING DETAIL

TIP NO.	SHEET NO.
R-5726	PMP-3
APPROVED: <i>David W. Bisette</i> <small>Professional Engineer No. 31558/EA7864D1</small>	
DATE: 21-Aug-2024	
SEAL	
	
<b>DOCUMENT NOT CONSIDERED FINAL UNLESS ALL SIGNATURES COMPLETED</b>	
PLANS PREPARED FOR THE NCDOT BY:	
<b>M</b>	MOTT MACDONALD 1 & E, LLC 1101 HAYNES STREET, SUITE 101 RALEIGH, NC 27604
<b>M</b>	NC LICENSE NO. F-0669

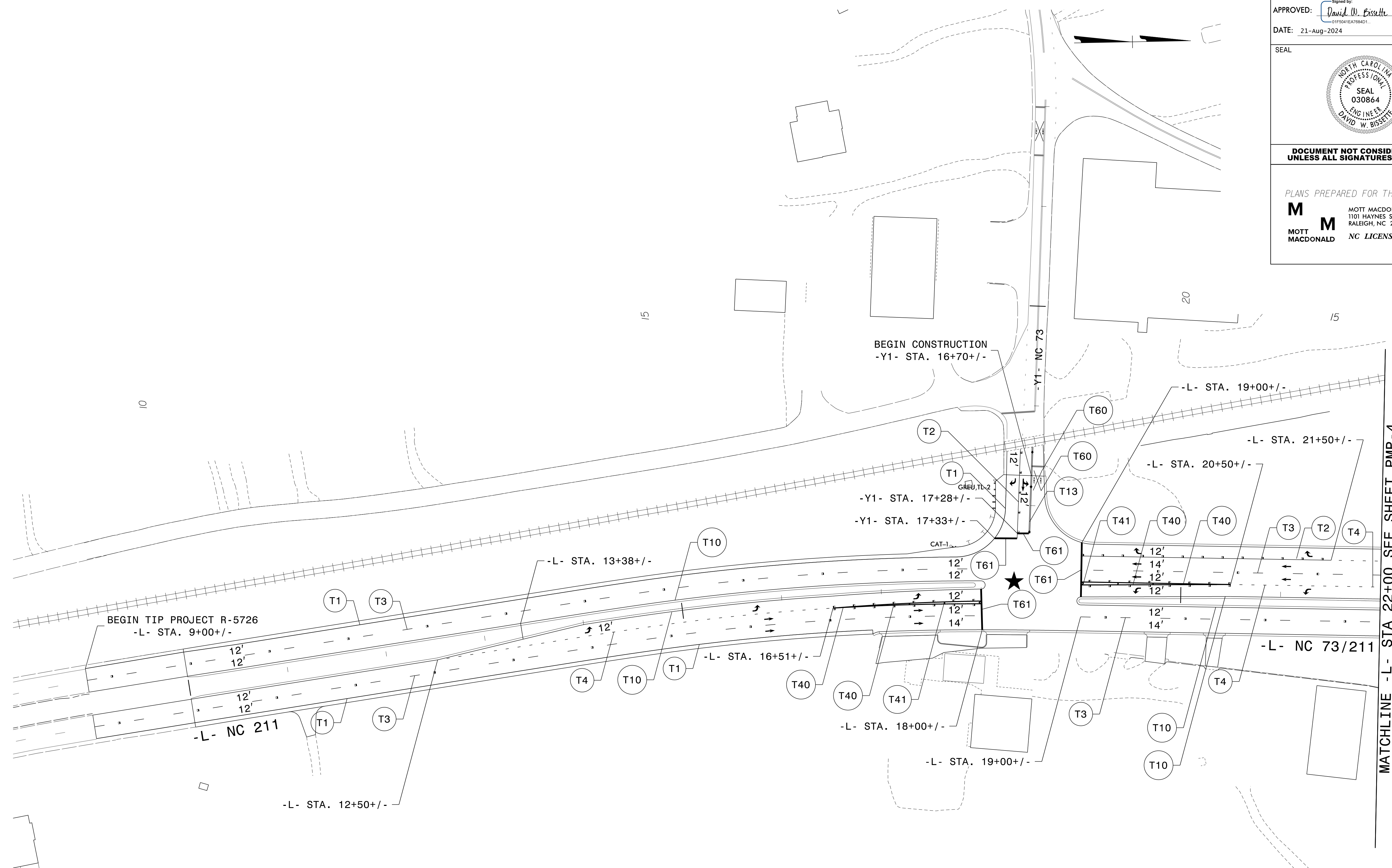

**PAVEMENT MARKING DETAIL**

7/7/2024  
 G:\374195\_2016-plan-dsn\_LSA\proj\RA\_R-5726\Traffic\Signing\Pavement Marking\R-5726\_Sgn\_Pmp\_03.dgn  
 User: B1582185

TIP NO. R-5726	SHEET NO. PMP-4
APPROVED: <i>David W. Bisette</i> <small>Professional Engineer License No. 030864</small>	
DATE: 21-Aug-2024	
SEAL	
	
<b>DOCUMENT NOT CONSIDERED FINAL UNLESS ALL SIGNATURES COMPLETED</b>	
PLANS PREPARED FOR THE NCDOT BY:	
<b>M</b>	MOTT MACDONALD 1 & E, LLC 1101 HAYNES STREET, SUITE 101 RALEIGH, NC 27604
<b>M</b>	NC LICENSE NO. F-0669

MATCHLINE -L- STA 22+00 SEE SHEET PMP-3

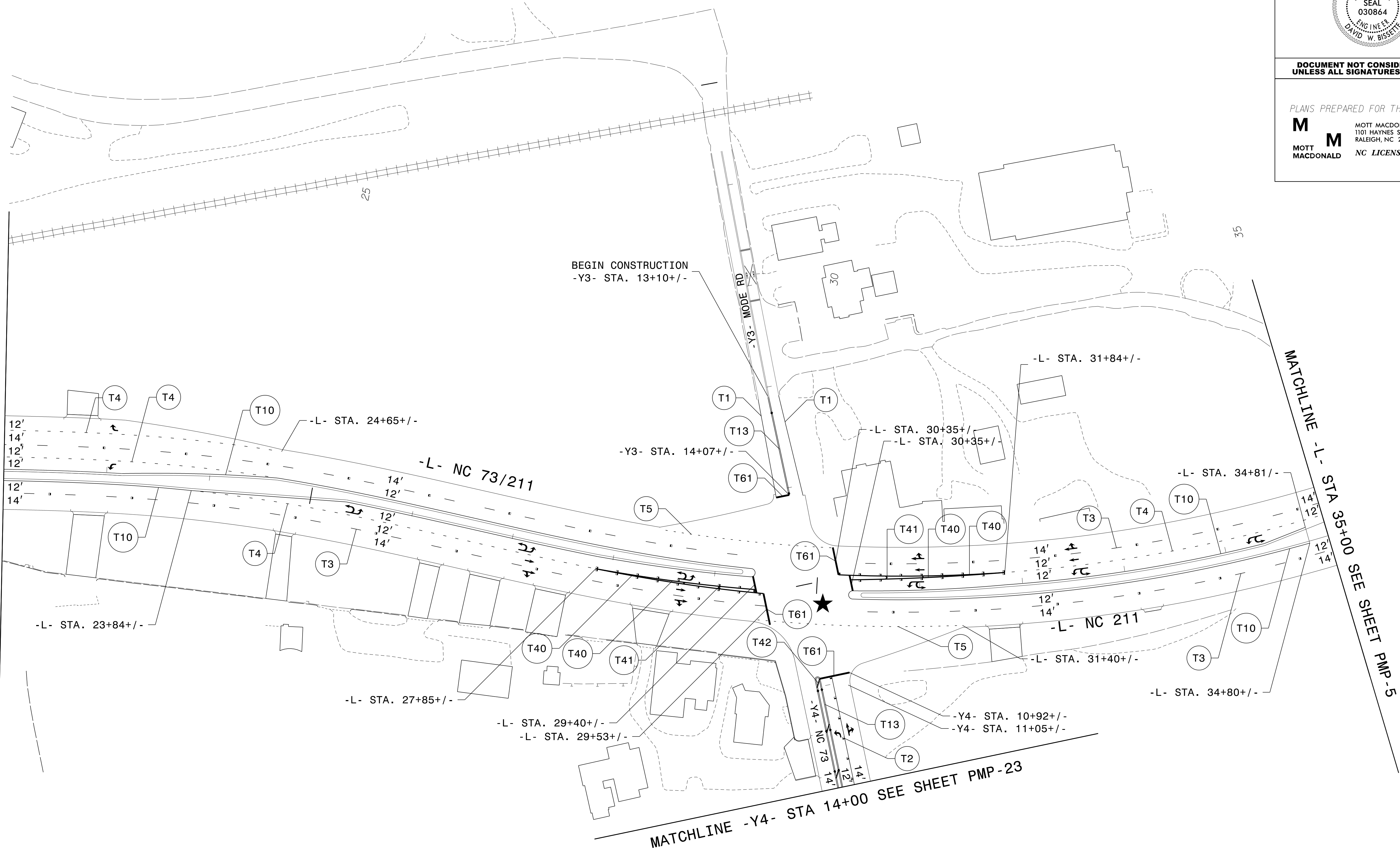

MATCHLINE -Y4- STA 14+00 SEE SHEET PMP-23

PAVEMENT MARKING DETAIL

7/7/2024 10:37:19 AM G:\374195\_2016-plan-dsn\_LSA\proj\RA\_R-5726\Trf\nc\Signing\Pavement Marking R-5726\_Sgn\_PMP\_04.dgn User:DBIS82185

TIP NO.	SHEET NO.
R-5726	PMP-5
APPROVED: <i>David W. Bisette</i>	
DATE: 21-Aug-2024	
SEAL	
DOCUMENT NOT CONSIDERED FINAL UNLESS ALL SIGNATURES COMPLETED	
PLANS PREPARED FOR THE NCDOT BY:	
<b>M</b> MOTT MACDONALD 1 & E, LLC 1101 HAYNES STREET, SUITE 101 RALEIGH, NC 27604 NC LICENSE NO. F-0669	

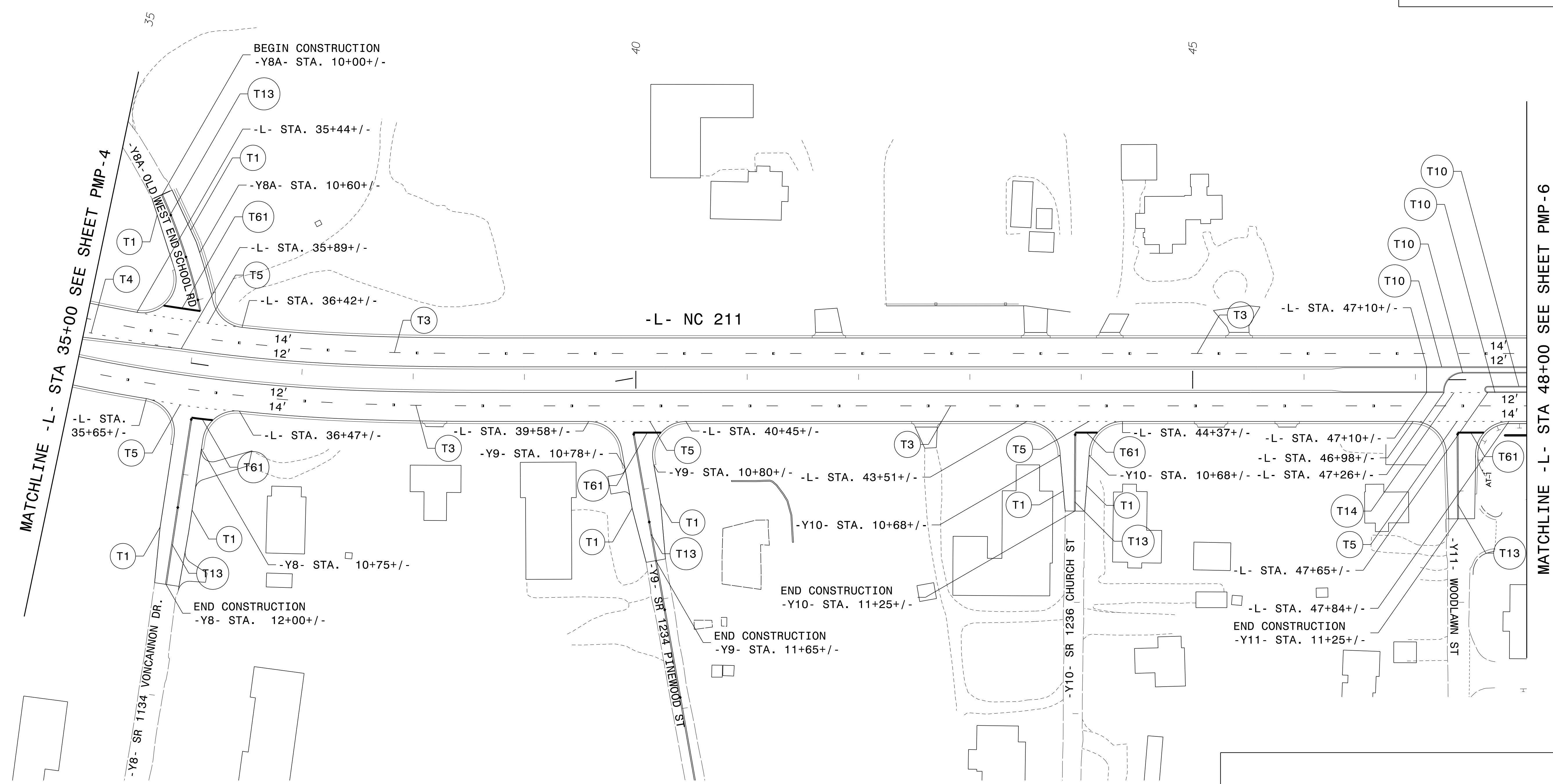

7/7/2024  
 G:\374135\_2016-plan-dsn\_LSA\proj\RA\_R-5726\Traffic\Signing\Pavement Marking\R-5726\_Sgn\_PMP\_05.dgn  
 User: DBIS82185

**PAVEMENT MARKING DETAIL**

TIP NO. R-5726	SHEET NO. PMP-6
APPROVED: <i>David W. Bisette</i> <small>01550016780401</small>	
DATE: 21-Aug-2024	
SEAL	
	
PLANS PREPARED FOR THE NCDOT BY: <b>M</b> MOTT MACDONALD 1 & E, LLC <small>1101 HAYNES STREET, SUITE 101          RALEIGH, NC 27604</small> <b>M</b> NC LICENSE NO. F-0669	

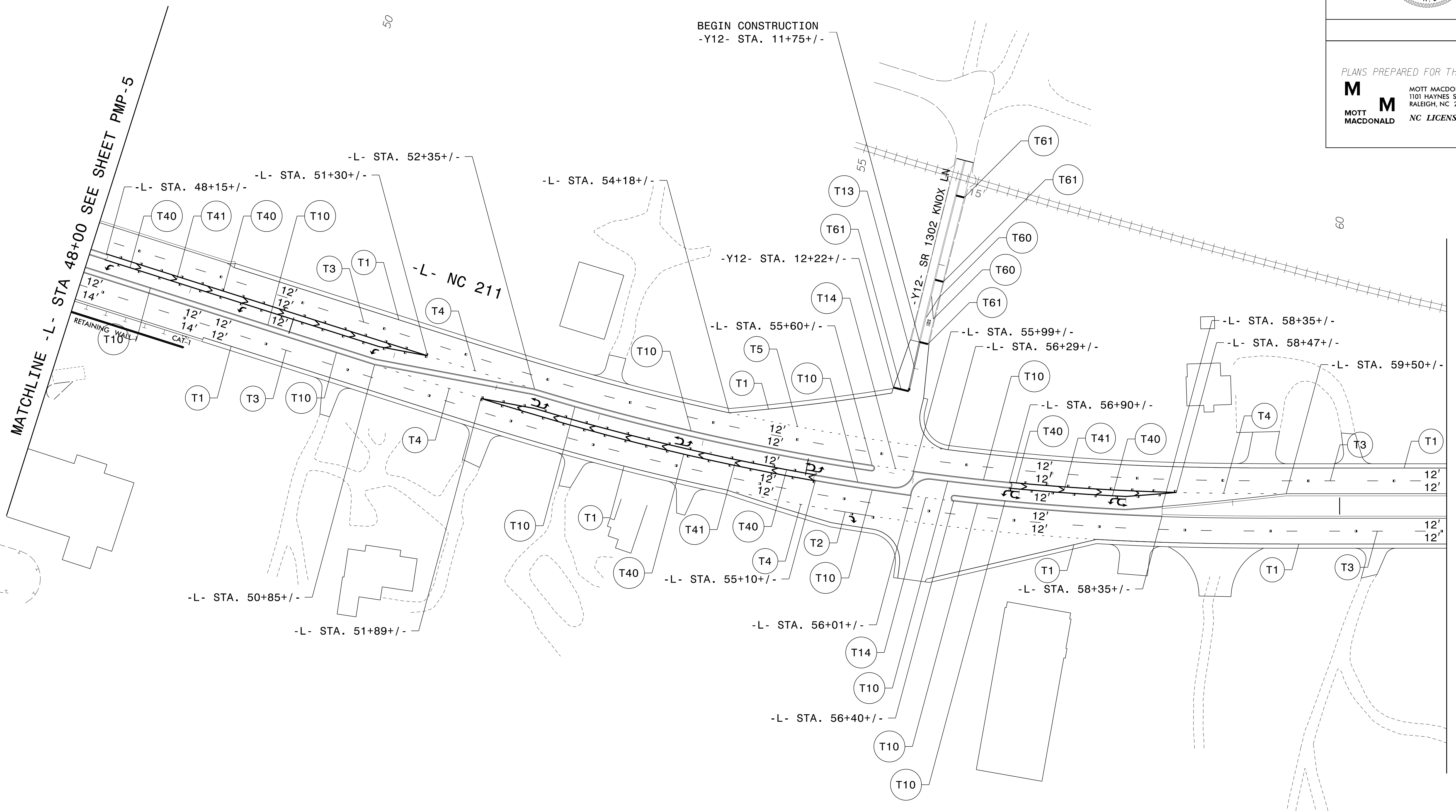

7/25/2024  
 G:\374135\_2016-plan-dsn\_LSA\proj\RA\_R-5726\Traffic\Signing\Pavement Marking R-5726\_Sgn\_PMP\_06.dgn  
 User: B1582185

PAVEMENT MARKING DETAIL

TIP NO. R-5726	SHEET NO. PMP-7
APPROVED: <i>David W. Bisette</i> <small>0175041E/078401...</small>	
DATE: 21-Aug-2024	
SEAL	
	
PLANS PREPARED FOR THE NCDOT BY: <b>M</b> MOTT MACDONALD 1 & E, LLC 1101 HAYNES STREET, SUITE 101 RALEIGH, NC 27604 <b>M</b> MOTT MACDONALD NC LICENSE NO. F-0669	

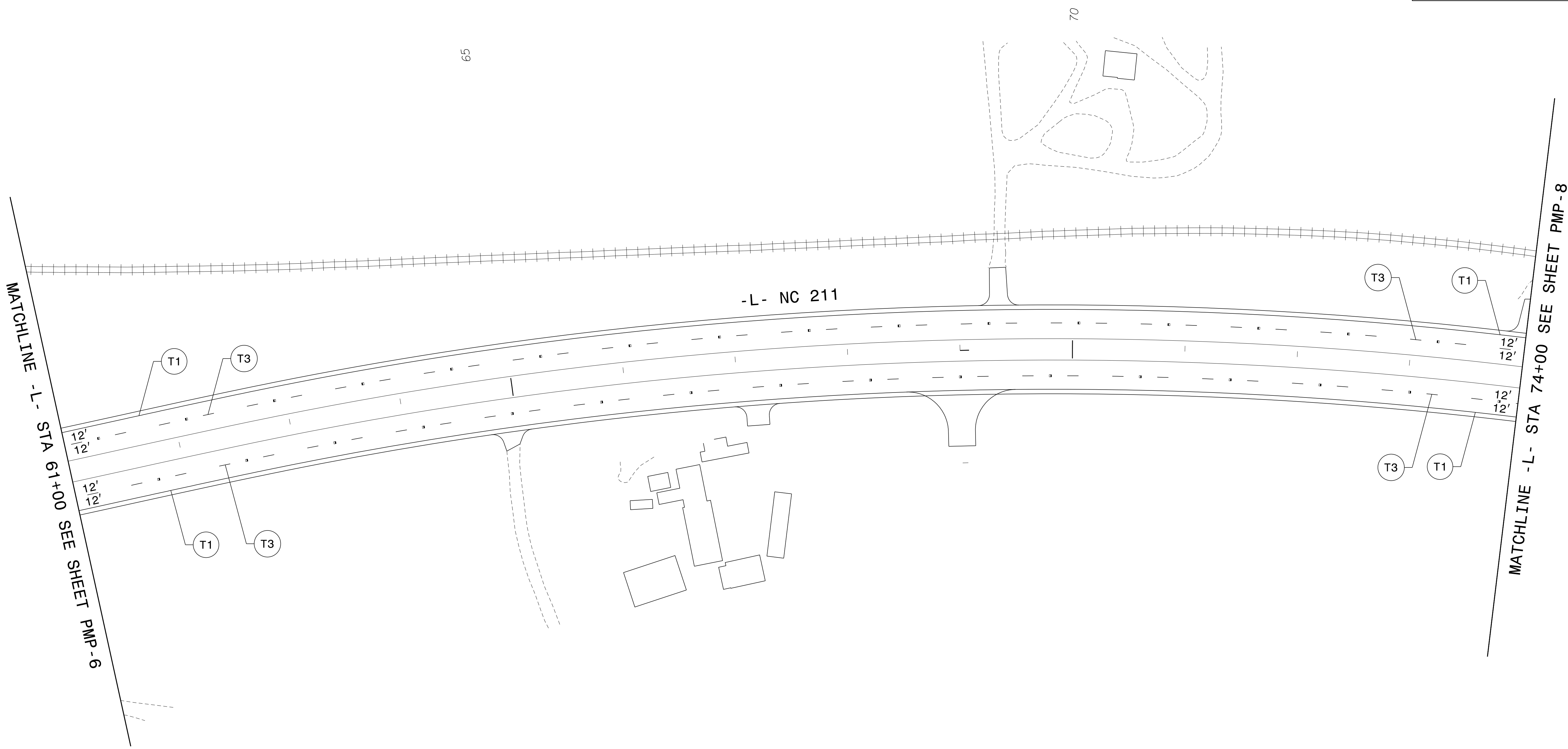
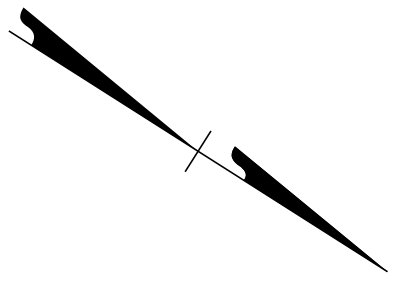

7/7/2024  
 G:\374135\_2016-plan-dsn\_LSA\proj\RA\_R-5726\Traffic\Signing\Pavement Marking R-5726\_Sgn\_PMP\_07.dgn  
 User: B1582185

PAVEMENT MARKING DETAIL

TIP NO. R-5726	SHEET NO. PMP-8
APPROVED: <i>David W. Bisette</i> <small>0155041E/08401...</small>	
DATE: 21-Aug-2024	
SEAL	
	
PLANS PREPARED FOR THE NCDOT BY: <b>M</b> MOTT MACDONALD 1 & E, LLC 1101 HAYNES STREET, SUITE 101 RALEIGH, NC 27604 <b>M</b> MOTT MACDONALD NC LICENSE NO. F-0669	

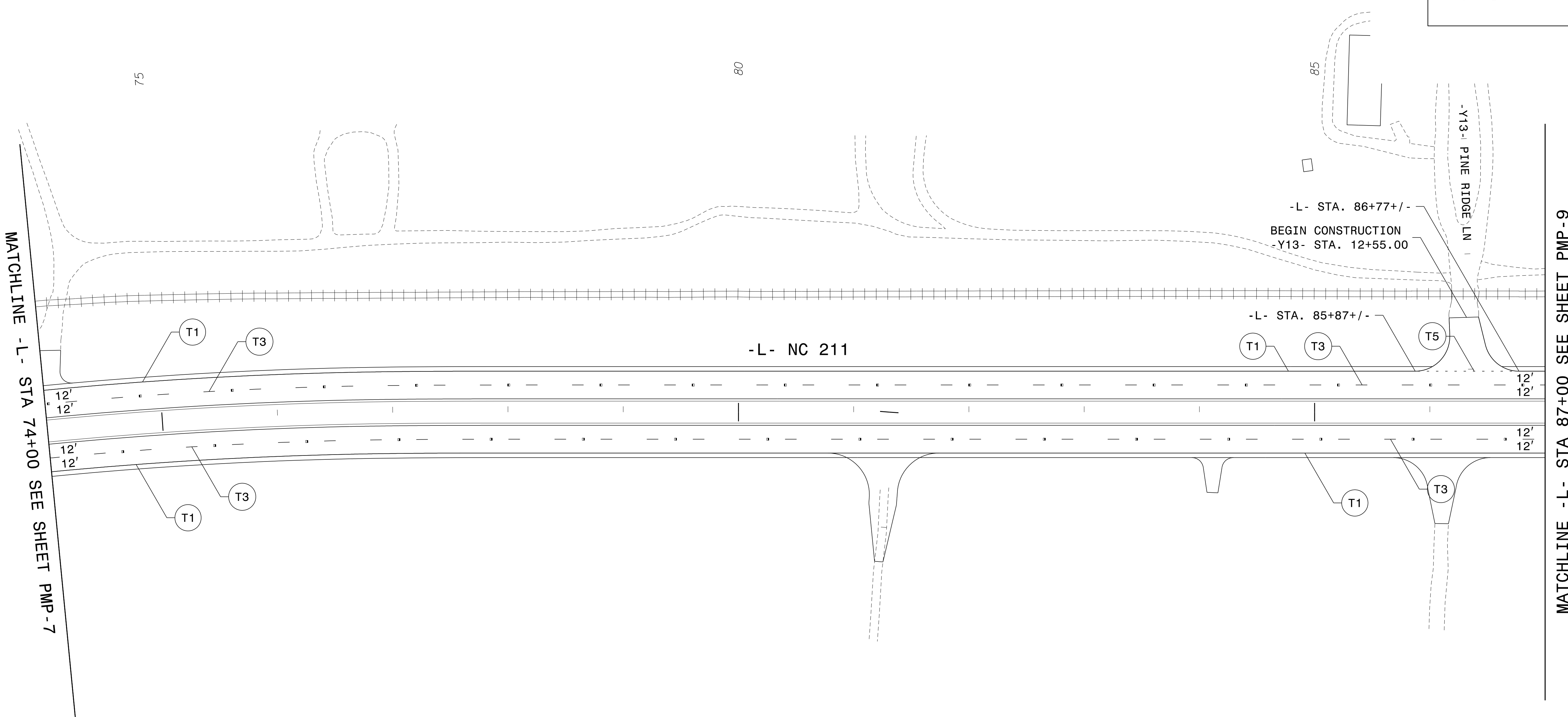

PAVEMENT MARKING DETAIL

7/7/2024  
 G:\374135\_2016-plan-dsn\_LSA\proj\RA\_R-5726\Traffic\Signing\Pavement Marking R-5726\_Sgn\_PMP\_08.dgn  
 User: B1582185



TIP NO. R-5726	SHEET NO. PMP-9
APPROVED: <i>David W. Bisette</i> <small>Professional Engineer No. 31558</small>	
DATE: 21-Aug-2024	
SEAL 	
PLANS PREPARED FOR THE NCDOT BY: <b>M</b> MOTT MACDONALD 1 & E, LLC 1101 HAYNES STREET, SUITE 101 RALEIGH, NC 27604 NC LICENSE NO. F-0669	

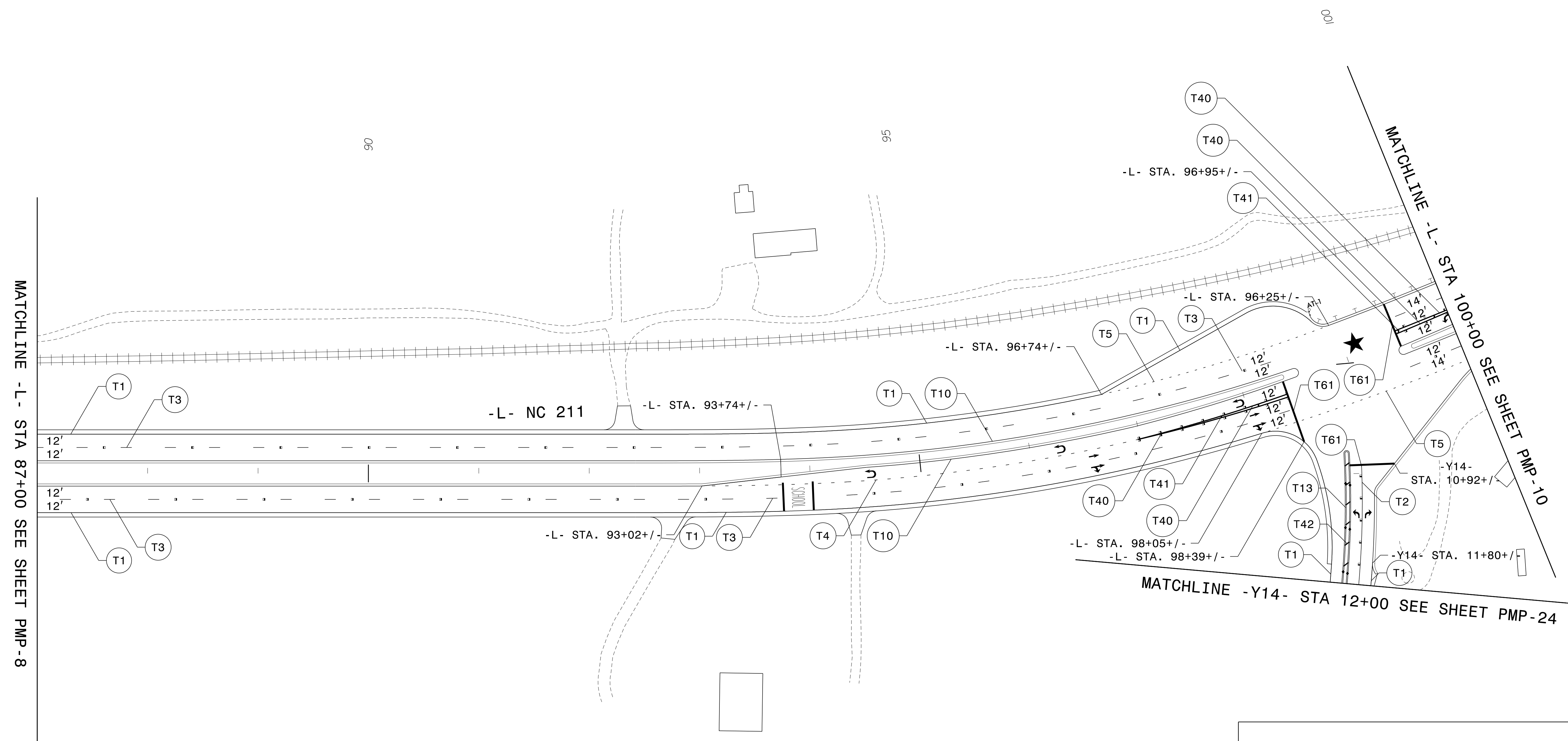
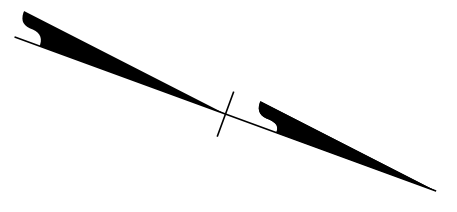

PAVEMENT MARKING DETAIL

7/7/2024 10:37:15 AM G:\374195\_2016-plan-dsn\_LSA\proj\RA\_R-5726\Traffic\Signing\Pavement Marking R-5726\_Sgn\_PMP\_09.dgn User: BJS82185

TIP NO. R-5726	SHEET NO. PMP-10
APPROVED: <i>David W. Bisette</i> <small>0155041E/0706401...</small>	
DATE: 21-Aug-2024	
SEAL	
	
PLANS PREPARED FOR THE NCDOT BY: <b>M</b> MOTT MACDONALD 1 & E, LLC <small>1101 HAYNES STREET, SUITE 101 RALEIGH, NC 27604</small> <b>M</b> MOTT MACDONALD NC LICENSE NO. F-0669	

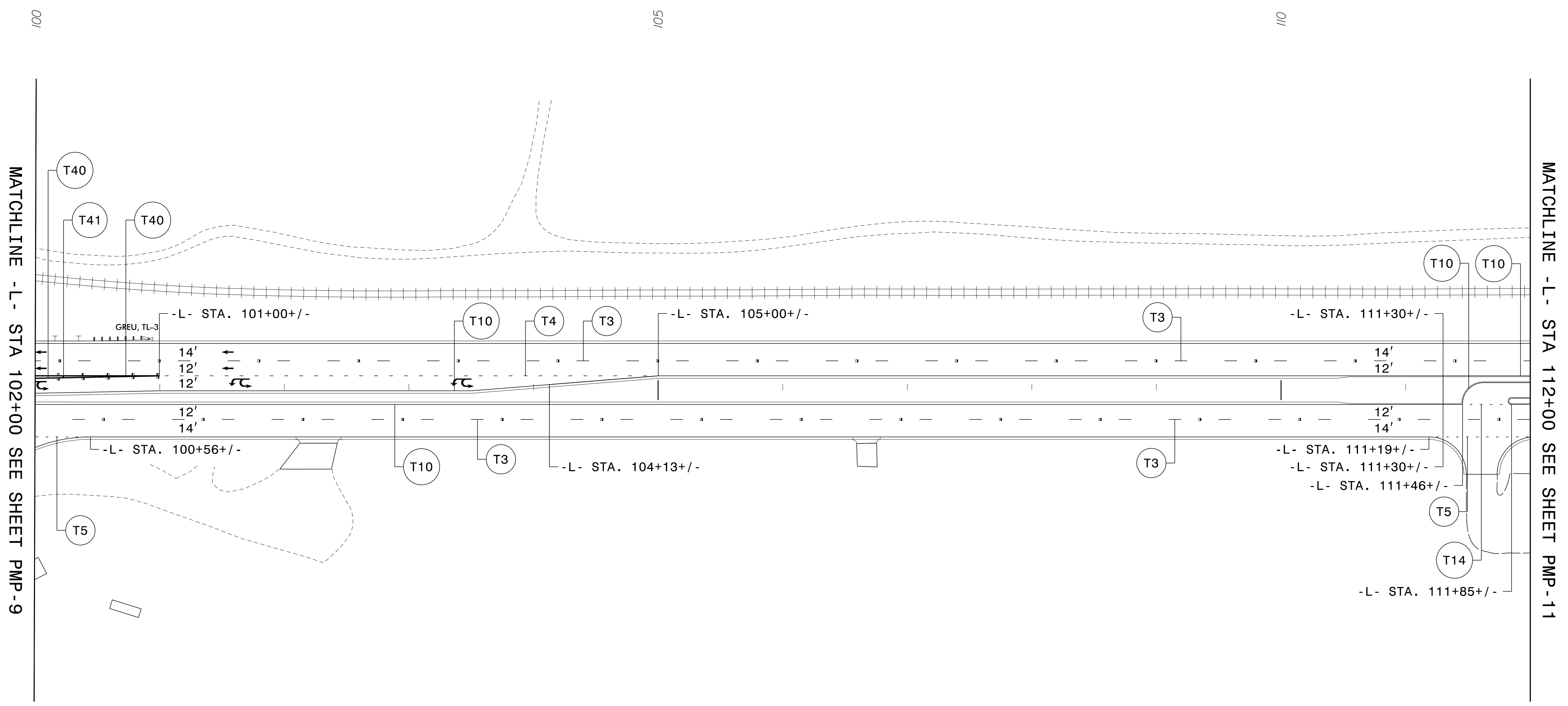
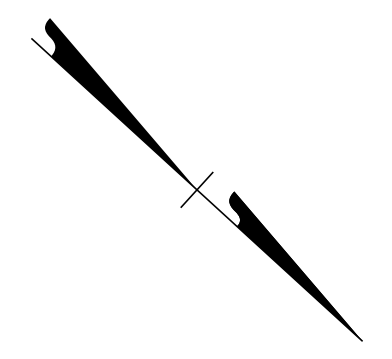

7/25/2024  
 G:\374135\_2016-plan-dsn\_LSA\proj\RA\_R-5726\Traffic\Signing\Pavement Marking\R-5726\_Sgn\_PMP\_10.dgn  
 User: DBIS82185

PAVEMENT MARKING DETAIL

TIP NO. R-5726	SHEET NO. PMP-11
APPROVED: <i>David W. Bisette</i> <small>Professional Engineer No. 030864</small>	
DATE: 21-Aug-2024	
SEAL 	
DOCUMENT NOT CONSIDERED FINAL UNLESS ALL SIGNATURES COMPLETED	
PLANS PREPARED FOR THE NCDOT BY: <b>M</b> MOTT MACDONALD 1 & E, LLC 1101 HAYNES STREET, SUITE 101 RALEIGH, NC 27604 NC LICENSE NO. F-0669	

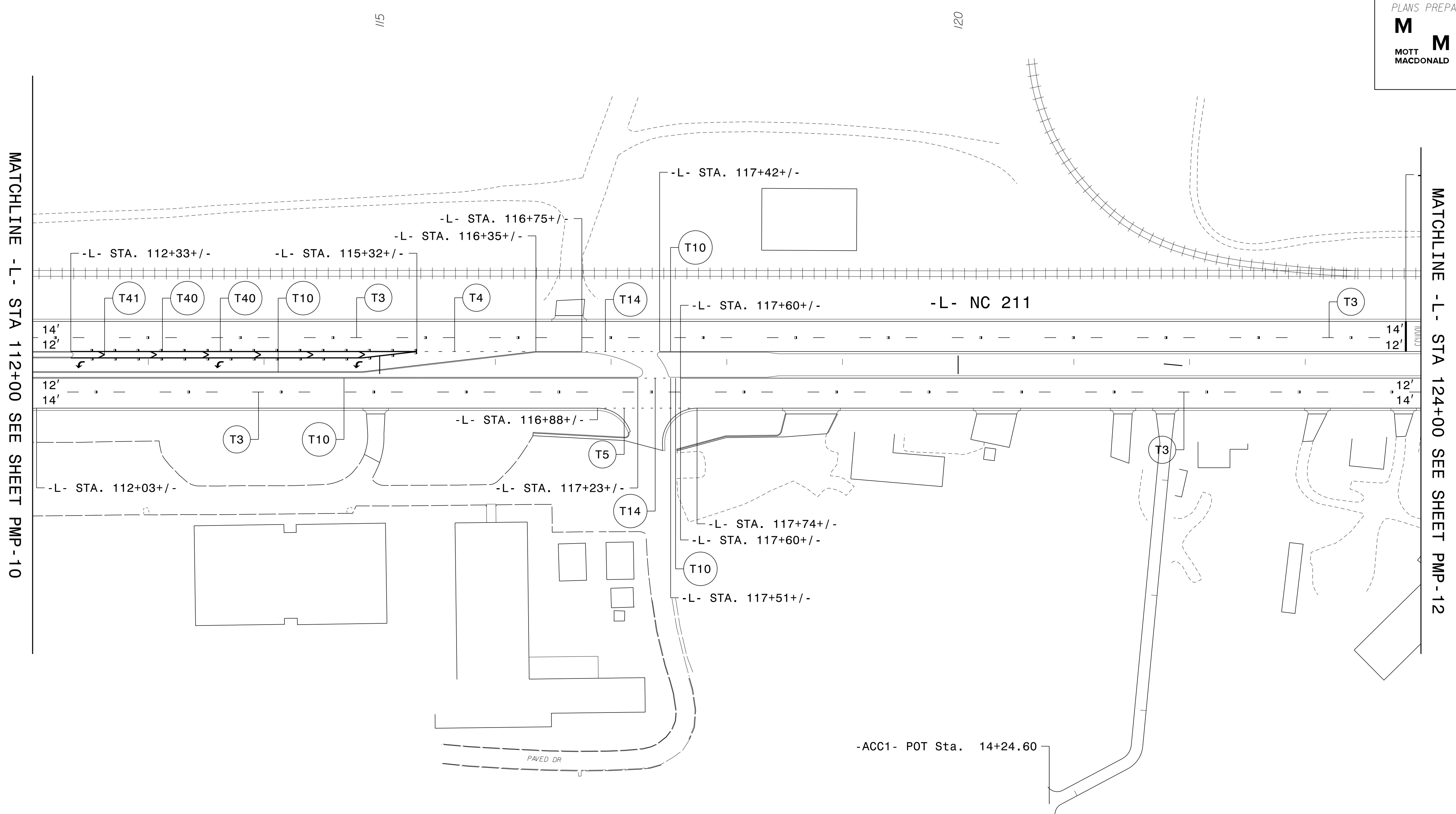

PAVEMENT MARKING DETAIL

7/7/2024  
G:\374195\_2016-plan-dsn\_LSA\proj\RA\_R-5726\Traffic\Signing\Pavement Marking\R-5726\_Sgn\_PMP-11.dgn  
User: DBIS82185

TIP NO. R-5726	SHEET NO. PMP-12
APPROVED: <i>David W. Bisette</i> <small>0155041E/87864D1...</small>	
DATE: 21-Aug-2024	
SEAL	
	
PLANS PREPARED FOR THE NCDOT BY: <b>M</b> MOTT MACDONALD 1 & E, LLC <small>1101 HAYNES STREET, SUITE 101          RALEIGH, NC 27604</small> <b>M</b> MOTT MACDONALD NC LICENSE NO. F-0669	

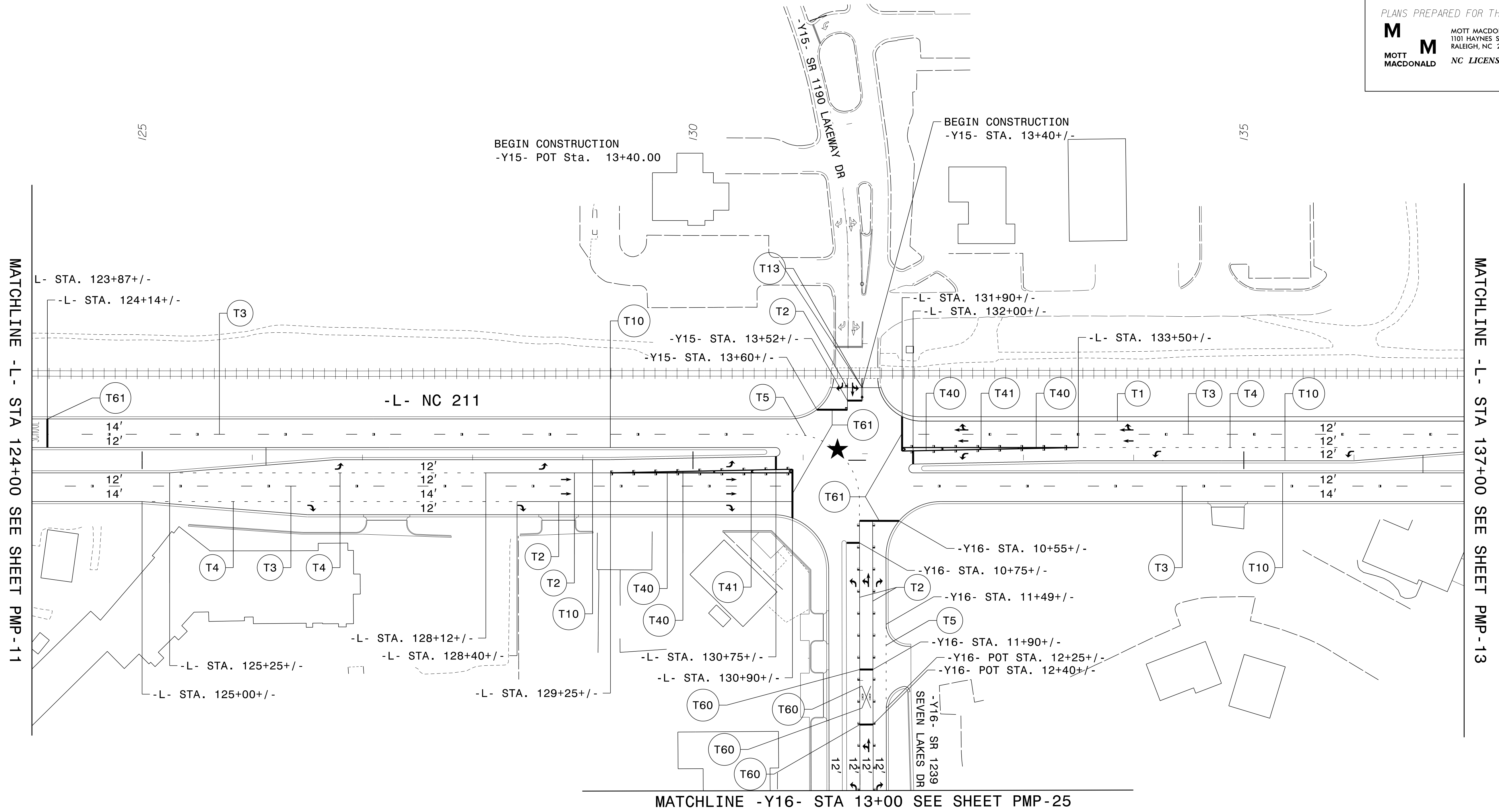
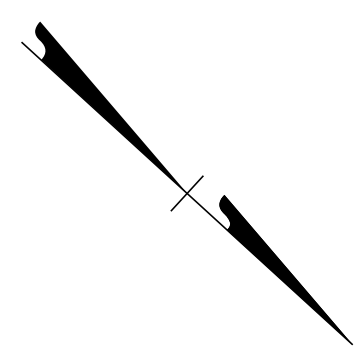

7/25/2024 6:37:41 PM G:\374135\_2016-plan-dsn\_LSA\proj\RA\_R-5726\Traffic\Signing\Pavement Marking R-5726\_Sgn\_PMP-12.dgn User:RBS82185

PAVEMENT MARKING DETAIL

TIP NO. R-5726	SHEET NO. PMP-13
APPROVED: <i>David W. Bisette</i> <small>Professional Engineer No. 030864</small>	
DATE: 21-Aug-2024	
SEAL	
	
PLANS PREPARED FOR THE NCDOT BY: <b>M</b> MOTT MACDONALD 1 & E, LLC 1101 HAYNES STREET, SUITE 101 RALEIGH, NC 27604 <b>M</b> MOTT MACDONALD NC LICENSE NO. F-0669	

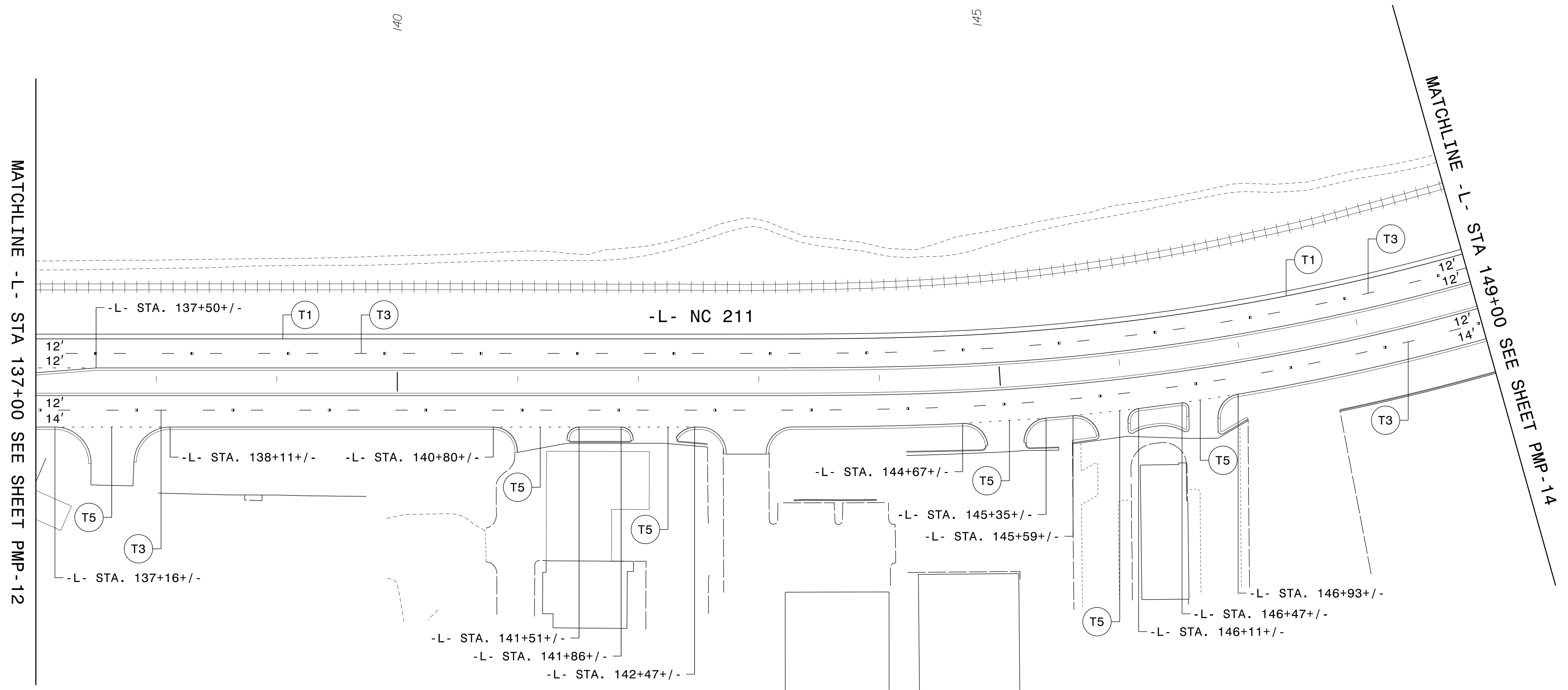
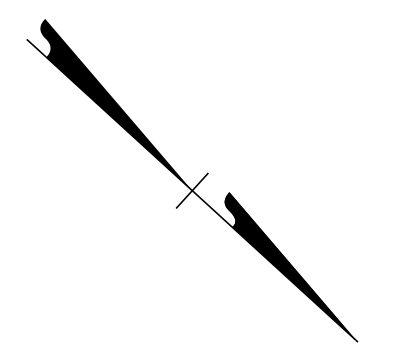

**PAVEMENT MARKING DETAIL**

7/7/2024  
 G:\374195\_2016-plan-dsn\_LSA\proj\RA\_R-5726\Traffic\Signing\Pavement Marking R-5726\_Sgn\_PMP-13.dgn  
 User: DBIS82185

TIP NO. R-5726	SHEET NO. PMP-14
APPROVED: <i>David W. Bisette</i> <small>0175041E/87864D1...</small>	
DATE: 21-Aug-2024	
SEAL	
	
PLANS PREPARED FOR THE NCDOT BY: <b>M</b> MOTT MACDONALD 1 & E, LLC 1101 HAYNES STREET, SUITE 101 RALEIGH, NC 27604 <b>M</b> MOTT MACDONALD NC LICENSE NO. F-0669	

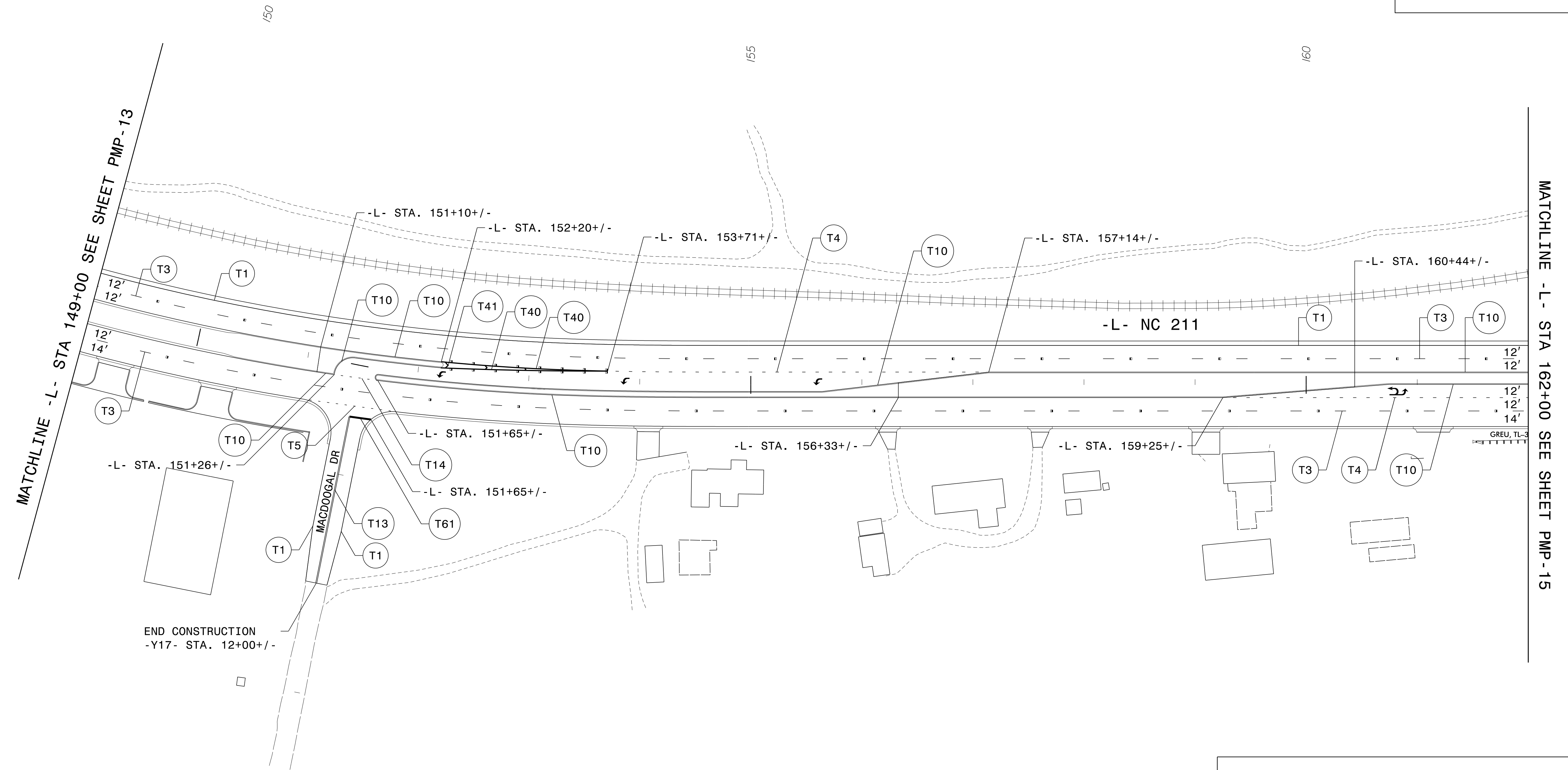

**PAVEMENT MARKING DETAIL**

7/7/2024  
 G:\374195\_2016-plan-dsn\_LSA\proj\RA\_R-5726\Traffic\Signing\Pavement Marking\R-5726\_Sgn\_PMP\_14.dgn  
 User: DBIS82185

TIP NO.	SHEET NO.
R-5726	PMP-15
APPROVED: <i>David W. Bisette</i>	
DATE: 21-Aug-2024	
SEAL	
	
<b>DOCUMENT NOT CONSIDERED FINAL UNLESS ALL SIGNATURES COMPLETED</b>	
PLANS PREPARED FOR THE NCDOT BY:	
<b>M</b> MOTT MACDONALD 1 & E, LLC 1101 HAYNES STREET, SUITE 101 RALEIGH, NC 27604 <b>M</b> MOTT MACDONALD NC LICENSE NO. F-0669	

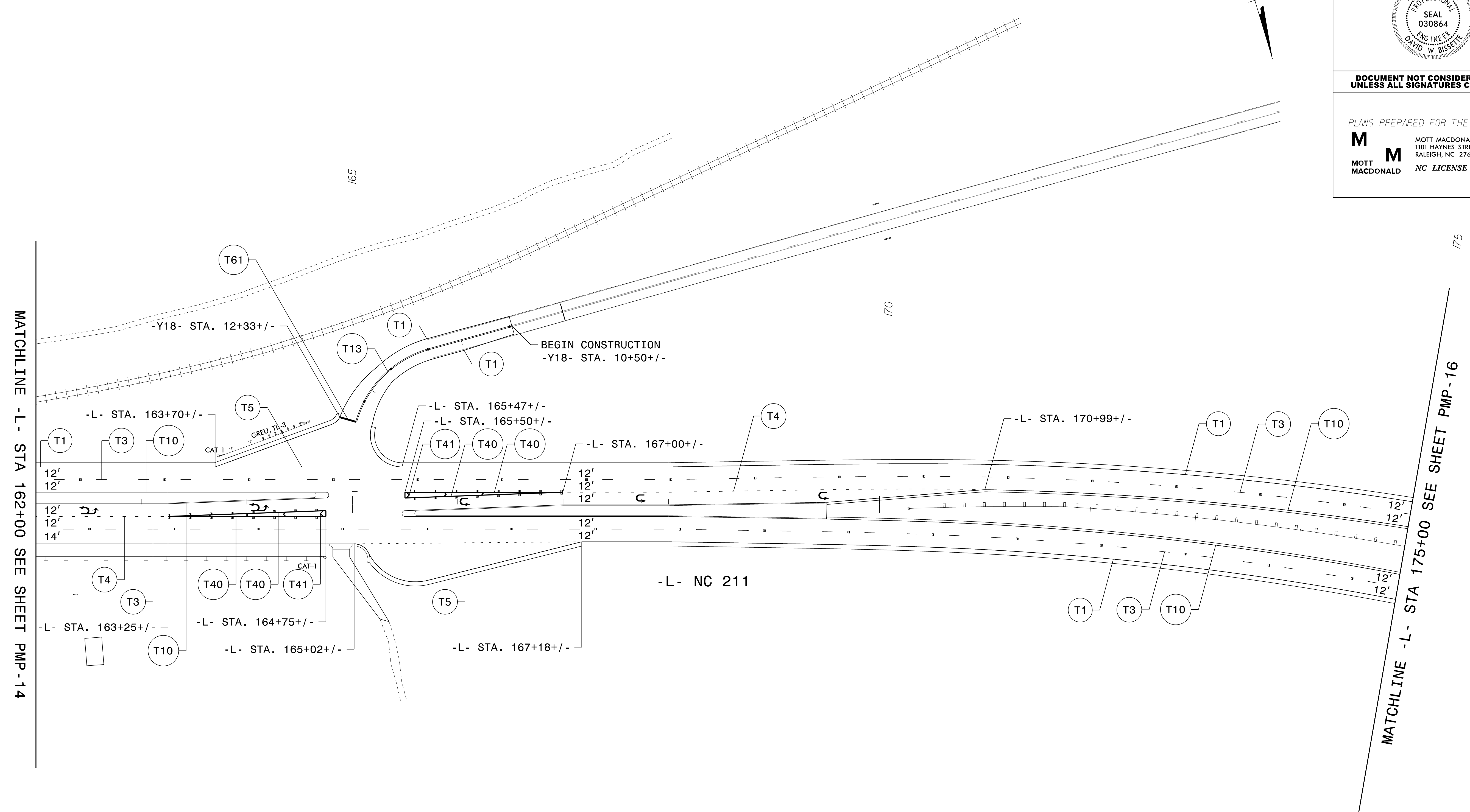

MATCHLINE -L- STA 162+00 SEE SHEET PMP-14

MATCHLINE -L- STA 175+00 SEE SHEET PMP-16

PAVEMENT MARKING DETAIL

7/7/2024  
G:\374135\_2016-plan-dsn\_LSA\proj\RA\_R-5726\Traffic\Signing\Pavement Marking R-5726\_Sgn\_PMP-15.dgn  
User: DBIS82185

TIP NO. R-5726	SHEET NO. PMP-16
APPROVED: <i>David W. Bisette</i> <small>01/25/2016/EA/786401...</small>	
DATE: 21-Aug-2024	
SEAL	
	
PLANS PREPARED FOR THE NCDOT BY: <b>M</b> MOTT MACDONALD 1 & E, LLC 1101 HAYNES STREET, SUITE 101 RALEIGH, NC 27604 <b>M</b> MOTT MACDONALD NC LICENSE NO. F-0669	

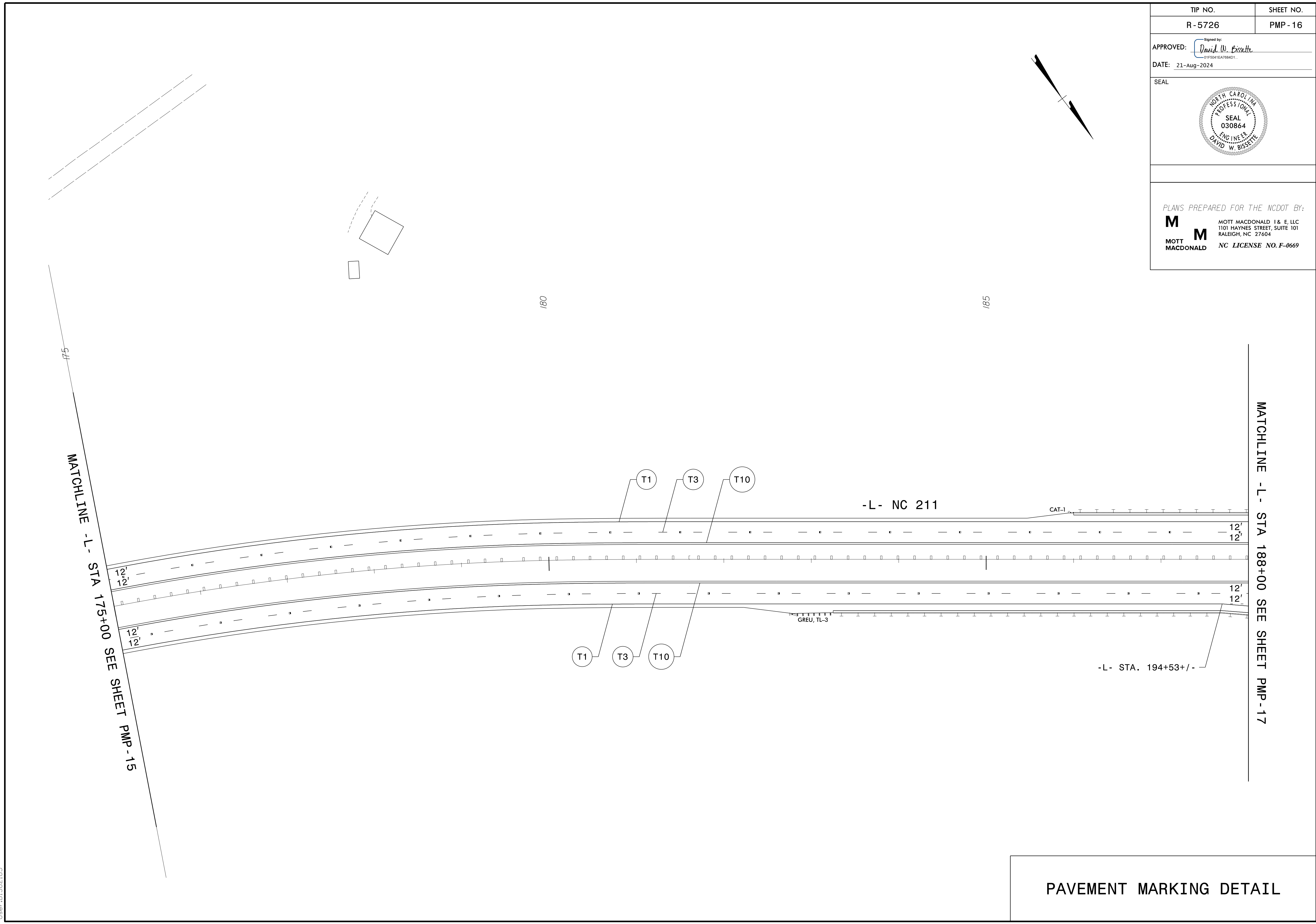

7/7/2024  
 G:\374135\_2016-plan-dsn\_LSA\proj\RA\_R-5726\Traffic\Signing\Pavement Marking R-5726\_Sgn\_PMP-16.dgn  
 User: BJS82185

PAVEMENT MARKING DETAIL



TIP NO. R-5726	SHEET NO. PMP-17
APPROVED: <i>David W. Bisette</i> <small>0155041E47864D1...</small>	
DATE: 21-Aug-2024	
SEAL	
	
PLANS PREPARED FOR THE NCDOT BY: <b>M</b> MOTT MACDONALD 1 & E, LLC 1101 HAYNES STREET, SUITE 101 RALEIGH, NC 27604 <b>M</b> MOTT MACDONALD NC LICENSE NO. F-0669	

MATCHLINE -L- STA 188+00 SEE SHEET PMP-16

MATCHLINE -L- STA 202+00 SEE SHEET PMP-18

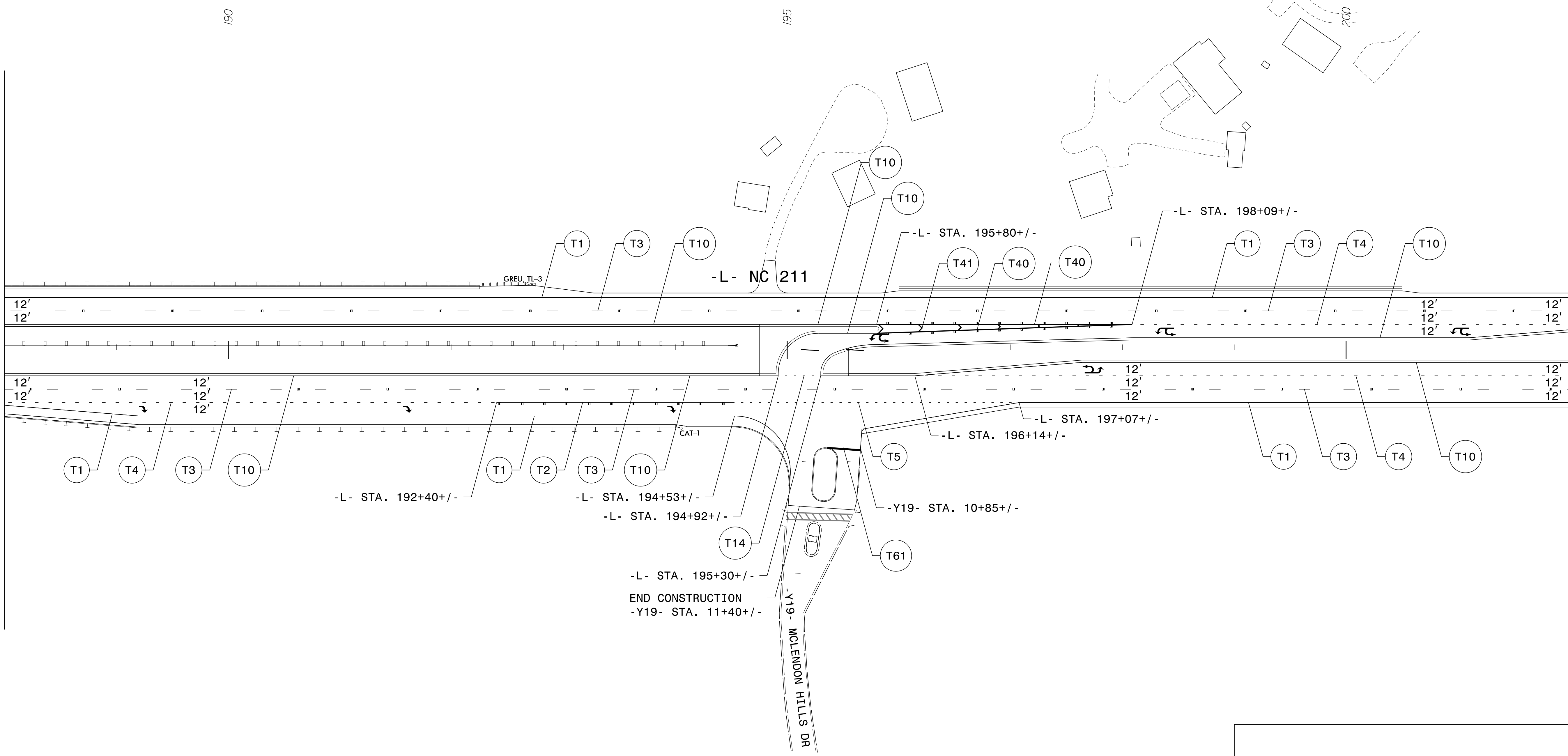

PAVEMENT MARKING DETAIL

7/7/2024 6:37:19 PM G:\374195\_2016-plan-dsn\_LSA\p-01\RA\_R-5726\Traffic\Signing\Pavement Marking\R-5726\_Sgn\_PMP-17.dgn User:FBIS82185

TIP NO. R-5726	SHEET NO. PMP-18
APPROVED: <i>David W. Bisette</i> <small>Professional Engineer No. 030864</small>	
DATE: 21-Aug-2024	
SEAL 	
DOCUMENT NOT CONSIDERED FINAL UNLESS ALL SIGNATURES COMPLETED	
PLANS PREPARED FOR THE NCDOT BY: <b>M</b> MOTT MACDONALD 1 & E, LLC 1101 HAYNES STREET, SUITE 101 RALEIGH, NC 27604 NC LICENSE NO. F-0669	

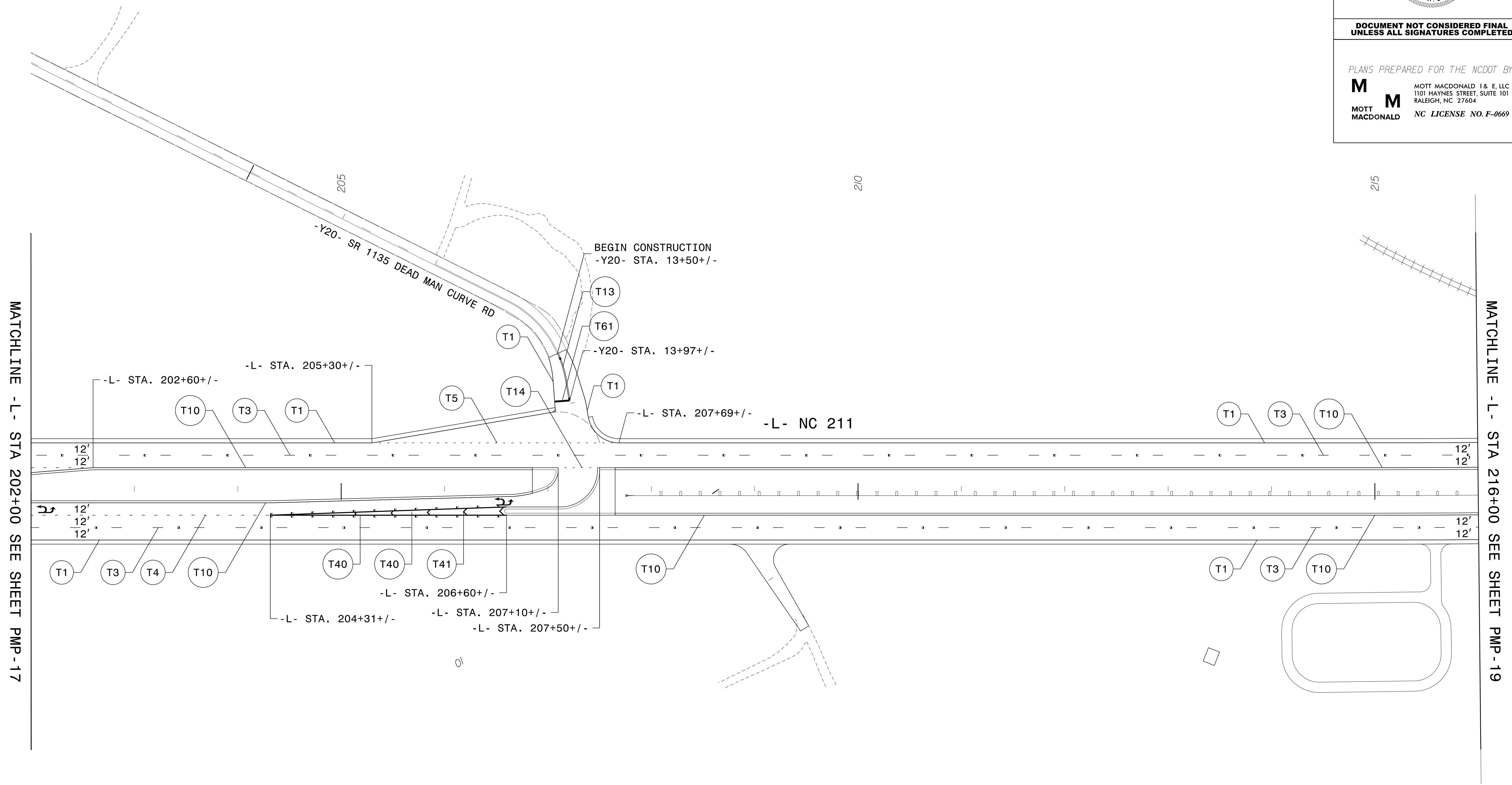
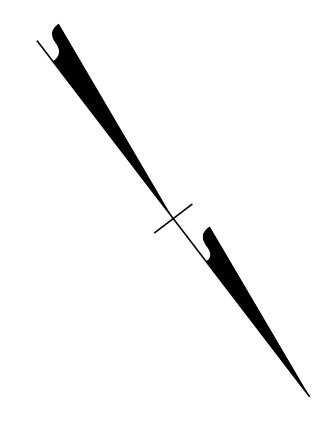

7/7/2024 10:37:19 AM G:\374135\_2016-plan-dsn.LSA\proj\RA\_R-5726\Traffic\Signing\Pavement Marking R-5726\_Sgn\_PMP-18.dgn User: BJS82185

PAVEMENT MARKING DETAIL

TIP NO. R-5726	SHEET NO. PMP-19
APPROVED: <i>David W. Bisette</i> <small>Professional Engineer License No. 030864</small>	
DATE: 21-Aug-2024	
SEAL	
	
<b>DOCUMENT NOT CONSIDERED FINAL UNLESS ALL SIGNATURES COMPLETED</b>	
PLANS PREPARED FOR THE NCDOT BY:	
<b>M</b> MOTT MACDONALD	MOTT MACDONALD 1 & E, LLC 1101 HAYNES STREET, SUITE 101 RALEIGH, NC 27604 NC LICENSE NO. F-0669

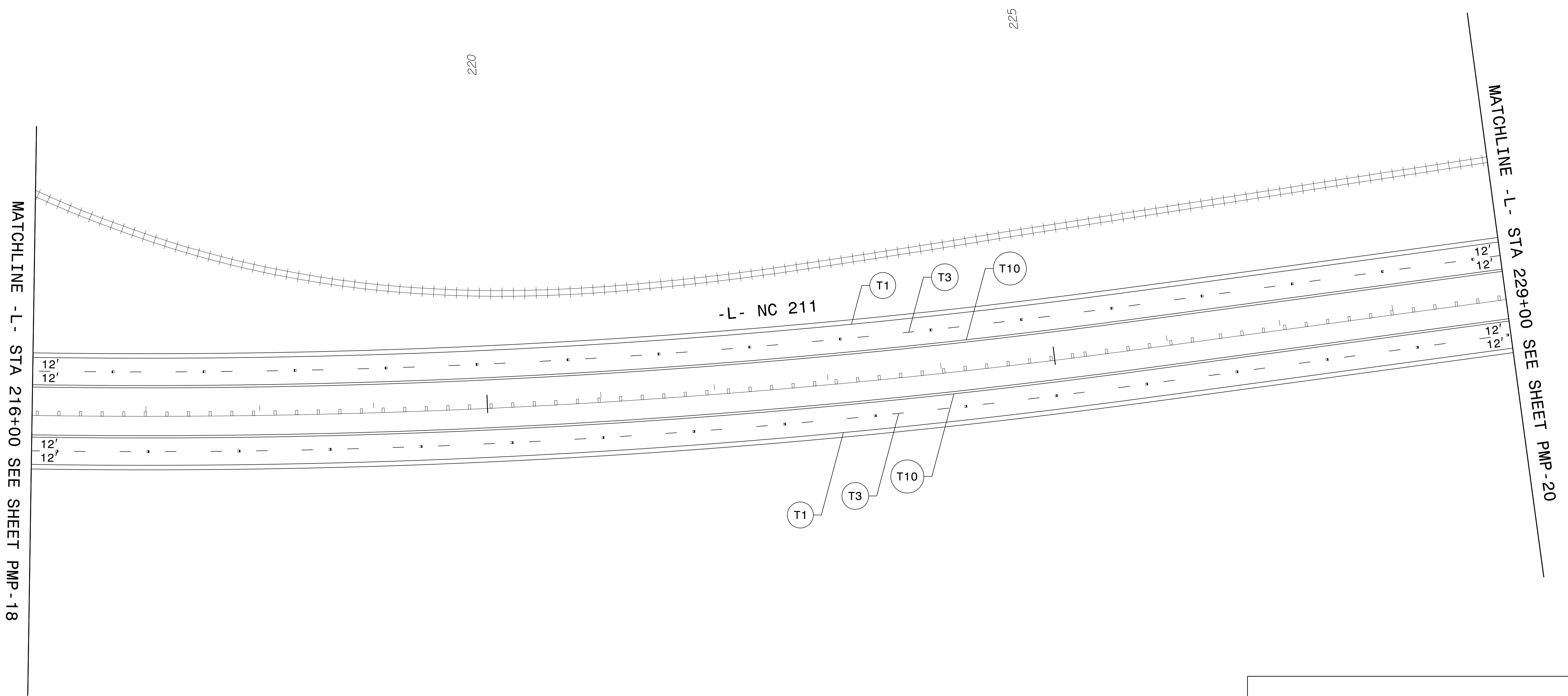
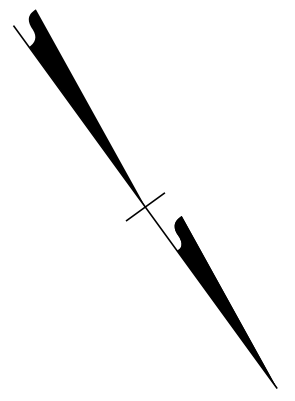

7/7/2024 10:37:19 AM G:\374195\_2016-plan-dsn-LSA\proj\RA\_R-5726\Traffic\Signing\Pavement Marking R-5726\_Sgn\_PMP\_19.dgn User: DBIS82185

PAVEMENT MARKING DETAIL

TIP NO. R-5726	SHEET NO. PMP-20
APPROVED: <i>David W. Bisette</i> <small>Professional Engineer No. 31559/EA7864D1</small>	
DATE: 21-Aug-2024	
SEAL	
	
PLANS PREPARED FOR THE NCDOT BY: <b>M</b> MOTT MACDONALD 1 & E, LLC 1101 HAYNES STREET, SUITE 101 RALEIGH, NC 27604 <b>M</b> MOTT MACDONALD NC LICENSE NO. F-0669	

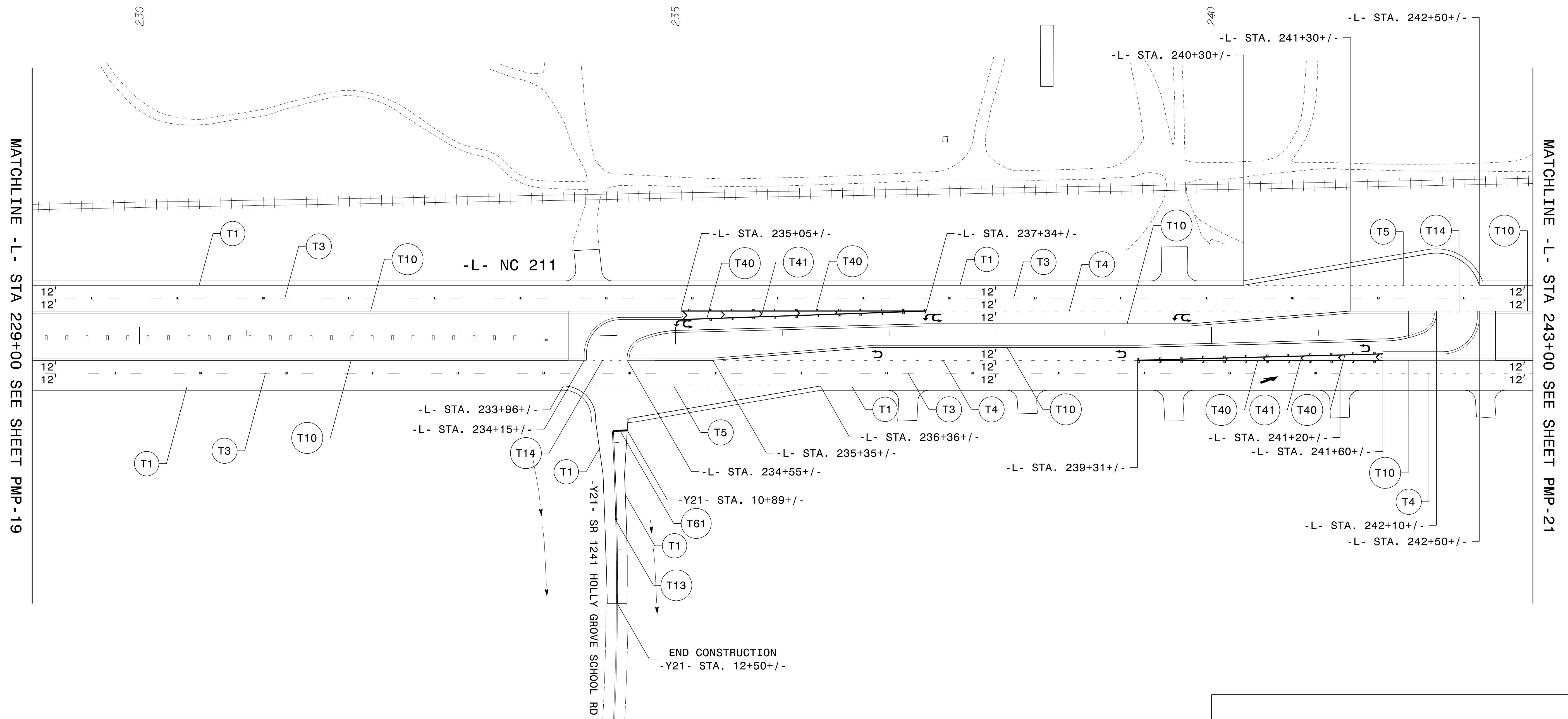

PAVEMENT MARKING DETAIL

7/7/2024 10:37:41 AM G:\374195\_2016-plan-dsn\_LSA\proj\RA\_R-5726\Traffic\Signing\Pavement Marking R-5726\_Sgn\_PMP-20.dgn User: DBIS82185

TIP NO. R-5726	SHEET NO. PMP-21
APPROVED: <i>David W. Bisette</i> <small>0155041E/07864D1...</small>	
DATE: 21-Aug-2024	
SEAL	
	
PLANS PREPARED FOR THE NCDOT BY: <b>M</b> MOTT MACDONALD 1 & E, LLC 1101 HAYNES STREET, SUITE 101 RALEIGH, NC 27604 <b>M</b> MOTT MACDONALD NC LICENSE NO. F-0669	

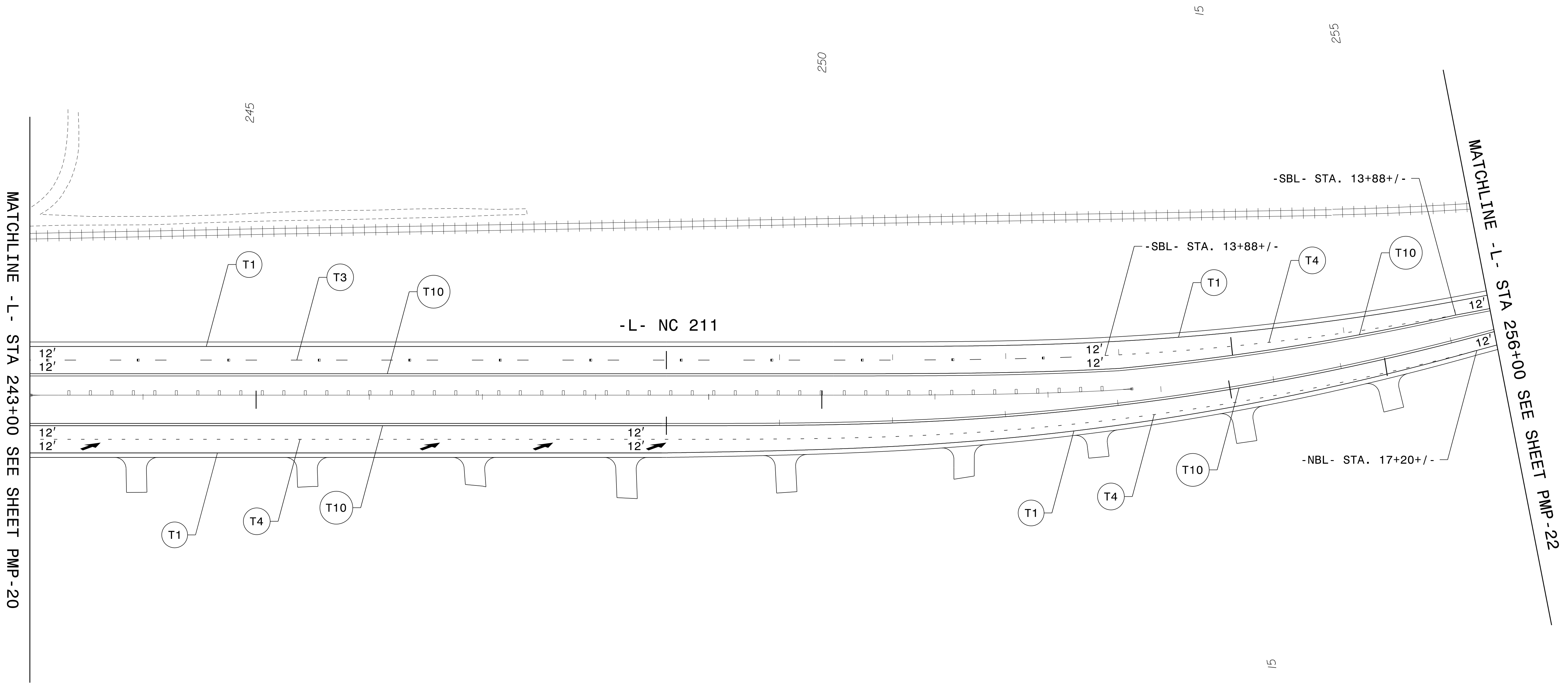
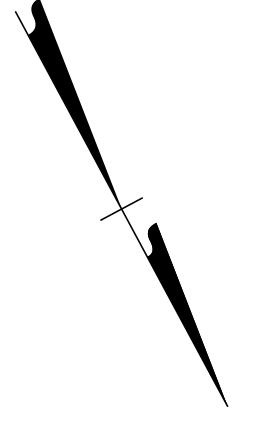

7/7/2024  
 G:\374195\_2016-plan-dsn\_LSA\proj\RA\_R-5726\Traffic\Signing\Pavement Marking R-5726\_Sgn\_PMP-21.dgn  
 User: DBIS82185

PAVEMENT MARKING DETAIL

TIP NO. R-5726	SHEET NO. PMP-22
APPROVED: <i>David W. Bisette</i> <small>0155041E47864D1...</small>	
DATE: 21-Aug-2024	
SEAL	
	
<b>DOCUMENT NOT CONSIDERED FINAL UNLESS ALL SIGNATURES COMPLETED</b>	
PLANS PREPARED FOR THE NCDOT BY:	
<b>M</b> MOTT MACDONALD 1 & E, LLC 1101 HAYNES STREET, SUITE 101 RALEIGH, NC 27604 <b>M</b> MOTT MACDONALD NC LICENSE NO. F-0669	

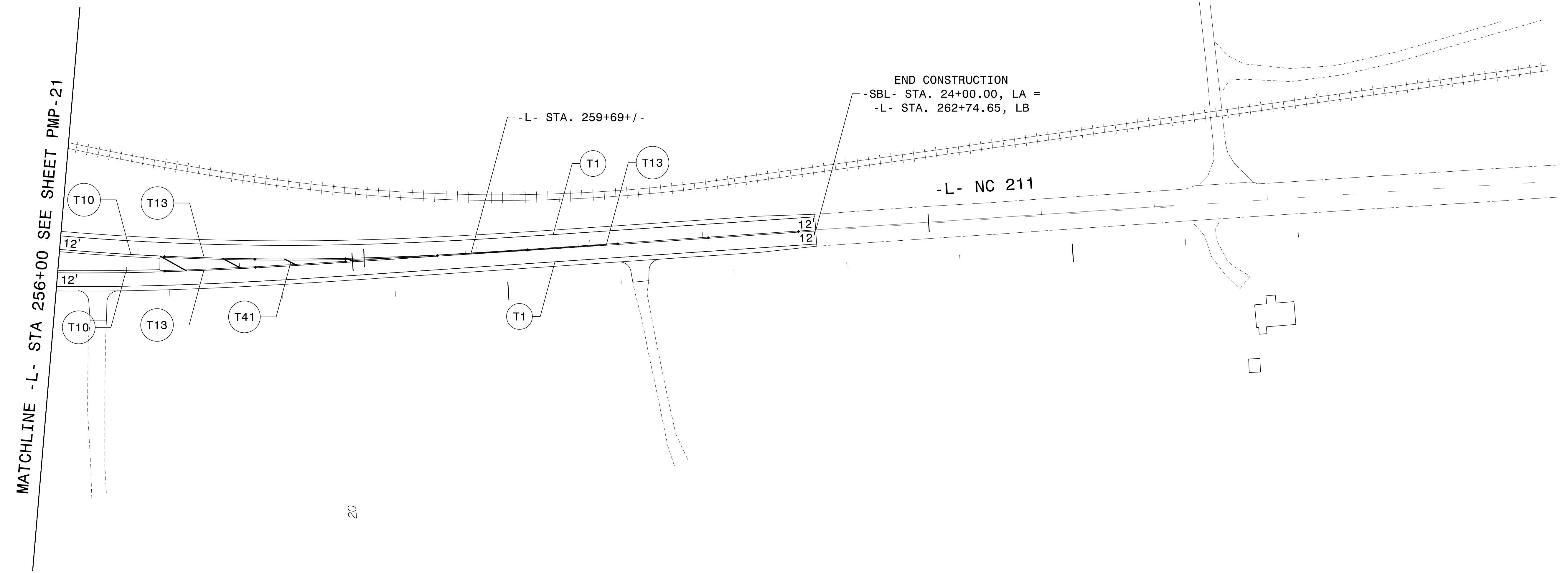
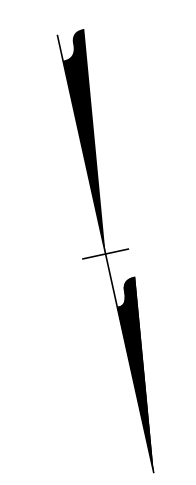

PAVEMENT MARKING DETAIL

7/7/2024 10:37:19 AM G:\374135\_2016-plan-dsn\_LSA\proj\RA\_R-5726\Traffic\Signing\Pavement Marking R-5726\_Sgn\_PMP-22.dgn User: DBIS82185

TIP NO. R-5726	SHEET NO. PMP-23
APPROVED: <i>David W. Bisette</i> <small>0155041E47864D1...</small>	
DATE: 21-Aug-2024	
SEAL	
	
<b>DOCUMENT NOT CONSIDERED FINAL UNLESS ALL SIGNATURES COMPLETED</b>	
PLANS PREPARED FOR THE NCDOT BY:	
<b>M</b> MOTT MACDONALD	MOTT MACDONALD 1 & E, LLC 1101 HAYNES STREET, SUITE 101 RALEIGH, NC 27604 NC LICENSE NO. F-0669

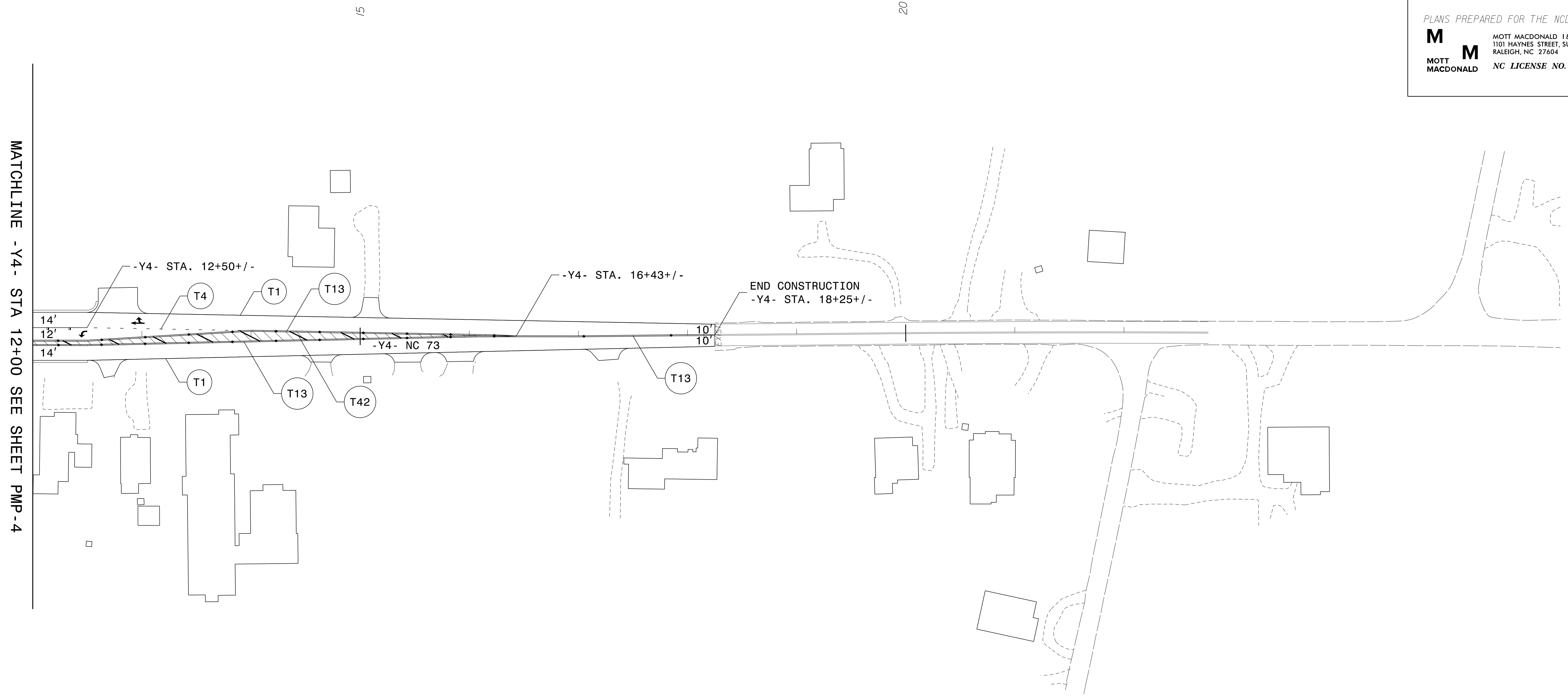
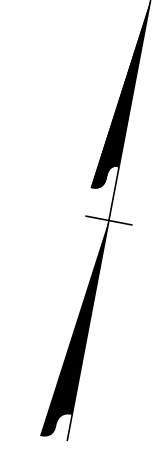

7/7/2024  
 G:\374135\_2016-plan-dsn\_LSA\proj\RA\_R-5726\Traffic\Signing\Pavement Marking R-5726\_Sgn\_PMP-23.dgn  
 User: DBIS82185

PAVEMENT MARKING DETAIL

TIP NO. R-5726	SHEET NO. PMP-24
APPROVED: <i>David W. Bisette</i> <small>Professional Engineer No. 030864</small>	
DATE: 21-Aug-2024	
SEAL 	
PLANS PREPARED FOR THE NCDOT BY: <b>M</b> MOTT MACDONALD 1 & E, LLC 1101 HAYNES STREET, SUITE 101 RALEIGH, NC 27604 <b>M</b> MOTT MACDONALD NC LICENSE NO. F-0669	

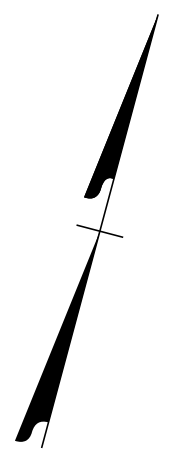

MATCHLINE -Y14- STA 13+00 SEE SHEET PMP-9

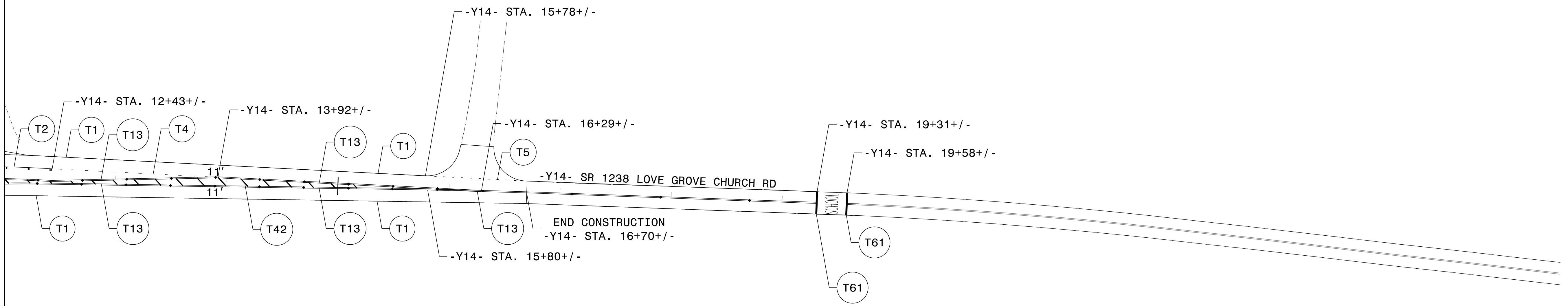

7/7/2024 10:37:19 AM G:\374195\_2016-plan-dsn\_LSA\proj\RA\_R-5726\Traffic\Signing\Pavement Marking\R-5726\_Sgn\_PMP-24.dgn User:DBIS82185

PAVEMENT MARKING DETAIL



TIP NO. R-5726	SHEET NO. PMP-25
APPROVED: <i>David W. Bisette</i> <small>0175041E47864D1...</small>	
DATE: 21-Aug-2024	
SEAL	
	
<b>DOCUMENT NOT CONSIDERED FINAL UNLESS ALL SIGNATURES COMPLETED</b>	
PLANS PREPARED FOR THE NCDOT BY: <b>M</b> MOTT MACDONALD 1 & E, LLC 1101 HAYNES STREET, SUITE 101 RALEIGH, NC 27604 <b>M</b> MOTT MACDONALD NC LICENSE NO. F-0669	

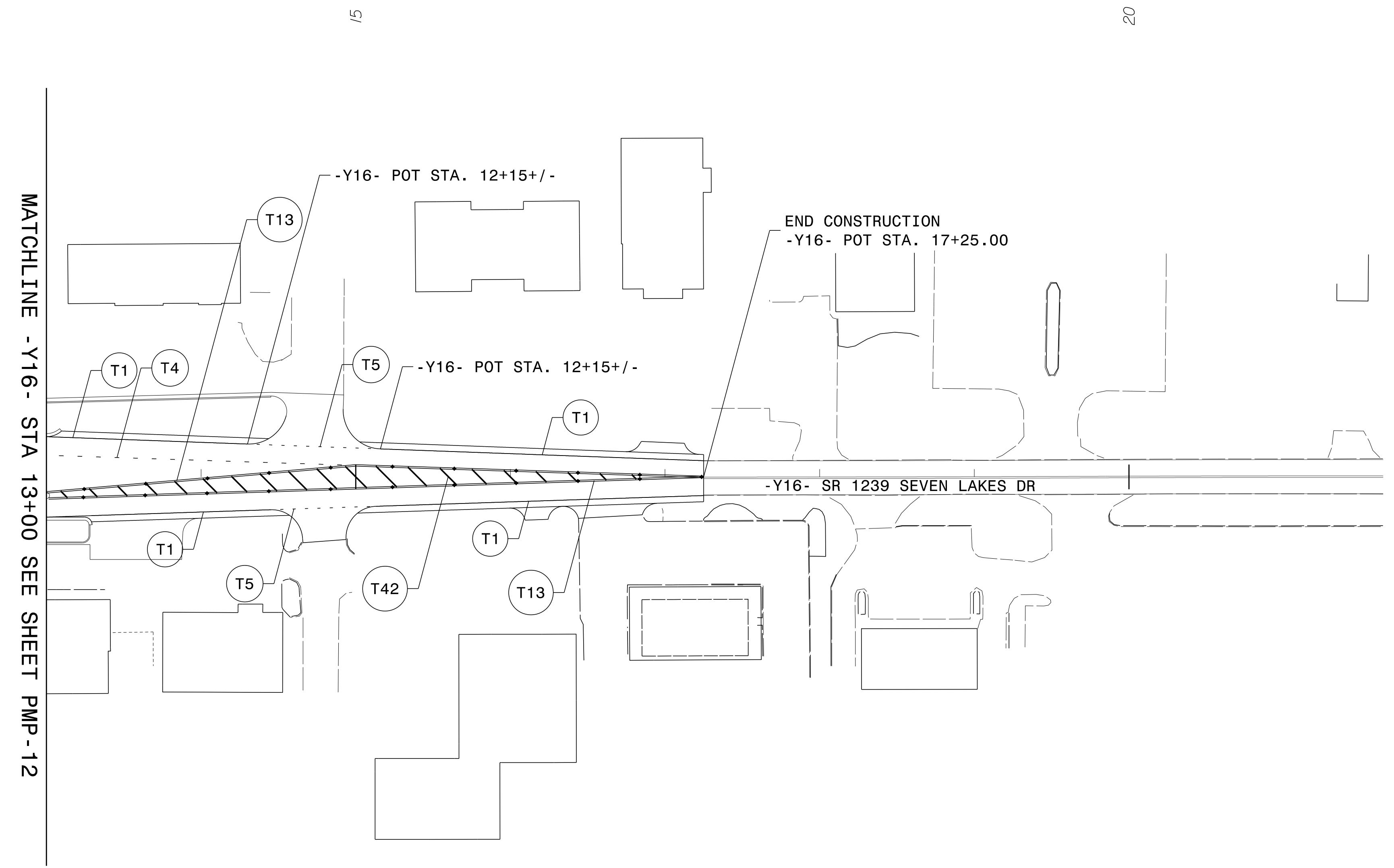
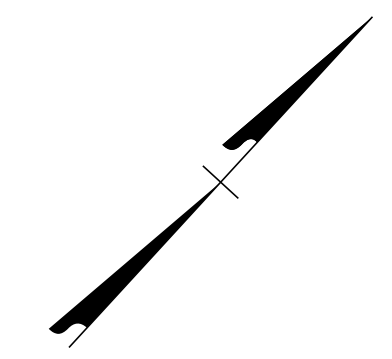

MATCHLINE -Y16- STA 13+00 SEE SHEET PMP-12

7/7/2024 10:37:19 AM G:\374195\_2016-plan-dsn\_LSA\proj\RA\_R-5726\Traffic\Signing\Pavement Marking\R-5726\_Sgn\_PMP-25.dgn User: B1582185

PAVEMENT MARKING DETAIL