

PREEMPTION PROGRAMMING

Front Panel
Main Menu >Controller >Preemption >Preempt Phasing/Preempt Parameters

Web Interface
Home >Controller >Preempt Configuration >Preempts

Preempt Configuration

Preempt	1
Enabled	Enabled
Type	Rail Road
Track Phases	4,39
Track Overlaps	-
Dwell Phases	2,6
Dwell Peds	-
Dwell Overlaps	3
Cycling Phases	-
Cycling Peds	-
Cycling Overlaps	-
Exit Phases	4
Exit Overlaps	-
Delay	0
Call Ext Time	1.0
Max Presence	0
Max Pres Act	Terminate
Enter Min Green	1
Enter Walk	0
Enter Ped Clear	0
Enter Yellow Change	4.7
Enter Red Clear	2.9
Track Green	22
Track Yellow Clr	3.2
Track Red Clear	2.0
Dwell Green	0
Exit Min Green	255
Exit Yellow Change	25.5
Exit Red Clear	25.5
Exit Type	Exit Phases
Non Locking Memory	-
Not Ovrd Flash	X
Not Ovrd Nxt Pre	-
Require All Red Entry	-
Track Clear Ovrd	X
Ped Clear During Yellow	-
Entry Omit OLTG	X
Track Reserve	X

RAILROAD PREEMPTION WIRING DETAIL

(wire as shown below)

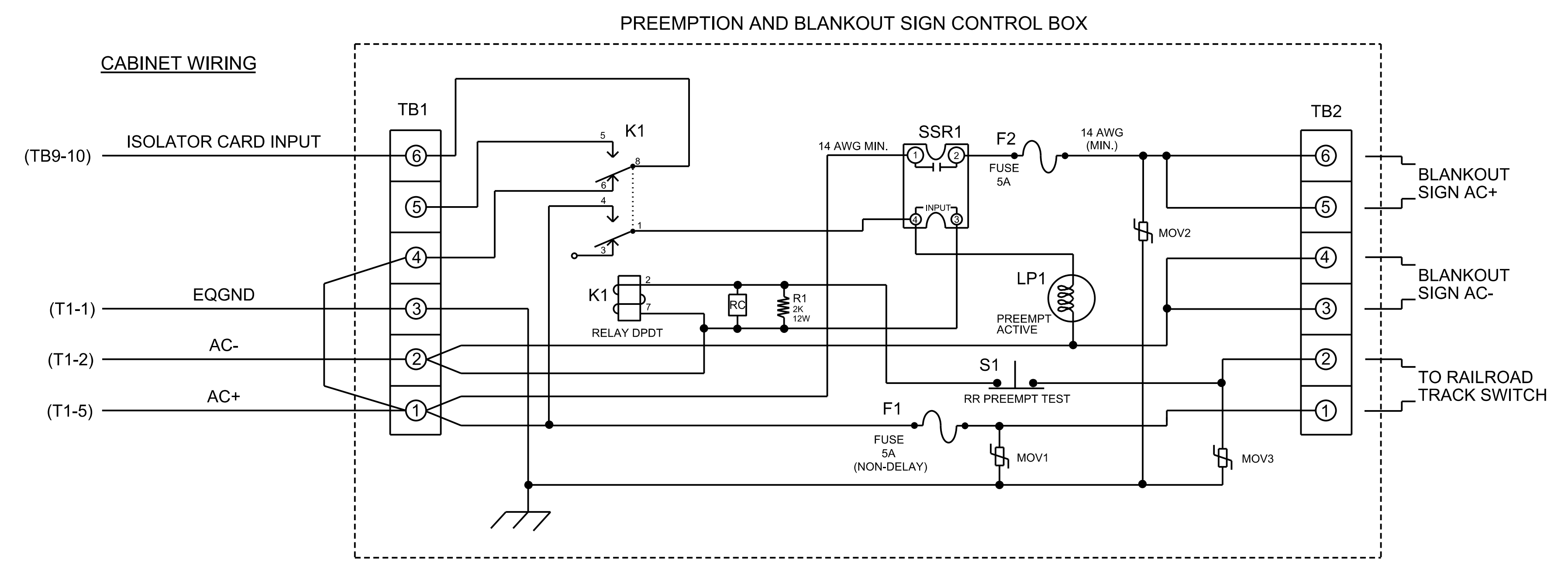

NOTES

- Relay K1 is shown in the energized (Preempt not active) normal operation state.
- Relay K1 is a DPDT with 120VAC coil with octal base.
- Relay SSR1 is a SPST (normally open) Solid State Relay with AC input and AC (25 amp) output.
- AC Isolator Card shall activate preemption upon removal of AC+ from the input (as shown above). To accomplish this set invert dip switch on AC Isolator Card.
- IMPORTANT!!** A jumper must be added between input file terminals J14-E and J14-K if not already present. Also, terminal TB9-12 (on input panel) shall be connected to AC neutral (jumper may have to be added).

FRONT VIEW

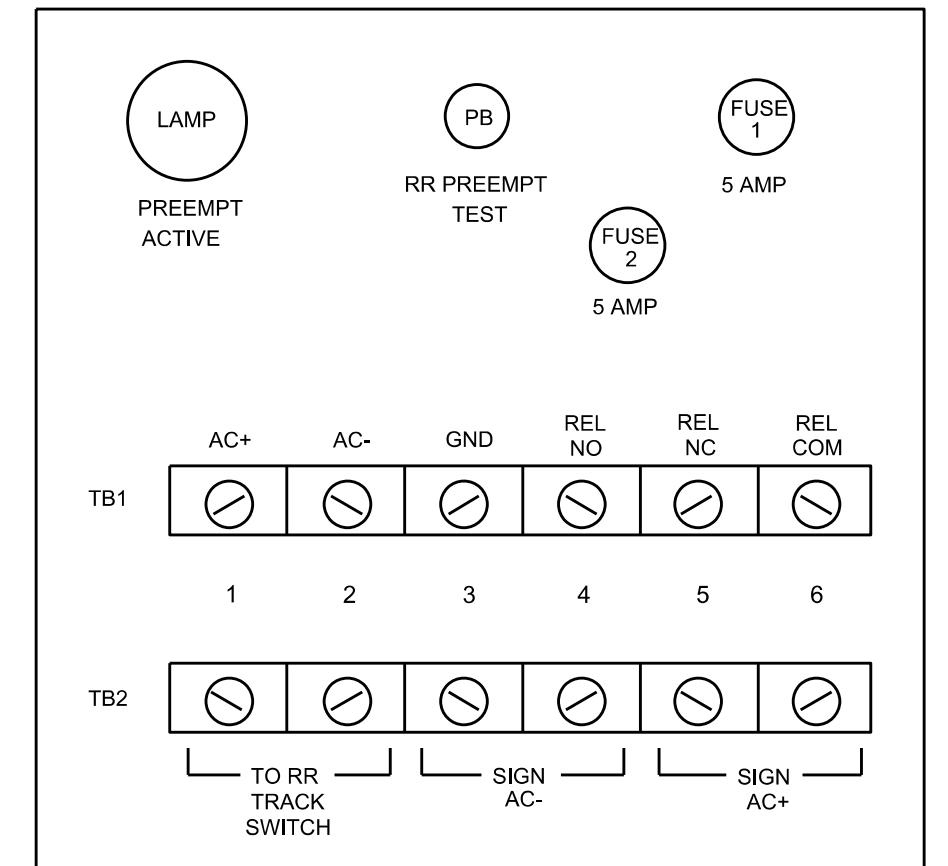

SEQUENCE DETAIL

Front Panel
Main Menu >Controller >Sequence & Phs Config>Sequences

Web Interface
Home >Controller >Sequence

Sequence 1

Ring	Sequence Data
1	1,2,a,3,4,b
2	5,6,a,7,8,b
3	39,c,40,d

PREEMPT 1 AC ISOLATOR (MODEL 252) OUTPUT PROGRAMMING DETAIL

(set DIP switches as shown below)

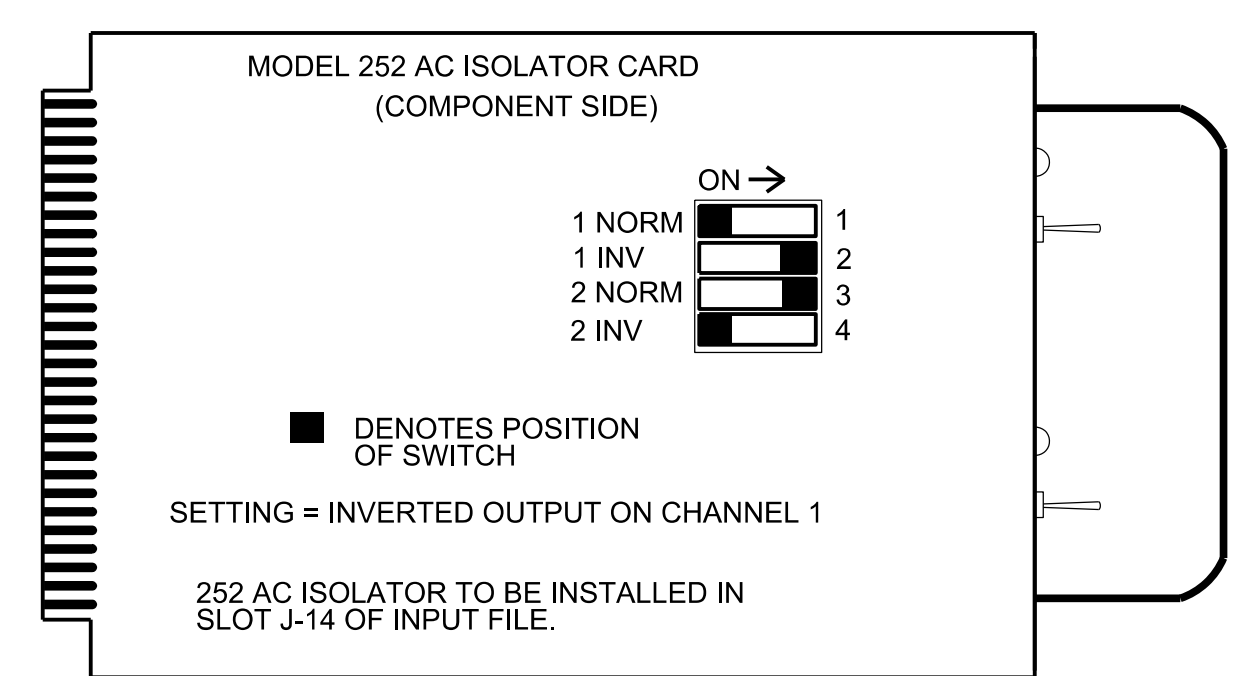

THIS ELECTRICAL DETAIL IS FOR THE SIGNAL DESIGN: 08-0410T2
DESIGNED: June 2024
SEALED: 7/11/2024
REVISED:

Electrical Detail - Sheet 3 of 3
Temporary Design 2 (TMP Phase II)

M M
MOTT MACDONALD
MOTT MACDONALD I & E, LLC
930 Main Campus Drive
Suite 200
RALEIGH, NC 27606
License No. F-0669

ELECTRICAL AND PROGRAMMING DETAILS FOR:
Prepared for:

750 N. Greenfield Pkwy, Corner, NC 27529

NC 211
at
SR 1239 (Seven Lakes Drive)
and SR 1190 (Lakeway Drive)
Division 8 Moore County Seven Lakes
PLAN DATE: June 2024 REVIEWED BY: R. Mullinax
PREPARED BY: LD Stouchko REVIEWED BY:
REVISIONS INIT. DATE

DOCUMENT NOT CONSIDERED FINAL UNLESS ALL SIGNATURES COMPLETED

SEAL
NORTH CAROLINA PROFESSIONAL ENGINEER
SEAL 034437
LD STOUCHKO
Lori D. Stouchko
DATE
SIG. INVENTORY NO. 08-0410T2