

18 CHANNEL CONFLICT MONITOR PROGRAMMING DETAIL

(remove jumpers and set switches as shown)

REMOVE DIODE JUMPERS 1-6, 1-9, 1-11, 2-6, 2-9, 2-11, 2-12, 4-12, 6-9, 6-11, 6-12, 9-11, 9-12, and 11-12.

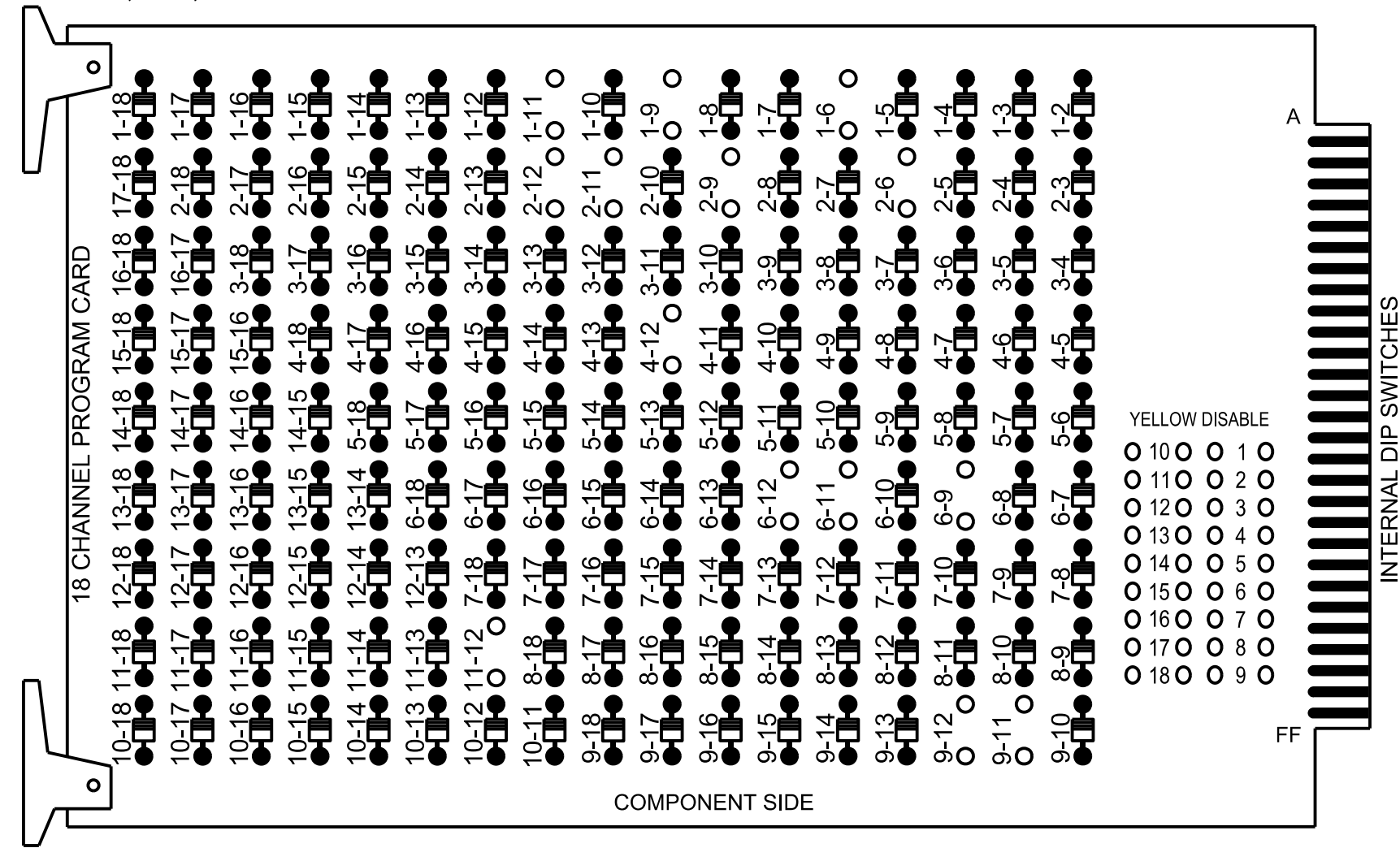

REMOVE JUMPERS AS SHOWN

NOTES:

- Card is provided with all diode jumpers in place. Removal of any jumper allows its channels to run concurrently.
- Ensure jumpers SEL2-SEL5 and SEL9 are present on the monitor board.
- Ensure that the Red Enable is active at all times during normal operation.
- Connect serial cable from conflict monitor to comm. port 1 of 2070 controller. Ensure conflict monitor communicates with 2070.

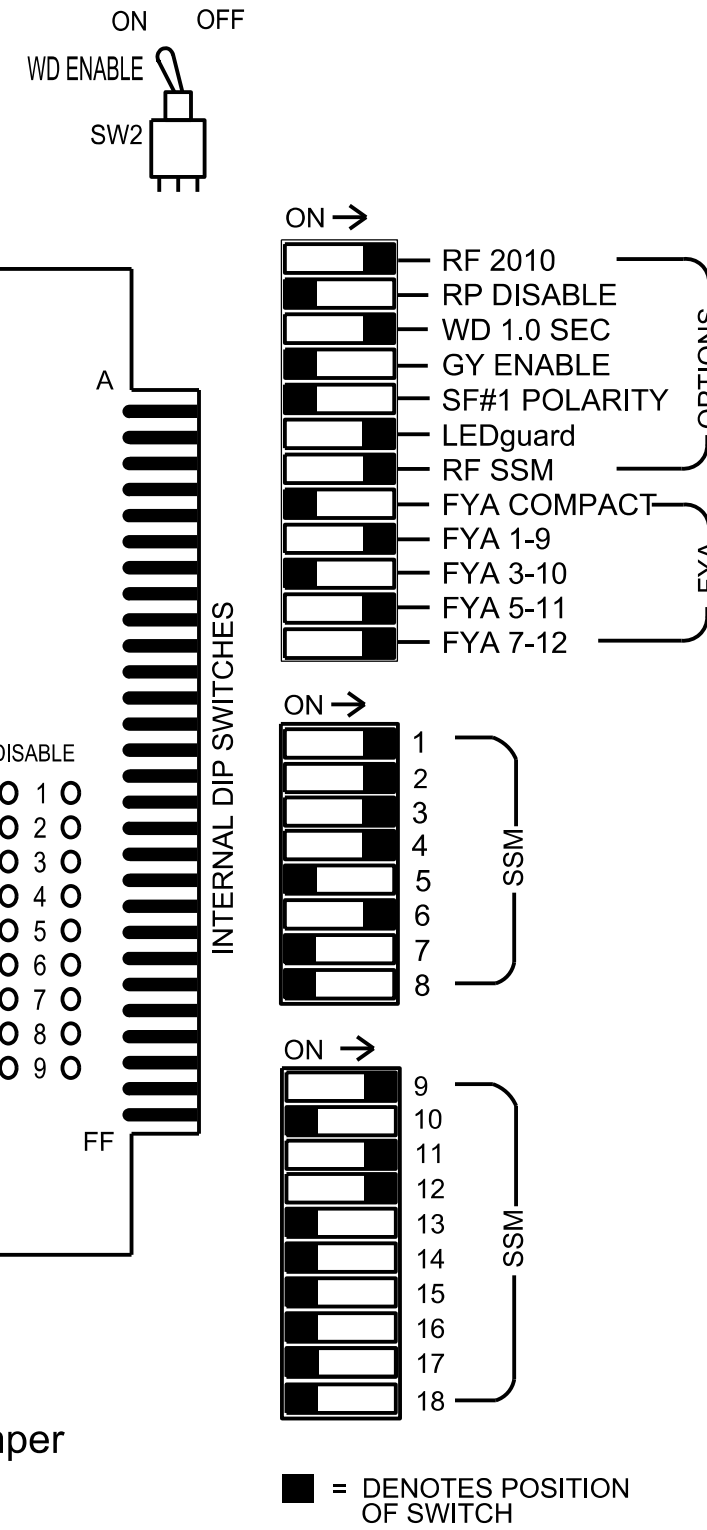

NOTES

- To prevent "flash-conflict" problems, insert red flash program blocks for all unused vehicle load switches in the output file. The installer shall verify that signal heads flash in accordance with the signal plan.
- Program controller to start up in phase 2 Green No Walk, 6 Green No Walk, 39 Phase Not On, and 40 Green No Walk.
- Program Phase 39 for No Startup Veh Call.
- Program Phase 40 for Min Recall.
- If this signal will be managed by an ATMS software, enable controller and detector logging for all detectors used at this location.

EQUIPMENT INFORMATION

Controller.....2070LX
 Cabinet.....332 w/ Aux
 Software.....Q-Free MAXTIME
 Cabinet Mount.....Base
 Output File Positions.....18 With Aux. Output File
 Load Switches Used.....S1, S2, S4, S5, S8, AUX S1, AUX S4, AUX S5
 Phases Used.....1, 2, 3, 4, 6, 39**, 40**
 Overlap "1".....*
 Overlap "2".....NOT USED
 Overlap "3".....*
 Overlap "4".....*

*See overlap programming detail on sheet 2
 **Phase used for preemption timing purposes only

SIGNAL HEAD HOOK-UP CHART

LOAD SWITCH NO.	S1	S2	S3	S4	S5	S6	S7	S8	S9	S10	S11	S12	AUX S1	AUX S2	AUX S3	AUX S4	AUX S5	AUX S6
CMU CHANNEL NO.	1	2	13	3	4	14	5	6	15	7	8	16	9	10	17	11	12	18
PHASE	1	2	2 PED	3	4	4 PED	5	6	6 PED	7	8	8 PED	OL1	OL2	SPARE	OL3	OL4	SPARE
SIGNAL HEAD NO.	11	42	21,22	31	32	41	42,43	NU	61,62	NU	NU	NU	11	NU	NU	24	23	NU
RED	*	128		116	116	101	101		134									A101
YELLOW		129		117	117	102	102		135									
GREEN		130		118	118	103	103		136									
RED ARROW													A121					A114
YELLOW ARROW		126											A122					A115 A102
FLASHING YELLOW ARROW													A123					A116 A103
GREEN ARROW	127	127		118	103													

NU = Not Used
 * Denotes install load resistor. See load resistor installation detail this sheet.
 * See pictorial of head wiring in detail this sheet.

FYA SIGNAL WIRING DETAIL

(wire signal heads as shown)

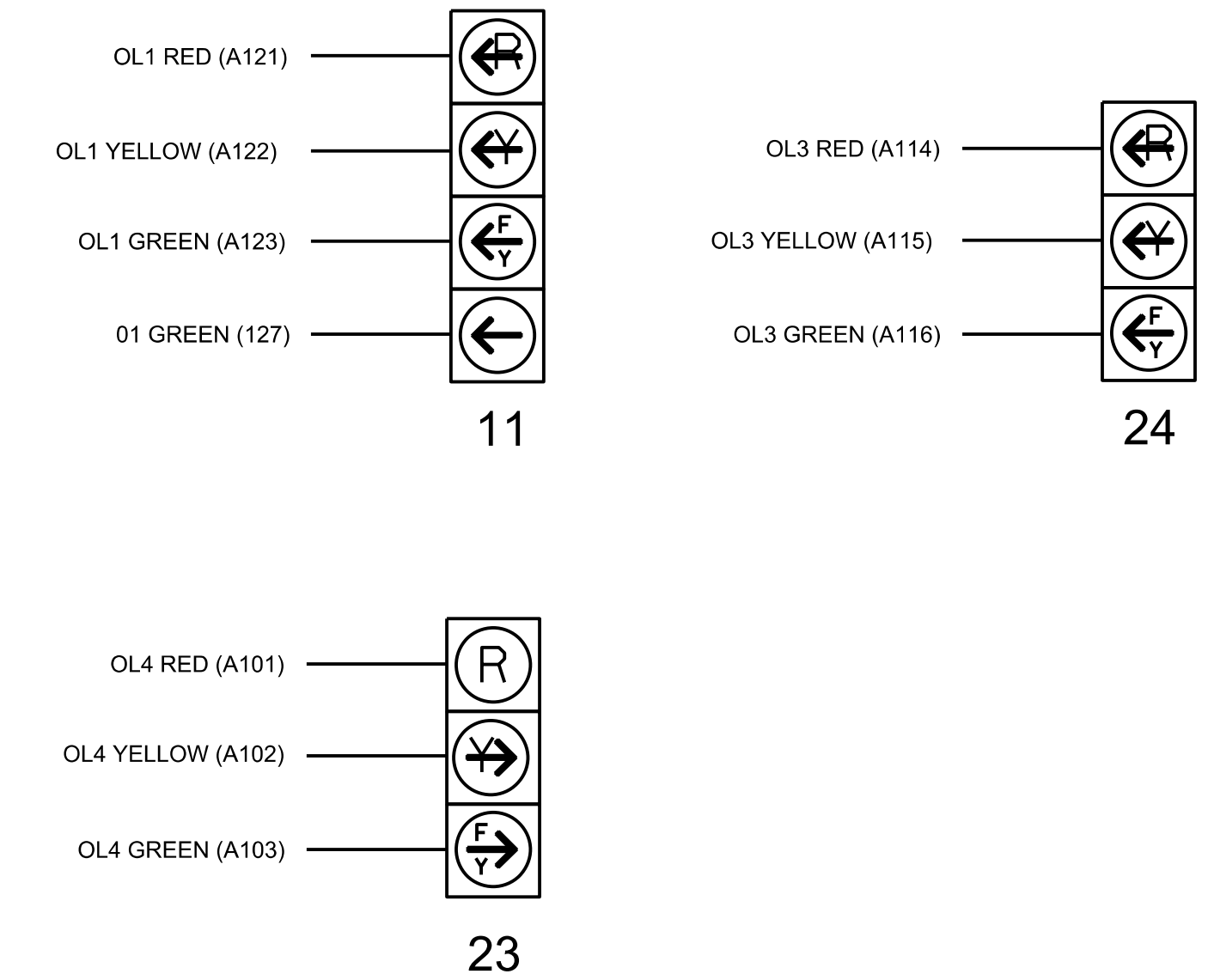

THIS ELECTRICAL DETAIL IS FOR THE SIGNAL DESIGN: 08-1103T3
 DESIGNED: June 2024
 SEALED: 7/11/2024
 REVISED:

INPUT FILE POSITION LAYOUT

(front view)

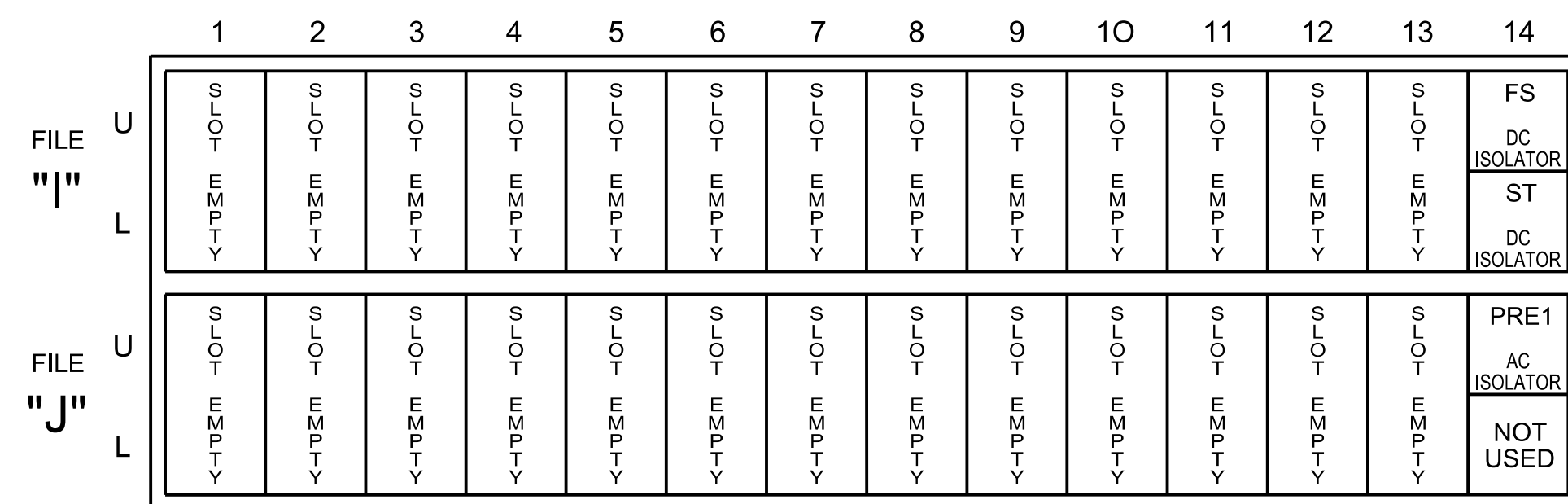

EX.: 1A, 2A, ETC. = LOOP NO.'S

FS = FLASH SENSE
 ST = STOP TIME
 PRE = PREEMPT

SPECIAL DETECTOR NOTES

Install a video detection system for vehicle detection. Perform installation according to manufacturer's directions and NCDOT engineer-approved mounting locations to accomplish the detection schemes shown on the Signal Design Plans.

LOAD RESISTOR INSTALLATION DETAIL

(install resistors as shown)

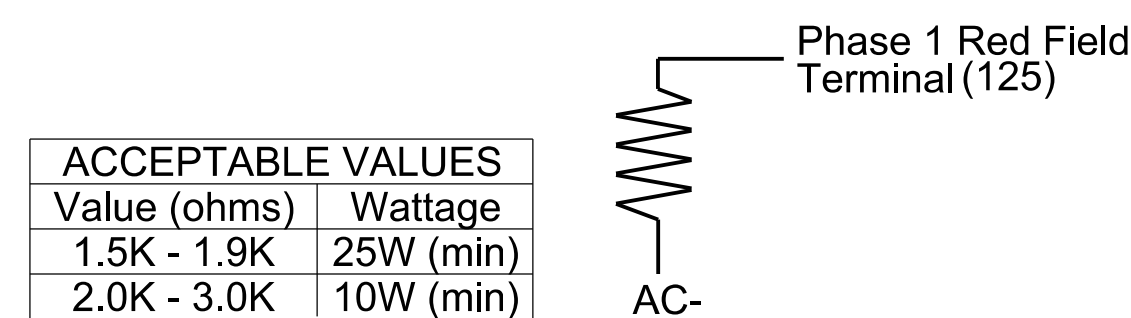

ACCEPTABLE VALUES	
Value (ohms)	Wattage
1.5K - 1.9K	25W (min)
2.0K - 3.0K	10W (min)

Electrical Detail - Sheet 1 of 3
 Temporary Design 3 (TMP Phase III)

DOCUMENT NOT CONSIDERED FINAL UNLESS ALL SIGNATURES COMPLETED

M M
MOTT MACDONALD
 MOTT MACDONALD I & E, LLC
 930 Main Campus Drive
 Suite 200
 RALEIGH, NC 27606
 License No. F-0669

Prepared for:

 750 N. Greenfield Pkwy, Corner, NC 27529

NC 211/NC 73-211
 at
 NC 73 (South Intersection)
 Division 8 Moore County West End
 PLAN DATE: June 2024 REVIEWED BY: R. Mullinax
 PREPARED BY: LD Stouchko REVIEWED BY:
 REVISIONS INIT. DATE

SEAL
 NORTH CAROLINA PROFESSIONAL ENGINEER
 SEAL 034437
 LD STOUCHKO
 DATE

SIG. INVENTORY NO. 08-1103T3