

PROJECT REFERENCE NO.	SHEET NO.
R-5921	EC-28/CONST.5
RW SHEET NO.	
ROADWAY DESIGN ENGINEER	HYDRAULICS ENGINEER
 TGS ENGINEERS 201 W. MARION ST-STE 200 SHELBY, NC 28150 PH (704) 476-0003 CORP. LICENSE NO.: C-0275	

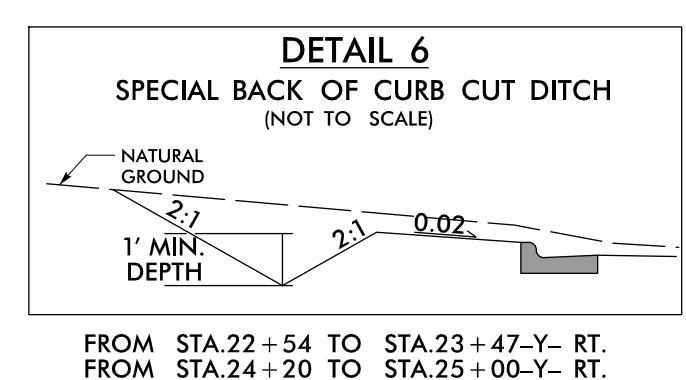

MATCH LINE STA -Y- 21+00.00
MATCH TO SHEET NO. 4

-Y- STA. 26+00.00
END CONSTRUCTION

CONTRACTOR IS TO CONNECT EXISTING FRENCH DRAIN ON PARCEL 08 TO NEAREST PROPOSED DRAINAGE STRUCTURE. NO ADDITIONAL COMPENSATION WILL BE GIVEN FOR THIS WORK.

IN LIEU OF ROCK INLET SEDIMENT TRAP, UTILIZE FABRIC INSERT INLET PROTECTION OR OTHER APPROVED DEVICE IN AREAS WHERE WATER MAY POND ON ROAD OPEN TO LIVE TRAFFIC.