

FROM STA. 13+56 TO STA. 15+25 -L- (LT)
 FROM STA. 15+25 TO STA. 17+00 -L- (LT)
 FROM STA. 54+00 TO STA. 56+50 -L- (RT)
 FROM STA. 56+50 TO STA. 57+50 -L- (RT)

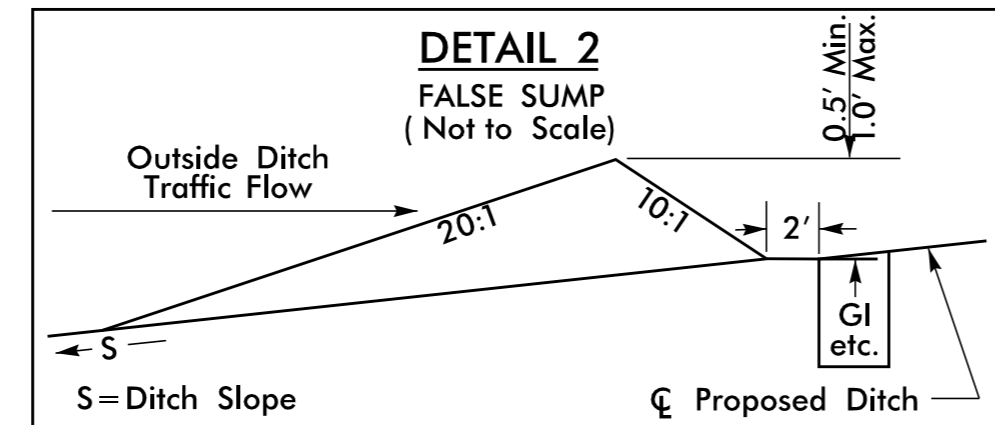

STA. 26+68 -L- (LT)
 STA. 30+28 -L- (RT)

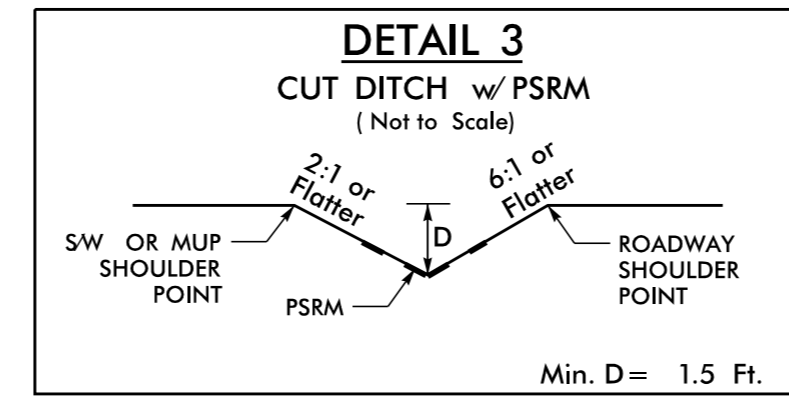

FROM STA. 38+00 TO STA. 42+40 -L- (LT)

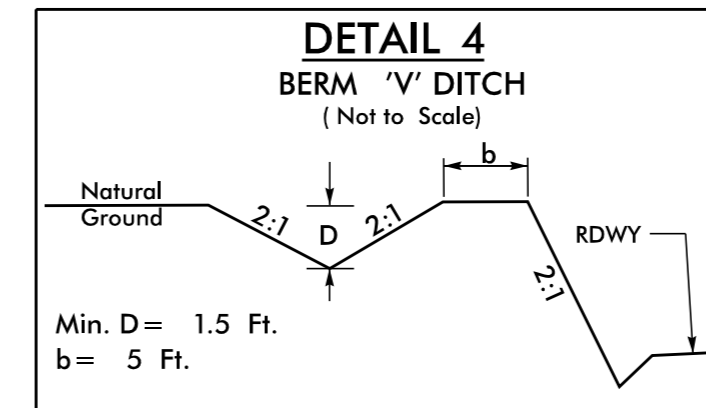

FROM STA. 25+00 TO STA. 28+70 -L- (RT)
 FROM STA. 28+70 TO STA. 30+00 -L- (RT)
 FROM STA. 30+00 TO STA. 30+40 -L- (RT)
 FROM STA. 51+50 TO STA. 54+00 -L- (RT)

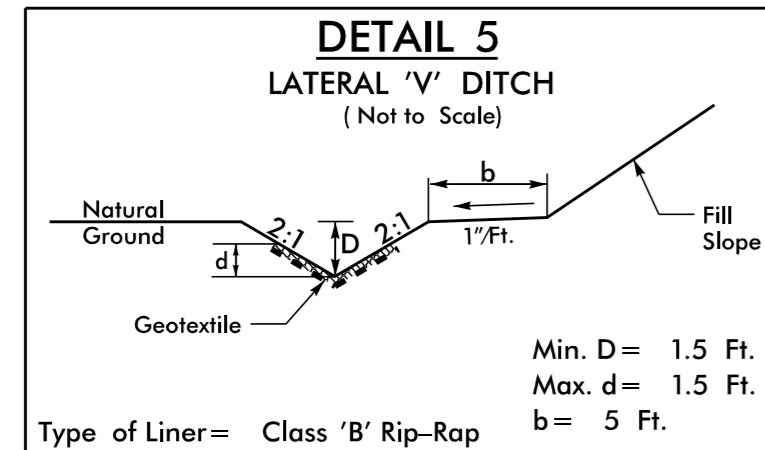

FROM STA. 42+00 TO STA. 43+60 -L- (RT)
 FROM STA. 42+75 TO STA. 43+55 -L- (LT)
 FROM STA. 43+75 TO STA. 44+75 -L- (RT)
 FROM STA. 43+67 TO STA. 45+50 -L- (LT)

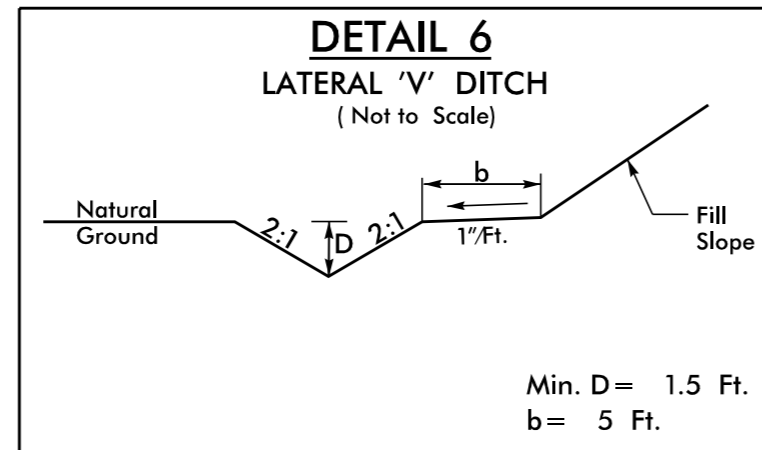

FROM STA. 57+75 TO STA. 59+85 -L- (LT)

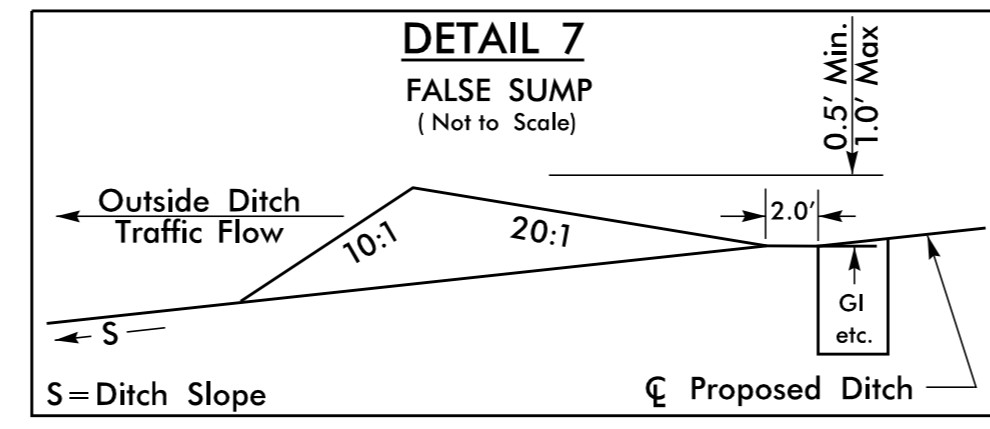

STA. 30+28 -L- (LT)
 STA. 36+15 -L- (RT)

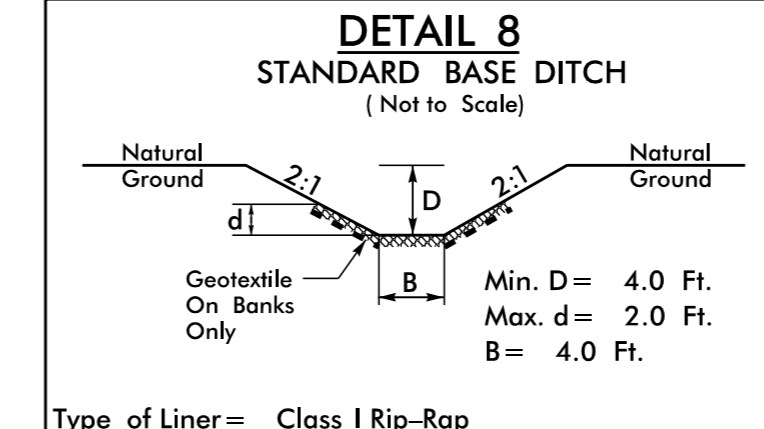

STA. 60+50 -L- (RT)

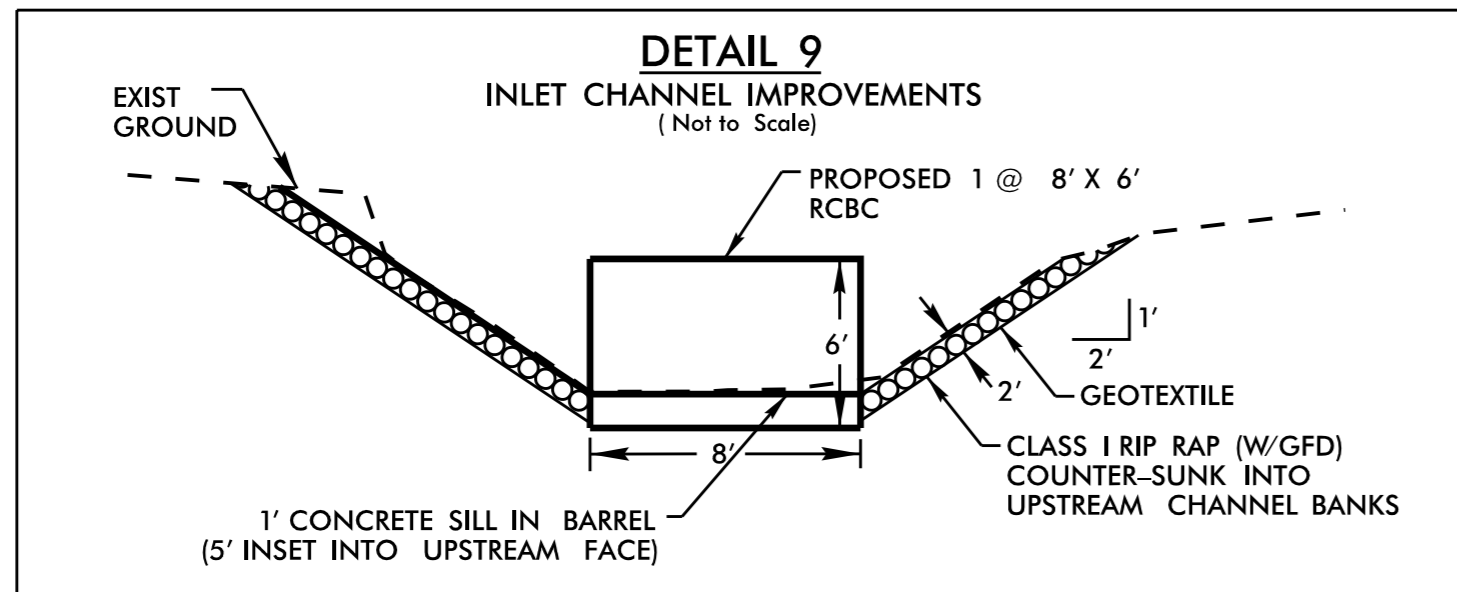

STA. 43+70 -L- (RT)

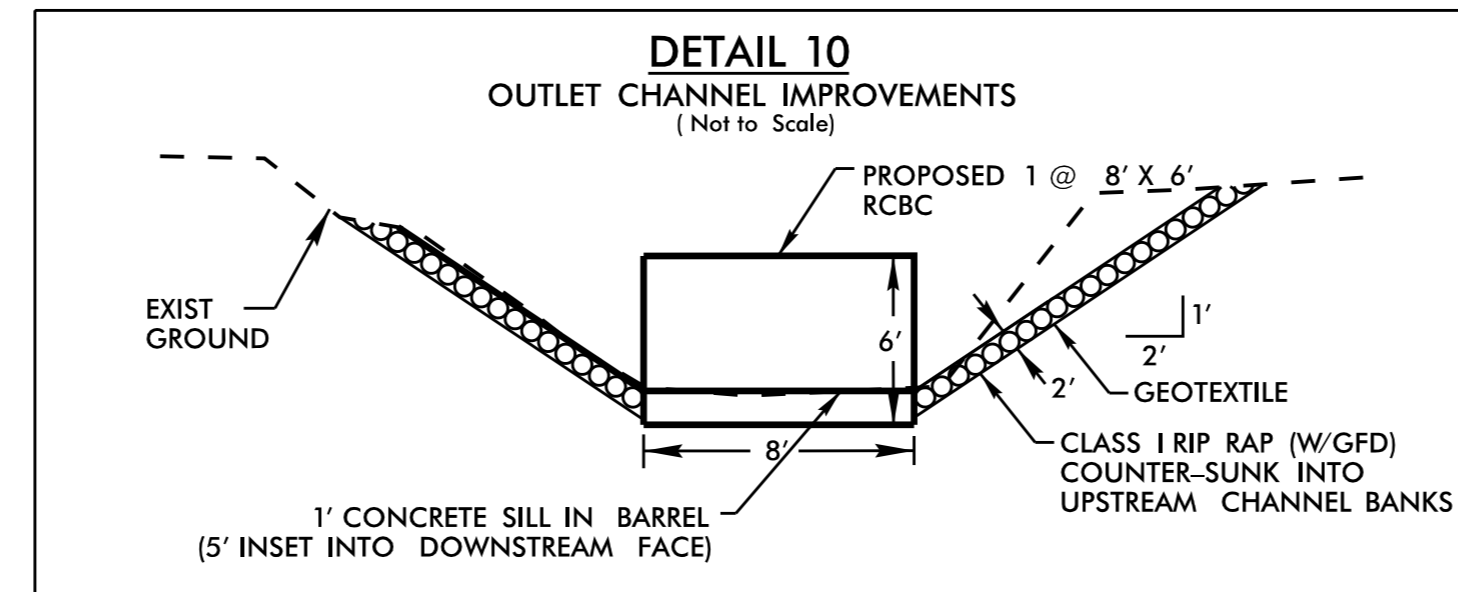

STA. 43+55 -L- (LT)

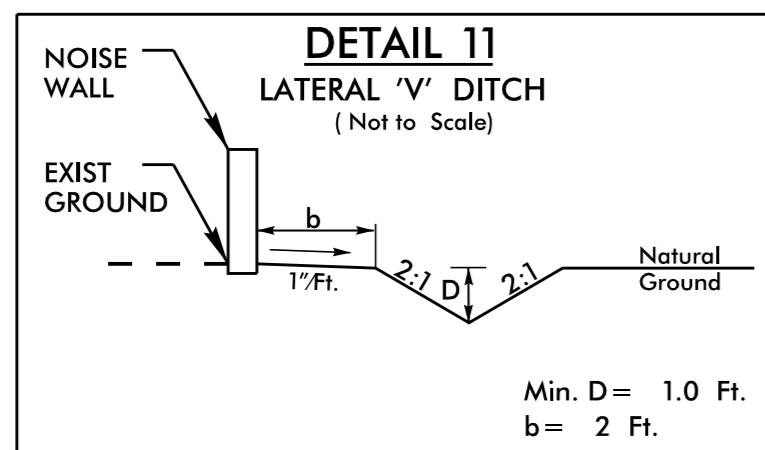

FROM STA. 30+40 TO STA. 34+50 -L- (RT)
 FROM STA. 34+50 TO STA. 35+95 -L- (RT)
 FROM STA. 35+95 TO STA. 37+50 -L- (RT)
 FROM STA. 37+50 TO STA. 40+25 -L- (RT)