

09.08/99
 6/13/2024
 \\gd.rkk.com\fs\Cloud\Projects\2016\6215_U01\SA\A01\R-2307B\Utilities\Engineering\UBO\Proj\R-2307B_ut_tsh_U01.psh.dgn

CONTRACT: TIP PROJECTS: R-2307B & I-5717

STATE OF NORTH CAROLINA
DIVISION OF HIGHWAYS

**UTILITIES BY OTHERS PLANS
CATAWBA & IREDELL COUNTIES**

T.I.P. NO.	SHEET NO.
R-2307B & I-5717	UO-1

NOTE:
ALL UTILITY WORK SHOWN ON THIS SHEET IS DONE BY OTHERS.
NO PAYMENT WILL BE MADE TO THE CONTRACTOR FOR UTILITY WORK SHOWN ON THIS SHEET.

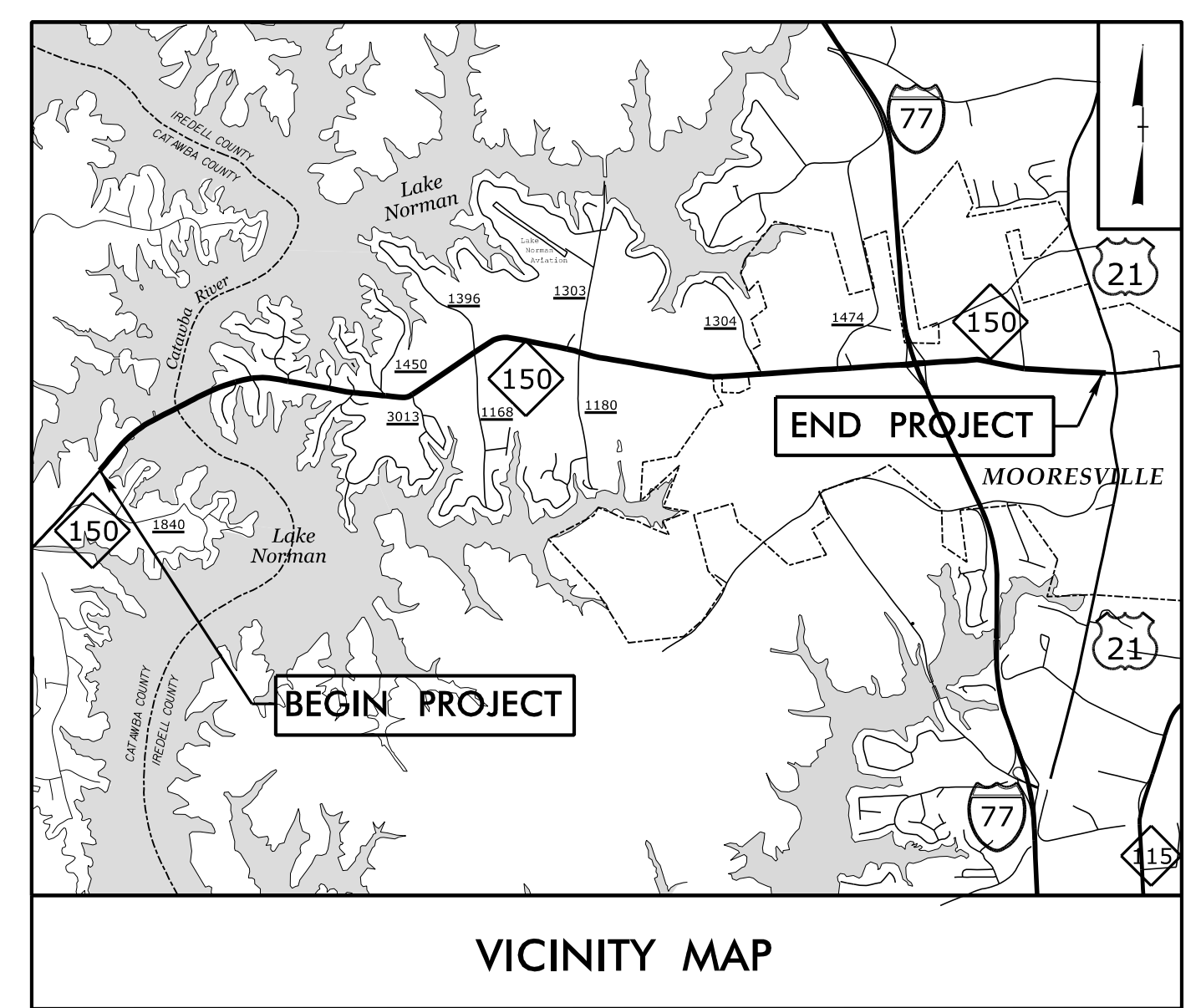

LOCATION: NC 150 FROM SR 1840 (GREENWOOD RD) IN CATAWBA COUNTY TO US 21 IN IREDELL COUNTY
TYPE OF WORK: AERIAL AND UNDERGROUND POWER AND TELECOMMUNICATIONS WORK. UNDERGROUND NATURAL GAS WORK.

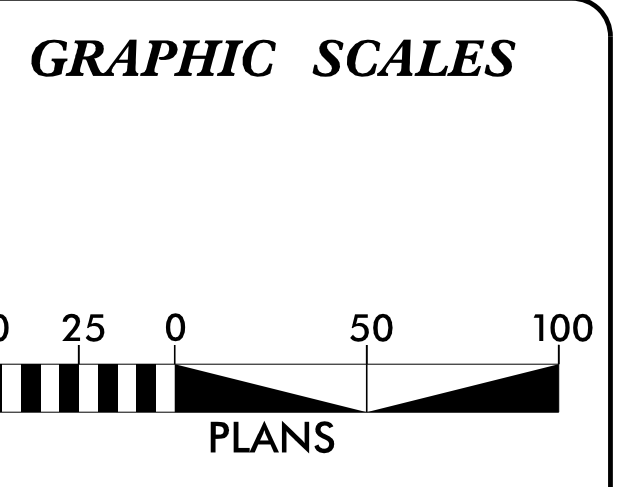
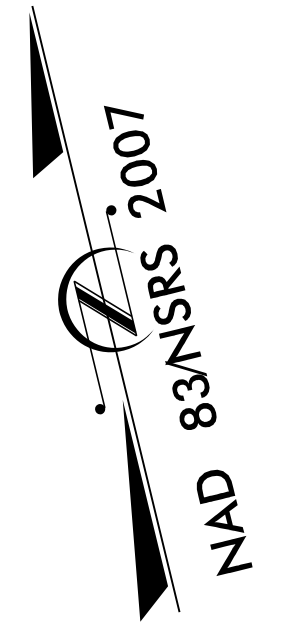
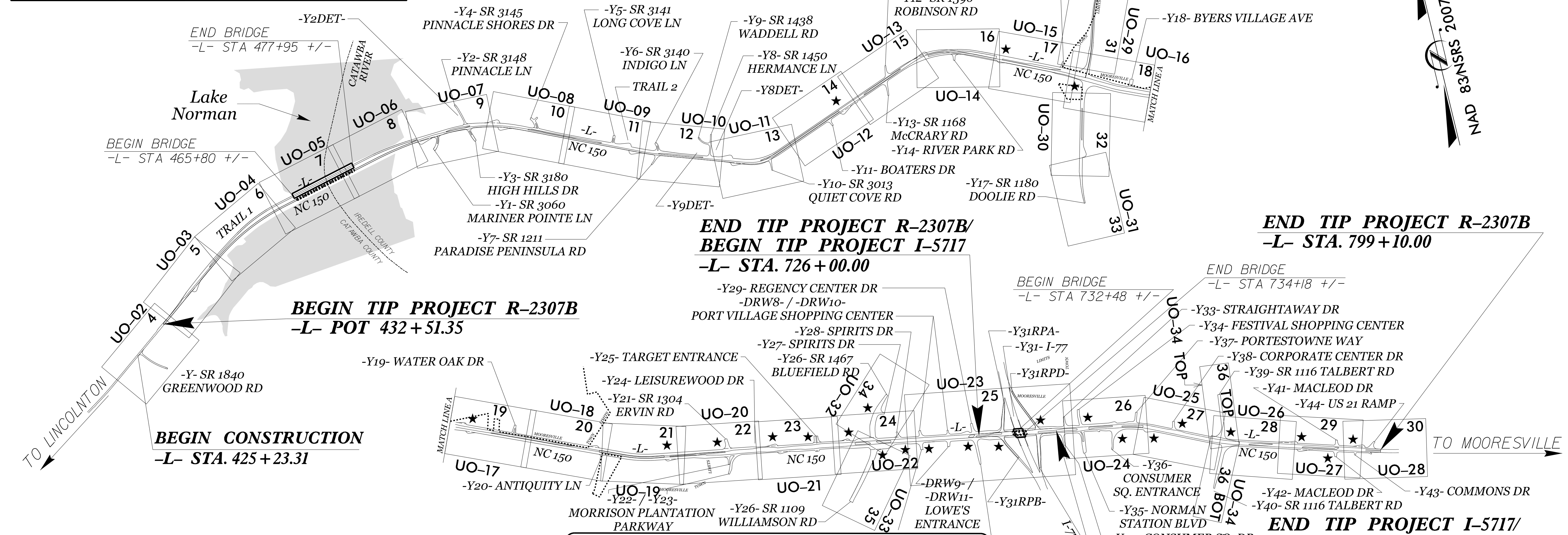

INDEX OF SHEETS

SHEET NO.:	DESCRIPTION:
UO-1	TITLE SHEET
UO-02 THRU UO-34	UBO PLAN SHEETS

UTILITY OWNERS WITH CONFLICTS

- (A) DUKE ENERGY - POWER (TRANS)
- (B) DUKE ENERGY - POWER (DIST)
- (C) ENERGY UNITED COOP - POWER (DIST)
- (D) DOMINION ENERGY (PSNC) - NATURAL GAS
- (E) WINDSTREAM - TELECOMMUNICATIONS
- (F) BRIGHTSPEED - TELECOMMUNICATIONS
- (G) AT&T - TELECOMMUNICATIONS
- (H) TDS COMMUNICATIONS - COMMUNICATIONS
- (I) MCI /VERIZON - COMMUNICATIONS
- (J) SEGRA COMMUNICATIONS - COMMUNICATIONS (SPIRIT)
- (K) LUMEN - COMMUNICATIONS
- (L) CONTERRA ULTRA BROADBAND - COMMUNICATIONS
- (M) (M) CHARTERSPECTRUM - CATV
- (N) NCDOT TRAFFIC - FIBER OPTIC

PREPARED IN THE OFFICE OF:

P: (919) 878-9560
8601 Six Forks Road, Forum 1, Suite 700
Raleigh, North Carolina 27615-3960
NC License No. F-0112

Engineers | Construction Managers | Planners | Scientists
www.rkk.com

Responsive People | Creative Solutions

Richy Narron UTILITY PROJECT MANAGER
Mark Lawson PROJECT UTILITY COORDINATOR
Mark Lawson PROJECT UTILITY COORDINATOR CADD

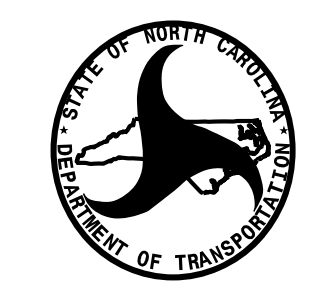

**DIVISION OF HIGHWAYS
UTILITIES UNIT**
1555 MAIL SERVICES CENTER
RALEIGH, NC 27699-1555
PHONE (919) 707-6690
FAX (919) 250-4151

Amy York WESTERN UTILITIES MANAGER
Donald Hampton REGIONAL UTILITIES ENGINEER
XXXX REGIONAL UTILITY COORDINATOR
Steve Trexler UTILITIES COORDINATOR

UTILITIES BY OTHERS

ALL PROPOSED UTILITY WORK SHOWN ON THIS SHEET WILL BE DONE BY OTHERS. NO PAYMENT WILL BE MADE TO THE CONTRACTOR FOR PROPOSED UTILITY WORK SHOWN ON THIS SHEET.

TGS ENGINEERS
706 HILLSBOROUGH ST., SUITE 200
RALEIGH, NC 27603
PH (919) 773-8887
CORP. LICENSE NO.: C-0275

JETEN PROPERTIES LLC
DB 2280 PG 1480
PB 52 PG 79

JETEN PROPERTIES LLC
DB 2271 PG 945

DUKE ENERGY CAROLINAS LLC
DB 1620 PG 232

ANNIE & CLYDE HOLDSCLAW, HEIRS
DB 1598 PG 821

MITCHELL LEWIS PARKER
DB 1066 PG 444

EVELYN G. STUTTS REVOCABLE TRUST
DB 3237 PG 1970

MATTIE ROSE DEVELOPMENT INC
DB 3211 PG 1384
PB 66 PG 178

HAROLD EDWIN STUTTS
DB 1206 PG 370 & 371

DUKE ENERGY CAROLINAS LLC
DB 2954 PG 421

DUKE ENERGY CAROLINAS LLC
DB 2954 PG 421

DUKE ENERGY CAROLINAS LLC
DB 2954 PG 421

DUKE ENERGY CAROLINAS LLC
DB 2954 PG 421

DUKE ENERGY CAROLINAS LLC
DB 2954 PG 421

DUKE ENERGY CAROLINAS LLC
DB 2954 PG 421

DUKE ENERGY CAROLINAS LLC
DB 2954 PG 421

DUKE ENERGY CAROLINAS LLC
DB 2954 PG 421

- NOTE:
1. ALL EXISTING OVERHEAD POWER ROUTING/ CONNECTIVITY PROVIDED BY; DUKE ENERGY AND GOOGLE EARTH. ALL EXISTING DUKE ENERGY POWER IN CONFLICT WILL BE WRECKED OUT
 2. ALL EXISTING UNDERGROUND TELECOMMUNICATIONS AND POWER IN CONFLICT WITH THE PROJECT WILL BE ABANDONED IN PLACE

UTILITY OWNERS ON THIS SHEET

DUKE POWER - POWER (D)
ENERGY UNITED COOP - POWER (D)
WINDSTREAM - TELECOMMUNICATIONS
BRIGHTSPEED - TELECOMMUNICATIONS
SPECTRUM - CATV

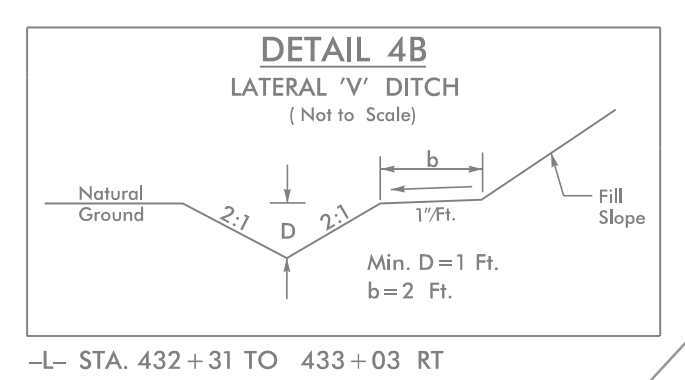
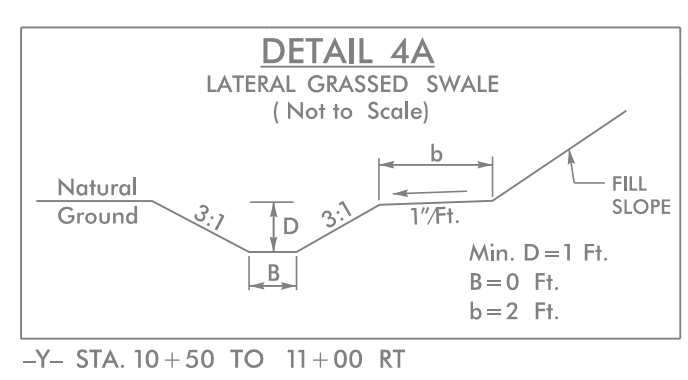
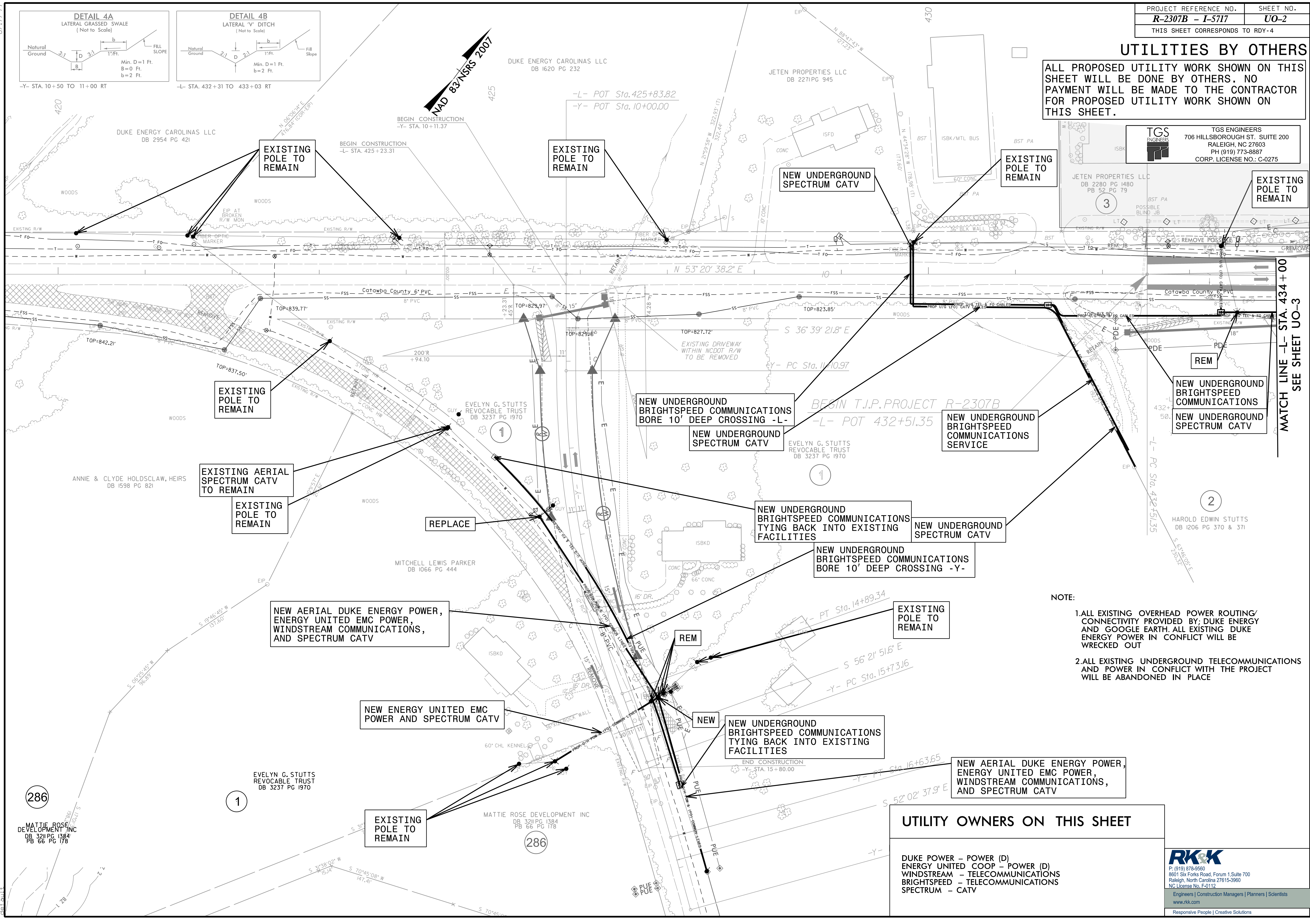

6/17/2024
C:\Users\mattie\OneDrive\Documents\Projects\2016\162115_UO1_SAY_A01_R-2307B\Utilities\Engineering\UB00\ProJ\NR-2307B\ut.Rdy04_U002_psh.dgn

MATCH LINE -L- STA. 434+00
SEE SHEET UO-3

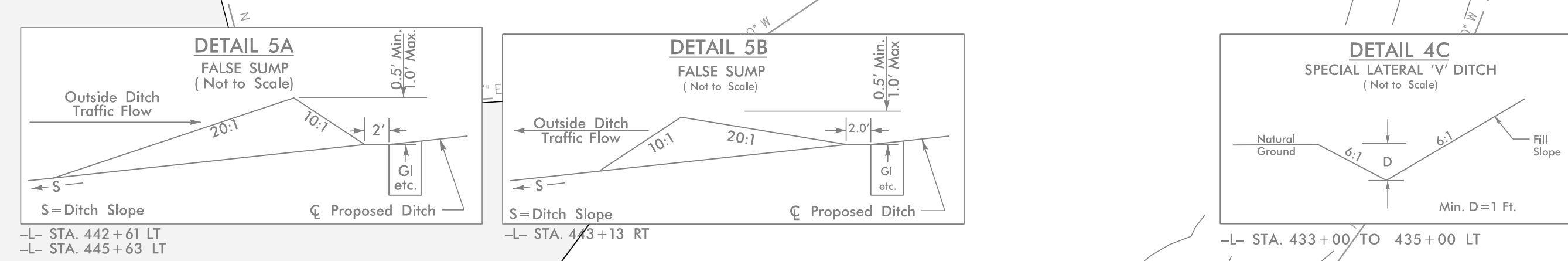

**NEW AERIAL DUKE ENERGY POWER,
WINDSTREAM COMMUNICATIONS,
AND SPECTRUM CATV**

UTILITIES BY OTHERS

ALL PROPOSED UTILITY WORK SHOWN ON THIS SHEET WILL BE DONE BY OTHERS. NO PAYMENT WILL BE MADE TO THE CONTRACTOR FOR PROPOSED UTILITY WORK SHOWN ON THIS SHEET.

TGS ENGINEERS
706 HILLSBOROUGH ST., SUITE 200
RALEIGH, NC 27603
PH (919) 773-8887
CORP. LICENSE NO.: C-0275

MATCH LINE -L- STA. 434+00
SEE SHEET UO-2

MATCH LINE -L- STA. 448+00
SEE SHEET UO-4

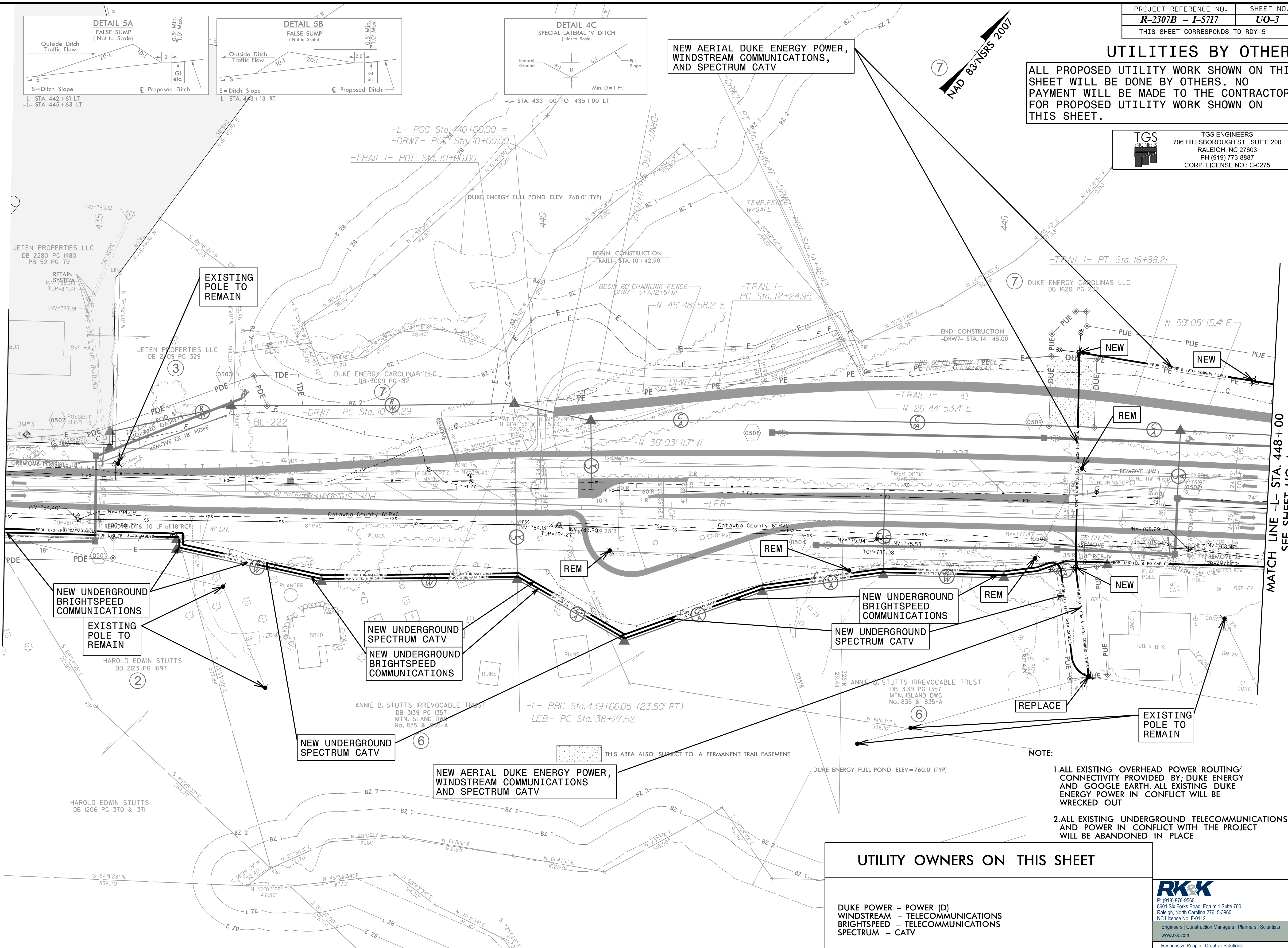

NEW UNDERGROUND SPECTRUM CATV

NEW UNDERGROUND BRIGHTSPEED COMMUNICATIONS

EXISTING POLE TO REMAIN

NEW UNDERGROUND SPECTRUM CATV
NEW UNDERGROUND BRIGHTSPEED COMMUNICATIONS

NEW UNDERGROUND SPECTRUM CATV

NEW UNDERGROUND BRIGHTSPEED COMMUNICATIONS

EXISTING POLE TO REMAIN

**NEW AERIAL DUKE ENERGY POWER,
WINDSTREAM COMMUNICATIONS
AND SPECTRUM CATV**

NOTE:

- 1. ALL EXISTING OVERHEAD POWER ROUTING/CONNECTIVITY PROVIDED BY DUKE ENERGY AND GOOGLE EARTH. ALL EXISTING DUKE ENERGY POWER IN CONFLICT WILL BE WRECKED OUT
- 2. ALL EXISTING UNDERGROUND TELECOMMUNICATIONS AND POWER IN CONFLICT WITH THE PROJECT WILL BE ABANDONED IN PLACE

UTILITY OWNERS ON THIS SHEET

DUKE POWER - POWER (D)
WINDSTREAM - TELECOMMUNICATIONS
BRIGHTSPEED - TELECOMMUNICATIONS
SPECTRUM - CATV

RK&K
P: (919) 878-9560
8601 Six Forks Road, Forum 1, Suite 700
Raleigh, North Carolina 27615-3960
NC License No. F-0112
Engineers | Construction Managers | Planners | Scientists
www.rk.com
Responsive People | Creative Solutions

6/12/2024
C:\cloud\Projects\2016\16215_UO1_SAY\A01_L-R-2307B\Utilities\Engineering\UB0\RDY-5_UO03_psh.dgn
8/17/99

UTILITIES BY OTHERS

ALL PROPOSED UTILITY WORK SHOWN ON THIS SHEET WILL BE DONE BY OTHERS. NO PAYMENT WILL BE MADE TO THE CONTRACTOR FOR PROPOSED UTILITY WORK SHOWN ON THIS SHEET.

TGS ENGINEERS
 706 HILLSBOROUGH ST. SUITE 200
 RALEIGH, NC 27603
 PH (919) 773-8887
 CORP. LICENSE NO.: C-0275

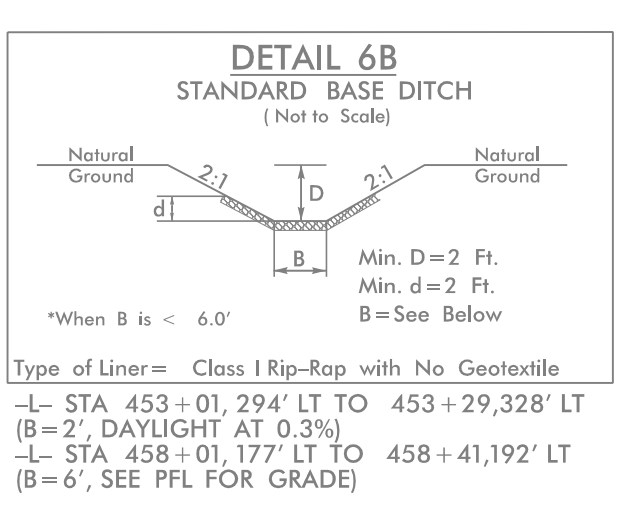
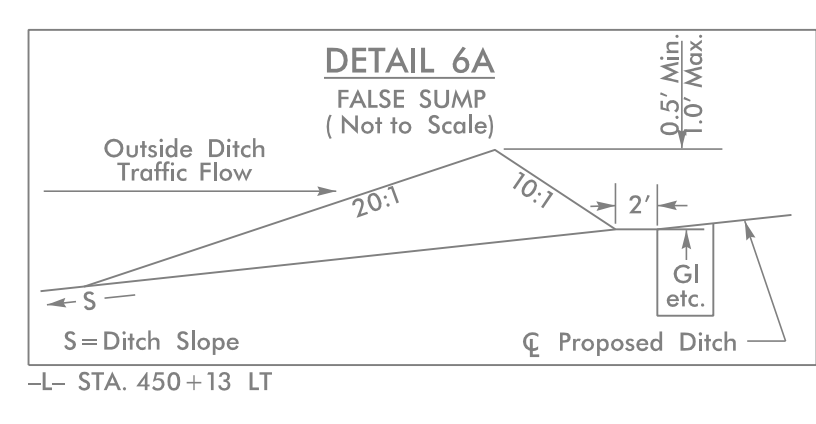

NEW AERIAL DUKE ENERGY POWER, WINDSTREAM COMMUNICATIONS AND SPECTRUM CATV

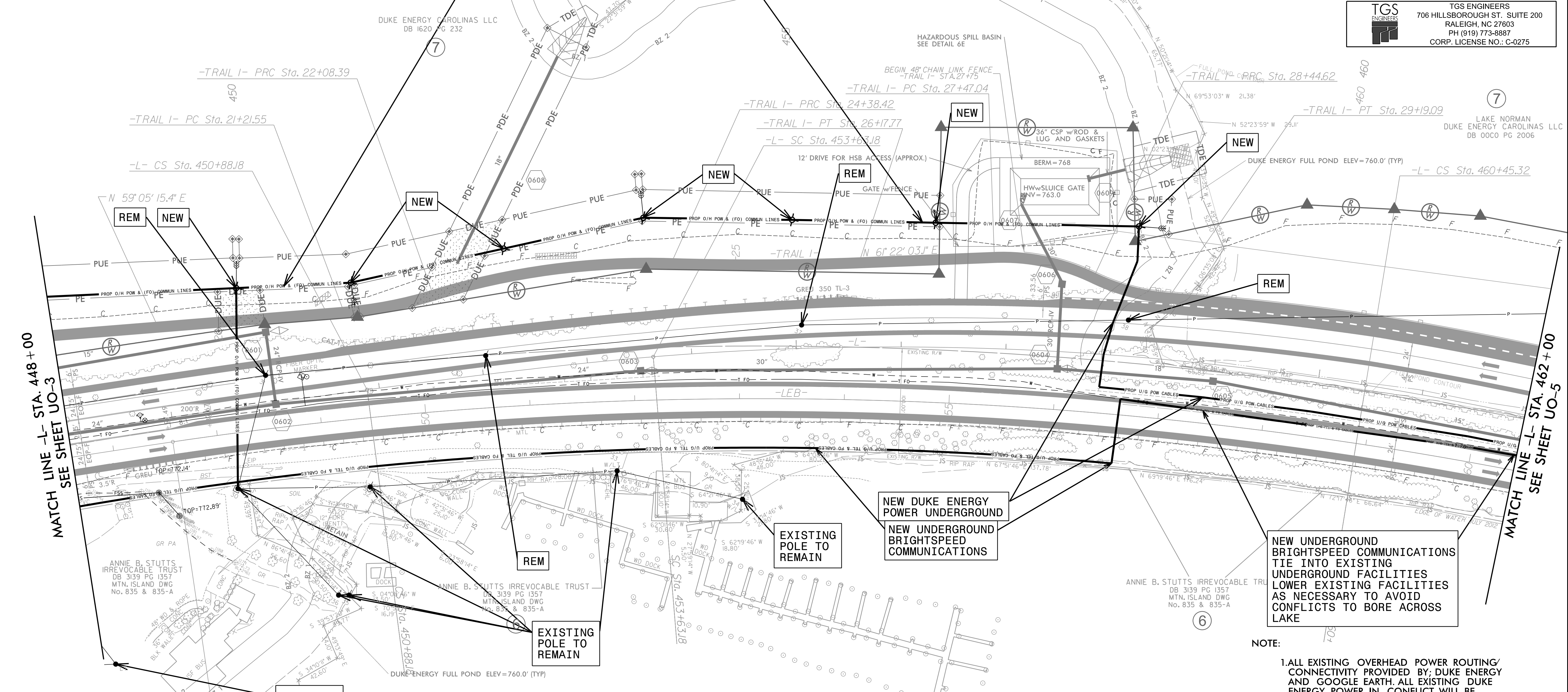

MATCH LINE -L- STA. 448+00 SEE SHEET UO-3

MATCH LINE -L- STA. 462+00 SEE SHEET UO-5

- NOTE:
1. ALL EXISTING OVERHEAD POWER ROUTING/CONNECTIVITY PROVIDED BY DUKE ENERGY AND GOOGLE EARTH. ALL EXISTING DUKE ENERGY POWER IN CONFLICT WILL BE WRECKED OUT
 2. ALL EXISTING UNDERGROUND TELECOMMUNICATIONS AND POWER IN CONFLICT WITH THE PROJECT WILL BE ABANDONED IN PLACE

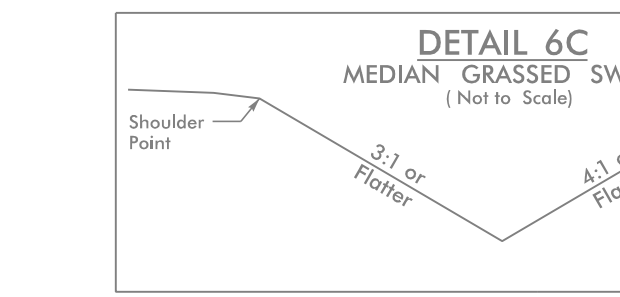

DETAIL 6D FALSE SUMP (Not to Scale)

Ditch Grade	L	Ditch Grade	L
0.0% To 2.0%	20'	Over 4.0% To 6.0%	40'
Over 2.0% To 4.0%	30'	Over 6.0%	50'

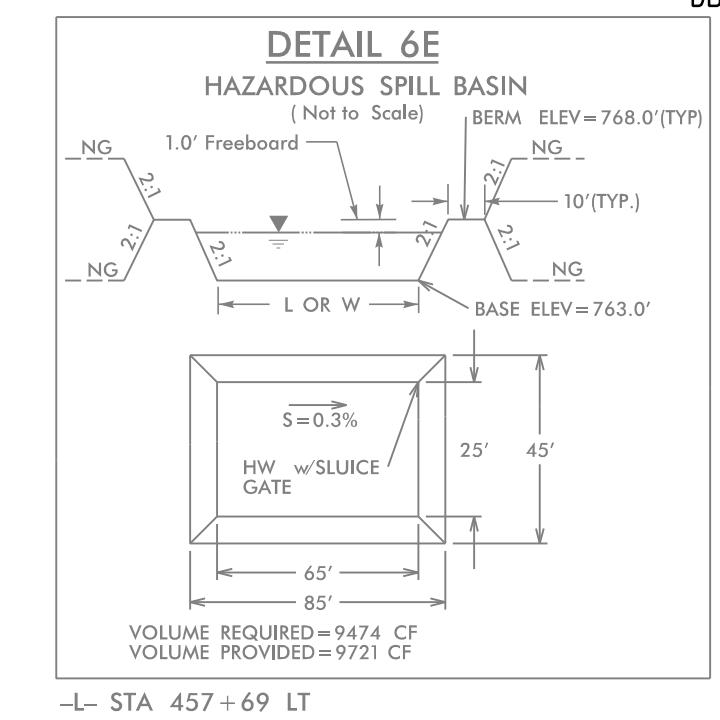

LAKE NORMAN
 DUKE ENERGY CAROLINAS LLC
 DB 0000 PG 2006

RK&K
 P: (919) 678-9560
 8801 Six Forks Road, Forum 1, Suite 700
 Raleigh, North Carolina 27615-3960
 NC License No. F-0112
 Engineers | Construction Managers | Planners | Scientists
 www.rk.com
 Responsive People | Creative Solutions

UTILITY OWNERS ON THIS SHEET

DUKE POWER - POWER (D)
 WINDSTREAM - TELECOMMUNICATIONS
 BRIGHTSPEED- TELECOMMUNICATIONS
 SPECTRUM - CATV

6/12/2024 C:\cloud\Projects\2016\162115\UO\1_SAY\A01_R-2307B\Utilities\Engineering\UB0\Pro\NR-2307B_ut_Rdy\06_U004_psh.dgn

UTILITIES BY OTHERS

ALL PROPOSED UTILITY WORK SHOWN ON THIS SHEET WILL BE DONE BY OTHERS. NO PAYMENT WILL BE MADE TO THE CONTRACTOR FOR PROPOSED UTILITY WORK SHOWN ON THIS SHEET.

	TGS ENGINEERS
	706 HILLSBOROUGH ST. SUITE 200
	RALEIGH, NC 27603
	PH (919) 773-8887
CORP. LICENSE NO.: C-0275	

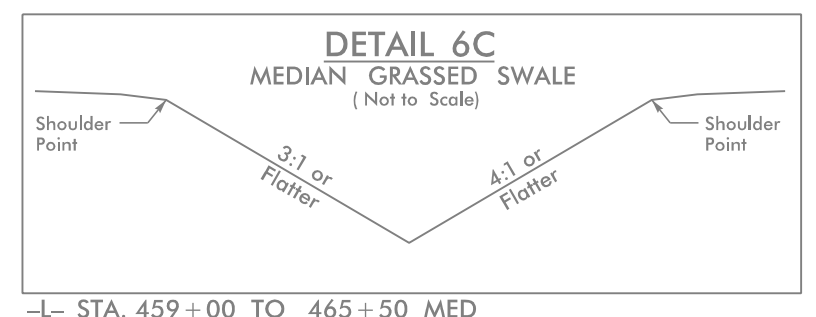

LAKE NORMAN
DUKE ENERGY CAROLINAS LLC
DB 0000 PG 2006

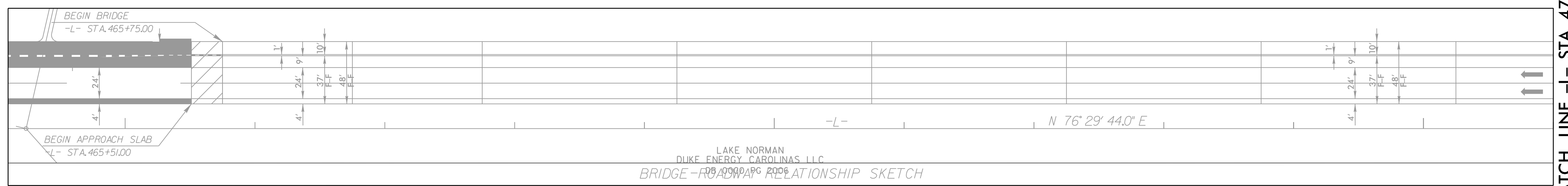
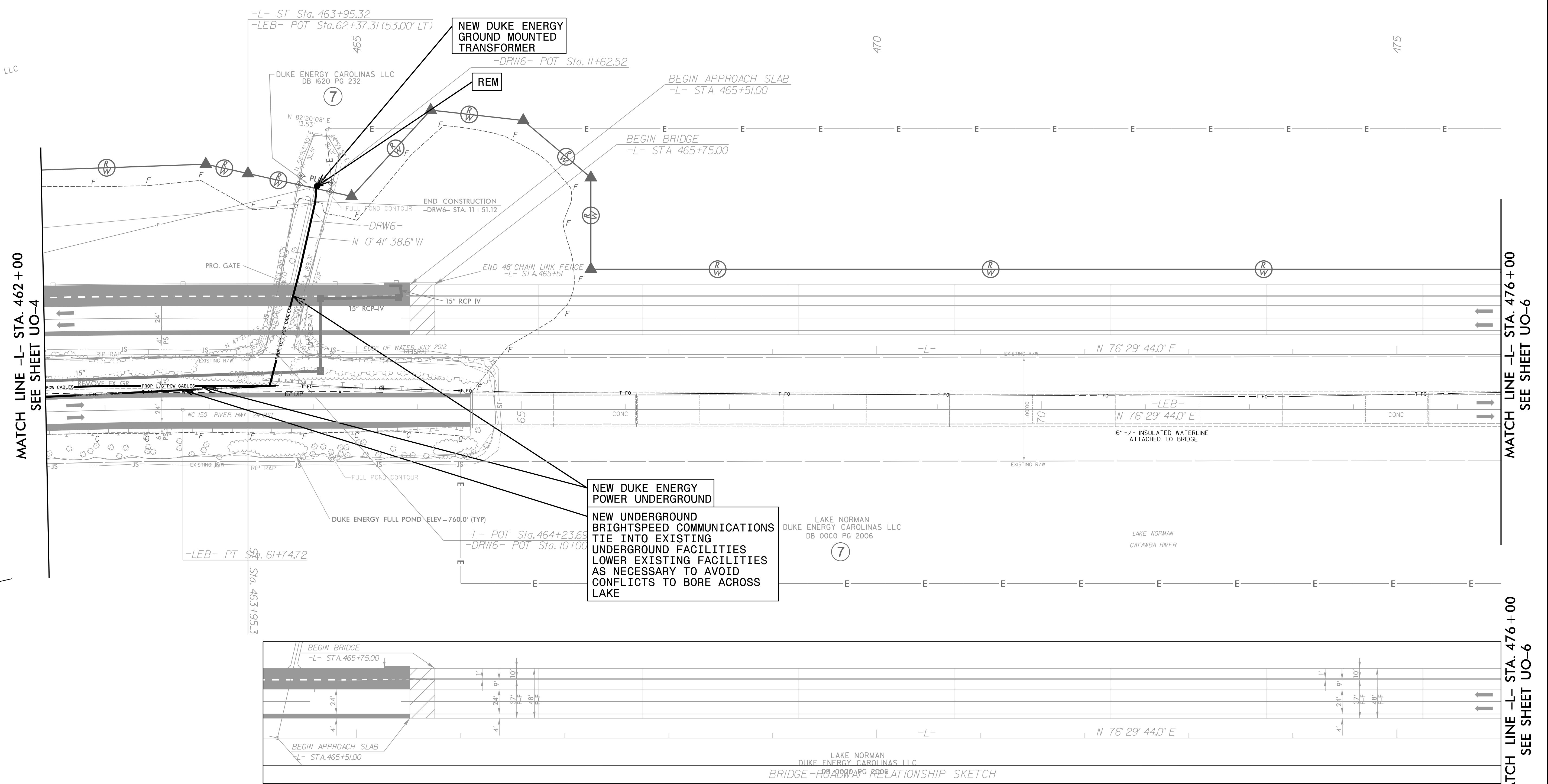
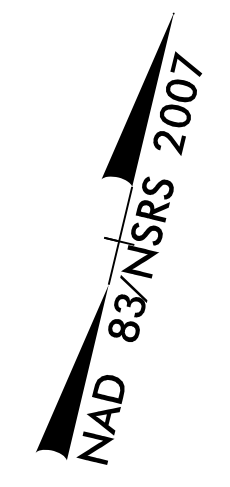

- NOTE:
1. ALL EXISTING OVERHEAD POWER ROUTING/CONNECTIVITY PROVIDED BY DUKE ENERGY AND GOOGLE EARTH. ALL EXISTING DUKE ENERGY POWER IN CONFLICT WILL BE WRECKED OUT
 2. ALL EXISTING UNDERGROUND TELECOMMUNICATIONS AND POWER IN CONFLICT WITH THE PROJECT WILL BE ABANDONED IN PLACE

UTILITY OWNERS ON THIS SHEET	
DUKE POWER - POWER (D)	
BRIGHTSPEED - TELECOMMUNICATIONS	

P: (919) 878-9560
8601 Six Forks Road, Forum 1, Suite 700
Raleigh, North Carolina 27615-3960
NC License No. F-0112
Engineers | Construction Managers | Planners | Scientists
www.rkk.com
Responsive People | Creative Solutions

8/17/09
 AS LLC
 6/12/2024
 S:\24\Projects\2016\16215_UO1_SAY\A01_R-2307B\Utilities\Engineering\UB0\Proj\N-2307B_ut.Rdy\07_UO05_psh.dgn
 def.dwg

MATCH LINE -L- STA. 476+00
 SEE SHEET UO-6
 MATCH LINE -L- STA. 476+00
 SEE SHEET UO-6

UTILITIES BY OTHERS

ALL PROPOSED UTILITY WORK SHOWN ON THIS SHEET WILL BE DONE BY OTHERS. NO PAYMENT WILL BE MADE TO THE CONTRACTOR FOR PROPOSED UTILITY WORK SHOWN ON THIS SHEET.

TGS ENGINEERS
 706 HILLSBOROUGH ST. SUITE 200
 RALEIGH, NC 27603
 PH (919) 773-8887
 CORP. LICENSE NO.: C-0275

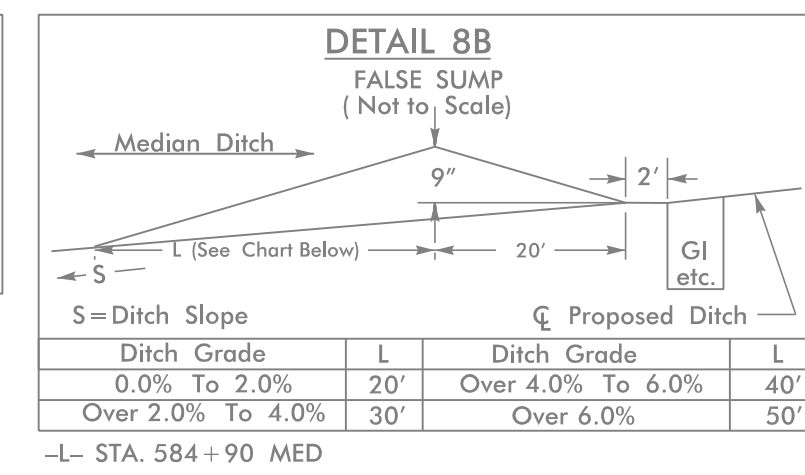
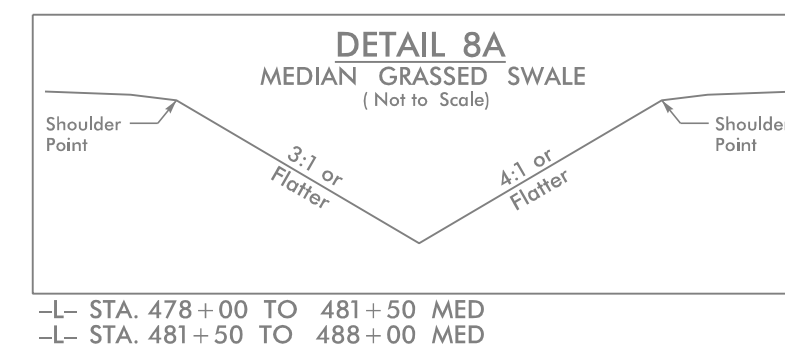
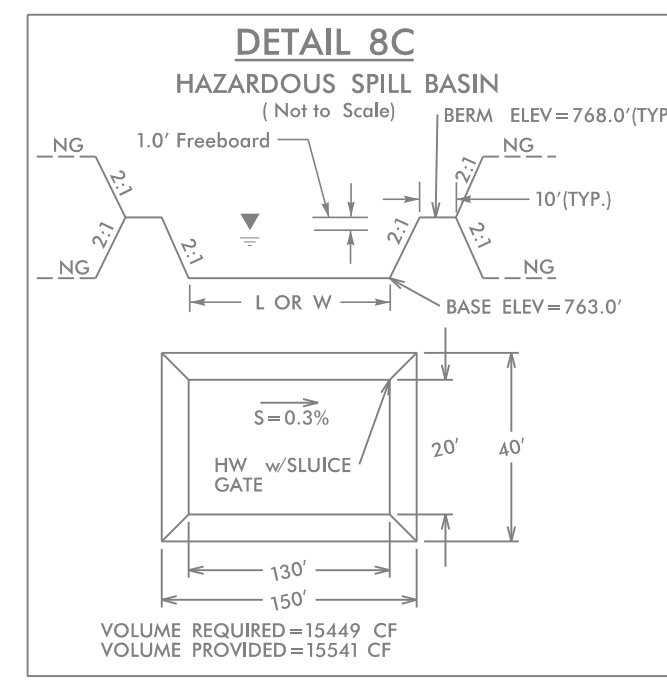

LAKE NORMAN
 DUKE ENERGY CAROLINAS LLC
 DB 00CO PG 2006
 7

MATCH LINE -L- STA. 476 + 00
 SEE SHEET UO-5

MATCH LINE -L- STA. 490 + 00
 SEE SHEET UO-7

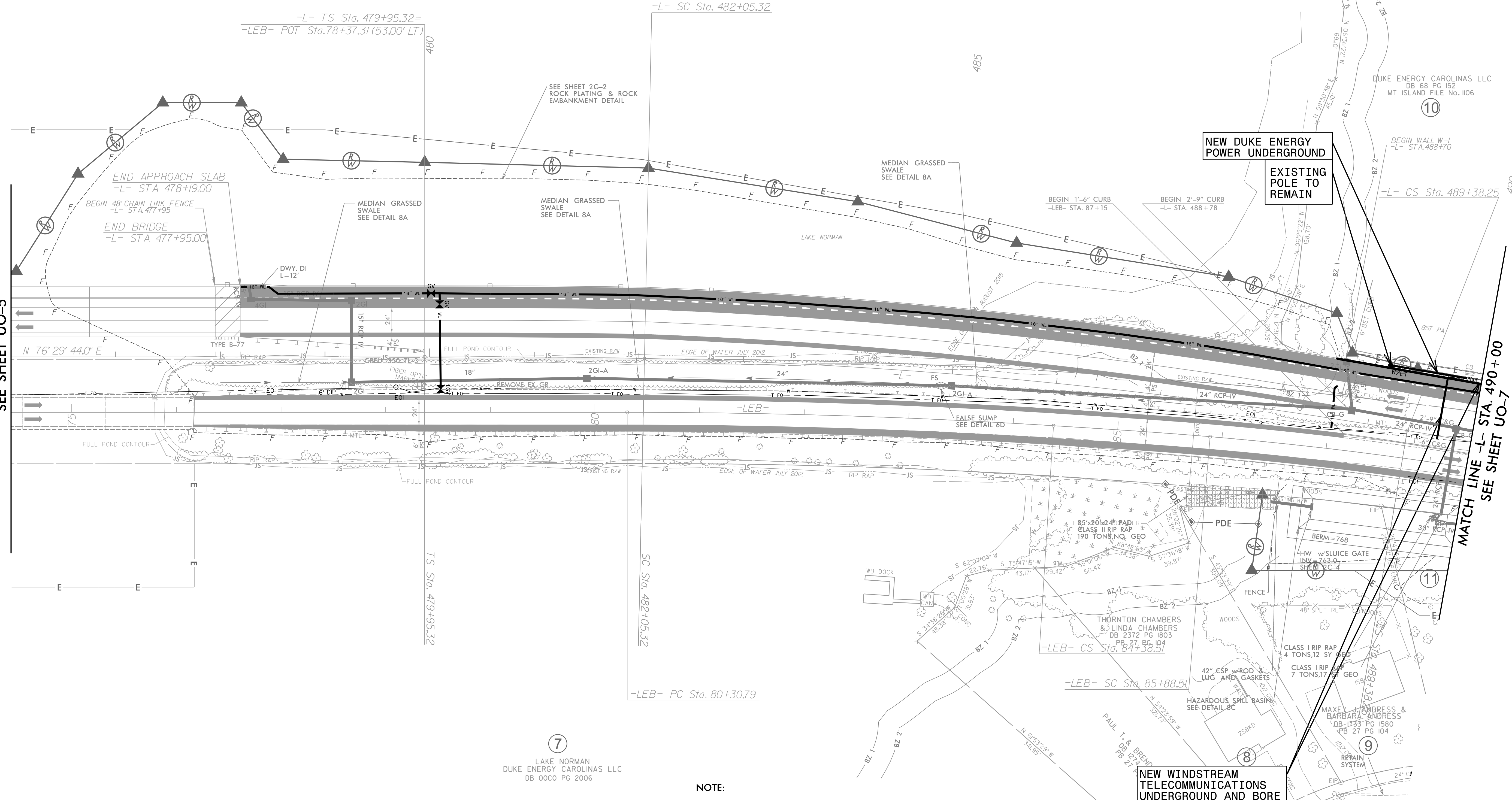

7
 LAKE NORMAN
 DUKE ENERGY CAROLINAS LLC
 DB 00CO PG 2006

NOTE:

1. ALL EXISTING OVERHEAD POWER ROUTING/ CONNECTIVITY PROVIDED BY; DUKE ENERGY AND GOOGLE EARTH. ALL EXISTING DUKE ENERGY POWER IN CONFLICT WILL BE WRECKED OUT
2. ALL EXISTING UNDERGROUND TELECOMMUNICATIONS AND POWER IN CONFLICT WITH THE PROJECT WILL BE ABANDONED IN PLACE

UTILITY OWNERS ON THIS SHEET

- DUKE ENERGY - POWER (D)
- BRIGHTSPEED - TELECOMMUNICATIONS
- CITY OF HICKORY - WATER

NEW WINDSTREAM TELECOMMUNICATIONS UNDERGROUND AND BORE

NEW DUKE ENERGY POWER UNDERGROUND
 EXISTING POLE TO REMAIN

RKK
 P: (919) 878-9560
 8601 Six Forks Road, Forum 1, Suite 700
 Raleigh, North Carolina 27615-3960
 NC License No. F-0112
 Engineers | Construction Managers | Planners | Scientists
 www.rkk.com
 Responsive People | Creative Solutions

8/21/2024
 R:\2024\Projects\2016\16215_UO1\SA\A01_R-2307B\Utilities\Engineering\UB0\Pro\N-2307B-ut_Rd\08_U006_psh.dgn
 8/17/24

UTILITIES BY OTHERS

ALL PROPOSED UTILITY WORK SHOWN ON THIS SHEET WILL BE DONE BY OTHERS. NO PAYMENT WILL BE MADE TO THE CONTRACTOR FOR PROPOSED UTILITY WORK SHOWN ON THIS SHEET.

TGS ENGINEERS
706 HILLSBOROUGH ST. SUITE 200
RALEIGH, NC 27603
PH (919) 773-8887
CORP. LICENSE NO.: C-0275

EXISTING DUKE ENERGY POWER 230 KV TRANSMISSION TOWER TO REMAIN

EXISTING POLE TO REMAIN

EXISTING DUKE ENERGY POWER 230 KV TRANSMISSION TOWER TO REMAIN

NEW AERIAL DUKE ENERGY POWER, WINDSTREAM COMMUNICATIONS, BRIGHTSPEED COMMUNICATIONS AND SPECTRUM CATV

NEW AERIAL DUKE ENERGY POWER, WINDSTREAM COMMUNICATIONS, BRIGHTSPEED COMMUNICATIONS AND SPECTRUM CATV

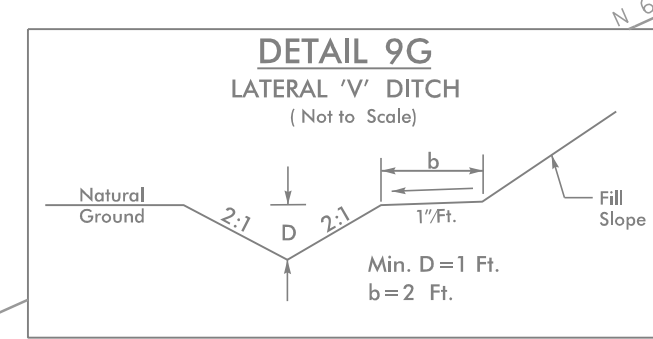
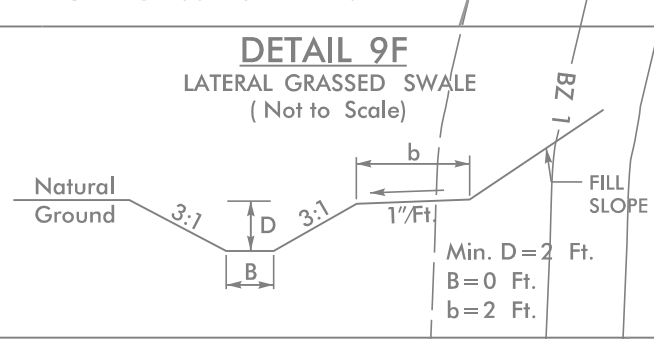
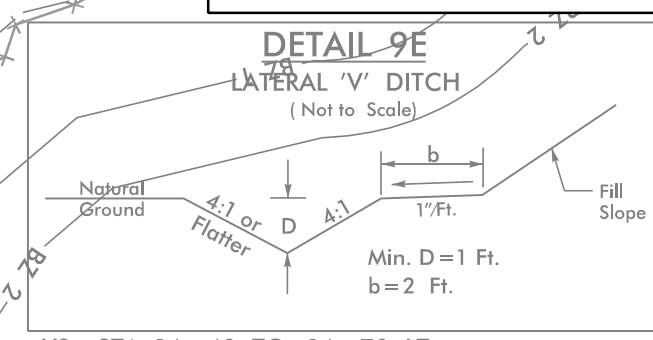
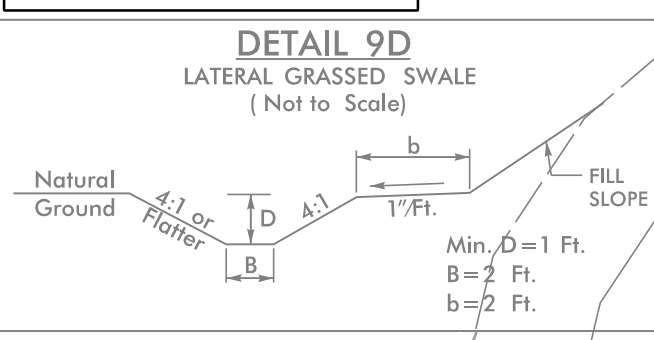
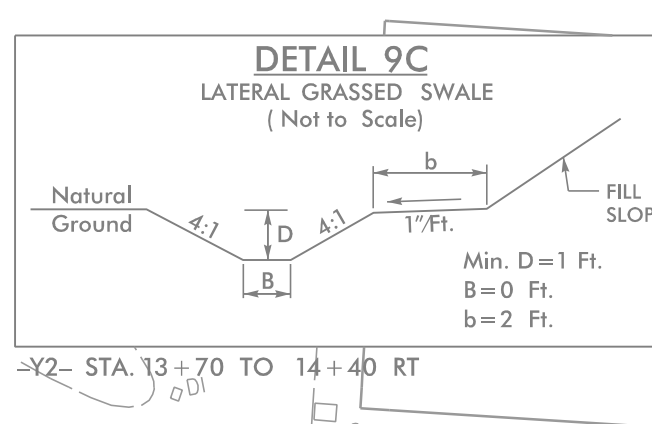
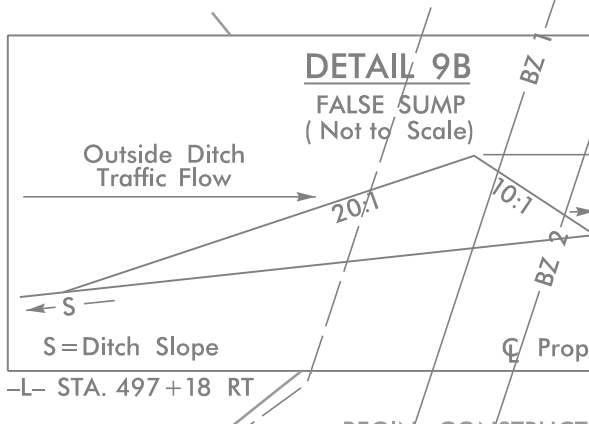
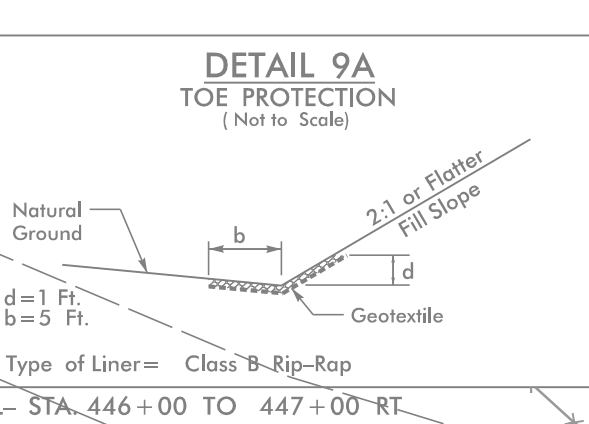

490 NAD 83/NSRS 2007

MATCH LINE -L- STA. 490+00
SEE SHEET UO-6

MATCH LINE -L- STA. 504+00
SEE SHEET UO-8

NOTE:

1. ALL EXISTING OVERHEAD POWER ROUTING/CONNECTIVITY PROVIDED BY DUKE ENERGY AND GOOGLE EARTH. ALL EXISTING DUKE ENERGY POWER IN CONFLICT WILL BE WRECKED OUT
2. ALL EXISTING UNDERGROUND TELECOMMUNICATIONS AND POWER IN CONFLICT WITH THE PROJECT WILL BE ABANDONED IN PLACE

UTILITY OWNERS ON THIS SHEET

- DUKE POWER - POWER (T)
- DUKE POWER - POWER (D)
- DOMINION ENERGY (PSNC) - NATURAL GAS
- WINDSTREAM - TELECOMMUNICATIONS
- BRIGHTSPEED - TELECOMMUNICATIONS
- TDS - COMMUNICATIONS
- MCIVERIZON - COMMUNICATIONS
- SPECTRUM - CATV
- CAROLINA WATER SYSTEMS - WATER
- AQUA - WATER SANITARY SEWER
- TOWN OF MOORESVILLE - WATER

RK&K
P: (919) 878-9560
8601 Six Forks Road, Forum 1, Suite 700
Raleigh, North Carolina 27615-3960
NC License No. F-0112
Engineers | Construction Managers | Planners | Scientists
www.rk.com
Responsive People | Creative Solutions

8/21/2024 C:\cadd\Projects\2016\162115\UO\UO-7\UO-7.dwg R-2307B\Utilities\Engineering\UB0\ProJ\NR-2307B\ut_rdy09_UO07_psh.dgn

UTILITIES BY OTHERS

ALL PROPOSED UTILITY WORK SHOWN ON THIS SHEET WILL BE DONE BY OTHERS. NO PAYMENT WILL BE MADE TO THE CONTRACTOR FOR PROPOSED UTILITY WORK SHOWN ON THIS SHEET.

	TGS ENGINEERS
	706 HILLSBOROUGH ST., SUITE 200
	RALEIGH, NC 27603
	PH (919) 773-8887 CORP. LICENSE NO.: C-0275

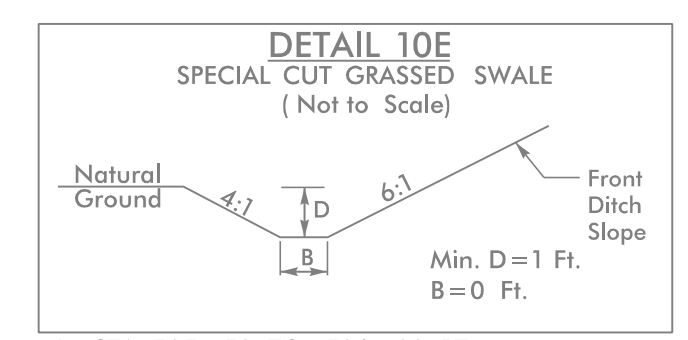
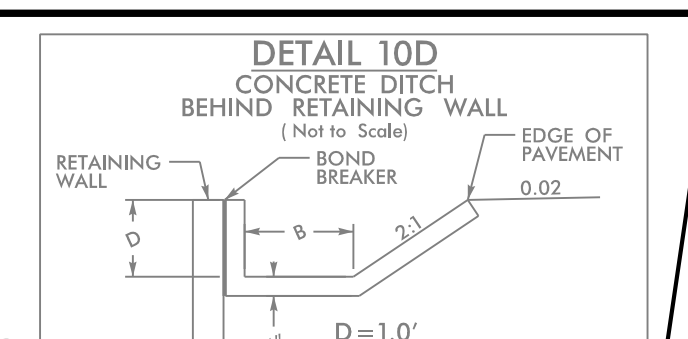
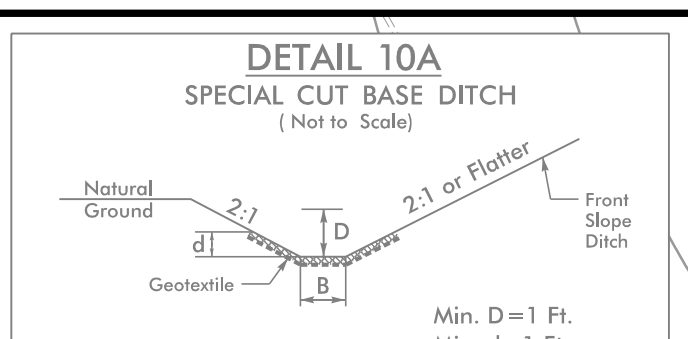
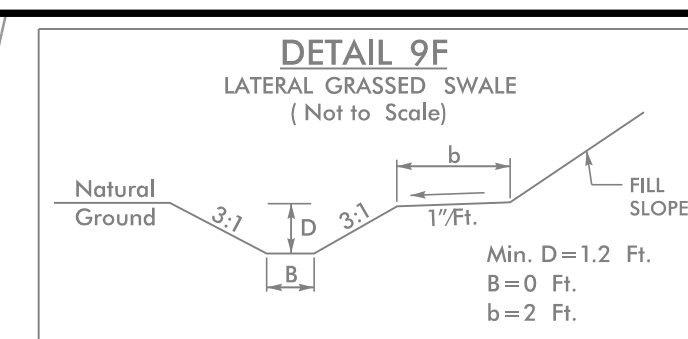

EXISTING DUKE ENERGY POWER 230 KV TRANSMISSION TOWER TO REMAIN

EXISTING POLE TO REMAIN

NEW WINDSTREAM TELECOMMUNICATIONS BORE

NEW DOMINION ENERGY 2" POLYETHYLENE LINE

NEW DUKE ENERGY POWER UNDERGROUND

MATCH LINE -L- STA. 504+00
SEE SHEET UO-7

MATCH LINE -L- STA. 518+00
SEE SHEET UO-9

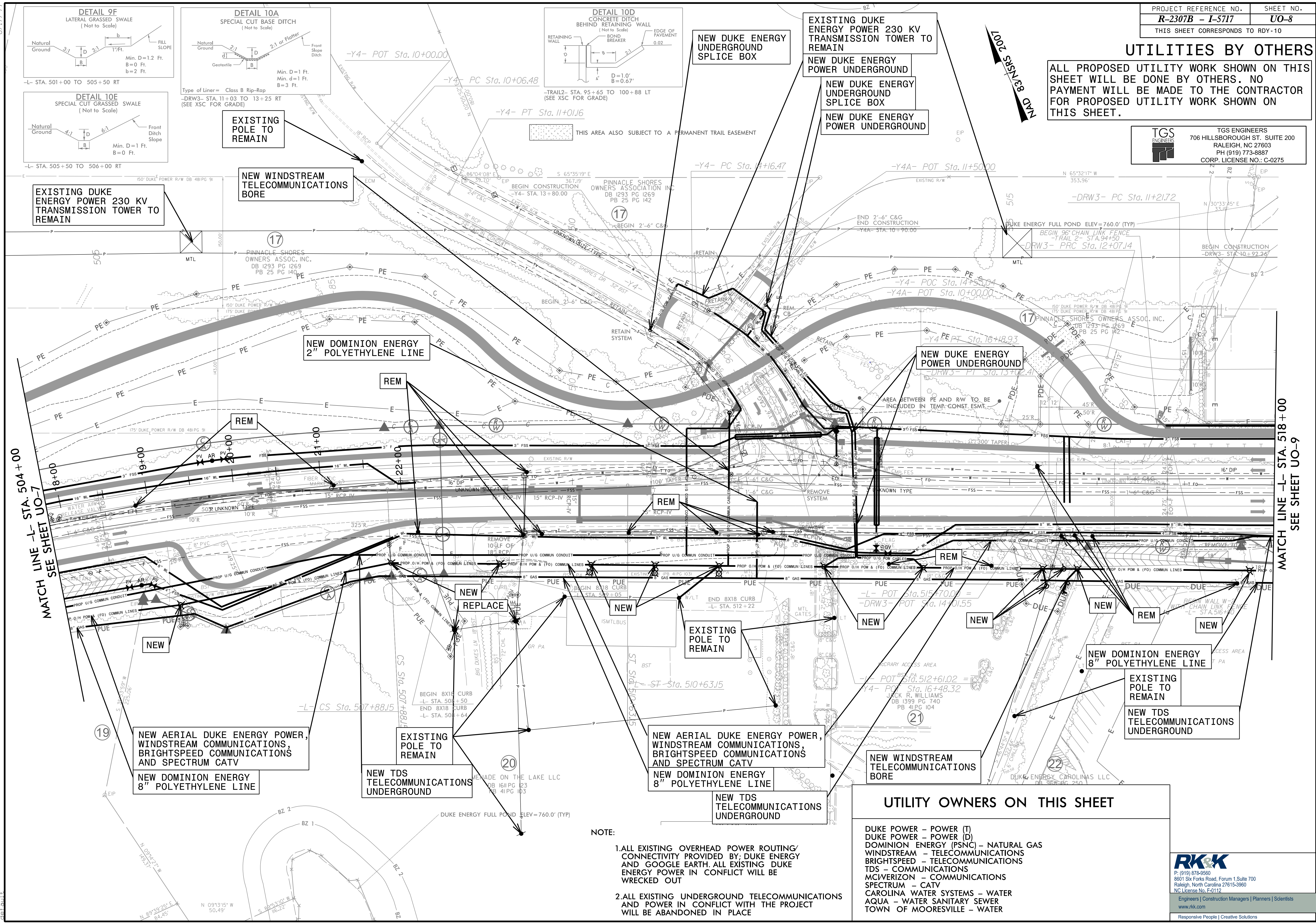

NEW AERIAL DUKE ENERGY POWER, WINDSTREAM COMMUNICATIONS, BRIGHTSPEED COMMUNICATIONS AND SPECTRUM CATV
NEW DOMINION ENERGY 8" POLYETHYLENE LINE

EXISTING POLE TO REMAIN
NEW TDS TELECOMMUNICATIONS UNDERGROUND

NEW AERIAL DUKE ENERGY POWER, WINDSTREAM COMMUNICATIONS, BRIGHTSPEED COMMUNICATIONS AND SPECTRUM CATV
NEW DOMINION ENERGY 8" POLYETHYLENE LINE
NEW TDS TELECOMMUNICATIONS UNDERGROUND

NEW WINDSTREAM TELECOMMUNICATIONS BORE

NEW DOMINION ENERGY 8" POLYETHYLENE LINE
EXISTING POLE TO REMAIN
NEW TDS TELECOMMUNICATIONS UNDERGROUND

UTILITY OWNERS ON THIS SHEET

- DUKE POWER - POWER (T)
- DUKE POWER - POWER (D)
- DOMINION ENERGY (PSNC) - NATURAL GAS
- WINDSTREAM - TELECOMMUNICATIONS
- BRIGHTSPEED - TELECOMMUNICATIONS
- TDS - COMMUNICATIONS
- MCIVERIZON - COMMUNICATIONS
- SPECTRUM - CATV
- CAROLINA WATER SYSTEMS - WATER
- AQUA - WATER SANITARY SEWER
- TOWN OF MOORESVILLE - WATER

NOTE:

1. ALL EXISTING OVERHEAD POWER ROUTING/CONNECTIVITY PROVIDED BY: DUKE ENERGY AND GOOGLE EARTH. ALL EXISTING DUKE ENERGY POWER IN CONFLICT WILL BE WRECKED OUT
2. ALL EXISTING UNDERGROUND TELECOMMUNICATIONS AND POWER IN CONFLICT WITH THE PROJECT WILL BE ABANDONED IN PLACE

P: (919) 878-9560
 8601 Six Forks Road, Forum 1, Suite 700
 Raleigh, North Carolina 27615-3960
 NC License No. F-0112
 Engineers | Construction Managers | Planners | Scientists
 www.rkk.com
 Responsive People | Creative Solutions

8/17/2024
 R:\2024\Projects\2016\16215\UOL\SAY\A01_R-2307B\Utilities\Engineering\UB0\Pro\N-2307B\ut_Rd\10_UO08_psh.dgn
 8/21/2024
 R:\2024\Projects\2016\16215\UOL\SAY\A01_R-2307B\Utilities\Engineering\UB0\Pro\N-2307B\ut_Rd\10_UO08_psh.dgn

NOTE:

1. ALL EXISTING OVERHEAD POWER ROUTING/CONNECTIVITY PROVIDED BY DUKE ENERGY AND GOOGLE EARTH. ALL EXISTING DUKE ENERGY POWER IN CONFLICT WILL BE WRECKED OUT
2. ALL EXISTING UNDERGROUND TELECOMMUNICATIONS AND POWER IN CONFLICT WITH THE PROJECT WILL BE ABANDONED IN PLACE

PROJECT REFERENCE NO. R-2307B - I-5717	SHEET NO. UO-9
THIS SHEET CORRESPONDS TO RDY-11	

UTILITIES BY OTHERS

ALL PROPOSED UTILITY WORK SHOWN ON THIS SHEET WILL BE DONE BY OTHERS. NO PAYMENT WILL BE MADE TO THE CONTRACTOR FOR PROPOSED UTILITY WORK SHOWN ON THIS SHEET.

TGS ENGINEERS
706 HILLSBOROUGH ST., SUITE 200
RALEIGH, NC 27603
PH (919) 773-8887
CORP. LICENSE NO.: C-0275

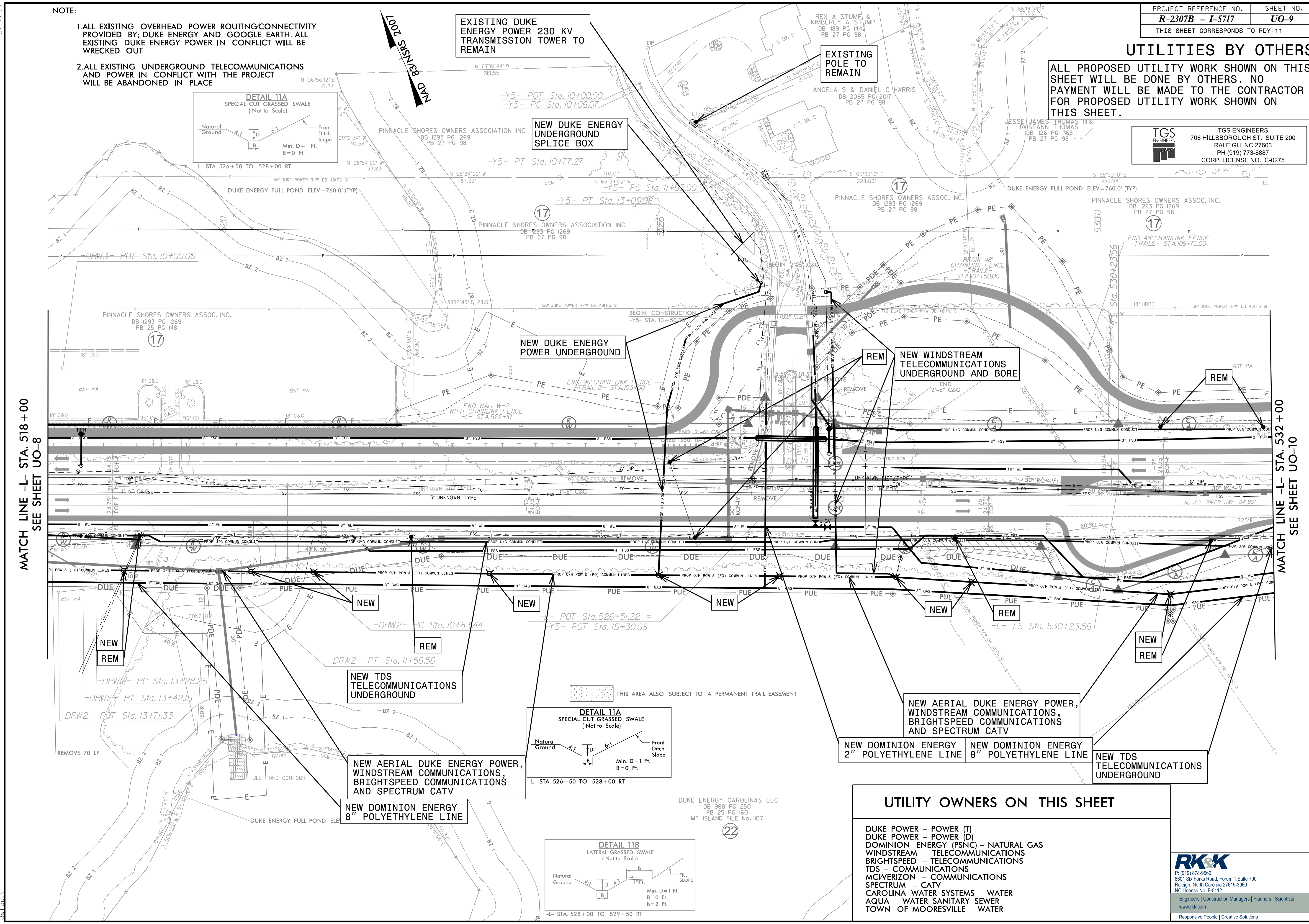

MATCH LINE -L- STA. 518 + 00
SEE SHEET UO-8

MATCH LINE -L- STA. 532 + 00
SEE SHEET UO-10

UTILITY OWNERS ON THIS SHEET	
DUKE POWER - POWER (T)	DUKE POWER - POWER (D)
DOMINION ENERGY (PSNC) - NATURAL GAS	WINDSTREAM - TELECOMMUNICATIONS
BRIGHTSPEED - TELECOMMUNICATIONS	TDs - COMMUNICATIONS
MCVERIZON - COMMUNICATIONS	SPECTRUM - CATV
CAROLINA WATER SYSTEMS - WATER	AQUA - WATER SANITARY SEWER
TOWN OF MOORESVILLE - WATER	

RK&K
P: (919) 878-9560
8601 Six Forks Road, Forum 1, Suite 700
Raleigh, North Carolina 27615-3960
NC License No. F-0112
Engineers | Construction Managers | Planners | Scientists
www.rkk.com
Responsive People | Creative Solutions

8/17/2024
C:\Users\jkk\OneDrive\Documents\Projects\2016\16215_UO\16215_UO\Utilities\Engineering\UB0\NR-2307B_UO-9_psh.dgn

UTILITIES BY OTHERS

ALL PROPOSED UTILITY WORK SHOWN ON THIS SHEET WILL BE DONE BY OTHERS. NO PAYMENT WILL BE MADE TO THE CONTRACTOR FOR PROPOSED UTILITY WORK SHOWN ON THIS SHEET.

	TGS ENGINEERS
	706 HILLSBOROUGH ST., SUITE 200
	RALEIGH, NC 27603
	PH (919) 773-8887 CORP. LICENSE NO.: C-0275

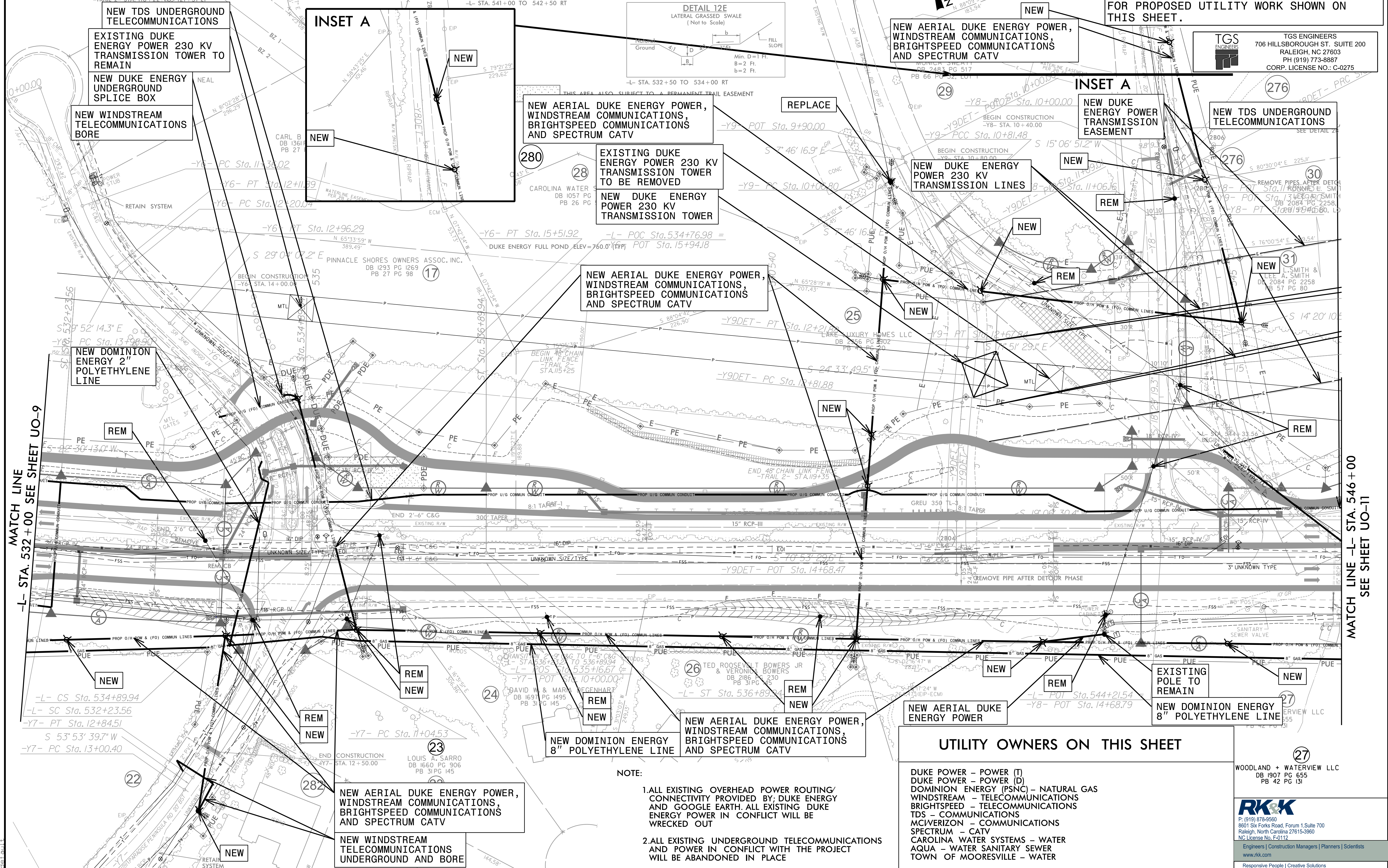
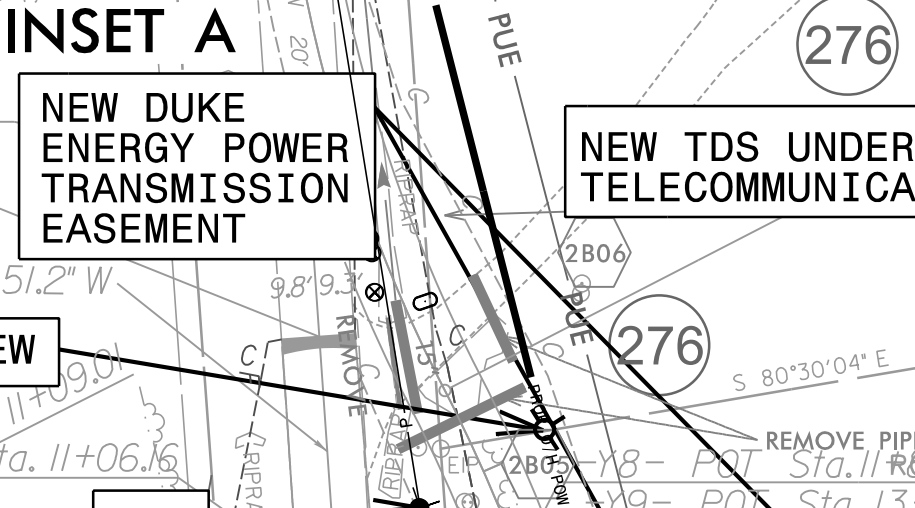
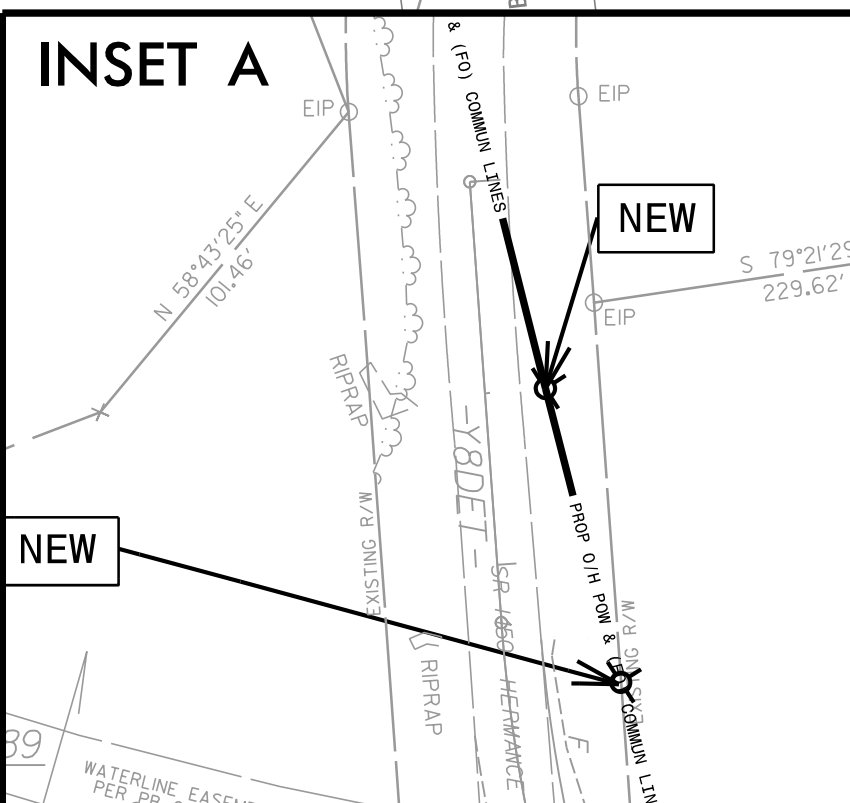
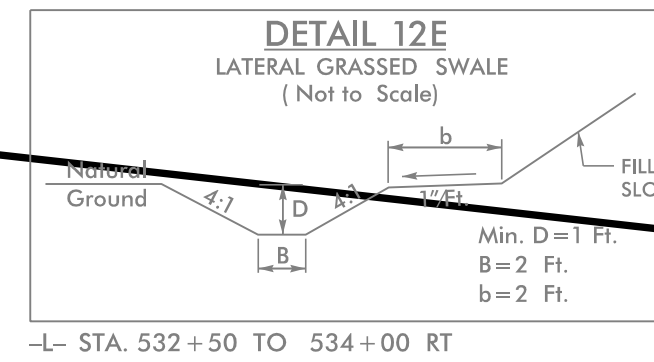
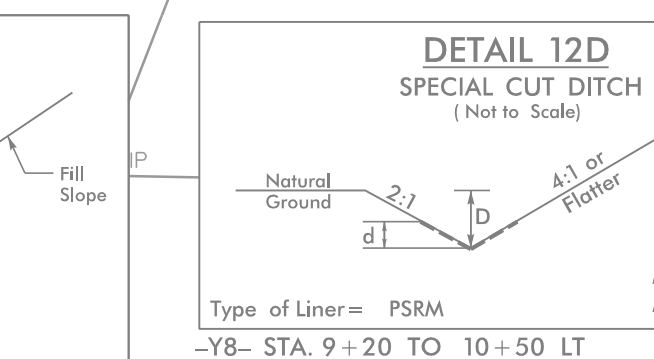
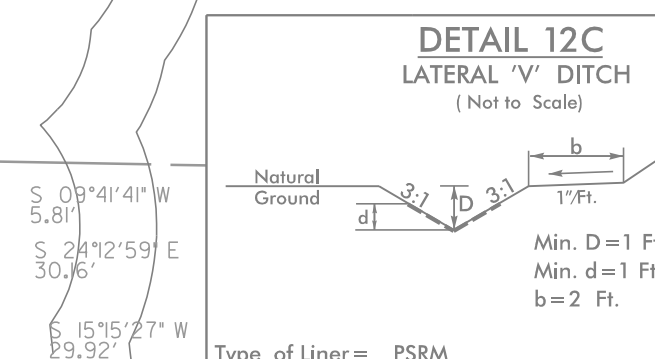
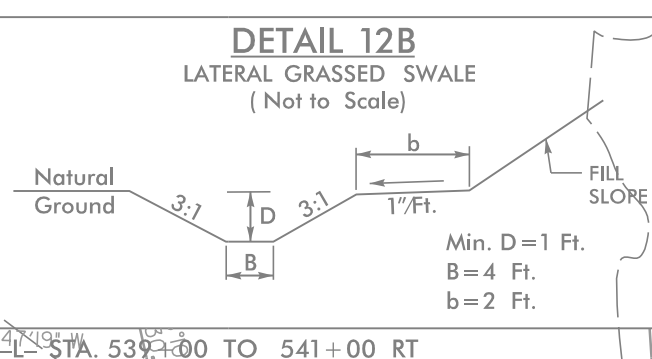
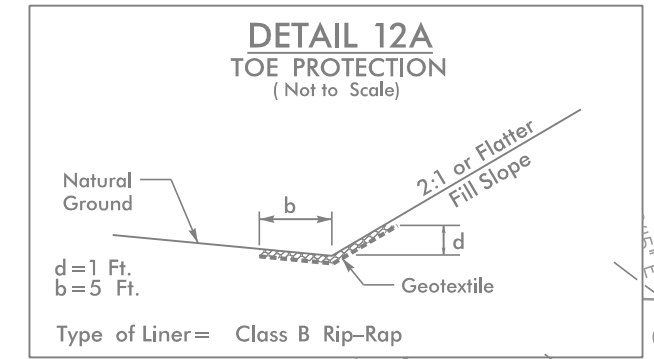

NEW TDS UNDERGROUND TELECOMMUNICATIONS

EXISTING DUKE ENERGY POWER 230 KV TRANSMISSION TOWER TO REMAIN

NEW DUKE ENERGY UNDERGROUND SPLICE BOX

NEW WINDSTREAM TELECOMMUNICATIONS BORE

NEW AERIAL DUKE ENERGY POWER, WINDSTREAM COMMUNICATIONS, BRIGHTSPEED COMMUNICATIONS AND SPECTRUM CATV

EXISTING DUKE ENERGY POWER 230 KV TRANSMISSION TOWER TO BE REMOVED

NEW DUKE ENERGY POWER 230 KV TRANSMISSION TOWER

NEW AERIAL DUKE ENERGY POWER, WINDSTREAM COMMUNICATIONS, BRIGHTSPEED COMMUNICATIONS AND SPECTRUM CATV

NEW AERIAL DUKE ENERGY POWER, WINDSTREAM COMMUNICATIONS, BRIGHTSPEED COMMUNICATIONS AND SPECTRUM CATV

NEW DUKE ENERGY POWER 230 KV TRANSMISSION LINES

NEW DOMINION ENERGY 2" POLYETHYLENE LINE

NEW DOMINION ENERGY 8" POLYETHYLENE LINE

NEW AERIAL DUKE ENERGY POWER, WINDSTREAM COMMUNICATIONS, BRIGHTSPEED COMMUNICATIONS AND SPECTRUM CATV

NEW AERIAL DUKE ENERGY POWER

EXISTING POLE TO REMAIN

NEW DOMINION ENERGY 8" POLYETHYLENE LINE

UTILITY OWNERS ON THIS SHEET

- DUKE POWER - POWER (T)
- DUKE POWER - POWER (D)
- DOMINION ENERGY (PSNC) NATURAL GAS
- WINDSTREAM - TELECOMMUNICATIONS
- BRIGHTSPEED - TELECOMMUNICATIONS
- TDS - COMMUNICATIONS
- MCIVERIZON - COMMUNICATIONS
- SPECTRUM - CATV
- CAROLINA WATER SYSTEMS - WATER
- AQUA - WATER SANITARY SEWER
- TOWN OF MOORESVILLE - WATER

WOODLAND + WATERVIEW LLC
DB 1907 PG 655
PB 42 PG 131

NOTE:

- ALL EXISTING OVERHEAD POWER ROUTING/CONNECTIVITY PROVIDED BY DUKE ENERGY AND GOOGLE EARTH. ALL EXISTING DUKE ENERGY POWER IN CONFLICT WILL BE WRECKED OUT
- ALL EXISTING UNDERGROUND TELECOMMUNICATIONS AND POWER IN CONFLICT WITH THE PROJECT WILL BE ABANDONED IN PLACE

8/21/2024 C:\cloud\Projects\2016\16215\UO1\SA\A01...R-2307B\Utilities\Engineering\UB0\Pro\NR-2307B_UO10.psh.dgn

MATCH LINE -L- STA. 546 + 00 SEE SHEET UO-11

MATCH LINE -L- STA. 532 + 00 SEE SHEET UO-9

UTILITIES BY OTHERS

ALL PROPOSED UTILITY WORK SHOWN ON THIS SHEET WILL BE DONE BY OTHERS. NO PAYMENT WILL BE MADE TO THE CONTRACTOR FOR PROPOSED UTILITY WORK SHOWN ON THIS SHEET.

TGS ENGINEERS
706 HILLSBOROUGH ST. SUITE 200
RALEIGH, NC 27603
PH (919) 773-8887
CORP. LICENSE NO.: C-0275

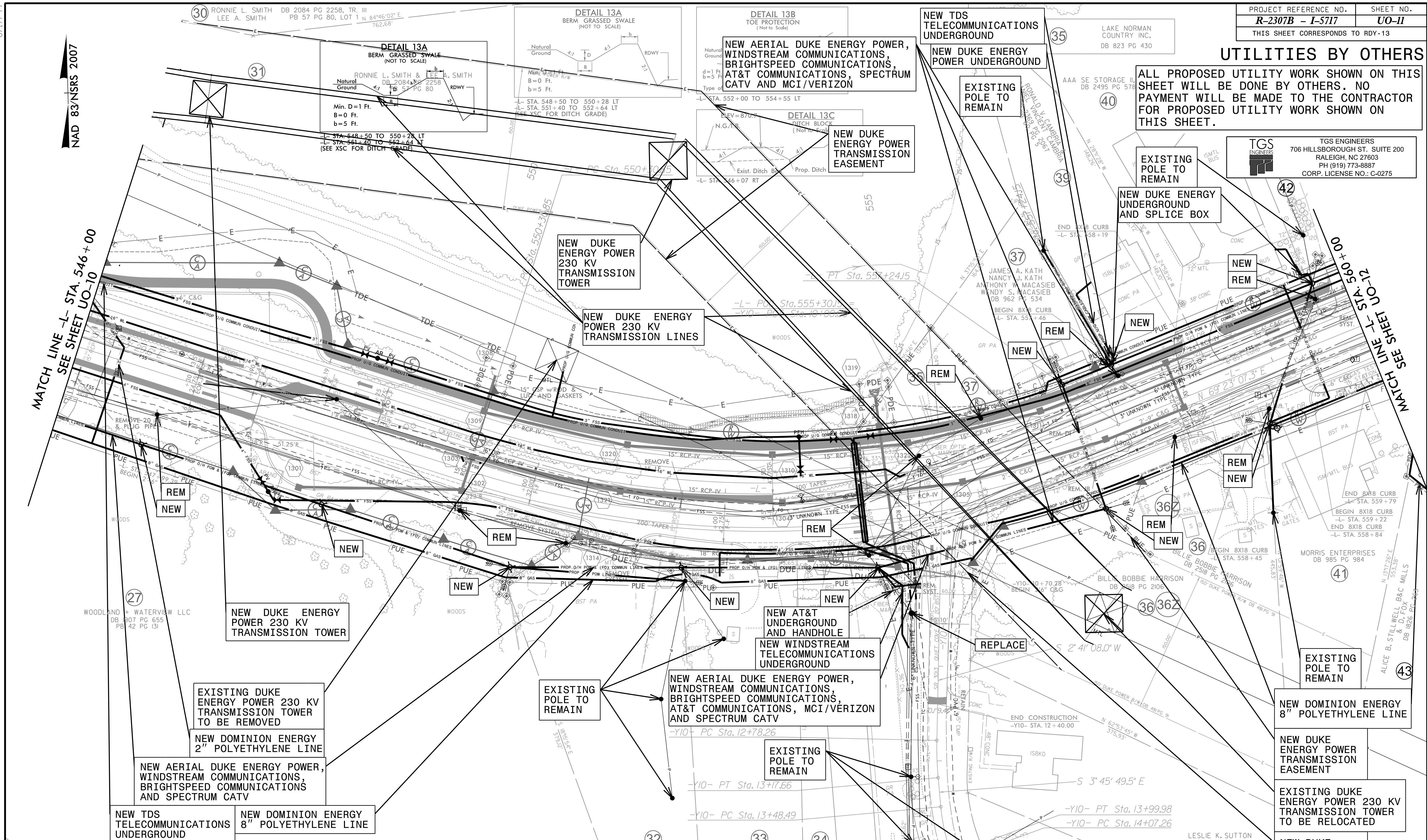

UTILITY OWNERS ON THIS SHEET

- DUKE POWER - POWER (T)
- DUKE POWER - POWER (D)
- DOMINION ENERGY (PSNC) - NATURAL GAS
- WINDSTREAM - TELECOMMUNICATIONS
- BRIGHTSPEED - TELECOMMUNICATIONS
- AT&T - TELECOMMUNICATIONS
- TDS - COMMUNICATIONS
- MCI/VERIZON - COMMUNICATIONS
- SPECTRUM - CATV
- AQUA - WATER SANITARY SEWER
- TOWN OF MOORESVILLE - WATER

- NOTE:
- ALL EXISTING OVERHEAD POWER ROUTING/CONNECTIVITY PROVIDED BY DUKE ENERGY AND GOOGLE EARTH. ALL EXISTING DUKE ENERGY POWER IN CONFLICT WILL BE WRECKED OUT
 - ALL EXISTING UNDERGROUND TELECOMMUNICATIONS AND POWER IN CONFLICT WITH THE PROJECT WILL BE ABANDONED IN PLACE

8/21/2024 C:\cloud\Projects\2016\162115_UO11_SAY\01_UO11_SAY\01_UO11_SAY\Projects\2016\162115_UO11_SAY\01_UO11_SAY\01_UO11_SAY.dgn

UTILITIES BY OTHERS

ALL PROPOSED UTILITY WORK SHOWN ON THIS SHEET WILL BE DONE BY OTHERS. NO PAYMENT WILL BE MADE TO THE CONTRACTOR FOR PROPOSED UTILITY WORK SHOWN ON THIS SHEET.

TGS ENGINEERS
706 HILLSBOROUGH ST. SUITE 200
RALEIGH, NC 27603
PH (919) 773-8887
CORP. LICENSE NO.: C-0275

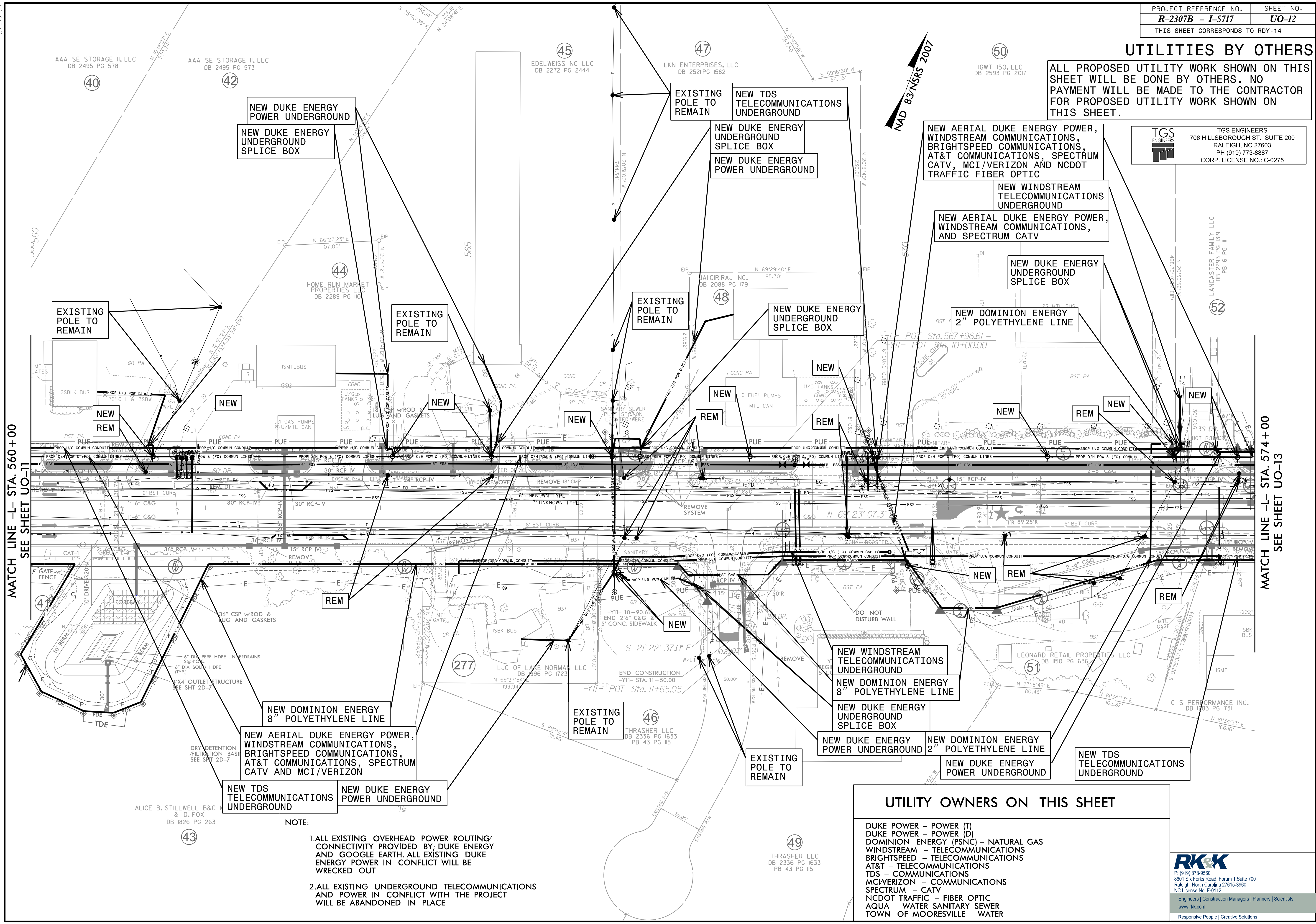

8/17/99
8/21/2024
2016.1621 U SA A01.R.2307 R.2307 U
E
U
R.2307
R.1.U.12
MATCH LINE -L- STA. 560+00
SEE SHEET UO-11

MATCH LINE -L- STA. 574+00
SEE SHEET UO-13

- NOTE:
1. ALL EXISTING OVERHEAD POWER ROUTING/CONNECTIVITY PROVIDED BY DUKE ENERGY AND GOOGLE EARTH. ALL EXISTING DUKE ENERGY POWER IN CONFLICT WILL BE WRECKED OUT
 2. ALL EXISTING UNDERGROUND TELECOMMUNICATIONS AND POWER IN CONFLICT WITH THE PROJECT WILL BE ABANDONED IN PLACE

UTILITY OWNERS ON THIS SHEET

DUKE POWER - POWER (T)
DUKE POWER - POWER (D)
DOMINION ENERGY (PSNC) - NATURAL GAS
WINDSTREAM - TELECOMMUNICATIONS
BRIGHTSPEED - TELECOMMUNICATIONS
AT&T - TELECOMMUNICATIONS
TDS - COMMUNICATIONS
MCI/VERIZON - COMMUNICATIONS
SPECTRUM - CATV
NCDOT TRAFFIC - FIBER OPTIC
AQUA - WATER SANITARY SEWER
TOWN OF MOORESVILLE - WATER



UTILITIES BY OTHERS

ALL PROPOSED UTILITY WORK SHOWN ON THIS SHEET WILL BE DONE BY OTHERS. NO PAYMENT WILL BE MADE TO THE CONTRACTOR FOR PROPOSED UTILITY WORK SHOWN ON THIS SHEET.

TGS ENGINEERS
 706 HILLSBOROUGH ST., SUITE 200
 RALEIGH, NC 27603
 PH (919) 773-8887
 CORP. LICENSE NO.: C-0275

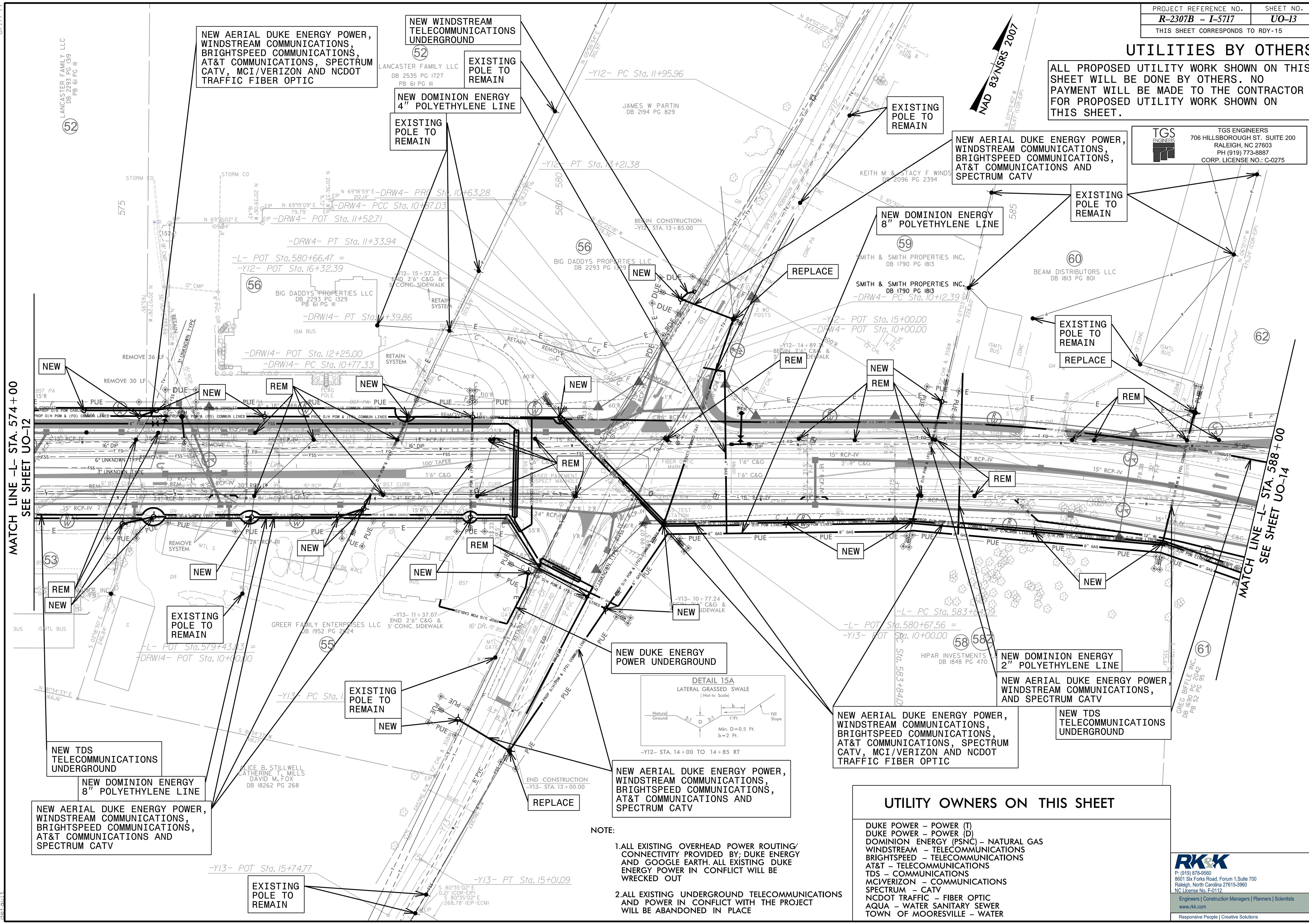

MATCH LINE -L- STA. 574+00
SEE SHEET UO-12

MATCH LINE -L- STA. 588+00
SEE SHEET UO-14

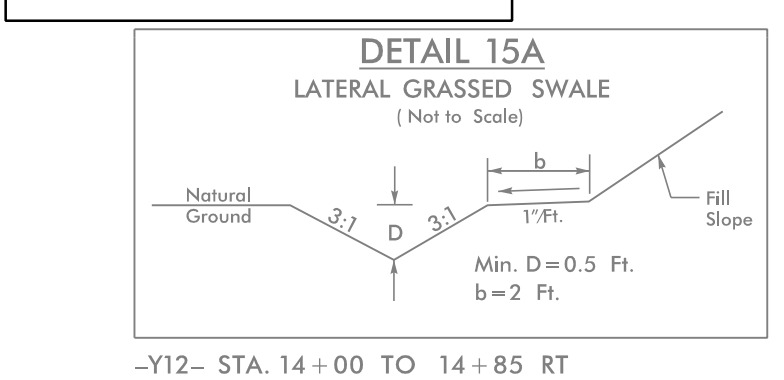

UTILITY OWNERS ON THIS SHEET

- DUKE POWER - POWER (T)
- DUKE POWER - POWER (D)
- DOMINION ENERGY (PSNC) - NATURAL GAS
- WINDSTREAM - TELECOMMUNICATIONS
- BRIGHTSPEED - TELECOMMUNICATIONS
- AT&T - TELECOMMUNICATIONS
- TDS - COMMUNICATIONS
- MCIVERIZON - COMMUNICATIONS
- SPECTRUM - CATV
- NC DOT TRAFFIC - FIBER OPTIC
- AQUA - WATER SANITARY SEWER
- TOWN OF MOORESVILLE - WATER

- NOTE:**
1. ALL EXISTING OVERHEAD POWER ROUTING/CONNECTIVITY PROVIDED BY; DUKE ENERGY AND GOOGLE EARTH. ALL EXISTING DUKE ENERGY POWER IN CONFLICT WILL BE WRECKED OUT
 2. ALL EXISTING UNDERGROUND TELECOMMUNICATIONS AND POWER IN CONFLICT WITH THE PROJECT WILL BE ABANDONED IN PLACE

RKK
 P: (919) 878-9560
 8601 Six Forks Road, Forum 1, Suite 700
 Raleigh, North Carolina 27615-3960
 NC License No. F-0112
 Engineers | Construction Managers | Planners | Scientists
 www.rkk.com
 Responsive People | Creative Solutions

8/17/2024
 R:\2307B\Projects\2016\16215_UO13\SA\A01_UO13\Utilities\Engineering\UB00\NR-2307B_UO13.psd.dgn
 8/17/2024
 R:\2307B\Projects\2016\16215_UO13\SA\A01_UO13\Utilities\Engineering\UB00\NR-2307B_UO13.psd.dgn

UTILITIES BY OTHERS

ALL PROPOSED UTILITY WORK SHOWN ON THIS SHEET WILL BE DONE BY OTHERS. NO PAYMENT WILL BE MADE TO THE CONTRACTOR FOR PROPOSED UTILITY WORK SHOWN ON THIS SHEET.

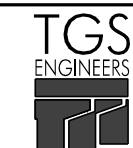
	TGS ENGINEERS
	706 HILLSBOROUGH ST., SUITE 200
	RALEIGH, NC 27603
	PH (919) 773-8887 CORP. LICENSE NO.: C-0275

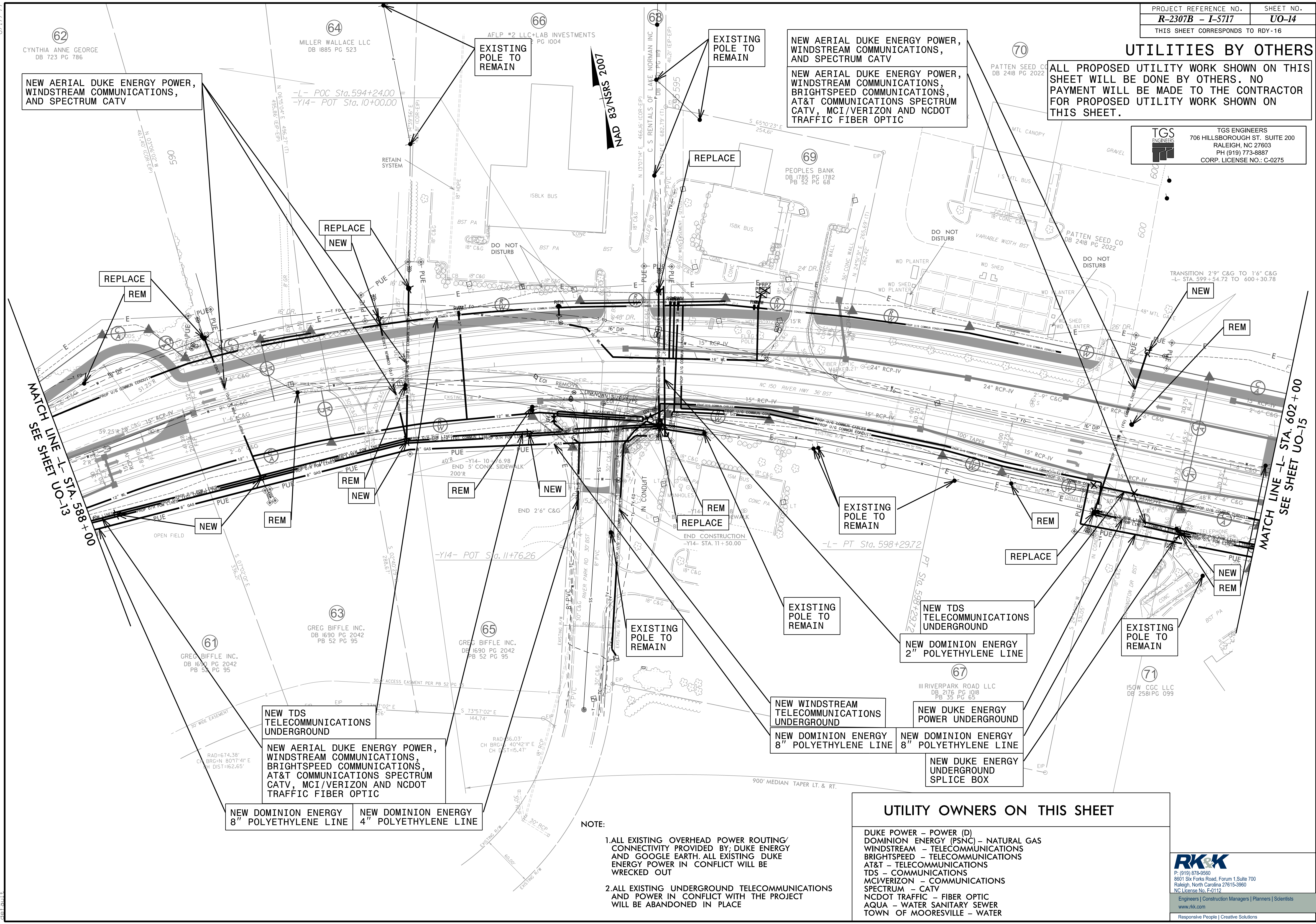

NEW AERIAL DUKE ENERGY POWER, WINDSTREAM COMMUNICATIONS, AND SPECTRUM CATV

EXISTING POLE TO REMAIN

EXISTING POLE TO REMAIN

NEW AERIAL DUKE ENERGY POWER, WINDSTREAM COMMUNICATIONS, BRIGHTSPEED COMMUNICATIONS, AT&T COMMUNICATIONS SPECTRUM CATV, MCI/VERIZON AND NCDOT TRAFFIC FIBER OPTIC

REPLACE NEW

REPLACE REM

REPLACE

NEW

REM

MATCH LINE -L- STA. 588+00
SEE SHEET UO-13

MATCH LINE -L- STA. 602+00
SEE SHEET UO-15

NEW TDS TELECOMMUNICATIONS UNDERGROUND
NEW AERIAL DUKE ENERGY POWER, WINDSTREAM COMMUNICATIONS, BRIGHTSPEED COMMUNICATIONS, AT&T COMMUNICATIONS SPECTRUM CATV, MCI/VERIZON AND NCDOT TRAFFIC FIBER OPTIC

NEW DOMINION ENERGY 8" POLYETHYLENE LINE
NEW DOMINION ENERGY 4" POLYETHYLENE LINE

EXISTING POLE TO REMAIN

EXISTING POLE TO REMAIN

NEW TDS TELECOMMUNICATIONS UNDERGROUND
NEW DOMINION ENERGY 2" POLYETHYLENE LINE

EXISTING POLE TO REMAIN

NEW WINDSTREAM TELECOMMUNICATIONS UNDERGROUND
NEW DOMINION ENERGY 8" POLYETHYLENE LINE

NEW DUKE ENERGY POWER UNDERGROUND
NEW DOMINION ENERGY 8" POLYETHYLENE LINE

NEW DUKE ENERGY UNDERGROUND SPLICE BOX

UTILITY OWNERS ON THIS SHEET

- DUKE POWER - POWER (D)
- DOMINION ENERGY (PSNC) - NATURAL GAS
- WINDSTREAM - TELECOMMUNICATIONS
- BRIGHTSPEED - TELECOMMUNICATIONS
- AT&T - TELECOMMUNICATIONS
- TDS - COMMUNICATIONS
- MCI/VERIZON - COMMUNICATIONS
- SPECTRUM - CATV
- NCDOT TRAFFIC - FIBER OPTIC
- AQUA - WATER SANITARY SEWER
- TOWN OF MOORESVILLE - WATER

NOTE:

1. ALL EXISTING OVERHEAD POWER ROUTING/CONNECTIVITY PROVIDED BY DUKE ENERGY AND GOOGLE EARTH. ALL EXISTING DUKE ENERGY POWER IN CONFLICT WILL BE WRECKED OUT
2. ALL EXISTING UNDERGROUND TELECOMMUNICATIONS AND POWER IN CONFLICT WITH THE PROJECT WILL BE ABANDONED IN PLACE



P: (919) 878-9560
8601 Six Forks Road, Forum 1, Suite 700
Raleigh, North Carolina 27615-3960
NC License No. F-0112
Engineers | Construction Managers | Planners | Scientists
www.rkk.com
Responsive People | Creative Solutions

8/17/2024
 R:\2307B\Projects\2016\16215_UO14\SA\A01_R-2307B\Utilities\Engineering\UB0\Proj\N-2307B-ut_Rdy16_UO14_psh.dgn
 8/17/2024

UTILITIES BY OTHERS

ALL PROPOSED UTILITY WORK SHOWN ON THIS SHEET WILL BE DONE BY OTHERS. NO PAYMENT WILL BE MADE TO THE CONTRACTOR FOR PROPOSED UTILITY WORK SHOWN ON THIS SHEET.

TGS ENGINEERS
 706 HILLSBOROUGH ST. SUITE 200
 RALEIGH, NC 27603
 PH (919) 773-8887
 CORP. LICENSE NO.: C-0275

8/17/2024
 R:\2307B\Projects\2016\162115_UO15\Drawings\Utilities\UB07_UO15_psh.dgn
 8/22/2024
 R:\2307B\Projects\2016\162115_UO15\Drawings\Utilities\UB07_UO15_psh.dgn

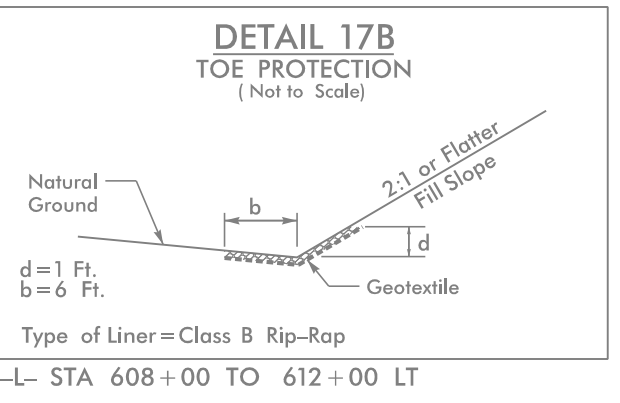
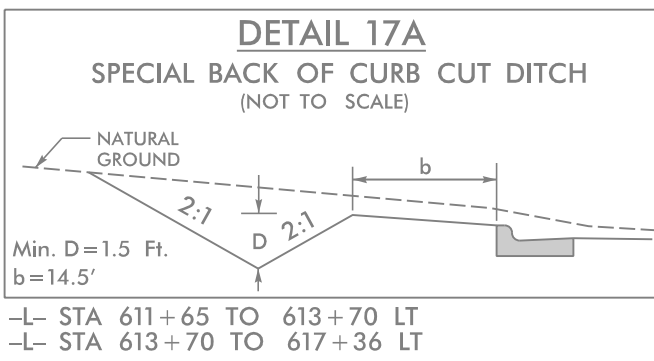
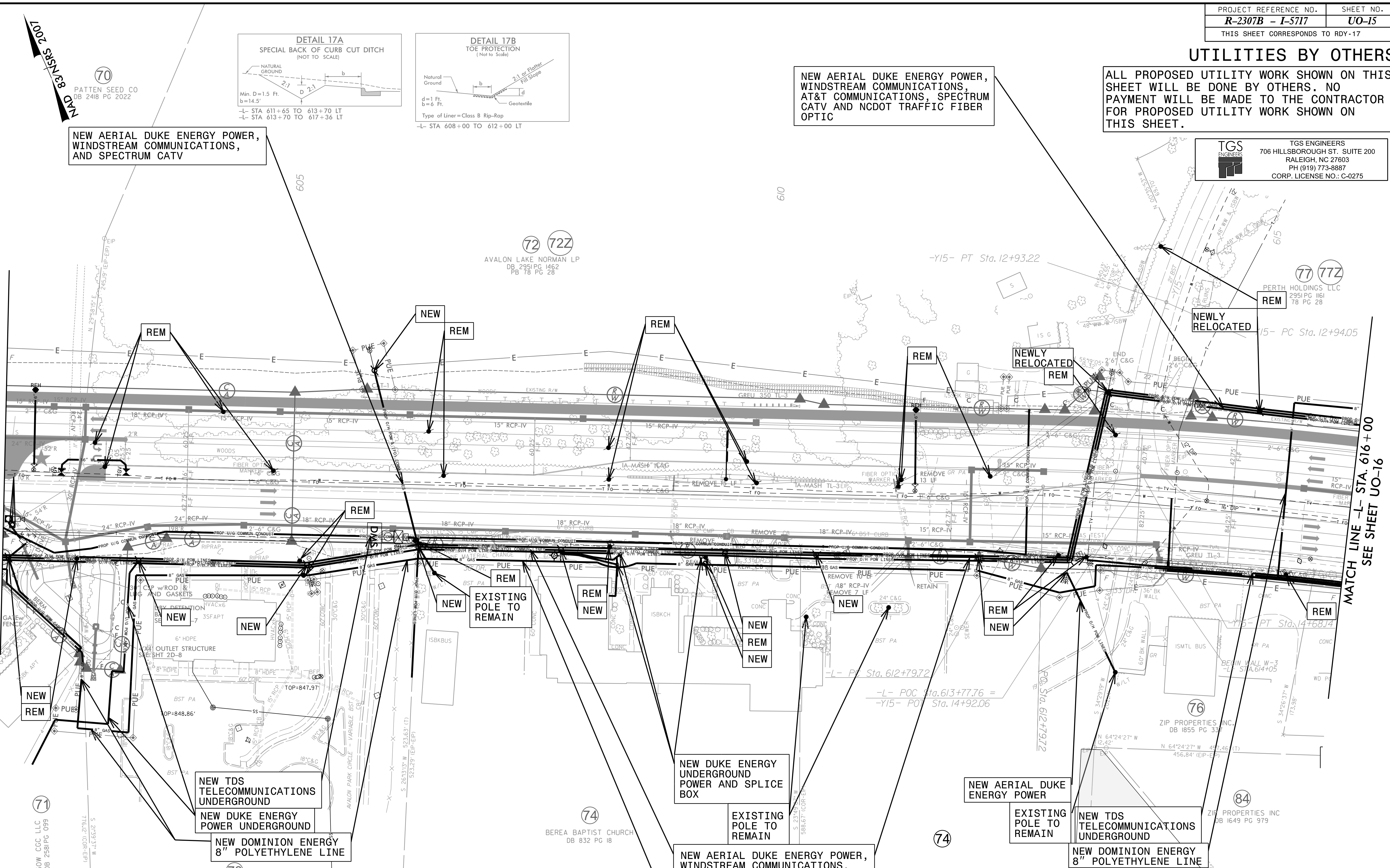

NEW AERIAL DUKE ENERGY POWER, WINDSTREAM COMMUNICATIONS, AND SPECTRUM CATV

NEW AERIAL DUKE ENERGY POWER, WINDSTREAM COMMUNICATIONS, AT&T COMMUNICATIONS, SPECTRUM CATV AND NCDOT TRAFFIC FIBER OPTIC

MATCH LINE -L- STA. 602+00
SEE SHEET UO-14

MATCH LINE -L- STA. 616+00
SEE SHEET UO-16

NEW TDS TELECOMMUNICATIONS UNDERGROUND
 NEW DUKE ENERGY POWER UNDERGROUND
 NEW DOMINION ENERGY 8" POLYETHYLENE LINE

NEW DUKE ENERGY UNDERGROUND POWER AND SPLICE BOX

NEW AERIAL DUKE ENERGY POWER, WINDSTREAM COMMUNICATIONS, BRIGHTSPEED COMMUNICATIONS, AT&T COMMUNICATIONS, SPECTRUM CATV MCI/VERIZON AND NCDOT TRAFFIC FIBER OPTIC
 NEW DOMINION ENERGY 8" POLYETHYLENE LINE

NEW AERIAL DUKE ENERGY POWER
 EXISTING POLE TO REMAIN

NEW TDS TELECOMMUNICATIONS UNDERGROUND
 NEW DOMINION ENERGY 8" POLYETHYLENE LINE

UTILITY OWNERS ON THIS SHEET

- DUKE POWER - POWER (D)
- DOMINION ENERGY (PSNC) - NATURAL GAS
- WINDSTREAM - TELECOMMUNICATIONS
- BRIGHTSPEED - TELECOMMUNICATIONS
- AT&T - TELECOMMUNICATIONS
- TDS - COMMUNICATIONS
- MCI/VERIZON - COMMUNICATIONS
- SPECTRUM - CATV
- NCDOT TRAFFIC - FIBER OPTIC
- AQUA - WATER SANITARY SEWER
- TOWN OF MOORESVILLE - WATER

- NOTE:**
1. ALL EXISTING OVERHEAD POWER ROUTING/CONNECTIVITY PROVIDED BY DUKE ENERGY AND GOOGLE EARTH. ALL EXISTING DUKE ENERGY POWER IN CONFLICT WILL BE WRECKED OUT
 2. ALL EXISTING UNDERGROUND TELECOMMUNICATIONS AND POWER IN CONFLICT WITH THE PROJECT WILL BE ABANDONED IN PLACE

RK&K
 P: (919) 878-9560
 8601 Six Forks Road, Forum 1, Suite 700
 Raleigh, North Carolina 27615-3960
 NC License No. F-0112
 Engineers | Construction Managers | Planners | Scientists
 www.rkk.com
 Responsive People | Creative Solutions

UTILITIES BY OTHERS

ALL PROPOSED UTILITY WORK SHOWN ON THIS SHEET WILL BE DONE BY OTHERS. NO PAYMENT WILL BE MADE TO THE CONTRACTOR FOR PROPOSED UTILITY WORK SHOWN ON THIS SHEET.

TGS ENGINEERS
706 HILLSBOROUGH ST., SUITE 200
RALEIGH, NC 27603
PH (919) 773-8887
CORP. LICENSE NO.: C-0275

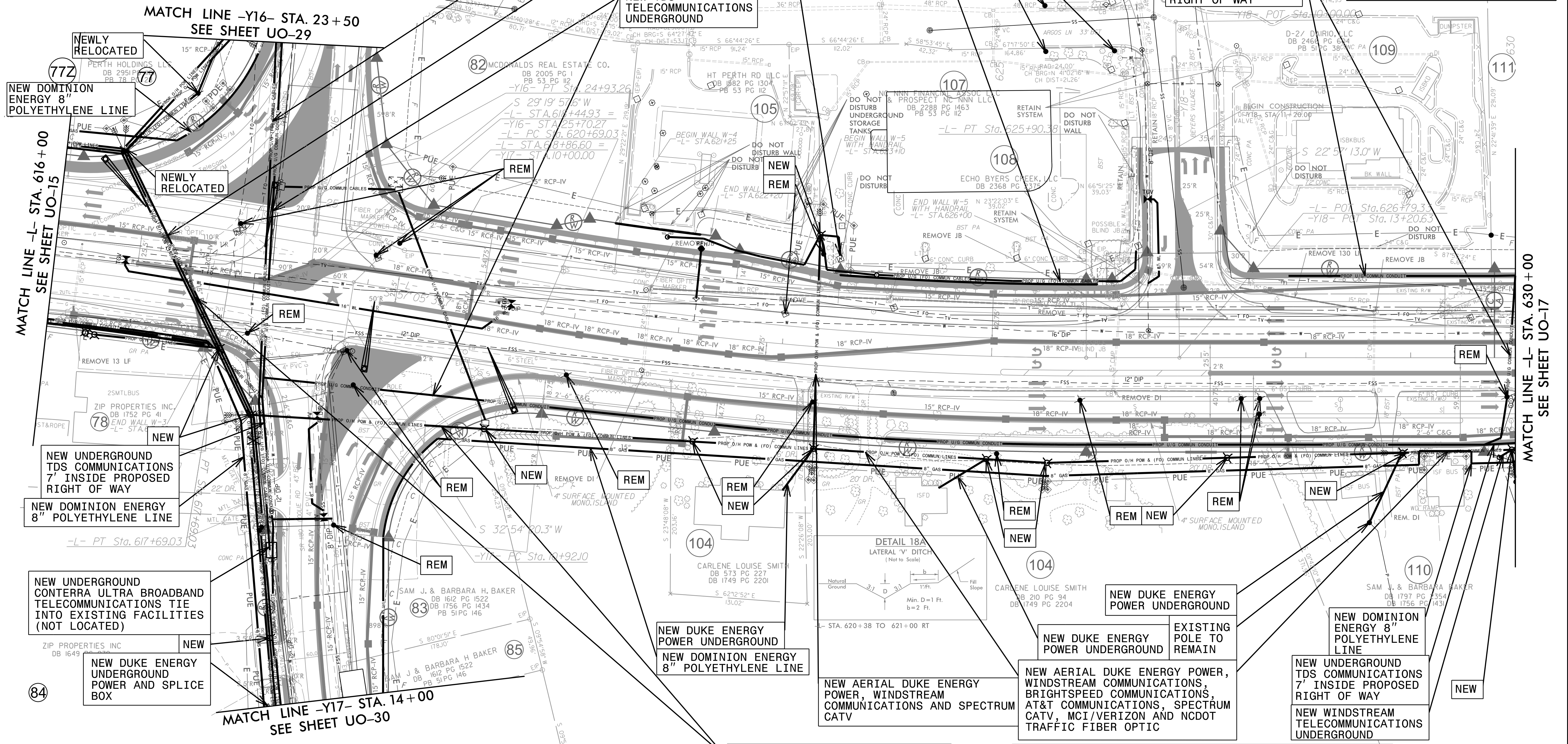
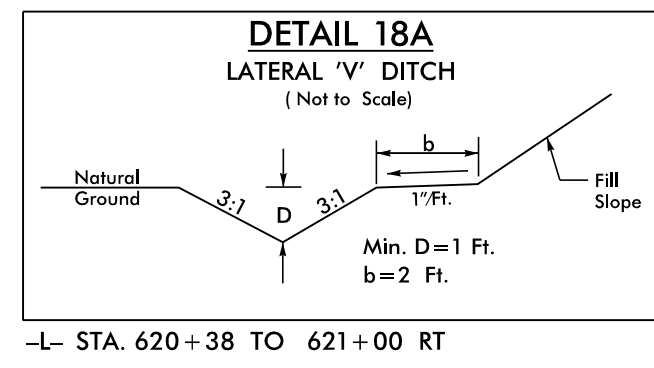
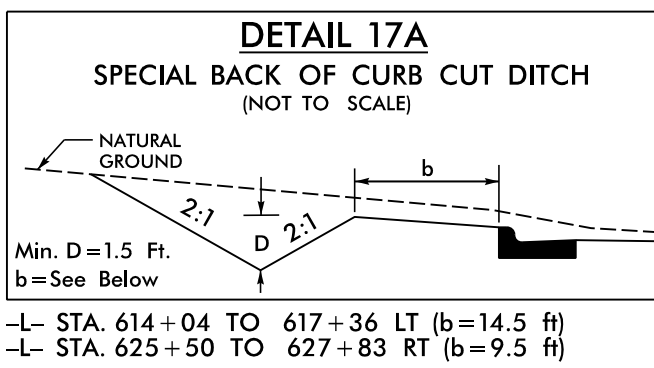

MATCH LINE -L- STA. 616+00
SEE SHEET UO-15

MATCH LINE -Y16- STA. 23+50
SEE SHEET UO-29

MATCH LINE -Y17- STA. 14+00
SEE SHEET UO-30

MATCH LINE -L- STA. 630+00
SEE SHEET UO-17

NOTE:

1. ALL EXISTING OVERHEAD POWER ROUTING/CONNECTIVITY PROVIDED BY: DUKE ENERGY AND GOOGLE EARTH. ALL EXISTING DUKE ENERGY POWER IN CONFLICT WILL BE WRECKED OUT
2. ALL EXISTING UNDERGROUND TELECOMMUNICATIONS AND POWER IN CONFLICT WITH THE PROJECT WILL BE ABANDONED IN PLACE

UTILITY OWNERS ON THIS SHEET

- DUKE POWER - POWER (D)
- DOMINION ENERGY (PSNC) - NATURAL GAS
- WINDSTREAM - TELECOMMUNICATIONS
- BRIGHTSPEED - TELECOMMUNICATIONS
- AT&T - TELECOMMUNICATIONS
- TDS - COMMUNICATIONS
- MCI/VERIZON - COMMUNICATIONS
- CONTRERA ULTRA BROADBAND - COMMUNICATIONS
- SPECTRUM - CATV
- NCDOT TRAFFIC FIBER OPTIC
- AQUA - WATER SANITARY SEWER
- TOWN OF MOORESVILLE - WATER



8/22/2024 C:\cadd\Projects\2016\16215_UO16\SA\A01_UO16\UO16\Utilities\Engineering\UBO\Pro\2307B\ut_Rdy18_UO16.psd.dgn

UTILITIES BY OTHERS

ALL PROPOSED UTILITY WORK SHOWN ON THIS SHEET WILL BE DONE BY OTHERS. NO PAYMENT WILL BE MADE TO THE CONTRACTOR FOR PROPOSED UTILITY WORK SHOWN ON THIS SHEET.

TGS ENGINEERS
706 HILLSBOROUGH ST., SUITE 200
RALEIGH, NC 27603
PH (919) 773-8887
CORP. LICENSE NO.: C-0275

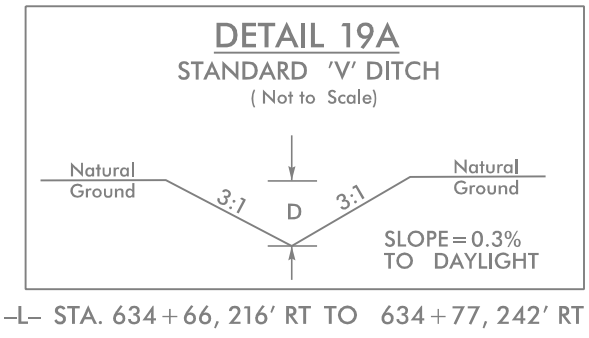

BYERS CREEK RESIDENTIAL LLC
DB 210 PG 1886
PB S/PG 38

111

NEW UNDERGROUND TDS COMMUNICATIONS 7' INSIDE PROPOSED RIGHT OF WAY

NEW AERIAL DUKE ENERGY POWER, WINDSTREAM COMMUNICATIONS, AND SPECTRUM CATV

NEW UNDERGROUND TDS COMMUNICATIONS 7' INSIDE PROPOSED RIGHT OF WAY

114

NEW DUKE ENERGY POWER UNDERGROUND

NEW DUKE ENERGY UNDERGROUND POWER AND SPLICE BOX

NEW WINDSTREAM TELECOMMUNICATIONS UNDERGROUND

EXISTING POLE TO REMAIN

NEW DOMINION ENERGY 4" POLYETHYLENE LINE

NEW

NEW

NEW

NEW

NEW

NEW

NEW

NEW

NEW

NEW

NEW

NEW

NEW

NEW

NEW

NEW

NEW

NEW

NEW

NEW

NEW

NEW

NEW

NEW

NEW

NEW DUKE ENERGY UNDERGROUND POWER AND SPLICE BOX

123

NEW UNDERGROUND TDS COMMUNICATIONS 7' INSIDE PROPOSED RIGHT OF WAY

REM

NEW

NEW

NEW

NEW

NEW

NEW

NEW

NEW

NEW

NEW

MATCH LINE -L- STA. 630+00
SEE SHEET UO-16

MATCH LINE -L- STA. 644+00
SEE SHEET UO-18

NEW DUKE ENERGY UNDERGROUND POWER AND SPLICE BOX

NEW AERIAL DUKE ENERGY POWER, WINDSTREAM COMMUNICATIONS, BRIGHTSPEED COMMUNICATIONS, AT&T COMMUNICATIONS, SPECTRUM CATV, MCI/I/VERIZON AND NCDOT TRAFFIC FIBER OPTIC

NEW DOMINION ENERGY 8" POLYETHYLENE LINE

NEW UNDERGROUND TDS COMMUNICATIONS 7' INSIDE PROPOSED RIGHT OF WAY
NEW WINDSTREAM TELECOMMUNICATIONS UNDERGROUND

NEW DUKE ENERGY UNDERGROUND POWER AND SPLICE BOX

NEW AERIAL DUKE ENERGY POWER, WINDSTREAM COMMUNICATIONS, BRIGHTSPEED COMMUNICATIONS, AT&T COMMUNICATIONS, SPECTRUM CATV, MCI/VERIZON AND NCDOT TRAFFIC FIBER OPTIC

NEW DOMINION ENERGY 8" POLYETHYLENE LINE

NEW DUKE ENERGY UNDERGROUND POWER AND SPLICE BOX

NEW DUKE ENERGY UNDERGROUND POWER AND SPLICE BOX

NEW DUKE ENERGY UNDERGROUND POWER AND SPLICE BOX

NEW DUKE ENERGY UNDERGROUND POWER AND SPLICE BOX

NEW DUKE ENERGY UNDERGROUND POWER AND SPLICE BOX

NEW DUKE ENERGY UNDERGROUND POWER AND SPLICE BOX

NEW DUKE ENERGY UNDERGROUND POWER AND SPLICE BOX

NEW DUKE ENERGY UNDERGROUND POWER AND SPLICE BOX

NEW DUKE ENERGY UNDERGROUND POWER AND SPLICE BOX

NEW DUKE ENERGY UNDERGROUND POWER AND SPLICE BOX

NEW DUKE ENERGY UNDERGROUND POWER AND SPLICE BOX

NEW DUKE ENERGY UNDERGROUND POWER AND SPLICE BOX

NEW DUKE ENERGY UNDERGROUND POWER AND SPLICE BOX

NEW DUKE ENERGY UNDERGROUND POWER AND SPLICE BOX

NEW DUKE ENERGY UNDERGROUND POWER AND SPLICE BOX

NEW DUKE ENERGY UNDERGROUND POWER AND SPLICE BOX

NEW DUKE ENERGY UNDERGROUND POWER AND SPLICE BOX

UTILITY OWNERS ON THIS SHEET

- DUKE POWER - POWER (D)
- DOMINION ENERGY (PSNC) - NATURAL GAS
- WINDSTREAM - TELECOMMUNICATIONS
- BRIGHTSPEED - TELECOMMUNICATIONS
- AT&T - TELECOMMUNICATIONS
- TDS - COMMUNICATIONS
- MCI/VERIZON - COMMUNICATIONS
- SPECTRUM - CATV
- NCDOT TRAFFIC - FIBER OPTIC
- AQUA - WATER SANITARY SEWER
- TOWN OF MOORESVILLE - WATER/SANITARY SEWER



- NOTE:
- ALL EXISTING OVERHEAD POWER ROUTING/CONNECTIVITY PROVIDED BY DUKE ENERGY AND GOOGLE EARTH. ALL EXISTING DUKE ENERGY POWER IN CONFLICT WILL BE WRECKED OUT
 - ALL EXISTING UNDERGROUND TELECOMMUNICATIONS AND POWER IN CONFLICT WITH THE PROJECT WILL BE ABANDONED IN PLACE

8/22/2024 R:\2307B\Projects\2016\16215\UO\16215_UO17.dwg User: rdj19, UO17_psh.dgn

UTILITIES BY OTHERS

ALL PROPOSED UTILITY WORK SHOWN ON THIS SHEET WILL BE DONE BY OTHERS. NO PAYMENT WILL BE MADE TO THE CONTRACTOR FOR PROPOSED UTILITY WORK SHOWN ON THIS SHEET.

TGS ENGINEERS
706 HILLSBOROUGH ST. SUITE 200
RALEIGH, NC 27603
PH (919) 773-8887
CORP. LICENSE NO.: C-0275

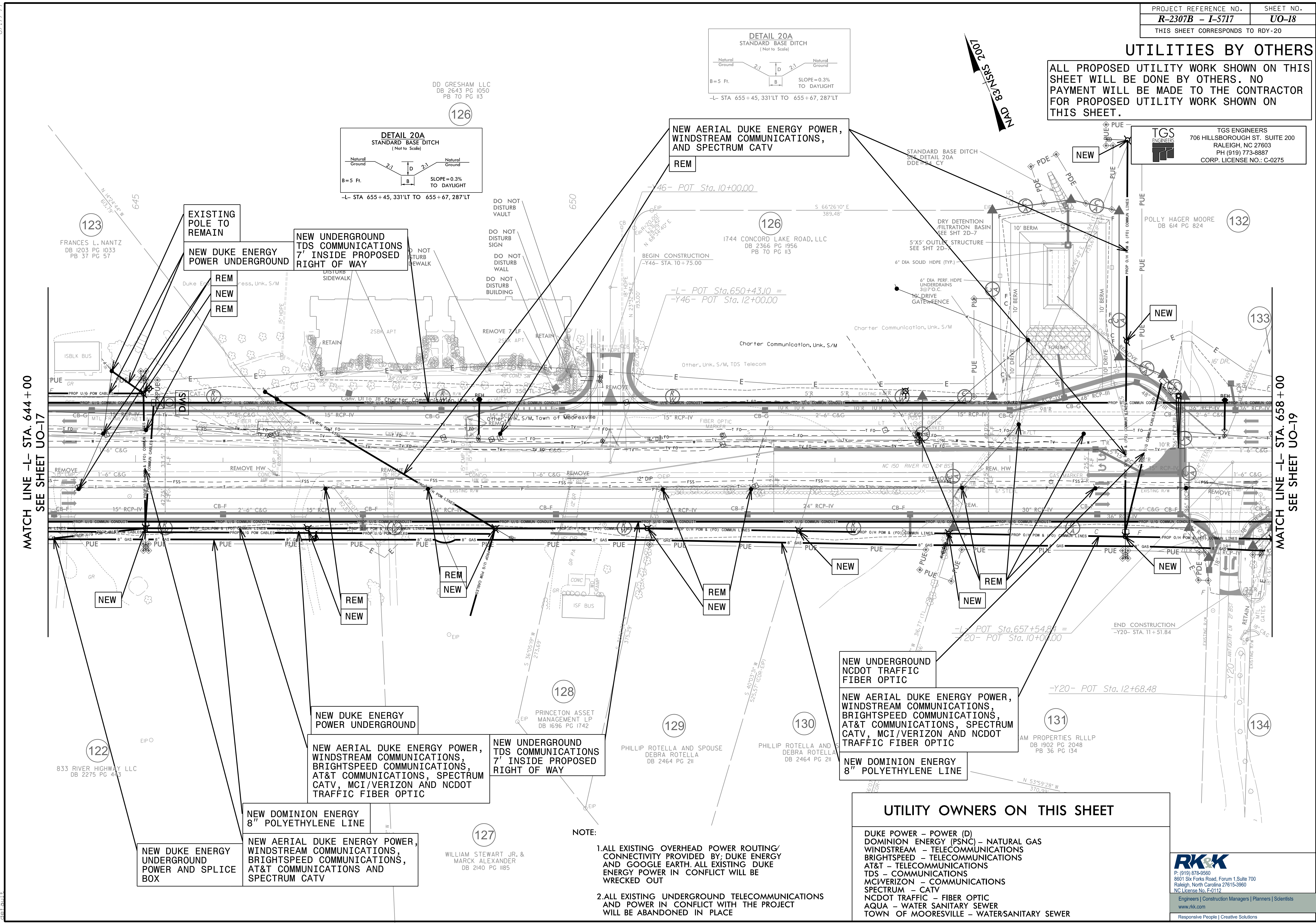
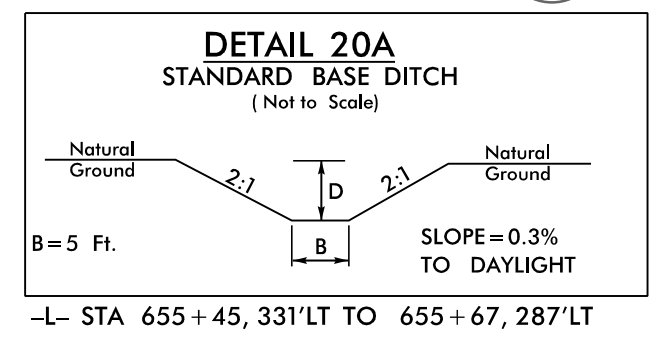
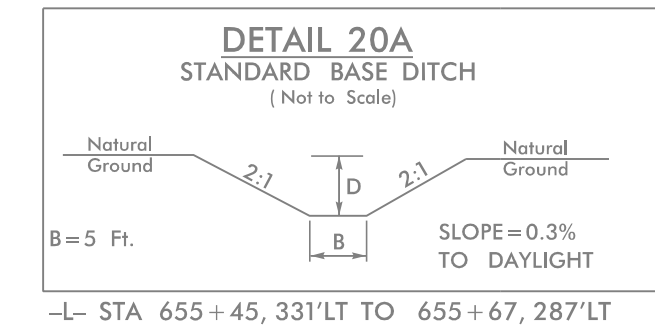

MATCH LINE -L- STA. 644+00
SEE SHEET UO-17

MATCH LINE -L- STA. 658+00
SEE SHEET UO-19

NEW UNDERGROUND NCDOT TRAFFIC FIBER OPTIC

NEW AERIAL DUKE ENERGY POWER, WINDSTREAM COMMUNICATIONS, BRIGHTSPEED COMMUNICATIONS, AT&T COMMUNICATIONS, SPECTRUM CATV, MCI/VERIZON AND NCDOT TRAFFIC FIBER OPTIC

NEW DOMINION ENERGY 8" POLYETHYLENE LINE

UTILITY OWNERS ON THIS SHEET

DUKE POWER - POWER (D)
DOMINION ENERGY (PSNC) - NATURAL GAS
WINDSTREAM - TELECOMMUNICATIONS
BRIGHTSPEED - TELECOMMUNICATIONS
AT&T - TELECOMMUNICATIONS
TDS - COMMUNICATIONS
MCI/VERIZON - COMMUNICATIONS
SPECTRUM - CATV
NCDOT TRAFFIC FIBER OPTIC
AQUA - WATER SANITARY SEWER
TOWN OF MOORESVILLE - WATERSANITARY SEWER

- NOTE:**
1. ALL EXISTING OVERHEAD POWER ROUTING/CONNECTIVITY PROVIDED BY: DUKE ENERGY AND GOOGLE EARTH. ALL EXISTING DUKE ENERGY POWER IN CONFLICT WILL BE WRECKED OUT
 2. ALL EXISTING UNDERGROUND TELECOMMUNICATIONS AND POWER IN CONFLICT WITH THE PROJECT WILL BE ABANDONED IN PLACE

RK&K
P: (919) 878-9560
8601 Six Forks Road, Forum 1, Suite 700
Raleigh, North Carolina 27615-3960
NC License No. F-0112
Engineers | Construction Managers | Planners | Scientists
www.rkk.com
Responsive People | Creative Solutions

8/17/99
8/22/2024
C:\cadd\Projects\2016\16215_UO18\SA\A01_R-2307B\Utilities\Engineering\UBD\UO18_UO18_psh.dgn

UTILITIES BY OTHERS

ALL PROPOSED UTILITY WORK SHOWN ON THIS SHEET WILL BE DONE BY OTHERS. NO PAYMENT WILL BE MADE TO THE CONTRACTOR FOR PROPOSED UTILITY WORK SHOWN ON THIS SHEET.

	TGS ENGINEERS
	706 HILLSBOROUGH ST., SUITE 200
	RALEIGH, NC 27603
	PH (919) 773-8887
CORP. LICENSE NO.: C-0275	

NOTE:

1. ALL EXISTING OVERHEAD POWER ROUTING/CONNECTIVITY PROVIDED BY DUKE ENERGY AND GOOGLE EARTH. ALL EXISTING DUKE ENERGY POWER IN CONFLICT WILL BE WRECKED OUT
2. ALL EXISTING UNDERGROUND TELECOMMUNICATIONS AND POWER IN CONFLICT WITH THE PROJECT WILL BE ABANDONED IN PLACE

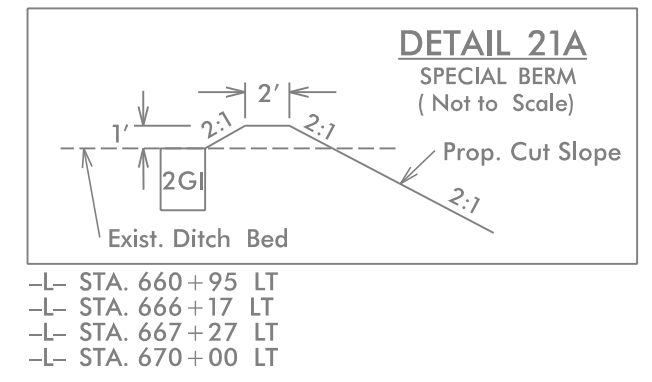

139
ROBERT H. HOWARD
DB 475 PG 431
PB 55 PG 31

139
ROBERT H. HOWARD
DB 372 PG 153
PB 55 PG 31

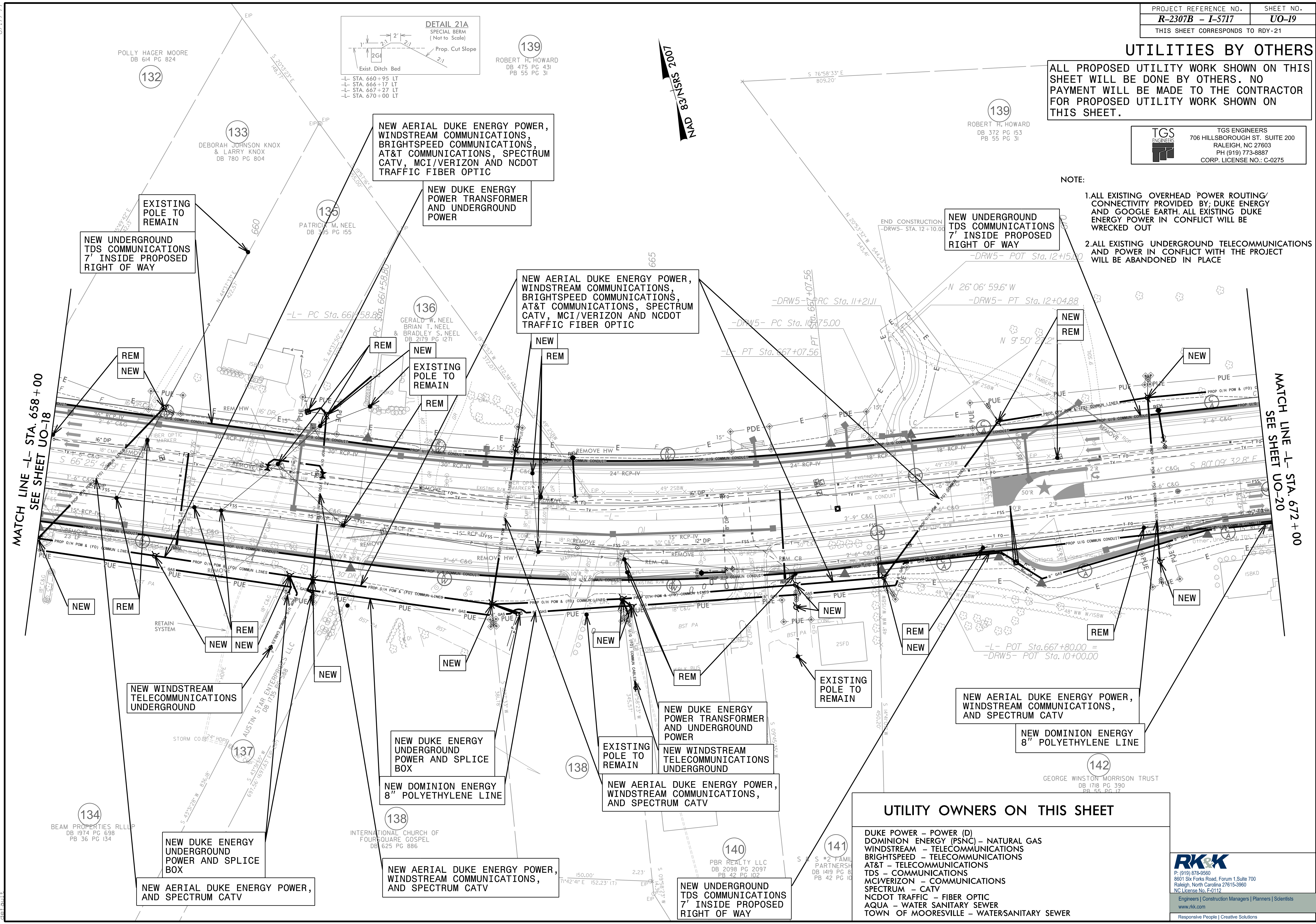

MATCH LINE -L- STA. 658+00
SEE SHEET UO-18

MATCH LINE -L- STA. 672+00
SEE SHEET UO-20

UTILITY OWNERS ON THIS SHEET

- DUKE POWER - POWER (D)
- DOMINION ENERGY (PSNC) - NATURAL GAS
- WINDSTREAM - TELECOMMUNICATIONS
- BRIGHTSPEED - TELECOMMUNICATIONS
- AT&T - TELECOMMUNICATIONS
- TDS - COMMUNICATIONS
- MCI/VERIZON - COMMUNICATIONS
- SPECTRUM - CATV
- NCDOT TRAFFIC - FIBER OPTIC
- AQUA - WATER SANITARY SEWER
- TOWN OF MOORESVILLE - WATERSANITARY SEWER

Engineers | Construction Managers | Planners | Scientists
www.rkk.com
Responsive People | Creative Solutions

8/17/2024
 R:\22\2024\Projects\2016\16215_UO1_SAY\A01_R-2307B\Utilities\Engineering\UB0\ProJ\N-2307B\Utilities\UO19_psh.dgn
 8/17/2024

UTILITIES BY OTHERS

ALL PROPOSED UTILITY WORK SHOWN ON THIS SHEET WILL BE DONE BY OTHERS. NO PAYMENT WILL BE MADE TO THE CONTRACTOR FOR PROPOSED UTILITY WORK SHOWN ON THIS SHEET.

TGS ENGINEERS
706 HILLSBOROUGH ST., SUITE 200
RALEIGH, NC 27603
PH (919) 773-8887
CORP. LICENSE NO.: C-0275

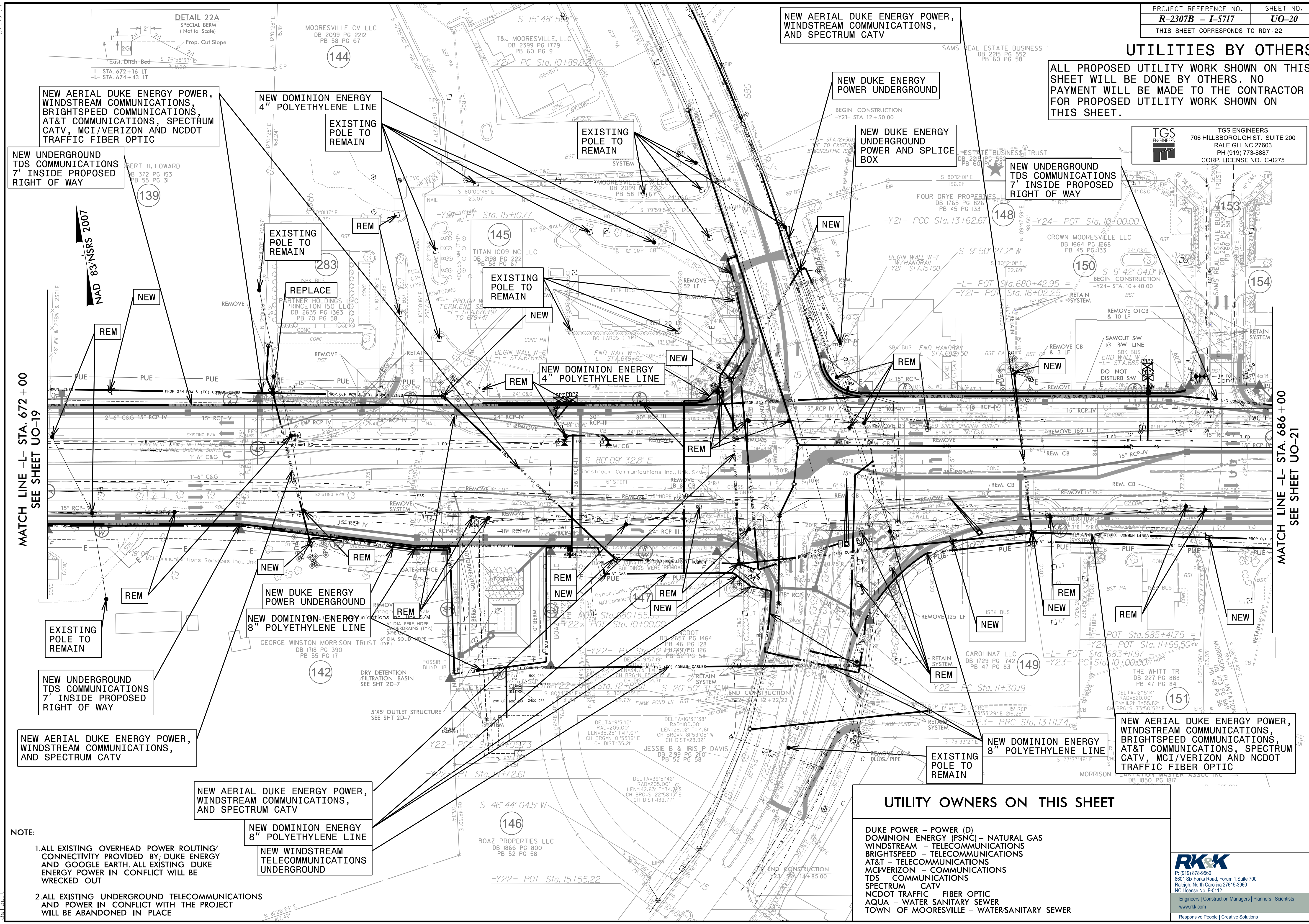

MATCH LINE -L- STA. 672+00
SEE SHEET UO-19

MATCH LINE -L- STA. 686+00
SEE SHEET UO-21

- NOTE:**
1. ALL EXISTING OVERHEAD POWER ROUTING/CONNECTIVITY PROVIDED BY: DUKE ENERGY AND GOOGLE EARTH. ALL EXISTING DUKE ENERGY POWER IN CONFLICT WILL BE WRECKED OUT
 2. ALL EXISTING UNDERGROUND TELECOMMUNICATIONS AND POWER IN CONFLICT WITH THE PROJECT WILL BE ABANDONED IN PLACE

UTILITY OWNERS ON THIS SHEET

- DUKE POWER - POWER (D)
- DOMINION ENERGY (PSNC) - NATURAL GAS
- WINDSTREAM - TELECOMMUNICATIONS
- BRIGHTSPEED - TELECOMMUNICATIONS
- AT&T - TELECOMMUNICATIONS
- MCI/VERIZON - COMMUNICATIONS
- TDS - COMMUNICATIONS
- SPECTRUM - CATV
- NCDOT TRAFFIC - FIBER OPTIC
- AQUA - WATER SANITARY SEWER
- TOWN OF MOORESVILLE - WATERSANITARY SEWER

RKK
P: (919) 878-9560
8601 Six Forks Road, Forum 1, Suite 700
Raleigh, North Carolina 27615-3960
NC License No. F-0112
Engineers | Construction Managers | Planners | Scientists
www.rkk.com
Responsive People | Creative Solutions

8/17/2024
R:\2307B\Projects\162115_UO1_SAY\01_R-2307B\Utilities\Engineering\UB0\ProJ\UO22_UO20_psh.dwg
8/17/2024

UTILITIES BY OTHERS

ALL PROPOSED UTILITY WORK SHOWN ON THIS SHEET WILL BE DONE BY OTHERS. NO PAYMENT WILL BE MADE TO THE CONTRACTOR FOR PROPOSED UTILITY WORK SHOWN ON THIS SHEET.

	TGS ENGINEERS 706 HILLSBOROUGH ST., SUITE 200 RALEIGH, NC 27603 PH (919) 773-8887 CORP. LICENSE NO.: C-0275
--	---

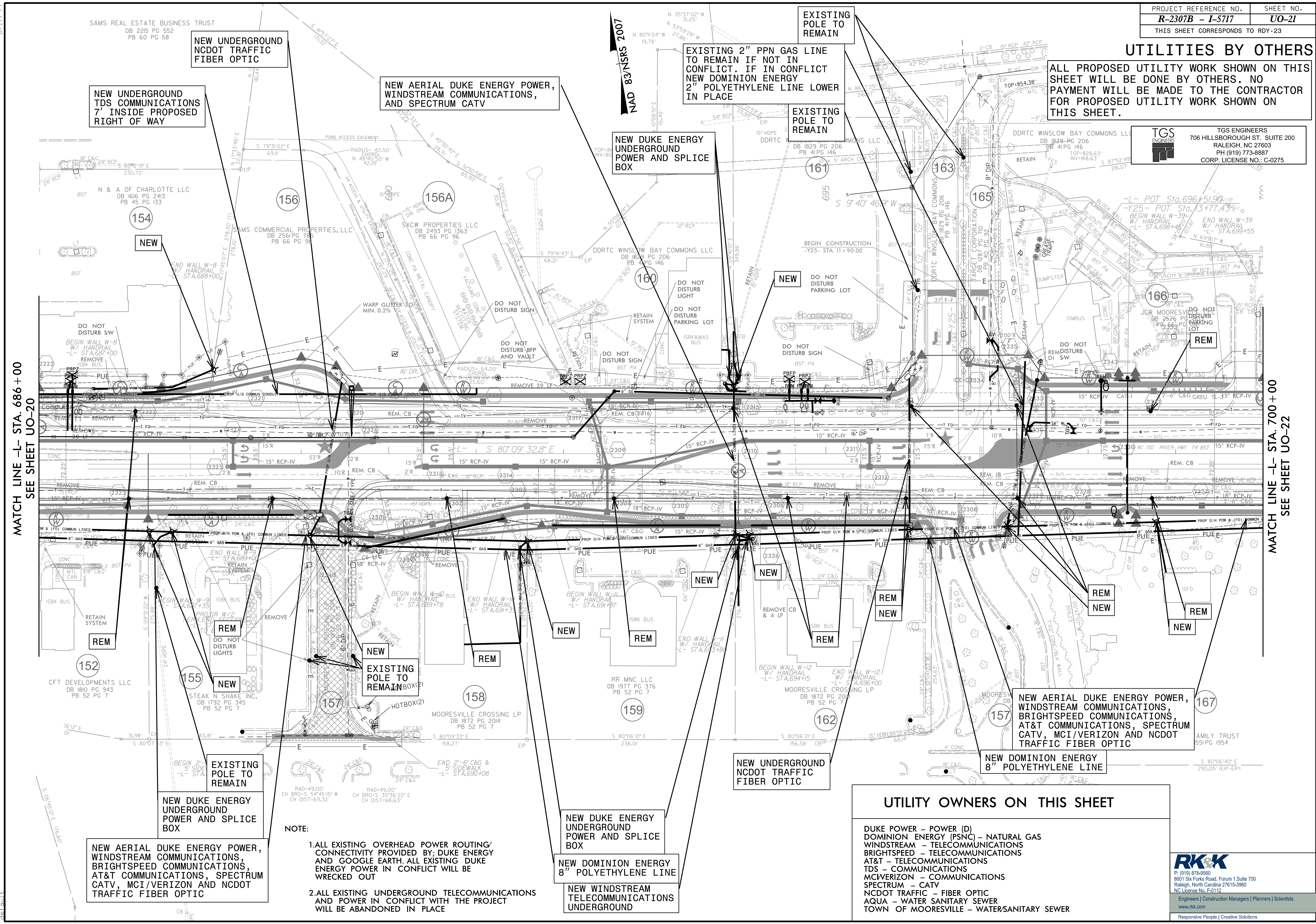

MATCH LINE -L- STA. 686 + 00
SEE SHEET UO-20

MATCH LINE -L- STA. 700 + 00
SEE SHEET UO-22

- NOTE:
1. ALL EXISTING OVERHEAD POWER ROUTING/ CONNECTIVITY PROVIDED BY: DUKE ENERGY AND GOOGLE EARTH. ALL EXISTING DUKE ENERGY POWER IN CONFLICT WILL BE WRECKED OUT
 2. ALL EXISTING UNDERGROUND TELECOMMUNICATIONS AND POWER IN CONFLICT WITH THE PROJECT WILL BE ABANDONED IN PLACE

UTILITY OWNERS ON THIS SHEET	
DUKE POWER - POWER (D)	DOMINION ENERGY (PSNC) - NATURAL GAS
WINDSTREAM - TELECOMMUNICATIONS	BRIGHTSPEED - TELECOMMUNICATIONS
AT&T - TELECOMMUNICATIONS	TDS - COMMUNICATIONS
MCIVERIZON - COMMUNICATIONS	SPECTRUM - CATV
NCDOT TRAFFIC - FIBER OPTIC	AQUA - WATER SANITARY SEWER
TOWN OF MOORESVILLE - WATERSANITARY SEWER	

P: (919) 878-9560
 8601 Six Forks Road, Forum 1, Suite 700
 Raleigh, North Carolina 27615-3960
 NC License No. F-0112
 Engineers | Construction Managers | Planners | Scientists
 www.rkk.com
 Responsive People | Creative Solutions

8/17/2024
 R:\2307B\2307B-01\Projects\2016\16215_UO\16215_UO_SAY\A01_R-2307B\Utilities\Engineering\UB0\Proje\N-2307B-ut_Rdy23_UO21_psh.dgn
 8/17/2024

UTILITIES BY OTHERS

ALL PROPOSED UTILITY WORK SHOWN ON THIS SHEET WILL BE DONE BY OTHERS. NO PAYMENT WILL BE MADE TO THE CONTRACTOR FOR PROPOSED UTILITY WORK SHOWN ON THIS SHEET.

	TGS ENGINEERS
	706 HILLSBOROUGH ST. SUITE 200
	RALEIGH, NC 27603
	PH (919) 773-8887 CORP. LICENSE NO.: C-0275

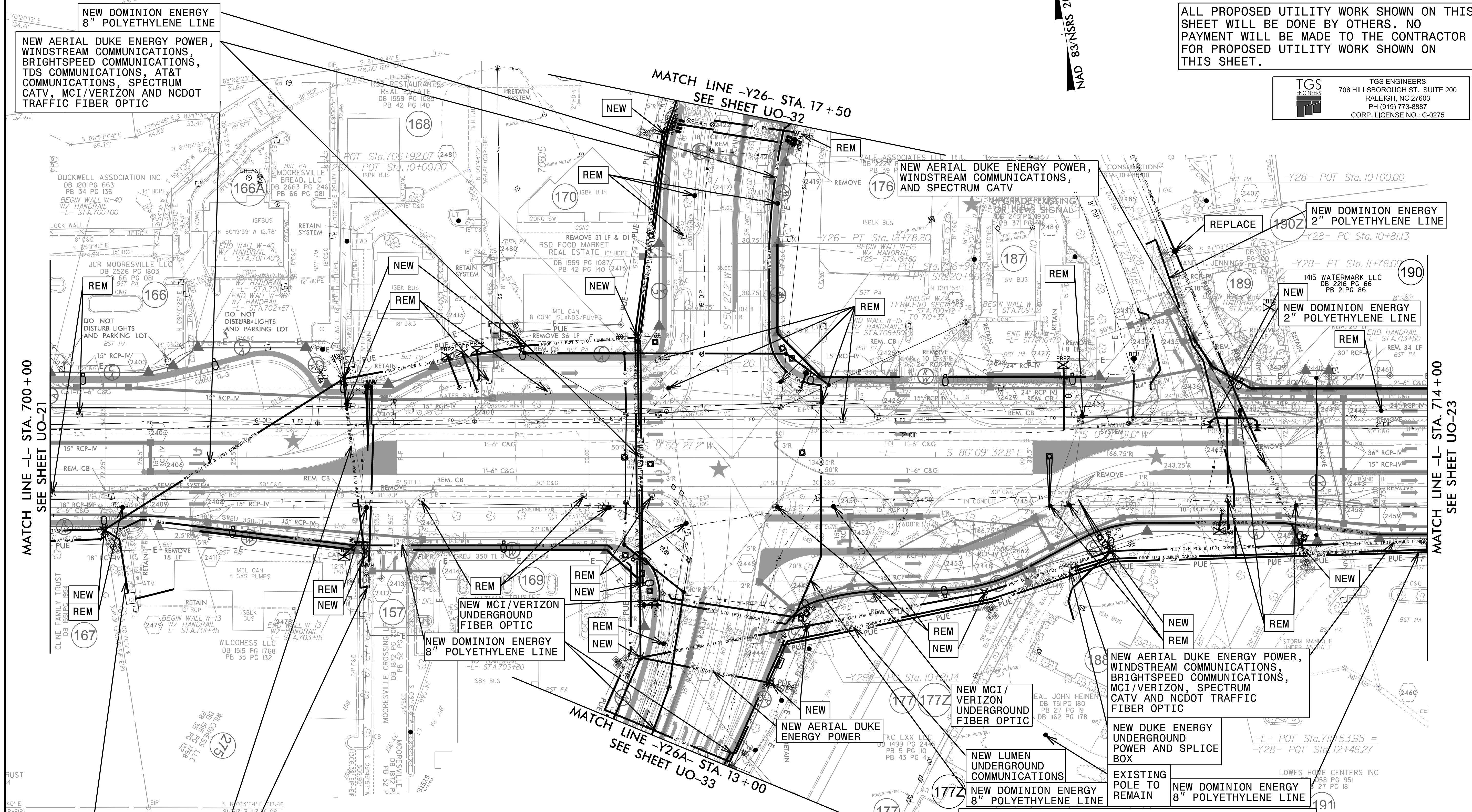

UTILITY OWNERS ON THIS SHEET

- DUKE POWER - POWER (D)
- DOMINION ENERGY (PSNC) - NATURAL GAS
- WINDSTREAM - TELECOMMUNICATIONS
- BRIGHTSPEED - TELECOMMUNICATIONS
- AT&T - TELECOMMUNICATIONS
- LEVEL 3 COMMUNICATIONS - COMMUNICATIONS
- TDS - COMMUNICATIONS
- MCIVERIZON - COMMUNICATIONS
- SPECTRUM - CATV
- NC DOT TRAFFIC - FIBER OPTIC
- AQUA - WATER SANITARY SEWER
- TOWN OF MOOREVILLE - WATERSANITARY SEWER

NOTE:

1. ALL EXISTING OVERHEAD POWER ROUTING/CONNECTIVITY PROVIDED BY DUKE ENERGY AND GOOGLE EARTH. ALL EXISTING DUKE ENERGY POWER IN CONFLICT WILL BE WRECKED OUT
2. ALL EXISTING UNDERGROUND TELECOMMUNICATIONS AND POWER IN CONFLICT WITH THE PROJECT WILL BE ABANDONED IN PLACE

RK&K
P: (919) 878-9560
8601 Six Forks Road, Forum 1, Suite 700
Raleigh, North Carolina 27615-3960
NC License No. F-0112
Engineers | Construction Managers | Planners | Scientists
www.rkk.com
Responsive People | Creative Solutions

8/17/99
8/22/2024
R:\2307B\Projects\2016\16215\UO\16215_UO\16215_UO-22.psd.dgn
R:\2307B\Projects\2016\16215\UO\16215_UO\16215_UO-22.psd.dgn
R:\2307B\Projects\2016\16215\UO\16215_UO\16215_UO-22.psd.dgn
R:\2307B\Projects\2016\16215\UO\16215_UO\16215_UO-22.psd.dgn
R:\2307B\Projects\2016\16215\UO\16215_UO\16215_UO-22.psd.dgn

UTILITIES BY OTHERS
 ALL PROPOSED UTILITY WORK SHOWN ON THIS SHEET WILL BE DONE BY OTHERS. NO PAYMENT WILL BE MADE TO THE CONTRACTOR FOR PROPOSED UTILITY WORK SHOWN ON THIS SHEET.

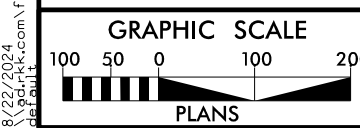
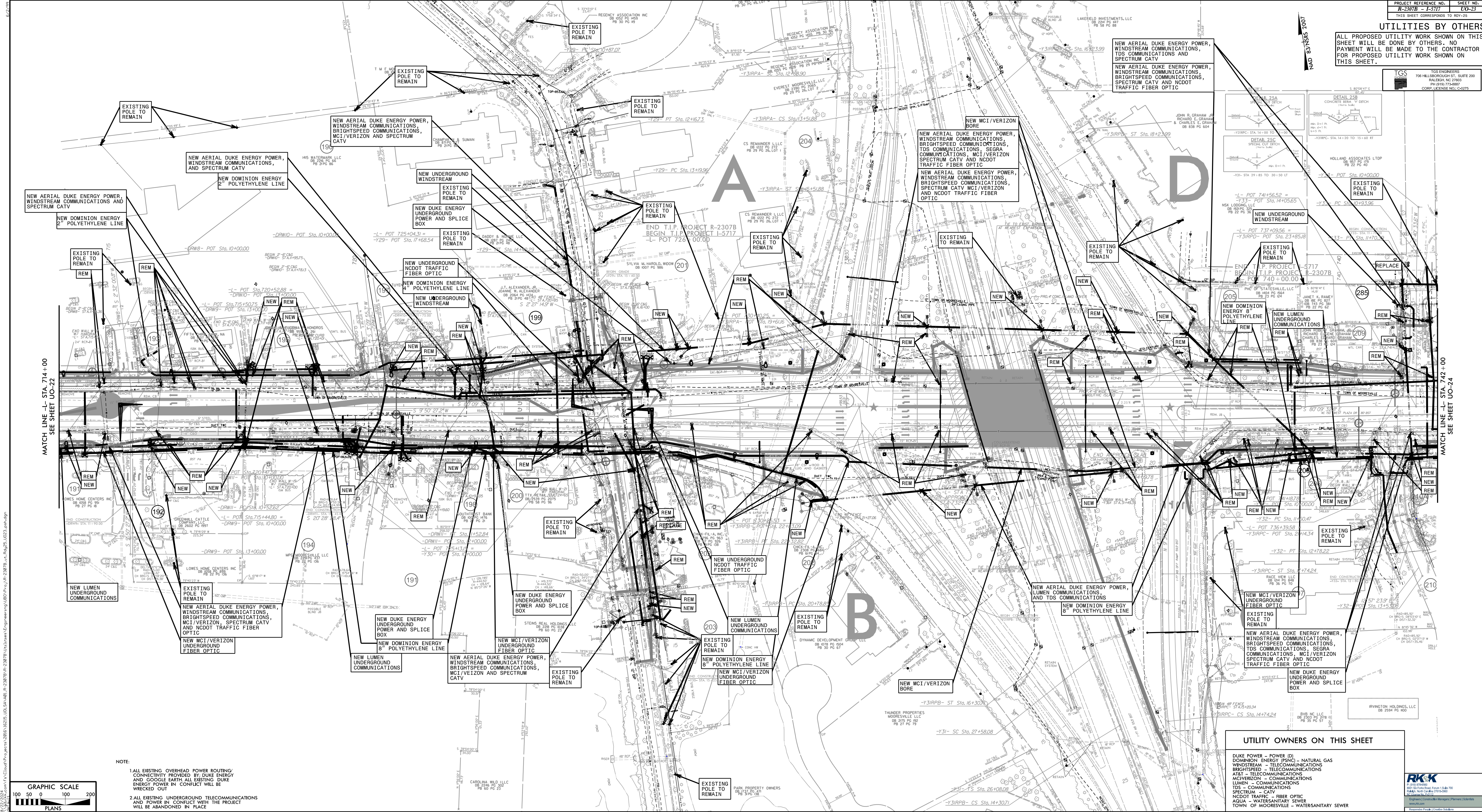
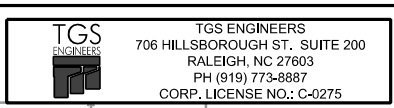

NOTE:
 1. ALL EXISTING OVERHEAD POWER ROUTING, CONNECTIVITY PROVIDED BY DUKE ENERGY AND GOOGLE EARTH. ALL EXISTING DUKE ENERGY POWER IN CONFLICT WILL BE WRECKED OUT.
 2. ALL EXISTING UNDERGROUND TELECOMMUNICATIONS AND POWER IN CONFLICT WITH THE PROJECT WILL BE ABANDONED IN PLACE.

UTILITY OWNERS ON THIS SHEET

DUKE POWER - POWER (D)
DOMINION ENERGY (PNC) - NATURAL GAS
WINDSTREAM - TELECOMMUNICATIONS
BRIGHTSPEED - TELECOMMUNICATIONS
AT&T - TELECOMMUNICATIONS
MCI/VERIZON - COMMUNICATIONS
LUMEN - COMMUNICATIONS
TDS - COMMUNICATIONS
SEGRA - COMMUNICATIONS
NCDOT TRAFFIC - FIBER OPTIC
AQUA - WATER/SANITARY SEWER
TOWN OF MOORESVILLE - WATER/SANITARY SEWER



UTILITIES BY OTHERS

ALL PROPOSED UTILITY WORK SHOWN ON THIS SHEET WILL BE DONE BY OTHERS. NO PAYMENT WILL BE MADE TO THE CONTRACTOR FOR PROPOSED UTILITY WORK SHOWN ON THIS SHEET.

TGS ENGINEERS
706 HILLSBOROUGH ST. SUITE 200
RALEIGH, NC 27603
PH (919) 773-8887
CORP. LICENSE NO.: C-0275

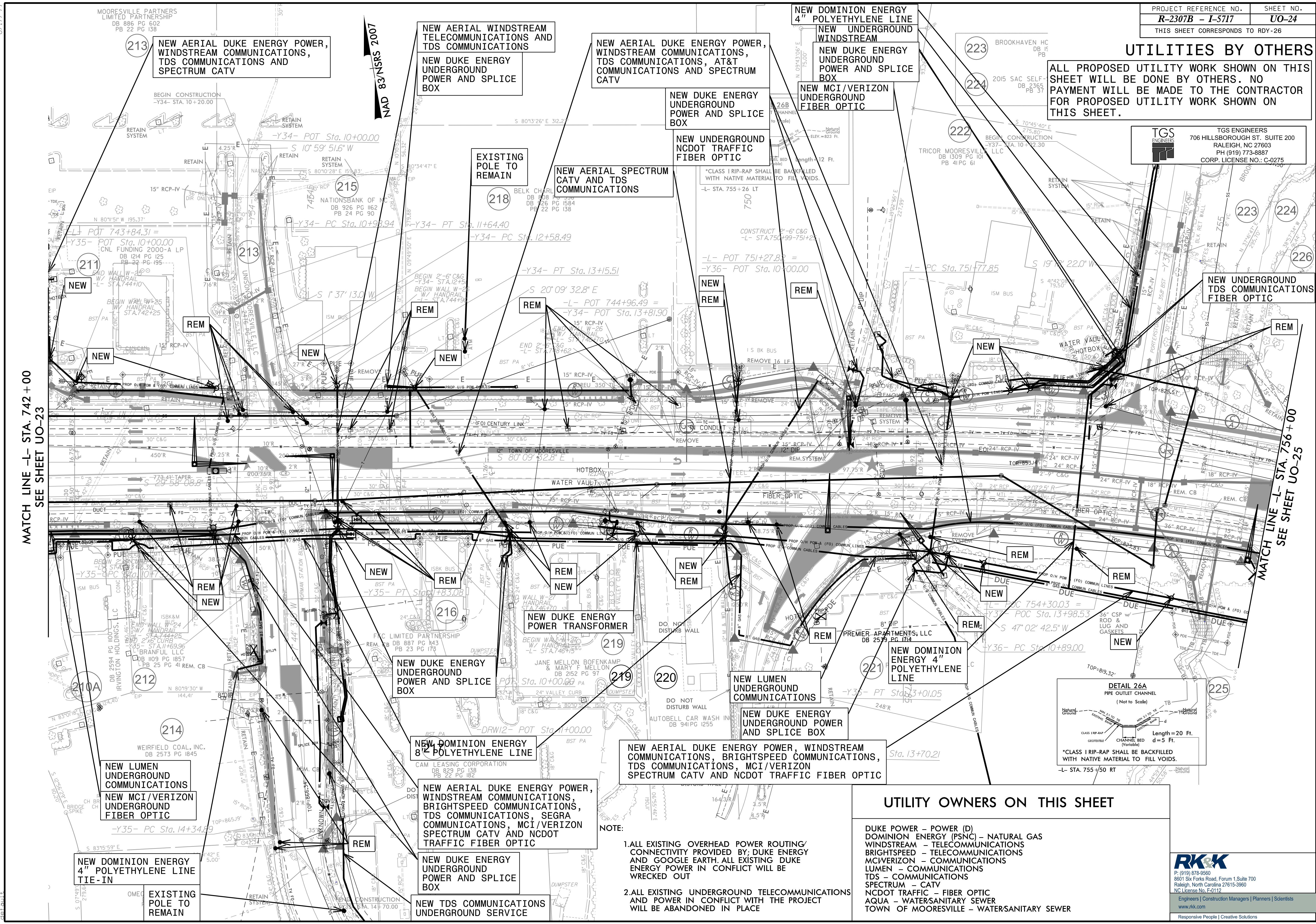

MATCH LINE -L- STA. 742 +00
SEE SHEET UO-23

MATCH LINE -L- STA. 756 +00
SEE SHEET UO-25

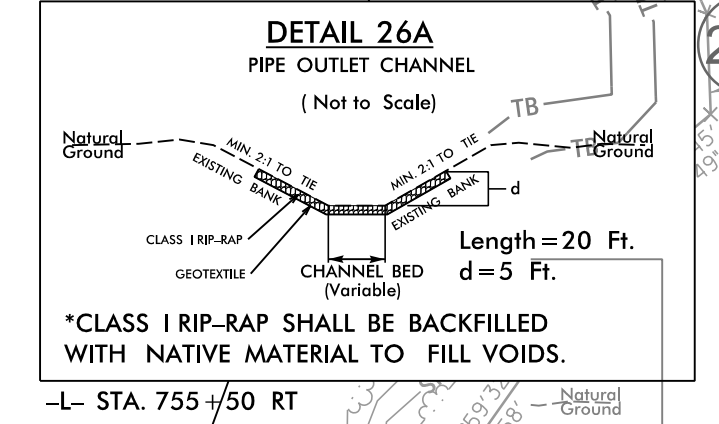

UTILITY OWNERS ON THIS SHEET

- DUKE POWER - POWER (D)
- DOMINION ENERGY (PSNC) - NATURAL GAS
- WINDSTREAM - TELECOMMUNICATIONS
- BRIGHTSPEED - TELECOMMUNICATIONS
- MCIVERIZON - COMMUNICATIONS
- LUMEN - COMMUNICATIONS
- TDS - COMMUNICATIONS
- SPECTRUM - CATV
- NC DOT TRAFFIC - FIBER OPTIC
- AQUA - WATERSANITARY SEWER
- TOWN OF MOORESVILLE - WATERSANITARY SEWER

- NOTE:
- ALL EXISTING OVERHEAD POWER ROUTING/CONNECTIVITY PROVIDED BY DUKE ENERGY AND GOOGLE EARTH. ALL EXISTING DUKE ENERGY POWER IN CONFLICT WILL BE WRECKED OUT
 - ALL EXISTING UNDERGROUND TELECOMMUNICATIONS AND POWER IN CONFLICT WITH THE PROJECT WILL BE ABANDONED IN PLACE



8/17/2024 R:\2307B\Projects\2016\16215\UOL_SAY\A01_R-2307B\Utilities\Engineering\UBO\N-2307B_U024_psh.dgn

UTILITIES BY OTHERS

ALL PROPOSED UTILITY WORK SHOWN ON THIS SHEET WILL BE DONE BY OTHERS. NO PAYMENT WILL BE MADE TO THE CONTRACTOR FOR PROPOSED UTILITY WORK SHOWN ON THIS SHEET.

TGS ENGINEERS
706 HILLSBOROUGH ST., SUITE 200
RALEIGH, NC 27603
PH (919) 773-8887
CORP. LICENSE NO.: C-0275

CAROLINA PROJECTS LTD
DB 955 PG 1390

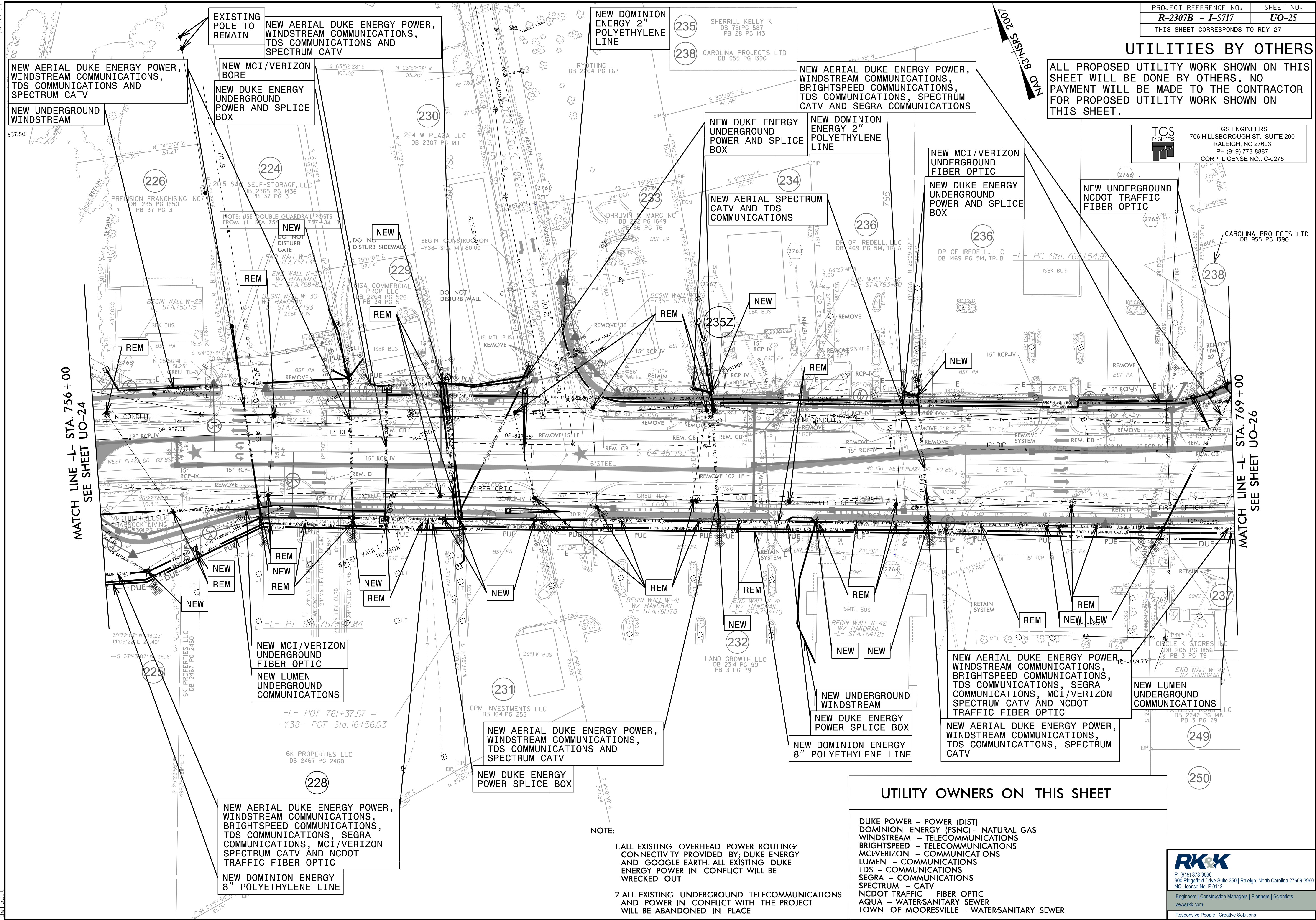

MATCH LINE -L- STA. 756 + 00
SEE SHEET UO-24

MATCH LINE -L- STA. 769 + 00
SEE SHEET UO-26

UTILITY OWNERS ON THIS SHEET

- DUKE POWER - POWER (DIST)
- DOMINION ENERGY (PSNC) - NATURAL GAS
- WINDSTREAM - TELECOMMUNICATIONS
- BRIGHTSPEED - TELECOMMUNICATIONS
- MCIVERIZON - COMMUNICATIONS
- LUMEN - COMMUNICATIONS
- TDS - COMMUNICATIONS
- SEGRA - COMMUNICATIONS
- SPECTRUM - CATV
- NC DOT TRAFFIC - FIBER OPTIC
- AQUA - WATER/SANITARY SEWER
- TOWN OF MOORESVILLE - WATER/SANITARY SEWER

- NOTE:**
1. ALL EXISTING OVERHEAD POWER ROUTING/CONNECTIVITY PROVIDED BY DUKE ENERGY AND GOOGLE EARTH. ALL EXISTING DUKE ENERGY POWER IN CONFLICT WILL BE WRECKED OUT
 2. ALL EXISTING UNDERGROUND TELECOMMUNICATIONS AND POWER IN CONFLICT WITH THE PROJECT WILL BE ABANDONED IN PLACE