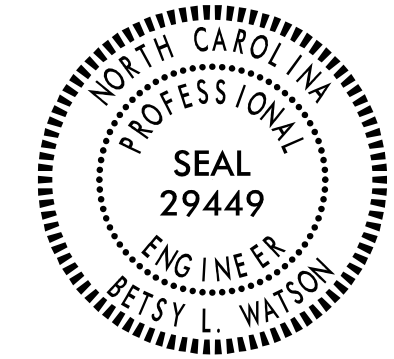

CONTRACT NO.: C204348 **T.I.P.: R-2307B & I-5717**

STATE OF NORTH CAROLINA
DEPARTMENT OF TRANSPORTATION

PAVEMENT MARKING PLAN
CATAWBA & IREDELL COUNTIES

LOCATION: NC 150 FROM SR 1840 (GREENWOOD RD) IN
CATAWBA COUNTY TO US 21 IN IREDELL COUNTY

TIP NO. R-2307B & I-5717	SHEET NO. PMP-1
Documented by: APPROVED: <i>Betsy L. Watson</i> <small>05E97854F8743F</small>	
DATE: 8/15/2024	
	
DOCUMENT NOT CONSIDERED FINAL UNLESS ALL SIGNATURES COMPLETED	

ROADWAY STANDARD DRAWINGS

THE FOLLOWING ROADWAY STANDARDS AS APPEAR IN "ROADWAY STANDARD DRAWINGS" - PROJECT SERVICES UNIT - N.C. DEPARTMENT OF TRANSPORTATION - RALEIGH, N.C., DATED JANUARY 2024 ARE APPLICABLE TO THIS PROJECT AND BY REFERENCE HEREBY ARE CONSIDERED A PART OF THESE PLANS:

STD. NO.	TITLE
1205.01	PAVEMENT MARKINGS - LINE TYPES & OFFSETS
1205.02	PAVEMENT MARKINGS - 2 LANE & MULTILANE ROADWAYS
1205.04	PAVEMENT MARKINGS - INTERSECTIONS
1205.05	PAVEMENT MARKINGS - TURN LANES
1205.06	PAVEMENT MARKINGS - LANE DROP
1205.07	PAVEMENT MARKINGS - PEDESTRIAN CROSSWALKS
1205.08	PAVEMENT MARKINGS - SYMBOLS & WORD MESSAGES
1205.09	PAVEMENT MARKINGS - PAINTED ISLANDS
1205.10	PAVEMENT MARKINGS - SCHOOL AREAS
1205.12	PAVEMENT MARKINGS - BRIDGES
1205.13	PAVEMENT MARKINGS - LANE REDUCTIONS
1205.15	PAVEMENT MARKINGS - REDUCED CONFLICT INTERSECTIONS
1205.16	PAVEMENT MARKINGS - BICYCLE FACILITIES
1250.01	RAISED PAVEMENT MARKERS - INSTALLATION SPACING (REPLACE SHEET 2 OF 3 WITH PMP-1A)
1251.01	RAISED PAVEMENT MARKERS - PERMANENT AND TEMPORARY
1261.01	GUARDRAIL & BARRIER DELINEATORS - INSTALLATION SPACING
1261.02	GUARDRAIL & BARRIER DELINEATORS - TYPES & MOUNTING
1262.01	GUARDRAIL END DELINEATION

GENERAL NOTES

THE FOLLOWING GENERAL NOTES APPLY AT ALL TIMES FOR THE DURATION OF THE CONSTRUCTION PROJECT, EXCEPT WHEN OTHERWISE NOTED IN THE PLAN, OR DIRECTED BY THE ENGINEER.

- A) INSTALL PAVEMENT MARKINGS AND PAVEMENT MARKERS ON THE FINAL SURFACE AS FOLLOWS:

ROAD NAME	MARKING	MARKER
ALL ROADS	POLYUREA	SNOWPLOWABLE
BRIDGES	POLYUREA	RAISED
- B) TIE PROPOSED PAVEMENT MARKING LINES TO EXISTING PAVEMENT MARKING LINES.
- C) REMOVE/REPLACE ANY CONFLICTING/DAMAGED PAVEMENT MARKINGS AND MARKERS.
- D) PASSING ZONES WILL BE DETERMINED IN THE FIELD AND MUST BE APPROVED BY THE ENGINEER.
- E) STOP BAR LOCATION AT NON-SIGNALIZED INTERSECTIONS MAY BE ADJUSTED AS DIRECTED BY THE ENGINEER.
- F) REMOVE ALL RESIDUE AND SURFACE LAITANCE BY ACCEPTABLE METHODS ON CONCRETE BRIDGE DECKS PRIOR TO PLACING POLYUREA PAVEMENT MARKING MATERIAL.
- G) UNLESS OTHERWISE SPECIFIED, HEATED-IN-PLACE THERMOPLASTIC MAY BE USED IN LIEU OF EXTRUDED THERMOPLASTIC FOR STOP BARS, SYMBOLS, CHARACTERS AND DIAGONALS.
- H) ALL BICYCLE LANE SYMBOLS SHALL BE HEATED-IN-PLACE THERMOPLASTIC. SYMBOLS SHALL BE PAID FOR USING THE HEATED-IN-PLACE PAY ITEM.
- I) SEE ROADWAY PLANS FOR ALTERNATE CURB RAMP DESIGNS WHEN INDICATED ON PAVEMENT MARKING DETAIL SHEETS.

FINAL PAVEMENT MARKING SCHEDULE

SYMBOL	DESCRIPTION	PAY ITEM
T1	WHITE EDGELINE	(4", 90 MILS) THERMOPLASTIC
T41	WHITE DIAGONAL	(8", 90 MILS) THERMOPLASTIC
T42	YELLOW DIAGONAL	(8", 90 MILS) THERMOPLASTIC
T46	WHITE CROSSWALK LINE	(8", 90 MILS) THERMOPLASTIC
T51	WHITE DIAGONAL	(12", 90 MILS) THERMOPLASTIC
T52	YELLOW DIAGONAL	(12", 90 MILS) THERMOPLASTIC
T61	WHITE STOPBAR	(24", 90 MILS) THERMOPLASTIC
T62	WHITE CROSSWALK LINE	(24", 90 MILS) THERMOPLASTIC
T70	LEFT TURN ARROW	(90 MILS) THERMOPLASTIC
T71	RIGHT TURN ARROW	(90 MILS) THERMOPLASTIC
T72	STRAIGHT ARROW	(90 MILS) THERMOPLASTIC
T73	COMBO LEFT/STRAIGHT ARROW	(90 MILS) THERMOPLASTIC
T74	COMBO STRAIGHT/RIGHT ARROW	(90 MILS) THERMOPLASTIC
T77	U-TURN ARROW	(90 MILS) THERMOPLASTIC
T79	MERGE ARROW	(90 MILS) THERMOPLASTIC
T80	WRONG-WAY RAMP ARROW	(90 MILS) THERMOPLASTIC
T90	BICYCLE SYMBOL, HEATED-IN-PLACE	(90 MILS) THERMOPLASTIC
T91	BICYCLE STRAIGHT ARROW, HEATED-IN-PLACE	(90 MILS) THERMOPLASTIC
T93	BICYCLE CHARACTER, HEATED-IN-PLACE	(120 MILS) THERMOPLASTIC
T100	ALPHANUMERIC CHARACTER	(90 MILS) THERMOPLASTIC
T103	24" YIELD LINE TRIANGLE	(90 MILS) THERMOPLASTIC
T104	ROUTE SHIELD 6 FT X 15 FT	(90 MILS) THERMOPLASTIC
T119	COMBO U-TURN/STRAIGHT ARROW	(90 MILS) THERMOPLASTIC
V1	WHITE EDGELINE	(4", 30 MILS) POLYUREA
V2	WHITE SOLID LANE LINE	(4", 30 MILS) POLYUREA
V3	10 FT WHITE SKIP	(4", 30 MILS) POLYUREA
V4	3 FT-9 FT/SP WHITE MINISKIP	(4", 30 MILS) POLYUREA
V5	2 FT-6FT/SP WHITE MINISKIP	(4", 30 MILS) POLYUREA
V10	YELLOW EDGELINE	(4", 30 MILS) POLYUREA
V13	YELLOW DOUBLE CENTER	(4", 30 MILS) POLYUREA
V14	2 FT-6FT/SP YELLOW MINISKIP	(4", 30 MILS) POLYUREA
V20	WHITE EDGELINE	(6", 30 MILS) POLYUREA
V21	WHITE SOLID LANE LINE	(6", 30 MILS) POLYUREA
V22	10 FT WHITE SKIP	(6", 30 MILS) POLYUREA
V23	3 FT-9 FT/SP WHITE MINISKIP	(6", 30 MILS) POLYUREA
V30	YELLOW EDGELINE	(6", 30 MILS) POLYUREA
V40	WHITE GORELINE	(8", 30 MILS) POLYUREA
V43	WHITE SOLID LANE LINE	(8", 30 MILS) POLYUREA
V44	3 FT-9 FT/SP WHITE MINISKIP	(8", 30 MILS) POLYUREA
V50	WHITE GORELINE	(12", 30 MILS) POLYUREA

INDEX

_SHEET NO.	_DESCRIPTION
PMP-1	PAVEMENT MARKING PLAN TITLE AND SCHEDULE SHEET
PMP-1A	REVISED ROADWAY STANDARD DRAWING
PMP-1B	DETAIL OF INLAID RAISED PAVEMENT MARKER
PMP-1C	DETAIL OF INLAID CRADLE MARKER
PMP-1D	DETAIL OF MILLED RUMBLE SKIPS
PMP-2-45	PAVEMENT MARKING DETAIL

PLAN REVIEWED BY: N.C.D.O.T. SIGNING AND DELINEATION UNIT

KELVIN JORDAN SIGNING & DELINEATION REGIONAL ENGINEER

ERIC WARD SIGNING & DELINEATION PROJECT DESIGN ENGINEER

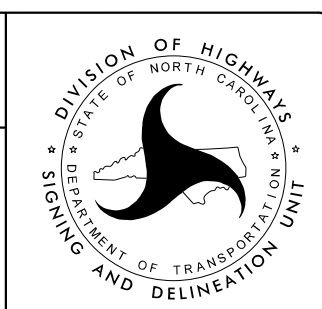

PLAN PREPARED BY:

BETSY L. WATSON, P.E. SENIOR TRANSPORTATION ENGINEER

ROSI R. HENNEIN TRANSPORTATION DESIGNER



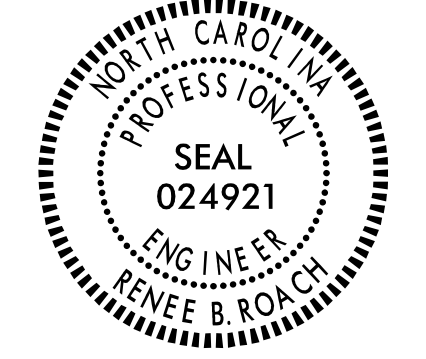

Stantec Consulting Services Inc.
801 Jones Franklin Road
Suite 300
Raleigh, NC 27606
Tel. (919) 851-6866
Fax. (919) 851-7024
www.stantec.com
License No. F-0672

TIP NO. R-2307B & I-5717	SHEET NO. PMP-1A
APPROVED: <i>Kenee B. Roach, PE</i>	
DATE: 8/16/2024	
SEAL	
	
DOCUMENT NOT CONSIDERED FINAL UNLESS ALL SIGNATURES COMPLETED	

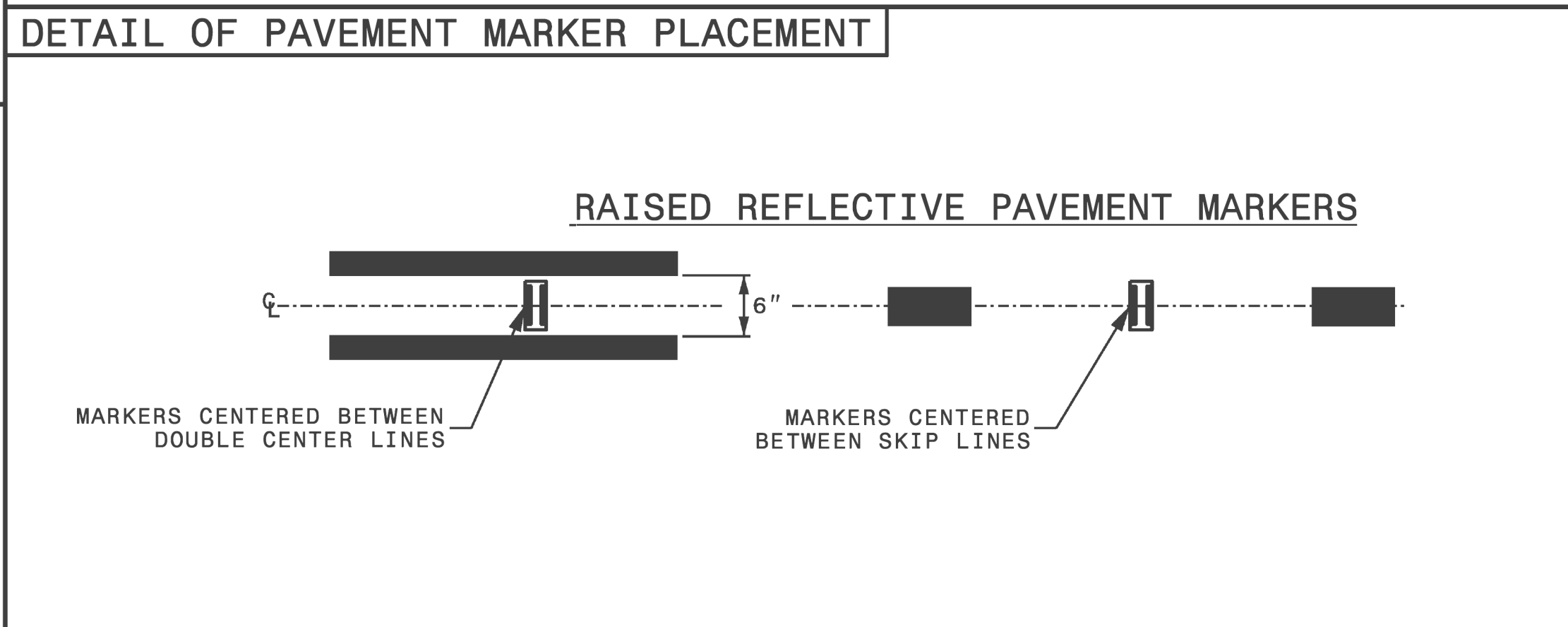
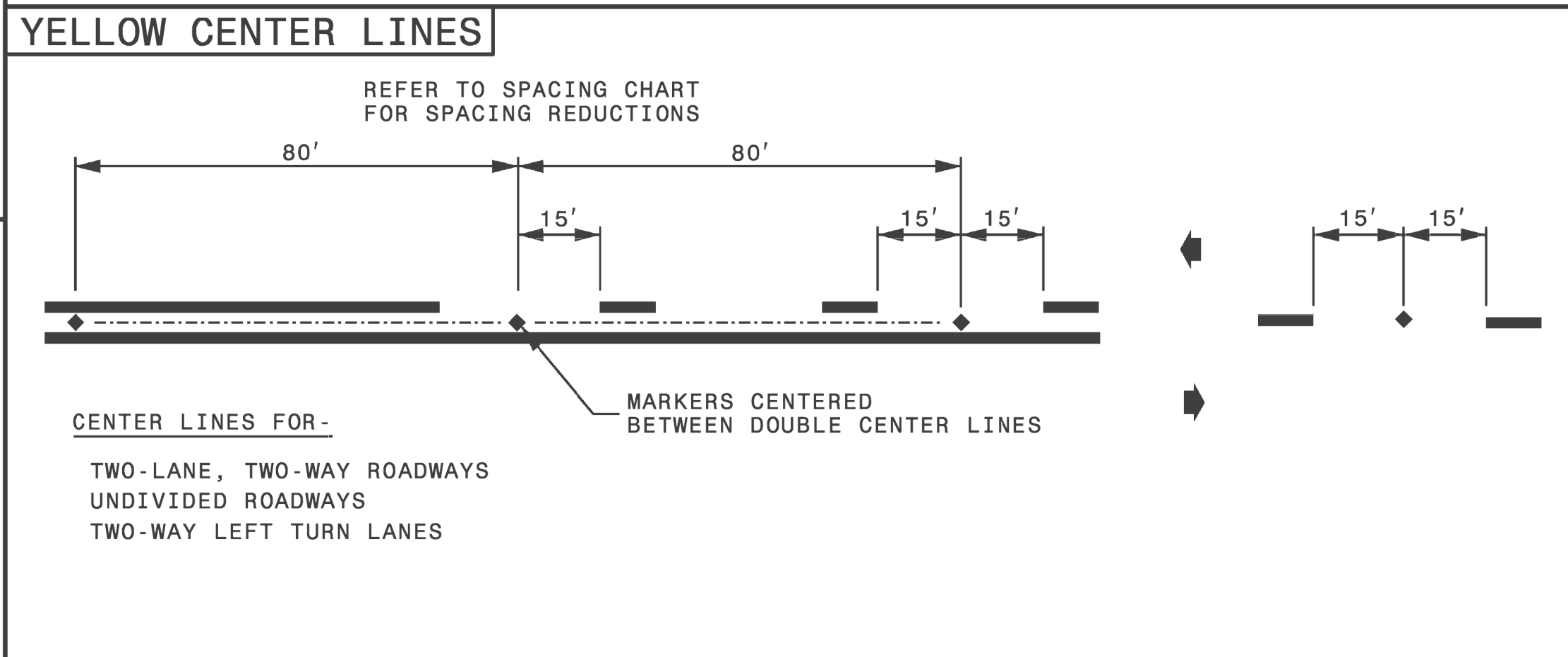
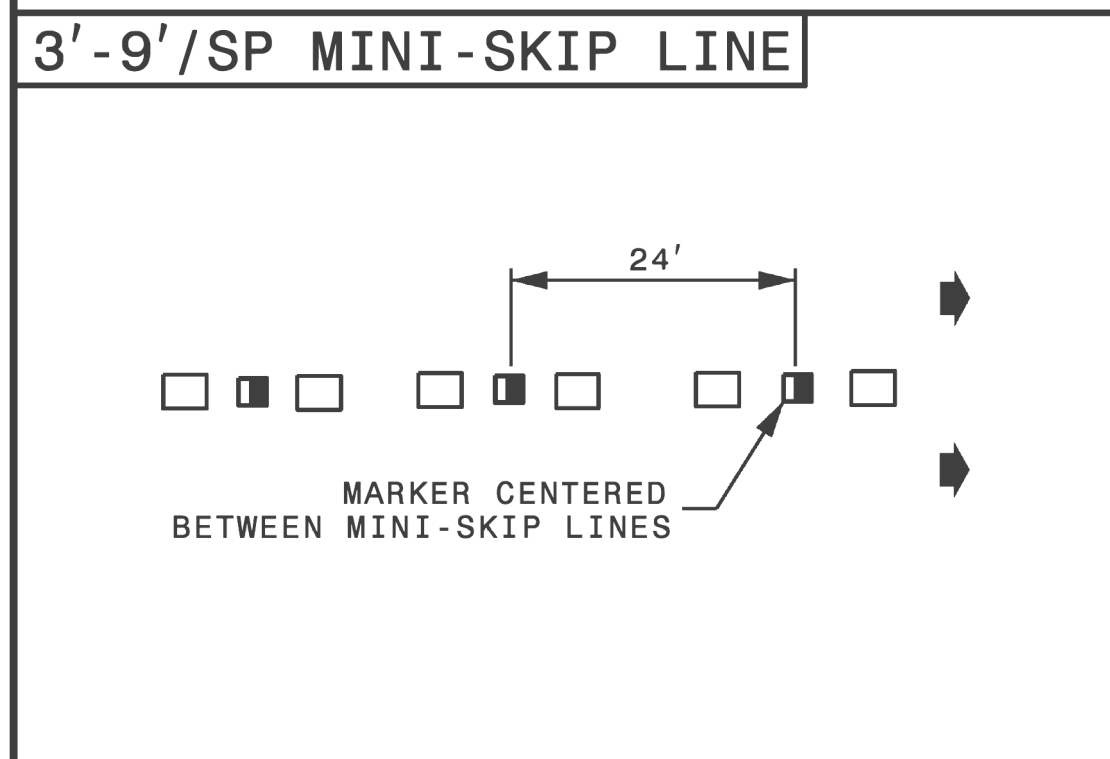
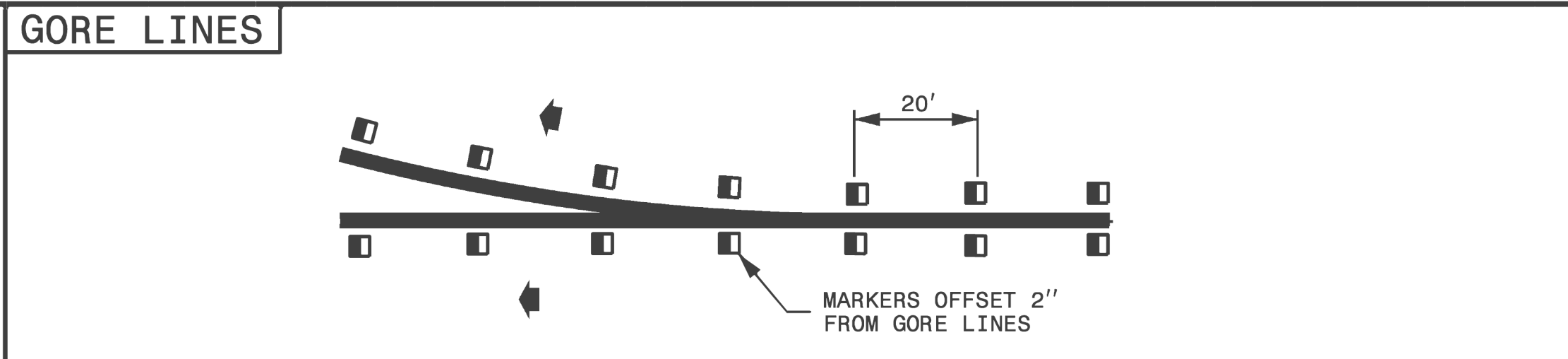
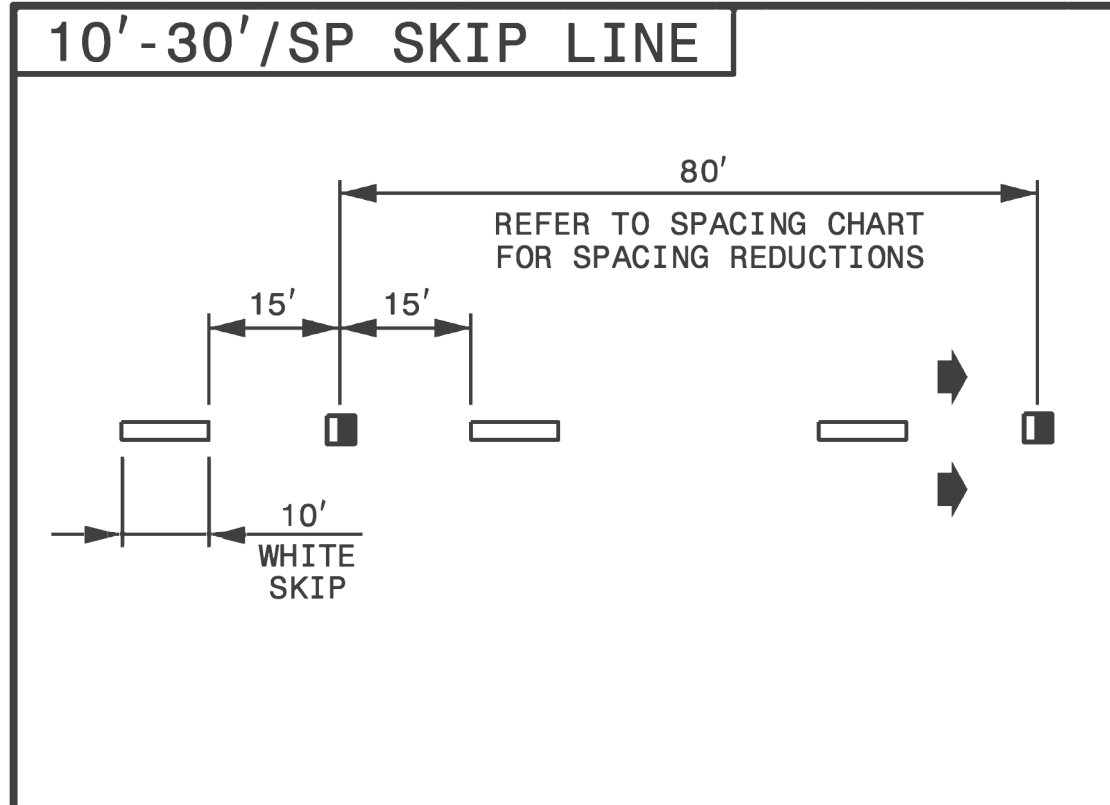
PROJECT REFERENCE NO.	SHEET NO.
-----------------------	-----------



LEGEND

	CRYSTAL/RED PAVEMENT MARKER
	YELLOW/YELLOW PAVEMENT MARKER
	DIRECTION OF TRAFFIC FLOW

STATE OF NORTH CAROLINA
DEPT. OF TRANSPORTATION
DIVISION OF HIGHWAYS
RALEIGH, N.C.

ROADWAY DETAIL DRAWING FOR
RAISED PAVEMENT MARKERS
INSTALLATION SPACING

SHEET 2 OF 3
1250D01

CONTRACTS STANDARDS AND DEVELOPMENT UNIT
Office 919-707-8950 FAX 919-250-4119

SEE TITLE BLOCK

ORIGINAL BY: M.V. SPRINGER	DATE: 2-15-24
MODIFIED BY:	DATE:
CHECKED BY:	DATE:
FILE SPEC.:	

REVISED ROADWAY
STANDARD DRAWING

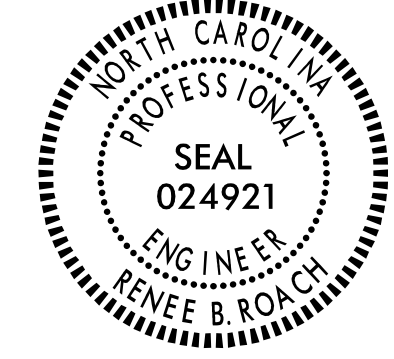
TIP NO. R-2307B & I-5717	SHEET NO. PMP-1B
APPROVED: <u>Kenneth B. Roach, P.E.</u> <small>DocuSigned by: Kenneth B. Roach, P.E. 3EB430B0516491</small>	
DATE: 8/16/2024	
SEAL	
	
DOCUMENT NOT CONSIDERED FINAL UNLESS ALL SIGNATURES COMPLETED	

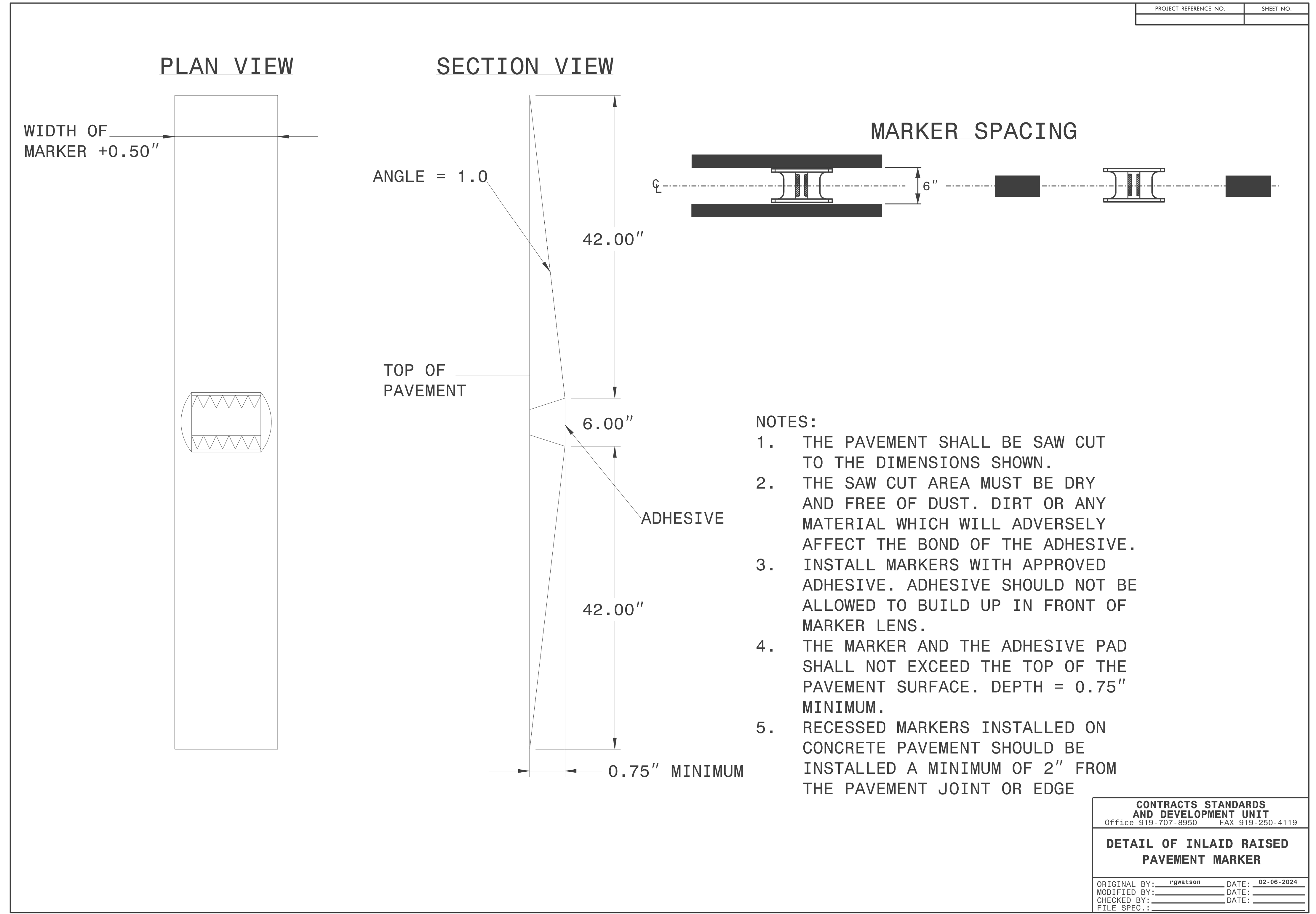

**DETAIL OF INLAID
RAISED PAVEMENT MARKER**

TIP NO. R-2307B & I-5717	SHEET NO. PMP-1C
APPROVED: <i>Kene B. Roach, PE</i> <small>DocuSigned by: KENE B. ROACH, PE 3EB430B0516491</small>	
DATE: 8/16/2024	
	
DOCUMENT NOT CONSIDERED FINAL UNLESS ALL SIGNATURES COMPLETED	

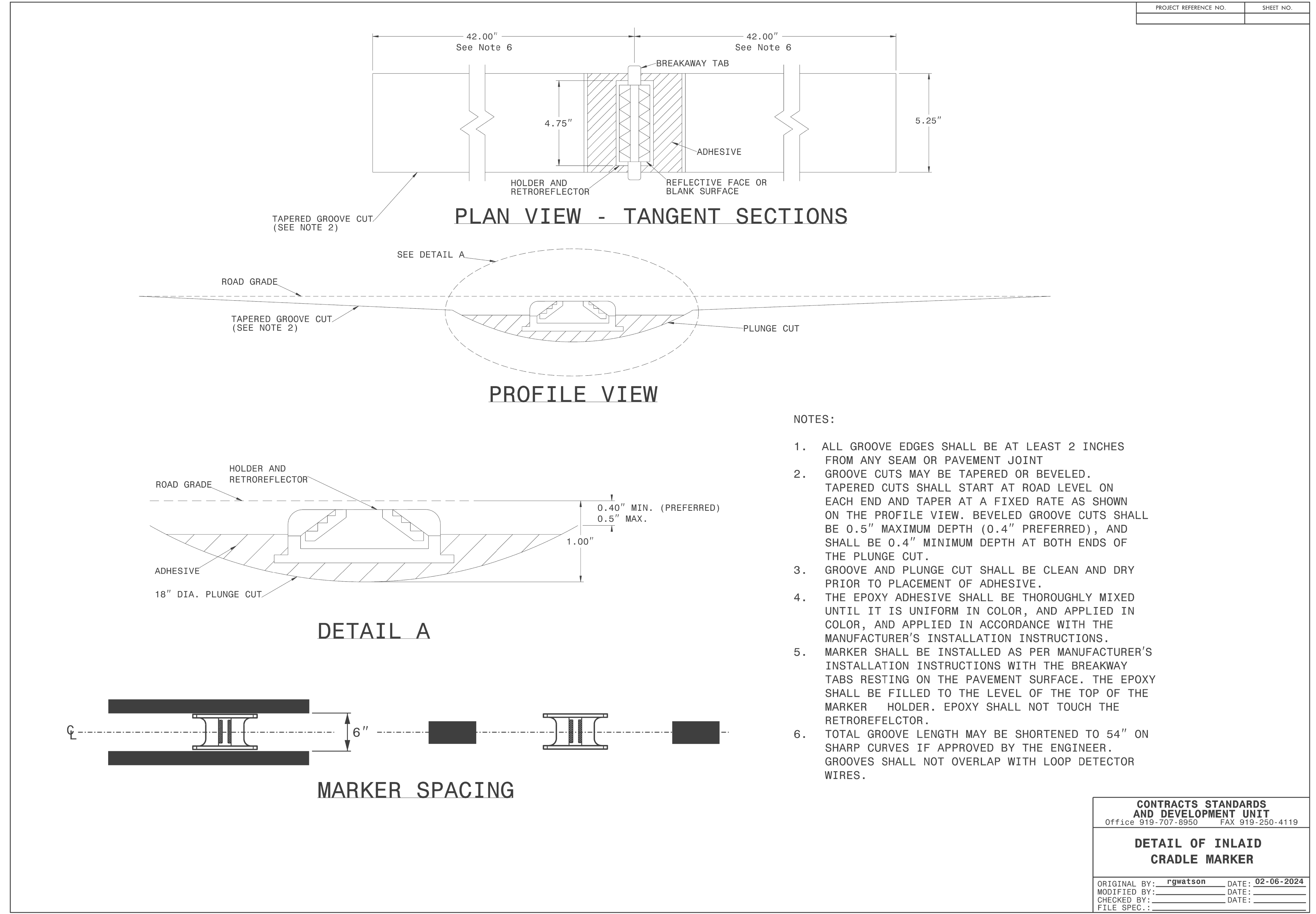

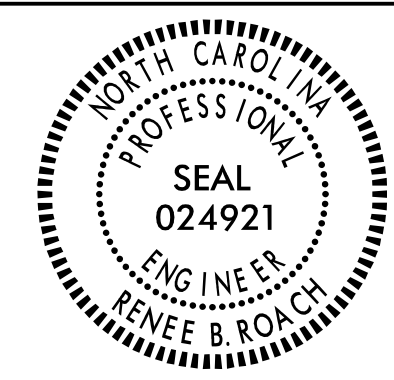

DETAIL OF INLAID CRADLE MARKER

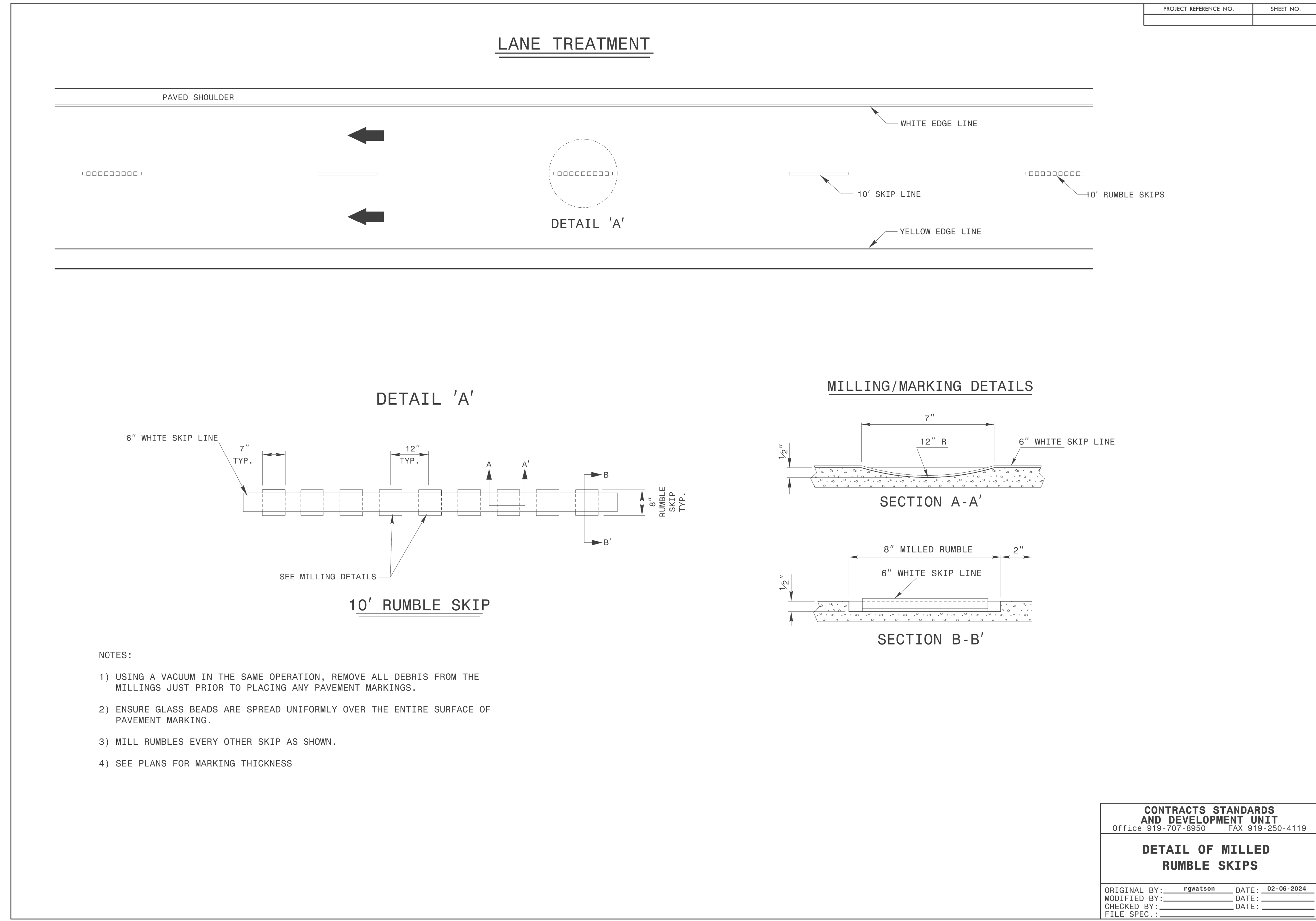
TIP NO. R-2307B & I-5717	SHEET NO. PMP-1D
APPROVED: <i>Kenee B. Roach, PE</i>	
DATE: 8/16/2024	
	
DOCUMENT NOT CONSIDERED FINAL UNLESS ALL SIGNATURES COMPLETED	

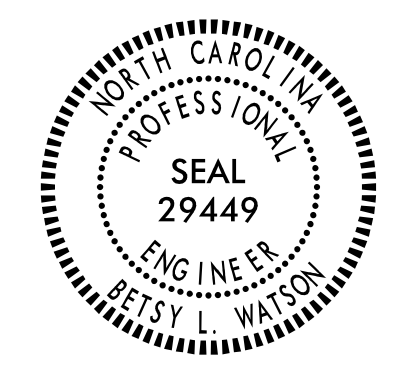

DETAIL OF MILLED RUMBLE SKIPS

TIP NO. R-2307B & I-5717	SHEET NO. PMP-2
APPROVED: <i>Betsy L. Watson</i> 35E97B83F8743F	
DATE: 8/14/2024	
SEAL	
	
DOCUMENT NOT CONSIDERED FINAL UNLESS ALL SIGNATURES COMPLETED	
	

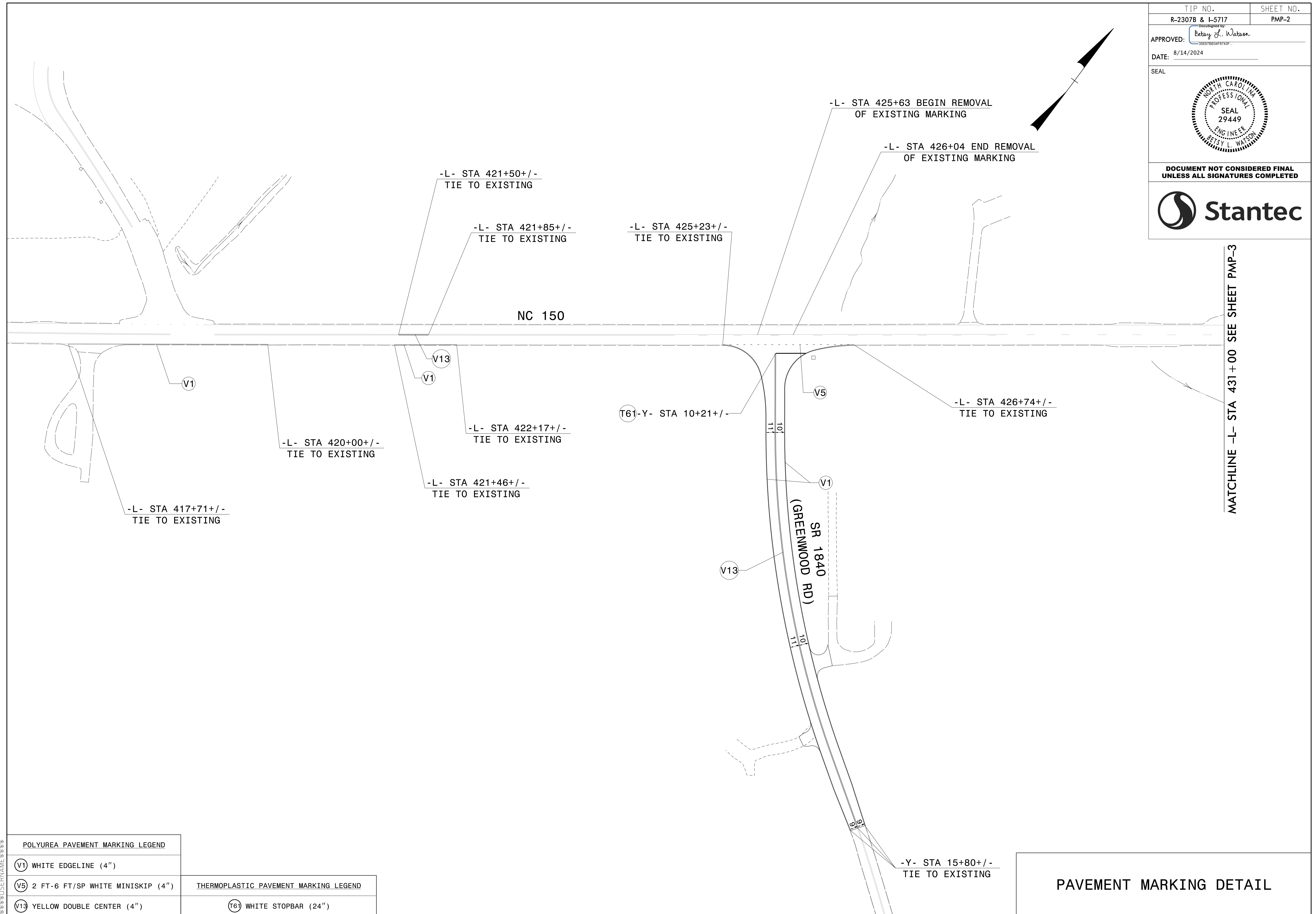
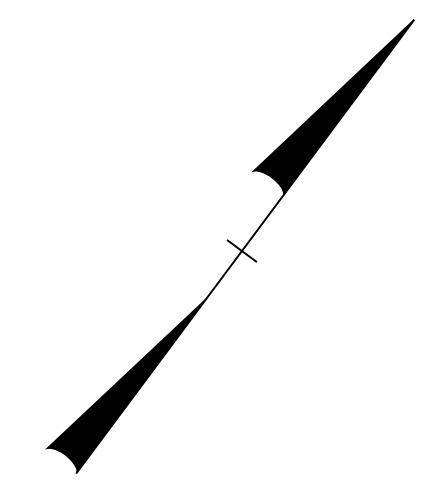

\$\$\$\$\$SYTIME\$\$\$\$\$
\$\$\$\$\$DGN\$\$\$\$\$
\$\$\$\$\$USERNAME\$\$\$\$\$



POLYUREA PAVEMENT MARKING LEGEND

(V1)	WHITE EDGELINE (4")
(V5)	2 FT-6 FT/SP WHITE MINISKIP (4")
(V13)	YELLOW DOUBLE CENTER (4")

THERMOPLASTIC PAVEMENT MARKING LEGEND

(T61)	WHITE STOPBAR (24")
-------	---------------------

PAVEMENT MARKING DETAIL

TIP NO. R-2307B & I-5717	SHEET NO. PMP-3
APPROVED: <i>Betsy L. Watson</i> <small>35E97B834F8743F</small>	
DATE: 8/14/2024	
SEAL	
	
DOCUMENT NOT CONSIDERED FINAL UNLESS ALL SIGNATURES COMPLETED	
	

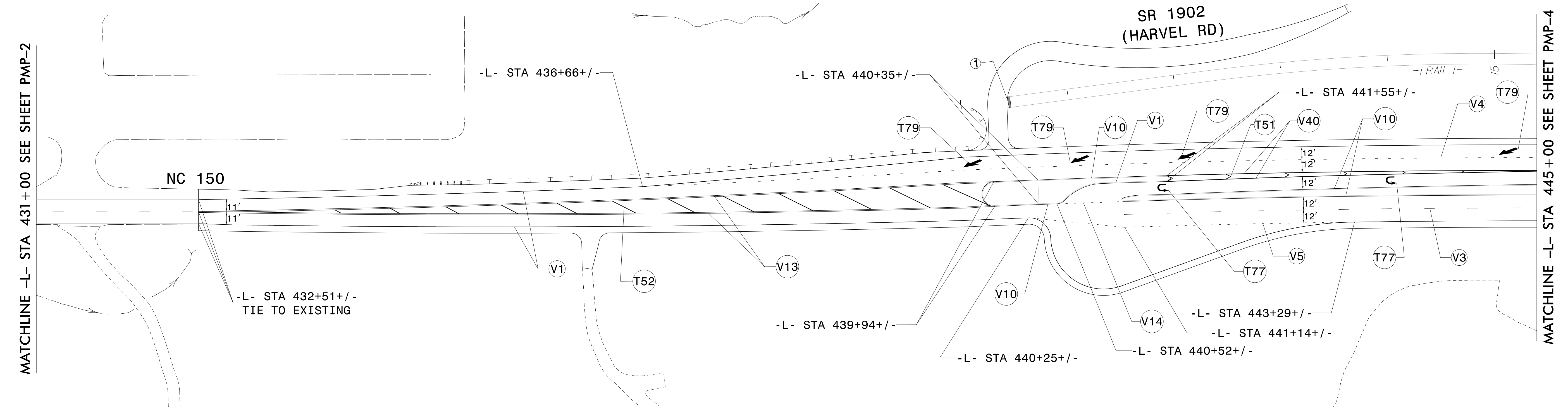
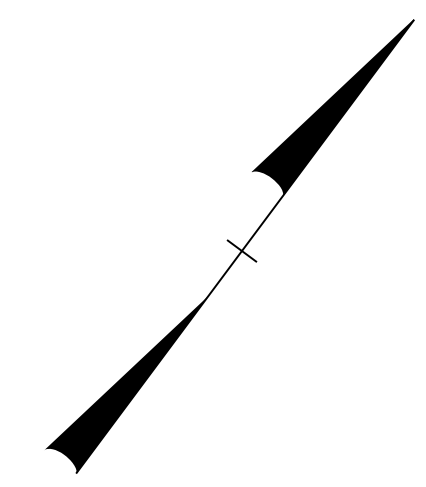

POLYUREA PAVEMENT MARKING LEGEND



V1	WHITE EDGELINE (4")
V3	10 FT WHITE SKIP (4")
V4	3 FT-9 FT/SP WHITE MINISKIP (4")
V5	2 FT-6 FT/SP WHITE MINISKIP (4")
V10	YELLOW EDGELINE (4")
V13	YELLOW DOUBLE CENTER (4")
V14	2 FT-6 FT/SP YELLOW MINISKIP (4")
V40	WHITE GORELINE (8")

THERMOPLASTIC PAVEMENT MARKING LEGEND

T52	WHITE DIAGONAL (12")	T77	U-TURN ARROW
T79	YELLOW DIAGONAL (12")	T79	MERGE ARROW

	CURB RAMP STATIONS	CURB RAMP TYPE
1	-TRAIL1- STA 10+44+/-	DETECTABLE WARNING SURFACE

PAVEMENT MARKING DETAIL

TIP NO. R-2307B & I-5717	SHEET NO. PMP-4
APPROVED: <i>Betsy L. Watson</i> <small>35E67B83F8743F</small>	
DATE: 8/14/2024	
SEAL	
	
DOCUMENT NOT CONSIDERED FINAL UNLESS ALL SIGNATURES COMPLETED	
	

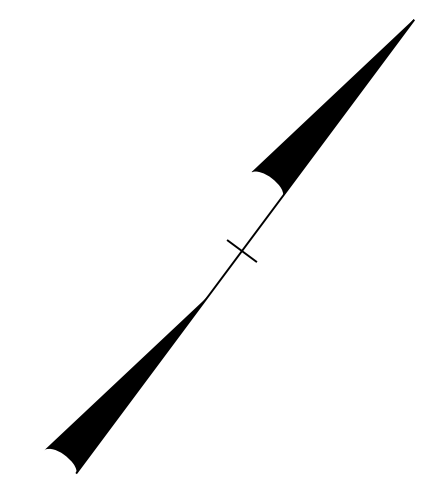

MATCHLINE -L- STA 445 + 00 SEE SHEET PMP-3

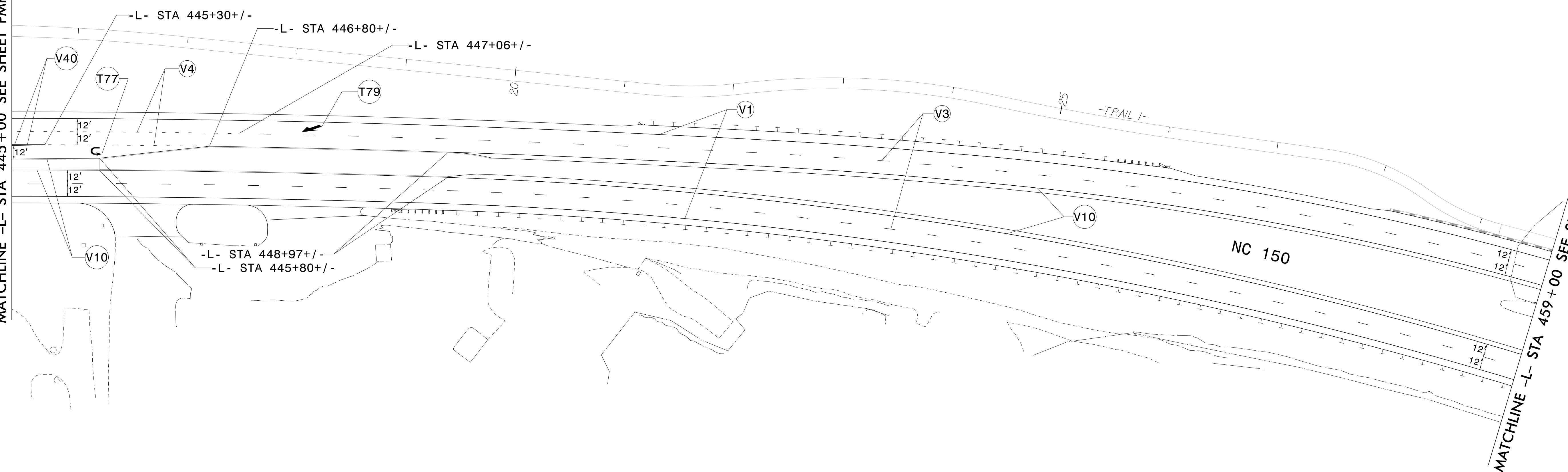



MATCHLINE -L- STA 459 + 00 SEE SHEET PMP-5

\$\$\$\$\$SYTIME\$\$\$\$\$
\$\$\$\$\$DGN\$\$\$\$\$
\$\$\$\$\$USERNAME\$\$\$\$\$

POLYUREA PAVEMENT MARKING LEGEND	
(V1)	WHITE EDGELINE (4")
(V3)	10 FT WHITE SKIP (4")
(V4)	3 FT-9 FT/SP WHITE MINISKIP (4")
(V10)	YELLOW EDGELINE (4")
(V40)	WHITE GORELINE (8")

THERMOPLASTIC PAVEMENT MARKING LEGEND	
(T77)	U-TURN ARROW
(T79)	MERGE ARROW

PAVEMENT MARKING DETAIL

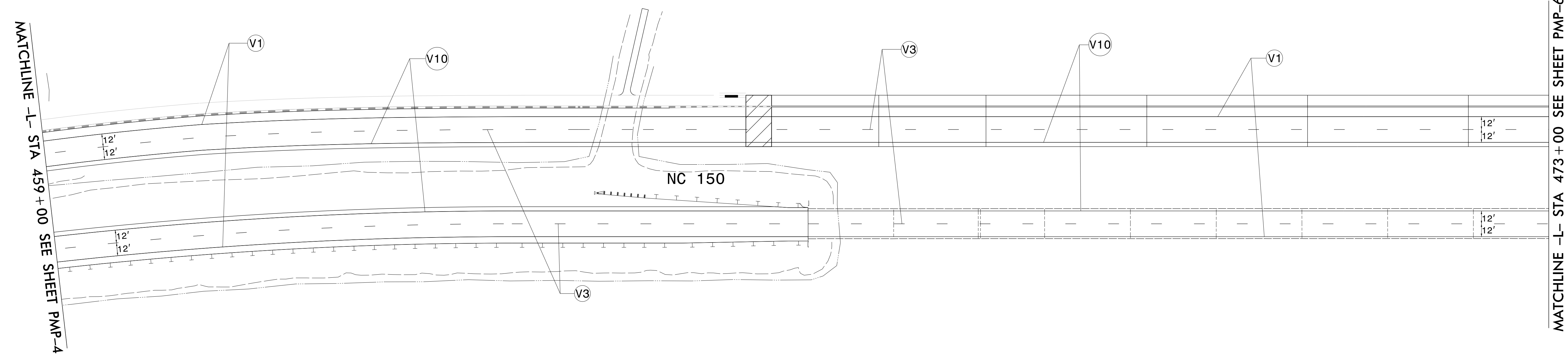
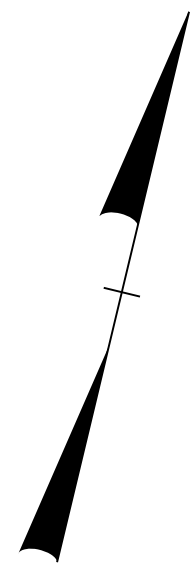

TIP NO. R-2307B & I-5717	SHEET NO. PMP-5
APPROVED: <i>Betsy L. Watson</i> <small>35E97B834F8743F</small>	
DATE: 8/14/2024	
SEAL	
	
DOCUMENT NOT CONSIDERED FINAL UNLESS ALL SIGNATURES COMPLETED	
	



\$\$\$\$\$SYTIME\$\$\$\$\$
\$\$\$\$\$DGN\$\$\$\$\$
\$\$\$\$\$USERNAME\$\$\$\$\$

POLYUREA PAVEMENT MARKING LEGEND	
(V1)	WHITE EDGELINE (4")
(V3)	10 FT WHITE SKIP (4")
(V10)	YELLOW EDGELINE (4")

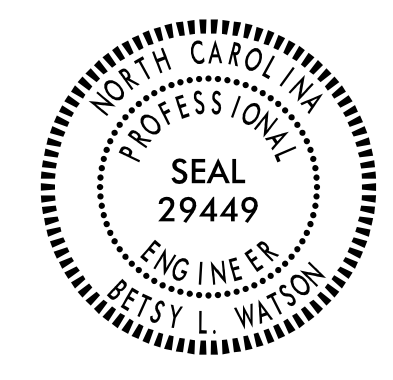
PAVEMENT MARKING DETAIL

TIP NO. R-2307B & I-5717	SHEET NO. PMP-6
APPROVED: <i>Betsy L. Watson</i> <small>35E97B34F8743F</small>	
DATE: 8/14/2024	
SEAL	
	
DOCUMENT NOT CONSIDERED FINAL UNLESS ALL SIGNATURES COMPLETED	
	

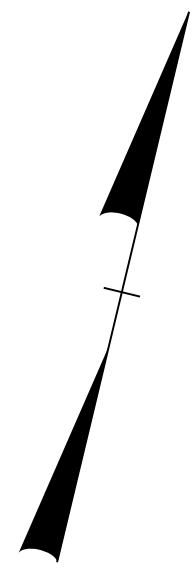

MATCHLINE -L- STA 473 + 00 SEE SHEET PMP-5

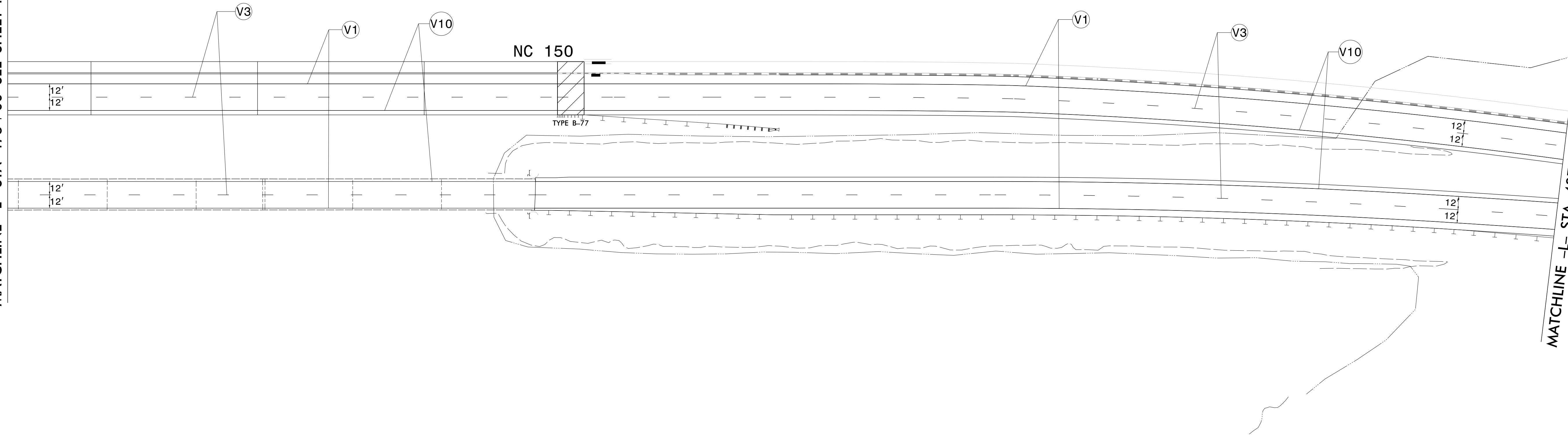



MATCHLINE -L- STA 487 + 00 SEE SHEET PMP-7

\$\$\$\$\$SYTIME\$\$\$\$\$
\$\$\$\$\$DGN\$\$\$\$\$
\$\$\$\$\$USERNAME\$\$\$\$\$

POLYUREA PAVEMENT MARKING LEGEND	
(V1)	WHITE EDGELINE (4")
(V3)	10 FT WHITE SKIP (4")
(V10)	YELLOW EDGELINE (4")

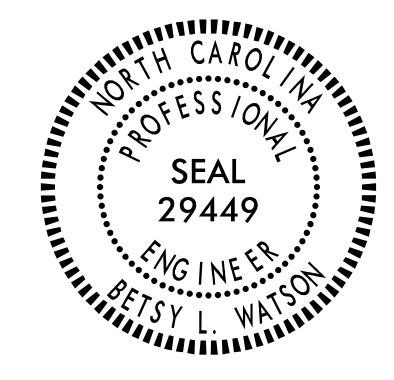
PAVEMENT MARKING DETAIL

TIP NO. R-2307B & I-5717	SHEET NO. PMP-7
APPROVED: <i>Betsy L. Watson</i> SEAL 29449 ENGINEER BETSY L. WATSON	
DATE: 8/14/2024	
SEAL	
	
DOCUMENT NOT CONSIDERED FINAL UNLESS ALL SIGNATURES COMPLETED	
	

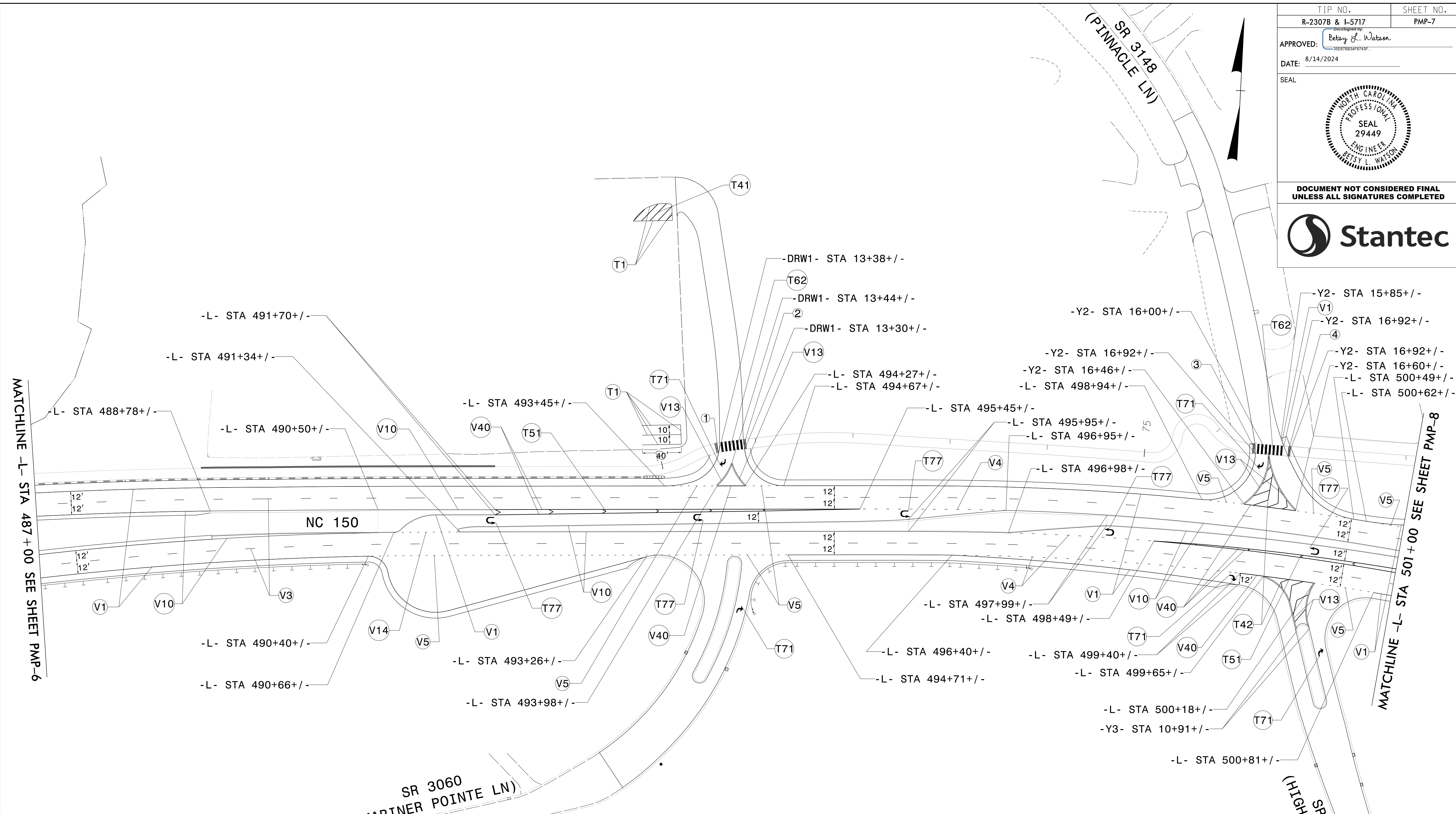

POLYUREA PAVEMENT MARKING LEGEND	
V1	WHITE EDGELINE (4")
V3	10 FT WHITE SKIP (4")
V4	3 FT-9 FT/SP WHITE MINISKIP (4")
V5	2 FT-6 FT/SP WHITE MINISKIP (4")
V10	YELLOW EDGELINE (4")
V13	YELLOW DOUBLE CENTER (4")
V14	2 FT-6 FT/SP YELLOW MINISKIP (4")
V40	WHITE GORELINE (8")

THERMOPLASTIC PAVEMENT MARKING LEGEND	
T1	WHITE EDGELINE (4")
T41	WHITE DIAGONAL (8")
T42	YELLOW DIAGONAL (8")
T51	WHITE DIAGONAL (12")
T62	WHITE CROSSWALK LINE (24")
T71	RIGHT TURN ARROW
T77	U-TURN ARROW

	CURB RAMP STATIONS	CURB RAMP TYPE
1	-TRAIL2- STA 70+60+/-	DETECTABLE WARNING SURFACE
2	-TRAIL2- STA 70+88+/-	DETECTABLE WARNING SURFACE
3	-TRAIL2- STA 76+44+/-	DETECTABLE WARNING SURFACE
4	-TRAIL2- STA 76+79+/-	DETECTABLE WARNING SURFACE

PAVEMENT MARKING DETAIL

\$\$\$SYTIME\$\$\$\$\$
 \$\$\$DGN\$\$\$\$\$
 \$\$\$USERNAME\$\$\$\$\$

TIP NO. R-2307B & I-5717	SHEET NO. PMP-8
APPROVED: <i>Betsy L. Watson</i> <small>REGISTERED PROFESSIONAL ENGINEER</small>	
DATE: 8/14/2024	
SEAL	
DOCUMENT NOT CONSIDERED FINAL UNLESS ALL SIGNATURES COMPLETED	

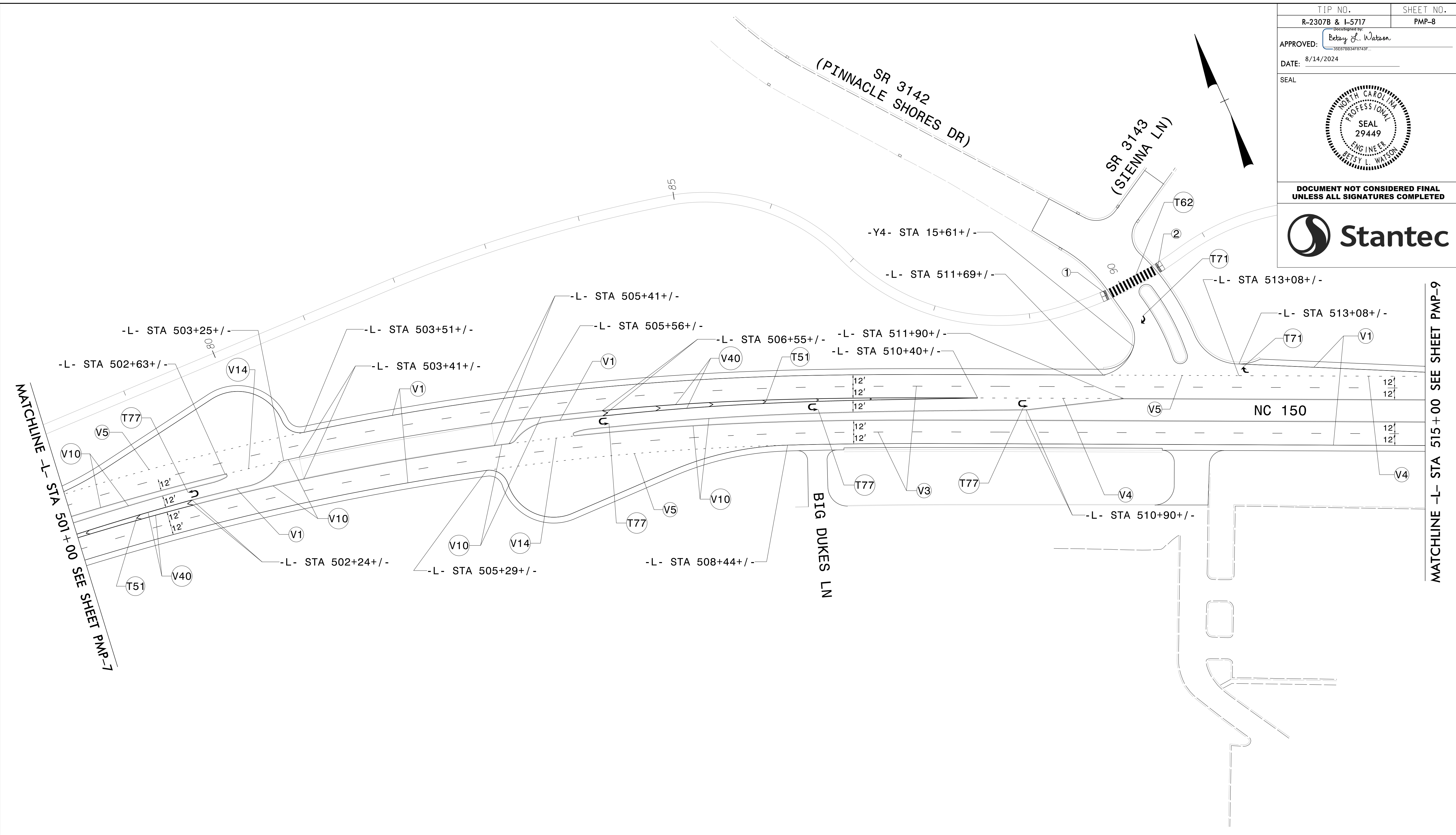

POLYUREA PAVEMENT MARKING LEGEND	
(V1)	WHITE EDGELINE (4")
(V3)	10 FT WHITE SKIP (4")
(V4)	3 FT-9 FT/SP WHITE MINISKIP (4")
(V5)	2 FT-6 FT/SP WHITE MINISKIP (4")
(V10)	YELLOW EDGELINE (4")
(V14)	2 FT-6 FT/SP YELLOW MINISKIP (4")
(V40)	WHITE GORELINE (8")

THERMOPLASTIC PAVEMENT MARKING LEGEND	
(T51)	WHITE DIAGONAL (12")
(T62)	WHITE CROSSWALK LINE (24")
(T71)	RIGHT TURN ARROW
(T77)	U-TURN ARROW

	CURB RAMP STATIONS	CURB RAMP TYPE
①	-TRAIL2- STA 89+83+/-	TYPE 1 MODIFIED
②	-TRAIL2- STA 90+42+/-	TYPE 1 MODIFIED

PAVEMENT MARKING DETAIL

\$\$\$SYTIME\$\$\$\$\$
 \$\$\$DGN\$\$\$\$\$
 \$\$\$USERNAME\$\$\$\$\$

TIP NO. R-2307B & I-5717	SHEET NO. PMP-9
APPROVED: <i>Betsy L. Watson</i> <small>35E97B83F8743F</small>	
DATE: 8/14/2024	
SEAL	
DOCUMENT NOT CONSIDERED FINAL UNLESS ALL SIGNATURES COMPLETED	

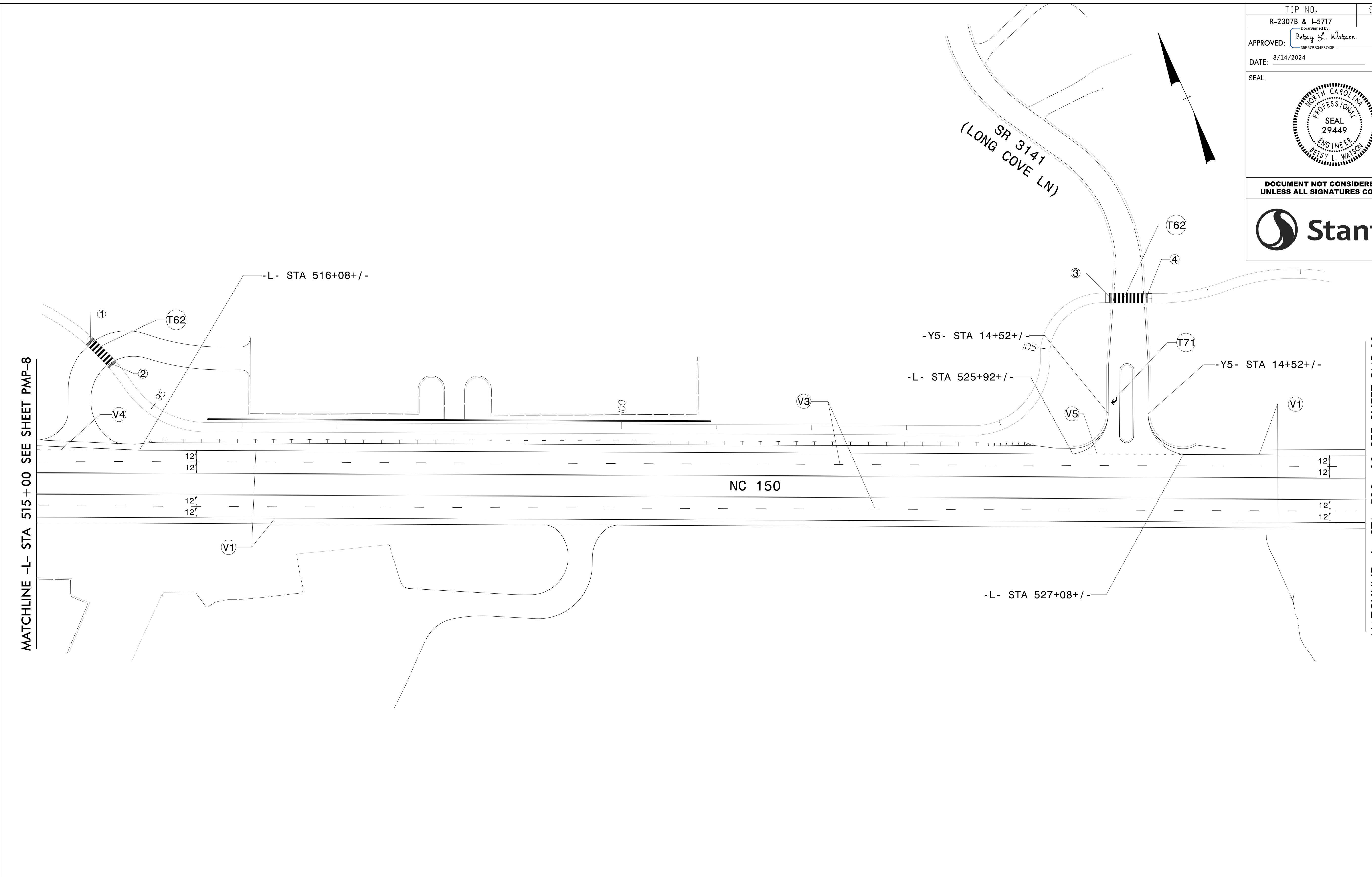



POLYUREA PAVEMENT MARKING LEGEND	
V1	WHITE EDGELINE (4")
V3	10 FT WHITE SKIP (4")
V4	3 FT-9 FT/SP WHITE MINISKIP (4")
V5	2 FT-6 FT/SP WHITE MINISKIP (4")

THERMOPLASTIC PAVEMENT MARKING LEGEND	
T62	WHITE CROSSWALK LINE (24")
T71	RIGHT TURN ARROW

	CURB RAMP STATIONS	CURB RAMP TYPE
1	-TRAIL2- STA 94+05+/-	DETECTABLE WARNING SURFACE
2	-TRAIL2- STA 94+36+/-	DETECTABLE WARNING SURFACE
3	-TRAIL2- STA 105+97+/-	TYPE 1 MODIFIED
4	-TRAIL2- STA 106+34+/-	TYPE 1 MODIFIED

PAVEMENT MARKING DETAIL

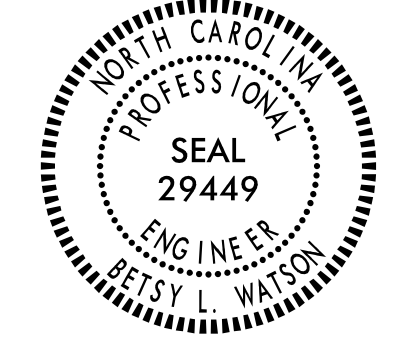
\$\$\$\$\$SYTIME\$\$\$\$\$
\$\$\$\$\$DGN\$\$\$\$\$
\$\$\$\$\$USERNAME\$\$\$\$\$

TIP NO. R-2307B & I-5717	SHEET NO. PMP-10
APPROVED: <i>Betsy L. Watson</i> 35E97B34F8743F	
DATE: 8/14/2024	
SEAL	
	
DOCUMENT NOT CONSIDERED FINAL UNLESS ALL SIGNATURES COMPLETED	
	

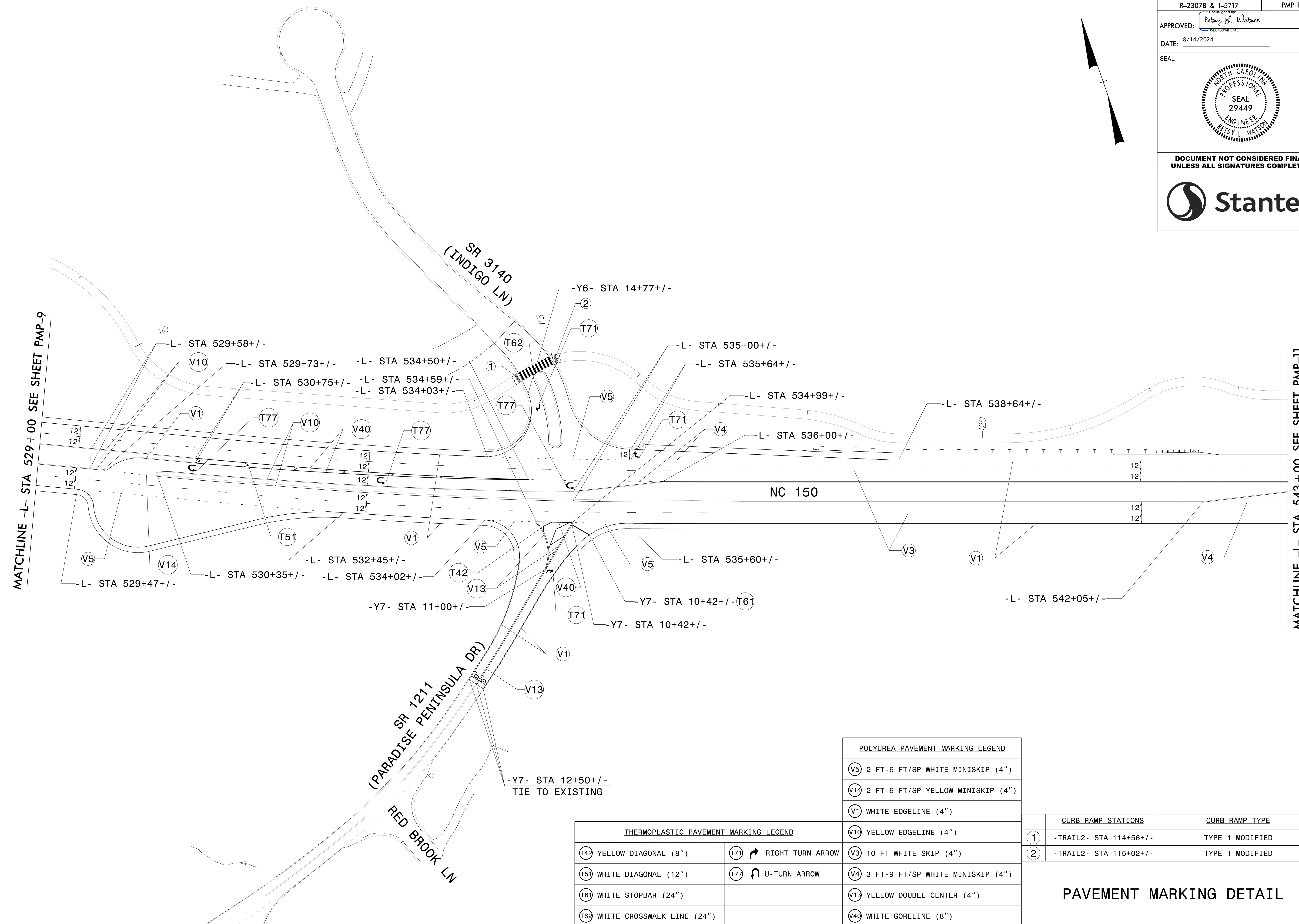
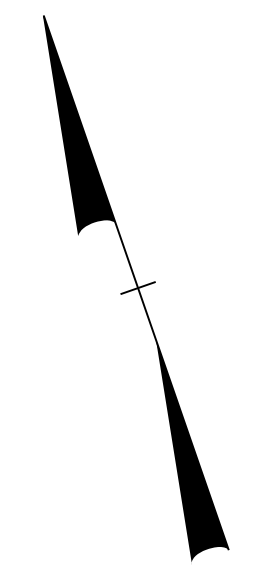

\$\$\$\$\$SYTIME\$\$\$\$\$
 \$\$\$\$DDGN\$\$\$\$\$
 \$\$\$\$.USERNAME\$\$\$\$\$

THERMOPLASTIC PAVEMENT MARKING LEGEND		POLYUREA PAVEMENT MARKING LEGEND	
(T42) YELLOW DIAGONAL (8")	(T71) RIGHT TURN ARROW	(V5) 2 FT-6 FT/SP WHITE MINISKIP (4")	(V3) 10 FT WHITE SKIP (4")
(T51) WHITE DIAGONAL (12")	(T77) U-TURN ARROW	(V14) 2 FT-6 FT/SP YELLOW MINISKIP (4")	(V4) 3 FT-9 FT/SP WHITE MINISKIP (4")
(T61) WHITE STOPBAR (24")		(V1) WHITE EDGELINE (4")	(V13) YELLOW DOUBLE CENTER (4")
(T62) WHITE CROSSWALK LINE (24")		(V10) YELLOW EDGELINE (4")	(V40) WHITE GORELINE (8")

	CURB RAMP STATIONS	CURB RAMP TYPE
①	-TRAIL2- STA 114+56+/-	TYPE 1 MODIFIED
②	-TRAIL2- STA 115+02+/-	TYPE 1 MODIFIED

PAVEMENT MARKING DETAIL

TIP NO. R-2307B & I-5717	SHEET NO. PMP-11
APPROVED: <i>Betsy L. Watson</i> SEAL 29449	
DATE: 8/14/2024	
SEAL	
DOCUMENT NOT CONSIDERED FINAL UNLESS ALL SIGNATURES COMPLETED	

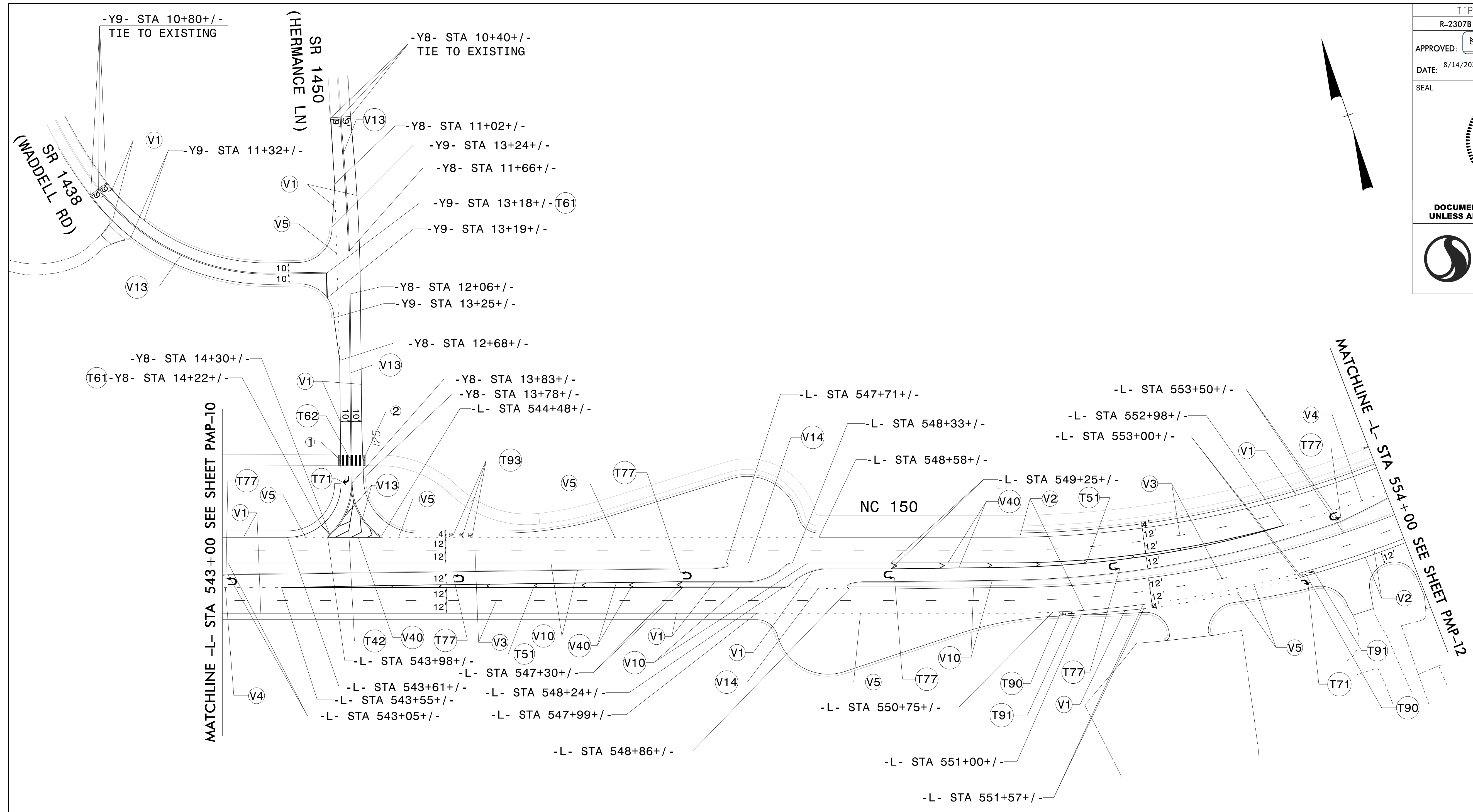
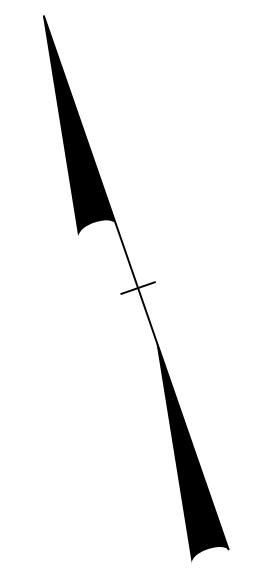

POLYUREA PAVEMENT MARKING LEGEND

V1	WHITE EDGELINE (4")
V2	WHITE SOLID LANE LINE (4")
V3	10 FT WHITE SKIP (4")
V4	3 FT-9 FT/SP WHITE MINISKIP (4")
V5	2 FT-6 FT/SP WHITE MINISKIP (4")
V10	YELLOW EDGELINE (4")
V13	YELLOW DOUBLE CENTER (4")
V14	2 FT-6 FT/SP YELLOW MINISKIP (4")
V40	WHITE GORELINE (8")

THERMOPLASTIC PAVEMENT MARKING LEGEND

T42	YELLOW DIAGONAL (8")	T71	RIGHT TURN ARROW
T51	WHITE DIAGONAL (12")	T77	U-TURN ARROW
T62	WHITE STOPBAR (24")	T90	BICYCLE SYMBOL
T62	WHITE CROSSWALK LINE (24")	T91	BICYCLE STRAIGHT ARROW
T93	LANE BICYCLE CHARACTER	T99	ENDS BICYCLE CHARACTER

	CURB RAMP STATIONS	CURB RAMP TYPE
1	-TRAIL2- STA 124+67+/-	DETECTABLE WARNING SURFACE
2	-TRAIL2- STA 124+88+/-	DETECTABLE WARNING SURFACE

PAVEMENT MARKING DETAIL

\$\$\$\$\$SYTIME\$\$\$\$\$
\$\$\$\$\$DGN\$\$\$\$\$
\$\$\$\$\$USERNAME\$\$\$\$\$

TIP NO. R-2307B & I-5717	SHEET NO. PMP-12
APPROVED: <i>Betsy L. Watson</i> <small>35E97B34F8743F</small>	
DATE: 8/14/2024	
SEAL	
DOCUMENT NOT CONSIDERED FINAL UNLESS ALL SIGNATURES COMPLETED	

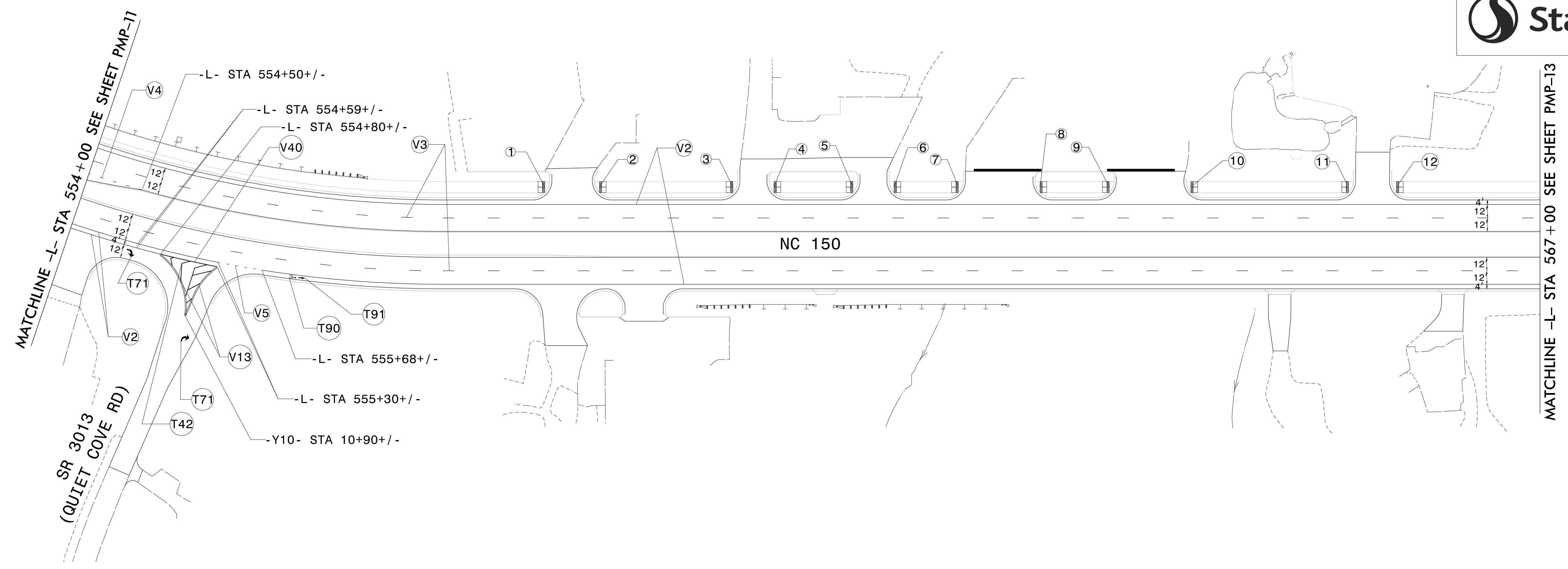
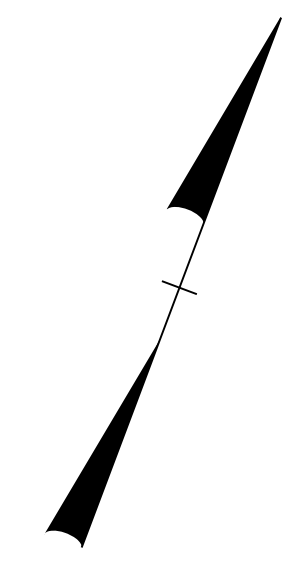



\$\$\$SYTIME\$\$\$
 \$\$\$DGN\$\$\$
 \$\$\$USERNAME\$\$\$

POLYUREA PAVEMENT MARKING LEGEND	THERMOPLASTIC PAVEMENT MARKING LEGEND
(V2) WHITE SOLID LANE LINE (4")	(T42) YELLOW DIAGONAL (8")
(V3) 10 FT WHITE SKIP (4")	(T71) RIGHT TURN ARROW
(V4) 3 FT-9 FT/SP WHITE MINISKIP (4")	(T90) BICYCLE SYMBOL
(V5) 2 FT-6 FT/SP WHITE MINISKIP (4")	(T91) BICYCLE STRAIGHT ARROW

	CURB RAMP STATIONS	CURB RAMP TYPE
(1)	-L- STA 558+18+/-	TYPE 1 MODIFIED
(2)	-L- STA 558+63+/-	TYPE 1 MODIFIED
(3)	-L- STA 559+82+/-	TYPE 1 MODIFIED
(4)	-L- STA 560+19+/-	TYPE 1 MODIFIED
(5)	-L- STA 560+89+/-	TYPE 1 MODIFIED
(6)	-L- STA 561+25+/-	TYPE 1 MODIFIED
(7)	-L- STA 561+83+/-	TYPE 1 MODIFIED
(8)	-L- STA 562+55+/-	TYPE 1 MODIFIED
(9)	-L- STA 563+17+/-	TYPE 1 MODIFIED
(10)	-L- STA 563+89+/-	TYPE 1 MODIFIED
(11)	-L- STA 565+30+/-	TYPE 1 MODIFIED
(12)	-L- STA 565+72+/-	TYPE 1 MODIFIED

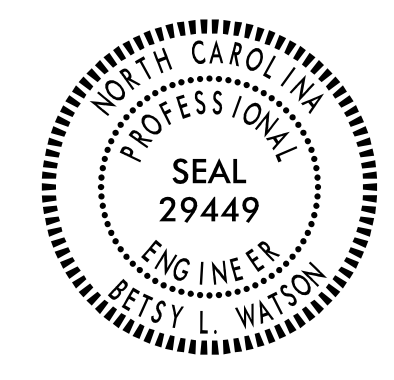
PAVEMENT MARKING DETAIL

TIP NO. R-2307B & I-5717	SHEET NO. PMP-13
APPROVED: <i>Betsy L. Watson</i> 35E97B34F8743F	
DATE: 8/14/2024	
SEAL	
	
DOCUMENT NOT CONSIDERED FINAL UNLESS ALL SIGNATURES COMPLETED	
	

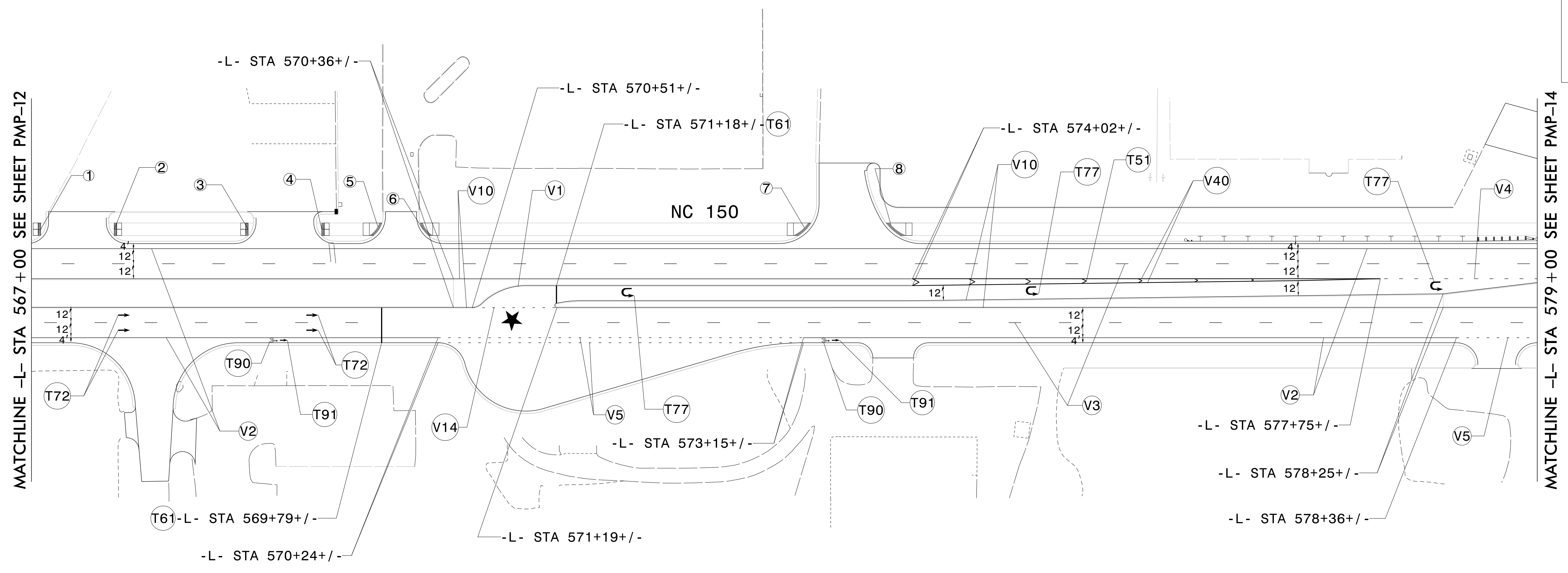
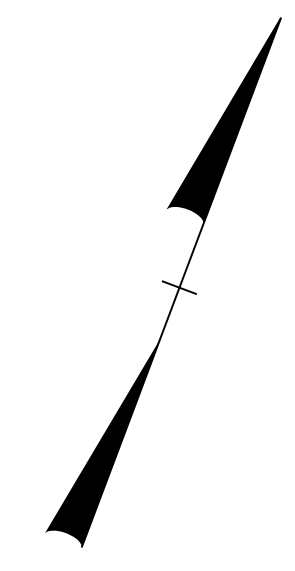



★ PROPOSED SIGNAL

THERMOPLASTIC PAVEMENT MARKING LEGEND	
T51	WHITE DIAGONAL (12")
T61	WHITE STOPBAR (24")
T72	↑ STRAIGHT ARROW
T77	↪ U-TURN ARROW
T90	🚲 BICYCLE SYMBOL
T91	↑ BICYCLE STRAIGHT ARROW

	CURB RAMP STATIONS	CURB RAMP TYPE
1	-L- STA 567+07+/-	TYPE 1 MODIFIED
2	-L- STA 567+65+/-	TYPE 1 MODIFIED
3	-L- STA 568+73+/-	TYPE 1 MODIFIED
4	-L- STA 569+31+/-	TYPE 1 MODIFIED
5	-L- STA 569+77+/-	TYPE 1C
6	-L- STA 570+12+/-	TYPE 1C
7	-L- STA 573+17+/-	TYPE 1C
8	-L- STA 573+86+/-	TYPE 1C

PAVEMENT MARKING DETAIL

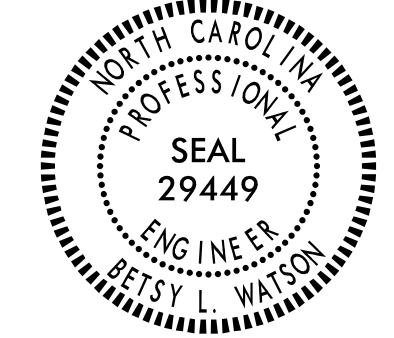
\$\$\$\$\$SYTIME\$\$\$\$\$
\$\$\$\$\$DGN\$\$\$\$\$
\$\$\$\$\$USERNAME\$\$\$\$\$

TIP NO. R-2307B & I-5717	SHEET NO. PMP-14
APPROVED: <i>Betsy L. Watson</i> 35E97B34F8743F	
DATE: 8/14/2024	
SEAL	
	
DOCUMENT NOT CONSIDERED FINAL UNLESS ALL SIGNATURES COMPLETED	
	

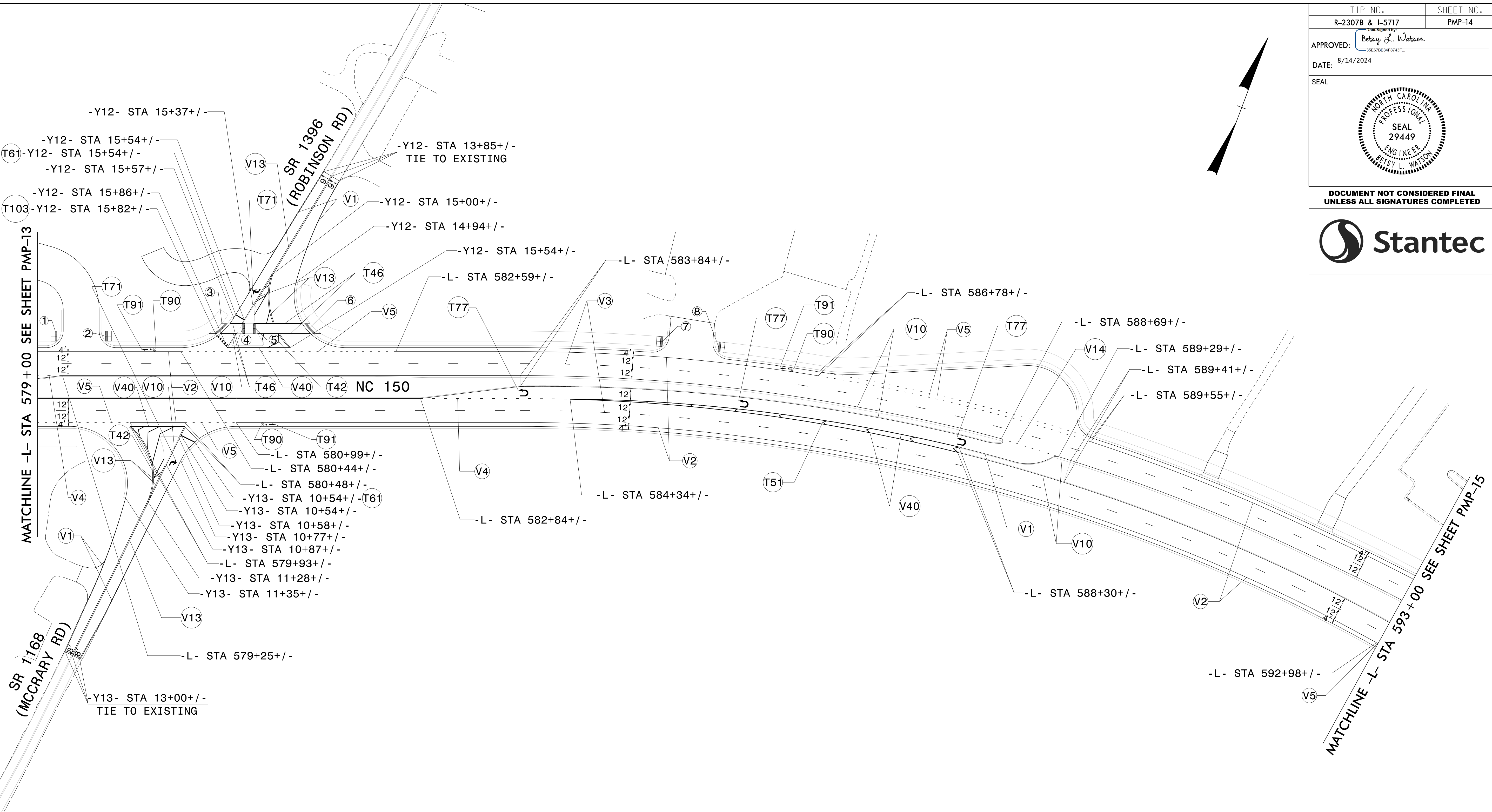
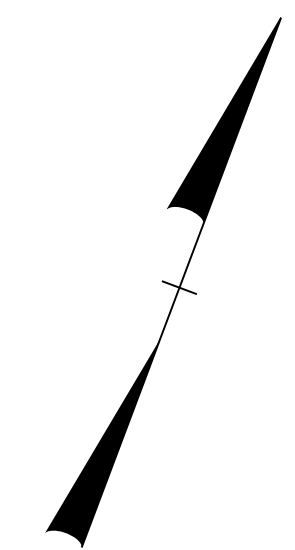

POLYUREA PAVEMENT MARKING LEGEND	
(V1)	WHITE EDGELINE (4")
(V2)	WHITE SOLID LANE LINE (4")
(V3)	10 FT WHITE SKIP (4")
(V4)	3 FT-9 FT/SP WHITE MINISKIP (4")
(V5)	2 FT-6 FT/SP WHITE MINISKIP (4")
(V10)	YELLOW EDGELINE (4")
(V13)	YELLOW DOUBLE CENTER (4")
(V14)	2 FT-6 FT/SP YELLOW MINISKIP (4")
(V40)	WHITE GORELINE (8")

THERMOPLASTIC PAVEMENT MARKING LEGEND	
(T42)	YELLOW DIAGONAL (8")
(T46)	WHITE CROSSWALK LINE (8")
(T51)	WHITE DIAGONAL (12")
(T61)	WHITE STOPBAR (24")
(T71)	RIGHT TURN ARROW
(T77)	U-TURN ARROW
(T90)	BICYCLE SYMBOL
(T91)	BICYCLE STRAIGHT ARROW
(T103)	24" YIELD LINE TRIANGLE

	CURB RAMP STATIONS	CURB RAMP TYPE
(1)	-L- STA 579+20+/-	TYPE 1 MODIFIED
(2)	-L- STA 579+68+/-	TYPE 1 MODIFIED
(3)	-Y12- STA 15+73+/-	TYPE 1D
(4)	-Y12- STA 15+62+/-	TYPE 7
(5)	-Y12- STA 15+55+/-	TYPE 7
(6)	-Y12- STA 15+28+/-	TYPE 1D
(7)	-L- STA 585+23+/-	TYPE 1 MODIFIED
(8)	-L- STA 585+78+/-	TYPE 1 MODIFIED

\$\$\$SYTIME\$\$\$\$
 \$\$\$DGN\$\$\$\$
 \$\$\$USERNAME\$\$\$\$

PAVEMENT MARKING DETAIL

TIP NO. R-2307B & I-5717	SHEET NO. PMP-15
APPROVED: <i>Betsy L. Watson</i> <small>REGISTERED PROFESSIONAL ENGINEER</small>	
DATE: 8/14/2024	
SEAL	
DOCUMENT NOT CONSIDERED FINAL UNLESS ALL SIGNATURES COMPLETED	

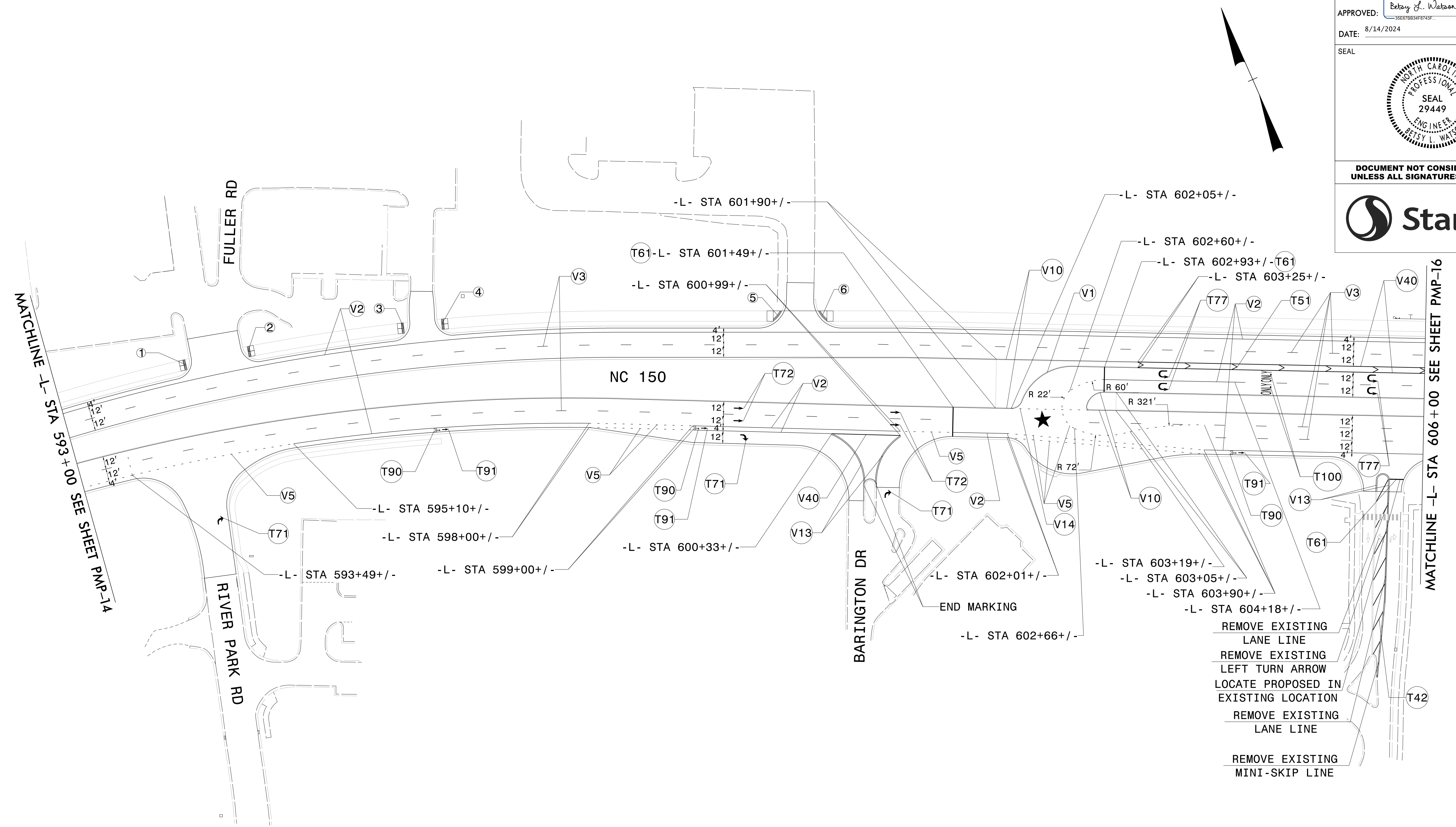

- REMOVE EXISTING LANE LINE
- REMOVE EXISTING LEFT TURN ARROW
- LOCATE PROPOSED IN EXISTING LOCATION
- REMOVE EXISTING LANE LINE
- REMOVE EXISTING MINI-SKIP LINE

POLYUREA PAVEMENT MARKING LEGEND

V1	WHITE EDGELINE (4")
V2	WHITE SOLID LANE LINE (4")
V3	10 FT WHITE SKIP (4")
V5	2 FT-6 FT/SP WHITE MINISKIP (4")
V10	YELLOW EDGELINE (4")
V13	YELLOW DOUBLE CENTER (4")
V14	2 FT-6 FT/SP YELLOW MINISKIP (4")
V40	WHITE GORELINE (8")

★ PROPOSED SIGNAL



THERMOPLASTIC PAVEMENT MARKING LEGEND

T42	YELLOW DIAGONAL (8")	T90	BICYCLE SYMBOL
T5	WHITE DIAGONAL (12")	T91	BICYCLE STRAIGHT ARROW
T6	WHITE STOPBAR (24")	T100	ONLY ALPHANUMERIC CHARACTERS
T7	RIGHT TURN ARROW		
T72	STRAIGHT ARROW		
T77	U-TURN ARROW		

	CURB RAMP STATIONS	CURB RAMP TYPE
1	-L- STA 594+22+/-	TYPE 1 MODIFIED
2	-L- STA 594+81+/-	TYPE 1 MODIFIED
3	-L- STA 596+28+/-	TYPE 1 MODIFIED
4	-L- STA 596+63+/-	TYPE 1 MODIFIED
5	-L- STA 599+80+/-	TYPE 1C
6	-L- STA 600+22+/-	TYPE 1C

\$\$\$\$\$SYTIME\$\$\$\$\$
\$\$\$\$\$DGN\$\$\$\$\$
\$\$\$\$\$USERNAME\$\$\$\$\$

PAVEMENT MARKING DETAIL

TIP NO. R-2307B & I-5717	SHEET NO. PMP-16
APPROVED: <i>Betsy L. Watson</i> <small>35E97B34F8743F</small>	
DATE: 8/14/2024	
SEAL	
	
DOCUMENT NOT CONSIDERED FINAL UNLESS ALL SIGNATURES COMPLETED	
	

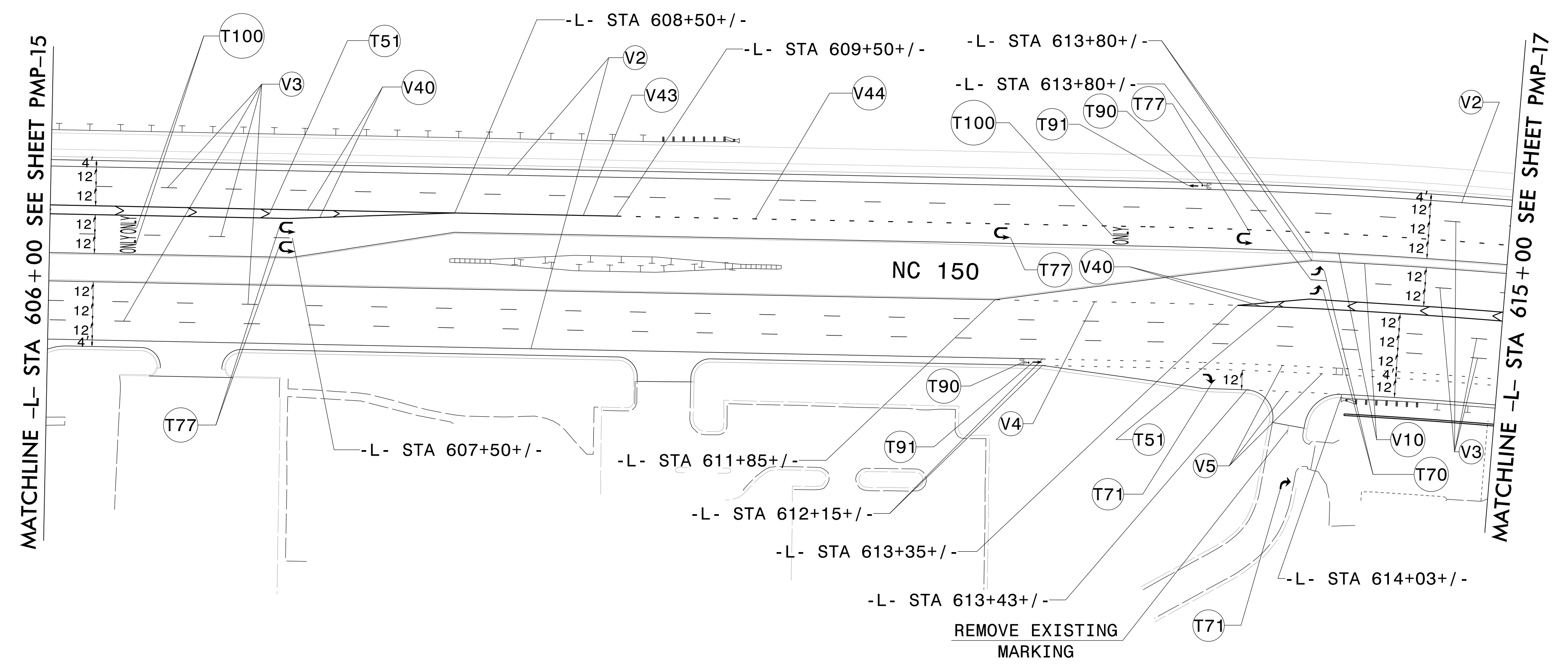
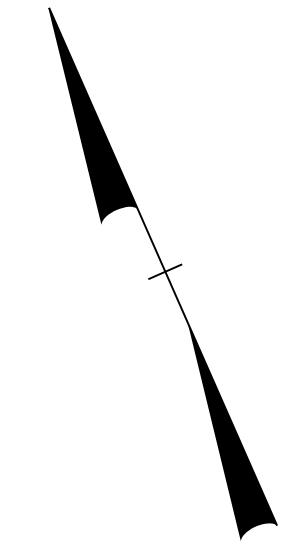

POLYUREA PAVEMENT MARKING LEGEND



(V1)	WHITE EDGELINE (4")
(V2)	WHITE SOLID LANE LINE (4")
(V3)	10 FT WHITE SKIP (4")
(V4)	3 FT-9 FT/SP WHITE MINISKIP (4")
(V5)	2 FT-6 FT/SP WHITE MINISKIP (4")
(V10)	YELLOW EDGELINE (4")
(V13)	YELLOW DOUBLE CENTER (4")
(V40)	WHITE GORELINE (8")
(V43)	WHITE SOLID LANE LINE (8")
(V44)	3 FT-9 FT/SP WHITE MINISKIP (8")

THERMOPLASTIC PAVEMENT MARKING LEGEND

(T5)	WHITE DIAGONAL (12")	(T91)	↑ BICYCLE STRAIGHT ARROW
(T6)	WHITE STOPBAR (24")	(T100)	ONLY ALPHANUMERIC CHARACTERS
(T70)	← LEFT TURN ARROW		
(T71)	↘ RIGHT TURN ARROW		
(T77)	↻ U-TURN ARROW		
(T90)	⚡ BICYCLE SYMBOL		

\$\$\$\$\$SYTIME\$\$\$\$\$
\$\$\$\$\$DGN\$\$\$\$\$
\$\$\$\$\$USERNAM\$\$\$\$\$

PAVEMENT MARKING DETAIL

TIP NO. R-2307B & I-5717	SHEET NO. PMP-17
APPROVED: <i>Betsy L. Watson</i> SEAL 29449	
DATE: 8/14/2024	
SEAL	
	
DOCUMENT NOT CONSIDERED FINAL UNLESS ALL SIGNATURES COMPLETED	
	

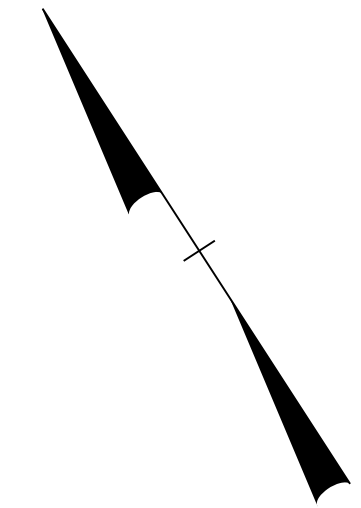

	CURB RAMP STATIONS	CURB RAMP TYPE
1	-Y16- STA 24+73+/-	TYPE 1D
2	-Y16- STA 24+95+/-	TYPE 7
3	-Y16- STA 24+94+/-	TYPE 7
4	-Y16- STA 24+95+/-	STANDARD
5	-L- STA 619+25+/-	STANDARD
6	-L- STA 618+68+/-	TYPE 7
7	-L- STA 618+14+/-	TYPE 7
8	-L- STA 617+90+/-	TYPE 3 MODIFIED
9	-Y17- STA 11+87+/-	TYPE 1 MODIFIED
10	-Y17- STA 12+27+/-	TYPE 1 MODIFIED
11	-Y17- STA 13+41+/-	TYPE 1 MODIFIED
12	-Y17- STA 13+77+/-	TYPE 1 MODIFIED

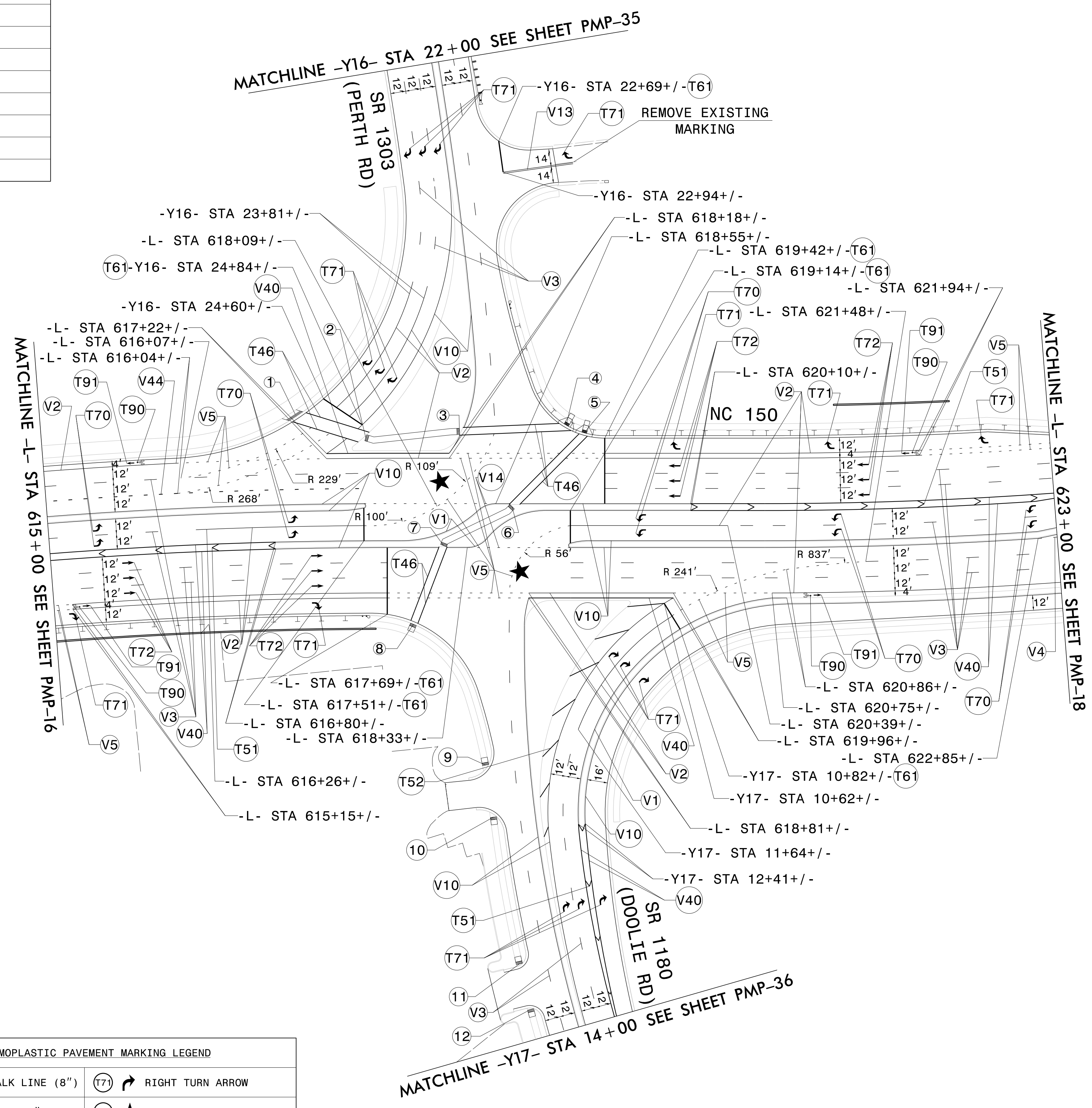

POLYUREA PAVEMENT MARKING LEGEND

V1	WHITE EDGELINE (4")
V2	WHITE SOLID LANE LINE (4")
V3	10 FT WHITE SKIP (4")
V4	3 FT-9 FT/SP WHITE MINISKIP (4")
V5	2 FT-6 FT/SP WHITE MINISKIP (4")

THERMOPLASTIC PAVEMENT MARKING LEGEND

V10	YELLOW EDGELINE (4")	T46	WHITE CROSSWALK LINE (8")	T71	RIGHT TURN ARROW
V13	YELLOW DOUBLE CENTER (4")	T51	WHITE DIAGONAL (12")	T72	STRAIGHT ARROW
V14	2 FT-6 FT/SP YELLOW MINISKIP (4")	T52	YELLOW DIAGONAL (12")	T90	BICYCLE SYMBOL
V40	WHITE GORELINE (8")	T61	WHITE STOPBAR (24")	T91	BICYCLE STRAIGHT ARROW
V44	3 FT-9 FT/SP WHITE MINISKIP (8")	T70	LEFT TURN ARROW		

★ PROPOSED SIGNAL

PAVEMENT MARKING DETAIL

\$\$\$\$\$SYTIME\$\$\$\$\$
\$\$\$\$\$DGN\$\$\$\$\$
\$\$\$\$\$USERNAME\$\$\$\$\$

TIP NO. R-2307B & I-5717	SHEET NO. PMP-18
APPROVED: <i>Betsy L. Watson</i> SEAL 29449	
DATE: 8/14/2024	
SEAL	
DOCUMENT NOT CONSIDERED FINAL UNLESS ALL SIGNATURES COMPLETED	

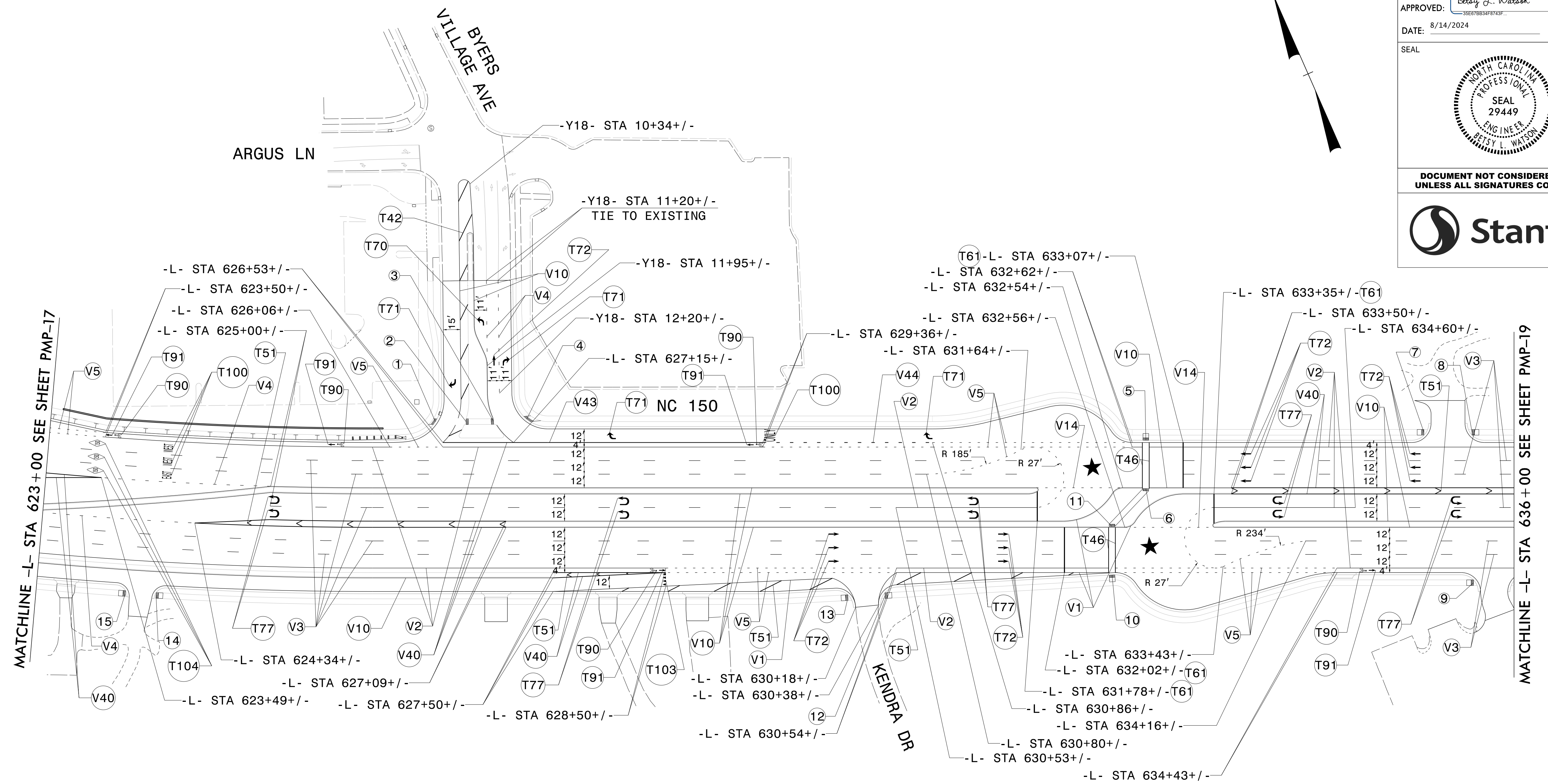



★ PROPOSED SIGNAL

THERMOPLASTIC PAVEMENT MARKING LEGEND			CURB RAMP STATIONS	
POLYUREA PAVEMENT MARKING LEGEND	(T42) YELLOW DIAGONAL (8")	(T100) ONLY ALPHANUMERIC CHARACTERS	1	-Y18- STA 12+44+/-
(V1) WHITE EDGELINE (4")	(T46) WHITE CROSSWALK LINE (8")	(T100) WEST ALPHANUMERIC CHARACTERS	2	-Y18- STA 12+45+/-
(V2) WHITE SOLID LANE LINE (4")	(T5) WHITE DIAGONAL (12")	(T103) ▼▼ 24" YIELD LINE TRIANGLE	3	-Y18- STA 12+45+/-
(V3) 10 FT WHITE SKIP (4")	(T6) WHITE STOPBAR (24")	(T104) ROUTE SHIELD ON DARK PAVEMENT	4	-Y18- STA 12+43+/-
(V4) 3 FT-9 FT/SP WHITE MINISKIP (4")	(T70) LEFT TURN ARROW		5	-L- STA 632+74+/-
(V5) 2 FT-6 FT/SP WHITE MINISKIP (4")	(T71) RIGHT TURN ARROW		6	-L- STA 632+74+/-
(V10) YELLOW EDGELINE (4")	(T72) STRAIGHT ARROW		7	-L- STA 635+20+/-
(V14) 2 FT-6 FT/SP YELLOW MINISKIP (4")	(T77) U-TURN ARROW		8	-L- STA 635+62+/-
(V40) WHITE GORELINE (8")	(T90) BICYCLE SYMBOL		9	-L- STA 635+63+/-
(V43) WHITE SOLID LANE LINE (8")	(T9) BICYCLE STRAIGHT ARROW		10	-L- STA 632+45+/-
(V44) 3 FT-9 FT/SP WHITE MINISKIP (8")	(T10) EAST ALPHANUMERIC CHARACTERS		11	-L- STA 632+44+/-
			12	-L- STA 630+44+/-
			13	-L- STA 630+11+/-
			14	-L- STA 624+04+/-
			15	-L- STA 623+77+/-

PAVEMENT MARKING DETAIL

\$\$\$\$\$SYTIME\$\$\$\$\$
\$\$\$\$\$DGN\$\$\$\$\$
\$\$\$\$\$USERNAME\$\$\$\$\$

TIP NO. R-2307B & I-5717	SHEET NO. PMP-19
APPROVED: <i>Betsy L. Watson</i> <small>35E97B834F8743F</small>	
DATE: 8/14/2024	
SEAL	
	
DOCUMENT NOT CONSIDERED FINAL UNLESS ALL SIGNATURES COMPLETED	
	

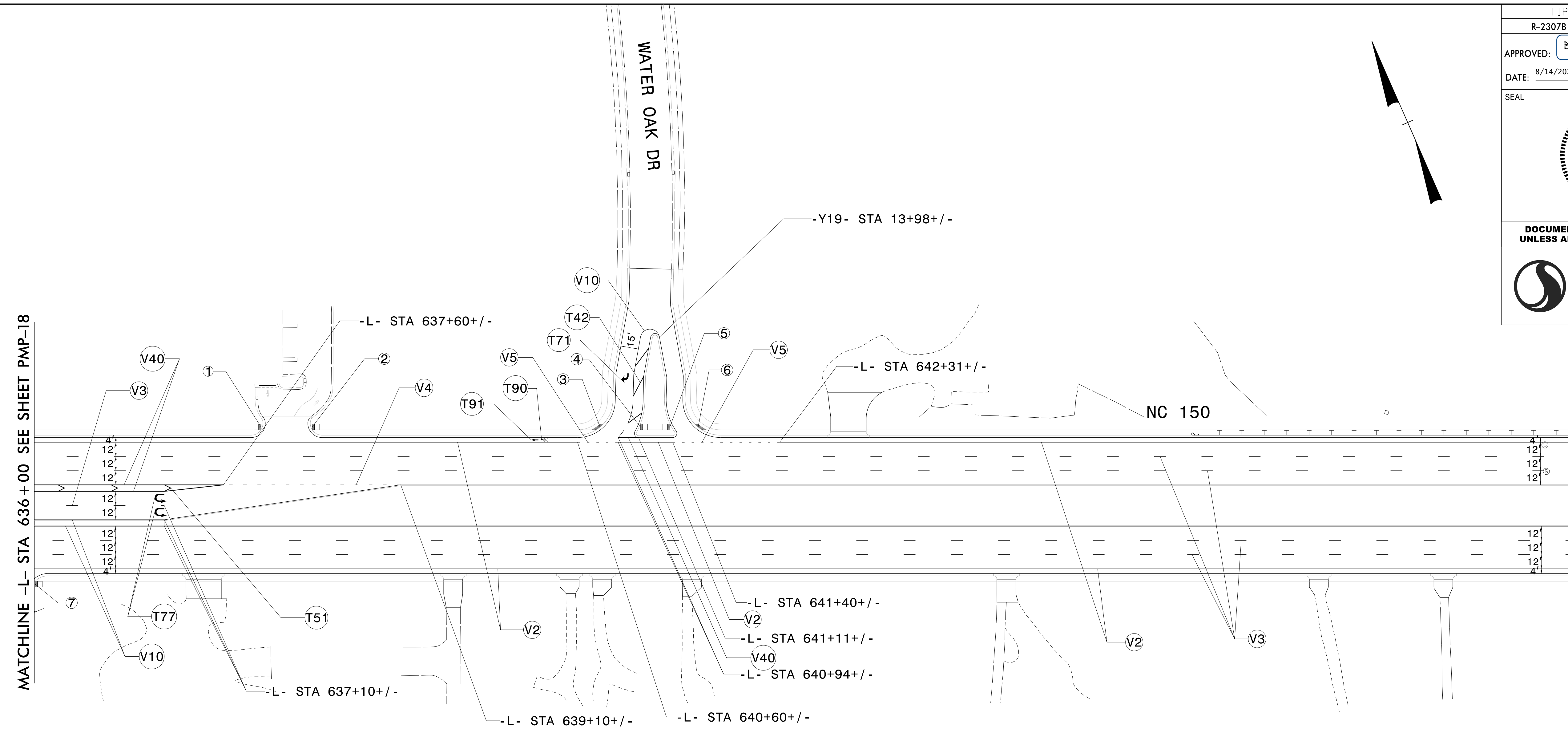
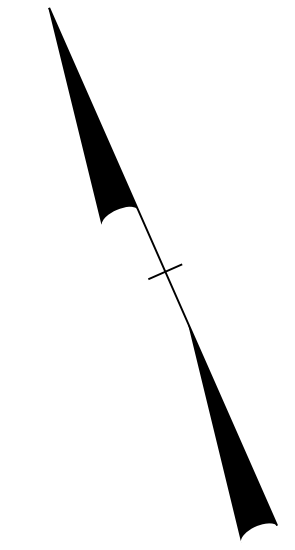

MATCHLINE -L- STA 636+00 SEE SHEET PMP-18

MATCHLINE -L- STA 649+00 SEE SHEET PMP-20

\$\$\$\$\$SYTIME\$\$\$\$\$
\$\$\$\$\$DGN\$\$\$\$\$
\$\$\$\$\$USERNAME\$\$\$\$\$

POLYUREA PAVEMENT MARKING LEGEND



V2	WHITE SOLID LANE LINE (4")
V3	10 FT WHITE SKIP (4")
V4	3 FT-9 FT/SP WHITE MINISKIP (4")
V5	2 FT-6 FT/SP WHITE MINISKIP (4")
V10	YELLOW EDGELINE (4")
V40	WHITE GORELINE (8")

THERMOPLASTIC PAVEMENT MARKING LEGEND

T42	YELLOW DIAGONAL (8")	T90	BICYCLE SYMBOL
T50	WHITE DIAGONAL (12")	T91	BICYCLE STRAIGHT ARROW
T71	RIGHT TURN ARROW		
T77	U-TURN ARROW		

	CURB RAMP STATIONS	CURB RAMP TYPE
1	-L- STA 637+92+/-	TYPE 1 MODIFIED
2	-L- STA 638+35+/-	TYPE 1 MODIFIED
3	-Y19- STA 14+75+/-	TYPE 1D
4	-Y19- STA 14+74+/-	TYPE 7
5	-Y19- STA 14+73+/-	TYPE 7
6	-Y19- STA 14+73+/-	TYPE 1D
7	-L- STA 636+01+/-	TYPE 1 MODIFIED

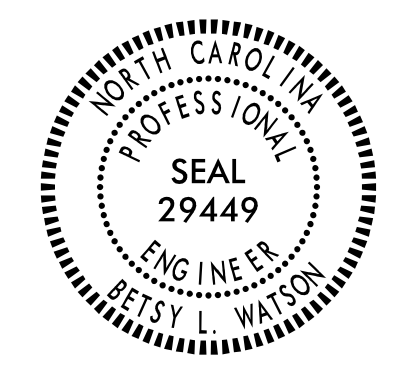
PAVEMENT MARKING DETAIL

TIP NO. R-2307B & I-5717	SHEET NO. PMP-20
APPROVED: <i>Betsy L. Watson</i> 35E97B83F8743F	
DATE: 8/14/2024	
SEAL	
	
DOCUMENT NOT CONSIDERED FINAL UNLESS ALL SIGNATURES COMPLETED	
	

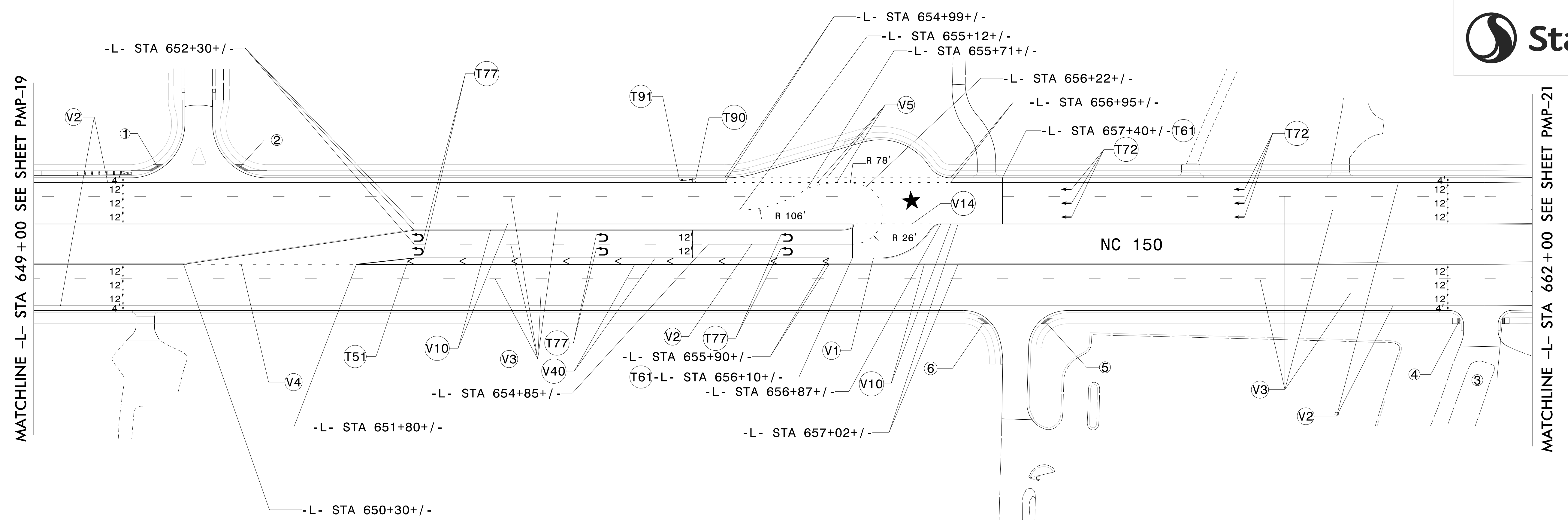
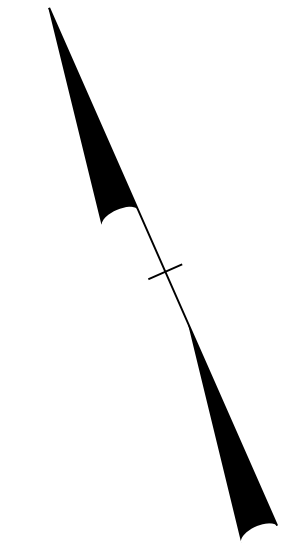

POLYUREA PAVEMENT MARKING LEGEND	
(V1)	WHITE EDGELINE (4")
(V2)	WHITE SOLID LANE LINE (4")
(V3)	10 FT WHITE SKIP (4")
(V4)	3 FT-9 FT/SP WHITE MINISKIP (4")
(V5)	2 FT-6 FT/SP WHITE MINISKIP (4")
(V10)	YELLOW EDGELINE (4")
(V14)	2 FT-6 FT/SP YELLOW MINISKIP (4")
(V40)	WHITE GORELINE (8")



★ PROPOSED SIGNAL

THERMOPLASTIC PAVEMENT MARKING LEGEND	
(T5)	WHITE DIAGONAL (12")
(T6)	WHITE STOPBAR (24")
(T72)	↑ STRAIGHT ARROW
(T77)	↪ U-TURN ARROW
(T90)	🚲 BICYCLE SYMBOL
(T91)	↑ BICYCLE STRAIGHT ARROW

	CURB RAMP STATIONS	CURB RAMP TYPE
①	-L- STA 650+08+/-	TYPE 1D
②	-L- STA 650+78+/-	TYPE 1D
③	-L- STA 661+74+/-	TYPE 1 MODIFIED
④	-L- STA 661+37+/-	TYPE 1 MODIFIED
⑤	-Y20- STA 10+66+/-	TYPE 1D
⑥	-Y20- STA 10+67+/-	TYPE 1D

PAVEMENT MARKING DETAIL

\$\$\$\$\$SYTIME\$\$\$\$\$
\$\$\$\$\$DGN\$\$\$\$\$
\$\$\$\$\$USERNAME\$\$\$\$\$

TIP NO. R-2307B & I-5717	SHEET NO. PMP-21
APPROVED: <i>Betsy L. Watson</i> <small>356978348743F</small>	
DATE: 8/14/2024	
SEAL	
	
DOCUMENT NOT CONSIDERED FINAL UNLESS ALL SIGNATURES COMPLETED	
	

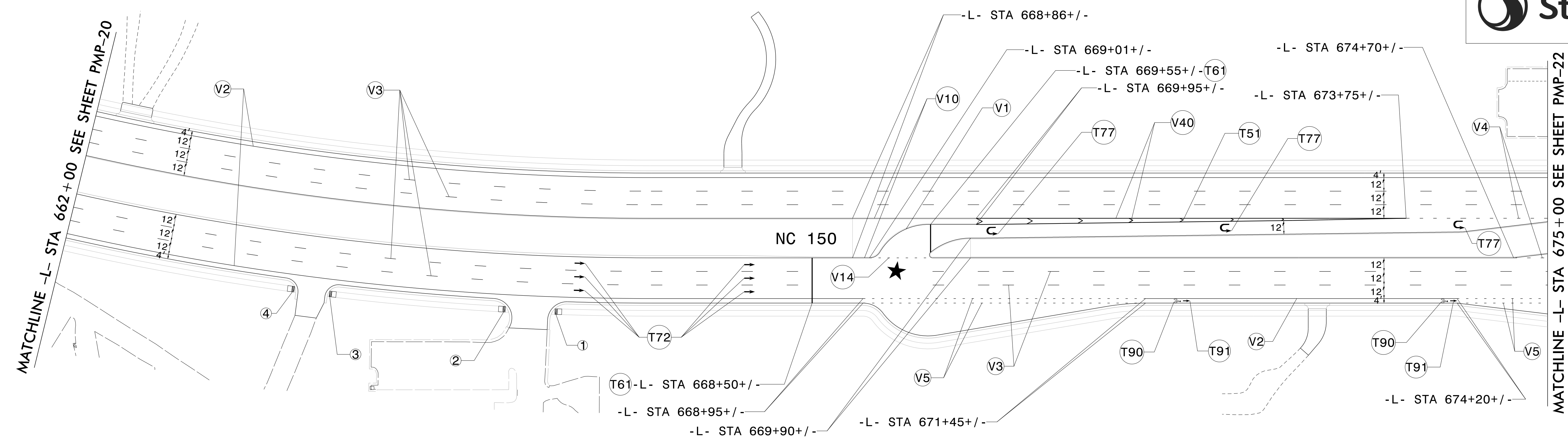

 PROPOSED SIGNAL

THERMOPLASTIC PAVEMENT MARKING LEGEND	
T51	WHITE DIAGONAL (12")
T61	WHITE STOPBAR (24")
T72	↑ STRAIGHT ARROW
T77	↪ U-TURN ARROW
T90	🚲 BICYCLE SYMBOL
T91	🚲 ↑ BICYCLE STRAIGHT ARROW

	CURB RAMP STATIONS	CURB RAMP TYPE
①	-L- STA 666+25+/-	TYPE 1 MODIFIED
②	-L- STA 665+82+/-	TYPE 1 MODIFIED
③	-L- STA 664+31+/-	TYPE 1 MODIFIED
④	-L- STA 664+00+/-	TYPE 1 MODIFIED

\$\$\$\$\$SYTIME\$\$\$\$\$
\$\$\$\$\$DGN\$\$\$\$\$
\$\$\$\$\$USERNAME\$\$\$\$\$

PAVEMENT MARKING DETAIL

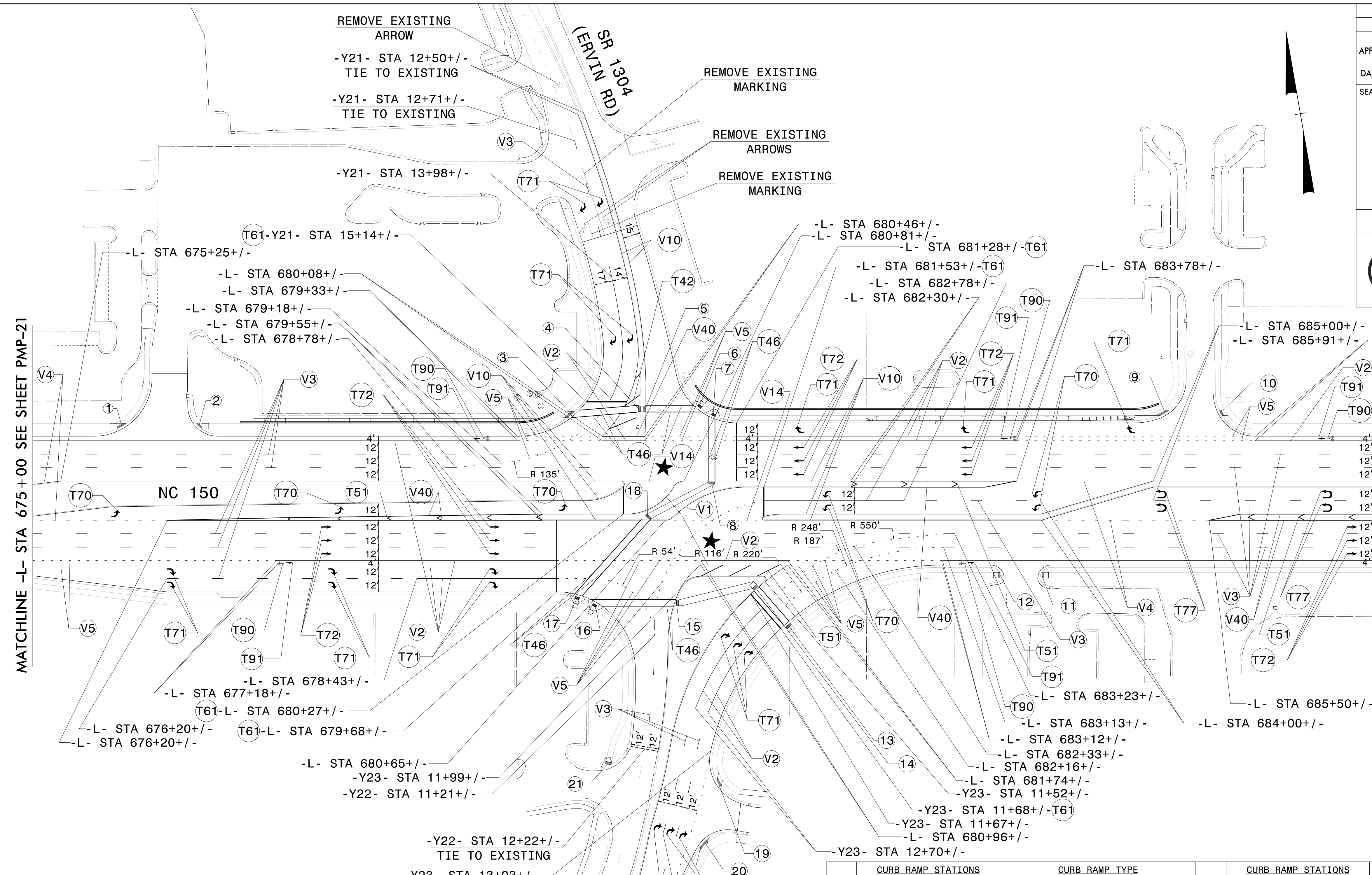

★ PROPOSED SIGNAL

POLYUREA PAVEMENT MARKING LEGEND

V1	WHITE EDGELINE (4")
V2	WHITE SOLID LANE LINE (4")
V3	10 FT WHITE SKIP (4")
V4	3 FT-9 FT/SP WHITE MINISKIP (4")
V5	2 FT-6 FT/SP WHITE MINISKIP (4")
V10	YELLOW EDGELINE (4")
V14	2 FT-6 FT/SP YELLOW MINISKIP (4")
V40	WHITE GORELINE (8")



THERMOPLASTIC PAVEMENT MARKING LEGEND

T42	YELLOW DIAGONAL (8")	T72	↑ STRAIGHT ARROW
T46	WHITE CROSSWALK LINE (8")	T77	↻ U-TURN ARROW
T50	WHITE DIAGONAL (12")	T90	🚲 BICYCLE SYMBOL
T60	WHITE STOPBAR (24")	T91	↑ BICYCLE STRAIGHT ARROW
T70	↶ LEFT TURN ARROW		
T71	↷ RIGHT TURN ARROW		

	CURB_RAMP_STATIONS	CURB_RAMP_TYPE		CURB_RAMP_STATIONS	CURB_RAMP_TYPE
1	-L- STA 675+80+/-	TYPE 1C/TYPE 1D COMBO	12	-L- STA 683+63+/-	TYPE 1
2	-L- STA 676+48+/-	TYPE 1C	13	-Y23- STA 11+60+/-	TYPE 3 MODIFIED
3	-Y21- STA 15+25+/-	TYPE 1D	14	-Y23- STA 11+60+/-	TYPE 7
4	-Y21- STA 15+20+/-	TYPE 7	15	-Y23- STA 12+08+/-	TYPE 7
5	-Y21- STA 15+20+/-	TYPE 7	16	-Y23- STA 12+36+/-	STANDARD
6	-Y21- STA 15+19+/-	STANDARD	17	-L- STA 679+86+/-	STANDARD
7	-L- STA 681+07+/-	STANDARD	18	-L- STA 680+49+/-	TYPE 7
8	-L- STA 681+06+/-	TYPE 7	19	-Y23- STA 13+30+/-	TYPE 1D
9	-Y24- STA 10+88+/-	TYPE 1D	20	-Y23- STA 13+81+/-	TYPE 1D
10	-Y24- STA 10+88+/-	TYPE 1D	21	-Y23- STA 13+34+/-	TYPE 1
11	-L- STA 684+01+/-	TYPE 1			

PAVEMENT MARKING DETAIL

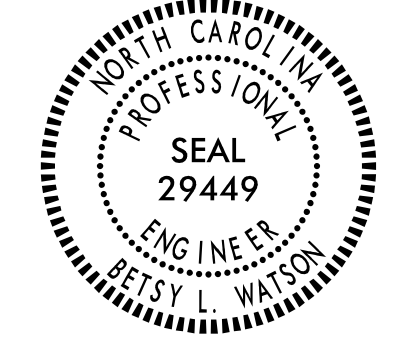
\$\$\$\$\$SYTIME\$\$\$\$\$
\$\$\$\$\$DGN\$\$\$\$\$
\$\$\$\$\$USERNAME\$\$\$\$\$

TIP NO. R-2307B & I-5717	SHEET NO. PMP-23
APPROVED: <i>Betsy L. Watson</i> SEAL 29449	
DATE: 8/14/2024	
SEAL	
	
DOCUMENT NOT CONSIDERED FINAL UNLESS ALL SIGNATURES COMPLETED	
	

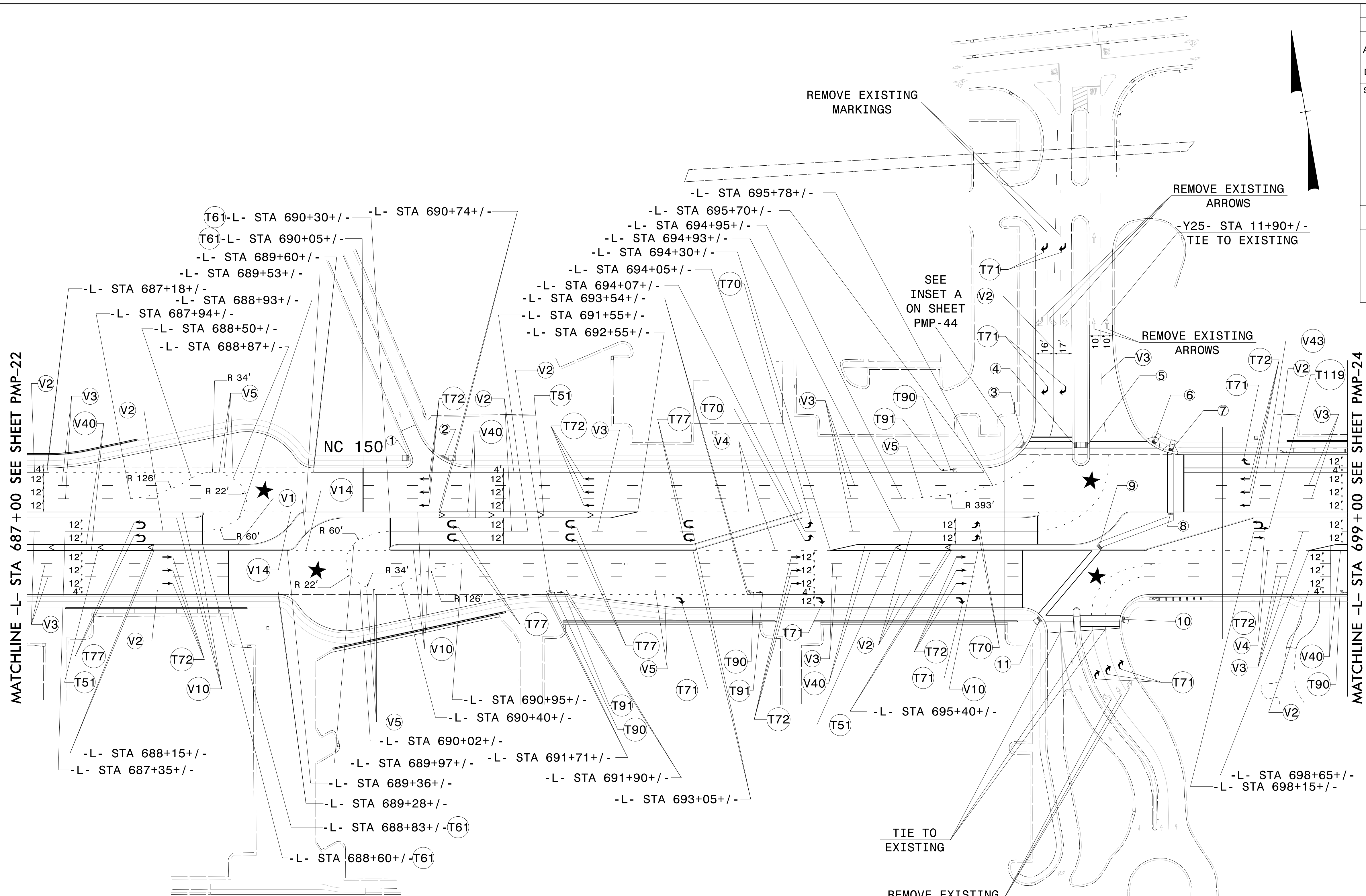

POLYUREA PAVEMENT MARKING LEGEND

(V1)	WHITE EDGELINE (4")
(V2)	WHITE SOLID LANE LINE (4")
(V3)	10 FT WHITE SKIP (4")
(V4)	3 FT-9 FT/SP WHITE MINISKIP (4")
(V5)	2 FT-6 FT/SP WHITE MINISKIP (4")
(V10)	YELLOW EDGELINE (4")
(V14)	2 FT-6 FT/SP YELLOW MINISKIP (4")
(V40)	WHITE GORELINE (8")
(V43)	WHITE SOLID LANE LINE (8")

 PROPOSED SIGNAL

THERMOPLASTIC PAVEMENT MARKING LEGEND

(T46)	WHITE CROSSWALK LINE (8")	(T90)	BICYCLE SYMBOL
(T5)	WHITE DIAGONAL (12")	(T91)	BICYCLE STRAIGHT ARROW
(T6)	WHITE STOPBAR (24")	(T119)	U-TURN/STRAIGHT ARROW
(T70)	LEFT TURN ARROW		
(T71)	RIGHT TURN ARROW		
(T72)	STRAIGHT ARROW		
(T77)	U-TURN ARROW		

	CURB RAMP STATIONS	CURB RAMP TYPE
(1)	-L- STA 690+47+/-	TYPE 1 MODIFIED
(2)	-L- STA 690+79+/-	TYPE 1C
(3)	-Y25- STA 12+99+/-	TYPE 1D
(4)	-Y25- STA 12+99+/-	TYPE 7
(5)	-Y25- STA 12+99+/-	TYPE 7
(6)	-Y25- STA 12+98+/-	STANDARD
(7)	-L- STA 697+39+/-	STANDARD
(8)	-L- STA 697+39+/-	TYPE 7
(9)	-L- STA 696+74+/-	TYPE 7
(10)	-L- STA 696+95+/-	TYPE 1A
(11)	-L- STA 696+21+/-	TYPE 2B/TYPE 3 MODIFIED COMBO

\$\$\$\$\$SYTIME\$\$\$\$\$
\$\$\$\$\$DGN\$\$\$\$\$
\$\$\$\$\$USERNAME\$\$\$\$\$

PAVEMENT MARKING DETAIL

TIP NO. R-2307B & I-5717	SHEET NO. PMP-24
APPROVED: <i>Betsy L. Watson</i> <small>REGISTERED PROFESSIONAL ENGINEER</small>	
DATE: 8/14/2024	
SEAL	
DOCUMENT NOT CONSIDERED FINAL UNLESS ALL SIGNATURES COMPLETED	

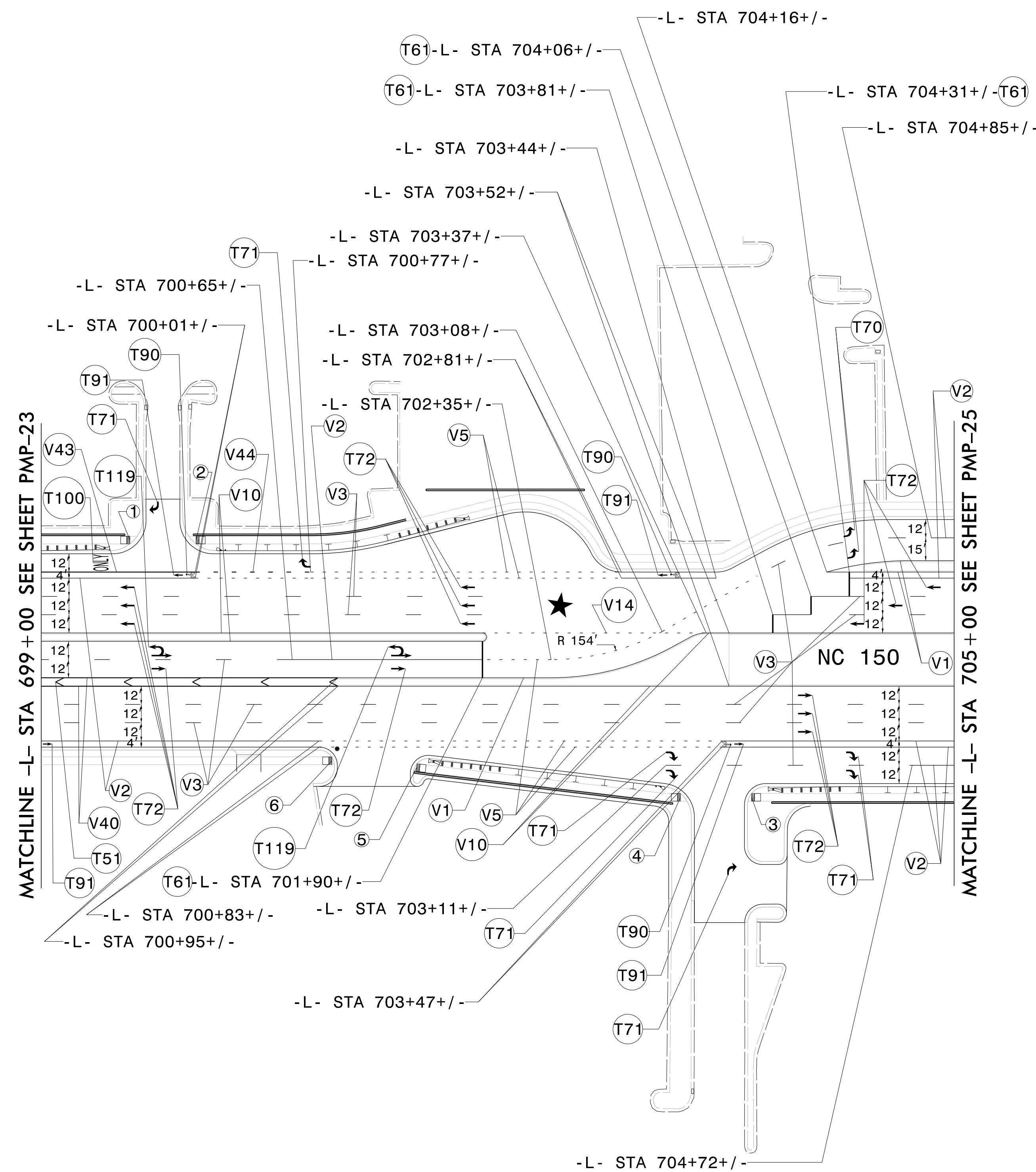

MATCHLINE -L- STA 699 + 00 SEE SHEET PMP-23

MATCHLINE -L- STA 705 + 00 SEE SHEET PMP-25

POLYUREA PAVEMENT MARKING LEGEND

(V1) WHITE EDGELINE (4")
(V2) WHITE SOLID LANE LINE (4")
(V3) 10 FT WHITE SKIP (4")
(V5) 2 FT-6 FT/SP WHITE MINISKIP (4")
(V10) YELLOW EDGELINE (4")
(V14) 2 FT-6 FT/SP YELLOW MINISKIP (4")
(V40) WHITE GORELINE (8")
(V43) WHITE SOLID LANE LINE (8")
(V44) 3 FT-9 FT/SP WHITE MINISKIP (8")



THERMOPLASTIC PAVEMENT MARKING LEGEND

(T5) WHITE DIAGONAL (12")	(T100) ONLY ALPHANUMERIC CHARACTERS
(T6) WHITE STOPBAR (24")	(T119) U-TURN/STRAIGHT ARROW
(T70) LEFT TURN ARROW	
(T71) RIGHT TURN ARROW	
(T72) STRAIGHT ARROW	
(T90) BICYCLE SYMBOL	
(T91) BICYCLE STRAIGHT ARROW	

	CURB RAMP STATIONS	CURB RAMP TYPE
①	-L- STA 699+58+/-	TYPE 1 MODIFIED
②	-L- STA 700+02+/-	TYPE 1 MODIFIED
③	-L- STA 703+67+/-	TYPE 1 MODIFIED
④	-L- STA 703+20+/-	TYPE 1 MODIFIED
⑤	-L- STA 701+47+/-	TYPE 1 MODIFIED
⑥	-L- STA 700+91+/-	TYPE 1 MODIFIED

\$\$\$\$\$SYTIME\$\$\$\$\$
\$\$\$\$\$DGN\$\$\$\$\$
\$\$\$\$\$USERNAM\$\$\$\$\$

PAVEMENT MARKING DETAIL

TIP NO. R-2307B & I-5717	SHEET NO. PMP-25
APPROVED: <i>Betsy L. Watson</i> SEAL 29449	
DATE: 8/14/2024	
SEAL	
	
DOCUMENT NOT CONSIDERED FINAL UNLESS ALL SIGNATURES COMPLETED	



	CURB RAMP STATIONS	CURB RAMP TYPE
1	-L- STA 706+19+/-	STANDARD
2	-Y26- STA 19+91+/-	STANDARD
3	-Y26- STA 19+91+/-	TYPE 1D
4	-L- STA 708+69+/-	TYPE 1 MODIFIED
5	-L- STA 709+06+/-	TYPE 1 MODIFIED
6	-Y28- STA 11+56+/-	TYPE 1C
7	-Y28- STA 11+73+/-	TYPE 1D
8	-Y26A- STA 11+35+/-	TYPE 3 MODIFIED
9	-Y26A- STA 11+16+/-	TYPE 7
10	-Y26A- STA 11+15+/-	TYPE 7
11	-Y26A- STA 11+27+/-	TYPE 3 MODIFIED
12	-L- STA 706+18+/-	TYPE 7
13	-L- STA 706+18+/-	TYPE 7
14	-Y26A- STA 13+07+/-	TYPE 1C
15	-Y26A- STA 13+56+/-	TYPE 1 MODIFIED
16	-Y26A- STA 14+96+/-	TYPE 1 MODIFIED
17	-Y26A- STA 14+26+/-	TYPE 1C

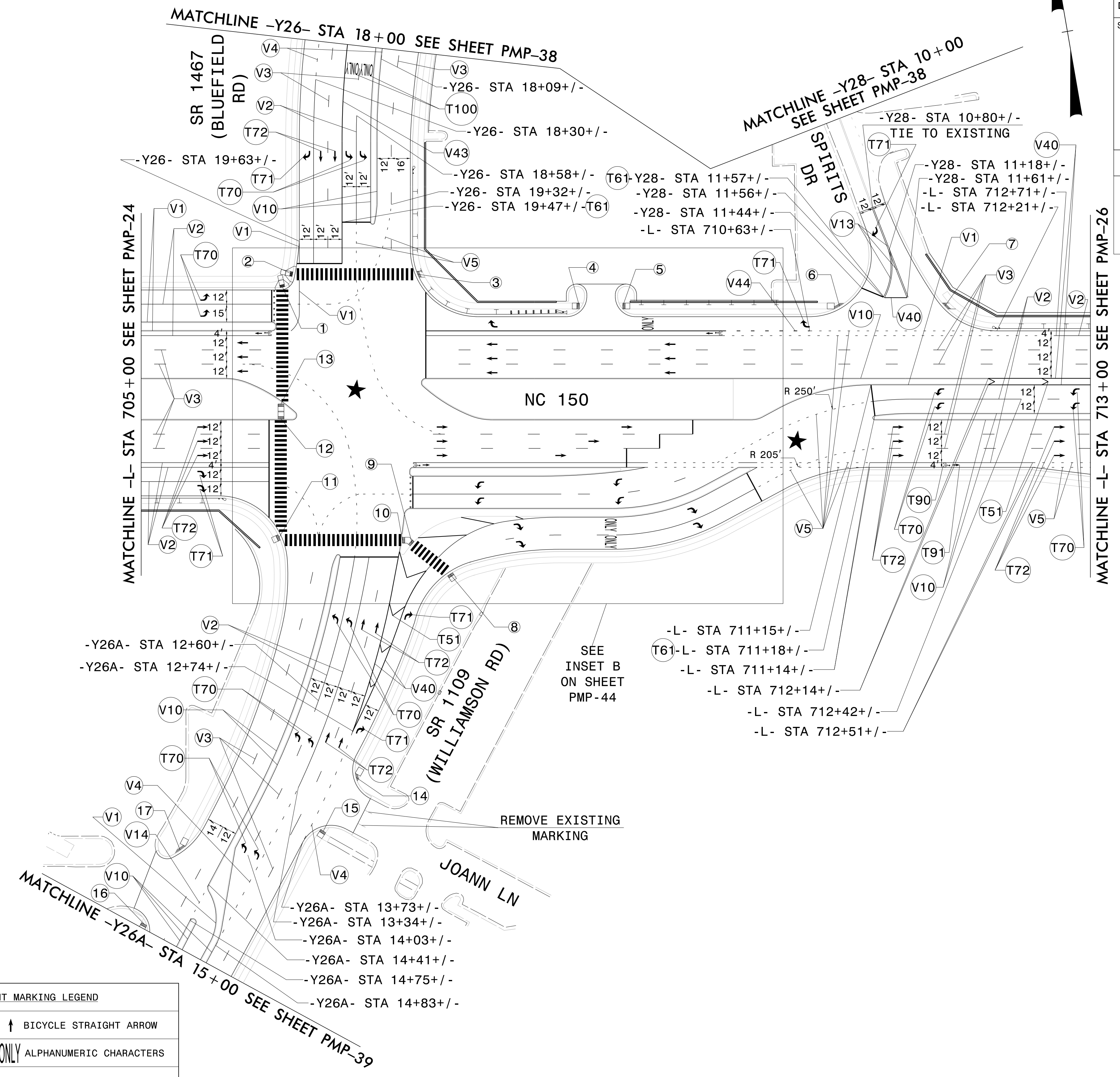

★ PROPOSED SIGNAL

POLYUREA PAVEMENT MARKING LEGEND

V1	WHITE EDGELINE (4")
V2	WHITE SOLID LANE LINE (4")
V3	10 FT WHITE SKIP (4")
V4	3 FT-9 FT/SP WHITE MINISKIP (4")
V5	2 FT-6 FT/SP WHITE MINISKIP (4")
V10	YELLOW EDGELINE (4")
V13	YELLOW DOUBLE CENTER (4")
V14	2 FT-6 FT/SP YELLOW MINISKIP (4")
V40	WHITE GORELINE (8")
V43	WHITE SOLID LANE LINE (8")
V44	3 FT-9 FT/SP WHITE MINISKIP (8")

THERMOPLASTIC PAVEMENT MARKING LEGEND

T51	WHITE DIAGONAL (12")	T91	↑ BICYCLE STRAIGHT ARROW
T61	WHITE STOPBAR (24")	T100	ONLY ALPHANUMERIC CHARACTERS
T70	↶ LEFT TURN ARROW		
T71	↷ RIGHT TURN ARROW		
T72	↑ STRAIGHT ARROW		
T90	♻ BICYCLE SYMBOL		

\$\$\$\$\$SYTIME\$\$\$\$\$
\$\$\$\$\$DGN\$\$\$\$\$
\$\$\$\$\$USERNAME\$\$\$\$\$

PAVEMENT MARKING DETAIL

TIP NO. R-2307B & I-5717	SHEET NO. PMP-26
APPROVED: <i>Betsy L. Watson</i> <small>REGISTERED PROFESSIONAL ENGINEER</small>	
DATE: 8/14/2024	
SEAL	
DOCUMENT NOT CONSIDERED FINAL UNLESS ALL SIGNATURES COMPLETED	

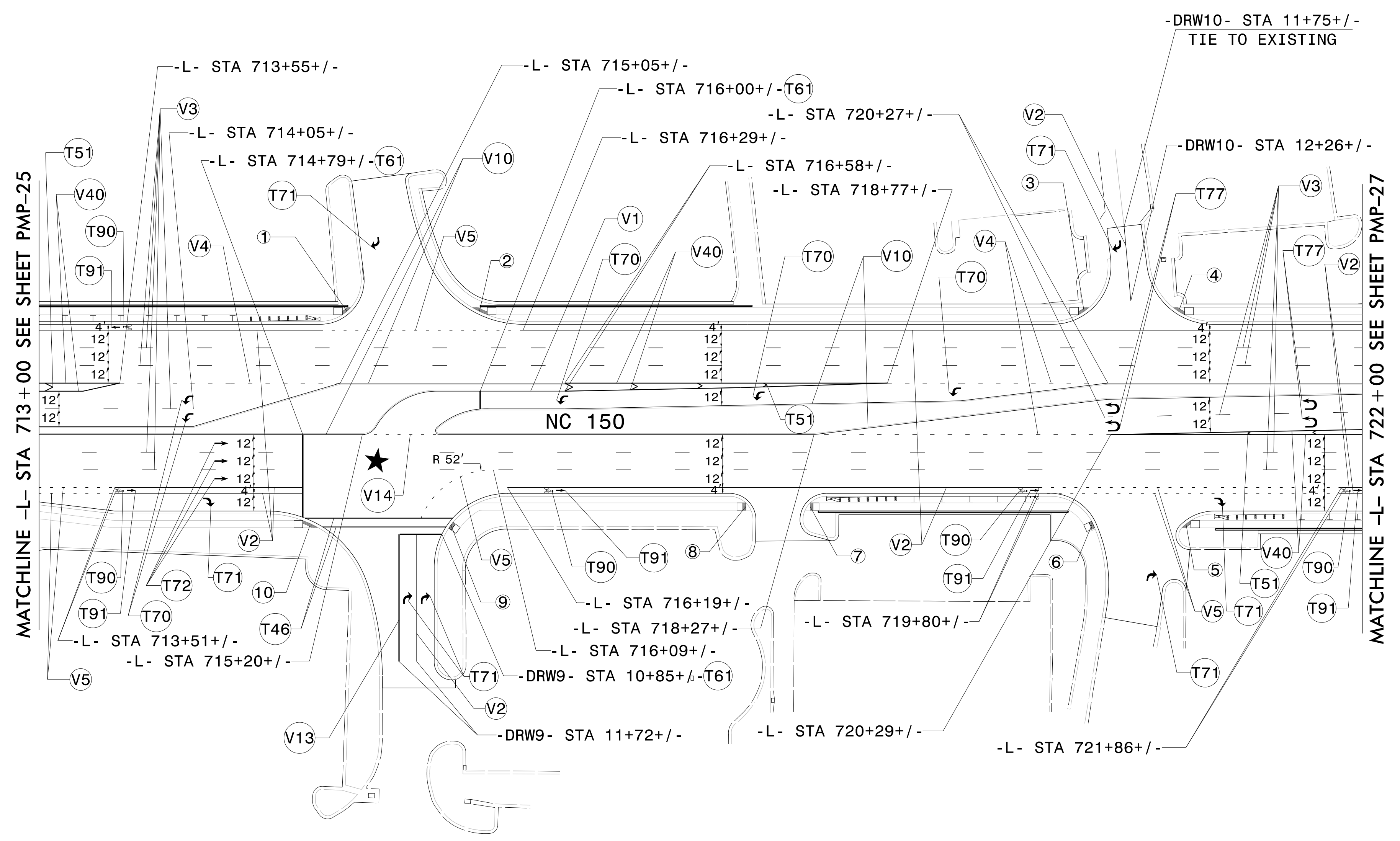

MATCHLINE -L- STA 713+00 SEE SHEET PMP-25

MATCHLINE -L- STA 722+00 SEE SHEET PMP-27

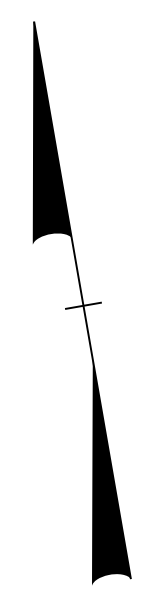



POLYUREA PAVEMENT MARKING LEGEND	
(V1)	WHITE EDGELINE (4")
(V2)	WHITE SOLID LANE LINE (4")
(V3)	10 FT WHITE SKIP (4")
(V4)	3 FT-9 FT/SP WHITE MINISKIP (4")
(V5)	2 FT-6 FT/SP WHITE MINISKIP (4")
(V10)	YELLOW EDGELINE (4")
(V13)	YELLOW DOUBLE CENTER (4")
(V14)	2 FT-6 FT/SP YELLOW MINISKIP (4")
(V40)	WHITE GORELINE (8")

★ PROPOSED SIGNAL	
THERMOPLASTIC PAVEMENT MARKING LEGEND	
(T46)	WHITE CROSSWALK LINE (8")
(T51)	WHITE DIAGONAL (12")
(T61)	WHITE STOPBAR (24")
(T70)	LEFT TURN ARROW
(T71)	RIGHT TURN ARROW
(T72)	STRAIGHT ARROW
(T77)	U-TURN ARROW
(T90)	BICYCLE SYMBOL
(T91)	BICYCLE STRAIGHT ARROW

	CURB RAMP STATIONS	CURB RAMP TYPE
(1)	-L- STA 715+09+/-	TYPE 1C
(2)	-L- STA 716+00+/-	TYPE 1C
(3)	-L- STA 720+11+/-	TYPE 1C
(4)	-L- STA 720+75+/-	TYPE 1C
(5)	-DRW11- STA 10+77+/-	TYPE 1C
(6)	-DRW11- STA 10+81+/-	TYPE 1A
(7)	-L- STA 718+24+/-	TYPE 1 MODIFIED
(8)	-L- STA 717+81+/-	TYPE 1 MODIFIED
(9)	-DRW9- STA 10+79+/-	TYPE 1A
(10)	-DRW9- STA 10+78+/-	TYPE 1C

PAVEMENT MARKING DETAIL

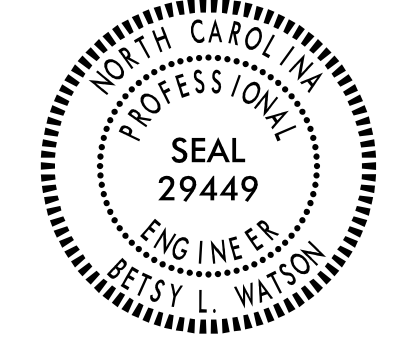
\$\$\$\$\$SYTIME\$\$\$\$\$
\$\$\$\$\$DGN\$\$\$\$\$
\$\$\$\$\$USERNAM\$\$\$\$\$

TIP NO. R-2307B & I-5717	SHEET NO. PMP-27
APPROVED: <i>Betsy L. Watson</i> 30E97B34F8743F	
DATE: 8/14/2024	
SEAL	
	
DOCUMENT NOT CONSIDERED FINAL UNLESS ALL SIGNATURES COMPLETED	
	

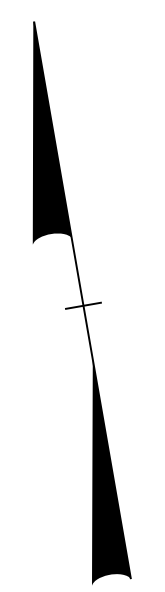

	CURB RAMP STATIONS	CURB RAMP TYPE
1	-Y29- STA 16+91+/-	TYPE 3 MODIFIED
2	-Y29- STA 16+88+/-	TYPE 7
3	-Y29- STA 16+89+/-	TYPE 7
4	-Y29- STA 16+74+/-	TYPE 1A
5	-L- STA 724+65+/-	TYPE 1
6	-L- STA 724+64+/-	TYPE 1
7	-Y30- STA 10+84+/-	TYPE 1C
8	-Y30- STA 10+79+/-	TYPE 7
9	-Y30- STA 10+78+/-	TYPE 7
10	-Y30- STA 10+73+/-	TYPE 1C

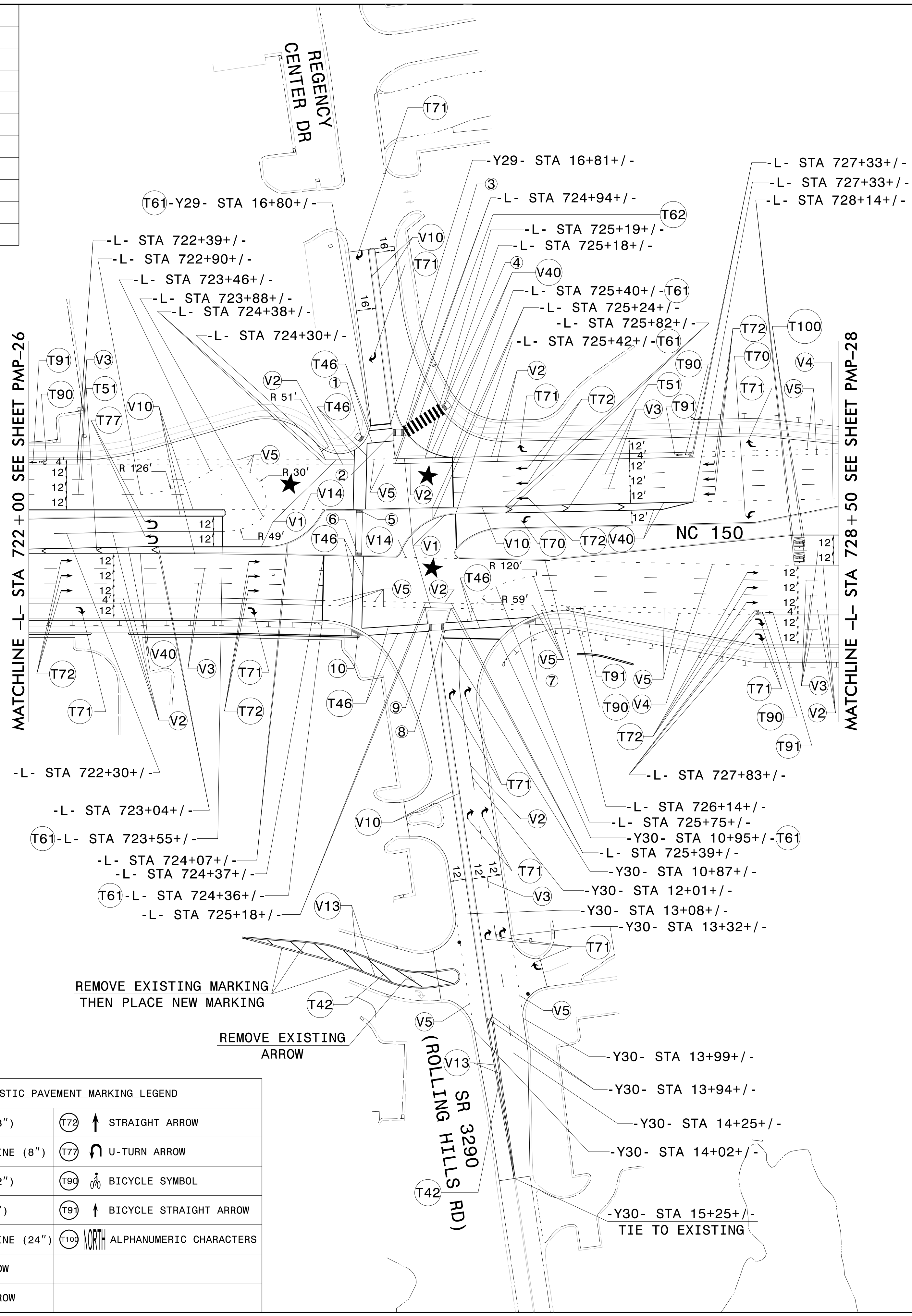

★ PROPOSED SIGNAL

POLYUREA PAVEMENT MARKING LEGEND

V1	WHITE EDGELINE (4")
V2	WHITE SOLID LANE LINE (4")
V3	10 FT WHITE SKIP (4")
V4	3 FT-9 FT/SP WHITE MINISKIP (4")
V5	2 FT-6 FT/SP WHITE MINISKIP (4")
V10	YELLOW EDGELINE (4")
V13	YELLOW DOUBLE CENTER (4")
V14	2 FT-6 FT/SP YELLOW MINISKIP (4")
V40	WHITE GORELINE (8")

THERMOPLASTIC PAVEMENT MARKING LEGEND

T42	YELLOW DIAGONAL (8")	T72	↑ STRAIGHT ARROW
T46	WHITE CROSSWALK LINE (8")	T77	↻ U-TURN ARROW
T5	WHITE DIAGONAL (12")	T96	🚲 BICYCLE SYMBOL
T6	WHITE STOPBAR (24")	T91	↑ BICYCLE STRAIGHT ARROW
T61	WHITE CROSSWALK LINE (24")	T100	NORTH ALPHANUMERIC CHARACTERS
T70	↶ LEFT TURN ARROW		
T71	↷ RIGHT TURN ARROW		

REMOVE EXISTING MARKING THEN PLACE NEW MARKING

REMOVE EXISTING ARROW

\$\$\$\$\$SYTIME\$\$\$\$\$
\$\$\$\$\$DGN\$\$\$\$\$
\$\$\$\$\$USERNAME\$\$\$\$\$

PAVEMENT MARKING DETAIL

TIP NO. R-2307B & I-5717	SHEET NO. PMP-28
APPROVED: <i>Betsy L. Watson</i> SEAL 29449	
DATE: 8/14/2024	
SEAL	
DOCUMENT NOT CONSIDERED FINAL UNLESS ALL SIGNATURES COMPLETED	



	CURB RAMP STATIONS	CURB RAMP TYPE
1	-Y31RPA- STA 18+95+/-	TYPE 1C
2	-Y31RPA- STA 18+89+/-	TYPE 7
3	-Y31RPA- STA 18+88+/-	TYPE 7
4	-Y31RPA- STA 18+84+/-	TYPE 1 MODIFIED
5	-Y31RPD- STA 22+73+/-	TYPE 1 MODIFIED
6	-Y31RPD- STA 23+02+/-	TYPE 1C
7	-Y31RPC- STA 20+26+/-	TYPE 1C
8	-Y31RPC- STA 20+30+/-	TYPE 7
9	-Y31RPC- STA 20+30+/-	TYPE 7
10	-Y31RPC- STA 20+30+/-	TYPE 1 MODIFIED
11	-Y31RPB- STA 21+93+/-	TYPE 1 MODIFIED
12	-Y31RPB- STA 21+94+/-	TYPE 1C

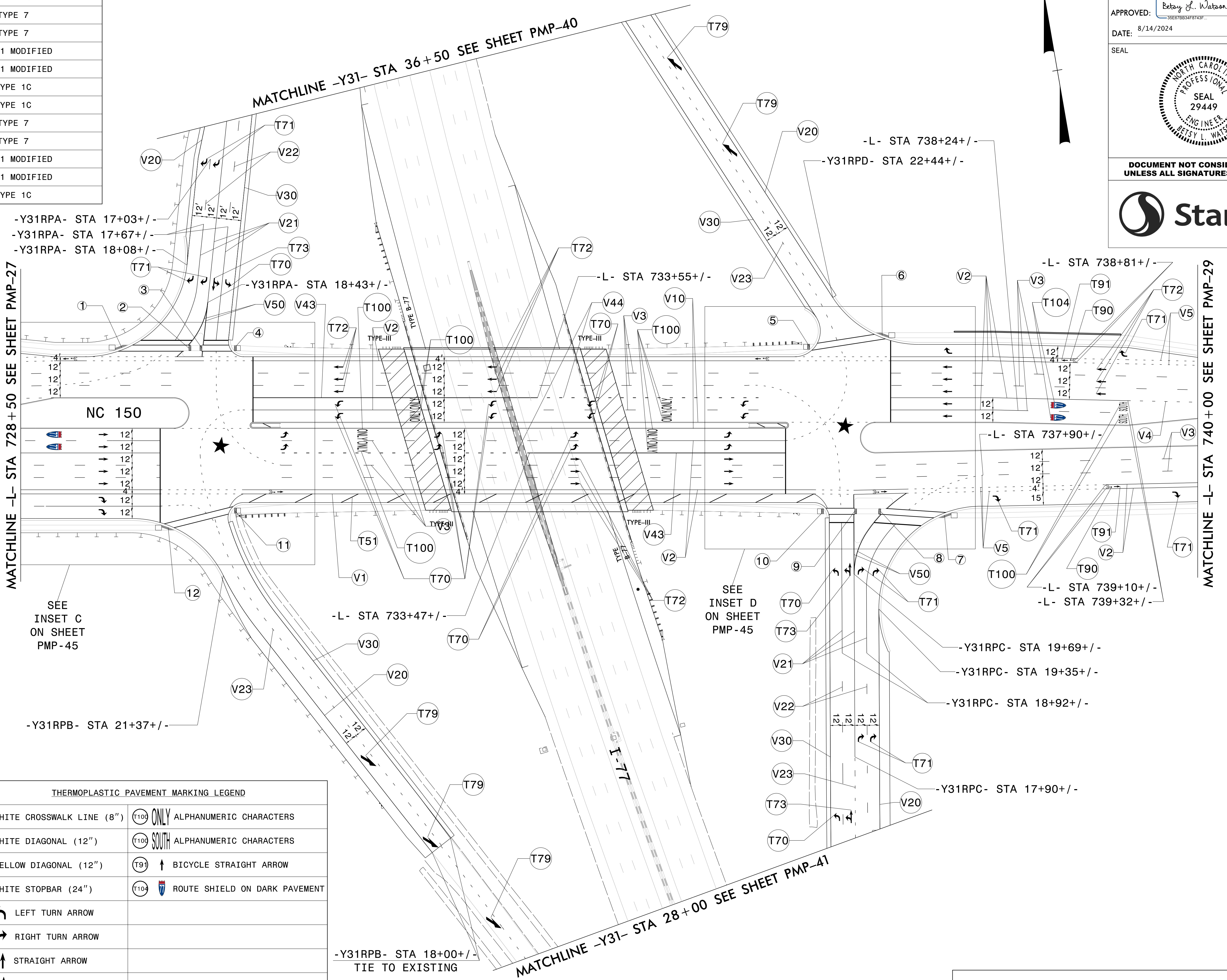

★ PROPOSED SIGNAL

POLYUREA PAVEMENT MARKING LEGEND

V1	WHITE EDGELINE (4")
V2	WHITE SOLID LANE LINE (4")
V3	10 FT WHITE SKIP (4")
V4	3 FT-9 FT/SP WHITE MINISKIP (4")
V5	2 FT-6 FT/SP WHITE MINISKIP (4")
V10	YELLOW EDGELINE (4")
V20	WHITE EDGELINE (6")
V21	WHITE SOLID LANE LINE (6")
V22	10 FT WHITE SKIP (6")
V23	3 FT-9 FT/SP WHITE MINISKIP (6")
V30	YELLOW EDGELINE (6")
V43	WHITE SOLID LANE LINE (8")
V44	3 FT-9 FT/SP WHITE MINISKIP (8")
V50	WHITE GORELINE (12")

THERMOPLASTIC PAVEMENT MARKING LEGEND

T46	WHITE CROSSWALK LINE (8")	T100	ONLY ALPHANUMERIC CHARACTERS
T51	WHITE DIAGONAL (12")	T109	SOUTH ALPHANUMERIC CHARACTERS
T52	YELLOW DIAGONAL (12")	T91	BICYCLE STRAIGHT ARROW
T61	WHITE STOPBAR (24")	T104	ROUTE SHIELD ON DARK PAVEMENT
T70	LEFT TURN ARROW		
T71	RIGHT TURN ARROW		
T72	STRAIGHT ARROW		
T73	LEFT/STRAIGHT ARROW		
T73	MERGE ARROW		
T90	BICYCLE SYMBOL		

\$\$\$\$\$SYTIME\$\$\$\$\$
\$\$\$\$\$DGN\$\$\$\$\$
\$\$\$\$\$USERNAME\$\$\$\$\$

PAVEMENT MARKING DETAIL

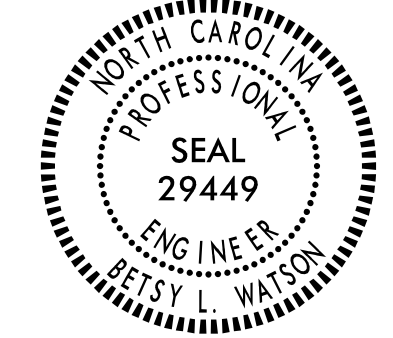
TIP NO. R-2307B & I-5717	SHEET NO. PMP-29
APPROVED: <i>Betsy L. Watson</i> 29449	
DATE: 8/14/2024	
SEAL	
	
DOCUMENT NOT CONSIDERED FINAL UNLESS ALL SIGNATURES COMPLETED	



	CURB RAMP STATIONS	CURB RAMP TYPE
1	-L- STA 741+37+/-	TYPE 3 MODIFIED
2	-L- STA 742+16+/-	TYPE 1C
3	-L- STA 744+16+/-	TYPE 4A
4	-Y34- STA 12+90+/-	TYPE 4A
5	-Y34- STA 12+97+/-	TYPE 1A
6	-L- STA 748+67+/-	TYPE 1 MODIFIED
7	-L- STA 749+24+/-	TYPE 1 MODIFIED
8	-L- STA 749+14+/-	TYPE 1 MODIFIED
9	-L- STA 748+77+/-	TYPE 1 MODIFIED
10	-L- STA 747+85+/-	TYPE 1 MODIFIED
11	-L- STA 747+48+/-	TYPE 1 MODIFIED
12	-L- STA 747+05+/-	TYPE 1C
13	-L- STA 746+73+/-	TYPE 1 MODIFIED
14	-L- STA 746+09+/-	TYPE 1 MODIFIED
15	-L- STA 745+68+/-	TYPE 1 MODIFIED
16	-L- STA 745+08+/-	TYPE 4C
17	-Y35- STA 11+06+/-	TYPE 4C
18	-Y35- STA 11+01+/-	TYPE 7
19	-Y35- STA 10+97+/-	TYPE 7
20	-Y35- STA 11+02+/-	TYPE 2
21	-Y32- STA 10+79+/-	TYPE 1C
22	-Y32- STA 10+82+/-	TYPE 1C
23	-L- STA 744+41+/-	TYPE 7
24	-L- STA 744+62+/-	TYPE 7
25	-Y35- STA 12+45+/-	TYPE 1C
26	-Y35- STA 12+87+/-	TYPE 1C
27	-Y35- STA 13+87+/-	TYPE 1C
28	-Y35- STA 13+04+/-	TYPE 1C
29	-Y35- STA 12+70+/-	TYPE 1C
30	-Y35- STA 14+45+/-	TYPE 1A

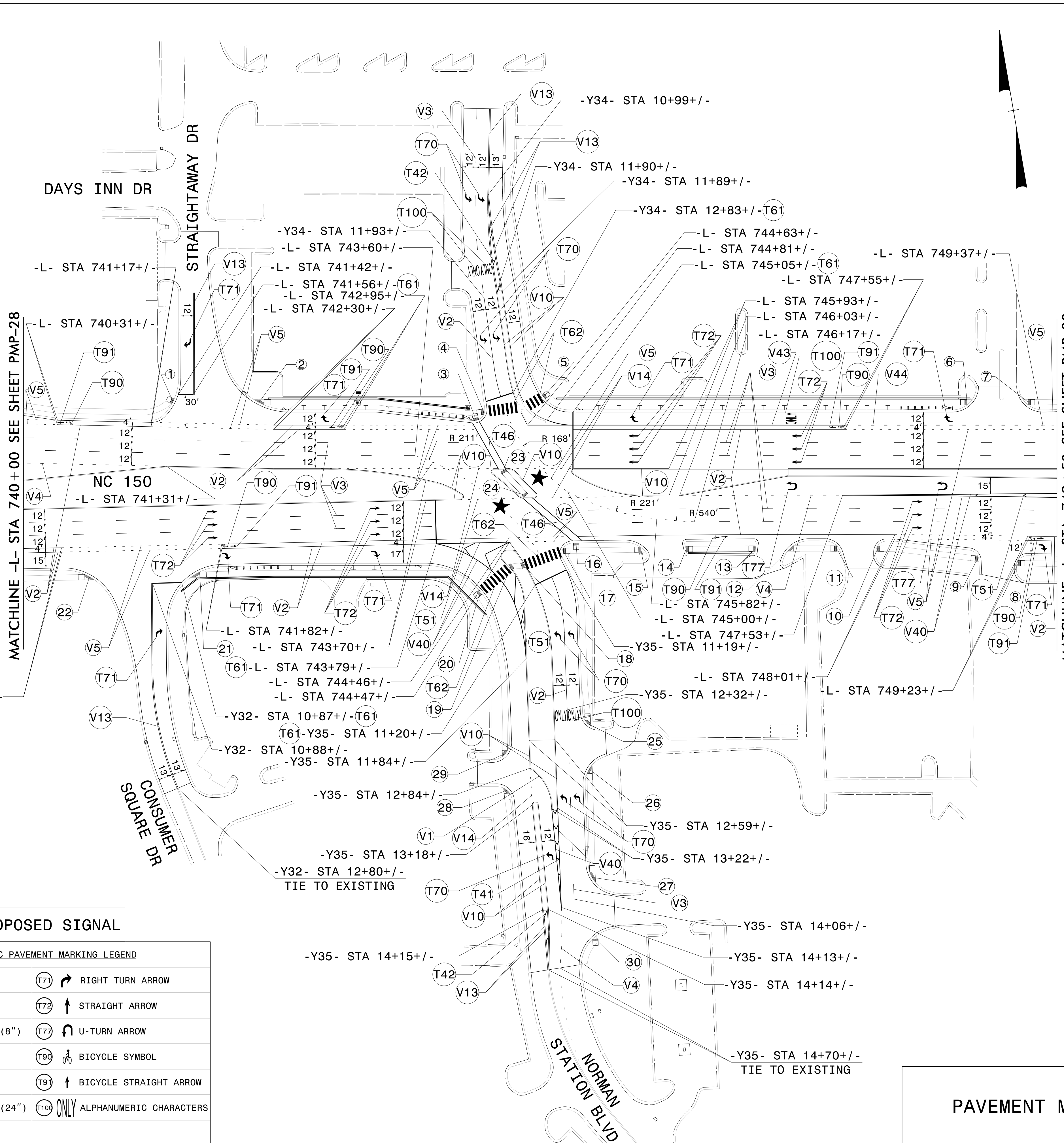

POLYUREA PAVEMENT MARKING LEGEND

V2	WHITE SOLID LANE LINE (4")
V3	10 FT WHITE SKIP (4")
V4	3 FT-9 FT/SP WHITE MINISKIP (4")
V5	2 FT-6 FT/SP WHITE MINISKIP (4")
V10	YELLOW EDGELINE (4")
V13	YELLOW DOUBLE CENTER (4")
V14	2 FT-6 FT/SP YELLOW MINISKIP (4")
V40	WHITE GORELINE (8")
V43	WHITE SOLID LANE LINE (8")
V44	3 FT-9 FT/SP WHITE MINISKIP (8")





THERMOPLASTIC PAVEMENT MARKING LEGEND

T41	WHITE DIAGONAL (8")	T71	RIGHT TURN ARROW
T42	YELLOW DIAGONAL (8")	T72	STRAIGHT ARROW
T46	WHITE CROSSWALK LINE (8")	T77	U-TURN ARROW
T51	WHITE DIAGONAL (12")	T90	BICYCLE SYMBOL
T61	WHITE STOPBAR (24")	T91	BICYCLE STRAIGHT ARROW
T62	WHITE CROSSWALK LINE (24")	T100	ONLY ALPHANUMERIC CHARACTERS
T70	LEFT TURN ARROW		

\$\$\$\$\$\$SYTIME\$\$\$\$\$\$
 \$\$\$\$\$\$DGN\$\$\$\$\$\$
 \$\$\$\$\$\$USERNAME\$\$\$\$\$\$

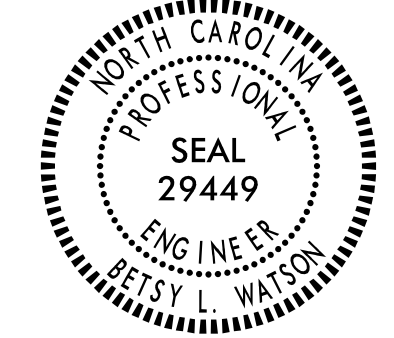
PAVEMENT MARKING DETAIL

TIP NO. R-2307B & I-5717	SHEET NO. PMP-30
APPROVED: <i>Betsy L. Watson</i>	
DATE: 8/14/2024	
SEAL	
	
DOCUMENT NOT CONSIDERED FINAL UNLESS ALL SIGNATURES COMPLETED	
	

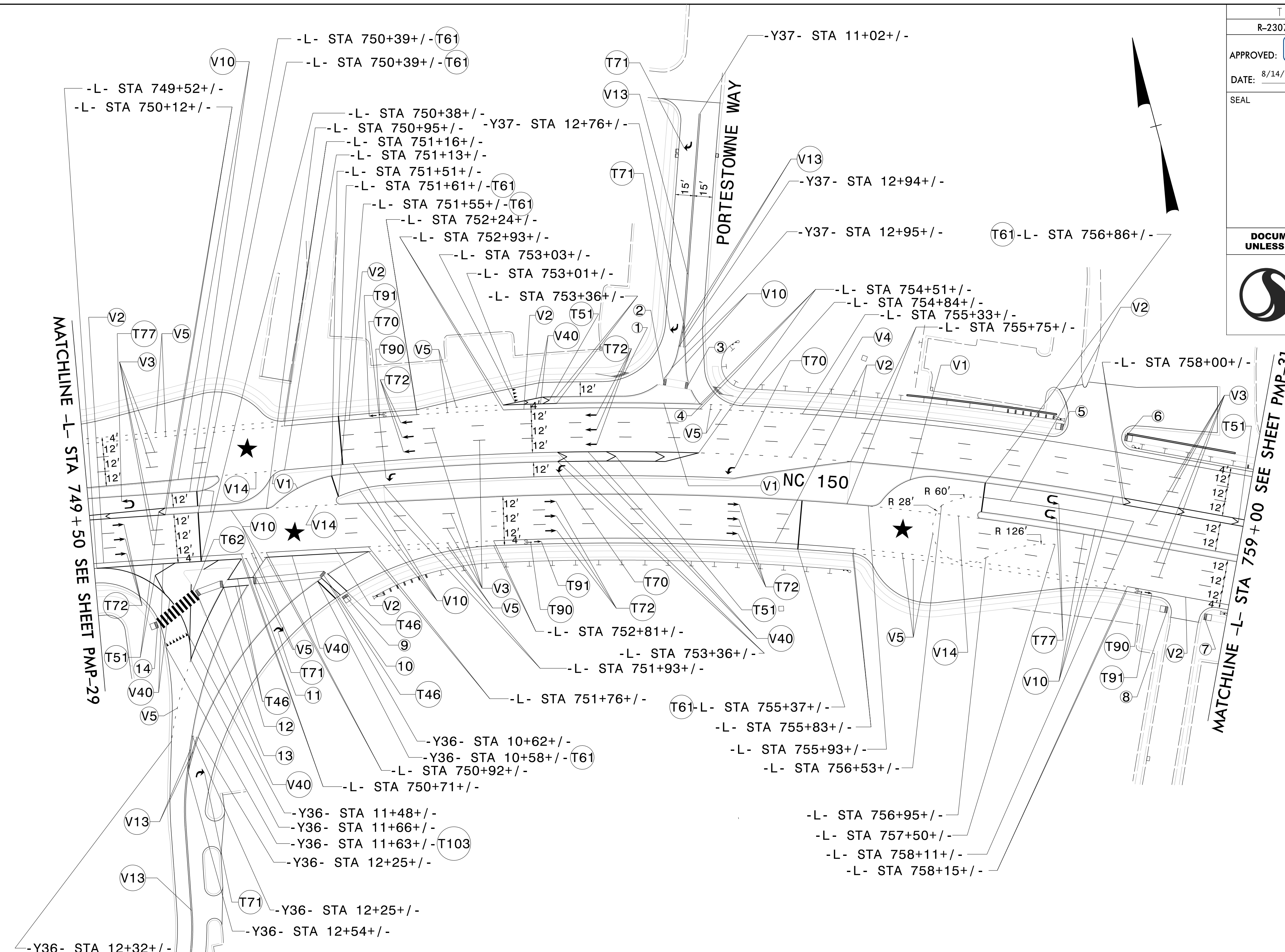

★ PROPOSED SIGNAL

POLYUREA PAVEMENT MARKING LEGEND

V1	WHITE EDGLINE (4")
V2	WHITE SOLID LANE LINE (4")
V3	10 FT WHITE SKIP (4")
V4	3 FT-9 FT/SP WHITE MINISKIP (4")
V5	2 FT-6 FT/SP WHITE MINISKIP (4")
V10	YELLOW EDGLINE (4")
V13	YELLOW DOUBLE CENTER (4")
V14	2 FT-6 FT/SP YELLOW MINISKIP (4")
V40	WHITE GORELINE (8")



THERMOPLASTIC PAVEMENT MARKING LEGEND

T46	WHITE CROSSWALK LINE (8")	T77	U-TURN ARROW
T51	WHITE DIAGONAL (12")	T90	BICYCLE SYMBOL
T61	WHITE STOPBAR (24")	T91	BICYCLE STRAIGHT ARROW
T62	WHITE CROSSWALK LINE (24")	T103	▼▼▼ 24" YIELD LINE TRIANGLE
T70	LEFT TURN ARROW		
T71	RIGHT TURN ARROW		
T72	STRAIGHT ARROW		

CURB RAMP STATIONS	CURB RAMP TYPE
1 -Y37- STA 13+21+/-	TYPE 1D
2 -Y37- STA 13+24+/-	TYPE 7
3 -Y37- STA 13+26+/-	TYPE 7
4 -Y37- STA 13+28+/-	TYPE 1D
5 -L- STA 757+42+/-	TYPE 1 MODIFIED
6 -L- STA 757+92+/-	TYPE 1 MODIFIED
7 -L- STA 758+82+/-	TYPE 1 MODIFIED
8 -L- STA 758+51+/-	TYPE 1 MODIFIED
9 -Y36- STA 10+56+/-	TYPE 3 MODIFIED
10 -Y36- STA 10+51+/-	TYPE 7
11 -Y36- STA 10+86+/-	TYPE 7
12 -Y36- STA 11+01+/-	TYPE 7
13 -Y36- STA 11+17+/-	TYPE 7
14 -Y36- STA 11+49+/-	TYPE 1A

PAVEMENT MARKING DETAIL

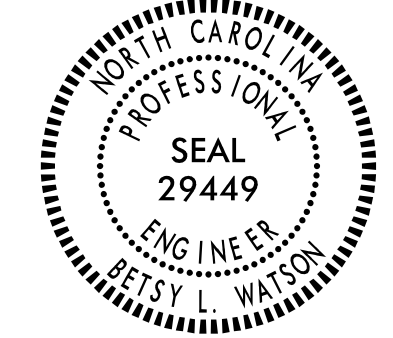
\$\$\$\$\$SYTIME\$\$\$\$\$
\$\$\$\$\$DGN\$\$\$\$\$
\$\$\$\$\$USERNAME\$\$\$\$\$

TIP NO. R-2307B & I-5717	SHEET NO. PMP-31
APPROVED: <i>Betsy L. Watson</i> <small>REGISTERED BY 35697B34F8743F</small>	
DATE: 8/14/2024	
SEAL	
	
DOCUMENT NOT CONSIDERED FINAL UNLESS ALL SIGNATURES COMPLETED	
	

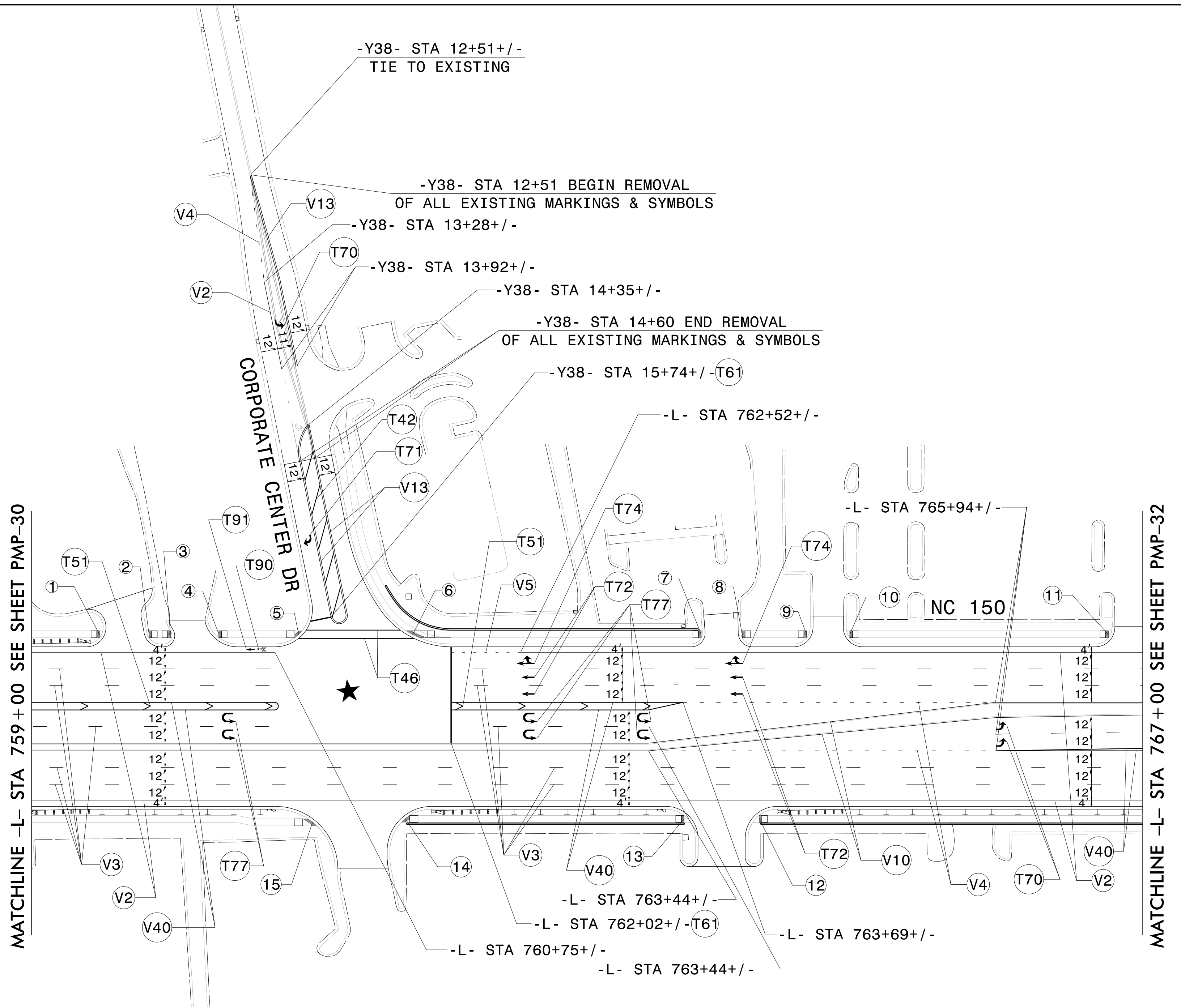
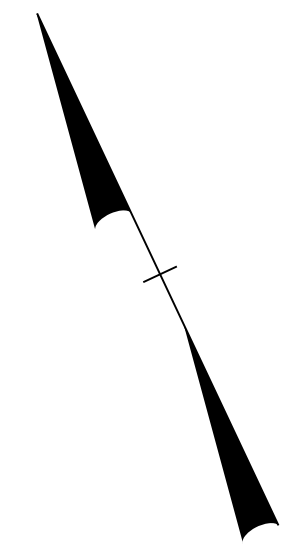



\$\$\$SYTIME\$\$\$\$\$
 \$\$\$DGN\$\$\$\$\$
 \$\$\$USERNAME\$\$\$\$\$

POLYUREA PAVEMENT MARKING LEGEND		THERMOPLASTIC PAVEMENT MARKING LEGEND	
(V2) WHITE SOLID LANE LINE (4")	(T42) YELLOW DIAGONAL (8")	(T74) STRAIGHT/RIGHT ARROW	
(V3) 10 FT WHITE SKIP (4")	(T46) WHITE CROSSWALK LINE (8")	(T77) U-TURN ARROW	
(V4) 3 FT-9 FT/SP WHITE MINISKIP (4")	(T5) WHITE DIAGONAL (12")	(T96) BICYCLE SYMBOL	
(V5) 2 FT-6 FT/SP WHITE MINISKIP (4")	(T6) WHITE STOPBAR (24")	(T91) BICYCLE STRAIGHT ARROW	
(V10) YELLOW EDGELINE (4")	(T70) LEFT TURN ARROW		
(V13) YELLOW DOUBLE CENTER (4")	(T7) RIGHT TURN ARROW		
(V40) WHITE GORELINE (8")	(T2) STRAIGHT ARROW		

CURB RAMP STATIONS	CURB RAMP TYPE
① -L- STA 759+49+/-	TYPE 1 MODIFIED
② -L- STA 759+84+/-	TYPE 1 MODIFIED
③ -L- STA 760+00+/-	TYPE 1 MODIFIED
④ -L- STA 760+35+/-	TYPE 1 MODIFIED
⑤ -Y38- STA 15+82+/-	TYPE 1C
⑥ -Y38- STA 15+98+/-	TYPE 1D
⑦ -L- STA 763+82+/-	TYPE 1 MODIFIED
⑧ -L- STA 764+12+/-	TYPE 1 MODIFIED
⑨ -L- STA 764+58+/-	TYPE 1 MODIFIED
⑩ -L- STA 764+89+/-	TYPE 1 MODIFIED
⑪ -L- STA 766+75+/-	TYPE 1 MODIFIED
⑫ -L- STA 764+24+/-	TYPE 1 MODIFIED
⑬ -L- STA 763+70+/-	TYPE 1 MODIFIED
⑭ -L- STA 761+69+/-	TYPE 1C
⑮ -L- STA 761+02+/-	TYPE 1C

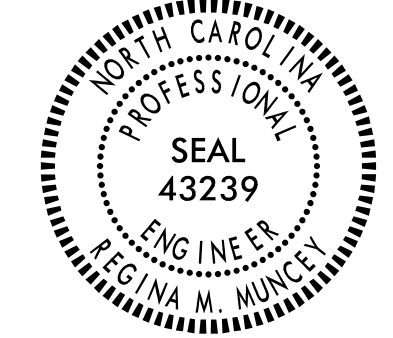
PAVEMENT MARKING DETAIL

TIP NO. R-2307B & I-5717	SHEET NO. PMP-32
APPROVED: <i>Regina M. Muncy</i> <small>Professional Engineer</small>	
DATE: 9/25/2024	
SEAL 	
DOCUMENT NOT CONSIDERED FINAL UNLESS ALL SIGNATURES COMPLETED	
	

	CURB RAMP STATIONS	CURB RAMP TYPE
1	-L- STA 767+17+/-	TYPE 1 MODIFIED
2	-Y39- STA 19+06+/-	TYPE 3 MODIFIED
3	-Y39- STA 19+37+/-	TYPE 7
4	-Y39- STA 19+49+/-	TYPE 7
5	-Y39- STA 19+61+/-	TYPE 1C
6	-L- STA 772+92+/-	TYPE 1 MODIFIED
7	-L- STA 773+34+/-	TYPE 1 MODIFIED
8	-L- STA 775+50+/-	TYPE 1 MODIFIED
9	-L- STA 775+96+/-	TYPE 1 MODIFIED
10	-L- STA 776+41+/-	TYPE 1 MODIFIED
11	-L- STA 776+08+/-	TYPE 1 MODIFIED
12	-L- STA 774+65+/-	TYPE 1 MODIFIED
13	-L- STA 774+37+/-	TYPE 1 MODIFIED
14	-Y40- STA 10+84+/-	TYPE 3 MODIFIED
15	-Y40- STA 10+62+/-	TYPE 7
16	-Y40- STA 10+67+/-	TYPE 7
17	-Y40- STA 10+71+/-	STANDARD
18	-L- STA 770+53+/-	TYPE 7
19	-L- STA 770+84+/-	TYPE 7

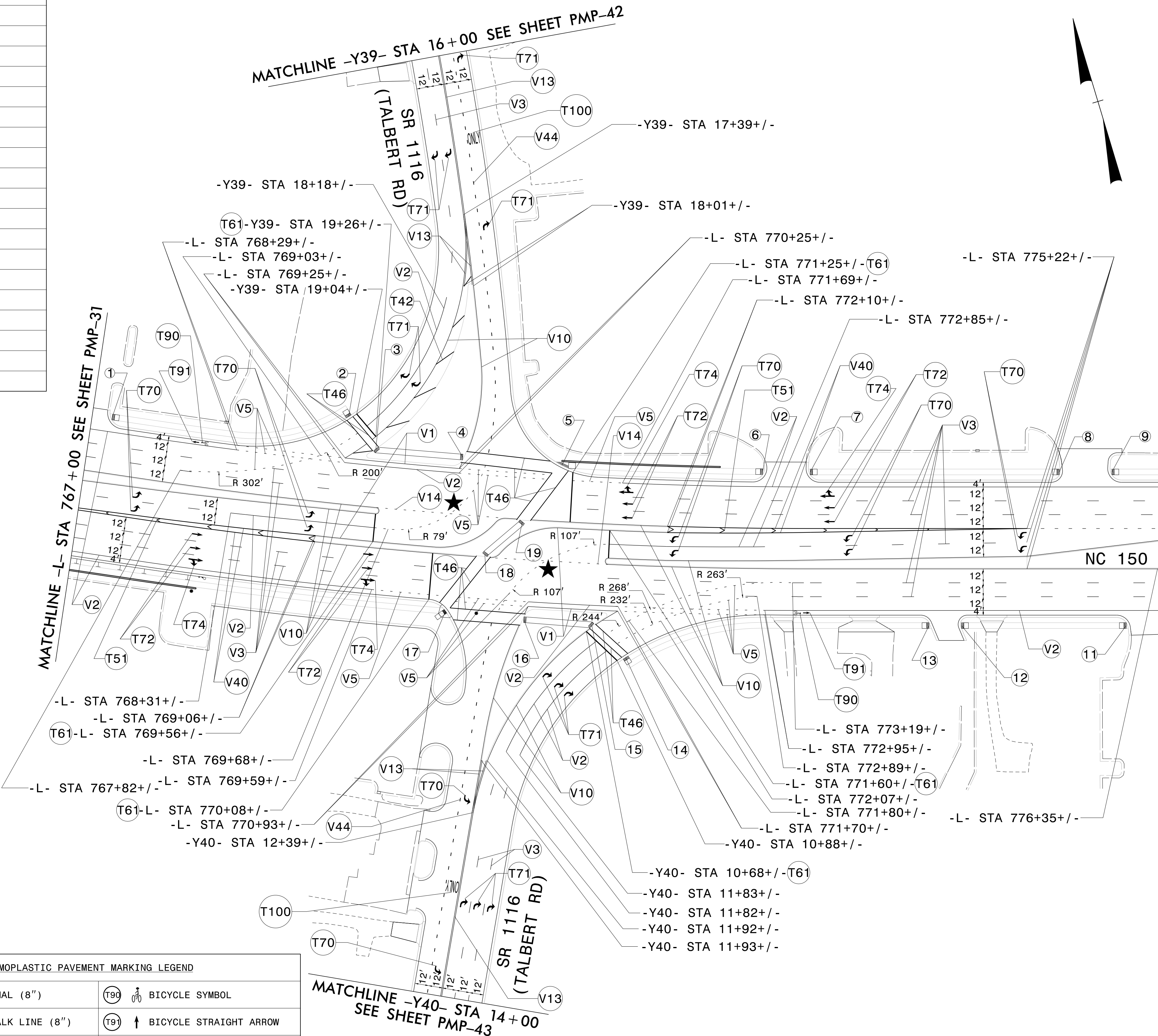

 PROPOSED SIGNAL

POLYUREA PAVEMENT MARKING LEGEND



V1	WHITE EDGELINE (4")
V2	WHITE SOLID LANE LINE (4")
V3	10 FT WHITE SKIP (4")
V4	3 FT-9 FT/SP WHITE MINISKIP (4")
V5	2 FT-6 FT/SP WHITE MINISKIP (4")
V10	YELLOW EDGELINE (4")
V13	YELLOW DOUBLE CENTER (4")
V14	2 FT-6 FT/SP YELLOW MINISKIP (4")
V40	WHITE GORELINE (8")
V44	3 FT-9 FT/SP WHITE MINISKIP (8")

THERMOPLASTIC PAVEMENT MARKING LEGEND

T42	YELLOW DIAGONAL (8")	T90	BICYCLE SYMBOL
T46	WHITE CROSSWALK LINE (8")	T91	BICYCLE STRAIGHT ARROW
T51	WHITE DIAGONAL (12")	T100	ONLY ALPHANUMERIC CHARACTERS
T61	WHITE STOPBAR (24")		
T70	LEFT TURN ARROW		
T71	RIGHT TURN ARROW		
T72	STRAIGHT ARROW		
T74	STRAIGHT/RIGHT ARROW		

\$\$\$\$\$SYTIME\$\$\$\$\$
\$\$\$\$\$DDGN\$\$\$\$\$
\$\$\$\$\$USERNAME\$\$\$\$\$

PAVEMENT MARKING DETAIL

TIP NO. R-2307B & I-5717	SHEET NO. PMP-33
APPROVED: <i>Betsy L. Watson</i> 35E77B34F8743F	
DATE: 8/14/2024	
SEAL	
	
DOCUMENT NOT CONSIDERED FINAL UNLESS ALL SIGNATURES COMPLETED	
	

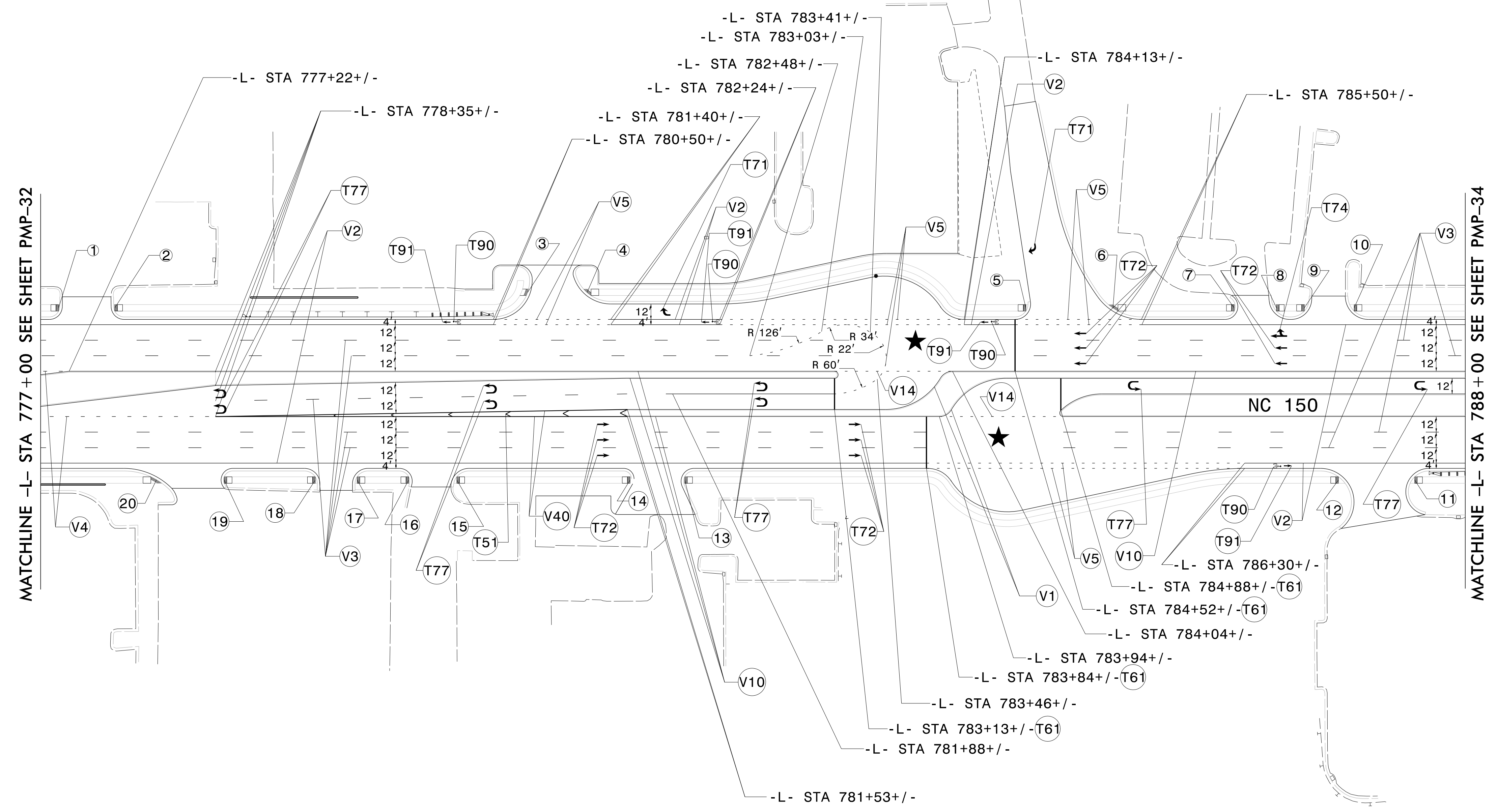

MATCHLINE -L- STA 777 + 00 SEE SHEET PMP-32

MATCHLINE -L- STA 788 + 00 SEE SHEET PMP-34

POLYUREA PAVEMENT MARKING LEGEND		THERMOPLASTIC PAVEMENT MARKING LEGEND		CURB RAMP STATIONS		CURB RAMP STATIONS	
(V1) WHITE EDGELINE (4")	(T5) WHITE DIAGONAL (12")	(T90) BICYCLE SYMBOL	(1) -L- STA 777+14+/-	TYPE 1 MODIFIED	(11) -L- STA 787+61+/-	TYPE 1 MODIFIED	
(V2) WHITE SOLID LANE LINE (4")	(T6) WHITE STOPBAR (24")	(T91) BICYCLE STRAIGHT ARROW	(2) -L- STA 777+57+/-	TYPE 1 MODIFIED	(12) -L- STA 787+02+/-	TYPE 1 MODIFIED	
(V3) 10 FT WHITE SKIP (4")	(T7) RIGHT TURN ARROW		(3) -L- STA 780+76+/-	TYPE 1D	(13) -L- STA 781+97+/-	TYPE 1 MODIFIED	
(V4) 3 FT-9 FT/SP WHITE MINISKIP (4")	(T72) STRAIGHT ARROW		(4) -L- STA 781+22+/-	TYPE 1C	(14) -L- STA 781+55+/-	TYPE 1 MODIFIED	
(V5) 2 FT-6 FT/SP WHITE MINISKIP (4")	(T74) STRAIGHT/RIGHT ARROW		(5) -Y45- STA 12+06+/-	TYPE 1 MODIFIED	(15) -L- STA 780+21+/-	TYPE 1 MODIFIED	
(V10) YELLOW EDGELINE (4")	(T77) U-TURN ARROW		(6) -Y45- STA 12+17+/-	TYPE 1C	(16) -L- STA 779+84+/-	TYPE 1 MODIFIED	
(V14) 2 FT-6 FT/SP YELLOW MINISKIP (4")			(7) -L- STA 786+22+/-	TYPE 1 MODIFIED	(17) -L- STA 779+44+/-	TYPE 1 MODIFIED	
(V40) WHITE GORELINE (8")			(8) -L- STA 786+54+/-	TYPE 1 MODIFIED	(18) -L- STA 779+12+/-	TYPE 1 MODIFIED	
			(9) -L- STA 786+76+/-	TYPE 1 MODIFIED	(19) -L- STA 778+42+/-	TYPE 1 MODIFIED	
			(10) -L- STA 787+14+/-	TYPE 1 MODIFIED	(20) -L- STA 777+89+/-	TYPE 1C	

\$\$\$\$\$SYTIME\$\$\$\$\$
\$\$\$\$\$DGN\$\$\$\$\$
\$\$\$\$\$USERNAME\$\$\$\$\$

PAVEMENT MARKING DETAIL

TIP NO. R-2307B & I-5717	SHEET NO. PMP-34
APPROVED: <i>Betsy L. Watson</i> 35E97B38F8743F	
DATE: 8/14/2024	
SEAL	
	
DOCUMENT NOT CONSIDERED FINAL UNLESS ALL SIGNATURES COMPLETED	

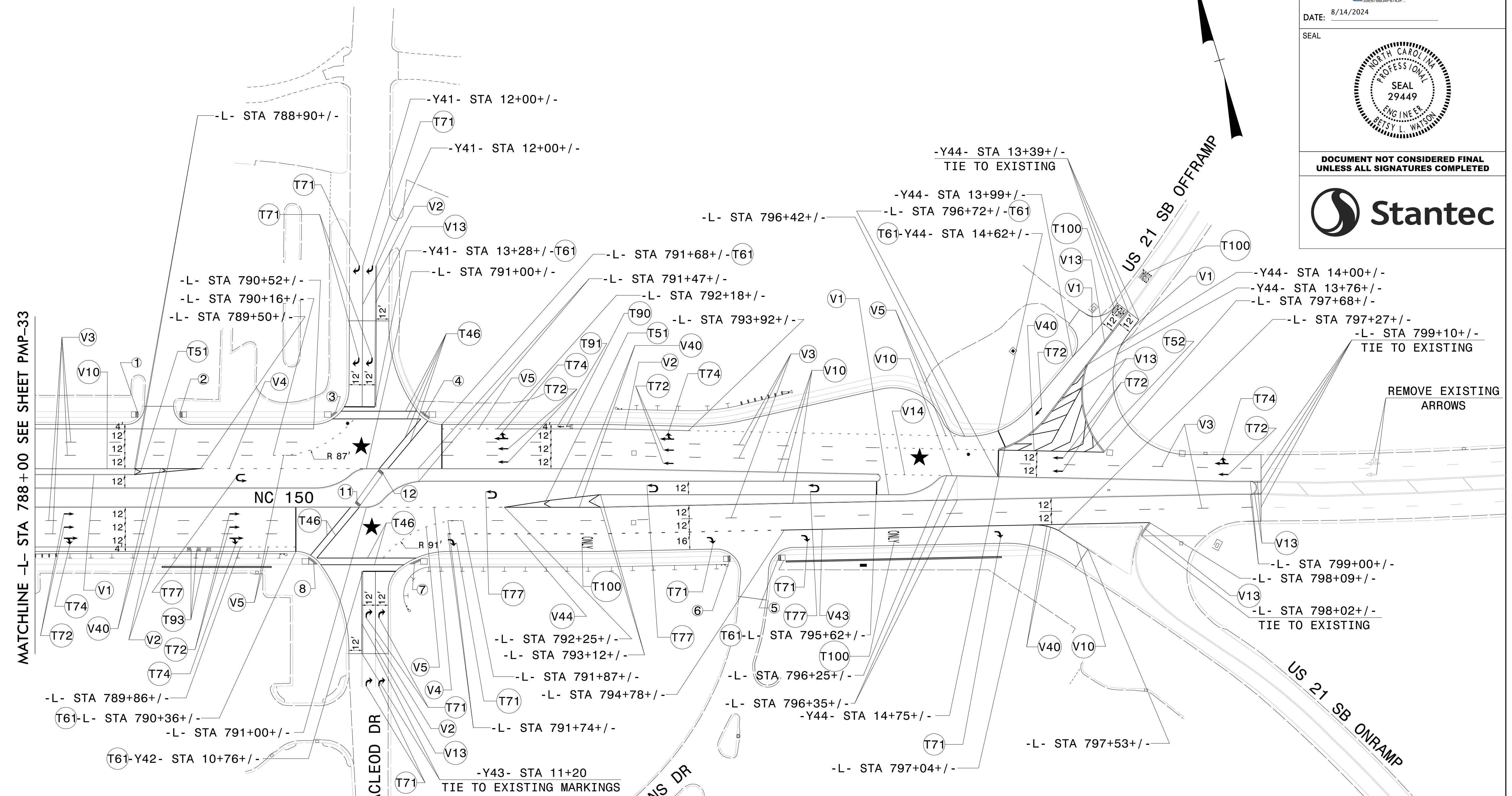

MATCHLINE -L- STA 788+00 SEE SHEET PMP-33

REMOVE EXISTING ARROWS

POLYUREA PAVEMENT MARKING LEGEND

V1	WHITE EDGELINE (4")
V2	WHITE SOLID LANE LINE (4")
V3	10 FT WHITE SKIP (4")
V4	3 FT-9 FT/SP WHITE MINISKIP (4")
V5	2 FT-6 FT/SP WHITE MINISKIP (4")
V10	YELLOW EDGELINE (4")
V13	YELLOW DOUBLE CENTER (4")
V14	2 FT-6 FT/SP YELLOW MINISKIP (4")
V40	WHITE GORELINE (8")
V43	WHITE SOLID LANE LINE (8")
V44	3 FT-9 FT/SP WHITE MINISKIP (8")

★ PROPOSED SIGNAL



THERMOPLASTIC PAVEMENT MARKING LEGEND

T46	WHITE CROSSWALK LINE (8")	T91	↑ BICYCLE STRAIGHT ARROW
T51	WHITE DIAGONAL (12")	T93	BMC BICYCLE CHARACTER
T52	YELLOW DIAGONAL (12")	T93	LANE BICYCLE CHARACTER
T61	WHITE STOPBAR (24")	T93	ENDS BICYCLE CHARACTER
T71	↷ RIGHT TURN ARROW	T94	⚠ SHARROW, HEATED-IN-PLACE
T72	↑ STRAIGHT ARROW	T100	ONLY ALPHANUMERIC CHARACTERS
T74	↷ STRAIGHT/RIGHT ARROW	T100	SIGNAL ALPHANUMERIC CHARACTERS
T77	↶ U-TURN ARROW	T100	AHEAD ALPHANUMERIC CHARACTERS
T90	⦿ BICYCLE SYMBOL		

	CURB_RAMP_STATIONS	CURB_RAMP_TYPE		CURB_RAMP_STATIONS	CURB_RAMP_TYPE
1	-L- STA 788+94+/-	TYPE 1 MODIFIED	7	-Y42- STA 10+66+/-	TYPE 1C
2	-L- STA 789+31+/-	TYPE 1 MODIFIED	8	-Y42- STA 10+65+/-	TYPE 2A MODIFIED
3	-Y41- STA 13+35+/-	TYPE 1C	9	-L- STA 790+91+/-	TYPE 1 MODIFIED
4	-Y41- STA 13+36+/-	TYPE 2A MODIFIED	10	-L- STA 791+17+/-	TYPE 1 MODIFIED
5	-L- STA 794+73+/-	TYPE 1 MODIFIED	11	-L- STA 790+92+/-	TYPE 7
6	-L- STA 794+29+/-	TYPE 1 MODIFIED	12	-L- STA 791+14+/-	TYPE 7

PAVEMENT MARKING DETAIL

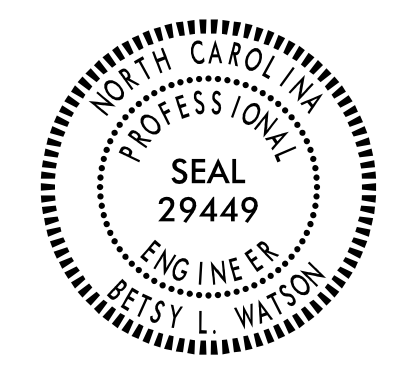
\$\$\$\$\$SYTIME\$\$\$\$\$
\$\$\$\$\$DGN\$\$\$\$\$
\$\$\$\$\$USERNAME\$\$\$\$\$

TIP NO. R-2307B & I-5717	SHEET NO. PMP-35
APPROVED: <i>Betsy L. Watson</i> <small>REGISTERED PROFESSIONAL ENGINEER</small>	
DATE: 8/14/2024	
SEAL	
	
DOCUMENT NOT CONSIDERED FINAL UNLESS ALL SIGNATURES COMPLETED	
	

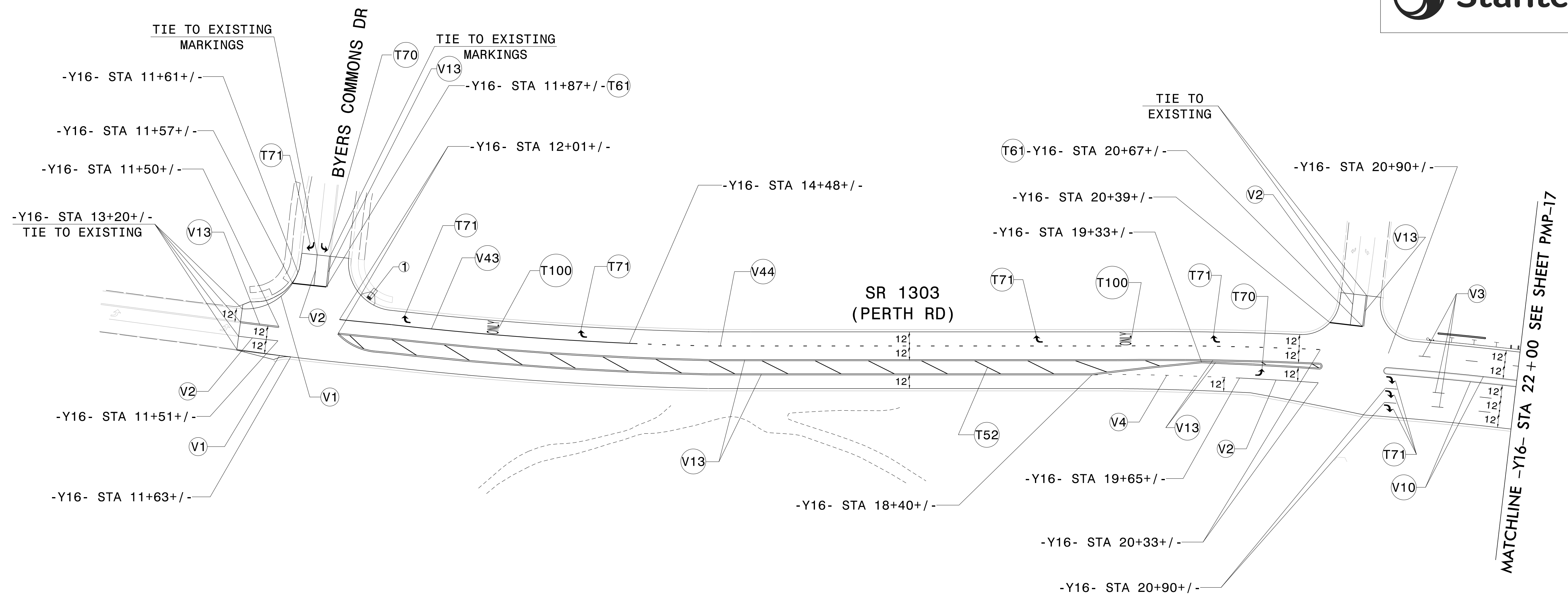
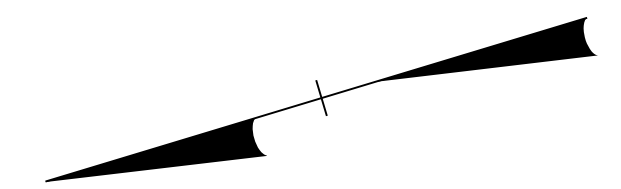

POLYUREA PAVEMENT MARKING LEGEND

V1	WHITE EDGELINE (4")
V2	WHITE SOLID LANE LINE (4")
V3	10 FT WHITE SKIP (4")
V4	3 FT-9 FT/SP WHITE MINISKIP (4")



THERMOPLASTIC PAVEMENT MARKING LEGEND

T52	YELLOW DIAGONAL (12")	T71	RIGHT TURN ARROW
T61	WHITE STOPBAR (24")	T100	ONLY ALPHANUMERIC CHARACTERS
T70	LEFT TURN ARROW		

	CURB RAMP STATIONS	CURB RAMP TYPE
1	-Y16- STA 12+24+/-	STANDARD

PAVEMENT MARKING DETAIL

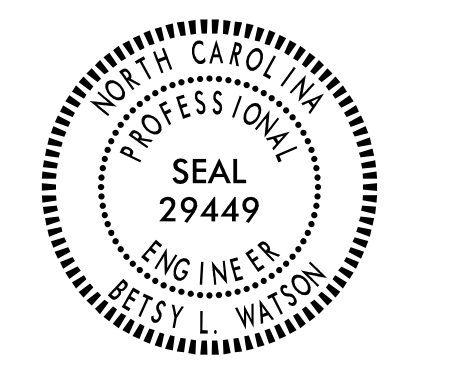
\$\$\$\$\$SYTIME\$\$\$\$\$
\$\$\$\$\$DGN\$\$\$\$\$
\$\$\$\$\$USERNAME\$\$\$\$\$

TIP NO. R-2307B & I-5717	SHEET NO. PMP-36
APPROVED: <i>Betsy L. Watson</i> <small>REGISTERED PROFESSIONAL ENGINEER</small>	
DATE: 8/14/2024	
SEAL 	
DOCUMENT NOT CONSIDERED FINAL UNLESS ALL SIGNATURES COMPLETED	
	

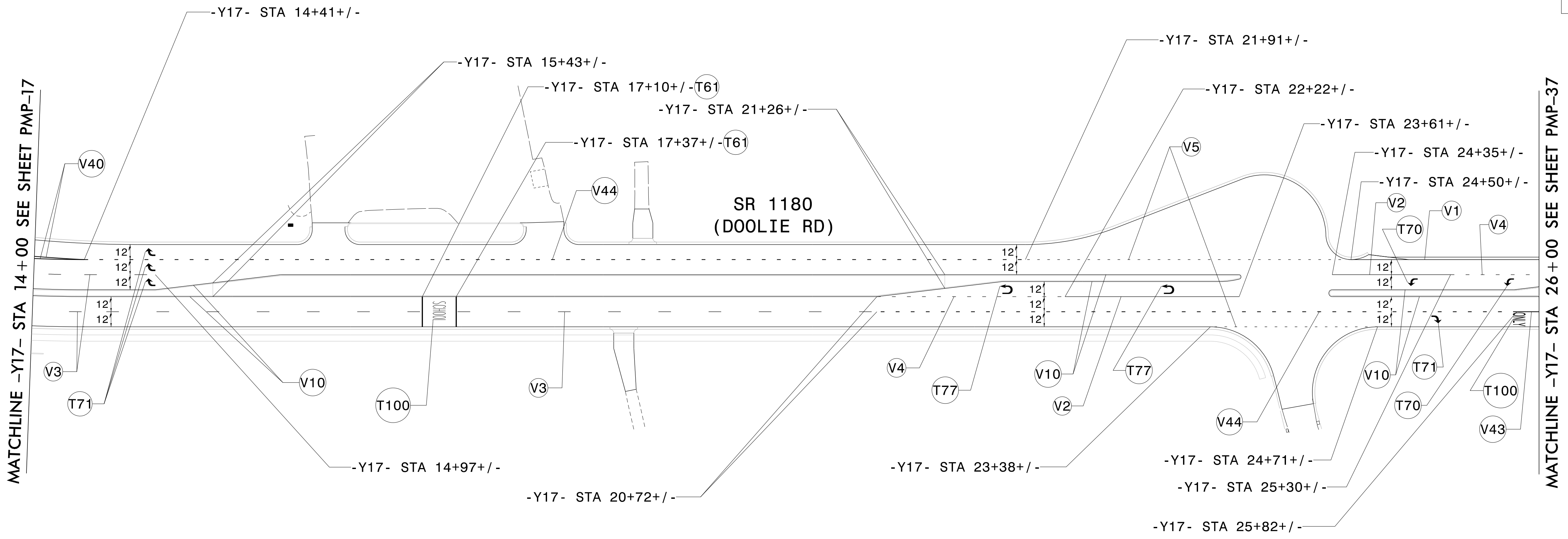
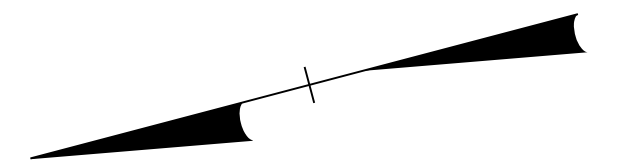



POLYUREA PAVEMENT MARKING LEGEND		
V1	WHITE EDGELINE (4")	
V2	WHITE SOLID LANE LINE (4")	
V3	10 FT WHITE SKIP (4")	
V4	3 FT-9 FT/SP WHITE MINISKIP (4")	
V5	2 FT-6 FT/SP WHITE MINISKIP (4")	
V10	YELLOW EDGELINE (4")	
V40	WHITE GORELINE (8")	
V43	WHITE SOLID LANE LINE (8")	
V44	3 FT-9 FT/SP WHITE MINISKIP (8")	

THERMOPLASTIC PAVEMENT MARKING LEGEND		
T61	WHITE STOPBAR (24")	T100 SCHOOL ALPHANUMERIC CHARACTERS
T70	LEFT TURN ARROW	
T71	RIGHT TURN ARROW	
T77	U-TURN ARROW	
T100	ONLY ALPHANUMERIC CHARACTERS	

\$\$\$\$\$SYTIME\$\$\$\$\$
\$\$\$\$\$DGN\$\$\$\$\$
\$\$\$\$\$USERNAM\$\$\$\$\$

PAVEMENT MARKING DETAIL

TIP NO. R-2307B & I-5717	SHEET NO. PMP-37
APPROVED: <i>Betsy L. Watson</i> <small>35E97B83F8743F</small>	
DATE: 8/14/2024	
SEAL	
	
DOCUMENT NOT CONSIDERED FINAL UNLESS ALL SIGNATURES COMPLETED	
	

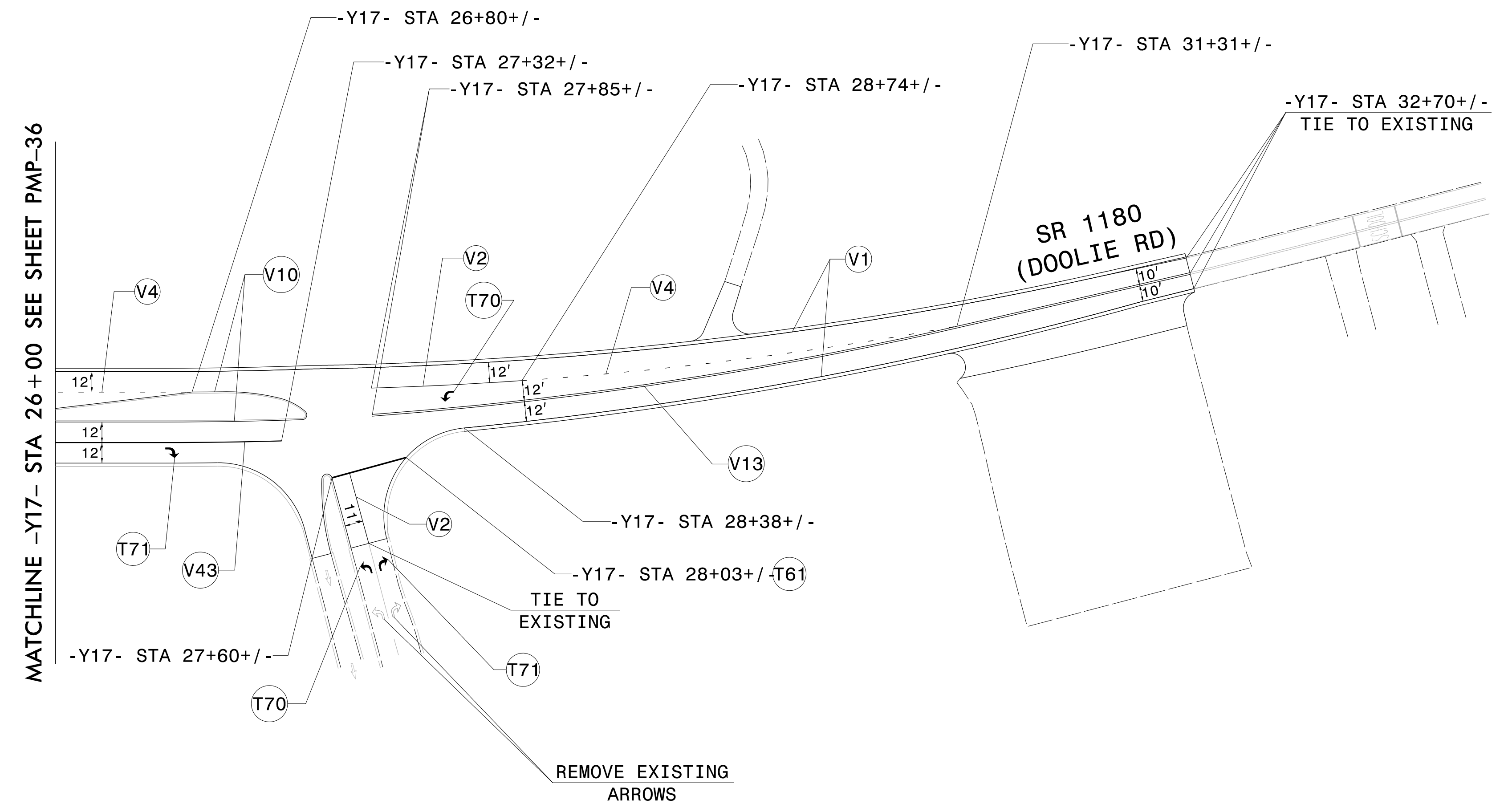
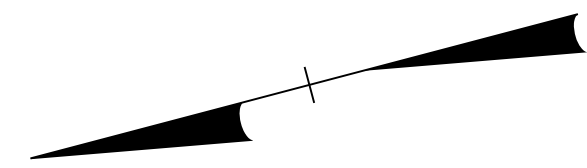



\$\$\$SYTIME\$\$\$
 \$\$\$DGN\$\$\$
 \$\$\$USERNAME\$\$\$

POLYUREA PAVEMENT MARKING LEGEND	
V1	WHITE EDGELINE (4")
V2	WHITE SOLID LANE LINE (4")
V4	3 FT-9 FT/SP WHITE MINISKIP (4")
V10	YELLOW EDGELINE (4")
V13	YELLOW DOUBLE CENTER (4")
V43	WHITE SOLID LANE LINE (8")

THERMOPLASTIC PAVEMENT MARKING LEGEND	
T6	WHITE STOPBAR (24")
T70	LEFT TURN ARROW
T71	RIGHT TURN ARROW

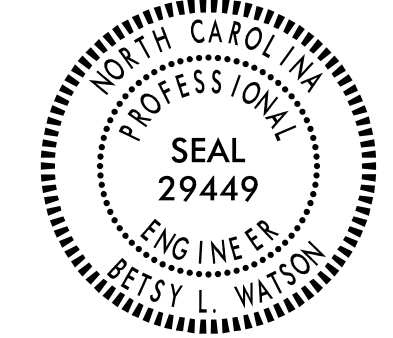
PAVEMENT MARKING DETAIL

TIP NO. R-2307B & I-5717	SHEET NO. PMP-38
APPROVED: <i>Betsy L. Watson</i>	
DATE: 8/14/2024	
SEAL	
	
DOCUMENT NOT CONSIDERED FINAL UNLESS ALL SIGNATURES COMPLETED	
	

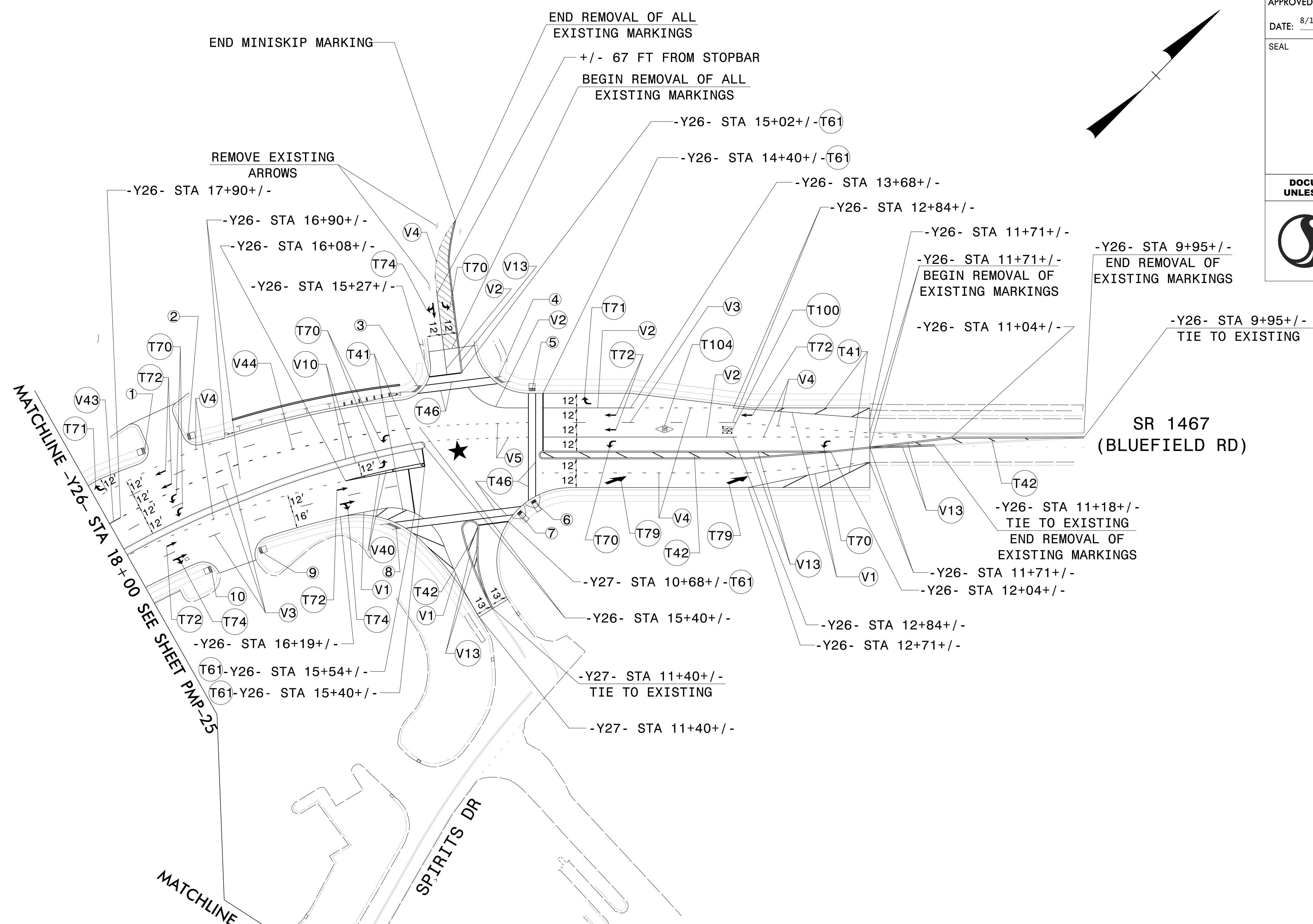

POLYUREA PAVEMENT MARKING LEGEND

(V1) WHITE EDGELINE (4")
(V2) WHITE SOLID LANE LINE (4")
(V3) 10 FT WHITE SKIP (4")
(V4) 3 FT-9 FT/SP WHITE MINISKIP (4")
(V5) 2 FT-8 FT/SP WHITE MINISKIP (4")
(V10) YELLOW EDGELINE (4")
(V13) YELLOW DOUBLE CENTER (4")
(V40) WHITE GORELINE (8")
(V43) WHITE SOLID LANE LINE (8")
(V44) 3 FT-9 FT/SP WHITE MINISKIP (8")

★ PROPOSED SIGNAL



THERMOPLASTIC PAVEMENT MARKING LEGEND

(T41) WHITE DIAGONAL (8")	(T74) STRAIGHT/RIGHT ARROW
(T42) YELLOW DIAGONAL (8")	(T79) MERGE ARROW
(T46) WHITE CROSSWALK LINE (8")	(T104) EAST ALPHANUMERIC CHARACTERS
(T61) WHITE STOPBAR (24")	(T104) ROUTE SHIELD ON DARK PAVEMENT
(T70) LEFT TURN ARROW	
(T71) RIGHT TURN ARROW	
(T72) STRAIGHT ARROW	

	CURB RAMP STATIONS	CURB RAMP TYPE
1	-Y26- STA 17+50+/-	TYPE 1 MODIFIED
2	-Y26- STA 17+16+/-	TYPE 1 MODIFIED
3	-Y26- STA 15+36+/-	TYPE 1D
4	-Y26- STA 14+75+/-	TYPE 1D
5	-Y26- STA 14+49+/-	TYPE 3 MODIFIED
6	-Y26- STA 14+49+/-	STANDARD
7	-Y27- STA 10+72+/-	STANDARD
8	-Y27- STA 10+62+/-	TYPE 1D
9	-Y26- STA 16+96+/-	TYPE 1 MODIFIED
10	-Y26- STA 17+41+/-	TYPE 1 MODIFIED

PAVEMENT MARKING DETAIL

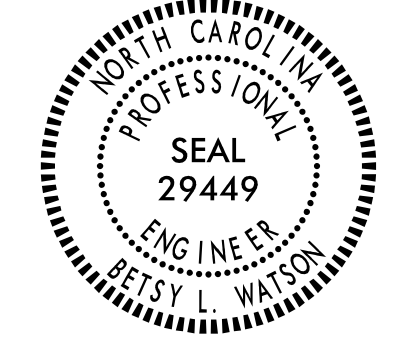
\$\$\$\$\$SYTIME\$\$\$\$\$
\$\$\$\$\$DGN\$\$\$\$\$
\$\$\$\$\$USERNAME\$\$\$\$\$

TIP NO. R-2307B & I-5717	SHEET NO. PMP-39
APPROVED: <i>Betsy L. Watson</i> <small>35E97B83F8743F</small>	
DATE: 8/14/2024	
SEAL	
	
DOCUMENT NOT CONSIDERED FINAL UNLESS ALL SIGNATURES COMPLETED	
	

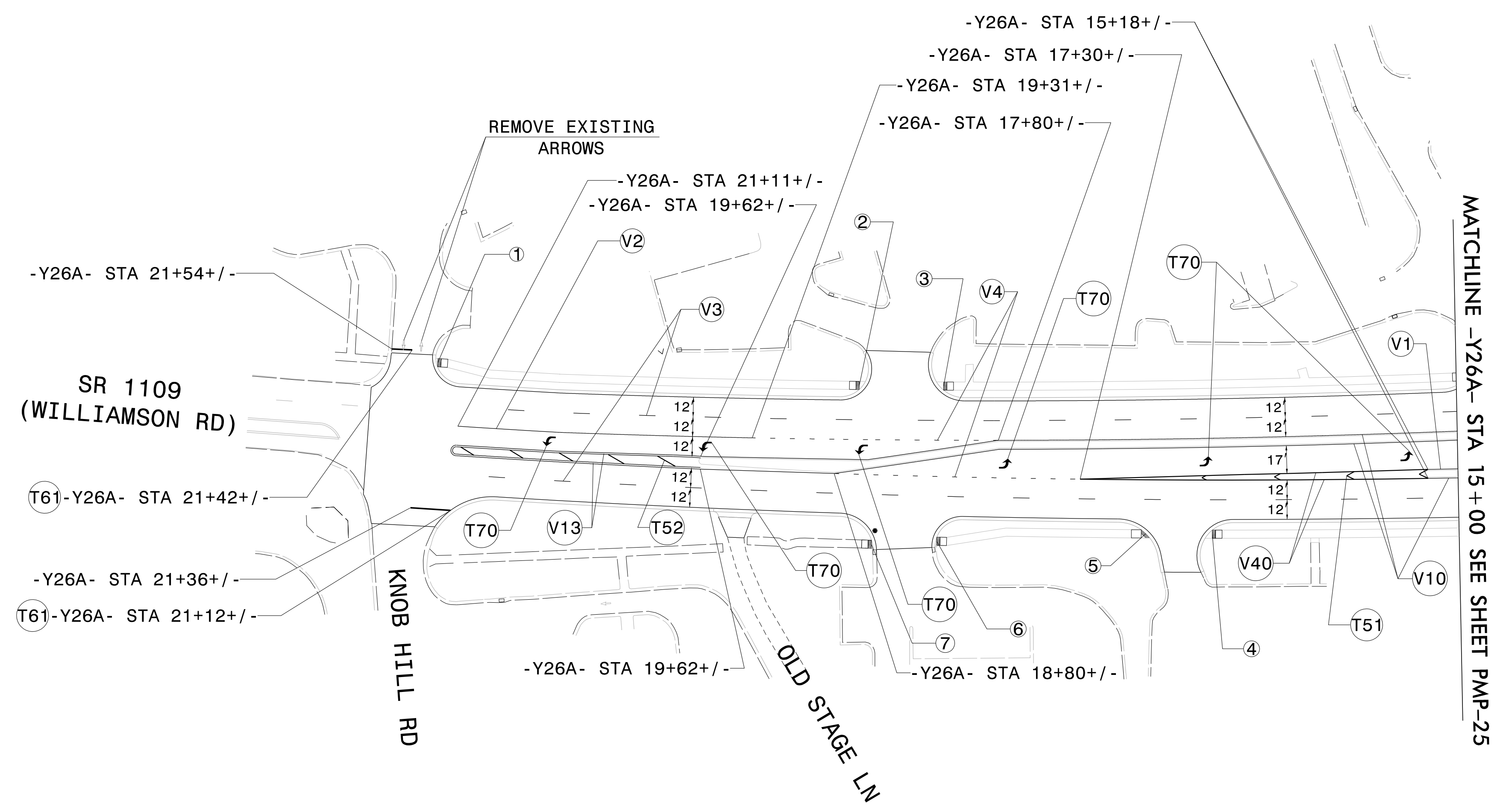
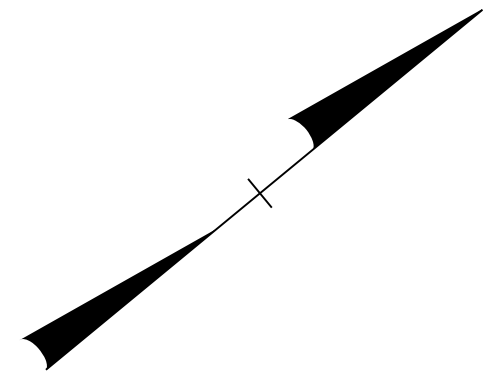



\$\$\$SYTIME\$\$\$\$
 \$\$\$DGN\$\$\$\$
 \$\$\$USERNAME\$\$\$\$

POLYUREA PAVEMENT MARKING LEGEND	
(V1)	WHITE EDGELINE (4")
(V2)	WHITE SOLID LANE LINE (4")
(V3)	10 FT WHITE SKIP (4")
(V4)	3 FT-9 FT/SP WHITE MINISKIP (4")
(V10)	YELLOW EDGELINE (4")
(V13)	YELLOW DOUBLE CENTER (4")
(V40)	WHITE GORELINE (8")

THERMOPLASTIC PAVEMENT MARKING LEGEND	
(T51)	WHITE DIAGONAL (12")
(T52)	YELLOW DIAGONAL (12")
(T61)	WHITE STOPBAR (24")
(T70)	LEFT TURN ARROW

	CURB RAMP STATIONS	CURB RAMP TYPE
(1)	-Y26A- STA 21+25+/-	TYPE 1 MODIFIED
(2)	-Y26A- STA 18+66+/-	TYPE 1 MODIFIED
(3)	-Y26A- STA 18+15+/-	TYPE 1 MODIFIED
(4)	-Y26A- STA 16+50+/-	TYPE 1 MODIFIED
(5)	-Y26A- STA 16+90+/-	TYPE 1C
(6)	-Y26A- STA 18+17+/-	TYPE 1 MODIFIED
(7)	-Y26A- STA 18+56+/-	TYPE 1 MODIFIED

PAVEMENT MARKING DETAIL

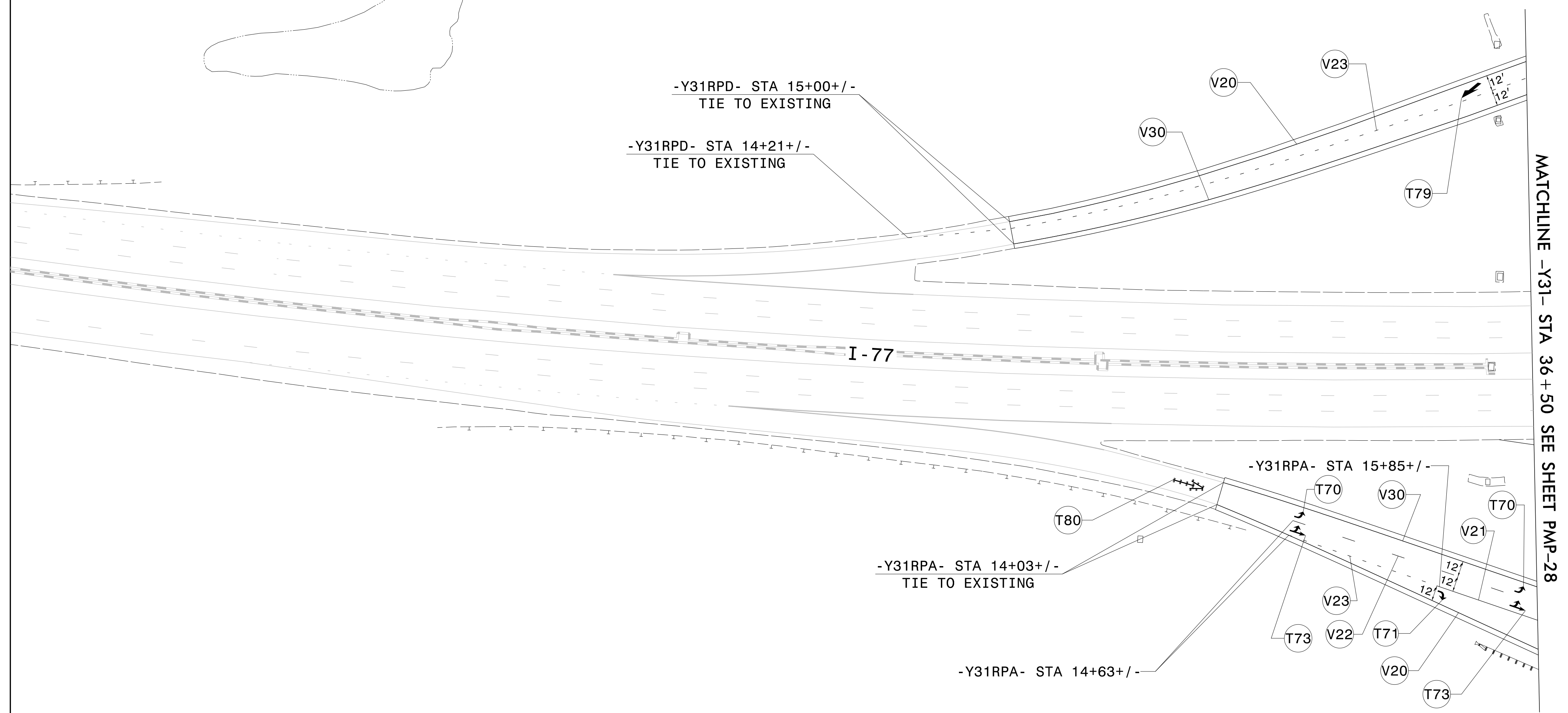
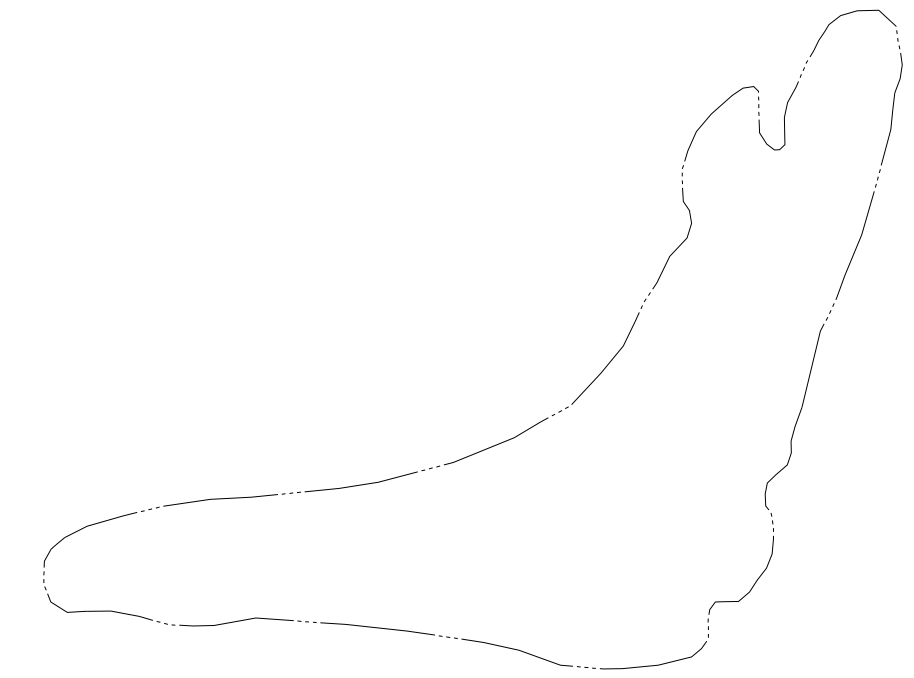
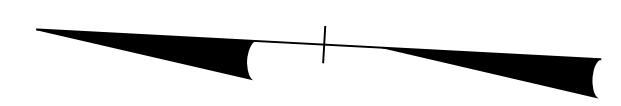

TIP NO. R-2307B & I-5717	SHEET NO. PMP-40
APPROVED: <i>Betsy L. Watson</i> <small>35E97B83F8743F</small>	
DATE: 8/14/2024	
SEAL	
	
DOCUMENT NOT CONSIDERED FINAL UNLESS ALL SIGNATURES COMPLETED	
	



\$\$\$SYTIME\$\$\$\$\$
 \$\$\$DGN\$\$\$\$\$
 \$\$\$USERNAME\$\$\$\$\$

POLYUREA PAVEMENT MARKING LEGEND	THERMOPLASTIC PAVEMENT MARKING LEGEND
WHITE EDGELINE (6")	LEFT TURN ARROW
WHITE SOLID LANE LINE (6")	RIGHT TURN ARROW
10 FT WHITE SKIP (6")	LEFT/STRAIGHT ARROW
3 FT-9 FT/SP WHITE MINISKIP (6")	MERGE ARROW
YELLOW EDGELINE (6")	RAMP ARROW SYMBOL

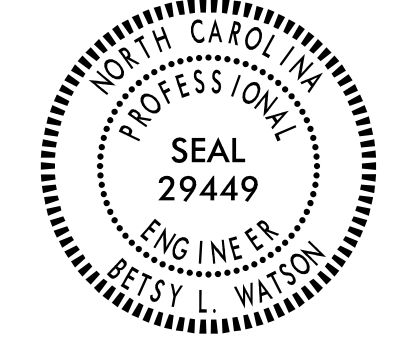
PAVEMENT MARKING DETAIL

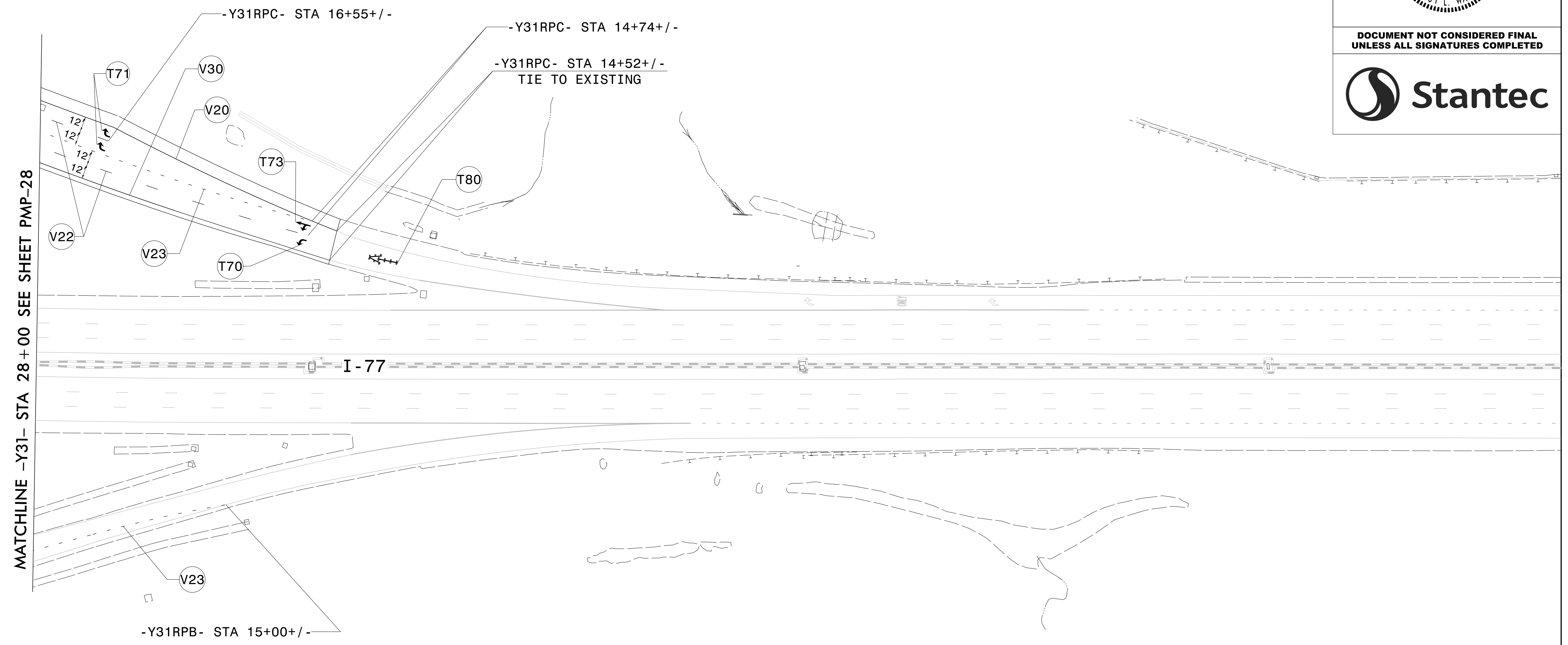
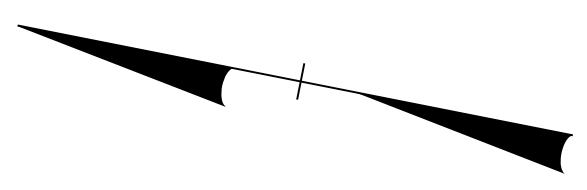

TIP NO. R-2307B & I-5717	SHEET NO. PMP-41
APPROVED: <i>Betsy L. Watson</i> <small>35E97B834F8743F</small>	
DATE: 8/14/2024	
SEAL	
	
DOCUMENT NOT CONSIDERED FINAL UNLESS ALL SIGNATURES COMPLETED	
	



\$\$\$SYTIME\$\$\$\$
 \$\$\$DGN\$\$\$\$
 \$\$\$USERNAME\$\$\$\$

POLYUREA PAVEMENT MARKING LEGEND	THERMOPLASTIC PAVEMENT MARKING LEGEND
V20 WHITE EDGELINE (6")	T70 LEFT TURN ARROW
V22 10 FT WHITE SKIP (6")	T71 RIGHT TURN ARROW
V23 3 FT-9 FT/SP WHITE MINISKIP (6")	T73 LEFT/STRAIGHT ARROW
V30 YELLOW EDGELINE (6")	T80 RAMP ARROW SYMBOL

PAVEMENT MARKING DETAIL

TIP NO. R-2307B & I-5717	SHEET NO. PMP-42
APPROVED: <i>Betsy L. Watson</i> <small>35E97B834F8743F</small>	
DATE: 8/14/2024	
SEAL	
	
DOCUMENT NOT CONSIDERED FINAL UNLESS ALL SIGNATURES COMPLETED	
	

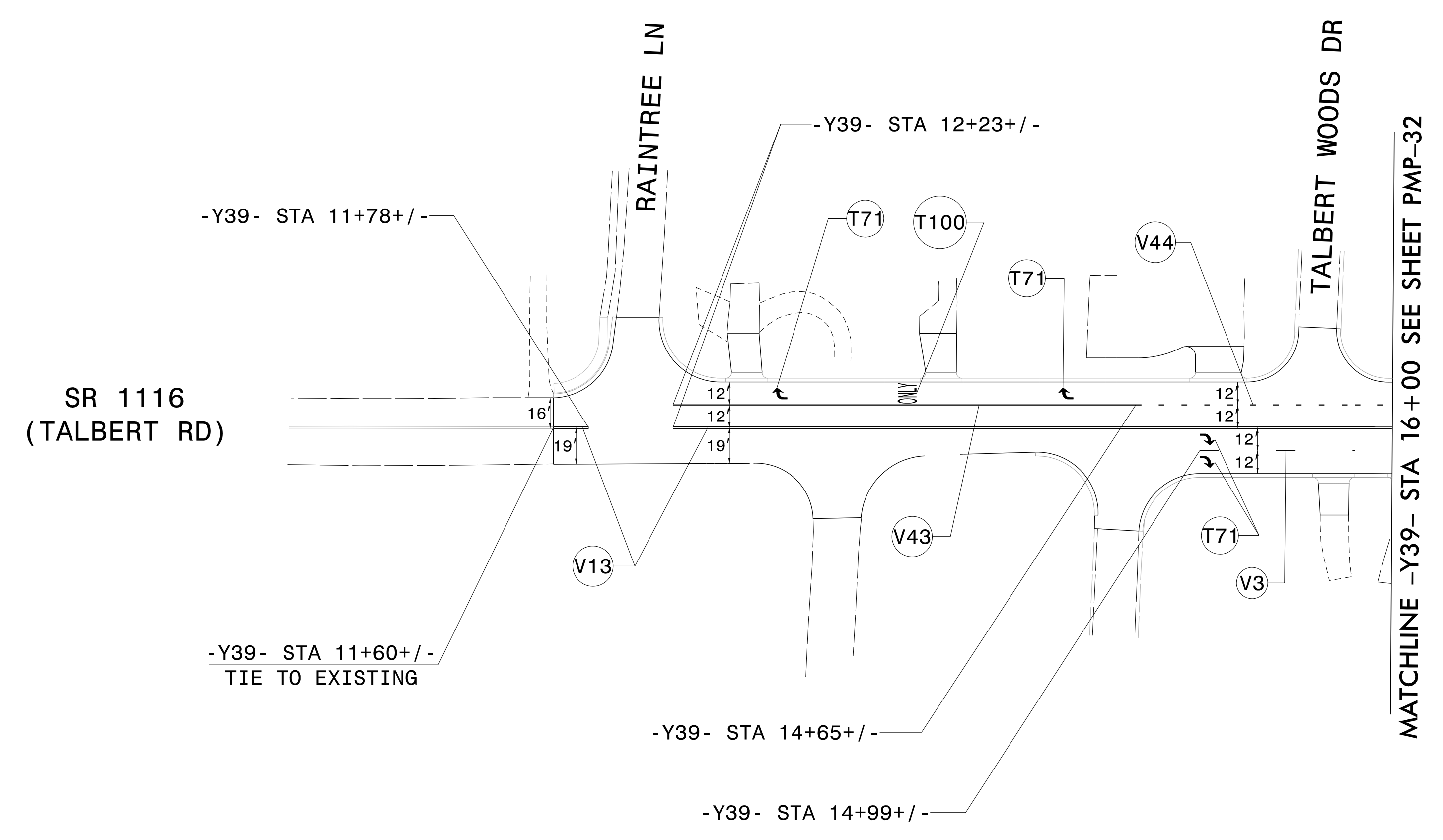
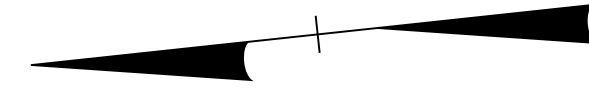

\$\$\$SYTIME\$\$\$\$
 \$\$\$DGN\$\$\$\$
 \$\$\$USERNAME\$\$\$\$

POLYUREA PAVEMENT MARKING LEGEND		THERMOPLASTIC PAVEMENT MARKING LEGEND	
(V3)	10 FT WHITE SKIP (4")	(T71)	RIGHT TURN ARROW
(V13)	YELLOW DOUBLE CENTER (4")	(T100)	ONLY ALPHANUMERIC CHARACTERS
(V43)	WHITE SOLID LANE LINE (8")		
(V44)	3 FT-9 FT/SP WHITE MINISKIP (8")		

PAVEMENT MARKING DETAIL

TIP NO. R-2307B & I-5717	SHEET NO. PMP-43
APPROVED: <i>Regina M. Muncy</i> <small>07F81B02249FA</small>	
DATE: 9/25/2024	
SEAL	
DOCUMENT NOT CONSIDERED FINAL UNLESS ALL SIGNATURES COMPLETED	

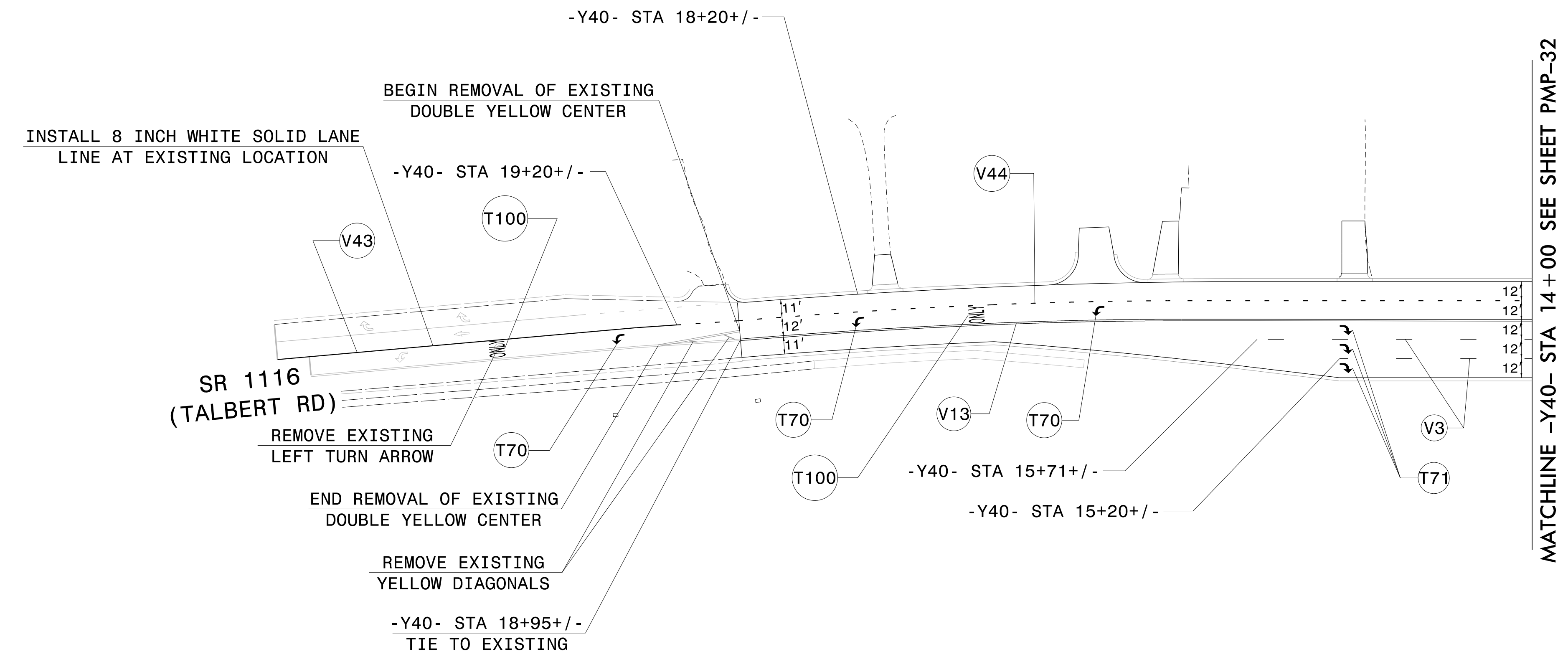
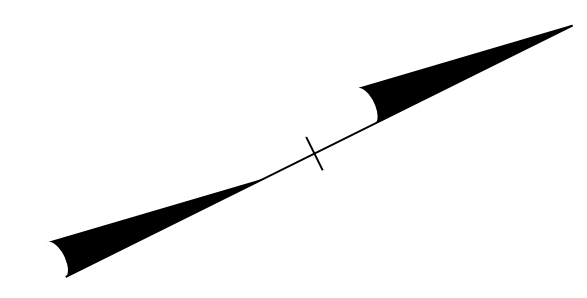

\$\$\$SYTIME\$\$\$
 \$\$\$DGN\$\$\$
 \$\$\$USERNAME\$\$\$

POLYUREA PAVEMENT MARKING LEGEND		THERMOPLASTIC PAVEMENT MARKING LEGEND	
V3	10 FT WHITE SKIP (4")	T70	LEFT TURN ARROW
V13	YELLOW DOUBLE CENTER (4")	T71	RIGHT TURN ARROW
V43	WHITE SOLID LANE LINE (8")	T100	ONLY ALPHANUMERIC CHARACTERS
V44	3 FT-9 FT/SP WHITE MINISKIP (8")		

PAVEMENT MARKING DETAIL

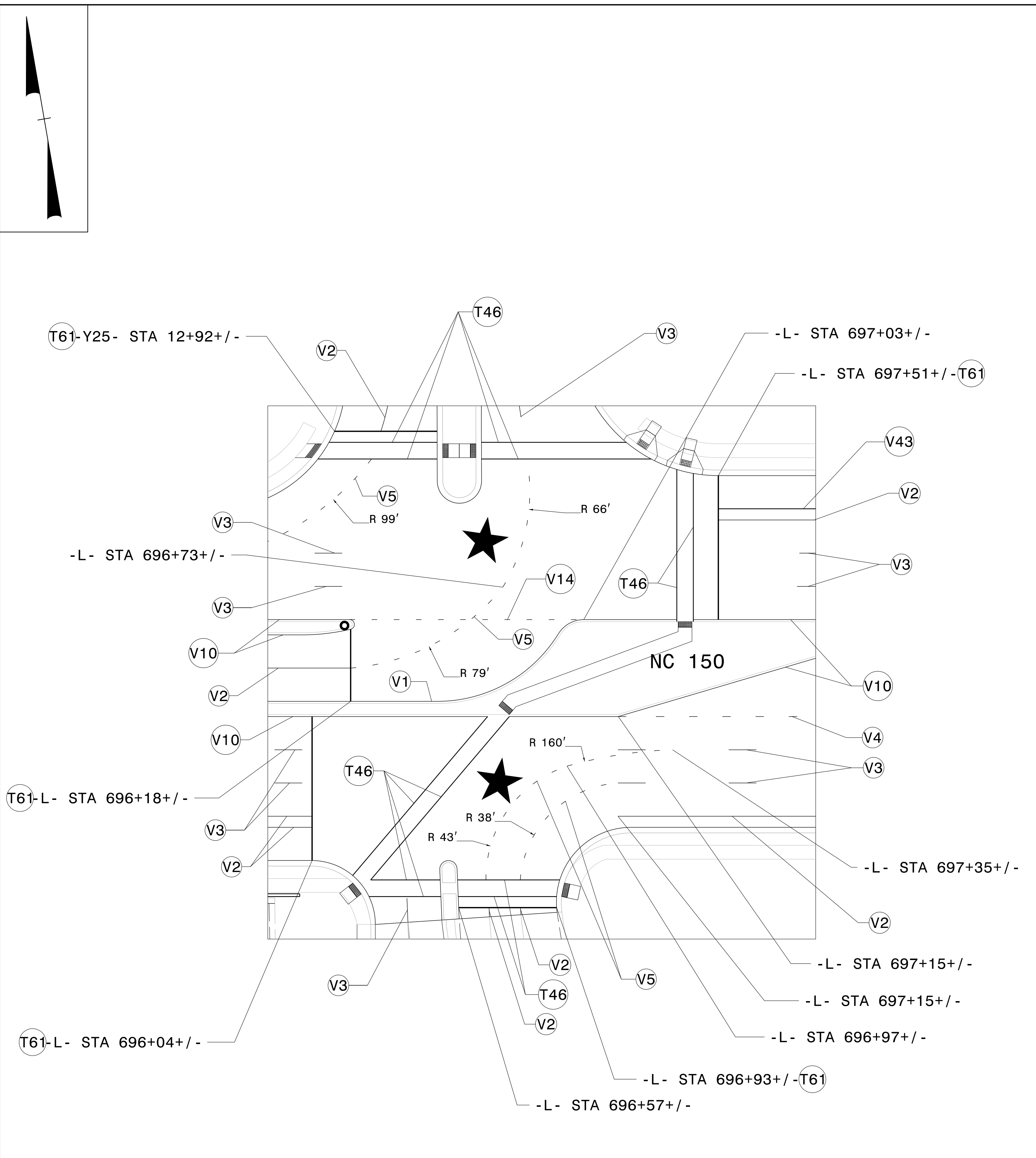

POLYUREA PAVEMENT MARKING LEGEND	
(V1)	WHITE EDGELINE (4")
(V2)	WHITE SOLID LANE LINE (4")
(V3)	10 FT WHITE SKIP (4")
(V4)	3 FT-9 FT/SP WHITE MINISKIP (4")
(V5)	2 FT-6 FT/SP WHITE MINISKIP (4")
(V10)	YELLOW EDGELINE (4")
(V14)	2 FT-6 FT/SP YELLOW MINISKIP (4")
(V43)	WHITE SOLID LANE LINE (8")

THERMOPLASTIC PAVEMENT MARKING LEGEND	
(T46)	WHITE CROSSWALK LINE (8")
(T6)	WHITE STOPBAR (24")

INSET A

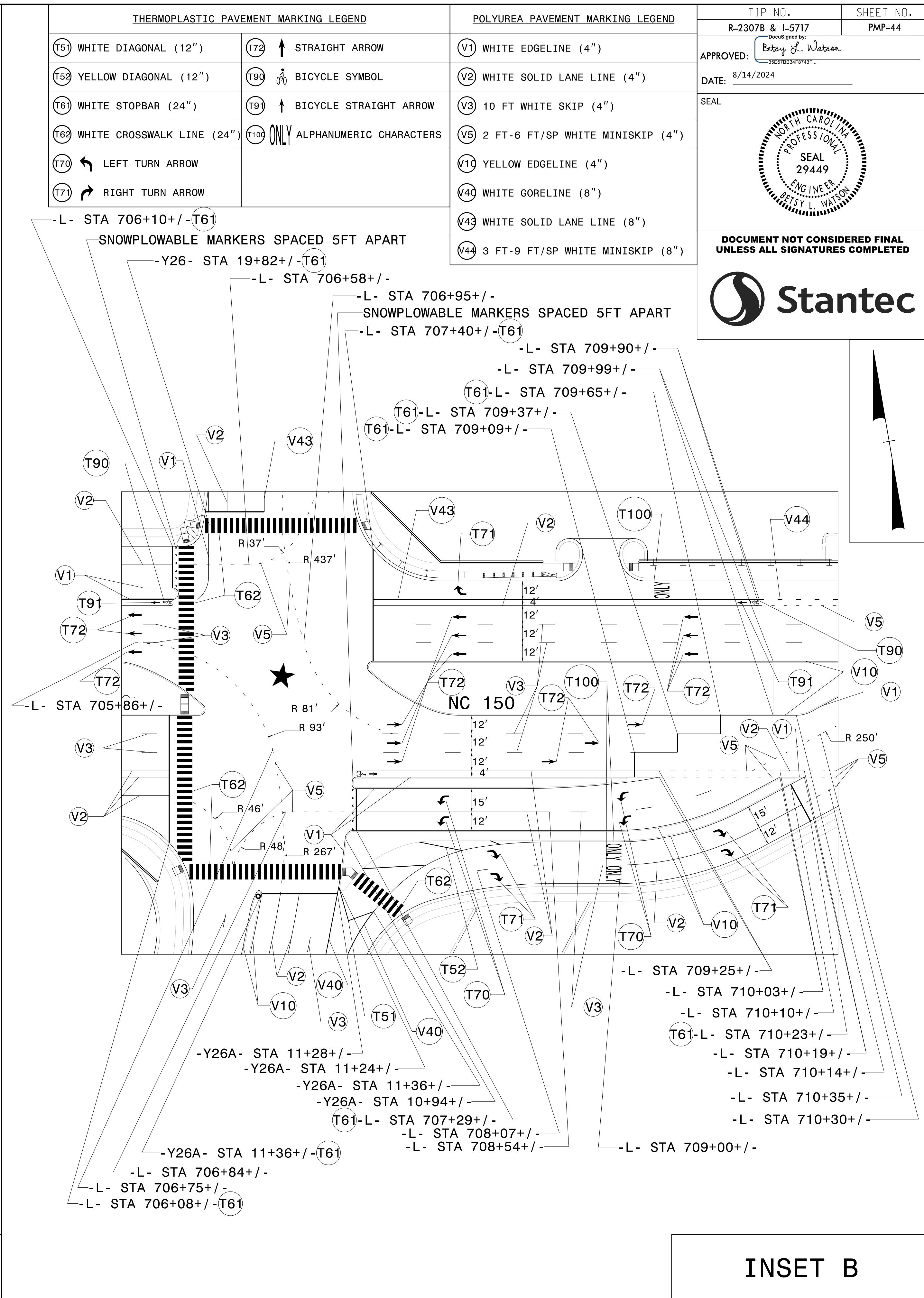

THERMOPLASTIC PAVEMENT MARKING LEGEND	
(T5)	WHITE DIAGONAL (12")
(T52)	YELLOW DIAGONAL (12")
(T6)	WHITE STOPBAR (24")
(T62)	WHITE CROSSWALK LINE (24")
(T70)	LEFT TURN ARROW
(T71)	RIGHT TURN ARROW
(T72)	↑ STRAIGHT ARROW
(T90)	♫ BICYCLE SYMBOL
(T91)	↑ BICYCLE STRAIGHT ARROW
(T100)	ONLY ALPHANUMERIC CHARACTERS

POLYUREA PAVEMENT MARKING LEGEND	
(V1)	WHITE EDGELINE (4")
(V2)	WHITE SOLID LANE LINE (4")
(V3)	10 FT WHITE SKIP (4")
(V5)	2 FT-6 FT/SP WHITE MINISKIP (4")
(V10)	YELLOW EDGELINE (4")
(V41)	WHITE GORELINE (8")
(V43)	WHITE SOLID LANE LINE (8")
(V44)	3 FT-9 FT/SP WHITE MINISKIP (8")

TIP NO. R-2307B & I-5717	SHEET NO. PMP-44
APPROVED: <i>Betsy L. Watson</i>	
DATE: 8/14/2024	
SEAL	
DOCUMENT NOT CONSIDERED FINAL UNLESS ALL SIGNATURES COMPLETED	



\$\$\$\$\$SYTIME\$\$\$\$\$
\$\$\$\$\$DDGN\$\$\$\$\$
\$\$\$\$\$USERNAME\$\$\$\$\$

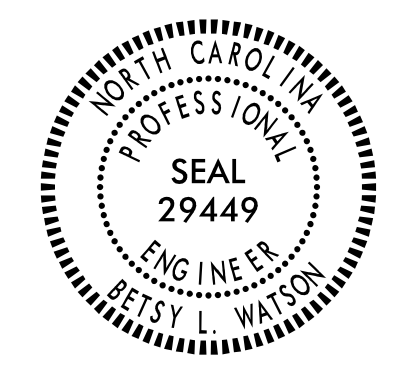

DOCUMENT NOT CONSIDERED FINAL
UNLESS ALL SIGNATURES COMPLETED

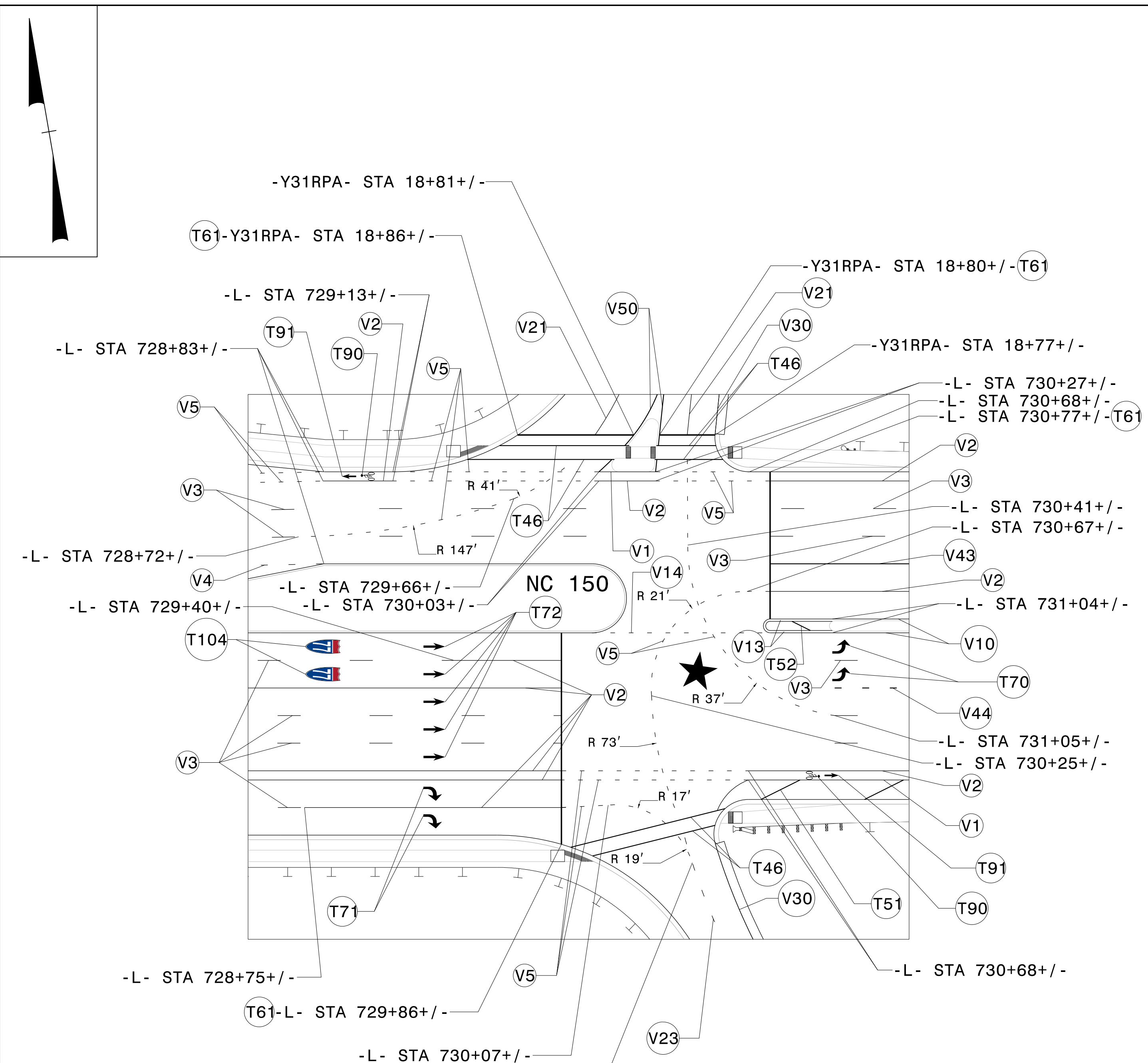

POLYUREA PAVEMENT MARKING LEGEND	
(V1)	WHITE EDGELINE (4")
(V2)	WHITE SOLID LANE LINE (4")
(V3)	10 FT WHITE SKIP (4")
(V4)	3 FT-9 FT/SP WHITE MINISKIP (4")
(V5)	2 FT-6 FT/SP WHITE MINISKIP (4")
(V10)	YELLOW EDGELINE (4")
(V13)	YELLOW DOUBLE CENTER (4")
(V14)	2 FT-6 FT/SP YELLOW MINISKIP (4")
(V21)	WHITE SOLID LANE LINE (6")
(V23)	3 FT-9 FT/SP WHITE MINISKIP (6")
(V30)	YELLOW EDGELINE (6")
(V43)	WHITE SOLID LANE LINE (8")
(V44)	3 FT-9 FT/SP WHITE MINISKIP (8")
(V50)	WHITE GORELINE (12")

THERMOPLASTIC PAVEMENT MARKING LEGEND	
(T46)	WHITE CROSSWALK LINE (8")
(T51)	WHITE DIAGONAL (12")
(T52)	YELLOW DIAGONAL (12")
(T61)	WHITE STOPBAR (24")
(T70)	LEFT TURN ARROW
(T71)	RIGHT TURN ARROW
(T72)	↑ STRAIGHT ARROW
(T90)	🚲 BICYCLE SYMBOL
(T91)	↑ BICYCLE STRAIGHT ARROW
(T104)	🛡️ ROUTE SHIELD ON DARK PAVEMENT

INSET C

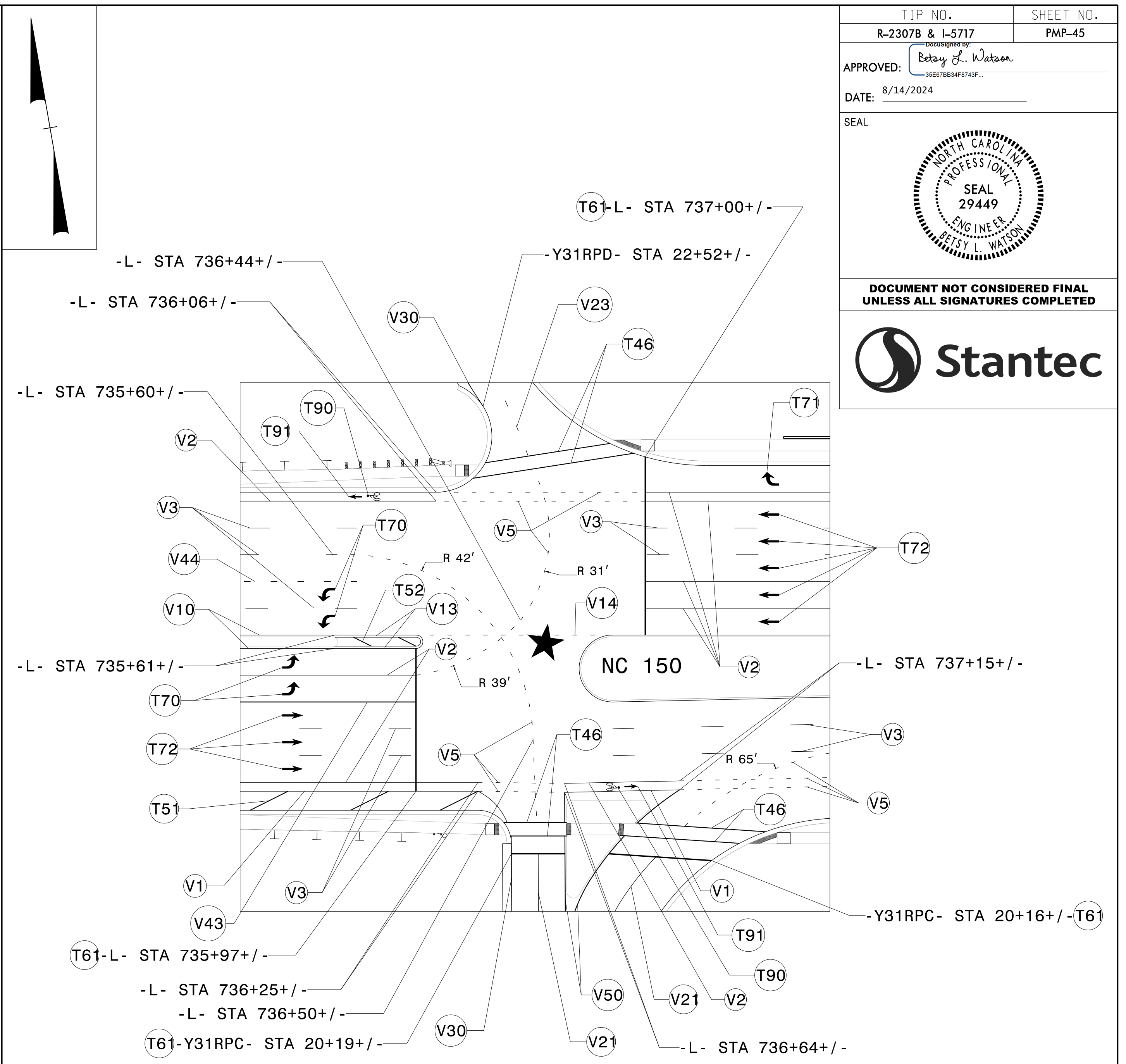

POLYUREA PAVEMENT MARKING LEGEND	
(V1)	WHITE EDGELINE (4")
(V2)	WHITE SOLID LANE LINE (4")
(V3)	10 FT WHITE SKIP (4")
(V5)	2 FT-6 FT/SP WHITE MINISKIP (4")
(V10)	YELLOW EDGELINE (4")
(V13)	YELLOW DOUBLE CENTER (4")
(V14)	2 FT-6 FT/SP YELLOW MINISKIP (4")
(V21)	WHITE SOLID LANE LINE (6")
(V23)	3 FT-9 FT/SP WHITE MINISKIP (6")
(V30)	YELLOW EDGELINE (6")
(V43)	WHITE SOLID LANE LINE (8")
(V44)	3 FT-9 FT/SP WHITE MINISKIP (8")
(V50)	WHITE GORELINE (12")

THERMOPLASTIC PAVEMENT MARKING LEGEND	
(T46)	WHITE CROSSWALK LINE (8")
(T51)	WHITE DIAGONAL (12")
(T52)	YELLOW DIAGONAL (12")
(T61)	WHITE STOPBAR (24")
(T70)	LEFT TURN ARROW
(T71)	↷ RIGHT TURN ARROW
(T72)	↑ STRAIGHT ARROW
(T90)	🚲 BICYCLE SYMBOL
(T91)	↑ BICYCLE STRAIGHT ARROW

INSET D

\$\$\$\$SYTIME\$\$\$\$
\$\$\$\$DGN\$\$\$\$
\$\$\$\$USERNAME\$\$\$\$