

WEDGE EXISTING AS NECESSARY IN ORDER TO MAINTAIN TRAFFIC AND CONSTRUCT IN A MANNER SUCH THAT NO PONDING OF WATER IN THE TRAVEL LANES OCCURS

MATCH LINE SHEET TMP-24  
-L- STA. 665+00

MATCH LINE SHEET TMP-26  
-L- STA. 678+00

-L- NC 150 RIVER HWY

6/4/2024  
 U:\Traffic\Transportation Management\Plan\TCP\PLAN SHEETS\IR-2307B-TMP-25\_PHASE\_01\_STEP\_01.dgn  
 dorichardson

PROPOSE TEMPOR.  
PEDEST.  
CROSSWALK HE



Stantec Consulting Services Inc.  
801 Jones Franklin Road  
Suite 300  
Raleigh, NC 27606  
Tel. 919.851.6866  
Fax. 919.851.7024  
www.stantec.com  
License No. F-0672

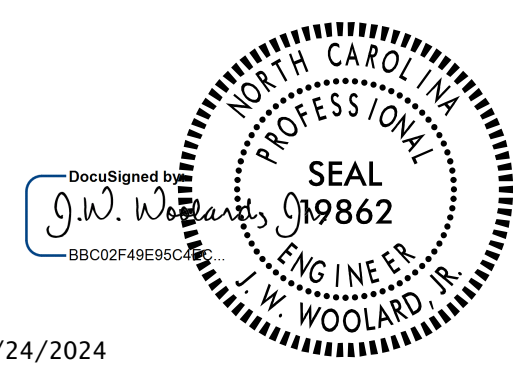

7/24/2024

**DOCUMENT NOT CONSIDERED FINAL  
UNLESS ALL SIGNATURES COMPLETED**

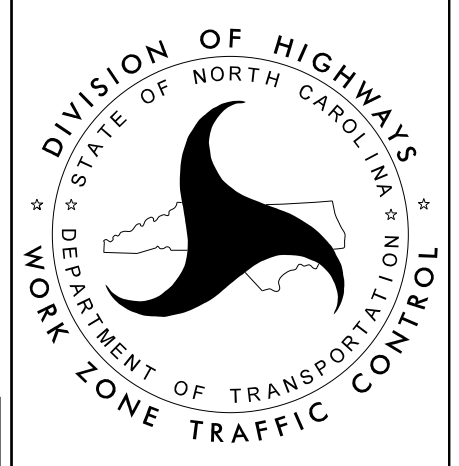

-L- NC 150  
PHASE I  
STEP 1

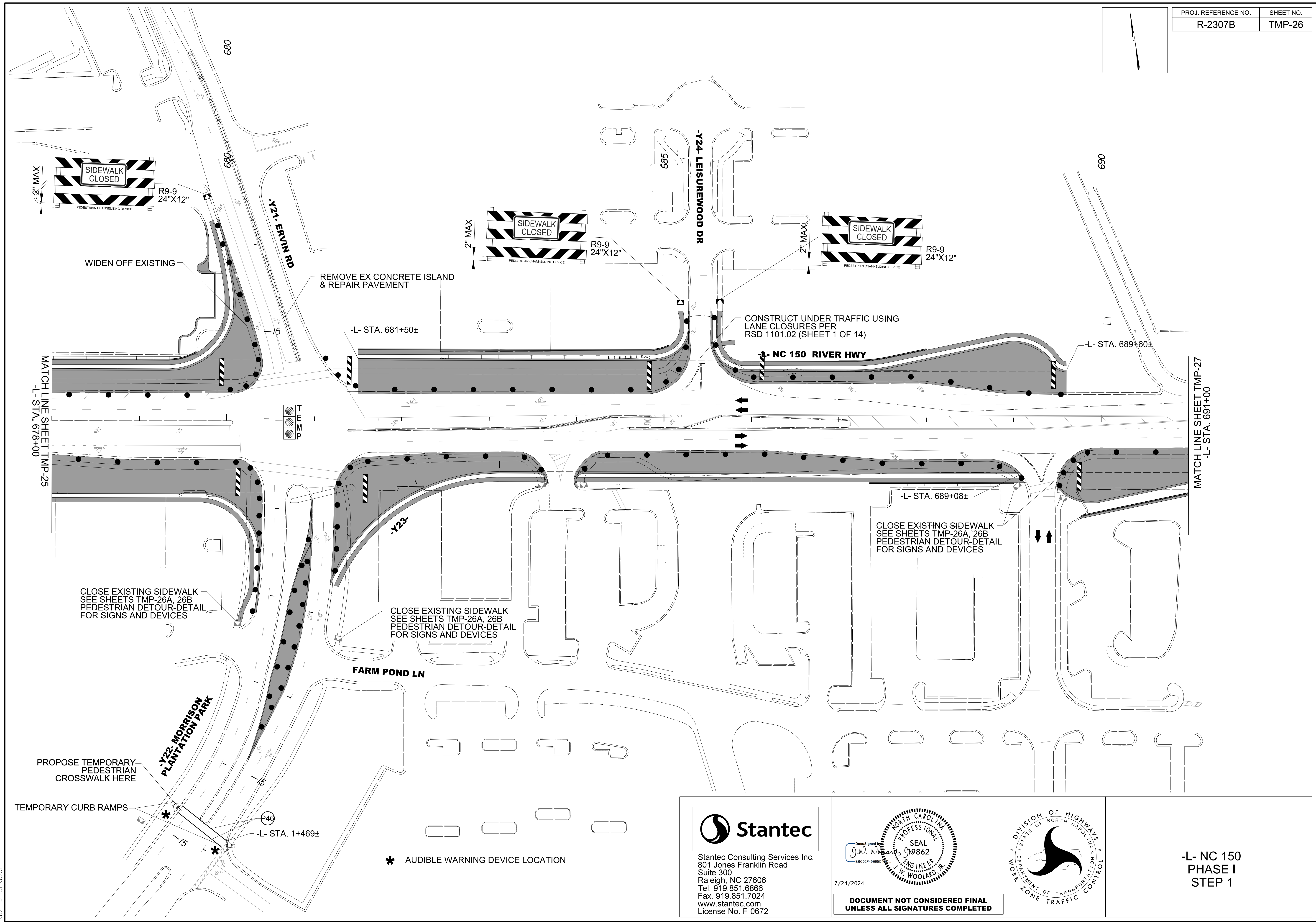
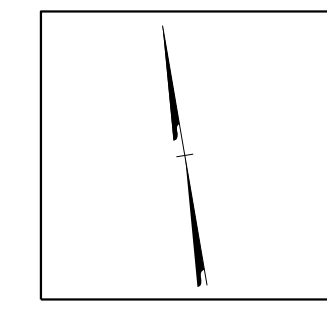

6/4/2024  
 U:\Traffic\Transportation Management\Plan\TCP\PLAN SHEETS\VR-2307B-TMP-26\_PHASE-01-STEP\_0.dgn  
 dorichardson

**Stantec**

Stantec Consulting Services Inc.  
 801 Jones Franklin Road  
 Suite 300  
 Raleigh, NC 27606  
 Tel. 919.851.6866  
 Fax. 919.851.7024  
 www.stantec.com  
 License No. F-0672

7/24/2024

Seal: J.W. Woolard, P.E., License No. 919862

DOCUMENT NOT CONSIDERED FINAL UNLESS ALL SIGNATURES COMPLETED

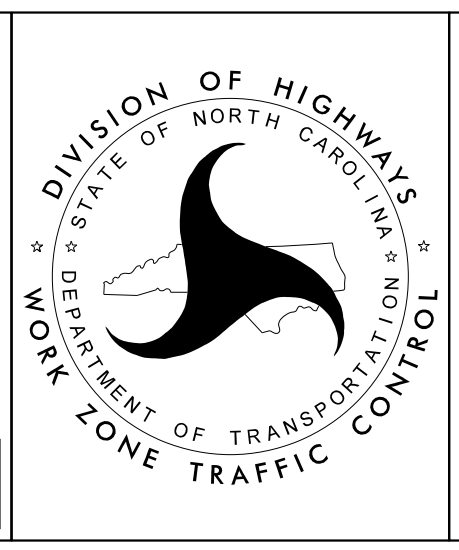

-L- NC 150  
 PHASE I  
 STEP 1

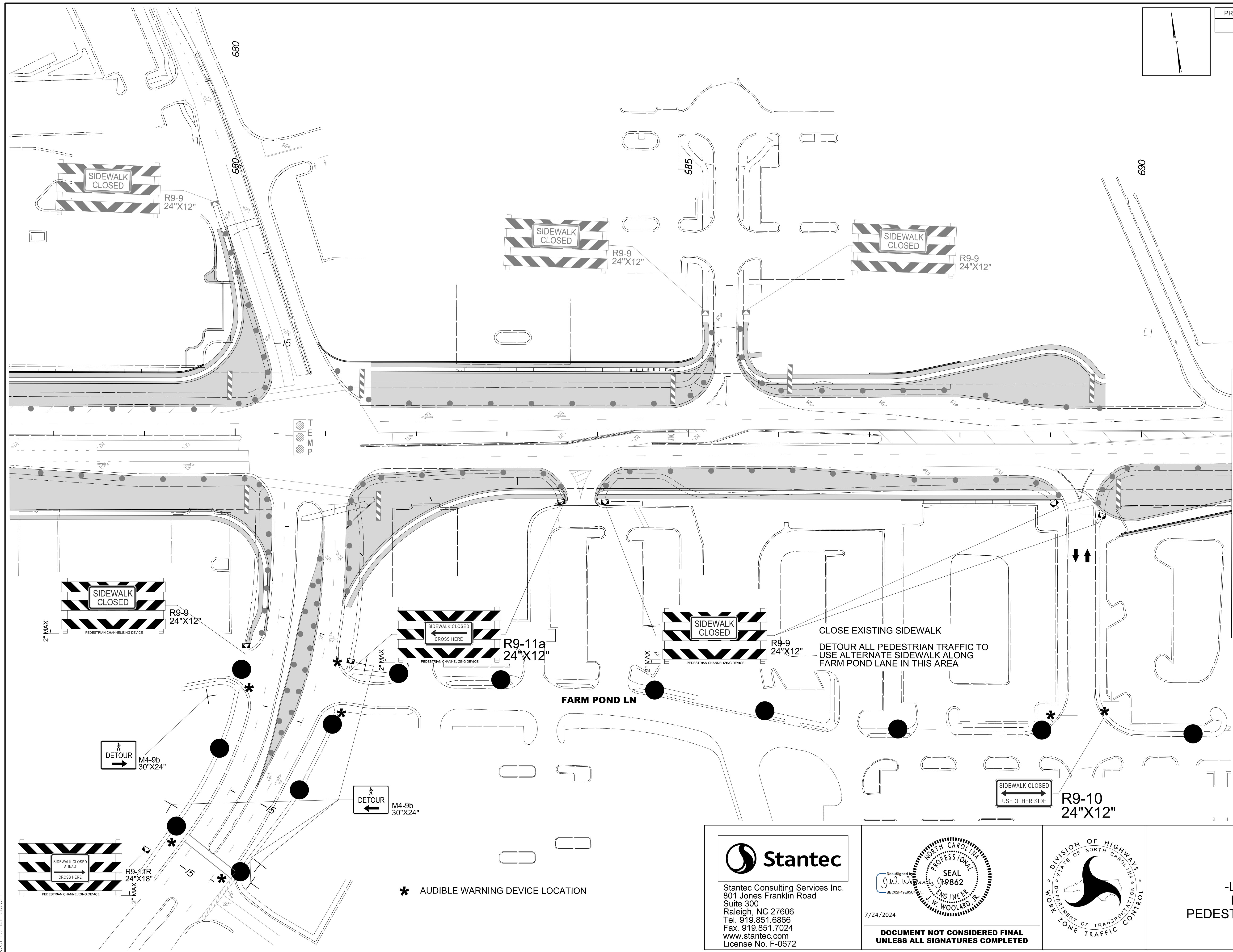
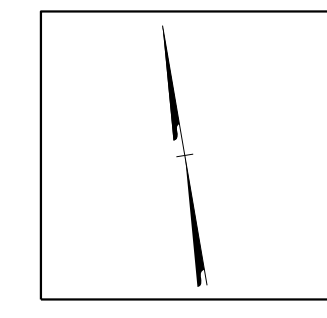

MATCH LINE SHEET TMP-26B  
-L- STA. 691+00

6/4/2024  
L:\Traffic\Transportation Management Plan\TCP\PLAN SHEETS\VR-2307B-TMP-26A-PHASE-01-STEP-01-PED-DETOUR.dgn  
dorichardson

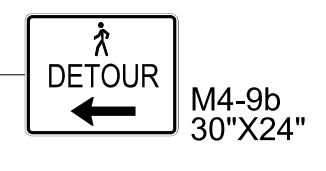
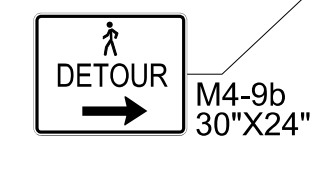
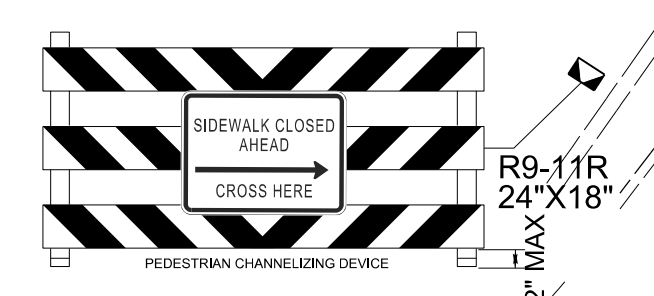

\* AUDIBLE WARNING DEVICE LOCATION

CLOSE EXISTING SIDEWALK  
DETOUR ALL PEDESTRIAN TRAFFIC TO  
USE ALTERNATE SIDEWALK ALONG  
FARM POND LANE IN THIS AREA

**Stantec**  
Stantec Consulting Services Inc.  
801 Jones Franklin Road  
Suite 300  
Raleigh, NC 27606  
Tel. 919.851.6866  
Fax. 919.851.7024  
www.stantec.com  
License No. F-0672

7/24/2024

**DOCUMENT NOT CONSIDERED FINAL  
UNLESS ALL SIGNATURES COMPLETED**

DIVISION OF HIGHWAYS  
STATE OF NORTH CAROLINA  
DEPARTMENT OF TRANSPORTATION  
WORK ZONE TRAFFIC CONTROL

-L- NC 150  
PHASE I  
PEDESTRIAN DETOUR

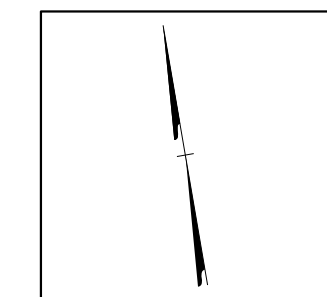

MATCH LINE SHEET TMP-26A  
-L- STA. 691+00

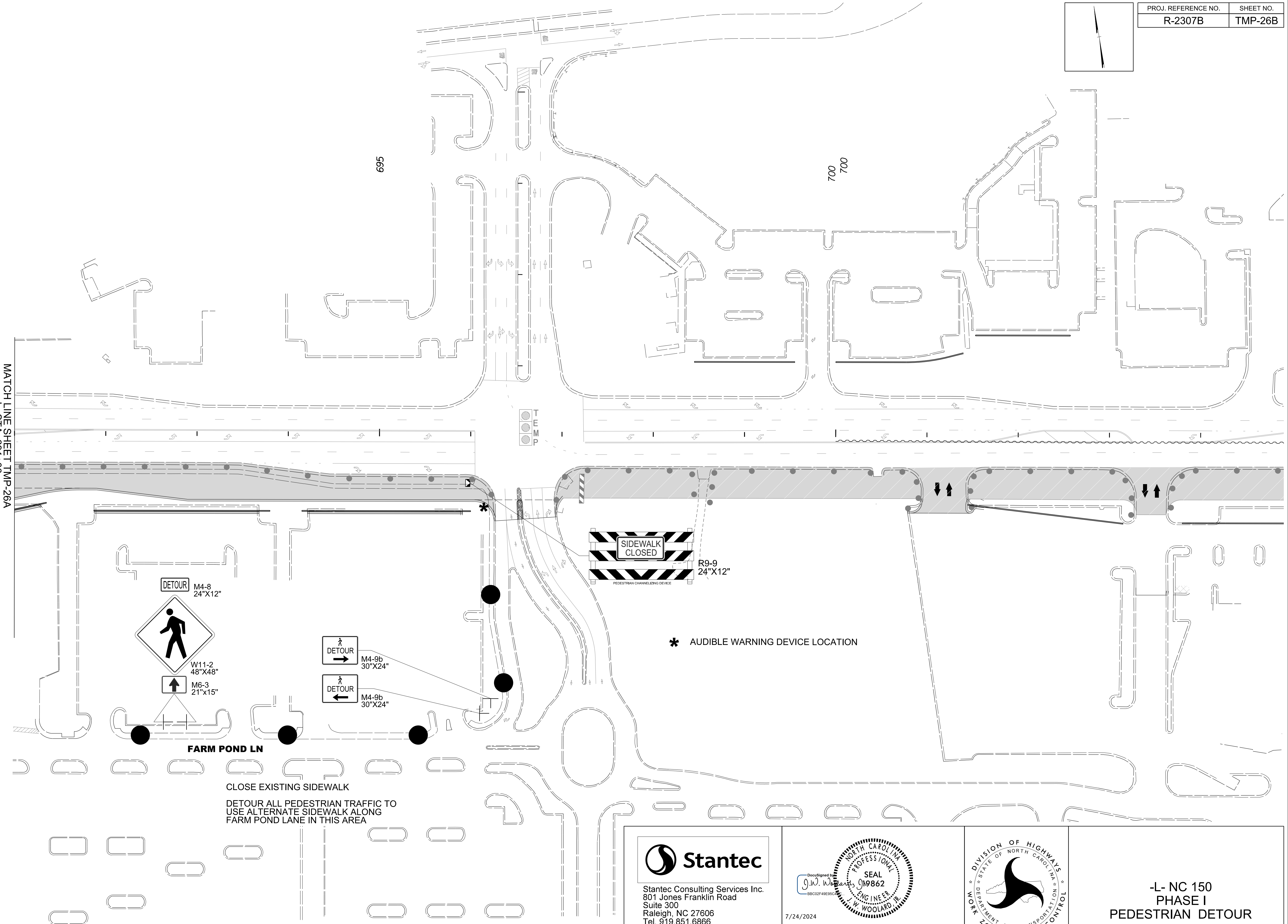

DETOUR M4-8  
24"x12"



W11-2  
48"x48"

M6-3  
21"x15"

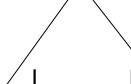

DETOUR M4-9b  
30"x24"

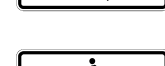

DETOUR M4-9b  
30"x24"



R9-9  
24"x12"

\* AUDIBLE WARNING DEVICE LOCATION

FARM POND LN

CLOSE EXISTING SIDEWALK  
DETOUR ALL PEDESTRIAN TRAFFIC TO  
USE ALTERNATE SIDEWALK ALONG  
FARM POND LANE IN THIS AREA

6/4/2024  
L:\Traffic\Transportation Management Plan\TCP\PLAN SHEETS\VR-2307B-TMP-26B-PHASE-01-STEP-01-PED-DETOUR.dgn  
dorichardson

**Stantec**  
 Stantec Consulting Services Inc.  
 801 Jones Franklin Road  
 Suite 300  
 Raleigh, NC 27606  
 Tel. 919.851.6866  
 Fax. 919.851.7024  
 www.stantec.com  
 License No. F-0672

DocuSigned by  
 J.W. Woolard  
 7/24/2024  
 NORTH CAROLINA  
 PROFESSIONAL  
 SEAL  
 19862  
 ENGINEER  
 J. W. WOOLARD, P.E.

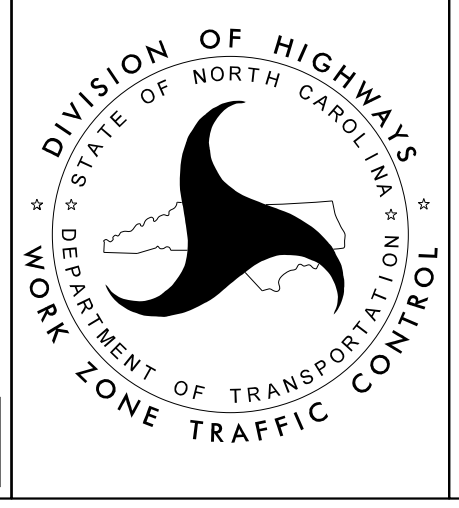

-L- NC 150  
PHASE I  
PEDESTRIAN DETOUR

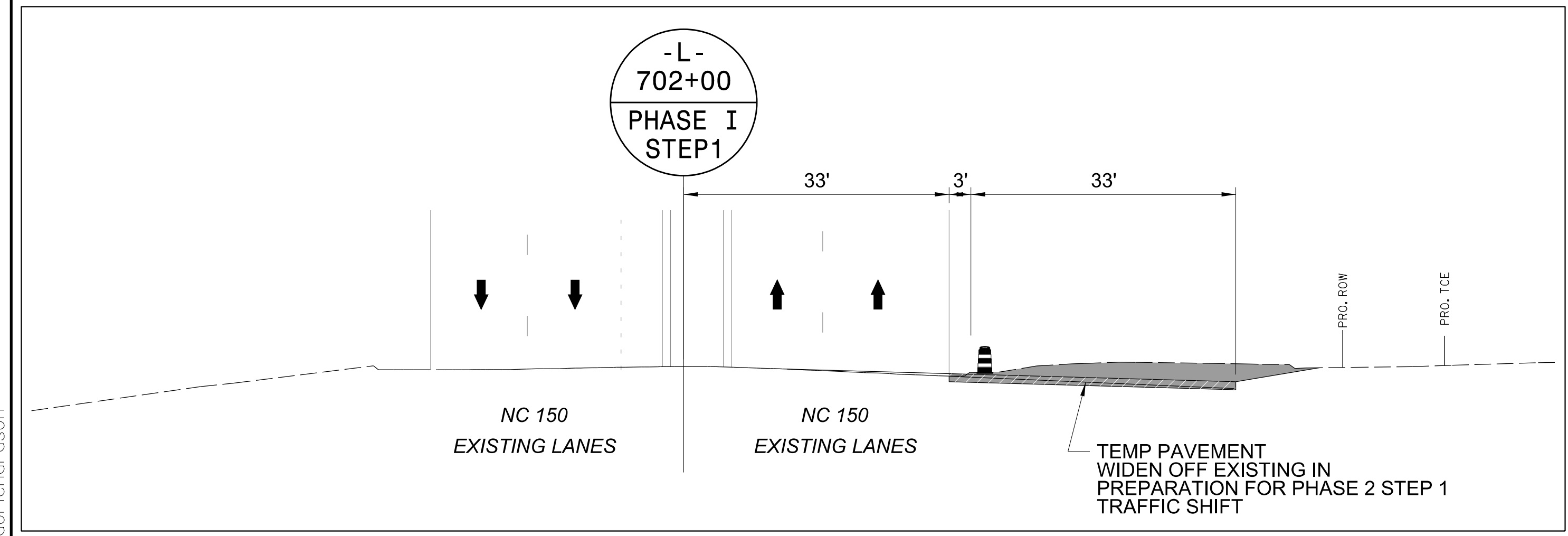
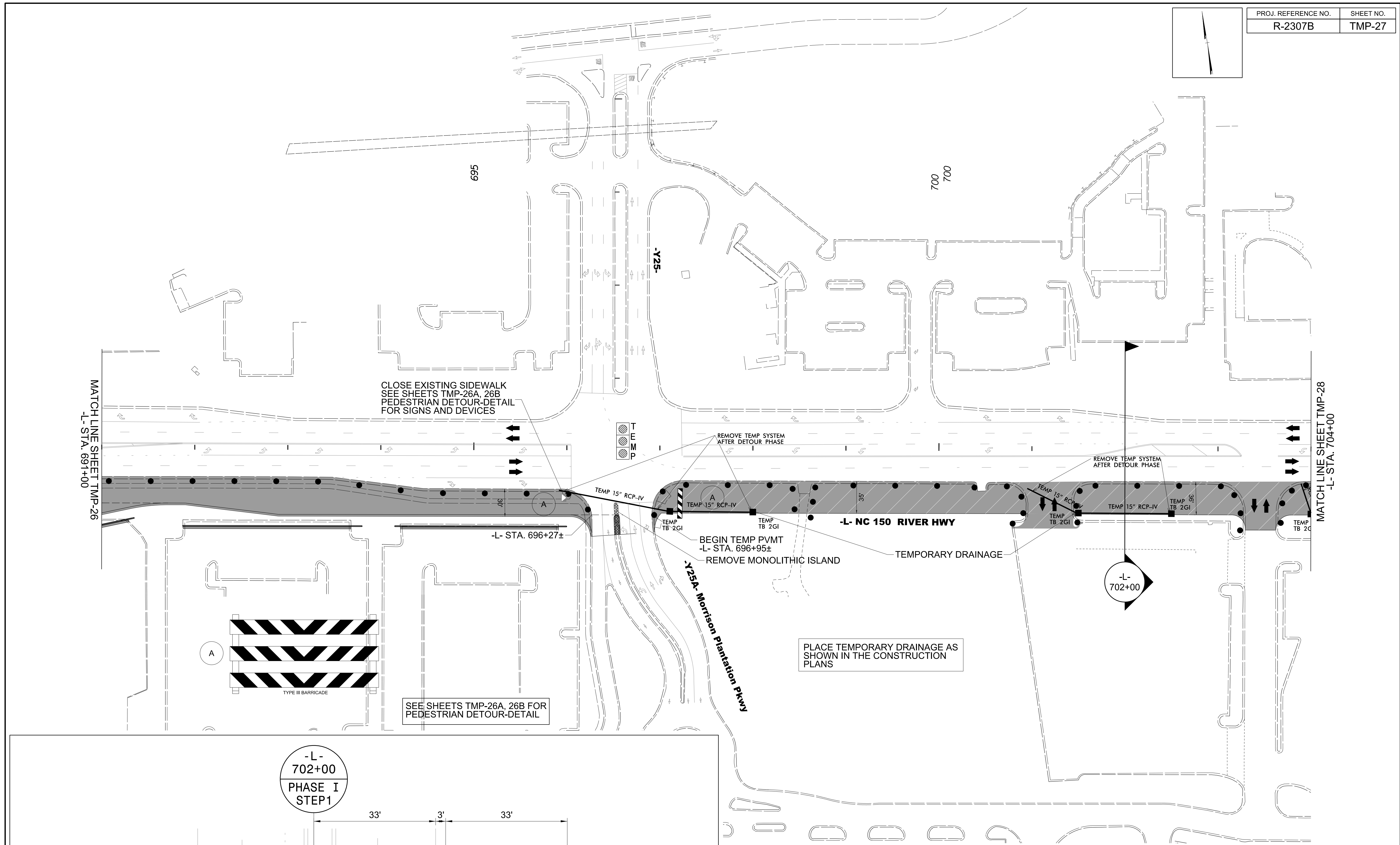

**Stantec**  
 Stantec Consulting Services Inc.  
 801 Jones Franklin Road  
 Suite 300  
 Raleigh, NC 27606  
 Tel. 919.851.6866  
 Fax. 919.851.7024  
 www.stantec.com  
 License No. F-0672

DocuSigned by:  
 J.W. Woolard  
 SEAL  
 PROFESSIONAL ENGINEER  
 19862  
 J. W. WOOLARD, P.E.  
 7/24/2024

**DOCUMENT NOT CONSIDERED FINAL  
 UNLESS ALL SIGNATURES COMPLETED**

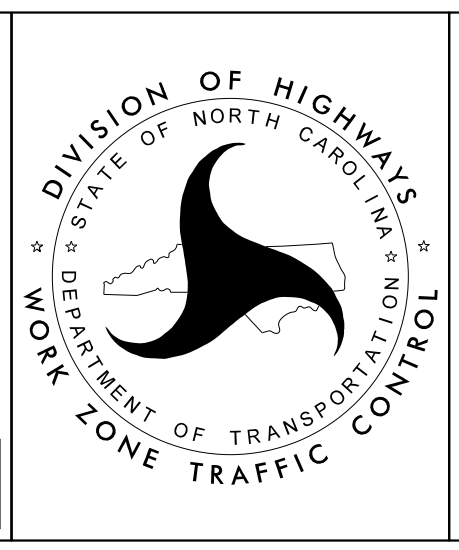

**-L- NC 150  
 PHASE I  
 STEP 1**

6/27/2024  
 U:\Traffic\Transportation Management Plan\TCP\PLAN SHEETS\NR-2307B-TMP-27\_PHASE\_01\_STEP\_01.dgn  
 dorichardson

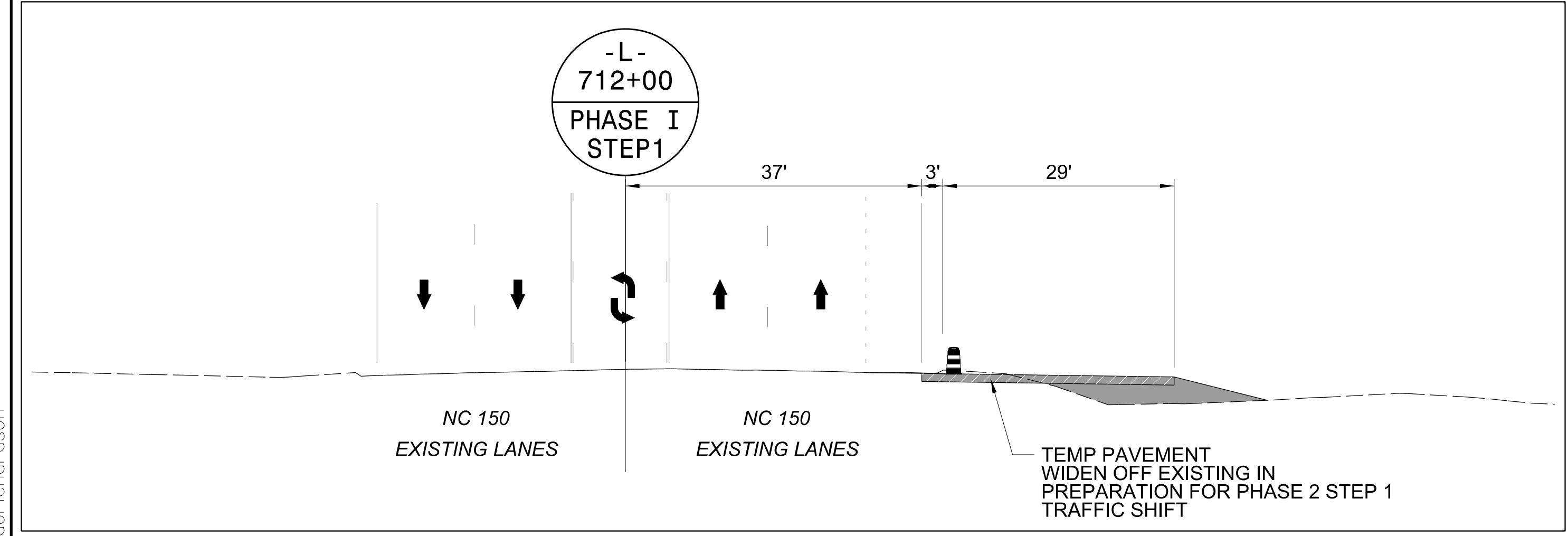
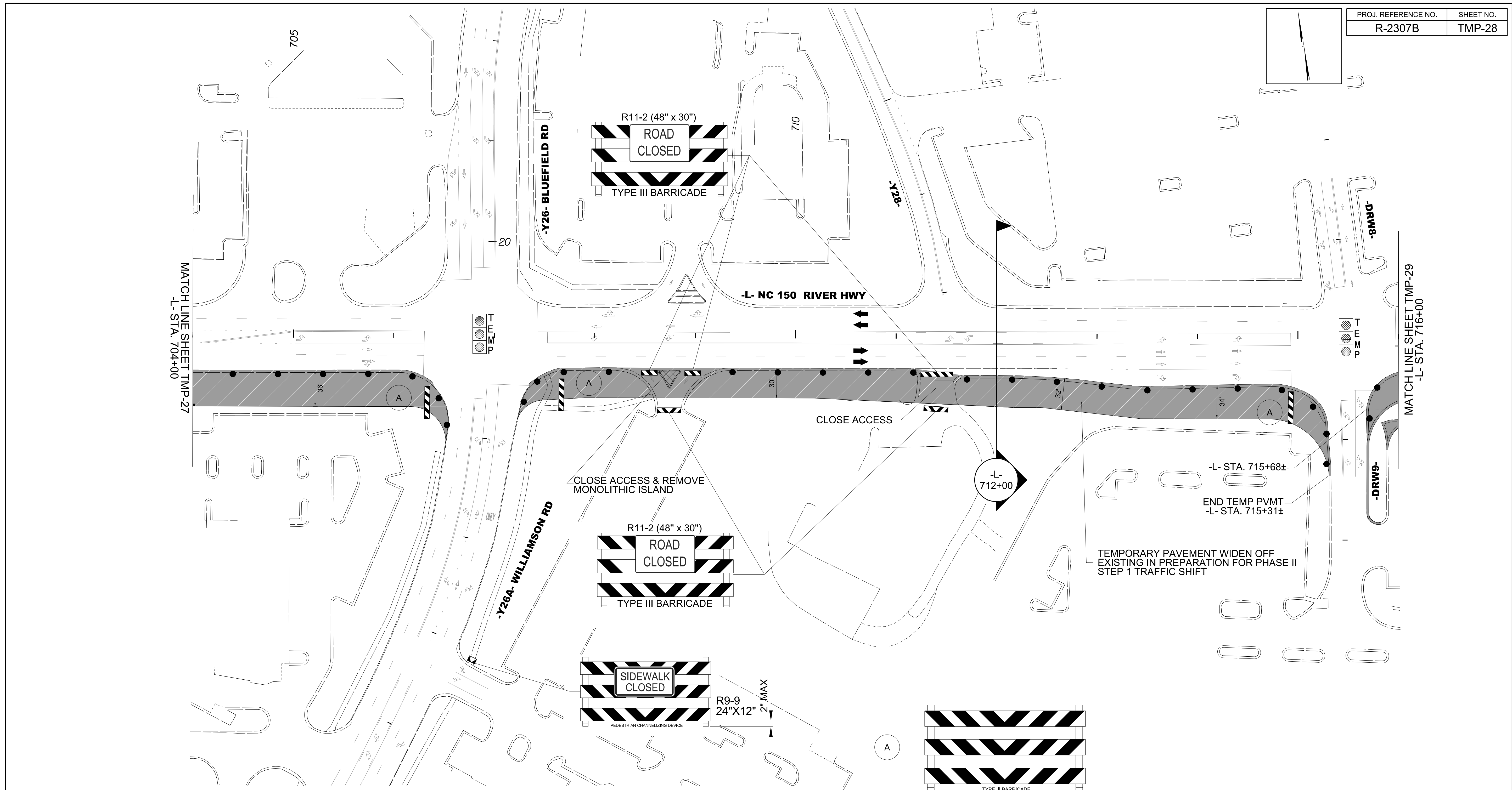

**Stantec**  
 Stantec Consulting Services Inc.  
 801 Jones Franklin Road  
 Suite 300  
 Raleigh, NC 27606  
 Tel. 919.851.6866  
 Fax. 919.851.7024  
 www.stantec.com  
 License No. F-0672

7/24/2024

Seal of J.W. Williams, Professional Engineer, No. 919862, State of North Carolina.

**DOCUMENT NOT CONSIDERED FINAL  
 UNLESS ALL SIGNATURES COMPLETED**

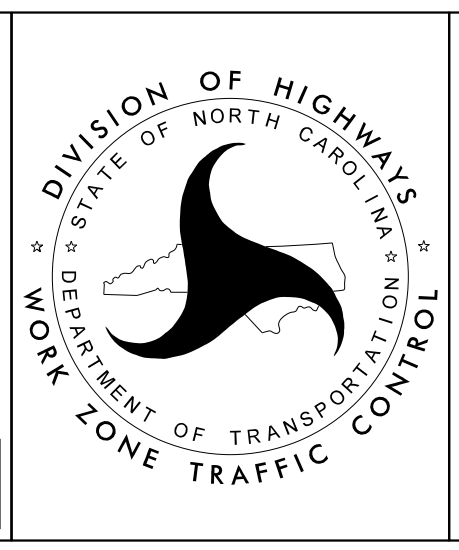

**-L- NC 150  
 PHASE I  
 STEP 1**

6/4/2024  
 Us:\Traffic\Transportation Management Plan\TCP\PLAN SHEETS\VR-2307B-TMP-28\_PHASE\_01-STEP\_01.dgn  
 dorichardson

PROJ. REFERENCE NO.	SHEET NO.
R-2307B	TMP-29

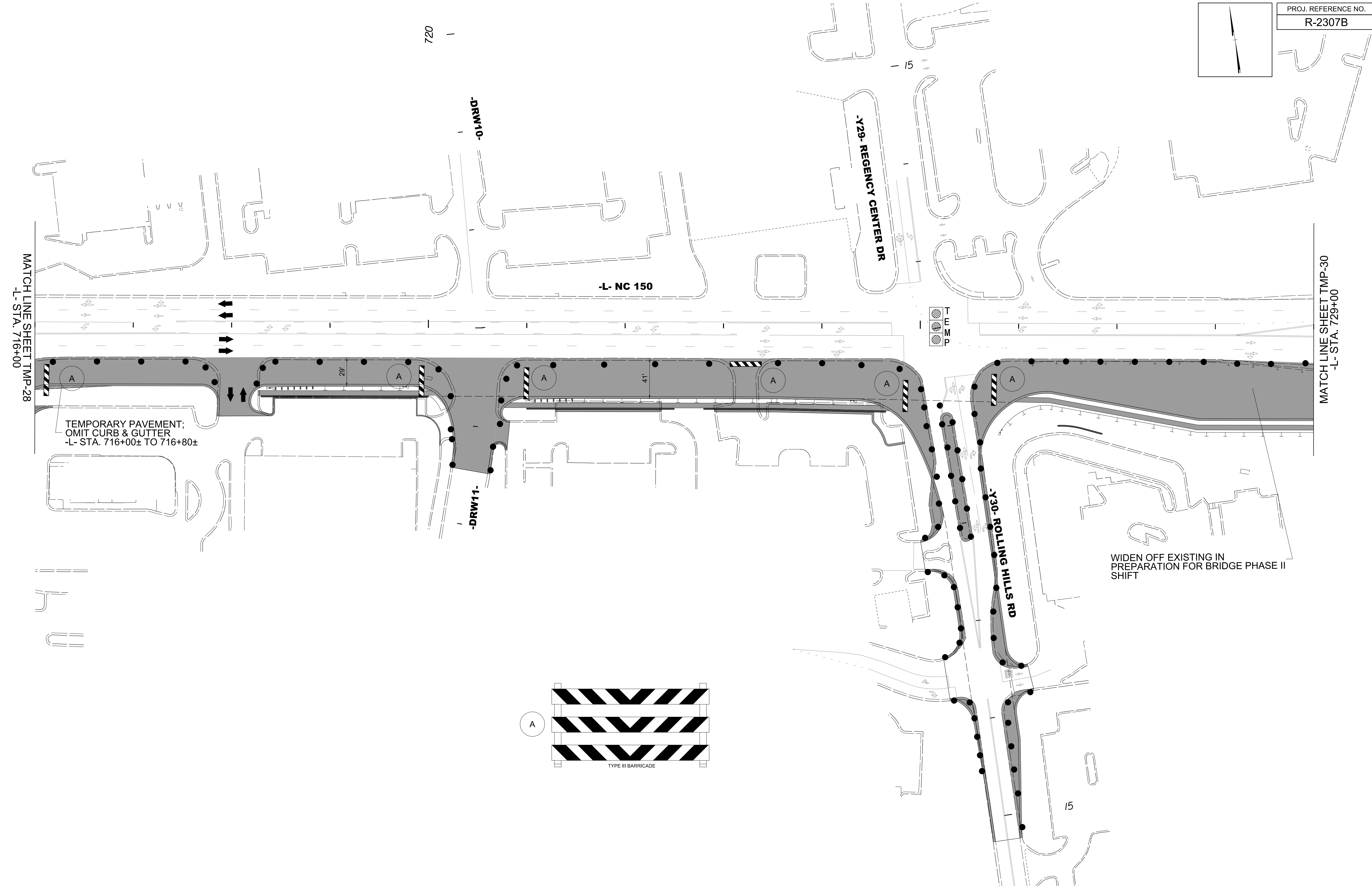

TEMPORARY PAVEMENT;  
OMIT CURB & GUTTER  
-L- STA. 716+00± TO 716+80±

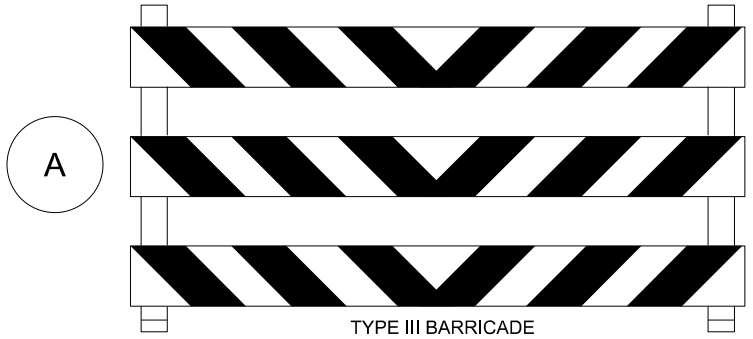

6/4/2024  
U:\Traffic\Transportation Management\Plan\TCP\PLAN SHEETS\IR-2307B-TMP\_29\_PHASE\_01.dgn  
dorichardson

**Stantec**  
Stantec Consulting Services Inc.  
801 Jones Franklin Road  
Suite 300  
Raleigh, NC 27606  
Tel. 919.851.6866  
Fax. 919.851.7024  
www.stantec.com  
License No. F-0672

7/24/2024  
DOCUMENT NOT CONSIDERED FINAL  
UNLESS ALL SIGNATURES COMPLETED

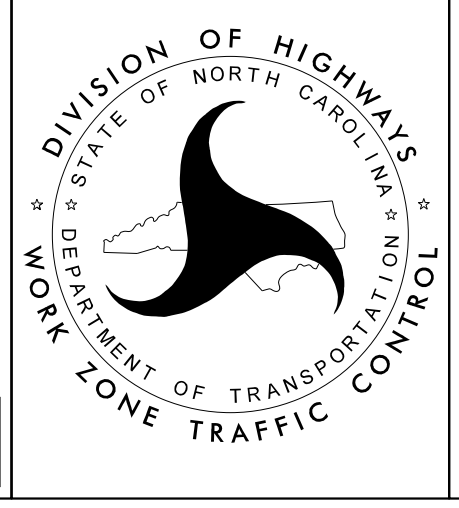

-L- NC 150  
PHASE I  
STEP 1

SEE TMP-30B FOR CROSS SECTION DETAILS

SEE TMP-30A FOR SHORING DETAILS

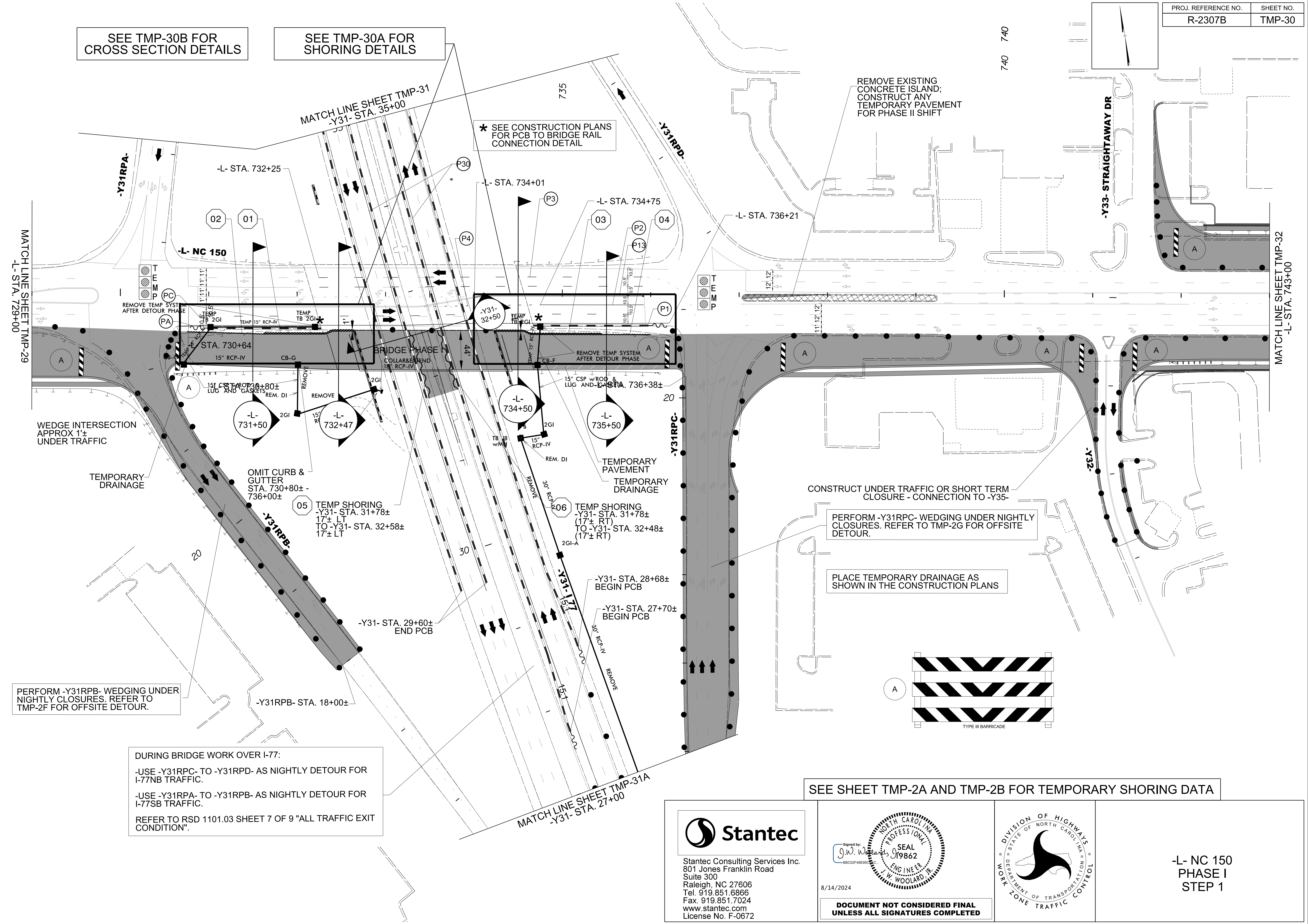

\* SEE CONSTRUCTION PLANS FOR PCB TO BRIDGE RAIL CONNECTION DETAIL

REMOVE EXISTING CONCRETE ISLAND; CONSTRUCT ANY TEMPORARY PAVEMENT FOR PHASE II SHIFT

PERFORM -Y31RPB- WEDGING UNDER NIGHTLY CLOSURES. REFER TO TMP-2F FOR OFFSITE DETOUR.

DURING BRIDGE WORK OVER I-77:

- USE -Y31RPC- TO -Y31RPD- AS NIGHTLY DETOUR FOR I-77NB TRAFFIC.
- USE -Y31RPA- TO -Y31RPB- AS NIGHTLY DETOUR FOR I-77SB TRAFFIC.

REFER TO RSD 1101.03 SHEET 7 OF 9 "ALL TRAFFIC EXIT CONDITION".

SEE SHEET TMP-2A AND TMP-2B FOR TEMPORARY SHORING DATA

8/14/2024  
L:\Traffic\Transportation Management\Plan\TCP\PLAN SHEETS\NR-2307B-TMP\_30\_PHASE\_01\_STEP 01.dgn  
angood

**Stantec**  
 Stantec Consulting Services Inc.  
 801 Jones Franklin Road  
 Suite 300  
 Raleigh, NC 27606  
 Tel. 919.851.6866  
 Fax. 919.851.7024  
 www.stantec.com  
 License No. F-0672

Signed by: *J.W. Woolard*  
 PROFESSIONAL SEAL  
 19862  
 ENGINEER  
 W. WOOLARD, R.  
 8/14/2024  
 DOCUMENT NOT CONSIDERED FINAL  
 UNLESS ALL SIGNATURES COMPLETED

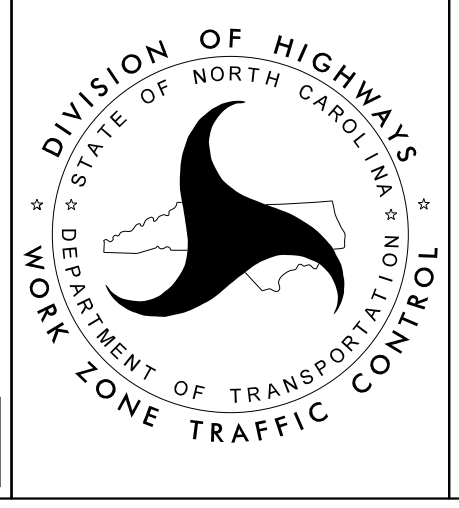

-L- NC 150  
PHASE I  
STEP 1



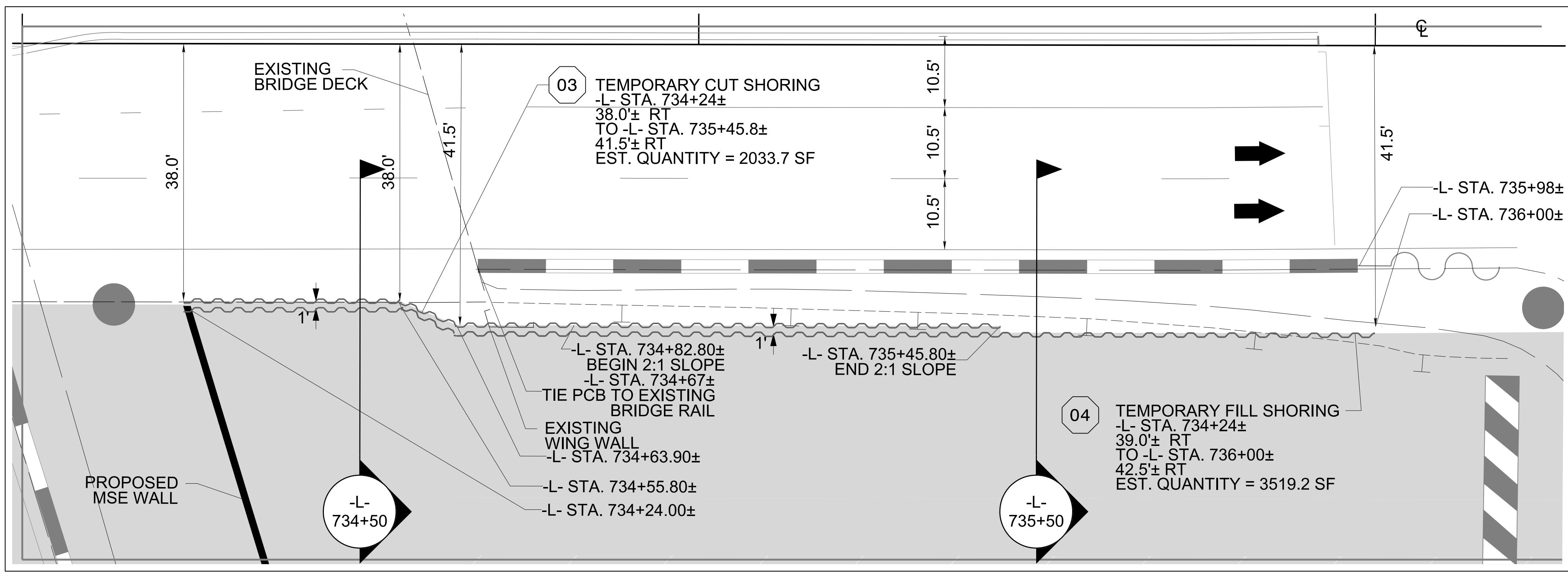
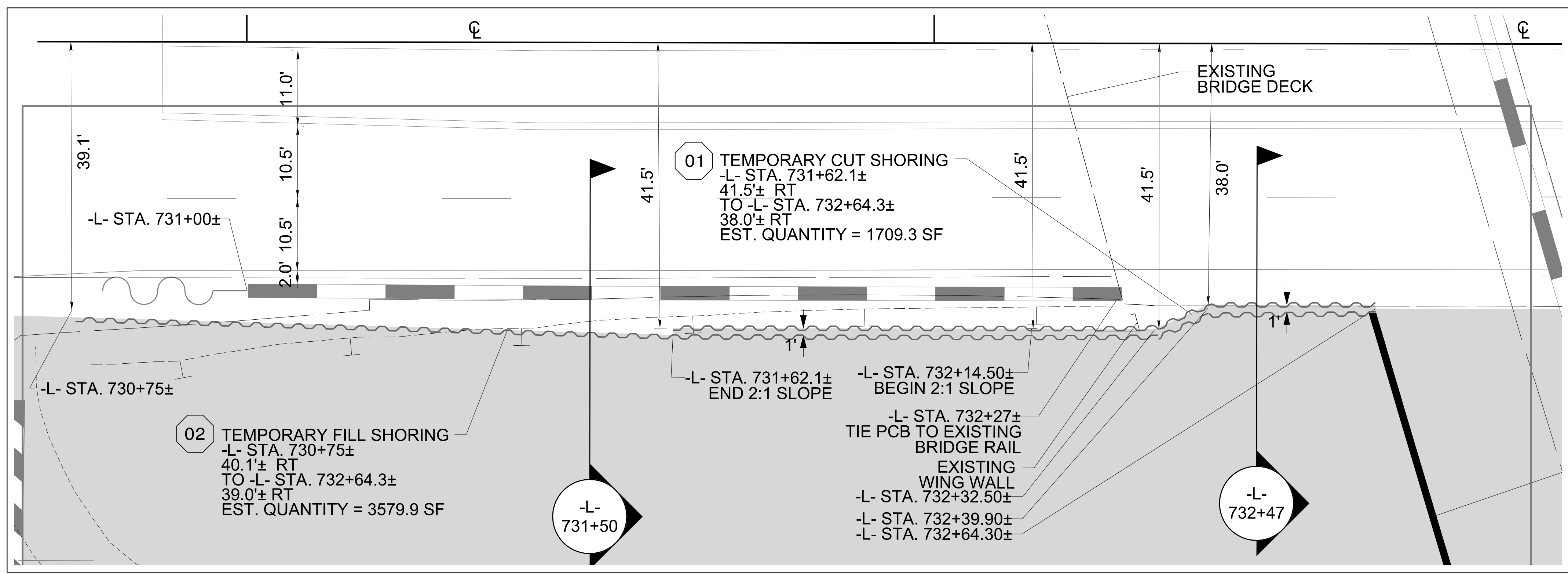

SEE SHEET TMP-2A & TMP-2B FOR TEMPORARY SHORING DATA

**Stantec**  
 Stantec Consulting Services Inc.  
 801 Jones Franklin Road  
 Suite 300  
 Raleigh, NC 27606  
 Tel. 919.851.6866  
 Fax. 919.851.7024  
 www.stantec.com  
 License No. F-0672

DocuSigned by  
 J.W. Williams  
 58C02F4E95D

7/24/2024

SEAL  
 19862  
 W. WOOLARD, R.

DOCUMENT NOT CONSIDERED FINAL  
 UNLESS ALL SIGNATURES COMPLETED

DIVISION OF HIGHWAYS  
 STATE OF NORTH CAROLINA  
 DEPARTMENT OF TRANSPORTATION  
 WORK ZONE TRAFFIC CONTROL

-L- NC 150  
PHASE I  
STEP 1  
SHORING DETAILS

6/4/2024  
 U:\Traffic\Transportation Management\Plan\TCP\PLAN SHEETS\VR-2307B-TMP\_30A\_PHASE\_01\_STEP\_01.dgn  
 dorichardson

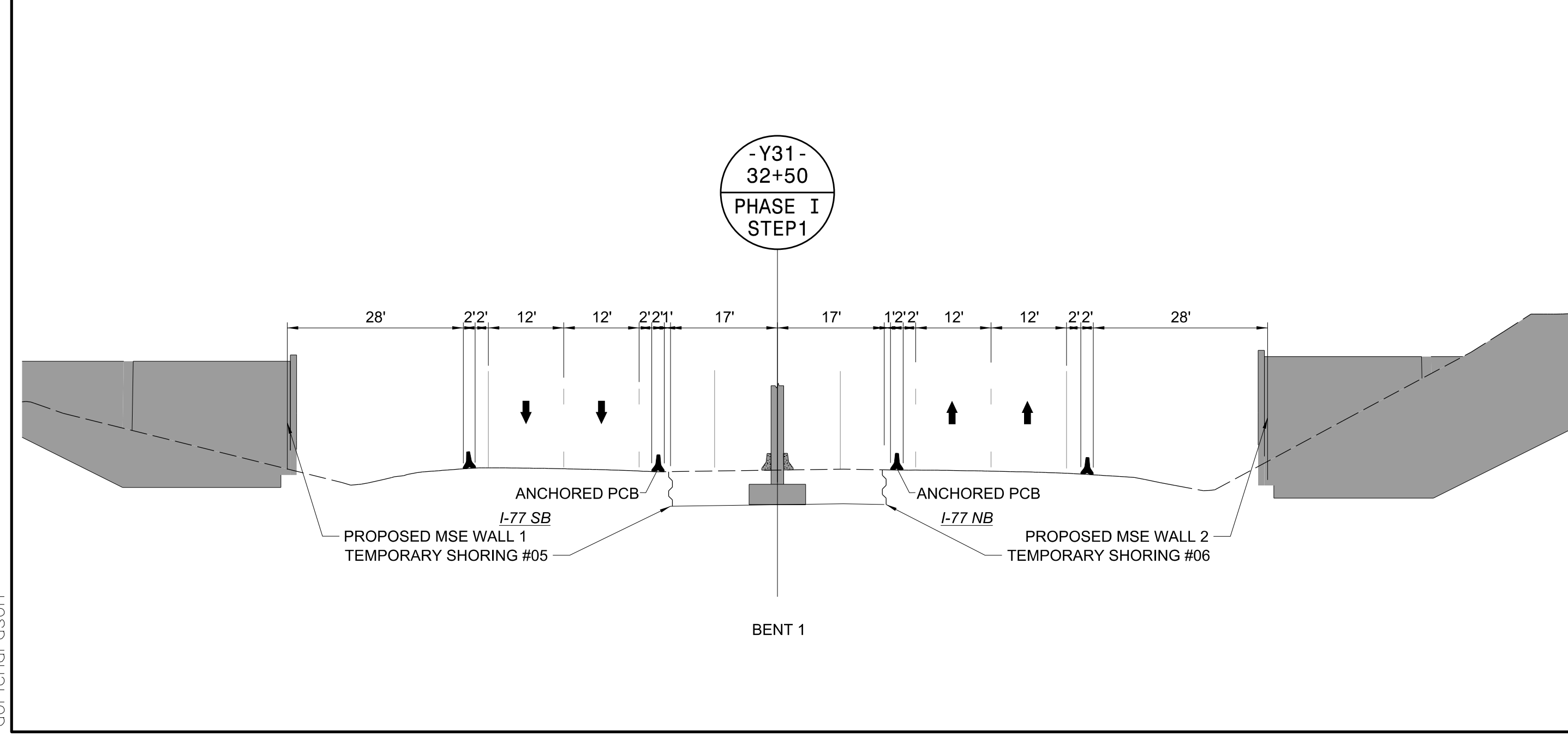
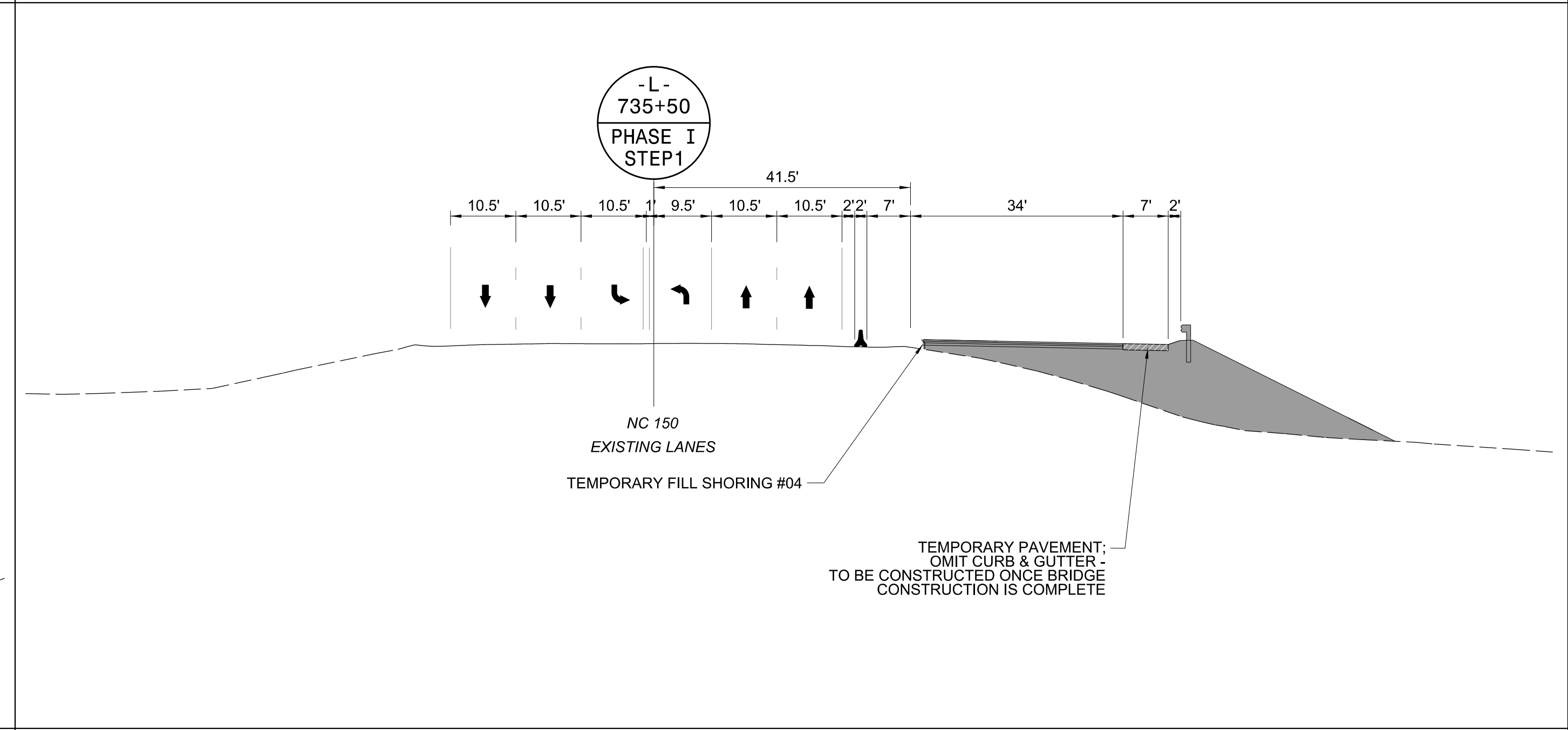
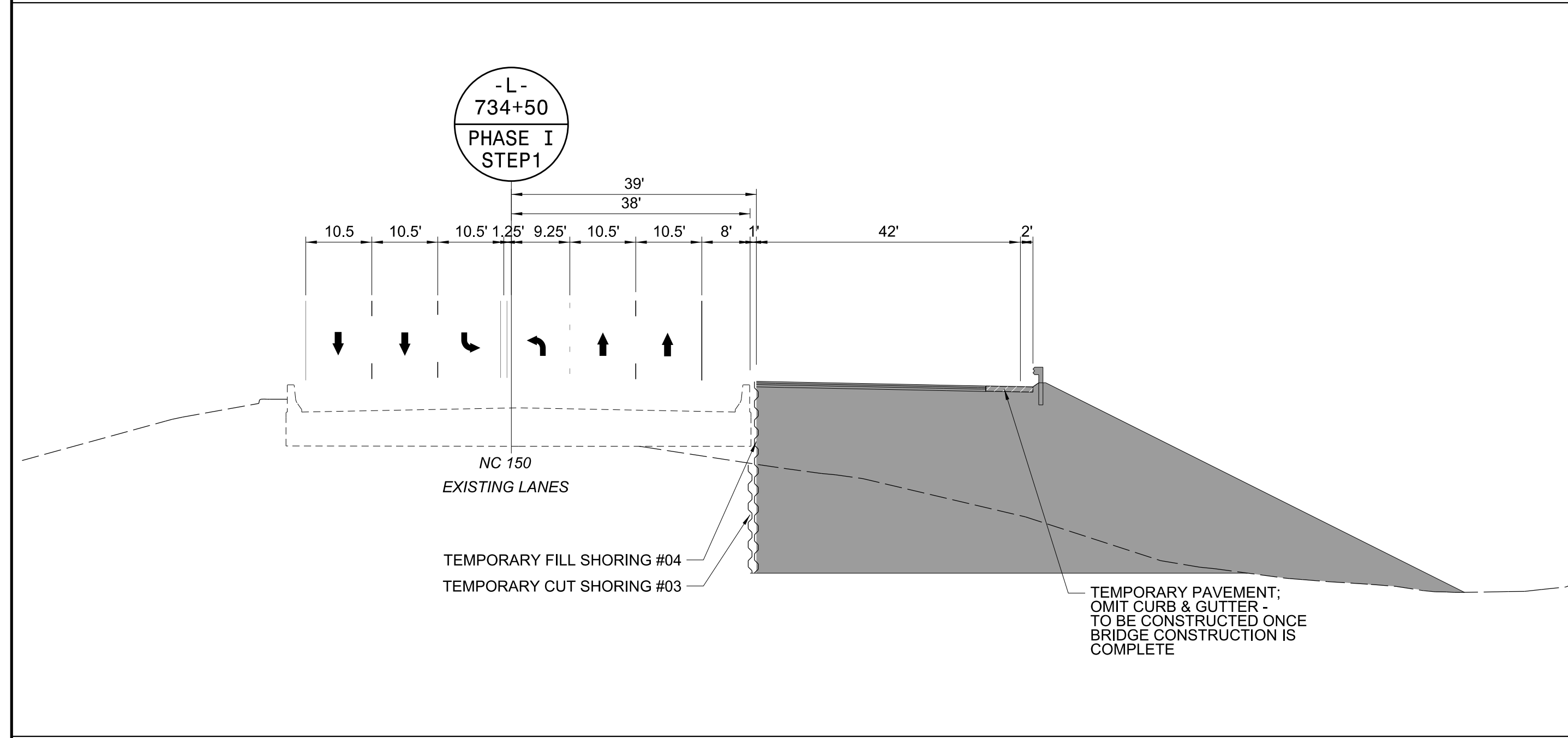
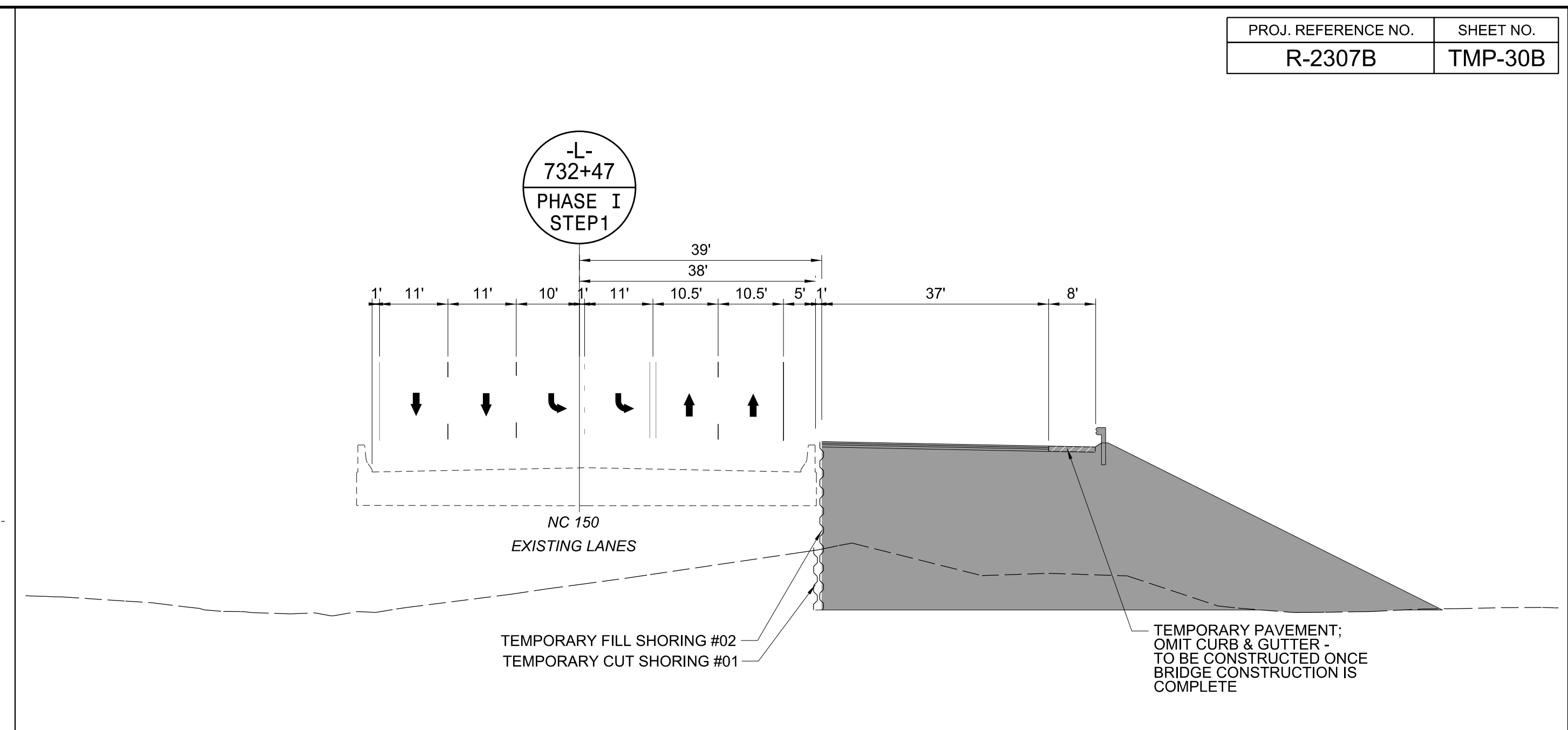
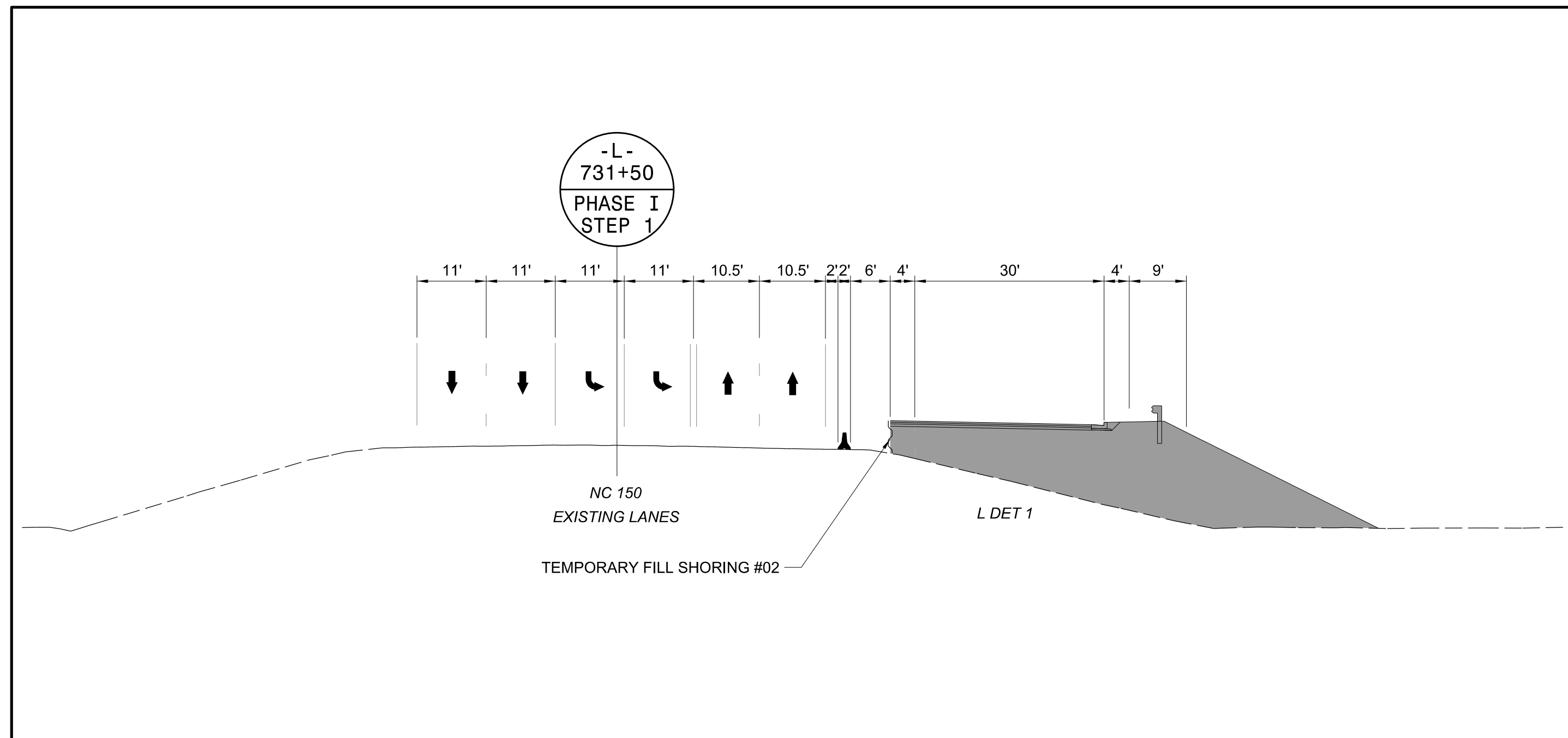

<p>Stantec Consulting Services Inc. 801 Jones Franklin Road Suite 300 Raleigh, NC 27606 Tel. 919.851.6866 Fax. 919.851.7024 www.stantec.com License No. F-0672</p>	<p>7/24/2024</p> <p><b>DOCUMENT NOT CONSIDERED FINAL UNLESS ALL SIGNATURES COMPLETED</b></p>	<p>DIVISION OF HIGHWAYS DEPARTMENT OF TRANSPORTATION WORK ZONE TRAFFIC CONTROL</p>	<p>-L- NC 150 PHASE I STEP 1 CROSS SECTION DETAILS</p>
--	--	--	--

6/4/2024  
 U:\Traffic\Transportation Management Plan\TCP\PLAN SHEETS\IR-2307B-TMP\_30B-PHASE\_01\_STEP\_01.dgn  
 dorichardson

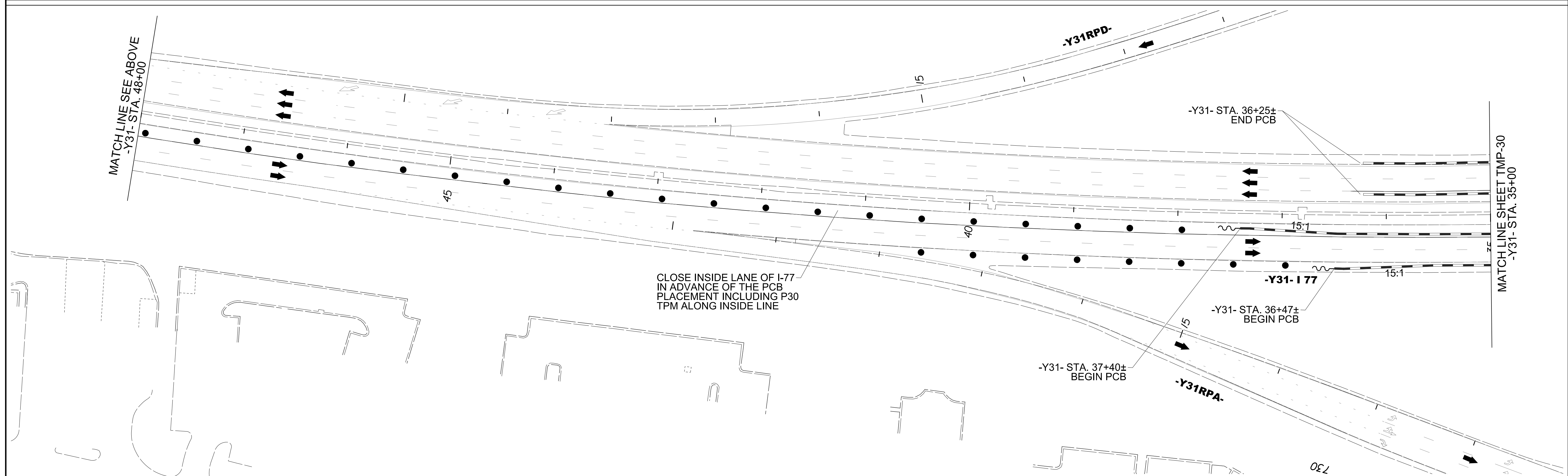
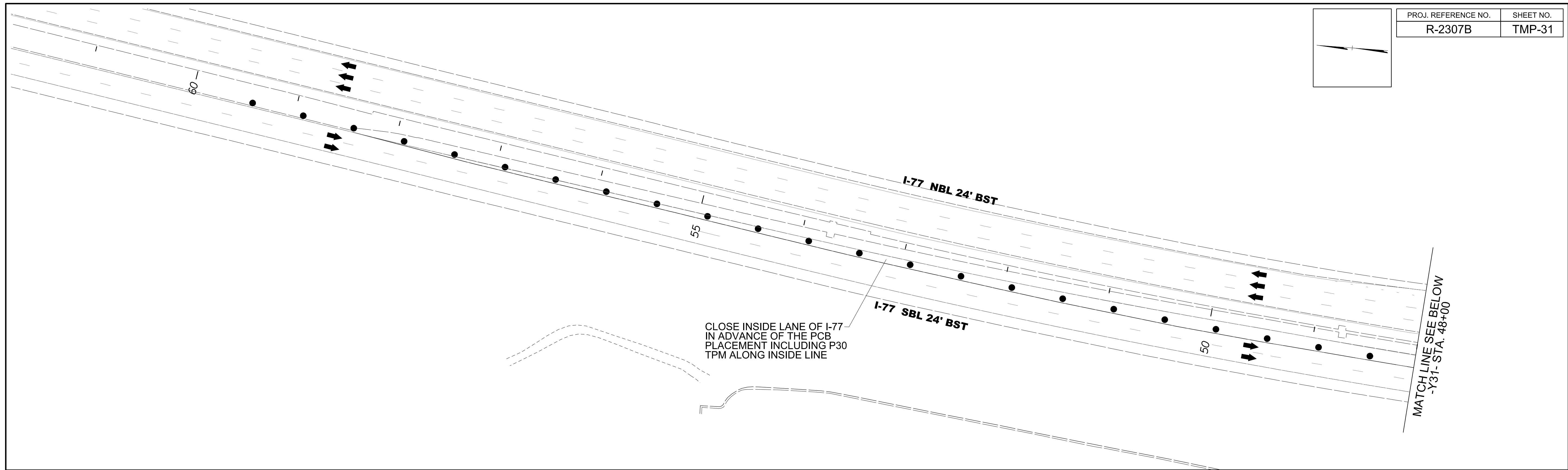
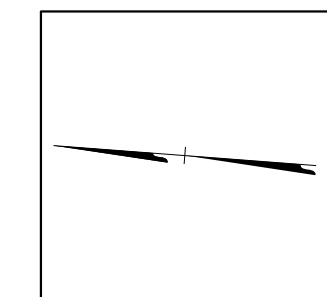

8/14/2024  
 U:\Traffic\Transportation Management Plan\TCP\PLAN SHEETS\R-2307B-TMP\_31-PHASE\_01-STEP\_01.dgn  
 angood

Stantec Consulting Services Inc.  
801 Jones Franklin Road  
Suite 300  
Raleigh, NC 27606  
Tel. 919.851.6866  
Fax. 919.851.7024  
www.stantec.com  
License No. F-0672

Signed by:  
*J.W. Williams*  
SEAL  
19862  
ENGINEER  
W. WOOLARD, R.

8/14/2024

**DOCUMENT NOT CONSIDERED FINAL  
UNLESS ALL SIGNATURES COMPLETED**

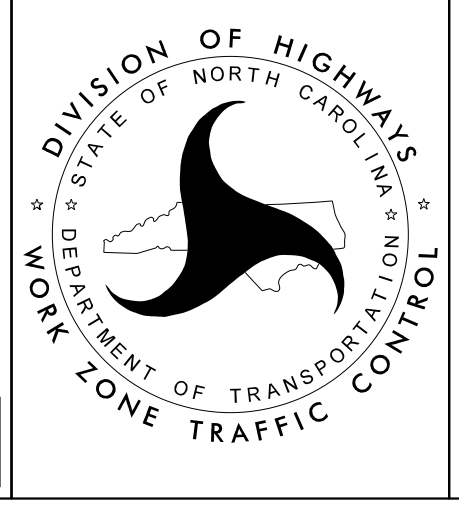

**-L- NC 150  
PHASE I  
STEP 1**

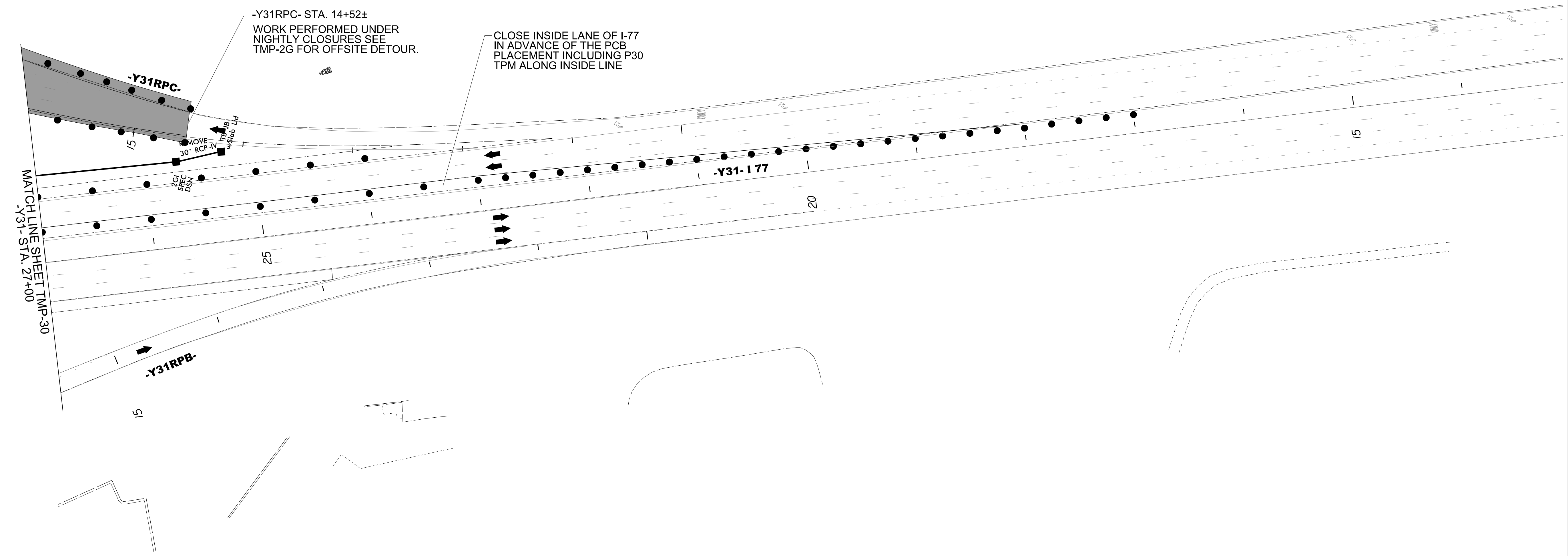
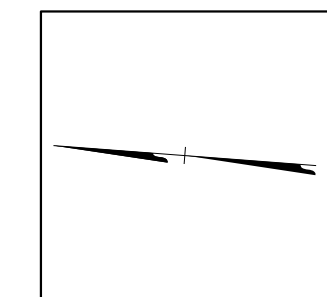

8/14/2024  
 U:\Traffic\Transportation Management Plan\TCP\PLAN SHEETS\IR-2307B-TMP\_31A-PHASE-01-STEP\_01.dgn  
 angood

Stantec Consulting Services Inc.  
 801 Jones Franklin Road  
 Suite 300  
 Raleigh, NC 27606  
 Tel. 919.851.6866  
 Fax. 919.851.7024  
 www.stantec.com  
 License No. F-0672

Signed by: *J.W. Woolard*

8/14/2024

**DOCUMENT NOT CONSIDERED FINAL  
UNLESS ALL SIGNATURES COMPLETED**

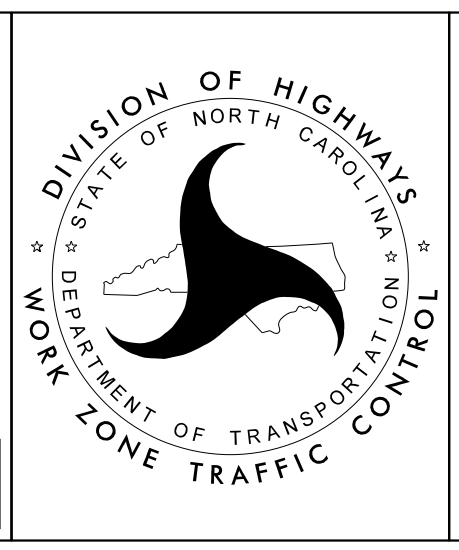

-L- NC 150  
PHASE I  
STEP 1

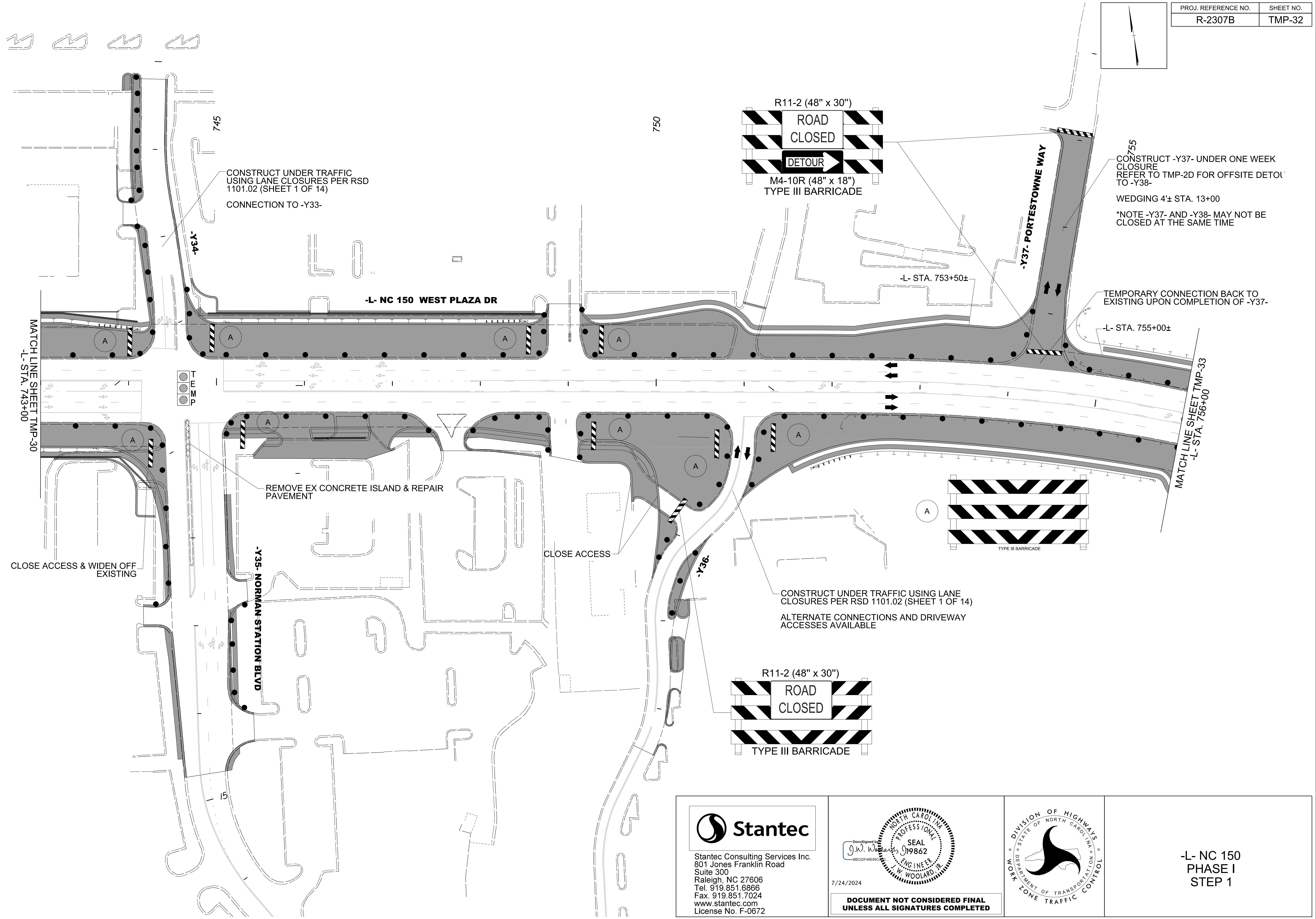

6/4/2024  
 U:\Traffic\Transportation Management Plan\TCP\PLAN SHEETS\IR-2307B\_TMP\_32\_PHASE\_01\_STEP\_01.dgn  
 dorichardson

**Stantec**  
 Stantec Consulting Services Inc.  
 801 Jones Franklin Road  
 Suite 300  
 Raleigh, NC 27606  
 Tel. 919.851.6866  
 Fax. 919.851.7024  
 www.stantec.com  
 License No. F-0672

DocuSigned by  
*J.W. Woolard*  
 58C02F46E95D  
 7/24/2024

SEAL  
 PROFESSIONAL ENGINEER  
 19862  
 J. W. WOOLARD, P.E.

**DOCUMENT NOT CONSIDERED FINAL  
 UNLESS ALL SIGNATURES COMPLETED**

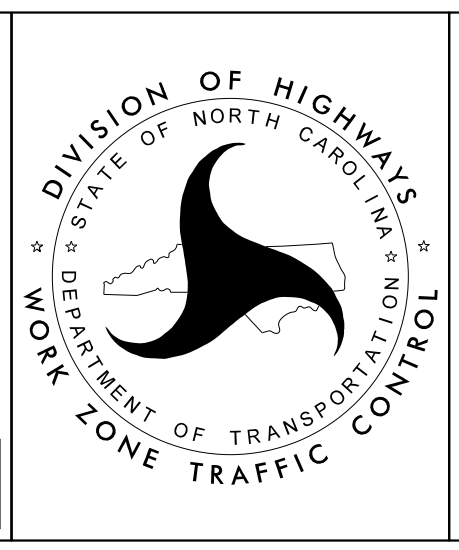

-L- NC 150  
 PHASE I  
 STEP 1

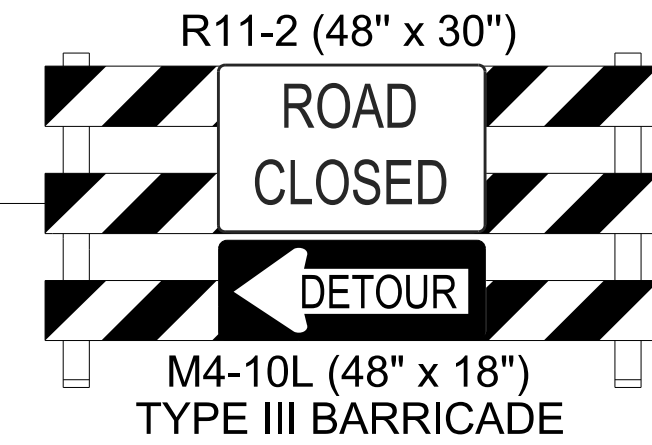
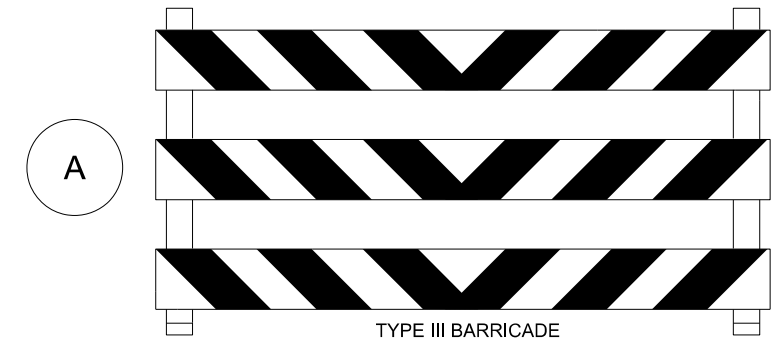
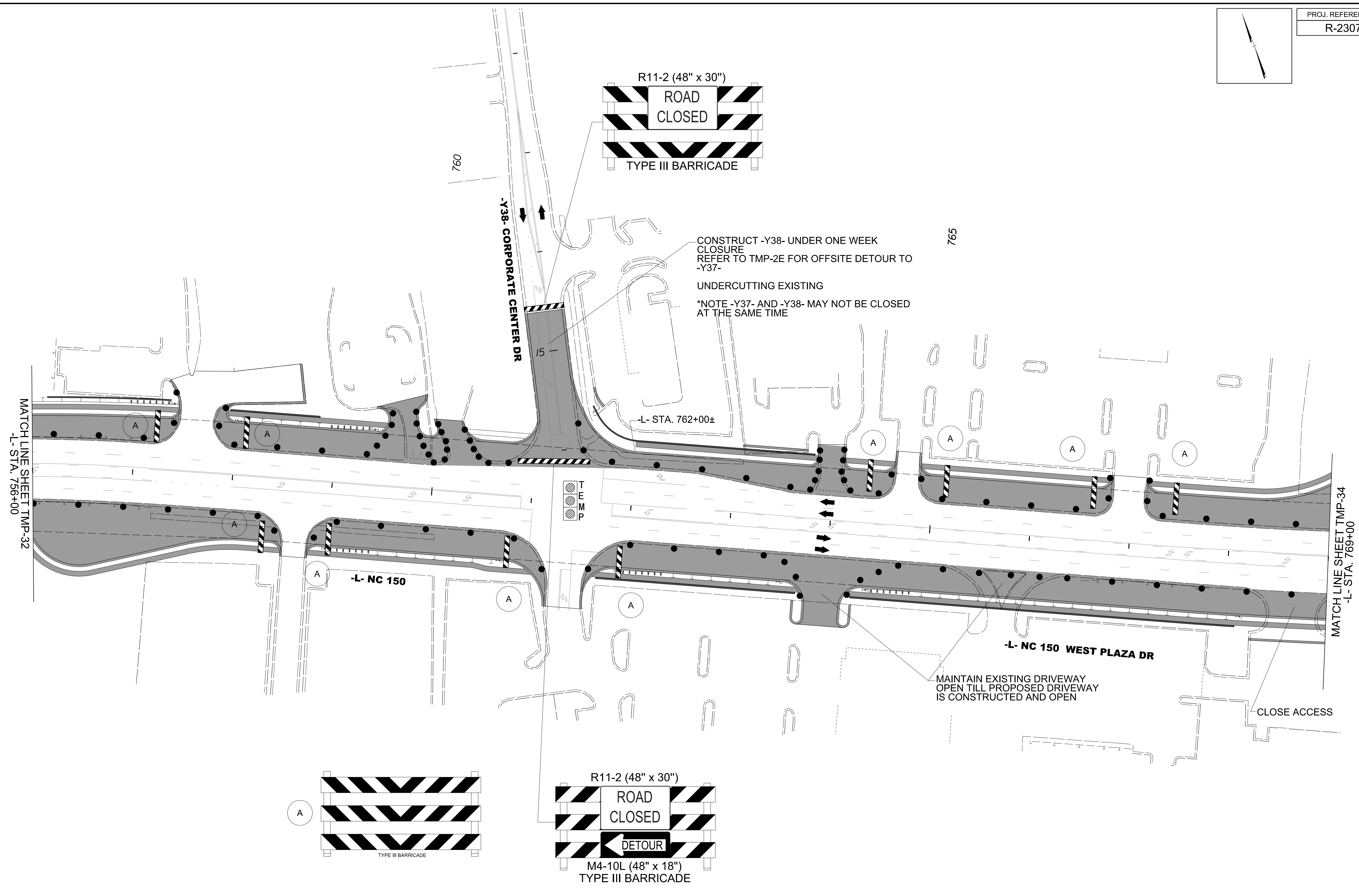
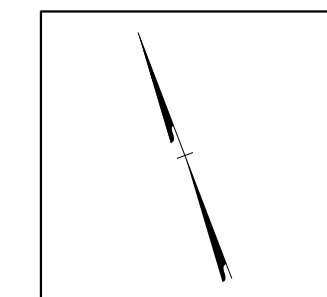

6/4/2024  
 U:\Traffic\Transportation Management\Plan\TCP\PLAN SHEETS\IR-2307B-TMP-33\_PHASE\_01\_STEP\_01.dgn  
 dorichardson

  
 Stantec Consulting Services Inc.  
 801 Jones Franklin Road  
 Suite 300  
 Raleigh, NC 27606  
 Tel. 919.851.6866  
 Fax. 919.851.7024  
 www.stantec.com  
 License No. F-0672

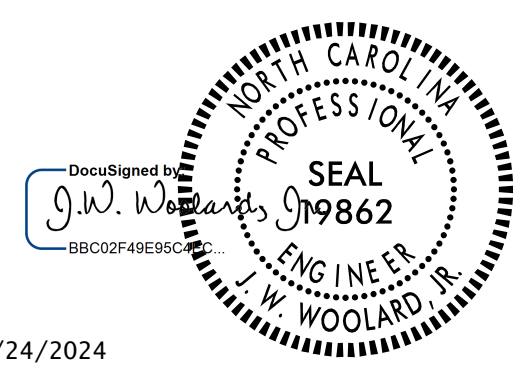
DocuSigned by:  
  
 7/24/2024  
**DOCUMENT NOT CONSIDERED FINAL  
 UNLESS ALL SIGNATURES COMPLETED**

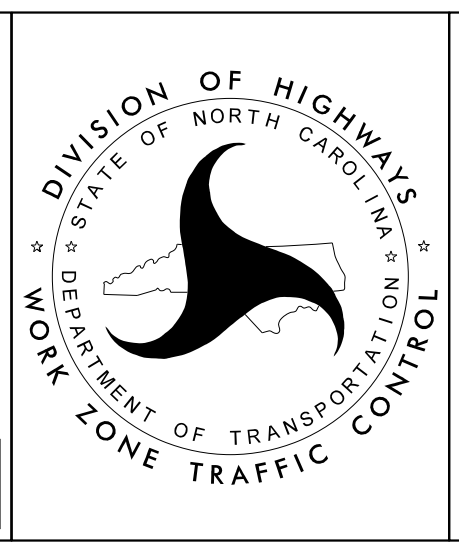

-L- NC 150  
 PHASE I  
 STEP 1

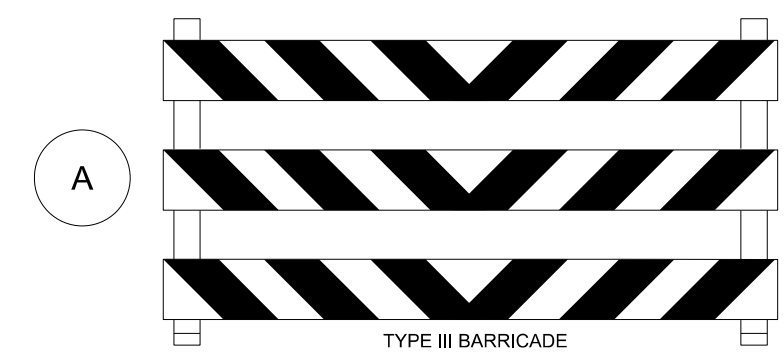
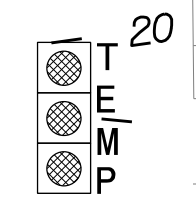
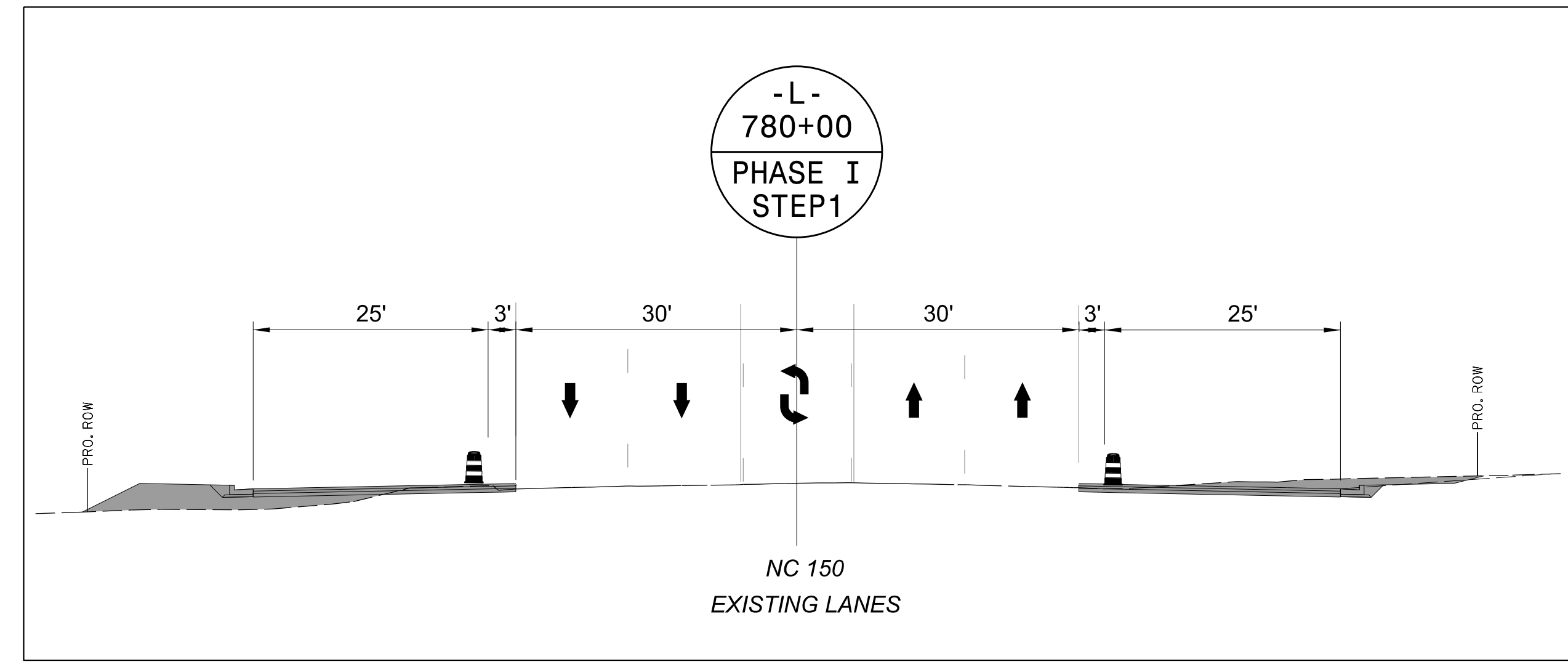
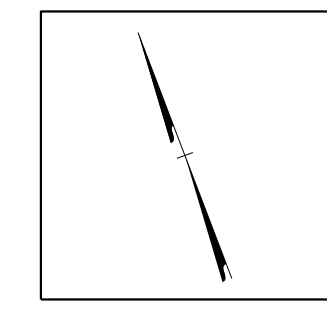

6/4/2024  
 U:\Traffic\Transportation Management Plan\TCP\PLAN SHEETS\NR-2307B-TMP\_34\_PHASE\_01-STEP\_01.dgn  
 dorichardson

**Stantec**  
 Stantec Consulting Services Inc.  
 801 Jones Franklin Road  
 Suite 300  
 Raleigh, NC 27606  
 Tel. 919.851.6866  
 Fax. 919.851.7024  
 www.stantec.com  
 License No. F-0672

DocuSigned by  
*J.W. Woolard*  
 58C02F49E950  
 7/24/2024

PROFESSOR  
 SEAL  
 19862  
 ENGINEER  
 W. WOOLARD, R.

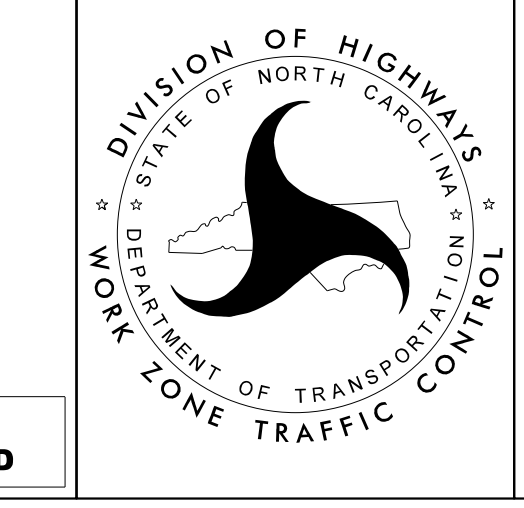

-L- NC 150  
 PHASE I  
 STEP 1

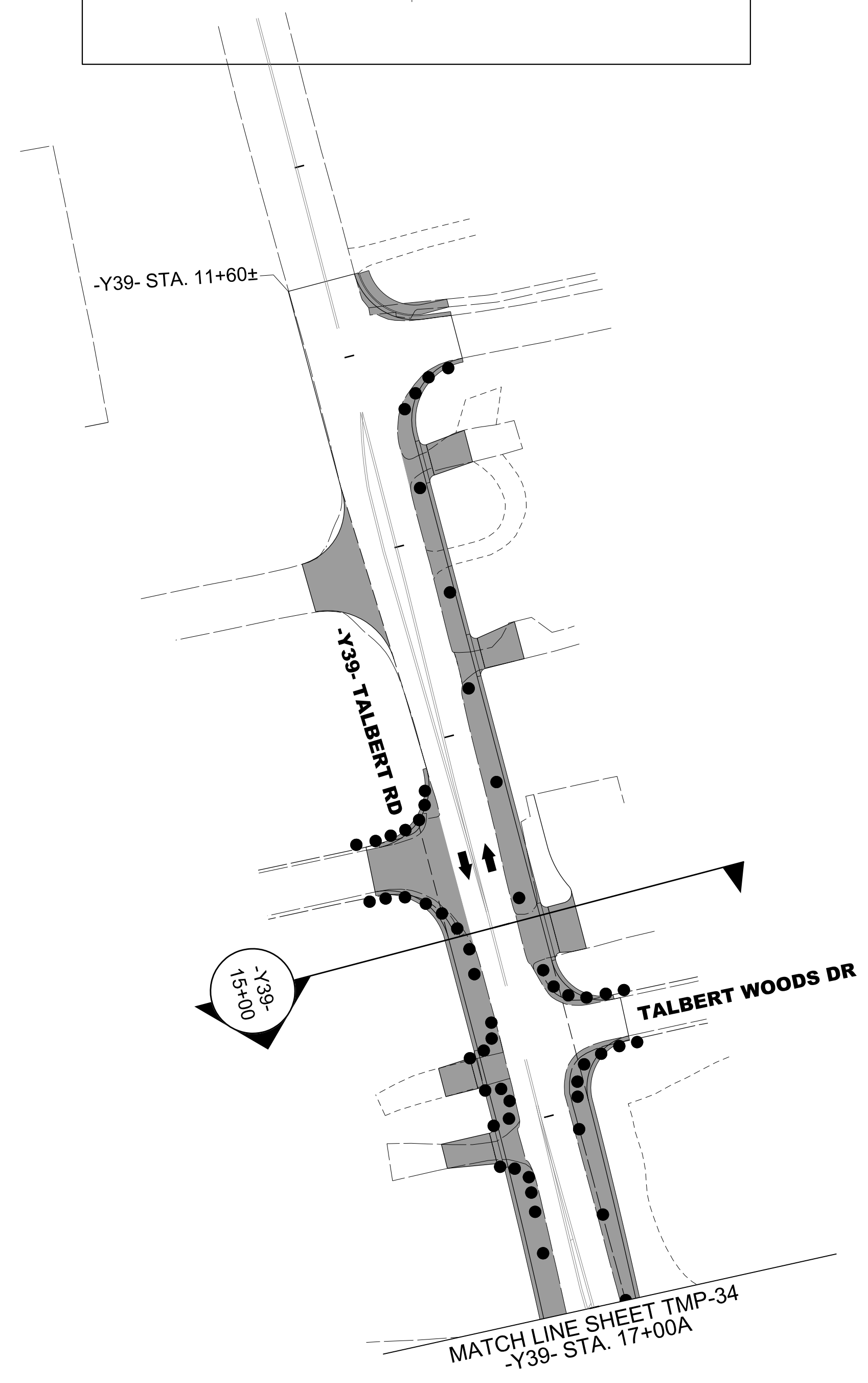
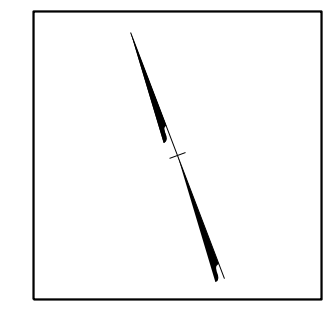
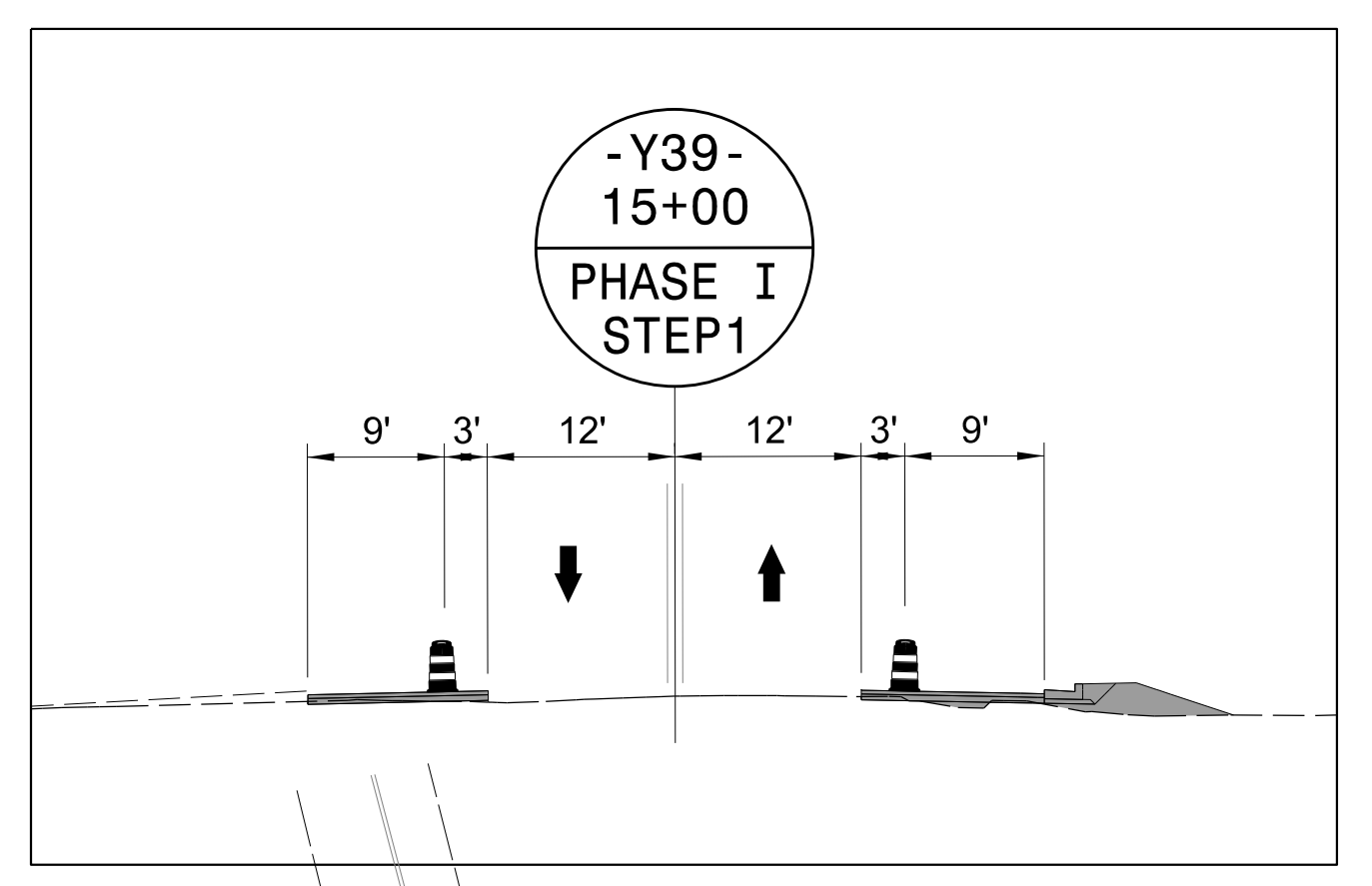

15

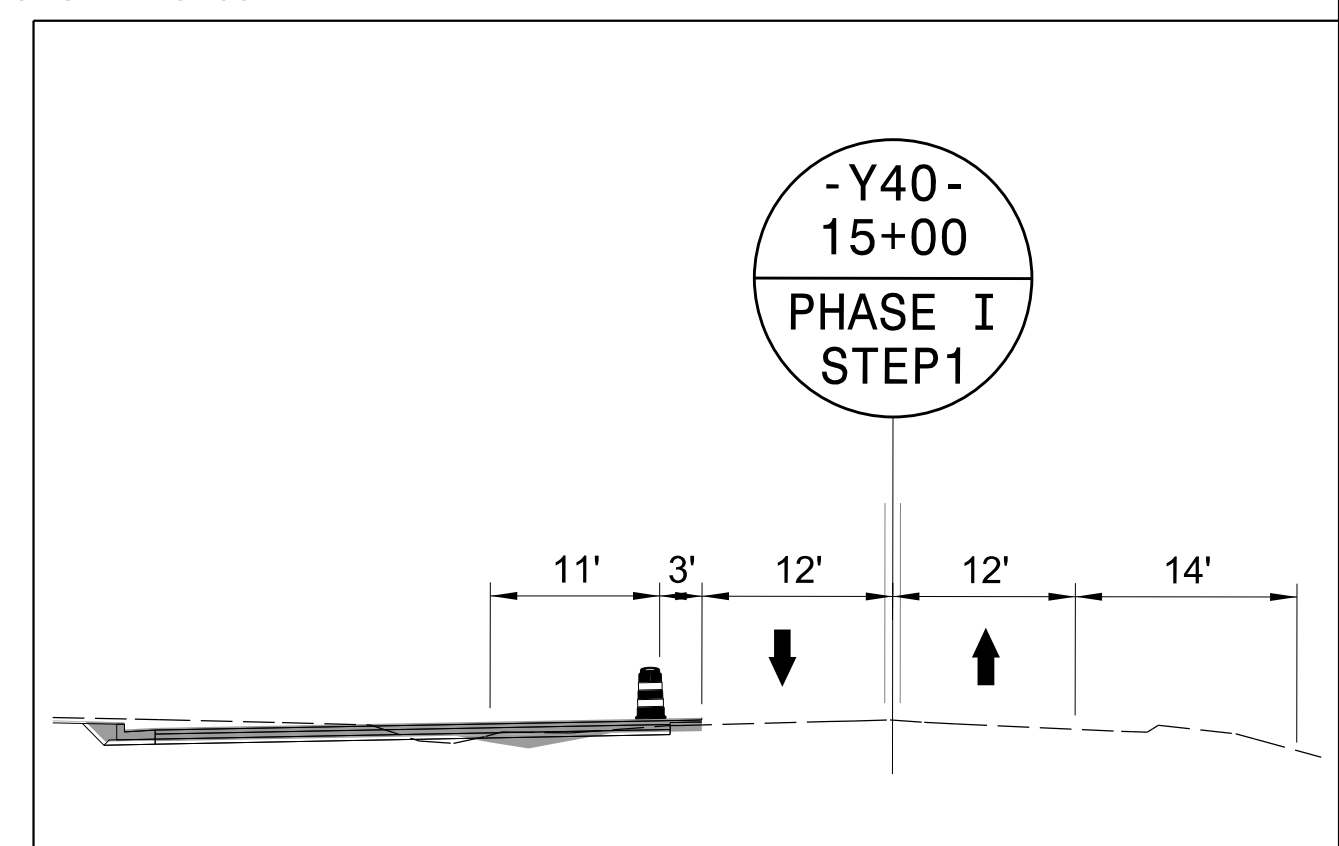
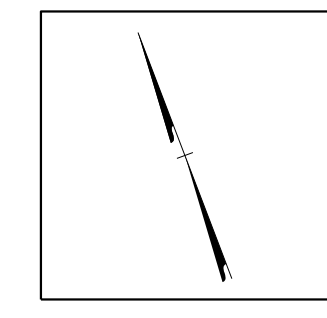
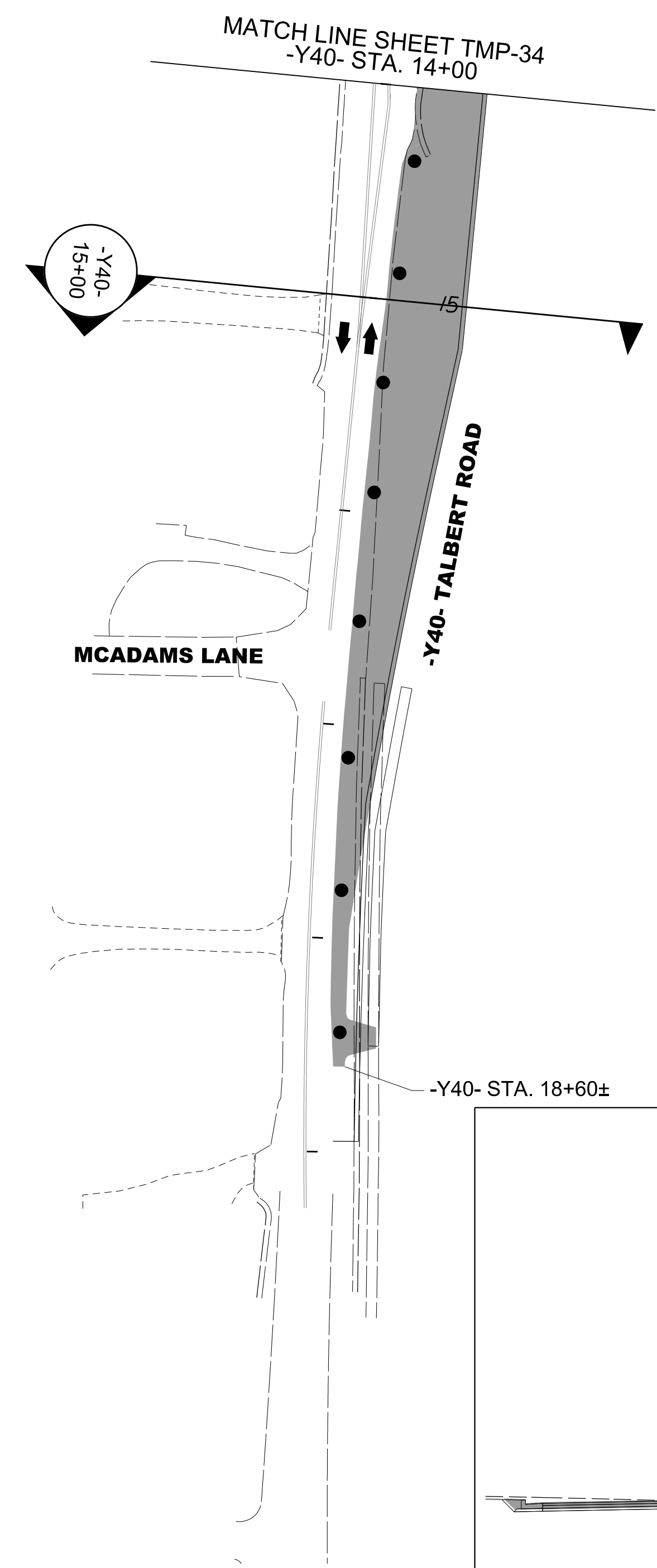

6/4/2024  
L:\Traffic\Transportation Management\Plan\TCP\PLAN SHEETS\NR-2307B-TMP-35\_PHASE\_01-STEP\_01.dgn  
dorichardson

**Stantec**  
 Stantec Consulting Services Inc.  
 801 Jones Franklin Road  
 Suite 300  
 Raleigh, NC 27606  
 Tel. 919.851.6866  
 Fax. 919.851.7024  
 www.stantec.com  
 License No. F-0672

DocuSigned by  
 J.W. Williams  
 919862  
 SEAL  
 PROFESSIONAL ENGINEER  
 W. WOOLARD, R.  
 7/24/2024  
**DOCUMENT NOT CONSIDERED FINAL  
 UNLESS ALL SIGNATURES COMPLETED**

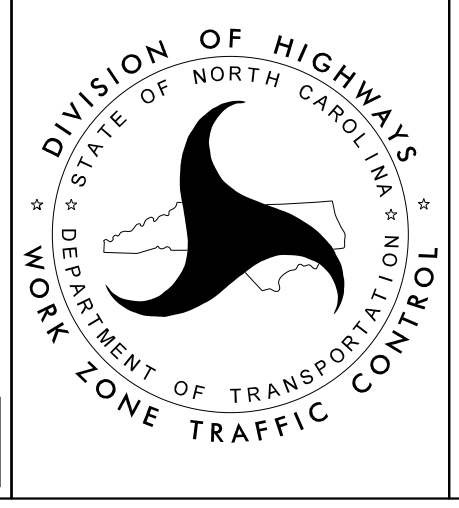

-L- NC 150  
PHASE I  
STEP 1



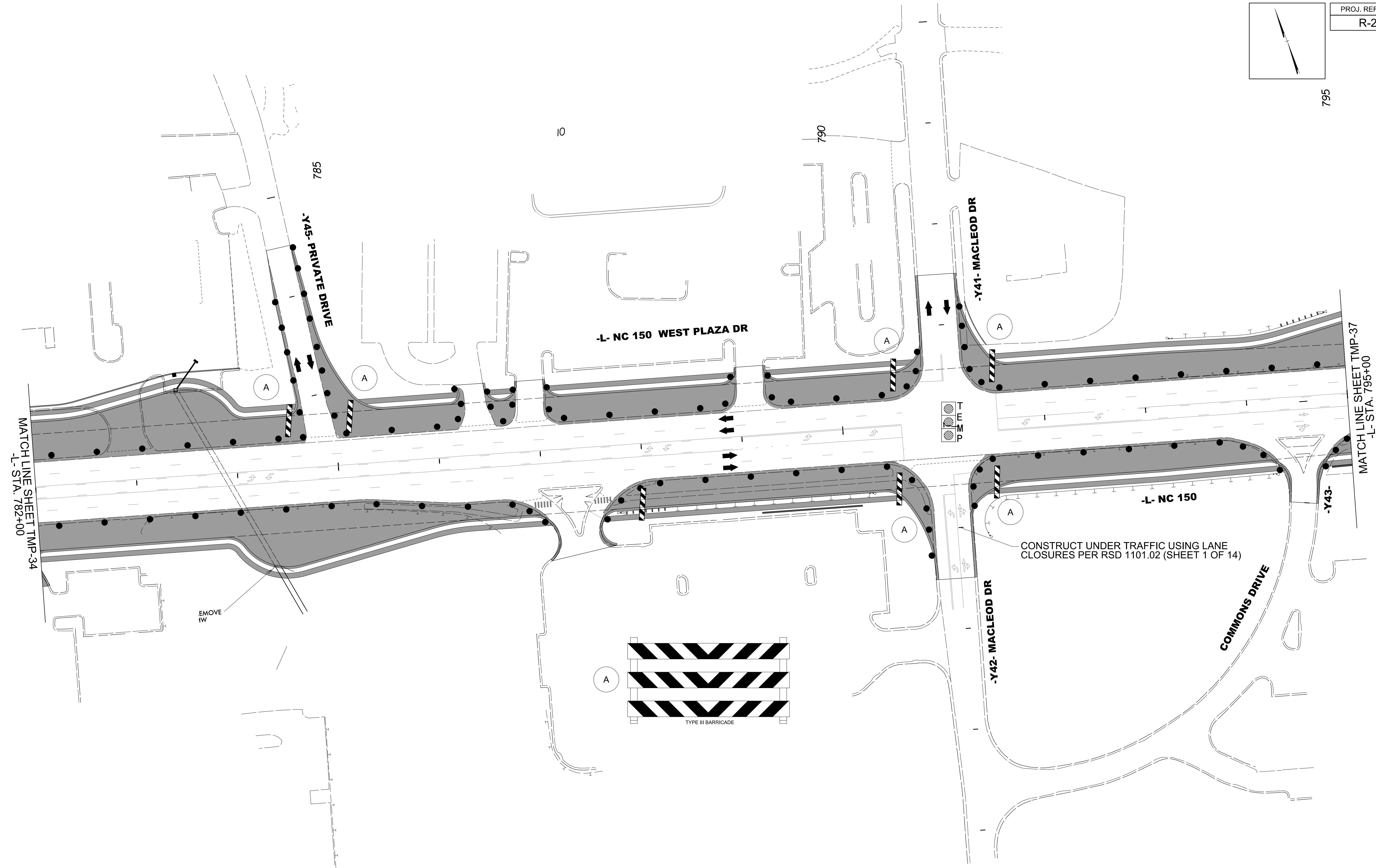
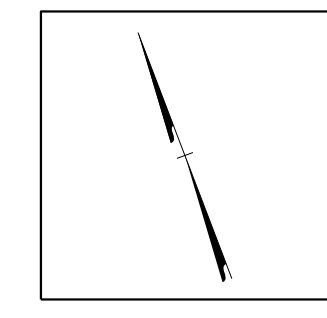

6/4/2024  
 U:\Traffic\Transportation Management\Plan\TCP\PLAN SHEETS\IR-2307B-TMP\_36\_PHASE\_01\_STEP\_0.dgn  
 dorichardson

  
 Stantec Consulting Services Inc.  
 801 Jones Franklin Road  
 Suite 300  
 Raleigh, NC 27606  
 Tel. 919.851.6866  
 Fax. 919.851.7024  
 www.stantec.com  
 License No. F-0672

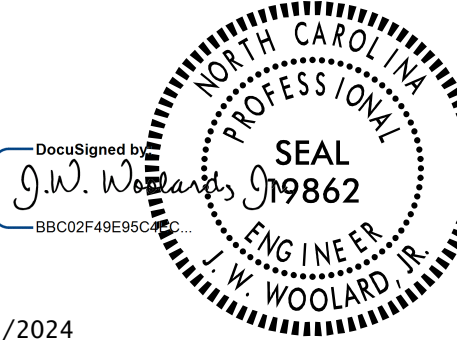
DocuSigned by:  
  
 7/24/2024  
**DOCUMENT NOT CONSIDERED FINAL  
 UNLESS ALL SIGNATURES COMPLETED**

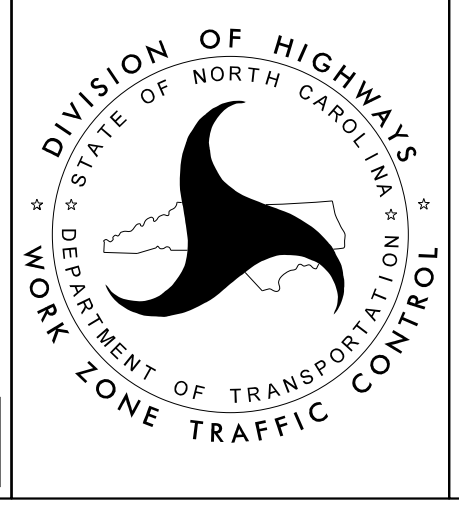

-L- NC 150  
 PHASE I  
 STEP 1

PROJ. REFERENCE NO.	SHEET NO.
R-2307B	TMP-37

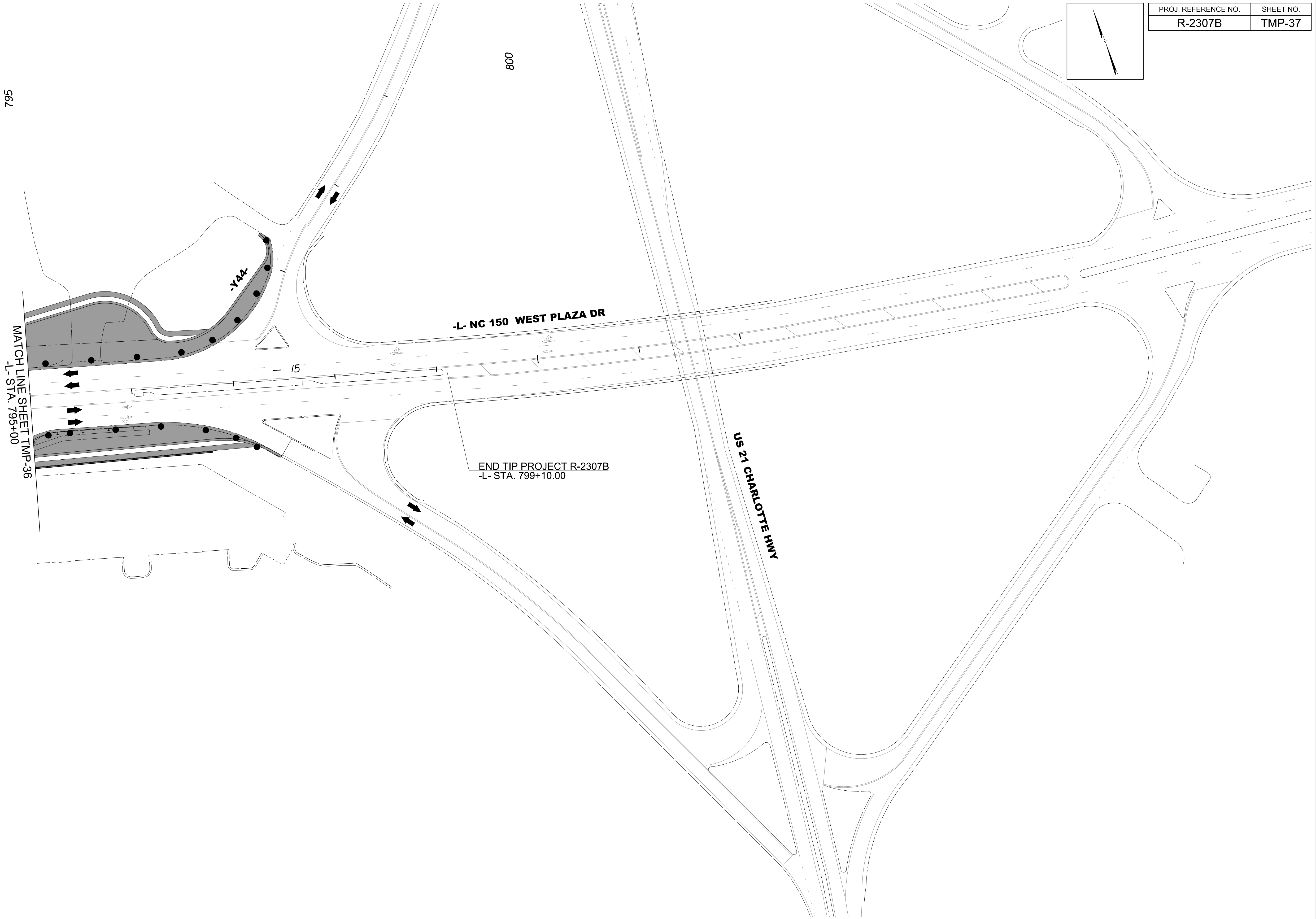
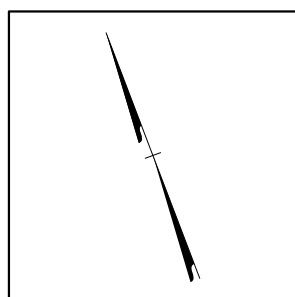

6/4/2024  
 U:\Traffic\Transportation Management\Plan\TCP\PLAN SHEETS\IR-2307B-TMP\_37\_PHASE\_01-STEP\_01.dgn  
 dorichardson

  
 Stantec Consulting Services Inc.  
 801 Jones Franklin Road  
 Suite 300  
 Raleigh, NC 27606  
 Tel. 919.851.6866  
 Fax. 919.851.7024  
 www.stantec.com  
 License No. F-0672

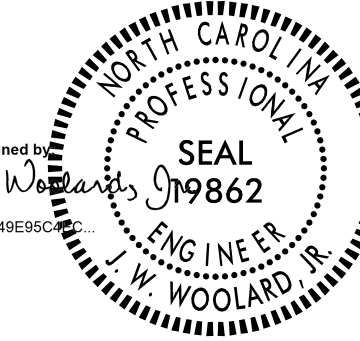
DocuSigned by  
  
 7/24/2024  
**DOCUMENT NOT CONSIDERED FINAL  
 UNLESS ALL SIGNATURES COMPLETED**

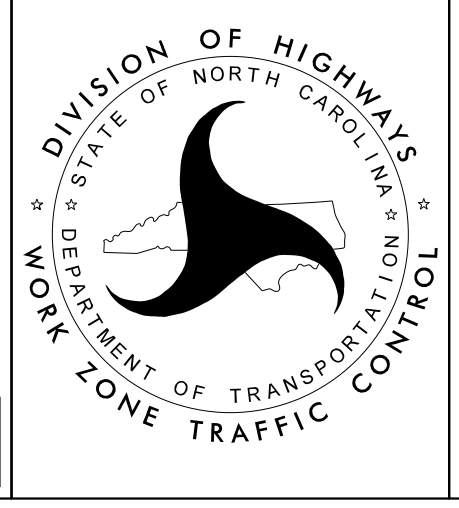

-L- NC 150  
 PHASE I  
 STEP 1

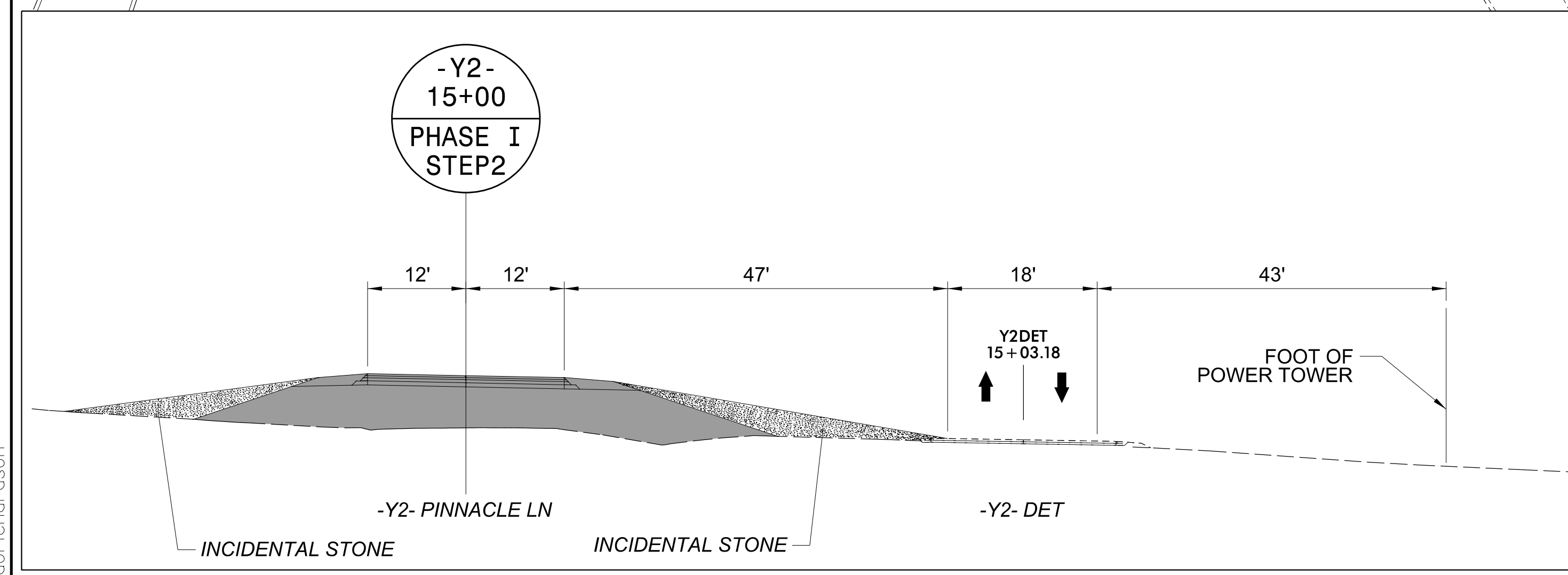
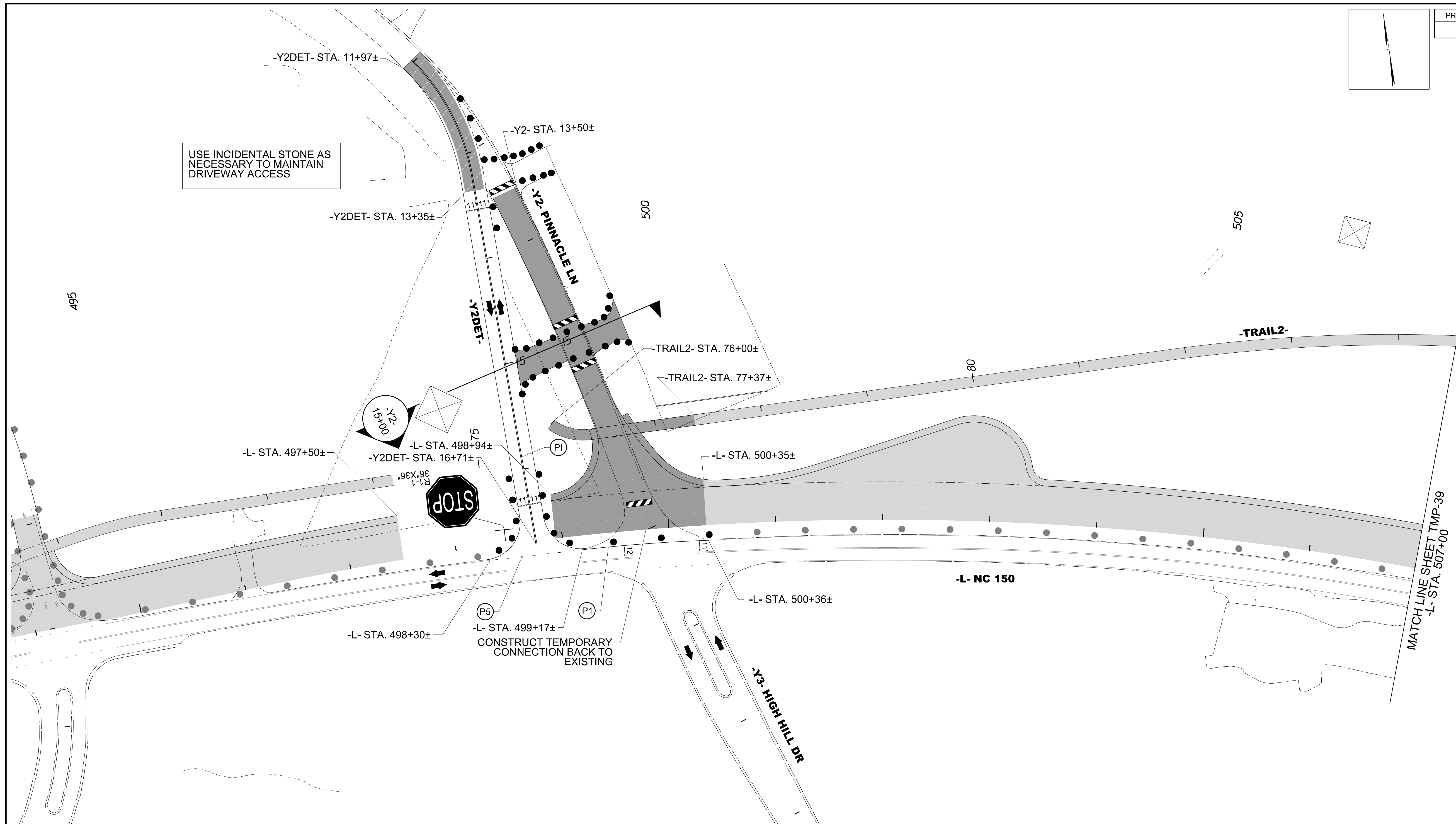
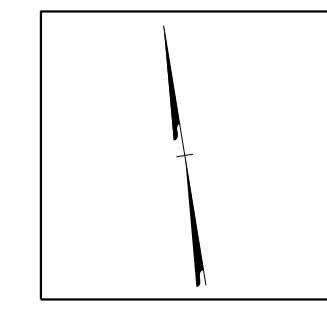

6/4/2024  
 U:\Traffic\Transportation Management Plan\TCP\PLAN SHEETS\R-2307B-TMP\_38\_PHASE\_01-STEP\_02.dgn  
 dorichardson

**Stantec**  
 Stantec Consulting Services Inc.  
 801 Jones Franklin Road  
 Suite 300  
 Raleigh, NC 27606  
 Tel. 919.851.6866  
 Fax. 919.851.7024  
 www.stantec.com  
 License No. F-0672

DocuSigned by  
 J.W. Woolard  
 7/24/2024

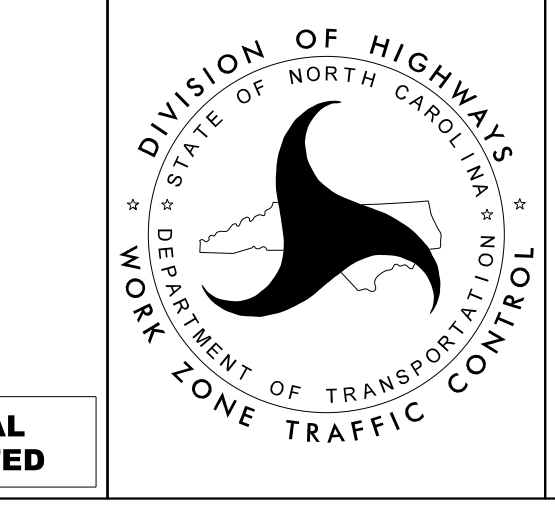

-L- NC 150  
 PHASE I  
 STEP 2

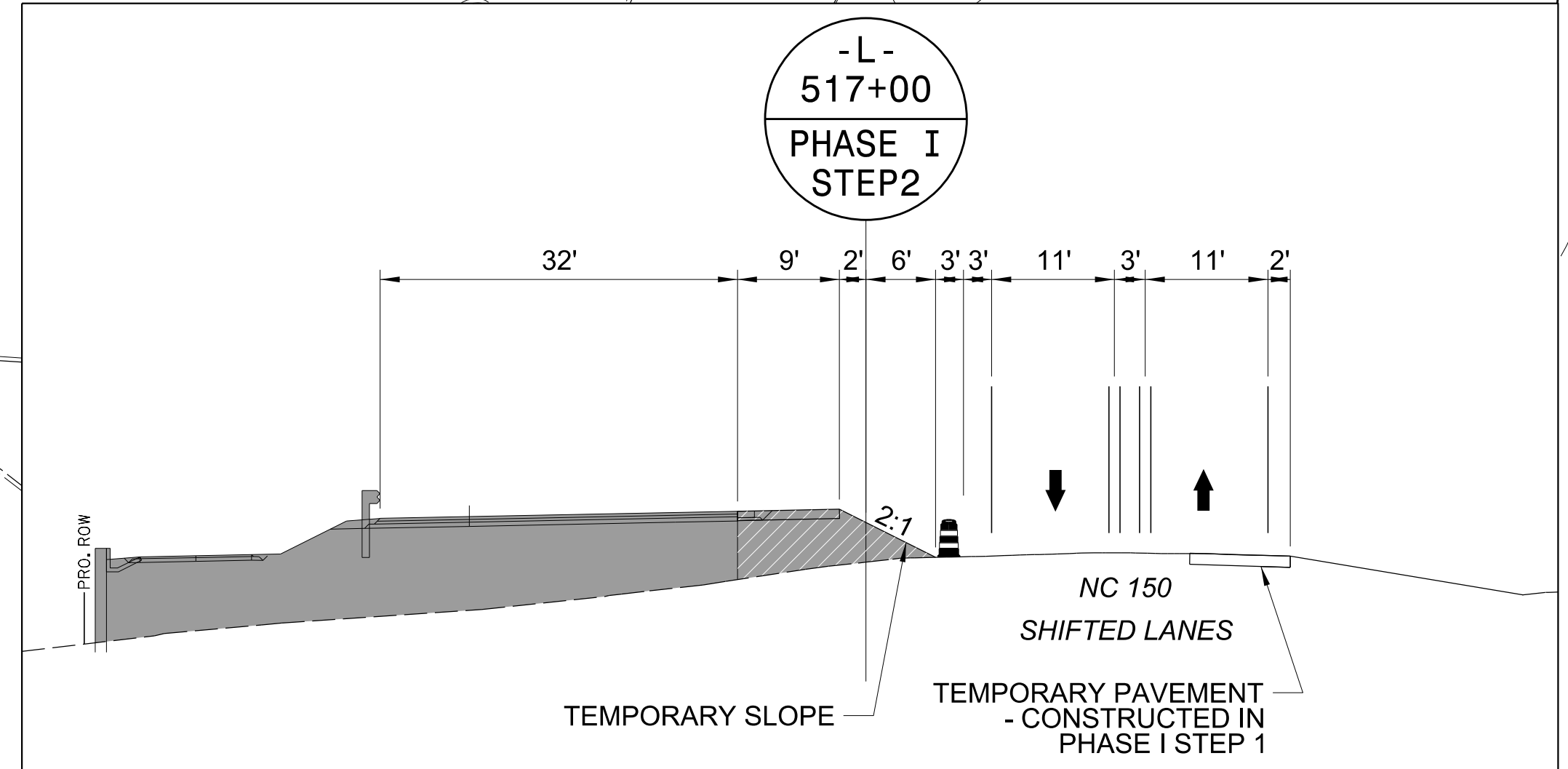
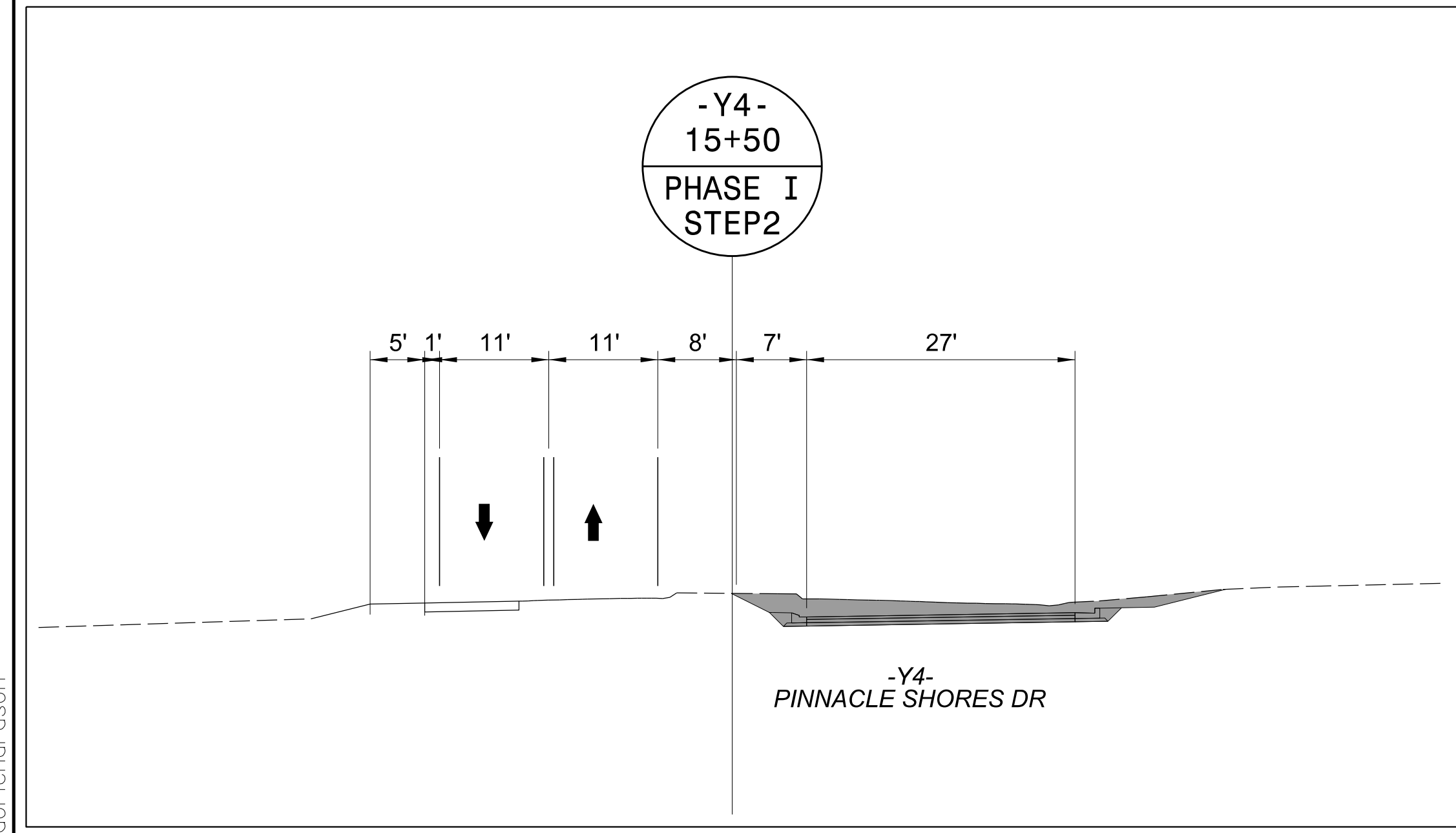
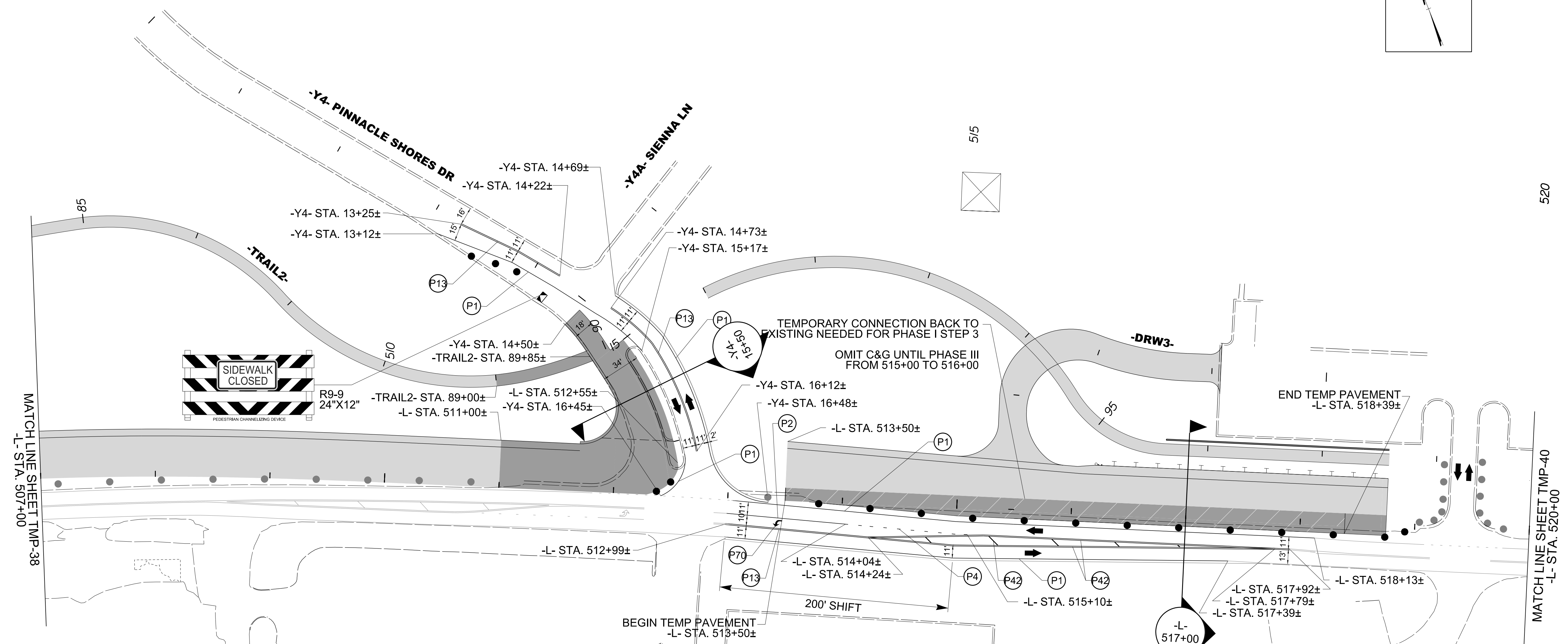
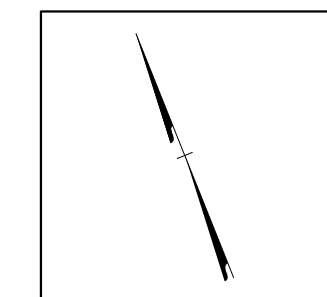

6/4/2024  
 U:\Traffic\Transportation Management\Plan\TCP\PLAN SHEETS\IR-2307B-TMP\_39\_PHASE\_01-STEP\_02.dgn  
 dorichardson

**Stantec**  
 Stantec Consulting Services Inc.  
 801 Jones Franklin Road  
 Suite 300  
 Raleigh, NC 27606  
 Tel. 919.851.6866  
 Fax. 919.851.7024  
 www.stantec.com  
 License No. F-0672

DocuSigned by  
  
 7/24/2024  
**DOCUMENT NOT CONSIDERED FINAL  
 UNLESS ALL SIGNATURES COMPLETED**

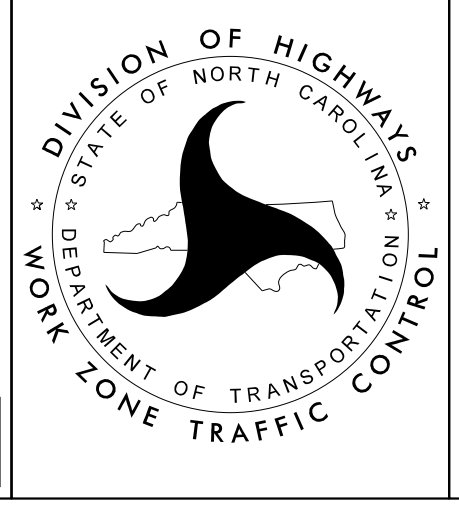

-L- NC 150  
PHASE I  
STEP 2

PROJ. REFERENCE NO.	SHEET NO.
R-2307B	TMP-40

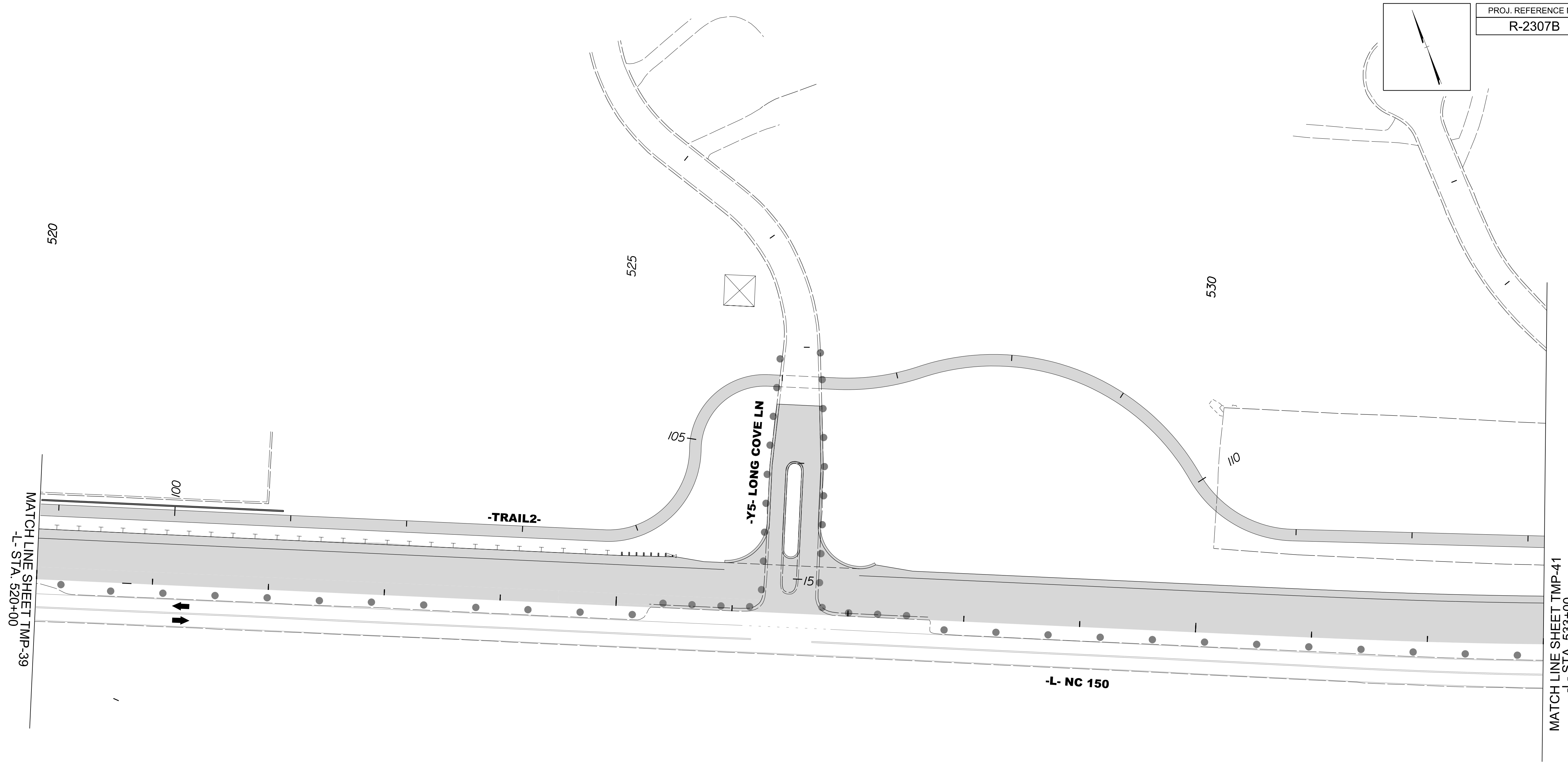
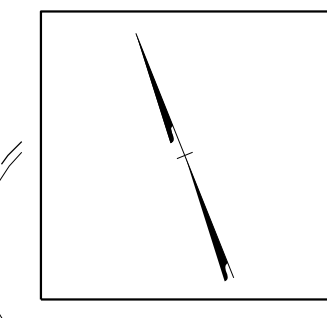

6/4/2024  
 U:\Traffic\Transportation Management\Plan\TCP\PLAN SHEETS\IR-2307B-TMP\_40\_PHASE\_01\_STEP\_02.dgn  
 dorichardson

**Stantec**  
 Stantec Consulting Services Inc.  
 801 Jones Franklin Road  
 Suite 300  
 Raleigh, NC 27606  
 Tel. 919.851.6866  
 Fax. 919.851.7024  
 www.stantec.com  
 License No. F-0672

DocuSigned by  
 J.W. Woolard  
 7/24/2024

SEAL  
 PROFESSIONAL ENGINEER  
 J. W. WOOLARD, R.  
 19862

**DOCUMENT NOT CONSIDERED FINAL  
 UNLESS ALL SIGNATURES COMPLETED**

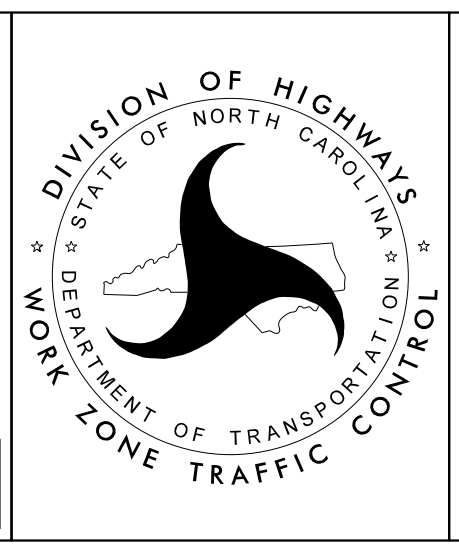

**-L- NC 150  
 PHASE I  
 STEP 2**

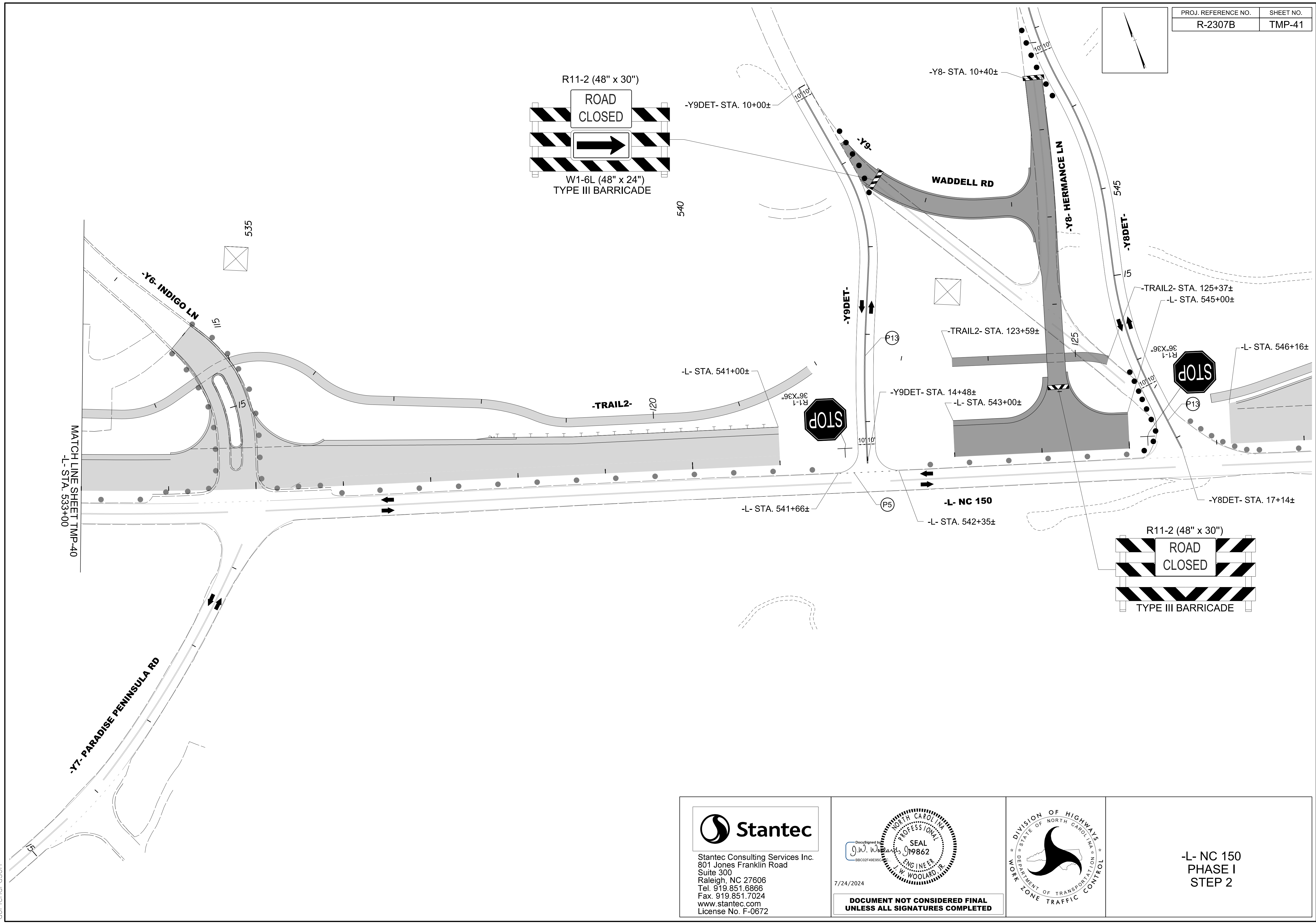
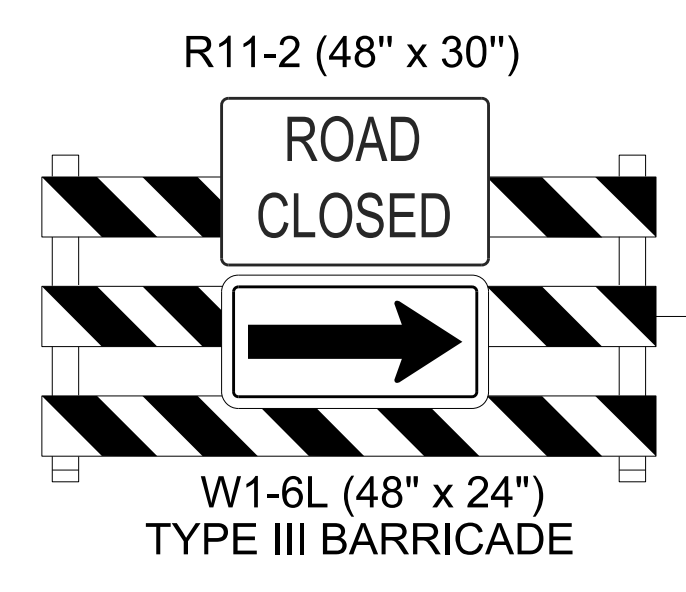
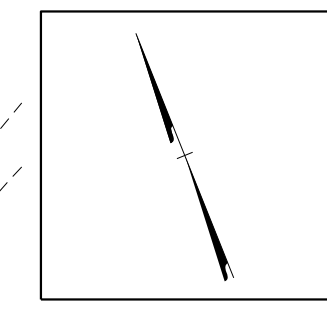

6/4/2024  
 U:\Traffic\Transportation Management\Plan\TCP\PLAN SHEETS\IR-2307B-TMP-41\PHASE.01\_STEP\_02.dgn  
 dorichardson

Stantec Consulting Services Inc.  
 801 Jones Franklin Road  
 Suite 300  
 Raleigh, NC 27606  
 Tel. 919.851.6866  
 Fax. 919.851.7024  
 www.stantec.com  
 License No. F-0672

DocuSigned by  
 J.W. Woolard  
 9802749690

7/24/2024

**DOCUMENT NOT CONSIDERED FINAL  
UNLESS ALL SIGNATURES COMPLETED**

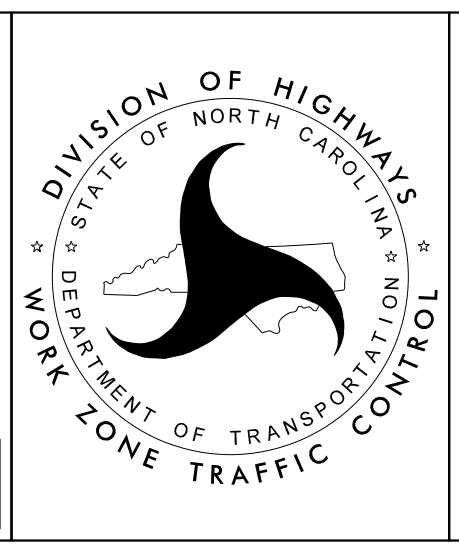

**-L- NC 150  
 PHASE I  
 STEP 2**

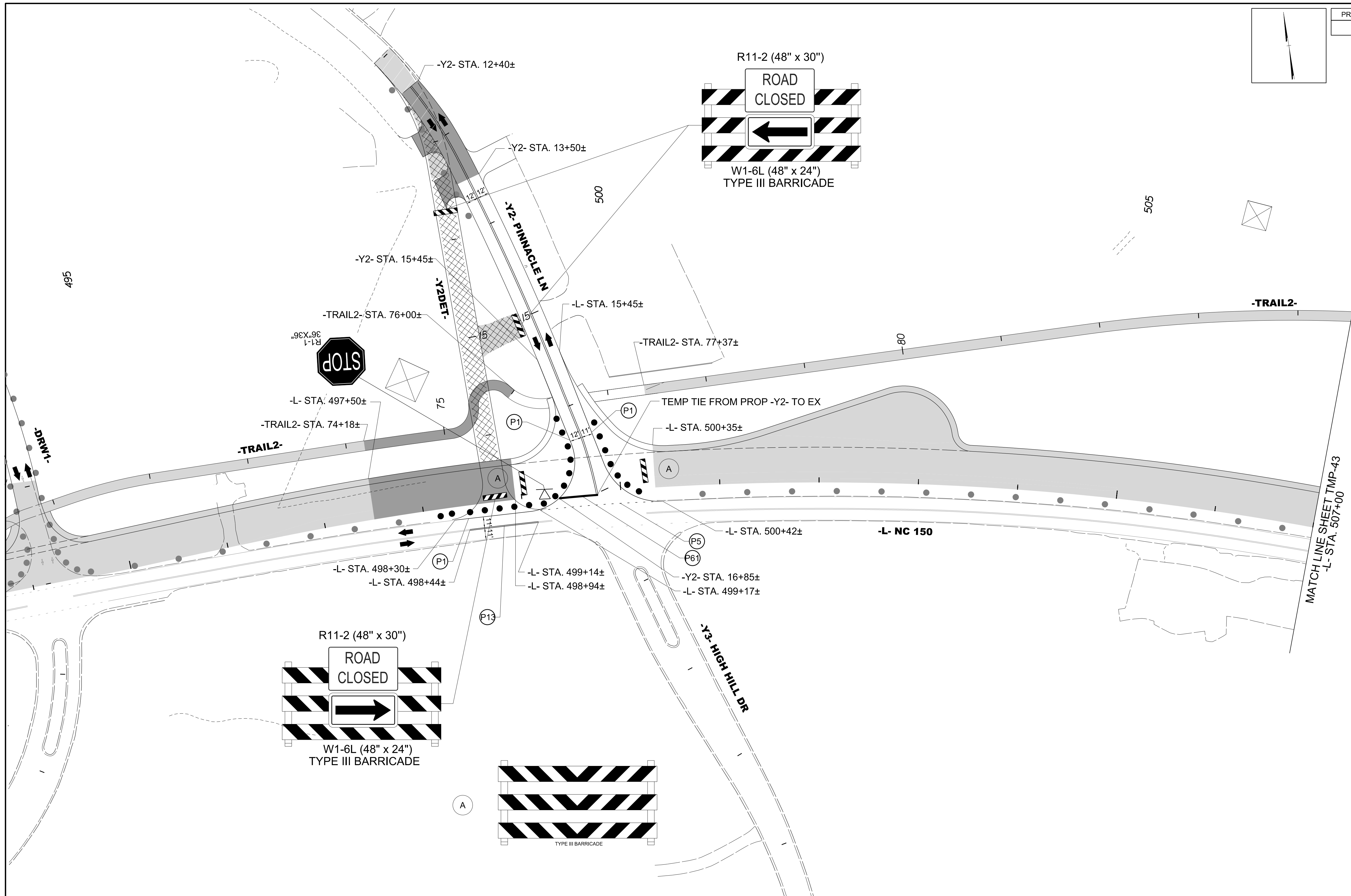
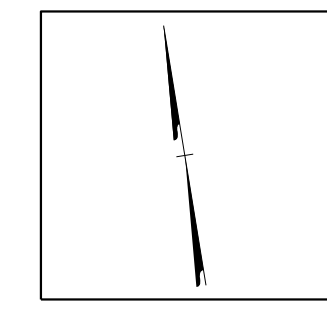

6/4/2024  
 U:\Traffic\Transportation Management\Plan\TCP\PLAN SHEETS\R-2307B-TMP-42\_PHASE\_01-STEP\_03.dgn  
 dorichardson

Stantec Consulting Services Inc.  
 801 Jones Franklin Road  
 Suite 300  
 Raleigh, NC 27606  
 Tel. 919.851.6866  
 Fax. 919.851.7024  
 www.stantec.com  
 License No. F-0672

DocuSigned by  
 J.W. Woolard  
 7/24/2024

DIVISION OF HIGHWAYS  
 NORTH CAROLINA  
 DEPARTMENT OF TRANSPORTATION  
 WORK ZONE TRAFFIC CONTROL

**-L- NC 150  
 PHASE I  
 STEP 3**

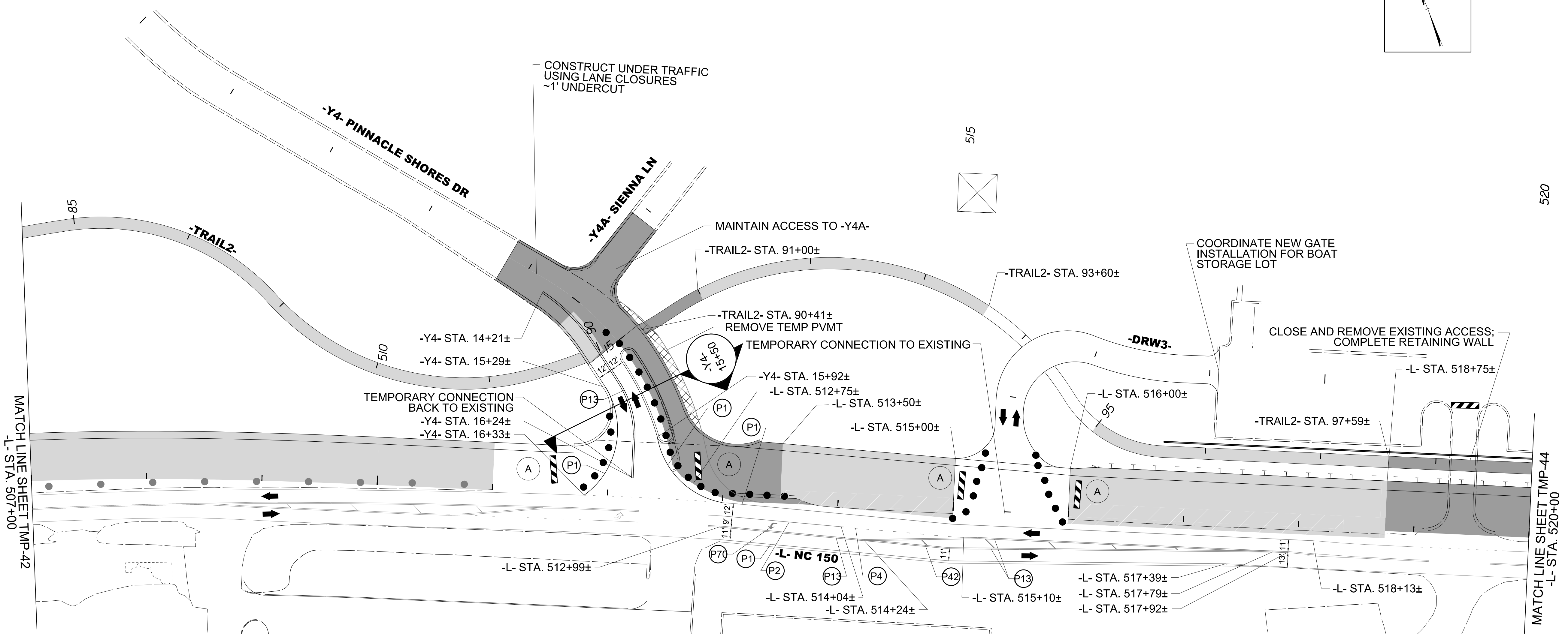
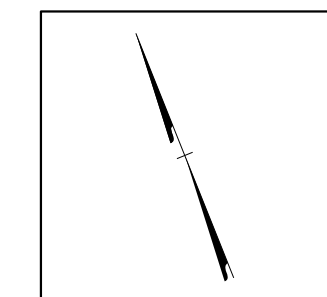

MATCH LINE SHEET TMP-42  
-L- STA. 507+00

MATCH LINE SHEET TMP-44  
-L- STA. 520+00

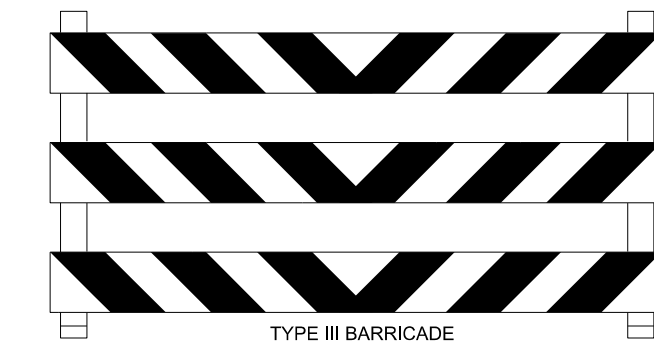
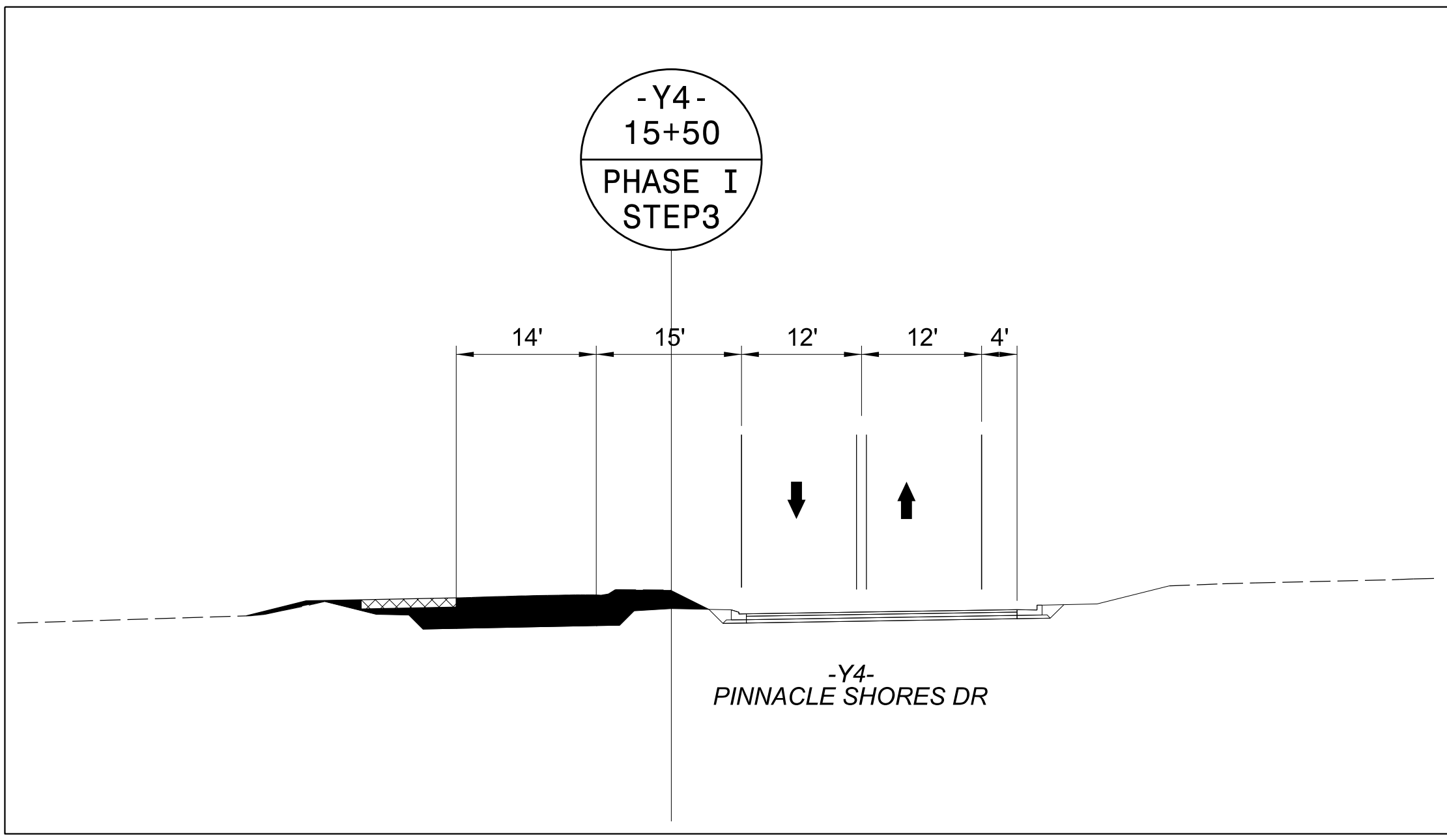

6/4/2024  
U:\Traffic\Transportation Management Plan\TCP\PLAN SHEETS\IR-2307B-TMP-43\_PHASE\_01-STEP\_03.dgn  
dorichardson

**Stantec**  
Stantec Consulting Services Inc.  
801 Jones Franklin Road  
Suite 300  
Raleigh, NC 27606  
Tel. 919.851.6866  
Fax. 919.851.7024  
www.stantec.com  
License No. F-0672

DocuSigned by  
*J.W. Woolard*  
7/24/2024

SEAL  
J.W. WOOLARD, R.  
ENGINEER  
19862

**DOCUMENT NOT CONSIDERED FINAL  
UNLESS ALL SIGNATURES COMPLETED**

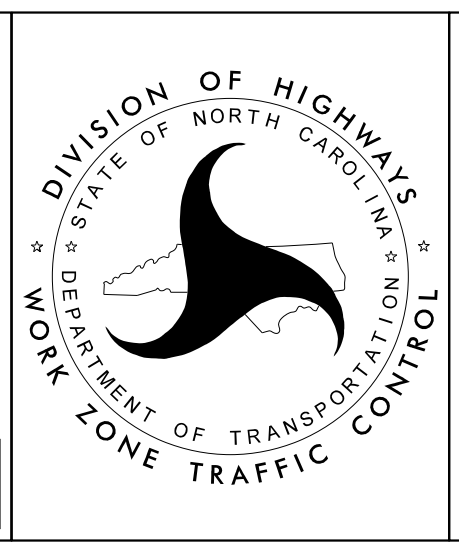

-L- NC 150  
PHASE I  
STEP 3



PROJ. REFERENCE NO.	SHEET NO.
R-2307B	TMP-44

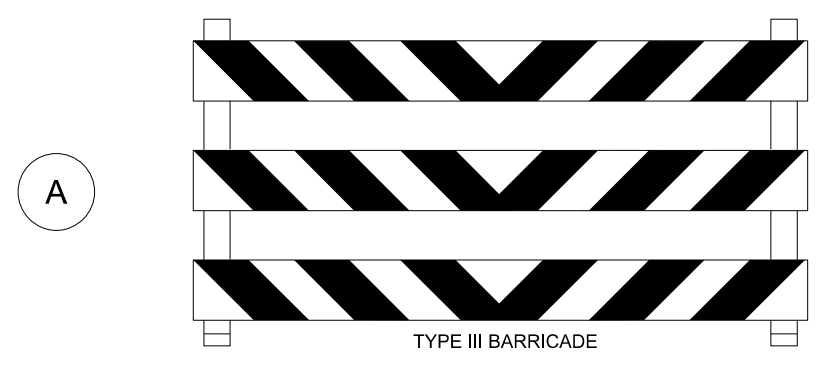
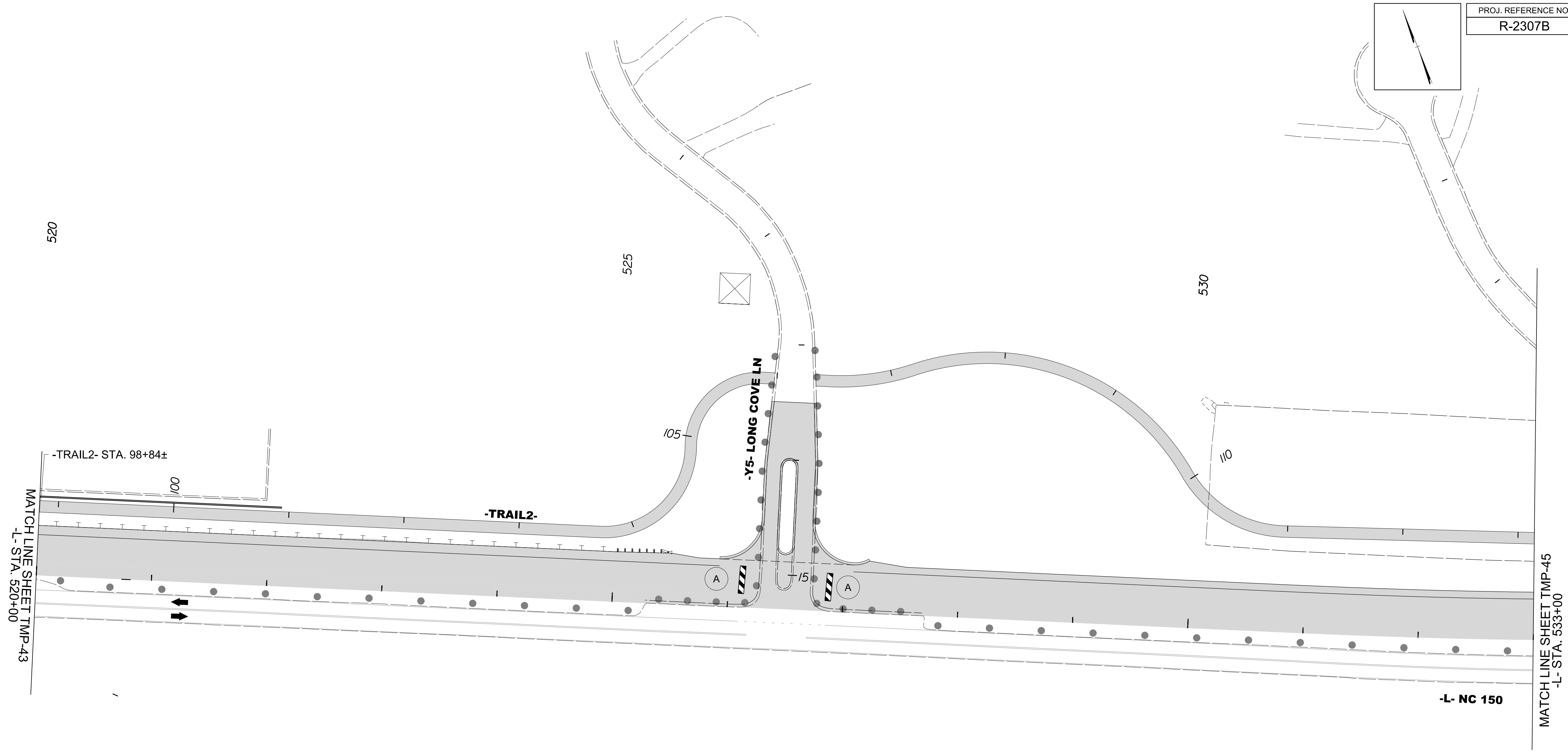
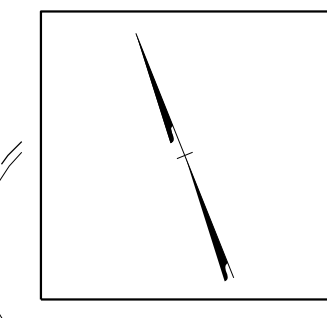

6/4/2024  
 U:\Traffic\Transportation Management\Plan\TCP\PLAN SHEETS\IR-2307B-TMP-44\_PHASE\_01\_STEP\_03.dgn  
 dorichardson



Stantec Consulting Services Inc.  
 801 Jones Franklin Road  
 Suite 300  
 Raleigh, NC 27606  
 Tel. 919.851.6866  
 Fax. 919.851.7024  
 www.stantec.com  
 License No. F-0672



**DOCUMENT NOT CONSIDERED FINAL  
 UNLESS ALL SIGNATURES COMPLETED**

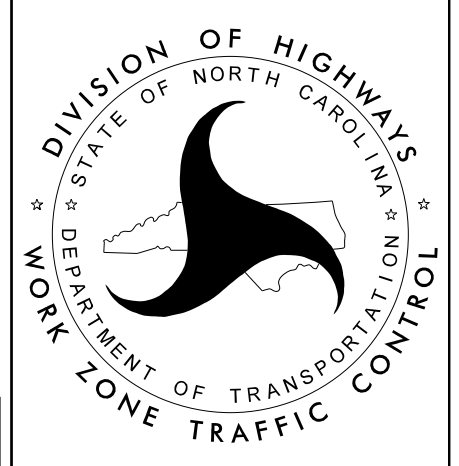

**-L- NC 150  
 PHASE I  
 STEP 3**

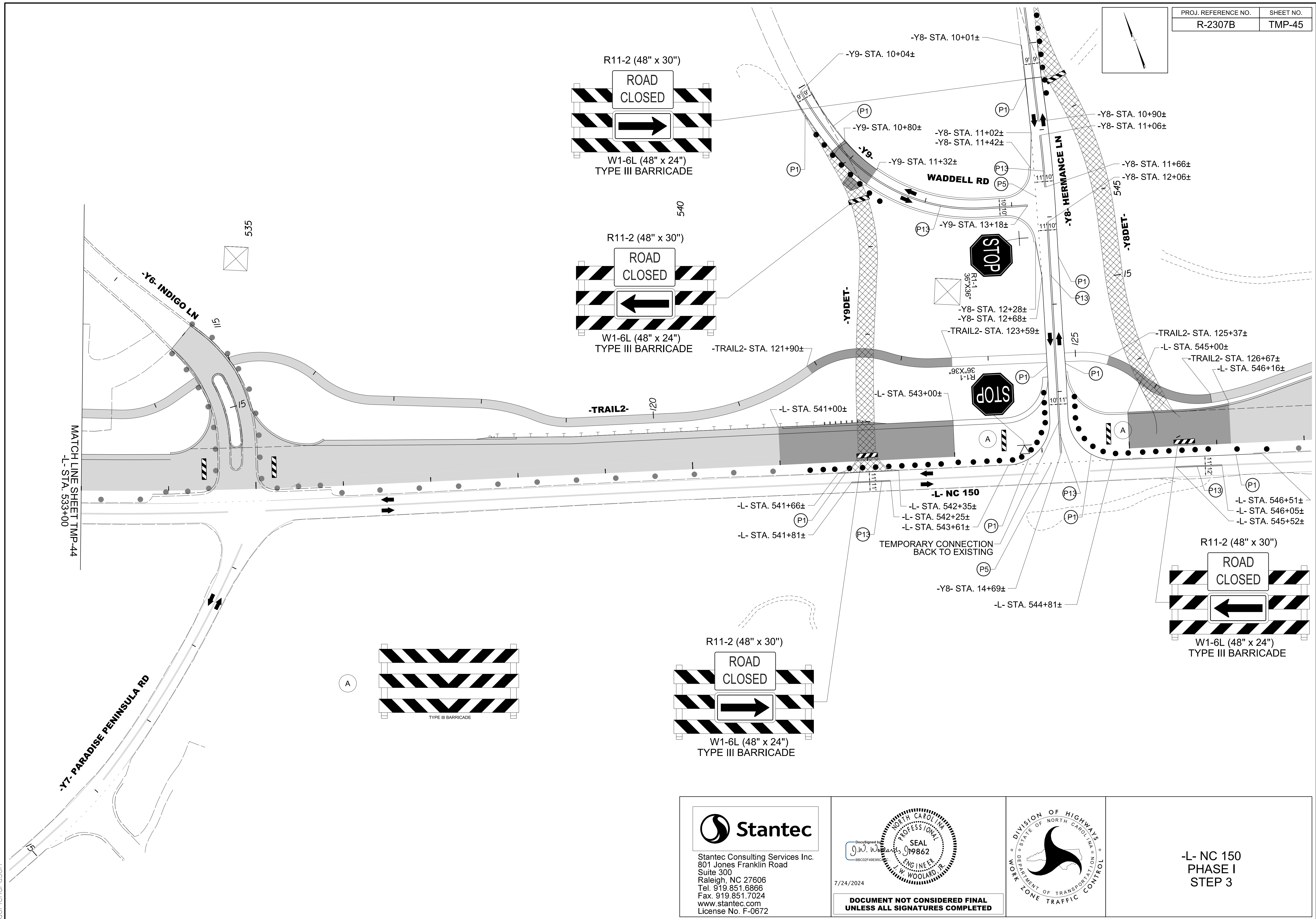

6/4/2024  
 U:\Traffic\Transportation Management\Plan\TCP\PLAN SHEETS\IR-2307B-TMP-45\_PHASE\_01\_STEP\_03.dgn  
 dorichardson

**Stantec**  
 Stantec Consulting Services Inc.  
 801 Jones Franklin Road  
 Suite 300  
 Raleigh, NC 27606  
 Tel. 919.851.6866  
 Fax. 919.851.7024  
 www.stantec.com  
 License No. F-0672

DocuSigned by:  
 J.W. Woolard, P.E.  
 7/24/2024

SEAL  
 J.W. WOOLARD, P.E.  
 19862  
 PROFESSIONAL ENGINEER  
 NORTH CAROLINA

DOCUMENT NOT CONSIDERED FINAL  
 UNLESS ALL SIGNATURES COMPLETED

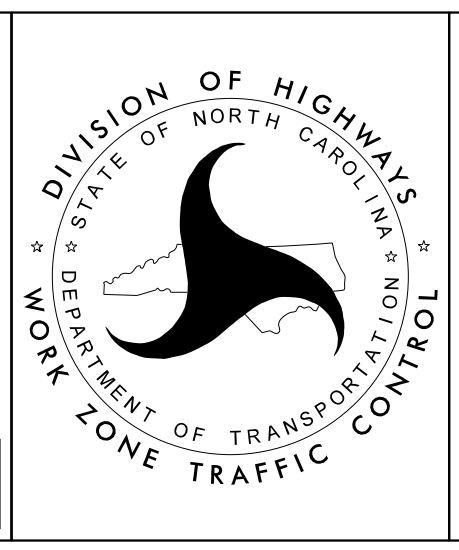

-L- NC 150  
 PHASE I  
 STEP 3

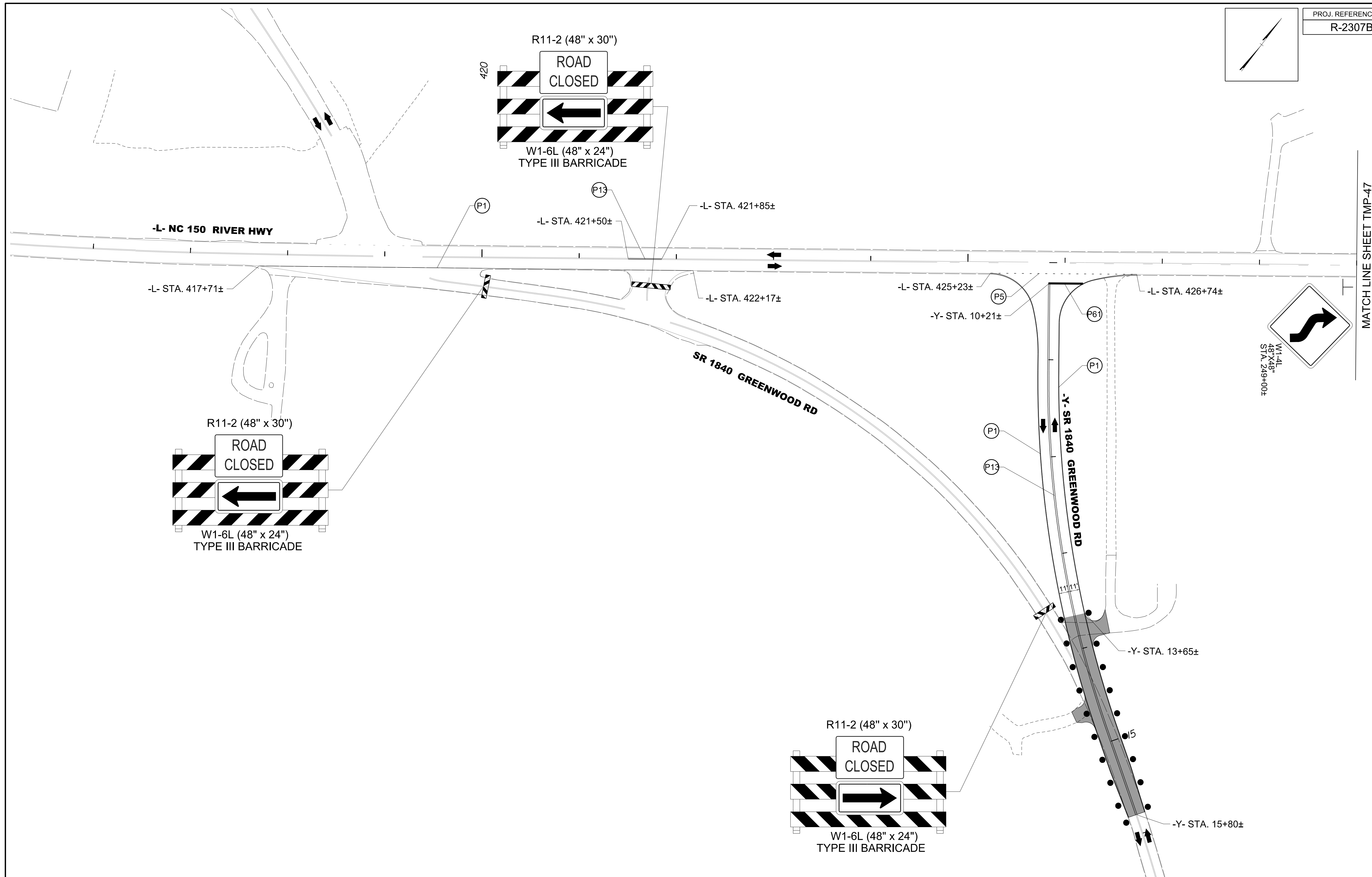
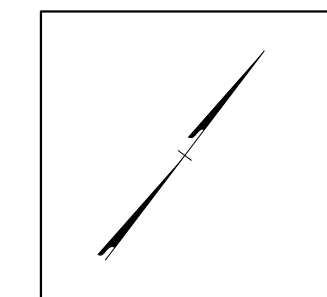

6/4/2024  
 U:\Traffic\Transportation Management\Plan\TCP\PLAN SHEETS\IR-2307B-TMP-46\_PHASE-02\_STEP-01.dgn  
 dorichardson

  
 Stantec Consulting Services Inc.  
 801 Jones Franklin Road  
 Suite 300  
 Raleigh, NC 27606  
 Tel. 919.851.6866  
 Fax. 919.851.7024  
 www.stantec.com  
 License No. F-0672

7/24/2024  
  
**DOCUMENT NOT CONSIDERED FINAL  
 UNLESS ALL SIGNATURES COMPLETED**

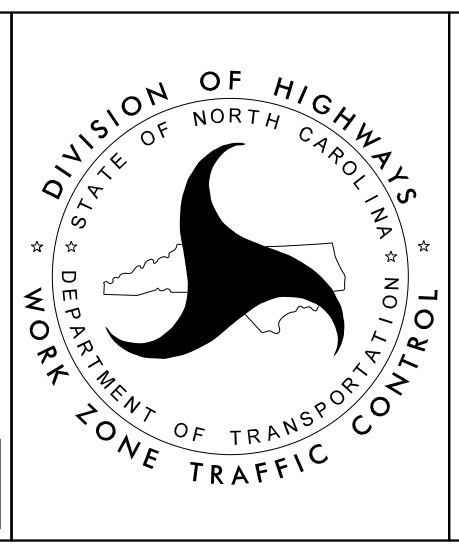

**-L- NC 150  
 PHASE II  
 STEP 1**

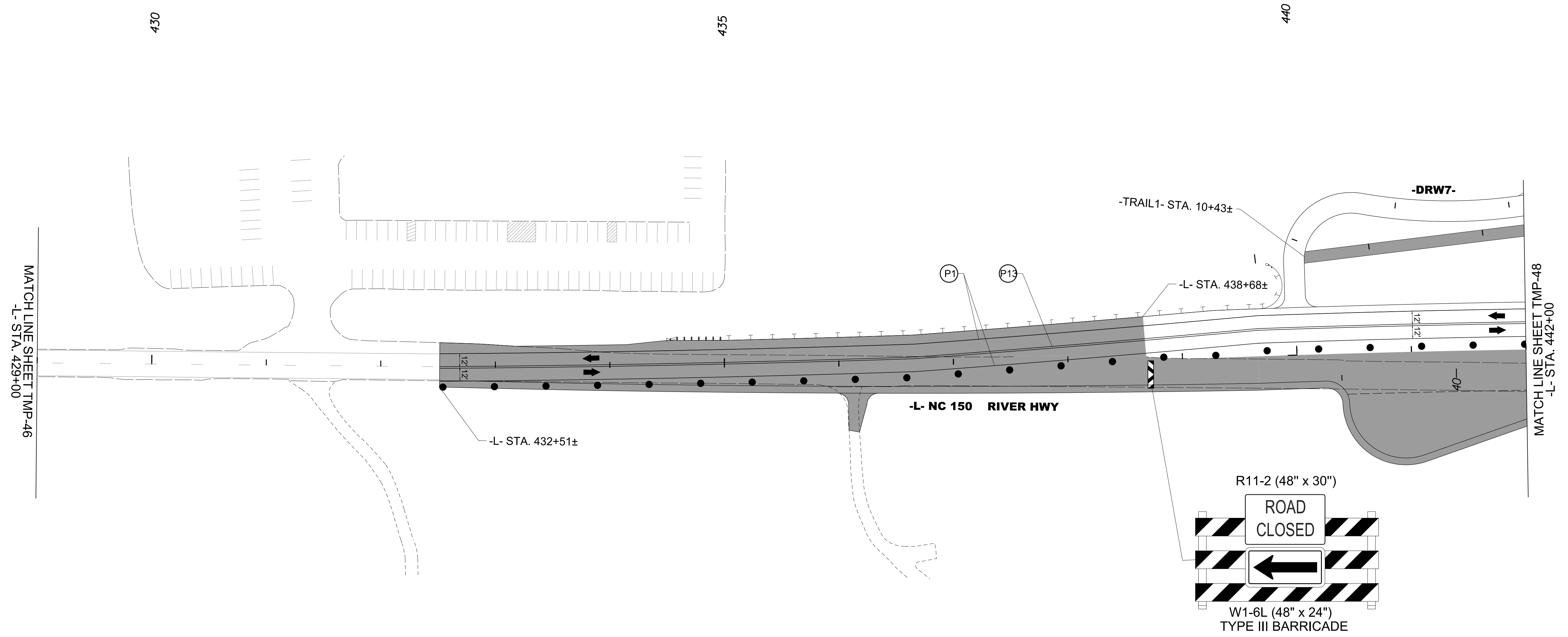
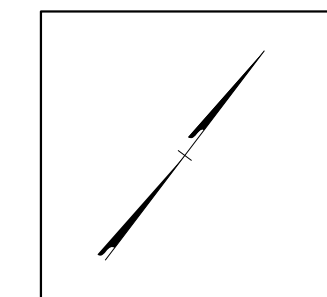

6/4/2024  
 U:\Traffic\Transportation Management\Plan\TCP\PLAN SHEETS\IR-2307B-TMP-47\_PHASE\_02\_STEP\_01.dgn  
 dorichardson

Stantec Consulting Services Inc.  
 801 Jones Franklin Road  
 Suite 300  
 Raleigh, NC 27606  
 Tel. 919.851.6866  
 Fax. 919.851.7024  
 www.stantec.com  
 License No. F-0672

DocuSigned by  
*J.W. Woolard*  
 8BC02F49E950

7/24/2024

**DOCUMENT NOT CONSIDERED FINAL  
UNLESS ALL SIGNATURES COMPLETED**

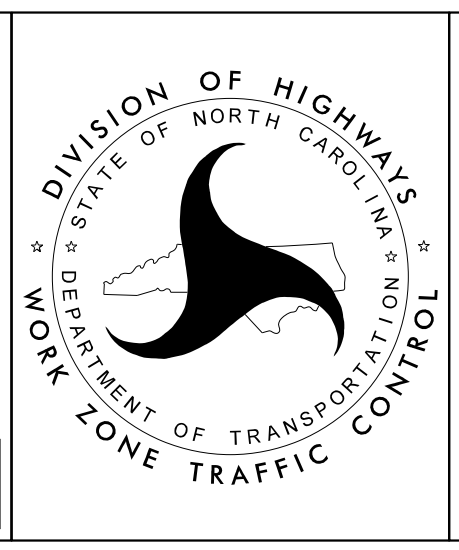

**-L- NC 150  
 PHASE II  
 STEP 1**

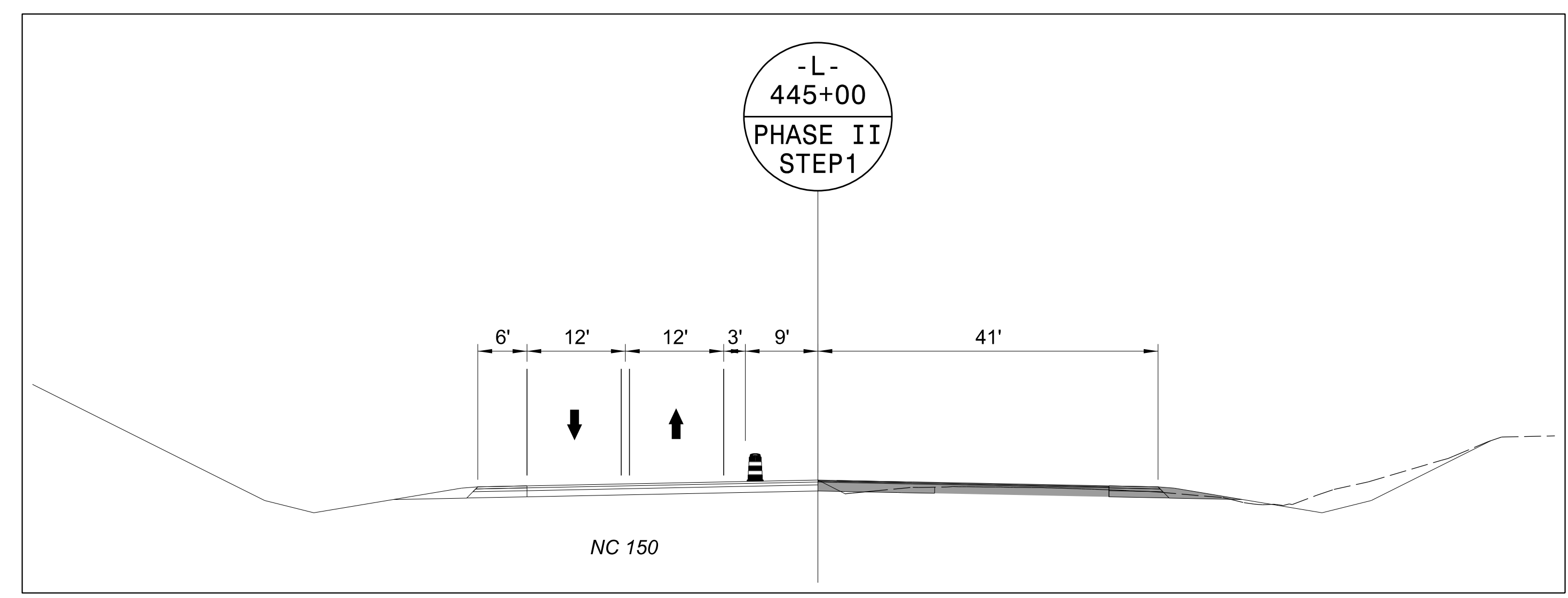
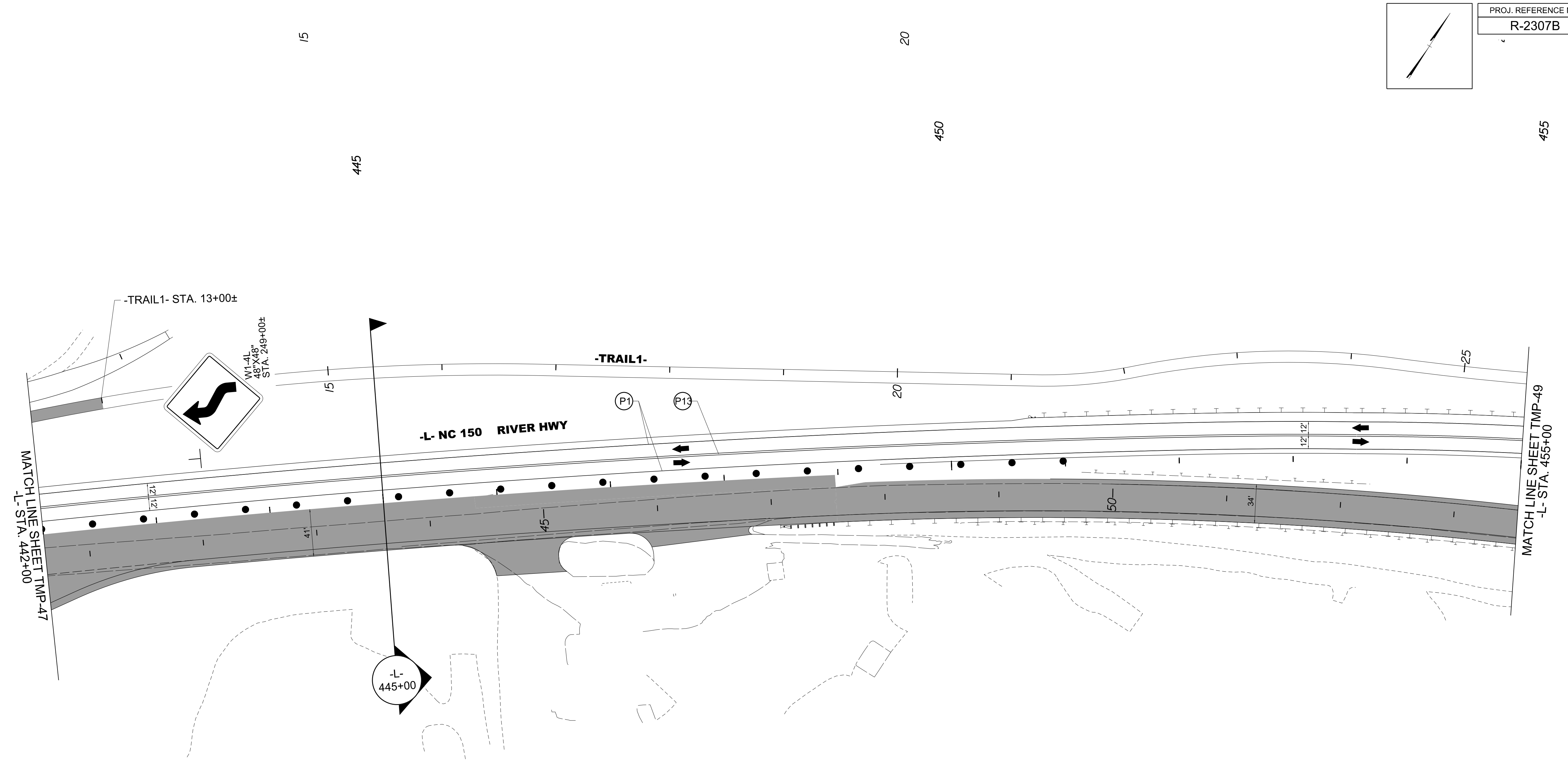
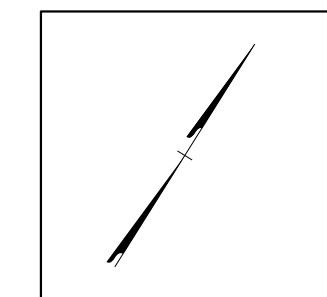

6/4/2024  
 U:\Traffic\Transportation Management Plan\TCP\PLAN SHEETS\IR-2307B-TMP-48\_PHASE\_02\_STEP\_01.dgn  
 dorichardson

**Stantec**  
 Stantec Consulting Services Inc.  
 801 Jones Franklin Road  
 Suite 300  
 Raleigh, NC 27606  
 Tel. 919.851.6866  
 Fax. 919.851.7024  
 www.stantec.com  
 License No. F-0672

DocuSigned by  
 J.W. Woolard  
 919862  
 SEAL  
 PROFESSIONAL ENGINEER  
 W. WOOLARD, P.E.  
 7/24/2024

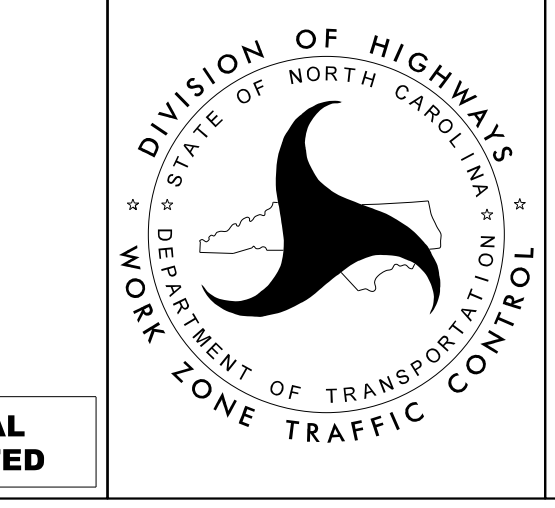

-L- NC 150  
 PHASE II  
 STEP 1

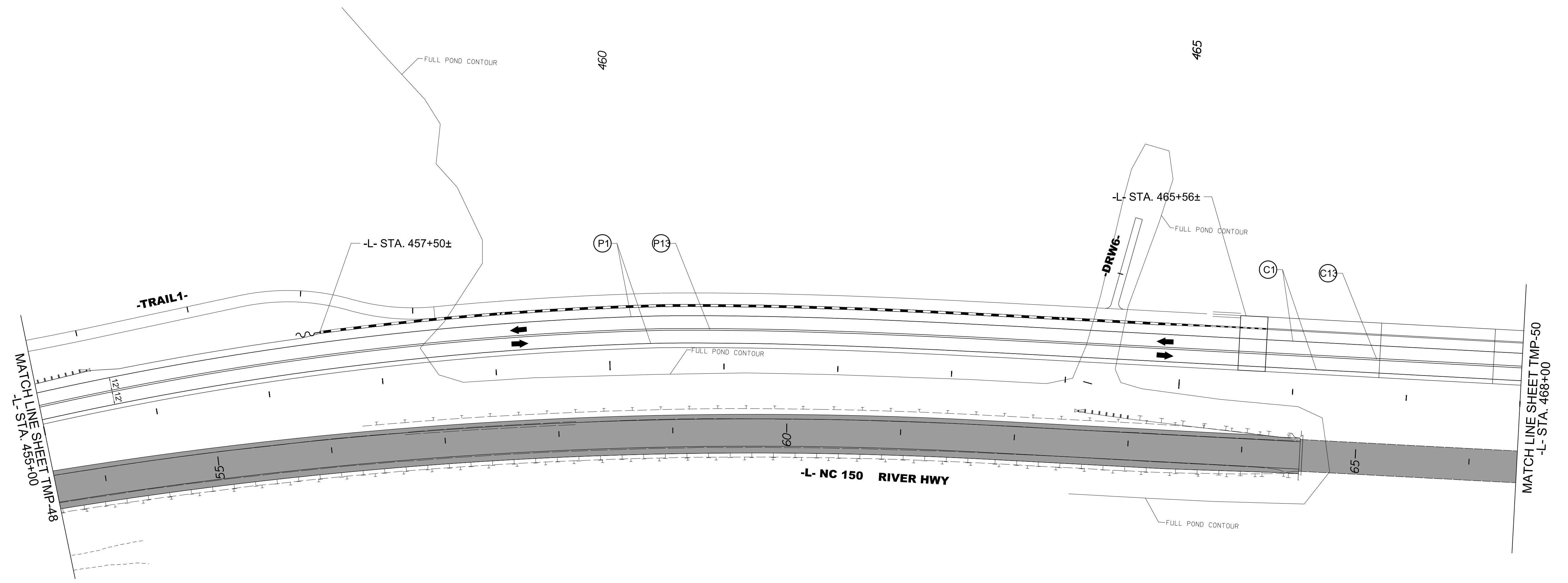
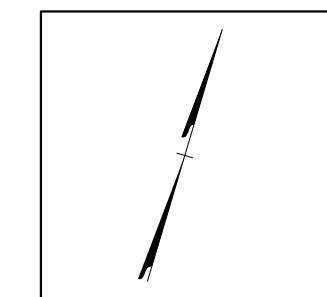

6/4/2024  
 U:\Traffic\Transportation Management\Plan\TCP\PLAN SHEETS\IR-2307B-TMP-49\_PHASE\_02\_STEP\_01.dgn  
 dorichardson

Stantec Consulting Services Inc.  
 801 Jones Franklin Road  
 Suite 300  
 Raleigh, NC 27606  
 Tel. 919.851.6866  
 Fax. 919.851.7024  
 www.stantec.com  
 License No. F-0672

DocuSigned by:  
  
 7/24/2024  
**DOCUMENT NOT CONSIDERED FINAL  
 UNLESS ALL SIGNATURES COMPLETED**

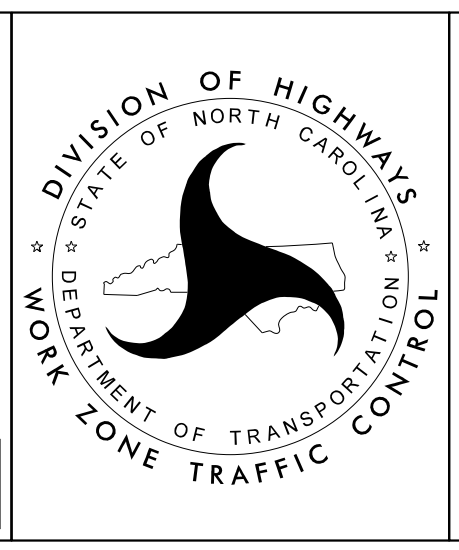

**-L- NC 150  
 PHASE II  
 STEP 1**

PROJ. REFERENCE NO.	SHEET NO.
R-2307B	TMP-50

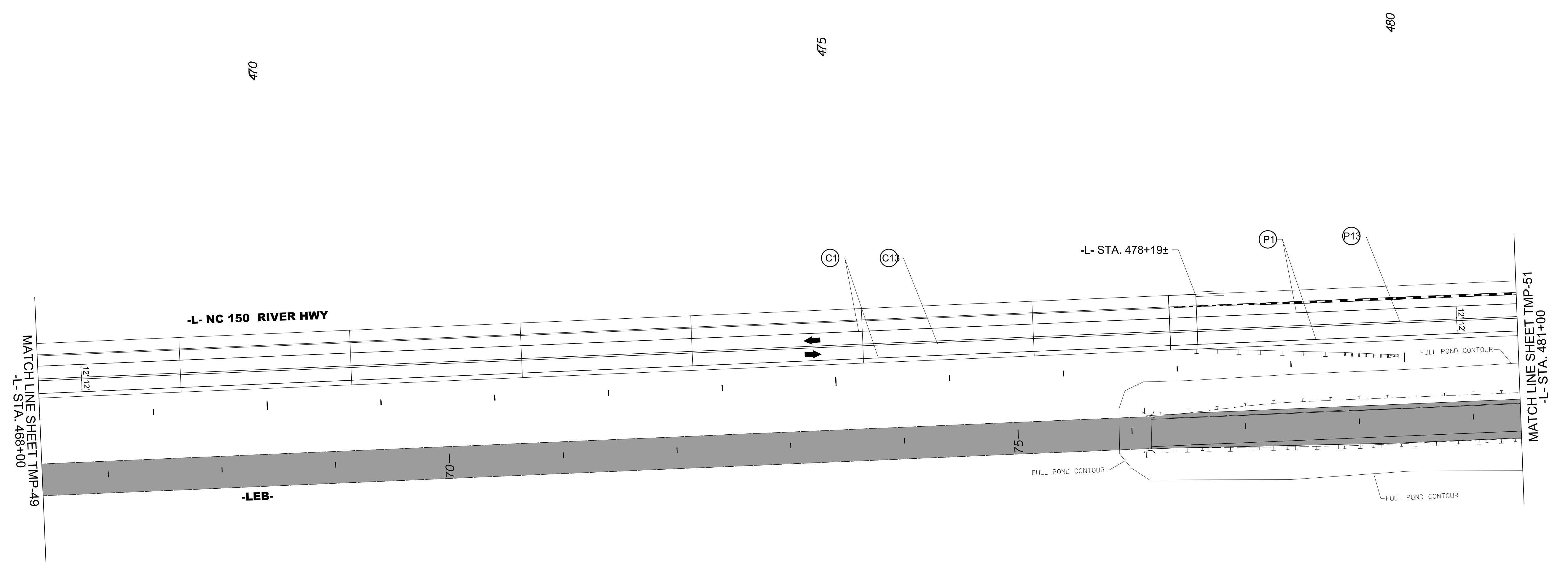
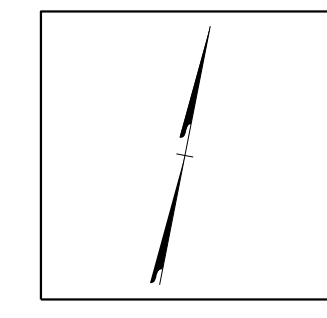

6/4/2024  
 U:\Traffic\Transportation Management\Plan\TCP\PLAN SHEETS\IR-2307B-TMP\_50\_PHASE\_02\_STEP\_01.dgn  
 dorichardson

Stantec Consulting Services Inc.  
 801 Jones Franklin Road  
 Suite 300  
 Raleigh, NC 27606  
 Tel. 919.851.6866  
 Fax. 919.851.7024  
 www.stantec.com  
 License No. F-0672

DocuSigned by  
*J.W. Woolard*  
 9802749690

7/24/2024

**DOCUMENT NOT CONSIDERED FINAL  
UNLESS ALL SIGNATURES COMPLETED**

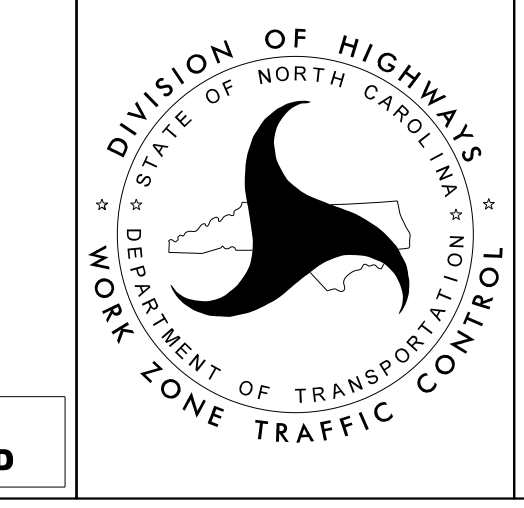

**-L- NC 150  
 PHASE II  
 STEP 1**

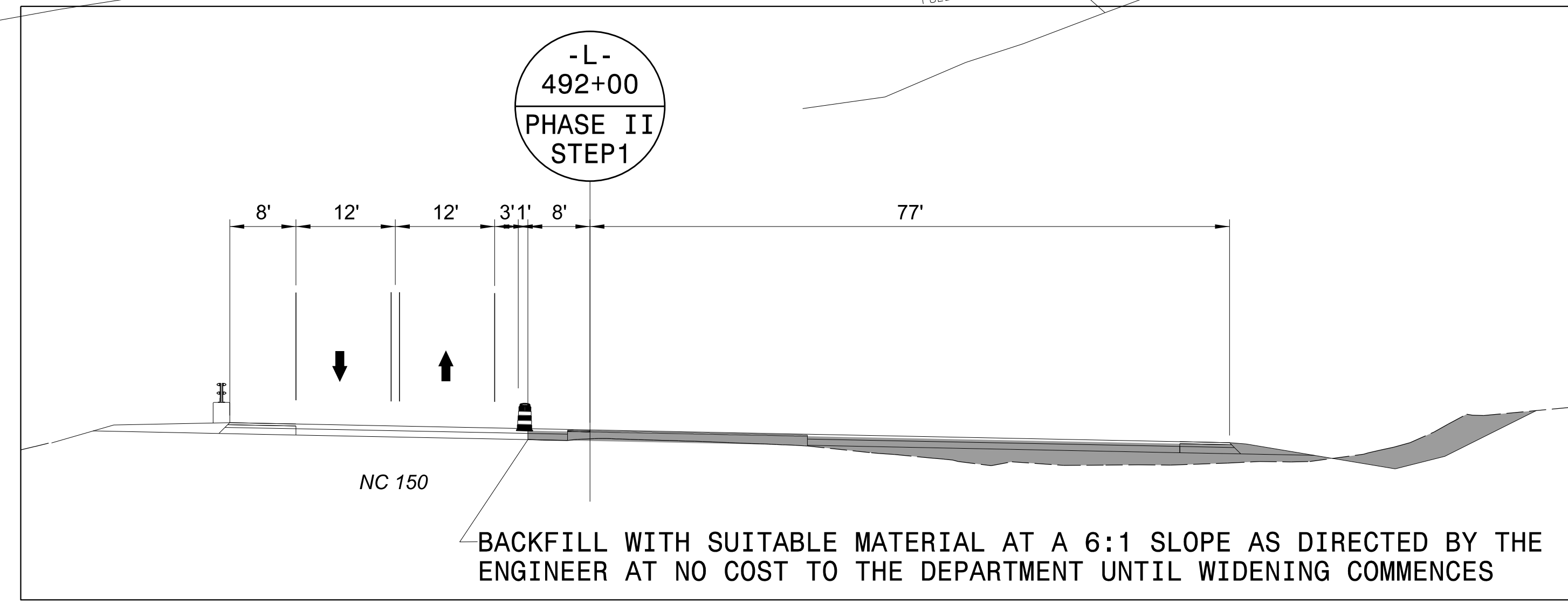
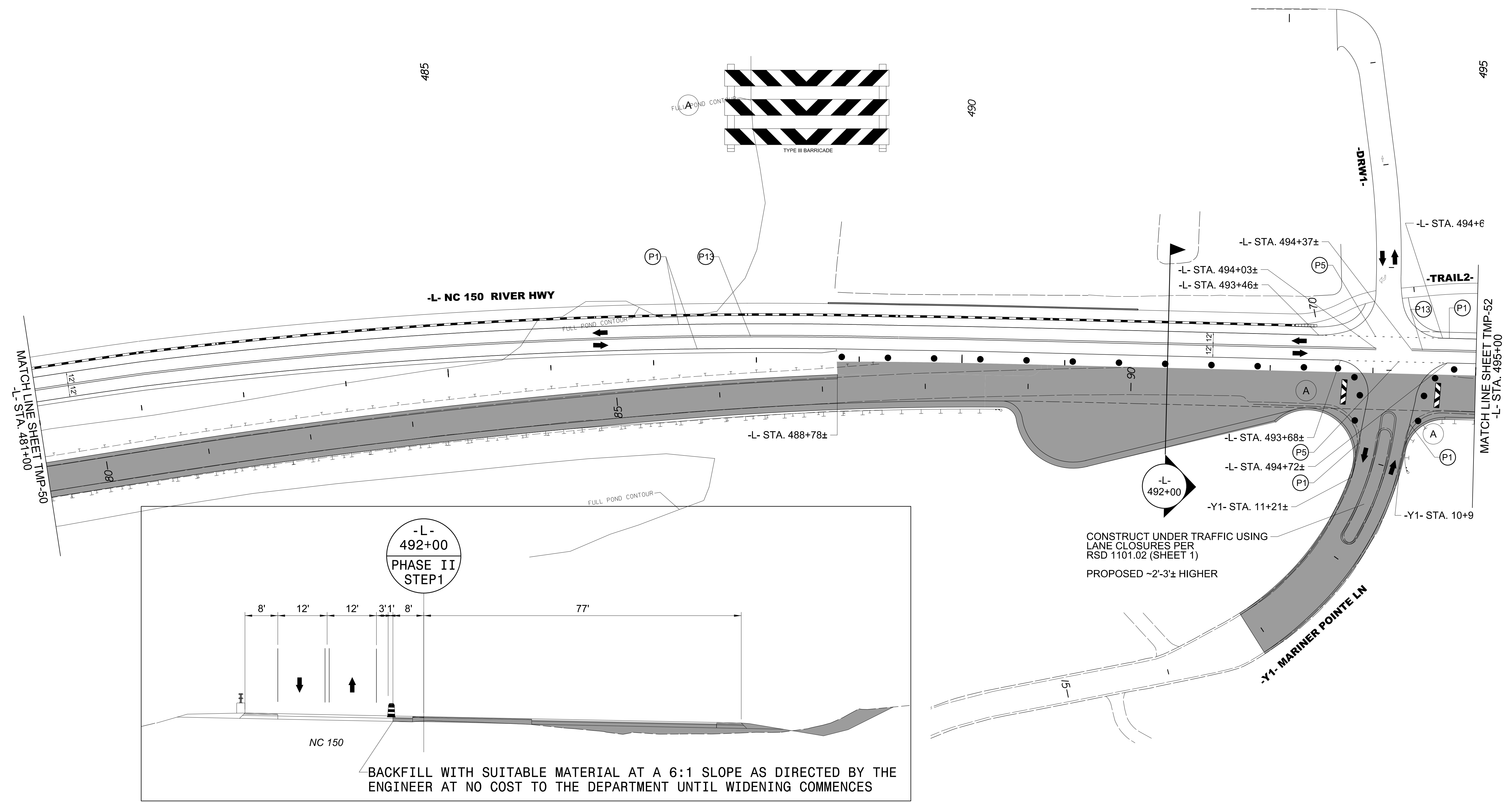

CONSTRUCT UNDER TRAFFIC USING  
LANE CLOSURES PER  
RSD 1101.02 (SHEET 1)  
PROPOSED ~2'-3'± HIGHER

6/4/2024  
U:\Traffic\Transportation Management Plan\TCP\PLAN SHEETS\VR-2307B-TMP-51\PHASE\_02\_STEP\_01.dgn  
dorichardson

**Stantec**  
Stantec Consulting Services Inc.  
801 Jones Franklin Road  
Suite 300  
Raleigh, NC 27606  
Tel. 919.851.6866  
Fax. 919.851.7024  
www.stantec.com  
License No. F-0672

DocuSigned by  
*J.W. Woolard*  
SEAL  
19862  
ENGINEER  
W. WOOLARD, R.  
7/24/2024

DIVISION OF HIGHWAYS  
STATE OF NORTH CAROLINA  
DEPARTMENT OF TRANSPORTATION  
WORK ZONE TRAFFIC CONTROL

-L- NC 150  
PHASE II  
STEP 1



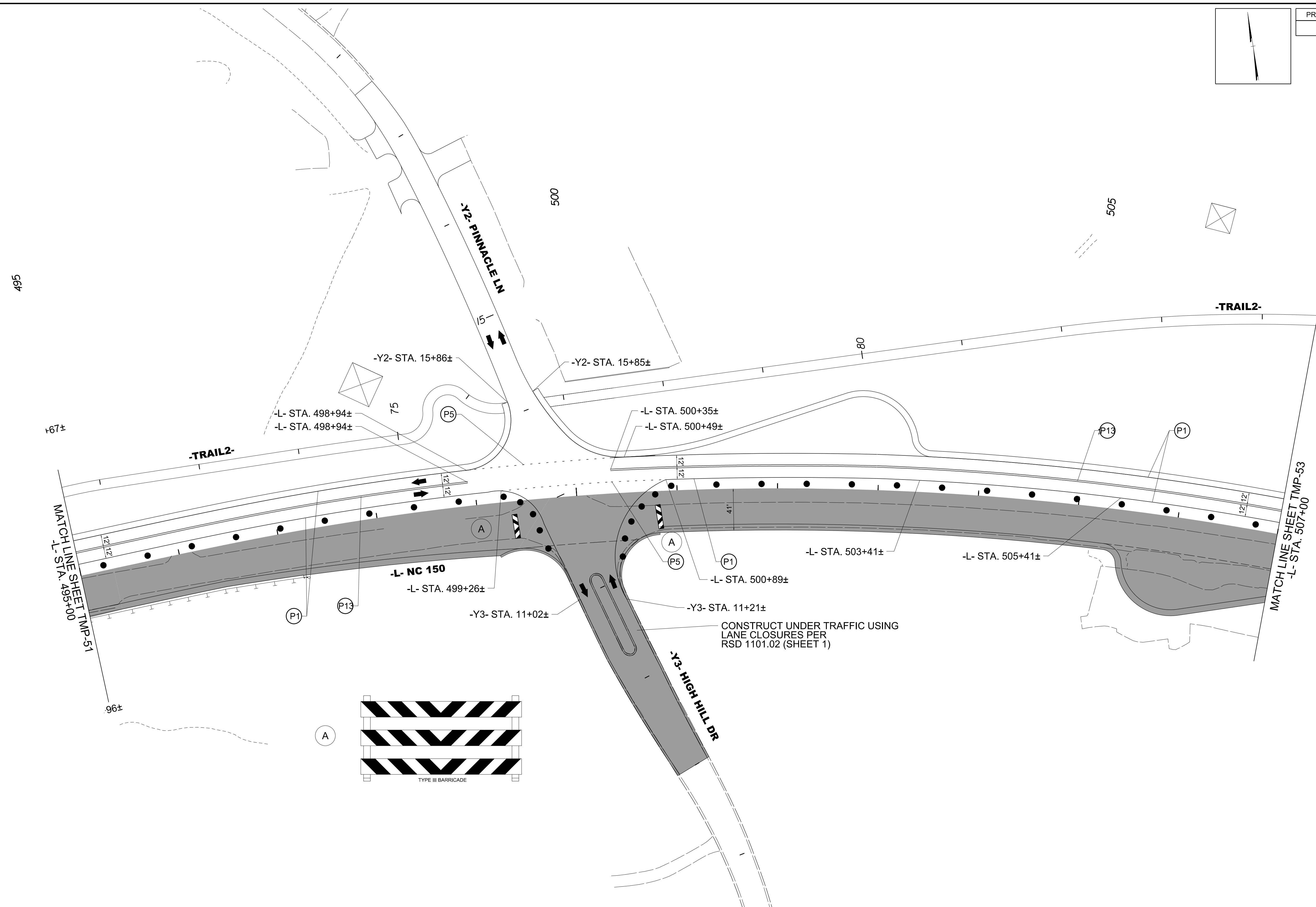
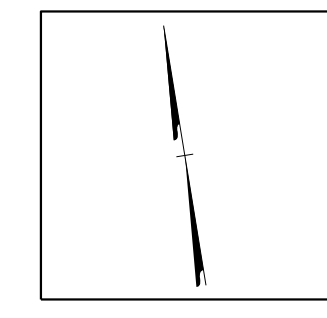

6/4/2024  
 U:\Traffic\Transportation Management\Plan\TCP\PLAN SHEETS\NR-2307B-TMP\_52\_PHASE\_02\_STEP\_01.dgn  
 dorichardson

<p>Stantec Consulting Services Inc.        801 Jones Franklin Road        Suite 300        Raleigh, NC 27606        Tel. 919.851.6866        Fax. 919.851.7024        www.stantec.com        License No. F-0672</p>	<p>DocuSigned by  <i>J.W. Woolard</i>        8BC02F49E950</p> <p>7/24/2024</p> <p><b>DOCUMENT NOT CONSIDERED FINAL        UNLESS ALL SIGNATURES COMPLETED</b></p>	<p>DIVISION OF HIGHWAYS        NORTH CAROLINA        DEPARTMENT OF TRANSPORTATION        WORK ZONE TRAFFIC CONTROL</p>	<p>-L- NC 150        PHASE II        STEP 1</p>
---	---	--	---

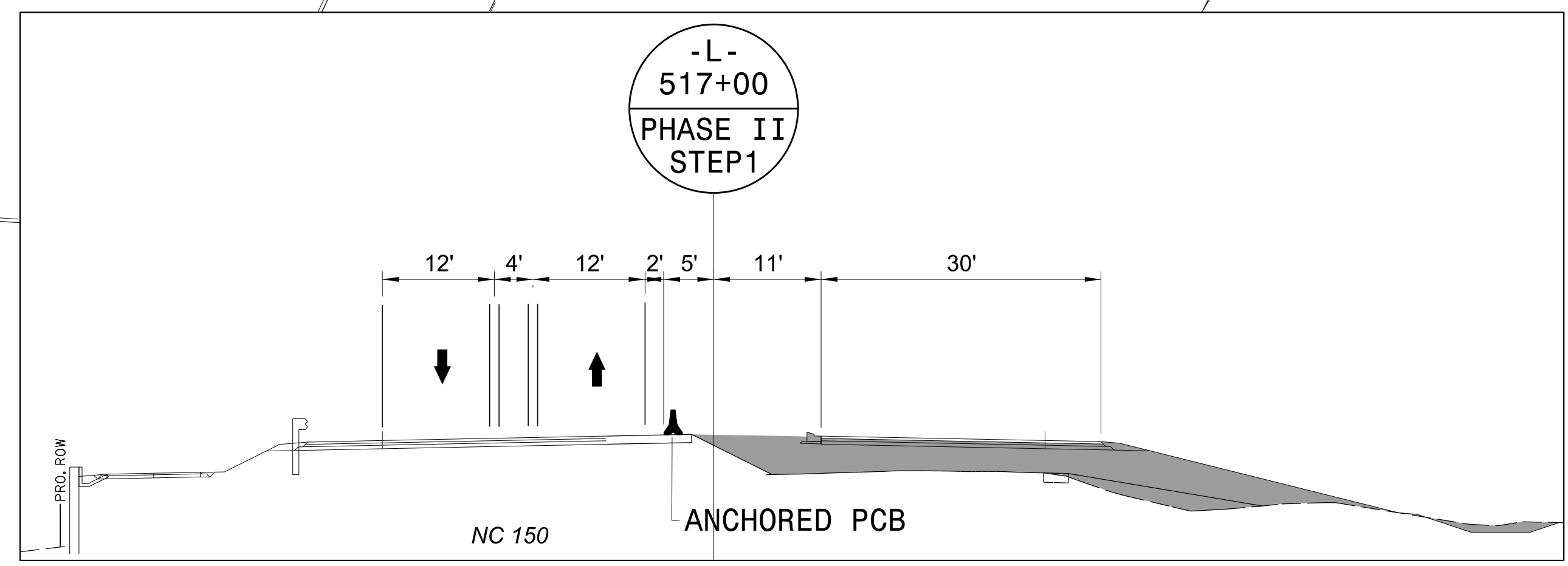
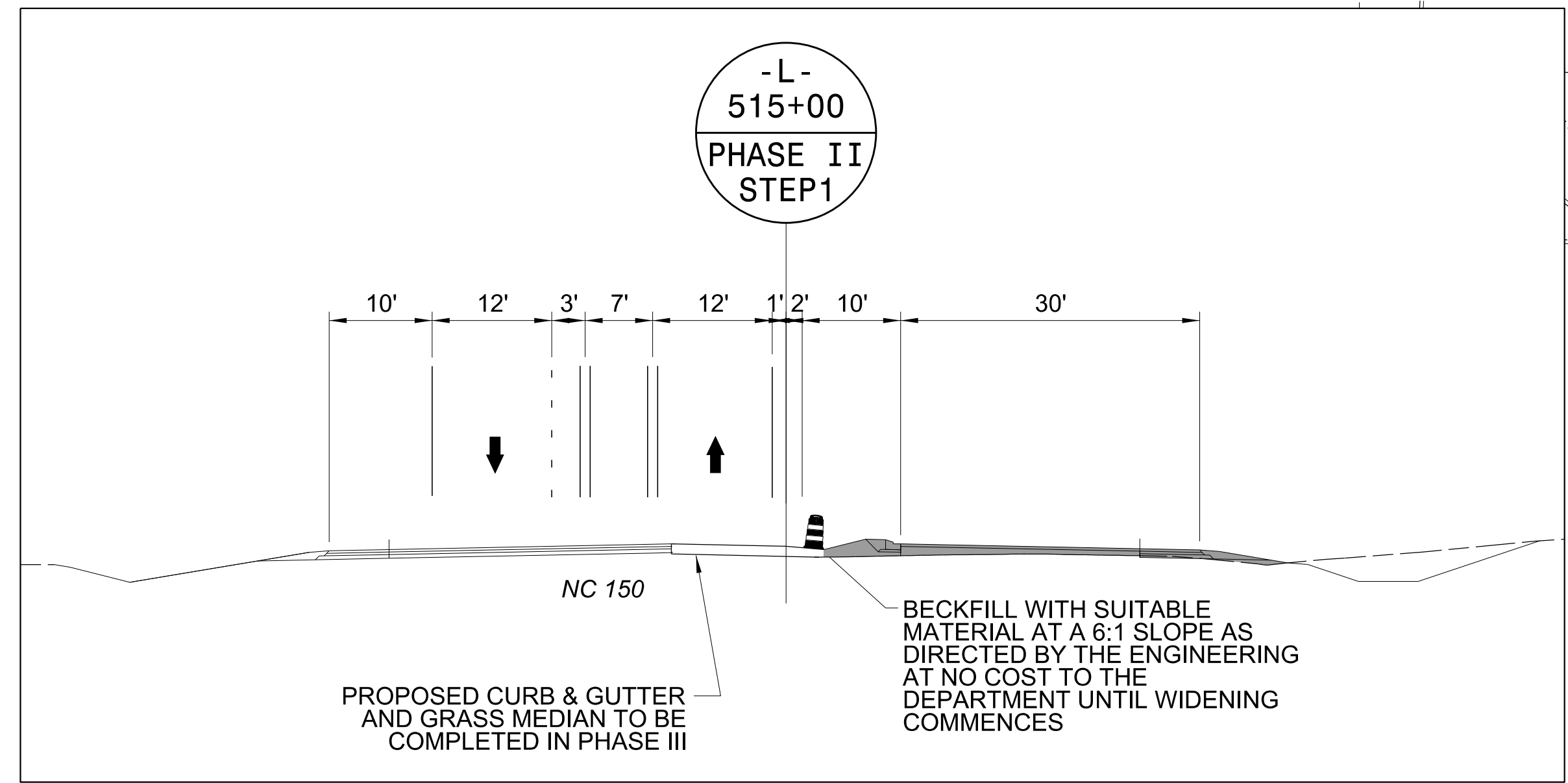
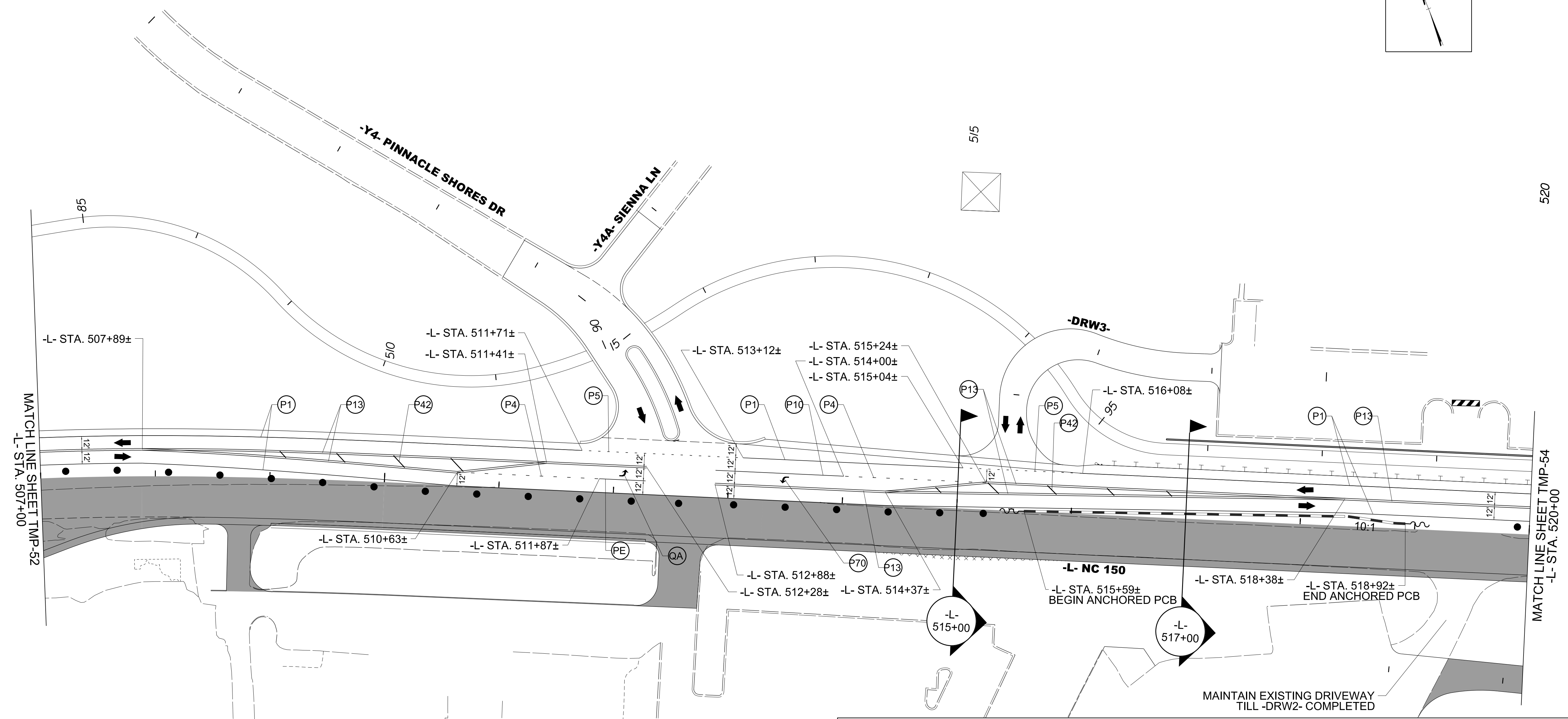
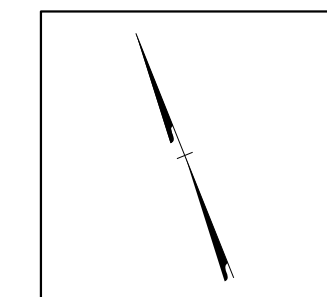

6/4/2024  
 U:\Traffic\Transportation Management\Plan\TCP\PLAN SHEETS\IR-2307B-TMP-53\_PHASE\_02\_STEP\_01.dgn  
 dorichardson

**Stantec**  
 Stantec Consulting Services Inc.  
 801 Jones Franklin Road  
 Suite 300  
 Raleigh, NC 27606  
 Tel. 919.851.6866  
 Fax. 919.851.7024  
 www.stantec.com  
 License No. F-0672

DocuSigned by  
 J.W. Woolard  
 919862  
 7/24/2024  
 DOCUMENT NOT CONSIDERED FINAL  
 UNLESS ALL SIGNATURES COMPLETED

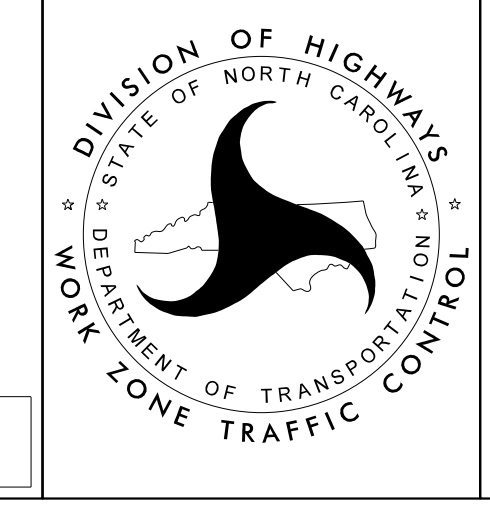

-L- NC 150  
 PHASE II  
 STEP 1

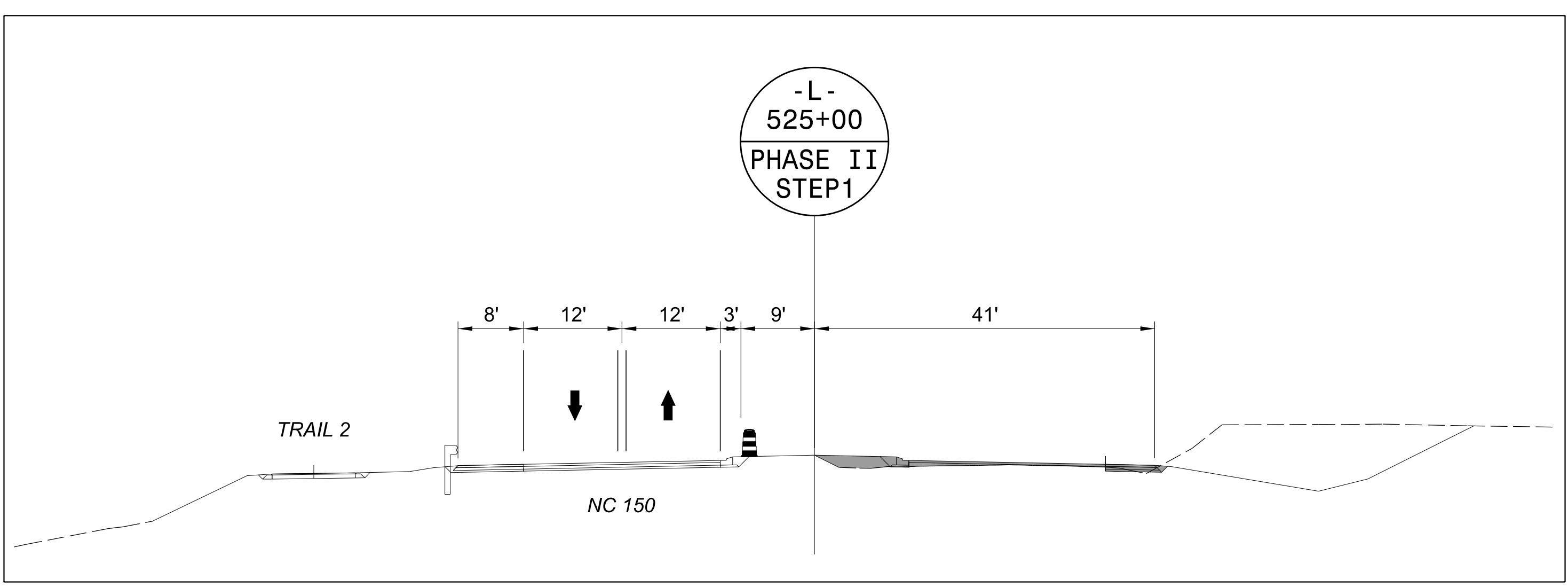
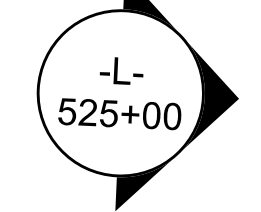
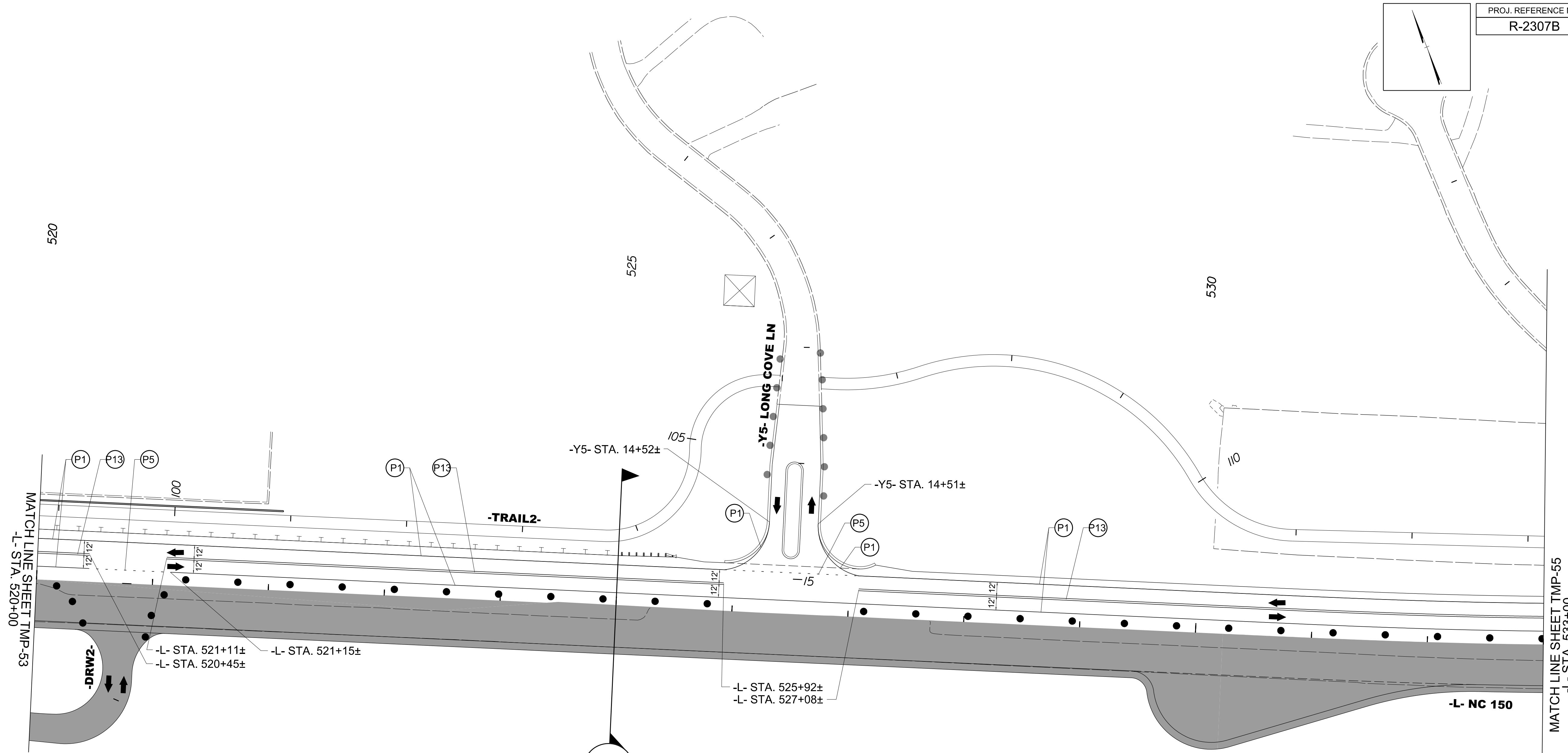
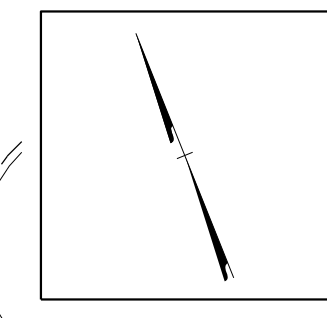

6/4/2024  
 U:\Traffic\Transportation Management Plan\TCP\PLAN SHEETS\IR-2307B-TMP-54\_PHASE\_02\_STEP\_01.dgn  
 dorichardson

  
 Stantec Consulting Services Inc.  
 801 Jones Franklin Road  
 Suite 300  
 Raleigh, NC 27606  
 Tel. 919.851.6866  
 Fax. 919.851.7024  
 www.stantec.com  
 License No. F-0672

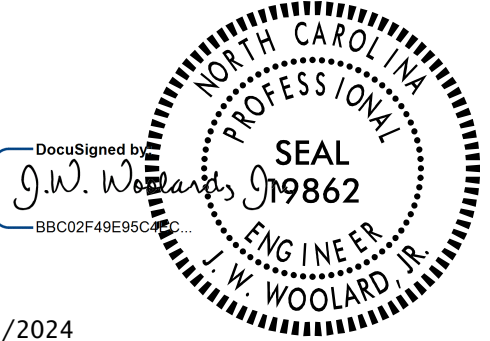
DocuSigned by  
  
 7/24/2024  
**DOCUMENT NOT CONSIDERED FINAL  
 UNLESS ALL SIGNATURES COMPLETED**

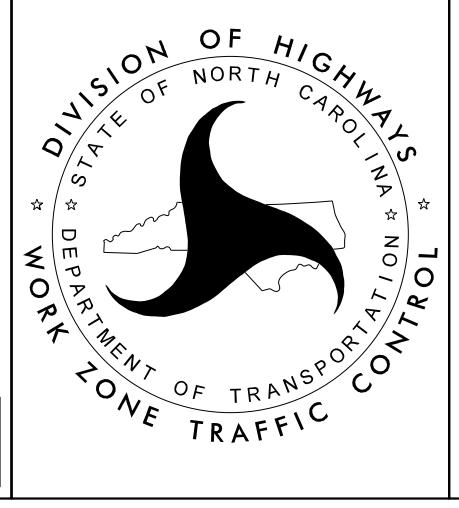

**-L- NC 150  
 PHASE II  
 STEP 1**

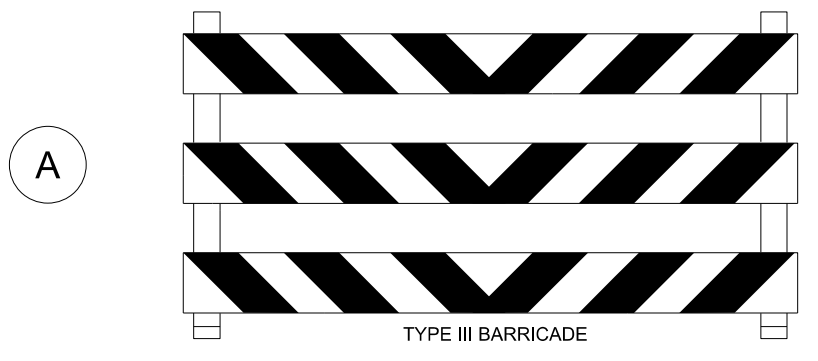
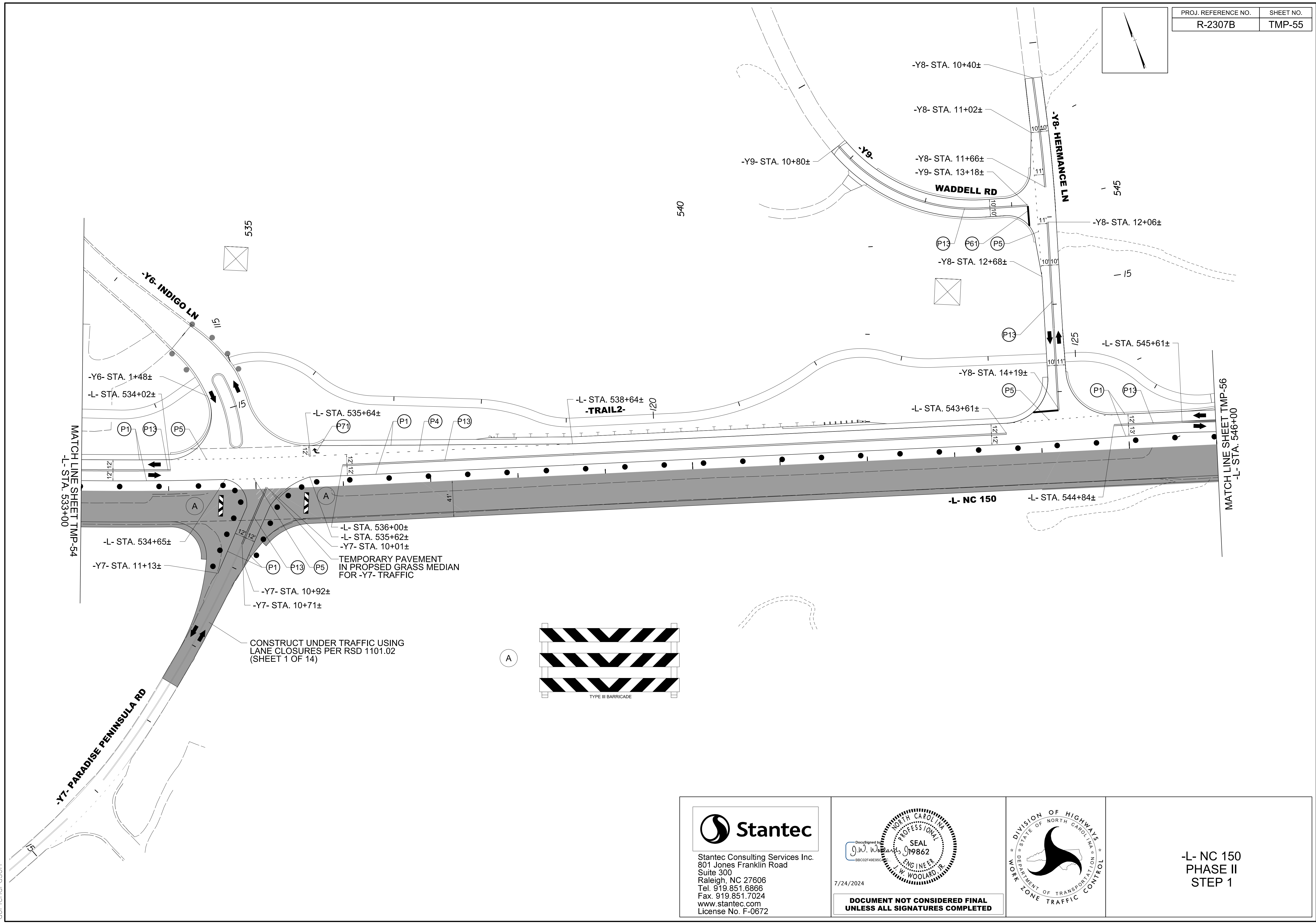

6/4/2024  
 U:\Traffic\Transportation Management\Plan\TCP\PLAN SHEETS\NR-2307B-TMP\_55\_PHASE\_02\_STEP\_01.dgn  
 dorichardson

**Stantec**  
 Stantec Consulting Services Inc.  
 801 Jones Franklin Road  
 Suite 300  
 Raleigh, NC 27606  
 Tel. 919.851.6866  
 Fax. 919.851.7024  
 www.stantec.com  
 License No. F-0672

DocuSigned by:  
 J.W. Woolard, Jr.  
 99862  
 7/24/2024

**DOCUMENT NOT CONSIDERED FINAL  
 UNLESS ALL SIGNATURES COMPLETED**

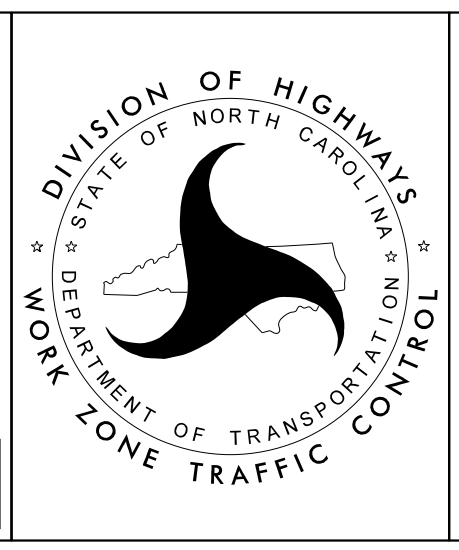

**-L- NC 150  
 PHASE II  
 STEP 1**

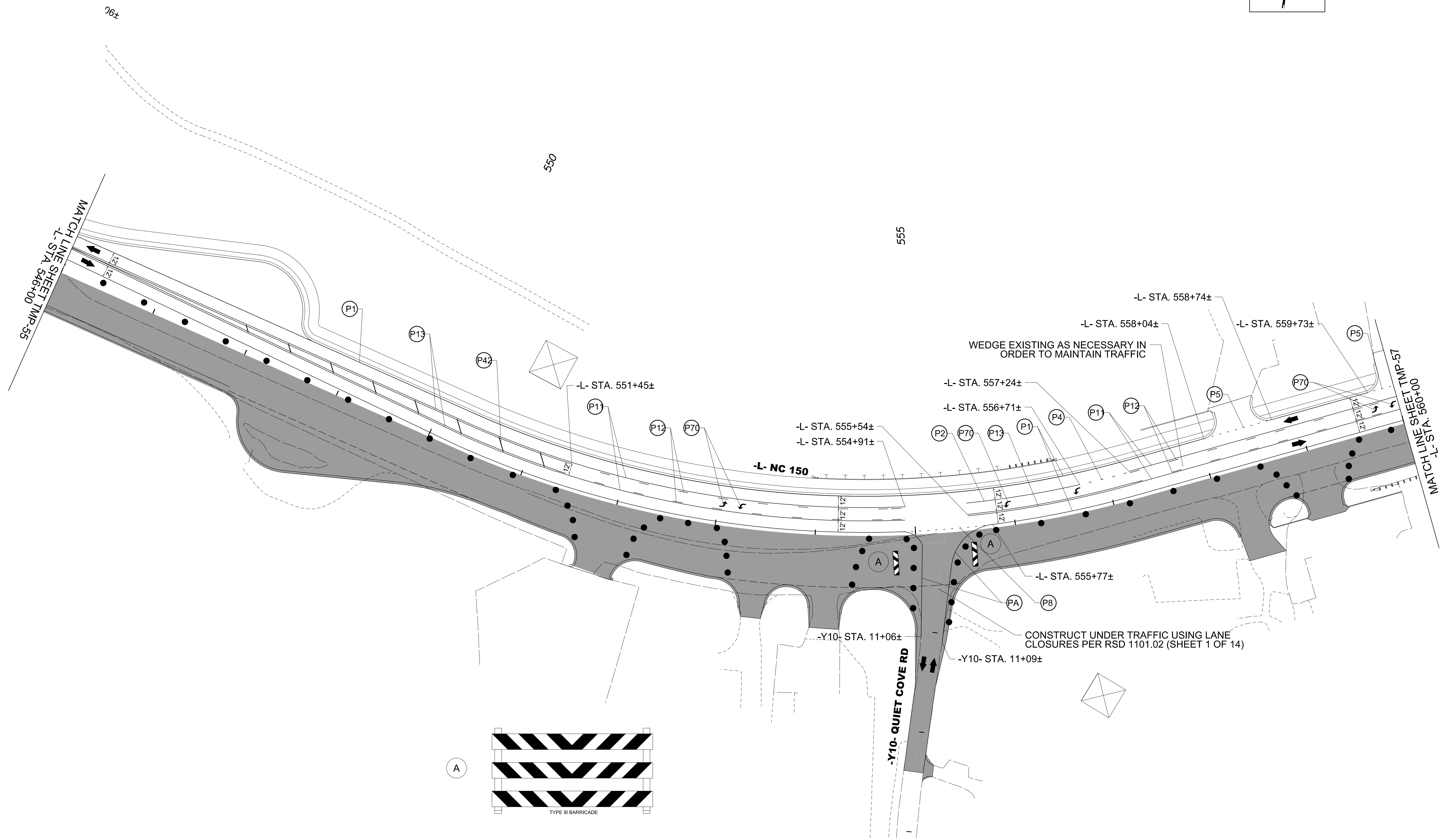
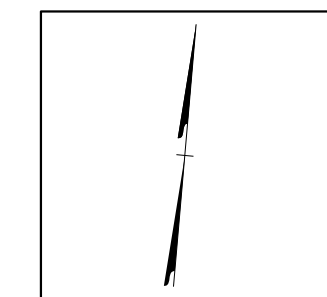

6/4/2024  
 U:\Traffic\Transportation Management\Plan\TCP\PLAN SHEETS\IR-2307B-TMP\_56\_PHASE\_02\_STEP\_01.dgn  
 dorichardson

<p>Stantec Consulting Services Inc.        801 Jones Franklin Road        Suite 300        Raleigh, NC 27606        Tel. 919.851.6866        Fax. 919.851.7024        www.stantec.com        License No. F-0672</p>	<p>DocuSigned by  <i>J.W. Woolard</i>        58C02F49E950</p> <p>7/24/2024</p> <p><b>DOCUMENT NOT CONSIDERED FINAL        UNLESS ALL SIGNATURES COMPLETED</b></p>	<p>DIVISION OF HIGHWAYS        NORTH CAROLINA        DEPARTMENT OF TRANSPORTATION        WORK ZONE TRAFFIC CONTROL</p>	<p>-L- NC 150        PHASE II        STEP 1</p>
---	---	--	---

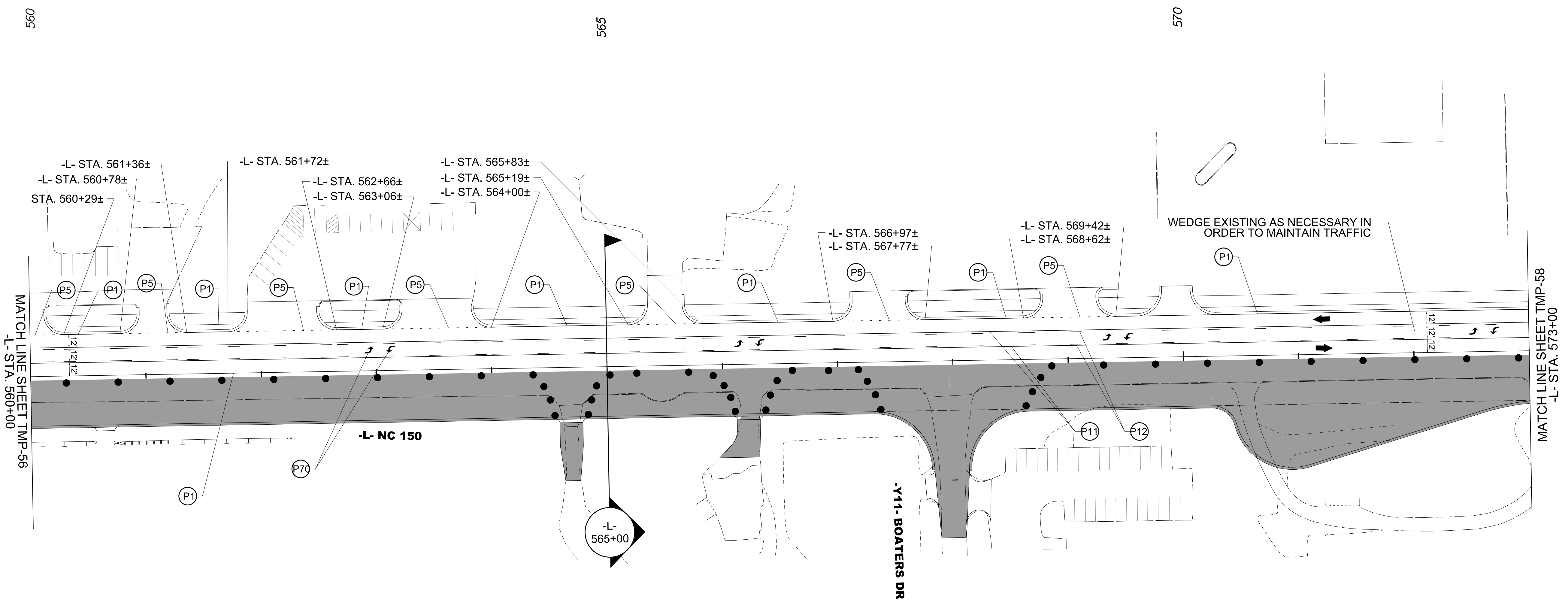
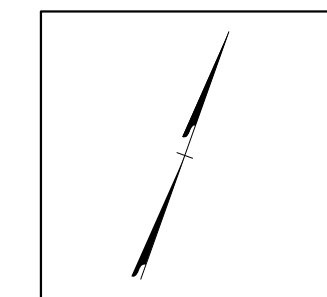

  
 Stantec Consulting Services Inc.  
 801 Jones Franklin Road  
 Suite 300  
 Raleigh, NC 27606  
 Tel. 919.851.6866  
 Fax. 919.851.7024  
 www.stantec.com  
 License No. F-0672

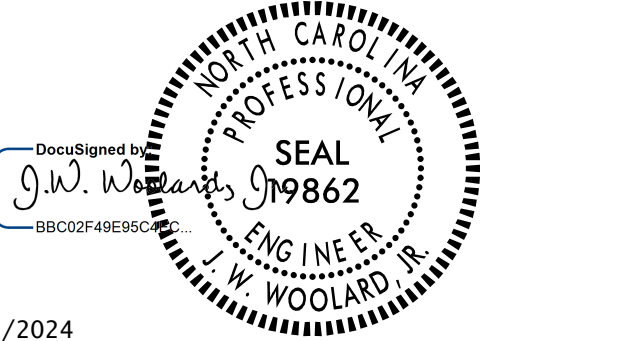
DocuSigned by  
  
 7/24/2024  
**DOCUMENT NOT CONSIDERED FINAL  
 UNLESS ALL SIGNATURES COMPLETED**

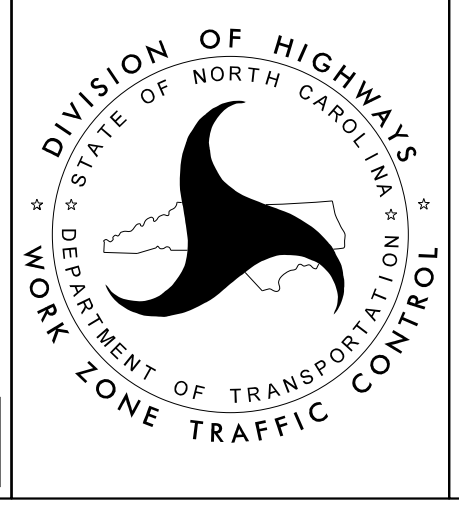

-L- NC 150  
 PHASE II  
 STEP 1

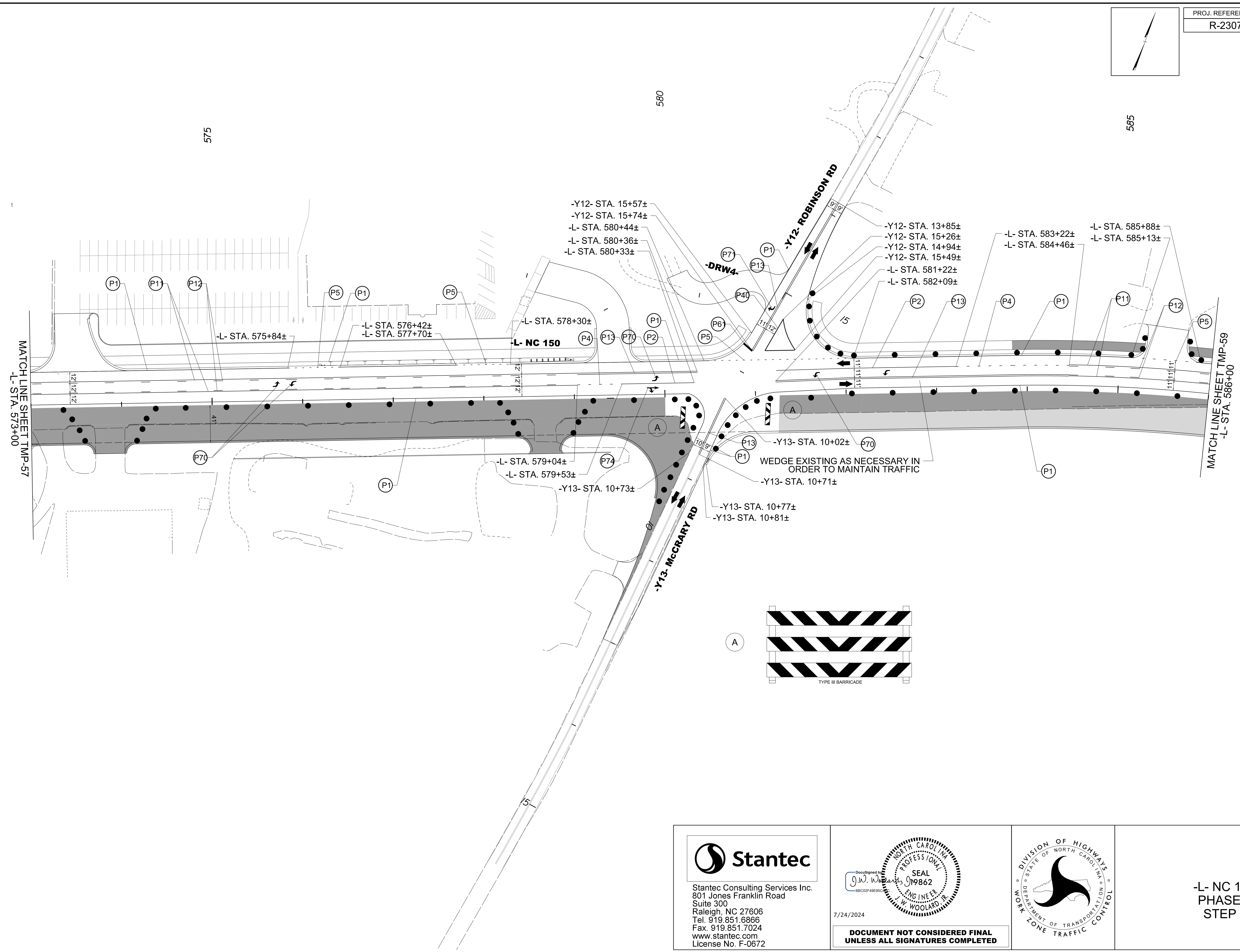
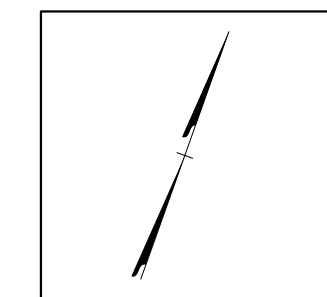

<p>Stantec Consulting Services Inc.        801 Jones Franklin Road        Suite 300        Raleigh, NC 27606        Tel. 919.851.6866        Fax. 919.851.7024        www.stantec.com        License No. F-0672</p>	<p>7/24/2024</p> <p><b>DOCUMENT NOT CONSIDERED FINAL        UNLESS ALL SIGNATURES COMPLETED</b></p>	<p>DIVISION OF HIGHWAYS        NORTH CAROLINA        DEPARTMENT OF TRANSPORTATION        WORK ZONE TRAFFIC CONTROL</p>	<p align="center"><b>-L- NC 150        PHASE II        STEP 1</b></p>
---	---	--	---

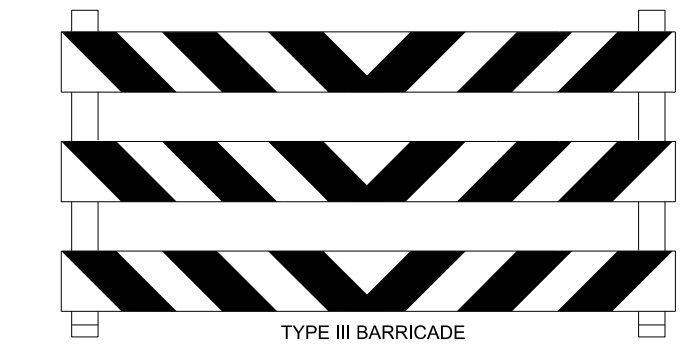
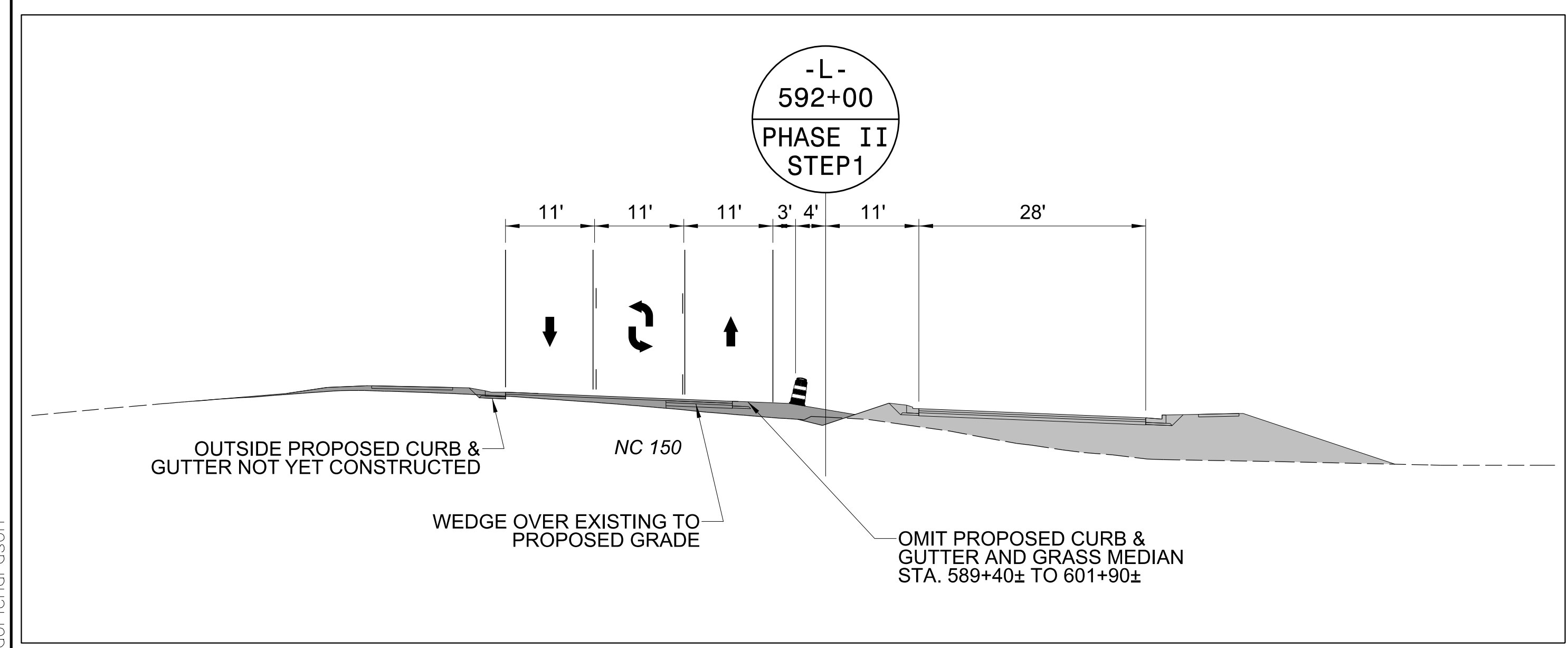
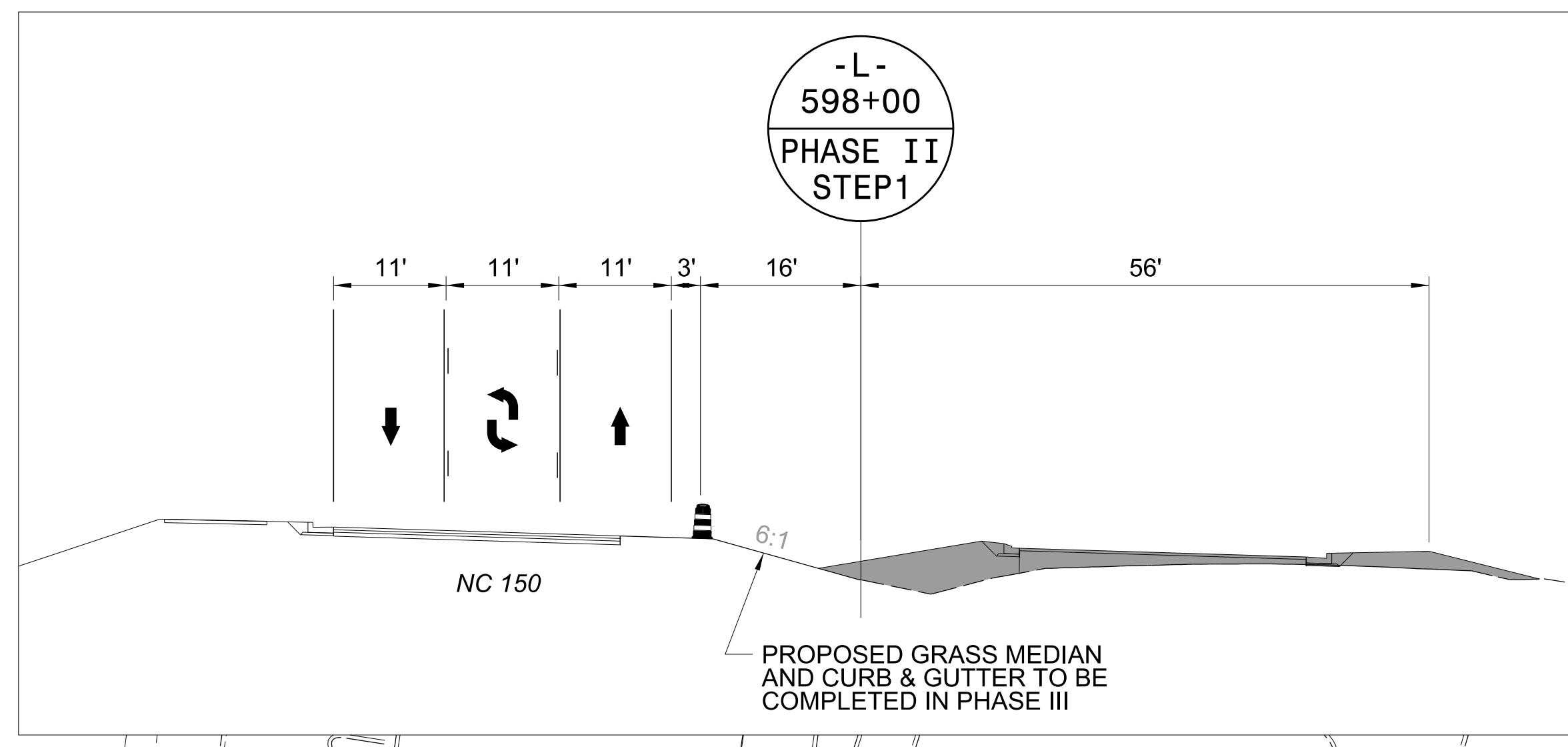
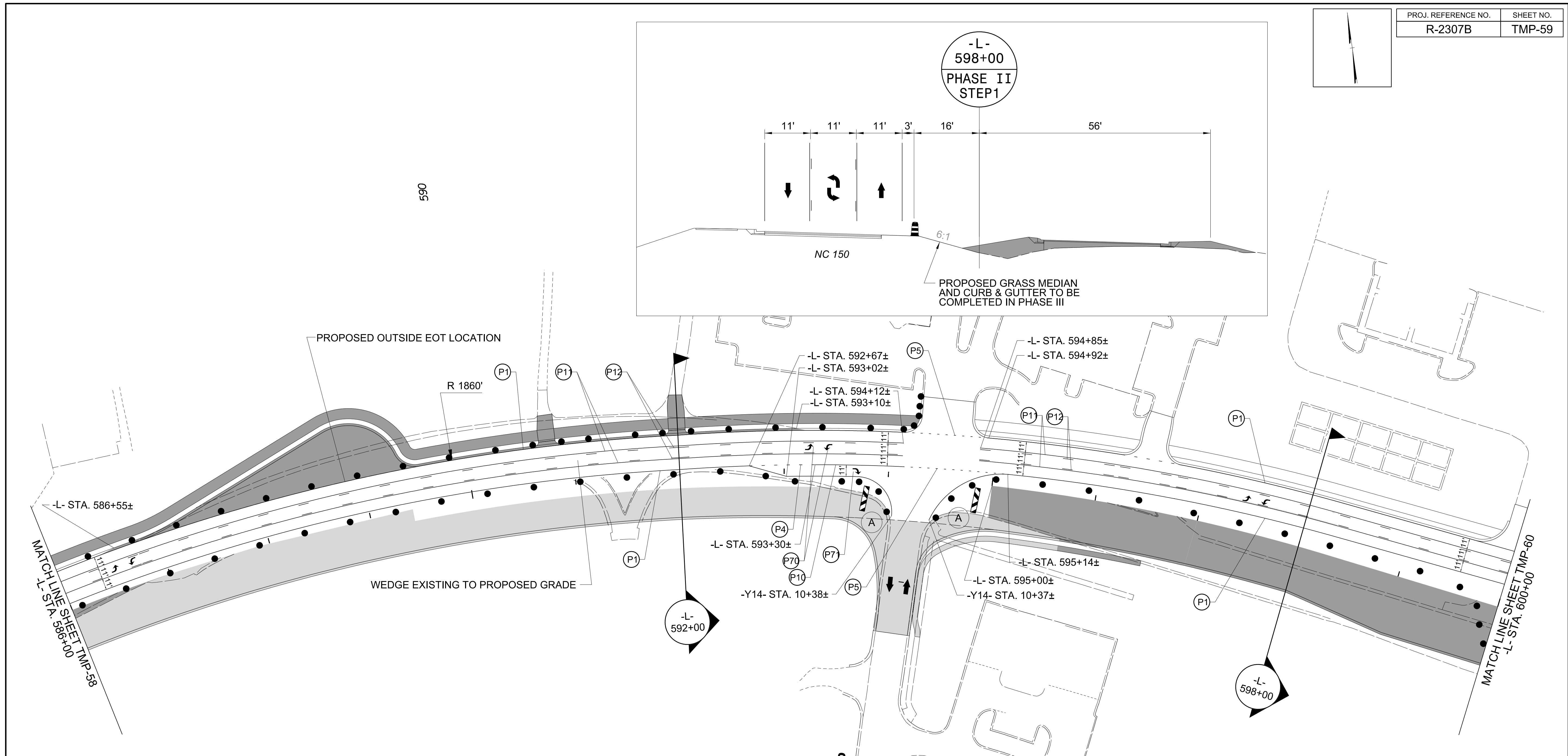

6/4/2024  
 U:\Traffic\Transportation Management\Plan\TCP\PLAN SHEETS\R-2307B-TMP\_59\_PHASE\_02\_STEP\_01.dgn  
 dorichardson

  
 Stantec Consulting Services Inc.  
 801 Jones Franklin Road  
 Suite 300  
 Raleigh, NC 27606  
 Tel. 919.851.6866  
 Fax. 919.851.7024  
 www.stantec.com  
 License No. F-0672

DocuSigned by:  
  
 7/24/2024  
**DOCUMENT NOT CONSIDERED FINAL  
 UNLESS ALL SIGNATURES COMPLETED**

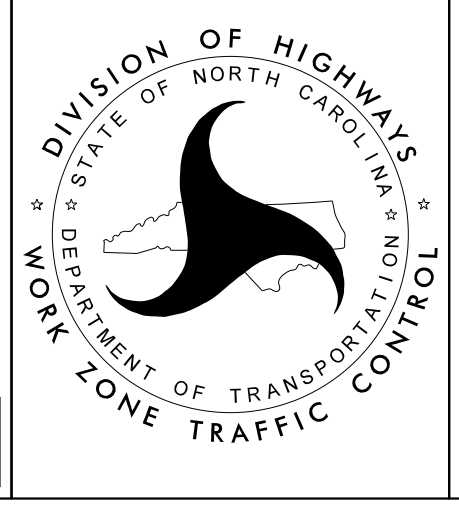

-L- NC 150  
 PHASE II  
 STEP 1



PROJ. REFERENCE NO.	SHEET NO.
R-2307B	TMP-60

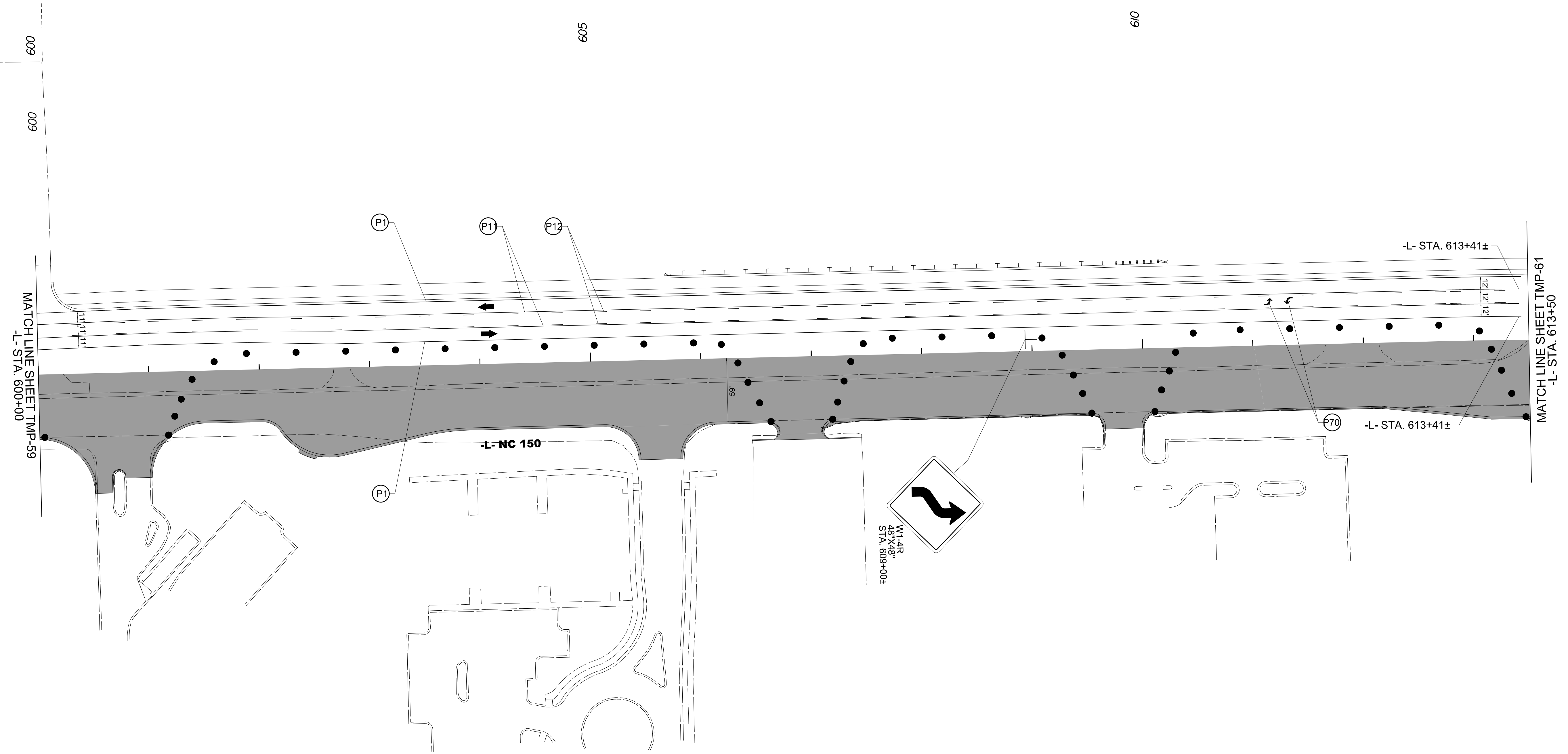
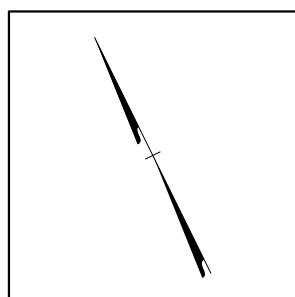

6/4/2024  
 U:\Traffic\Transportation Management Plan\TCP\PLAN SHEETS\IR-2307B-TMP\_60\_PHASE\_02\_STEP\_01.dgn  
 dorichardson

  
 Stantec Consulting Services Inc.  
 801 Jones Franklin Road  
 Suite 300  
 Raleigh, NC 27606  
 Tel. 919.851.6866  
 Fax. 919.851.7024  
 www.stantec.com  
 License No. F-0672

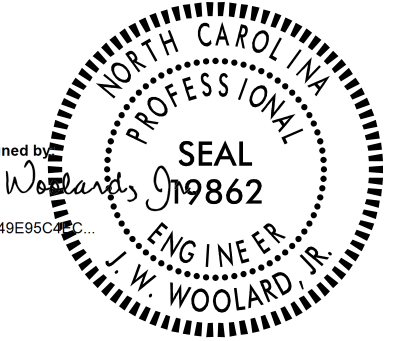
DocuSigned by:  
  
 7/24/2024  
**DOCUMENT NOT CONSIDERED FINAL  
 UNLESS ALL SIGNATURES COMPLETED**

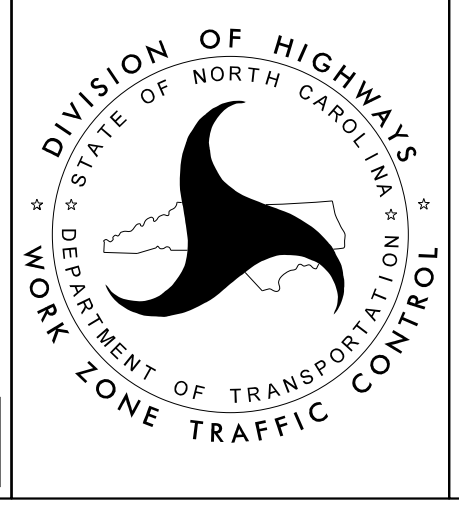

**NC-150 -L-  
 PHASE II  
 STEP 1**

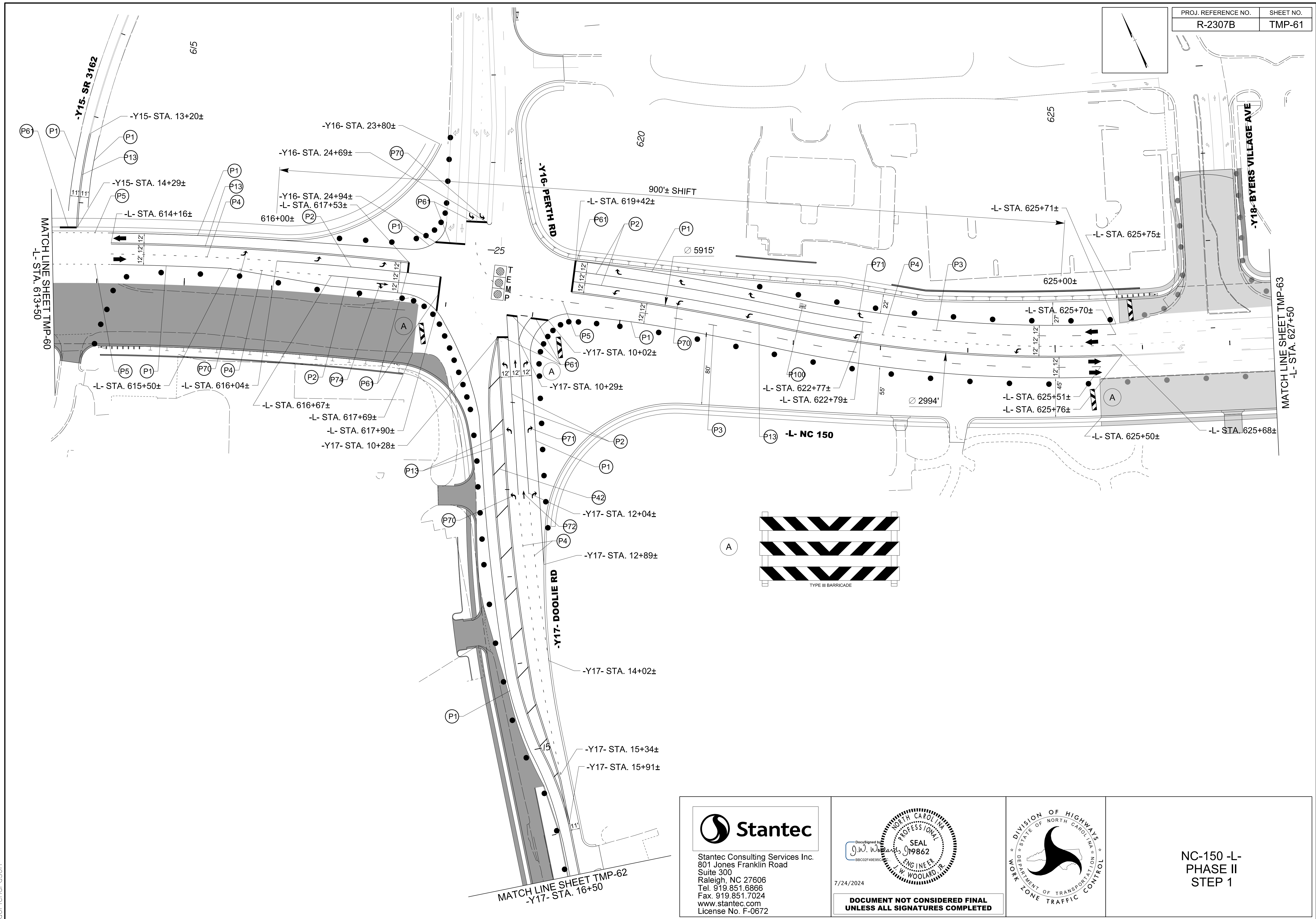

6/4/2024  
 U:\Traffic\Transportation Management\Plan\TCP\PLAN SHEETS\NR-2307B-TMP\_61-PHASE\_02-STEP\_01.dgn  
 dorichardson

**Stantec**  
 Stantec Consulting Services Inc.  
 801 Jones Franklin Road  
 Suite 300  
 Raleigh, NC 27606  
 Tel. 919.851.6866  
 Fax. 919.851.7024  
 www.stantec.com  
 License No. F-0672

DocuSigned by  
 J.W. Woolard  
 919862  
 SEAL  
 PROFESSIONAL ENGINEER  
 W. WOOLARD, R.  
 7/24/2024

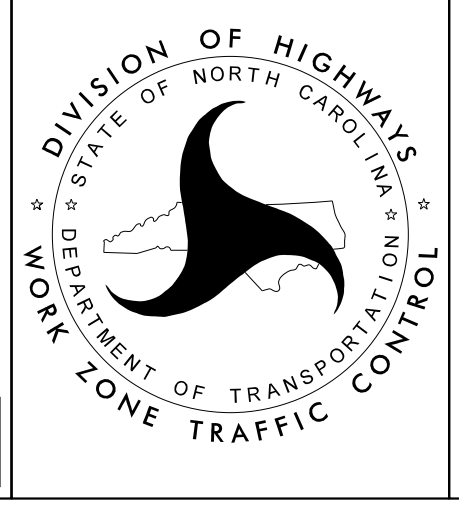

NC-150 -L-  
 PHASE II  
 STEP 1

DOCUMENT NOT CONSIDERED FINAL  
 UNLESS ALL SIGNATURES COMPLETED

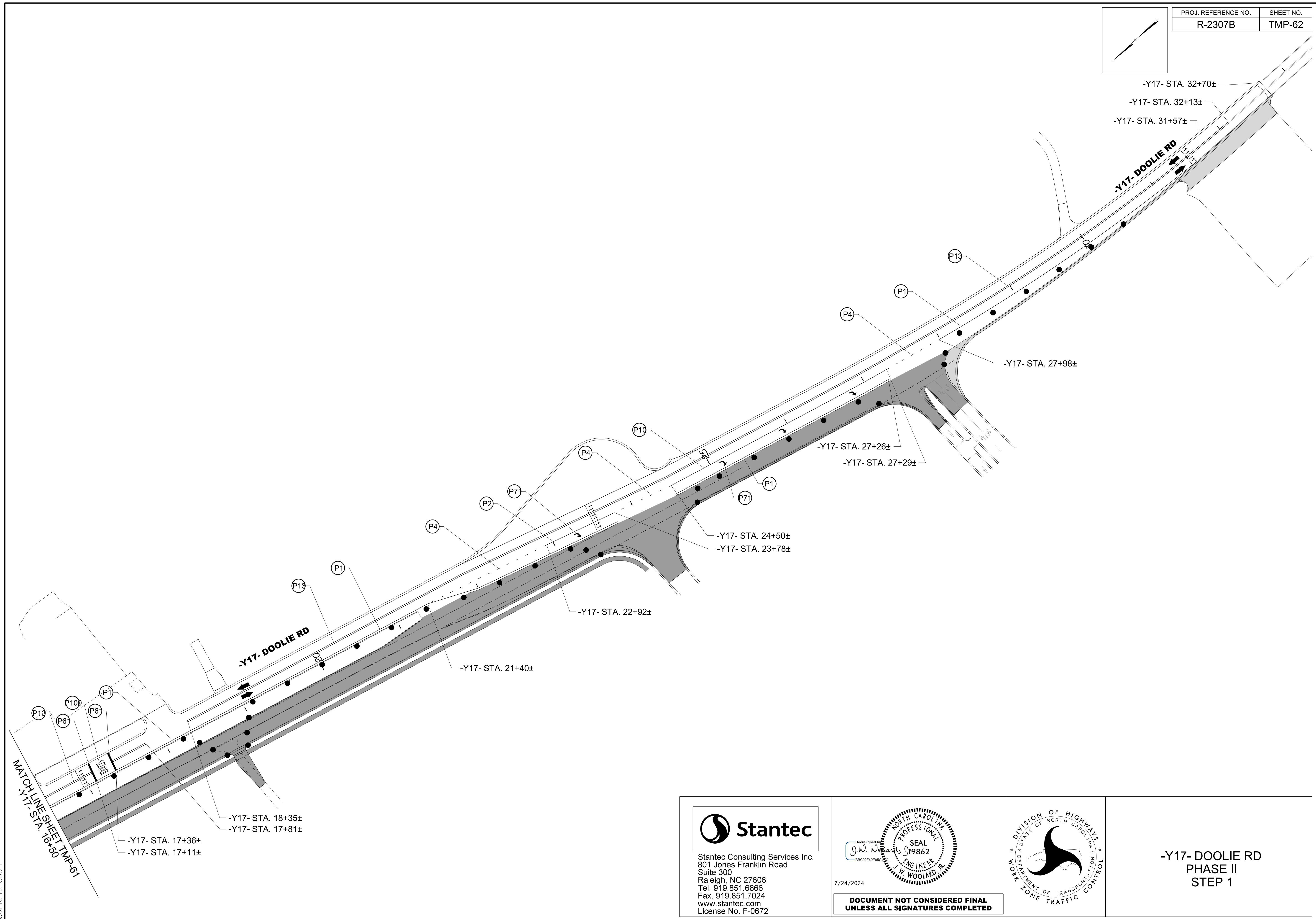
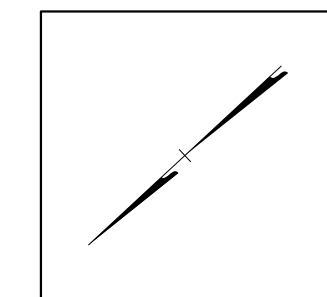

6/4/2024  
 U:\Traffic\Transportation Management\Plan\TCP\PLAN SHEETS\Y17-2307B-TMP-62-PHASE-02-STEP-01.dgn  
 dorichardson

Stantec Consulting Services Inc.  
 801 Jones Franklin Road  
 Suite 300  
 Raleigh, NC 27606  
 Tel. 919.851.6866  
 Fax. 919.851.7024  
 www.stantec.com  
 License No. F-0672

DocuSigned by  
*J.W. Woolard*  
 5BC02F49E950

7/24/2024

**DOCUMENT NOT CONSIDERED FINAL  
UNLESS ALL SIGNATURES COMPLETED**

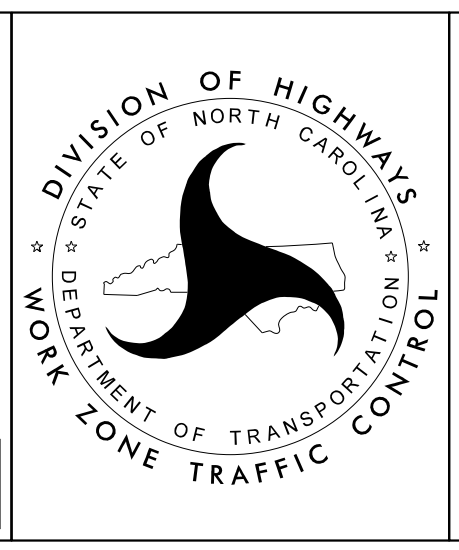

**-Y17- DOOLIE RD  
 PHASE II  
 STEP 1**

PROJ. REFERENCE NO.	SHEET NO.
R-2307B	TMP-63

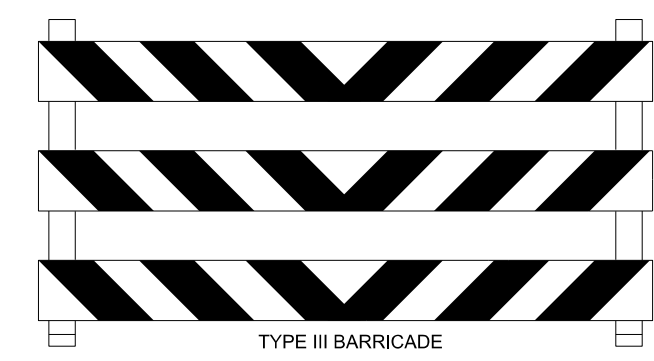
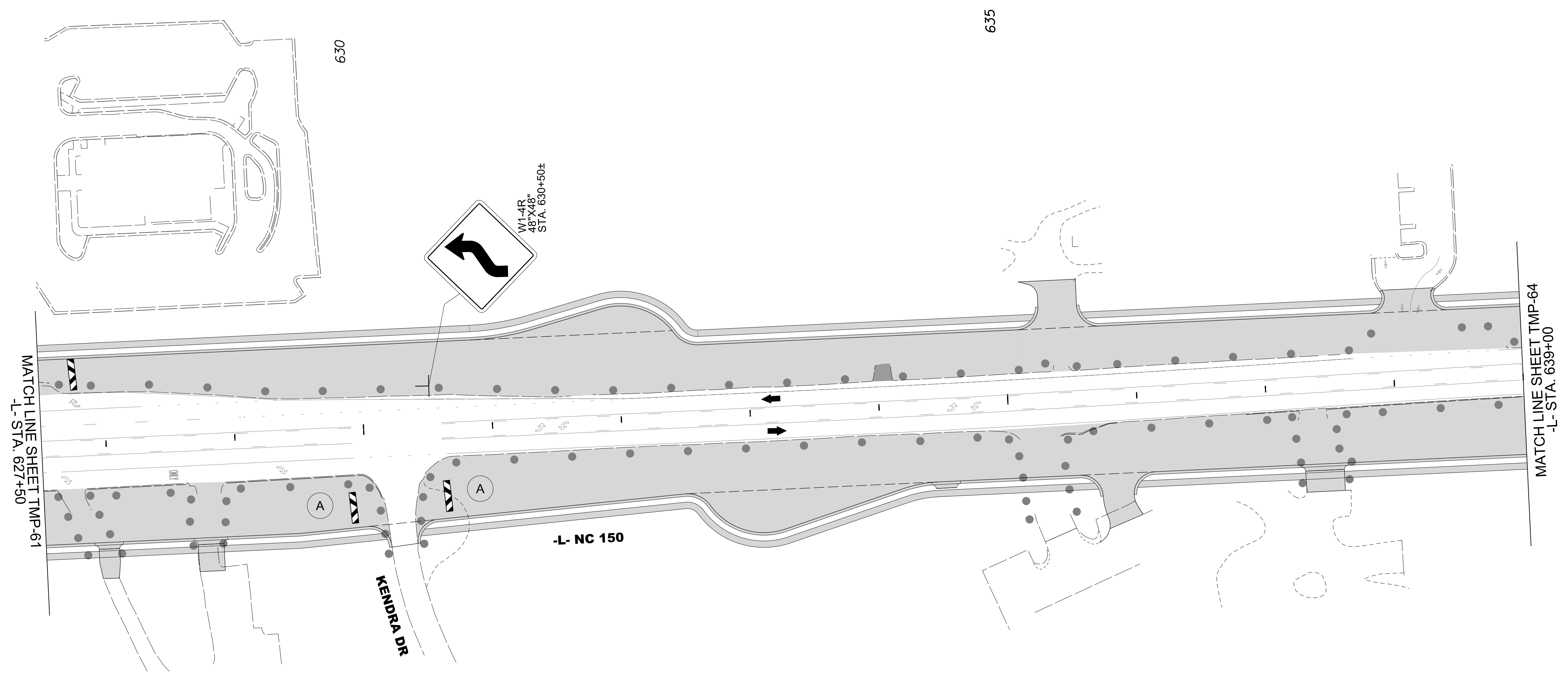
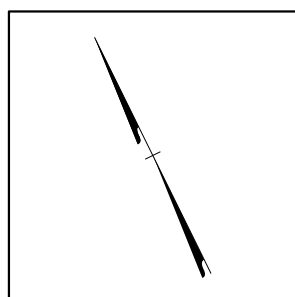

6/4/2024  
 U:\Traffic\Transportation Management\Plan\TCP\PLAN SHEETS\IR-2307B-TMP\_63\_PHASE\_02\_STEP\_01.dgn  
 dorichardson

Stantec Consulting Services Inc.  
 801 Jones Franklin Road  
 Suite 300  
 Raleigh, NC 27606  
 Tel. 919.851.6866  
 Fax. 919.851.7024  
 www.stantec.com  
 License No. F-0672

DocuSigned by  
*J.W. Woolard*  
 8BC02F49E950

7/24/2024

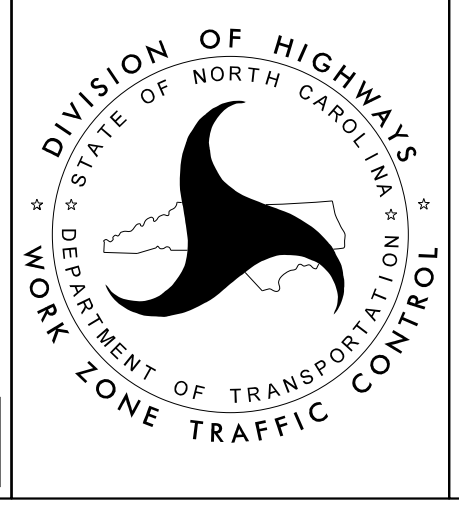

NC-150 -L-  
 PHASE II  
 STEP 1

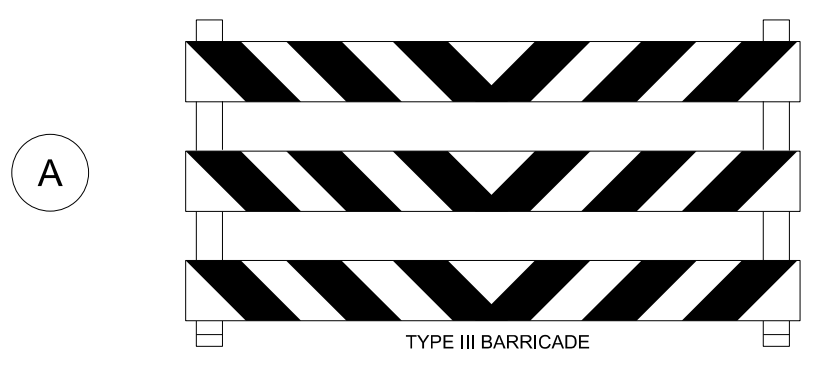
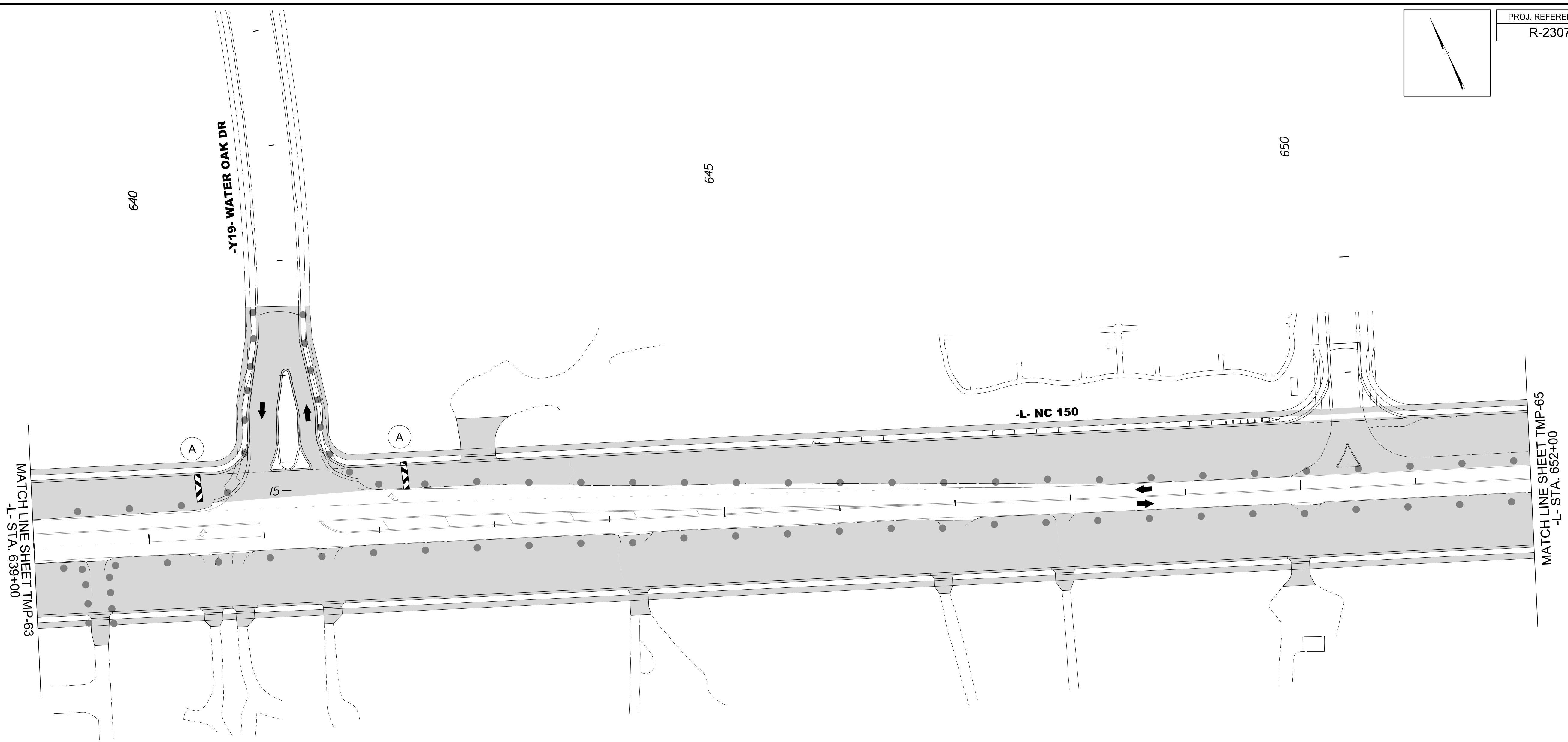
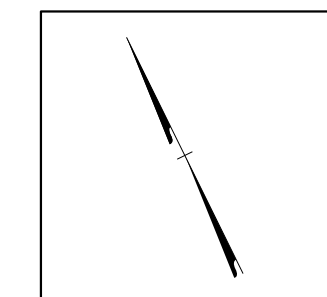

6/4/2024  
 U:\Traffic\Transportation Management\Plan\TCP\PLAN SHEETS\IR-2307B-TMP-64\_PHASE-02\_STEP\_01.dgn  
 dorichardson

Stantec Consulting Services Inc.  
 801 Jones Franklin Road  
 Suite 300  
 Raleigh, NC 27606  
 Tel. 919.851.6866  
 Fax. 919.851.7024  
 www.stantec.com  
 License No. F-0672

DocuSigned by  
 J.W. Williams  
 8BC02F49E950

7/24/2024

**DOCUMENT NOT CONSIDERED FINAL  
 UNLESS ALL SIGNATURES COMPLETED**

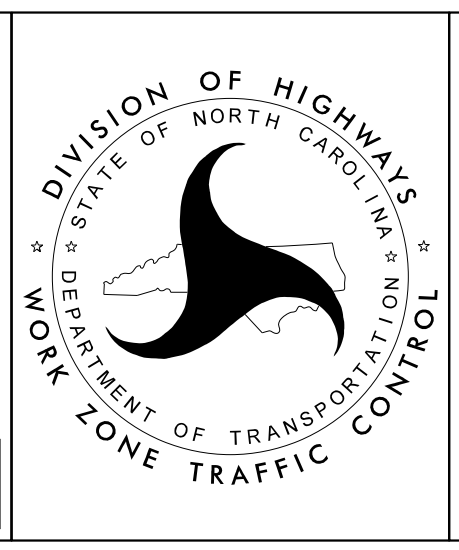

**-L- NC 150  
 PHASE II  
 STEP 1**

PROJ. REFERENCE NO.	SHEET NO.
R-2307B	TMP-65

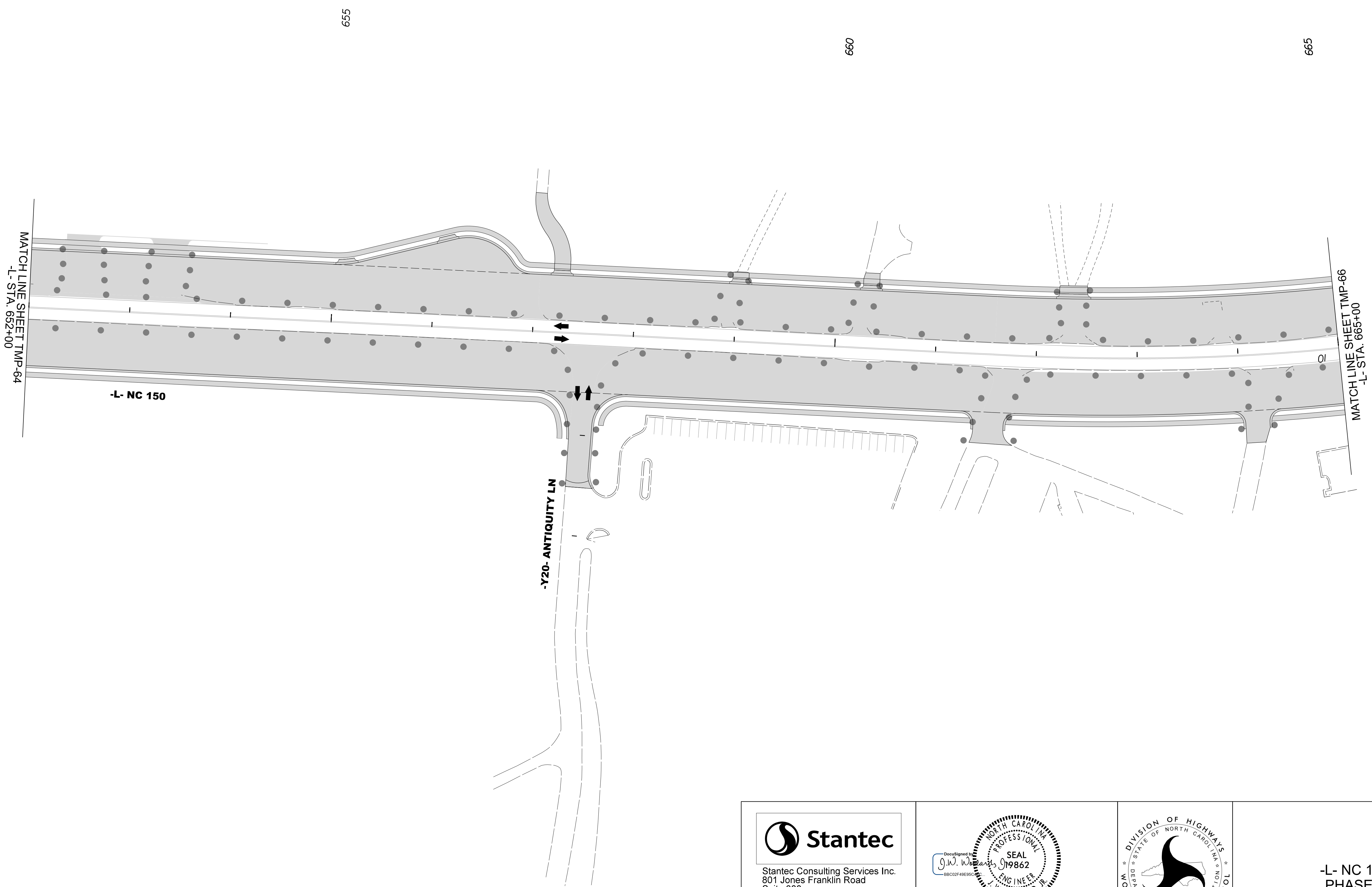
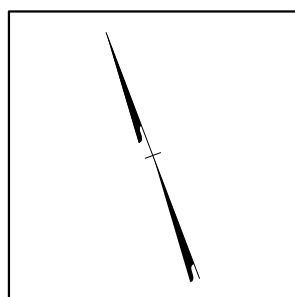

6/4/2024  
 U:\Traffic\Transportation Management\Plan\TCP\PLAN SHEETS\IR-2307B-TMP\_65\_PHASE\_02\_STEP\_01.dgn  
 dorichardson

  
 Stantec Consulting Services Inc.  
 801 Jones Franklin Road  
 Suite 300  
 Raleigh, NC 27606  
 Tel. 919.851.6866  
 Fax. 919.851.7024  
 www.stantec.com  
 License No. F-0672

DocuSigned by  
  
 7/24/2024  
**DOCUMENT NOT CONSIDERED FINAL  
 UNLESS ALL SIGNATURES COMPLETED**

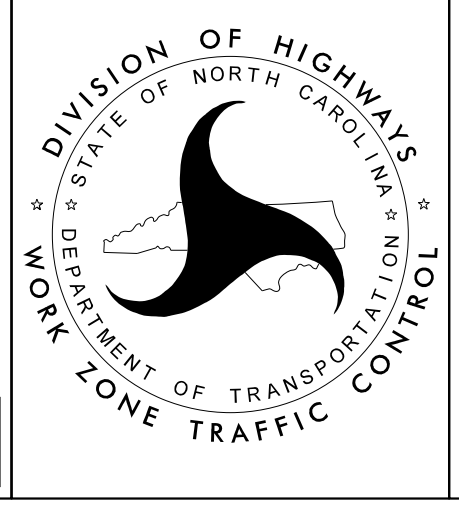

**-L- NC 150  
 PHASE II  
 STEP 1**

PROJ. REFERENCE NO.	SHEET NO.
R-2307B	TMP-66

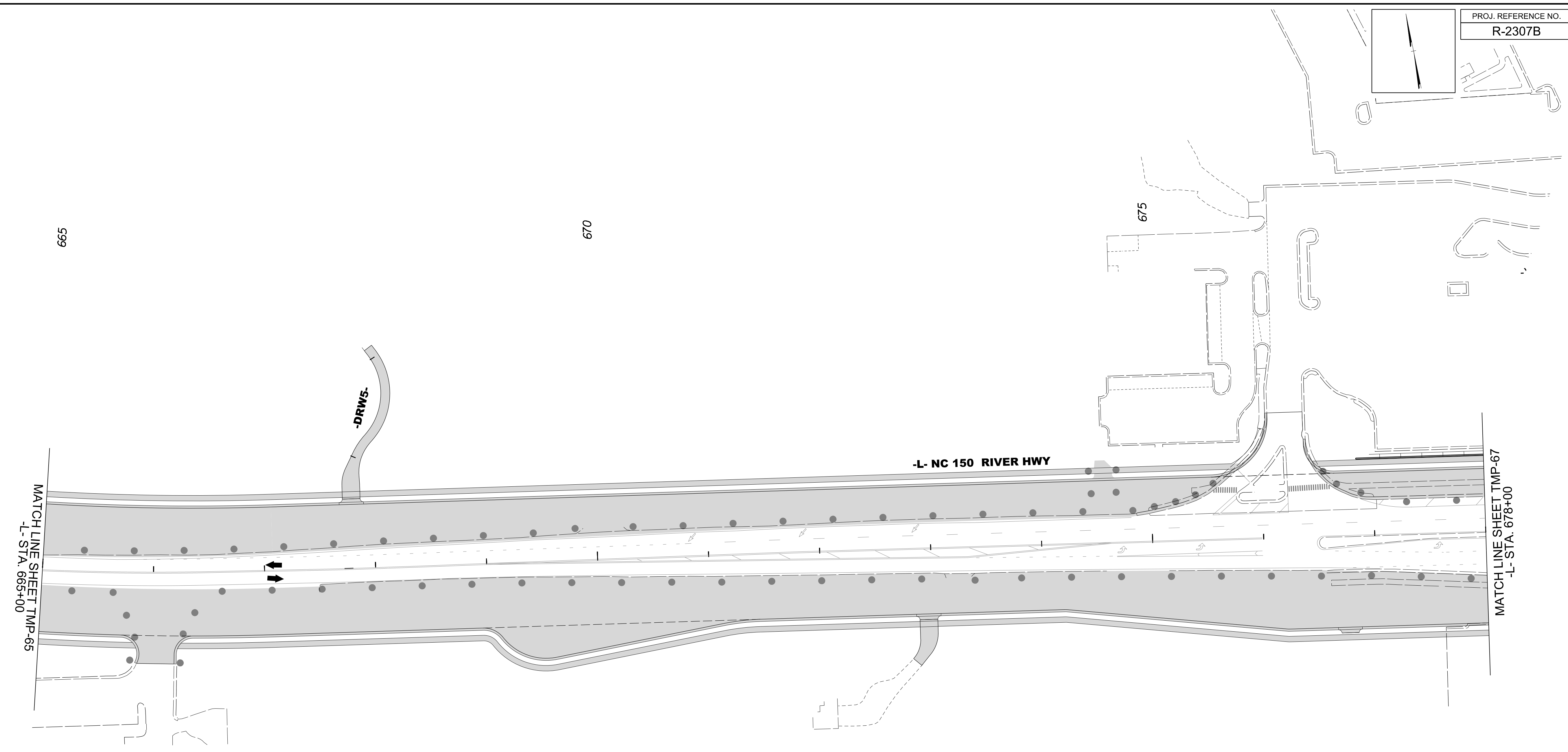

6/4/2024  
 U:\Traffic\Transportation Management\Plan\TCP\PLAN SHEETS\IR-2307B-TMP-66\_PHASE-02\_STEP\_01.dgn  
 dorichardson

**Stantec**  
 Stantec Consulting Services Inc.  
 801 Jones Franklin Road  
 Suite 300  
 Raleigh, NC 27606  
 Tel. 919.851.6866  
 Fax. 919.851.7024  
 www.stantec.com  
 License No. F-0672

DocuSigned by  
 J.W. Woolard  
 7/24/2024

SEAL  
 19862  
 W. WOOLARD, R.  
 PROFESSIONAL ENGINEER  
 NORTH CAROLINA

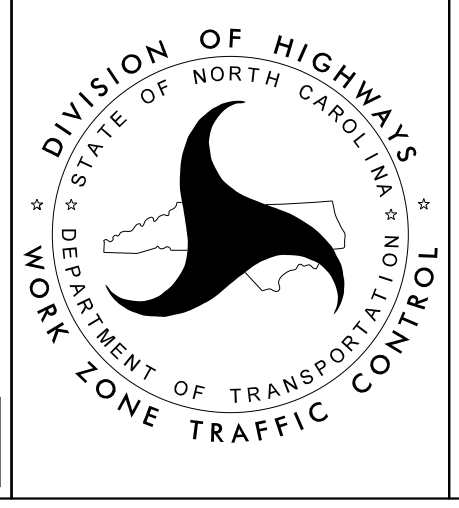

-L- NC 150  
 PHASE II  
 STEP 1

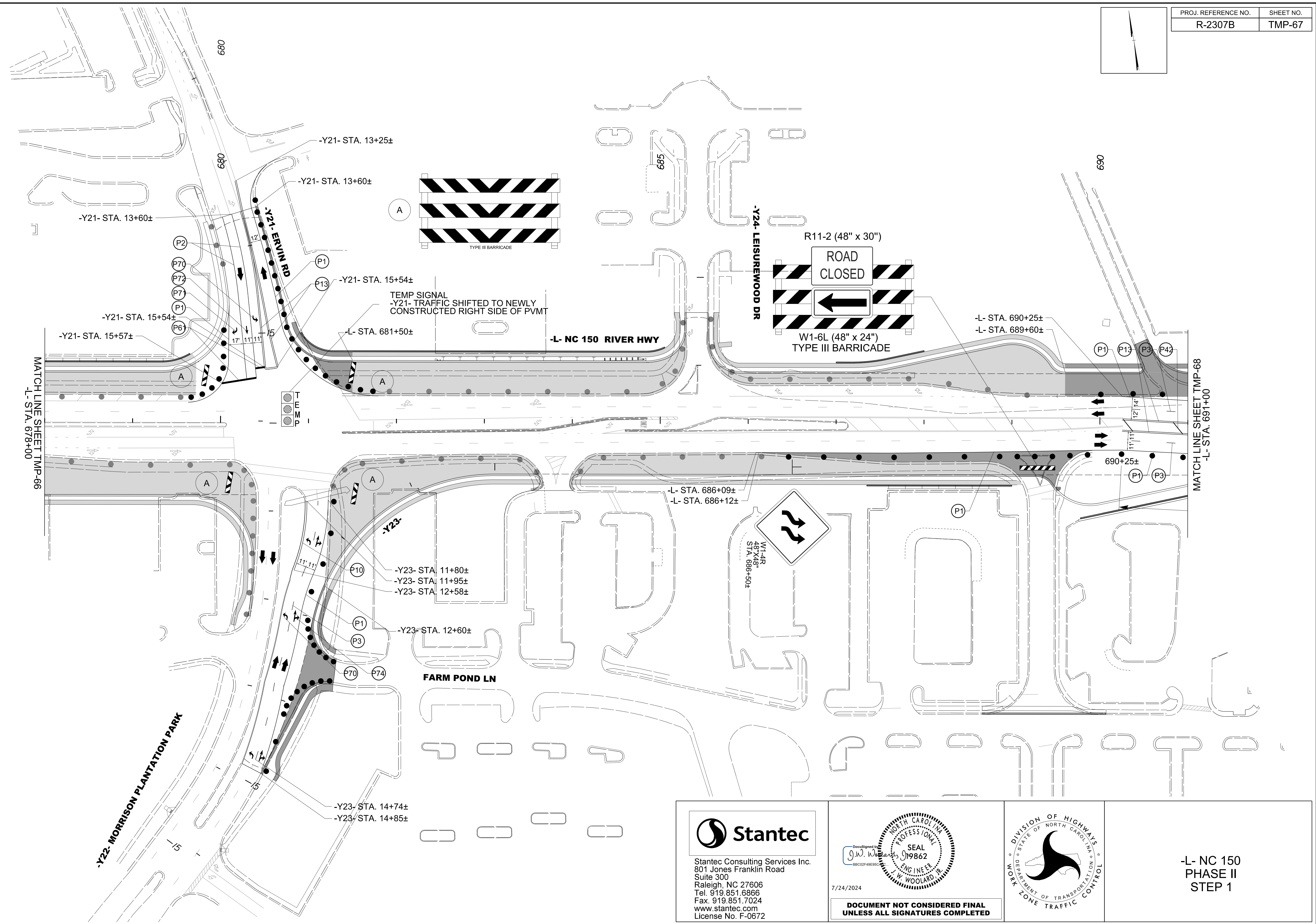
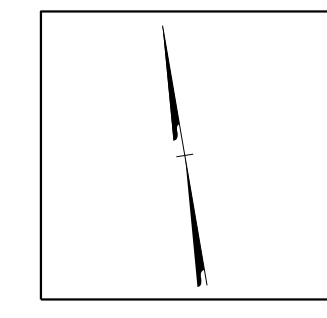

6/4/2024  
 U:\Traffic\Transportation Management Plan\TCP\PLAN SHEETS\VR-2307B-TMP\_67\_PHASE\_02\_STEP\_01.dgn  
 dorichardson

<p>Stantec Consulting Services Inc.        801 Jones Franklin Road        Suite 300        Raleigh, NC 27606        Tel. 919.851.6866        Fax. 919.851.7024        www.stantec.com        License No. F-0672</p>	<p>DocuSigned by  <i>J.W. Woolard</i>        58C02F4E93D</p> <p>7/24/2024</p> <p><b>DOCUMENT NOT CONSIDERED FINAL        UNLESS ALL SIGNATURES COMPLETED</b></p>	<p>DIVISION OF HIGHWAYS        STATE OF NORTH CAROLINA        DEPARTMENT OF TRANSPORTATION        WORK ZONE TRAFFIC CONTROL</p>	<p><b>L- NC 150        PHASE II        STEP 1</b></p>
---	--	---	---



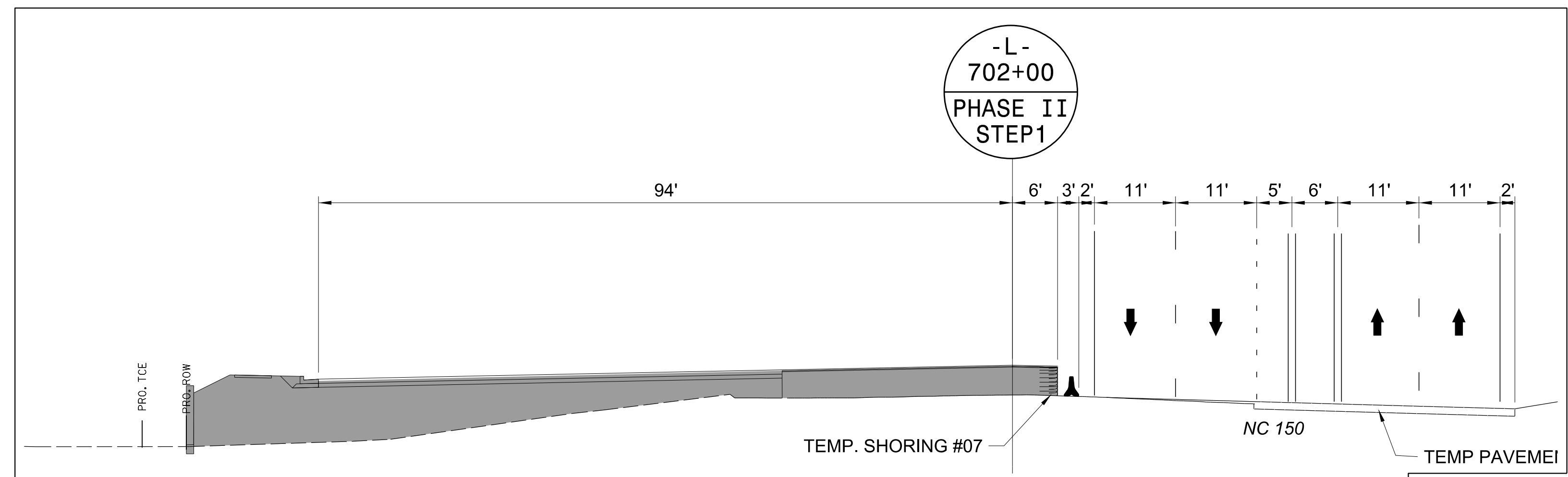
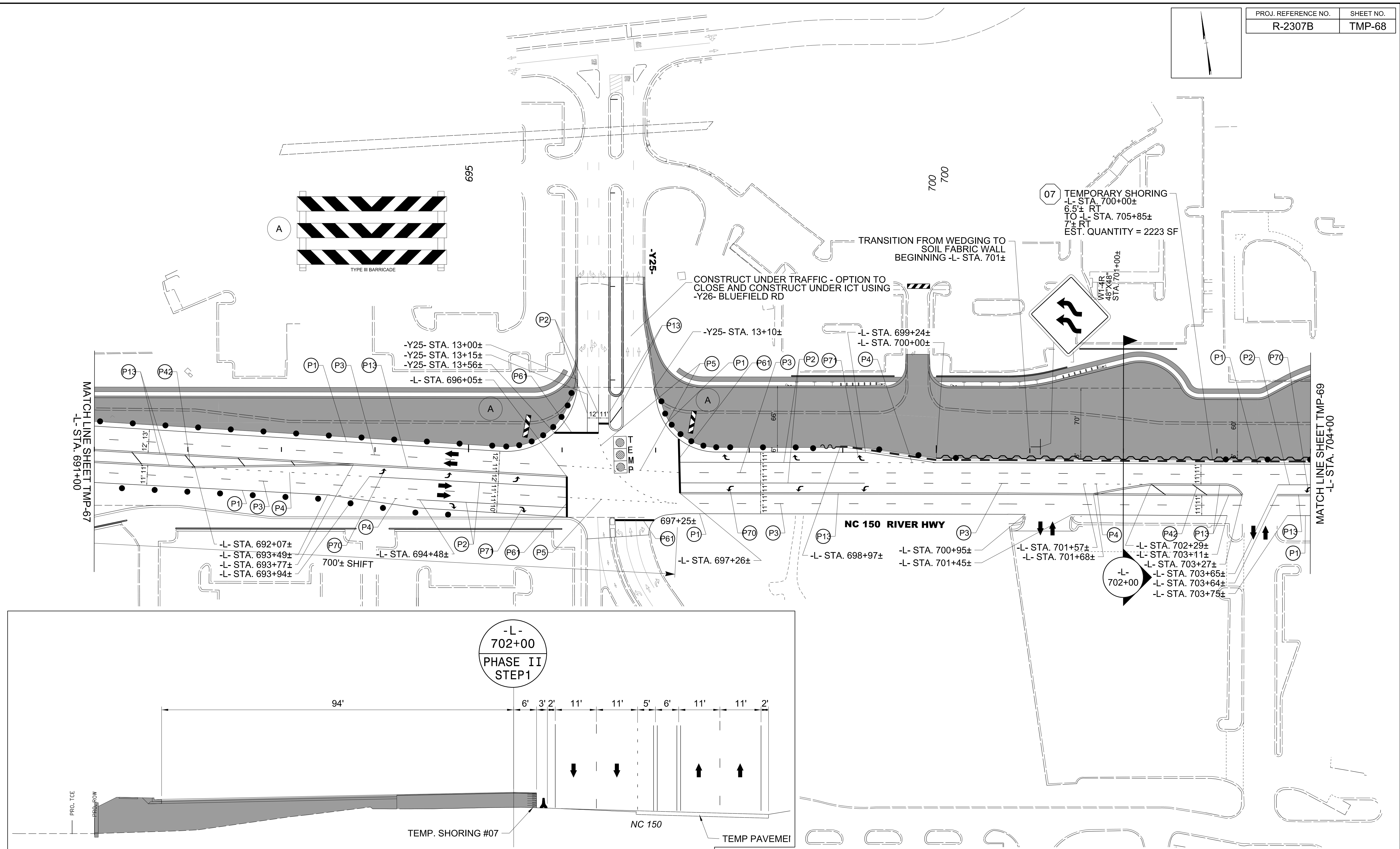

SEE SHEET TMP-2A AND TMP-2B FOR TEMPORARY SHORING DATA

**Stantec**  
 Stantec Consulting Services Inc.  
 801 Jones Franklin Road  
 Suite 300  
 Raleigh, NC 27606  
 Tel. 919.851.6866  
 Fax. 919.851.7024  
 www.stantec.com  
 License No. F-0672

DocuSigned by  
*J.W. Woolard*  
 8BC02F49E930  
 7/24/2024

PROFESSOR  
 SEAL  
 19862  
 ENGINEER  
 J. W. WOOLARD, R.

DIVISION OF HIGHWAYS  
 STATE OF NORTH CAROLINA  
 DEPARTMENT OF TRANSPORTATION  
 WORK ZONE TRAFFIC CONTROL

-L- NC 150  
 PHASE II  
 STEP 1

6/4/2024  
 U:\Traffic\Transportation Management\Plan\TCP\PLAN SHEETS\IR-2307B-TMP\_68\_PHASE\_02\_STEP\_01.dgn  
 dorichardson

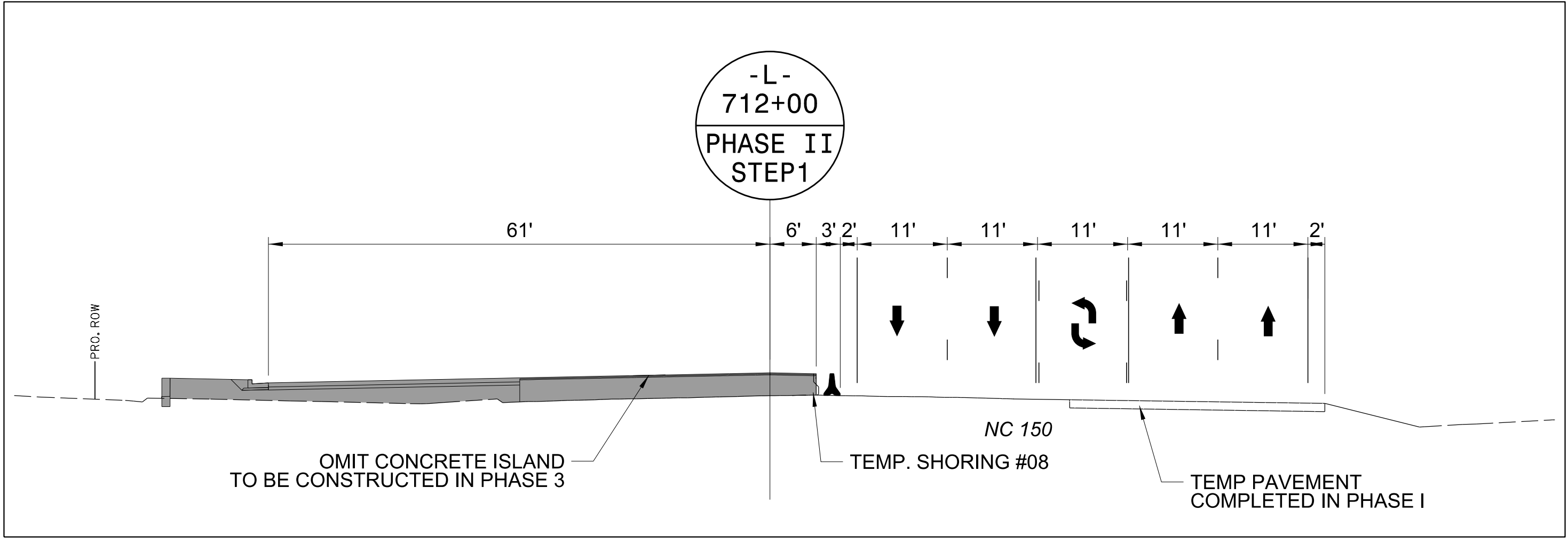
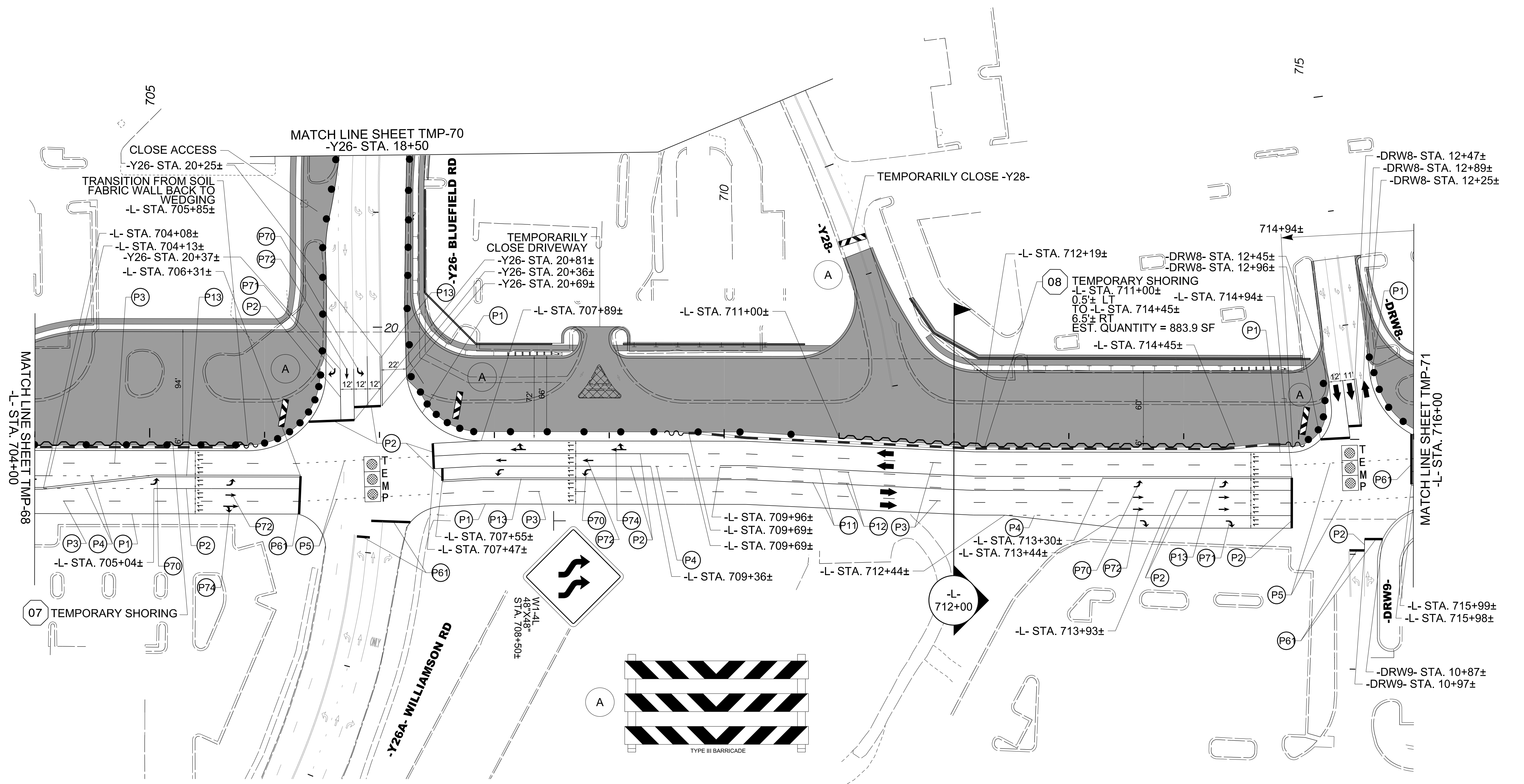
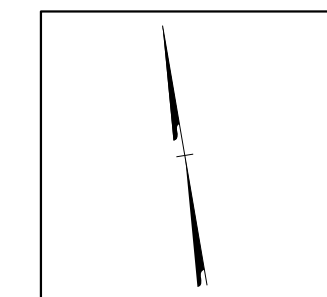

SEE SHEET TMP-2A AND TMP-2B FOR TEMPORARY SHORING DATA

6/4/2024 L:\Traffic\Transportation Management Plan\TCP\PLAN SHEETS\IR-2307B-TMP\_69\_PHASE\_02\_STEP\_01.dgn dorichardson

**Stantec**  
 Stantec Consulting Services Inc.  
 801 Jones Franklin Road  
 Suite 300  
 Raleigh, NC 27606  
 Tel. 919.851.6866  
 Fax. 919.851.7024  
 www.stantec.com  
 License No. F-0672

DocuSigned by  
 J.W. Woolard  
 58C02F4E95D0  
 NORTH CAROLINA PROFESSIONAL SEAL  
 19862  
 ENGINEER  
 J. W. WOOLARD, R.  
 7/24/2024

DIVISION OF HIGHWAYS  
 STATE OF NORTH CAROLINA  
 DEPARTMENT OF TRANSPORTATION  
 WORK ZONE TRAFFIC CONTROL

-L- NC 150  
 PHASE II  
 STEP 1

DOCUMENT NOT CONSIDERED FINAL  
 UNLESS ALL SIGNATURES COMPLETED

PROJ. REFERENCE NO.	SHEET NO.
R-2307B	TMP-70

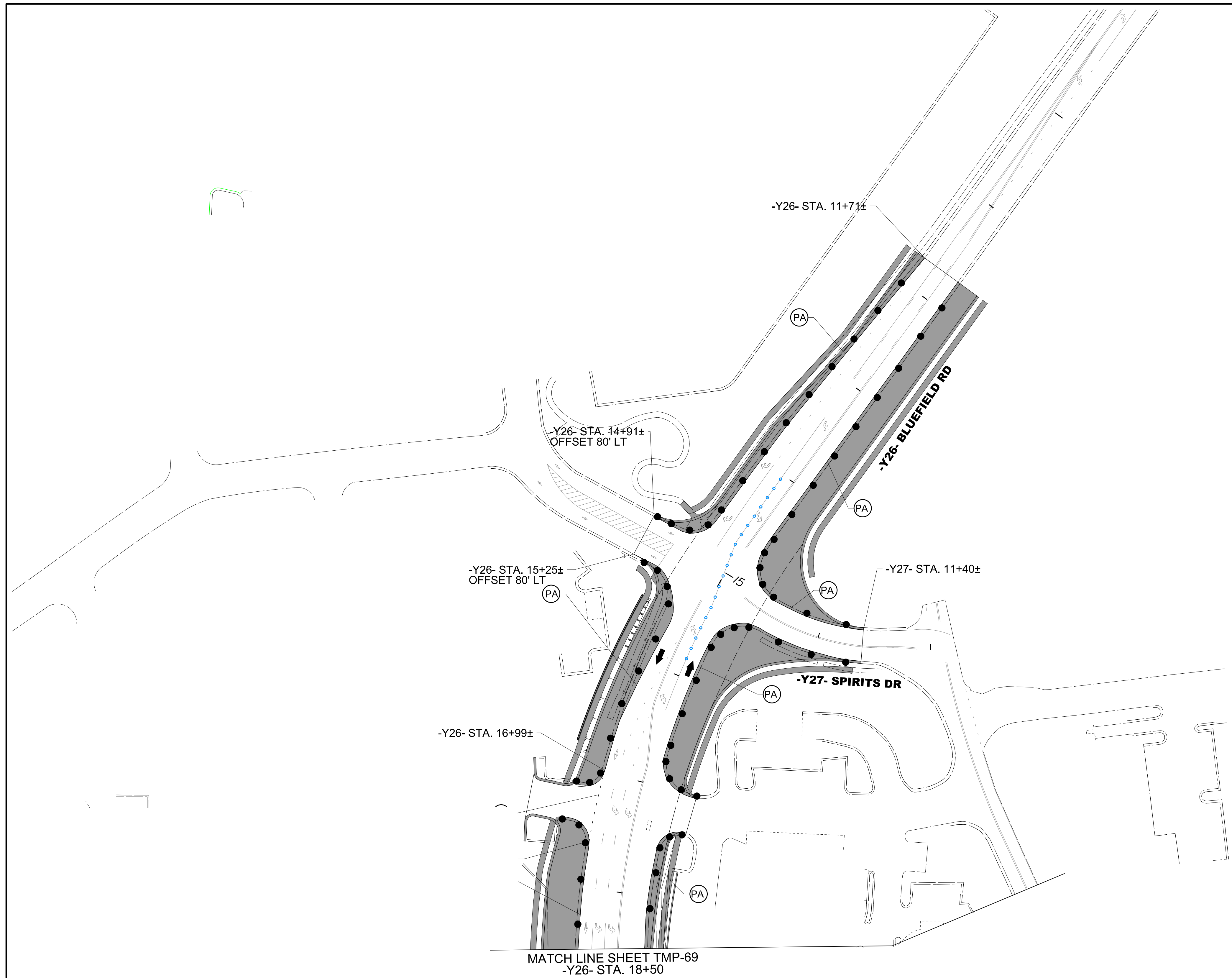
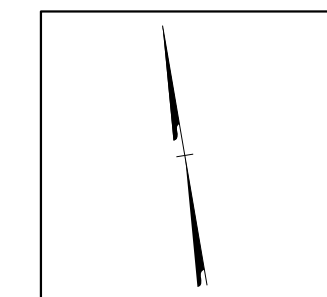

6/4/2024  
 U:\Traffic\Transportation Management\Plan\TCP\PLAN SHEETS\IR-2307B-TMP-70\_PHASE\_02\_STEP\_01.dgn  
 dorichardson

Stantec Consulting Services Inc.  
 801 Jones Franklin Road  
 Suite 300  
 Raleigh, NC 27606  
 Tel. 919.851.6866  
 Fax. 919.851.7024  
 www.stantec.com  
 License No. F-0672

DocuSigned by:  
 J.W. Woolard  
 919862  
 7/24/2024

**DOCUMENT NOT CONSIDERED FINAL  
 UNLESS ALL SIGNATURES COMPLETED**

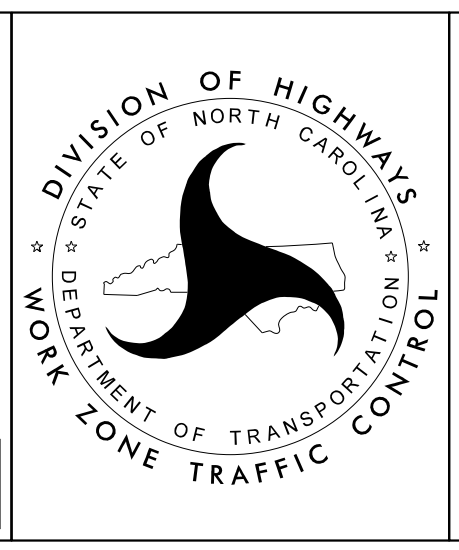

**-Y26- BLUEFIELD RD  
 PHASE II  
 STEP 1**

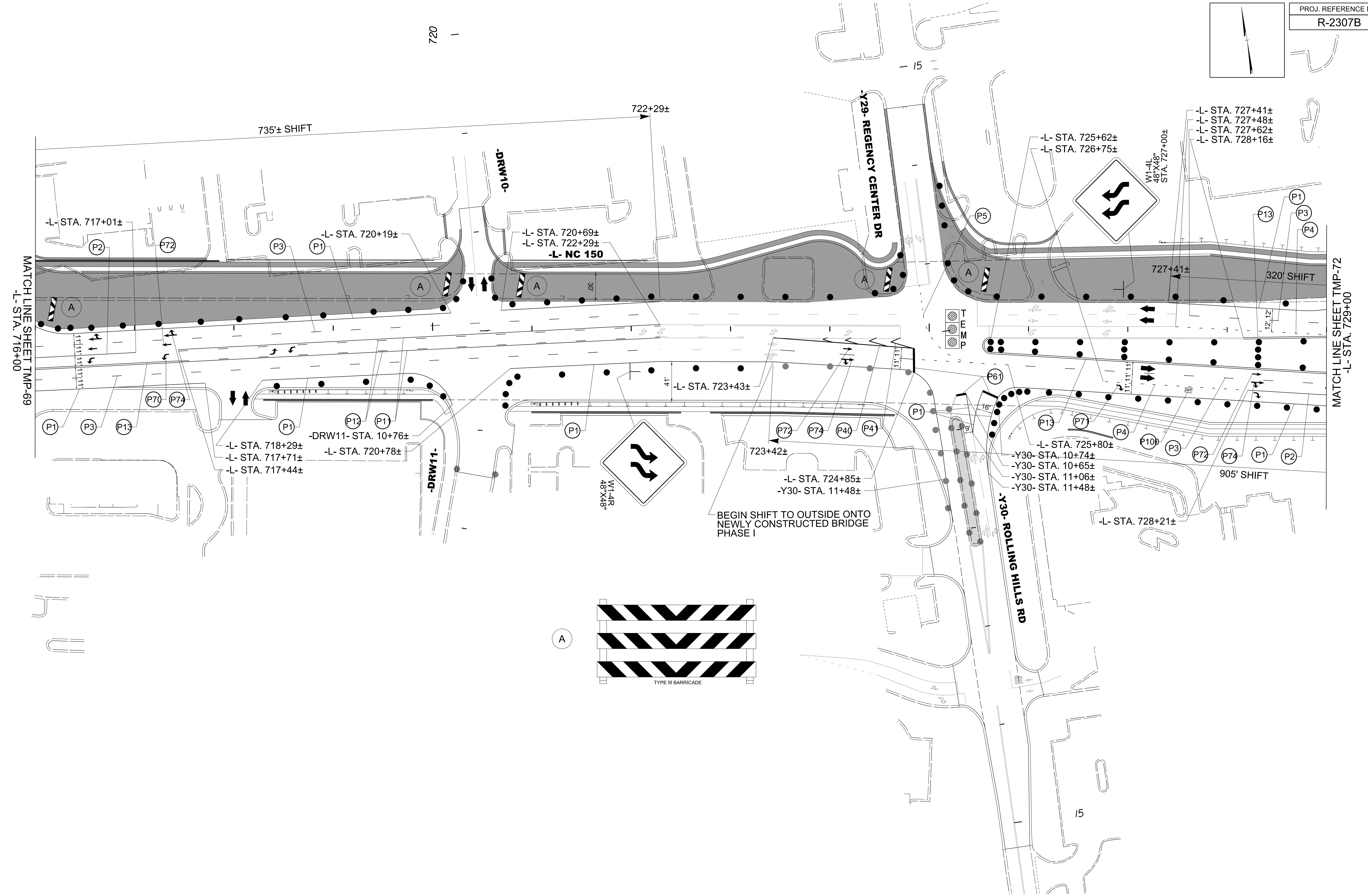

MATCH LINE SHEET TMP-69  
-L- STA. 716+00

MATCH LINE SHEET TMP-72  
-L- STA. 729+00

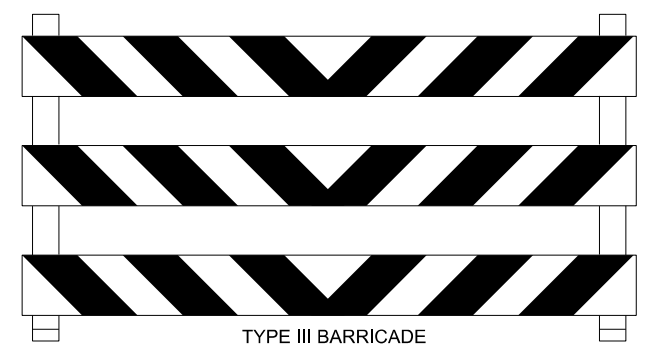

6/4/2024  
U:\Traffic\Transportation Management\Plan\TCP\PLAN SHEETS\IR-2307B-TMP-71-PHASE\_02-STEP-01.dgn  
dorichardson

**Stantec**

Stantec Consulting Services Inc.  
801 Jones Franklin Road  
Suite 300  
Raleigh, NC 27606  
Tel. 919.851.6866  
Fax. 919.851.7024  
www.stantec.com  
License No. F-0672

DocuSigned by  
J.W. Woolard  
8BC02F4E6930

7/24/2024

**DOCUMENT NOT CONSIDERED FINAL  
UNLESS ALL SIGNATURES COMPLETED**

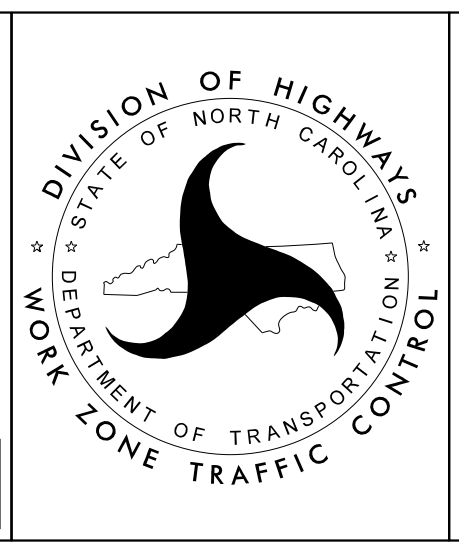

-L- NC 150  
PHASE II  
STEP 1

SEE TMP-72B FOR CROSS SECTION DETAILS

SEE TMP-72A FOR SHORING DETAILS

DURING BRIDGE WORK OVER I-77:

- USE -Y31RPC- TO -Y31RPD- AS NIGHTLY DETOUR FOR I-77NB TRAFFIC.
- USE -Y31RPA- TO -Y31RPB- AS NIGHTLY DETOUR FOR I-77SB TRAFFIC.

REFER TO RSD 1101.03 SHEET 7 OF 9 "ALL TRAFFIC EXIT CONDITION".

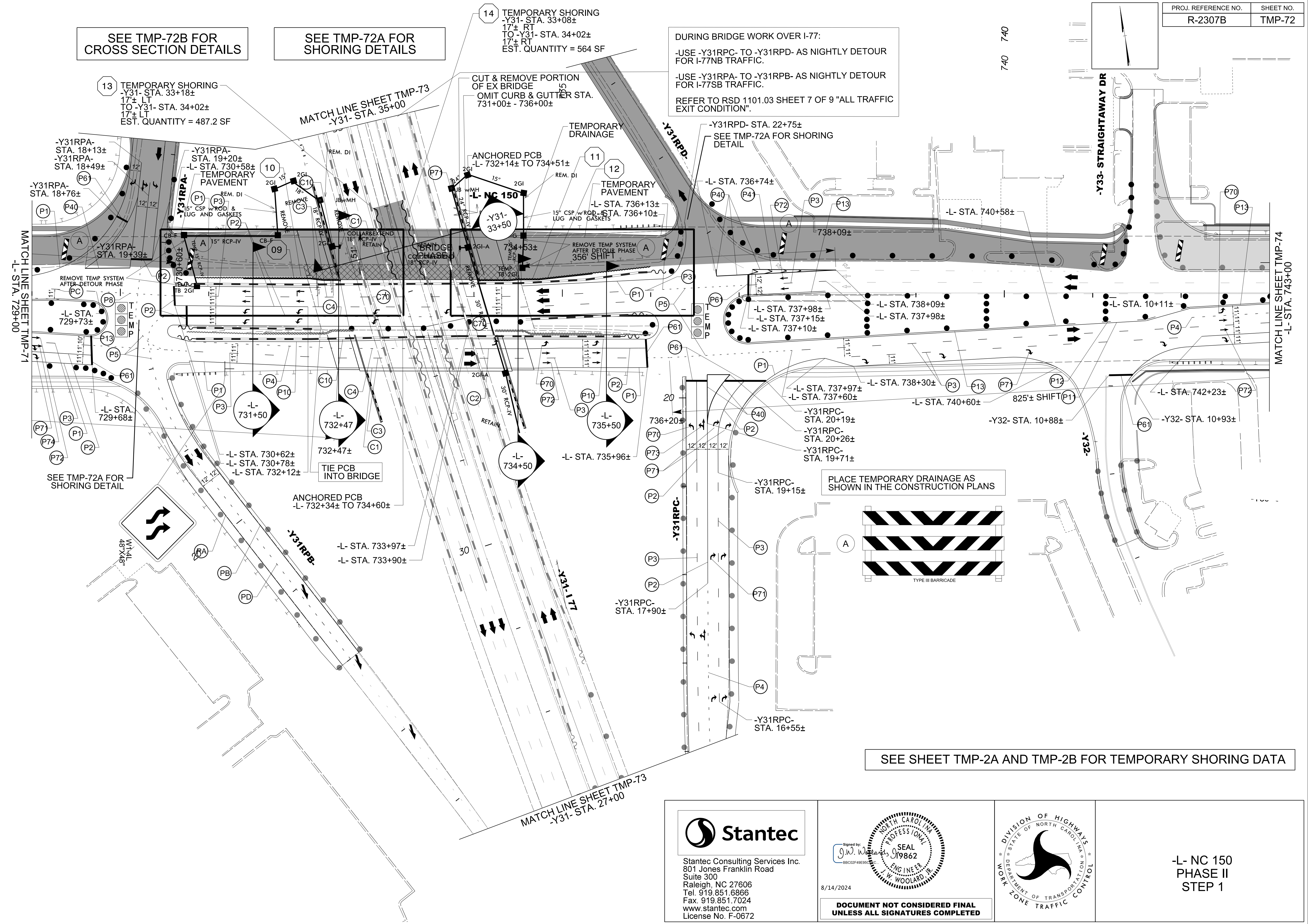

MATCH LINE SHEET TMP-71  
-L- STA. 729+00

MATCH LINE SHEET TMP-73  
-Y31- STA. 35+00

MATCH LINE SHEET TMP-73  
-Y31- STA. 27+00

MATCH LINE SHEET TMP-74  
-L- STA. 743+00

SEE SHEET TMP-2A AND TMP-2B FOR TEMPORARY SHORING DATA

8/14/2024  
L:\Traffic\Transportation Management\Plan\TCP\PLAN SHEETS\NR-2307B-TMP-72\_PHASE\_02\_STEP\_01.dgn  
angood

**Stantec**

Stantec Consulting Services Inc.  
801 Jones Franklin Road  
Suite 300  
Raleigh, NC 27606  
Tel. 919.851.6866  
Fax. 919.851.7024  
www.stantec.com  
License No. F-0672

Signed by:  
J.W. Woolard  
SEAL  
19862  
ENG INEE  
W. WOOLARD, R.

8/14/2024

**DOCUMENT NOT CONSIDERED FINAL  
UNLESS ALL SIGNATURES COMPLETED**

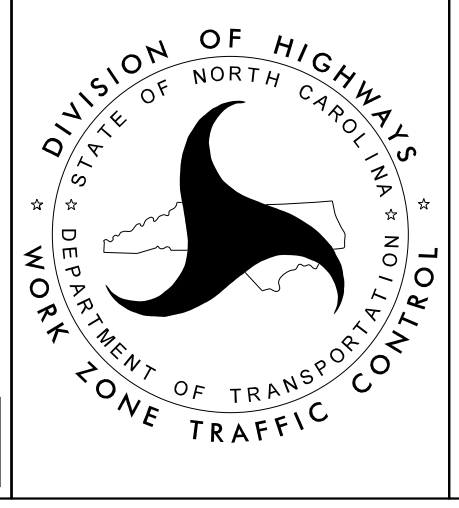

-L- NC 150  
PHASE II  
STEP 1

SEE SHEET TMP-2A & TMP-2B FOR TEMPORARY SHORING DATA

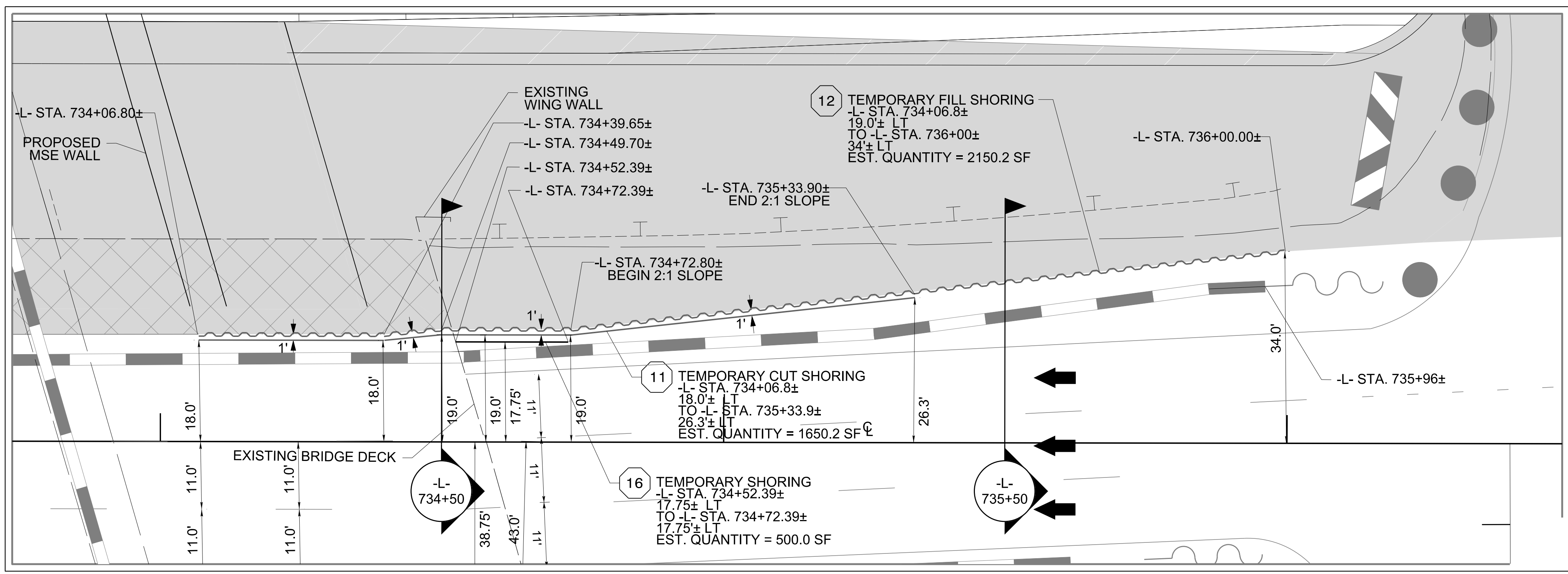
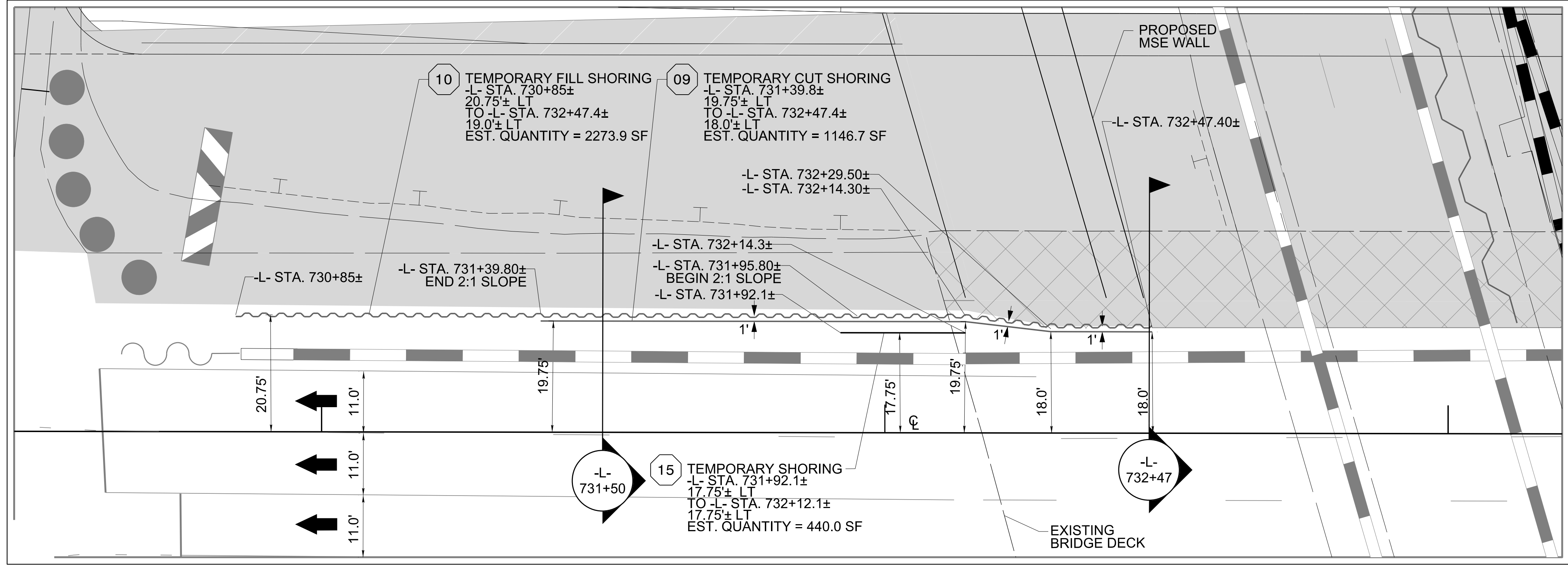

6/4/2024  
 U:\Traffic\Transportation Management\Plan\TCP\PLAN SHEETS\NR-2307B-TMP-72A-PHASE-02-STEP-01.dgn  
 dorichardson

**Stantec**  
 Stantec Consulting Services Inc.  
 801 Jones Franklin Road  
 Suite 300  
 Raleigh, NC 27606  
 Tel. 919.851.6866  
 Fax. 919.851.7024  
 www.stantec.com  
 License No. F-0672

DocuSigned by  
 J.W. Woolard, Jr.  
 5802746E950

PROFESSIONAL SEAL  
 19862  
 ENGINEER  
 W. WOOLARD, JR.

7/24/2024

**DOCUMENT NOT CONSIDERED FINAL  
 UNLESS ALL SIGNATURES COMPLETED**

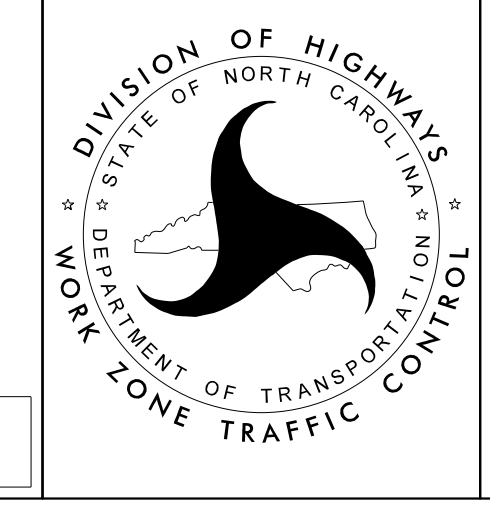

-L- NC 150  
 PHASE II  
 STEP 1  
 SHORING DETAILS

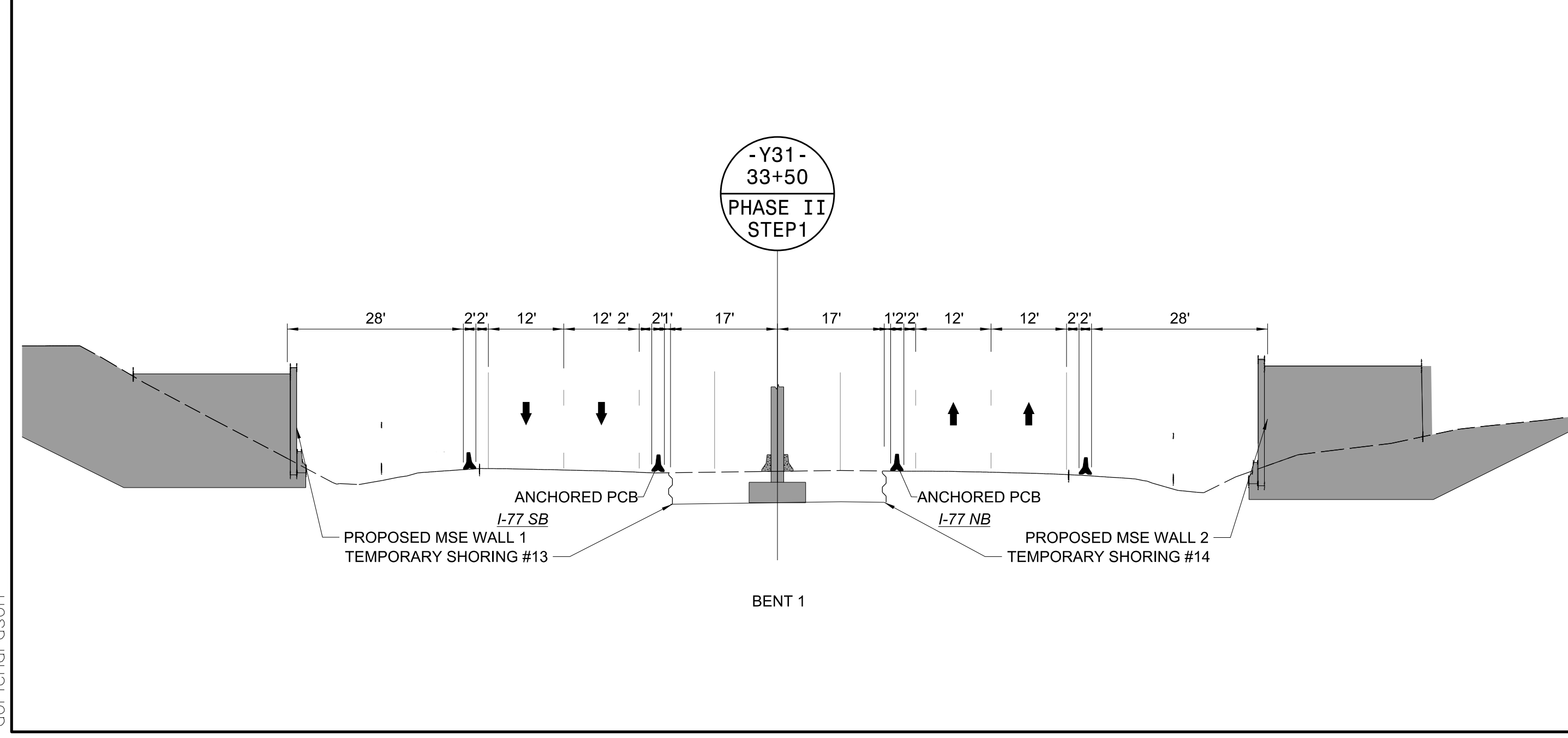
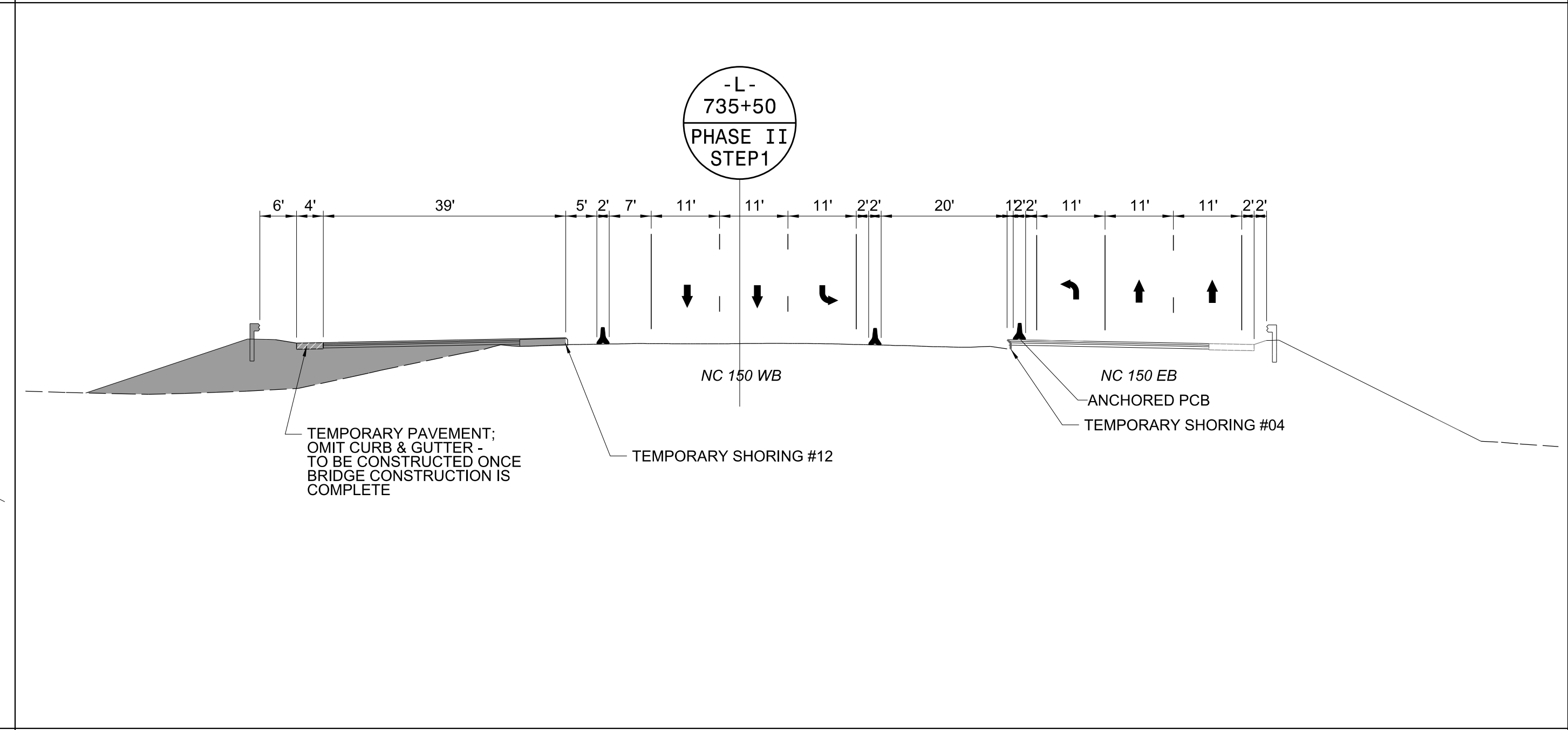
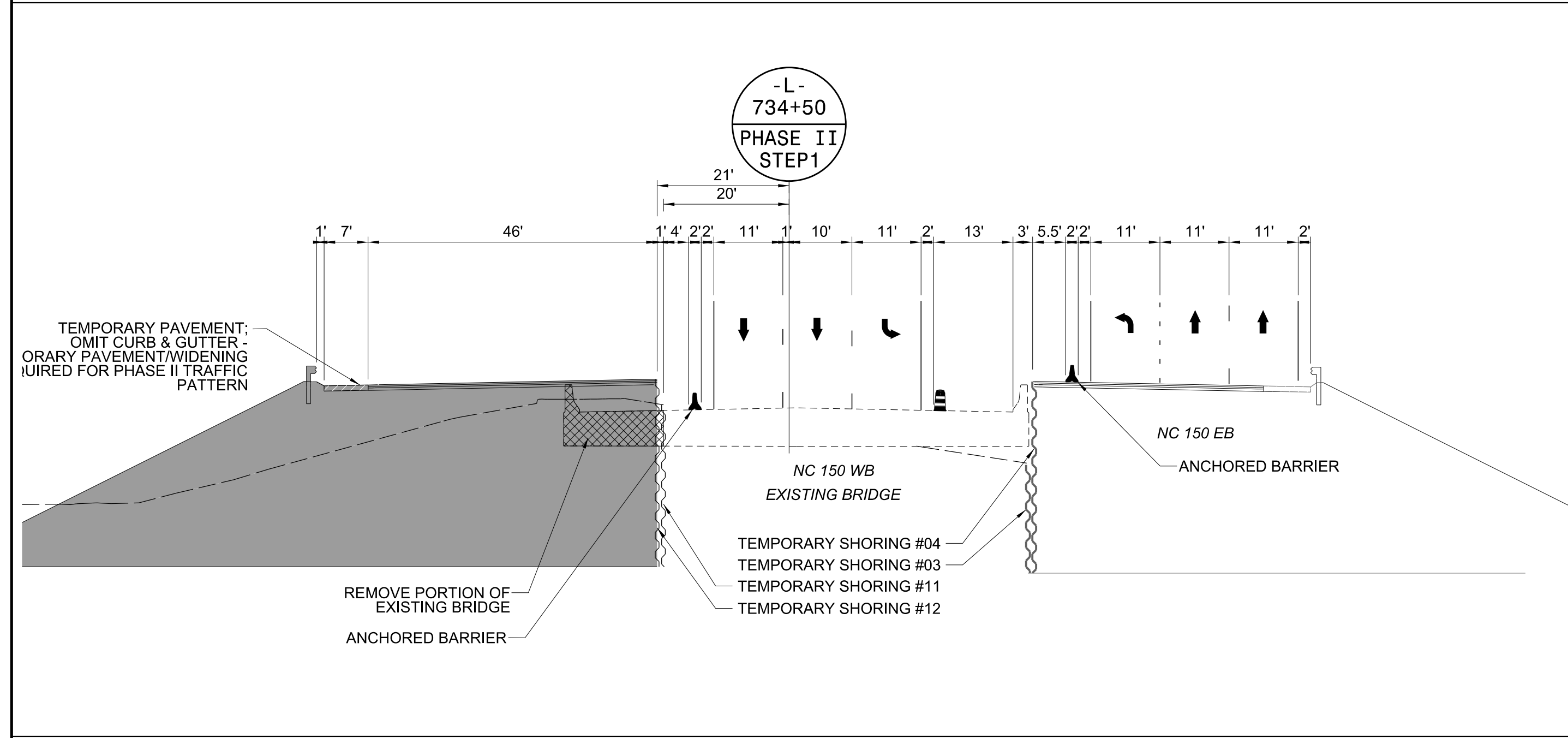
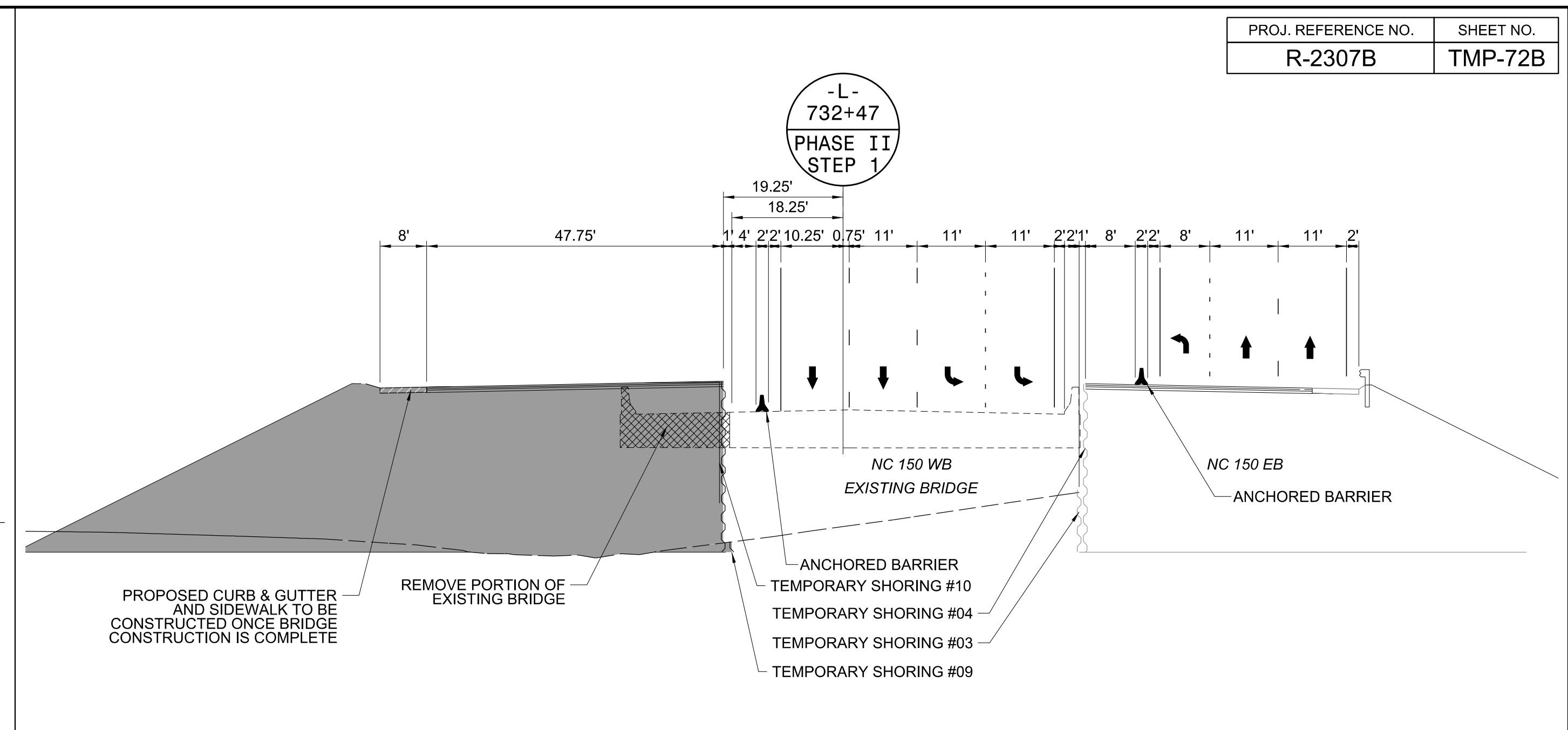
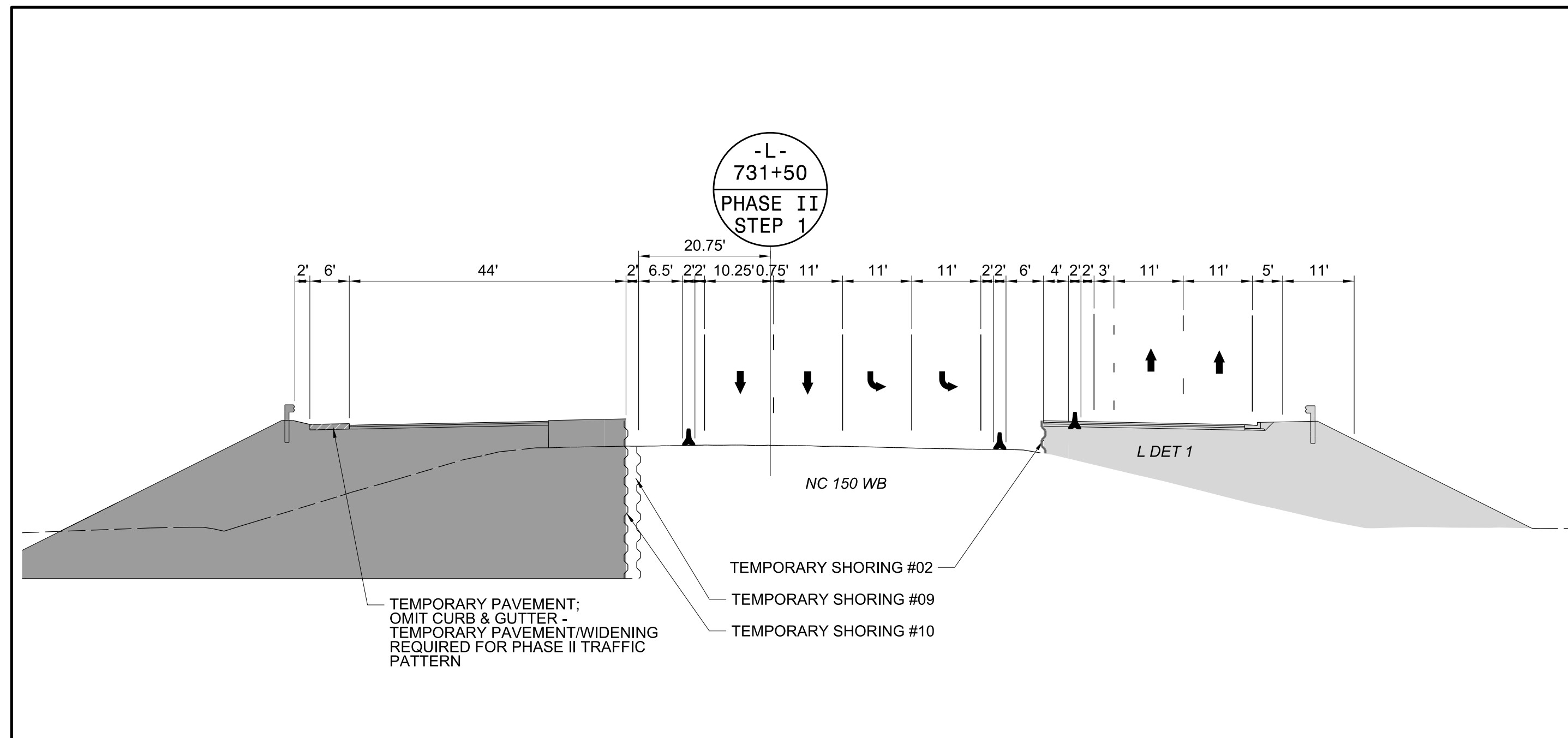

**Stantec**  
 Stantec Consulting Services Inc.  
 801 Jones Franklin Road  
 Suite 300  
 Raleigh, NC 27606  
 Tel. 919.851.6866  
 Fax. 919.851.7024  
 www.stantec.com  
 License No. F-0672

DocuSigned by  
 J.W. Woolard, R.  
 7/24/2024

SEAL  
 19862  
 W. WOOLARD, R.

**DOCUMENT NOT CONSIDERED FINAL  
 UNLESS ALL SIGNATURES COMPLETED**

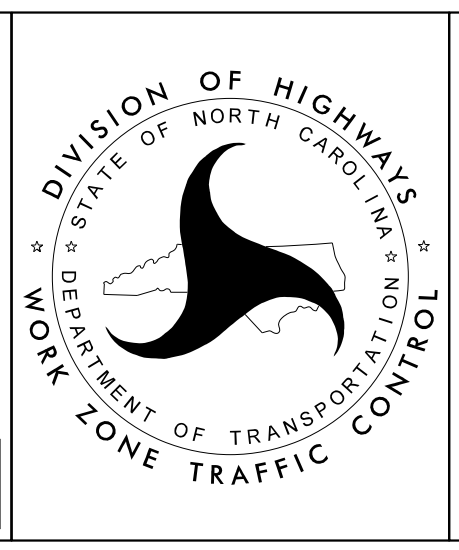

**-L- NC 150  
 PHASE II  
 STEP 1  
 CROSS SECTION DETAILS**

6/4/2024  
 U:\Traffic\Transportation Management Plan\TCP\PLAN SHEETS\IR-2307B-TMP-72B-PHASE.02-STEP-01.dgn  
 dorichardson

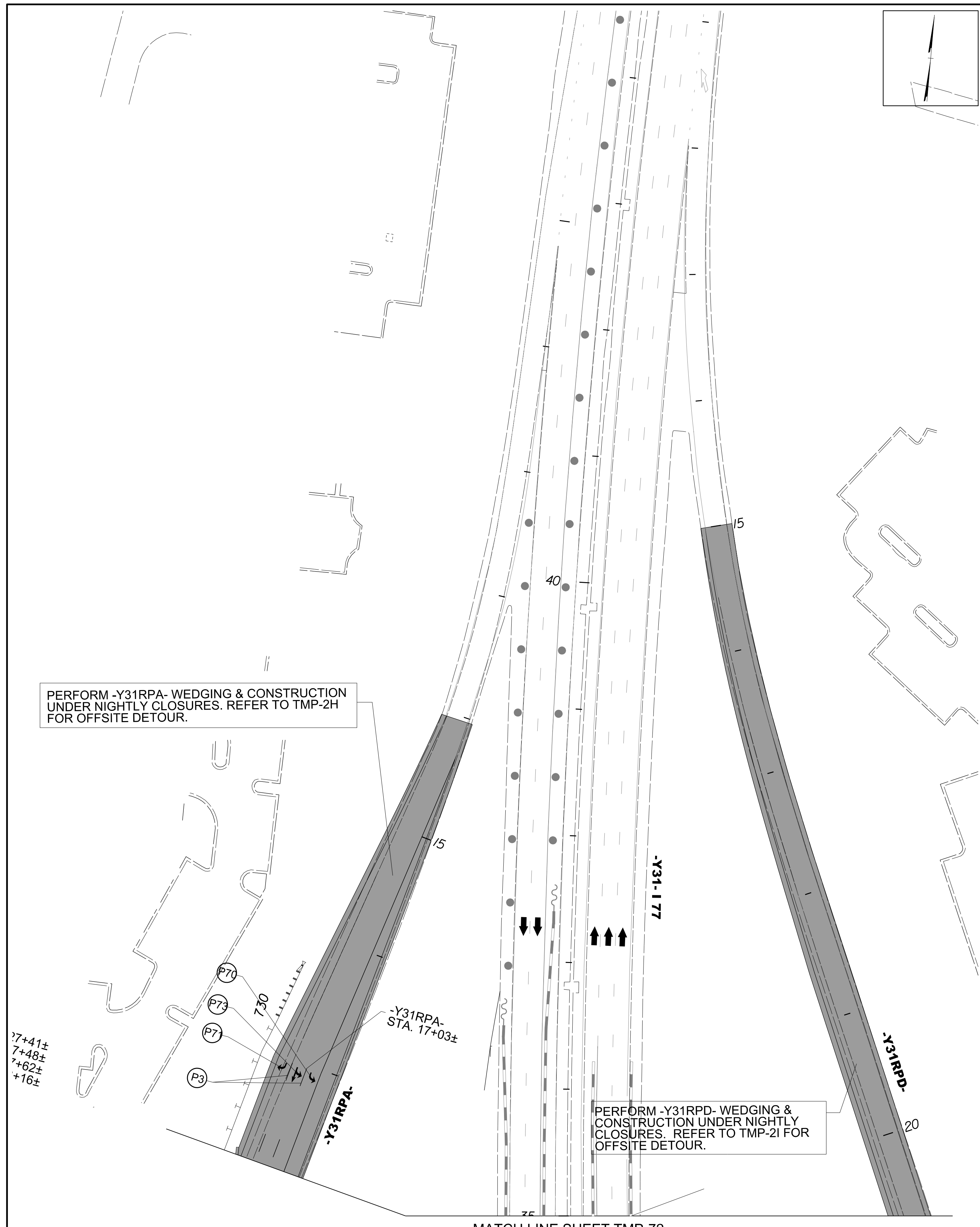

MATCH LINE SHEET TMP-72  
-Y31- STA. 35+00

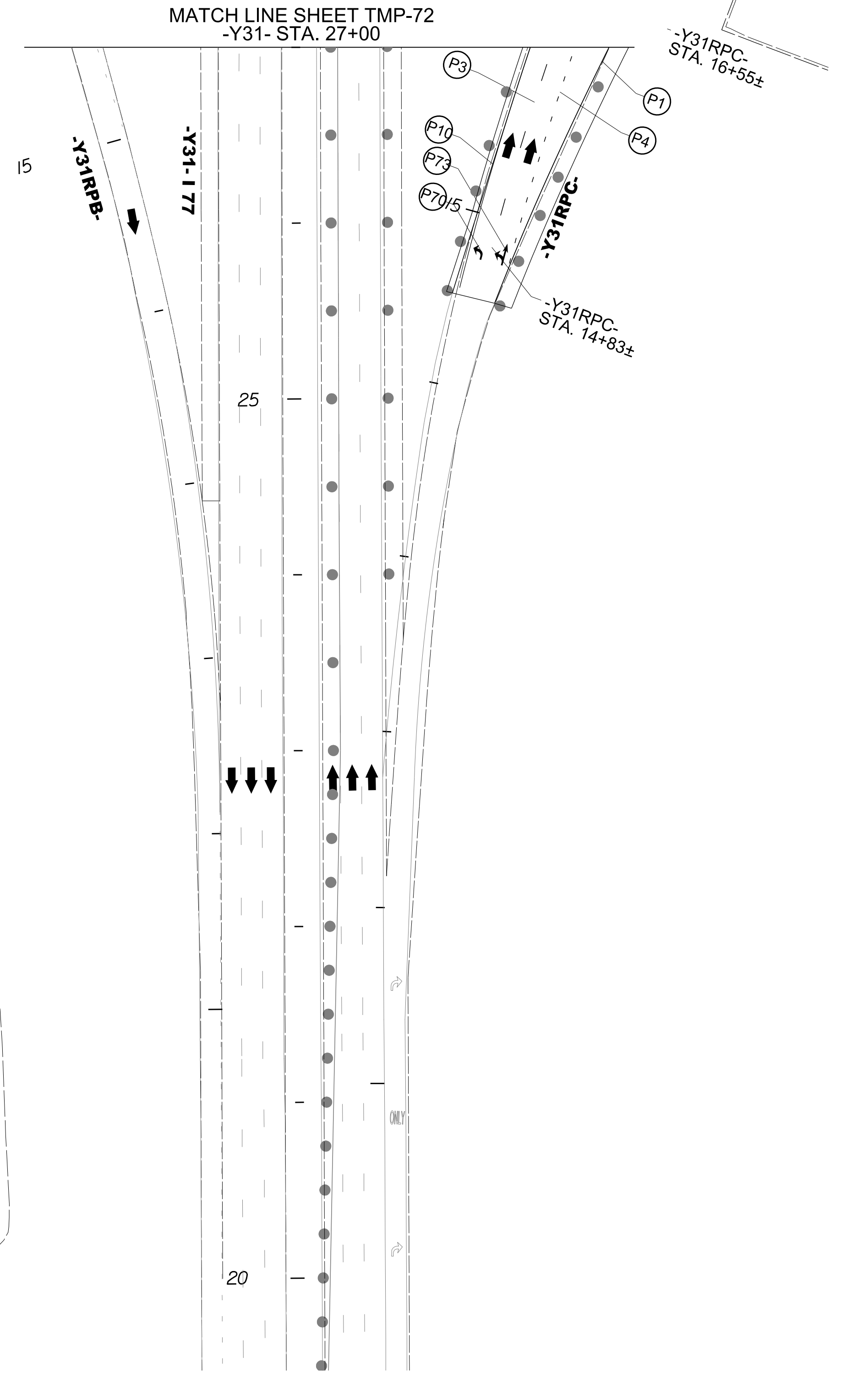

8/14/2024  
 U:\Traffic\Transportation Management Plan\TCP\PLAN SHEETS\IR-2307B-TMP-73\_PHASE\_02\_STEP\_01.dgn  
 angood

**Stantec**  
 Stantec Consulting Services Inc.  
 801 Jones Franklin Road  
 Suite 300  
 Raleigh, NC 27606  
 Tel. 919.851.6866  
 Fax. 919.851.7024  
 www.stantec.com  
 License No. F-0672

Signed by: *J.W. Williams*  
 SEAL 19862  
 ENGINEER  
 W. WOOLARD, R.  
 8/14/2024

DIVISION OF HIGHWAYS  
 STATE OF NORTH CAROLINA  
 DEPARTMENT OF TRANSPORTATION  
 WORK ZONE TRAFFIC CONTROL

-L- NC 150  
 PHASE II  
 STEP 1

**DOCUMENT NOT CONSIDERED FINAL  
 UNLESS ALL SIGNATURES COMPLETED**



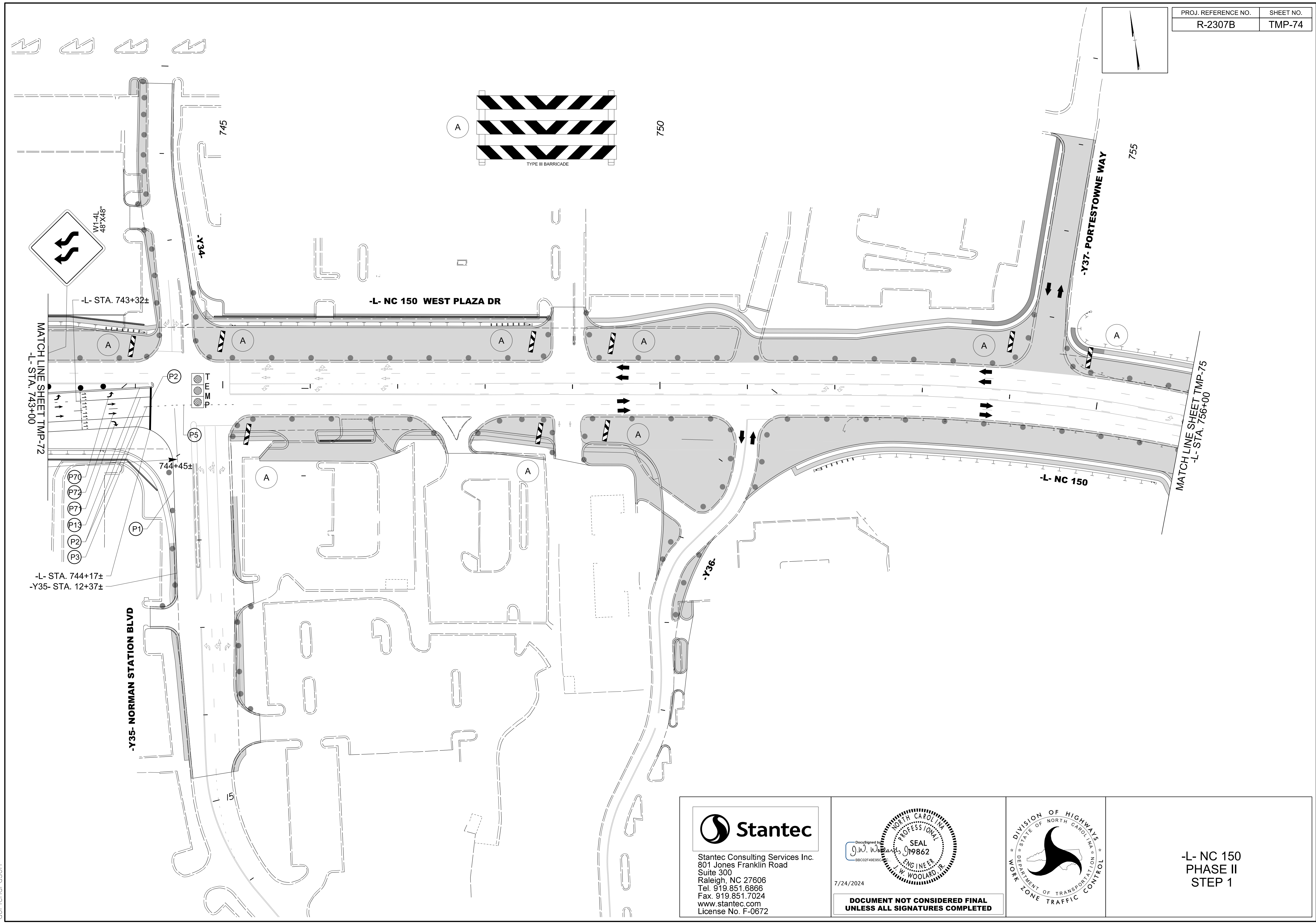

6/4/2024  
 U:\Traffic\Transportation Management Plan\TCP\PLAN SHEETS\NR-2307B-TMP-74\_PHASE\_02\_STEP\_01.dgn  
 dorichardson

**Stantec**  
 Stantec Consulting Services Inc.  
 801 Jones Franklin Road  
 Suite 300  
 Raleigh, NC 27606  
 Tel. 919.851.6866  
 Fax. 919.851.7024  
 www.stantec.com  
 License No. F-0672

DocuSigned by  
 J.W. Woolard  
 7/24/2024

SEAL  
 PROFESSIONAL ENGINEER  
 J.W. WOOLARD, R.  
 19862

**DOCUMENT NOT CONSIDERED FINAL  
 UNLESS ALL SIGNATURES COMPLETED**

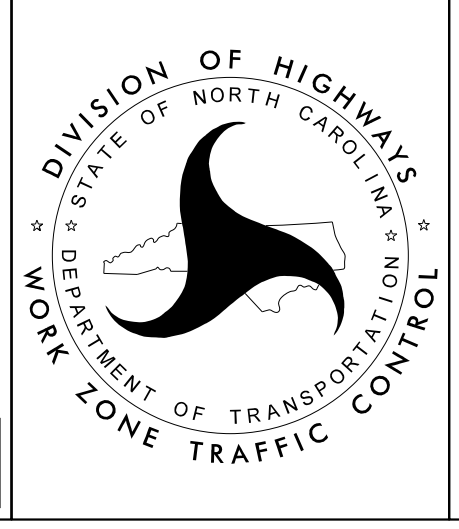

-L- NC 150  
 PHASE II  
 STEP 1

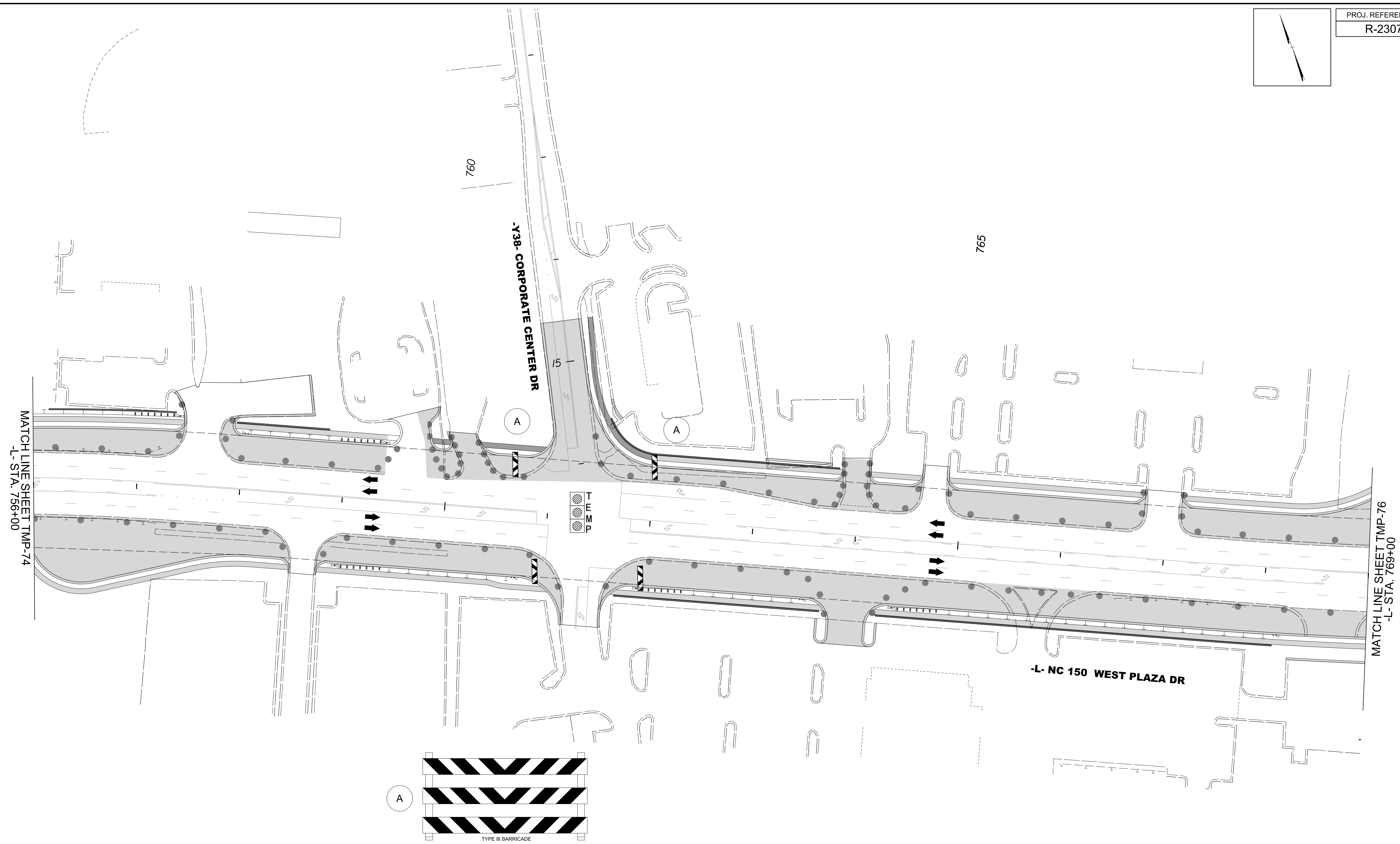
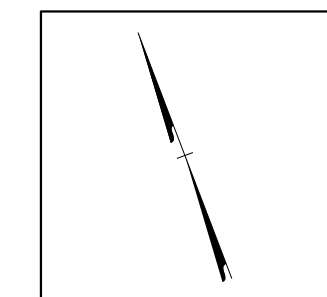

6/4/2024  
 U:\Traffic\Transportation Management Plan\TCP\PLAN SHEETS\IR-2307B-TMP-75\_PHASE\_02\_STEP\_01.dgn  
 dorichardson

  
 Stantec Consulting Services Inc.  
 801 Jones Franklin Road  
 Suite 300  
 Raleigh, NC 27606  
 Tel. 919.851.6866  
 Fax. 919.851.7024  
 www.stantec.com  
 License No. F-0672

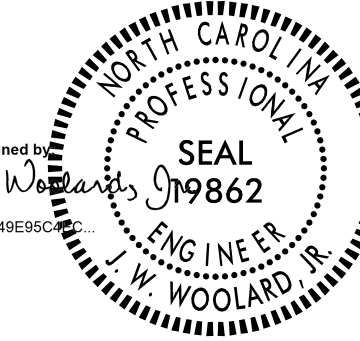
DocuSigned by  
  
 7/24/2024  
**DOCUMENT NOT CONSIDERED FINAL  
 UNLESS ALL SIGNATURES COMPLETED**

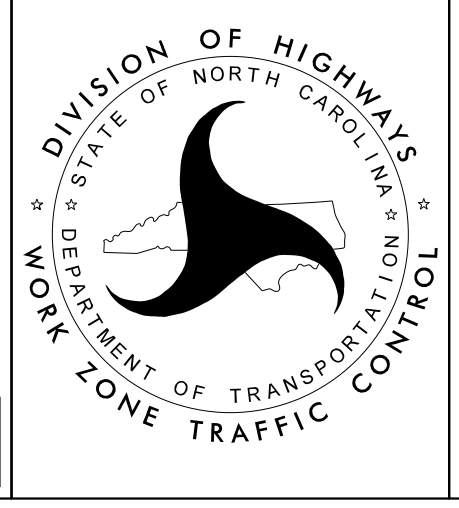

**-L- NC 150  
 PHASE II  
 STEP 1**

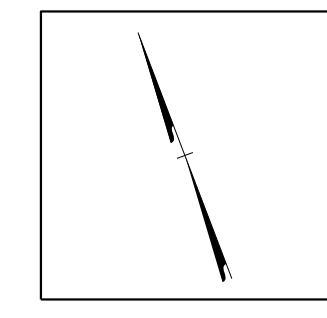

6/4/2024  
 U:\Traffic\Transportation Management Plan\TCP\PLAN SHEETS\IR-2307B-TMP-76\_PHASE\_02\_STEP\_01.dgn  
 dorichardson

  
 Stantec Consulting Services Inc.  
 801 Jones Franklin Road  
 Suite 300  
 Raleigh, NC 27606  
 Tel. 919.851.6866  
 Fax. 919.851.7024  
 www.stantec.com  
 License No. F-0672

7/24/2024  
  
**DOCUMENT NOT CONSIDERED FINAL  
 UNLESS ALL SIGNATURES COMPLETED**

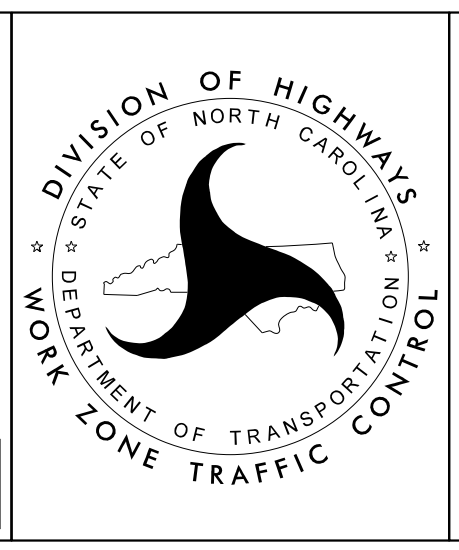

**-L- NC 150  
 PHASE II  
 STEP 1**

PROJ. REFERENCE NO.	SHEET NO.
R-2307B	TMP-77

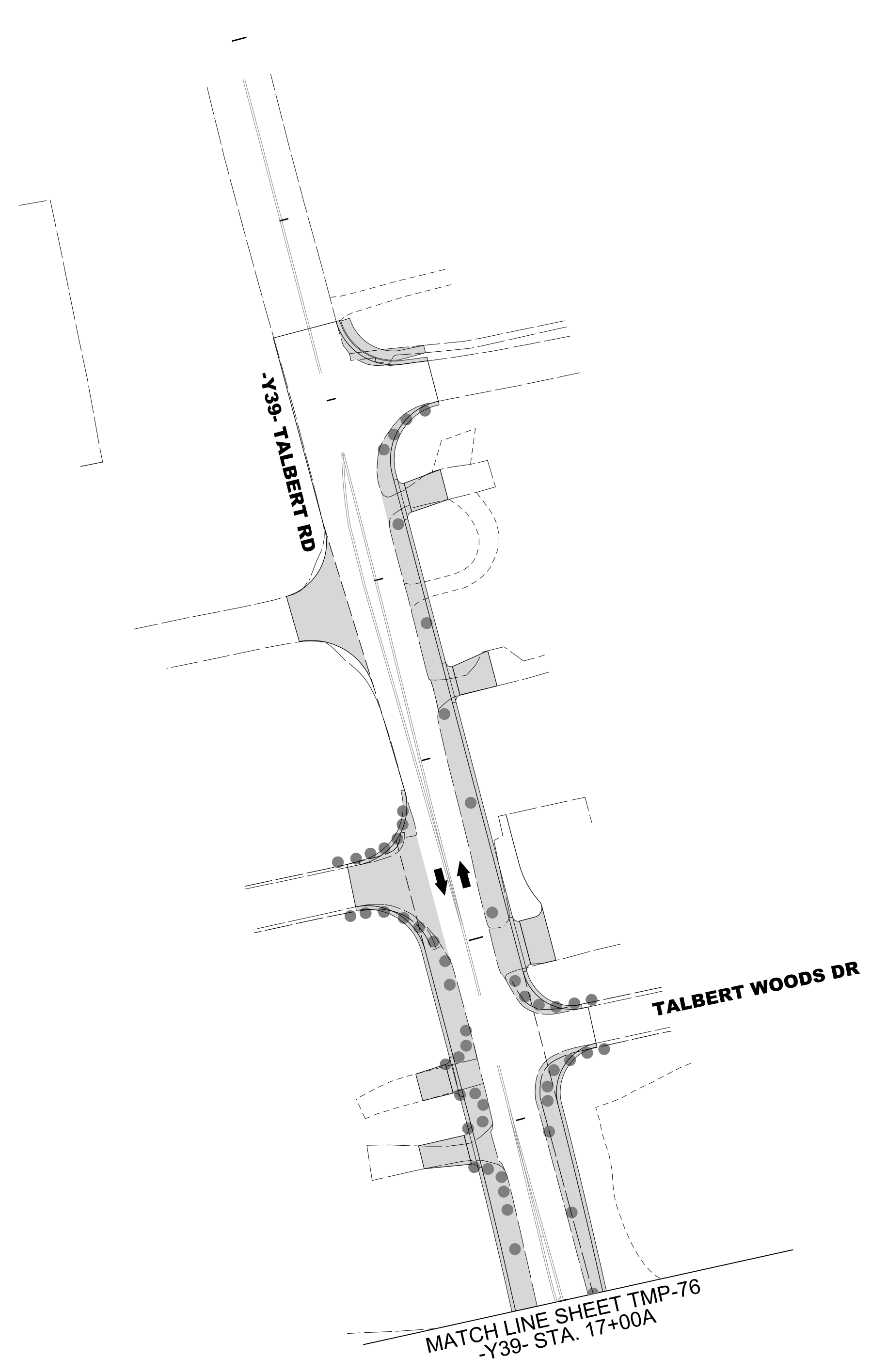
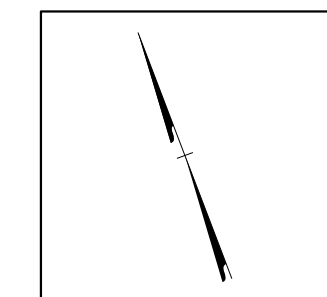
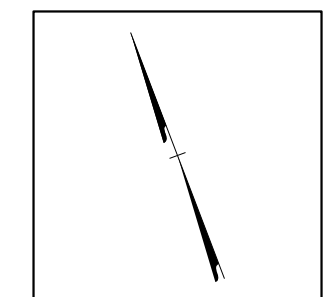

15

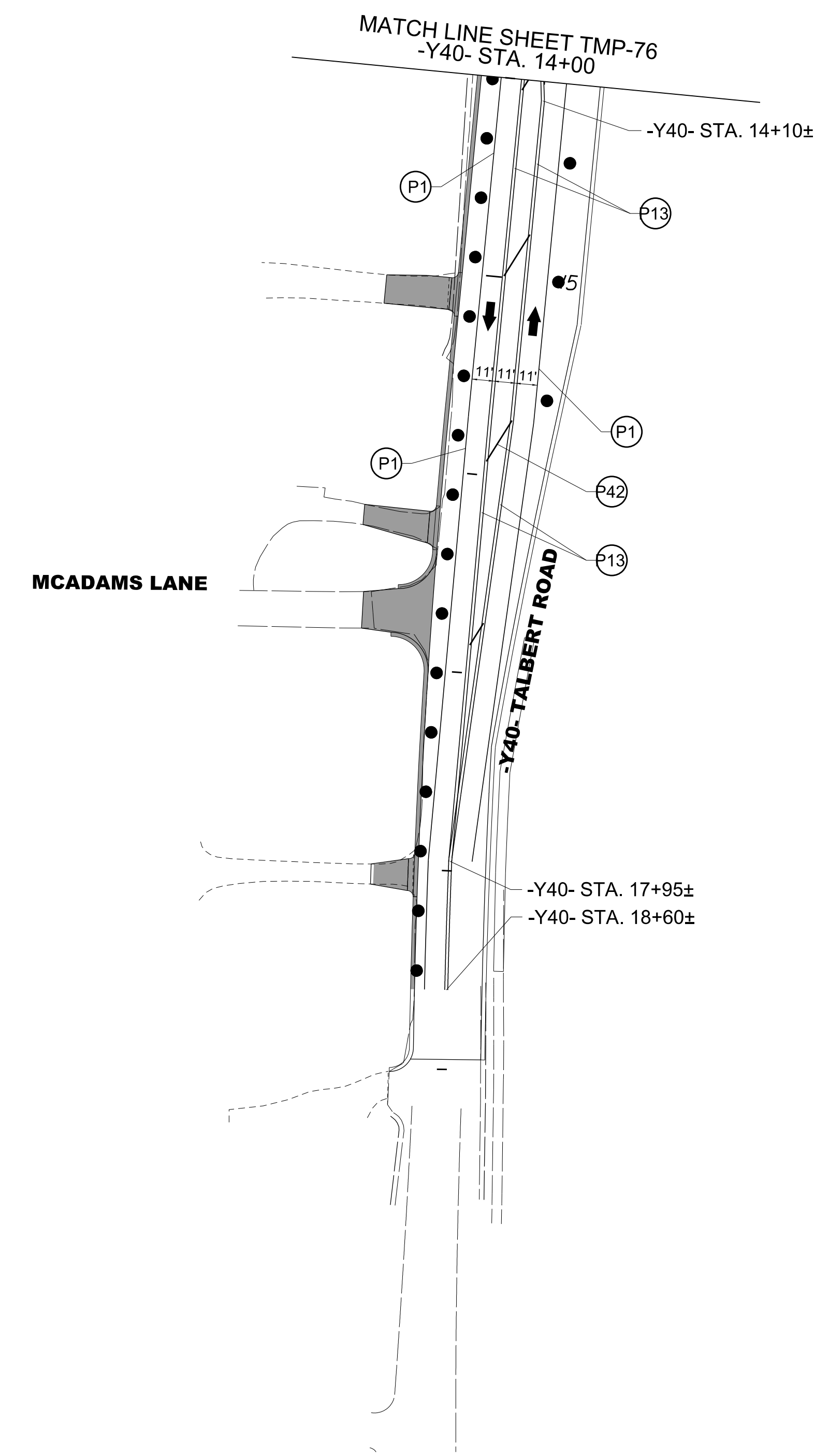

6/4/2024  
 U:\Traffic\Transportation Management\Plan\TCP\PLAN SHEETS\IR-2307B-TMP-77\_PHASE\_02\_STEP\_01.dgn  
 dorichardson

Stantec Consulting Services Inc.  
 801 Jones Franklin Road  
 Suite 300  
 Raleigh, NC 27606  
 Tel. 919.851.6866  
 Fax. 919.851.7024  
 www.stantec.com  
 License No. F-0672

DocuSigned by  
*J.W. Woolard*  
 88C02F49E95C

7/24/2024

**DOCUMENT NOT CONSIDERED FINAL  
 UNLESS ALL SIGNATURES COMPLETED**

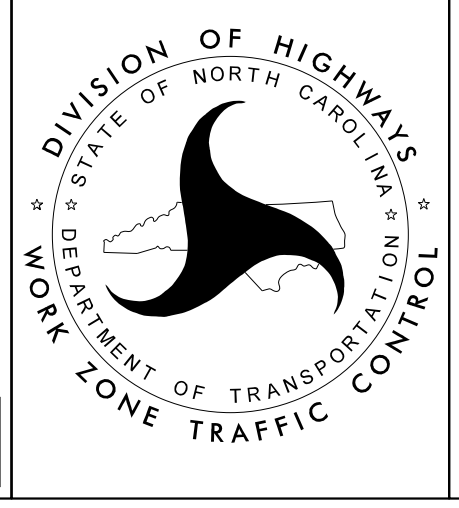

-L- NC 150  
 PHASE II  
 STEP 1

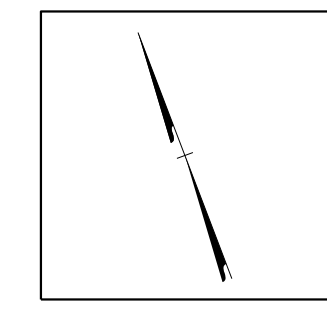

795

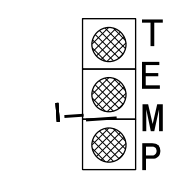
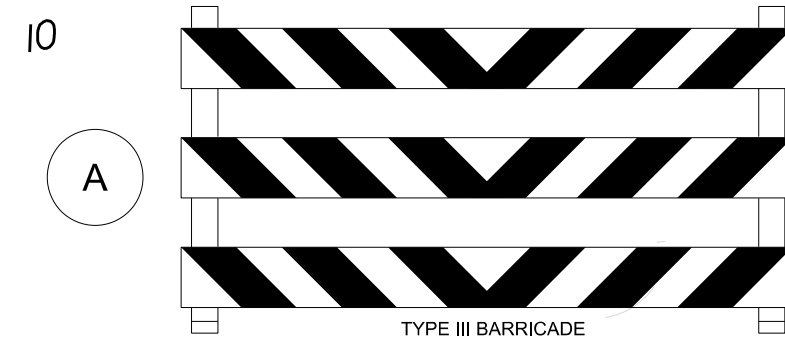
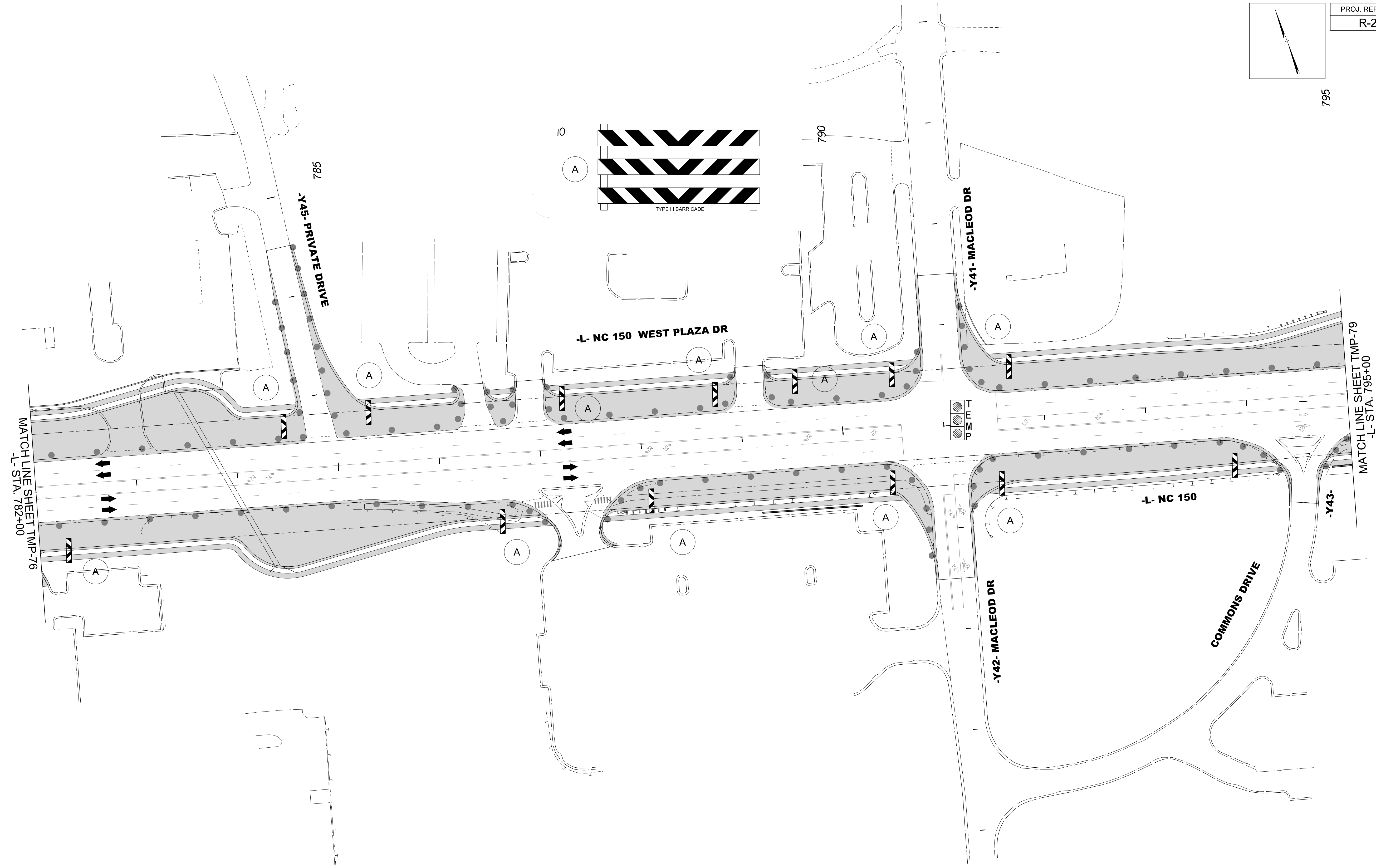

6/4/2024  
 U:\Traffic\Transportation Management\Plan\TCP\PLAN SHEETS\IR-2307B-TMP-78\_PHASE\_02\_STEP\_01.dgn  
 dorichardson

**Stantec**  
 Stantec Consulting Services Inc.  
 801 Jones Franklin Road  
 Suite 300  
 Raleigh, NC 27606  
 Tel. 919.851.6866  
 Fax. 919.851.7024  
 www.stantec.com  
 License No. F-0672

DocuSigned by  
*J.W. Woolard*  
 88C02F48E9C

7/24/2024

**DOCUMENT NOT CONSIDERED FINAL  
 UNLESS ALL SIGNATURES COMPLETED**

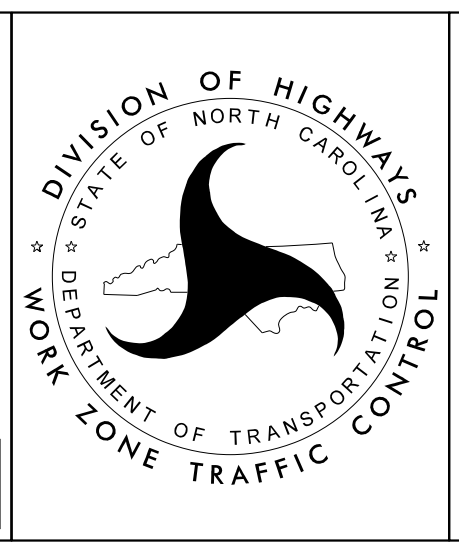

**-L- NC 150  
 PHASE II  
 STEP 1**

PROJ. REFERENCE NO.	SHEET NO.
R-2307B	TMP-79

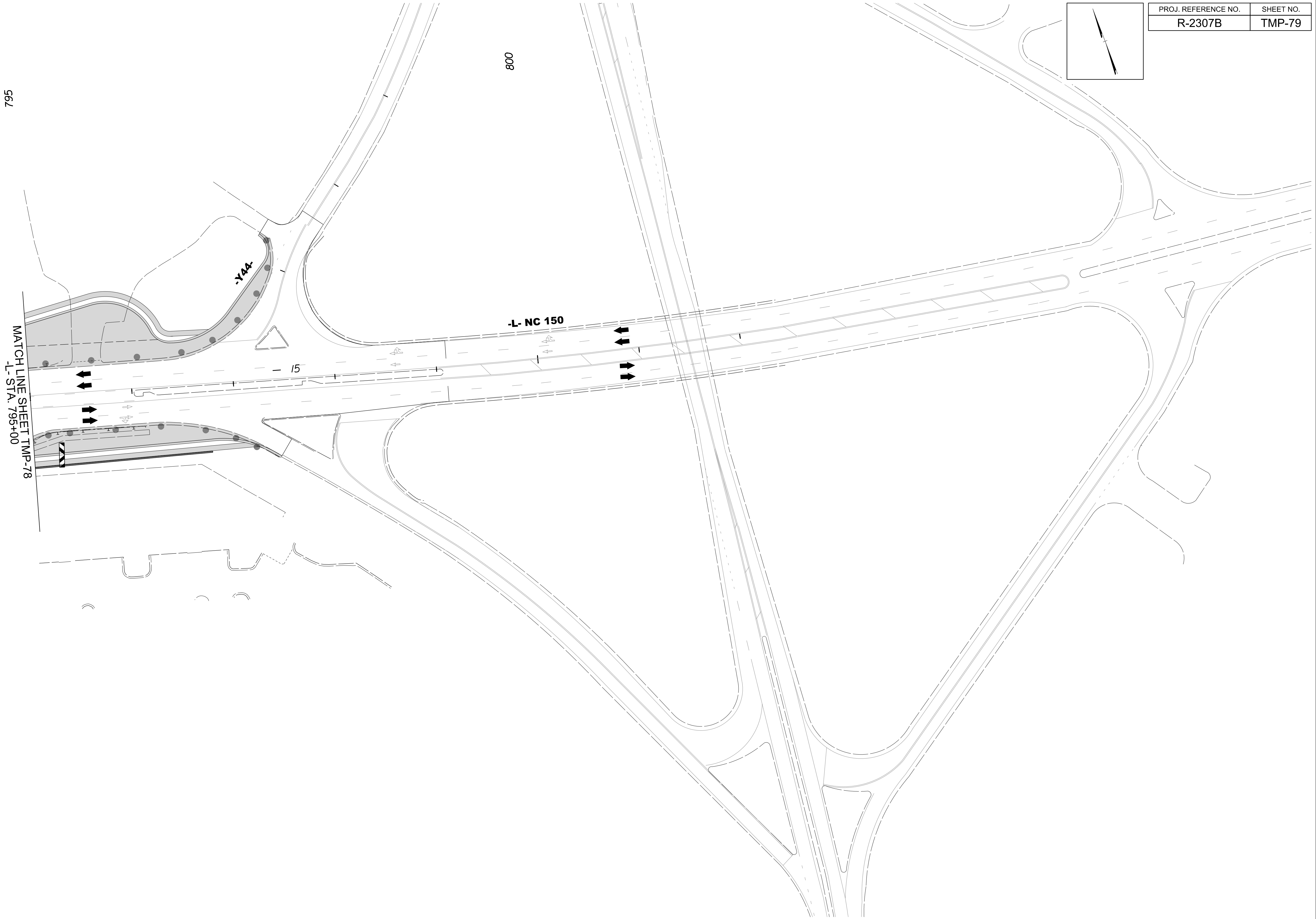
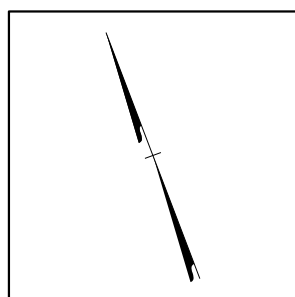

6/4/2024  
 U:\Traffic\Transportation Management\Plan\TCP\PLAN SHEETS\IR-2307B-TMP-79\_PHASE\_02\_STEP\_01.dgn  
 dorichardson

Stantec Consulting Services Inc.  
 801 Jones Franklin Road  
 Suite 300  
 Raleigh, NC 27606  
 Tel. 919.851.6866  
 Fax. 919.851.7024  
 www.stantec.com  
 License No. F-0672

Documented by  
*J.W. Woolard*  
 7/24/2024  
 PROFESSIONAL SEAL  
 19862  
 ENGINEER  
 W. WOOLARD, R.

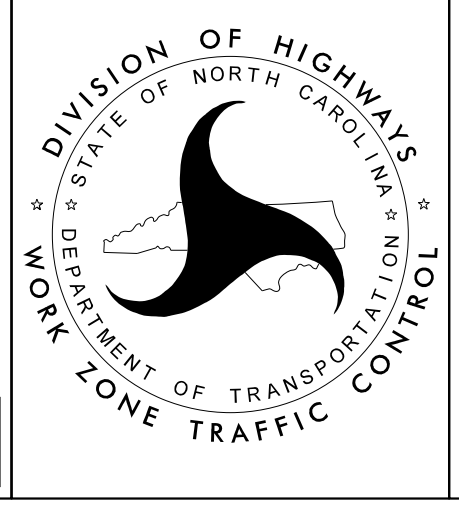

-L- NC 150  
 PHASE II  
 STEP 1

**DOCUMENT NOT CONSIDERED FINAL  
 UNLESS ALL SIGNATURES COMPLETED**

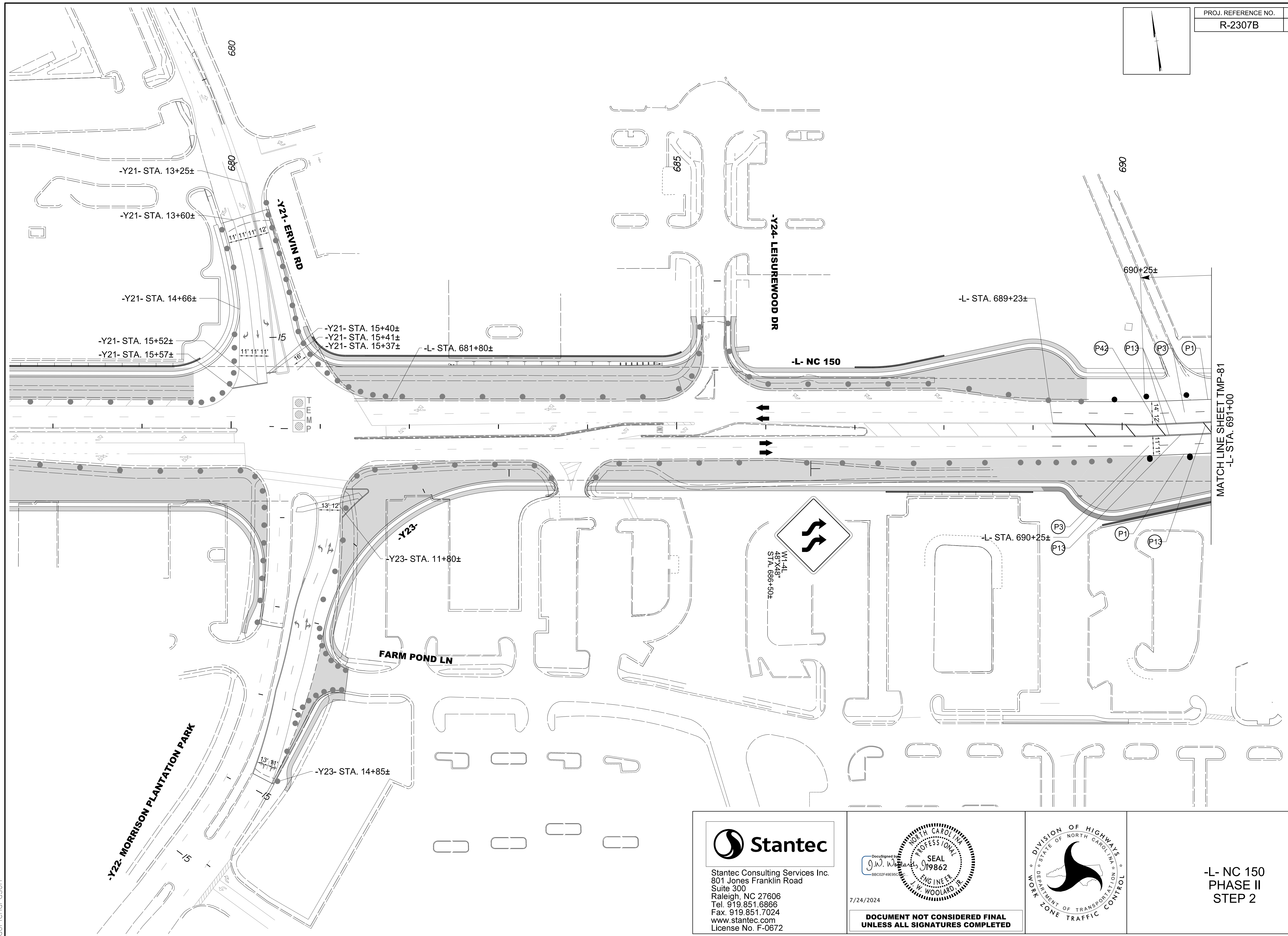
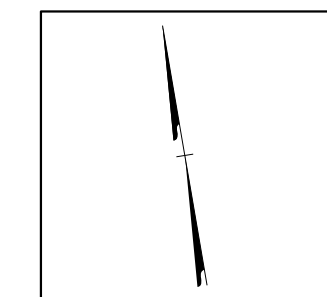

6/4/2024  
 U:\Traffic\Transportation Management Plan\TCP\PLAN SHEETS\IR-2307B-TMP\_80\_PHASE\_02\_STEP\_02.dgn  
 dorichardson

  
 Stantec Consulting Services Inc.  
 801 Jones Franklin Road  
 Suite 300  
 Raleigh, NC 27606  
 Tel. 919.851.6866  
 Fax. 919.851.7024  
 www.stantec.com  
 License No. F-0672

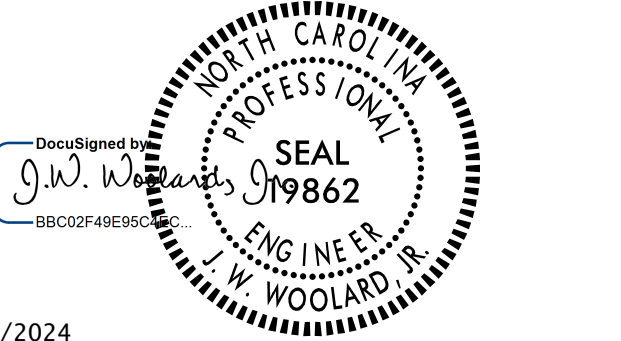
7/24/2024  
  
**DOCUMENT NOT CONSIDERED FINAL  
 UNLESS ALL SIGNATURES COMPLETED**

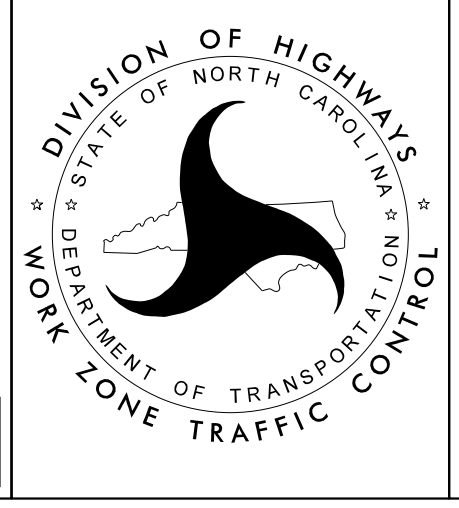

-L- NC 150  
 PHASE II  
 STEP 2

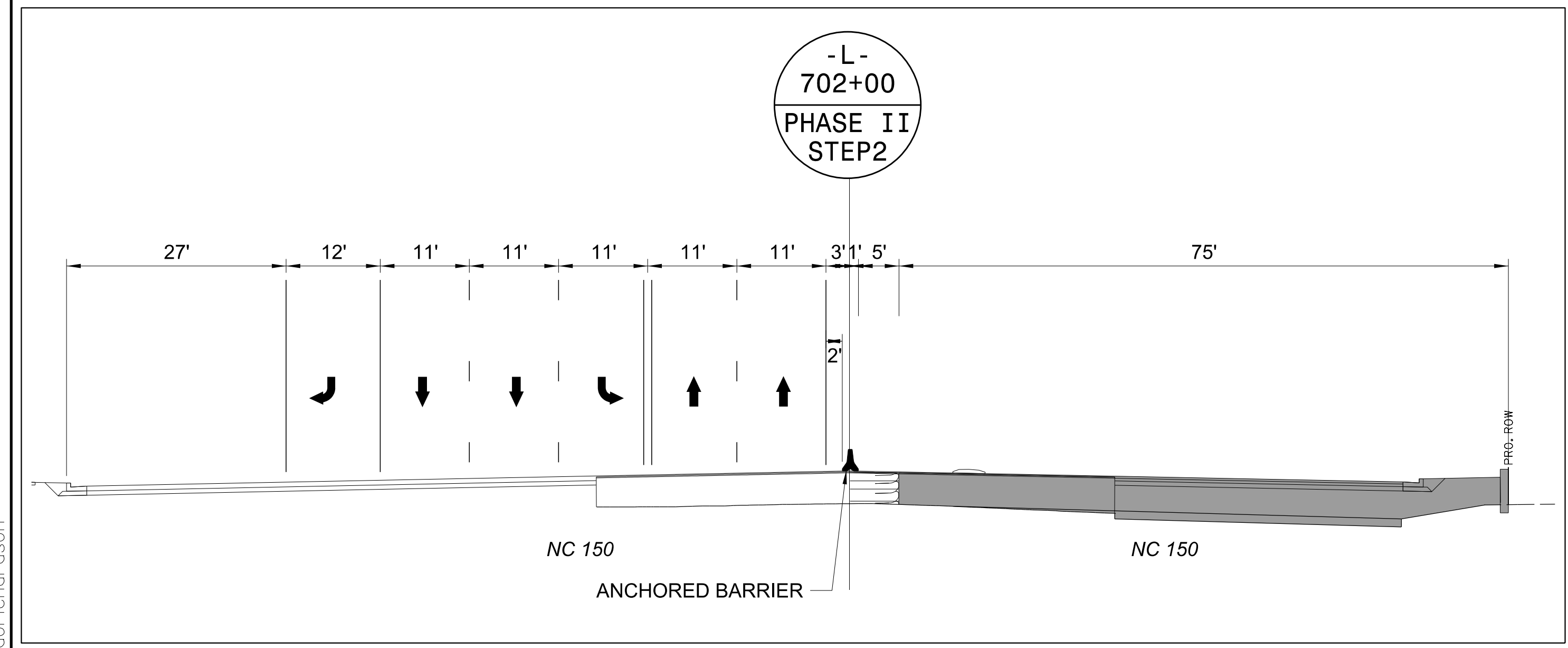
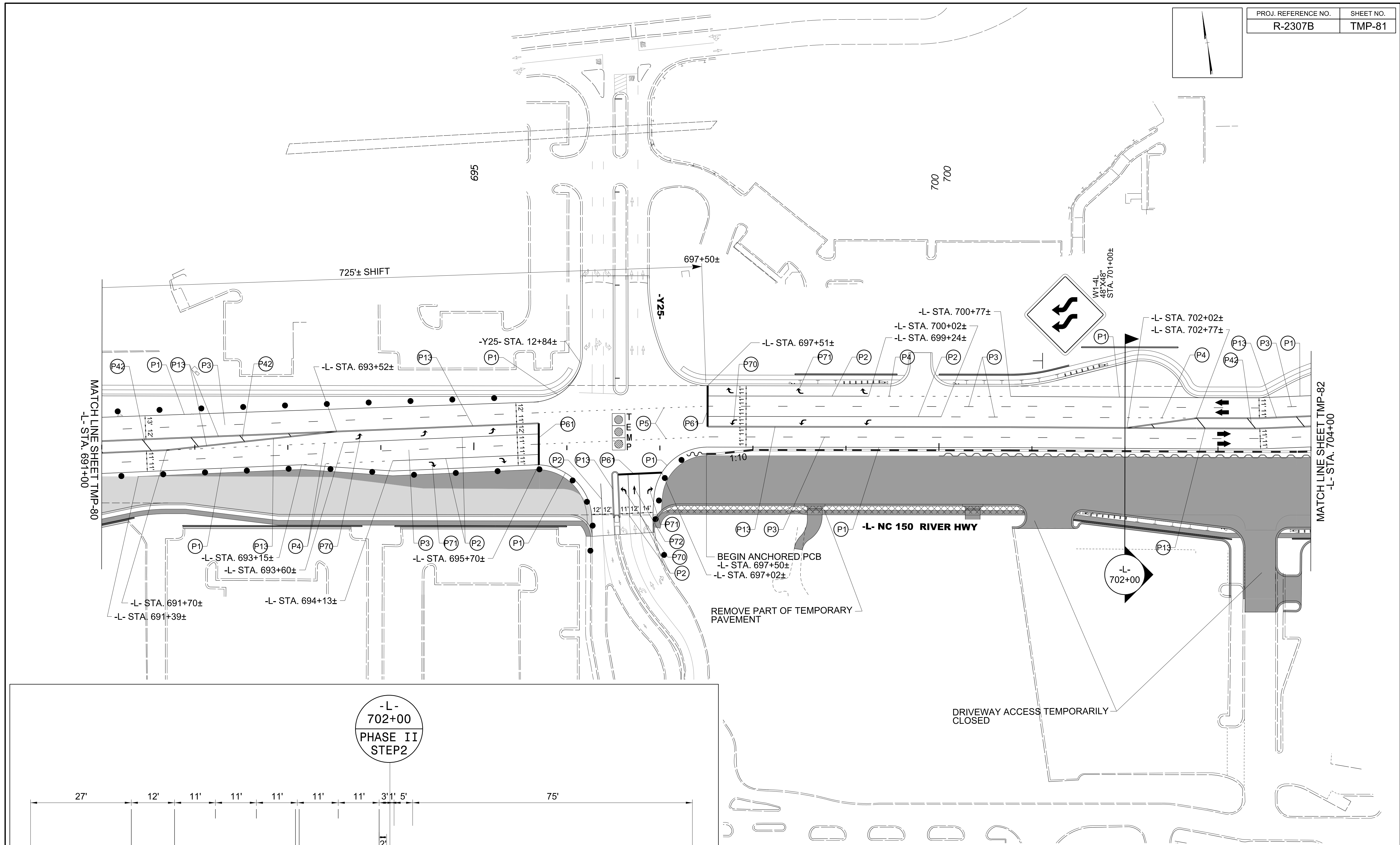

6/4/2024  
 U:\Traffic\Transportation Management\Plan\TCP\PLAN SHEETS\IR-2307B-TMP-81\PHASE\_02\_STEP\_02.dgn  
 dorichardson

**Stantec**  
 Stantec Consulting Services Inc.  
 801 Jones Franklin Road  
 Suite 300  
 Raleigh, NC 27606  
 Tel. 919.851.6866  
 Fax. 919.851.7024  
 www.stantec.com  
 License No. F-0672

DocuSigned by  
*J.W. Williams*  
 SEAL  
 19862  
 ENGINEER  
 W. WOOLARD, R.  
 7/24/2024

DIVISION OF HIGHWAYS  
 NORTH CAROLINA  
 DEPARTMENT OF TRANSPORTATION  
 WORK ZONE TRAFFIC CONTROL

-L- NC 150  
 PHASE II  
 STEP 2



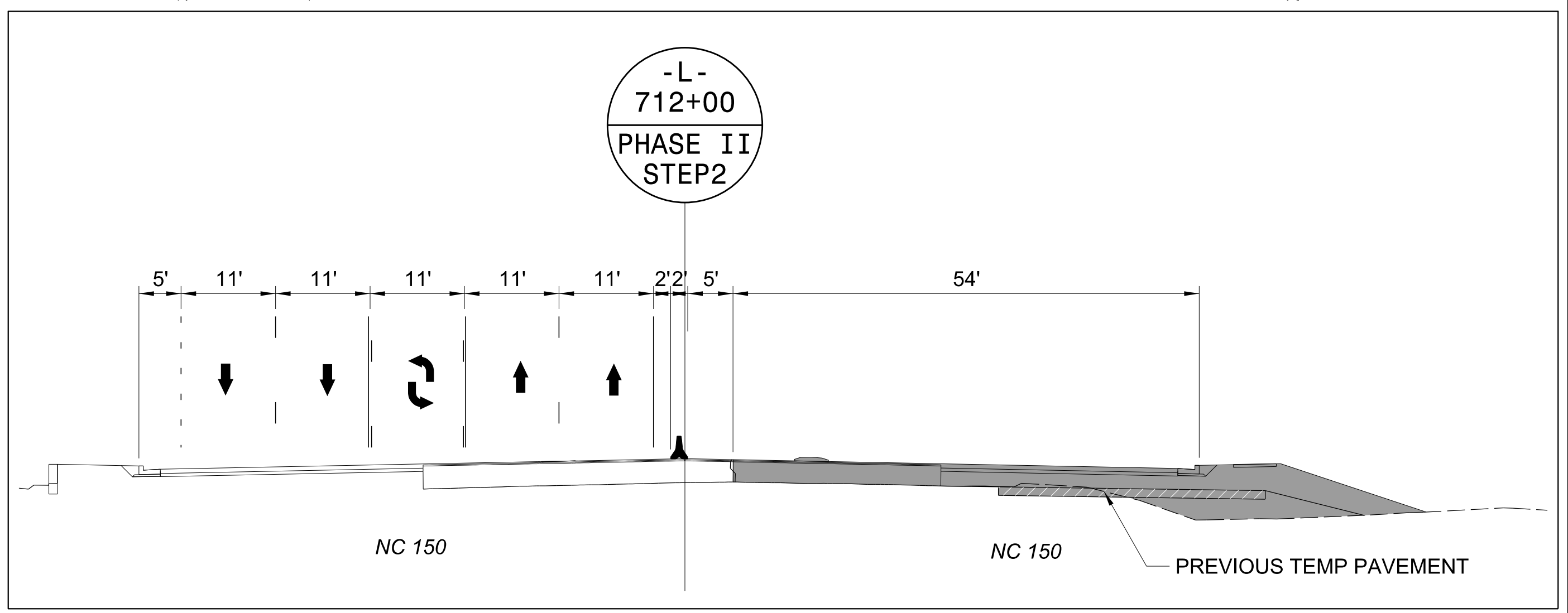
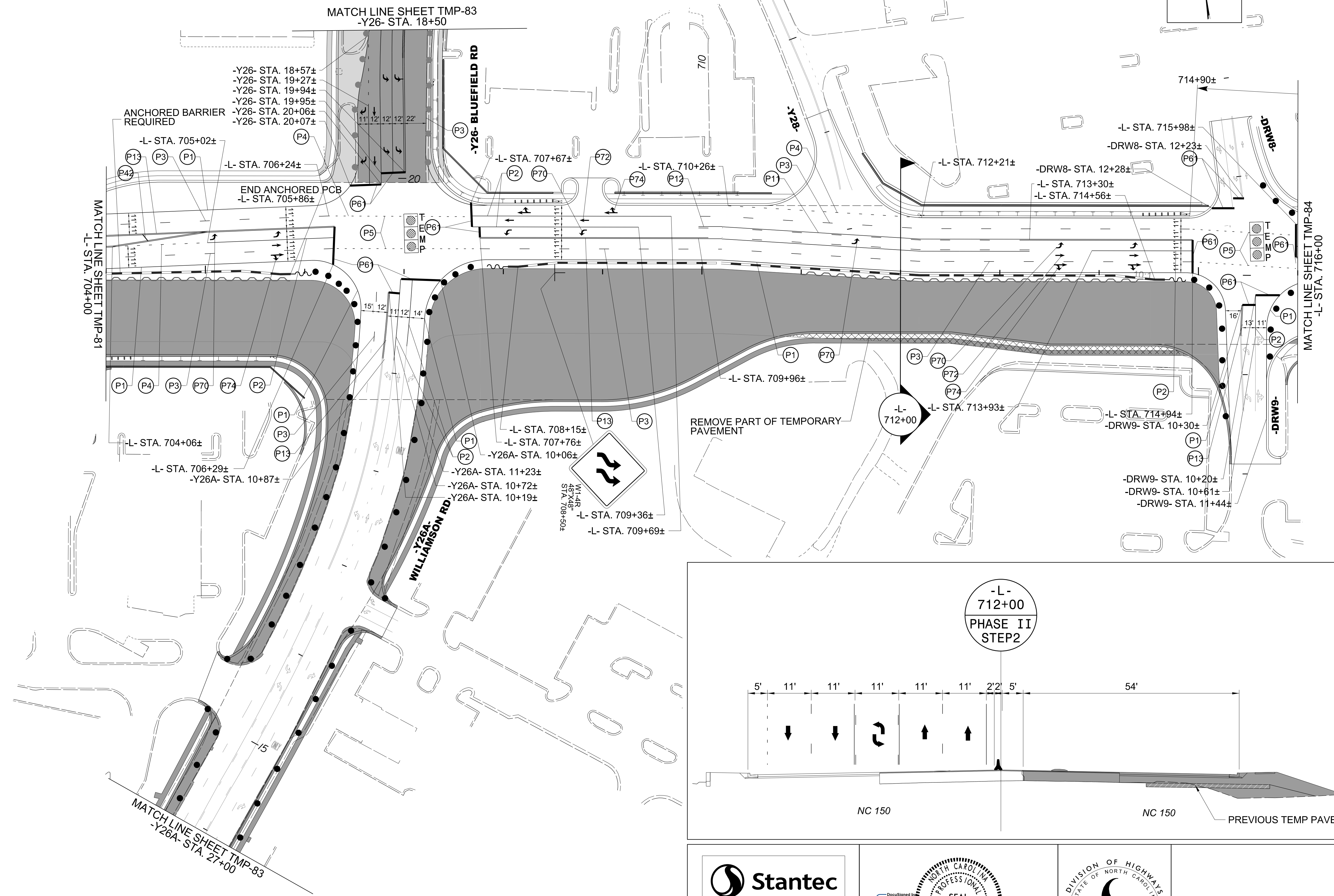

6/4/2024  
 U:\Traffic\Transportation Management\Plan\TCP\PLAN SHEETS\NR-2307B-TMP-82\_PHASE\_02\_STEP\_02.dgn  
 dorichardson

**Stantec**  
 Stantec Consulting Services Inc.  
 801 Jones Franklin Road  
 Suite 300  
 Raleigh, NC 27606  
 Tel. 919.851.6866  
 Fax. 919.851.7024  
 www.stantec.com  
 License No. F-0672

DocuSigned by:  
 J.W. Woolard  
 88C02F48E9D  
 7/24/2024

PROFESSOR'S SEAL  
 19862  
 W. WOOLARD, R.

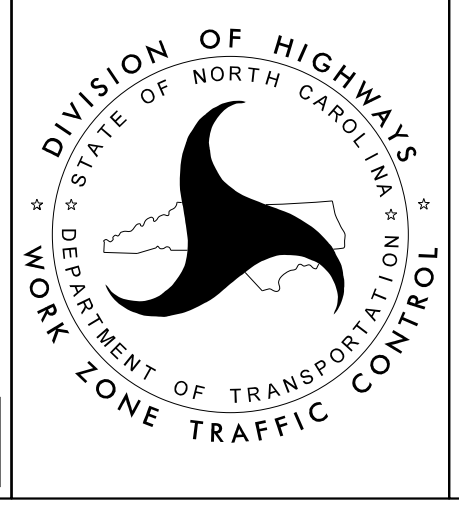

-L- NC 150  
 PHASE II  
 STEP 2

PROJ. REFERENCE NO.	SHEET NO.
R-2307B	TMP-83

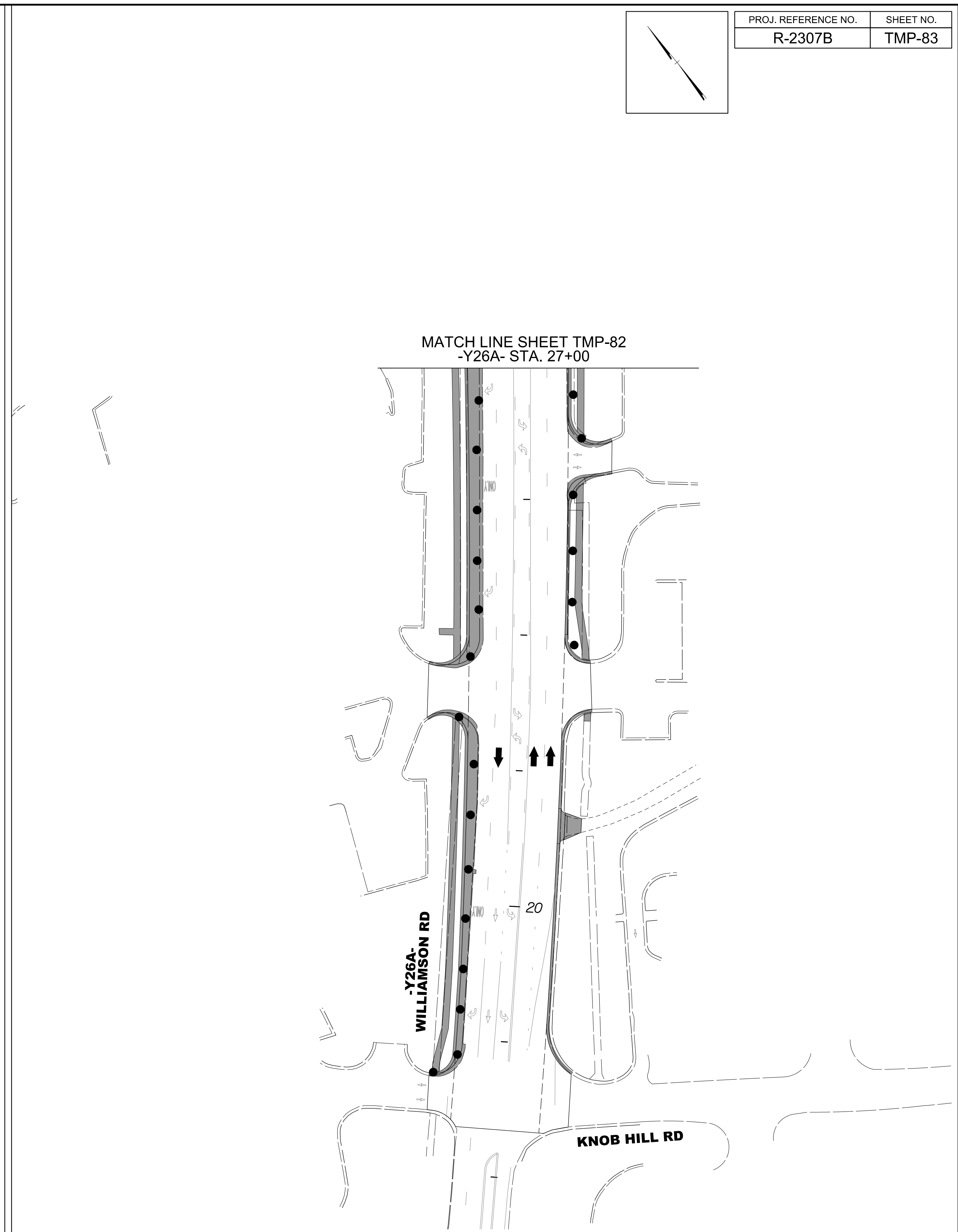
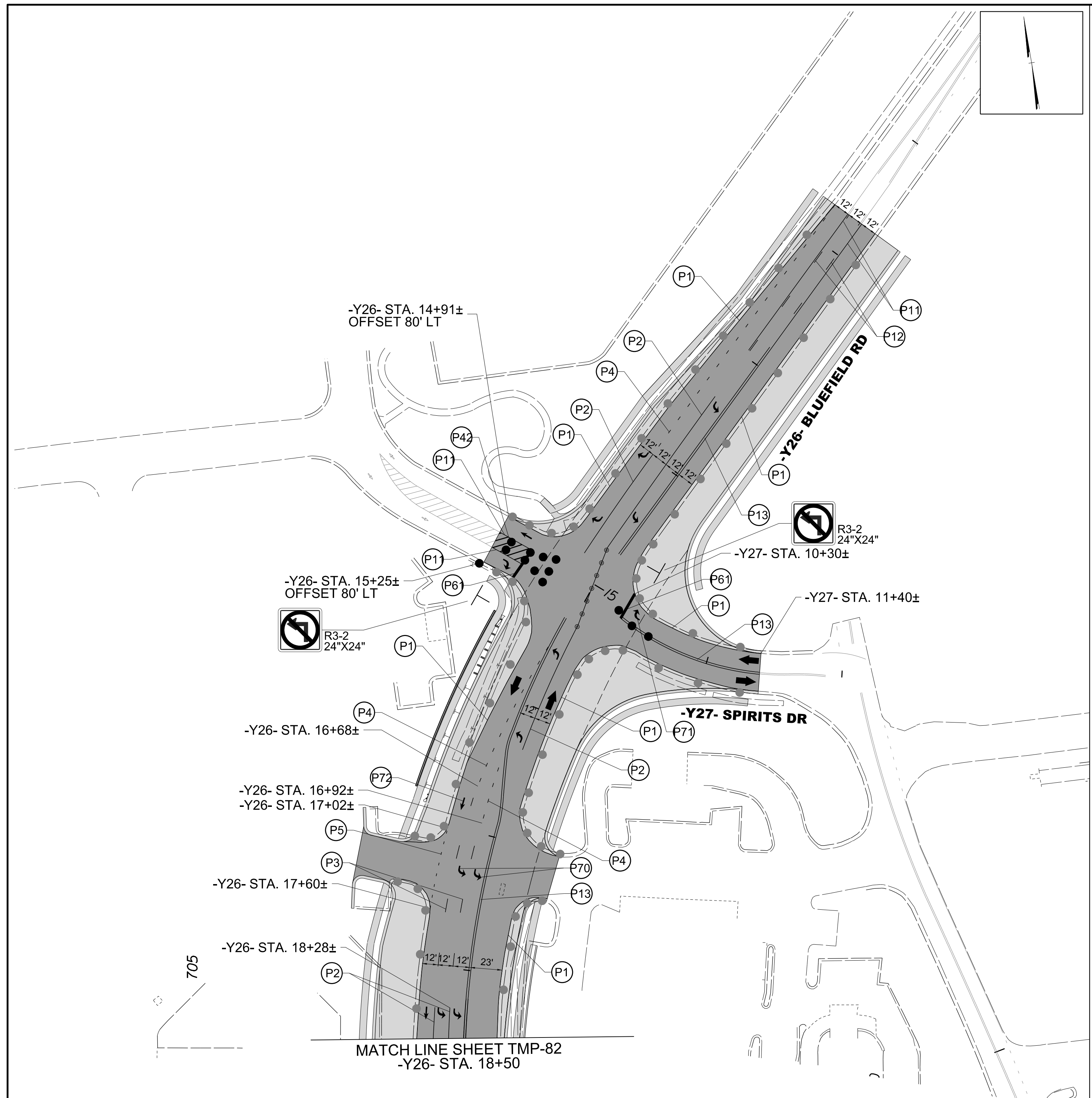

6/4/2024  
 U:\Traffic\Transportation Management\Plan\TCP\PLAN SHEETS\YR-2307B-TMP-83\_PHASE\_02\_STEP\_02.dgn  
 dorichardson

  
 Stantec Consulting Services Inc.  
 801 Jones Franklin Road  
 Suite 300  
 Raleigh, NC 27606  
 Tel. 919.851.6866  
 Fax. 919.851.7024  
 www.stantec.com  
 License No. F-0672

Documented by  
  
 7/24/2024  
**DOCUMENT NOT CONSIDERED FINAL  
 UNLESS ALL SIGNATURES COMPLETED**

DIVISION OF HIGHWAYS  
 DEPARTMENT OF TRANSPORTATION  
 WORK ZONE TRAFFIC CONTROL

-Y26- / -Y26A-  
PHASE II  
STEP 2