

6/23/16

0	2.5	5	PROJ. REFERENCE NO.	SHEET NO.
█	█	█	BR-0097	X-2

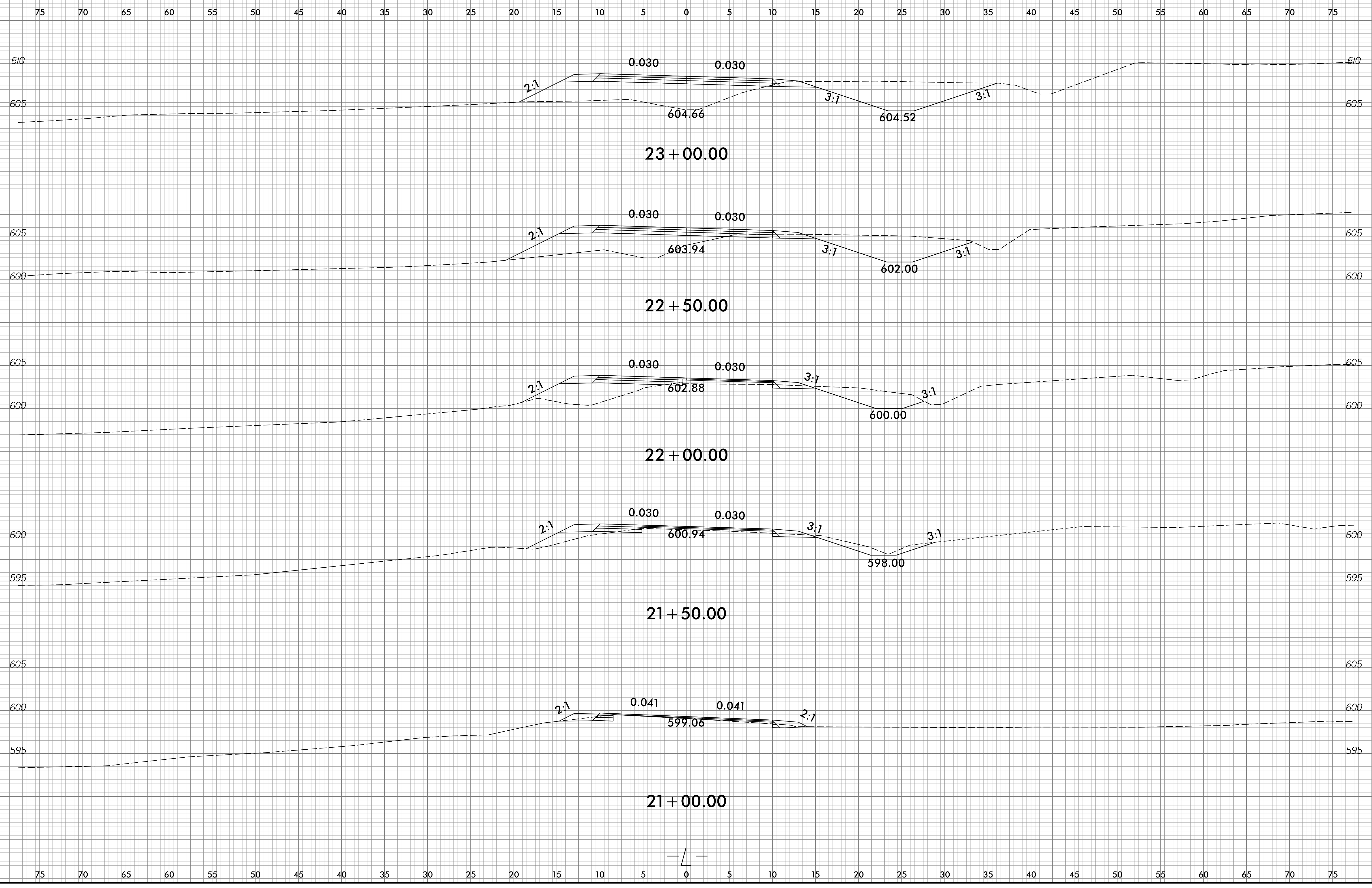

6/7/2024  
c:\p\1001-110\br-0097\roadway\sc\br-0097\_xpl.dgn  
gmodlin

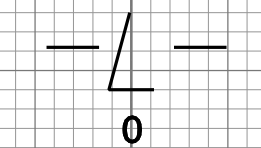

6/23/16

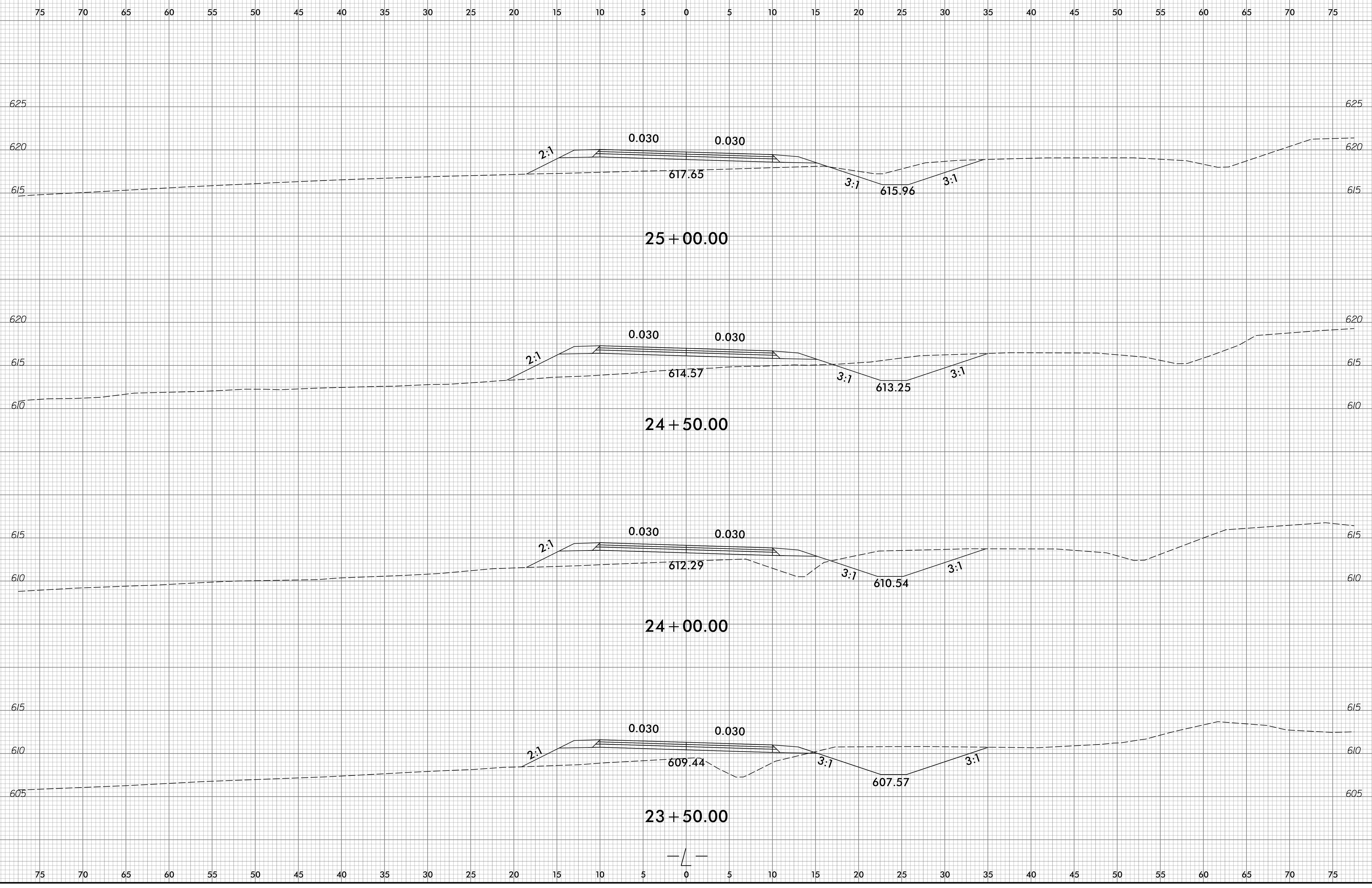

6/7/2024  
c:\p\1001-110\br-0097\roadway\sc\br-0097\_xpl.L.dgn  
gmod11n

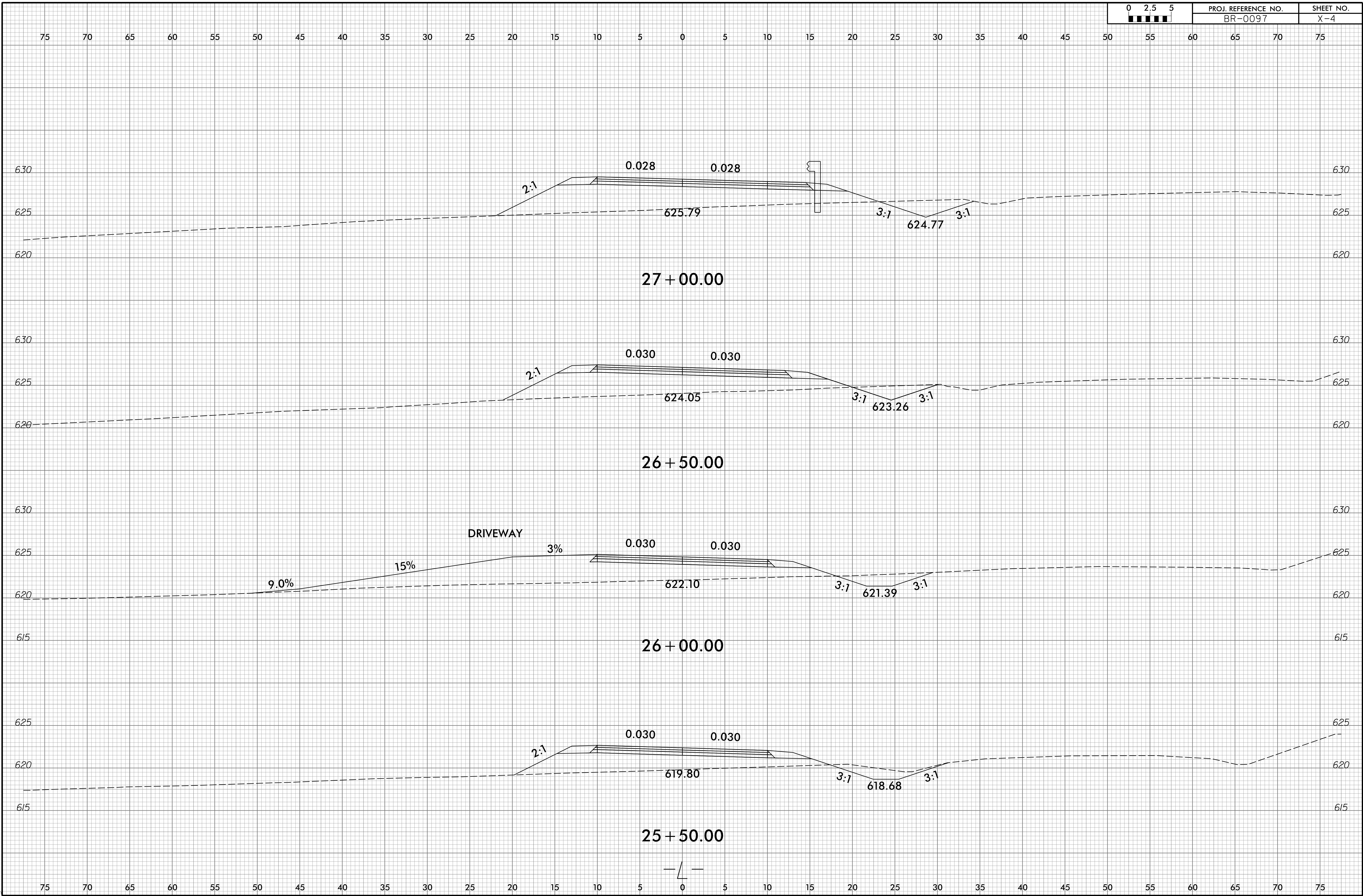



6/23/16

0 2.5 5	PROJ. REFERENCE NO.	SHEET NO.
■■■■■	BR-0097	X-5

75 70 65 60 55 50 45 40 35 30 25 20 15 10 5 0 5 10 15 20 25 30 35 40 45 50 55 60 65 70 75

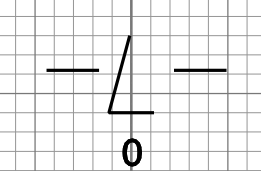
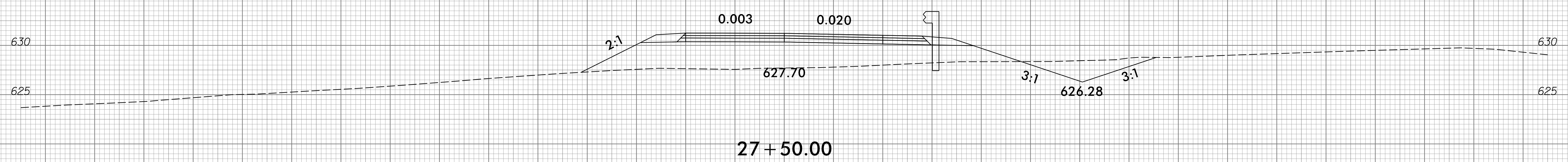
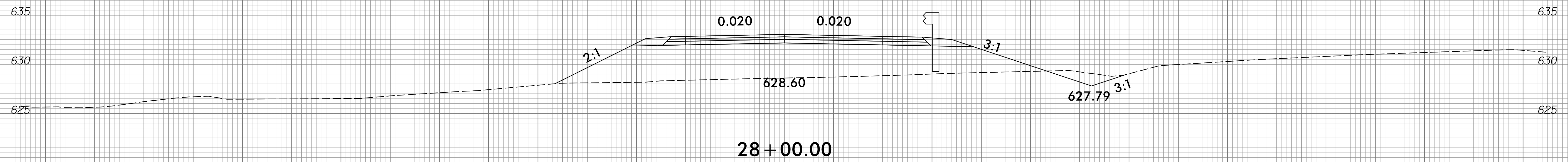
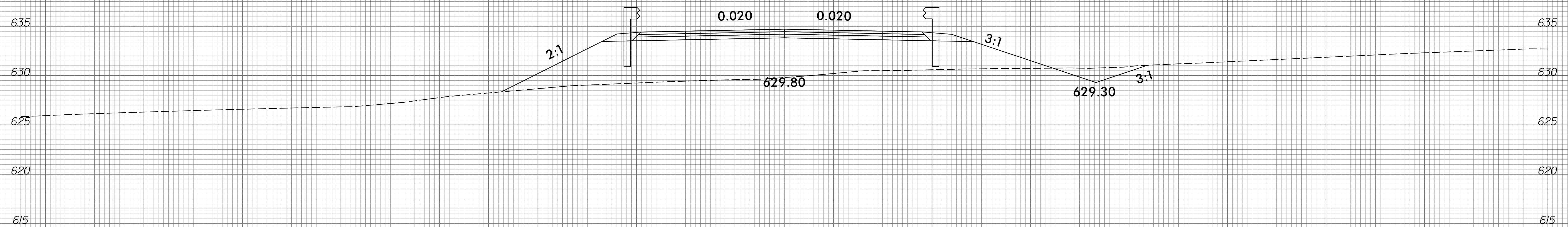

6/7/2024  
 c:\vs\10011-110\br-0097\roadway\sc\br-0097\_xpl.dgn  
 gmodlin

6/23/16

0	2.5	5	PROJ. REFERENCE NO.	SHEET NO.
█	█	█	BR-0097	X-6

75 70 65 60 55 50 45 40 35 30 25 20 15 10 5 0 5 10 15 20 25 30 35 40 45 50 55 60 65 70 75

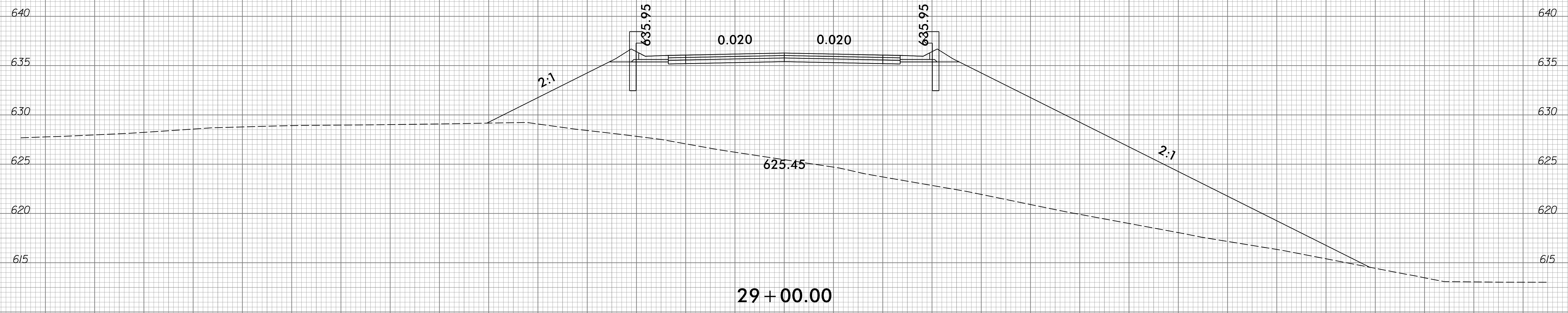
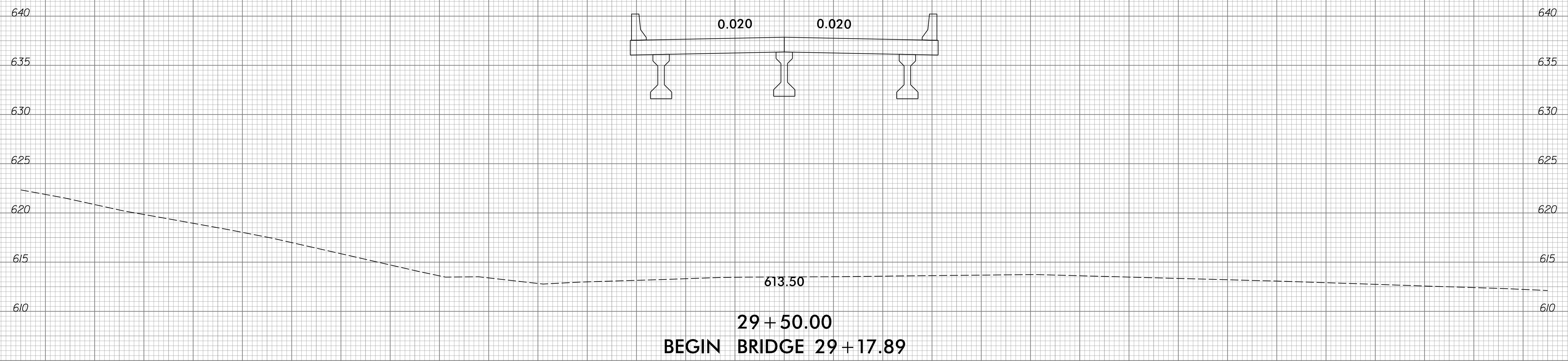

75 70 65 60 55 50 45 40 35 30 25 20 15 10 5 0 5 10 15 20 25 30 35 40 45 50 55 60 65 70 75

6/7/2024  
c:\vs\1001-110\br-0097\roadway\sc-br-0097\_xpl.dgn  
gmodlin

75 70 65 60 55 50 45 40 35 30 25 20 15 10 5 0 5 10 15 20 25 30 35 40 45 50 55 60 65 70 75

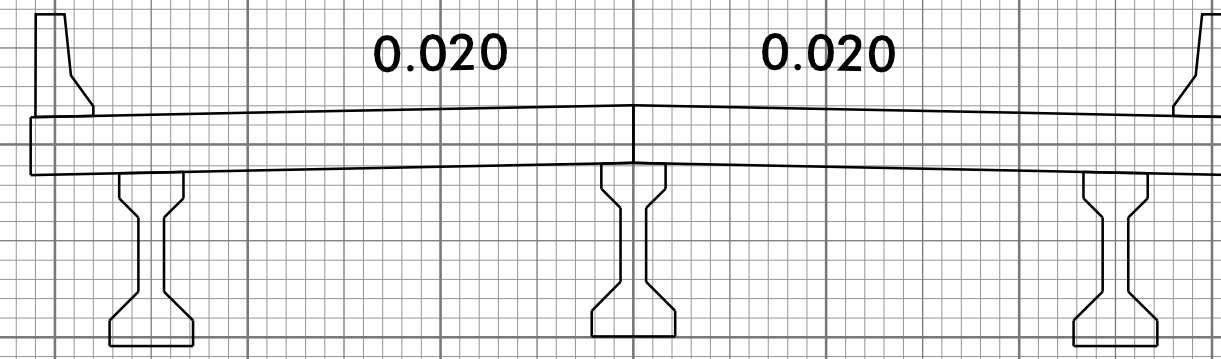

640

640

635

635

630

630

625

625

620

620

615

615

610

610

612.76

30 + 50.00

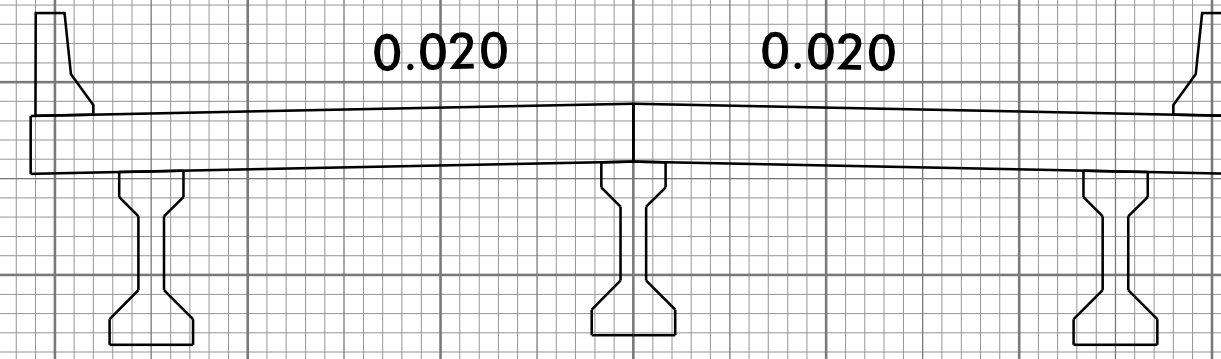

640

640

635

635

630

630

625

625

620

620

615

615

610

610

612.54

30 + 00.00

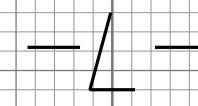

75 70 65 60 55 50 45 40 35 30 25 20 15 10 5 0 5 10 15 20 25 30 35 40 45 50 55 60 65 70 75



6/23/16

0 2.5 5	PROJ. REFERENCE NO.	SHEET NO.
■■■■■	BR-0097	X-8

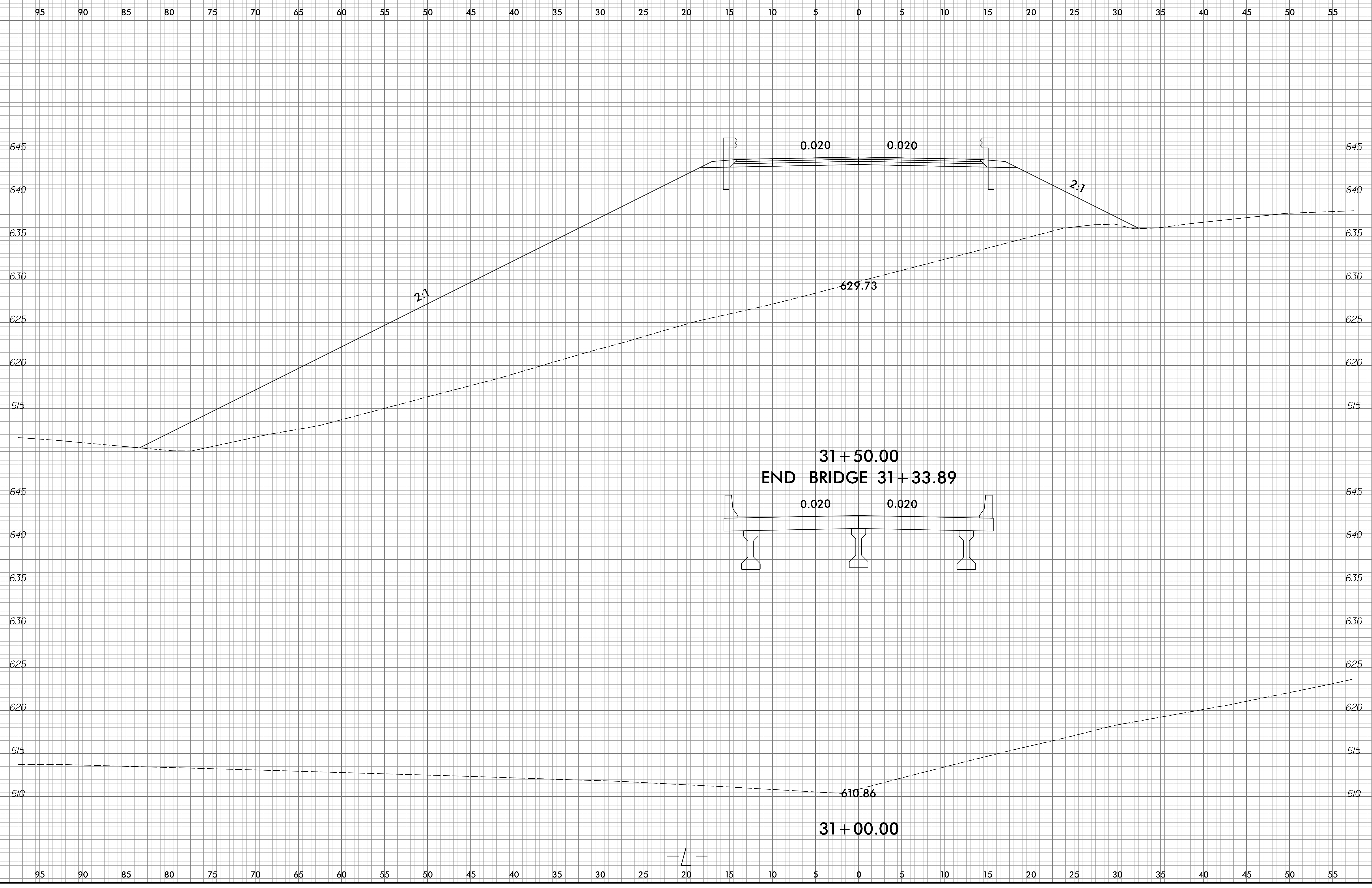

6/7/2024  
c:\p\1001-110\br-0097\roadway\sc\br-0097\_xpl.dgn  
gimod11n

6/23/16

0	2.5	5	PROJ. REFERENCE NO.	SHEET NO.
█	█	█	BR-0097	X-9

75 70 65 60 55 50 45 40 35 30 25 20 15 10 5 0 5 10 15 20 25 30 35 40 45 50 55 60 65 70 75

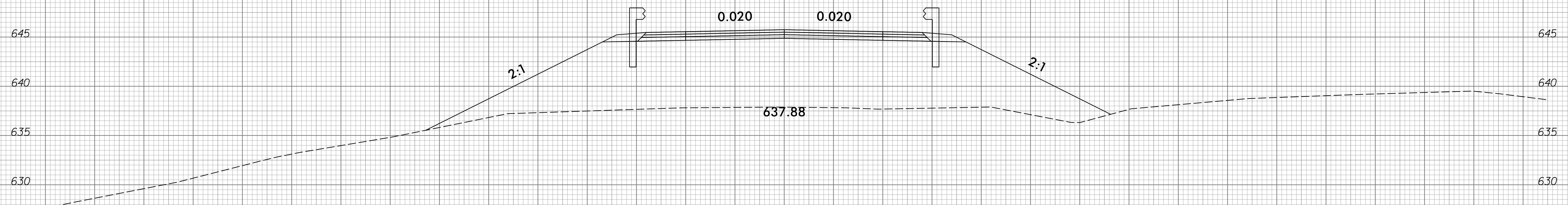
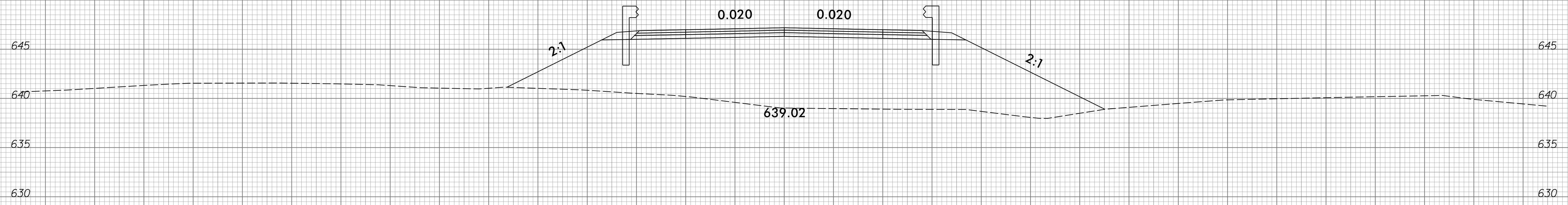

75 70 65 60 55 50 45 40 35 30 25 20 15 10 5 0 5 10 15 20 25 30 35 40 45 50 55 60 65 70 75

6/7/2024  
 c:\p\1001-110\br-0097\roadway\sc\BR-0097\_xpl.dgn  
 gmodlin

6/23/16

0 2.5 5	PROJ. REFERENCE NO.	SHEET NO.
■■■■■	BR-0097	X-10

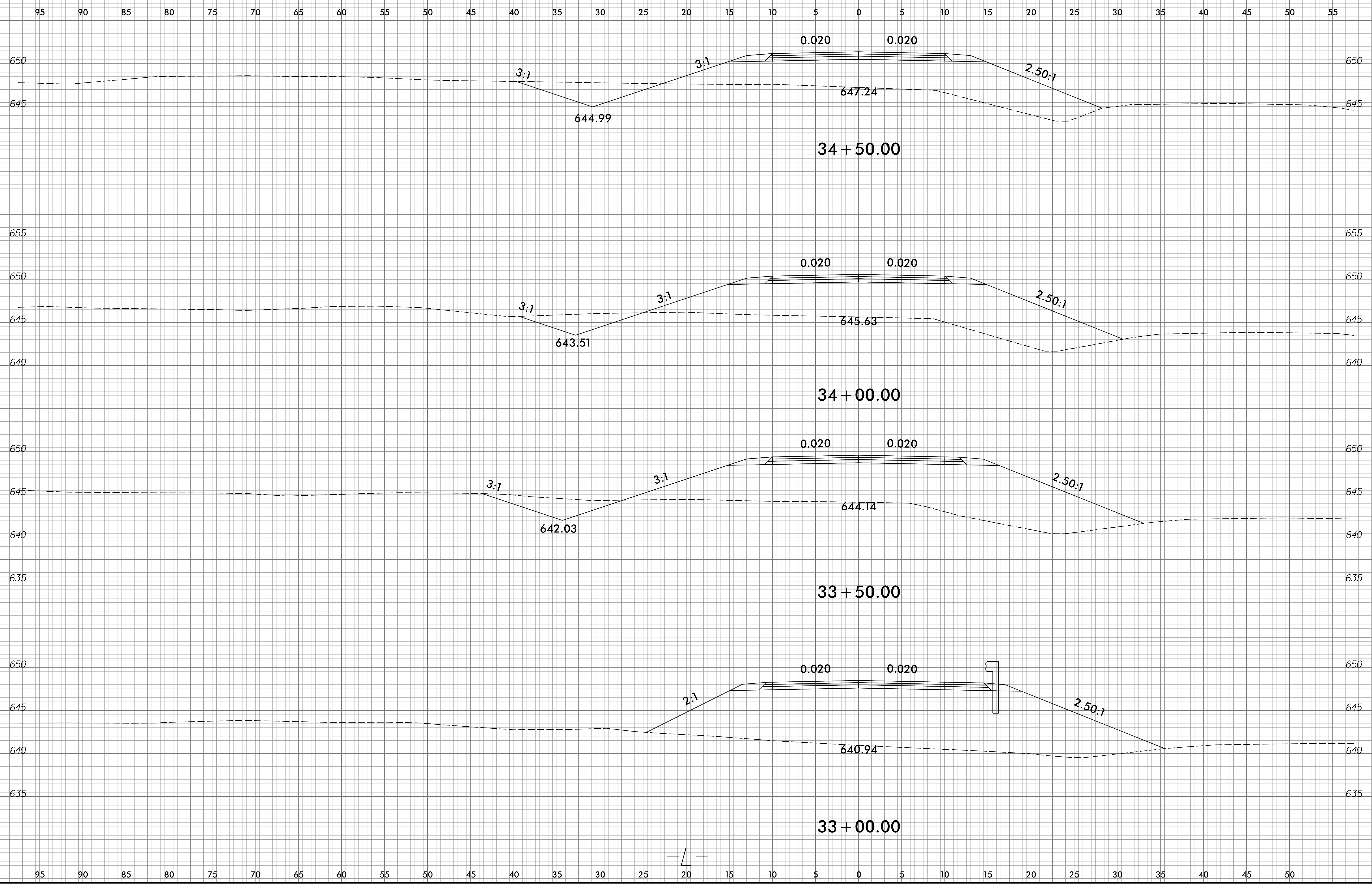

6/7/2024  
c:\vs\10011-110\br-0097\roadway\sc\br-0097\_xpl.dgn  
gimod11n

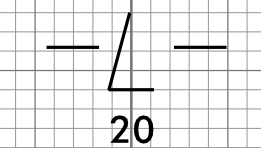

6/23/16

0 2.5 5	PROJ. REFERENCE NO.	SHEET NO.
■■■■■	BR-0097	X-11

75 70 65 60 55 50 45 40 35 30 25 20 15 10 5 0 5 10 15 20 25 30 35 40 45 50 55 60 65 70 75

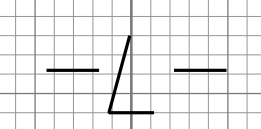
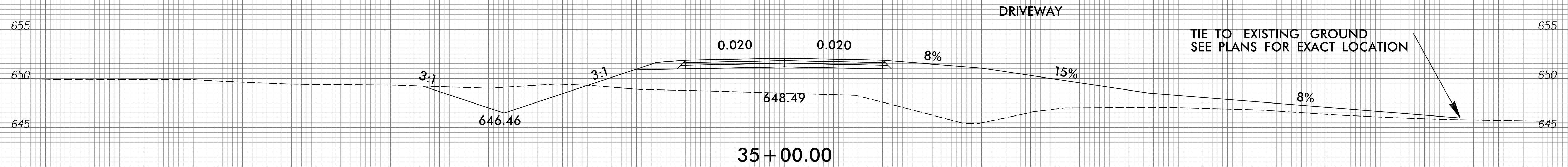
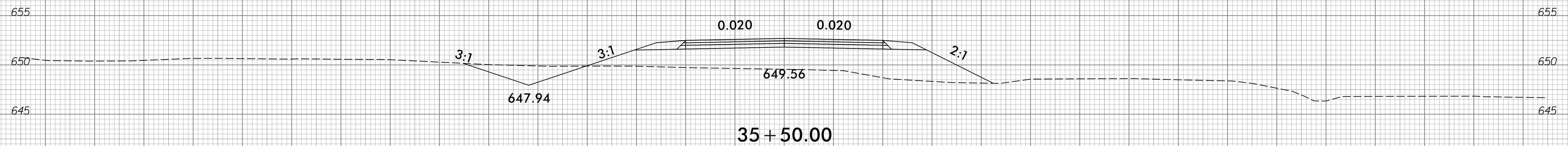
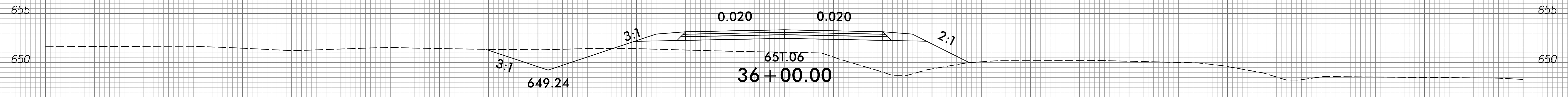
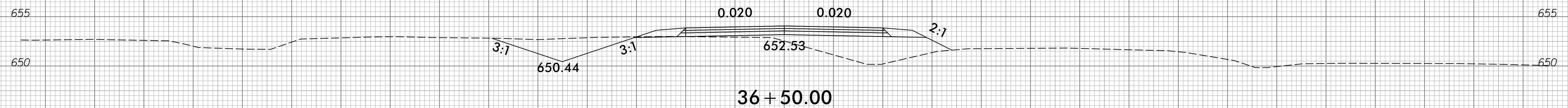
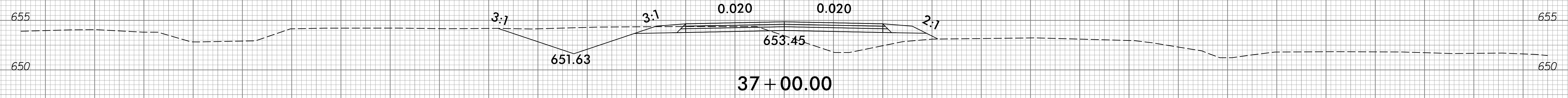

6/7/2024  
c:\p\1001-110\br-0097\roadway\sc\br-0097\_xpl.dgn  
gmodlin

75 70 65 60 55 50 45 40 35 30 25 20 15 10 5 0 5 10 15 20 25 30 35 40 45 50 55 60 65 70 75



6/23/16

0 2.5 5	PROJ. REFERENCE NO.	SHEET NO.
■■■■■	BR-0097	X-12

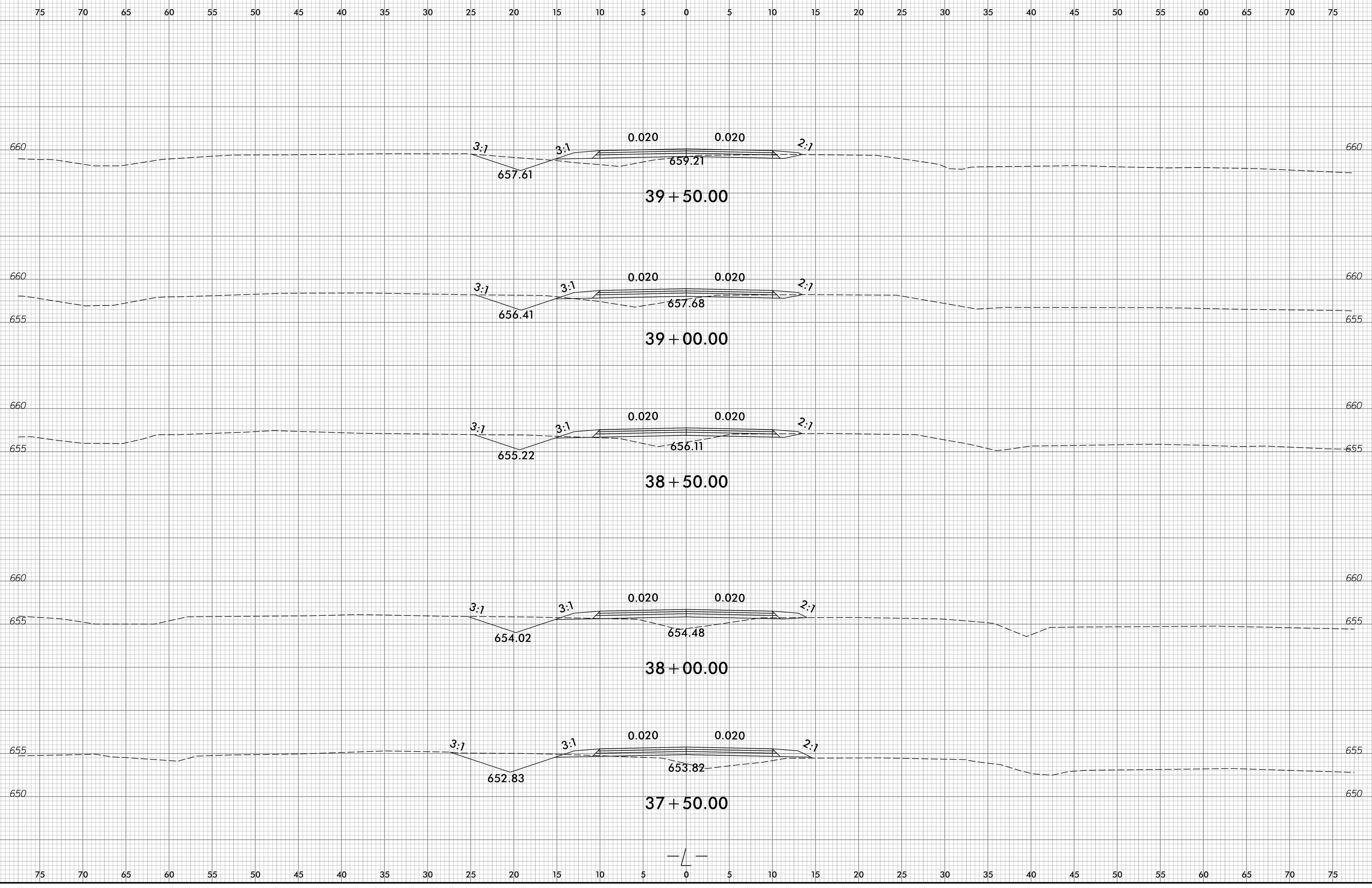

6/7/2024  
c:\p\1001-110\br-0097\roadway\sc\br-0097\_xpl.dgn  
gmodlin

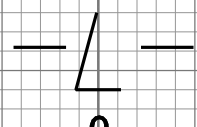



6/23/16

0	2.5	5	PROJ. REFERENCE NO.	SHEET NO.
█	█	█	BR-0097	X-13

75 70 65 60 55 50 45 40 35 30 25 20 15 10 5 0 5 10 15 20 25 30 35 40 45 50 55 60 65 70 75

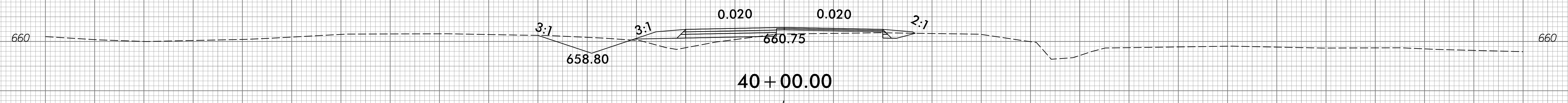
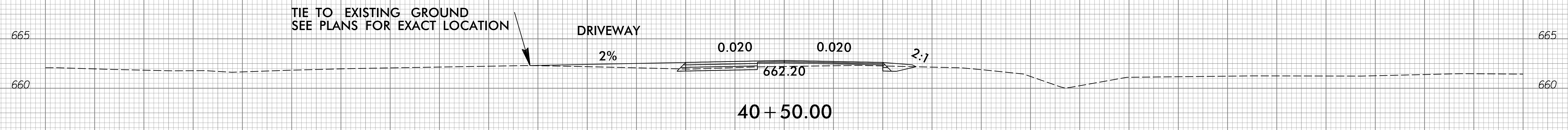
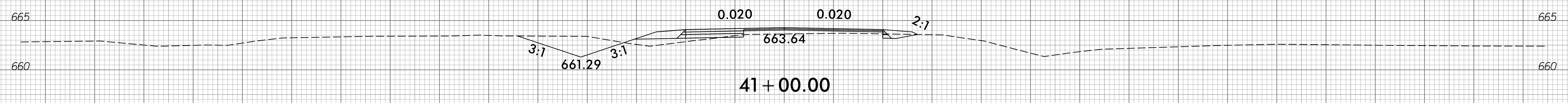
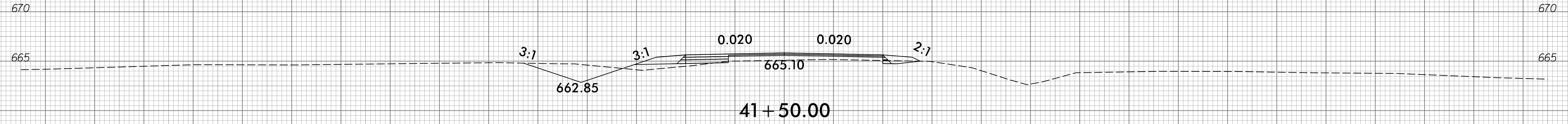
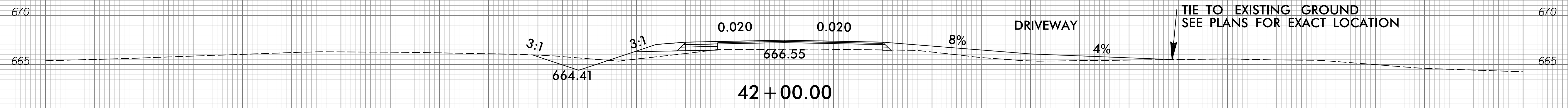

75 70 65 60 55 50 45 40 35 30 25 20 15 10 5 0 5 10 15 20 25 30 35 40 45 50 55 60 65 70 75

6/7/2024  
c:\p\1001-110\br-0097\roadway\sc\br-0097\_xpl.L.dgn  
gmod11n

6/23/16

0 2.5 5	PROJ. REFERENCE NO.	SHEET NO.
■■■■■	BR-0097	X-14

75 70 65 60 55 50 45 40 35 30 25 20 15 10 5 0 5 10 15 20 25 30 35 40 45 50 55 60 65 70 75

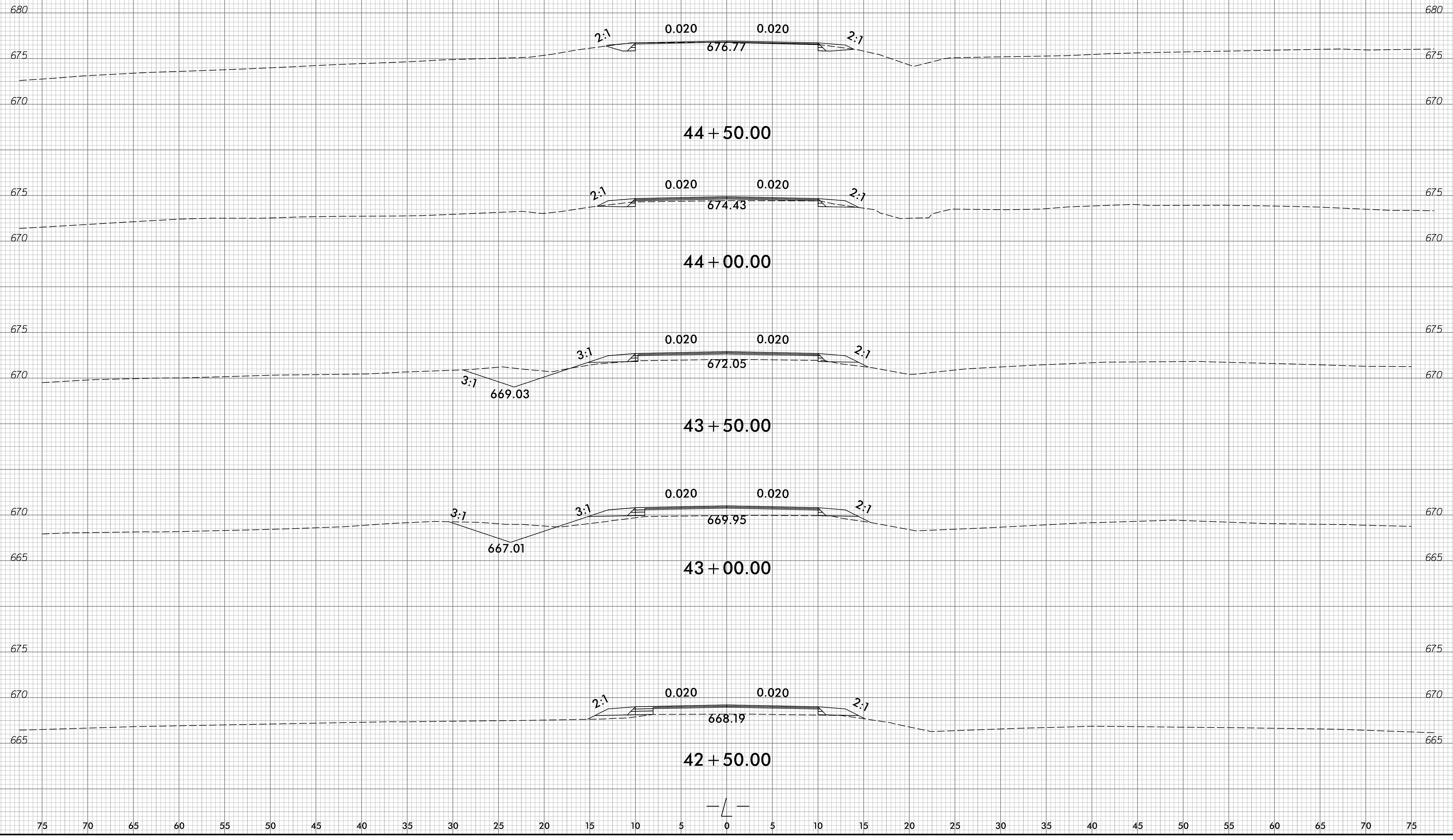

6/7/2024  
 c:\p\1001-110\br-0097\roadway\sc\br-0097\_xpl.dgn  
 gmodlin

75 70 65 60 55 50 45 40 35 30 25 20 15 10 5 0 5 10 15 20 25 30 35 40 45 50 55 60 65 70 75

6/23/16

0	2.5	5	PROJ. REFERENCE NO.	SHEET NO.
█	█	█	BR-0097	X-15

75 70 65 60 55 50 45 40 35 30 25 20 15 10 5 0 5 10 15 20 25 30 35 40 45 50 55 60 65 70 75

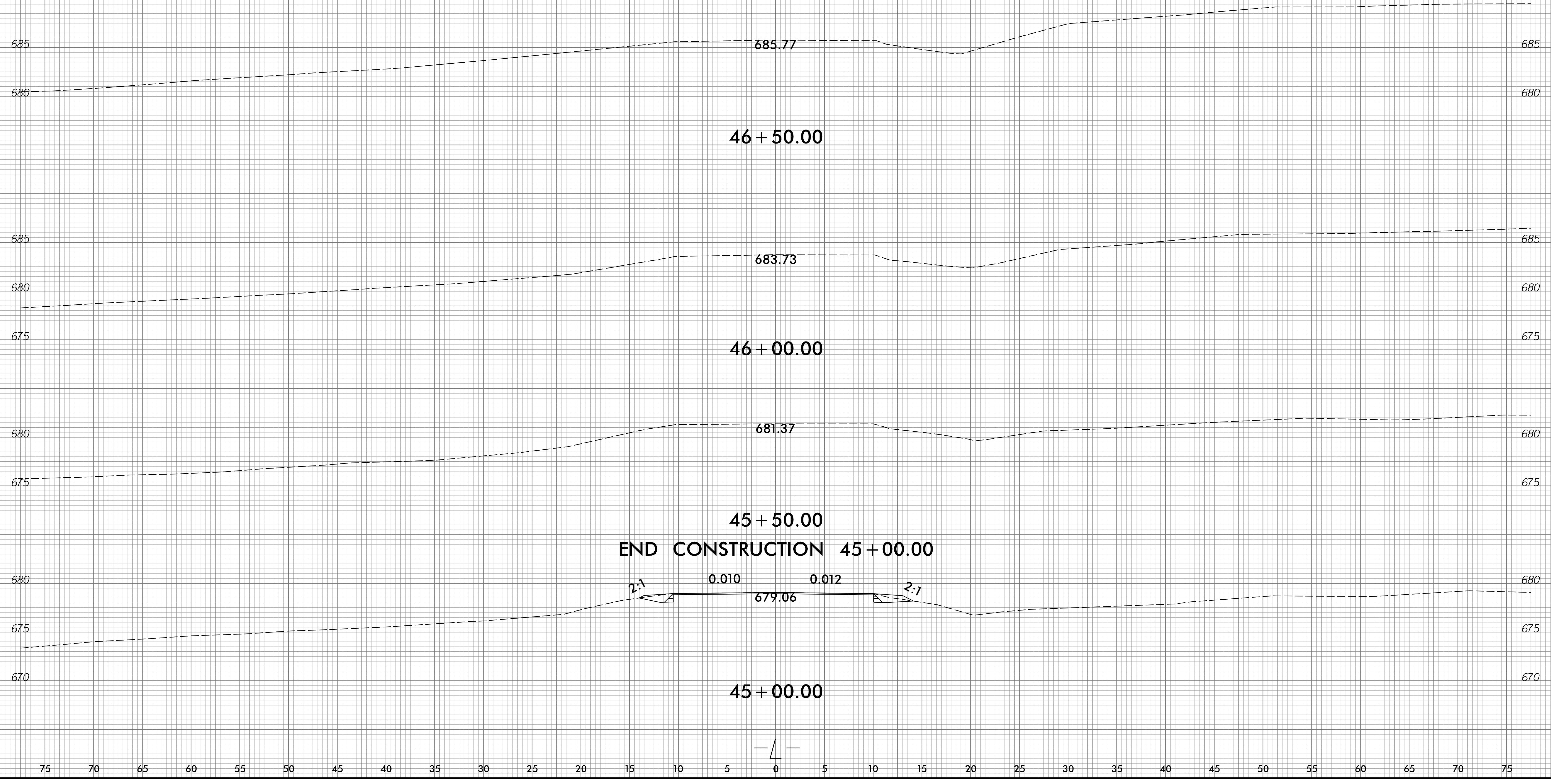

6/7/2024  
 c:\p\1001-110\br-0097\roadway\sc\br-0097\_xpl.dgn  
 gmodlin