

8/17/99

6/17/2024  
 c:\r-a\10011-110\br-0097\tr-offic\pmp\BR-0097\_pmp\_pmp-01.dgn  
 amodlin



**PROJECT: BR-0097**

**CONTRACT: C204864**

STATE OF NORTH CAROLINA  
 DEPARTMENT OF TRANSPORTATION

**PAVEMENT MARKING PLANS**  
**ROCKINGHAM COUNTY**

**LOCATION: BRIDGE NO. 780178 ON SR 1929 (ESTES RD) OVER US 29**

PROJECT REFERENCE NO. BR-0097	SHEET NO. PMP-1
APPROVED: _____	
DATE: _____	
SEAL  6/17/2024	
 <b>moffatt &amp; nichol</b> 4700 FALLS OF NEUSE ROAD, SUITE 300 RALEIGH, NORTH CAROLINA 27609 (919) 781-4626 VOICE (919) 781-4869 FAX (F-0105)	
DOCUMENT NOT CONSIDERED FINAL UNLESS ALL SIGNATURES COMPLETED	

**ROADWAY STANDARD DRAWINGS**

THE FOLLOWING ROADWAY STANDARDS AS SHOWN IN "ROADWAY STANDARD DRAWINGS" - PROJECT SERVICES UNIT - N.C. DEPARTMENT OF TRANSPORTATION - RALEIGH, N.C., DATED JANUARY 2024 ARE APPLICABLE TO THIS PROJECT AND BY REFERENCE HEREBY ARE CONSIDERED A PART OF THESE PLANS:

STD. NO.	TITLE
1205.01	PAVEMENT MARKINGS - LINE TYPES AND OFFSETS
1205.02	PAVEMENT MARKINGS - TWO-LANE AND MULTI-LANE ROADWAYS
1205.12	PAVEMENT MARKINGS - BRIDGES
1250.01	RAISED PAVEMENT MARKERS - INSTALLATION SPACING
1251.01	RAISED PAVEMENT MARKERS - PERMANENT AND TEMPORARY
1261.01	GUARDRAIL AND BARRIER DELINEATORS - INSTALLATION SPACING
1261.02	GUARDRAIL AND BARRIER DELINEATORS - TYPES AND MOUNTING
1262.01	GUARDRAIL END DELINEATION

**GENERAL NOTES**

THE FOLLOWING GENERAL NOTES APPLY AT ALL TIMES FOR THE DURATION OF THE CONSTRUCTION PROJECT, EXCEPT WHEN OTHERWISE NOTED IN THE PLAN, OR DIRECTED BY THE ENGINEER.

- A) INSTALL PAVEMENT MARKINGS AND PAVEMENT MARKERS ON THE FINAL SURFACE AS FOLLOWS:
- | ROAD NAME        | MARKING              | MARKER                     |
|------------------|----------------------|----------------------------|
| -L- (SR 1929)    | THERMOPLASTIC        | SNOWFLOWABLE NON CAST IRON |
| ALL BRIDGE DECKS | COLD APPLIED PLASTIC | PERMANENT RAISED           |
- B) TIE PROPOSED PAVEMENT MARKING LINES TO EXISTING PAVEMENT MARKING LINES.
- C) REMOVE / REPLACE ANY CONFLICTING / DAMAGED PAVEMENT MARKINGS AND MARKERS.
- D) PASSING ZONES WILL BE DETERMINED IN THE FIELD AND MUST BE APPROVED BY THE ENGINEER.
- E) REMOVE ALL RESIDUE AND SURFACE LAITANCE BY ACCEPTABLE METHODS ON CONCRETE BRIDGE DECKS PRIOR TO PLACING COLD APPLIED PLASTIC PAVEMENT MARKING MATERIAL.

**INDEX**

SHEET NO.	DESCRIPTION
PMP-1	PAVEMENT MARKING PLAN TITLE, LIST OF STANDARD DRAWINGS, GENERAL NOTES AND INDEX OF SHEETS
PMP-2	FINAL PAVEMENT MARKING SCHEDULE AND LEGEND
PMP-3 THRU PMP-5	PAVEMENT MARKING DETAILS

**PLAN REVIEWED BY: NCDOT SIGNING AND DELINEATION UNIT**

_____ KELVIN JORDAN	SIGNING & DELINEATION REGIONAL ENGINEER
_____ J.NAVARRETE	SIGNING & DELINEATION PROJECT DESIGN ENGINEER

**PLAN PREPARED BY: MOFFATT & NICHOL**

_____ TRENT HUFFMAN, PE	PROJECT ENGINEER
_____ ZITONG LIU, EI	PROJECT DESIGN

**FINAL PAVEMENT MARKING SCHEDULE**

MATERIAL	SYMBOL	DESCRIPTION
<u>COLD APPLIED PLASTIC, TYPE I (4")</u>		
	C1	WHITE EDGE LINE
	C13	YELLOW DOUBLE CENTER
<u>THERMOPLASTIC (4", 90 MILS)</u>		
	T1	WHITE EDGE LINE
	T13	YELLOW DOUBLE CENTER
<u>PAVEMENT MARKER SYMBOLS</u>		
	MA	PERMANENT RAISED YELLOW & YELLOW
	ME	SNOWPLOWABLE MARKER YELLOW & YELLOW

**LEGEND**

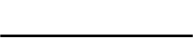
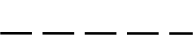
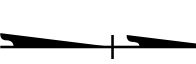
- GENERAL**
-  PROPOSED PAVEMENT
  -  EXISTING PAVEMENT
  -  NORTH ARROW

1/18/2024  
 O:\RA\1001-110\BR-0097\Trafic\PMP\BR-0097\_pmp\_pmp-02.dgn  
 gmc:lin



APPROVED: *Trent E. Huffman*

DATE: 1/19/2024

SEAL



**DOCUMENT NOT CONSIDERED FINAL  
UNLESS ALL SIGNATURES COMPLETED**



**FINAL PAVEMENT  
MARKING SCHEDULE  
AND LEGEND**

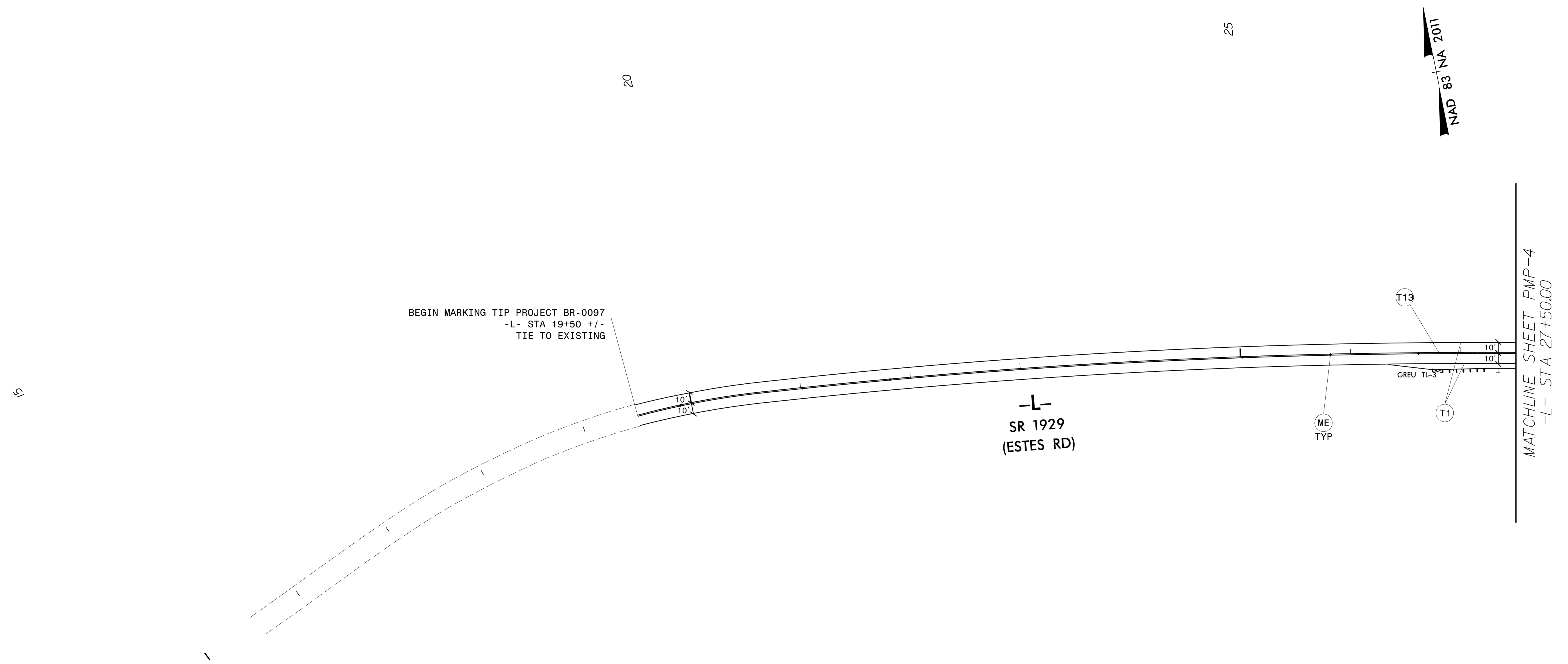

1/19/2024  
 g:\p\2024\001\10\BR-0097\Traffic\PMMP\BR-0097.pmp.pmp-03.dgn  
 smodin

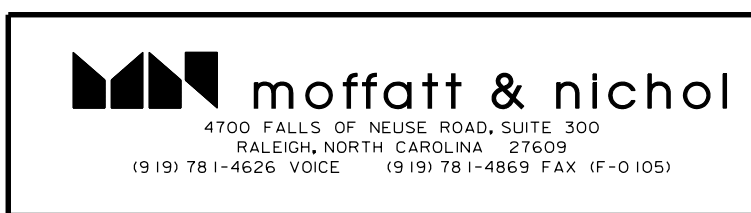

APPROVED: *Trist E. Huffman*  
85008770170489

DATE: 1/19/2024

SEAL

**DOCUMENT NOT CONSIDERED FINAL  
UNLESS ALL SIGNATURES COMPLETED**

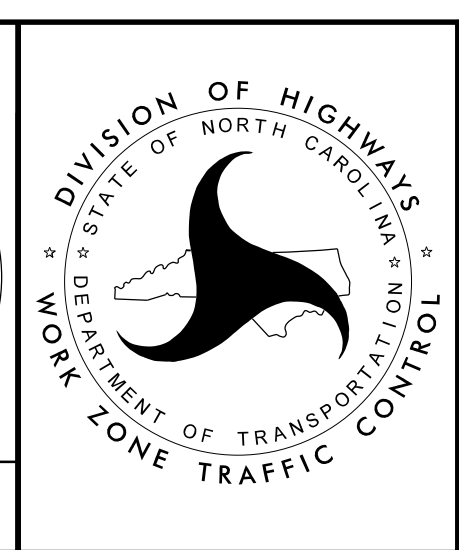

FINAL PAVEMENT  
MARKING PLANS

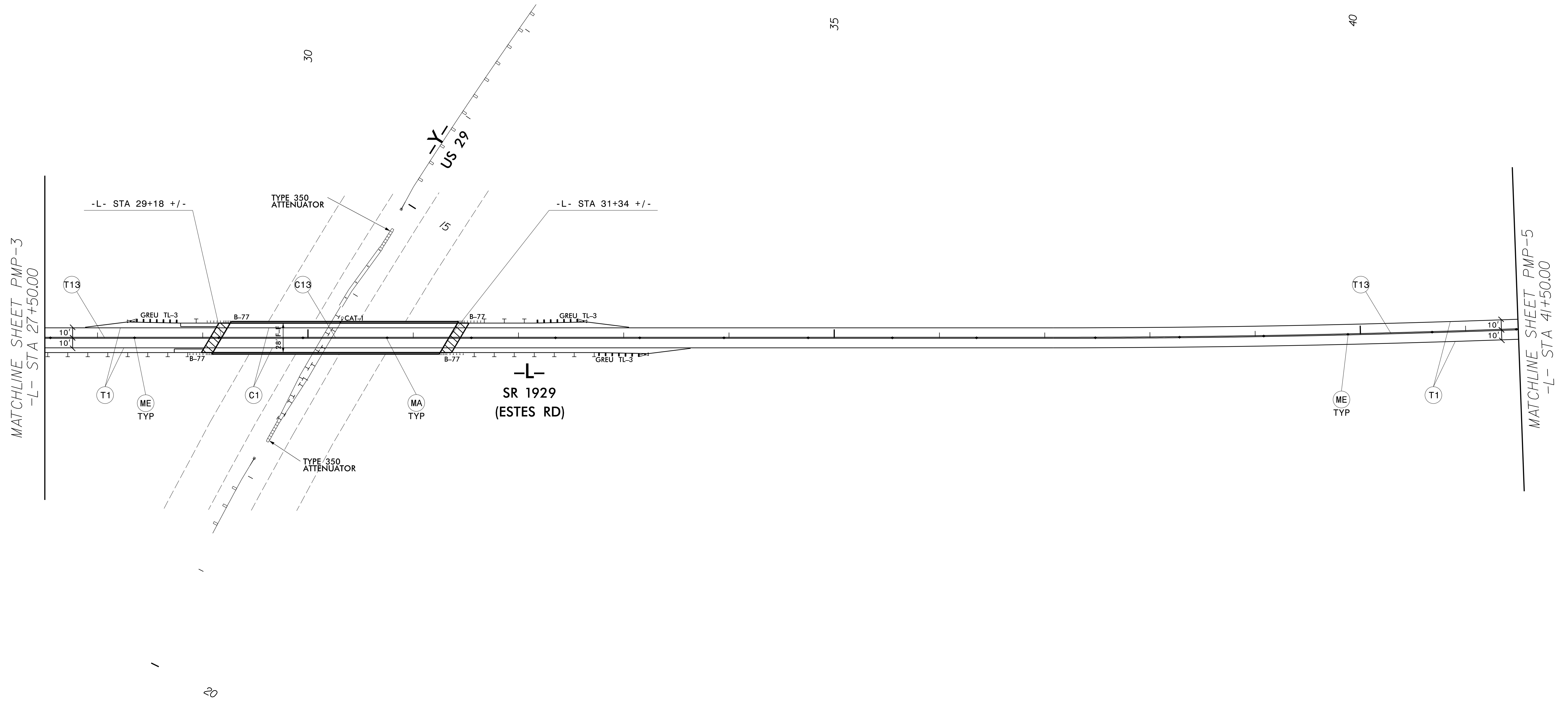
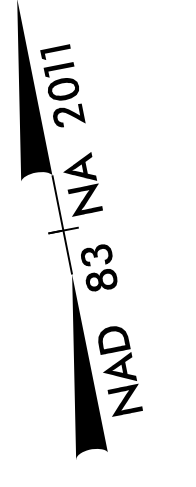

1/19/2024  
 g:\p\001\10\BR-0097\Traffic\pmp\BR-0097.pmp.pmp-04.dgn  
 smodin

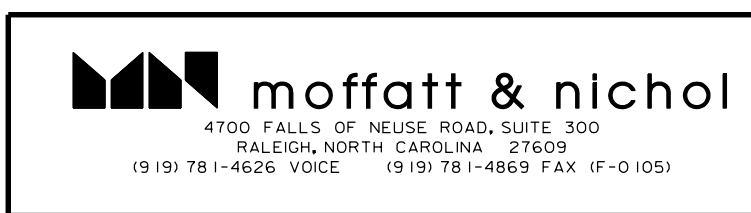

APPROVED: Trent E. Huffman  
DESIGNED BY: 550049770170219

DATE: 1/19/2024

SEAL

**DOCUMENT NOT CONSIDERED FINAL  
UNLESS ALL SIGNATURES COMPLETED**

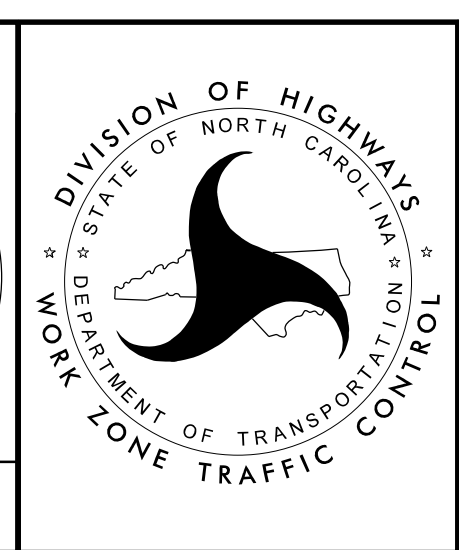

**FINAL PAVEMENT  
MARKING PLANS**

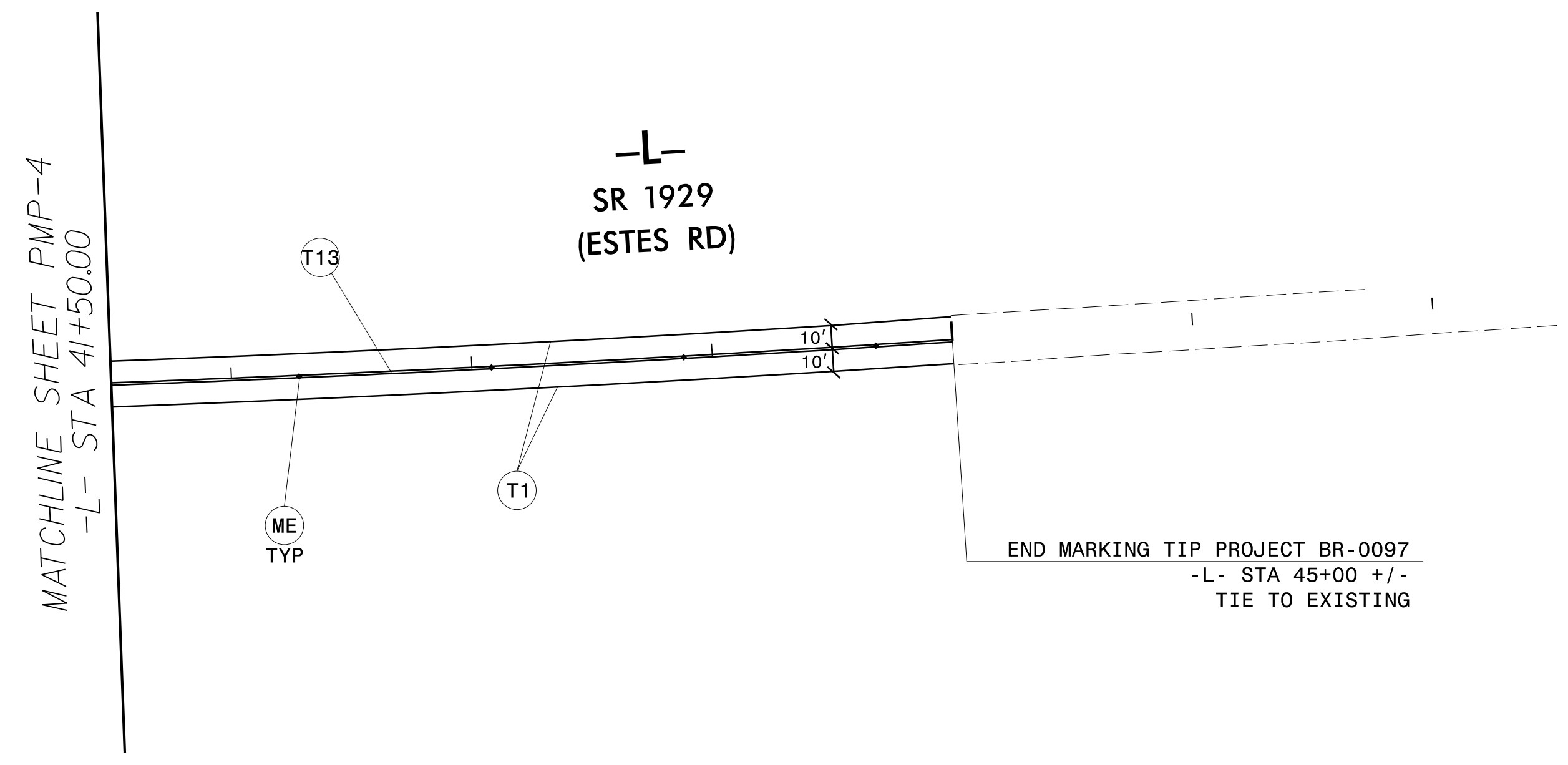
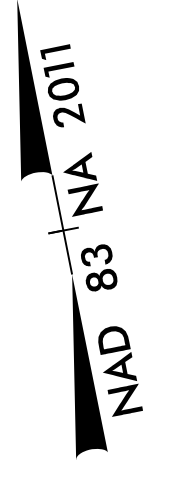

45

50

1/19/2024  
 g:\p\2024\001\10\BR-0097\Traffic\PM\BR-0097.pmp.pmp-05.dgn  
 smodm

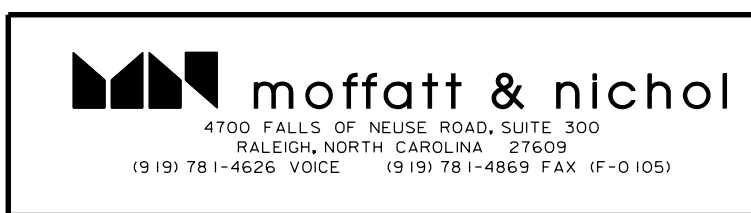

APPROVED: Trent E. Huffman  
550049770170219

DATE: 1/19/2024

SEAL

**SEAL**  
 023912  
 PROFESSIONAL ENGINEER  
 TRENT E. HUFFMAN

**DOCUMENT NOT CONSIDERED FINAL  
 UNLESS ALL SIGNATURES COMPLETED**

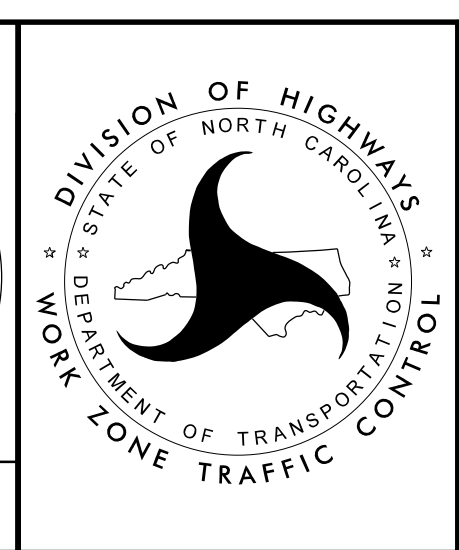

**FINAL PAVEMENT  
 MARKING PLANS**