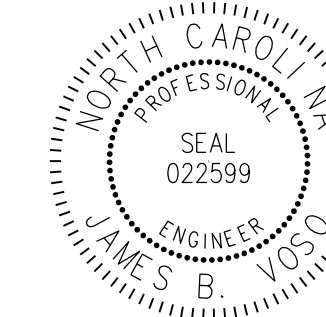

TIP: U-5783

CONTRACT: 44354.3.1

STATE OF NORTH CAROLINA
DEPARTMENT OF TRANSPORTATION

PAVEMENT MARKING PLANS
HENDERSON COUNTY

PROJECT REFERENCE NO. U-5783	SHEET NO. PMP-1
APPROVED:  140FD00376E041F	
DATE: 4/1/2024	
SEAL 	
DOCUMENT NOT CONSIDERED FINAL UNLESS ALL SIGNATURES COMPLETED	

ROADWAY STANDARD DRAWING

THE FOLLOWING ROADWAY STANDARDS AS APPEAR IN "ROADWAY STANDARD DRAWINGS" - PROJECT SERVICES UNIT - N.C. DEPARTMENT OF TRANSPORTATION - RALEIGH, N.C., DATED JANUARY 2024 ARE APPLICABLE TO THIS PROJECT AND BY REFERENCE HEREBY ARE CONSIDERED A PART OF THESE PLANS:

STD. NO.	TITLE
1205.01	PAVEMENT MARKINGS - LINE TYPES AND OFFSETS
1205.02	PAVEMENT MARKINGS - TWO-LANE AND MULTILANE ROADWAYS
1205.04	PAVEMENT MARKINGS - INTERSECTIONS
1205.05	PAVEMENT MARKINGS - TURN LANES
1205.07	PAVEMENT MARKINGS - PEDESTRIAN CROSSWALKS
1205.08	PAVEMENT MARKINGS - SYMBOLS AND WORD MESSAGES
1205.09	PAVEMENT MARKINGS - PAINTED ISLANDS
1205.10	PAVEMENT MARKINGS - SCHOOL AREAS
1205.14	PAVEMENT MARKINGS - ROUNDABOUTS
1205.15	PAVEMENT MARKINGS - REDUCED CONFLICT INTERSECTIONS
1205.16	BICYCLE FACILITIES
1250.01	RAISED PAVEMENT MARKERS
1261.01	GUARDRAIL AND BARRIER DELINEATORS
1261.02	GUARDRAIL AND BARRIER DELINEATORS
1262.01	GUARDRAIL END DELINEATION

GENERAL NOTES

THE FOLLOWING GENERAL NOTES APPLY AT ALL TIMES FOR THE DURATION OF THE CONSTRUCTION PROJECT, EXCEPT WHEN OTHERWISE NOTED IN THE PLAN, OR DIRECTED BY THE ENGINEER.

A) INSTALL PAVEMENT MARKINGS AND PAVEMENT MARKERS ON THE FINAL SURFACE AS FOLLOWS:

ROAD NAME	MARKING	MARKER
-L- US 64 (BREVARD ROAD)	THERMOPLASTIC WITH HIGHLY REFLECTIVE ELEMENTS	SNOWPLOWABLE

B) STATE FORCES WILL INSTALL PAVEMENT MARKINGS AND PAVEMENT MARKERS ON THE FINAL SURFACE AS FOLLOWS:

ROAD NAME	MARKING	MARKER
-Y- ALIGNMENTS	THERMOPLASTIC WITH HIGHLY REFLECTIVE ELEMENTS	SNOWPLOWABLE

C) TIE PROPOSED PAVEMENT MARKING LINES TO EXISTING PAVEMENT MARKING LINES.

D) REMOVE/REPLACE ANY CONFLICTING/DAMAGED PAVEMENT MARKINGS AND MARKERS.

E) STOP BAR LOCATION AT NON-SIGNALIZED INTERSECTIONS MAY BE ADJUSTED AS DIRECTED BY THE ENGINEER.

F) UNLESS OTHERWISE SPECIFIED, HEATED-IN-PLACE THERMOPLASTIC MAY BE USED IN LIEU OF EXTRUDED THERMOPLASTIC FOR STOP BARS, SYMBOLS, CHARACTERS AND DIAGONALS. IF HEATED-IN-PLACE IS USED, IT SHALL BE PAID FOR USING THE EXTRUDED THERMOPLASTIC PAY ITEM.

G) ALL BICYCLE LANE SYMBOLS SHALL BE HEATED-IN-PLACE THERMOPLASTIC. SYMBOLS SHALL BE PAID FOR USING THE HEATED-IN-PLACE PAY ITEM.

INDEX

SHEET NO.	DESCRIPTION
PMP-1	PAVEMENT MARKING PLAN TITLE SHEET
PMP-1A	PAVEMENT MARKING SCHEDULE & LEGEND
PMP-2-2K	PAVEMENT MARKING DETAIL SHEETS

PLAN SUBMITTED TO:

Kenneth McDowell - NCDOT Division 14 Assistant Design Construction Engineer

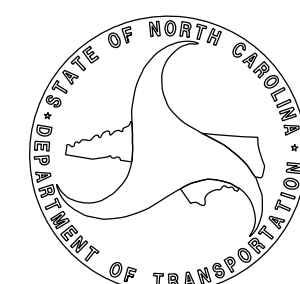

PLAN PREPARED BY: Mattern & Craig

Kyle Eudy Project Design Engineer

James Voso Project Engineer

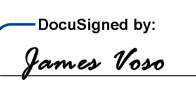
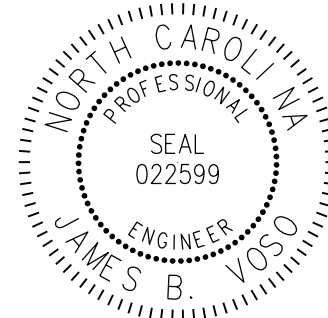

Mattern & Craig
ENGINEERS-SURVEYORS
12 BROAD STREET
ASHEVILLE, NORTH CAROLINA 28801
(828) 254-2201
FAX (828) 254-4562
NC LIC. NO. C-1154

PROJECT REFERENCE NO.	SHEET NO.
U-5783	PMP-1A
APPROVED:  140FD90379E041F	
DATE: 4/1/2024	
SEAL	
	
DOCUMENT NOT CONSIDERED FINAL UNLESS ALL SIGNATURES COMPLETED	

Mattern & Craig
ENGINEERS-SURVEYORS
12 BROAD STREET
ASHEVILLE, NORTH CAROLINA 28801
(828) 254-2201
FAX (828) 254-4562
NC LIC. NO. C-1154

PAVEMENT MARKING SCHEDULE

<u>SYMBOL</u>	<u>MARKINGS</u>
	<u>THERMOPLASTIC</u>
H1	WHITE EDGELINE, HRM (4", 90 MIL)
H2	WHITE SOLID LANE LINE, HRM (4", 90 MIL)
H4	3 FT.-9FT./SP WHITE MINISKIP, HRM (4", 90 MIL)
H5	2 FT.-6FT./SP WHITE MINISKIP, HRM (4", 90 MIL)
H10	YELLOW EDGELINE, HRM (4", 90 MIL)
H11	YELLOW SINGLE CENTER, HRM (4", 90 MIL)
H12	10 FT. YELLOW SKIP, HRM (4", 90 MIL)
H13	YELLOW DOUBLE CENTER, HRM (4", 90 MIL)
H14	2 FT.-6FT./SP YELLOW MINISKIP, HRM (4", 90 MIL)
H40	WHITE GORELINE, HRM (8", 90 MIL)
H45	3 FT.-3FT./SP WHITE MINISKIP (8", 90 MIL)
T41	WHITE DIAGONAL (8", 90 MIL)
T42	YELLOW DIAGONAL (8", 90 MIL)
T61	WHITE STOPBAR (24", 90 MIL)
T62	WHITE CROSSWALK LINE (24", 90 MIL)
T70	LEFT TURN ARROW (90 MIL)
T71	RIGHT TURN ARROW (90 MIL)
T72	STRAIGHT ARROW (90 MIL)
T77	U-TURN ARROW (90 MIL)
T90	BICYCLE SYMBOL, HEATED-IN-PLACE (90 MIL)
T91	BICYCLE STRAIGHT ARROW, HEATED-IN-PLACE (90 MIL)
T100	ALPHANUMERIC CHAR. (90 MIL)
T103	24" YIELD LINE TRIANGLE (90 MIL)
T118	FISH-HOOK W/ CIRCLE LEFT/RIGHT/STRAIGHT ARROW (90 MIL)
	<u>PAVEMENT MARKERS</u>
ME	SNOWPLOWABLE MARKER (YELLOW/YELLOW)
MF	SNOWPLOWABLE MARKER (CRYSTAL/RED)

LEGEND

GENERAL

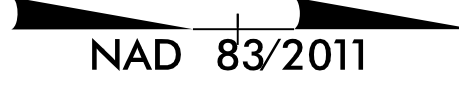
 NAD 83/2011 NORTH ARROW

 PROPOSED PAVEMENT

PAVEMENT MARKINGS

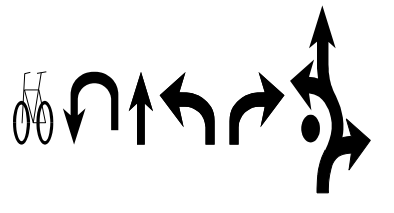
 PAVEMENT MARKING SYMBOLS

 SNOWPLOWABLE MARKER (CRYSTAL/RED)

 SNOWPLOWABLE MARKER (YELLOW/YELLOW)

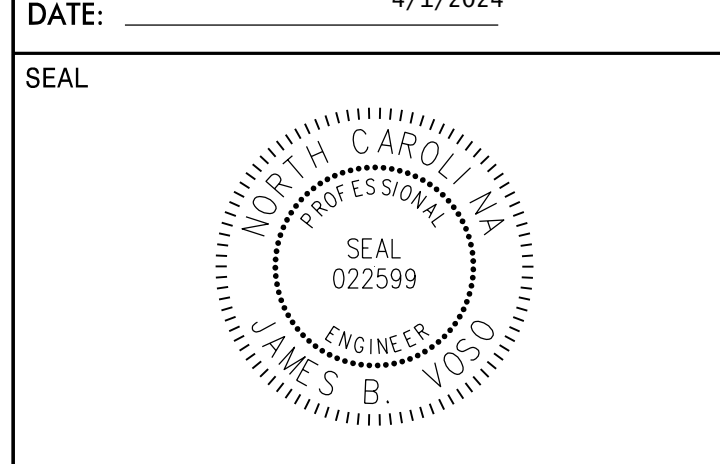

**DOCUMENT NOT CONSIDERED FINAL
UNLESS ALL SIGNATURES COMPLETED**

Mattern & Craig
 ENGINEERS • SURVEYORS
 FIRM LICENSE No. C-1154
 12 BROAD STREET
 ASHEVILLE, NORTH CAROLINA 28801
 (828) 254-2201
 FAX (828) 254-4562

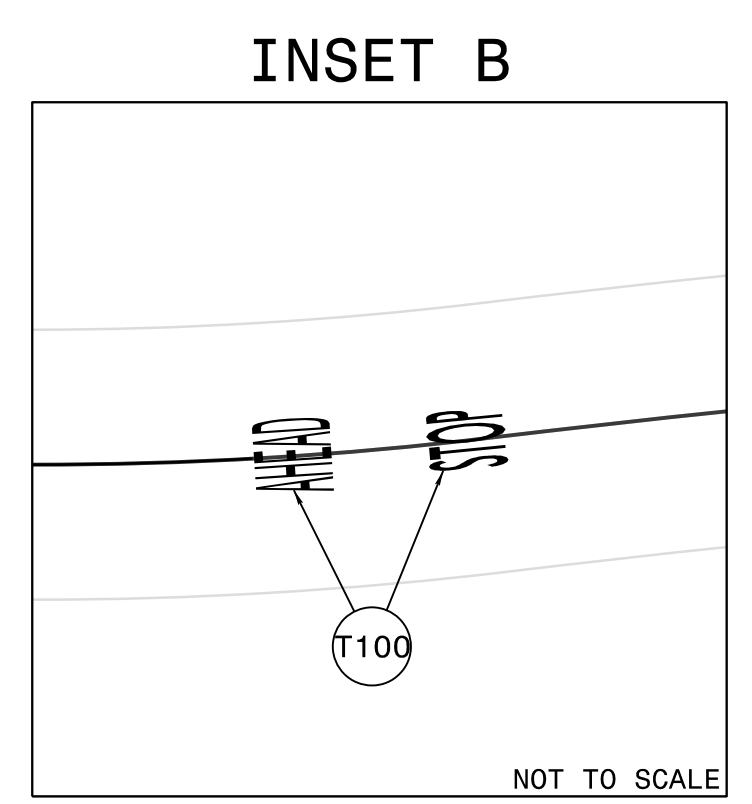
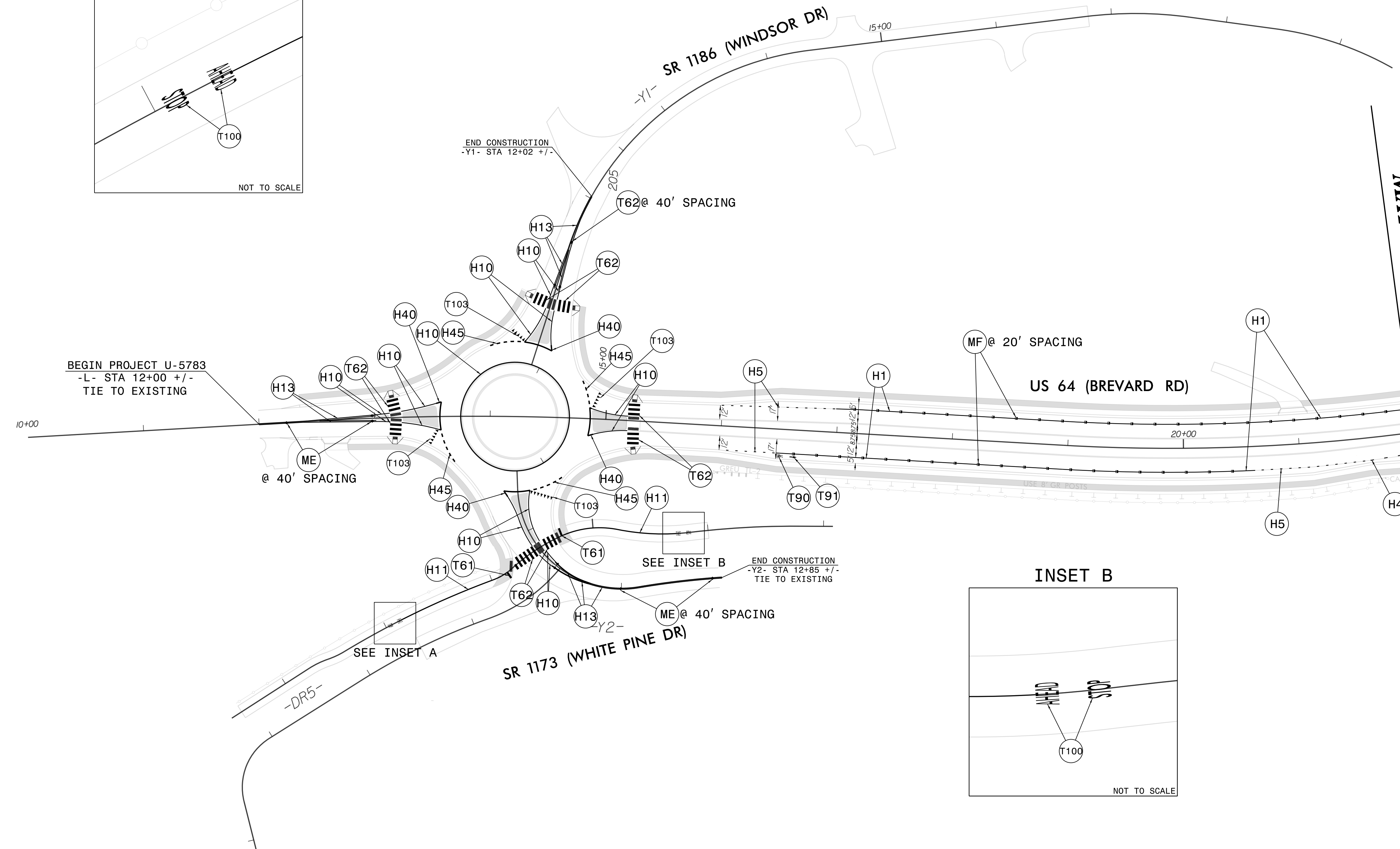
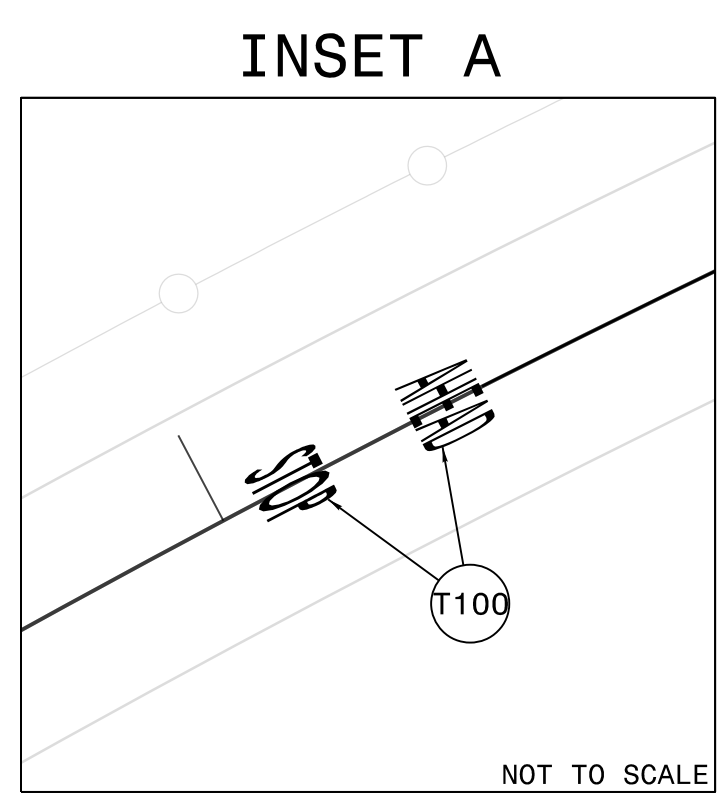
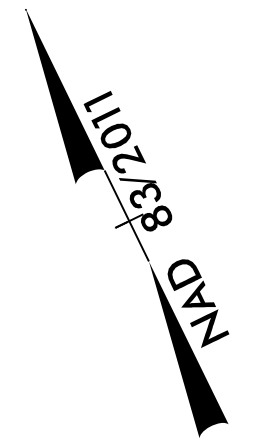

MATCHLINE -L- STA. 22+00 SEE SHEET 2B

REVISIONS

PROJECT NOTES
 SEE SHEET PMP-1A FOR PAVEMENT MARKING SCHEDULE

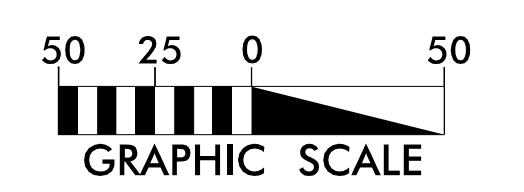

4" CONC. SIDEWALK

PAVEMENT MARKING DETAIL

APPROVED: *James Voso*
148FD60376E041F
 DATE: 4/1/2024

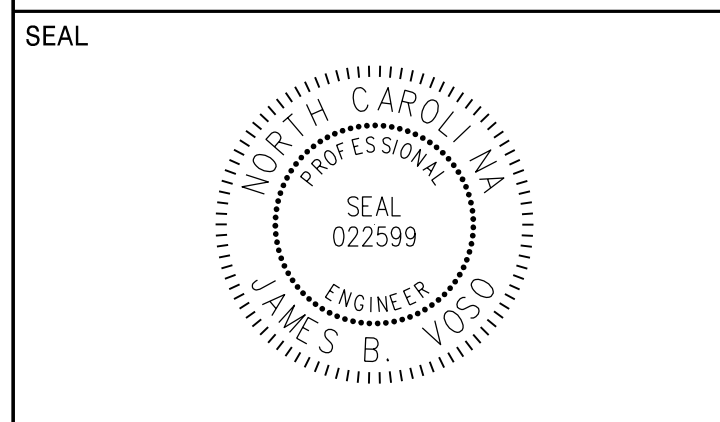

**DOCUMENT NOT CONSIDERED FINAL
 UNLESS ALL SIGNATURES COMPLETED**

Mattern & Craig
 ENGINEERS • SURVEYORS
 FIRM LICENSE No. C-1154
 12 BROAD STREET
 ASHEVILLE, NORTH CAROLINA 28801
 (828) 254-2201
 FAX (828) 254-4562

NUMBER	CURB RAMP	STATION	OFFSET
1	TYPE 3	-Y1- 11+04 +/-	18+/- LT
2	TYPE 7	-Y1- 11+03 +/-	2+/- LT
3	TYPE 7	-Y1- 11+03 +/-	2+/- RT
4	TYPE 3	-Y1- 11+05 +/-	20+/- RT
5	TYPE 3	-L- 13+15 +/-	18+/- LT
6	TYPE 7	-L- 13+18 +/-	3+/- LT
7	TYPE 7	-L- 13+19 +/-	2+/- RT
8	TYPE 3	-L- 13+17 +/-	18+/- RT
9	TYPE 3	-L- 15+24 +/-	17+/- LT
10	TYPE 7	-L- 15+24 +/-	2+/- LT
11	TYPE 7	-L- 15+24 +/-	7+/- RT
12	TYPE 3	-L- 15+25 +/-	24+/- RT
13	TYPE 1 MOD	-Y2- 11+17 +/-	29+/- RT
14	TYPE 7	-Y2- 11+18 +/-	2+/- RT
15	TYPE 7	-Y2- 11+18 +/-	2+/- LT
16	TYPE 1 MOD	-Y2- 11+21 +/-	19+/- LT

- 1 -L- STA 13+19 +/-
17 +/- LT
- 2 -L- STA 13+18 +/-
4 +/- LT
- 3 -L- STA 13+53 +/-
11 +/- LT
- 4 -L- STA 13+56 +/-
11 +/- RT
- 5 -Y1- STA 10+64 +/-
13 +/- LT
- 6 -Y1- STA 10+70 +/-
26 +/- LT
- 7 -Y1- STA 10+66 +/-
11 +/- LT
- 8 -Y1- STA 11+02 +/-
3 +/- LT
- 9 -Y1- STA 11+04 +/-
17 +/- LT
- 10 -Y1- STA 12+00 +/-
+/- T
- 11 -Y1- STA 11+03 +/-
4 +/- RT
- 12 -Y1- STA 11+05 +/-
18 +/- RT
- 13 -Y1- STA 10+68 +/-
11 +/- RT
- 14 -L- STA 14+88 +/-
10 +/- LT
- 15 -L- STA 14+93 +/-
26 +/- LT
- 16 -L- STA 15+19 +/-
- 17 -L- STA 13+01 +/-
- 18 -L- STA 13+17 +/-
- 19 -L- STA 13+48 +/-
24 +/- RT
- 20 -L- STA 13+55 +/-
12 +/- RT
- 21 -Y2- STA 10+69 +/-
9 +/- RT
- 22 -Y2- STA 10+66 +/-
10 +/- LT
- 23 -Y2- STA 11+17 +/-
4 +/- RT
- 24 -Y2- STA 11+17 +/-
27 +/- RT
- 25 -Y2- STA 11+36 +/-
- 26 -Y2- STA 10+75 +/-
30 +/- LT
- 27 -Y2- STA 10+64 +/-
11 +/- LT
- 28 -L- STA 14+87 +/-
9 +/- LT
- 29 -L- STA 14+90 +/-
13 +/- RT
- 30 -L- STA 15+24 +/-
- 31 -Y2- STA 11+21 +/-
17 +/- LT
- 32 -Y2- STA 11+18 +/-
4 +/- LT
- 33 -GREENWAY 1- STA 203+15 +/-
- 34 -GREENWAY 1- STA 204+15 +/-
- 35 -GREENWAY 1- STA 204+72 +/-
- 36 -GREENWAY 1- STA 205+72 +/-

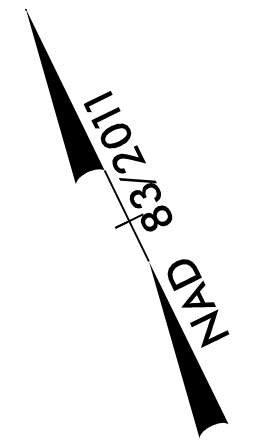
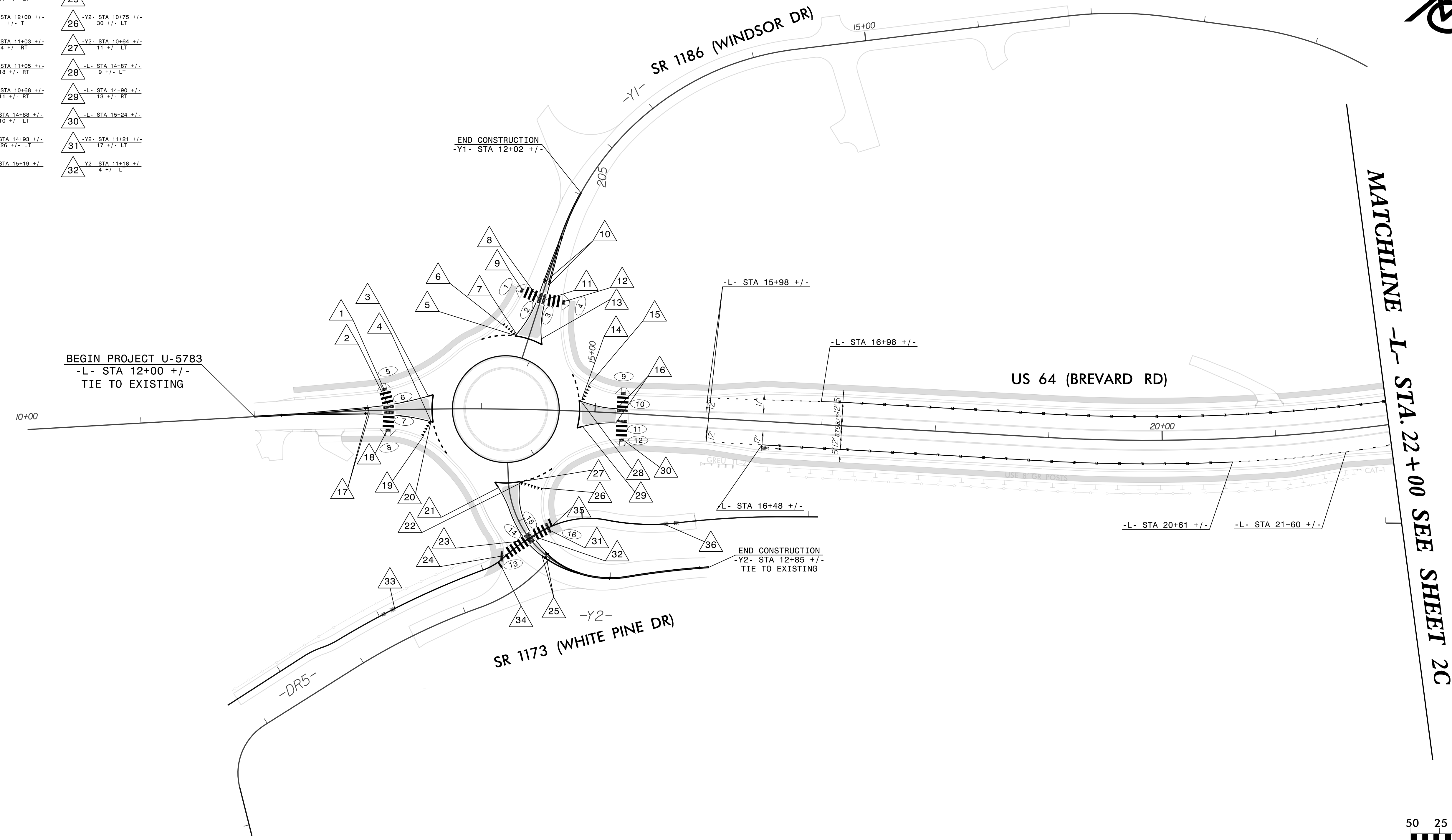

REVISIONS

-
-
-
-
-
-
-
-
-
-

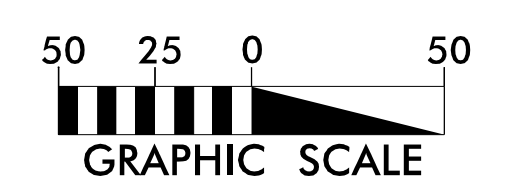

4" CONC. SIDEWALK

PAVEMENT MARKING DETAIL

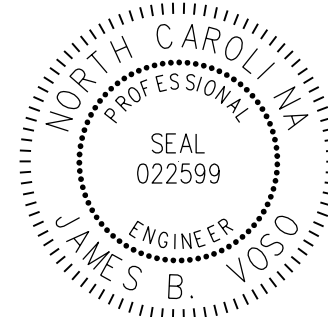
TIP NO. U-5783	SHEET NO. PMP-2D
APPROVED: <i>James Voso</i> <small>140FD00378E041F</small>	
DATE: 4/1/2024	
SEAL 	
DOCUMENT NOT CONSIDERED FINAL UNLESS ALL SIGNATURES COMPLETED	

Mattern & Craig
 ENGINEERS • SURVEYORS
 FIRM LICENSE No. C-1154
 12 BROAD STREET
 ASHEVILLE, NORTH CAROLINA 28801
 (828) 254-2201
 FAX (828) 254-4562

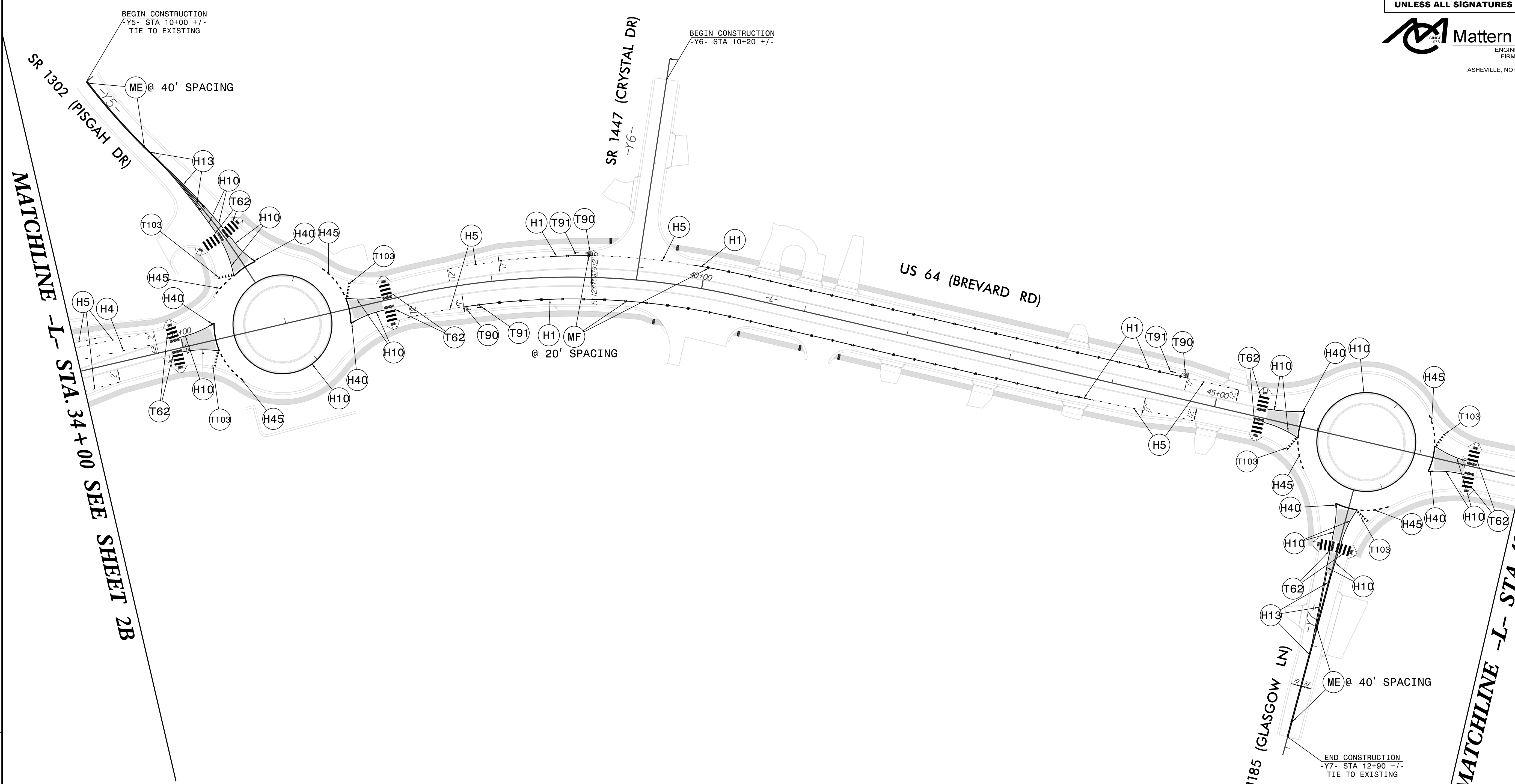

REVISIONS

PROJECT NOTES
 SEE SHEET PMP-1A FOR PAVEMENT MARKING SCHEDULE

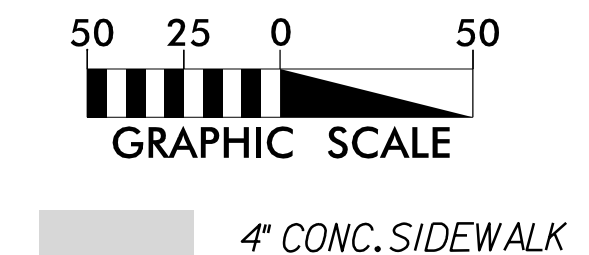

PAVEMENT MARKING DETAIL

NAD 83/2011



REVISIONS

1 -Y5- STA 11+95 +/- 5 +/- RT	16 -L- STA 34+98 +/-	31 -L- STA 47+45 +/-
2 -Y5- STA 11+94 +/- 23 +/- RT	17 -L- STA 34+26 +/-	32 -L- STA 45+44 +/-
3 -Y5- STA 12+28 +/- 27 +/- RT	18 -L- STA 34+34 +/-	33 -L- STA 45+77 +/- 12 +/- RT
4 -L- STA 35+29 +/- 14 +/- LT	19 -L- STA 34+76 +/-	34 -L- STA 45+83 +/- 12 +/- RT
5 -L- STA 35+31 +/- 10 +/- RT	20 -L- STA 34+93 +/-	35 -Y7- STA 10+68 +/- 8 +/- LT
6 -Y5- STA 12+33 +/- 15 +/- RT	21 -L- STA 35+28 +/- 25 +/- RT	36 -Y7- STA 10+68 +/- 8 +/- LT
7 -Y5- STA 11+85 +/-	22 -L- STA 35+32 +/- 12 +/- RT	37 -Y7- STA 11+05 +/-
8 -Y5- STA 11+85 +/- 5 +/- LT	23 -L- STA 36+65 +/- 13 +/- RT	38 -Y7- STA 11+04 +/- 7 +/- RT
9 -Y5- STA 11+94 +/- 17 +/- LT	24 -L- STA 36+63 +/- 10 +/- LT	39 -Y7- STA 11+29 +/-
10 -Y5- STA 12+32 +/- 13 +/- RT	25 -L- STA 45+49 +/-	40 -Y7- STA 11+04 +/- 1 +/- LT
11 -Y5- STA 12+29 +/- 9 +/- LT	26 -L- STA 45+82 +/- 10 +/- RT	41 -Y7- STA 11+05 +/-
12 -L- STA 36+61 +/- 12 +/- LT	27 -L- STA 45+80 +/- 14 +/- LT	42 -Y7- STA 10+72 +/- 21 +/- LT
13 -L- STA 36+67 +/- 25 +/- LT	28 -L- STA 47+12 +/- 12 +/- LT	43 -Y7- STA 10+65 +/- 9 +/- LT
14 -L- STA 36+84 +/-	29 -L- STA 47+18 +/- 25 +/- LT	44 -L- STA 47+16 +/- 13 +/- RT
15 -L- STA 34+70 +/-	30 -L- STA 47+50 +/-	45 -L- STA 47+14 +/- 10 +/- LT

NUMBER	CURB RAMP	STATION	OFFSET
1	TYPE 3	-Y5- 11+94 +/-	25 +/- RT
2	TYPE 7	-Y5- 11+95 +/-	3 +/- RT
3	TYPE 7	-Y5- 11+95 +/-	3 +/- LT
4	TYPE 3	-Y5- 11+94 +/-	18 +/- LT
5	TYPE 3	-L- 34+92 +/-	23 +/- LT
6	TYPE 7	-L- 34+94 +/-	8 +/- LT
7	TYPE 7	-L- 34+93 +/-	3 +/- RT
8	TYPE 3	-L- 34+93 +/-	18 +/- RT
9	TYPE 3	-L- 36+99 +/-	18 +/- LT
10	TYPE 7	-L- 37+00 +/-	2 +/- LT
11	TYPE 7	-L- 36+99 +/-	6 +/- RT
12	TYPE 3	-L- 36+99 +/-	24 +/- RT
13	TYPE 1 MOD	-L- 39+11 +/-	35 +/- LT
14	TYPE 1 MOD	-L- 39+72 +/-	35 +/- LT
15	TYPE 1 MOD	-L- 39+58 +/-	38 +/- RT
16	TYPE 1 MOD	-L- 40+44 +/-	35 +/- RT
17	TYPE 1 MOD	-L- 41+04 +/-	35 +/- RT
18	TYPE 1 MOD	-L- 41+42 +/-	35 +/- RT
19	TYPE 3	-L- 45+44 +/-	24 +/- LT
20	TYPE 7	-L- 45+44 +/-	7 +/- LT
21	TYPE 7	-L- 45+44 +/-	2 +/- RT
22	TYPE 3	-L- 45+44 +/-	18 +/- RT
23	TYPE 3	-L- 47+50 +/-	18 +/- LT
24	TYPE 7	-L- 47+50 +/-	2 +/- LT
25	TYPE 7	-L- 47+50 +/-	7 +/- RT
26	TYPE 3	-L- 47+50 +/-	24 +/- RT
27	TYPE 3	-Y7- 11+05 +/-	19 +/- RT
28	TYPE 7	-Y7- 11+04 +/-	5 +/- RT
29	TYPE 7	-Y7- 11+04 +/-	0 +/-
30	TYPE 3	-Y7- 11+05 +/-	13 +/- LT

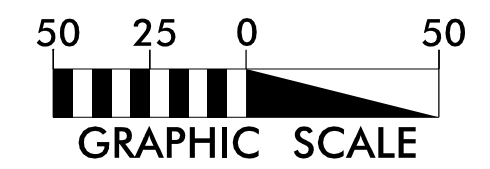

4" CONC. SIDEWALK

PAVEMENT MARKING DETAIL

MATCHLINE -L- STA. 34 + 00 SEE SHEET 2C

MATCHLINE -L- STA. 48 + 00 SEE SHEET 2G

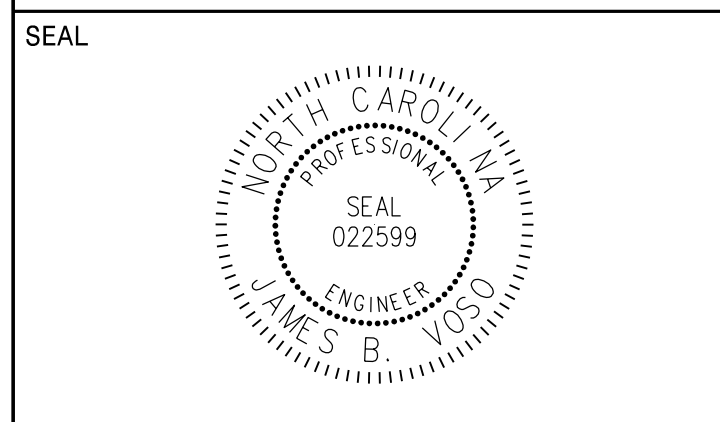

**DOCUMENT NOT CONSIDERED FINAL
 UNLESS ALL SIGNATURES COMPLETED**

Mattern & Craig
 ENGINEERS • SURVEYORS
 FIRM LICENSE No. C-1154
 12 BROAD STREET
 ASHEVILLE, NORTH CAROLINA 28801
 (828) 254-2201
 FAX (828) 254-4562

NUMBER	CURB RAMP	STATION	OFFSET
1	TYPE 1 MOD	-L- 52+66 +/-	35 +/- RT
2	TYPE 1 MOD	-L- 53+26 +/-	35 +/- RT
3	TYPE 1 MOD	-L- 56+70 +/-	35 +/- RT
4	TYPE 1 MOD	-L- 57+28 +/-	35 +/- RT
5	TYPE 1 MOD	-L- 57+58 +/-	35 +/- LT
6	TYPE 3 MOD	-L- 58+00 +/-	38 +/- LT

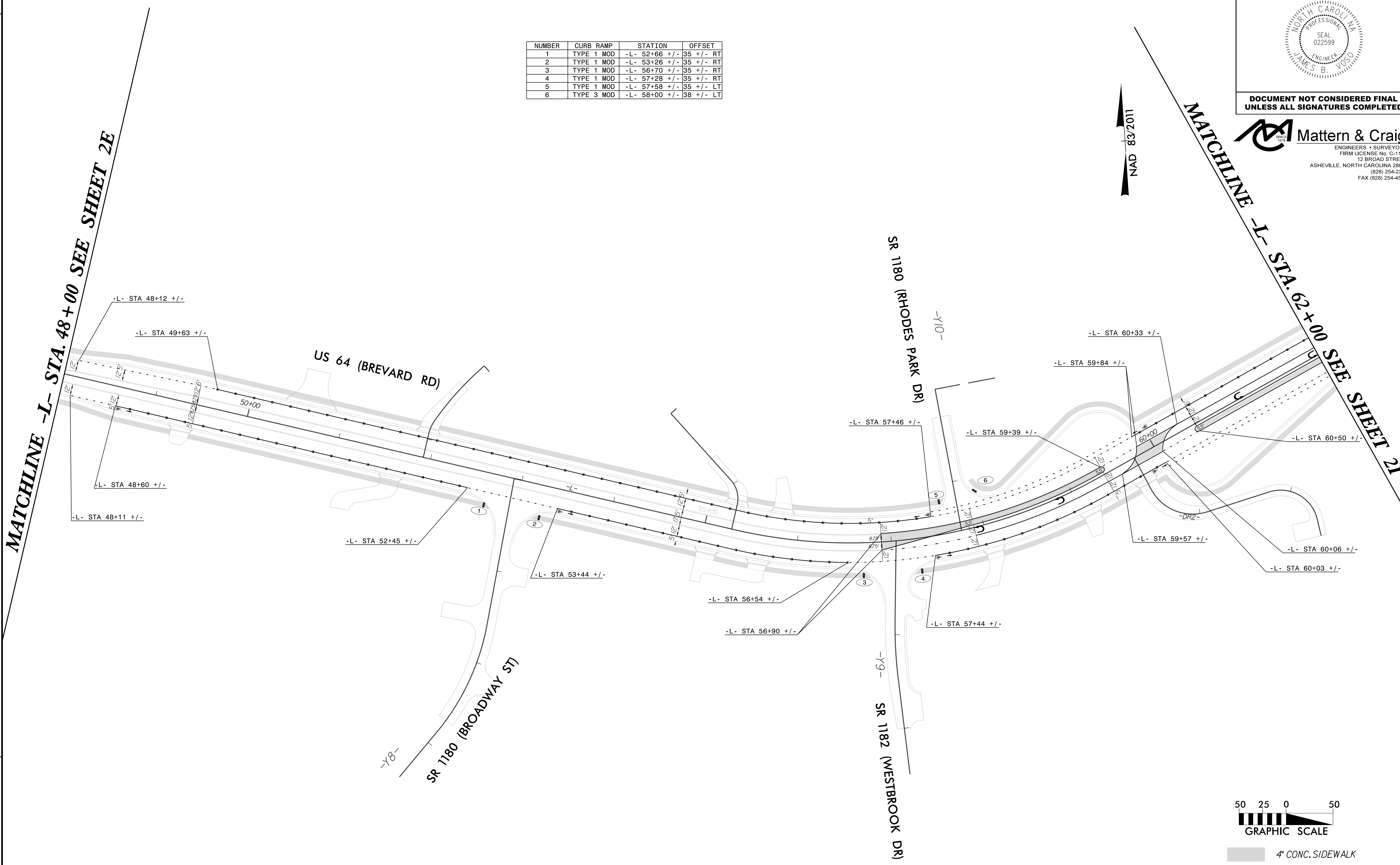
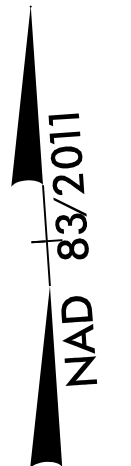

REVISIONS

- /-
- /-
- /-
- /-
- /-
- /-
- /-
- /-

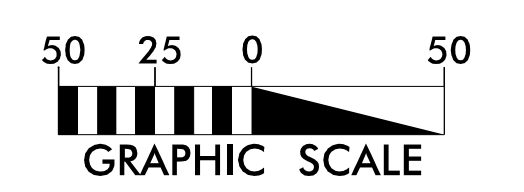

4" CONC. SIDEWALK

PAVEMENT MARKING DETAIL

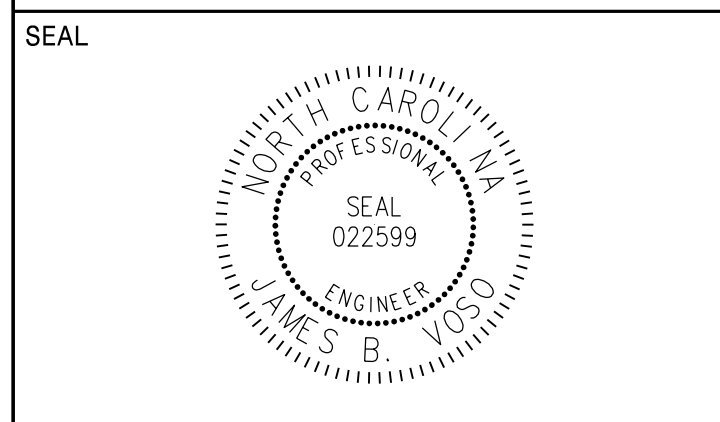

**DOCUMENT NOT CONSIDERED FINAL
UNLESS ALL SIGNATURES COMPLETED**

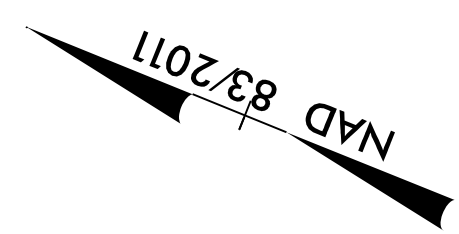
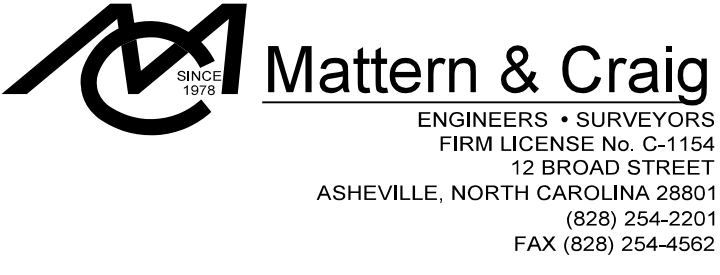

MATCHLINE -Y13- STA. 12+20 SEE SHEET 2H

SR 2162 (BLYTHE ST)

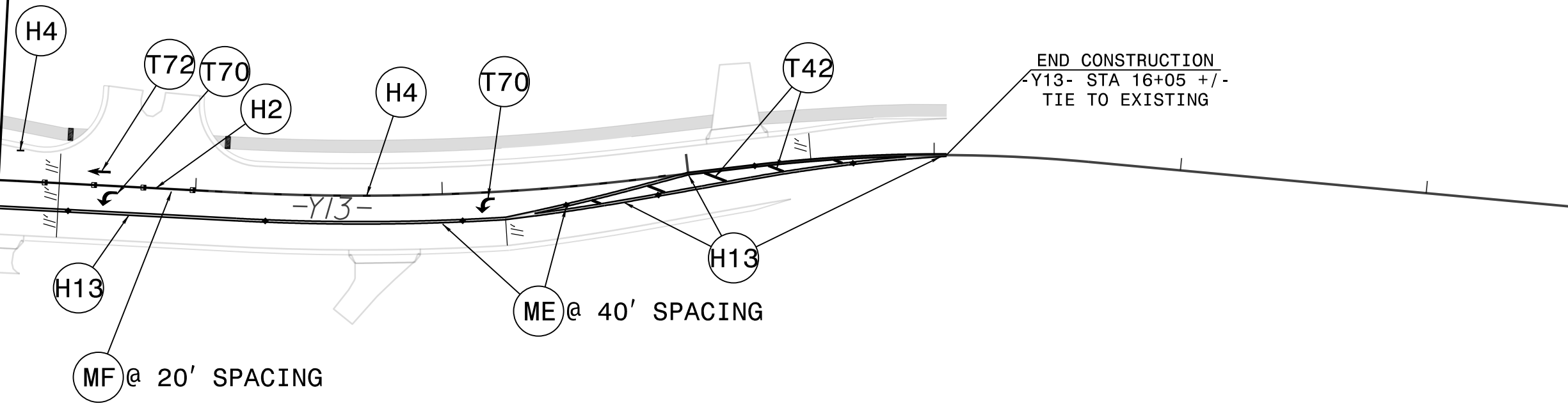

10

REVISIONS

PROJECT NOTES

SEE SHEET PMP-1A FOR PAVEMENT MARKING SCHEDULE

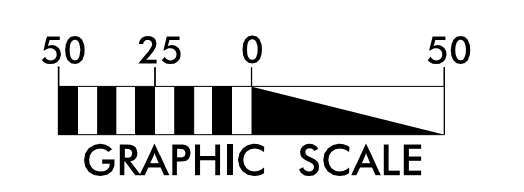

4" CONC. SIDEWALK

PAVEMENT MARKING DETAIL

APPROVED: *James Voso*
140FD60379E041F...
 DATE: 4/1/2024

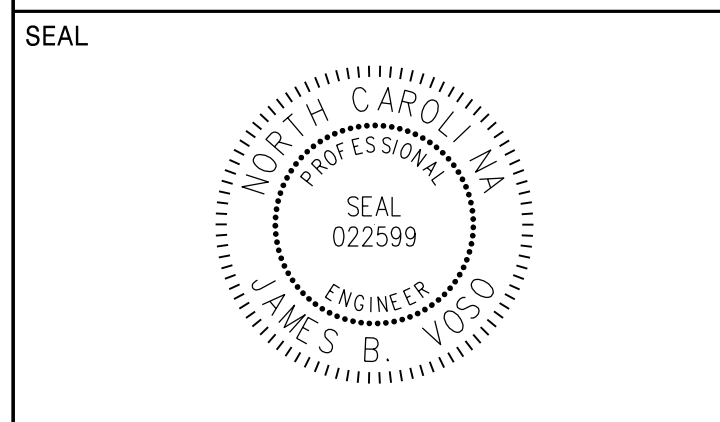

**DOCUMENT NOT CONSIDERED FINAL
UNLESS ALL SIGNATURES COMPLETED**

Mattern & Craig
 ENGINEERS • SURVEYORS
 FIRM LICENSE No. C-1154
 12 BROAD STREET
 ASHEVILLE, NORTH CAROLINA 28801
 (828) 254-2201
 FAX (828) 254-4562

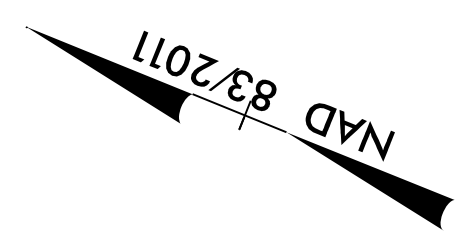

MATCHLINE -Y13- STA. 12+20 SEE SHEET 2I

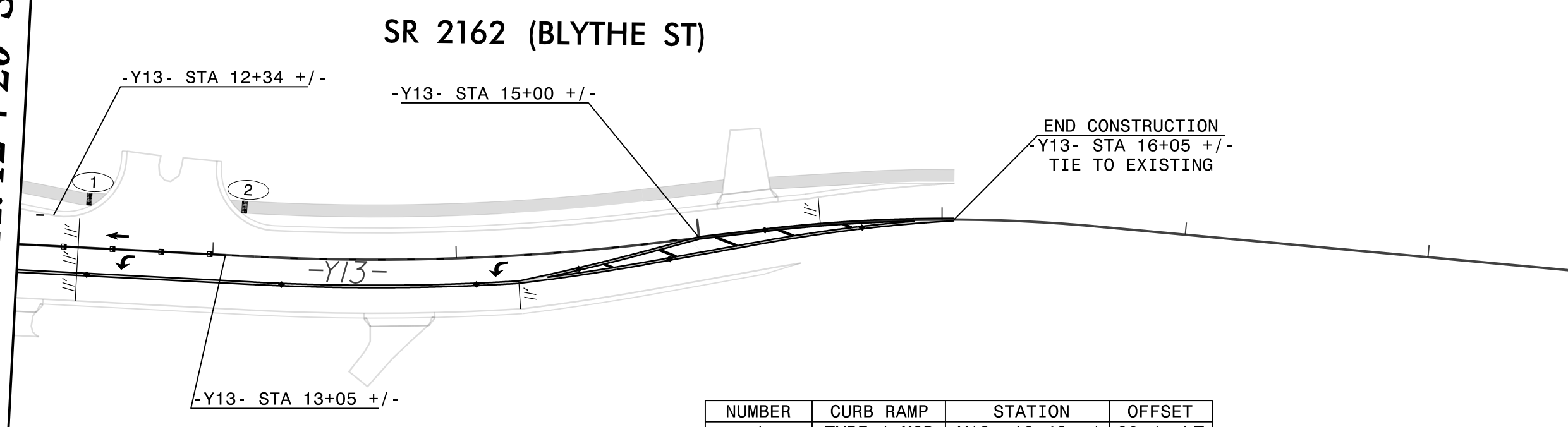

NUMBER	CURB RAMP	STATION	OFFSET
1	TYPE 1 MOD	-Y13- 12+48 +/-	20+/- LT
2	TYPE 1 MOD	-Y13- 13+12 +/-	20+/- LT

10

REVISIONS

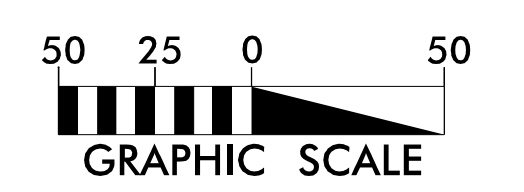

4" CONC. SIDEWALK

PAVEMENT MARKING DETAIL