

PROJECT I.D. NO.	SHEET NO.
U-5783	Sig.M6

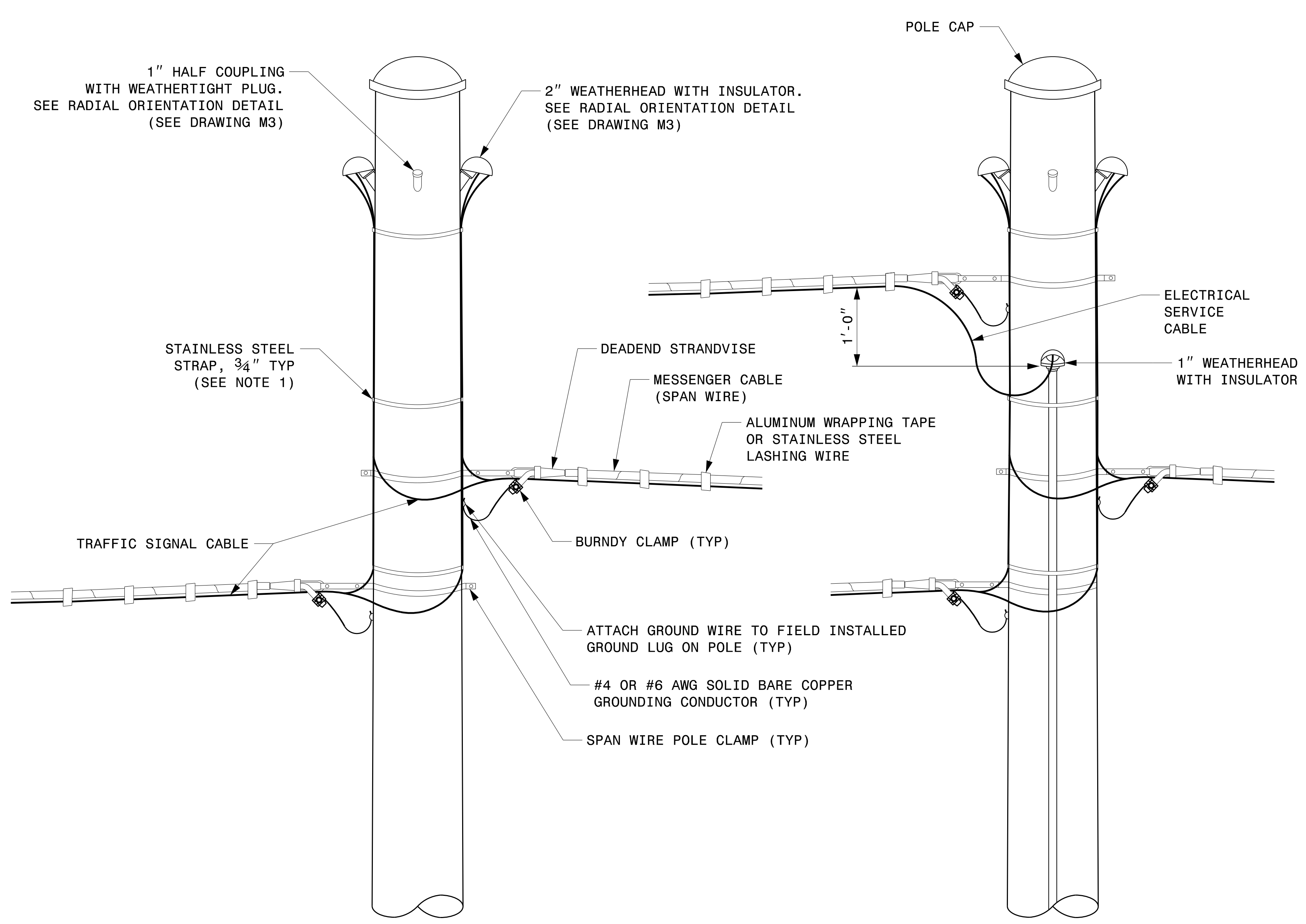

STRAIN POLE ATTACHMENTS

- NOTES:
1. STRAP ALL SIGNAL CABLES TO THE SIDE OF THE POLE WITH 3/4" STAINLESS STEEL STRAPS WHEN THE DISTANCE BETWEEN SPAN WIRE ATTACHMENT CLAMP AND WEATHERHEADS EXCEEDS 3'-0".
 2. PROVIDE MINIMUM TWO SPAN WIRE POLE CLAMPS PER POLE.
 3. IT IS PROHIBITED TO ATTACH TWO SPAN WIRES AT ONE POLE CLAMP.
 4. FOR GENERAL REQUIREMENTS, REFER TO NCDOT STANDARD SPECIFICATIONS FOR ROADWAY AND STRUCTURES, JANUARY 2024.

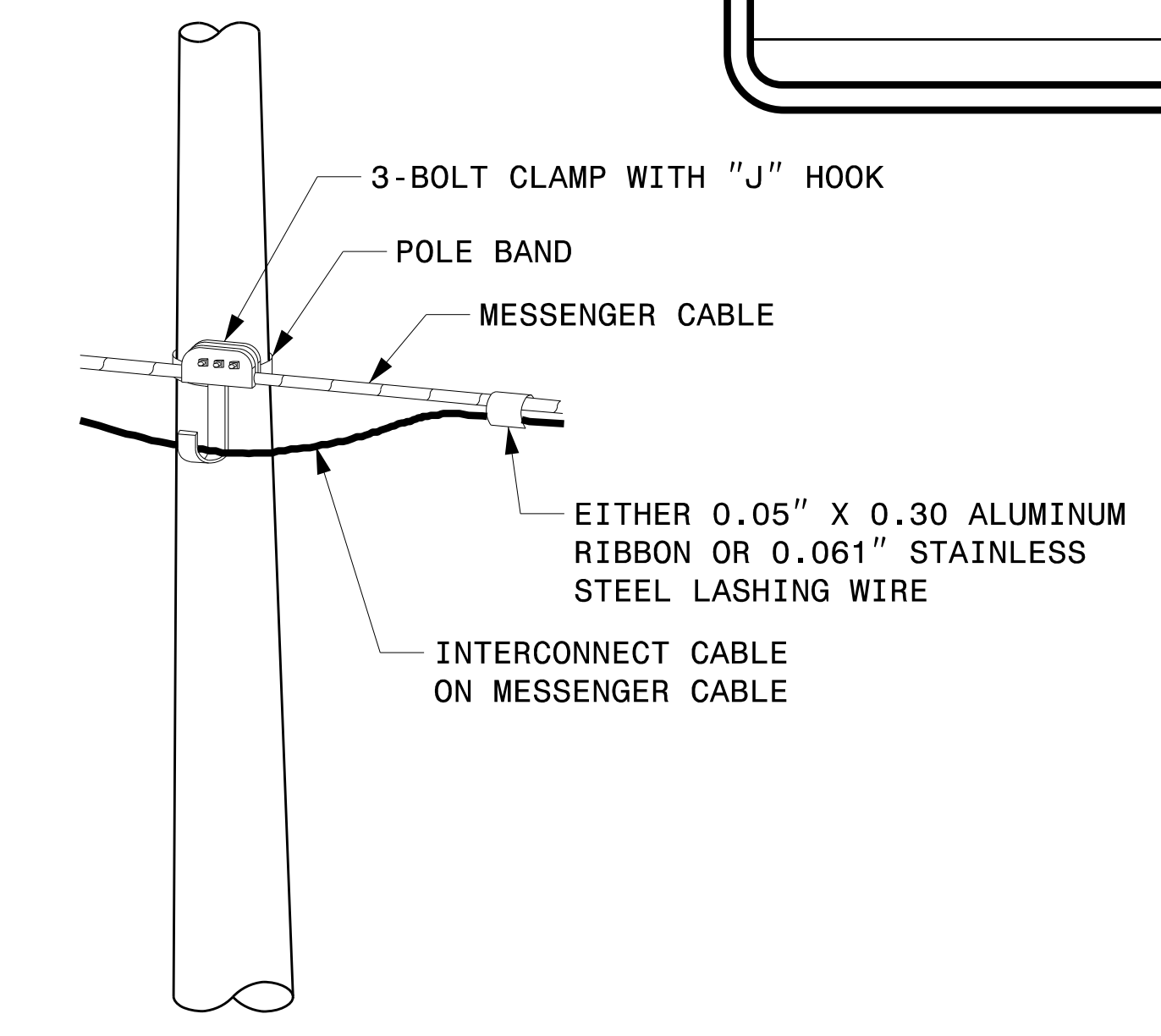

ATTACHMENT OF CABLE TO INTERMEDIATE METAL POLE

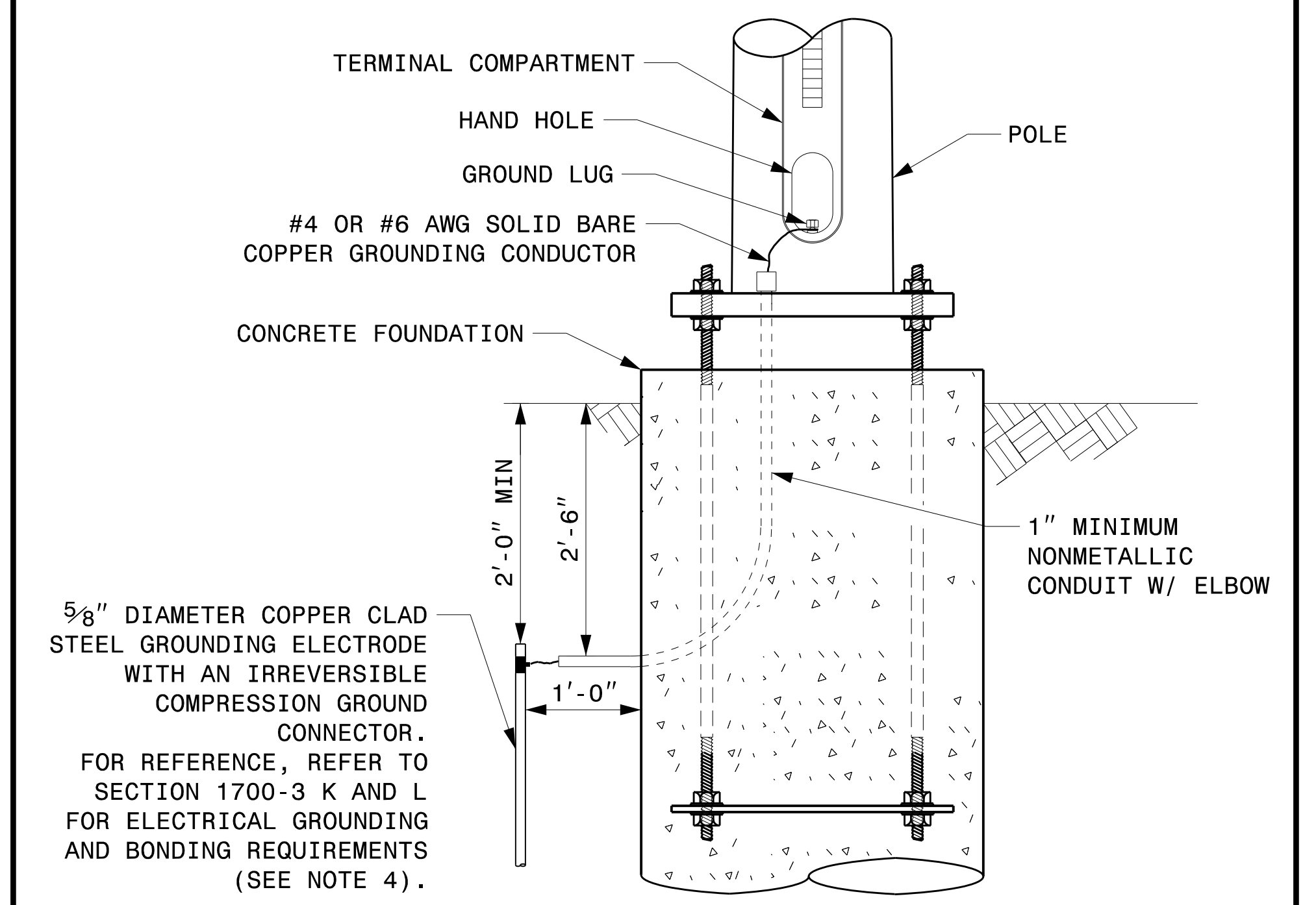

METAL POLE GROUNDING DETAIL FOR STRAIN POLE AND MAST ARM

Prepared In the Offices of:

750 N. Greenfield Pkwy, Garner, NC 27529

Typical Fabrication Details For Strain Pole Attachments

PLAN DATE:	SEPTEMBER 2023	DESIGNED BY:	C.F. ANDREWS
PREPARED BY:	K.C. DURIGON	REVIEWED BY:	D.C. SARKAR
REVISIONS	INIT.	DATE	

SEAL

DocuSigned by: **Kevin Durigon**

4823DC7983784DA...

99/21/2023 DATE

09-OCT-2023 12:41 S:\TSS\111\TSS-1\Signal\Structures\Drawings\2024_Metro_Pole_Sig\Drawings\2024_Sig.M6_Sig_M6_Sig_Fabrication_Details_Strain_Poles.dgn Kcdur100n

Fabrication Details – Strain Pole Attachments