

PROJECT REFERENCE NO. <i>U-5783</i>	SHEET NO. <i>EC-II/CONS.5</i>
RW SHEET NO.	
ROADWAY DESIGN ENGINEER	HYDRAULICS ENGINEER

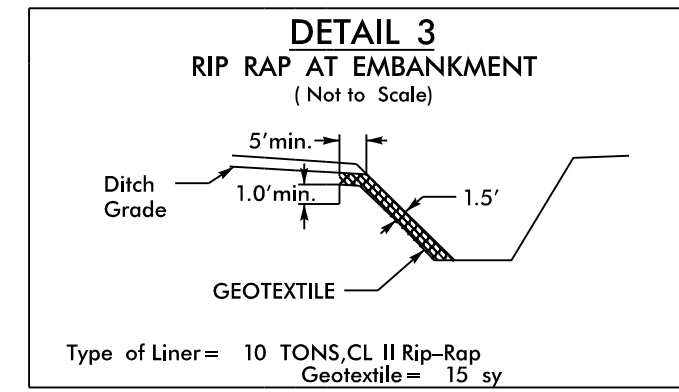
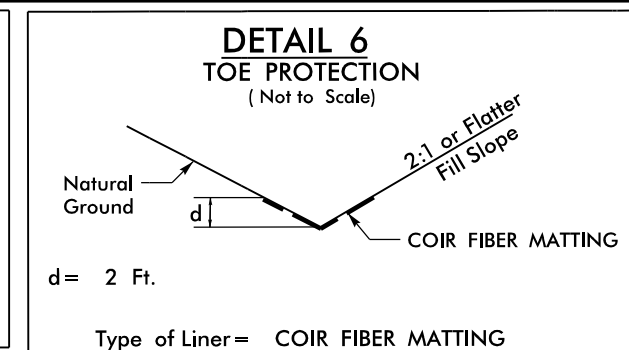
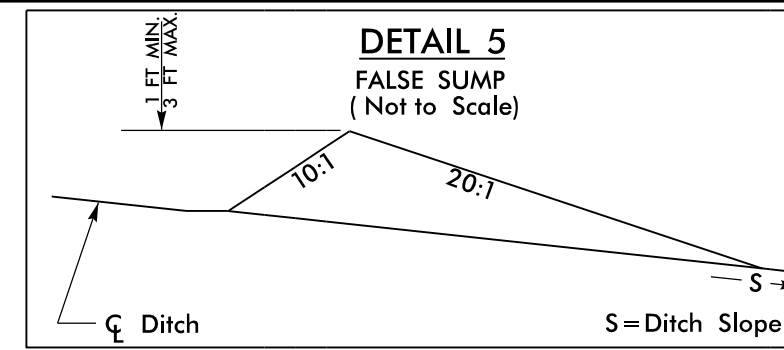

BEGIN WALL #2 & HANDRAIL (SEE SHEET 2C-1)
 -Y4- STA 11+49 LT TO -L- STA 34+78 LT
 -RW2- STA 10+00 TO -RW2- STA 13+26.01

NAD 83/2011

Mattern & Craig
 ENGINEERS + SURVEYORS
 FIRM LICENSE No. C-1154
 12 BROAD STREET
 ASHEVILLE, NORTH CAROLINA 28801
 (828) 254-2201
 FAX (828) 254-4562

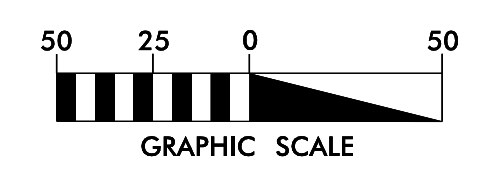
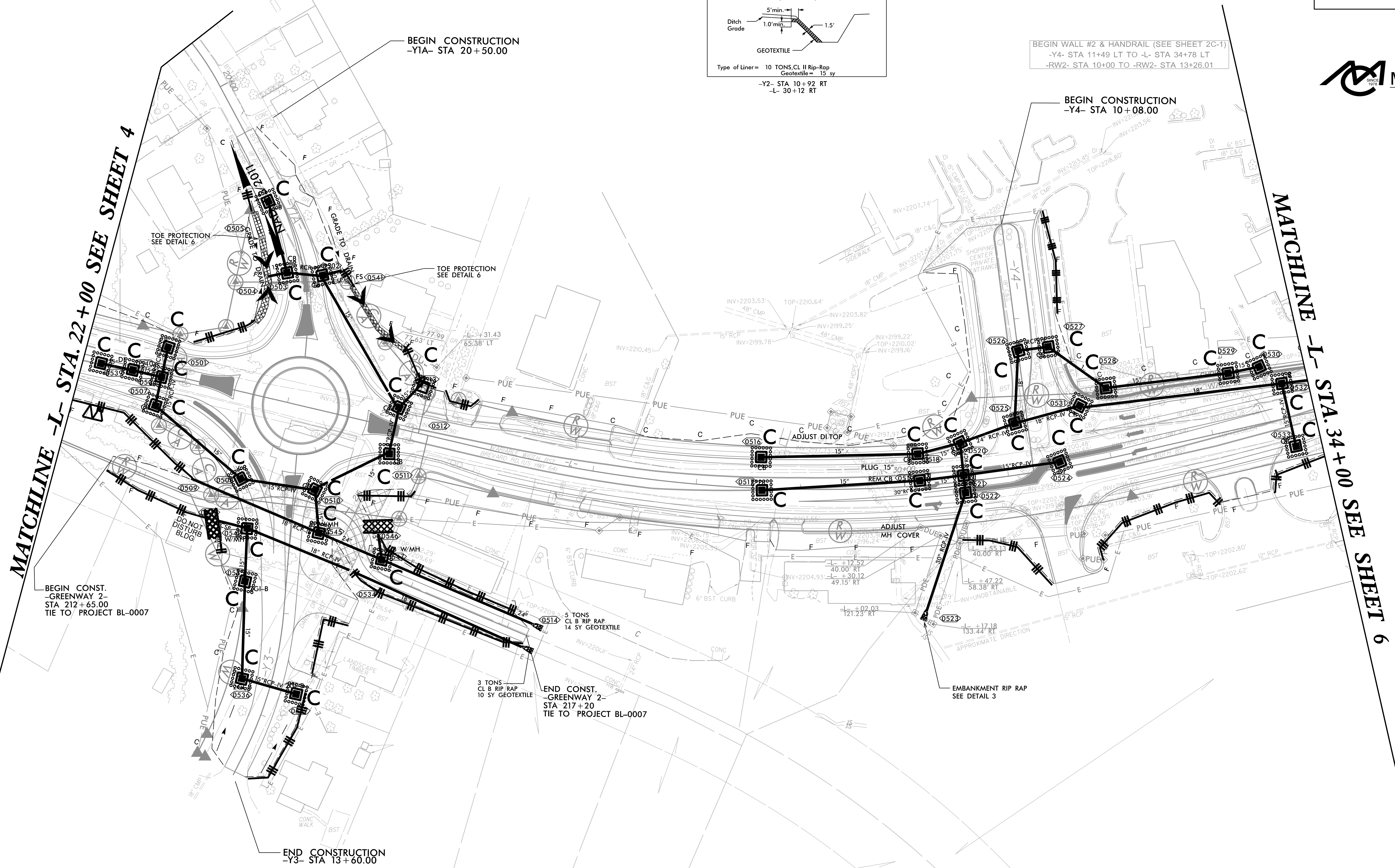

SEE SHEETS 11, 15, & 16 FOR PROFILES