

PROJECT REFERENCE NO. <i>U-5783</i>	SHEET NO. <i>EC-10/CONS.4</i>
RW SHEET NO.	
ROADWAY DESIGN ENGINEER	HYDRAULICS ENGINEER

Mattern & Craig
 ENGINEERS • SURVEYORS
 FIRM LICENSE No. C-1154
 12 BROAD STREET
 ASHEVILLE, NORTH CAROLINA 28801
 (828) 254-2201
 FAX (828) 254-4562

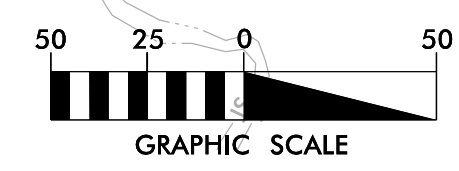
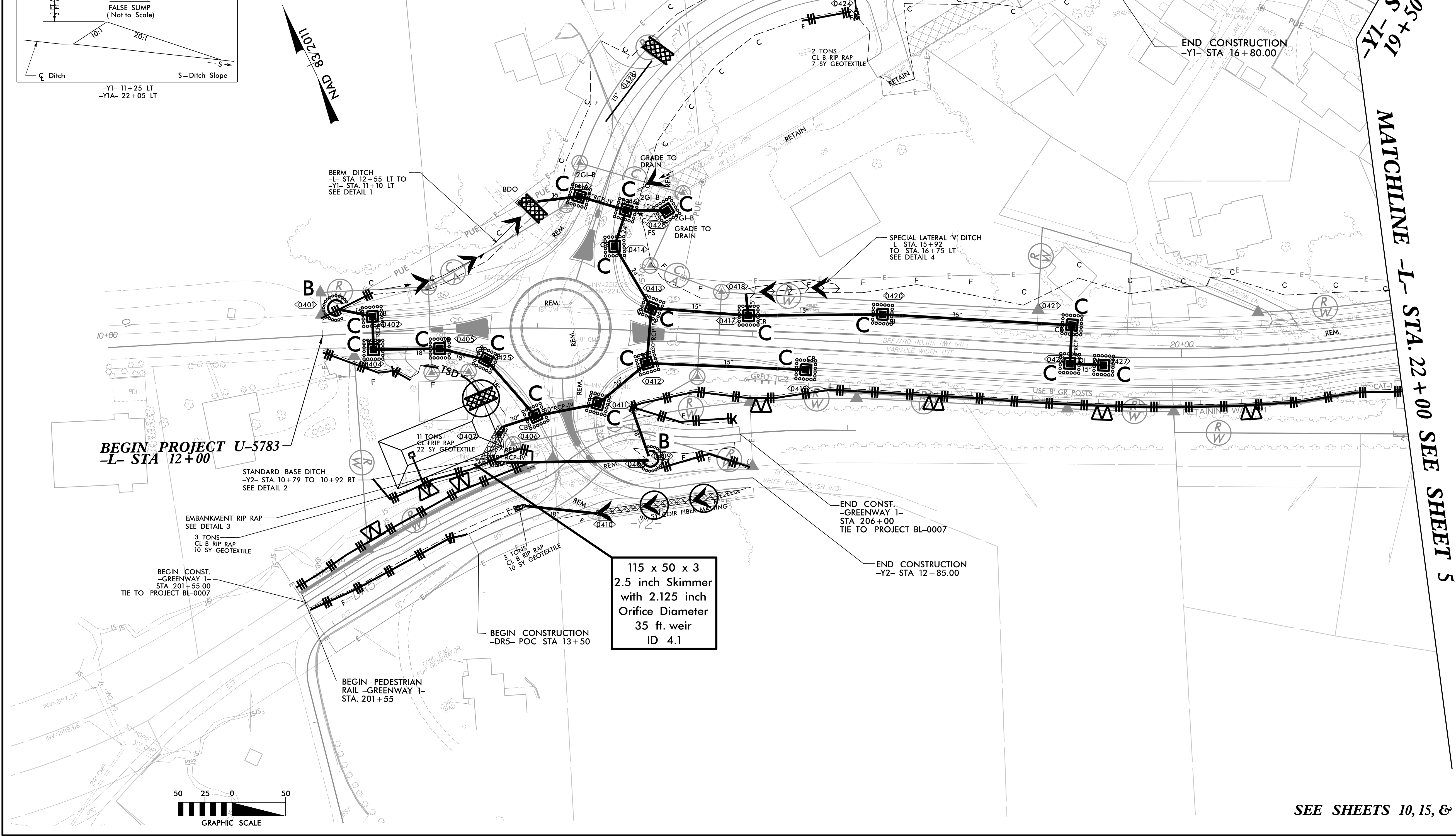
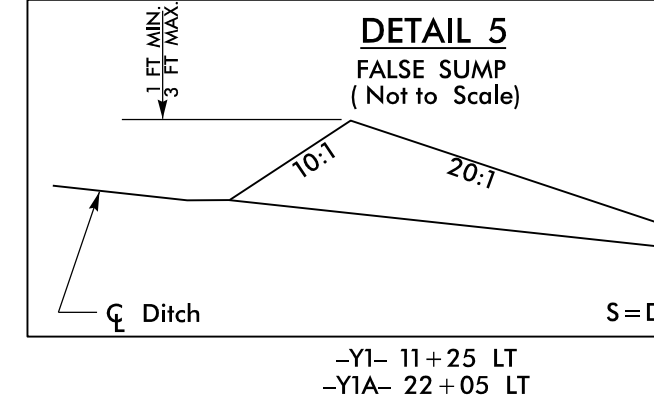
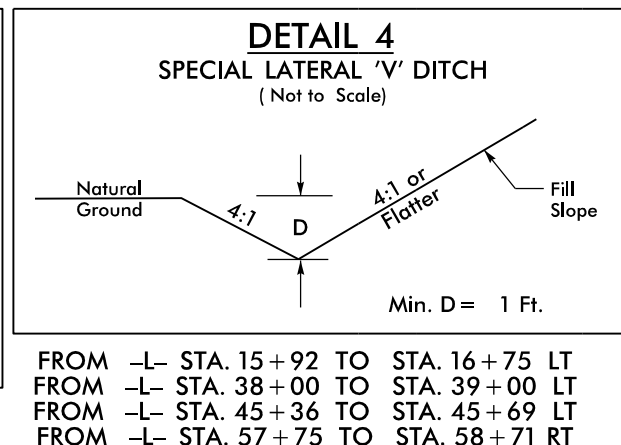
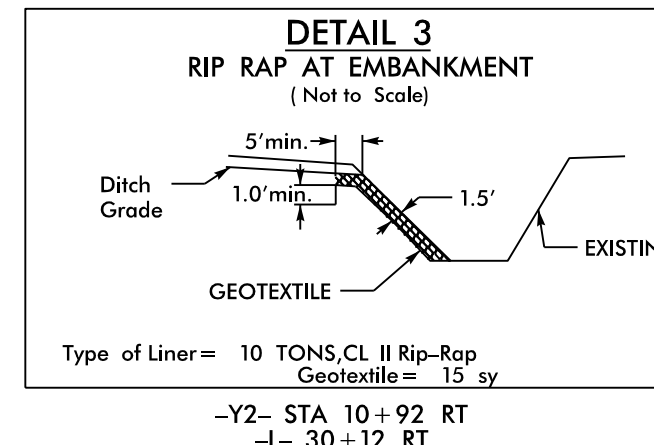
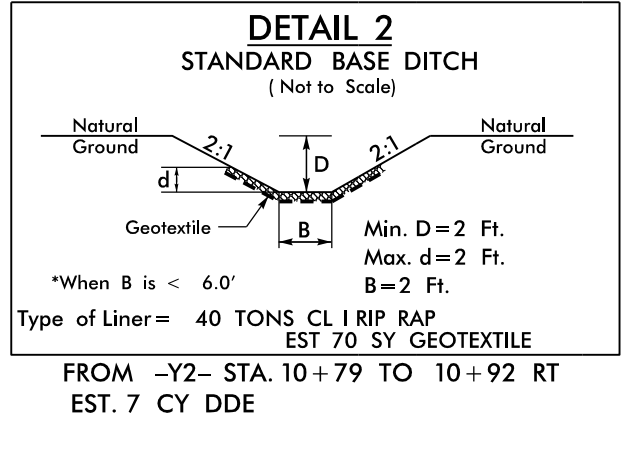
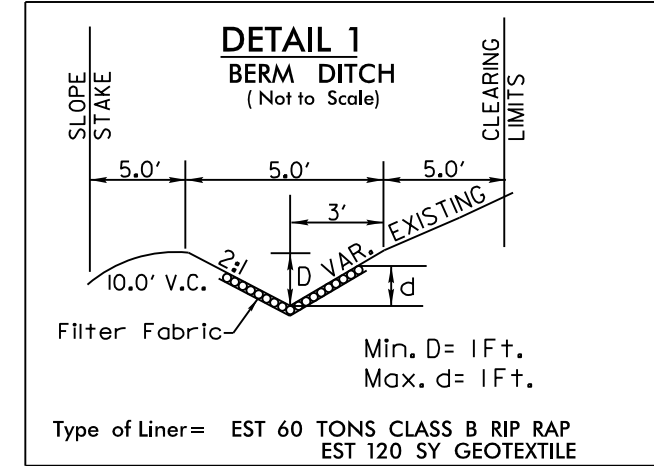

SEE SHEETS 10, 15, & 16 FOR PROFILES