

**STANDARD (ELECTRICAL)
JUNCTION BOX**

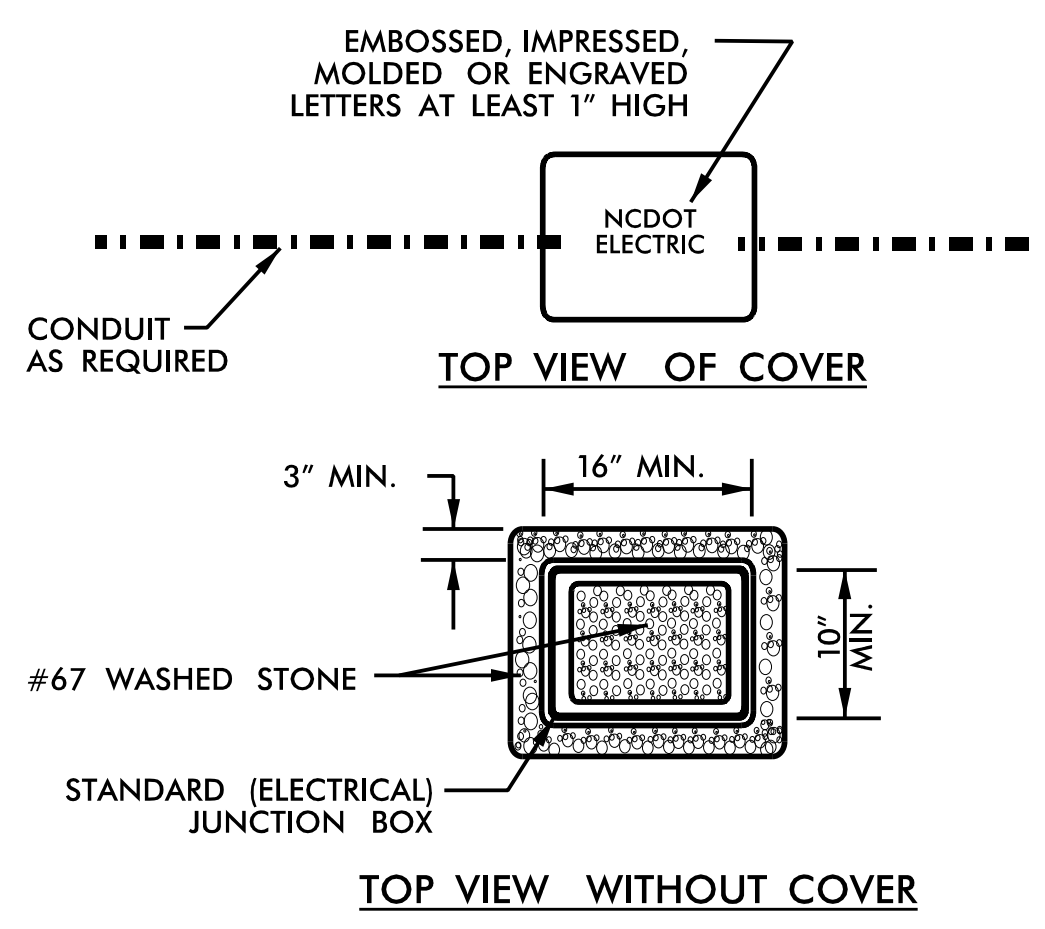

**OVERSIZED HEAVY DUTY
JUNCTION BOX**

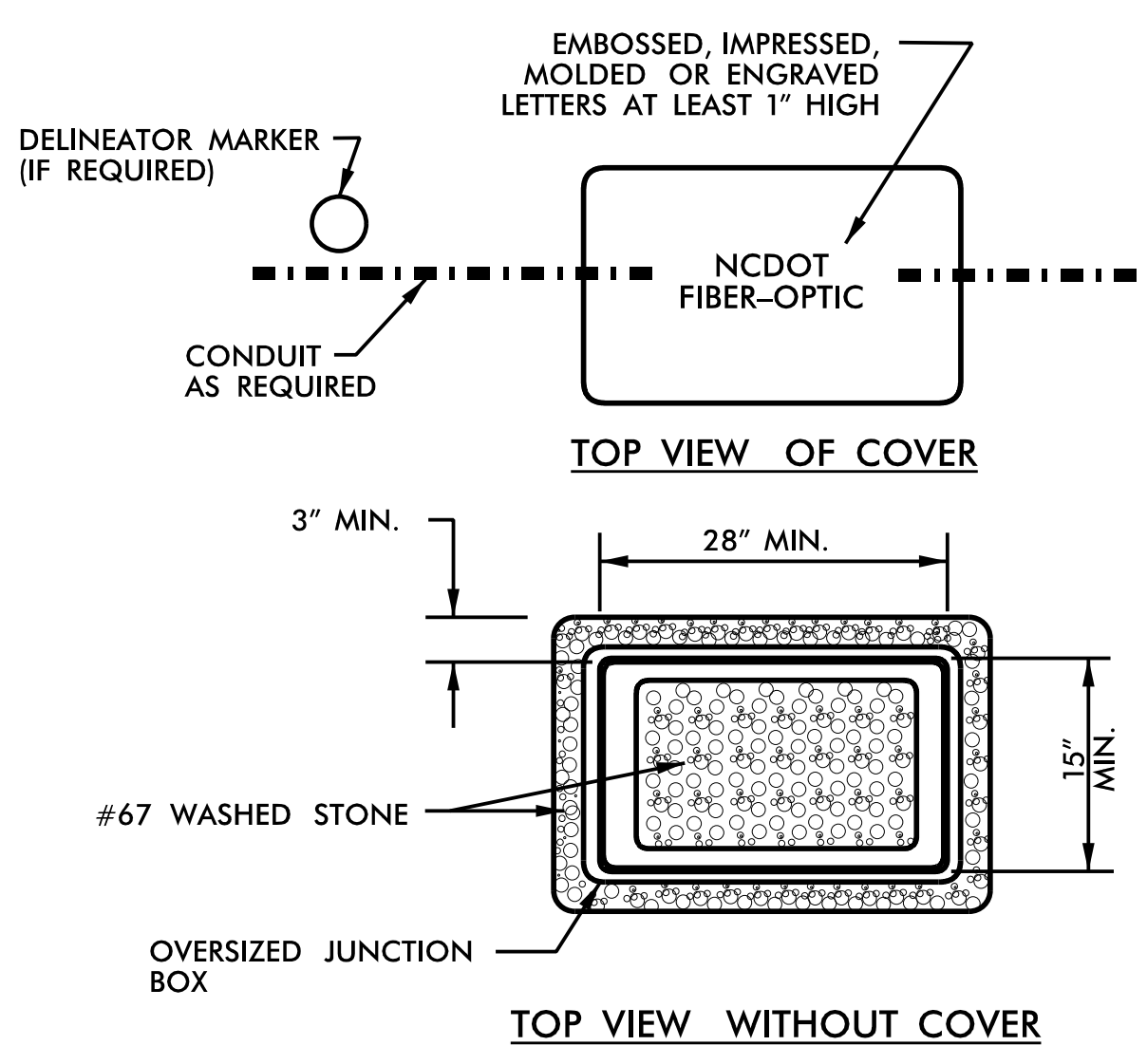

**SPECIAL OVERSIZED HEAVY DUTY
JUNCTION BOX**

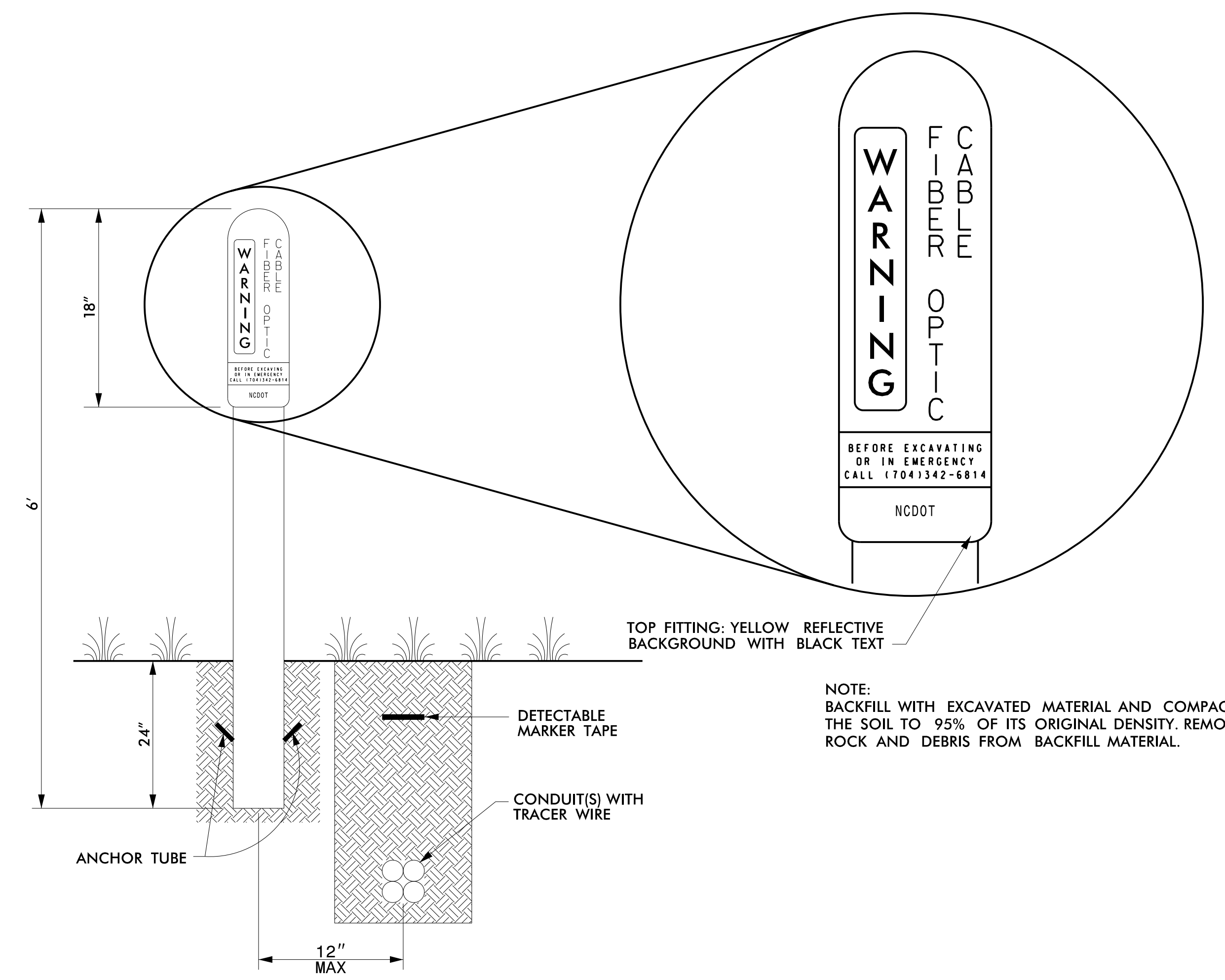
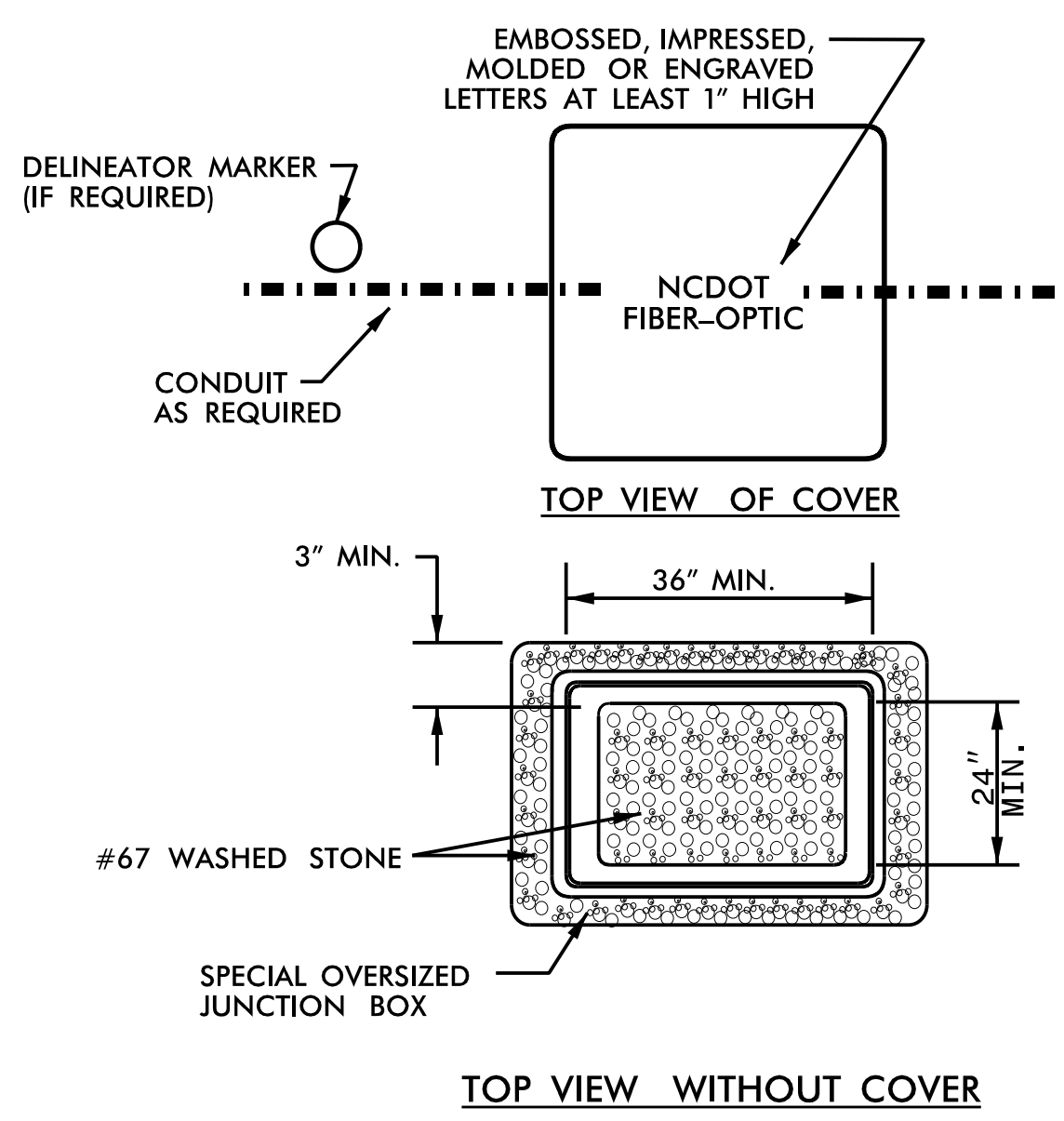

PVC POST-MOUNTED DELINEATOR MARKER

**DOCUMENT NOT CONSIDERED FINAL
UNLESS ALL SIGNATURES COMPLETED**

HNTB
HNTB NORTH CAROLINA, P.C.
343 E. Six Forks Road, Suite 200
Raleigh, North Carolina 27609
NC License No: C-1554
(919) 546-8997

	TYPICAL DETAILS		
	Division 8 Randolph County Asheboro PLAN DATE: Sept 2021 REVIEWED BY: J.A. Wagner PREPARED BY: T.R. Terrell REVIEWED BY: N.R. Simmons	SCALE: NONE REVISIONS: _____ INIT. DATE	
DocuSigned by: <i>Natasha R. Simmons</i> 5/21/2024 SIGNATURE DATE CADD Filename: u5813_SCP-14.dgn			